



U. S. Department  
of Transportation  
**Systems**  
Federal Railroad  
Administration

# Safety of High Speed Guided Ground Transportation

Office of Research  
and Development  
Washington, D.C. 20590

## Collision Avoidance and Accident Survivability Volume 1: Collision Threat

Arthur D. Little, Inc.  
Acorn Park  
Cambridge, MA

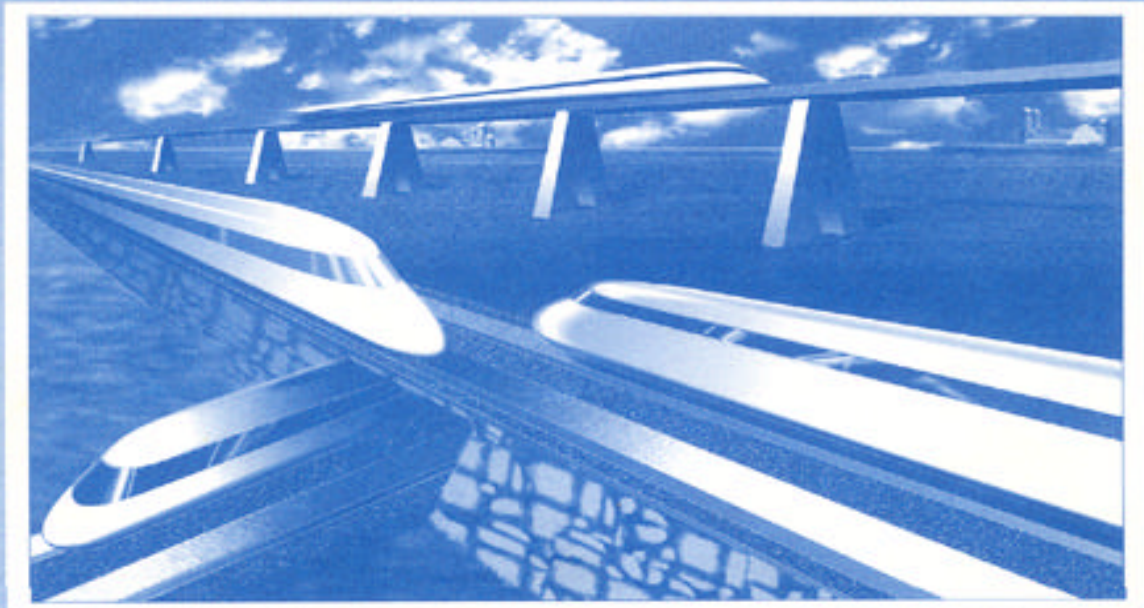

DOT/FRA/ORD-93/02.1  
DOT-VNTSC-FRA-93-2.1

Final Report  
March 1993

This document is available to the  
public through the National Technical  
Information Service, Springfield, VA 22161

### NOTICE

This document is disseminated under the sponsorship of the Department of Transportation in the interest of information exchange. The United States Government assumes no liability for its contents or use thereof.

### NOTICE

The United States Government does not endorse products or manufacturers. Trade or manufacturers' names appear herein solely because they are considered essential to the object of this report.

**REPORT DOCUMENTATION PAGE***Form Approved*  
*OMB No. 0704-0188*

Public reporting burden for this collection of information is estimated to average 1 hour per response, including the time for reviewing instructions, searching existing data sources, gathering and maintaining the data needed, and completing and reviewing the collection of information. Send comments regarding this burden estimate or any other aspect of this collection of information, including suggestions for reducing this burden, to Washington Headquarters Services, Directorate for Information Operations and Reports, 1215 Jefferson Davis Highway, Suite 1204, Arlington, VA 22202-4302, and to the Office of Management and Budget, Paperwork Reduction Project (0704-0188), Washington, DC 20503.

1. AGENCY USE ONLY (Leave blank)		2. REPORT DATE March 1993		3. REPORT TYPE AND DATES COVERED Final Report May 1991 – October 1992	
4. TITLE AND SUBTITLE Collision Avoidance and Accident Survivability Volume 1: Collision Threat				5. FUNDING NUMBERS  RR393/R3015	
6. AUTHOR(S) Alan J. Bing					
7. PERFORMING ORGANIZATION NAME(S) AND ADDRESS(ES) Arthur D. Little, Inc. Acorn Park Cambridge, MA 02140-2390				8. PERFORMING ORGANIZATION REPORT NUMBER  DOT-VNTSC-FRA-93-2.I	
9. SPONSORING/MONITORING AGENCY NAME(S) AND ADDRESS(ES) U.S. Department of Transportation Research and Special Programs Administration Volpe National Transportation Systems Center Kendall Square, Cambridge, MA 02142-1093				10. SPONSORING/MONITORING AGENCY REPORT NUMBER  DOT/FRA/ORD-93/02.I	
11. SUPPLEMENTARY NOTES  This research is sponsored by the Federal Railroad Administration, Office of Research and Development, Washington, DC 20590					
12a. DISTRIBUTION/AVAILABILITY STATEMENT  This document is available to the public through the National Technical Information Service, Springfield, VA 22161				12b. DISTRIBUTION CODE	
13. ABSTRACT (Maximum 200 words)  This report is the first of four volumes concerned with developing safety guidelines and specifications for high-speed guided ground transportation (HSGGT) collision avoidance and accident survivability. The overall approach taken in this study is to first formulate collision scenarios to which an HSGGT system may be exposed. Then existing U.S. and foreign rules, regulations, standards, and practices concerned with either preventing the occurrence of a collision, or mitigating the consequences of a collision are reviewed, together with pertinent practices from other forms of transportation, leading to the formulation of guidelines and specifications for collision avoidance and accident survivability.  This volume provides a discussion of collision scenarios to which an HSGGT system may be exposed, a description of regulations, standards and practices used by foreign railroad and HSGGT systems to protect against the incidence of and consequences of collisions and other accidents, and guidelines for collision avoidance and accident survivability. The guidelines include a discussion of system safety concepts as applied to HSGGT systems, the development of quantitative safety performance criteria, and a review of collision avoidance and accident survivability which may be used to protect against the collision scenarios.					
14. SUBJECT TERMS Transportation, safety, crashworthiness, human injury criteria, maglev, high-speed rail, high-speed guided ground transportation, structural analysis, structural testing				15. NUMBER OF PAGES 150	
				16. PRICE CODE	
17. SECURITY CLASSIFICATION OF REPORT Unclassified	18. SECURITY CLASSIFICATION OF THIS PAGE Unclassified	19. SECURITY CLASSIFICATION OF ABSTRACT Unclassified	20. LIMITATION OF ABSTRACT		

# METRIC/ENGLISH CONVERSION FACTORS

## ENGLISH TO METRIC

## METRIC TO ENGLISH

<p><b>LENGTH (APPROXIMATE)</b></p> <p>1 inch (in) = 2.5 centimeters (cm)</p> <p>1 foot (ft) = 30 centimeters (cm)</p> <p>1 yard (yd) = 0.9 meter (m)</p> <p>1 mile (mi) = 1.6 kilometers (km)</p>	<p><b>LENGTH (APPROXIMATE)</b></p> <p>1 millimeter (mm) = 0.04 inch (in)</p> <p>1 centimeter (cm) = 0.4 inch (in)</p> <p>1 meter (m) = 3.3 feet (ft)</p> <p>1 meter (m) = 1.1 yards (yd)</p> <p>1 kilometer (km) = 0.6 mile (mi)</p>
<p><b>AREA (APPROXIMATE)</b></p> <p>1 square inch (sq in, in<sup>2</sup>) = 6.5 square centimeters (cm<sup>2</sup>)</p> <p>1 square foot (sq ft, ft<sup>2</sup>) = 0.09 square meter (m<sup>2</sup>)</p> <p>1 square yard (sq yd, yd<sup>2</sup>) = 0.8 square meter (m<sup>2</sup>)</p> <p>1 square mile (sq mi, mi<sup>2</sup>) = 2.6 square kilometers (km<sup>2</sup>)</p> <p>1 acre = 0.4 hectare (he) = 4,000 square meters (m<sup>2</sup>)</p>	<p><b>AREA (APPROXIMATE)</b></p> <p>1 square centimeter (cm<sup>2</sup>) = 0.16 square inch (sq in, in<sup>2</sup>)</p> <p>1 square meter (m<sup>2</sup>) = 1.2 square yards (sq yd, yd<sup>2</sup>)</p> <p>1 square kilometer (km<sup>2</sup>) = 0.4 square mile (sq mi, mi<sup>2</sup>)</p> <p>10,000 square meters (m<sup>2</sup>) = 1 hectare (ha) = 2.5 acres</p>
<p><b>MASS - WEIGHT (APPROXIMATE)</b></p> <p>1 ounce (oz) = 28 grams (gm)</p> <p>1 pound (lb) = 0.45 kilogram (kg)</p> <p>1 short ton = 2,000 pounds (lb) = 0.9 tonne (t)</p>	<p><b>MASS - WEIGHT (APPROXIMATE)</b></p> <p>1 gram (gm) = 0.036 ounce (oz)</p> <p>1 kilogram (kg) = 2.2 pounds (lb)</p> <p>1 tonne (t) = 1,000 kilograms (kg) = 1.1 short tons</p>
<p><b>VOLUME (APPROXIMATE)</b></p> <p>1 teaspoon (tsp) = 5 milliliters (ml)</p> <p>1 tablespoon (tbsp) = 15 milliliters (ml)</p> <p>1 fluid ounce (fl oz) = 30 milliliters (ml)</p> <p>1 cup (c) = 0.24 liter (l)</p> <p>1 pint (pt) = 0.47 liter (l)</p> <p>1 quart (qt) = 0.96 liter (l)</p> <p>1 gallon (gal) = 3.8 liters (l)</p> <p>1 cubic foot (cu ft, ft<sup>3</sup>) = 0.03 cubic meter (m<sup>3</sup>)</p> <p>1 cubic yard (cu yd, yd<sup>3</sup>) = 0.76 cubic meter (m<sup>3</sup>)</p>	<p><b>VOLUME (APPROXIMATE)</b></p> <p>1 milliliter (ml) = 0.03 fluid ounce (fl oz)</p> <p>1 liter (l) = 2.1 pints (pt)</p> <p>1 liter (l) = 1.06 quarts (qt)</p> <p>1 liter (l) = 0.26 gallon (gal)</p> <p>1 cubic meter (m<sup>3</sup>) = 36 cubic feet (cu ft, ft<sup>3</sup>)</p> <p>1 cubic meter (m<sup>3</sup>) = 1.3 cubic yards (cu yd, yd<sup>3</sup>)</p>
<p><b>TEMPERATURE (EXACT)</b></p> <p><math>[(x-32)(5/9)] \text{ } ^\circ\text{F} = y \text{ } ^\circ\text{C}</math></p>	<p><b>TEMPERATURE (EXACT)</b></p> <p><math>[(9/5)y + 32] \text{ } ^\circ\text{C} = x \text{ } ^\circ\text{F}</math></p>

## QUICK INCH - CENTIMETER LENGTH CONVERSION

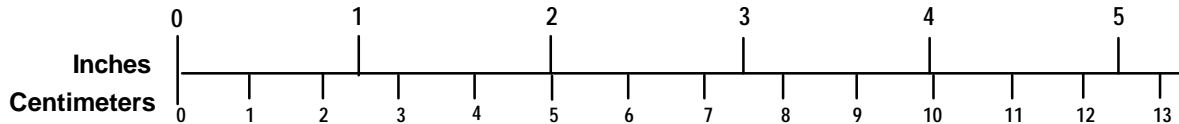

## QUICK FAHRENHEIT - CELSIUS TEMPERATURE CONVERSION

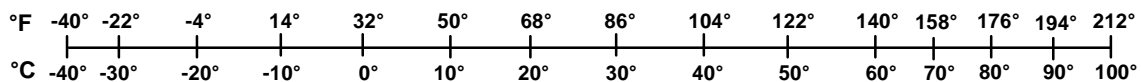

For more exact and or other conversion factors, see NIST Miscellaneous Publication 286, Units of Weights and Measures.  
Price \$2.50 SD Catalog No. C13 10286

Updated 6/17/98

## PREFACE

In recent years there has been increased interest in high speed guided ground transportation (HSGGT). In May of 1991 the state of Texas awarded a franchise for the construction of a high speed rail system linking Dallas/Ft. Worth, San Antonio, and Houston, and in January of 1992 a detailed franchise agreement was signed for construction of a system using the French Train Grande Vitesse (TGV). In June of 1989 the Florida High Speed Rail Commission (now part of the Florida Department of Transportation) recommended awarding a franchise for construction of a maglev system linking Orlando airport and a major attractions area on International Drive in Orlando, and in June of 1991 a franchise agreement was signed by the state of Florida for construction of a system using the German Transrapid TR07. In November of 1992 Amtrak began testing the Swedish X2000 tilt-train on the Northeast Corridor and in 1993 Amtrak will test the German Inter-City Express (ICE) train on the Northeast corridor. In 1991 four contracts were awarded for the development of a U.S. designed maglev system, as part of the National Maglev Initiative. The Intermodal Surface Transportation Efficiency Act (ISTEA) of 1991 provides for the further development of a U.S. designed maglev system. In addition to the current active projects, there have been numerous proposals throughout the country for new high speed systems and for increasing the speeds on current rail corridors.

All of the systems proposed for operation at speeds greater than current practice employ technologies that are different from those used in current guided ground transportation systems. These different technologies include advanced signaling and control systems and lightweight car-body structures for all or most HSGGT systems. The differences in technology, along with the increased potential consequences of an accident occurring at high speeds, require assurances that HSGGT systems are safe for use by the traveling public and operating personnel.

This report on collision safety is part of a comprehensive effort by the Federal Railroad Administration (FRA) to develop the technical information necessary for regulating the safety of high speed guided ground transportation. Other areas currently being studied by the FRA as part of its high speed guided ground transportation safety program include:

- Maglev Technology Safety Assessments (both electromagnetic and electrodynamic)
- Development of Emergency Preparedness Guidelines
- Electromagnetic Field Characteristics
- Guideway Safety Issues
- Automation Safety
- Human Factors and Automation

Collision safety comprises the measures taken to avoid collision and also to assure passenger and crew protection in the event of an accident. The results of this study, presented in the four-volume report, provide a basis for evaluating the collision safety provided by a given HSGGT system. These measures must be evaluated concurrently for a coordinated, effective approach. Based on the results of this study, work is currently planned to evaluate the collision safety of a proposed system and to evaluate the effectiveness of modifications on the collision safety of an existing conventional system.

## **ACKNOWLEDGMENT**

The authors wish to thank David Tyrell, the Technical Monitor for this task, Robert Dorer, other staff of the Volpe National Transportation Systems Center, and Arne Bang and his colleagues at the Federal Railroad Administration for their support and assistance during this project.

## TABLE OF CONTENTS

<u>Section</u>	<u>Page</u>
1. BACKGROUND AND INTRODUCTION.....	1-1
1.1 Background to the Overall Project.....	1-1
1.2 Objective and Scope of Work for the Overall Study .....	1-2
1.3 Content of this Volume .....	1-4
2. DEVELOPMENT OF COLLISION SCENARIOS .....	2-1
2.1 Introduction .....	2-1
2.2 Definitions .....	2-2
2.3 Collision Scenarios .....	2-4
2.4 Review of Past Accidents .....	2-11
2.4.1 FRA Accident Reports .....	2-11
2.4.2 Review of Serious Railroad Accidents in the U.S .....	2-14
2.4.3 Foreign Accidents .....	2-17
2.5 Causes and Consequences of Collisions and Other Accidents .....	2-19
2.5.1 Causes and Consequences of Collisions Between Vehicles or Trains on the Same Guideway .....	2-21
2.5.2 Causes and Consequences of At-Grade Highway Crossing Collisions .....	2-24
2.5.3 Causes and Consequences of Collision with Obstructions on or Fouling the Guideway .....	2-24
2.5.4 Causes and Consequences of Single Train or Vehicle Accidents .....	2-26
3. REVIEW OF FOREIGN HIGH SPEED GUIDED GROUND TRANSPORTATION SAFETY REGULATIONS .....	3-1
3.1 Introduction .....	3-1
3.2 Collision Avoidance .....	3-8
3.2.1 Signal and Train Control Systems .....	3-8
3.2.2 Right-of-Way Security .....	3-25
3.2.3 At-Grade Rail-Highway Crossings .....	3-28
3.2.4 Brake Installation and Performance .....	3-31
3.2.5 Operating and Maintenance Staff Qualifications and Training .....	3-38
3.2.6 Operating. Rules and Practices .....	3-40

## TABLE OF CONTENTS (continued)

<u>Section</u>	<u>Page</u>
3.3 Accident Survivability .....	3-42
3.3.1 Overall Vehicle Structure .....	3-42
3.3.2 Operators' Cab Crashworthiness and Safety .....	3-47
3.3.3 Vehicle Fittings and Equipment .....	3-53
3.3.4 Car and Locomotive Glazing Standards .....	3-56
4. RECOMMENDED GUIDELINES FOR COLLISION AVOIDANCE AND ACCIDENT SURVIVABILITY .....	4-1
4.1 Introduction .....	4-1
4.2 Definition of Equivalent Safety.....	4-1
4.3 Guidelines for Collision Avoidance and Accident Survivability .....	4-15
APPENDIX A - U.S. SERIOUS RAILROAD ACCIDENT DATA .....	A-1
REFERENCES .....	R-1



## LIST OF ILLUSTRATIONS

<u>Figure</u>		<u>Page</u>
3-1	Schematic of German Federal Railways LZB Automatic Train Control System .....	3-16
3-2	Speed Control and Braking Distances on the TGV Atlantique .....	3-18
3-3	Cab Signals Used on French TGV Trains on the Paris-South East High-Speed Line (Speeds in km/h).....	3-19
3-4	General View of Shinkansen Control Center .....	3-23
3-5	Detail of Shinkansen Control Panel .....	3-24
3-6	Comparison of North American and European Car Body Strength Requirements .....	3-44
3-7	Articulation Arrangement of the TGV Atlantique .....	3-46
3-8	TGV-Atlantique Power Car Arrangement .....	3-49
3-9	UIC Standard Projectile for Testing Forward-Facing Cab Windows.....	3-59
4-1	Risk Profiles for Accidents to Man-Made Systems .....	4-3
4-2	Risk Profiles for Passenger Railroad and Airline Operations in the United States.....	4-5

## LIST OF TABLES

<u>Table</u>	<u>Page</u>
2-1	Scenarios for Collisions Between Similiar High-Speed Trains on Same Guideway (Group 1) .....2-5
2-2	Scenarios for Collisions with Obstructions on Guideway (Group 2) .....2-6
2-3	Collision Scenarios - Group 3: Collisions with Dissimilar Train or Vehicle on Same Guideway .....2-8
2-4	Collision Scenarios - Group 4: Single Train Events .....2-9
2-5	Summary of Passenger Train Accidents on Main Track 1985-1987 .....2-12
2-6	Accident Causes and Consequences .....2-20
2-7	Estimated Relationship Between Collision Energy and Damage Severity in Train Collisions .....2-23
3-1	Relationship Between Safety Requirements Categories and Collision Scenarios .....3-2
3-2	High-Speed Rail Rolling Stock Summaries (as of 1/1/92) .....3-9
3-3	High-Speed Rail Infrastructure Summaries (Trains in Service, 1992) .....3-11
3-4	UIC Codes for Signal and Train Control Systems .....3-15
3-5	UIC Codes for Brake Installation and Performance .....3-34
3-6	Description of Principal Brake Types .....3-36
3-7	Overview of HSGGT Brake Systems .....3-37
3-8	Accident Survivability Features of Selected Foreign High-Speed Trains .....3-48
3-9	Engineer Cab Crashworthiness and Safety .....3-52
3-10	Vehicle Interior Fittings and Equipment .....3-55
3-11	Window Glazing Standards .....3-58
4-1	Fatal Accidents U.S. Domestic Passenger Air Service - 1978-1989.....4-6
4-2	Risk Data for U.S. Passenger Railroads and Domestic Airlines .....4-9

## LIST OF TABLES (continued)

<u>Table</u>		<u>Page</u>
4-3	HSGGT Societal Risk Performance Criteria .....	4-10
4-4	Individual Passenger Transportation Risk .....	4-12
4-5	Railroad Employee Fatality Risk .....	4-13
4-6	Trespasser and Grade Crossing Fatalities in U.S. Intercity Rail Operations .....	4-14

## ABBREVIATIONS AND TERMINOLOGY

Many abbreviations are in common use for railroad and governmental organizations and high-speed guided ground transportation systems and their components. This list provides a convenient reference for those used frequently in the different volumes of this report. The same list is used in all volumes but all abbreviations do not appear in all volumes. Note that some abbreviations, particularly those used for different train control systems (ATC, ATCS, ATP, etc.), may not have the same meaning for all users. Commonly accepted meanings are given.

AAR	Association of American Railroads
AIS	Abbreviated Injury Scale
ANF	French railroad equipment manufacturer. Builder of gas-turbine powered train sets
APTA	American Public Transit Association
AREA	American Railway Engineering Association
ASTREE	Automation du Suivi en Temps (French on-board train control system)
ATB	Articulated Total Body - computer analysis code used to model human body dynamics
ATC	Automatic Train Control - systems which provide for automatic initiation of braking if signal indications are not obeyed or acknowledged by train operator. Usually combined with cab signals
ATCS	Advanced Train Control Systems - a specific project of the AAR to develop train control systems with enhanced capabilities
ATD	Anthropomorphic Test Device (Dummy)
ATO	Automatic Train Operation - a system of automatic control of train movements from start-to-stop. Customarily applied to rail rapid transit operations
ATP	Automatic Train Protection - usually a comprehensive system of automatic supervision of train operator actions. Will initiate braking if speed limits or signal indications are not obeyed. All ATP systems are also ATC systems
AVE	Alta Velocidad Espagnol - Spanish high speed rail system currently comprising one line between Madrid and Seville

## ABBREVIATIONS AND TERMINOLOGY (continued)

AWS	Automatic Warning System - a simple cab signalling and ATC system used on British Rail
BART	Bay Area Rapid Transit (San Francisco, CA)
BN	Burlington Northern (Railroad)
BR	British Rail
CFR	Code of Federal Regulations
CPU	Central Processing Unit (core unit of a microprocessor)
CTC	Centralized Train Control - system of supervision of railroad operations from a central location
DB	Deutsche Bundesbahn - German Federal Railways
DIN	Deutsches Institut für Normung - German National Standards Institute
DLR	Docklands Light Railway, London, U.K.
EMD	Electro-Motive Division of General Motors (Locomotive Manufacturers)
EMI	Electro-Magnetic Interference - usually used in connection with the interference with signal control circuits caused by high power electric traction systems
FAA	Federal Aviation Administration (United States)
FAR	Federal Aviation Regulations
FCC	Federal Communications Commission (United States)
FEA	Finite Element Analysis
FHWA	Federal Highway Administration (United States)
FMEA	Failure Modes and Effects Analysis
FMVSS	Federal Motor Vehicle Safety Standards (United States)
FNC	Frazer-Nash Consultancy

## ABBREVIATIONS AND TERMINOLOGY (continued)

FRA	Federal Railroad Administration of the United States Department of Transportation
FTA	Federal Transit Administration (United States)
g	gravitational acceleration, equivalent to 9.81 m/sec <sup>2</sup> or 32.2 ft/sec <sup>2</sup>
HA	Hybrid Analysis (for collision analysis)
HIC	Head Injury Criterion
HSGGT	High-Speed Guided Ground Transportation
HSR	High-Speed Rail
HST	High-Speed Train - British Rail high-speed diesel-electric trainset
HYGE	High-g (high acceleration) sled testing facility
ICE	Inter-City Express - a high speed train-set developed for German Federal Railways consisting of a locomotive at each end and approximately 10 intermediate passenger cars
IIT	Illinois Institute of Technology
ISO	International Standards Organization
Intermittent	A term used in connection with ATC and ATP systems to describe a system that transmit instructions from track to train at discrete points rather than continuously
J	Joule: metric (SI) unit of energy, equivalent to a force of one Newton (N) moving through a distance of one meter (m)
JNR	Japanese National Railways - organization formerly responsible for rail services in Japan. Was reorganized as the Japan Railways (JR) Group on April 1, 1987, comprising several regional railways, a freight business and a Shinkansen holding company
JR	Japan Railways - see JNR

## ABBREVIATIONS AND TERMINOLOGY (continued)

LCX	Leaky co-axial cables - LCX cables laid along a guideway can provide high quality radio transmission between the vehicle and wayside. LCX is more reliable than air-wave radio, and can be used where air waves cannot, for example, in tunnels
LGV	Ligne a Grand Vitesse - French newly-built high-speed lines. See also TGV
LMA	Lumped Mass Analysis
LRC	Light Rapid Comfortable. A high-speed tilt-body diesel-electric train-set developed in Canada
LZB	Linienzugbeeinflussung - Comprehensive system of train control and automatic train protection developed by German Federal Railways
Maglev	Magnetic Levitation, usually used to describe with a guided transportation system using magnetic levitation and guidance
MARTA	Metropolitan Atlanta Rapid Transit Authority
MU	Multiple Unit. A train on which all or most passenger cars are individually powered and no separate locomotive is used
N	Newton: metric (SI) unit of force equivalent to the force needed to accelerate a mass of one kilogram (kg) at one meter per second <sup>2</sup>
NBS	Neubaustrecken - German Federal Railway newly-built high-speed lines
NCAP	New Car Assessment Program of the National Highway Safety Traffic Administration
NHTSA	National Highway Traffic Safety Administration (United States)
NTSB	National Transportation Safety Board (United States)
PATCO	Port Authority Transit Corporation (Lindenwold Line)
PHA	Preliminary Hazard Analysis
PSE	Paris Sud-Est. The high-speed line from Paris to Lyon on French National Railways
QRA	Quantitative Risk Analysis

## ABBREVIATIONS AND TERMINOLOGY (continued)

RENFE	Rede Nacional de los Ferrocarriles Espanoles - Spanish National Railways
ROW	Right-of-Way: strip of land on which an HSGGT guideway is constructed.
SACEM	System to aid control and maintenance. French ATO/ATP system applied to high density Paris commuter rail lines
SBB	Schweizerische Bundesbahnen - Swiss Federal Railways
SELTRAC	Moving-block signaling system developed by Alcatel, Canada
Shinkansen	Japanese high speed wheel-on-rail systems
SI	International system of metric units based on the meter (m) kilogram (kg) and second as primary units
SJ	Statens Jarnvagar - Swedish State Railways
SNCF	Societe Nationale des Chemin de Fer Francais - French National Railways
SSI	Solid State Interlocking in a railroad signalling system
STWR	(Vehicle) Strength to Weight Ratio
TALGO	Spanish articulated lightweight trainset featuring single axle trucks and passive pendular tilt
TGV	Train Grand Vitesse - French High-Speed Train. Also used to refer to complete French high-speed train system
TR	Transrapid - German electro-magnetic maglev design
UIC	Union Internationale de Chemins de Fer (International Union of Railways)
U.K.	United Kingdom
ULA	Ultimate Load Analysis (for collision analysis)
UMTA	Urban Mass Transportation Administration of the U.S. Department of Transportation. The name of this agency has now changed to the Federal Transit Administration (FTA)



## ABBREVIATIONS AND TERMINOLOGY (continued)

U.S. or US	United States
Vital	A "vital" component in a signal and train control system is a safety-critical component which must be designed to be fail safe and/or have a very low incidence of unsafe failures.
VNTSC	Volpe National Transportation Systems Center
WMATA	Washington Metropolitan Area Transit Authority

Acronyms for individual computer analysis packages are not provided in this list.

# 1. BACKGROUND AND INTRODUCTION

## 1.1 BACKGROUND TO THE OVERALL PROJECT

There is growing interest in High Speed Guided Ground Transportation (HSGGT) systems in the United States for applications in major intercity passenger travel corridors. HSGGT systems may use advanced wheel-on-rail railroad technology or magnetic levitation technology. Proposed maximum operating speeds are in the range of 250 to 500 km/h (155 to 311 mph), which exceeds the maximum of 177 km/h (110 mph) normally permitted on conventional railroads in the United States today. Examples of active projects include the application of the French Train Grande Vitesse (TGV) to the Dallas-Houston corridor in Texas, a demonstration of German Transrapid Magnetic Levitation (maglev) technology in Orlando, Florida, and higher speeds and the use of tilt train technology on the Northeast Corridor between Boston and Washington.

The Federal Railroad Administration (FRA) is closely involved in these developments. Under the Rail Safety Improvement Act of 1988, the FRA is responsible for ensuring the safety of any HSGGT system operated in the United States. The Act defines a railroad to include "all forms of non-highway ground transportation that run on rails or electromagnetic guideways," thus confirming the FRA's responsibility for maglev HSGGT systems as well as wheel-on-rail systems. The FRA together with other federal and state government agencies is also actively involved in studies of maglev technologies under the National Maglev Initiative, and is performing a variety of other technical and economic studies of HSGGT systems.

With regard to safety, the FRA, supported by the Volpe National Transportation Systems Center (VNTSC), is carrying out a series of studies on different aspects of HSGGT safety. The overall objective of these studies is to identify and formulate a proper response to safety concerns associated with HSGGT systems of different types. The results of these studies will help the FRA ensure the safety of passengers and staff of HSGGT systems. HSGGT system developers also benefit from the availability of clear safety requirements against which to plan HSGGT system design, construction, and operation.

One area of safety concern arises from the differences between HSGGT systems and conventional railroad systems operated in the U.S. In addition to the higher maximum speed, the HSGGT systems may have been developed with technical requirements which differ from those applicable in the U.S., or may embody technology not used in conventional U.S. railroad systems. Because of the differences in technology, many safety-related requirements (regulations, standards, and practices) applicable to conventional U.S. railroads do not fully meet the needs of HSGGT safety assurance. Aspects of present safety requirements where the development of new or amended requirements may be necessary include the following:

- Current general railroad safety requirements apply only to speeds up to 177 km/h (110 mph). Higher speeds, up to 200 km/h (124 mph), are permitted under a waiver of present regulations on portions of the Northeast Corridor between New York and Washington, DC, but are not normal practice. Requirements are absent for speeds exceeding 200 km/h (124 mph).
- Many existing requirements are for design rather than performance. Design requirements typically specify loads, dimensions, and materials to be used in the design and

manufacture of a specific component and are unique to one technology or system concept. Design requirements have the advantage that compliance can be easily verified, but may be difficult or impossible to transfer to other technologies. The technology of many HSGGT subsystems and components differs greatly from conventional railroad technology, and may not be compatible with existing design requirements.

- System safety concepts followed in the HSGGT systems proposed for application in the United States differ considerably from conventional U.S. railroad practice. The application of safety requirements that evolved for conventional railroads may be unnecessarily restrictive, or may fail to ensure an adequate safety level.

The limitations of existing railroad safety requirements mean that new safety requirements are needed for HSGGT systems that assure an adequate safety performance but which do not unnecessarily constrain the application of innovative technology. This report presents the results of one of a number of studies being carried out for the FRA on appropriate safety requirements for HSGGT systems.

The subject of the study is the adequacy of measures taken in HSGGT systems to avoid collisions, and the adequacy of measures to protect occupants of an HSGGT vehicle from the consequences of a collision or other form of accident. In particular, the study addresses ways of jointly specifying and evaluating HSGGT collision avoidance and accident survivability performance to ensure that overall system safety performance requirements are met.

The term "collision avoidance" covers all subsystems of an HSGGT system that are designed to prevent collisions between vehicles or trains, collisions between vehicles and obstructions on the guideway, and collisions with objects thrown or shot at a vehicle. "Avoidance" particularly includes the performance of train or vehicle control systems. The term "accident survivability" covers all features of the HSGGT system designed to minimize the severity of consequences of an accident should one occur. "Survivability" particularly includes the crashworthiness features of vehicles and vehicle interiors.

The FRA's overall goal is to ensure that HSGGT systems are at least as safe as comparable conventional railroad systems. A four-step approach, detailed in Section 1.2 below, has been taken to develop safety specifications and guidelines for collision avoidance and accident survivability. A major product of this study is a performance-based safety specification that, when applied to an HSGGT system, will ensure that the FRA's system safety goal is achieved. Such a specification can be applied in principle to any HSGGT technology, and overcomes the difficulty of the technology-specific nature of many existing safety requirements. The design of the specification emphasizes the development of system safety performance requirements, as well as the individual component requirements, and permits the HSGGT system designer to achieve a cost-effective balance between collision avoidance and accident survivability.

## **1.2 OBJECTIVE AND SCOPE OF WORK FOR THE OVERALL STUDY**

The overall objective of the study is to develop a specification for HSGGT system collision avoidance and accident survivability. This specification, as far as possible, should be performance based, not specific to any HSGGT technology, and permit alternative approaches to balancing the effectiveness of the collision avoidance system and accident survivability systems

incorporated into a particular HSGGT application. The specification must ensure that HSGGT systems provide a level of safety that is equivalent to or better than current intercity passenger railroad systems operating under present safety regulations, standards, and practices. The specifications have been developed in a four-step work program.

1. **Evaluation of the collision threat.** This evaluation includes identifying collision scenarios against which protection is required and their causes and consequences, reviewing and summarizing foreign HSGGT safety requirements to provide guidance for developing safety requirements for U.S. applications, and developing guidelines for selecting and jointly evaluating collision avoidance systems and accident survivability measures incorporated into a particular HSGGT system. The results of this evaluation are contained in the first volume of the final report.
2. **A detailed review of the state of the art in collision avoidance.** This review includes descriptions of the architecture and details of train or vehicle control systems used to prevent collisions on a guided system, and measures to protect the guideway from obstructions. The implications of different collision avoidance system choices for system capacity and reliability of operation are also discussed. Finally, recommended guidelines are provided for evaluating and selecting collision avoidance systems for HSGGT application. The results of this review are contained in Volume 2 of the final report.
3. **A detailed review of the state of the art in accident survivability.** This review includes vehicle structural design practices used to mitigate or control the effects of a collision, such as minimum strength requirements and energy absorption techniques; the design of vehicle interiors to minimize injury in a collision or other form of accident, human injury criteria used to evaluate accident survivability performance; and testing and modelling techniques for accident survivability assessment. The review concludes with guidelines for accident survivability practice with regard to HSGGT vehicle structural and interior design, and guidelines for evaluating vehicle accident survivability performance through modelling and testing. The results of this review are contained in Volume 3 of the final report.
4. **Development of a proposed specification for collision avoidance and accident survivability.** The specification is designed to ensure a level of safety equivalent to or better than that currently provided by intercity passenger railroad services. The specification is largely performance-based and is not specific to any particular HSGGT technology or system concept. The specification is designed so that the HSGGT system designer is able, within certain limits, to achieve an appropriate balance between the collision avoidance and accident survivability features of a particular system. The specification, together with an accompanying explanation of the underlying approach and structure, is provided in Volume 4 of the final report.

It should be noted that while this study addresses a major group of safety concerns, it is not an overall HSGGT systems safety study. In particular, it does not address avoidance of non-collision accidents (for example those due to vehicle defects, guideway defects, or vehicle fires) or requirements for emergency response following an accident. Concurrent studies by the FRA and VNTSC are addressing related guided ground transportation safety issues including studies of accident risks where an HSGGT system shares a right-of-way with other transportation systems,

the safety issues associated with using microprocessors in safety-critical HSGGT functions, and the human factors safety issues arising in highly automated systems.

### **1.3 CONTENT OF THIS VOLUME**

This first volume of the final report describes the collision threats to which an HSGGT system may be exposed and recommends guidelines for the selection and evaluation of collision avoidance and accident survivability measures to counter the collision threats. Targets for collision avoidance and accident survivability performance to meet the goal of "equivalent-safety" compared with existing railroad intercity passenger operations are developed.

Chapters 2, 3, and 4 of this volume address the identification of HSGGT accident scenarios, describe measures taken on foreign HSGGT systems to provide adequate protection against the accident risks associated with the scenarios, and provide guidelines for the joint design and evaluation of collision avoidance and accident survivability for an HSGGT system.

Chapter 2 develops collision and accident scenarios to which an HSGGT system may be exposed, together with likely causes and representative consequences for each scenario. The scenario development is supported by descriptions of serious accidents on both U.S. and foreign railroad systems.

Chapter 3 contains a description of foreign railroad safety practices for high-speed systems. This particularly includes vehicle structural strength requirements, vehicle interiors, signal and train control systems, braking systems, and right-of-way security. Relevant safety-related codes and regulations are identified, and specific practices adopted by different systems are described.

Chapter 4 provides guidelines for the collision avoidance and accident survivability performance of an HSGGT system. This includes a discussion of overall performance requirements based on the principle of "equivalent safety" - ensuring that HSGGT overall safety performance is equivalent to or better than that currently achieved on intercity railroads in the United States - and a discussion of alternative means of achieving the required safety performance with respect to the collision threats discussed in Chapter 2.

## 2. DEVELOPMENT OF COLLISION SCENARIOS

### 2.1 INTRODUCTION

This chapter identifies and describes the collision scenarios to which an HSGGT system may be exposed, including collisions with other trains and vehicles and with various kinds of obstruction on or adjacent to the guideway.

The collision scenarios provide a framework for the studies of collision avoidance and accident survivability technology, and development of the corresponding guidelines and specifications.

The following information is developed for each scenario:

- A description of the scenario
- Examples of actual accidents that fit the scenario
- A discussion of the causes and consequences of these collisions

Review of past railroad accidents has been carried out to support scenario development. A review of main line railroad accidents involving passenger trains in the United States and of notable serious accidents in both the U.S. and overseas was used to identify accident scenarios and corresponding causes and consequences.

Important objects of the scenario description are the guideway and right-of-way configuration, train composition, and operating conditions under which the collision could occur. The collision hazards that an HSGGT system is exposed to and must be protected from are a function of these configurations and operating conditions. For example, a wheel-on-rail HSGGT system that shares a guideway with other train types is exposed to more collision scenarios than one that does not share a guideway, but is otherwise similar.

This study addresses only HSGGT systems (both wheel-on-rail and maglev) that are currently in service or are being proposed for commercial service in the next decade or so. These systems have proposed maximum operating speeds of up to 500 km/h (310 mph). More advanced HSGGT developments, that involve speeds over 500 km/h (310 mph) and new vehicle, guideway, propulsion, and control concepts are not addressed.

Collision situations that are caused by events on a transportation mode in a shared right-of-way are included among these scenarios. However, detailed examination of these scenarios is the subject of a separate study by VNTSC [Reference 1]. Situations where another transportation right-of-way crosses a HSGGT guideway (over, under, or at-grade) are not considered shared right-of-way situations and are included in this analysis. Such systems could include a highway, a waterway, a hazmat pipeline, and conventional railroad and mass transit systems.

The collision scenario definitions are independent of the types of collision avoidance systems used and accident survivability features of a specific HSGGT system.

Finally, this analysis focusses on those situations that can lead to casualties to occupants through sudden deceleration of the HSGGT vehicle or train, or through impact damage to the vehicle's

structure or equipment. Other kinds of hazard (such as a fire or electric shock), and post-accident events and actions (fire, evacuation, emergency response) are not addressed.

## 2.2 DEFINITIONS

A number of guided transportation terms have been developed for this study, not all of which will be familiar to or have the same meaning for all readers. The following definitions are used in the reports on this study.

A **vehicle-section** is the smallest individual structural unit of a vehicle or a train, and is connected to other vehicle sections by a coupling that allows relative movement in at least one rotational or linear axis.

A **vehicle** is made up of one or more vehicle-sections and is the smallest element of a train that can be attached or detached in service, or operated independently. Vehicle-sections can only be detached from each other in a workshop. By this definition, a French TGV train-set is termed a vehicle.

A **train** is made up of one or more coupled vehicles. The conventional railroad term, consist, is identical to train.

**End vehicles** or **vehicle-sections** are found at the leading or trailing ends of a train. They may be structurally or functionally different from intermediate vehicles or vehicle-sections, which are never found at the ends of a train. Some end-vehicles are equipped with operating controls and function as a cab vehicle (see below).

A **cab vehicle** is either the end vehicle of a multiple unit train (see below), or an unpowered end vehicle having a set of operator's controls. Unpowered cab vehicles, also known as driving-trailers, are normally used at one end of trains operated on the push-pull principle, with a locomotive at the other end. The Swedish X2000 is an example of a push-pull train-set, with a locomotive at one end and a cab vehicle at the other.

A **locomotive or power vehicle** is a vehicle or vehicle-section that contains only or primarily propulsion equipment. To date, power vehicle use has been confined to wheel-on-rail HSGGT systems. Power vehicles usually include an operator's cab and are situated at the ends of a train, but this does not have to be the case. Conceptually, it is possible to situate the locomotive in the middle of a train, with cab vehicles at each end.

**Multiple Unit** (MU) trains are those in which propulsion equipment is installed on most or all vehicle-sections in the train. By this definition, trains of Transrapid Maglev vehicles are multiple units, as are the various series of Japan Rail's Shinkansen trains and the Italian Pendolino (ETR 450). A normal characteristic of MU trains is that end and intermediate vehicles have similar structures and mass, and all contain passenger accommodations.

All types of vehicle run on a **guideway**, which interacts with the vehicle to provide lateral and vertical guidance. Interaction with the guideway may be through wheels or levitation and guidance magnets, and active control systems may be used in the support or guidance system (for example, to control the magnet air gap). However, the primary means of reacting support and

guidance forces must be through the guideway structure. By this definition, an aircraft operating under the control of fully automatic landing systems would not be regarded as following a guideway. The guideway may also include elements of the propulsion system, such as the stator of a linear synchronous motor used on a maglev system.

The principal guideway configurations used by HSGGT systems at an advanced development stage are:

- Conventional wheel-on-rail railroad
- Beam-type maglev guideway straddled by the vehicle (e.g., Transrapid)
- Trough-type maglev guideway partially surrounding the vehicle (e.g., Japan Railways' superconducting maglev system)

Any type of guideway may be constructed at-grade, be supported on an elevated structure, or pass through a tunnel.

HSGGT vehicles or trains or vehicles may share the guideway with vehicles or trains providing different kinds of service and having different structural characteristics and masses. On a shared guideway, trains or vehicles of different types follow one another on the same guideway, subject to an adequate separation maintained by the signal system. If different service types are segregated by time of day, then the guideway is not defined as shared. Vehicles that may share a guideway with HSGGT vehicles or trains include:

- Maintenance or service vehicles - use of such vehicles is possible on all guideway types.
- Other kinds of vehicles and trains. This is most likely to arise when wheel-on-rail HSGGT trains share track with conventional passenger or freight trains. Mixed passenger and freight maglev service on the same guideway could be defined as a shared guideway situation if the weight and structural characteristics of maglev freight vehicles differ significantly from passenger-carrying vehicles.

**Shared right-of-way** exists when other transportation modes or utilities operate adjacent and parallel to the HSGGT guideway. Modes sharing a right-of-way can include highway, conventional rail lines of all kinds (freight, passenger, transit), pipelines, overhead electric utility lines, and waterways. A "shared right-of-way" situation exists whenever the modes are near enough to potentially interfere with one another during normal operation, or in an emergency situation. The interference can include physical intrusion of one system on another, or electromagnetic interference with electronic or communication systems.

**A dedicated right-of-way** is one that only includes one or more identical guideways used by similar HSGGT trains under common control.

**Similar trains** are trains made up of vehicles that are:

- of common cross-section;
- built to the same "accident survivability" requirements, and using the same approach to meet these requirements; and
- of the same train type (e.g., multiple unit, locomotive hauled).



The weight and length of individual vehicles and the number of vehicles in a train may vary within reasonable limits.

### 2.3 COLLISION SCENARIOS

Four groups of collision scenarios have been developed.

1. Collision with a similar high-speed train or vehicle on the same guideway.
2. Collision with an obstruction on the guideway, an object propelled at the train or intrusions from an adjacent guideway or mode of transportation in a shared right-of-way.
3. Collision with a dissimilar train or vehicle on the same guideway.
4. Single-train events, usually involving a loss of support and guidance followed by a sudden stop. Such events can be accompanied by a collision with structures adjacent to the guideway. Examples of single-train events include derailments of conventional wheel-on-rail trains, or a loss of magnetic levitation or guidance of a maglev vehicle due to a magnet failure (e.g., due to an air gap sensor failure, or quenching of a superconducting magnet).

These four main groups are divided into individual scenarios or sub-scenarios as listed in Tables 2-1 - 2-4.

The tables give the following information about each scenario:

- Scenario title - a few words describing the scenario
- Types of HSGGT systems to which the scenario is applicable. Some scenarios are defined as being applicable only to maglev or wheel-on-rail HSGGT systems. However, most scenarios are applicable to all HSGGT system types.
- Types of train or obstruction involved. One train is always a high-speed train. The obstruction may be another high-speed train, a different type of train, or an object, not a train, on the same guideway.
- Nature of the colliding vehicle or vehicles. This is given using the definitions listed in Section 2.2 above, for example, passenger vehicle, cab vehicle, power vehicle, or locomotive.
- Mass and type of obstruction, if the collision is with an obstruction.
- Typical maximum speeds of the trains involved. This could be the maximum speed of operation (maximum in the tables) at which the train is exposed to a particular scenario or some lesser speed, as appropriate. A speed range is given in situations where it is reasonable to expect that maximum speed will be restricted, but the exact speed cannot be determined.

**Table 2-1. Scenarios for Collisions Between Similiar High-Speed Trains on Same Guideway (Group 1)**

Ref	Title and Description(1)(2)	Colliding Vehicles		Speed	
		Train 1	Train 2	Train 1	Train 2
1-1	Collision between power vehicles a. Low Speed b. Intermediate Speed c. High speed, one train d. High speed, both trains	Power Vehicle Power Vehicle Power Vehicle Power Vehicle	Power Vehicle Power Vehicle Power Vehicle Power Vehicle	10 km/h 50 km/h Maximum <sup>3</sup> Maximum	0 0 0 Maximum
1.2	Collision between power vehicle and a cab or passenger vehicle a. Low Speed b. Intermediate Speed c. High Speed, one train d. High Speed, both trains	Power Vehicle Power Vehicle Power Vehicle Power Vehicle	Cab/Pass. Vehicle Cab/Pass. Vehicle Cab/Pass. Vehicle Cab/Pass. Vehicle	10 km/h 50 km/h Maximum Maximum	0 0 0 Maximum
1.3	Collision between cab or passenger vehicles a. Low Speed b. Intermediate Speed c. High Speed, one train d. High Speed, both trains	Cab/Pass. Vehicle Cab/Pass. Vehicle Cab/Pass. Vehicle Cab/Pass. Vehicle	Cab/Pass. Vehicle Cab/Pass. Vehicle Cab/Pass. Vehicle Cab/Pass. Vehicle	10 km/h 50 km/h Maximum Maximum	0 0 0 Maximum

<sup>1</sup>Both trains are of the maximum weight normally operated

<sup>2</sup>The scenarios apply to all HSGGT systems

<sup>3</sup>Maximum is the maximum speed normally operated

**Table 2-2. Scenarios for Collisions with Obstructions on Guideway (Group 2)**

Ref.	Description	Applicability	Nature of Obstruction	Lead Vehicle of HS Train	HS Train Speed	Assumed Mass	
						HS Train	Obstruction
2.1a	At-grade crossing collision	Wheel-on-rail	Truck/bus	Power vehicle	177 km/h	Maximum <sup>2</sup>	36240 kg
2.1b	At-grade crossing collision	Wheel-on-rail	Truck/bus	Cab vehicle	177 km/h	Maximum	36240 kg
2.1c	At-grade crossing collision	Wheel-on-rail	Automobile	Power vehicle	177 km/h	Maximum	2000 kg
2.1d	At-grade crossing collision	Wheel-on-rail	Automobile	Cab vehicle	177 km/h	Maximum	2000 kg
2.2a	Animal on guideway	All HSGGT systems	Cow	Power vehicle	Maximum <sup>1</sup>	Maximum	500 kg
2.2b	Animal on guideway	All HSGGT systems	Cow	Cab vehicle	Maximum	Maximum	500 kg
2.3a	Person on guideway	All HSGGT systems	Person	Power vehicle	Maximum	Maximum	100 kg
2.3b	Person on-guideway	All HSGGT systems	Person	Cab vehicle	Maximum	Maximum	100 kg
2.4a	Maintenance equipment on guideway	All HSGGT systems	Hi-rail vehicle, or inspection vehicle	Power vehicle	Maximum	Maximum	Heaviest equipment operated
2.4b	Maintenance equipment on guideway	All HSGGT systems	Hi-rail vehicle, or inspection vehicle	Cab vehicle	Maximum	Maximum	Heaviest equipment operated
2.5a	Rocks or debris on guideway	All HSGGT systems	Miscellaneous	Power vehicle	Maximum	Maximum	Wheel-on-rail 200 kg Maglev 50 kg
2.5b	Rocks or debris on guideway	All HSGGT systems	Miscellaneous	Cab vehicle	Maximum	Maximum	Wheel-on-rail 200 kg Wheel-on-rail 50 kg
2.6a	Overrun at guideway end	All HSGGT systems	Dead end	Power vehicle	50 km/h	Maximum	Infinite
2.6b	Overrun at guideway end	All HSGGT systems	Dead end	Cab vehicle	50 km/h	Maximum	Infinite

**Table 2-2. Scenarios for Collisions with Obstructions on Guideway (Group 2) (continued)**

Ref.	Description	Applicability	Nature of Obstruction	Lead Vehicle of HS Train	HS Train Speed	Assumed Mass	
						HS Train	Obstruction
2.7a	Guided vehicle encroachment (adjacent guideway, or shared r.o.w.)	All HSGGT systems	HSGGT vehicle or conventional railroad	Power vehicle	Maximum	Maximum	50,000 kg
2.7b	Guided vehicle encroachment (adjacent guideway, or shared r.o.w.)	All HSGGT systems	HSGGT vehicle or conventional railroad	Cab vehicle	Maximum	Maximum	50,000 kg
2.7c	Highway vehicle encroachment <sup>3</sup>	All HSGGT systems	Auto or light truck	Power vehicle	Maximum	Maximum	2000 kg
2.7d	Highway vehicle encroachment <sup>3</sup>	All HSGGT systems	Auto or light truck	Cab vehicle	Maximum	Maximum	2000 kg
2.8	Gunfire to front or side of train <sup>2</sup>	All HSGGT systems	"FRA" bullet	N/A	N/A	N/A	0.22g bullet
2.9	Object dropped in front of train	All HSGGT systems	Rock, cinder block	Cab or power vehicle	Maximum	N/A	T.B.D.
Notes: 1. Maximum speed is the maximum normally operated on the HSGGT system. 2. Maximum mass is that of the largest train normally operated on the HSGGT system. 3. Not at grade crossing.							

**Table 2-3. Collision Scenarios - Group 3: Collisions with Dissimilar Train or Vehicle on Same Guideway**

	Title and Description	Guideway Configurations Applicability	Types of Train		Colliding Vehicles		Speed		Typical Mass	
			Train 1	Train 2	Train 1	Train 2	Train 1	Train 2 <sup>1</sup>	Train 1	Train 2
3.1	HS train collision with conventional pass train, locomotive leading Power vehicle leading on HS train Cab/pass vehicle leading on HS train	Wheel-on-rail only								
a			HS	Pass	Power	Loco	Maximum operated on shared guideway	0	Maximum <sup>3</sup>	750t
b			HS	Pass	Cab/Pass	Loco		0	Maximum	750t
3.2	As 3.1 with cab car on conventional train Power vehicle leading Cab vehicle leading	Wheel-on-rail only								
a			HS	Pass	Power	Cab	Maximum operated on shared guideway	0	Maximum	750t
b			HS	Pass	Cab/Pass	Cab		0	Maximum	750t
3.3	HS train collision with conventional freight train(2) Loco leading Cab vehicle leading	Wheel-on-rail only								
a			HS	Freight	Power	Loco	Maximum operated on shared guideway	0	Maximum	10,000t
b			HS	Freight	Cab/Pass	Loco		0	Maximum	10,000t

Notes: 1. All scenarios assume moving HS train and stationary conventional train. Additional scenarios addressing the reverse situation (stationary HS train) or a head-on collision with both trains moving could be added  
2. The freight train collision scenarios assume that the loco is the colliding vehicle on the freight train. An alternative scenario is a "rear end" collision where the high-speed train strikes a freight car, but is likely to be less severe than a collision with a locomotive.  
3. Maximum mass is that of the largest train normally operated on the HSGGT system.

**Table 2-4. Collision Scenarios - Group 4: Single Train Events**

<b>Ref.</b>	<b>Title/Description</b>	<b>Applicability</b>	<b>Lead Vehicle of Train</b>	<b>HS Train Speed<sup>1</sup></b>	<b>Typical Mass<sup>2</sup></b>
4. 1a	Loss of levitation or guidance	Maglev	Power vehicle	Maximum	Maximum
4. 1b	Loss of levitation or guidance	Maglev	Cab vehicle	Maximum	Maximum
4.2a	Derailment, no collision	Wheel-on-rail systems	Power vehicle	Maximum	Maximum
4.2b	Derailment, no collision	Wheel-on-rail systems	Cab vehicle	Maximum	Maximum
4.3a	Derailment + collision with structure	Wheel-on-rail systems	Power vehicle	Maximum	Maximum
4.3b	Derailment + collision with structure	Wheel-on-rail systems	Cab vehicle	Maximum	Maximum
Note:	Causes of derailments are not the subject of this study, but typically include track and vehicle defects, human error such as excessive speed for a given guideway geometry, and miscellaneous causes such as vandalism.				

<sup>1</sup>Maximum speed is the highest speed routinely attained in normal operation.

<sup>2</sup>Maximum mass is that of the largest vehicle or train regularly operated in normal service.

- Typical maximum masses of the train or trains involved. Often this will be the weight of the largest train normally operated, shown as "maximum" in the tables.

The scenarios are independent of the structural properties of the high-speed vehicles or trains. However, conventional U.S. trains in collision scenarios in Group 3 are assumed to be designed according to current North American regulations, standards, and practices. Discussion of the rationale behind the selection of collision scenarios is provided below.

Table 2-1 shows four severity levels of collision between similar HSGGT trains. Multiple scenarios are needed because there will be both different frequencies of occurrence and different expectations regarding survivability performance for the different scenarios. For example, the lowest speed scenario is characteristic of a collision resulting from an error during switching activities. A normal expectation regarding train performance in such a collision would be no casualties and only minor structural damage. The intermediate speed scenario is characteristic of a collision on a normally automated system working in back-up mode under manual control. A normal expectation of survivability performance in such a collision might be avoidance of any serious injuries. The two high-speed scenarios are included as worst-case events. The consequences of these collisions would be severe and the emphasis will be on ensuring that the performance of collision avoidance systems is such that the occurrence of a high-speed collision is extremely unlikely.

The scenarios covering collision with obstructions, listed in Table 2-2, are based primarily on experience in existing railroad systems. All these scenarios occur regularly on existing guided systems, as indicated by the review of conventional railroad accidents in the United States and elsewhere, described in Section 2.4. Thus, each scenario must be adequately addressed by means of avoidance or survivability measures on HSGGT systems. The inclusion of at-grade highway crossing collisions reflects the fact that wheel-on-rail HSGGT trains may operate over conventional tracks with grade crossings, usually at conventional rather than high speeds. If operations over at-grade highway crossings are proposed, the likelihood of such collisions and their consequences must be considered in an overall safety assessment. The speed specified in the scenario, 177 km/h (110 mph), is the highest currently permitted over at-grade highway crossings in the United States.

The scenarios for collisions with dissimilar vehicles or trains on the same guideway, listed in Table 2-3, are all specifically for the operation of wheel-on-rail HSGGT trains on conventional railroads among conventional railroad traffic. Such operations are envisaged in some proposals for U.S. HSGGT projects, for example, to provide access to a city center without having to acquire a new right-of-way. No equivalent operation with maglev HSGGT systems are contemplated, and no scenarios have been developed.

The last group of scenarios for single train events is shown in Table 2-4. Only survivability aspects of these scenarios are being investigated in this study. The causes and ways of reducing the occurrence of these accidents have not been studied.

The scenarios are formulated to cover all possible collision and accident situations that might arise in HSGGT operations. An individual HSGGT system or application typically will be exposed to only some of these scenarios, depending on the system configuration and the types of trains operated. For example, a system that is totally segregated and only operates multiple-unit

trains (such as the Japanese Shinkansen or Transrapid Maglev system) does not need to consider safety assessment analysis scenarios for at-grade highway crossing collisions, collisions with dissimilar trains or vehicles, or scenarios in which colliding vehicles include a power vehicle. A system that uses train-sets consisting of several passenger vehicles between two power vehicles (such as the French TGV or the German ICE) does not need to consider cab-vehicle collision scenarios in a safety assessment. Otherwise, an HSGGT system in a particular application must be designed so that the combination of collision avoidance measures and accident survivability features of the vehicles and train ensure an adequately low incidence of accident casualties among train occupants, with consideration given to all applicable scenarios and their likely frequency of occurrence.

## **2.4 REVIEW OF PAST ACCIDENTS**

A review of past accidents was undertaken to confirm the completeness of the accident scenarios defined in Section 2.3, and to provide information for the descriptions of accident causes and consequences listed in Section 2.5. The review has three parts. The first part is an analysis of all accidents involving passenger trains in the U.S. reported to the FRA in the three-year period 1985-1987. The second is an analysis of serious accidents involving passenger trains in the U.S. investigated by the National Transportation Safety Board (NTSB) over approximately the last twenty years. The third is a review of a few serious railway accidents in Europe that have resulted in changes to rail safety practice or have become "design-cases" for safety performance.

### **2.4.1 FRA Accident Reports**

The results of the review of railroad accidents reported to the FRA over the three years 1985-1987 are given in Table 2-5. The accidents are listed by scenario, as defined in Tables 2-1 to 2-4. Under FRA reporting criteria, these accidents caused damage to railroad property exceeding a threshold of \$4,900 in 1985 and 1986, and \$5,200 in 1987. Incidents that caused an injury to persons, but did not cause damage exceeding the threshold are not included.

Accidents have been divided into those occurring to intercity passenger (Amtrak) trains and to commuter trains. In the U.S., most intercity passenger trains share tracks with freight trains, and during the period analyzed almost all were locomotive hauled. Commuter trains are less likely to share track with freight trains, and are often multiple unit trains or push-pull operations with a cab car at one end and a locomotive at the other.

Examples of 21 of the 44 scenarios defined in Tables 2-1 to 2-4 have been identified in this three-year period. Most of those scenarios not represented in the three-year period involve speeds or other conditions not found in conventional railroad operations, are of very rare occurrence, or are unlikely to be captured under the FRA reporting criteria, as follows.

- High speed collisions between similar trains, scenarios 1.1 c and d, 1.2 c and d and 1.3 c and d. Such collisions are possible, but are of very rare occurrence and would inevitably be very serious. Past accident experience suggests that severe railroad accidents occur in the US about once in ten years. The one high speed collision in the review period (Chase, Maryland, in December 1987) has been classified as a passenger-freight collision, scenario 3.3 a.



**Table 2-5. Summary of Passenger Train Accidents on Main Track 1985-1987**

No. Scenario Description	Accidents			Casualties(4)		
	Intercity	Commuter	Total	Killed	Injured	
<b>1 Collisions with Similar Trains</b>						
1.2a Low speed loco-cab	0	1	1	1	0	1
1.2b Intermediate speed loco-cab	0	1	1	1	0	9
1.3a Low speed cab to cab	0	1	1	1	0	0
1.3b Intermediate speed cab to cab	0	8	8	8	3	190
<b>2 Collisions with Obstructions</b>						
2.1a Grade crossing loco to truck	27	4	31	31	0	33
2.1b Grade crossing cab to truck	0	7	7	7	0	59
2.1c Grade crossing loco to auto	6	6	12	12	0	29
2.1d Grade crossing cab to auto	0	9	9	9	0	1
- Grade crossing loco to undefined vehicle	10	7	17	17	2	12
- Grade crossing cab to undefined vehicle						
2.4a Loco to maintenance equipment	0	2	2	2	0	1
2.4b Cab to maintenance equipment	2	0	2	2	0	0
2.5a Loco to debris	0	1	1	1	0	0
2.5b Cab to debris	8	2	10	10	0	1
2.6b Cab to guideway	0	5	5	5	0	0
2.7a Loco to rail vehicle	0	3	3	3	0	0
2.7b Cab to rail vehicle	2	1	3	3	0	4
2.7c Loco to highway vehicle	0	1	1	1	0	0
2.7d Cab to highway vehicle	5	3	8	8	0	4
		0	2	2	0	0
<b>Collisions with Dissimilar Train Types</b>						
3.3a Loco to freight	1 <sup>1</sup>	1 <sup>2</sup>	2	2	16	244
3.3b Cab to freight	0	1 <sup>2</sup>	1	1	1	2
<b>4 Single Train Events</b>						
4.2a Derailment, loco leading	26	12 <sup>3</sup>	38	38	1	240
4.2b Derailment, cab leading	0	6 <sup>3</sup>	6	6	0	1
<b>Overall Totals</b>	87	84	171	171	23	831
<b>Other Reportable Accidents</b>						
Fires	5	11	16	16	0	0
Catenary/Pantograph failures	23	35	58	58	0	0

<sup>1</sup>Chase, Maryland, December 1987 - 16 fatalities, 176 injuries.

<sup>2</sup>All at intermediate speeds - below 50 km/h (30 mph).

<sup>3</sup>Most commuter derailments were low/intermediate speed. Only one injury among all 18 accidents.

<sup>4</sup>Casualties are to train occupants and railroad employees only. Casualties to highway vehicle occupants in at-grade highway crossing accidents are not included in this tabulation.

- Scenarios 2.2 a and b, and 2.3 a and b, which are collisions with persons or animals on the guideway. These accidents are unlikely to cause damage exceeding the FRA reporting threshold, but are known to occur. Such collisions do not pose a threat of serious damage to conventional U.S. trains.
- Scenarios 2.8 and 2.9 (gunfire and objects dropped in front of trains) are known to occur, but since the damage is usually confined to one window the cost of damage does not exceed the reporting threshold.
- Scenarios 4.1 a and b (loss of levitation or guidance) apply only to maglev systems.
- Scenarios 3.1 a and b, and 3.2 a and b, collisions between high-speed trains and conventional passenger trains do not apply, as only conventional trains operate currently in the U.S.
- Scenarios 4.3 a and b (derailment and collision with adjacent structures) are surprisingly absent in the sense that collisions of this type are clearly possible and might be expected. However, it is likely that they occurred, but were not identified in the available accident data. The FRA reports only contain a short narrative, which might not mention that a post-derailment collision occurred, and post-derailment collision is not identified as a specific accident type on the reporting form.
- The remaining three scenarios are low and intermediate speed collisions between power vehicles or locomotives (1.1 a and b), and a collision between a locomotive and end of guideway (2.6 a). The absence of collisions between locomotives - when both are in passenger trains - is not surprising. This scenario occurs only when trains are given permission to operate toward each other on the same track - a grave failure in railroad operations. However, there are examples of these scenarios among the serious accidents described in Section 2.4.2 (review of serious railroad accidents in the U.S.).

The most common type of collision, although not the most serious, is the at-grade highway crossing collision. These collisions account for nearly half of all the reported accidents listed (78 out of 171), two of 23 fatalities, and 16 percent of injuries. These totals only cover at-grade highway crossing collisions that produced damage exceeding the reporting thresholds. There are many more that did not produce such damage. The high frequency of occurrence of grade crossing accidents in the U.S. is clearly an important factor to be taken into account when planning wheel-on-rail high-speed train operations over existing track.

Similar to at-grade highway crossing collisions with regard to consequences are collisions with highway vehicles at locations other than at-grade highway crossings (Scenarios 2.7 c and d) of which 10 occurred in the period analyzed. These occur when a highway vehicle has been left foul of railroad tracks, for example in a parking area. Since most railroad tracks in the U.S. are unfenced, there are many locations where it is easy to get a highway vehicle close to railroad tracks.

Eleven collisions occurred between similar trains, all commuter trains at low or intermediate speeds (below 50 km/h, 30 mph). Of these, nine out of eleven were between multiple unit trains.

These eleven collisions resulted in 24 percent of all injuries reported but no fatalities. This result indicates the potential for significant numbers of injuries at these low speeds.

Three collisions occurred between passenger and freight trains. One is the very severe accident at Chase, Maryland, in December 1987. A consist of three freight locomotives failed to observe signals and traveled through a switch from a secondary track onto a main track where it was hit by a passenger train travelling at approximately 105 mph. This accident resulted in 16 fatalities and 176 injuries. The other two occasions where a passenger train collided with a freight train were both situations where a freight train had entered a siding but had failed to fully clear the main track. The FRA report on one of these accidents indicated a collision speed of 24 km/h (15 mph), and an estimate of 68 injuries. This same accident, however, was the subject of an NTSB inquiry (Number 18 in Table A-1) which estimated that the collision speed was about 40 km/h (25 mph) and 153 injuries were reported. This comparison suggests that caution should be used in interpreting FRA accident data, in particular care should be exercised not to place too much weight on exact numerical values.

Very few casualties were produced by collisions with miscellaneous obstructions. A total of nine injuries resulted from 25 such collisions. The obstructions included maintenance of way equipment, rail vehicles partially fouling the track, bumping posts, and debris. In two cases the 'debris' was ice and snow.

The final category is a single train derailment (types 4.2 a and b). There were 44 such events resulting in 241 injuries and one fatality. Track defects were the most common cause (24), followed by vehicle defects (12), human error (6), and vandalism (3).

It is clear from this sample of accident data that train-to-train collisions are by far the most serious accidents. Although relatively few at 14 out of 171 reported collision and derailment accidents, they caused nearly all the fatalities (20 out of 23) and more than half the injuries (446 out of 831). Therefore, a strong focus on the avoidance and survivability of collisions between trains seems to be highly appropriate in any safety assessment effort.

#### **2.4.2 Review of Serious Railroad Accidents in the U.S.**

Serious transportation accidents in all modes in the U.S. are investigated by the National Transportation Safety Board (NTSB). Most passenger train accidents in which there are fatalities, a large number of injuries, or show evidence of a serious breach of good safety practice are the subject of such investigations. Approximately 20 years of NTSB reports on passenger train accidents from 1969-1989 have been reviewed, yielding the tabulations of accident data for a total of 35 accidents provided in Appendix A, Tables A-1 and A-2. All passenger train collisions or derailments that were subject to an NTSB investigation are included. A long review period is required because serious accidents and thus NTSB investigations are rare events. Taking too short a period is likely to lead to unreliable conclusions regarding the prevalence of different kinds of accidents.

Table A-1 lists a total of 19 collisions, of which 11 resulted in fatalities, and two were very serious with more than 10 fatalities.

The table documents train speeds and weights, damage to the vehicles, and the number of casualties. An attempt is also made to calculate approximate energy dissipation during the collision and the magnitude of resulting acceleration pulse. The calculation is performed by assuming that both trains are rigid bodies, except for crushing during impact, and that momentum is conserved during impact. This enables energy dissipated during the impact to be calculated from the difference in total kinetic energy before and after impact. Assuming this energy is dissipated in longitudinal crushing of the cars, an estimate is made of the longitudinal crush force and hence the impact acceleration of both trains. A more rigorous discussion of collision analysis is provided in Volume 3, Chapter 2 of this report. This procedure probably gives reasonable results for short trains that stay in line. For long trains with a lot of aggregate slack in the couplers (such as most freight trains), and high energy collisions where there is extensive jackknifing, vehicle rollover and crushing, the situation is too complex for such simple estimates to be other than very approximate.

With these reservations, the results suggest that the acceleration impulse during impact is typically between 1.0 and 4.0 g, and the amount of crushing suggests acceleration pulse durations on the order of 0.5 to 1.5 seconds. A "ride-down" phase takes place after impact, with energy being dissipated by the derailed vehicles sliding over the ground. The accelerations during this phase are below 1.0 g, and typically in the range 0.05-0.5 g.

The two collisions that caused more than 10 fatalities were:

- An October 30, 1972, collision between two electric multiple unit trains on the Illinois Central Railroad commuter line into Chicago (number 2 in Table A-1). The colliding units were of totally different designs. One was an old heavyweight single level car, and the other a relatively new gallery type bi-level car called the Highliner. The Highliner lacked strong collision posts and was overridden at impact. The high occupancy of the car led to 45 fatalities. Further discussion of the issues associated with this accident concerning the structural design of the car is provided in Volume 3 of this report. Essentially, the mismatch of vehicle types was the principal cause of override and the large number of casualties. The collision itself was not particularly severe in terms of speed, train weight, and total energy dissipated.
- A January 4, 1987, collision between three stationary locomotives and an Amtrak passenger train at Chase, Maryland (number 19 in Table A-1). The Amtrak train, consisting of two locomotives and 12 cars, was travelling at about 105 mph at impact. This was a very high energy collision: the kinetic energy of the train before impact was 874 MJ ( $645 \times 10^6$  ft-lbf) and the energy dissipated at impact is very roughly estimated to be 499 MJ ( $368 \times 10^2$  ft-lbf), over ten times that in the Chicago accident described above. Both Amtrak locomotives were destroyed, and the first three cars jackknifed round to 90° relative to the direction of travel and rolled over. The first two cars were severely crushed. Fortunately, the first car was unoccupied. Most of the fatalities were in the second car. There would have likely been many more casualties had the first car been occupied.

Other than these two accidents, no collision among those reviewed resulted in more than 10 fatalities. However, as with the two very severe accidents, fatalities appear to be associated with

severe whole-body crushing rather than as a result of an acceleration pulse. Crushing of the operator's cab appears to be a significant cause of fatalities in these less severe accidents.

Longitudinal acceleration at the time of impact and during 'ride-down' produces large numbers of minor to moderate injuries due to vehicle occupants being thrown against interior fittings and surfaces, and damage to interior fittings such as seats. Current rail vehicle equipment attachment requirements have developed from the examination of the accidents as discussed in this section. Note that many of the vehicles involved in the accidents listed in Tables A-1 and A-2 are built to older designs that would not meet current requirements.

In summary, the empirical data suggests that collision consequences for rail vehicles designed to current U.S. structural requirements can roughly be linked to the energy dissipated at collision impact:

Below 10 MJ ( $7 \times 10^6$  ft-lbf)

- Minor damage
- Minor injuries only

10-60 MJ ( $7-44 \times 10^6$  ft-lbf)

- Crushing of vehicle ends
- Fatalities among control cab occupants possible
- Vehicles stay upright and in line
- Numerous minor/moderate injuries

60-120 MJ ( $44-88 \times 10^6$  ft-lbf)

- Severe damage to colliding vehicles at ends of trains
- Significant risk of fatalities among end vehicle occupants
- Numerous minor/moderate injuries

Over 120 MJ ( $88 \times 10^6$  ft-lbf)

- Severe damage to two or more vehicles in each train possible
- Significant risk of high number of fatalities
- Numerous minor/moderate injuries

The analysis of derailments is given in Table A-2. As with collisions, fatalities appear to be associated with gross crushing of car bodies. The exceptions are two accidents at the beginning of the review period (numbers 2 and 3) where there were a number of fatalities reported to be due to ejection from windows. Current glazing and window size requirements, however, appear to have reduced such fatalities in recent years.

Most of the derailments involved heavy trains (over 900 tonnes [1000 tons]) travelling at 100-150 km/h (60-90 mph). The total energy to be dissipated is high - between 300 MJ and 1100 MJ ( $220-800 \times 10^6$  ft-lbf). Depending on the terrain at the derailment site, vehicles can roll over, fall down embankments, jackknife, or collide with lineside structures. The worst recent derailment accident, to Amtrak's Montrealer in Vermont (July 7, 1984), was caused by a washout in a severe storm. One car fell into space left by a washed-out culvert and was badly crushed by following vehicles, leading to five fatalities. There is no clear empirical relationship

between the total energy dissipated and the severity of damage and casualties, which appear to depend on the circumstances of the individual accident.

As with collisions, the deceleration experienced by otherwise undamaged cars (in the range 0.05 to 1.0 g) appears to lead to numerous minor and moderate injuries, but no fatalities.

### 2.4.3 Foreign Accidents

This section describes a small number of particularly severe or significant accidents in France and the U.K. They are significant either because of their severity, because they were instrumental in drawing attention to particular hazards, or because they resulted in the imposition of new safety requirements.

- Voiron, September 1988. A Paris-Southeast Train a Grand Vitesse (TGV) train-set struck an 80 tonne press on a highway trailer on a grade crossing at 110 km/h (68 mph). The train-set consisted of a lead power car, eight articulated passenger cars, and a second power car at the rear. There was considerable crushing of the lead power car, but the train stayed upright and in-line, and there was no serious damage to the passenger cars. This accident caused two fatalities, one of which was the train operator, and 60 injuries. This is the most significant example of a collision involving a high-speed train, albeit at relatively low speed. It is estimated that the crushable nose of the TGV absorbed about 10 percent of the impact energy of about 30 MJ ( $22 \times 10^2$  ft-lbf) (Reference 3). This incident has been selected by French National Railways (SNCF) as a reference case for improved crashworthiness design of future TGV models. The first design to the new requirements will be the aluminum-bodied double-deck TGV, currently in prototype test. Maximum use is being made of crushable zones at the ends of vehicles (in the power car nose and body behind the cab, and in the baggage areas and vestibules of the passenger vehicles). These zones are designed to have a lower compressive strength than the operator's cab and passenger seating areas. A crash test is planned at the end of 1992 to validate the design analysis.

A somewhat similar accident to that at Voiron occurred in October 1991, involving a collision between a gas turbine-powered train-set (similar to those operated by Amtrak in the U.S.) and a tractor-trailer immobilized on an at-grade highway crossing. This accident also resulted in two fatalities: the operator and conductor of the train (Reference 4).

- Paris, Gare de Lyon, June 1988. A crowded commuter multiple-unit train crashed into the end of the tracks in this terminal station, causing 56 fatalities. The train had experienced a stop initiated by a passenger emergency alarm earlier in the journey, and the train crew's attempts to address the problem led to the inadvertent isolation of the brakes on a large part of the train. Thus, the train was unable to stop on approaching the terminal. As well as highlighting the importance of a proper pre-departure brake test routine, it was sufficiently serious to cause a wide-ranging review of safety on SNCF (Reference 5). A primary outcome of the review was the acceleration of plans to apply Automatic Train Protection (ATP) to all main lines. A number of equipment-specific modifications were made, and steps taken to improve train-crew training.

These safety improvements were given further impetus by a serious accident at Melun (near Paris) in October 1991. A head-on collision at a relative speed of about 100 km/h (62 mph) between locomotive-hauled freight and passenger trains resulted in 16 fatalities and 53 injuries. The cause of the accident was the failure of the operator of the freight train to observe a stop signal. The leading car of the passenger train overrode the locomotive and was totally destroyed, focussing attention on vehicle body structure performance in collisions (Reference 6).

- Hixon, U.K., 1970. This accident was similar to the TGV accident at Voiron: a locomotive hauled passenger train struck a 126 tonne (130 ton) transformer on a slow-moving highway trailer at an at-grade highway crossing at about 130 km/h (80 mph). There were 11 fatalities and 42 injuries. An important outcome of this accident was a new regulation for at-grade highway crossing safety precautions. Operators of oversize or overweight highway vehicles must get positive permission to proceed via telephone at each crossing, full barriers replaced half barriers at many locations, closed circuit television was installed for crossing surveillance, and changes were made to the timing of automatic crossing gates.
- Polmont, U.K., July 1984. A six-car train driven from a cab car and propelled by a locomotive in the rear struck a cow at about 137 km/h (85 mph) and derailed. There were 13 fatalities. The accident was unusual in that comparable animal collisions are fairly common and do not normally cause serious derailments. This particular result seems to have been caused by a combination of a very light cab car (weighing about 34 tonnes (37.5 tons), and relatively high speed. The first two vehicles of the train jackknifed and rolled over. The fatalities were mainly caused by ejection from windows (Reference 7).

This accident led to a broad re-examination of the safety of cab-car operations at higher speeds. Cab cars now must have a minimum weight of 48 tonnes (53 tons), and be equipped with a 'cow-catcher' capable of resisting an impact load of 60 tonnes (66 tons). At speeds exceeding 160 km/h (100 mph), cab cars cannot have passenger seating. British Rail's IC225, which is designed for push-pull operation to 225 km/h (140 mph), is equipped with a cab-baggage car.

- Clapham, U.K., December 1988. In this collision, a 12-car electric multiple unit train hit the rear of a similar, stationary 12-car train at about 65 km/h (40 mph). The two leading cars of the following train were very seriously damaged. There were 35 fatalities among passengers and crew. The accident took place during the morning rush hour and both trains were well loaded. The impact energy of this collision was 39 MJ ( $29 \times 10^6$  ft-lbf). The reason for the high number of fatalities was the fact that both colliding vehicles were passenger cars with most seats occupied, and the cars were of an old structural design that would not meet current UIC requirements. The direct cause of the accident was the display of a false "all clear" signal to the following train. The interlocking system had been left in an unsafe condition by a technician working on signal modifications the previous day. Subsequent inquiry revealed a serious lack of supervision and quality control in signal system maintenance (References 8 and 9).

This accident resulted in a decision to apply a modern ATP systems on all major routes in the U.K. Although ATP would not have prevented this particular accident, it was seen as a way of generally reducing collision risks. Signal "wrong-side" (i.e., unsafe) failures were to be reported, and ongoing investigations of rolling stock structural integrity to be accelerated.

## **2.5 CAUSES AND CONSEQUENCES OF COLLISIONS AND OTHER ACCIDENTS**

The causes and consequences associated with each type of HSGGT collision and accident are described in this section. To a large extent, the information on causes and consequences is derived from the empirical analysis of past accidents provided in Section 2.4.

The accidents will be discussed in four groups.

1. Collisions between trains or vehicles on the same guideway, including both similar and dissimilar types of trains. End of guideway collisions have similar causes and also are included under this heading.
2. Grade crossing collisions (wheel-on-rail HSGGT systems only)
3. Collisions with obstructions on or fouling the guideway
4. Single train or vehicle events

Also, for the purpose of this discussion, accident consequences have been divided into four severity levels as follows:

1. Minor severity: localized vehicle damage only and potential for a small number (fewer than ten) minor injuries. Severe injuries or fatalities may occur only under very unusual circumstances.
2. Moderate severity: significant vehicle damage, e.g., crushing of end structure. Potential for a large number of minor injuries, but a small number of severe injuries (fewer than ten). One or two fatalities may occur.
3. High severity: major damage to impacting vehicle or vehicles such as crushing or override. Potential for a large number of minor injuries, several serious injuries, and up to ten fatalities.
4. Very high severity: major damage to two or more vehicles in a train - severe crushing, jackknifing or similar behavior. Potential for a large number of severe injuries and in excess of ten fatalities.

Causes and consequences are tabulated in Table 2-6 and discussed in the following sections.



**Table 2-6. Accident Causes and Consequences**

Scenario(s)	Causes	Consequence Severity
1. 1a, 1.2a, 1.3a Low speed train-to-train collisions	Human error. Operating rule deficiencies. Braking system defects. Signal system defects.	Usually minor, occasionally moderate.
1. 1b, 1.2b, 1.3b Intermediate speed train-to-train collisions	Same as low-speed collisions.	Moderate, occasionally severe.
1. 1.1c, 1.2c, 1.3c, 1. d, 1.2d 1.3d High-speed train-to-train collisions.	Same as low-speed collisions.	Severe or very severe.
2. 1a to d At-grade highway crossing collision.	Highway vehicle operator error (usual). Stalled highway vehicles. Signal malfunction (rare)	Minor for autos and most trucks. Moderate or occasionally severe with trucks and overweight highway vehicles.
2.2a, 2.2b Animal on guideway	Lack of adequate fencing.	Usually minor, moderate/severe on rare occasions.
2.3a, 2.3b Person on guideway.	Lack of fencing to prevent trespass. Lack of adequate procedures/training for work on or near guideway.	Negligible for vehicle. Severe, fatal for person.
2.4a, 2.4b Maintenance equipment collision.	Lack of adequate procedures for work on guideway. Inability to detect presence of equipment.	Usually minor or moderate. Severe if equipment large and speeds high.
2.5a, 2.5b Collision with rocks and debris.	Lack of adequate protective barriers or obstruction detection systems.	Usually minor, occasionally moderate.
2.6a, 2.6b Collision with end of guideway.	Same as low-speed train-to-train collision.	Dependent on speed. Similar to train-to-train collisions.
2.7a, 2.7b Rail vehicle encroachment.	Failure to stop vehicle in clear. Accident on adjacent guideway shifted load.	Minor to severe, dependent on HSGGT speed, amount of encroachment.
2.8 Gunfire	Careless or malicious behavior by public.	Minor local damage, no casualties.
2.9 Object dropped in front of train, or bird strike.	Vandalism, item detached from train on adjacent guideway.	Usually minor local damage, no casualties.
3.1, 3.2, 3.3 Collision between dissimilar trains.	Same as for collision in groups 1.1, 1.2, 1.3.	Dependent on speeds, as for collisions in groups 1.1, 1.2, 1.3.
4.1-4.3 Single train events.	Vehicle failure, guideway failure, human error (e.g., over speed).	Dependent on speed, roughly as follows: Under 10 km/h: minor 10-50 km/h: moderate 50-150 km/h: moderate or severe Over 150 km/h: severe

### **2.5.1 Causes and Consequences of Collisions Between Vehicles or Trains on the Same Guideway**

All collisions between trains on the same guideway are a result of human error or a technical defect in one or more of the following HSGGT features and equipment:

- Signal and train control systems
- Brake systems
- Operating staff qualifications and training
- Operating rules and practices

These causes are discussed in more detail below:

- Human error - in the failure of the train operator to obey signals and other movement instructions, or the issuance of incorrect instructions by a dispatcher - has been the leading cause of serious collision accidents on traditional railroad systems. Although great care is taken to ensure that signal systems are highly reliable and very unlikely to display an incorrect signal that is less restrictive than the correct signal, obedience to signals and operating instructions has always been dependent on the human operator. The two most serious railroad accidents in the last 20 years in the U.S. were both caused by operator error. However, it is highly likely that an HSGGT system will be equipped with an ATP system for high-speed operations, leading to a large reduction in the risk of a human error accident at high-speed. In this case, human error collisions will be most common at lower speeds, where ATP systems are less likely to be used.

A failure to follow correct maintenance and inspection procedures for vehicles, guideway, or signal and control systems also can be regarded as human error. Such failures are a contributing cause in accidents where the immediate cause may be equipment failure.

- Lack of appropriate guidance for a given situation in the operating rules and instructions. This is a rare cause but is conceptually possible, for example in an emergency situation brought about by an unusual sequence of events. It also is possible on new technology HSGGT systems, where there is limited experience with new operating rules. An important area for attention to operating rules, and where deficiencies sometimes occur, is in procedures to prevent conflicts between people and equipment engaged in guideway maintenance and inspection, and normal passenger service operations.
- A fault in the braking system impairing the ability of a train to stop as required by signal indications or train control instructions. The most common example of a braking fault is a train departing on a leg of a journey with inoperative brakes after a failure to perform proper pre-departure brake tests. The serious accident at the Gare de Lyon in Paris (see Section 2.4.3) was due to this cause. Actual mechanical or electrical failures in the braking system historically have been very rare. However, care must be taken in new HSGGT systems that may rely totally on electric or electronic control of brakes (braking-by-wire) to achieve a safety performance equivalent to the historic safety performance of pneumatically controlled brake systems.

- A malfunction of the signal system resulting in a false proceed signal. Such incidents are rare, given the efforts of signal engineers to design their systems to be intrinsically fail-safe, or to provide adequate redundancy. However, they do occur, as a result of errors made during design, installation and maintenance, or a failure of the system to detect the presence of a train. The results can be disastrous, as at Clapham in the U.K. in late 1988 (see Section 2.4.3). Human error in the form of a failure to follow proper inspection and maintenance procedures is frequently a contributing cause.
- A wrongly set switch or turnout that can divert a train onto the wrong track, leading to a collision. This type of accident is most likely to occur at locations with manually turnout operated switches not interlocked with the signalling system. Thus, the primary cause of such accidents is human error. Switching and errors have caused serious collisions and derailments of passenger trains operating over freight railroad track in the U.S. (see Section 2.4.2 and the Appendix). Such collisions are far less likely at turnouts integrated into an interlocking system, where an accident would not be possible without a signal failure.

The consequences of collisions have been discussed extensively in Section 2.4. The severity of damage, and thus the potential for causing casualties among vehicle occupants, appears to be a function of energy dissipated in the impact.

Impact energy can be estimated from the kinetic energy of the colliding trains or vehicles before and after the collisions. The assumption of conservation of momentum is used to calculate the velocity of the combined trains or train and obstruction after the impact. Very approximate results of empirical impact energy calculations and corresponding damage severity are given in Table 2-7 for conventional U.S. and European trains. The results are based on analysis of U.S. accidents as given in Table A-1 in the Appendix, and of the European accidents described above.

Almost all the U.S. vehicles in the accidents reviewed were designed to current FRA and Association of American Railroads (AAR) structural requirements, and the results are representative of the performance of such vehicles in collisions. The modern European vehicles are those that meet or exceed the current requirements of UIC Code 566, Load Cases. As would be expected, the impact energy needed to produce a given level of damage is lower for European vehicles than for U.S. vehicles. Since European trains are typically of lower weight, however, collision energy is also lower at a given collision speed. Older European vehicles, such as those involved in the Clapham accident in the U.K., do not necessarily meet current UIC requirements and still lower collision energies are required to produce a given level of damage. In particular, older vehicles may lack vertical strength or override protection at the inter-vehicle coupling and may have very weak structure above the underframe.

It should be emphasized that the numbers in Table 2-7 should only be used as a very rough guide. The circumstances of individual collisions and the detailed design of the vehicles involved play a large part in determining the outcome of a collision. Even taking into account this variability, however, the results indicate that with current technology, railroad trains cannot survive collisions at speeds exceeding 130-160 km/h (80-100 mph) without severe damage and a large number of casualties. It is also clear that the results of a collision at high speed, over 200 km/h (125 mph), would result in severe damage to several vehicles or vehicle sections, and multiple fatalities. These results suggest that it is not possible to ensure survivability in high-

**Table 2-7. Estimated Relationship Between Collision Energy and Damage Severity in Train Collisions**

<b>Accident Damage Severity</b>		<b><u>Collision Energy</u></b> <b>MJ (10<sup>6</sup> ft-lbf)</b>		
		<b>U.S. Conventional European</b>	<b>Modern European</b>	<b>Older</b>
<b>Minor:</b>	Local damage only	< 10 (7)	< 5 (3.5)	-
<b>Moderate:</b>	Crushing of vehicle ends	10-60 (7-44)	5-35 (3.5-25)	<20 (15)
<b>High:</b>	Major damage to impacting vehicles	60-120 (44-88)	35-70 (25-50)	20-40 (15-30)
<b>Very High:</b>	Major damage to two or more vehicles in a train; crushing override, jackknifing	> 120 (88)	> 70 (50)	> 40 (30)

speed collisions with any reasonable vehicle design philosophy, and the safety emphasis in HSGGT systems must be on the avoidance of such accidents.

### **2.5.2 Causes and Consequences of At-Grade Highway Crossing Collisions**

At-grade highway crossing collisions are almost invariably caused by human error on the part of the operator of the highway vehicle, or a highway vehicle becoming immobilized on a crossing for some reason. Grounding of long, low clearance vehicles on an uneven road surface at the crossing is one reason for immobilized vehicles. In a few instances, a crossing warning system may fail to operate. The failure of track circuits to detect the presence of a train is one mode of failure.

The severity of consequences for the train depends primarily on the weight of the highway vehicle involved in the collision. Collisions with autos rarely lead to a serious accident, although they can cause derailment. Collisions with trucks can be more serious, but most still appear to be in the low or moderate severity categories as defined in Section 2.5.1.

When more serious consequences occur, they appear to be the result of unfavorable characteristics of the truck's lading or because the highway vehicle is unusually heavy. Examples include the outbreak of fire following collisions with trucks carrying flammable liquids, and penetration of the rail vehicle by heavy objects on the truck. Consequences in the moderate to severe categories have occurred following collisions with unusually heavy vehicles, such as the Hixon, U.K., and Voiron, France, collisions described in Section 2.4.3.

### **2.5.3 Causes and Consequences of Collision with Obstructions on or Fouling the Guideway**

The causes of such obstructions are diverse and normally related to the nature of the obstruction. The severity of consequences is largely a function of the mass and density of the obstruction. Collision with large objects, that weigh more than 10 percent of the HSGGT vehicle have the potential of causing a derailment or significant structural damage. Collisions with smaller objects can cause local damage to the HSGGT vehicle, but would not normally lead to more serious consequences unless the damage occurred in a particularly safety-critical area.

Comments on individual obstruction collision types are as follows:

- Animals on the guideway (Scenario 2.2) are invariably a result of the lack of fencing, or failing to keep fences in good repair. (This scenario only includes terrestrial animals. Bird strikes are covered by Scenario 2.9.) Consequences are usually minor, but can occasionally be more serious, as at Polmont (U.K.) as described in Section 2.4.3.
- A collision with a person on the guideway (Scenario 2.3) can be a result of:
  - Lack of fencing, or a failure to keep fencing in good repair, thus allowing trespassers to gain access to the guideway.
  - Failure by system employees or contractor personnel to observe operating rules and instructions pertaining to working on or near the guideway.

Consequences are serious or fatal for the person, and minor for the vehicle.

- A collision with inspection or maintenance equipment on the guideway (Scenario 2.4) could be due to:
  - Failure on the part of persons responsible for the equipment to observe the relevant operating rules and instructions.
  - Deficiencies in the operating rules and instructions.
  - Failure of the signal and train control system to detect the presence of the equipment automatically, where this would normally be expected.

Depending on the mass of the equipment, the consequences can be at any level of severity. The mass of large on-guideway maintenance or inspection equipment can be similar to that of a passenger-carrying vehicle. Thus, the potential exists for moderate to severe consequences as defined at the beginning of this section.

- A collision with rocks or debris (Scenario 2.5) is a result of inadequate right-of-way security. Deficiencies could include a lack of adequate fencing to keep out vandals, a lack of other forms of safety barriers such as a trough to catch debris that may fall from the sides of a cutting, or lack of effective devices to detect obstructions. Since the obstruction is usually a relatively small object, impact damage on the vehicle is likely to be minor, provided local structures have been designed to sustain such impacts. A risk exists of damage to a safety-critical component in the vehicle guidance, support, or suspension systems caused by an object becoming trapped under the vehicle, or causing a derailment in the case of a wheel-rail vehicle.
- Collisions with other HSGGT or rail vehicles encroaching from an adjacent track (Scenario 2.7) are caused by human error, such as a failure to secure parking brakes or a failure to ensure the vehicle or train is in the clear when parked. Other causes can include a shifted load on a freight car, or an accident on an adjacent track or guideway resulting in vehicles fouling the high-speed guideway. These circumstances can arise both in a shared corridor, where the HSGGT guideway is parallel to a conventional railroad, or in wheel-on-rail HSGGT operations over existing tracks.

The severity of consequences can range from minor to severe, depending on the mass and position of the obstructing vehicle. At worst, this kind of collision approaches in severity a collision with another vehicle or train on the same guideway.

- The gunfire scenario (2.8) results from the malicious or careless use of a weapon within range of the guideway. Since such action normally takes place off HSGGT property, there is little the HSGGT operator can do to prevent such incidents. Fortunately, the consequences are minor, provided the vehicles or trains are equipped with impact resistant windows and outer sheeting. Bullets do not penetrate such protection, and only localized damage results.

- A collision due to an overrun at the end of the guideway (Scenario 2.6) has very similar causes and consequences to the collision-between-trains scenarios discussed in Section 2.5.1.
- Objects that drop or fall in front of train (Scenario 2.9), or become detached from trains on adjacent guideways are caused by a lack of adequate precautions against vandalism (fencing and other barriers) especially at overbridges, and lack of adequate maintenance and inspection of other trains and vehicles operating on guideways adjacent to the HSGGT guideway. This class of collision also includes impacts with birds.

The consequences of collisions with dropped or flying objects are usually minor. Local damage occurs to forward facing structures and windows. Such structures and windows are normally designed so that the objects or birds do not penetrate and injure vehicle occupants, often vehicle crew-members in a cab.

#### **2.5.4 Causes and Consequences of Single Train or Vehicle Accidents**

There are three categories of causes of single vehicle accidents, defined as those not involving another train, vehicle, or obstruction on the guideway. These are:

- A failure of a critical vehicle system or structural component. This leads to a loss of proper support (by wheels or magnetic levitation) and/or of guidance. Examples of failures include the failure of a wheel, axle-bearing, or suspension component in a wheel-on-rail vehicle, or a malfunction in a maglev support or guidance magnet. A brake system failure could lead to an overspeed accident, for example, on a sharp curve.
- A failure of a guideway system or structural element, or guideway geometrical deviations higher than can be tolerated by the vehicle. Examples include broken rails and track buckling events for wheel-on-rail systems, and a severe geometry deviation or partial detachment of guideway-mounted equipment on a maglev guideway that causes impact between a support or guidance magnet and the guideway.
- Human error on the part of vehicle or train operators, or other operating and maintenance staff. Examples include operating a train at excessive speed for curvature and guideway conditions, a wrongly set manually controlled turnout, and maintenance personnel leaving the vehicle or guideway in an unsafe condition prior to operation. Operator errors are most likely on an HSGGT system when it is being operated at low speed under manual control, or when a wheel-on-rail HSGGT train is being operated over existing tracks under conventional train control practices.

The consequences of single vehicle or train accidents are dependent on speed at the time of the event. However, because the severe impacts of collisions are not normally present, the severity of damage and incidence of casualties are typically less in a single train accident than in a train-to-train collision at the same speed. Even at the higher speeds operated by conventional wheel-on-rail trains, very severe consequences usually are avoided in single train accidents when modern equipment is used. However, more severe consequences follow when the accident involves a collision with a building or structure (such as a bridge abutment) after the initial loss of support

or guidance. At worst, such accidents can be as serious as train-to-train or vehicle-to-vehicle accidents.



### **3. REVIEW OF FOREIGN HIGH SPEED GUIDED GROUND TRANSPORTATION SAFETY REGULATIONS**

#### **3.1 INTRODUCTION**

This chapter provides a review of foreign high speed guided ground transportation safety requirements as they relate to collision avoidance and accident survivability in the accident scenarios developed in Chapter 2. The review primarily covers wheel-on-rail systems that are currently in revenue-earning service, such as the French TGV, German ICE and Japanese Shinkansen. Rules, regulations, standards, and practices followed by the foreign HSGGT systems are documented and referenced to the accident scenarios discussed in Chapter 2. Safety requirements applicable to magnetic levitation systems in Germany have been the subject of concurrent efforts by VNTSC (Reference 9). The Japanese superconducting electrodynamic maglev system is not included, since little information on safety requirements is available. Commercial operation of this technology is at least a decade in the future.

Foreign HSGGT safety requirements (regulations, codes, standards, and practices) have been grouped into several categories for the purpose of this review. The categories are described in the paragraphs below, together with the relationship between each category and the accident scenarios described in Chapter 2. The relationships between the safety requirements categories and accident scenarios are summarized in Table 3-1.

##### Collision Avoidance

Collision avoidance safety requirement categories cover all requirements that play a part in preventing the occurrence of a collision or accident. This includes requirements for signal and train control systems to maintain adequate separation between trains, means for preventing guideway obstructions, at-grade highway crossing warning and protection systems to reduce the risk of crossing collisions, and brake system requirements to ensure that vehicles can reduce speed when needed.

Individual categories are described below:

#### **1. Signal and Train Control Systems**

The primary function of signal and train control systems are to ensure that trains or vehicles are only given permission to proceed when the guideway is in operable condition, switches are properly set, and a safe distance can be maintained relative from other vehicles. A second function is to ensure that the vehicle does not exceed a safe speed. Signal and train control safety requirements ensure that these functions can be provided with a very low incidence of unsafe failures. Signal and train control system capabilities affect the incidence of all collisions in Group 1 (Table 2-1) (collisions between similar HSGGT trains or vehicles on the same guideway), and Group 3 (Table 2-3) (collisions between dissimilar trains or vehicles on the same guideway).

**Table 3-1. Relationship Between Safety Requirements Categories and Collision Scenarios**

Safety Requirements				Collision or Scenario Group (Tables 2.1-2.4) and Scenarios	
Overall Function	Reference	Category	Functions	Reference	Description
Collision Avoidance	1	Signal and train control system	Monitor route integrity and permit vehicle movement only when safe. Maintain safe separation between vehicles on same guideway. Enforce speed limits.	Group 1 Group 2 2.4 2.6 Group 3	Collisions between similar trains (all scenarios) Collisions with guideway obstructions Maintenance equipment Overrun at guideway end Collisions between dissimilar trains (all scenarios)
	2	Right-of-way security (excl. grade crossings)	Prevent debris, animals, people, vehicles from intruding into clearance required by operating vehicles.	Group 2 2.2 2.3 2.5 2.7 2.9	Collisions with obstructions on guideway Animal Person Rocks or debris Vehicle encroachment on guideway Object dropped in front of vehicle
	3	At-grade highway crossing warning and protection systems	Reduce incidence of collisions between rail and highway vehicles at crossings	2.1	Grade crossing collision

**Table 3-1. Relationship Between Safety Requirements Categories and Collision Scenarios (continued)**

Safety Requirements				Collision or Scenario Group (Tables 2.1-2.4) and Scenarios	
Overall Function	Reference	Category	Functions	Reference	Description
Collision Avoidance	4	Brake system design and Performance	Ensure that vehicle or train has the capability to reduce speed or stop when required	Group 1 Group 2 Group 3 Group 4	Collisions between similar trains (all scenarios) Collisions with guideway obstructions (all scenarios except 2.8 and 2.9) Collisions between dissimilar trains (all scenarios) Single train events caused by excessive speed (all scenarios)
	5	Operating rules and practices	Reduce risk of human error accidents	Group 1 Group 2 2.3 2.4 2.6 Group 3 Group 4	Collisions between similar trains (all scenarios) Collisions with guideway obstructions Employee on guideway Maintenance equipment Overrun at guideway end Collisions with dissimilar vehicles or trains (all scenarios) Single vehicle/train events due to excessive speed (all scenarios)
	6	Operating staff qualifications and training	Reduce risk of human-error accidents	As for Category 5 above	

**Table 3-1. Relationship Between Safety Requirements Categories and Collision Scenarios (continued)**

Safety Requirements				Collision or Scenario Group (Tables 2.1-2.4) and Scenarios	
Overall Function	Reference	Category	Functions	Reference	Description
Accident Survivability	1	Overall vehicle structure	Ensure integrity of vehicle occupant space in a collision	Group 1 Group 2 2.4 2.6 Group 3 Group 4	Collisions between similar trains (all scenarios) Collisions with guideway obstruction Maintenance equipment Overrun at guideway end Collisions between dissimilar trains (all scenarios) Single vehicle event (all scenarios)
	2	Operator's cab structure	Ensure integrity of cab occupant space in a collision. Minimize consequences of impact between occupant and cab interior equipment and surfaces.	As for Category 1 above	
	3	Vehicle interior fittings and equipment	Reduce severity of impact between occupants and vehicle interior fittings and surfaces	As for Category 1 above	
	4	Window glazing impact requirements	Reduce risk of penetration of windows by objects propelled at or dropped in front of vehicle	Group 2 2.8 2.9	Collision with guideway obstructions Gunfire Objects dropped in front of vehicle or flying above guideway

## **2. Right-of-Way Security, Excluding At-grade Highway Crossings**

The incidence of obstructions on the guideway or intruding into the clearance required by an operating HSGGT vehicle or train can be reduced by suitable right-of-way security measures. Intrusion from an adjacent transportation right-of-way where the HSGGT service shares a transportation corridor with other modes is a specific cause of guideway obstructions. Right-of-way security measures include fencing and barriers to prevent intrusions, and systems to detect the presence of obstructions or intrusions. Fencing reduces the risk of animals or trespassers reaching the guideway and being struck by a moving vehicle. More substantial barriers can reduce the risk of heavier objects, such as out-of-control highway vehicles, intruding on the guideway.

The capabilities of the right-of-way security measures will affect the incidence of collisions in Group 2 (Table 2-2) "Collisions with Obstructions on the Guideway," specifically, 2.2 animal on guideway, 2.3 person on guideway, 2.5 debris on guideway, 2.7 rail or highway vehicle encroachment on guideway, and 2.8 object dropped or falling in front of vehicle.

## **3. At-grade Highway Crossing Warning and Protection Systems**

The purpose of at-grade highway crossing warning and protection systems is to reduce the incidence of collisions between rail and highway vehicles at such crossings. Warning systems inform highway users of the approach of a train and can be used to inform the train operator or controller of an obstruction at a grade crossing. Barriers may be used to protect against highway vehicle intrusion on the guideway. Highway-center barriers can be used to discourage weaving around crossing gates.

At-grade highway warning and protection systems reduce the incidence of scenario 2.1 (Table 2-2), grade crossing collisions.

## **4. Brake System Design and Performance**

Brake system design and performance requirements have the purpose of ensuring that the brake system is always available for use, and that the required performance in terms of stopping distances can be achieved under all normal operating conditions. The overall requirement is independent of the type of brake system used, but many individual safety requirements apply to specific types of braking systems.

Brake systems performance is critical to avoiding the collision scenarios in Group 1 (collision between similar HSGGT vehicles) and Group 3 (collisions between dissimilar vehicles or trains), and may contribute to avoiding the collision scenarios in Group 2 (collisions with obstructions on guideway).

## **5. Operating Rules and Practices**

Operating rules and practices are needed to govern both automated and manual HSGGT operations and on-guideway maintenance activities. Operating rules typically include those governing the fitness of employees when on duty; routine daily, pre-departure, and other safety checks; emergency operating procedures; and similar matters.

Good operating rules and practices will reduce the risk of human-error-caused collisions in Group 1 (collisions between similar HSGGT vehicles) and Group 3 (collisions between dissimilar trains). These rules and practices also will be instrumental in reducing the risk of employees or maintenance equipment being struck by an HSGGT vehicle (scenarios 2.3 and 2.4). The incidence of Group 4 accidents (single train events) caused by excessive speed also will be reduced.

## **6. Operating Staff Qualifications and Training**

However much operations are automated, almost all HSGGT systems will rely on manual operators for some aspects of system activities, especially in emergency operations following an automated system failure. Appropriate qualifications and training requirements must be followed to ensure that system employees can safely undertake both normal and emergency duties, and to minimize the incidence of human error accidents.

Staff qualifications and training requirements help reduce the incidence of all train-to-train or vehicle-to-vehicle collisions (Group 1, collisions between similar vehicles or trains, and Group 3, collisions between dissimilar vehicles or trains). In addition, qualifications and training are important in minimizing the risk of a system employee being struck by an HSGGT vehicle (scenario 2.3, person on guideway) and of collisions between HSGGT vehicles and maintenance equipment (scenario 2.4).

### Accident Survivability

Accident survivability safety requirement categories cover those requirements that help mitigate the severity of consequences once an accident has taken place. These include requirements for vehicle structures to maintain the integrity of occupant spaces in the vehicle during a collision, measures to reduce the severity of injury when vehicle occupants are thrown against internal fittings and surfaces in an accident, and design specifications to prevent penetration into the occupant spaces of the vehicle by objects dropped in front of or propelled at an HSGGT vehicle.

Individual categories are described below.

### **1. Overall Vehicle Structure**

Overall vehicle structure requirements govern the ability of the vehicle to protect the occupants in a collision with other vehicles or an end of the guideway. Occupant protection can be achieved by minimizing the risk that occupant space will be lost by gross crushing, and as far as possible providing for the absorption of collision energy by deformation of the unoccupied parts of the vehicle or train. Connections between vehicles or vehicle-sections should be designed to minimize the risk of vehicle override, jackknifing, and rollover.

Overall vehicle structure requirements address all collision scenarios where an HSGGT may collide with another train or a large object such as a major piece of maintenance or inspection equipment. These scenarios include all in Group 1 (collisions with similar HSGGT vehicles) and Group 3 (collisions with dissimilar trains), 2.4 (collisions with maintenance equipment), 2.6 (overrun at guideway end), and 4.3 (derailment followed by collision with an adjacent structure).

## **2. Operator's Cab Structure**

Operator's cabs are usually at the lead end of a vehicle or train and are thus at special risk of loss of occupant space and of severe impact between the occupant and interior surfaces in a collision. As a result, safety requirements specifically applicable to cabs have been developed and are reviewed under this heading. The collision scenarios addressed are the same as those listed above under Category 1, (overall vehicle structure).

## **3. Vehicle Interior Fittings and Equipment**

A major source of injury in guided vehicle accidents is impact between vehicle occupants and interior fittings and surfaces resulting from the sudden acceleration pulse applied at the time of collision. Occupants also may be hit by unsecured baggage, or fittings that break on impact. The severity of such injuries can be mitigated by appropriate attention to the strength of interior fittings, and avoidance of sharp corners and hard surfaces.

The collision scenarios addressed by this category of safety requirement are the same as those listed for Category 1 (overall vehicle structure).

## **4. Window Glazing Impact Requirements**

Windows are normally the weakest part of a vehicle's outer skin, and thus are the most vulnerable to penetration by smaller objects above the guideway or propelled at the vehicle or train. Thus, requirements have developed for the impact resistance of windows. These requirements address the ability of both forward-facing and side-facing windows to resist impacts from gunfire (Scenario 2.8) and objects dropped in front of the vehicle or flying above the guideway (Scenario 2.9).

Reviews of safety requirements applicable to HSGGT systems within each of the categories described above are provided in the remainder of this chapter. Each review is organized as follows:

1. Summary of specific safety concerns that are typically covered by safety requirements, plus a technical background related to these concerns.
2. Summary of existing U.S. railroad requirements in each category. This is provided for comparison with the foreign requirements.
3. Summary of international requirements in each category. These requirements include the UIC Code of practice developed primarily by and for the European railways, plus any practices that are generally followed by several systems.
4. Descriptions of standards, regulations, practices, and safety-related design features applicable to individual HSGGT systems. Safety-related practices and design features are included because foreign rail systems are all currently government-owned, and most are self-regulating at the level of detailed technical safety requirements. Compliance with the UIC Code is only required for vehicles used in international traffic, and is otherwise voluntary. Thus, there is a difference

between the U.S. situation, where a government agency must explicitly regulate private operators, and Europe, where a national government department is itself the owner and operator as well as being responsible for safety regulation. This situation means that safety issues are considered by the railway systems in the design, manufacture, and operation of foreign HSGGT systems, but are not expressly embodied in published regulations.

Tables 3-2 and 3-3 summarize the principal characteristics of the HSGGT systems described. Table 3-2 gives the characteristics of the vehicles and Table 3-3, the characteristics of both newly constructed and existing infrastructure.

A list of abbreviations used in this report and in connection with HSGGT systems in general is provided at the front of this report.

The primary source for the information is Reference 2, with updates and additions as required to reflect later developments.

## **3.2 COLLISION AVOIDANCE**

### **3.2.1 Signal and Train Control Systems**

#### **1. Introduction and Summary**

There are three primary functions of a HSGGT signal and train control system.

- a. *Ensuring route integrity.* This is the process of ensuring, before issuing a "movement authority" to a train, that the track or guideway is clear of other trains or vehicles, or any obstruction; that turnouts are properly aligned; and that no conflicting movement authorities have been issued. The equipment that performs this function is called an interlocking in traditional railroad terminology. Until recently, interlockings comprised hard-wired relay logic, but software-controlled microprocessor systems are now being used. Manual performance of this function is unheard of on a high-speed system, except for emergency low-speed operations after an equipment failure. Key inputs to the interlocking system are the locations of all trains, current movement authorities, and the status of turnouts.
- b. *Communication of movement authorities to operator or control system.* The purpose of an interlocking is to ensure that only safe movement authorities can be issued. The next step is to ensure that these authorities are conveyed correctly to either a human operator (on the vehicle or in a fixed control center), or to an automatic train operation (ATO) system. On a traditional railway, this is done by the train operator's observation of lineside signals. On high-speed wheel-on-rail systems, lineside signals are supplemented or replaced by in-cab signals or displays. On automated and semi-automated transit systems, the human operator's functions are replaced by the ATO system, which receives and acts on movement authorities. In some automated and cab signalling systems the communication system provides feedback that the correct signal or instruction has been displayed or received.



**Table 3-2. High-Speed Rail Rolling Stock Summaries (as of 1/1/92)**

<b>Train/ In Service Date</b>	<b>Operator(s)</b>	<b>Guideway Configuration</b>	<b>Train Configuration (see footnote)</b>	<b>Service Speed (km/h)</b>	<b>Max. Test Speed</b>	<b>Power Car Material</b>	<b>Passenger Vehicle Material</b>	<b>Right-of-Way</b>	<b>Tilt Body</b>
German ICE 1991	German Federal Railways (DB)	Railroad	LL	250-280	406	Steel	Aluminum	New and existing routes	No
German Class 120 c1982	German Federal Railways (DB)	Railroad	CL (Locomotive only)	200	248	Steel	Steel	Existing track	No
German Maglev Prototype	N/A	Beam Maglev	MU	400+ (planned)	419	N/A	Aluminum	New beam type guideway only	No
French TGV 1980 PSE 1989 Atlantique	French National Railways (SNCF)	Railroad	LL - frequently two full train sets	270, 300 higher in future 220 on existing track	515	Low alloy high tensile steel	Low alloy high tensile steel, aluminum in future	New and existing routes	No
French ANF Turbo c 1970	French National Railways (SNCF) & Amtrak	Railroad	LL	190 France 175 USA	260	Steel	Low alloy high tensile steel	Existing track in France and US	No
Swedish X2000 1991	Swedish State Railways (SI)	Railroad	PP	200	Not available	Stainless steel	Stainless steel	Existing upgraded routes	Active
Swiss Bahn 2000 Prototype	Swiss Federal Railways (SBB)	Railroad	PP	200	Not available	Not known yet	Aluminum likely	Existing main lines & new 200 km/h routes	Under investigation
Italian ETR 500 Prototype	Italian State Railways (FS)	Railroad	LL	270	Not available	Aluminum/ steel	Aluminum	Existing and new routes	No
Italian ETR 450 1989	Italian State Railways (FS)	Railroad	MU	250, but 200 on existing track	Not available	N/A	Aluminum	Existing and new routes	Active

See next page for footnotes.

**Table 3-2. High-Speed Rail Rolling Stock Summaries (continued)**

<b>Train/ In Service Date</b>	<b>Operator(s)</b>	<b>Guideway Configuration</b>	<b>Train Configuration (see footnote)</b>	<b>Service Speed (km/h)</b>	<b>Max. Test Speed (km/h)</b>	<b>Power Car Material</b>	<b>Passenger Car Material</b>	<b>Right-of-Way</b>	<b>Tilt Body</b>
Spanish TALGO Pendular 1980	Spanish National Railways (RENFE)	Railroad	Unpowered trainset only	160 initially, potentially higher	(higher in Germany)	N/A	Long aluminum extrusions	Existing track	Passive
Spanish AVE 1992	Spanish National Railways (RENFE)	Railroad	LL (Derivation of TGV-Atlantique)	250 300 planned	Not Available	Low alloy high tensile steel	Low alloy high tensile steel	New track only	No
British IC225 1991	British Rail (BR)	Railroad	PP	200 initially 225 proposed	Over 250	Low alloy high tensile steel	Low alloy high tensile steel	Existing track, enhanced signals over 200 km/h	No
British HST (Intercity 125) 1970	British Rail (BR)	Railroad	LL	200	231	Conventional steel	Conventional steel	Existing routes	No
Canadian LRC 1980	Canada VIA - RAIL with Amtrak	Railroad	LL	150	210	Steel struct. w/ aluminum sheeting	Welded aluminum	Existing routes	Active
Japanese Shinkansen 1964	Regional oper. companies in JR Group	Railroad	MU	210-260	320+	N/A	Steel or aluminum	New routes only	No
Japanese Maglev Experimental	Regional oper. companies in JR Group	Railroad	MU	500+	Approx. 500	N/A	Aluminum	New trough type guideway only	No

\* Train configuration:

MU = Multiple Unit. All or most cars are powered

CL = Conventional Locomotive.

PP = Push Pull: Locomotive at one end, unpowered cab vehicle at other.

LL = Trainset with power car at each end.

N/A = Not Applicable

**Table 3-3. High-Speed Rail Infrastructure Summaries (Trains in Service, 1992)**

Country	Train Systems	New Infrastructure			High Speed on Existing Track		
		Maximum Speed (Km/h)	Mixed Use?	Signals	Maximum Speed(km/h)	Grade Crossings?	Signals
France	TGV	300 Atlantique 270 PSE	No	Cab signals w/ ATP, various types	220 in selected locations	Yes, believed up to 200 km/h cab and ATC	Lineside supplemented by
France	ANF Turbo	Not used on new infrastructure			190	Yes	Lineside signals, supplemented by cab and ATC
Germany	ICE	280	Yes, freight and conventional passenger	Cab signals w/ATP cont. track-train communications	200 in selected locations	Yes, up to 200 km/h	Lineside supplemented by cab and ATC
Sweden	X2	No new infrastructure			200 where track permits	Yes, up to 200 km/h with special precautions	Lineside + cab + ATP
Italy	ETR 450	250, possibly higher	Yes, freight	Cab signals w/ATP & conventional block signal	125 in selected locations	Believed yes, up to 125 km/h	No information
Spain	AVE (TGV derivative)	300	Yes, 160 km/h freight Talgo at 200 km/h using S252 locomotive (variant of German 120)	Cab signals w/ATP cont. track-train communication	None (AVE operates on different track gauge than rest of Spanish system)		
Britain	IC225 HST	No new infrastructure			200 now 225 future (IC 225)	Yes, normally not over 200 km/h	Lineside + simple cab + ATC, ATP for 225 km/h
Japan	Shinkansen (several variants)	220-270	No	Cab signals w/ ATP	No high speed on existing track (different track gauge than high speed lines)		
Canada	LRC	No new infrastructure			150 only	Yes, to 150 km/h (law)	Lineside + cab signals and ATC
USA	ANF Turbo, NE Corridor Metroliner	No new infrastructure			177 - ANF Turbo, 200 NE Corridor (Amfleet Metroliner and AEM7)	Max 177, very few over 145 (NY -Albany line)	Lineside + cab and ATC over 127 km/h

- c. *Safe-speed enforcement.* Whether vehicles are under manual or automatic control, the safe speed enforcement system ensures that movement authorities and speed limits are not exceeded. This function is usually carried out by an Automatic Train Protection (ATP) system. Such a system may have partial or full capabilities. For example, a simple ATP system may initiate braking if signal indications are not obeyed, but will not be capable of detecting and overriding the operator when speed limits are exceeded. ATP systems that have partial capabilities are known also as Automatic Train Control (ATC) systems. Many conventional rail systems lack any kind of safe-speed enforcement, relying completely on the capabilities of the human operator. However, all HSGGT operations at speeds over 200 km/h (125 mph) are equipped with a comprehensive ATP system that enforces obedience of speed limits and train control instructions, and cannot be overridden by the train operator when the train is operating at high speed.

Safety-critical components in signal and train control systems are generally known as "vital" components. Vital components must be designed so that there is a very low frequency of occurrence of dangerous "wrong-side" failures, leading to the display of a false "proceed" signal to an operator, or permitting conflicting train movements. The low failure frequency is achieved in traditional signal systems by designing vital components to be intrinsically "fail-safe", so that any failure leads to more restrictive signal indications. In modern microprocessor systems, the required performance is achieved by using fault-tolerant architecture that can continue to function safely after a single failure. Centralized Train Control (CTC) systems and ATO systems are not usually designed to "vital" standards, since signal indications and train movements are overseen by independent ATP and interlocking systems.

In general, interlocking systems developed for the conventional railroad and mass transit industries, together with their technical requirements, have been adopted by HSGGT systems. The primary safety step taken by most HSGGT systems is the addition of a high-capability ATP system for safe-speed enforcement. The objective is to minimize the risk of human error leading to a collision or derailment by either automating or automatically supervising the operator's actions.

ATP systems can be characterized by the complexity of information that can be transmitted between the control center and the train, usually via trackside transmitters, and whether this information is updated continuously or intermittently.

Intermittent systems transmit a "packet" of data to a train as it passes a wayside beacon. The data typically includes line speed limits and required speed at the next signal. On-train equipment calculates the braking action to attain the required speed, and automatically initiates braking if the operator fails to do so. Intermittent systems are relatively economical and interface well with existing signalling systems. They are not well suited to high density operation, where trains follow one another at close headways such as on a mass transit system, because a train can respond to a changed situation only after it reaches the next beacon.

Continuous ATP systems maintain constant guideway-to-train communication, and updated data can be conveyed to the train at any time. The traditional form of continuous ATP using coded track circuits to transmit data has very limited capacity, typically a small number of signal or "permitted speed" indications. Coded track circuit systems of this type are used on the Japanese Shinkansen, the Atlantique and Paris-South-East TGV lines, and many mass transit systems.

More sophisticated continuous systems have now been developed, such as the German LZB and the French TVM430 systems, which have a high data capacity.

## **2. U.S. Regulations, Standards, and Practices**

### FRA Regulations

49 CFR Part 236.0 requires that trains operated at speeds of 80 mph or higher be equipped with an automatic cab signal, automatic train stop, or automatic train control system. These systems must operate in connection with an automatic block signalling system and either display the same or a more restrictive signal aspect in the cab, and/or initiate braking if a restrictive signal aspect is passed and the engineer fails to initiate braking. Braking must be initiated early enough for the train to stop before an occupied block or conflicting turnout setting. Automatic train stop or control systems may include a device by which automatic brake application can be forestalled. Every train operating in automatic train control or cab signal territory must be equipped with a system meeting these requirements. Part 236 also includes a large number of detailed requirements regarding track circuit operation, automatic block systems, and individual signalling devices.

The Chase, Maryland accident described in Chapter 2 resulted in an enhancement to the ATC regulations for the Northeast Corridor between Washington and Boston and certain connecting routes. The new regulations require all trains operating in the corridor and on the other designated routes to be equipped with cab signals and a system that automatically initiates braking should the engineer fail to respond to or acknowledge a more restrictive signal indication. New penalties for unauthorized tampering with ATC equipment were also introduced.

49 CFR Part 220 contains instructions for radio communications and procedures for issuing train orders by radio. Also, all radio communications and radio equipment must comply with Federal Communications Commissions (FCC) requirements. FCC requirements would apply to any new train control system using radio communications introduced into the U.S. as well as to existing systems.

### Other U.S. Standards and Practices

Detailed signal system standards and recommended practices are published by the Communications and Signal Division of the Association of American Railroads (AAR). These are primarily concerned with detailed manufacturing and installation requirements for individual components and devices rather than overall requirements associated with different speed levels, and have not been reviewed in detail.

## **3. Foreign Standards and Practices**

International Union of Railways (UIC) Code 734 R provides recommendations for signalling systems for high speed lines. These reflect the characteristics of the signalling and train control systems used on the French, German, and Italian high speed lines.

The principal provisions of these recommendations are:

- Traditional lineside signals are acceptable up to 140/160 km/h (87-100 mph).
- Between 160 and 200 km/h (100 and 125 mph), traditional signals should be enhanced by cab signals and/or automatic train control, and an additional signal aspect or other form of advance warning of a restrictive signal aspect must be added to accommodate the longer braking distances at higher speed.
- Above 200 km/h (125 mph), full cab signalling and continuous automatic train protection with speed supervision must be provided. The speed supervision should include all temporary and permanent civil speed restrictions, and be capable of responding to fault detection systems. Lineside signals cannot form part of the system, except as a lower speed backup. Trains also must be provided with voice communication to the dispatcher. On mixed traffic high-speed lines, slower traffic does not have to be equipped with the high speed ATP system. It should be noted that the systems presently installed on the German, French, and Italian high speed lines do not necessarily meet all of these requirements.

UIC Code 738, "Processing and Transmission of Safety Information," is concerned with the safety of microprocessor and communication system hardware and software used for vital train control purposes. Techniques to be used to validate and verify software specifications, design, and coding are specified, as well as techniques to ensure that a system will respond in a safe fashion to hardware failures. The increasing use of microprocessor controls in safety-critical HSGGT applications means that the safety assurance of such systems will be of increasing importance and concern.

In addition to Codes 734 and 738, the series of UIC codes 730-739 contain many detailed requirements for signal systems in a similar fashion to the AAR standards. A list of UIC codes relevant to signalling and control systems is shown in Table 3-4.

Regarding general practice in European countries, there is a significant trend, notably in Sweden and France, to install an ATP system with speed supervision on all principal lines in an effort to reduce human-error accidents. In the U.K., improved ATP systems are being installed on principal lines following the disastrous collision at Clapham in South London in 1988, described in Section 2.5.

#### **4. Specific HSGGT Practices**

##### **Germany**

German Federal Railways has developed a continuous automatic train protection and track-train communication system called LZB (for Linienzugbeeinflussung). This system is being applied to both the new lines and upgraded existing lines to maintain safe separation between trains and provide safe-speed enforcement.

A schematic of the LZB is shown in Figure 3-1. The heart of the system is the LZB center, essentially a "vital" train control computer that determines authorized speeds and distances to

**Table 3-4. UIC Codes for Signal and Train Control Systems**

UIC-641-0	Conditions to be fulfilled by automatic vigilance devices used in international traffic
UIC-730	General signal installation
UIC-731-R	Inspection of signalling installations
UIC-733-R	Signalling on lines equipped with automatic block
UIC-734-R	Recommendation for signalling systems for HS lines
UIC-735-I	Speed and directional signalling
UIC-736-I	Signalling relays
UIC-738-R	Processing and transmission of safety information
UIC-739	General signal installation
UIC-760-OR	Level crossings: road signs and signals
UIC-780-I	Remote control of signalling installations

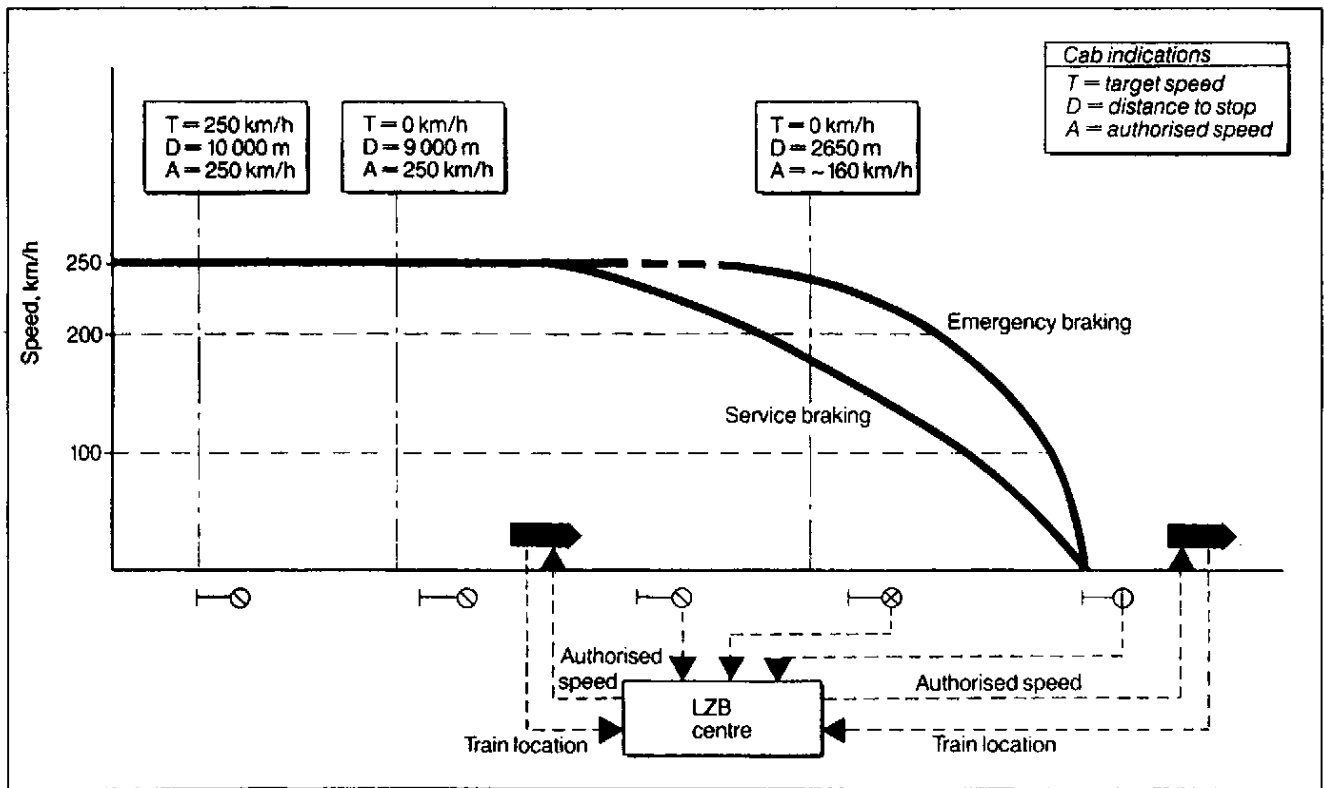

Source: Railway Gazette International, July 1986

Figure 3-1. Schematic of German Federal Railways LZB Automatic Train Control System



stop, and transmits this information to the train. Onboard equipment compares the authorized speed with actual speed. If the actual speed exceeds the authorized, the operator is warned, and if there is no response to the warning, emergency braking is initiated. The lineside train-control computer is based on the Siemen's SIMIS fault-tolerant microprocessor architecture, which uses a two-out-of-three voting system to ensure a high level of safety. The SIMIS microprocessor performs the interlocking function of train control, receiving data route status, switch position, train location, and permanent and temporary speed restrictions, and provides authorized speed and distance-to-stop data to the train. The SIMIS microprocessor also controls lineside signals, installed on the newly constructed lines (NBS) for freight and other trains not equipped with LZB onboard equipment. One lineside signal block contains several LZB blocks, which are used to provide greater track capacity and more precise speed control for high speed trains. Non LZB-equipped trains are limited to conventional speeds, and their presence reduces track capacity.

The normal method of track-train communication is via an inductive loop laid on the track, an extension of mass transit system practice. However, the inductive loop is costly and vulnerable to vandalism and damage, especially by track maintenance activities, and DB is experimenting with high frequency radio data links as an alternative.

## **France**

French National Railways (SNCF) has been developing several advanced signal and train control systems for high speed and conventional lines. They include the following:





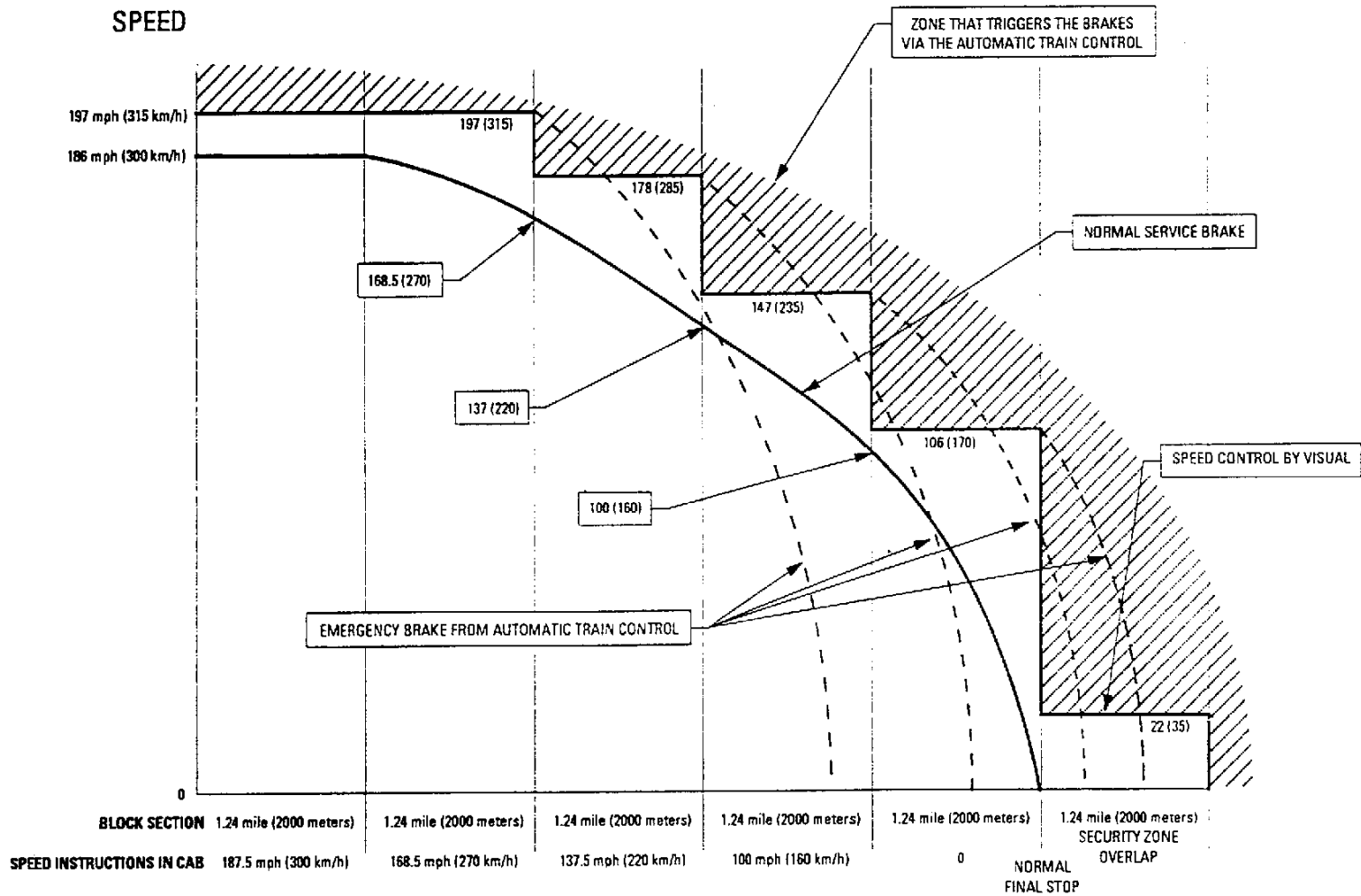





- a. The TVM 300 signalling system, used on both the TGV Paris-Southeast and Atlantique lines, depends on coded track circuits for track-to-train communication. At the beginning of each block the train receives data from the coded track circuits indicating the maximum permitted speed at the end of the block, as illustrated in Figure 3-2. The operator cab displays providing the speed commands are shown in Figure 3-3. There are no lineside signals, only marker boards to indicate the start of each block. Blocks are 2.1 km long on the PSE line, 2.0 km on the Atlantique line, and will be 1.5 km on the TGV Nord to the Channel tunnel with an enhanced signal system called TVM 430. The permitted speed, or the target speed at the next marker if a speed reduction is required, is displayed in the cab. If the "control" speed (as shown on Figure 3-3) is exceeded, then an automatic brake application is made. Normally, this speed is 15 km/h (10 mph) above the maximum speed allowed in the block. "Stop and proceed" is allowed from a stop at selected markers (those not protecting a turnout) at a maximum speed of 30 km/h (19 mph). The engineer also has a voice radio contact with the TGV control center.

The high speed lines are used exclusively by TGV trains, and with one minor exception, there has been no need to adapt the signalling or any other feature of the infrastructure to the needs of conventional trains. This restriction made possible the very steep grades used (3-5%) and the resulting reduction in infrastructure costs. The exception is the portion of the Atlantique line that bypasses the city of Tours, where conventional lineside signals have been added for use by conventional trains. The Atlantique signal and communication systems are compatible with both the original PSE TGV's and the newer Atlantique trains.



Source: GEC-Alsthom, 1992.

Figure 3-2. Speed Control and Braking Distances on the TGV Atlantique

INFORMATION		SPEED CONTROL	MEANING
TRACK	CAB		
VL	 Black letters on green background	285	RUNNING AT THE SPEED LIMIT OF THE LINE
270	 Black figures on green background	285	RUNNING AT 270 km/h BUT SPEED REDUCTION POSSIBLE ON ENTERING NEXT SECTION
220A		285	WARNING INDICATIONS THAT THE DRIVER MUST BE CAPABLE OF NOT EXCEEDING THE CORRESPONDING SPEED ON ENTERING THE NEXT SECTION
160 A		235	
80 A	 Black figures on white background	170	
220E		235	OPERATING INDICATIONS ORDERING THE DRIVER NOT TO EXCEED THE CORRESPONDING SPEED
160E		170	
80E	 White figures on black background	90	
01 } 02 }	 Black figures on red background	170 90	STOP INDICATION ORDERING THE DRIVER TO STOP AT THE FIRST MARKER HE REACHES WITHOUT EXCEEDING 160 km/h IF THE PREVIOUS INFORMATION WAS 160 E OR 160 A and 80 km/h IN ALL OTHER CASES
00 } 0 }	 Screens lit red	35	INDICATION ORDERING THE DRIVER TO RUN UNDER CAUTION, WITHOUT EXCEEDING 30 km/h AND TO STOP AT THE NEXT MARKER

TGV Atlantique trains have one extra speed step to 300 km/h, as illustrated in Figure 3.2

Source: UIC Code 734R

**Figure 3-3. Cab Signals Used on French TGV Trains on the Paris-South East High-Speed Line (Speeds in km/h)**

The TVM 430 signalling system being installed on the TGV Nord and in the Channel tunnel utilizes microprocessor interlocking and digital track-to-train communications both through the rail and with intermittent transponders. Shorter blocks and the greater data transmission capabilities possible with this system result in shorter headways and greater track capacity. Proposed minimum headways are 3 minutes at 300 km/h (187 mph). Track circuits perform the train location function.

- b. The SNCF "Astree" (Automatisation du Suivi en Temps) System (roughly translated as automated real-time monitoring of movement) is expected to be deployed in the late 1990s. The goal of the system is to provide SNCF with system-wide location and control of train movements in real-time. Doppler radar is used on-board to calculate the distance run by motive power units. Alternatively, an electric odometer has also been used to designate track positions. Radio beacons have been developed to identify vehicles. Each train will continuously calculate its position and transmit this information to a control center where train movements are monitored. This system is still under development, and many details are yet to be finalized.
- c. During 1990 and 1991, SNCF trains on the Line A of the RER commuter system in Paris were outfitted with the SACEM (Systeme aux a la conduits et la maintenance) (system to aid operations and maintenance) speed control and signalling system. SACEM integrates comprehensive Automatic Train Operation (ATO), Automatic Train Protection (ATP), cab signalling, service regulation, and maintenance diagnostics of trains. Maximum track capacity is attained by allowing a train to enter a "sub-block" approaching a station before a preceding train has left the far end of the platform.

With SACEM-equipped trains, signals are displayed to the driver in the cab. When the train approaches a lower speed limit, a buzzer will sound in the cab and a yellow, lighted display will indicate the new speed limit. Once the lower speed is achieved, the display turns green.

- d. Because the very ambitious Astree program has a long implementation time, SNCF is also installing a simpler, intermittent ATP system on principal routes, similar to the Swedish system described below. This system was tested in 1991 and is scheduled to be completed by 1994. In connection with ATP systems, "intermittent" means that information is transferred to the train at discrete points using lineside transponders—for example, at each signal—rather than continuously. This action was taken, in part, in response to a series of accidents in the mid-1980s, and was accelerated after the serious accidents at the Gare de Lyon, Paris, in 1988, and at Melun in 1991. This system is known in France as KVB (control of speed [vitesse] by beacon).

## **Sweden**

Swedish State Railways (SJ) is installing an ATP system that will cover 90% of the routes in operation, including, but not limited to lines over which the X2000 high speed train will operate. The principal capabilities are:

- Indication of speed limits
- Indication of target speed
- Warning and braking when the speed limit is exceeded
- Warning and braking when the driver does not reduce speed sufficiently when approaching a lower speed limit
- Emergency braking if the train passes a stop signal

For lower volume lines in rural areas, a simpler ATC system will provide the train operator with warning information. On lines where the 200 km/h (125 mph) X2000 train will operate, detectors are provided at-grade crossings to provide a warning if the gates have not been lowered at the correct time, or if the crossing is obstructed by a highway vehicle after the gates have been lowered. Detection of an unsafe condition results in a stop command being transmitted to the train.

## **Switzerland**

The Bahn 2000 project for new lines and 200 km/h (125 mph) operation on Swiss Federal Railways (SBB) will include implementation of an enhanced signalling system with three features: lineside signals, cab signals, and ATP.

- The lineside display at each signal will be modified to indicate the maximum speed in km/h at which a train may pass the next signal. For example, 16 displayed means that the next signal may be passed at 160 km/h (100 mph). This indication will not provide speed limits applicable to a specific train type, which may be lower than the line speed limit.
- An "intermittent" cab signalling and ATP system. The lineside conventional signal aspects and speed indications are displayed in the cab. If a speed reduction is required, an onboard control system compares actual train speed with the computed full-service braking speed/distance curve needed to achieve the required speed reduction, and overrides the operator if the actual speed exceeds a safe level. Normally, an operator will brake a train with less than full-service braking, leaving a margin between actual speed and the speed that would cause a "penalty" brake application. An otherwise similar ATP system with continuous communication will also be tested. Continuous communication will be required for speeds exceeding 160 km/h (100 mph), and where traffic density is very high.

For the past 50 years SBB has used the "Integra" Automatic Warning System (AWS), which today takes the form of visual and acoustical warning in the cab at every signalled speed restriction. Emergency braking is initiated if no action is taken after 100m (350 ft).

## **Italy**

The mixed freight and passenger traffic of the Direttissima high speed infrastructure requires conventional block signalling alongside a continuous cab signalling and automatic train control system for use by the high speed trains. The high speed line is fully grade-separated from highways and other rail lines.

## **Great Britain**

For many years, British Rail (BR) relied on a simple Automatic Warning System (AWS). This system simply provided a visual and audible indication of a "caution" signal approximately 300m (1000 ft) before the actual signal. The warning indicates that a stop may be required one block beyond the caution signal. Brakes are applied automatically if the in-cab indicator is not cancelled. This system is used on all lines, including those over which 200 km/h (125 mph) trains are operated, except high traffic density commuter lines where it was considered unsuitable.

The disastrous accident at Clapham in South London in late 1988 has now led to a requirement that a more sophisticated "Automatic Train Protection" (ATP) system be installed on all routes except low-traffic rural and freight-only lines. The detail specifications for the ATP system are evolving, and pilot installations are expected to be operational in 1992. The basic requirement is that ATP should override the train operator and apply brakes whenever speed limits (for the vehicle or the track) or signal indications are not obeyed.

An operational ATP is also required for speeds exceeding 200 km/h (125 mph), for example with the new IC 225 trains now in service between London, Northeast England, and Edinburgh. The IC 225 is a "new generation" train, first put into service in 1990. It differs from the IC125 diesel-electric train in having electric traction, a push-pull consist with a locomotive at one end and a cab/baggage car at the other, and a top speed of 225 km/h (140 mph).

British Rail also has developed a "vital" radio-based signalling system for use on single track, low density lines, called Radio Electronic Token Block. A digital radio message authorizing a train to occupy a segment of track is transmitted to the train from a remote control location, and is displayed to the train operator. A vital microprocessor system at the control center ensures that only one train can be given permission to occupy a track segment at one time. This is not an ATP system, since adherence to the authorization depends on the train operator, but the system eliminates the need for lineside equipment, other than a passive transponder, to determine train location.

## **Japan**

The three major components of the signal and control system on the Shinkansen high speed lines are an ATP system, a Centralized Train Control (CTC) system with the COMTRAC traffic control system, and voice radio.

A continuous ATP system with automatic override of the operator in case of overspeed is used on all Shinkansen lines. Cab signalling only is used; there are no lineside signals. All operations on each line are controlled from a control center in Tokyo. Figure 3-4 shows a typical control panel and Figure 3-5 shows the detail of a portion of the panel. Note the high wind and earthquake detectors. The earthquake detectors are connected directly to the train control system, so that operations can be stopped promptly if an alarm is received. Also supporting the train control is the COMTRAC traffic control system. This replaces manual route setting and aids the dispatcher in responding to train delays, but does not perform "vital" functions.

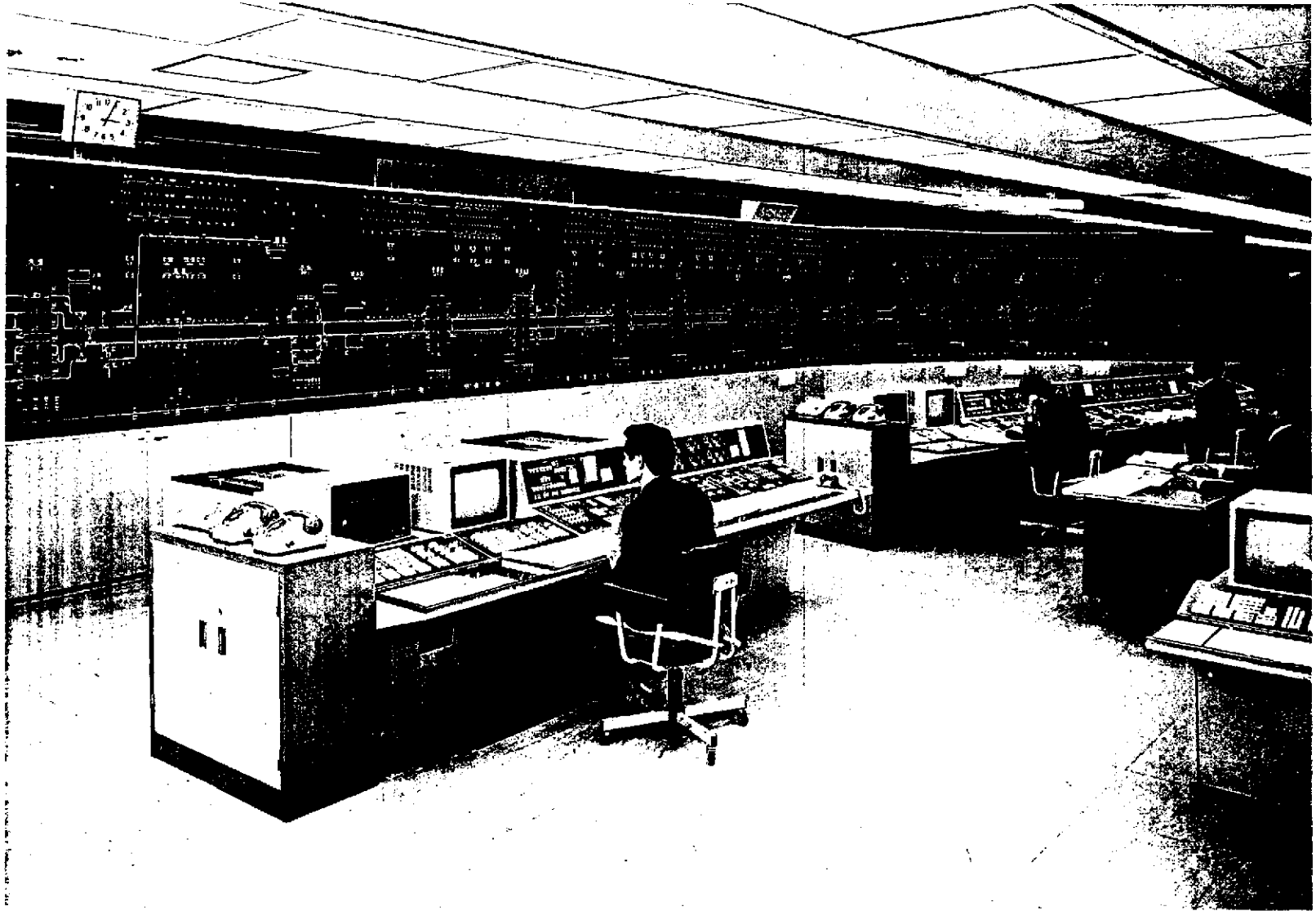

Figure 3-4. General View of Shinkansen Control Center

Note high wind and earthquake warning indicators

## Indication Panel

### TEMPORARY SPEED LIMIT INDICATOR:

When train speed is temporarily restricted, an orange lamp lights up for a 70km/h limit, a white lamp in the middle row for 110km/h and a white lamp in the outer row for 160km/h.

### WIND VELOCITY WARNING INDICATOR:

Lamps show wind velocities exceeding 20m/sec in white, 25m/sec in orange, and 30m/sec in red.

### ALTERNATIVE AUTOMATIC ROUTE SETTING INDICATOR:

A white lamp shows that routes through this station are being set automatically but not under COMTRAC control.

### MANUAL ROUTE-SETTING INDICATOR:

Orange lamps show that routes at this station are being set manually by dispatchers at the Center.

### STATION ROUTE-SETTING INDICATOR:

White lamps show that routes are being set at the station, independently of the Center.

### WAITING TRAIN INDICATOR:

This white lamp shows that a train is waiting at this station for another train to pass, under COMTRAC control.

### TRAIN TRACING INDICATOR:

A red lamp lights up when COMTRAC fails to trace a train.

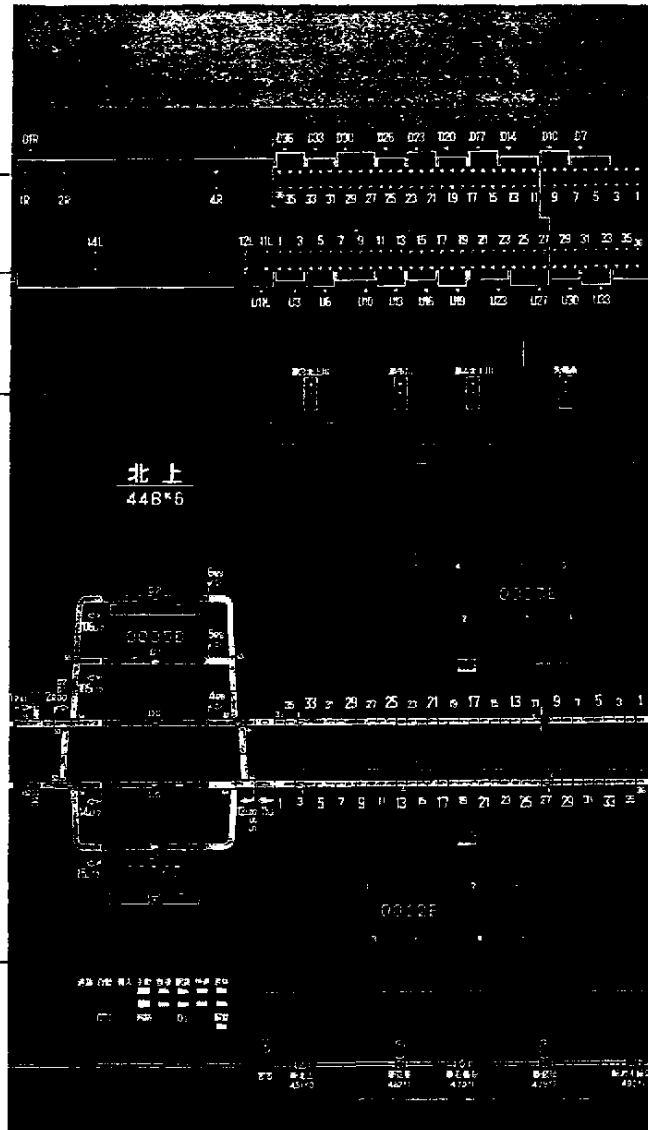

Tohoku Shinkansen Control Panel (Kitakami area)

### ROUTE OPENING INDICATOR:

Green arrow lights when a route is opened for a train to arrive at, depart from or pass through the station.

### TRAIN POSITION INDICATOR:

Each of the ATC block sections has a white indicator lamp lit when there is a train in that section.

### TRAIN NUMBER INDICATOR:

The train numbers of trains in the station and between stations are shown here.

### GROUND COIL INDICATOR:

This white triangle shows the location of a ground coil to check train numbers.

### POWER FAILURE INDICATOR:

When power supply to the overhead contact wire is cut upon detection of an accident or an earthquake, triangular red lamps light up and show the section.

### COASTAL EARTHQUAKE DETECTION INDICATOR:

A white lamp lights when sensors installed on the Pacific coast detect an earthquake 40 gals or over in intensity.

### EARTHQUAKE WARNING INDICATOR:

When earthquake sensors at substations along the line detect an earthquake of 40 gals or more, an orange lamp lights up. A red lamp lights for over 80 gals.

### FEEDER SECTIONING INDICATORS:

The mark indicates a feeder station, the  $\square$  a feeder sectioning post, the  $\square$  an auxiliary feeder sectioning post and the  $\square$  an AT post.

3-24

Figure 3-5. Detail of Shinkansen Control Panel



Key components of the ATP system include:

- Cab signal system
- Fixed block train location system using track circuits
- Safe speed enforcement: indication in driver's cab of speed limits, with automatic emergency braking if the driver does not respond

For higher speed lines up to 270 km/h (168 mph), the enhanced ATC-10 system is used with several added features:

- Dual frequency system: two signal frequencies are used to transmit signal information, thereby increasing the quantity and reliability of information.
- Maximum operating speed is set at 270 km/h (168 mph), with a standard block length of 1.2 km (0.75 mile)
- Triple redundancy system in the wayside and on-train equipment to improve reliability

The centralized train control (CTC) for the Shinkansen lines has the main function of indicating the status of train operation on the control panel (train locations, numbers, routes, wind velocity, earthquake information, etc.). The CTC system also controls the relay interlocking system of each station from the central office and provides for the surveillance of facilities.

A leaky coaxial cable (LCX) train radio system provides track-train voice communications and other phone-related services including public telephone, fax, electronic mail, and hotel and ticket reservations.

The Train Radio System was introduced in 1964 at the opening of the Shinkansen. Both the LCX installed along the entire line and connected to a radio station, and air-wave radio system are used in different locations.

"COMTRAC" is the computer-aided traffic control system that is used for controlling train routes or adjusting train movements if there is a service delay. "COMTRAC" is connected to the ATC system and has a 2-out-of-3 redundancy design for improved reliability. Other characteristics include the ability to provide automatic train control and route-setting systems capable of handling very high traffic densities, and monitoring snow, earthquake, and high wind warning systems.

### **3.2.2 Right-of-Way Security**

#### **1. Introduction and Summary**

This heading covers measures to reduce the incidence of or provide warning of intrusions on the HSGGT guideway or right-of-way. Intrusions can include trespassers who may vandalize guideway equipment or be struck by a moving vehicle, stray animals, miscellaneous obstructions such as rocks falling or being dropped on the guideway, and encroachments from out-of-control

or derailed vehicles operating on a parallel right-of-way. The specific hazards associated with at-grade highway crossings are discussed separately in Section 3.2.3 below.

A primary precaution taken on new high speed lines in France and Japan is full-length fencing of the right-of-way to guard against trespassers and stray animals intruding on the track. The use of an elevated right-of-way, such as with proposed Maglev systems, accomplishes the same objective.

Intrusion and hazard warning devices are used on some systems, especially on the Shinkansen (for earthquakes) and on the French TGV Atlantique, where the line shares a transport corridor with a highway. Warning systems also are installed at highway bridges over the TGV-Atlantique high speed line as a precaution against vehicles breaking through the bridge railing and falling on the track.

High speed train services, with maximum speeds between 200 and 220 km/h (125-137 mph) are operated on existing tracks in the U.K., France, and Germany, with conventional freight and passenger services on parallel tracks. No special precautions are considered necessary against an accident on an adjacent track impacting a high speed train. It should be noted that freight rolling stock and operations in Europe differ significantly from U.S. practice: European trains are shorter and lighter and many engineering and operating practices are similar to passenger train practice. However, precautions are taken on electrified lines to prevent accidental contact with high-voltage catenary or equipment.

Railroad track in the U.S. is not normally fenced and trespassing is common. This results in a large number of incidents where a trespasser is struck by a train.

## **2. U.S. Regulations, Standards and Practices**

### FRA Regulations

The only FRA regulation is in 49CFR paragraph 213.37 that requires vegetation near the guideway to be controlled so that it does not interfere with operations.

### Other U.S. Standards and Practices

The AREA manual provides specifications for fences, primarily to restrain livestock, but there are no standards or guidelines for where fences should be used, other than in the special case of snow fences. U.S. practice is not to fence railroad right-of-way, except locally where special protection is considered warranted.

Rock slide detector fences (fragile wire) are used where there is a risk of a rock fall encroaching onto the right-of-way. These are linked to the signal system and set signals to danger when activated.

High wind detectors are used in a few locations, for example, on the Union Pacific Railroad in Wyoming, where high winds have caused incidents with double-stack container trains or multilevel automobile carriers.

Some mass transit systems (for example, Atlanta and Washington Metros) have become concerned about encroachment onto their right-of-way caused by accidents on parallel freight railroads, and have installed warning and protection systems, such as intrusion sensors, physical barriers and impact sensors on structures. Also, high security fencing, up to eight feet high, is used by mass transit systems to reduce trespass in urban areas.

### **3. Foreign Standards and Practices**

UIC codes 730-3 and 965R set standards for automatic systems for warning personnel working on the track of approaching trains, and general guidance regarding safe procedures. There are no other requirements relating to right-of-way security.

### **4. Specific HSGGT Practices**

#### **Japan**

No uncontrolled access to track or level crossings is allowed. Japan's Diet passed a "special law governing punishment of acts of obstruction against safety of train operation on Shinkansen" to protect against malicious interference with high speed train operations.

Hazard detection systems, linked into the train control system, are used extensively on Japanese Shinkansen, especially for earthquakes, heavy snowfall, and high winds. An alarm triggers speed reductions or cessation of operations as appropriate. All new high speed lines are fenced throughout. In the winter, trains are mounted with snow plows, or snow along the track is melted with heated water from sprinklers.

#### **France**

A number of precautions against accidental intrusion have been taken on French high speed lines used by the TGV trains. Highway overbridges are equipped with "fragile-wire" detectors to warn if a heavy object or vehicle has fallen from the bridge onto the track. Berms and ditches are used between the rail line and parallel major highways to minimize accidental intrusion, and minimum lateral spacing requirements are applied, based on highway type and traffic levels.

#### **Great Britain**

British railroads have had to be fully fenced by law since the 1800s. The original reason was to prevent livestock from straying onto the right-of-way, and this is still a concern. However, fence maintenance is less than perfect, as illustrated by a 1984 collision with a cow that resulted in 13 deaths (described in Section 2.5). This accident led to a requirement for all multiple unit and unpowered cab cars to be fitted with a cow-catcher. No special precautions are taken on high speed lines, except measures to protect against accidental contact or malicious interference with high voltage catenary. Particularly, this applies to bridges over the railways, where parapet heights have been increased.

Another problem of concern in the U.K. is impact between railroad bridge structures and highway vehicles. For historical reasons, many rail-over-highway bridges do not have adequate height clearance to accommodate a legal maximum height road vehicle. Such bridges are

vulnerable to being hit by high road vehicles, resulting in bridge damage, distortion of the track, and accidents to trains. Various means are under consideration to provide for the detection of such accidents at the time of occurrence so that train operations can be stopped until the bridge has been inspected and the extent of damage ascertained.

### **3.2.3 At-Grade Rail-Highway Crossings**

#### **1. Introduction and Summary**

Rail-highway vehicle collisions at at-grade highway crossings are a significant class of accidents in all countries. The consequences are always serious for the road vehicle, and can also be for the train, if the road vehicle is a truck or other heavy vehicle. A notable recent incident was a collision in 1988 between a TGV trainset operating on a conventional existing line (not the new high-speed line) and an exceptionally heavy load on a "low loader" highway trailer. A similar accident also occurred on British Rail in 1970, involving an express passenger train (see Section 2.5.).

Methods of reducing the risk or severity of at-grade highway crossing collisions include:

- Elimination of grade crossings, where reasonable alternate routes for highway traffic are available.
- Grade separation where economically justifiable, based on rail and road traffic levels and the speed of railway operation.
- Addition of grade crossing warning and protection devices such as flashing lights, sound signals, and barriers.
- Programs to educate the public about the dangers of railroad grade crossings such as "Operation Lifesaver" in the U.S.
- Enhancement of warning and protection controls, especially to optimize the time between the start of the warning cycle and the passage of the train.
- Addition of a central barrier in the highway to discourage weaving through gates.

In spite of the risks, restricting train maximum speeds over grade crossings has not been a widely adopted policy. Some European railways (Germany, France, Italy) permit operations at 200 km/h (125 mph) over at-grade highway crossings, since eliminating all such crossings in the short term is considered economically impractical, and the practice is judged to be acceptable. In the U.K. and U.S., de facto practice has been to eliminate at-grade highway crossings where speeds exceed 140 to 160 km/h (90-100 mph), but this is not a legal requirement. Efforts are continuing in the U.S. to reduce the number of at-grade highway crossings on lines where higher speed services are operated or planned. Canada has a present legal maximum speed of 150 km/h (95 mph) over grade crossings, but this may be increased to 160-170 km/h (100-105 mph).

Grade crossings are considered totally unacceptable on all new high-speed lines, all of which are fully grade-separated.

## **2. U.S. Regulations, Standards, and Practices**

### FRA Regulations

There are no specific FRA regulations governing grade crossings.

The signal system regulation 49 CFR Part 236 governs signal installations. However, there are no requirements concerning grade crossing protection systems, including any requirements for specific protection systems to be installed in specific circumstances.

There is a general obligation laid on the FRA and the Federal Highway Administration to work on initiatives to reduce grade crossing accidents and incidents. This has taken the form of research, financial assistance for grade crossing elimination, improvements of grade crossings, and public education programs such as Operation Lifesaver. In general, most current programs of grade crossing research are aimed at reducing the incidence of collisions between freight trains and highway vehicles. One outcome of the research has been recognition of the need to make freight trains more conspicuous to highway users at night, hence the consideration of reflecting stripes on cars and crossing markers on both sides of the tracks.

### Other U.S. Standards and Practices

Grade crossings are permitted in the U.S. at rail speeds up to a maximum of 175 km/h (110 mph). In practice, the only 175 km/h (110 mph) operations over grade crossings are on the limited stretches on the New York-Albany line with Amtrak's Turbo trains. All grade crossings on the Northeast Corridor where speed may exceed 160 km/h (100 mph) have been eliminated. Most Amtrak trains operate at a maximum speed of 145 km/h (90 mph), where cab signals or ATC are installed. Speeds of 79-90 mph across grade crossings are common. The 1991 Rail-Highway Crossing Accident/Incident and Inventory Bulletin indicates that there are 538 crossings where the timetable speed is between 81 and 90 mph.

AAR signal system standards and the Federal Highway Administration (FHWA) Manual on Uniform Traffic Control Devices provide standards for grade crossing warning systems, but do not specify criteria on where specific types of systems should be installed. An FRA publication, the Rail-Highway Crossing Resource Allocation Procedure Users Guide, Third Edition (DOT/FRA/05-87/10), provides guidelines on how to calculate the safety benefits of upgrading grade crossing warning systems.

## **3. Foreign Standards and Practices**

European practice is governed by three UIC codes:

- 760 OR Level crossings: Road signs and signals
- 761 Technical directives for the automatic operation of or warning to level crossings
- 762 Safety measures to be taken at level crossings situated on high speed lines

These codes recommend that at least half-barriers, flashing lights, and bells be installed on high speed lines. The crossing systems should have provisions to sense train speed and provide an approximately constant warning time to road traffic. The very short duration barrier opening that occurs when a second train approaches the crossing from the opposite direction shortly after the first train has passed should be prevented. Operation at up to 200 km/h (125 mph) over grade crossings on conventional lines is permitted.

This can be compared with the U.S. situation where there are very few locations where speed over a rail-highway at-grade crossing exceeds 145-160 km/h (90-100 mph).

Canadian regulations currently limit the maximum speed over at-grade highway crossings to 153 km/h (95 mph).

#### **4. Specific HSGGT Practices**

##### **Canada**

Maximum speeds in passenger service in Canada are 190 km/h (95 mph), the maximum allowable over grade crossings under Canadian regulations. This has been a key obstacle to higher speeds, since lines over which higher speeds would be commercially attractive (such as Montreal-Toronto) have many grade crossings.

##### **Great Britain**

In the U.K. there has been a deliberate program to eliminate crossings on lines operated at speeds exceeding 160 km/h (100 mph) and on electrified main lines. However, there appears to be no mandatory rule or policy concerning this, and a small number of crossings may remain in 200 km/h (125 mph) territory. Both high speed and conventional trains operate over grade crossings at 160 km/h (100 mph) or less at many locations.

##### **Sweden**

The introduction of 200 km/h (125 mph) services in Sweden with the X2000 train has prompted improvements to at-grade highway crossing protection on higher speed lines. There are many crossings on the X2000 routes and elimination or grade-separation of all crossings is not an economic option. Where crossing elimination or grade-separation cannot be justified, high speed grade crossings in Sweden are equipped with sensors to detect whether the gates have closed at the correct time and inductive sensors to detect the presence of a vehicle on the tracks. The sensors are linked to the signal and ATP system, and will stop the train if a gate malfunctions or obstruction is detected. This system does not provide absolute protection-it is still possible for an errant road vehicle to crash through the gates into the path of an approaching train, and the vehicle detection system may not be totally reliable, but grade crossing collision risk is reduced.

### 3.2.4 Brake Installation and Performance

#### 1. Introduction and Summary

Preserving the ability to stop within a specified distance at all times is absolutely critical to the safety of guided transportation systems. This has been recognized from the earliest times, and laws regarding brake system performance were among the earliest forms of railroad safety regulation.

These requirements typically address the following aspects of brake operation:

- Brakes must be "fail-safe." Generally, this means that no malfunction in the system that controls or supplies the power for the application of brakes on a train shall lead to a loss of braking capability. Normally, systems are arranged such that any malfunction (such as an air leak in the train pipe of a pneumatic brake) will lead to a brake application on all vehicles in the train. It also means that individual brakes must fail "off" to avoid the dangers of an individual brake that is stuck "on" in an otherwise unbraked train. A stuck brake could cause severe overheating and fracture of a wheel tread or disc friction brake.
- System design and operating procedures must be such that a train cannot start moving unless adequate braking power is available. Braking regulations typically require that between 80 and 90% of the brakes on a train are functioning. This capability must be retained through a reasonable sequence of repeated brake applications.
- Pre-departure brake tests must be made to ensure that the brakes are working on all vehicles of the train. Such tests also must be made whenever the consist is changed, for example, when vehicles are added or removed. Failure to make the necessary air pipe and electrical connections between vehicles is probably the most common cause of brake-related accidents. The brakes on the unconnected vehicles are rendered completely inoperative when the connections are not made, reducing brake power, extending stopping distances, and overloading operative brakes.
- Stopping distance performance must be compatible with the requirements of the signal and train control system. Traditionally, this condition is satisfied by basing headways and signal spacing on the proven performance of the braking systems, usually assuming 10 to 15% of individual brakes are inoperative.

The brake system design requirements of conventional railways are well satisfied by the traditional air brake. The air brake uses compressed air both as the control system and as the source of braking force. For control, a pipe running the length of the train is maintained at a working pressure (typically 550-820 kN/m<sup>2</sup> (80-120 psi)). Any reduction in this pressure is sensed by a control valve on each vehicle, which then admits compressed air from a reservoir to the brake cylinder, applying brake force to the wheel or the disc of a disc brake. Thus, the brake will be applied in case of significant leakage in the train air pipe, or accidental parting of the train. The brake can only be released by restoring full pressure in the control pipe. Pressure cannot be attained until the braking air reservoirs on each vehicle are recharged, ensuring that brake power is always available. Numerous refinements, including electric control, have been added to the basic air brake to improve responsiveness and controllability, but the basic principles

remain unchanged, and pneumatic control is retained as a back-up with electro-pneumatic systems.

An additional safety feature, almost universally used in wheel-on-rail passenger vehicles, is the wheel-slide protection (WSP) system. These systems sense incipient wheel slide between wheel and rail, and automatically reduce braking effort until the slip is eliminated. This process maximizes the use of wheel-rail adhesion and reduces the incidence of wheel damage due to skidding.

The principles of the electro-pneumatic brake system with wheel-slide protection are similar in the U.S. and overseas, but there are a number of differences in detail, for example, in operating pressures.

Conventional railway braking systems are applied to wheel-on-rail HSGGT systems. The very large amount of energy to be dissipated in a high speed stop, however, means that friction braking is blended with electrical non-contacting dynamic, regenerative or eddy current brake systems to achieve the desired performance without excessive friction brake wear and maintenance. The German ICE and the Swedish X2000 both have been fitted with magnetic track brakes for emergency braking. These brakes help the X2000 to stop before reaching a defective or obstructed at-grade highway crossing equipped with the warning systems described in Section 3.2.3. Non-contacting eddy-current track brakes are also under consideration for the ICE.

Maglev systems rely principally on electrical braking systems at high speed, with skid brakes reserved for low speed or possible emergency use. Electrodynamic maglev systems equipped with landing wheels may use friction brakes at low speeds. In both wheel-on-rail and maglev electrical braking systems, braking safety performance is achieved by equipping the train with multiple, independent braking units. These are arranged so that a systemic failure (such as a loss of power supply) cannot affect the operation of all brakes on the train. Very high reliability is required for the control systems used for electrical brakes, achieved through redundant and/or fault tolerant design.

One train design, the Spanish Talgo, uses hydraulically actuated friction brakes, but retains conventional pneumatic control. Hydraulic actuation has not normally been acceptable to existing U.S. passenger train operators because of reliability concerns, although there is no specific prohibition in the published rules and standards.

There are no significant ways in which the U.S. operating environment alters the risk of brake failures as compared with the European environment. One possible issue is that U.S. conventional railroad track, other than on new high speed lines, is likely to be of lower quality than equivalent track in Europe. This means that the shock and vibration environment of truck and axle-mounted equipment will be more severe in the U.S., and mechanical brake arrangements developed elsewhere may need modification to tolerate this environment.

Accidents attributed to inadequate design and manufacture of brake systems are rare. Accidents due to human error related to braking, especially failure to ensure that all brakes on a train are operating, are more common. Automatic safeguards against this type of error are desirable, and



can be provided by the automatic condition monitoring systems being introduced on the most recent train designs (e.g., the TORNAD system on the TGV Atlantique).

## **2. U.S. Regulations, Standards, and Practices**

### FRA Regulations

Brake requirements are specified in Part 232 of the CFR Title 49.

Most of this part is concerned with testing, inspection, and maintenance of conventional railroad air brakes used in freight and passenger train operations.

Key requirements are:

- A minimum of 85 % of all cars in a train must have operable brakes.
- Brakes must be capable of operating in emergency mode at all times, even during a service brake application.
- Both pre-departure and running brake tests must be made at the beginning of a trip, after any change to the train's consist, and at intermediate inspection points not more than 1,000 miles apart.

### Other U.S. Standards and Practices

The Association of American Railroads provides passenger car brake standards, but many of these are out of date and do not reflect current high speed passenger car practice.

Amtrak and other passenger operators customarily require use of the 26CS-1 electro-pneumatic brake control system, as supplied by the major U.S. brake systems manufacturers. A wheel slide protection system is also required.

Recently purchased Amtrak intercity passenger cars have two disc brakes per axle, plus a wheel tread friction brake to meet the most demanding Northeast Corridor braking requirements. Electrical dynamic braking by the locomotive is used to reduce friction brake wear, but is not relied upon for achieving specified stopping distances.

## **3. Foreign Standards and Practices**

A series of UIC codes (540-546), summarized in Table 3-5, specify construction and performance requirements for conventional railroad air brakes. These codes are formulated primarily to ensure compatibility between vehicles belonging to different owners.

An emergency braking rate of  $0.85 \text{ m/sec}^2$  (1.9 mph/sec) is required of vehicles approved for operation at 200 km/h (125 mph). Two disc brakes per axle are required instead of brakes acting on the wheel treads. In contrast, Amtrak requires a rate of  $1.12 \text{ m/sec}^2$  (2.5 mph/sec) in Northeast Corridor service.

**Table 3-5. UIC Codes for Brake Installation and Performance**

UIC-410	Calculation of passenger weight of baggage
UIC-540	Air brakes for freight & passenger trains
UIC-541-03	Brakes - Regulations concerning the manufacture of different brake parts - driver's brake value
UIC-541-05 OR	Regulations concerning construction of various brake components: wheel slip prevention equipment
UIC-541-1	Brakes - Regulations concerning the construction of various brake components
UIC-541-5,0	Electropneumatic brakes for passenger and freight trains: minimum requirements
UIC-541-6,0	Electropneumatic brakes: test programs for passenger & freight trains
UIC-543 OR	Brakes - Regulations relative to the equipment and use of vehicles (air, screw, lever)
UIC-544-1,0	Brakes: braking power
UIC-544-2	Conditions to be observed by the dynamic brake of locomotives and motor coaches so that extra braking effort produced can be taken into account for the calculation of brake-weight
UIC-546 OR	High power brakes for passenger trains
UIC-547	Air brakes - standard program of tests

Brake design and performance for speeds above 200 km/h (125 mph) is currently the responsibility of the individual operator. There are no established standards and practices. Components usually conform to UIC requirements.

Table 3-6 provides a summary description of high speed train brake types, including the advantages and disadvantages of each.

#### **4. Specific HSGGT Practices**

Table 3-7 provides summary descriptions of the braking systems used for specific wheel-on-rail and maglev systems. The common themes in braking system selection among different HSGGT systems are as follows:

- Disc braking - with the discs mounted on the axle, the wheels, or some part of the mechanical transmission of powered vehicles - is the most broadly used system on conventional wheel-on-rail trains. With pneumatic actuation, these are highly reliable brakes with a moderately high energy absorbing capacity.
- The electro-pneumatic control system is universally used for wheel-on-rail trains. In this system, braking commands are transmitted electrically to the brake controller on each vehicle, which in turn controls the air pressure in the brake actuator. Many systems now embody microprocessor control of brake commands, particularly where there is blending of the air brake with other brake types in the same train to achieve a specific retardation. Blending is the process by which friction braking is controlled to achieve a desired constant braking rate in combination with an electrical dynamic or eddy current brake. All systems retain the capability of pure pneumatic control as a back-up for electrical failures.
- Some wheel-on-rail systems (e.g., the TGV-PSE) have an auxiliary brake acting on the wheel tread. The primary purpose of this brake is to "scrub" the tread to remove contaminants, and thus improve adhesion and reduce the risk of the train not being detected by track circuits.

The tread brake also can contribute to the overall braking effort, and can be used as a parking brake. However, high energy tread braking is avoided because of the risk of wheel damage due to excessive heating.

- All wheel-on-rail systems embody wheel slide protection systems to maximize the use of available adhesion and avoid wheel damage through skidding.
- Eddy current brakes are proposed or under consideration on some HSGGT systems, most notably as an emergency brake on the Transrapid Maglev system and as a supplemental brake to reduce stopping distance in the German ICE train. Eddy current brakes work by generating an alternating electromagnetic field and eddy currents in a passive "rotor." The "rotor" is usually the rail (or the steel reaction rail of a maglev vehicle). The three main points about eddy-current brakes are:

**Table 3-6. Description of Principal Brake Types**

Energy Absorption	Type	Description	Actuation	Application	Advantage/Disadvantage
Friction	Tread brake (or block brake)	Brake shoes acting on wheel	Compressed air (except for Tread panish Talgo which hydraulic)	Often used in combination with ison-friction brake., particularly for emergency application, and as main brake on unpowered cars	Adv: • Independent of electric power supply. Disadv: • Wear and tear  • Limited total energy capacity
	Disc brake (wheel, axle or transmission-mountd)	Calipers gripping disc			
	Electromagnetic track brake	Brake shoe (magnet) clamp to top of rail	Electric power applied to electromagnet	Emergency brake on some high-speed trai (ICE, X2000)	Adv: • Independent of wheel-rail adhesion Disadv: • Wear and tear • Requires reliable power supply
Electric Resistance (rotary motor)	Regenerative	Electric power from motor fed back into power source	<ul style="list-style-type: none"> <li>• Through electrical controls</li> <li>• Needs separte power supply for excitation</li> </ul>	Used in powered vehicles. Back-up power supply required sometime.	Adv: • Save energy in regeneration • Less wear and tear • Does not heat rail Disadv: • Complex • Requires reliable/or fault-tolerant power supply if used as safety brake.
	Basic (or rheostatic)	Electric power from motor fed to resistors			
Electromagnetic Field	Rotary eddy -current	Generates eddy current in disk, absorbing energy	<ul style="list-style-type: none"> <li>• Electrical controls</li> <li>• Power source required fo excitation</li> </ul>	Used to supplement friction rbrakes on all vehicle types	Adv: • No wear and tear • Effective at high speed • Independent of adhesion (linear) Disadv: • Can cause heat build-up  in rails causing buckling if applied frequently in same locations (linear variant) • Les effective at low
	Linear eddy -current	Same as rotary except that currents are generated in rail			
Electrical Resistance (linear motor)	Reversed linear electric motor	Motor acts as generator, poving electric power to resistor or back into power source	<ul style="list-style-type: none"> <li>• Electrical controls used</li> <li>• Separate power supply needed for excitation</li> </ul>	Used with linear motor powered systems (e.g.. Maglev)	Adv: • No wear and tear • Saves energy in regenerative version Disadv: • Les effective at low speed • Requires reliable or fault-tolerant power supply if used as safety brake

**Table 3-7. Overview of HSGGT Brake Systems**

Train/Line/Speed	Application by Vehicle Type	Brake Systems	Comments	Actuation	Cotro System
German Maglev Dedicated 300 km/h	Service and emergency	Linear motor reverse		Electric power supply to guideway	Microprocessor (service and emergency)
	Emergency (after LIM failure)	Eddy Current + guideway skids (low speed)		Multiple independent power supplies on vehicle	
German ICE (260 km/h) • Mixed on both existing and new construction lines	Power Car	Disc brake - 2 or 3 discs per axle Regenerative	UIC compatible	pneumatic and electrical (eddy current and regenerative systems)	Microprocessor controlled pneumatic
	Passenger car	2 magnetic track brakes per truck. Eddy current alternative under consideration. 3 axle-mounted discs per trailer axle	UIC compatible		
French (300 km/h) TGV-PSE and Atlantique • Dedicated on new lines  • Mixed on existing lines	Power car	Rheostatic brake + tread blending in at low speed	Developed new brake disc to exert 70% higher braking force for TGV-R.	Pneumatic and electrical	<ul style="list-style-type: none"> <li>• Electro-pneumatic, microprocessor controlled monitoring and blending</li> <li>• Automatic monitoring of operating status of each brake</li> </ul>
	Passenger car	Disc brakes 4 discs per axle and single tread brake (on PSE cars only)	Developed improved wheel slide protection		
Sweden (210 km/h) existing line mixed traffic only	Power car	Regenerative + disc + tread		Pneumatic and electrical	Electro-pneumatic Electronic wheel slip detection and correction
	Passenger car	2 axle-mounted discs per axle + 2 magnetic track brakes per truck			
British (200 km/h) existing line mixed traffic only	Power car	Rheostatic + tread		Pneumatic	Electro-pneumatic
	Passenger car	Wheel-mounted discs on each wheel			
Japan, Shinkansen	M.U. train most axles powered	Wheel-mounted discs per axle + rheostatic brake for all powered axles		Pneumatic and electrical	

- Electric power is required to excite the brake. Thus, multiple independent power sources for the brake on a train are required to provide adequate redundancy if an eddy-current brake is used as a primary brake.
- It is ineffective at low speed, below 30-50 km/h (20-30 mph).
- Use of a railroad rail as the heat sink for eddy current brake in regular operation is considered questionable. This can lead to excessive heating of the rail and an increased risk of track buckling instability.
- Regenerative or rheostatic electrical braking is widely used on powered vehicles. The traction motors are used as generators that produce power to be absorbed by onboard resistors or to be returned to the power supply. Electrical braking systems require a power supply for excitation, and multiple power sources are required if the electrical brake is relied upon as a primary brake. Otherwise, braking performance must be ensured by other braking systems on the train. An electrical brake lacking a redundant power supply reduces wear and energy consumption, but cannot be relied upon to achieve shorter stopping distances. Note that linear motor braking as used on the Transrapid Maglev system is functionally identical to conventional railroad vehicle regenerative and resistance braking with rotary motors.
- Magnetic track brakes have been fitted as emergency brakes on some vehicle types, most notably the Swedish X2000, the German ICE, and some conventional 200 km/h (125 mph) rail vehicles in Germany.

### **3.2.5 Operating and Maintenance Staff Qualifications and Training**

#### **1. Introduction and Summary**

Errors by operating staff, both train operators and those responsible for providing operating instructions to these operators such as dispatchers and signalmen, are historically a significant cause of collisions and other accidents. These errors include failure to obey signal indications, in adherence to operating rules and instructions, and operating at speeds exceeding that permitted for the location or type of train. Ensuring that operating staff are properly qualified and trained is an important factor in the prevention of such accidents. This requirement is always present, even on largely automated systems, since there will always be occasions when the manual control of train movement is required, for example following malfunctions of the automated system.

Errors and omissions by personnel responsible for inspection and maintenance of vehicles, and guideway, and control systems are a contributing cause in many accidents attributed to a vehicle or guideway defect. Either an unsafe condition was not detected in inspection, or improper maintenance procedures were used which led to an unsafe condition. As with operating staff, ensuring that maintenance and inspection staff are properly qualified and trained is an important factor in preventing errors and omissions that could lead to an accident.

Published information available on the subject of rail operations and maintenance staff training and qualifications is limited, since this is primarily the internal responsibility of individual railways. Some information is provided below on British, French, and Japanese practices.

These practices vary considerably. In France, the SNCF regards the TGV as a new piece of equipment, and operator training is brief. However, the SNCF has long experience of high speed operations on conventional lines, and all TGV operators are senior employees. In Japan, the Shinkansen is regarded as a separate system, substantially different from the rest of the rail system, for which ground-up training is required. The use of simulators for operator training is growing in all countries.

New maintenance and inspection facilities and equipment are usually provided for new high-speed vehicles and infrastructure. It is customary to provide training in the specifics of maintenance and inspection for the new facilities and vehicles.

## **2. U.S. Regulations, Standards, and Practices**

### FRA Regulations

Following the disastrous Chase, Maryland collision in late 1987 (described in Section 2.4), the FRA has introduced new regulations (49 CFR Part 240) for the federal licensing of railroad engineers, accompanied by more formal requirements for training and requalification. Otherwise, there is a general requirement in 49 CFR Part 217 for railroads to instruct their employees in operating practices, and to conduct periodic tests to monitor and ensure compliance with the operating rules. A description of the nature of these tests and a testing schedule must be filed with the FRA.

FRA safety regulations also require that conventional railroad track, locomotive, and car inspectors have appropriate training and experience. However, there are no detailed requirements.

## **3. Foreign Standards and Practices**

UIC Code 966 "Measures Intended to Promote Safety Consciousness in Staff" provides requirements for training and other methods of promoting safety awareness such as meetings and awards for accident-free operation. Otherwise, there are no international standards in this field.

## **4. Specific HSGGT Practices**

Information is relatively sketchy in the sources available for use in this study. However, some information has been located giving brief descriptions of practice on the SNCF/TGV, Japanese Shinkansen, and British Rail.

### **France**

Train crews for high speed TGV trains are recruited from senior employees who are already qualified for conventional-speed intercity trains. Training of a TGV engineer takes three weeks, involving familiarization with TGV trains, instruction in special operating rules applying to the high speed line, and familiarization with the specific features of the line over which they will be operating. The training concludes with theoretical, practical, and psychological tests. A relatively large number of engineers are trained to drive the TGV, and each will typically drive both TGVs and conventional trains. There is no separate force of TGV engineers.

The SNCF is making a broader effort to improve training techniques for all engineers through expanded use of simulators, computer-aided teaching systems, and other methods, in response to safety concerns raised by the serious accidents in recent years.

The SNCF has built dedicated maintenance facilities for TGV trains, and the staff of these facilities are trained in the special features of the maintenance equipment and the trains themselves. Special equipment and procedures have been developed for track and signal and train control system maintenance, together with corresponding staff training. Customarily, all staff performing inspection and maintenance for the high-speed systems have prior qualifications and experience in conventional railroad systems.

## **Japan**

JNR operates an extensive system of schools for craft and management jobs. One of these is a "conversion course" to train narrow-gauge engineers to be Shinkansen motormen. This takes four months. Training of personnel who lack previous engineering experience takes 11 months. Courses in other crafts (track maintenance, signal maintenance, etc.) run typically from one to three months, depending on the individual's experience.

JNR also uses various aptitude and psychological tests to judge the suitability of individuals for operating jobs. Correlations between test scores and accidents have been established, and JNR continues to develop and refine these tests.

## **Great Britain**

BR has been developing training procedures and aptitude tests for train operating personnel. Junior engineers receive a total of about five weeks' classroom instruction and 10 weeks of supervised operating experience before qualifying to go "solo." They will typically then spend several years in less demanding duties before accumulating enough experience and seniority to operate high speed trains. Simulators are now being widely used as an aid to training and to assess operator capabilities. Personality and aptitude tests form part of the selection procedure for aspiring operators.

### **3.2.6 Operating Rules and Practices**

#### **1. Introduction and Summary**

Guided transportation systems need to develop and maintain a comprehensive set of operating rules and instructions for specific locations and types of equipment. Operating rules typically cover all procedures needed for the management of vehicle movements, including rules for the response to signal indications, communications between operators and dispatchers, and rules for employee conduct while at work. Separate documents such as timetables provide equipment- and location-specific operating instructions and speed limits, requirements concerning crew size, maximum shift length and rest periods, and emergency response procedures. Good operating rules and procedures reduce the risk of collisions due to train crew or dispatcher errors. In case of an emergency, operating personnel will be ready to implement an appropriate response to minimize casualties.



Operator error is one of the most significant causes of train accidents. Therefore, establishing appropriate operating rules and practices for an HSGGT system will be very important, even if a sophisticated ATP system is used to supervise operator actions. Procedures to be followed after a malfunction of an automated system are particularly important.

## **2. U.S. Regulations, Standards, and Practices**

### FRA Regulations

Under 49 CFR Part 217, railroads must file a copy of their current operating rules, timetables, and other instructions with the FRA. They also must file their programs of tests and inspections to evaluate compliance with the operating rules, and disclose employee instruction, keep records of the results, and submit these in an annual report to the FRA. In particular, they must report occasions when employees have been found in violation of "Rule G" prohibiting working under the influence of alcohol or drugs.

49 CFR Part 218 lays down the requirements for protecting vehicles on which maintenance personnel are working by a blue signal or flag or other means. Another section of the same part provides regulations for the protection of stationary equipment by torpedoes, fuses or flags. Torpedoes are small explosive devices placed on the rail, that produce a warning sound signal when run over by a wheel. Fuses are warning flares.

49 CFR Part 236, covering signal and train control systems, specifies that a block signal system is required for operations at 97 km/h (60 mph) and above, and a cab signal system or ATC for operations at 129 km/h (80 mph) and above.

49 CFR Part 228 limits the maximum continuous hours on duty of train crew, dispatchers, and signal inspection and maintenance personnel to 12 hours in most cases. A maximum off-duty time of 8 hours is required, increasing to 10 hours following a 12-hour shift.

### Other U.S. Standards and Practices

Most U.S. railroads, at a minimum, have a code of operating rules which includes all the rules contained in the "Standard Code of Operating Rules" published by the AAR.

Amtrak and the commuter railroads operating in the Northeast Corridor between Washington and Boston have formed the "Northeast Operating Rules Advisory Committee" (NORAC) to develop operating rules appropriate for higher speed and high density passenger train operations. The resulting NORAC rules are applied in the corridor and certain connecting lines.

All railroads also have a set of location-specific operating rules embodied in their timetables and other operating instructions. These typically concern speed limits, where particular types of equipment can operate, and similar matters.

## **3. Foreign Standards and Practices**

Three UIC codes cover specific aspects of operating rules and operating safety:

- Code 734 recommends that automatic train control be used at speeds above 140/160 km/h (87-100 mph) and that cab signals and automatic train protection systems be used at speeds over 200 km/h (125 mph).
- Code 965 requires the clear delineation of safety responsibility for staff working on the track, and that a proper look-out be maintained. The processes of obtaining permission to work and the interface with the train control systems are not discussed.
- Code 966 discusses the contents of safety programs designed to keep employees aware of safety matters, including training, testing, and media presentations.

#### **4. Specific HSGGT Requirements**

Rules documents for individual high speed and conventional operations on foreign railroads were not available at the time of preparation of this report. However, the operating rules used by the SNCF for high speed TGV operations have been made available to VNTSC for future study.

### **3.3 ACCIDENT SURVIVABILITY**

#### **3.3.1 Overall Vehicle Structure**

##### **1. Introduction and Summary**

Casualties to vehicle occupants in collisions with other vehicles or large obstructions on the guideway or other accidents are primarily caused by gross crushing of the space occupied by passengers or crew, penetration of the occupant space, or impacts between occupants and interior surfaces during the sudden acceleration of the vehicle at the time of collision. To minimize casualties, overall vehicle structures should be designed to minimize the risk of crushing and penetration of occupant spaces in an accident. The force-deformation characteristics of the vehicle structure affect the magnitude and duration of the acceleration pulse applied during an accident. The characteristics of the connection between vehicles or vehicle-sections affects the risk of override, jackknifing, or rollover in an accident. Connections that resist relative vertical shear, roll, and lateral yaw between vehicles reduce the risk of override, jackknifing, and rollover. Such connections help vehicles stay upright, coupled, and in line in a collision.

Conventional railroad car structural performance is usually specified in terms of an end load or "buff strength" that the vehicle shall withstand without permanent deformation. Other minimum loads included in conventional requirements include corner loads and collision-post loads at a specified height above the coupler or floor. Coupler shear strength, anticlimber, buffer, and truck attachment strength requirements address the need to resist override, jackknifing, and rollover. No formal structural requirements have yet been developed for unconventional systems such as Maglev operating on segregated tracks, although accident scenarios are considered in the structural design. Buff-strength and other requirements have developed empirically, from experience of vehicle performance in accidents, and appear to provide reasonable protection for vehicle occupants under conventional speeds and operating conditions.

UIC structural strength requirements, universally followed in Europe for conventional wheel-on-rail trains, are significantly lower than FRA/AAR strength requirements applicable to North

American railroad cars. The UIC requirements also lack a requirement for minimum vertical coupler or anti-climber strength, equivalent to that specified in the FRA/AAR requirements.

European high-speed trains conforming to UIC requirements for structural strength often have features that further enhance crashworthiness. For example, the TGV incorporates crushable, energy-absorbing structures in the power car nose. The articulated joint between cars provides substantial anti-override and roll-over constraints, beyond UIC requirements.

## 2. U.S. Regulations, Standards, and Practices

### FRA Regulations

CFR Title 49 Part 229.141. Structural strength regulations, applicable (on strict interpretation) to Multiple Unit (MU) locomotives only. The key provisions are given in the following table and illustrated in Figure 3-6.

	Train Empty Weight Exceeding 272 tonnes (600,000 lb)		Train Empty Weight Below 272 tonnes (600,000 lb)	
	Metric (kN)	English (lb)	Metric (kN)	English (lb)
Buff strength in line with coupler	3560	800,000	1780	400,000
Collision post shear strength (each of two)	1334	300,000	890	200,000
Truck-to-body shear strength	1112	250,000	1112	250,000
Anti-climbing arrangement vertical strength	445	100,000	334	75,000
Vertical coupler strength	445	100,000	334	75,000

These loads must be sustained without deformation of the car structure, except for collision-post and truck-to-body shear loads, which must be sustained without total failure.

### Other U.S. Standards and Practices

The Association of American Railroads (AAR) requirements apply to passenger cars operated in trains exceeding 27,200 kg (600,000 lb.). They are identical to the FRA standards for MU locomotives.

North America (AAR/FRA), for trains exceeding 272 tonnes (600,000 lb) empty mass

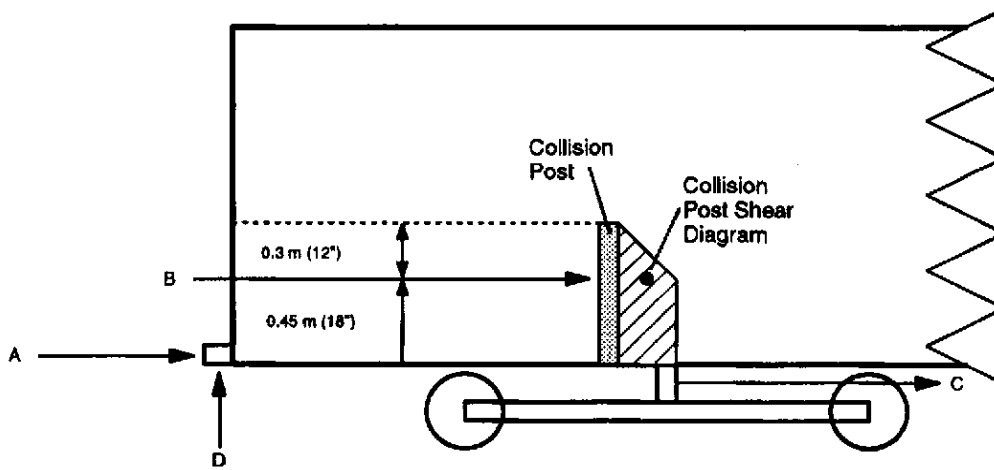

A	Buff	3560 kN (800,000 lb.)
B	Collision Post (each of two)	1334 kN (300,000 lb.)
C	Truck/Body	1112 kN (250,000 lb.)
D	Coupler, etc.	445 kN (100,000 lb.)

Europe (UIC Code 566)

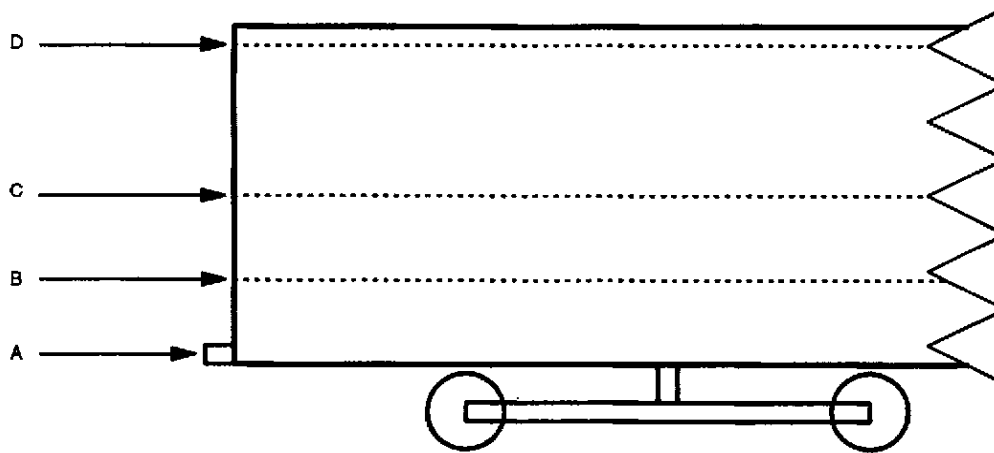

A	Buff	2000 kN (449,000 lb.)	In addition there is a diagonal load of 500 kN (112,000 lb.) at buffer level.
B	350 mm (14" in) Above A	400 kN (90,000 lb.)	
C	Center Rail Level	300 kN (67,000 lb.)	
D	Cant Rail Level	300 kN (67,000 lb.)	

**Figure 3-6. Comparison of North American and European Car Body Strength Requirements**



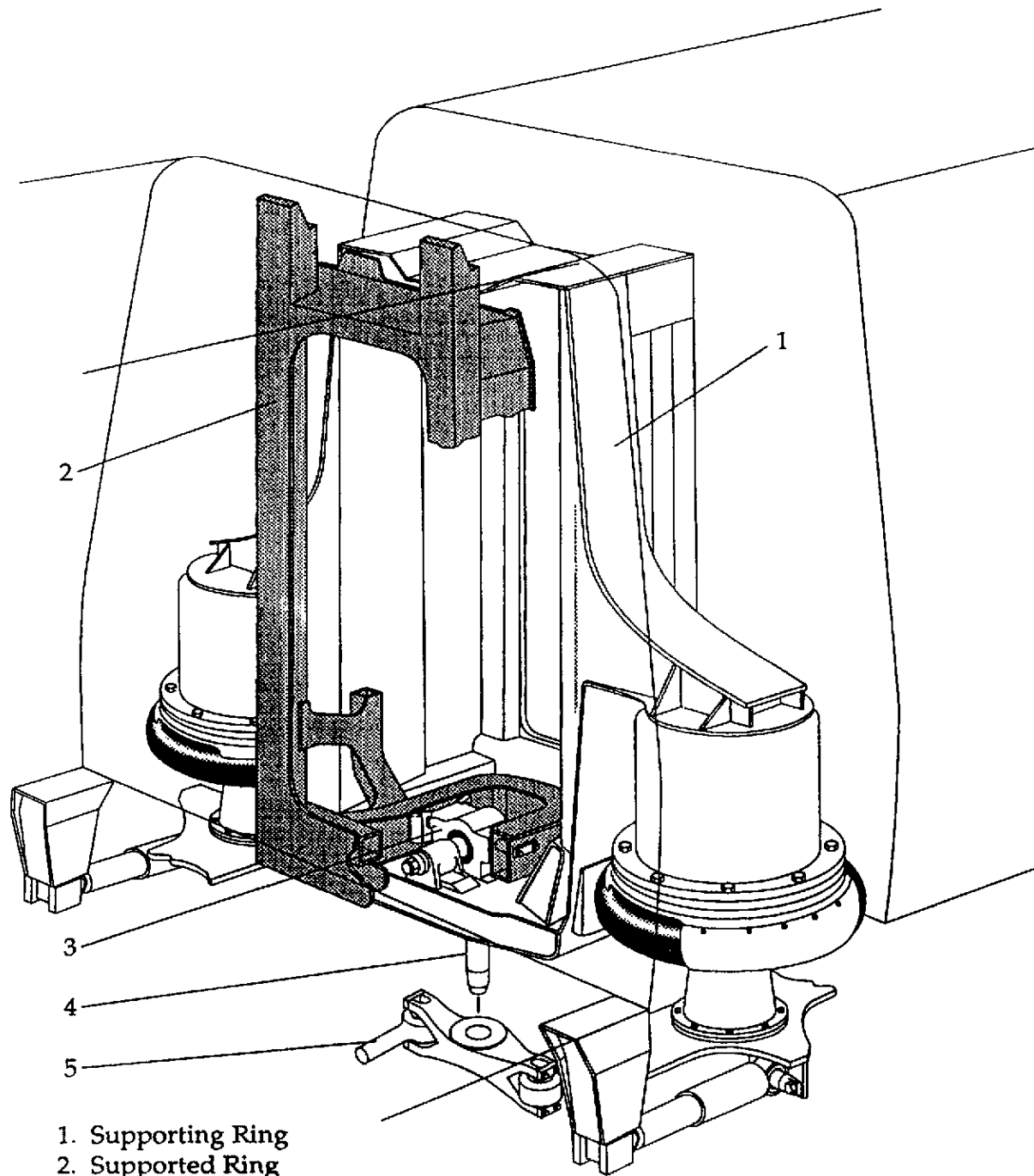

- 1. Supporting Ring
- 2. Supported Ring
- 3. Articulation Joint
- 4. Truck Center Pin
- 5. Connection to Truck Frame

Source: GEC-Alsthom

**Figure 3-7. Articulation Arrangement of the TGV Atlantique**

## 4. Specific HSGGT Practices

All the European wheel-on-rail trains are designed to meet or exceed UIC Code 566. The principal factors that affect accident survivability performance are whether the end vehicles of the train contain passenger accommodations; whether there is any provision for protective, crushable structure; the materials used; and any special features of the inter-vehicle connection. Table 3-8 summarizes the principal features of selected vehicles or trains. Many of the features of these consists and individual vehicles follow from considerations other than crashworthiness. Those features specifically selected for accident survivability reasons include:

- Use of a crushable, energy-absorbing nose cone on the French TGV, designed to limit damage to the train in minor collisions. This feature is shown in the illustration of the TGV Atlantique power car arrangement, Figure 3-8.
- The articulation joint between TGV passenger cars provides substantial resistance to override, rollover, and jackknifing forces. This feature contributed to the good performance of a TGV train set in a collision with an 80 tonne (88 ton) piece of machinery in a grade crossing collision. The train stayed upright and in-line, and major structural damage was confined to the leading power car.
- The articulation joint of the Talgo is designed to resist roll-over, jackknifing, and override forces generated in collisions.
- The Swedish X2000 push-pull train uses a ballasted cab car having the same structural design as the locomotive with regard to impact protection. Both locomotive and cab-car cabs are required to withstand impacts at 200 km/h (125 mph) at a point 1.8m (5.9 ft) above rail with the following objects:
  - a) a 5 tonne (5.5 ton) cylinder of 2m (6.56 ft) diameter
  - b) a 10 tonne (11 ton) cylinder of 4m (13.12 ft) diameter
- Use of unpowered cab cars with passenger accommodation is forbidden in the U.K. at speeds over 160 km/h (100 mph) because of their vulnerability in an accident. Thus, the IC225 intercity train has a locomotive at one end and a cab/baggage car at the other. Cab cars must also have a minimum axleload of 120 KN (27000 lb) and be equipped with a cow-catcher capable of sustaining a 60 tonne (66 ton) impact.

Structural requirements specific to operator's cabs are discussed in the following Section 3.3.2.

### 3.3.2 Operators' Cab Crashworthiness and Safety

#### 1. Introduction and Summary

Since operators' cabs are at the head-end of a vehicle or train, they are especially vulnerable to damage in collisions with another vehicle or train on the same track, or with major obstructions

**Table 3-8. Accident Survivability Features of Selected Foreign High-Speed Trains**

HSGGT System	Consist	Materials		Inter-vehicle Coamectims	Other Features
		Power Car	Passenger Car		
Transrapid Maglev German	Vehicle made up of several separate vehicle units	Not applicable	Welded aluminum and composites	Believed to be ball joint type, allowing limited rotational freedom in all planes	Not designed to "railway" collision standards (UIC Code 566, etc.)
TGV France	Power car + 8-10 pass. cars + power car Two train sets may be coupled	Welded carbon steel	Welded carbon steel Alumiumm (bilevel version)	Articulated consist: univernal joint and other connections, allowing limited rotational movements in all planes Special design center coupler between train-sets	Crushable, energy absorbing nose structure at train ends. Crushable ends on intermediate cars in future models.
ICE Germany	Power car + 10-14 pass. cars + power car	Welded carbon steel	Welded aluminum extrusions	Transit-style center coupler	None
Shinkansen Japan	Multiple-unit train. Most ars powered, all occupied	Not applicable	Welded carbon steel	Center coupler*	Do not follow UIC Code 566. However, believed to be at least as strong as European trains
IC 225 UK	Power car + 10 pass. cars + cab/baggage car	Welded carbon steel	Welded carbon steel	Center coupler*	Cab/baggage car, minimum weight 48 tonnes. "Cow-catcher" used
ETR 450 Italy	Multiple unit train. Most cars powered, all occupied	Not applicable	Welded aluminum extrusions	Center coupler*	Active tilt system
Talgo Spain	Passenger car consist only. No locomotive or power car	Not applicable	Welded aluminum extrusions	Articulated consist: ball joint allowing limited rotational movement in all planes	Passive tilt system
X2000 Sweden	Power car + 4 pass. car + cab/pass. car	Welded stainless steel	Welded stainless teel	Rigid bar center coupler with draft gear	Active tilt system

\*Details not available. Current practice with high speed wheel-on-rail trains transit-style or bolted rigid bar center couplers incorporating air and electrical connections.



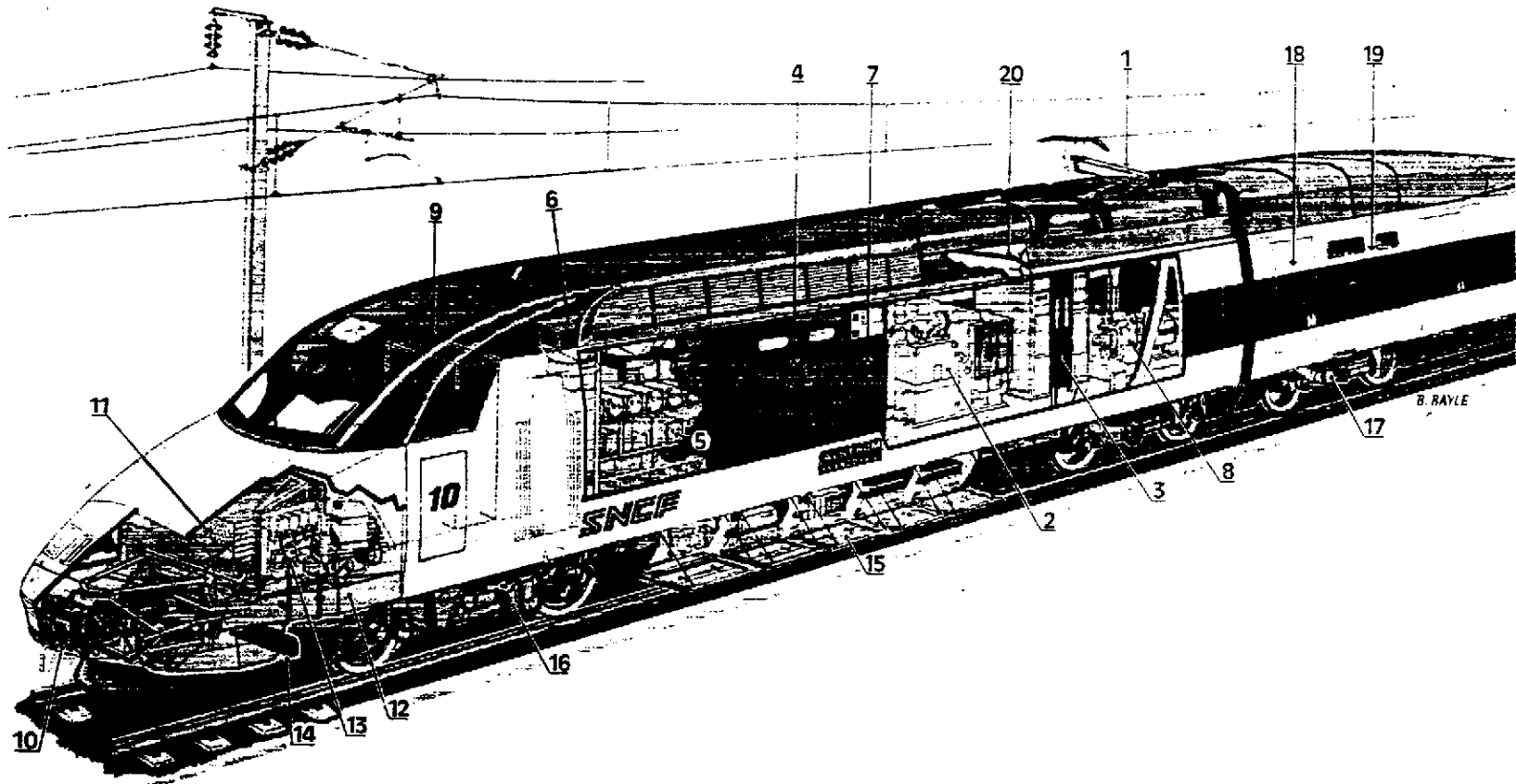

- 1 - SINGLE ARM PANTOGRAPH
- 2 - MAIN TRANSFORMER
- 3 - CIRCUIT BREAKER, LINE FILTER
- 4 - MICROPROCESSOR-CONTROLLED TRACTION MOTOR
- 5 - FREON COOLING FOR SEMICONDUCTORS
- 6 - BRAKING RHEOSTAT
- 7 - AUXILIARY POWER SUPPLY
- 8 - MAIN COMPRESSOR

- 9 - COMPUTER AND SAFETY EQUIPMENT
- 10 - AUTOMATIC COUPLER
- 11 - IMPACT SHIELD
- 12 - BODYFRAME MADE OF HIGH YIELD POINT STEEL
- 13 - BRAKING CONTROLS
- 14 - TRACK CIRCUIT CODE SENSORS
- 15 - EQUIPMENT HOUSING

- 16 - TYPE Y230 POWER TRUCK
- 17 - TYPE Y237 B TRAILING TRUCK
- 18 - BAGGAGE COMPARTMENT
- 19 - PASSENGER SEATING
- 20 - LIGHT ALLOY ROOF PANELS

Source: SNCF

Figure 3-8. TGV-Atlantique Power Car Arrangement

on the track. Casualties among cab occupants can result from loss of occupant space through gross crushing, or through impacts between cab occupants and cab interior equipment and surfaces resulting from sudden acceleration or deceleration.

Safety requirements developed to protect cab occupants from these dangers in conventional and high speed railroad locomotives and cab-cars include overall vehicle longitudinal strength requirements, and efforts to make the structure surrounding the cab stronger than unoccupied spaces in front of and behind the cab. Cab interior safety is addressed by requirements to avoid sharp corners and hard surfaces as far as possible, for the secure attachment of seats and other interior fittings to the vehicle structure, and for the proper enclosure of potentially hazardous electrical or high temperature equipment.

In both Europe and the U.S., it is customary to design locomotives and unpowered or multiple-unit cab cars to meet the same structural requirements as passenger cars, as described in Section 3.1.1 above. Thus, European vehicles designed using UIC codes have significantly lower longitudinal structural strength than U.S. vehicles which follow FRA and AAR requirements. For high speed train sets and many other train types, it is also customary to use transit-style or tight-lock couplers that provide significant vertical shear strength between vehicles to resist override forces. These customary practices are not all strictly required by applicable codes and regulations.

The U.S. and the U.K. have requirements for an end-plate, pilot, or cow-catcher on locomotives or cab cars to protect against and deflect smaller obstructions on the track.

The UIC code for cab design includes requirements for emergency egress and for designing the locomotives or cab structures so that the crush strength of the space occupied by the train crew is higher than the surrounding structure. These requirements have no equivalents in U.S. regulations, standards, or practices. Also, European practice with existing high speed wheel-on-rail trains focusses on the ergonomic design of the operator's cab, including the layout of controls and instrument displays, temperature control, and ventilation or similar matters.

## **2. U.S. Regulations, Standards, and Practices**

### FRA Regulations

There are no formal FRA structural strength regulations for locomotives or cab cars as distinct from MU cars. However, passenger locomotives and cab cars usually meet the passenger car structural strength requirements given in Section 3.3.1, including the use of tightlock (Type H) couplers to provide coupler vertical strength. Also, there are several other safety-related requirements in CFR Title 49 Part 229 applicable to locomotive cabs.

- Para. 229.119 requires adequate door and seat fastenings, non-slip floors, good general tidiness, and adequate heating and ventilation.
- Para. 299.121 requires that the maximum eight-hour time weighted sound level shall not exceed 90 dBa.

- Para. 229.123 requires that all lead locomotives be equipped with an adequate pilot, end plate, or snowplow.
- Para. 229.127 requires illumination of in-cab instruments and provision of a reading light.

### Other U.S. Standards and Practices

The AAR requires all cab interior fittings and surfaces to be provided with rounded corners and be otherwise designed to minimize the risks of injury should a person be thrown against them. Detailed strength requirements are provided for locomotive engineer seats and the attachment of the seat to the locomotive structure. Otherwise, most AAR locomotive cab standards are formulated for compatibility and interchangeability between components from different manufacturers.

There is growing interest in the "comfort cab" in the U.S. freight railroad industry. This cab design provides an ergonomically designed control console, plus improved temperature control, noise, and vibration insulation. These and other features are intended to provide a much improved working environment for the operator, reducing the risk of operator-error accidents.

An extensive government/industry research program has studied cab crashworthiness. The results of this work are now being implemented in cab design, including the comfort cab, and enhanced strength of cab structures to reduce the risk of gross crushing in a collision or derailment.

### **3. Foreign Standards and Practices**

UIC Code 651 provides detailed requirements for engineer's cabs. The principal provisions are as follows:

- Locomotives and cab cars must meet the standards of UIC Code 560, Load Cases, for overall structural strength as described in Section 3.3.1. A structural design that protects the space occupied by the engineer, with deformations and energy absorption taking place in front of and behind this space, should be used. Although there are no quantitative requirements for energy absorption, it has been considered in high speed train designs, most notably the TGV.
- Sharp edges and hard surfaces must be avoided to minimize injuries should the cab occupants be thrown against cab internal fittings and surfaces.
- All heavy components inside the locomotive body must be secured to the body structure so that they can sustain longitudinal accelerations of 3g.
- Proper protection must be provided against accidental contact with high voltage electrical equipment, hot surfaces, etc.
- An unimpeded passage must be provided to the opposite end of the vehicle for emergency escape.

Console type controls and consideration of human factors in the design of controls and instruments is standard practice, including detailed requirements for forward visibility from the operator's position in the cab.

Other relevant UIC codes are summarized in Table 3-9.

**Table 3-9. Engineer Cab Crashworthiness and Safety**

UIC-566 OR	Coaches - Load cases
UIC-617-4 OR	Position of front and side windows and other windows situated in the driving compartment of electric powered stock
UIC-617-5	Special safety regulations for driver cabs of tractive units
UIC-617-7	Regulations concerning conditions of visibility from driving compartments of electric powered stock
UIC-651	Layout of driver's cab in locomotives, railcars, etc.

Note: Code 651 incorporates and supercedes the provisions in the cited parts of Code 617 for operator's cabs. Code 617 remains in effect for side windows of passenger vehicles and other requirements not applicable to cabs.

### **3.3.3 Vehicle Fittings and Equipment**

#### **1. Introduction and Summary**

This heading includes vehicle features such as external hand rails and steps, doors, and the survivability features of car interior fittings and equipment.

The design of interior fittings and equipment has had a significant impact on the number and severity of casualties in train accidents. Many casualties are caused by secondary impact between car occupants and car interior surfaces and equipment, flying baggage, and detached components, rather than by gross crushing of the car. Lack of adequate arrangements for emergency exits or emergency access for rescue crews also has been a factor in increasing the severity of casualties in an accident. Numerous, but mostly minor injuries have resulted from slipping and falling while moving about the vehicle, or entering or leaving rail vehicles.

The miscellaneous vehicle design requirements discussed in this section serve to reduce the number and severity of casualties in a train accident, and also help prevent casualties from slipping and falling to railroad employees and passengers when moving about or getting on and off vehicles.

The standards and practices followed by different systems are fairly similar, but there are some differences in emphasis and completeness. Detailed requirements are lacking for the avoidance of sharp or hard surfaces in passenger compartments and other ways in which secondary impact injuries can be reduced.

In general, U.S. requirements are less detailed than those in Canada or Europe. However, requirements that do exist are generally similar to their foreign counterparts. Requirements regarding automatic door operation and baggage restraint are lacking in the U.S., although there is little difference in actual practice.

#### **2. U.S. Regulations, Standards, and Practices**

##### FRA Regulations

The only FRA regulations regarding passenger car fittings and equipment are contained in the Railroad Safety Appliance Standards for passenger cars 49 CFR Part 231.14. These require that each car be fitted with a handbrake situated so that it can be operated when the car is in motion, and that the car be provided with specific handholds and steps at car ends and at each door.

##### Other U.S. Standards and Practices

The AAR Manual of Standards and Recommended Practice, Section A Part III, specifies the following:

- Sliding doors only shall be used. However, exterior doors that open outward are acceptable to most operators. Inward-opening doors are definitely not acceptable, because they can prevent escape in an emergency.

- A wrecking tool cabinet must be provided, equipped with an axe and sledgehammer.
- A conductor's brake valve, which can be used to initiate braking in an emergency, should be provided in each car.

Amtrak requires that the attachments of car interior fittings to the structure, including seating, partitions, baggage racks, etc., be designed to withstand accelerations of 6g longitudinally, 3g vertically, and 3g laterally.

### 3. Foreign Standards and Practices

The following UIC codes cover various aspects of the safety of car fittings and equipment:

- Code 566 OR (Load Cases) requires the following:

- Car component attachments to the structure must withstand the following accelerations:

Longitudinal	50 m/sec <sup>2</sup> (5g)
Lateral	10 m/sec <sup>2</sup> (1g)
Vertical	30 m/sec <sup>2</sup> (3g)

A "proof" safety factor (against deformation) of 1.5 should be used in design, increased to 2.0 for components accessible to passengers as a precaution against malicious damage.

Overhead baggage racks must withstand 1000 N per meter (137 lb/ft) plus 850N (191 lb) at any point on the front edge.

- Code 560 OR provides requirements for doors, handrails, and steps as follows:

- Exterior doors must be automatically closed and locked at speeds exceeding 5 km/h (3 mph).

Doors must have a pressure-sensitive edge and be programmed to open for a short period (10 seconds) when obstructed, to prevent accidental entrapment.

- Automatic doors must have an emergency means of being opened manually from both inside and outside the car.
- The entrance must be adaptable to platform heights of between 300 and 900 mm (12 and 36 inches).
- External steps and handrails are required for switching activities (similar to the FRA safety appliance standards).

Other relevant UIC codes are listed in Table 3-10.

**Table 3-10. Vehicle Interior Fittings and Equipment**

UIC-555	Electric lighting in passenger rolling stock
UIC-560 OR	Doors, entrance platforms, windows, handles, handrails, luggage vans
UIC-561	Intercommunication between coaches
UIC-562	Baggage racks and coat hooks
UIC-565-3 OR	Coach layout suitable for conveying disabled passengers in wheelchairs
UIC-566 OR	Car component mountings and overhead baggage racks

Use of automatically operated sliding-plug doors is becoming universal on European rail systems.

#### **4. Specific HSGGT Practices**

##### **Canada**

Draft Canadian passenger railcar regulations require that aircraft-style closed overhead baggage bins be installed, and that heavy baggage be segregated from seating areas and stored in racks provided with longitudinal and lateral restraints meeting the following acceleration requirements:

Longitudinal-5g  
Lateral and vertical-3g

Seat-to-vehicle attachments must be capable of resisting without failure a 5g longitudinal acceleration and 3g lateral and vertical accelerations, with a passenger weighing 83.5 kg (185 lb) in each seat.

Canadian door requirements are similar to those of the UIC. Pictorial emergency instructions for passengers to manually operate automatic doors from the inside and outside of the train must be provided.

##### **Europe**

Apart from following the relevant UIC Codes regarding seat attachment, door features, etc., little information regarding interior accident survivability is found in the published descriptions of the principal European wheel-on-rail HSGGT systems. In particular, descriptions of methods used to minimize the severity of injuries due to secondary impacts between people and interior vehicle surfaces and objects are lacking.

#### **3.3.4 Car and Locomotive Glazing Standards**

##### **1. Introduction and Summary**

The forward-facing windows of the operator's cab are very vulnerable to being hit by flying objects, as in collision scenarios 2.8 and 2.9 in Table 2-2. These include objects dropped from overbridges, objects thrown or becoming detached from trains traveling on an adjacent track, and in the U.S., small arms gunfire. Side-facing windows are subject to the same hazards, but impacts tend to be less severe than with forward-facing windows. To protect vehicle occupants against the adverse consequences of these hazards, guided transport systems have developed glazing impact strength requirements.

##### **2. U.S. Regulations, Standards, and Practices**

###### FRA Regulations

FRA Regulation CFR Title 49, Part 223.9 requires that locomotives and cars be fitted with certified glazing, to the following standards:



Type I: Forward-facing locations (e.g., driving cabs). Sustain impacts from 11 kg (24 lb) object with dimensions 0.2 x 0.2 x 0.4m (8" x 8" x 16") at 13.4m/sec (44 ft/sec) and a 0.22 caliber rifle bullet at 293m/sec (960 ft/sec) without penetration. Part 229.119 also requires that the windows provide an undistorted view of the right-of-way from the normal driving position, but does not impose quantitative requirements.

Type II: Side-facing windows. Sustain impacts from an 11 kg (24 lb) object with dimensions 0.2 x 0.2 x 0.4m (8" x 8" x 16") at 3.7m/sec (12 ft/sec) and a 0.22 caliber rifle bullet at 293m/sec (960 ft/sec).

Each passenger car must be fitted with at least four emergency opening windows.

The present FRA safety glazing requirements were developed for conventional speed operations, up to 175 km/h (110 mph).

#### Other U.S. Standards and Practices

The AAR passenger car standards requires that the four emergency exit windows should be of minimum size, 0.45 x 0.6m (18" x 24").

Amtrak requires that the normal maximum window size is 0.71m<sup>2</sup> (1100 sq.in.), to minimize the risk of passengers being ejected from a passenger car in an accident, particularly after overturning.

### **3. Foreign Standards and Practices**

Glazing requirements are provided in the UIC codes summarized in Table 3-11.

- Requirements for forward-facing windows of operator's cabs in a cab car:
  - Code 651, paragraph 1.7.4, recommends that these shall be designed to survive impact by a standard 1 kg (2.2 lb) object (Figure 3-9) at a speed of maximum train speed + 160 km/h (100 mph).
  - Code 651 specifies a minimum field of view from forward-facing windows for a person seated in the driving position.
- Requirements for side-facing windows and other glass in locomotives or cab car operator's compartments:
  - Code 651 paragraph 2.7.3 requires that toughened or laminated safety glass be used, i.e., that which if broken will not have sharp edges. Similar standards must be met by any other glass in the cab - internal doors, lockers, gauges, etc. At least one window on each side must be large enough to serve as an emergency escape window. The glass must be breakable to permit emergency escape.

**Table 3-1 1. Window Glazing Standards**

UIC-564-1 OR	Coaches: windows made from safety glass
UIC-560 OR	Doors, windows, handles
UIC-617-4	Forward, side-facing windows requirements
UIC-617-7	Minimum field of view
UIC-651 OR	Layout of driver cabs in locomotives, rail cars, multiple units, and driving trailers

Note: UIC-651 incorporates and supercedes the provisions of parts of Code 617. Code 617 remains in force for vehicles built before the adoption of Code 651.

- There are no specific impact strength requirements for side windows.
- Passenger car side windows.
  - Code 564-1 requires that all windows shall be of toughened or laminated safety glass (including both panes of double glazing). This code also requires that at least two windows per car (one on each side) shall be emergency escape windows. This can be achieved by having the window removable from its frame, or providing an emergency hammer for breaking the glass. The hammer approach is customarily followed in European passenger cars. There are no specific impact strength requirements.

Individual railways may fulfill glazing performance requirements that exceed the UIC requirements for selected vehicle types.

(Source: UIC Code 651)

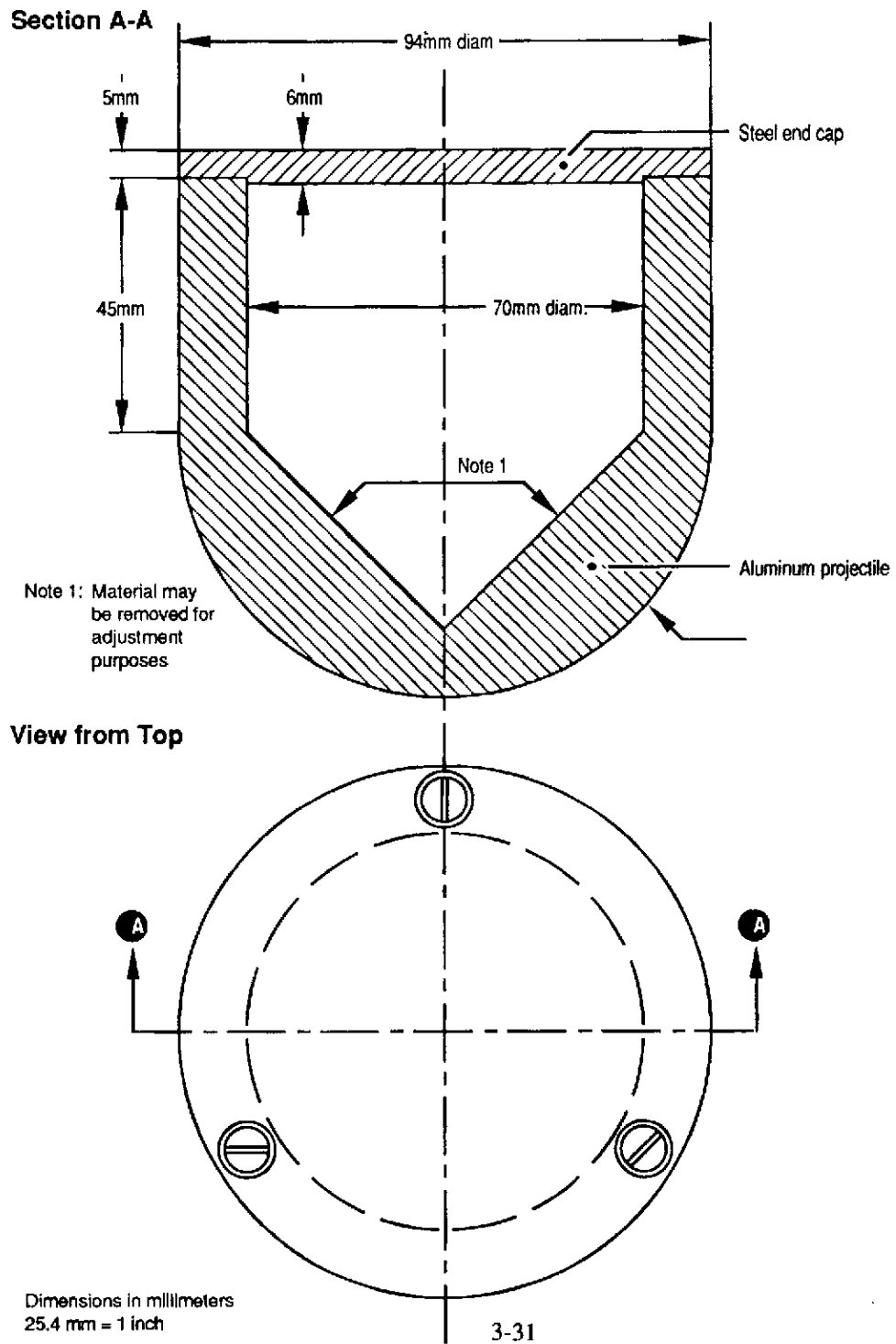

**Figure 3-9. UIC Standard Projectile for Testing Forward-Facing Cab Windows**

## **4. RECOMMENDED GUIDELINES FOR COLLISION AVOIDANCE AND ACCIDENT SURVIVABILITY**

### **4.1 INTRODUCTION**

This chapter develops recommended guidelines for collision avoidance and accident survivability of HSGGT systems, based on the preceding chapters of this volume that discuss collision and accident threats and how these threats are addressed in other guided transportation systems, and on the information from Volumes 2 and 3 on collision avoidance and accident survivability techniques. The guidelines are complementary to the specifications developed in Volume 4, which provide formal definitions of the safety performance requirements for HSGGT systems, together with tests and analyses to be used to demonstrate compliance with the specifications.

There are two parts to this chapter, their purpose is to help an HSGGT system designer or developer meet required safety performance goals. The first part, Section 4.2, discusses in detail the development of numerical HSGGT system safety performance goals that correspond to the FRA's overall requirement that HSGGT systems shall exhibit "equivalent safety" when compared with other intercity public transportation systems. These safety performance goals are also incorporated into the formal safety specifications provided in Volume 4 of this report. The second part, Section 4.3, provides guidance on how to meet these system safety performance goals. Guidance is provided on HSGGT system design choices with respect to the collision and accident scenarios described in Chapter 2, and which appear to be cost-effective ways of meeting the performance goals developed in Section 4.2. This guidance is based on the reviews of foreign HSGGT technology in Chapter 3 of this volume, and the state-of-the-art reviews of collision avoidance and accident survivability in Volumes 2 and 3.

### **4.2 DEFINITION OF EQUIVALENT SAFETY**

The goal of the Federal Railroad Administration's efforts on HSGGT safety is to ensure that the safety level achieved by any HSGGT system operating in the United States is equivalent to or better than that achieved in existing intercity railroad operations. The purpose of this discussion is to define and quantify 'equivalent safety,' and to put this in context by comparing it with safety levels achieved by passenger rail systems in other countries and by commercial air carriers.

The question of what is acceptable risk in common-carrier public transportation operations, and how to quantify acceptable safety must be considered from several different points of view. These points of view are those of society at large, the individual traveler using the system, system employees, and other persons who are at risk of being directly affected by an accident. There are three categories of "other person" at risk as a result of HSGGT operations. The first is the bystander who is not on the HSGGT system property, but is near enough to be affected by a collision or other type of undesired event on the HSGGT system. The second is a highway user at a grade crossing used by wheel-on-rail HSGGT vehicles or trains. The third is a trespasser on an HSGGT guideway who is at risk of being struck by a moving vehicle.

The following paragraphs discuss how to quantify "acceptable risk" in HSGGT operations from the perspectives of society at large and of each category of person who might be adversely affected by these operations.

This discussion is confined to risks arising out of vehicle movements. Other accident and casualty risks that may exist on an HSGGT system, for example, from events in a terminal or maintenance facility, are not addressed in this study.

### Societal Acceptability of Accident Risks

Societal risk is best quantified by a risk profile. A risk profile quantifies risk on a frequency versus severity plot, usually showing the annual frequency of events at or above each severity level. In the case of transportation accidents and other accidents to man-made systems, the usual measure of severity is the number of fatalities. Injuries are rarely used, primarily because of missing data or inconsistent definitions of an injury among different data sources, rather than any judgment that injuries are not important. Figure 4-1 presents a risk profile for several types of accidents to man-made systems. It has been found that this is a good way of illustrating the public perception and acceptance of risk. Public perception of risk tends to be based on the number of severe accidents, and also tends to reflect the incidence of these accidents in a calendar period, independent of the level of activity which leads to the accidents. For example, flying in an airplane operated by a major scheduled airline is perceived as dangerous by some as a result of the occasional severe accident, although flying is very safe when measured by objective criteria.

Public response to an accident is a direct function of severity. There is usually little public concern about non-fatal accidents, except locally and among professionals concerned with the system in question. Accidents that cause fewer than ten fatalities excite some concern and will be subject to a formal investigation, leading to detail changes in operating or engineering practices. An accident that causes more than ten fatalities is likely to lead to major public concern, a thorough investigation by responsible authorities, and significant changes in safety regulations and practices. It should also be borne in mind that although public perception of risk in transportation and elsewhere may be inconsistent from risk analyst's point of view, the perceptions exist, cannot be changed in the short term and must be taken into account in safety requirements specifications. It is not wise to conclude that public perception of risk in a particular situation is not logical, and therefore need not be considered. Overall, severe accidents can be very damaging both to the HSGGT system operator and to all private and government organizations involved with a particular industry and activity. It is highly desirable that the severe accident frequency for an HSGGT system be below that of other equivalent modes.

The response to the two most severe railroad accidents in the last 20 years support these generalizations. The electric multiple-unit commuter train collision on the Illinois Central in 1974 led to new requirements for structural crashworthiness of passenger railcars and extensive research into the subject of crashworthiness. The Chase, Maryland, high speed collision in 1987 between an Amtrak train and Conrail locomotives led to new regulations regarding engineer training and certification, drug testing, and train control systems on the North East corridor.

Although societal perception of transportation risk is only weakly influenced by the level of activity in a particular transportation mode, a risk profile relative to activity (traffic levels) for HSGGT system safety analysis must be defined for safety specification purposes. Use of an activity-related risk profile provides a goal that does not depend on the performance of other transportation systems. However, the risk profile must be specified so that at the forecast traffic

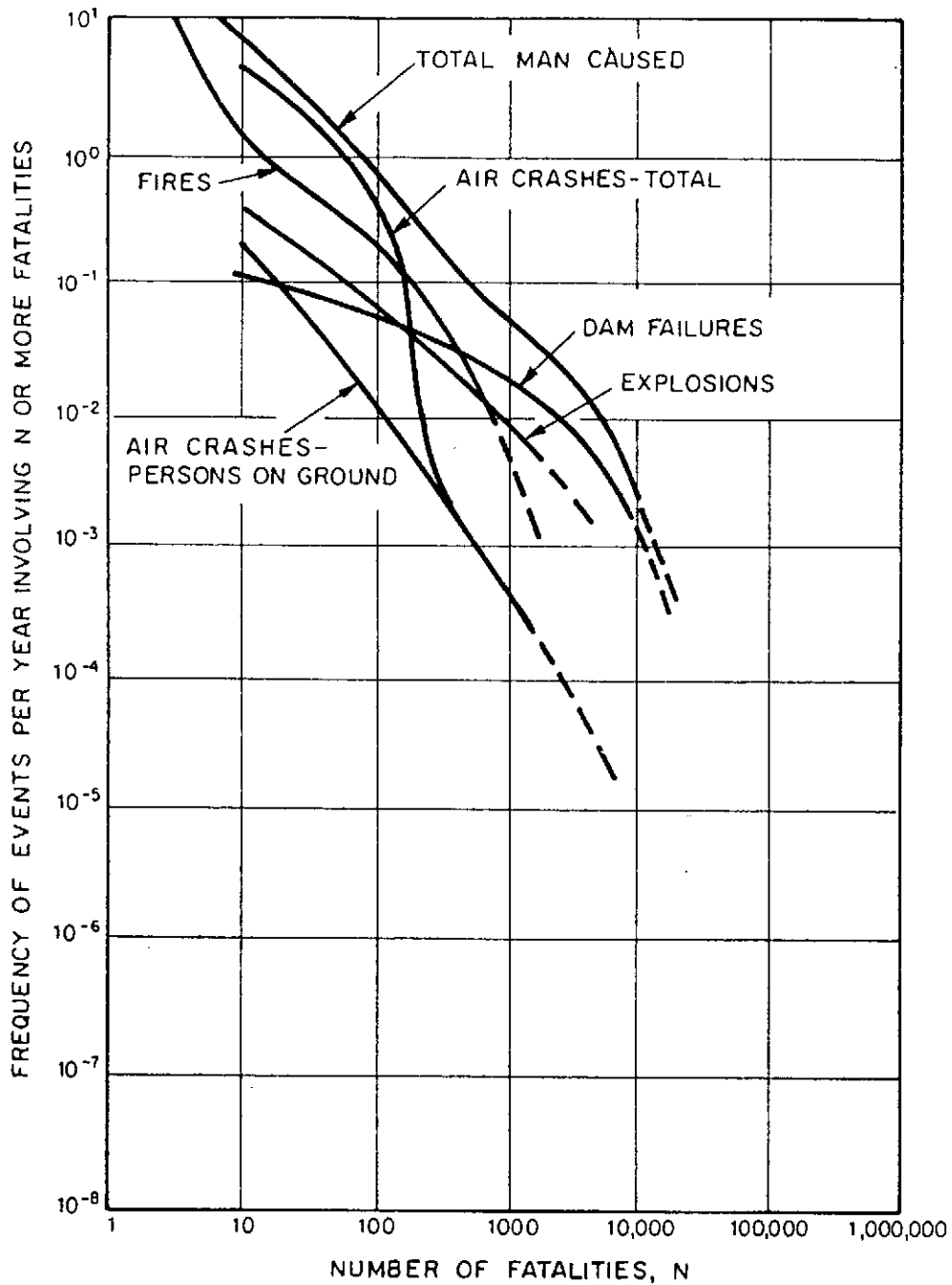

(Source: "Reactor Safety Study", US Nuclear Regulatory Comm., 1975)

**Figure 4-1. Risk Profiles for Accidents to Man-Made Systems**

level, the HSGGT system does not significantly increase the frequency of occurrence of severe transportation accidents in the U.S.

To provide a baseline for an HSGGT target risk profile, approximate risk profiles for U.S. passenger railroads and for major domestic airlines are presented in Figure 4-2. The railroad risk profile is estimated from a combination of 20 years of NTSB severe accident reports as summarized in the Appendix, and the data on all reportable railroad accidents as contained in the FRA railroad accident database and the annual FRA Railroad Accident/Incident Bulletins (References S1 and S2). Data on total passenger-km were obtained from the ENO foundation transportation statistics, Reference S5. The aviation risk profile is for the U.S. domestic flights of U.S. major domestic airlines only, derived from 10 years of aviation accidents as listed in Table 4-1. Commuter airline accidents and accidents on international flights of domestic airlines are not included. The data sources both for accidents and passenger-km were the FAA statistics, Reference S4.

The risk profiles shown in Figure 4-2 illustrate the significant differences in the frequency and severity of commercial aviation accidents relative to intercity railroad accidents. At severity levels below ten fatalities per accident, there are substantially fewer aviation accidents than railroad accidents per billion passenger-km. The difference is less marked at severity levels between 10 and 100 fatalities per accident, and only aviation accidents result in severity levels exceeding 100 fatalities per accident. The flatter slope of the aviation profile reflects the all-or-nothing nature of aviation accidents. Overall, the aviation accident rate is substantially lower than the railroad accident rate. However, this appears to be inconsistent with the public perception of the safety of the two modes, illustrating how perception is influenced strongly by accident severity, but only weakly by the fact that the amount of air travel is much greater than rail travel in the U.S. Accidents that result in personal injury but no reportable damage to the train or airplane have been excluded from the data for both modes. The data from which the profiles were obtained is given in Table 4-2A.

An alternative way of presenting the risk profile is to use a "per passenger trip" denominator, rather than "per passenger-km." The average length of intercity rail trips in the U.S. is about 30% of that of air trips, leading to the per-trip risk profile data provided in Table 4-2B. On a per-trip basis, the frequencies of serious railroad and airline accidents with more than 10 fatalities are very similar. The overall conclusion is that on either a per-trip or per-passenger-km basis, trains suffer many more minor accidents than commercial aircraft, but the incidence of severe accidents is quite similar in both modes. It should be noted that foreign HSGGT systems, most notably the Japanese high speed (Shinkansen) railways, have a very good safety record. The Japanese Shinkansen high speed rail systems have carried a total of almost  $1000 \times 10^9$  passenger-km without a passenger fatality since the initiation of service between Tokyo and Osaka in 1964. Impressive as this seems, however, this total traffic is only about 2.3 times that of U.S. annual domestic air traffic. The occurrence of two accidents involving 10 or more fatalities would give the Shinkansen an equivalent safety record to U.S. airlines with respect to serious accidents. Conversely, there have been periods of nearly two years between serious aviation accidents in the U.S., for example between 9/6/85 and 8/16/87, as shown on Table 4-1. The total passenger traffic over this period would be on the order of 800 billion passenger-km, which approaches the aggregate Shinkansen traffic.

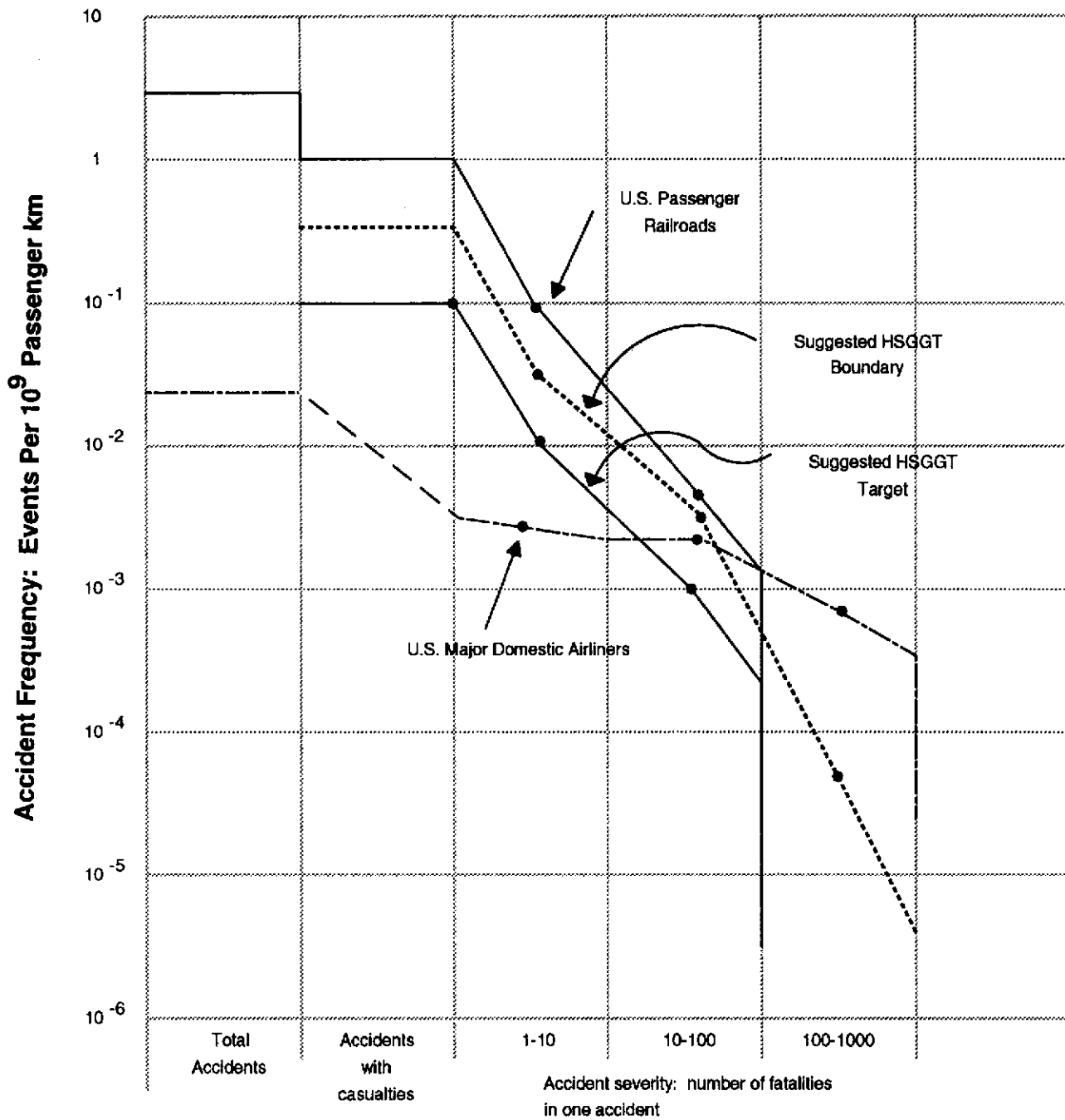

Sources: Refs S1, S2, S3, S4 and S5

**Figure 4-2. Risk Profiles for Passenger Railroad and Airline Operations in the United States**



**Table 4-1. Fatal Accidents U.S. Domestic Passenger Air Service - 1978-1989**

Location	Operator	Date	Aircraft		Fatalities			Aboard	Total Reported Type of Accident
			Total	Passenger	Crew	Others			
Los Angeles, CA	Continental Airlines	3/1/78	DC-10	2	2	0	-	197	Crashed during rejected takeoff
Pensacola, FL	National Airlines	5/8/78	B-727	3	3	0	-	58	Crashed during final approach
Portland, OR	United Airlines	12/28/78	DC-8	10	8	2	-	189	Crashed during landing
San Diego, CA	Pacific Southwest Airlines	9/25/78	B-727 C-172	142 2	128 -	7 -	7 2	135 2	Midair collision
Clarksburg, WV	Allegheny Airlines	2/12/79	N-262	2	1	1	-	25	Crashed during takeoff
Newark, NJ	New York Airlines	4/18/79	S-61	3	3	-	-	18	Crashed after takeoff
Chicago, IL	American Airlines	5/25/79	DC-10	273	258	13	2	271	Crashed shortly after Takeoff
Hyannis, MA	Air New England	6/17/79	DHC-6	1	-	1	-	10	Crashed during approach landing
Washington, DC	Air Florida	1/13/82	B-737	78	70	4	4	79	Aircraft crashed into river after striking highway bridge shortly after takeoff during snowstorm.
Boston, MA	World	1/23/82	DC-10	2	2	0	0	212	Aircraft slid off the end of the icy runway after landing.
Kenner, LA	an American World	7/9/82	B-727	153	137	8	8	145	Aircraft crashed into residential area after takeoff.

**Table 4-1. Fatal Accidents U.S. Domestic Passenger Air Service - 1978-1989 (continued)**

Location	Operator	Date	Aircraft	Fatalities				Total Aboard	Reported Type of Accident
				Total	Passenger	Crew	Others		
Honolulu, HI	Pan American World	8/11/82	B-747	1	1	0	0	288	Device exploded beneath passenger seat.
Brainerd, MN	Republic Airlines	1/9/83	CV-640	1	1	0	0	36	Struck snowbank during landing. Propeller separated from engine and penetrated cabin, fatally injuring passenger.
Pinckneyville, IL	Air Illinois	10/11/83	HS-748	10	7	3	0	10	Collided with terrain following electrical failure.
Sioux Falls, SD	Ozark Airlines	12/20/83	DC-9	1	0	0	1	86	Wing struck snow sweeper during rollout. The sweeper operator was killed.
Dallas, TX	Delta	8/2/85	L-1011	135	126	8	1	163	Crashed on airport during final approach through wind shear.
Milwaukee, WI	Midwest Express	9/6/85	DC-9	31	27	4	0	31	Crashed shortly after takeoff when one engine failed and the second lost power.
Romulus, MI (Detroit)	Northwest	8/16/87	DC-9	156	148	6	2	155	Crashed onto freeway shortly after takeoff.
Denver, CO	Continental	11/15/87	DC-9	28	25	3	0	82	Crashed while taking off during snow storm.

**Table 4-1. Fatal Accidents U.S. Domestic Passenger Air Service - 1978-1989 (continued)**

Location	Operator	Date	Aircraft	Fatalities				Total Aboard	Reported Type of Accident
				Total	Passenger	Crew	Others		
San Luis Obispo, CA	PSA	12/7/87	BA-146	43	38	5	0	43	Suspected suicide/sabotage
Maui, HI	Aloha Airlines	4/28/88	B-737	1	0	1	0	95	Portion of top of fuselage tore away in flight
Dallas, TX	Delta Airlines	8/31/88	B-727	14	12	2	0	108	Crashed shortly after take-off.
Honolulu, HI	United Airlines	2/24/89	B-747	9	9	0	0	355	10 by 40 foot section of fuselage tore away in flight.
Sioux City, IA	United Airlines	7/19/89	DC-10	111	110	1	0	296	Crashed during emergency landing after loss of engine and hydraulic system.
Flushing, NY	US Air	9/20/89	B-737	2	2	0	0	63	Aircraft departed the end of the runway following an aborted takeoff.

Note: Accidents causing employee fatalities but no aircraft damage have been excluded.

Source: Reference S4



What does this mean for societal safety requirements for HSGGT systems? An HSGGT system will potentially substitute for both domestic air and intercity rail travel. It may also increase the total level of travel by public transportation. The total traffic carried by HSGGT systems in the U.S. could approach  $20 \times 10^9$  pass-km annually, if all current proposals come to fruition. This is the same order of magnitude as current traffic on intercity and commuter rail systems. If the overall risk profile of intercity public transportation systems in the U.S. is to remain approximately unchanged, a safety performance between that of existing rail systems and major commercial air carriers is needed for HSGGT systems. In addition, a demanding target for the most severe accidents (over 10 fatalities) is highly desirable because of the adverse effect of any such event on a growing HSGGT industry. Finally, accidents that cause more than 100 casualties should be an order of magnitude less likely than with commercial air carriers. The public expectation is that ground transportation systems simply do not have such severe accidents, although the public accepts that they can occur in aircraft operations.

A risk profile that results from application of these considerations is shown as the suggested HSGGT boundary (broken line) on Figure 4-2.

A more demanding safety goal is shown as the "suggested HSGGT safety target" on Figure 4-2. Experience with HSGGT systems that are fully segregated from other forms of transportation, such as the Japanese Shinkansen, have both created an expectation of fatality-free operation, and demonstrated that a fatality-free record can be maintained for many years. This suggests that HSGGT systems that are fully or mostly segregated could achieve the more demanding target, and that this performance may be expected of such a system.

The actual figures corresponding to the two risk profile limits for future HSGGT operations in the U.S. are as given in Table 4-3 below.

**Table 4-3. HSGGT Societal Risk Performance Criteria**

	Accidents per 109 Passenger-km	
	Boundary of Acceptability	Target Performance
Accidents causing casualties	$>0.5$	0.1
Accidents causing fatalities	$> 0.05$	0.01
Accidents causing over 10 fatalities	$>0.005$	0.001
Accidents causing over 100 fatalities	$>0.00005$	Zero

### Individual Traveler Risk

The individual traveler is concerned with the personal risk of becoming a casualty in an accident. The traveler, unlike society at large, is not concerned with the severity of the accident, only with the probability of suffering death or injury as an individual while undertaking a particular journey. Thus, the appropriate measures of risk for individual travelers are casualties per trip or per unit of distance travelled. Since casualties are rare events, a measure of fatalities per billion

passenger-kilometers is used for the aggregate distance travelled risk measure, and fatalities per million passenger trips for the "per trip" risk measure. The choice between using trips or aggregate distance travelled is a matter of judgment. Aggregate distance is more commonly used, but both appear to be equally suitable, and there is little in what is known about public attitudes to risk to suggest that one or the other is more appropriate.

Table 4-4 presents individual casualty rates for U.S. railroads, U.S. airlines, and European railroads taken from the Railway Gazette article by Hope (Reference 11). Risk data is given on both aggregate distance travelled and per-trip bases. The per-trip fatality rates for complete passenger rail systems are much lower than for intercity rail alone because large numbers of short commuter trips are included in system totals. Given the sensitivity of casualty rates to a few bad accidents, U.S. railroads, U.S. airlines, and the Swedish and Netherlands railways in Europe can be regarded as having a similar safety performance as measured by fatalities per billion passenger-km. Because trip length on an airline is greater than an intercity trip on U.S. railroads (airline at 1273 km versus train at 385 km), the railroad looks better on a per-trip basis and worse on a per passenger-km basis. French and British railways have a significantly worse record than Sweden and the Netherlands. Part of the difference is believed to be due to the fact that extensive ATP installations were operational in Sweden and the Netherlands during this period, but were lacking in France and Britain. The figures for Britain also include a large number of falls from trains with outwardly opening manually operated swing doors, which are not used on other systems. French railways suffered an unusual number of very serious accidents over the period reviewed, which may not be typical of long-run performance. Note that all of these severe accidents occurred to conventional trains, not in high speed operations on dedicated high speed lines.

Based on the figures in Table 4-4, it is suggested that HSGGT individual traveler safety performance should be equal to or better than 0.2 fatalities per  $10^9$  passenger-km. This performance is achieved by the European railway with the best safety record, and is representative of current U.S. domestic airline and intercity railroad performance.

### **Employee Risk**

Employees of an HSGGT system should not be subject to an unacceptable risk of being killed or injured while at work. A reasonable definition of unacceptable risk is that which exceeds the occupational risks for employees in comparable jobs, or among the employed population of the United States as a whole.

The occupational risk for U.S. railroad workers can be calculated from Tables 1 and 9 of Reference S1 for 1991. Assuming the average full-time railroad employee works 1900 hours in a year, the fatality rate over the five years 1987-1991 inclusive is shown in Table 4-5.

In contrast to bystanders, the risk of fatalities involving trespassers or highway users at a rail-highway grade crossing is very high on a conventional railroad. There are about 100 fatalities annually in these two categories of that can be attributed to conventional U.S. intercity rail (Amtrak) operations, as shown in the Table 4-6 for the last five years. (Reference S1)

**Table 4-4. Individual Passenger Transportation Risk**

	<b>Fatalities per 10<sup>9</sup> pass-km</b>	<b>Fatalities per 10<sup>9</sup> trips</b>
Train Accidents U.S. Intercity Railroads (Amtrak)	0.35	0.133
All U.S. Railroads, (IC and commuter), All Passenger Fatalities on Trains	0.39	0.021
European Railways (all passenger fatalities)		
Great Britain	1.26	0.061
France	0.92	0.072
Netherlands	0.20	0.0084
Sweden	0.29	0.024
U.S. Domestic Airlines	0.14	0.22

Average Trip Lengths: (km)

U.S. Intercity Railroad	385
U.S. Passenger Railroad (IC and commuter)	54
Great Britain	48
France	78
Netherlands	42
Sweden	84
U.S. Domestic Airlines	1273

Notes: All information is for 1980-1989, or 1981-1990  
Metric equivalent 1 km = 0.62 mile

Sources: References 11, S1 through S5, Chapter 2 and Appendix A

**Table 4-5. Railroad Employee Fatality Risk**

Year	Number of Fatalities	Number of Workers (1000's)	Annual Fatality Rate per 100,000
1987	55	326	16.9
1988	43	320	13.4
1989	49	304	16.1
1990	40	292	13.7
1991	39	278	14.0
		Five-Year Average	14.8

For comparison, the annual fatality rate among workers in the U.S. as a whole ranges from over 40 per 100,000 in high-risk occupations such as agriculture and mining, to 6 per 100,000 in manufacturing, and 4 per 100,000 in most service industries. The national average is 9 per 100,000. (Reference 12)

An HSGGT system ought to be able to improve upon the employee safety record of the conventional railroad industry, which is largely concerned with freight operations. The HSGGT system will lack most of the hazardous switching and classification yard activities characteristic of a freight railroad, and should have a significantly lower incidence of train or vehicle accidents such that it can meet passenger safety goals in high speed operation. At a minimum, it is suggested that the annual worker fatality rate should not exceed the national average of 9 per 100,000 employees, and matching the service industry performance of 4 per 100,000 should be a goal. The people covered by this goal should include HSGGT system employees, employees of contractors to the HSGGT system working on HSGGT property, and business visitors on HSGGT property.

### **Risks to Other Persons**

As indicated above, there are three categories of "other person" who may be at risk of becoming a casualty as a result of HSGGT operations. These are: (1) bystanders not on HSGGT property who may be affected by an accident on HSGGT property, (2) trespassers on HSGGT property, and (3) highway users at at-grade rail-highway crossings. The last category only applies to wheel-on-rail HSGGT systems that operate over grade crossings for a portion of the journey.

Risks to bystanders from railroad or aviation accidents are very low in the United States. A review of the last four years of FRA railroad accident statistics (Reference S1, 1988-91 inclusive) reveals a total of only four fatalities to "nontrespassers" due to train accidents that were not at-grade rail-highway crossing collisions. The nontrespasser category includes employees of contractors to the railroad and others having a legitimate reason to be on railroad property. Thus, the four fatalities are a maximum and actual bystander fatalities are likely to be fewer, perhaps even zero. The commercial air carrier accidents listed in Table 4-1 resulted in 26 fatalities to people on the ground, an average of about two per year.

This analysis, therefore, indicates that the target for bystander fatalities should be very low, or of the order of 1 bystander fatality per 200 billion passenger-km, a ratio derived from experience of fatalities to people on the ground due to major carrier commercial aircraft accidents.



**Table 4-6. Trespasser and Grade Crossing Fatalities in U.S. Intercity Rail Operations**

Year	Fatalities		Total
	Nontrespasser*	Trespasser	
1987	15	67	92
1988	4	76	80
1989	13	97	110
1990	24	80	104
1991	20	75	95

\*Almost all nontrespasser fatalities are highway users at a rail-highway grade crossing.

Source: [S1]

These fatality numbers are much higher than those of employees, passengers, and bystanders combined. Reducing the incidence of these fatalities by efforts to change the behavior of the public is at best a slow process, and it is not economically feasible to eliminate the risks. Thus, it is difficult to develop meaningful safety targets for HSGGT systems with respect to risks to trespassers and at-grade crossings. A wheel-on-rail HSGGT system operating over existing tracks will be exposed to the same risks as conventional railroad operations and will have the same options for reducing the incidence of grade crossing accidents and fatalities. In the short term, only full grade separation or elimination of crossings will prevent grade crossing accidents. Systems that warn of an obstructed crossing or malfunction in the crossing equipment, allowing high speed trains to be stopped before reaching the crossing, may contribute to grade crossing accident reduction, but have yet to be tested in the U.S.

Use of an elevated guideway and high-security fencing will reduce but not eliminate trespassing onto the guideway. A determined trespasser will always be able to overcome barriers in order to trespass. However, a substantial improvement on present conventional railroad performance should be possible. The Federal Transit Administration "Section 15" reports on transit operations [S6] indicate that the number of non-train-accident fatalities per train-mile for segregated rail mass transit systems is approximately 15 times lower than for commuter rail services operated over conventional railroad lines. The actual figures for 1989 are 0.048 fatalities per million train-miles for rail rapid transit versus 0.737 fatalities per passenger-mile for commuter rail. These fatalities include both trespassers and employees or contract personnel having a legitimate reason to be on the property.

### Summary

The key conclusions of this section on HSGGT safety performance targets are as follows:

- **Societal Risk:** A risk profile that is equal to or better than the suggested HSGGT boundary on Figure 4-2, preferably conforming to the suggested HSGGT target on Figure 4-2.

- Individual Traveller Risk: Fatality rate below 0.2 per  $10^9$  passenger-km.
- Employee Risk: Fatality rate fewer than 10 per 100,000 employee-year, and preferably at 4 per 100,000 employee-year.
- Bystander Risk: Not more than one fatality per  $100 \times 10^9$  passenger-km. This is equivalent to the present fatality rate for people on the ground from commercial aircraft accidents.
- Risks to highway users in rail-highway grade crossings. Their risks should be assessed on a location-specific basis and all economically feasible mitigation measures adopted.
- Trespasser Risk: Substantial improvement on present intercity passenger railroad experience, of about 9 fatalities per billion passenger-km.

### **4.3 GUIDELINES FOR COLLISION AVOIDANCE AND ACCIDENT SURVIVABILITY**

#### **Introduction**

The task of the HSGGT system designer is to design a system with a combination of collision avoidance and accident survivability features that meets the safety goals developed in Section 4.2, as well as other system performance and cost goals.

The purpose of this section is to offer some guidelines regarding effective approaches to achieving the required safety goals with respect to the different collision and accident scenarios. For example, it is virtually impossible to prevent a bird flying in front of an HSGGT vehicle. Therefore, the vehicle must be designed to survive an impact with a bird. On the other hand, it is virtually impossible to ensure the survival of all occupants in a maximum speed collision between HSGGT vehicles or trains. The only logical approach is to ensure that the risk of such a collision occurring is extremely low.

Each of the HSGGT collision scenarios developed in Chapter 2 of this report is discussed. Approaches to both avoiding the occurrence of a collision and surviving the consequences are identified and discussed, and finally guidance is furnished regarding the most appropriate strategy or strategies to be followed by different types of HSGGT systems and in different operating environments.

#### **Scenario Group 1: Collision Between Similar Vehicles or Trains on the Same Guideway**

Collisions between similar vehicles and trains on the same guideway can occur in principle anywhere on an HSGGT system as a result of human error, a failure in signalling or vehicle control systems, or a failure of a braking system. Human error has been the predominant cause of collisions of this type in conventional rail operations systems.

Collisions between similar vehicles are categorized by the speed of the colliding vehicles or trains, and the kinds of vehicles colliding. Collisions may occur between two power vehicles, between a power vehicle and a passenger vehicle, or between two passenger vehicles, depending on the vehicle and train configurations operated.

The analysis of past railroad accidents in Chapter 2 indicates that any high speed collision between HSGGT vehicles or trains (i.e., at speeds exceeding about 200 km/h (125 mph)) will inevitably be very destructive and there is no practical way to avoid a large number of fatalities and serious injuries in such an event. Therefore, emphasis must be on collision avoidance, through the use of highly reliable Automatic Train Protection (ATP) systems, whether the vehicles are manually or automatically operated. The ATP systems in use today, which are based on conventional railroad signalling technology (track circuits, relay logic, etc.), have been very successful in preventing collisions on the Japanese Shinkansen and French TGV lines, and on advanced rail mass transit systems, such as the Washington and Atlanta Metros, and BART in San Francisco. Provided that care is taken in introducing new technology into ATP and train control functions (microprocessors, digital data communications, etc.) to ensure that there is no reduction in safety performance, ATP should meet the primary requirements of high speed collision avoidance.

A second requirement for high speed collision avoidance is to ensure the integrity of braking systems. The conventional railroad air brake has sufficient reliability to meet this requirement, provided that pre-departure operating tests are faithfully carried out. Alternative types of brake control and actuation must demonstrate performance comparable to that of the railroad air brake.

The choice between using the collision avoidance or accident survivability approaches to safety is less clear-cut at low and moderate speeds. Experience of existing railroad vehicles in moderate collisions (say at speeds up to 50 km/h (30 mph)) suggests that it is technically possible to design vehicles such that fatalities or serious injuries are avoided in most accidents of this type. Some HSGGT systems that rely on ATP for high speed operations may plan to operate without ATP at limited speed in the event of a control system failure. A wheel-on-rail system may operate over existing rail lines that lack ATP for a portion of the journey. In either case, provision of adequate survivability performance in an HSGGT vehicle is required. The required survivability performance must include protection against gross crushing of occupied areas in the vehicle, and measures to mitigate the severity of impacts between occupants and interior surfaces and fittings. Finally, even with very comprehensive collision avoidance systems and procedures, the possibility of a collision cannot be completely eliminated. Provision of basic accident survivability features in any HSGGT vehicle must be the prudent course of action.

End vehicles are most vulnerable to gross structural damage in low and intermediate speed collisions. Arranging a train or vehicle so that the end vehicles or the outer portion of the end vehicles or vehicle sections are unoccupied reduces casualty risk significantly, and is a valuable survivability feature. Trains that consist of several passenger vehicles or vehicle sections situated between power vehicles (such as the TGV) have this feature. Multiple Unit (MU) vehicles and trains that feature passenger accommodations in end vehicles may be more vulnerable to casualties in a low and intermediate speed collision, and manual operations may have to be restricted in some way (e.g., lower speeds) to meet overall safety performance requirements.

Vehicle operators are almost invariably in the head end vehicle and are especially vulnerable in a collision. Operators' cabs should be well equipped with structural and survivability features such as high-strength structure around the operators' compartment, and impact-friendly interior design.

A final point about end vehicles is that they should be designed with some means of minimizing the risk of override when colliding with an end vehicle of a similar train. A transit-style

anticlimber would meet this requirement, but would have to be situated behind a lightweight housing to maintain the necessary smooth aerodynamic shape of the exterior. The housing could be designed to break away in an impact.

Connections between vehicles and vehicle sections should be designed to resist override and buckling, to ensure that there is no gross structural damage to intermediate vehicles or vehicle sections in a minor or moderate collision. However, intermediate vehicles can suffer sharp acceleration pulses in even quite minor collisions. This means that vehicle interior surfaces and fittings must be designed to reduce the risk of breaking away or causing injury in such events.

## **Scenario Group 2: Collisions with Obstructions on the Guideway**

The strategies for dealing with collisions with obstructions on the guideway vary considerably with the size, weight, and nature of the obstruction; how the obstruction got onto the guideway; and available means for detecting the presence of obstructions.

Collisions on at-grade rail-highway crossings are a concern when wheel-on-rail HSGGT trains operate over existing railroad tracks. Such collisions are frequent on existing rail lines. Actions to avoid grade crossing collisions include elimination of crossings and various approaches to reducing the incidence of collisions. Grade crossings can be eliminated by grade separation, which is costly and normally only justifiable at busy crossings, or simply closing the highway, which is contingent on governmental approvals and community acceptance. Efforts can be made to reduce the incidence of grade crossing collisions by programs to educate highway users regarding crossing safety, and the installation of improved devices to warn highway users of the approach of a train. An alternative approach, used in Sweden, is to install devices to detect a stalled highway vehicle on the crossing, or a malfunction of grade crossing warning systems, and link the devices to the train control system so that a train approaching an obstructed crossing can be stopped. However, experience has shown that efforts to reduce the frequency of collisions between trains and highway users on at-grade rail-highway crossings yield modest results. Therefore, collisions must be expected where an HSGGT train operates over at-grade rail-highway crossings that cannot be grade-separated or eliminated. Accident survivability features of a train operated over at-grade rail-highway crossings should be such that a collision with a maximum-weight highway vehicle does not result in a serious injury to train occupants. Collisions with exceptionally heavy vehicles on a grade crossing have the potential for more serious consequences, as at Hixon in the UK and Voiron in France.

The risk of collision with a large animal on the guideway (Scenario 2.2) can be minimized by using an elevated guideway and providing secure fencing. However, it is probable that no precaution can be 100% effective over time, particularly where agile animals such as deer or bears are involved. Therefore, it will be prudent to design the leading end of an HSGGT vehicle so that it can survive a collision with a large animal without sustaining damage that would prevent the vehicle from being brought safely to a stop, and without injuries to occupants.

A collision with a person on the guideway (Scenario 2.3) can occur when a trespasser gains access to the guideway, or when there has been a breakdown in procedures for permitting work on the guideway by an employee. The incidence of trespass can be reduced but not entirely eliminated by use of an elevated guideway, fencing, and public education programs. The incidence of collisions between vehicles and employees on the guideway can be reduced but not

entirely eliminated by the developing and adhering to good procedures for working on the guideway. In any case, the emphasis on an HSGGT system must be on avoidance of such collisions. There is no way to ensure that a person struck by a vehicle will survive; the collision is usually fatal for the person. Such collisions are not normally hazardous for the HSGGT vehicle.

The approach to collisions with maintenance equipment on the guideway (Scenario 2.4) depends on the type and weight of the equipment. The seriousness of a collision with heavy equipment can approach that of train-to-train collisions, and the only tenable strategy is avoidance. Occupation of the guideway by large maintenance equipment should be strictly controlled under the signal and train control system, to the same level of integrity as other train movements. Conversely, a "survivability" approach can be adopted for small equipment, for example a hand tool. The vehicle forward-facing structure can be designed to sustain an impact with such small equipment without serious damage to safety-critical functions of the vehicle. A judgment will have to be made regarding the size or weight of maintenance equipment that could pose a serious threat to an HSGGT vehicle in a collision. Any equipment exceeding the specified size or weight threshold must be subject to strict guideway occupation control.

A dual approach to collisions with rock and debris on the guideway (Scenario 2.5) is appropriate. Collisions with rock and debris should be avoided to the extent possible, but it should be recognized that there is no completely effective way of eliminating such collisions. The HSGGT vehicle should be designed to sustain an impact with an object of moderate weight on the guideway at full speed, and at the same time all reasonably practical strategies for avoidance should be followed. Avoidance approaches include use of an elevated guideway, provision of screens at bridges over the guideway to prevent objects from being dropped on the guideway, and daily inspections of the guideway prior to starting service. However, there is no reliable way of detecting the presence of obstructions on the guideway other than visual inspection.

It is possible to detect objects as they are falling onto the guideway by using "fragile wire" detectors. These detectors can be installed at over-guideway bridges, or wherever intrusions might be expected, and can be an effective and reliable means of collision avoidance, except when an approaching HSGGT vehicle or train is too close to be stopped at the time of intrusion.

The situation with regard to an overrun at the end of a guideway (Scenario 2.6) is similar to that for collisions between trains, Scenario Group 1. High speed overruns must be avoided: it is not possible to render them survivable. Slower speed overruns could occur, if slower speed operation under manual control is permitted, and should be rendered survivable. Avoidance and survivability techniques are as for Scenario Group 1.

Encroachments of another railroad or highway vehicle onto the HSGGT guideway or damage to a guideway structure (Scenario 2.7) can occur as a result of an accident or the presence of an inadequately secured vehicle on an adjacent highway or guideway. The highest potential for such events occurs when the HSGGT vehicles share a right-of-way with other forms of transportation, or in the case of a wheel-on-rail HSGGT, when tracks are shared with other types of trains. A collision with an obstructing vehicle at high speed has the potential for being a very serious accident, and it will be difficult or impossible to design the HSGGT vehicle or train to survive such an event. Therefore, the emphasis, as with all high speed, large object collisions, must be on avoidance. Avoidance strategies include provision of adequate lateral separation between the

HSGGT guideway and other highways or guideways; use of physical barriers such as berms, ditches, and walls; guideway elevation; and provision of an intrusion detection system such as a fragile wire detector.

It is not possible to completely prevent an HSGGT vehicle from being struck by small arms gunfire (Scenario 2.8). Thus, such events must be made survivable by ensuring that glazing and the outer skin of the vehicle cannot be penetrated by the bullet.

It is also not possible to prevent collisions with birds and other small objects flying above the guideway. Therefore, such impacts must be made survivable by imposing suitable impact performance requirements on forward-facing glazing and other surfaces. The FAA 1.9 kg (4 lb) bird-strike or the UIC 1 kg missile requirements are potentially suitable impact performance criteria.

### **Scenario Group 3: Collisions with Dissimilar Vehicles and Trains on the Same Guideway**

Collisions with dissimilar vehicles and trains on the same guideway can occur when wheel-on-rail HSGGT vehicles or trains share track with conventional passenger or freight trains. The points made in the discussion for collisions between similar vehicles or trains (Scenario Group 1) applies to this group, but with the difference that a greater emphasis on survivability may be warranted, depending on the collision avoidance features of the proposed operation and the size and weight of other trains operating on the same track.

Under present FRA regulations, speeds up to 127 km/h (79 mph) under manual control and up to 177 km (110 mph) with ATC are permitted. The ATC is not required to have the capabilities of a full ATP system. If the HSGGT vehicle is operated with no restrictions, it should exhibit a survivability performance comparable to existing modern U.S. rail passenger vehicles in collisions with conventional U.S. trains to meet the "equivalent safety" requirement.

Alternatively, the maximum speed of the HSGGT vehicle could be restricted to reduce the severity of any collision, or an improvement to collision avoidance installations on the line over which the HSGGT train operates could be undertaken. In any case, if the HSGGT does not meet conventional U.S. railroad vehicle survivability requirements, it will be necessary to demonstrate that the required overall safety performance is provided by a proposed combination of operating parameters and collision avoidance and accident survivability features.

### **Group 4 Scenarios: Single Vehicle Events**

Single vehicle events include derailments of wheel-on-rail trains, or loss of support and/or guidance of maglev vehicles or trains. Single vehicle events are usually caused by a failure of a safety-critical vehicle component or subsystem, or a failure of a guideway component. Loss of support or guidance could be followed by a collision with a structure adjacent to the guideway.

The consequences of single vehicle events that do not involve a collision with an adjacent structure tend to be less severe than a collision between vehicles or trains at a comparable speed, but are still unacceptable at very high speeds (over 200 km/h (125 mph)). Therefore, the collision avoidance approach must be taken. Experience on existing high speed rail lines in France and Japan has demonstrated that meticulous inspection and maintenance of vehicles and

the guideway can ensure freedom from derailments caused by vehicle or guideway defects. Equivalent maintenance and inspection procedures will be essential on all HSGGT systems. Use of an ATP system should prevent accidents caused by exceeding applicable speed limits.

For wheel-on-rail HSGGT systems that operate partially on the existing rail system there is a choice of strategies. A more rigorous track and vehicle inspection and maintenance program could be implemented to reduce accident probability, as has been done on the North East Corridor between Washington and Boston, or HSGGT speed could be restricted to reduce accident severity. In any case, the survivability features of the train necessary to ensure adequate performance in collisions probably would be equally effective in derailments at comparable speeds.

## **APPENDIX A**

### **U.S. SERIOUS RAILROAD ACCIDENT DATA**

This appendix provides tabulations of data on serious railroad accidents in the United States. All the data is derived from NTSB reports, and generally all mainline railroad accidents to passenger trains over the period 1970-1990 on which NTSB reports are available are included.

Two tables are provided. Table A1 contains collisions between trains on track, and Table A2 includes derailments in which only one train was involved. As far as is possible, the post-accident position and damage to rail vehicles is summarized, and an attempt is made to estimate the average acceleration experienced during the accidents. These results must be interpreted with considerable caution. They are based on estimates from the narrative descriptions and illustrations in the NTSB reports of the amount of damage sustained by vehicles and the distance between where the accident occurred and where vehicles came to rest. However, they serve to illustrate the typical orders of magnitude that is experienced in a U.S. mainline railroad accident.

For each accident, the tables provide the following information.

- Identity of accident
- Number of vehicles, weight and speed of trains involved in the accident
- Attitude of and damage to vehicles after accident
- Number of occupants, fatalities, and injuries
- Estimates of accelerations and energy dissipated in collisions



**Table A-1. Analysis of Collisions Between Trains**

Ref No	Accident Date  NTSB Report No.	Consist Data Train 1			Consist Data Train 2			Energy Calculation			Accelerations			Damage to Vehicles	Casualty Information Both Trains		
		Train Type			Train Type			Total Prior to Collision 10 <sup>6</sup> ft-lb	Dissipated in Collision 10 <sup>6</sup> ft-lb	Dissipated After Collision 10 <sup>6</sup> ft-lb	During Collision		After Both Trains		No of People on Trains	Fatalities	Injuries
		Locos + Cars	Gross Weight Tons	Speed MPH	Locos + Cars	Gross Weight Tons	Speed MPH				Train 1	Train 2					
1	8/20/69 70-3	Commuter M.U.			Commuter M.U.			43.3	32.8	10.5	0.76g	2.29g	0.25g	Lead car of Train 1 overrode lead car of Train 2 for 50 ft, after failure of underframe. No crushing elsewhere. Note few occupants in Train 2.	73	3	41
		3 Cars	180	30 reverse	9 Cars	540	30										
2	10/30/72 73-5	Commuter M.U.			Commuter M.U.			64.3	38.9	25.4	1.12g	1.45g	N/A	Lead car of Train 2 overrode rear car of Train 1 for 40 ft. Ten ft of lead car of Train 2 destroyed.	1200 approx	45	332
		4 Cars	268	10 reverse	6 Cars	346	52										
3	1/2/75 75-8	Commuter M.U.			Commuter M.U.			33.7	3.8	29.9	Approx 1.25g	Approx 2.18g	0.05g	Little damage.	1550 approx	0	265
		10 Cars	680	15	6 Cars	390	30										
4	8/5/75 76-3	Loco Hauled Passenger			Loco Hauled Freight			44.26	19.34	24.92	Approx 1.2g	Approx 0.8g	0.09g	End car of passenger train buckled. Little other damage. Many injuries in dining car.	N/A	1	62
		2	760	0	5 Locos 11 Cars	1060	25										
5	8/1/75 76-5	Rapid Transit			Rapid Transit			9.43	5.18	4.24	Approx 1.36g	Approx 1.67g	N/A	Train 1 crushed about 3 ft, Train 2 6 ft. Little other damage.	800 approx	0	154
		0+4	220	0	0+4	180	28										

Note: Metric Conversions: 1 ton = 0.91 tonnes, 10<sup>6</sup> ft-lb = 4.45 MN

**Table A-1. Analysis of Collisions Between Trains (continued)**

Ref No	Accident Date  NTSB Report No.	Consist Data Train 1			Consist Data Train 2			Energy Calculation			Accelerations			Damage to Vehicles	Casualty Information Both Trains		
		Train Type			Train Type			Total Prior to Collision 10 <sup>6</sup> ft-lb	Dissipated in Collision 10 <sup>6</sup> ft-lb	Dissipated After Collision 10 <sup>6</sup> ft-lb	During Collision		After Both Trains		No of People on Trains	Fatalities	Injuries
		Locos + Cars	Gross Weight Tons	Speed MPH	Locos + Cars	Gross Weight Tons	Speed MPH				Train 1	Train 2					
6	10/17/75 76-7	Intercity M.U. (Metroliner)			Commuter M.U. (Silverliner)			15.33	10.12	5.21	1.02g	1.98g	N/A	Train 1 little damage. Train 2 crushed about 10 ft with some override.	N/A	0	25
		0+6	435	0	0+5	255	30										
7	1/9/76 76-9	Rapid Transit			Rapid Transit			6.61	3.92	2.69	1.25g	1.82g	0.15g	Train 1 crushed 3 ft. Train 2 crushed 7 ft. Anti climber engaged, no override.	N/A	1	381
		0+6	160	0	0+4	110	30										
8	7/13/76 77-4	Commuter M.U.			Commuter M.U.			10.02	6.01	4.01	0.56g	0.83g	N/A	Train 1 modest damage. Train 2 crushed 15 ft. Speed estimate (25 mph) questionable.	161	2	30
		0+6	360	0	0+4	240	25										
9	1/9/78 79-3	Intercity			Commuter M.U.			3.61	2.82	0.79	0.89g	2.9g	-	Minor crushing of Train 2 lead vehicle.	321	0	176
		1+14	850	0	0+4	240	15?										
10	10/12/79 80.3	Freight			Intercity			132.6	-	0.85g	-	-	Intercity loco and first freight train loco destroyed. First intercity car overturned, others little damaged.	230	2	44	
		3+40	Approx 2400	0	1+5	580	58.5										
11	10/16/79 80.5	Commuter M.U.			Commuter M.U.			12.12	3.74	8.38	1.35g	2.7g	-	Minor crushing of impacting cars.	N/A	1	462 (28 serious)
		0+9	540	0	0+4	240	28										

Note: Metric Conversions: 1 ton = 0.91 tonnes, 10<sup>6</sup> ft-lb = 4.45 MN

Table A-1. Analysis of Collisions Between Trains (continued)

Ref No	Accident Date  NTSB Report No.	Consist Data Train 1			Consist Data Train 2			Energy Calculation			Accelerations			Damage to Vehicles	Casualty Information Both Trains		
		Train Type			Train Type			Total Prior to Collision 10 <sup>6</sup> ft-lb	Dissipated in Collision 10 <sup>6</sup> ft-lb	Dissipated After Collision 10 <sup>6</sup> ft-lb	During Collision		After Both Trains		No of People on Trains	Fatalities	Injuries
		Locos + Cars	Gross Weight Tons	Speed MPH	Locos + Cars	Gross Weight Tons	Speed MPH				Train 1	Train 2					
12	10/12/79 80-03	Amtrak			Freight			131.4	124.8	6.1	2.2g	0.2g	0.01g	Loco to loco collision. Passenger loco overrode freight loco 34 ft.	220	2 (on freight loco)	44
		1 Loco 5 Cars	565	59	2 Locos 41 Cars	5559	0										
13	10/16/79 80-05	Commuter M.U.			Commuter M.U.			660	9.9	561	0.9g	5.1g	0.90g	Cab to cab rear end collision. No override, stayed in line.	N/A	1	462 (431 minor)
		12 Cars	684	38	2 Cars	121	0										
14	4/2/80 80-08	Amtrak Loco-hauled			Freight			4892	157.5	331.7	0.3g	0.15g	N.A	Loco to loco collision. Loco cabs override on Amtrak. Amtrak cars 1-10 derailed, upright in line. Cars 11-18 not derailed.	125	0	120
		21 Locos 18 Cars	2740	0	5 Locos 65 Cars approx	5979	35										
15	8/11/81 82-01	Loco-propelled Pass			Freight			10.6	10.6	0	0.25g	0.15g	0	Head-on loco to cab collision. Cab car overrode loco.	70	4	28
		4 Cars 1 Loco	281	19	1 Loco 4 Cars	403	12										
16	7/23/84 85-09	Amtrak Loco Hauled			Amtrak Loco Hauled			55.42	54.8	0.6	1.2g	1.0g	N/A	Head-on loco to loco collision. All cars upright and in line. Crushing at ends only.	113	0	87
		Loco 5 Cars	401	30	Loco 7 Cars	521	30										

Note: Metric Conversions: 1 ton = 0.91 tonnes, 10<sup>6</sup> ft-lb = 4.45 MN

**Table A-1. Analysis of Collisions Between Trains (continued)**

Ref No	Accident Date  NTSB Report No.	Consist Data Train 1			Consist Data Train 2			Energy Calculation			Accelerations			Damage to Vehicles	Casualty Information Both Trains		
		Train Type			Train Type			Total Prior to Collision 10 <sup>6</sup> ft-lb	Dissipated in Collision 10 <sup>6</sup> ft-lb	Dissipated After Collision 10 <sup>6</sup> ft-lb	During Collision		After Both Trains		No of People on Trains	Fatalities	Injuries
		Locos + Cars	Gross Weight Tons	Speed MPH	Locos + Cars	Gross Weight Tons	Speed MPH				Train 1	Train 2					
17	1/21/85 86-13	Commuter M.U.			Commuter M.U.			16.2	10.8	5.4	2.0g	4.0g	N/A	Head-on cab to cab. Vestibule of cabs crushed. All cars upright and in line.	113	0	87
		4 Cars	240	30	2 Cars	120	15										
18	5/7/86 87-02	Loco hauled commuter train with cab car leading and loco at rear			Cut of cars from an intermodal freight train			29.2	25.7	3.5	1.5g			Cab car of commuter train collided with rear TOFC car of freight train. Significant local damage to cab car but no gross crushing. All cars stayed in line.	555	0	153
		1 Loco 4 Cars	450	22	0 Locos 48 Cars	330	0										
19	1/4/87 88-01	Amtrak Loco-hauled passenger			Light Engine Consist			645	368	277	4g	-	2g head 1g rear	Loco to loco collision. Passenger train damage: Locos: extensive damage. Cars 1-3 across track: extensive crushing. Cars 4-9 upright, jackknifed, cars 10-12 upright, in line.	674	16	174
		2 Locos 12 Cars	844	1-7	3 Locos 0 Cars	407	0										

Note: Metric Conversions: 1 ton = 0.91 tonnes, 10<sup>6</sup> ft-lb = 4.45 MN

Table A-2. Analysis of Derailments

Ref. No.	Accident Date	Train Data			Cause	Position of Derailed Vehicles		Casualty Information			Deceleration	
	NTSB Report	No. Vehicles	Weight (Tons)	Speed		Vehicle	Position	People on Train	Fatalities	Injuries	Vehicles	Deceleration
1	June 28, 1969 70-1	1 loco 18 cars	1365	84 mph	Track Panel Shift	Loco + cars 1-7 cars 8-12 cars 13-15 cars 16, 17 car 18	On track  Derailed, in line On side, in line Tilted, in line Derailed, in line	551 + crew	1	144	Loco + cars 1-12 cars 13-18	.079g .225g
2	Jan. 27, 1970 71-1	3 loco 10 cars	1115	65 mph	Track Panel Shift	3 locos + cars 1 & 2 cars 3-5 car 6  car 7 car 8 cars 9, 10	On track  Derailed in line On side, down embankment Overturned Upright, derailed Overturned	120 approx.	3	50	Loco + cars 1-5  cars 6-10	0.036g 0.202g
3	June 10, 1971 72/5	4 locos 15 cars	1556	90 mph	Locomotive wheelset failure	loco 1, 2 loco 3, 4 cars 1-7 cars 8-11 cars 12-14	Overturned Derailed in line On side, jackknifed Upright, jackknifed Derailed in line	N/A	11	163	locos rear of train	0.26g 0.19
4	July 5, 1974 75/1	3 locos 18 cars	1678	77 mph	Broken rail	locos + cars 1-5 cars 6-12 cars 13-16 cars 17, 18	On track  Derailed in line On side in line On side in line	N/A	1	103	locos + cars 1-12 cars 13-16 cars 17,18	0.06g 0.06g 0.10g

Note: Metric Conversions: 1 ton = 0.91 tonnes, 10<sup>6</sup> ft-lb = 4.45 MN

**Table A-2. Analysis of Derailments (continued)**

Ref. No.	Accident Date	Train Data			Cause	Position of Derailed Vehicles		Casualty Information			Deceleration	
	NTSB Report	No. Vehicles	Weight (Tons)	Speed		Vehicle	Position	People on Train	Fatalities	Injuries	Vehicles	Deceleration
5	Oct. 1, 1975 76/6	2/385 2 locos 12 cars	1130	60 mph	Rail roll-over	loco 1 locos + car 1 car 2  cars 3-6  car 7 cars 8, 9 cars 10, 11 car 12	On track Derailed coupled in line Derailed, coupled leaning 45° Derailed, coupled on side Upright, jackknifed Jackknifed, on side Derailed in line On track	69	0	31	locos + cars 1-6 cars 7-12	0.13g  0.12g
6	June 30, 1970 77/3	2 locos 11 cars	1066	88 mph	Rail roll-over overspeed	2 locos + car 1 cars 2-4 car 5 (diner)  cars 6-11	Derailed, in line Derailed in line Jackknifed, on side, coupler parted Derailed in line	160	1 track worker	45 on train, 6 track workers	Whole train	0.22g
7	Dec. 16, 1976 77/8	2 locos 11 cars	1015	53 mph	Rail rollover	loco 1 loco 2 + cars 1-6 cars 7-9 cars 10, 11	On track  Derailed in line On side in line Derailed in line	197	0	63	locos + cars 1-6 cars 7-11	0.07g 0.09g

Note: Metric Conversions: 1 ton = 0.91 tonnes, 10<sup>6</sup> ft-lb = 4.45 MN

Table A-2. Analysis of Derailments (continued)

Ref. No.	Accident Date	Train Data			Cause	Position of Derailed Vehicles		Casualty Information			Deceleration	
	NTSB Report	No. Vehicles	Weight (Tons)	Speed		Vehicle	Position	People on Train	Fatalities	Injuries	Vehicles	Deceleration
8	Feb. 24, 1978 78/6	2 locos 43 cars + auto-racks	2765	45 mph	Axle failure on loco	loco 1 loco 2, cars 1-4 cars 5, 6 cars 7-13  cars 14-21 cars 22-43	On track Derailed in line Derailed in line Derailed jack-knifed couplers parted Some tracks derailed On track	534	0	25	locos + cars 1-4 train after car 13	0.07g 0.059g
9	Dec. 3, 1978 79/4	4 locos 8 cars	1180	80 mph	Excessive speed on curve	loco 1 locos 2, 3  loco 4 cars 1-5  cars 6-8	On track Separated, derailed in line Jackknifed, overridden Extensive structural crushing, esp. cars 1, 4, 5 Derailed in line	87	6	41	4th loco cars 1-5 cars 6-8	0.56g 0.3-0.5g 0.27g
10	Mar. 28, 1979 79/7	2 locos 12 cars	900	80 mph	Broken overheated wheel on car 1	locos + cars 1-3 cars 4-8 cars 9-12	On track  Derailed in line On side in line	109	0	48	Whole train	0.13g

Note: Metric Conversions: 1 ton = 0.91 tonnes, 10<sup>6</sup> ft-lb = 4.45 MN

Table A-2. Analysis of Derailments (continued)

Ref. No.	Accident Date	Train Data			Cause	Position of Derailed Vehicles		Casualty Information			Deceleration	
	NTSB Report	No. Vehicles	Weight (Tons)	Speed		Vehicle	Position	People on Train	Fatalities	Injuries	Vehicles	Deceleration
11	Oct. 2, 1979 80-4	3 locos 17 cars	1813	78 mph	Excessive speed in curve	locos car 1 car 2 cars 3-8 car 10  car 11 cars 12, 13 cars 14-16 car 17	On side in line On side jack-knifed Upright jack-knifed Derailed in line Upright, moved past 8/9 In line on side Jackknifed on side Derailed in line On track	177	2	69	Locos cars 2-8 cars 9, 10 cars 13-17	0.37g 0.29g 0.25g 0.21g
12	March 14, 1980 80-06	2 locos 8 cars	1280	37	Rail rollover	locos cars 1-3 cars 4, 5 cars 6-8	Derailed Part overturned On side Upright, derailed	115	N/A	N/A	All	0.06g
13	Nov. 15, 1983 85-01	2 locos 9 cars	935	76	Rail failure	locos cars 1-5 car 6 cars 7-9	On track On track Tilted 30° On side	162	4	72	Last 3	0.45g
14	May 3, 1984 85-03	3 locos 18 cars	1740	79	Broken axle on 3rd loco	locos 1 + 2 loco 3 + car 1 cars 2-10 cars 11-18	On track Derailed in line Derailed, jackknifed Derailed in line	293	0	52	Cars 2-10	0.07g
15	July 7, 1984	2 locos 13 cars	1045	59	Culvert wash-out	locos car 1 cars 2-6  cars 6, 7 cars 8-13	On side Upright derailed Jackknifed, some rollover Derailed upright On track	294	5	259	Cars 2-6 Cars 7-13	0.35g to 1.4 g (worst car) 0.25g

Note: Metric Conversions: 1 ton = 0.91 tonnes, 10<sup>6</sup> ft-lb = 4.45 MN



Table A-2. Analysis of Derailments (continued)

Ref. No.	Accident Date	Train Data			Cause	Position of Derailed Vehicles		Casualty Information			Deceleration	
	NTSB Report	No. Vehicles	Weight (Tons)	Speed		Vehicle	Position	People on Train	Fatalities	Injuries	Vehicles	Deceleration
16	Oct. 9, 1986 87-06	2 locos 15 cars	1200	70	Excess speed through turnout	locos cars 1-3  cars 4-10  cars 11-15	Derailed, on side Jackknifed, cars 1, 2 rolled Derailed upright, in line On track	233	1 (on loco)	30 (5 serious)	locos, cars 1-3 cars 4-15	0.37g 0.45g 0.19g
17	April 23, 1990 91-05	3 locos 16 cars	1398	77	Buckled track	loco + cars 1-8 cars 9-16	On track Derailed upright in line	?	0	86	cars 9-16	0.14g

Note: Metric Conversions: 1 ton = 0.91 tonnes, 10<sup>6</sup> ft-lb = 4.45 MN

## REFERENCES

1. *Shared Right-of-Way Safety Issues*. FRA report to be published, 1992.
2. Bing, A., *An Assessment of High-Speed Rail Safety Issues and Research Needs*, FRA Report, DOT/FRA/ORD - 90/04, December 1990.
3. "Le Premier Train Anti-Crash," *La Vie du Rail* (France) No. 2323, 12 December 1991.
4. "17 October Collision a Melun," *La Vie du Rail* (France) No. 2316, 24 October 1991.
5. "Safety Spending to Rise by a Third," *Railway Gazette International*, April 1989.
6. "Melun; Publication du Rapport d'Enquete" (Melun, Publication of the enquiry report), *La Vie du Rail* (France) No. 2336, March 1992.
7. "Derailment near Polmont, Scottish Region," *Modern Railways* (UK), May 1985.
8. "Clapham Report," *Modern Railways* (UK), December 1989.
9. "Elements of Safety," *Modern Railways* (UK), February 1989.
10. *German High-Speed Maglev Train Safety Requirements - Potential for Application in the United States*, Federal Railroad Administration report DOT/FRA/ORD - 92-02, February 1992.
11. Hope, Richard, "Rational Spending on Safety Brings Results," *Railway Gazette*, May 1992.
12. "Statistical Abstract of the United States," U.S. Department of Commerce, 1992, Table 665.

## Serial Publications and Databases

- S1 "Accident/Incident Bulletin," Calendar years 1980-1990. U.S. Department of Transportation, Federal Railroad Administration (Annual Publication).
- S2 "Railroad Accident/Incident Database," Calendar years 1985-1990. U.S. Department of Transportation, Federal Railroad Administration (Annual database of railroad accidents and incidents available on tape).
- S3 *Railroad Accident Reports*, National Transportation Safety Board (Irregular publication, several per year).
- S4 "FAA Statistical Handbook of Aviation," Calendar Year 1989. U.S. Department of Transportation. Federal Aviation Administration (Annual Publication).
- S5 *Transportation in America: a statistical analysis of transportation in the United States*. ENO Transportation Foundation Inc. (Annual Publication).
- S6 "National Urban Mass Transportation Statistics - Section 15 Annual Report" U.S. Department of Transportation, Federal Transit Administration (Annual Publication)

