



U.S. Department
of Transportation
**Federal Railroad
Administration**

Safety of High Speed Guided Ground Transportation Systems

Office of Research
and Development
Washington, D.C. 20590

Collision Avoidance and Accident Survivability Volume 2: Collision Avoidance

Arthur D. Little, Inc.
Acorn Park
Cambridge, MA

Parsons Brinckerhoff Quade
& Douglas, Inc.
Atlanta, GA

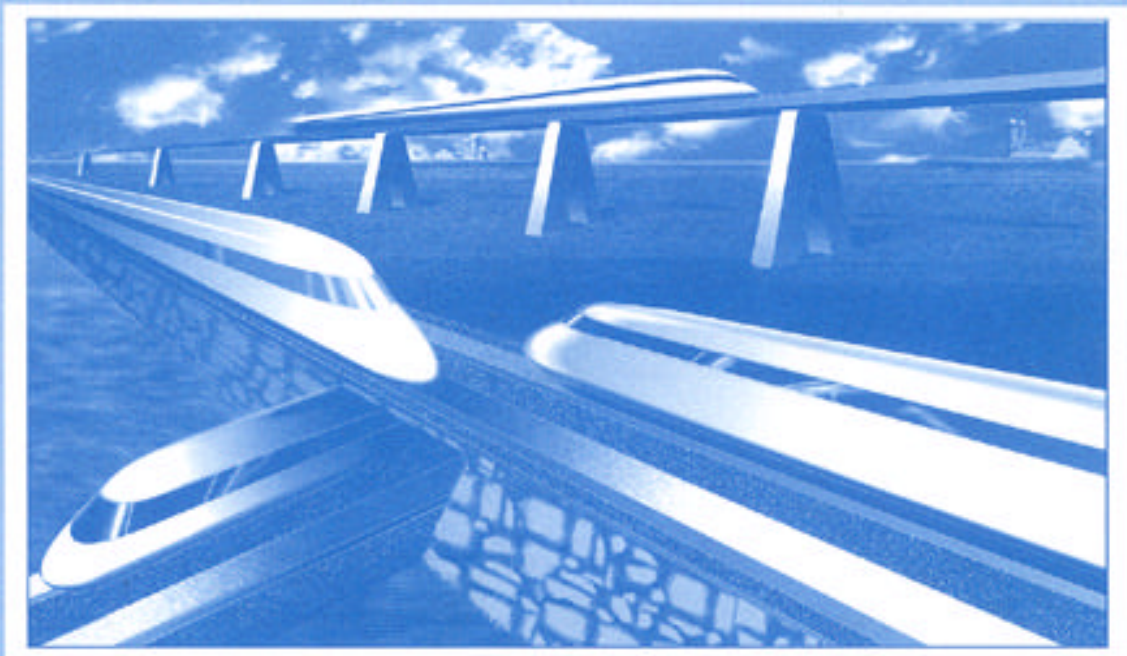

DOT/FRA/ORD-93/02.II
DOT-VNTSC-FRA-93-2.II

Final Report
March 1993

This document is available to the
public through the National Technical
Information Service, Springfield, VA 22161

NOTICE

This document is disseminated under the sponsorship of the Department of Transportation in the interest of information exchange. The United States Government assumes no liability for its contents or use thereof.

NOTICE

The United States Government does not endorse products or manufacturers. Trade or manufacturers' names appear herein solely because they are considered essential to the object of this report.

REPORT DOCUMENTATION PAGE

Form Approved
OMB No. 0704-0188

Public reporting burden for this collection of information is estimated to average 1 hour per response, including the time for reviewing instructions, searching existing data sources, gathering and maintaining the data needed, and completing and reviewing the collection of information. Send comments regarding this burden estimate or any other aspect of this collection of information, including suggestions for reducing this burden, to Washington Headquarters Services, Directorate for Information Operations and Reports, 1215 Jefferson Davis Highway, Suite 1204, Arlington, VA 22202-4302, and to the Office of Management and Budget, Paperwork Reduction Project (0704-0188), Washington, DC 20503.

1. AGENCY USE ONLY (Leave blank)		2. REPORT DATE March 1993	3. REPORT TYPE AND DATES COVERED Final Report May 1991 – September 1992	
4. TITLE AND SUBTITLE Safety of HSGGT Systems: Collision Avoidance and Accident Survivability Volume 2: Collision Avoidance			5. FUNDING NUMBERS RR393/R3015	
6. AUTHOR(S) John Harrison, et al.				
7. PERFORMING ORGANIZATION NAME(S) AND ADDRESS(ES) Arthur D. Little, Inc. Parsons Brinckerhoff Quade & Douglas, Inc. Acorn Park Atlanta, GA Cambridge, MA 02140-2390			8. PERFORMING ORGANIZATION REPORT NUMBER DOT-VNTSC-FRA-93-2.II	
9. SPONSORING/MONITORING AGENCY NAME(S) AND ADDRESS(ES) U.S. Department of Transportation Research and Special Programs Administration Volpe National Transportation Systems Center Kendall Square, Cambridge, MA 02142-1093			10. SPONSORING/MONITORING AGENCY REPORT NUMBER DOT/FRA/ORD-93/02.II	
11. SUPPLEMENTARY NOTES This research is sponsored by the Federal Railroad Administration, Office of Research and Development, Washington, DC 20590				
12a. DISTRIBUTION/AVAILABILITY STATEMENT This document is available to the public through the National Technical Information Service, Springfield, VA 22161			12b. DISTRIBUTION CODE	
13. ABSTRACT (Maximum 200 words) This report is the second of four volumes concerned with developing safety guidelines and specifications for high-speed guided ground transportation (HSGGT) collision avoidance and accident survivability. The overall approach taken in this study is to first formulate collision scenarios to which an HSGGT system may be exposed. Then existing U.S. and foreign rules, regulations, standards, and practices concerned with either preventing the occurrence of a collision, or mitigating the consequences of a collision are reviewed, together with pertinent practices from other forms of transportation, leading to the formulation of guidelines and specifications for collision avoidance and accident survivability. The volume, addressing collision avoidance, describes the features of signal and train control systems used in existing high-speed rail, conventional rail and mass transit systems, and other measures to prevent collisions such as prevention of right-of-way intrusions. A description is provided of the interaction between collision avoidance system characteristics and capabilities, and HSGGT system capacity and reliability. Finally, guidelines are developed for collision avoidance systems to be applied to HSGGT systems in the United States.				
14. SUBJECT TERMS Transportation, safety, maglev, high-speed rail, high-speed guided ground transportation			15. NUMBER OF PAGES 138	
			16. PRICE CODE	
17. SECURITY CLASSIFICATION OF REPORT Unclassified	18. SECURITY CLASSIFICATION OF THIS PAGE Unclassified	19. SECURITY CLASSIFICATION OF ABSTRACT Unclassified	20. LIMITATION OF ABSTRACT	

METRIC/ENGLISH CONVERSION FACTORS

ENGLISH TO METRIC

METRIC TO ENGLISH

<p>LENGTH (APPROXIMATE)</p> <p>1 inch (in) = 2.5 centimeters (cm) 1 foot (ft) = 30 centimeters (cm) 1 yard (yd) = 0.9 meter (m) 1 mile (mi) = 1.6 kilometers (km)</p>	<p>LENGTH (APPROXIMATE)</p> <p>1 millimeter (mm) = 0.04 inch (in) 1 centimeter (cm) = 0.4 inch (in) 1 meter (m) = 3.3 feet (ft) 1 meter (m) = 1.1 yards (yd) 1 kilometer (km) = 0.6 mile (mi)</p>
<p>AREA (APPROXIMATE)</p> <p>1 square inch (sq in, in²) = 6.5 square centimeters (cm²) 1 square foot (sq ft, ft²) = 0.09 square meter (m²) 1 square yard (sq yd, yd²) = 0.8 square meter (m²) 1 square mile (sq mi, mi²) = 2.6 square kilometers (km²) 1 acre = 0.4 hectare (he) = 4,000 square meters (m²)</p>	<p>AREA (APPROXIMATE)</p> <p>1 square centimeter (cm²) = 0.16 square inch (sq in, in²) 1 square meter (m²) = 1.2 square yards (sq yd, yd²) 1 square kilometer (km²) = 0.4 square mile (sq mi, mi²) 10,000 square meters (m²) = 1 hectare (ha) = 2.5 acres</p>
<p>MASS - WEIGHT (APPROXIMATE)</p> <p>1 ounce (oz) = 28 grams (gm) 1 pound (lb) = 0.45 kilogram (kg) 1 short ton = 2,000 pounds (lb) = 0.9 tonne (t)</p>	<p>MASS - WEIGHT (APPROXIMATE)</p> <p>1 gram (gm) = 0.036 ounce (oz) 1 kilogram (kg) = 2.2 pounds (lb) 1 tonne (t) = 1,000 kilograms (kg) = 1.1 short tons</p>
<p>VOLUME (APPROXIMATE)</p> <p>1 teaspoon (tsp) = 5 milliliters (ml) 1 tablespoon (tbsp) = 15 milliliters (ml) 1 fluid ounce (fl oz) = 30 milliliters (ml) 1 cup (c) = 0.24 liter (l) 1 pint (pt) = 0.47 liter (l) 1 quart (qt) = 0.96 liter (l) 1 gallon (gal) = 3.8 liters (l) 1 cubic foot (cu ft, ft³) = 0.03 cubic meter (m³) 1 cubic yard (cu yd, yd³) = 0.76 cubic meter (m³)</p>	<p>VOLUME (APPROXIMATE)</p> <p>1 milliliter (ml) = 0.03 fluid ounce (fl oz) 1 liter (l) = 2.1 pints (pt) 1 liter (l) = 1.06 quarts (qt) 1 liter (l) = 0.26 gallon (gal) 1 cubic meter (m³) = 36 cubic feet (cu ft, ft³) 1 cubic meter (m³) = 1.3 cubic yards (cu yd, yd³)</p>
<p>TEMPERATURE (EXACT)</p> <p>$[(x-32)(5/9)] \text{ } ^\circ\text{F} = y \text{ } ^\circ\text{C}$</p>	<p>TEMPERATURE (EXACT)</p> <p>$[(9/5)y + 32] \text{ } ^\circ\text{C} = x \text{ } ^\circ\text{F}$</p>

QUICK INCH - CENTIMETER LENGTH CONVERSION

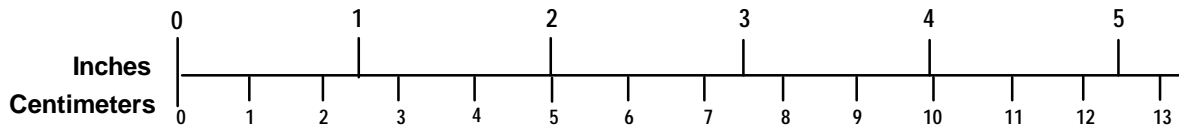

QUICK FAHRENHEIT - CELSIUS TEMPERATURE CONVERSION

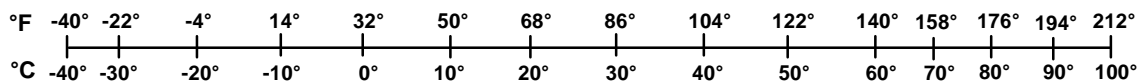

For more exact and or other conversion factors, see NIST Miscellaneous Publication 286, Units of Weights and Measures.
 Price \$2.50 SD Catalog No. C13 10286

Updated 6/17/98

PREFACE

In recent years there has been increased interest in high speed guided ground transportation (HSGGT). In May of 1991 the state of Texas awarded a franchise for the construction of a high speed rail system linking Dallas/Ft. Worth, San Antonio, and Houston, and in January of 1992 a detailed franchise agreement was signed for construction of a system using the French Train à Grande Vitesse (TGV). In June of 1989 the Florida High Speed Rail Commission (now part of the Florida Department of Transportation) recommended awarding a franchise for construction of a maglev system linking Orlando airport and a major attractions area on International Drive in Orlando, and in June of 1991 a franchise agreement was signed by the state of Florida for construction of a system using the German Transrapid TR07. In November of 1992 Amtrak began testing the Swedish X2000 tilt-train on the Northeast Corridor and in 1993 Amtrak will test the German Inter-City Express (ICE) train on the Northeast corridor. In 1991 four contracts were awarded for the development of a U.S. designed maglev system, as part of the National Maglev Initiative. The Intermodal Surface Transportation Efficiency Act (ISTEA) of 1991 provides for the further development of a U.S. designed maglev system. In addition to the current active projects, there have been numerous proposals throughout the country for new high speed systems and for increasing the speeds on current rail corridors.

All of the systems proposed for operation at speeds greater than current practice employ technologies that are different from those used in current guided ground transportation systems. These different technologies include advanced signaling and control systems and lightweight car-body structures for all or most HSGGT systems. The differences in technology, along with the increased potential consequences of an accident occurring at high speeds, require assurances that HSGGT systems are safe for use by the traveling public and operating personnel.

This report on collision safety is part of a comprehensive effort by the Federal Railroad Administration (FRA) to develop the technical information necessary for regulating the safety of high speed guided ground transportation. Other areas currently being studied by the FRA as part of its high speed guided ground transportation safety program include:

- Maglev Technology Safety Assessments (both electromagnetic and electrodynamic)
- Development of Emergency Preparedness Guidelines
- Electromagnetic Field Characteristics
- Guideway Safety Issues
- Automation Safety
- Human Factors and Automation

Collision safety comprises the measures taken to avoid collision and also to assure passenger and crew protection in the event of an accident. The results of this study, presented in the four-volume report, provide a basis for evaluating the collision safety provided by a given HSGGT system. These measures must be evaluated concurrently for a coordinated, effective approach. Based on the results of this study, work is currently planned to evaluate the collision safety of a proposed system and to evaluate the effectiveness of modifications on the collision safety of an existing conventional system.

ACKNOWLEDGEMENT

The authors wish to thank David Tyrell, the Technical Monitor for this task, Robert Dorer, other staff of the Volpe National Transportation Systems Center, and Arne Bang and his colleagues at the Federal Railroad Administration for their support and assistance during this project.

Table of Contents

Section	page
1. INTRODUCTION.....	1-1
1.1 Background.....	1-1
1.2 Purpose and Overview of this Volume	1-1
1.3 History of Collision Avoidance	1-3
1.4 Current Practice and Future Development of Collision Avoidance	1-3
1.5 Report Organization.....	1-5
2. COLLISION AVOIDANCE FEATURES OF SYSTEM OPERATION	2-1
2.1 Introduction	2-1
2.2 Route Integrity	2-1
2.2.1 Train Detection	2-1
2.2.2 Interlocking Integrity	2-7
2.2.3 Route Integrity Checking	2-12
2.3 SpeedConveyance	2-12
2.3.1 Wayside Signals	2-13
2.3.2 Cab Signals	2-15
2.3.3 Speed Code Transmission	2-15
2.4 Overspeed Protection	2-19
2.5 Summary of Collision Avoidance Features	2-23
2.6 System Architecture	2-23
3. VEHICLE, GUIDEWAY AND WAYSIDE DESIGN TECHNIQUES FOR COLLISION AVOIDANCE	3-1
3.1 Introduction	3-1
3.2 Design Techniques for Collision Avoidance Systems	3-1
3.2.1 Right-of-Way Design	3-1
3.2.2 Guideway Design	3-5
3.2.3 Grade Crossing Design	3-7
3.2.4 Vehicle Systems	3-10
3.3 Enforcement and Human Action	3-14
3.4 Vehicle Malfunction Safety Systems	3-15
3.4.1 Wayside	3-15

Table of Contents (continued)

Section	Page
3.4.2 Onboard Vehicle.....	3-16
3.5 Human Role in Support of Collision Avoidance	3-16
3.5.1 Maintenance and Testing Practices	3-17
3.5.2 Human Action Limitations	3-18
3.5.3 Predictable Intrusion	3-18
3.5.4 Unpredictable Intrusion	3-19
3.6 Summary	3-19
4. EFFECT OF COLLISION AVOIDANCE MEASURES ON SYSTEM OPERATION	4-1
4.1 Introduction	4-1
4.2 Route Integrity Measures	4-2
4.2.1 Train Detection	4-2
4.2.2 Interlocking.....	4-8
4.2.3 Interlocking Architecture	4-9
4.3 Signaling Methods.....	4-10
4.3.1 Intermittent Cab Signaling.....	4-10
4.3.2 Continuous Cab Signaling	4-11
4.4 ATP Speed Enforcement	4-11
4.4.1 Onboard Speed Control	4-13
4.4.2 Train Braking.....	4-13
4.5 Guideway Design Measures	4-17
4.5.1 Grade Crossing Warning Devices	4-17
4.5.2 Intrusion and Mechanical Malfunction Detection Devices	4-18
4.6 Summary	4-18
5. RECOMMENDED GUIDELINES FOR COLLISION AVOIDANCE EVALUATION	5-1
5.1 Introduction.....	5-1
5.2 Collision Scenarios Reviewed	5-1

Table of Contents (continued)

Section	Page
5.2.1 Group 1: Train-Train (Same Track) Collision Avoidance.....	5-1
5.2.2 Group 2: Train-Obstruction (Intrusion) Collision Avoidance.....	5-2
5.2.3 Group 3: Train-Dissimilar Train Collision Avoidance	5-4
5.2.4 Group 4: Single Train Collision Avoidance	5-6
5.3 Evaluation of HSGGT System Requirements	5-6
5.4 Evaluation of Specific Technological Approaches	5-8
5.4.1 Train Detection, Speed Conveyance and Enforcement	5-8
5.4.2 Interlocking, Route, and Guideway Integrity	5-10
5.4.3 Vital Logic Processing	5-10
5.4.4 Guideway Design	5-12
5.4.5 Grade Crossing Design	5-12
5.4.6 Vehicle Systems	5-13
5.4.7 Intrusion Protection	5-14
5.4.8 End-of-Guideway Design	5-15
5.5 Other Considerations.....	5-15
5.5.1 Reliability	5-15
5.5.2 Maintainability.....	5-16
5.5.3 Maintenance	5-16
5.5.4 Training	5-16
5.6 Evaluation of System Performance	5-16
5.6.1 Reliability Estimating Techniques.....	5-17
5.6.2 System Evaluation	5-18
APPENDIX A.	HISTORY OF COLLISION AVOIDANCE
APPENDIX B.	THE SELTRAC SYSTEM
APPENDIX C.	U.S. VITAL MICROPROCESSOR INTERLOCKING
APPENDIX D.	SOFTWARE APPLICATION IN THE UNITED STATES
APPENDIX E.	TRAIN BRAKE INSPECTION AND TESTING.....
APPENDIX F.	SYSTEM PERFORMANCE ESTIMATING TECHNIQUES
APPENDIX G.	U.S. STANDARDS AND SPECIFICATIONS
APPENDIX H.	BIBLIOGRAPHY

List of Figures

Figure		Page
2.1	Audio Frequency Track Circuit.....	2-3
2.2	Microprocessor Controlled Coded Track Circuits	2-4
2.3	Phase Selective Track Circuit	2-5
2.4	AC Vane Relay Track Circuit	2-6
2.5	SELTRAC Moving Block - Safety Separation Control Strategy for Vehicles	2-14
2.6	Three-Block, Three-Aspect Wayside Signal System (Without Train Stops or Other ATP)	2-16
2.7	Three-Block, Three-Aspect Wayside Signal System With Some Form of ATP	2-17
2.8	Cab Signal System Schematic	2-18
2.9	Cab Signal System with Automatic Overspeed Protection	2-21
3.1	View of 4 Disc Brakes on a Wheel/Axle Assembly	3-12
4.1	Minimum Headway in a Fixed Block System	4-3
4.2	Minimum Headway in a Moving Block System.....	4-5
4.3	Intermittent Cab Signaling Impact on Capacity and Operations	4-12

List of Tables

Table		Page
1.1	History of Collision Avoidance in the United States	1-4
2.1	Application and Effectiveness of Collision Avoidance Techniques for HSGGT Operation.....	2-24
2.2	Train Control System Architecture: Foreign HSGGT Examples	2-26
2.3	Train Control System Architecture: U.S. Heavy Rail Transit Installations	2-27
2.4	Train Control System Architecture: U.S. Light Rail Transit Installations	2-28
2.5	Train Control System Architecture: U.S. AGT Transit Installations	2-30
3.1	Guideway, Vehicle and Wayside Design Features.....	3-20
4.1	Distance Traveled vs. Speed	4-7
4.2	Braking Time and Distance Tables	4-15
4.3	Emergency Braking Time and Distance Tables with Cumulative Reaction Time and Distance.....	4-16

Abbreviations and Terminology

Many abbreviations are in common use for railroad organizations and high-speed rail systems and their components. This list provides a convenient reference for those abbreviations used frequently in this report. Note that some abbreviations, particularly those used for different train control systems (ATC, ATCS, ATP, etc.), may not have the same meaning for all users. Commonly accepted meanings are given.

AAR	Association of American Railroads.
ASTREE	Automatization du Suivi en Temps (French on-board train control system).
ATC	Automatic Train Control - systems which provide for automatic initiation of braking and/or other train control functions. ATP and ATO are sub-systems of ATC.
ATO	Automatic Train Operation - a system of automatic control of train movements from start to stop. Customarily applied to rail rapid transit operations.
ATCS	Advanced Train Control Systems - a specific project of the AAR to develop train control systems with enhanced capabilities.
ATP	Automatic Train Protection - usually a comprehensive system of automatic supervision of train operator actions. Will initiate braking if speed limits or signal indications are not obeyed. All ATP systems are also ATC systems.
AWS	Automatic Warning System - a simple cab signalling and ATC system used on British Rail.
BART	Bay Area Rapid Transit (San Francisco).
BN	Burlington Northern Railroad.
BR	British Rail.
CFR	Code of Federal Regulations.
CPU	Central Processing Unit (core unit of a microprocessor).

Abbreviations and Terminology (continued)

DB	Deutsche Bundesbahn - German Federal Railways.
DIN	Deutsche Institut for Normung - German National Standards Institute.
DLR	Docklands Light Railway, London, U.K.
EMI	Electro-Magnetic Interference - usually used in connection with the interference with signal control circuits caused by high power electric traction systems.
FCC	Federal Communications Commission (United States).
FRA	Federal Railroad Administration of the United States Department of Transportation.
FTA	Federal Transit Administration.
HSGGT	High-Speed Guided Ground Transportation.
HSR	High-Speed Rail.
HST	High-Speed Train - British Rail high-speed diesel- electric trainset.
ICE	Inter-City Express - a high speed train-set developed for German Federal Railways consisting of a locomotive at each end and approximately 10 intermediate passenger cars.
ISO	International Standards Organization.
Intermittent	A term used in connection with ATC and ATO systems to describe a system that transmits instructions from track to train at discrete points rather than continuously.
JNR	Japanese National Railways - organization formerly responsible for rail services in Japan. Was reorganized as the Japan Railways (JR) Group on April 1, 1987, comprising several regional railways, a freight business and a Shinkansen holding company.

Abbreviations and Terminology (continued)

JR	Japan Railways - see JNR.
LCX	Leakage co-axial cables - LCX cables laid along a guideway can provide high quality radio transmission between the vehicle and wayside. LCX is more reliable than air-wave radio, and can be used where air waves cannot, for example, in tunnels.
LGV	Ligne a Grand Vitesse - French newly-built high- speed lines. See also TGV.
LRC	Light Rapid Comfortable. A high-speed tilt-body diesel-electric train-set developed in Canada.
LZB	Linienzugbeeinflussung - Comprehensive system of train control and automatic train protection developed by German Federal Railways.
MU	Multiple Unit. A train on which all or most passenger cars are individually powered and no separate locomotive is used.
MARTA	Metropolitan Atlanta Rapid Transit Authority.
NBS	Neubaustrecken - German Federal Railway newly- built high-speed lines.
NTSB	National Transportation Safety Board (U.S.).
PATCO	Port Authority Transit Corporation (Lindenwold Line).
PSE	Paris Sud-Est. The high-speed line from Paris to Lyon on French National Railways.
RENFE	Rede Nacional de los Ferrocarriles Espanoles - Spanish National Railways.
SBB	Schweizerische Bundesbahnen - Swiss Federal Railways.
SELTRAC	Moving-block signaling system developed by Alcatel, Canada.
SSI	Solid State Interlocking.

Abbreviations and Terminology (continued)

SJ	Statens Jarnvagar - Swedish State Railways.
SNCF	Societe Nationale des Chemin de Fer Francais - French National Railways.
TGV	Train a Grand Vitesse - French High-Speed Train. Also used to refer to complete French high-speed train system.
UIC	Union Internationale de Chemins de Fer.
UMTA	Urban Mass Transportation Administration of the U.S. Department of Transportation. The name of this agency has now been changed to the Federal Transit Administration (FTA).
US or U.S.	United States.
Vital	A vital component or system performs a critical function in such a manner as to ensure that a single anticipated failure cannot present an unsafe condition.
VNTSC	Volpe National Transportation Systems Center.
WMATA	Washington Metropolitan Area Transit Authority.

1. INTRODUCTION

1.1 BACKGROUND

This is the second volume of a four-volume report documenting the findings of a research program sponsored by the Federal Railroad Administration (FRA) in the areas of collision avoidance and accident survivability of high-speed guided ground transportation (HSGGT) systems.

- Volume 1 describes collision threats HSGGT systems must contend with, and recommends guidelines for assessing the overall accident risks associated with operating such systems, and the ways of controlling those risks.
- Volume 2 reviews state-of-the-art of collision avoidance systems; includes an evaluation of the effect of collision avoidance measures upon system operation; and provides guidelines for applying these measures and evaluating their applicability and effectiveness.
- Volume 3 reviews the state-of-the-art of accident protection technology; describes techniques used in assessing crash -worthiness performance; outlines how this technology and techniques can be applied to HSGGT vehicles; and develops guidelines for the evaluation of HSGGT accident survivability performance.
- Volume 4 describes safety specifications that address the collision avoidance and accident survivability aspects of HSGGT systems -- the end product of this research.

1.2 PURPOSE AND OVERVIEW OF THIS VOLUME

The purpose of this volume is to define broadly the collision avoidance system requirements for HSGGT system safety. Collision avoidance comprises a family of functions whose purpose is to assure the safety of train movements by preventing collisions and derailments. Collision avoidance involves *physical characteristics* (such as grade separation), *operational characteristics* (such as segregating freight and passenger traffic), and *system features* (such as signal and control systems, hotbox detectors and other safety devices).

Two categories of collision avoidance techniques are addressed in this volume:

- Integral features of system operation, such as a signal system (discussed in Chapter 2)
- Other design techniques that are built into the vehicle, guideway or wayside design to help avoid collisions (discussed in Chapter 3).

The current state-of-the-art, both in the U.S. and world-wide, is discussed vis-a-vis the four groups of collision scenarios defined in Volume 1, which include:

1. *Collisions between similar high-speed trains or vehicles on the same guideway.*

2. *High-speed collisions with an obstruction on the guideway, or with an object propelled at the train.* This group includes intrusions from an adjacent guideway whether in a shared right-of-way or not.
3. *Collisions between dissimilar trains or vehicles on the same guideway.* This group includes collisions between a high-speed train and another slower-speed train of a different type or between a high-speed train and a maintenance vehicle on the same guideway.
4. *Single-train events,* usually involving a loss of support and guidance, followed by a sudden stop. Such events can be accompanied by collisions with structures adjacent to the guideway. Examples of single-train events include derailments of conventional wheel-on-rail trains and the unintended set-down of a maglev vehicle.

Current U.S. collision avoidance techniques employed by designers of guided ground transportation system vary with system type, age, traffic characteristics, and regulatory requirements. Existing U.S. systems are generally of two types -- railroads (including freight, intercity passenger, and commuter rail, regulated by FRA through the Code of Federal Regulations) and transit systems (including light rail, heavy rail, and peplemover type systems, regulated primarily by state agencies, not by the federal government). The Association of America Railroads (AAR) publishes a communications and signals manual that establishes standards that are generally followed by U.S. railroads and transit authorities.

The highest speed revenue passenger railroad operation in the U.S. is the Amtrak Northeast Corridor, an electrified 200 km/h (125 mph) line that handles a mix of intercity passenger, commuter and freight trains. The Corridor employs conventional signal system hardware, including cab signals and on-board braking enforcement. Trains are operated in accordance with rules published by Amtrak governing the movement of trains and engines. Trains are dispatched and operated manually in accordance with the rules. Crews are required to have complete control of their trains at all times. If allowable signal speeds are exceeded and a warning ignored, brakes are automatically applied.

This heavy reliance on manual control in the Northeast Corridor is in sharp contrast with modern transit systems in the U.S. -- such as BART, MARTA WMATA and PATCO -- that are largely automated. These systems have only limited operator involvement (e.g., door operation at station stops) except in emergencies when operators can take over train control according to prescribed rules , if required. Otherwise, under normal circumstances, these systems operate with minimal human involvement. All speed commands (including acceleration, braking and speed enforcement) are carried out automatically depending on track/guideway civil speed limits, train separation requirements and other operating conditions. These transit systems incorporate most of the collision avoidance features that will be required for safe HSGGT operation in the U.S.

As the state-of-the-art of train control evolves, it is likely that an increasing number of safety-related functions will be monitored, managed, and controlled by microprocessors, reducing reliance on human actions or responses to operating conditions. This trend will presumably improve safety and reliability despite increasing the complexity of the overall system. Continuing increase in complexity of automated systems and microprocessors reduces reliance on human

operators (also on human inspection of vehicles and guideways), but increases the difficulty of assessing safety and reliability, and of proving that necessary safety levels are being achieved. The challenge is to quantify the benefit of such systems.

Human error or intentional intervention (e.g., by improper maintenance methods, vandalism, overriding of safety systems, or bad judgment) -- has always played a part in the effectiveness of collision avoidance systems. Notwithstanding such problems introduced by humans, collisions are typically the result of an inadequacy or a malfunction in one of the collision avoidance sub-systems.

1.3 HISTORY OF COLLISION AVOIDANCE

Historically, collision avoidance techniques have lagged behind advances in motive power and track/guideway technologies. In the U.S., there have not been significant advances in collision avoidance techniques since the early 1950s, even though other system design features have undergone dramatic improvements. Indeed, the first 150 years of development of collision avoidance technique occurred mostly through hindsight and trial and error. Current systems engineering and analysis methods, however, will allow future collision avoidance system design for HSGGT systems to proceed on a logical and predictable basis that will provide high levels of reliability and safety.

Table 1.1 summarizes the collision and avoidance system development milestones in the U.S. to date. Interested readers are referred to Appendix A for a more thorough discussion of the collision avoidance developments historically.

1.4 CURRENT PRACTICE AND FUTURE DEVELOPMENT OF COLLISION AVOIDANCE

Current U.S. techniques vary largely based upon system age and economics, speed and traffic volume upon the guideway, and acceptance of safety performance levels. All collision avoidance systems rely upon vital, fail-safe techniques, with most systems relying upon closed-loop circuitry or the force of gravity to produce a safe effect in the event of system failure.

The principal functions or components of a collision avoidance system are as follows:

Train Detection. Train detection is the foundation of all non-vehicle systems vital to preventing collisions. If train presence is not seen by a system, either no train is present (hence, no risk of collision) or a train is present but no associated systems operate to prevent a collision (resulting in high collision probability). Typically train presence locks all system functions that can prevent a threat to safe train movement upon the guideway through a complex system of vital circuitry.

Table 1.1. History of Collision Avoidance in the United States

1824 TO 1844	Train separation accomplished by strict adherence to timetables or simple signaling by observation.
1842	Telegraph introduced to convey train information for signaling beyond line-of-sight.
1872	First electric track circuits introduced to provide train detection. Automatic block signaling introduced.
1880	ATP type signal began using train stops that activated the brakes if the engineer disregarded a stop signal.
1901-1909	Mechanical stop, typically used today, invented and widely accepted.
1922	Intrusion detectors (slide fences) used to place stops that prevent collisions caused by rock slides.
1925	First "cab-no-wayside" signaling used. Cab signals widely used to complement system. Inductive train stops introduced. The technological level used in 1925 is the current level used today on most U.S. railroads, though many components have been updated with current available hardware.
1930 to 1951	1925 level provides satisfactory performance at speeds up to 176 km/h (110 mph).
1951 to 1992	Most innovations are replacement technologies that provide functions similar to those of older methods but reduce labor and maintenance requirements.

Signals. Signals inform the engineer of maximum safe speed based upon track occupancy conditions that are monitored by vital logic. Monitored conditions include train presence (or potential presence) and integrity of all vital systems along the route that could present an unsafe condition for train movement. Generally U.S. transit system signal systems also incorporate civil speed limits in the system logic. U.S. railroad practice, however, does not. Today, most systems have some level of checking for an engineer's response to signals (ATP), or potential to respond ("deadman"), with many including automatic brake application if the engineer fails to react in the proper manner.

Fault Tolerance. Microprocessors are now often used to provide vital results similar to relay based systems. Absence of fault-tolerance, however, often requires rules and policies to be used for train movement authority, with absence of all, or portions of the collision avoidance system in operation. Typically, most U.S. vital systems protect against only single failures, and multiple

failures can void a system's fail safety. Track/guideway intrusion is seldom protected against, is most often handled by signage and fencing.

U.S. Systems. Systems developed in the U.S. can provide fully automatic train operation with human intervention being solely for standby, but such an approach is seldom used. Usually a train operator has movement control of train, and most systems operation is limited to providing override of the operator's action if he fails to react in the proper manner.

Foreign Systems. Systems developed overseas currently are procedurally similar to U.S. systems, though the equipment used differs and additional integrity is achieved at some levels. Some Foreign HSGGT systems use a vital train-wayside communications method which is not currently used in the U.S. on conventional railroad and transit systems. Highway grade crossings are often barrier closures (though not impenetrable) and integrated with a speed command system to the train. Unlike those used in the U.S., foreign vital microprocessor approaches include fault-tolerant techniques that provide uninterrupted system operation in the event of many common failure occurrences, limiting the necessity for by-passing safety functions.

An effective collision avoidance system for HSGGT will interface vital state-of-the-art technologies in such a manner that predictable (and probable) failures will not result in a collision, to a probability level commensurate with current standards. Fault tolerance should provide uninterrupted vital system operation regardless of operational failures. Speed enforcement is required and it will be more effective in a system at high speeds if initiated by the system with human backup, as opposed to being initiated by conventional human action with enforcement backup. The potential exists for "intelligent braking" that can provide varying brake rates based upon the collision threat introduced. The effective interfacing of the vital sub-systems, in combination with adequate attention to the human factors involved, will result in a collision avoidance system that will meet or exceed expected levels of safety.

1.5 REPORT ORGANIZATION

The contents of the following chapters are described briefly below:

Chapter 2, *Collision Avoidance Features of System Operation*, describes train control functions and approaches used in carrying out these functions.

Chapter 3, *Vehicle, Guideway, and Wayside Design Techniques for Collision Avoidance*, reviews methods of collision avoidance other than through train control systems, (i.e., through other design means, such as grade separation).

Chapter 4, *Effect of Collision Avoidance Measure on Systems Operation*, discusses reliability, maintenance requirements, and other effects of the collision avoidance systems features.

Chapter 5, *Recommended Guidelines for Collision Avoidance Evaluation*, reviews the four collision categories, evaluates HSGGT collision avoidance system requirements, discusses reliability, maintainability, testing and training needs, and develops a methodology for evaluating the performance of proposed collision avoidance elements in an HSGGT system.

2. COLLISION AVOIDANCE FEATURES OF SYSTEM OPERATION

2.1 INTRODUCTION

There are three main functions within an HSGGT signal and train control system that are of vital importance to the safety of both the crew and passengers on board, as well as to the prevention of damage to the equipment. These are:

- *The guarantee of route integrity.* This function can be accomplished now through either the traditional method of hard-wired relay interlocking, or as seen more and more in recent years, through the use of microprocessor-based (solid state) interlockings (SSI). These interlocking systems are designed to ensure that any train is given a route only when the status of switches and the location of other trains and equipment make it safe to do so.
- *"The communication of movement authority to the train" [Speed Conveyance].* This function conveys the maximum safe speed to the train and/or train operator. On most conventional railroads, this function is still performed simply by wayside signals. On many transit systems and high-speed rail systems, it is conducted by data transmitted from the wayside to the train. This data transmission may be as simple as a coded speed signal transmitted through the rail to the train or as complex as a multi-word radio frequency transmission complete with error detection codes. In some cases, the transmission system incorporates a feedback feature that verifies the proper message has been received.
- *The enforcement of safe speed.* This portion of the train control system ensures that the train does not exceed the maximum line or interlocking speed. In many instances, this function is performed by the train operator himself, but in more automatic systems, the onboard equipment may be designed for automatic brake application if the speed limit is exceeded. This function is referred to as Automatic Train Protection (ATP). The brake may be retrievable or irrevocable, and it may be at a normal service braking rate or at a higher emergency rate.

This chapter discusses route integrity, speed conveyance, and overspeed protection, i.e., the primary functions of the signaling system and train control system architecture (centralized versus localized or some combination of the two). Vehicle, guideway, and wayside design techniques for collision avoidance are covered in Chapter 3.

2.2 ROUTE INTEGRITY

2.2.1 Train Detection

Accurate real time detection of train location is essential for determining a safe route and speed within a system. It also provides for locking of guideway movement elements such as switches, and activation of additional systems such as grade crossing systems. Train detection must be fail-safe for associated systems functions to operate in a vital, fail-safe manner.

Current methods of train detection include the use of a variety of track circuits, track transponders and radio wave transmission. New methods are evolving that can supplement if not totally replace track circuits. Since any failure of detection systems creates a very high potential for collision, these systems must be highly reliable and fail safe. Speed conveyance information can be integrated with all track circuit types.

1. Track Circuits

Track circuits have been the most common method of detecting train presence since 1872. All currently accepted vital track circuits employ closed loop technology. Visual observation, loop detectors, and axle counters still exist and have their place, but will not be discussed here because they are not practical for use in an HSGGT collision avoidance system.

Many types of track circuits are used for train detection and, in many cases, for broken rail detection and/or speed code transmission. Speed code transmission can be an integral part of the track circuit or overlaid upon it. Such codes are received by onboard equipment for use by either ATP or speed indication to the train operator or both. Track circuits are normally selected on the basis of their operating environment and they can be classified into two groups:

- Audio frequency and microprocessor controlled types
- Dual element frequency and phase selective types

Audio Frequency Track Circuit (Figure 2.1)

First used on railroads for operating highway crossing devices, audio frequency track circuits were superimposed on top of existing DC track circuits to define approaches and island areas for highway crossings. Later, these circuits were developed for railroads and transit authorities where AC traction power is used and the rails provide traction power return. Audio frequency track circuits can be used for speed code transmission.

The audio frequency track circuit:

- Differs from the power frequency track circuit in that the transmitter and receiver are electronic units.
- Comes in a range of different frequencies to provide adjacent track circuit isolation.
- Usually includes a transmitter/receiver pair.
- May be modulated by a continuous low frequency tone.
- Requires no insulating track joints.

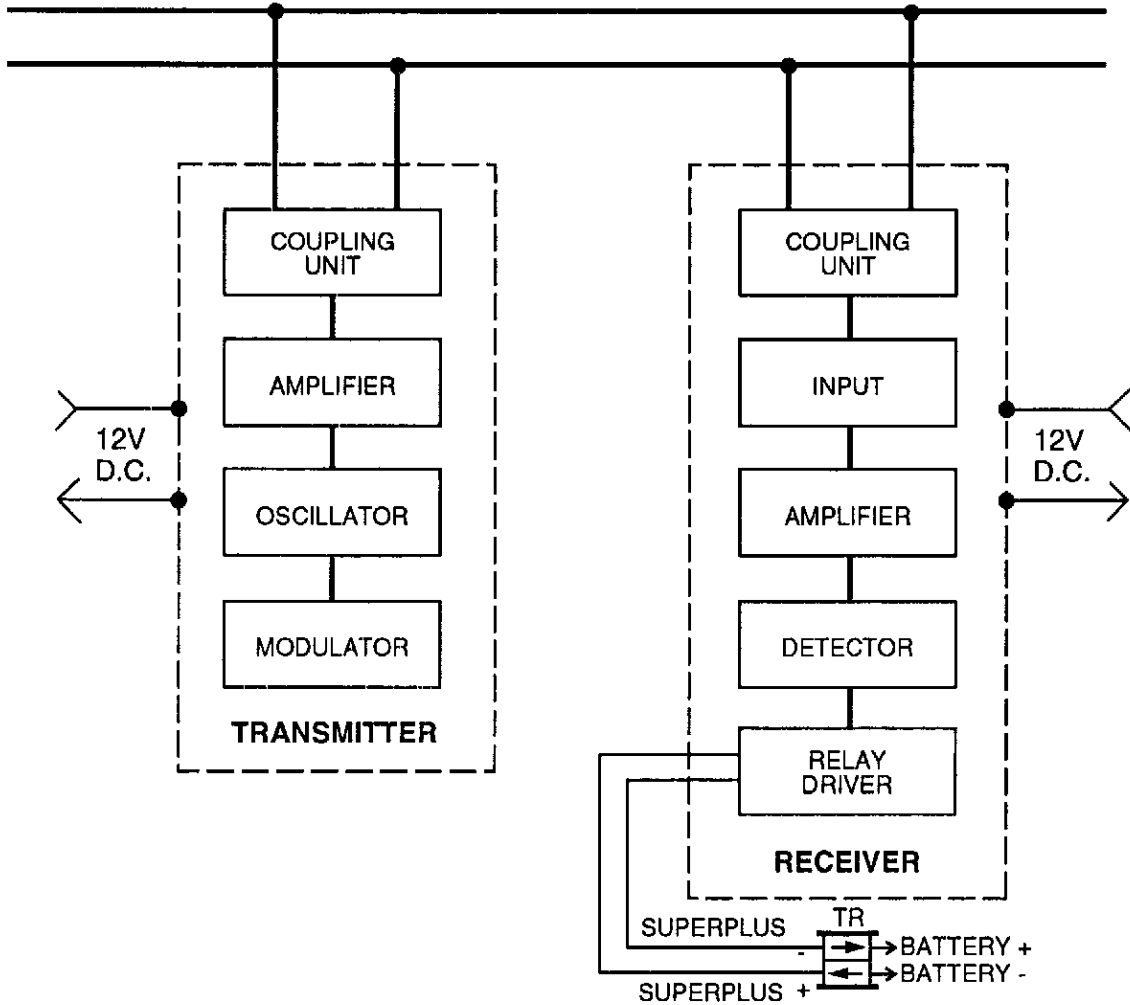

Figure 2.1. Audio Frequency Track Circuit

Microprocessor Track Circuit (Figure 2.2)

Currently, microprocessor track circuits in the U.S. are installed in a manner similar to the installation of AC track circuits. Present types require the use of insulated joints for separation, though current technologies allow alternative means of separation of track circuits.

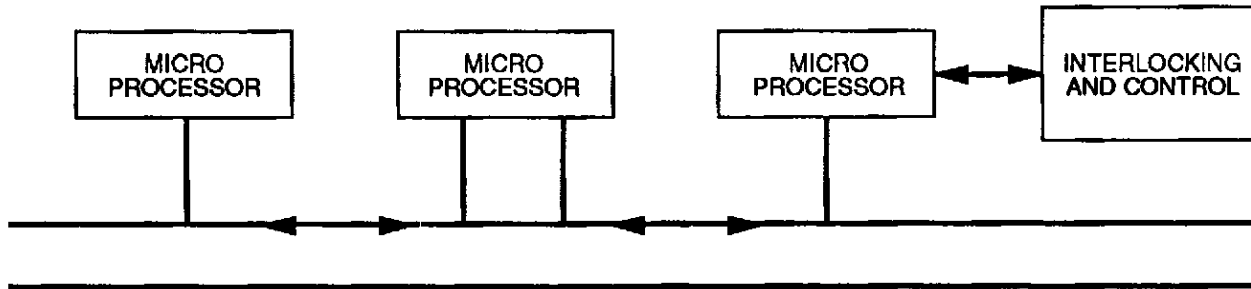

Figure 2.2. Microprocessor Controlled Coded Track Circuits

Microprocessor track circuits can also provide speed code transmission. They present several advantages in that they can:

- Transmit considerable information through the rails, instead of requiring the use of cabling alongside the right-of-way.
- Require less maintenance and be safer from vandalism than conventional relay track circuits.
- Offer superior protection from tampering by unauthorized personnel.

The potential for this type of track circuit has yet to be fully realized. The microprocessor track circuit is suited to HSGGT use, though fault-tolerance and effects of certain failure modes require consideration.

Phase Selective Track Circuit (Figure 2.3)

The phase selective track circuit, commonly used in U.S. railroad applications, operates like the conventional AC track circuit. A reference AC signal (normally in the power frequency range) is run the full length of the signaled territory. This "pilot signal" is fed to both the transmitter and receiver end of each track circuit. Because of the impedance of the rails, the signal that arrives at the receiver end of the rails is phased differently from the pilot signal fed into the rails. Hence the receiver end unit is adjusted to look for that phase difference. Whenever the phase difference is not detected, an occupancy is indicated. The transmitted signal may be modulated by a code rate transmitter and then received by a code following relay, so that both speed code transmission and occupancy detection are possible. This type of track circuit could be used on a high-speed line but it requires insulated joints, which increase the maintenance requirements, making them less desirable than some other choices.

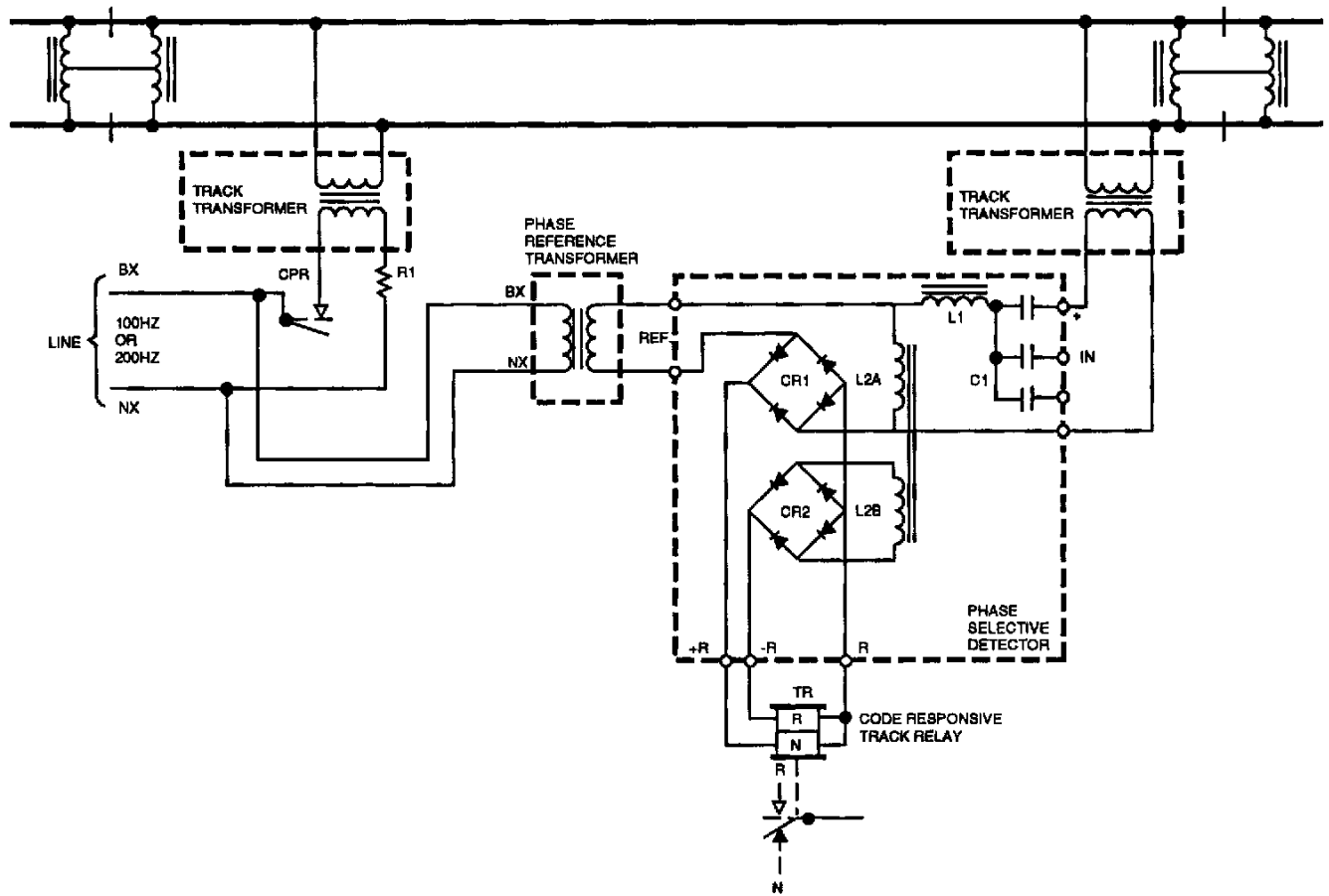

Figure 2.3. Phase Selective Track Circuit

Dual Element Track Circuit (Figure 2.4)

Dual element track circuits ensure that the wrong track relay is not energized. First introduced in 1906, this method was initially most widely used with centrifugal relays. This highly effective relay was last produced in 1972 because of high maintenance and associated costs. The AC vane relay circuit became the sole survivor of this track circuit type. The most common AC track circuits are energized at relatively low frequencies, 60 to 100 Hz., and are based upon the use of a two element vane relay. This relay is energized by two sources - a local AC current source and a track current source. These two currents must be properly phased to magnetically pull the vane upwards for a "picked" relay condition, or an unoccupied track indication. Any change in frequency or phase from either source tends to pull the vane downward and the relay drops. The frequency is chosen so as not to be affected by the propulsion frequency or its associated harmonics. A more modern variation is the TRU-II type circuit, that drives a conventional DC

type vital track relay. These types of track circuits could be used in high-speed application. They require the use of insulated joints, however, which makes them less desirable than other possible choices for reasons noted above.

DC Track Circuit

This closed track circuit, invented in 1872 and based on a very simple principle, consists of an insulated section of track with a DC relay at one end and a DC voltage source at the other end. The battery voltage is applied across the rails and the voltage at the other end picks up the relay.

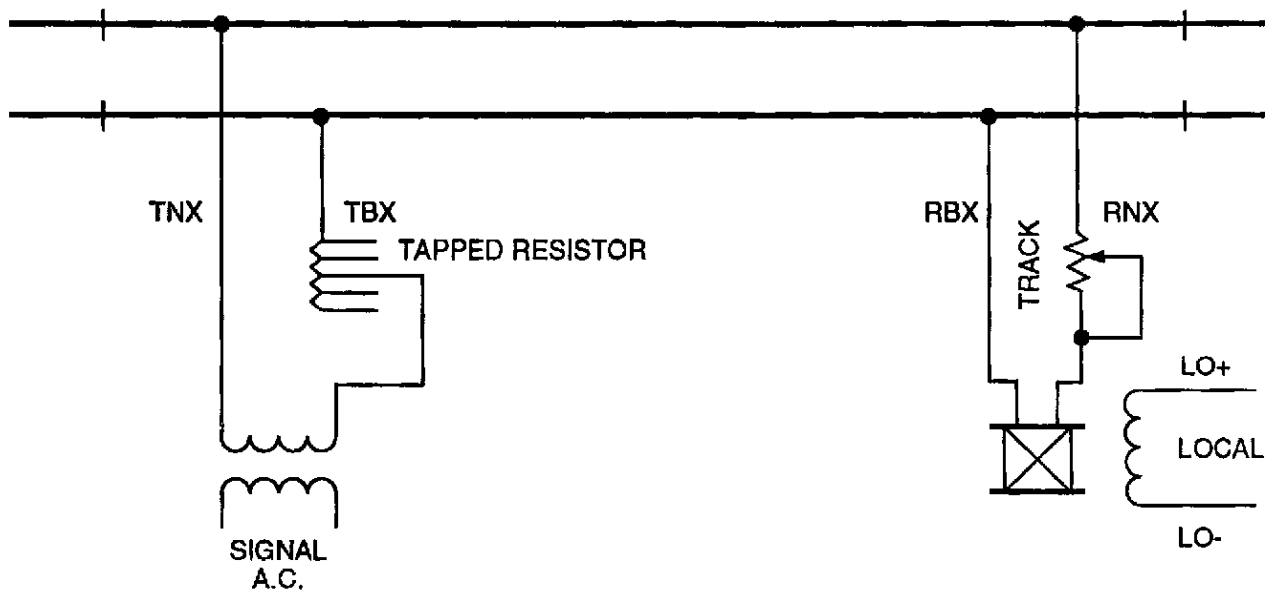

Figure 2.4. AC Vane Relay Track Circuit

A steel wheel-axle that enters the rails provides a "path of least resistance" (shunt) that ensures that the relay drops due to gravity. This closed loop, fail-safe circuitry also provides broken-rail detection because broken rails also open the circuit.

For light rail vehicles, it has been proven to be the least reliable for train detection in some circumstances and it cannot be used with conventional electric traction systems. Though its variations are used and make important contributions to collision avoidance, its use may be impractical for an HSGGT system.

2. Non-Track Circuit Train Detection Methods

Non-track circuit methods typically provide considerably more information processing capabilities than conventional track circuits. They do not provide guideway integrity checks by themselves,

so they should be supplemented by other means. Some are not in constant contact with the train in the manner of a track circuit and may require additional supporting circuits for proper train detection.

Transponders

Transponders are used in conventional speed systems in Europe for train detection and in the Transrapid maglev vehicle speed/location detection system. To be most cost-effective, the transponder is normally mounted on the track and used with an interrogator that is placed on board the train. When the train passes the transponder, it detects the identity of the transponder and transmits its location, typically by radio, back to the signal control point. If the train fails to read a transponder, location is extrapolated from the last "good" reading. Communication to the wayside is over a microwave radio link. This method of detection does not detect broken rail and requires special train equipment. Transponders are highly adaptable.

Satellite Systems

The Burlington Northern Railroad in conjunction with Rockwell International is experimenting with a system to provide train detection and speed conveyance information processing by means of satellite radio links. Presently, the system without supporting systems, does not provide accuracy of train position, but its use is not limited because of these requirements.

Onboard Detection Sensing

In France, SNCF is developing the Automatization du Suivi en Temps (ASTREE) system, in which a vehicle or train continuously calculates its position from a reference point and transmits this information to a control center. Plans call for this system to be installed and working within the next decade. The first field trial of this system was instituted in the spring of 1990. ASTREE traction units will be fitted with Doppler radar that will compute a train's speed and location within 0.1 percent. These data, as well as destination, weight, braking capacity, etc. will be radio transmitted to a control center. These transmissions may be made later via satellites. Union Pacific Railroad is experimenting with an ATCS detection system which uses a transponder as a reference with an onboard odometer to measure distance.

This type of onboard sensing and reporting is similar to the transponder method. It raises a similar question about what detection is provided if the communication method fails. A fail-safe coding and logic can be applied, and appropriately regulated, or this method could be used in conjunction with the more traditional track circuit as a backup.

2.2.2 Interlocking Integrity

An interlocking is defined as an arrangement of signal apparatus so interconnected that functions must succeed each other in a predetermined sequence, thus permitting safe train movements along a selected route without collision or derailment. An interlocking is used to route trains safely through areas with high collision potential (train-train at-grade crossings, powered switch areas, drawbridges). Interlockings may be classified as automatic, remote controlled, or locally controlled:

- *Automatic interlockings* are pre-programmed such that when an approaching train is detected they will initiate, call for, and establish the correct route in advance of the train.
- *Remotely controlled interlockings* are manually controlled by operators and/or computers at centrally located offices.
- *Locally controlled interlockings* are manually controlled at the interlocking.

All vital control circuits, the functioning of which affects safety of train operation, are designed according to the closed circuit principle. Vital interlocking circuits are designed such that if a failure is sensed, the wayside signals are set to stop, cab or speed signals are set to lowest speed command, and a stop aspect is conveyed to all affected trains. The control circuits for aspects with indications more favorable than "proceed at restricted speed" are selected through track relays and track switches in the route governed.

Interlocking integrity can be accomplished now through either the traditional method of hard-wired relay interlocking, or as seen more and more in recent years, through use of microprocessor-based interlocking. These interlocking systems are designed to ensure that any train is given a route only when the status of switches and the location of other trains and equipment make it safe to do so. The decisions upon which the integrity is ensured are based upon train detection, guideway status, and all potentially conflicting train movements. Interlocking integrity circuitry is always based upon fail-safe circuitry. Conventional powered switch machines serve both to move and to mechanically lock the switch points, while indicating position of the switch. Dependent upon the length of the movable portion, a different number of vital position checks are made before allowing a signal to be displayed for the route.

1. Interlocking Integrity Methods

Fail-safe, closed loop circuitry provides checking of position of movable guideway elements that are integrated into the signal system. Similar circuitry provides cross checks of all potential conflicting movements, thus providing total route integrity. As a result of the design of these circuits, the only inadequacy that has resulted in collision in this area is neglect a failure to provide for more than a single failure within the fail-safe circuitry (excepting human error).

Use of microprocessors to provide equivalent circuitry introduces new methods of defining fail-safe. Collisions in this area are all a result of shortcomings in other areas: inadequate testing, underqualified or overtaxed personnel, inadequate maintenance, inadequate policies or regulations, vandalism, and other areas of human intervention in these systems. Microprocessor applications introduce additional variables not addressed here. Today, guideway integrity of non-moving portions is monitored by broken rail detective track circuits and routine visual inspection. Rate of inspection and standards are relative to maximum allowed speeds.

Summary of History of Interlocking Development

Early interlockings used strictly mechanical means of providing the necessary checks for collision avoidance. Vital electrical circuits were introduced, along with the use of vital relays and locks that are positioned to be fail-safe by ensuring that gravity will open circuits or lock devices if energy is lost. This led to electro-mechanical interlocking methods that provided both mechanical

and electrical locking techniques, a method still in use today, but no longer practical for a new installation.

Current methods use either an all-relay interlocking that provides all previous mechanical checks in vital circuitry, or microprocessor interlocking techniques that essentially reproduce relay type logic using vital software programming methods. The AAR Communications and Signals Manual of Recommended Practice, 2.2.12, provides recommendations for microprocessor implementation of vital circuitry.

Vital Relay Interlocking

The basis of this interlocking system is the vital relay that is mechanically constructed so as to be vital or fail-safe, with non-weldable front contacts. Circuits are designed so that the de-energized state of the relay always results in a safe condition, bringing a train to a stop or resulting in a lower speed. The installation of a vital interlocking is verified by a breakdown test where every element of each circuit is verified to perform its intended function.

Vital relay interlockings will be present in railroads for a long time but they require a great deal of relatively expensive and bulky equipment. They are used on high-speed systems such as the TGV, the Shinkansen, and much of the ICE, but microprocessor logic is becoming more prevalent both in the United States and abroad.

U.S. Vital Microprocessor Interlocking

In the United States, two major signaling equipment suppliers (Union Switch & Signal and General Railway Signals) have developed vital microprocessor interlocking systems that follow most of the guidelines of the AAR 2.2.12. These systems have been installed in many properties across the country, including Conrail, Amtrak, Norfolk Southern, New York City Transit Authority, Washington Metropolitan Area Transit Authority, and the Chicago Transit Authority. The list grows as designers of new installations choose to use this method for its cost and maintenance savings.

Vitality for the vital microprocessor system is achieved using theoretically proven vital processor technology. The vital processor technology mimics closed loop principles with dual path programming techniques and wraparound discrete hardware. The system operates as follows:

- Dual path programming interweaves diagnostic routines and system checks within the operational data base.
- The hardware is made secure by software "loop back" monitoring, wherein the processor toggles the input and output monitor devices, or applies specific check data to the inputs and outputs, and requires a given response from these devices.
- Logic within the microprocessor detects an incorrect response and immediately specifies a "fail safe" reaction.
- The diagnostic routines detect safety critical problems within the system and/or improper system operation and take appropriate "fail-safe" action.

A more detailed description of how the system operates is presented in Appendix C.

Both single CPU and multiple CPU types are used in vital microprocessor systems:

- *Single CPUs.* Currently, all vital microprocessor systems produced for signal circuitry tasks in the U.S. use a single CPU with theoretically proven methods of checking stored and processed information to ensure system vitality.
- *Multiple CPUs.* Vital CPU based systems, with similar life and property protection tasks, have been in use by systems produced for aircraft controls, ship guidance and the like for many years in the U.S. As a general rule, such systems employ two or more CPUs that provide identical side-by-side functions, with a cross check of results and data to ensure all CPU decisions of control are correct.

The two types of systems, (i.e.: multiple, cross-checking CPUs, and single CPU-based system employing dual path processing and/or storage) merit comparison with regard to reliability and integrity:

- *The single CPU based systems* are forced to shut down to maintain vitality when a single vital error is encountered (non-fault-tolerant). This "reliability-versus-integrity" factor is unavoidable with single CPU-based systems, as any vital error encountered will and must produce the fail-safe result of removing energy from vital circuits controlled by the CPU.
- *The multiple CPU type systems* produce vitality while maintaining a very high reliability factor (fault tolerant), as vital errors can often be recovered from without compromising vitality.

While no multiple CPU-based systems are in use for train or signals systems control in the U.S., their added reliability (based on their ability to recover internally from occasional, unavoidable vital errors) is more acceptable for high-speed systems, where system shutdowns have the potential of introducing additional problems. Multiple CPU systems may have to be used in some cases, where the response to a control failure cannot be simply to halt operations.

Software Application in the U.S.

The steps in the application process are as follows:

- Interlocking logic design is defined in terms of traditional relay logic and is converted to Boolean algebraic expressions.
- The Boolean algebraic expressions are then submitted to a high-level compiler which converts Boolean algebra to machine language or applicable code that resides in EPROMs (Erasable Programmable Read Only Memory).
- The EPROMs are inserted into the vital microprocessor.
- The vital microprocessor executes the application code and performs vital interlocking responsibilities.

The executive and application programming are installed in a non-volatile memory in such a way as to preclude unintentional changes by the user.

Appendix D includes a more detailed description of the software application in the United States.

Foreign Solid State Interlocking (SSI)

Multiple CPU based systems are in use outside the U.S. for rail and Maglev systems control. The vitality is similar to U.S. systems, though it is produced by a "voting" scheme, and is achieved in a fault-tolerant manner by recent systems. Occasional errors in a CPU-based system are unavoidable currently, and only a multiple CPU system designed to produce multiple decisions for identical data can adjust to such errors with less than a shutdown of portions of vital controls. Single CPU systems ensure fail-safe vitality by shutting down portions of vital functions within not more than 1 second of an interpreted error, while multiple CPU systems are capable of recovering from momentary errors without producing fail-safe shutdowns, and without compromising fail-safe principles.

SSI was first installed in Europe, with the first successful computer-based interlockings at Goteburg (1978) and Malmo (1980), and then the first microcomputer-based interlocking produced by Dansk Signal Industry in 1980. Vitality of this system was achieved by running two independent programs, A and B, on a single microcomputer and requiring that the results agree.

BR Research and Development Division with GEC-General Signal Ltd. and Westinghouse Signals Ltd. in Great Britain have developed an SSI system based on three processors, with two of the three being used normally and the third acting as a hot standby. This type of system is also to be used on the German ICE expansion. The German Maglev Transrapid interlocking logic is provided by a fail-safe microprocessor unit based on the Siemens "SIMIS" railway signaling microprocessor, using the two-out-of-three voting procedure. One interlocking logic unit controls a specified length of guideway.

2. Interlocking Integrity Functions

The key sub-systems within an interlocking system, described below, provide integrity of movement, and collision avoidance safety. All functions that control locking and movement functions of signal appliances within an interlocking vitally insure that all related subsystems allow the operation prior to its initiation, and insure that they do so in an accepted fail-safe manner.

Time Locking

Time locking is used to ensure that a prescribed amount of time elapses before an aligned, locked route can be changed to allow a different, conflicting route. The time setting ensures that a train that has passed the approach signal will have sufficient time, if necessary, to stop before it enters the cancelled route. The time setting is based upon the worst case braking curve (longest time), thus all switch machines and other devices are locked in their present position until the time has expired.

Approach Locking

Approach locking is used to provide an immediate release of an aligned route if a train is not detected on the approach track circuit or approach limits. When a train is in the approach limits, time locking prevents an aligned route from being unlocked until a prescribed amount of time has elapsed.

Route Locking

Route locking ensures that the correct route has been aligned and locked. Route locking locks all power switch machines and signals within a route, such that as a train progresses through a route, switches in advance and under the train are locked, though switches behind the train may be released to promote efficient movement. Some type of loss-of-shunt protection is usually provided, and is required by the FRA to ensure that a route cannot be changed while a train is present.

Traffic Locking

Traffic locking ensures that direction of movement between two opposing interlockings cannot be changed once a route has been lined in one direction, or any train occupies any portion of that track area. Traffic locking circuits may be implicit or may be an integral part of signal line control circuits.

Speed Conveyance within Interlocking

After a route has been selected in a given direction, the trains operating over that route are given speed commands or signals based upon the conditions in the route. Traditional signal design allows for different speeds in a given speed code block, which may or may not correspond to the track circuit. The maximum speed command selected must be less than or equal to the governing civil speed for the track section. This interlocking function chooses the speeds necessary to prevent rear end collisions and collisions or derailments caused by excessive speed.

2.2.3 Route Integrity Checking

Prior to allowing a signal to proceed, all areas that affect safe passage must be checked to provide route integrity. This area deals with route integrity both inside and outside an interlocking, but covers route integrity beyond normal interlocking safety functions. Traffic locking, electrically locked switches, guideway integrity and other areas that provide for safe movement along the guideway are addressed.

2.3 SPEED CONVEYANCE

The use of wayside signals is the most common method of conveying allowed speed to the operator. Many collisions have resulted from wayside signals being ignored, misunderstood, vandalized, or obscured by fog or snow. Therefore, wayside signals are often complemented by cab signals that provide the operator with more immediate indications and a variety of ATP speed enforcement techniques.

Some Maglev systems employ wayside speed control techniques in which the vehicle only monitors speed/location. In this case speed conveyance is for verification and not for control purposes.

Newer systems employ inductive coupling or radio frequency communications to pass information to the train and engineer. ATP can insure speed and braking compliance, preventing collisions due to inaction by the engineer. Rules and policies must complement any speed conveyance method, not only to ensure conformity, but to provide alternative speeds and methods when any portion of the speed conveyance system is inoperative.

A fairly recent concept, moving block signaling, provides speed commands through a more precise logic, allowing shorter headways than is otherwise possible. Moving block signal systems maintain train separation closer to the required distance for safe braking than fixed block systems can. Use of a moving block approach also eliminates the extra block length distance in addition to the safe braking distance required under a fixed block approach. This moving block concept is in use in Vancouver, B.C. on the Sky Train and in London on the Docklands Light Railway. Both of these railroad systems are using SELTRAC, a transmission-based moving block system, that enforces a minimum safe separation between trains, based on the safe braking distance from the last verified position of the rear car of a preceding train (see Figure 2.5). Appendix B presents a more detailed description of the SELTRAC system.

2.3.1. Wayside Signals

Typically, rules require an operator to prepare to react to a wayside signal immediately when it becomes apparent what action is required. Issues associated with the time required to respond to wayside signals include:

- *Observance.* Signals can be obscured by weather, brush, and vandalism to the point of invisibility, and can be improperly observed, e.g., confused with other lights or as phantom aspects. (A phantom aspect results from reflected sunlight which falsely appears to illuminate a signal lens).
- *Recognition and Reaction.* Even with constant alertness, unpredictable lapses such as a sneeze can significantly extend recognition and reaction time.
- *Start of Safe Service Braking Period.* Operator braking action follows observance, recognition, and reaction delays. Signal systems are planned assuming a reaction time before braking, typically 4 seconds reaction.

Even with the use of more advanced methods than that of relying solely upon wayside signals, responsible action by the operator in manual systems is necessary for collision avoidance. Speed enforcement methods can be used in addition to wayside signals, but they cannot generally be expected to override an operator's authority until after a wayside signal has been passed. This situation potentially creates a very large difference between required emergency ATP braking and operator initiated braking. This difference grows as speeds increase, and will prevent effective use of wayside signals in an HSGGT system unless they are complemented by other means. Use

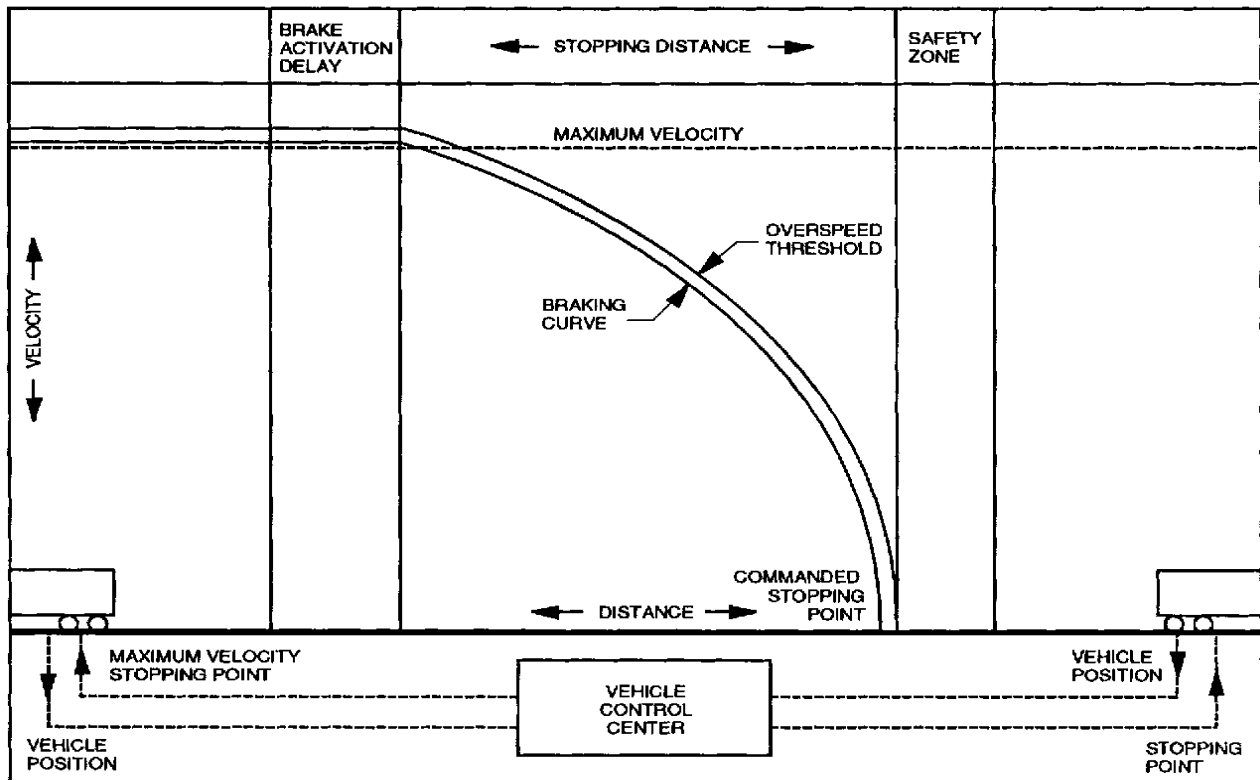

Source: SEL Division of Alcatel Canada, Inc.

Figure 2.5. SELTRAC Moving Block - Safety Separation Control Strategy for Vehicles

of ATO eliminates train operator reaction time and subsequent recognition by onboard equipment that the operator has not reacted properly.

The most common wayside signaling method uses three basic aspects. The operation of this method is depicted, with and without ATP, in Figures 2.6 and 2.7.

2.3.2 Cab Signals

Cab signals are typically used in conjunction with wayside signals to constantly indicate a level of proper speed within the train cab. As shown schematically in Figure 2.8, inductive coupling of the train system with a track-based system (that may or may not be an integral part of the track circuit) provides indications similar to a wayside signal within the cab. These systems are often interfaced with an ATP system.

A significant advantage of cab signaling is the instant indication and/or reaction in the train to route integrity, guideway integrity, or intrusion. This response does not necessarily aid in actual collision avoidance, but it can make sure that the lowest possible speed is achieved before the vandalism affects train movement. Cab signals are employed by the German ICE, Japanese Shinkansen, and French TGV systems. Another advantage is that cab signal systems can readily employ many more aspects than wayside systems and, in fact, can provide continuous speed signaling. This allows more operational flexibility and increased line capacity. For example, Amtrak is installing a new 10-aspect cab signal system from Newark, NJ to New York Penn Station to increase capacity on this heavily used two-track line.

2.3.3 Speed Code Transmission

Speed code transmission, generally performed on an intermittent basis, usually consists of a wayside antenna placed at the block boundary. This antenna transmits a speed command to a vehicle-borne antenna as it passes. The disadvantage of this system is that the train does not immediately see a change in the railroad in front and thus it is generally slower operationally. The satellite train detection system previously discussed can provide speed transmission information of a much more detailed nature.

For systems that are designed to be run completely automatically (e.g., automated people movers, the London Docklands Light Railway), the speed signal is often only seen internally by the automatic train control (ATC) equipment.

- The ATP portion of this equipment uses this information for speed enforcement, discussed in Section 3.3.2.
- The automatic train operation (ATO) portion of the equipment uses the information to control the propulsion and braking units. The ATO functions much the same as a human operator but normally with greater precision and consistency.

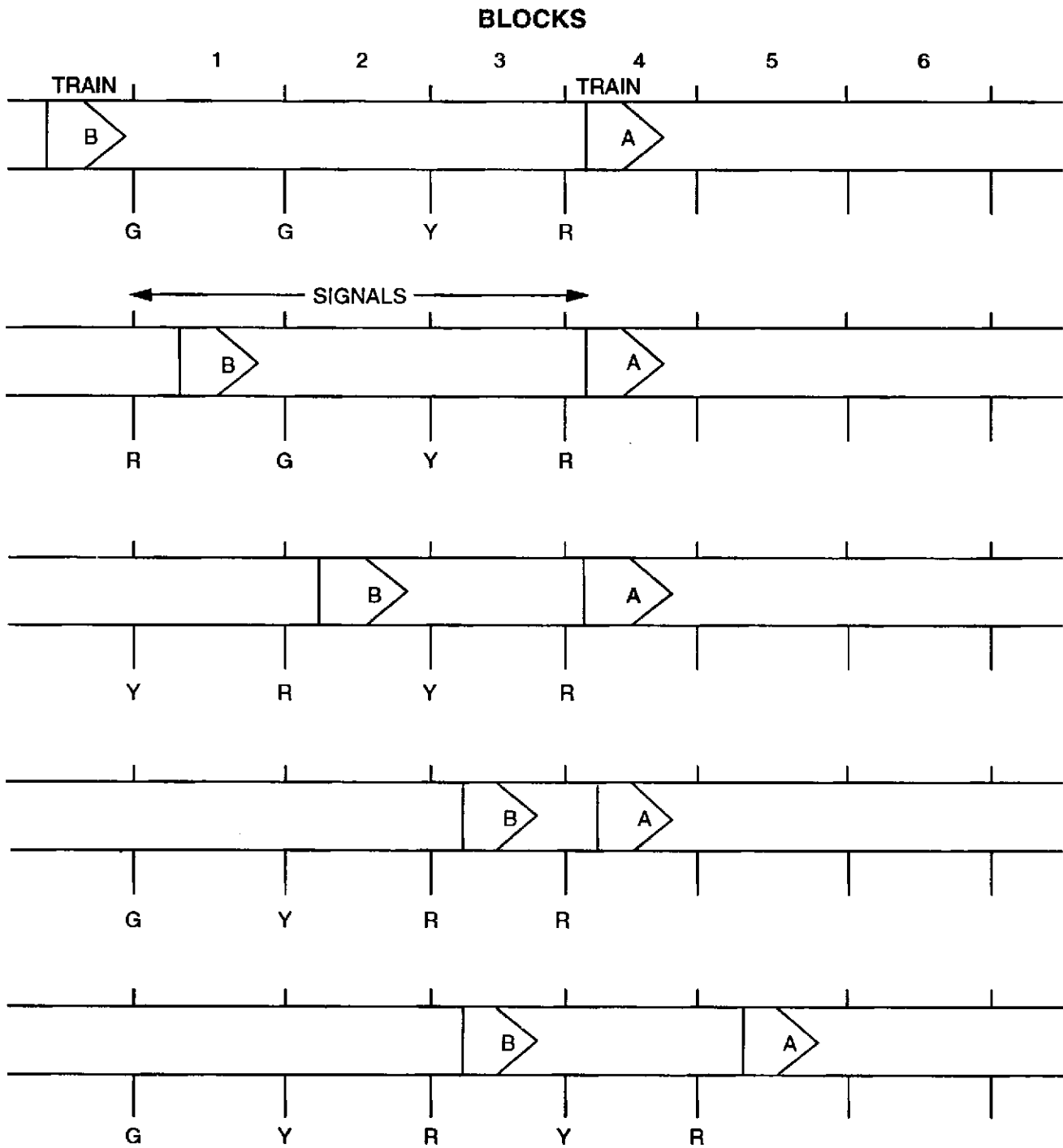

Figure 2.6. Three-Block, Three-Aspect Wayside Signal System (Without Train Stops or Other ATP)

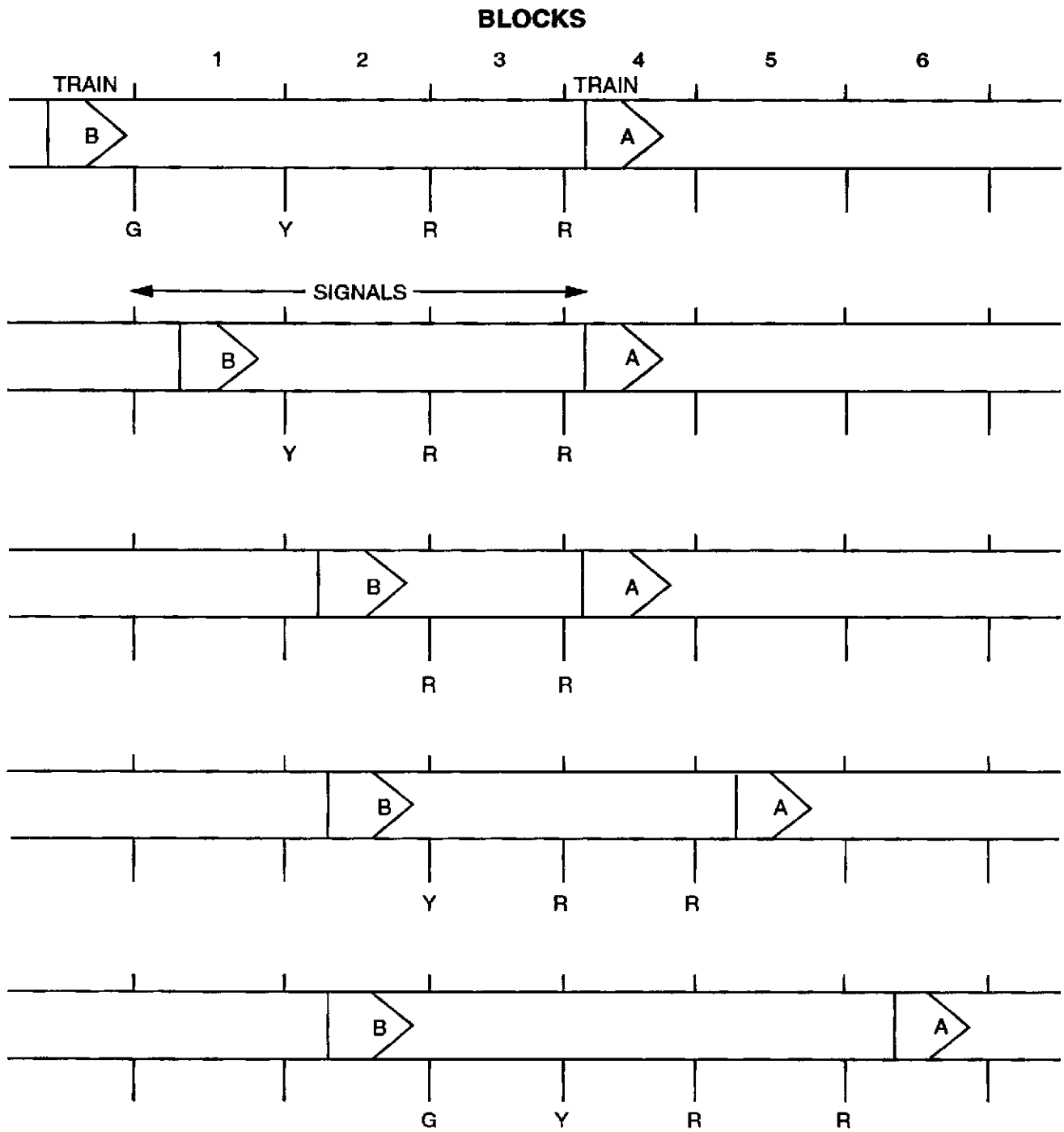
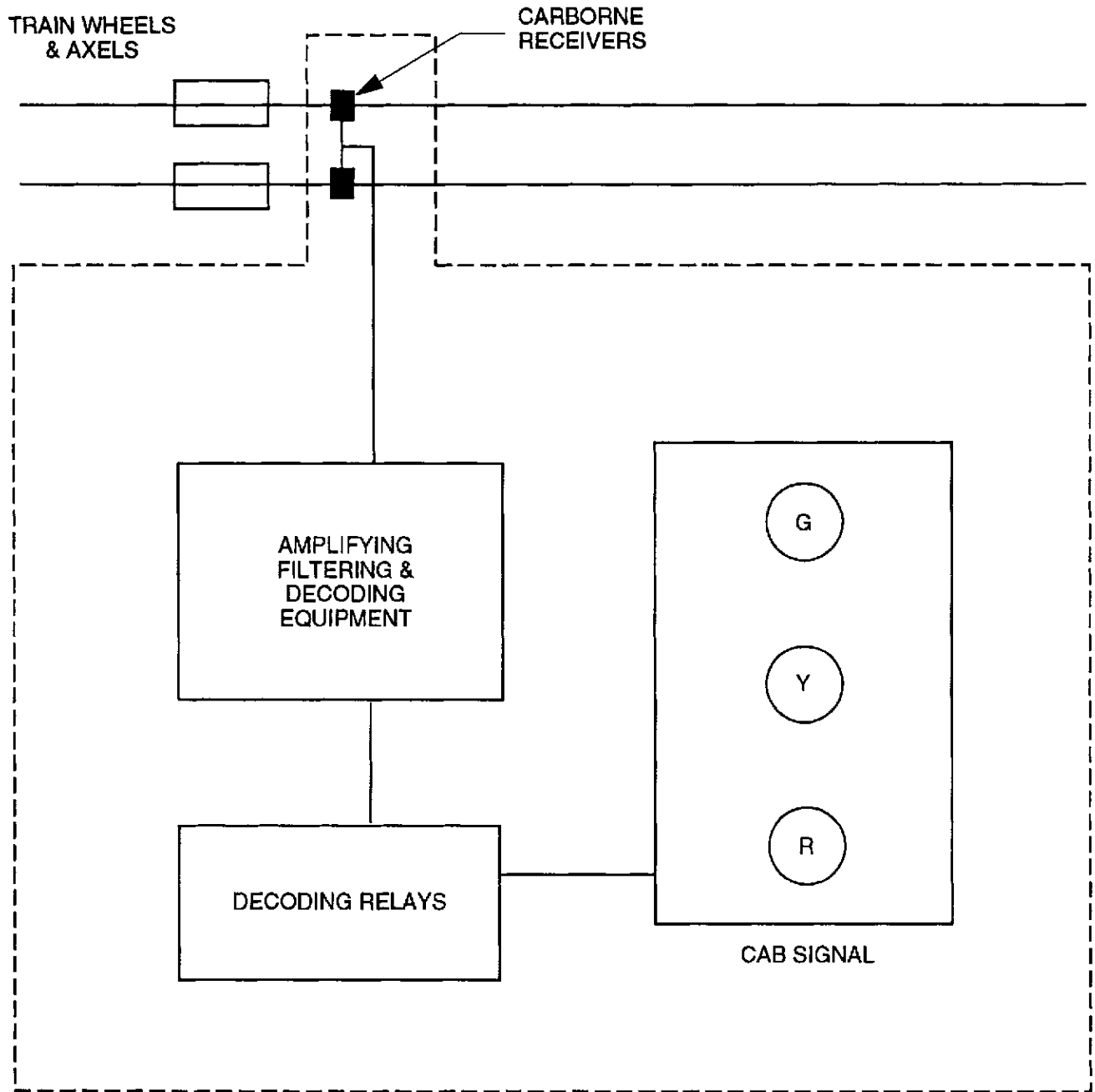

Figure 2.7. Three-Block, Three-Aspect Wayside Signal System With Some Form of ATP



HOW IT WORKS: Receiver coils, mounted on the train near the rails, receive pulse-coded track signals, which are decoded and used to pick up relays that energize the cab signal lamp indicating track conditions ahead.

Figure 2.8. Cab Signal System Schematic

For the German Transrapid maglev system, normal service propulsion and braking control is performed in the wayside power substation. Therefore, speed command transmission is to the substation, not to the train. Speed commands generated in the Decentralized Train and Guideway Control (DTGC) units are transmitted to the substation via a fiber optic link. Primary emergency braking is via wayside control using the Linear Synchronous Motor (LSM). However, backup emergency braking on the Transrapid vehicle is controlled on board by a safe speed profile extracted from ROM when movement authority is received from the wayside over the radio link.

2.4. OVERSPEED PROTECTION

1. Onboard Speed Control

The method of on-board control varies slightly from property to property because of the varying degrees of automation on different properties. However the basic principle is the same -- fail-safe comparison of the actual train speed with the maximum safe speed and fail-safe braking if an overspeed exists.

The maximum safe speed is conveyed to the train as described in Section 2.2.2. If the train is manually operated and protection is not automatic, it is the responsibility of the train operator to control speed within the maximum safe speed boundaries. This is obviously not fail-safe, and is not within current regulations for operations above 125 km/h (80 mph). (49 CFR Part 236.0 requires that trains operated at speeds of 125 km/h (80 mph) or higher be equipped with an automatic cab signal, automatic train stop, or ATC system.)

It is the lack of ATP that is currently restricting the trains on British Rail (BR) to speeds of 200 km/h (125 mph) or less. BR is currently evaluating two types of ATP systems to allow operation of its new higher speed trains. The system will be chosen, however, to accommodate all mixes of train speeds and various types of traffic: high-speed intercity, high density suburban, low density rural, and various types of freight and parcel trains. Further, the system is to provide protection even in the traditionally non-protected areas of low speed movement, such as complex station areas and shunting moves. BR has already made the decision to use an intermittent system with a beacon (or transponder) at each signal in fitted areas, and with additional in-fill beacons or loops at selected signals to maintain line capacity. They are currently evaluating two ATP systems:

- The Sel Alcatel SelCab system on the Chiltern lines. In this system, track-to-train interface is provided by a track loop (conductor 25, 50, or 300 meters long).
- The ATP system on the Great Western main line. This system uses a stainless steel loop antenna.

BR intends to use the results of these two pilot installations to provide a standard track-to-train interface specification. The data transmitted to the vehicle will include as a minimum the speed limit in the immediate section, but may also contain data about the limit in the next section. The on-board ATP equipment is responsible for supervision of train speed and enforcement of speed limits.

For high-speed properties, overspeed protection must be automatic. The train may be driven manually, but if the operator exceeds the ATP speed limit, the ATP system applies braking to bring the speed under the limit or to completely stop the train. The train speed is normally determined by a tachogenerator, which provides a voltage or current signal proportional to the wheel set speed. This may be accomplished in a fail-safe manner by using more than one tachogenerator, and determining the speed from the highest reading. Many times, an accelerometer augments the system to compensate the speed detection in the event of a wheel slip or spin. This circuit, if used, must also be proven fail-safe by the ATP system.

In traditional rail signaling, cab signals or speed commands are used to provide automatic overspeed protection. Figure 2.9 is a schematic diagram of a system such as used by the Massachusetts Bay Transportation Authority (MBTA) on their commuter rail equipment. This arrangement allows the train operator to control speed so long as it does not exceed the commanded speed shown on the cab signal unit. If the commanded speed is exceeded or if the block speed changes to a lower value because of another train ahead, the operator receives an audible warning. The operator has a fixed time (typically 10 seconds of apparatus and operator reaction time) to initiate the required braking manually. If this is done, the brakes can be released when the commanded lower speed is reached. If not, the brakes are applied automatically and irrevocably by the ATP system, and the train is brought to a full stop before the operator can resume control. Braking can be initiated anywhere within a block and instantaneously, thus permitting trains to follow one another more closely for a given block length than for a trip stop initiated stop (as discussed in Section 3.2.4).

2. Overspeed Circuits

Overspeed protection circuitry, in general, varies by authority and by equipment suppliers, and may be of analog, digital, or some combination design. Detailed circuit analyses are required for each circuit, which analyzes the possible failure modes of each component within the circuit and the result. For the circuit to be deemed fail-safe in this failure modes and effects analysis (FMEA):

- The result must lead to a more restrictive condition (lower speed) than is safe and allowable.
- Failures must be annunciated so that proper maintenance can prevent a multiple failure event.

For digital circuitry involving microprocessors, this safety analysis is more difficult to perform on the electronics themselves and in most cases, safety is achieved by dual processors, two-out-of-three processors, or by vital "watchdogs" as described in the earlier SSI discussion.

The latest generation ICE train uses LZB onboard equipment, for example, which incorporates the two-out-of-three processors philosophy. The computers are designed to function independently, having electrically separate input and output interfaces and separate power supplies. All three receive the same data and process the data according to the same program. At any one time, two of the three computers are switched through to the outputs. The third computer acts as a "hot standby" and can take over if either active computer fails. Outputs and

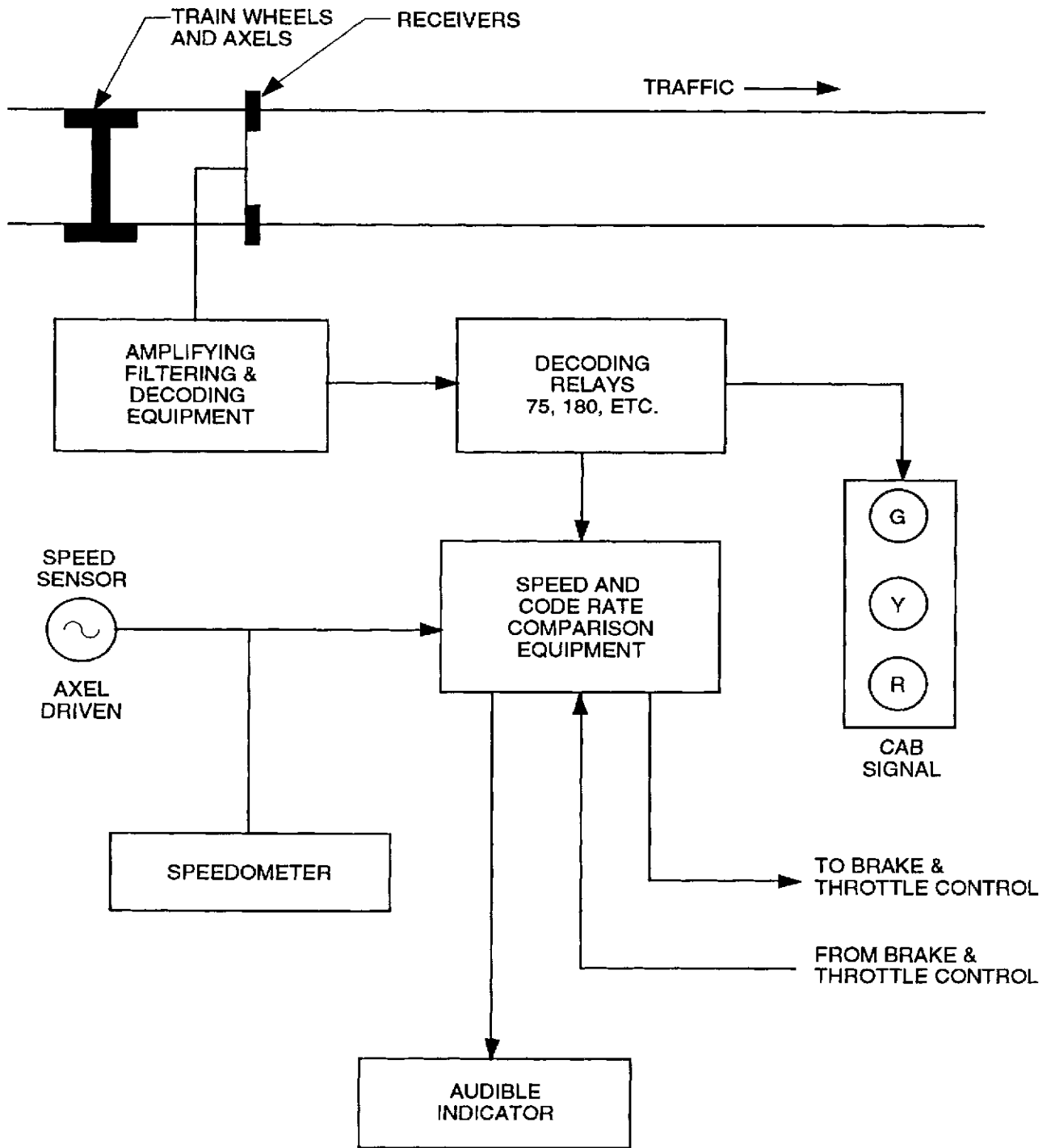

Figure 2.9. Cab Signal System with Automatic Overspeed Protection

intermediate results are interchanged amongst the computers and compared. If the result of one differs from the other two, its outputs are disabled.

Many transit properties provide automatic train operation (ATO), as well as the ATP (such as MARTA, WMATA, Baltimore, Miami, BART, etc.). The ATP functions the same way as under manual control, forcing a speed reduction when a more restrictive speed is received.

The ATO itself does not have to be fail-safe, but should be reliable. Many properties, including some relatively high-speed installations such as the Shinkansen, have been hesitant to implement ATO because of a belief the operator would be bored and not pay attention. Most of the properties with ATO have gotten around this by providing the operator with tasks at each station such as door control and dispatch. Generally, the systems operate very reliably.

Train Stops

A train stop is typically composed of a device located beside the track at a wayside signal that interfaces with a counterpart device on-board the train. The type commonly used in the United States consists of a mechanical arm that is raised or lowered in response to the track occupancy detected by the track circuit. When the arm is in the raised position, it engages a triggering device on the train and actuates (trips) the emergency brake. A train entering a block in violation of the wayside signal indication would thus be brought to a complete stop before colliding with the train in the next block regardless of what action the train operator took, or failed to take.

In addition to protecting against rear-end collisions, trip stops can also be used in conjunction with the track circuits and other signal appliances to provide automatic protection against overspeed. For this application, a timing device is added to the circuit controlling the train stop. Like track circuits and signals, the train stop is designed to operate in a fail-safe manner. The train stop is raised to the stopping position by gravity or a heavy spring and lowered by a pneumatic or electric mechanism. Thus, failure of the train stop actuating mechanism or its source of energy will result in the train stop being raised to the stop position.

Inductive and magnetic train stops are also in use. They operate in a manner similar to the operation of mechanical train stops. They are generally accepted as "more fail-safe," however, because their action is not inhibited as easily through vandalism, physical damage, and maintenance requirements. Mechanical units require additional support circuitry to ensure that their movement occurs in a proper manner, and they may require protection from ice and snow interference.

These devices are normally used primarily on properties without cab signaling. The train stop may be used in combination with onboard train protection but is not really appropriate for high-speed for two main reasons:

- Train stops allow braking initiation only at a given location, whereas conventional on-board ATP braking may be initiated anywhere.
- Train stops must be placed well ahead of the actual braking initiation point to be effective because timing over several hundred feet is normally involved.

2.5 SUMMARY OF COLLISION AVOIDANCE FEATURES

The foregoing subsections have described various essential elements of collision avoidance systems and their applicability to HSGGT. These features and their applicability are summarized in Table 2.1. The probable application of techniques for both conventional rail and maglev railroads is rated from low to high. The techniques are rated only for comparison. A low probable application rating of a method does not indicate it is less suitable, but only a comparatively less acceptable choice. The effectiveness of each method (as discussed in this volume) for collision avoidance within an HSGGT system is also rated. A further assessment of collision avoidance features of system operation is contained in Chapter 5.

2.6 SYSTEM ARCHITECTURE

Most railroad and transit operations have one central control location, but the degree of control vested in that location and distributed along the wayside varies significantly, as does the method of transmitting information between system elements. Generally, in the U.S. all vital circuitry for guaranteeing route integrity and producing accompanying signals for train movement are located along the right-of-way. The central control location communicates with large areas, typically entire rail lines, controls all functions remotely, and monitors train movement and remote system locations. Each remote location should be equipped with controls necessary to ensure that a failure of communications does not require a bypass of any vital feature of the system, while allowing a person to locally perform the functions required.

Traditionally, signals have been communicated between the central control operator to the interlocking (both vital and non-vital) and to the track by hard wire. However, as has been discussed in previous sections, more systems are coming into service using innovative ways of communication -- radio transmission, fibre optic cables, satellites, and slotted wave guides.

On small systems, centralization may reduce capital costs and even maintenance because only one major structure is needed to accommodate the major elements and most maintenance (corrective or preventive) will be in one location. An extreme example of centralized control is seen in the peplemover at Hartsfield International Airport in Atlanta, where the control room, computers, non-vital, vital interlocking, and track circuit transmitters and receivers are all housed in one area. For larger systems where an inoperative system may mean vehicles or trains stranded in a remote location, a central control failure could be a disaster from an operational standpoint unless remote facility backup operation is available.

When a system becomes large and complex, local train control permits operation to continue even if the central control location becomes inoperative. Interlockings themselves are zoned or overlapped so that some type of operation is still possible even if a single local control function goes down.

The system reliability is higher overall in this decentralized arrangement, even though maintenance personnel must be dispatched to remote locations for inspections and troubleshooting. If detection is performed at a central location, such as has been done on the ICE system, then a loss of the central control location will halt system operation regardless of the interlocking location, because detection is lost.

Table 2.1. Application and Effectiveness of Collision Avoidance Techniques for HSGGT Operation

Collision Avoidance Technique	Rail	Maglev	Effectiveness
<u>Train Detection</u>			
AC Vane	Low	None	High
TRU-II (US&S)	Low	None	High
Phase Selective	Medium	None	High
Audio Frequency	High	None	High
Frequency Shift	High	None	High
Microprocessor Logic	High	None	High
Transponder	Medium	High	High
Radio Locationing	Medium	High	Medium
Satellite Locationing	Medium	Medium	Medium
On-Board Systems	Low	High	Medium
<u>Speed Conveyance</u>			
Wayside Signals	None	None	Low
Wayside w/Cab Signals	Low	Low	Medium
Cab Signals w/o Wayside	Medium	Medium	Medium
Speed Code Transmission	High	High	High
Transponder	High	High	High
Radio Communications	High	High	High
Satellite Communications	Medium	Medium	Medium
On-Board Logic	Low	Medium	Medium
<u>Grade Crossing Handling</u>			
Total Separation	High	High	High
Protective Closure	High	None	High
Std. Barrier Closure	Medium	None	High
Warning w/Std. Gates	Low	None	Medium
Warning Lamps	None	None	None
<u>Speed Enforcement</u>			
None	None	None	None
Mechanical Train Stop	Low	None	Low
Inductive Train Stop	High	Low	Medium
Onboard Speed Control	High	Medium	High
Wayside Speed Control	None	High	High
<u>Intrusion Protection</u>			
Signs	Low	None	Low
Fences	Medium	Low	Medium
Barriers	High	High	High
Elevated Structure	High	High	High
Detection Systems	High	High	High

Decentralized (local or networked) control of vital function minimizes the reliance on communication links. This is advantageous in a large system. The split between centralized and distributed control should be addressed on a system-by-system basis to determine how best (safely, economically and reliably) these functions can be carried out.

U.S. Automated Guideway Transit (AGT) systems, often called people-movers all use centralized control facilities. In the majority of these centrally controlled systems, train routing decisions are made and executed centrally, rather than locally. Most U.S. railroads have chosen to move from local to centralized control, since the larger system overview provided enables more efficient and safer operational decision-making.

Only U.S. AGT systems enable centralized vital logic processing. Vital logic processing is much less complex on short AGT runs than on longer railroad systems. Virtually all U.S. railroad vital logic processing is now carried out at local wayside signal locations. Typically, U.S. railroad system central facilities are used for monitoring operations. Such systems can control the outlying locations if necessary, but do not have vital logic processing capability. Therefore, U.S. transit systems rely on both vital and non-vital local wayside logic processing capability.

Centralized Vital Logic - With a vital communications link, operations are stopped if any portion of the central logic facility or communications fails (without adequate backup systems). Relay logic becomes impractical due to size requirements. The backup systems required to provide operations due to failure may make this method less practical economically than other choices.

Centralized Non-Vital Logic - All vital logic being performed locally allows full system operation without loss of safety regardless of failures incurred within the central facility or communications links. Processing overhead and maintenance effects upon system operation may be significantly reduced compared to centralized vital logic. This method may include an area of local vital and non-vital logic type processing. (Port Authority Transit in Pittsburgh, PA provides this combination at a high-conflict interlocking area where three lines converge.)

Local Vital and Non-Vital Logic - This is the original method for operational controls (since 1830). This method, requiring personnel at each logic processing area (generally an interlocking), has been in the process of being phased out since 1930 in the U.S. It is generally retained where it would not be cost-effective or practical to move logic processing to a more central facility. Many such areas exist in the U.S. due to advantages of having personnel at a location where a high potential of operational conflicts exists (meeting of two different railroads) or where there are threats to operational safety (drawbridges).

Tables 2.2, 2.3, 2.4, and 2.5 summarize the train control system features of foreign high-speed systems, U.S. heavy rail and light rail transit systems, and U.S. automated guideway transit (AGT) installations. The reason U.S. transit systems are included for reference here is that while they are not high speed, they are much closer to foreign HSGGT systems in their system architecture than most U.S. conventional railroads. (The train control functions on large heavy rail and light rail transit systems are quite analogous to those required on a HSGGT system.) Implicit in these tables is the degree of local versus remote control functions for each of these systems.

Table 2-2. Train Control System Architecture: Foreign HSGGT Examples

TRACK	TRAIN COMMUNICATION	TRAIN OR LOCATION DETECTION	OVERSPEED DETECTION	INTERLOCKING LOGIC
German Transrapid 07 Emsland Test Track Single Train Only	40 GHz radio transmission link Train has 2 transmit/receive wayside stations close together to ensure train is in contact with at least 2 wayside stations	Vehicle detects its location by active interrogator on board, reading the preprogrammed location specific codes on the passive transponders then transmits location via radio link	Speed determined by time taken between passive lineside transponders. Safe speed profile stored in ROM on board, requires 2 out of 3 micro-processors	Siemens solid state processor railway interlocking units, 3 processors 2 out of 3 must agree Fibre optic link for commands to switches and radio links
French TGV	Conventional track circuits, Continuous communication.	Track circuit for wayside detection of train location. Electric cable back to interlocking.	On board tachogenerator compared against speed command. Not completely fail-safe, the operator is the ultimate back up.	Hard wired vital relays
Canada CP Rail & CN LATCS equipment being installed	Movement authority transmitted by electronic means (radio or transponder)	Pulse generator odometers. track mounted transponders and vehicle (locomotive) mounted interrogators		Traditional hard wired relays
German LZB DB	Continuous track conductors transposed every 100 meters Frequency shift, time division, multiplex coding	Vehicle reports its location (instantaneous) to wayside	Vehicle reports its speed to wayside. Wayside determines safe speed. On-board enforcement	ICE uses both relay and Solid State Interlocking (SSI)
British Railways	Wayside signals Radio electronic token block (RETB)	Traditional track circuits Axle counters Transponders (for coal train only)	Left to train operator or AWS (automatic brake if caution signal ignored). No direct speed command ATP required over 200 km/hr	Hard wired relays SSI
Japan Shinkansen	Frequency coded speed codes to vehicle via track circuit current	By track circuit	On board comparison of tachogenerator speed with cab signal speed	Vital relay logic

Table 2-3. Train Control System Architecture: U.S. Heavy Rail Transit Installations

Functions Installation	Speed Signalling	Interlocking Control	Speed Regulation	Station Stopping	Dispatch and Restart	Dwell Control	Performance Level Adjustment	Central Alarming and Monitoring	Implement Connective Strategies	Vehicle Door Control
Atlanta	BI-Directional	Automatic	Automatic	Automatic No Berthing Check	Manual With Central Guidance Signal at Ends of Line	Local Automatic Indication: Central Override Capability	Manual On Board Input	Automatic	Manual	Manual
Baltimore	BI-Directional	Automatic	Automatic	Automatic With Berthing Check	Manual with Central Guidance Signal at Ends of Line	Not Used	Not Used	Automatic	Manual	Manual
Miami	BI-Directional	Automatic	Automatic	Automatic With Berthing Check	Manual With Central Guidance Signal at Ends of Line	Not Used	Not Used	Automat	Manual	Manual
San Francisco	BI-Directional	Automatic	Automatic	Automatic With Berthing Check	Automatic	Local Automatic Control: Central Override Capably	Automatic	Automatic	Automatic	Automatic
Washington	BI-Directional	Automatic	Automatic	Automatic With Berthing Check	Automatic	Local Automatic Control: Central Override Capability	Automatic	Automatic	Automatic	Automatic
Udenwold	BI-Directional	Automatic	Automatic	Automatic No Berthing Check	Manual With Central Guidance Signal at Ends of Une	Manual no Override	None		Manual	Manual

Table 2-4. Train Control System Architecture: U.S. Light Rail Transit Installations

Functions Installation	Speed Signaling	Interlocking Control	Speed Regulation	Station Stopping	Dispatch and Restart	Door Control	Dwell Control	Performance Level Adjustment	Central Alarming and Monitoring	Implement Connective Strategies	Procurement Method
Buffalo	Automatic BI-Directional Cab Signaling on Right-of-Ways	Manual CTC	Manual	Manual	Manual	Manual	Not Used	Not Used	Automatic	Manual	Separate Contract
Cleveland	Single Direction Cab Signaling Automatic/Track Circuits	Manual CTC	Manual with Overspeed Control	Manual	Manual	Manual	Not Used	Not Used	Central Monitoring, No Alarms	Manual	Separate Contract
London Docklands	BI-Directional Automatic Wire Loops Fixed Block	Automatic	Automatic: On Board Profile Logic	Automatic	Manual with Central Guidance Signal	Manual	Automatic	Automatic	Automatic	Manual	Separate Contract
Long Beach - Los Angeles											
Pittsburgh	BI-Directional Wayside Signals Automatic Fixed Block	Manual CTC	Manual	Manual	Manual	Manual	Not Used	Not Used	Central Monitoring	Manual	Separate Contract
Sacramento	Not Used	Manual	Manual	Manual	Manual	Manual	Not Used	Not Used	Not Used	Manual	Turnkey
San Diego											

Table 2-4. Train Control System Architecture: U.S. Light Rail Transit Installations (cont.)

	Speed Signalling	Interlocking Control	Speed Regulation	Station Stopping	Dispatch and Restart	Door Control	Dwell Control	Performance Level Adjustment	Central Alarming and Monitoring Strategies	Implement Corrective	Procurement Method
San Jose	Automatic Single Directional Wayside Signals	Automatic	Manual	Manual	Manual	Manual	Not Used	Not Used	Automatic Monitoring and Alarming: No Co. Trol	Manual	Separate Contract
Toronto Scarborough	BI-Directional Automatic Wire Loops Moving Block	Automatic	Automatic	Automatic	Automatic	Manual	Not Used	Automatic	Automatic	Manual	Turnkey
Vancouver	BI-Directional Automatic Wire Loops Moving Block	Automatic	Automatic	Automatic	Automatic	Automatic	Automatic	Automatic	Automatic	Manual	Turnkey

Table 2-5. Train Control System Architecture: U.S. AGT Transit Installations

Functions Installation	Speed Sig- naling	Interlocking Control	Speed Regu- lation	Station Stopping	Dispatch and Restart	Door Control	Dwell Control	Performance Level Adjust- ment	Central Alarming and Monitoring	Implement Corrective Strategies	Procurement Method
Atlanta Airport	Automatic Single Direc- tion Sep. Sig. Rail	Automatic	Automatic	Automatic	Automatic	Automatic	Automatic	Not Used	Automatic	Manual	Turnkey
Bus Gardens Williamsburg	Automatic Single Direc- tion Sep. Sig. Rail	Automatic	Automatic	Automatic	Automatic	Automatic	Automatic	Not Used	Automatic	Manual	Turnkey
Detroit	Bi-Directional Automatic Wire Loops Moving Block	Automatic	Automatic	Automatic	Automatic	Automatic	Automatic	Automatic	Automatic	Manual	Turnkey
Jacksonville	Automatic Single Direc- tion	Automatic	Automatic	Automatic	Automatic	Automatic	Automatic	Not Used	Automatic	Manual	Turnkey
Las Vegas Airport	Shuttle Go/No Go	N/A	Automatic	Automatic	Automatic	Automatic	Automatic	Not Used	Automatic	Manual	Turnkey
Miami Airport	Shuttle Go/No Go	N/A	Automatic	Automatic	Automatic	Automatic	Automatic	Not Used	Automatic	Manual	Turnkey
Miami Down- town	Automatic Single Direc- tion Sep. Sig. Rail	Automatic	Automatic	Automatic	Automatic	Automatic	Automatic	Not Used	Automatic	Manual	Turnkey
Orlando Airport	Shuttle Go/No Go	N/A	Automatic	Automatic	Automatic	Automatic	Automatic	Not Used	Not Used	Manual	Turnkey

Table 2-5. Train Control System Architecture: U.S. AGT Transit Installations (cont.)

Functions Installation	Speed Signalling	Interlocking Control	Speed Regulation	Station Stopping	Dispatch and Restart	Door Control	Dwell Control	Performance Level Adjustment	Central Alarming and Monitoring	Implement Corrective Strategies	Procurement Method
Sea Tac Airport	Automatic Single Direction Sep. Sig. Rail	Automatic	Automatic	Automatic	Automatic	Automatic	Automatic	Not Used	Automatic	Manual	Turnkey
Tampa Airport	Shuttle Go/No Go	N/A	Automatic	Automatic	Automatic	Automatic	Automatic	Not Used	Automatic	Manual	Turnkey

3. VEHICLE, GUIDEWAY AND WAYSIDE DESIGN TECHNIQUES FOR COLLISION AVOIDANCE

3.1 INTRODUCTION

The HSGGT vehicle, guideway, and adjacent right-of-way should be designed to prevent or minimize four types of events:

- Collision with animate objects (i.e., trespassers, birds, projectiles, livestock, motor vehicles, system personnel)
- Collision with inanimate objects (i.e., debris)
- Train overrunning the end of the guideway
- Collision with train of different type on shared or adjacent right-of-way

The ideal guideway for a high-speed system is one that is used solely for this system, located on dedicated right-of-way.

Some older systems operate on shared guideway and/or shared right-of-way with freight and/or commuter railroads, having followed an "incremental improvement" approach. A set of collision avoidance problems has arisen in these situations because of varying safety requirements for these different systems. In this chapter, problems associated with both dedicated and shared rights-of-way will be addressed.

A dedicated right-of-way should be grade-separated and consist of the following elements:

- At-grade with fences or barriers
- Tunnels
- Elevated structure
- Overpasses
- Underpasses.

Use of these guideway elements depends upon a system's vertical alignment, aesthetics, environmental concerns, economics and other special considerations (i.e., noise, visual impacts, community concerns, etc.)

3.2 DESIGN TECHNIQUES FOR COLLISION AVOIDANCE SYSTEMS

3.2.1 Right-of-way Design

The U.S. practice has not required right-of-way fencing on railroads, except in localized areas where special protection is necessary. The use of elevated structure, tunnels, overpasses or underpasses accomplishes the same objective as full length fencing. The new high-speed lines in Japan and France are completely fenced, and the law in Great Britain requires a fully fenced railroad right-of-way.

1. Fencing and Barriers

Acceptable forms of pedestrian barrier include fences, walls, and elevation differences of appropriate magnitude, designed and operated with the following guidelines in mind:

- *Height.* APTA guidelines recommend that the total height of the barrier should be a minimum of 8 feet, and it should include a 1 foot high physical deterrent or obstruction such as barbed wire, to discourage entry of unauthorized personnel.
- *Safety Railings.* Where elevation differences alone constitute a sufficient pedestrian or vehicular barrier, it may be desirable to provide safety railings.
- *Bird Protection.* Fencing and barriers as high as the vehicle themselves may be necessary in some areas to prevent collisions with birds. Strategic positioning of hawk and owl "scarecrows" could also be used to help prevent birds from colliding with vehicles.
- *Climatic Conditions.* Special conditions such as drifting snow should be evaluated when designing these fences or barriers.
- *Sound.* Barriers could also serve as sound attenuation walls in areas of high noise sensitivity.
- *Overpasses and Walkways.* Where the right-of-way is crossed by a pedestrian walkway or motor vehicle overpass, screening may be used to protect the guideway, high-speed vehicles, passengers, and personnel from debris and other objects falling or being thrown from those overpasses and walkways. On TGV Atlantique overpasses, for example, the catenary is protected by wires that sense objects that pass through the overpass guardrails and drop onto the wire and then down to the track. These sensors, connected to the signal system, transmit stop commands for that location when a breach is sensed.

A thorough inspection of the high-speed right-of-way prior to daily operations is another measure that can be taken to ensure the integrity and safety of the system. Any obstruction that would pose a safety hazard should be identified and removed prior to the day's operation. The SNCF undertakes a physical inspection of its high-speed lines prior to revenue service each day.

2. Motor Vehicle Barriers

In locations where there are adjacent parallel highways or crossings (bridges), motor vehicle barriers may be desirable. Motor vehicle barriers include highway guardrails, barrier curbs, structural walls, or earth embankments. In each case, where vehicular access to areas adjacent to the system right-of-way is possible, individual circumstances should be evaluated, including the possibility of accidental entry by runaway motor vehicles.

3. Animal Barriers

Some means of preventing animals from gaining access onto the dedicated right-of-way should be investigated. Animal movement and migration patterns and their possible conflicts with the high-speed system should be identified. The TGV in France has employed wild animal bridges, frog

tubes and a bridge along every kilometer of right-of-way as a creative means of mitigating this type of problem.

4. Signage

Acceptable warning and information signs should also be posted at determined intervals throughout the system, within easy view of pedestrian and vehicular traffic. Warning and information signs should conform to applicable jurisdictional requirements.

5. Intrusion Detection Devices

Historically, the only guideway intrusions monitored have been rock slides and snow slides. Slide detectors are provided on many systems to ensure that foreseeable local conditions have not created an unsafe condition along the route. These detectors consist of fragile wire fences and fail-safe circuitry. Any breach of the fence system forces signals along that route to their most restrictive aspect. Rock slide detectors are used throughout the U.S. where such conditions exist, and on the TGV. Snow slide detectors are in use on Japan's Shinkansen system. The TGV uses similar fail-safe detection of vehicle encroachment.

These devices could take the form of:

- *Closed circuit television (CCTV)*
- *Movement, light, or sound based intrusion alarm devices*
- *Systems that send signals to a central control facility or onboard vehicle monitor*
- *Intrusion alarms, designed to minimize the probability of incorrect reaction to the signals by operating personnel and the public.*

CCTVs or intrusion alarms can be located on doors, gates, and other possible right-of-way access points. They can be monitored by onboard operations, local station or central control personnel. Types of intrusion detection devices now in use on conventional and high-speed systems include:

- *High wind detectors.* Used with double stack container trains and multi-level automobile carriers on the Union Pacific Railroad in Wyoming, where high winds have caused incidents. Also used on the Shinkansen system.
- *Earthquake detection system.* Used on the Shinkansen system to detect seismic tremors that could damage tracks and structures. Also used on new U.S. transit systems in areas of high probability of earthquakes.
- *Vehicle detection system.* Used to detect the presence of vehicles encroaching onto a high-speed right-of-way. The TGV has installed these systems at highway overpasses and at places where major highways parallel the TGV corridor. Some mass transit systems (e.g., Atlanta and Washington) have installed or are developing similar intrusion detection systems in response to concerns about encroachments caused by accidents on parallel freight railroads.

Non-Vital Detection

This kind of detection provides an indication to the central control area and/or train operator that intrusion has occurred. Non-vital detection is used only where the intrusion is probably not threatening to train movement or the detection system cannot be made sufficiently reliable to be included in a "vital" system.

Vital Detection

These types of devices detect threats to train safety and can be linked to the train control system. A good example is the Swedish Railways' grade crossing protection circuits. In response to a warning, the system can trigger speed restrictions on the trackage in question until a proper inspection of the right-of-way can be completed.

Vital intrusion detection can be provided that will interface with vehicle systems and immediately begin brake application. This type of system can be further enhanced to interface with other systems to determine immediately if a collision is imminent.

If the train is so equipped, the system can provide additional braking forces ("ultimate braking") using unconventional techniques such as aerodynamic braking to minimize impact. This level of detection and braking would require logic processing not previously used on any railroad, but is a consideration for future minimization techniques.

Traditional vital intrusion detection (i.e., rock slide detectors) interfaces with the speed conveyance system to stop a train short of the intrusion, and can be installed where significant threats to the HSGGT exists.

6. Warning Devices

This section deals with devices intended to warn people or animals on or near the guideway of the approaching HSGGT.

HSGGT vehicles could contain the onboard visual and audio elements that could warn both people and animals and are described below.

Devices Used for People

- *Visual Signals.* Constant visual signals such as flashing lights, headlights, and marker lights (taillights)
- *Audio Signals.* Constant audio signals that may be advisable for high-speed trains, especially if not on dedicated right-of-way
- *Momentary event audio signals.* Bells and horns, etc.

Devices Used for Animals

- *Visual Signals.* Special visual signals for animals that could include "scarecrow" symbols such as a hawk or owl
- *Audio Signals.* Special high-frequency audio signals for animals, inaudible to humans

3.2.2 Guideway Design

Two major elements in guideway design are discussed in this section -- track switch protection and end-of-guideway measures.

1. Track Switch Protection

Generally, collision occurrences fall into two areas: maintenance items, and accidental or intentional events.

Maintenance Items

This area includes:

- *Switch point or switch frog chipping or breaking.* This allows a wheel flange to climb above the rail, causing derailment.
- *Rail vehicle wheel flange damage.* This may produce a tendency for the wheel to climb outside of the rail, causing derailment.
- *Inadequate structural support of the rail.* This aggravates the potential of the previous two items.
- *Failure to test/maintain vital signal systems.* These are systems that provide route integrity of moves over the switch, such as point detector and lock rod adjustments, and supporting circuitry, as is mandated under current FRA regulations.
- *Failure to attempt to provide all available means to prevent vandalism.* In the U.S., many railroads are replacing old style switch locks, because keys are readily available as "collector items," in favor of high security forged locks. Many switch units still use a casting, however, upon which high security padlocks are placed.

Accidental or Intentional Incidents

This area includes:

- *A vandal accessing a hand throw lever by breaking locking devices.* This cannot be entirely prevented, but, all foreseeable opportunity for access to a hand throw rod of a switch machine can be eliminated.

- *A train dragging equipment through a switch layout and damaging equipment* in a manner undetectable by normal safety circuits, but able to derail a train. Dragging equipment detectors are placed at strategic intervals today in the U.S. to detect such damage.

Current FRA regulations require electrically locked devices on manually operated switch machines in high-speed track. A padlock provides the first level of security, with a signal circuit ensuring that conditions are safe to allow switch movement prior to electrically releasing the hand throw lever. In the case of dual-control electrically operated switch machines, generally two padlocks are required to be released in order to release the safety systems and move the switch machine.

All switch machines interface with the signal system governing train moves, so any signal system whereby the operator of the train is constantly updated on conditions ahead affords the highest level of security from vandalism.

2. End of Guideway Measures

Encroachment prevention measures become extremely important at end-of-guideway areas. Preventing vehicles from overrunning the guideway can be accomplished in one of three ways:

- *Extension of guideway without power.* The guideway section is extended beyond the power distribution system/vehicle interface without power so that a train traveling at maximum speed (including grade and wind) could not reach the end of the guideway. For the high-speed trains, this could require a long section of guideway.
- *ATP or cab signal speed controls.* ATP or Cab Signal Speed Controls can be utilized to limit speed near the ends of the guideway. This method does not assist in stopping a train that has incurred brake faults and it should only be used with complementary means.
- *Retarders.* These devices, normally used in freight classification yards, reduce speed by "squeezing" the wheels of the vehicle. The present configuration of retarders would be applicable only to steel-wheel-on-steel rail systems, but it may be possible to develop a similar device for maglev systems.

If a high-speed train has already overrun the end of the guideway, it must be prevented from intruding into other areas. This could be accomplished by:

- *Energy absorbing barriers.* Barriers such as sand, pea gravel, or water that would absorb the energy of a moving train during collision sufficiently to stop the train. These types of devices are conventionally used in mountainous terrain to ensure the stop of highway vehicles with brake failures.
- *End-of-track buffers.* End-of-track buffers use hydraulic rams, springs and friction components to absorb impacts of trains. Current end-of-track buffers would require redesign to meet the impact forces possible from high-speed trains. As a practical matter end-of-track buffers can only be designed for relatively slow speed impacts.

3.2.3 Grade Crossing Design

As addressed in the Volume 1, rail-motor vehicle collisions at grade crossings are a significant cause of accidents in all countries. The consequences, always serious for the road vehicle, can also be serious for the train.

The possible responses to these problems include:

- *Grade separation where at all possible.* Separation structures (i.e., underpasses or overpasses) can normally be justified on the basis of enhanced system safety and security alone, but they must also be evaluated as to their impact on system costs.
- *Enhancement of grade crossing warning and protection devices.* Examples are physical barriers, vehicle detection systems, and warning devices.
- *Enhancement of warning and protection controls.* This is done especially to optimize the time between the start of the warning cycle and the passage of the train.
- *Addition of a central barrier in the highway.* This is to discourage weaving through gates.

1. High Speed Introduces New Factors

Highway grade crossings are not typically "intrusions," and use of only a warning device is now standard, with highway access to the guideway rarely closed. While cars have always been more vulnerable than trains in collisions at grade crossings, as speeds increase to present and anticipated levels, several factors become more significant:

- Gates may be down as much as three minutes in advance of a train reaching the crossing to achieve train safety, encouraging more motorists to make a judgment of whether to cross the guideway, in the belief that the devices have malfunctioned. Train safety requires the gates or barrier system to be fully in place, with any vehicle detection systems checked, prior to allowing a signaled route through the crossing. Allowing one minute for barrier closure, at 240 km/h (150 mph), a train must be more than one block length plus 73 seconds distant (see braking Table 4.2).
- The motorist will most likely not see the train approaching at all because it advances upon the crossing at up to 100 meters per second (300 feet per second) when operating at 330 km/h (200 mph). While the automobile is taking 6 seconds or more to clear the guideway area, the "invisible" train covers up to 600 meters.

Given these factors, grade crossings in an HSGGT system should include vital intrusion detection to ensure to all practical levels that no person, animal, or object is trapped within the necessary barrier type system.

Maximum speeds over grade crossings have generally been restricted in practice if not by regulation. Some European railways (e.g., France's ANF Turbo, Germany's Ausbaustrecken, Great Britain's High-Speed Train, and Sweden's X2000) permit operations at 200 km/h (125 mph) over grade crossings on existing track. They do so because eliminating all such crossings

in the short term is considered economically impractical and operating practices are judged to be acceptable. Canada has a legal maximum speed of 150 km/h (95 mph) over grade crossings.

In the United Kingdom and the United States, the typical practice has been to eliminate grade crossings where speeds exceed 145 km/h (90 mph). Presently, there are only about 15 grade crossings in the United States where the railroad speed is greater than 145 km/h (90 mph). All grade crossings on the Northeast Corridor where speeds exceed 160 km/h (100 mph) have been eliminated over the past decade. As technologies have improved, the possibility of grade crossings in an HSGGT system has been proposed at speeds as high as 240 km/h (150 mph) on the Central Gulf route between Chicago and St. Louis.

2. Design Considerations

If grade crossings must be used, grade crossing devices should interface with the signaling system in such a manner that signals will be controlled, in part, by conditions monitored at the grade crossings.

Highway grade crossings in high-speed track require in-depth analysis of each location to determine feasibility of the options available under current state-of-the-art technologies. European railways have the most experience with current technologies in this area. The current code of the Union Internationale de Chemin de Fer (UIC) states that no such grade crossings should be tolerated at speeds in excess of 200 km/h (125 mph).

Depending upon specific site and operational conditions, the practicality of a crossing at grade becomes a key issue. A discussion of grade crossing alternatives is presented below.

Vital Grade Crossing -- Warning vs. Protection

Crossing warning systems may be impractical for HSGGT use because they create a temptation for motorists to make judgments and produce a high risk of collision. There are no statistics of "proper judgement" of motorist with regard to ignoring a warning device. It should be noted, however, that most motorists are better able to judge an automobile's speed than a train's, and 8 percent of all decisions to pass an automobile are wrong. The logical assumption follows that the percentage of "wrong decisions" when a motorist chooses to judge and ignore a crossing warning device is considerably higher.

As train speed is increased, the requirements change significantly. A motorist, deciding that conventional crossing gates have malfunctioned and choosing to drive around the warning, will require at least 6 seconds or more to proceed around the gate. During this time, the train that was previously perceived by the motorist as distant has covered 335 m (1100 ft) at 240 km/h (150 mph). Therefore, rather than conventional warning devices which allow potentially fatal decisions on the part of motorists, grade crossing protection is desirable in very high-speed areas so that collisions can be prevented with certainty.

Another option is signaling through the high-speed crossing areas in a manner similar to the restrictive state for highway moves, and no highway vehicle is present. This option is analogous to the prevention of conflicting movements at an interlocking. It ensures a greater margin of safety than current practice, at the expense of substantially longer stoppage of highway traffic.

The potential of decreasing the negative impact of such additional highway closure may be achieved, depending upon highway use, with highway signals at significant intersections in advance of grade crossings. Such integration of rail and highway traffic controls is becoming feasible with the current recognition signaling standards of interlockings. These standards require that no signal indication less restrictive than the most restrictive possible be allowed until protection is known to have operated to its and development of intelligent vehicle highway systems.

The most effective protection is afforded by full grade separation, which provides the highest level of safety along with the easiest acceptance by the public at large. On the other hand, full grade separation also has the potential for environmental disruption, creates additional cost, and often is not a viable alternative due to other local constraints.

Grade separation will be necessary, however, for certain key highway routes, both for the convenience of the public and for emergency vehicle routing. While the Swedish experience is an example of coexistence of high-speed rail and grade crossings, it should be noted that the Swedish State Railways is eliminating two-thirds of the crossings on its principal high-speed route.

Barrier Type Systems

Effective vital protection can be accomplished by way of barrier-type gates that prohibit highway traffic entirely when activated. Such a fail-safe system demands a very high level of fault tolerance, as any single failure may prevent highway vehicle passage and may require alternative operation possibilities for emergency vehicles.

The fenced right-of-way combined with a barrier system creates an area secured for train movement. Conversely, it can trap livestock if the barrier is not designed to insure that access to the track right-of-way is prohibited to livestock when it is in position to allow highway traffic. Animal entry to right-of-way is inhibited when cattle-guard surfaces are used in conjunction with and adjacent to the dual position barrier.

Any vital grade crossing protection system should include a level of certainty that no vehicle is within the limits of the crossing. Such detection can be provided with sweeping type devices, optical sensing devices, or conventional tuned loop vehicle detectors.

Interaction of Crossing Protection and Signals

Conventional grade crossing devices usually operate independently of the signal system. A protective system, however, must be fully designed under accepted closed circuit principles to

interface with the signal system, and to place the signals at their most restrictive if the devices do not detect safe train movement. This requirement equates to standard interlocking design principles, not conventional grade crossing warning systems.

Initial operation of such protective devices is required sufficiently in advance of a train to allow all devices to be checked in their fully protective state, with the time allowances for emergency braking distance, equipment and train operator response times. Depending upon the rail vehicles and equipment in use, the time required to begin the protection sequence will range from 75 seconds to 105 seconds before the train will reach the highway, for 240 km/h (150 mph) train speeds. Any failure of any vital component of the crossing devices or in their detection of a highway vehicle, will result in the approaching train being stopped short of reaching the crossing.

When two trains approach the crossing on separate tracks, the protection devices will not clear to allow highway traffic within a predetermined time prior to the activation of the crossing apparatus by the second train. This condition has the potential of stopping all highway traffic for 230 seconds or more (for trains traveling at 240 km/h).

In Sweden, grade crossing protection systems are enhanced with a vehicle detection system that consists of an automated induction loop that is linked to the X2000's automatic train control (ATC) system. Any vehicle "sensed" on the crossing will send a stop command to the ATC system, automatically stopping the train.

3.2.4 Vehicle Systems

This section addresses vehicle braking systems and their interface with the signal system to prevent collision. Action enforcement and the vehicle monitoring systems are discussed separately.

1. Train Braking System

The braking systems in use have undergone technological advancements quite regularly since 1830. The inclusion of braking enforcement is considered a necessity in an HSGGT system, with functions currently ranging from monitoring failure to reacting properly to a stop signal, to speed monitoring. When ATP is in use, the train receives ATP signals from a central computer or from a wayside-based system that are processed by the train ATP system to initiate fail-safe braking when speed reduction is required (including a full stop).

Friction brakes are normally considered the fail-safe element of train braking, but in some high-speed applications, efforts have been made to use the dynamic, or electric brake as well as an eddy current brake, as part of the fail-safe portion to increase the minimum guaranteed brake rate.

Vehicle braking systems may be electric, friction or aerodynamic. These types of braking systems are often used in combination to form redundant systems. Typically, the dynamic (electric) brake is the primary system, with a friction braking system as the backup. In general, the total system comprises a parking brake, a service brake, and an emergency brake. Control is generally electric.

Electric Brakes

Electric braking, typically a part of the propulsion system, utilizes the traction motor(s) to slow the vehicle. Motors can be rotating or linear induction of either AC or DC drive. The dynamic brake is an electrical arrangement used to change some of the mechanical power developed by the momentum or downhill force of the moving train into electrical power, creating a braking force. The dynamic braking current can be regenerated back into the power distribution system or dissipated through resistor grids. For rotating motors, traction motor armatures (being geared to the axles) rotate whenever the train is moving. During dynamic braking the motors become electrical generators. Linear induction motors use eddy currents to excite the stator fields which in this case are mounted on the guideway.

This type of braking system must be supplemented by other braking systems, and may not be considered as practical for emergency braking purposes in an HSGGT system, because adequate safe braking must still be provided during total power failure.

Friction Braking

Friction braking is divided into two categories:

- Rotating surface braking includes shoe to steel wheel, and disc brakes.
- Hydrostatic and translational surface friction braking include track (electromagnetic) and skid pads or sliders.

The control system for most friction brakes is an actuation release design. In an actuation release system, the normal state of the system is for the brakes to be applied so the brakes must be released to move a car or train. With this design, system failures will result in a brake application. Typically, most systems have had pneumatic controls with pneumatic brake actuators, frequently "overlaid" with a redundant electric control system that serves as the primary control system, with the pneumatic control system serving as a backup.

Most high-speed vehicles have disc brakes for the friction braking system. The discs are mounted on hubs which in turn are mounted on the wheel/axle assembly. The disc brake actuator is mounted on the vehicle truck. Pneumatic or hydraulic pressure is used to regulate the amount of retarding force delivered to the disc and wheel/axle assembly to reduce train velocity. The system works in a similar fashion to the front wheel braking system on most automobiles. See Figure 3.1. Here it can be seen that some disc brake systems have four units on one axle.

Some high-speed vehicles also employ tread brake units. These brake actuators apply force directly to the wheel tread. They are also mounted on the vehicle truck. The amount of braking achievable via tread braking is less than that for disc braking, which is why most high-speed vehicles principally employ disc brakes. Typically, tread brakes are used to supplement one set of disc brakes, where another full set of discs is not required. This practice allows for easier maintenance, because the tread brake units can be easily replaced on the vehicle, and tread brakes have the additional advantage of improving wheel/rail electrical contact which improves operation

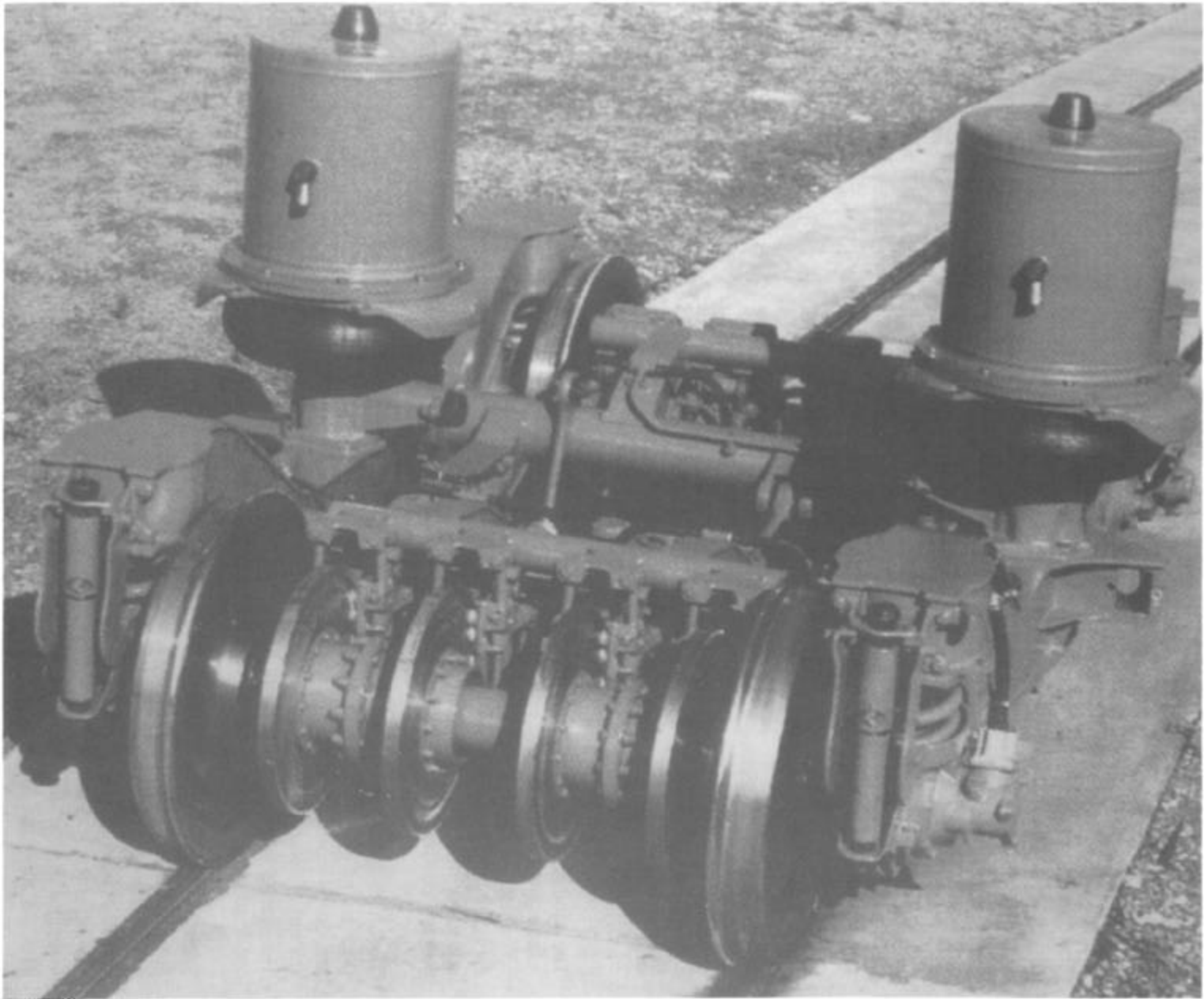

Figure 3.1. View of 4 Disc Brakes on a Wheel/Axle Assembly

of track circuits used for vehicle detection. Replacement of discs and disc brake actuators, in most cases, requires that the entire truck be removed from the car.

The TGV Southeast Line trains use traditional cast iron ventilated brake discs that have operated quite satisfactorily from a mechanical viewpoint. However, this ventilated disk design causes significant energy losses - each disc absorbing about 3 kW of power when running at 270 km/h due to the pumping of air around the ventilating passages. In seeking to improve the energy efficiency of the TGV, French engineers were able to reduce this pumping action through a different disc design.

The innovative disc design eventually developed for the TGV-Atlantique line vehicles employs a forged solid steel brake disc which causes negligible pumping losses. It also compensates for its loss of cooling capability by being able to withstand higher temperatures than the cast iron disc design. The use of steel also allows higher localized stress in the braking surfaces, permitting a higher rate of energy input to the disc faces.

Aerodynamic Braking

Aerodynamic braking could include systems typically used on other high-speed vehicles such as aircraft that induce drag by means of changing aerodynamics, thus slowing the vehicle. Air brakes have been used on aircraft that deploy large flat surfaces to decrease speed quickly by means of inducing high air drag forces. Assorted means of air flaps and spoilers are used to alter aerodynamics on aircraft and increase drag. Parachutes are used to increase braking ability on drag racing cars and can be employed to significantly shorten braking distance of any high-speed vehicle. Thrust reversers, acting similarly to those employed on jet engines and jet type boat motors can be used to produce significant braking force. The effectiveness of all aerodynamic braking systems will be relative to vehicle speed at the time deployed, which places additional risks upon the use of these systems.

Deployment of a parachute can create significant decelerations upon passengers, requiring passengers to be seated in reverse facing seats or to be restrained prior to deployment to preclude personal injury. The practicality of any parachute system is in part predicated by the structures surrounding the guideway area. As braking rate is a function of speed at time of deployment, it is possible this method could produce decelerations beyond those acceptable to some passenger's physical limits, introducing potentially damaging, or fatal results without collision. Use of parachutes cannot be discounted entirely, though probable risk must be evaluated by vital systems prior to deployment to avoid collision.

Air braking and reverse thrusting systems are practical for use in an HSGGT system because they can be deployed at incremental levels based upon required need (threat of collision) and train speed. Such systems would require advanced ATP techniques and interfacing with other systems. They should be considered although no systems are in use today that can be directly applied to HSGGT systems.

2. Train Health Monitoring

The train health monitoring system verifies the integrity of safety critical systems (including braking, antennas or pickup shoes, speed, and acceleration and deceleration monitoring) and acknowledges receiving signals from ATP. In the past, monitoring of axle bearings has been performed by wayside systems but onboard monitoring may be practical in an HSGGT system. These systems often have their own self verification testing system, especially in recent technology applications where microprocessor control of most systems is now prevalent.

Onboard monitoring of all safety critical factors, the failure of which could predictably (and probably) result in a collision, should be provided in an HSGGT system.

3.3 ENFORCEMENT AND HUMAN ACTION

Responsible human observation, decision, action, and reaction comprised the only collision avoidance system used prior to mechanical, electrical, and electronic systems. Newer technologies have complemented human action, enforced it, and totally removed the human action from many aspects of collision avoidance. The level of human action required in an HSGGT system will be decided based upon the acceptable levels of responsibility every individual must assume.

Action of maintenance personnel is a most important consideration when ascertaining qualifications of individuals that have the power to inhibit, repair, or test all vital sub-systems of the collision avoidance system. Issues of concern in this area include:

- Operators following system directives
- Enforcement should they fail to act in a predetermined manner
- The inevitable actions required by all operating and maintenance personnel when failures of any significant portion of the collision avoidance system occur, and areas of protection must be bypassed

This area includes all systems that are designed to ensure that a train operator engineer reacts in a predetermined manner to any direction of the system. Current technologies provide the ability to convert these systems from enforcement to automatic operation, thus reducing the human role to standby and intervention. Typical systems in use today, referred to as ATP systems, ensure that the engineer brakes when required or does not proceed faster than authorized by the signal system. The brake may be retrievable or irrevocable, and it may be at a normal service braking rate or at a higher emergency rate.

In the following sections, the three basic elements of train control and signaling will be addressed in more detail. Normally, enforcement systems do not remove an individual from the process, but enforce a safety factor if the person fails to act in a predetermined manner that will prevent an unsafe condition.

The speed limits and route authorities must be enforced by some type of train stopping device for the overall system to be effective in preventing collisions. This can be done in several different ways, but the most common location for this protection is on the train (or vehicle) itself. After the safe speed signal has been received by the train, either the operator or the automatic controller is responsible for bringing the train speed within the new limit. The onboard methods for performing this function are discussed below. The function of overspeed protection, discussed in the following sections, may also be performed by wayside equipment.

3.4 VEHICLE MALFUNCTION SAFETY SYSTEMS

3.4.1 Wayside

Wayside safety systems monitor train conditions and transmit alarms to a local or central control facility if they detect a vehicle malfunction. These systems include hot box detectors, hot wheel detectors, derailment or dragging equipment detectors and clearance detectors. While these wayside systems have been used well in the past, they should be supplemented with onboard monitoring. As an example, undercarriages have caused derailments in the past and cannot be monitored by wayside safety systems. Onboard systems can constantly monitor such items as the undercarriage, axle bearings, and brakes.

1. Hot Box Detectors

Hot box detectors are wayside heat sensing devices that detect hot axle bearings. An overheating axle bearing can quickly fail and cause an axle failure leading to a derailment. Hot box detectors measure the infrared radiation emitted from bearings as they pass and compare them to adjacent bearings in the same train. If a high reading is noted, the train is signalled by the detector system or a remote station. Upon discovery of a possible bearing problem, the train would then be stopped and inspected by the crew. A remote operator may read a "tape" of the readings and give a location of the suspected hot box, or the train crew may be required to inspect every bearing.

Newer systems incorporate two wayside sensors that compare readings for each axle, thereby eliminating errors. Hot box detectors are employed on the TGV every 40 to 50 km (25 to 31 miles) and measure bearing temperature history, rate of rise, and absolute temperature. Output from these detectors is transmitted directly to the central dispatching center for analysis.

2. Hot Wheel Detectors

These systems are very similar to hot box detectors but they differ from them in that the heat sensor is aimed at the wheel tread and not the axle bearing. This system detects sticking tread brakes. If a sticking brake is detected, the train crew would be required to stop the train and release the brake(s) on that vehicle.

3. Derailment/Dragging Equipment Detectors

Derailment or dragging equipment detectors are used at bridges, tunnels, and intermediate points to verify that vehicles are still on the rail and that equipment is still intact.

4. Critical Clearance Detectors

Critical clearance detectors are often used before major fixed facilities such as bridges or tunnel entrances to verify that equipment or debris is not outside of the clearance envelope for the fixed facility just ahead. These are typically used on freight railroads, and their usefulness on an HSGGT system should be considered.

3.4.2 Onboard Vehicle

Many of the same functions described in the previous section can also be performed more effectively on board the vehicle. In addition, other critical mechanical and electrical functions can be tested or sensed. As microprocessor and communications technology is advanced, the quantity of information available also increases. The onboard detectors and diagnostic routines can be used to:

- Alert the operator.
- Initiate speed reduction or performance reduction.
- Signal a central location of needed maintenance or other special operating procedures.

In the United States, the Burlington Northern Railroad is testing a thermal sensor bolt called "SMARTBOLT" that is to be installed in journal bearings. The "SMARTBOLT" system consists of a thermo-mechanical sensor with an actuator. When a preset alarm temperature is reached, the sensor extends a piston that employs an antenna and activates the electronics. The antenna transmits an alarm signal to a receiver in the locomotive and acts as a visual indicator during subsequent inspection.

3.5 HUMAN ROLE IN SUPPORT OF COLLISION AVOIDANCE

As discussed in the Volume 1 Report, human error is one of the most significant causes of train accidents. Therefore, establishing appropriate operating rules and practices will be very important, even if a sophisticated ATC system is used to supervise train operator actions.

Train operator errors include:

- Failure to obey signal indication, operating rules or instructions
- Operating at speeds exceeding those permitted for the location or type of train

HSGGT systems need to develop and maintain a comprehensive set of operating rules of conduct and instructions for specific locations and types of equipment. Typical subjects addressed include brake test, emergency, and dispatching procedures; crew size and shift lengths.

Good operating procedures can reduce risk of collisions due to train crew error or signal dispatching. Also, in case of an emergency, train crews will be ready to respond appropriately to minimize casualties.

Human error by signal maintenance personnel is the most unpredictable failure that can probably occur in a well designed HSGGT system. Routine maintenance and testing procedures bypass safety functions provided by the signal system sub-systems. The methods for performing such functions and the qualifications required to do so should be carefully planned and regulated to keep this human error factor at acceptable levels.

Ensuring that operating staff are properly qualified and trained is an important factor in the prevention of such accidents. This requirement is always present, even on largely automated systems because there will always be occasions when manual control of train movements is required, if only when there have been malfunctions of the automated system. The HSGGT systems should ensure that the occasional manual override of safety systems due to system problems is reduced by use of fault tolerant fail-safe systems wherever possible. The train control and signals systems should be susceptible to an attenuation of responsibility with reduced train speeds, before requiring a full manual override of both systems.

Personnel training and qualifications are primarily the internal responsibility of individual railways. Consequently, these practices vary considerably. For example:

- In France, the SNCF regards the TGV as simply a new piece of equipment, and training is brief. However, the SNCF has long experience of high-speed operations on conventional lines and all TGV operators are senior employees.
- In Japan, the Shinkansen is regarded as a separate system substantially different from the rest of the rail system and requiring special training.

At the same time, an educational program designed for the public who live and work around high-speed systems could provide important information about HSGGT operation and warn of dangers, and would be an effective means of accident prevention. Consequently, a comprehensive educational program would be an important part of HSGGT implementation in the United States.

3.5.1 Maintenance and Testing Practices

Failure to evaluate subsystems' integrity on a proper regular basis in a defined manner can result in failures that allow speeds greater than would be otherwise allowed by the signal system. This area is closely tied to training and qualifications.

Most Authorities have strict guidelines that serve to qualify train operating personnel in order to limit possible collisions in this area. However, very few Authorities have any guidelines for qualifying personnel responsible for installing, altering, and testing vital subsystems of a collision avoidance system. Many collisions or false proceeds have occurred due to actions of an

improperly qualified signal system maintenance person. (A false proceed is an unsafe condition whereby a signal or speed command presents a less restrictive speed or indication than should be safely displayed.)

3.5.2 Human Action Limitations

People make mistakes. Hindsight usually reflects why an error in judgment or action occurred, but unintentional mistakes can, and do, result in failure to stop or failure to obey a speed limit, and such mistakes may result in a collision. Introduction of higher speeds requires faster recognition of speed conveyance signals, because wayside signals are becoming impractical due to physical limits of visibility.

Lack of appropriate guidance for a given situation in the operating rules and instructions is a rare cause, but is possible, most probably in an emergency situation brought about by an unusual sequence of events.

Intentional Intervention or Ignoring of Protective Systems

In the past, inattention to the task of running the train has caused collisions due to many factors, ranging from use of drugs or intoxicants to merely choosing to perform an unrelated, unimportant task instead of a vital one. Recent attention to drug testing in the U.S. railroad industry has effectively minimized this risk.

Intentional intervention by vandalism can produce total ineffectiveness of portions of system and it has produced many collisions. Adoption of additional technologies can limit the dangerous effect of most acts of vandalism. Cab-without-wayside systems have been adopted for economic reasons, as have microprocessor signal systems, however both remove many potentially dangerous effects of vandalism that could otherwise cause a collision.

The introduction of foreign objects into vital relays, or their inversion by vandals has caused their vital functions to be bypassed, with consequent collisions. Introduction of microprocessor replacements prevents this threat. Inadequate security procedures has allowed vandals to operate switch machines causing collisions, and has been addressed by some Authorities by the introduction of high security locks and keys, and by policy changes. The FRA requires all vital signal apparatus to be locked in a manner to prevent access to unqualified employees, which can result in "accidental vandalism" by personnel.

3.5.3 Predictable Intrusion

The intrusion of animals or obstructions upon the guideway that can be reasonably expected can occur in a variety of ways, as can the inherent threat of collision due to the intrusion. Collisions with a person, or an intentionally placed obstruction by a person, must always be considered a predictable possibility.

People's actions are predictably unpredictable so a level of probability must be assumed when preventive measures are being considered. The types of protection from such intrusions range from signs, fences, barriers, and "cattle guard" roadway, to a fully isolated guideway (tunnel or elevated). Collisions with apparatus being handled by maintenance personnel have occurred and

they should be addressed under proper policies and adequate qualifying procedures for responsible personnel.

3.5.4 Unpredictable Intrusion

This is a presentation of an obstruction that could not be reasonably expected, such as an out-of-control highway vehicle breaching the guideway area or a derailed train on a nearby guideway fouling the guideway. Collisions due to an overrun at the end of the guideway occur for virtually the same reasons as collisions between trains, with human error being the most common. There can be numerous causes for a rail vehicle encroaching from an adjacent track. These include a failure to park such a vehicle in the clear, failure to properly secure a parked vehicle, and assorted accidents on an adjacent track.

Trespassers have intentionally breached fences and jumped from overhead structures to enter guideways with the goal of suicide. Individuals determined to trespass upon the guideway cannot be stopped entirely, though accessibility can be severely curtailed. Events such as these are outside the control of the HSGGT Authority and responsible system design must achieve an acceptable level of "probable intrusion" protection, measured by current public safety standards and economic feasibility.

3.6 SUMMARY

Table 3.1 summarizes the foregoing discussion of vehicle, guideway, and wayside design features, and makes a qualitative assessment about their perceived effectiveness.

Table 3.1. Guideway, Vehicle and Wayside Design Features

Guideway Design Features	<u>Effectiveness</u>	<u>Comments</u>
Grade Separation Structures/ Elevated Guideway	A most effective right-of-way control measure, when used in concert with fences and barriers.	Can be costly, depending on individual application and environment.
Fences and Barriers	An effective measure, when combined with signage and public education elements.	Essential on HSGGT systems right-of-way to prevent unauthorized access and vandalism. Increases the maintenance burden.
Grade Crossing Protection	When grade crossing are allowed, positive active grade crossing barrier interfacing with traffic systems may be effective.	Can be expensive to install and maintain.
Signage	A low cost and effective means for dissemination of information and warnings about HSGGT systems.	
Intrusion Detection	A necessary element of HSGGT systems when natural and environmental risks cannot be eliminated.	Can be expensive to install, operate, and maintain. Risk of false alarms.
End of Guideway Measures	An effective element of HSGGT systems for safe deceleration of trains in critical areas.	
Track Switch Protection	Proper installation and maintenance of switches is highly effective in reducing the number of safety-critical incidents.	Switches require a high level of maintenance for proper and safe operation. A necessary but costly element of the HSGGT maintenance budget.

Table 3.1. Guideway, Vehicle and Wayside Design Features (continued)

	<u>Effectiveness</u>	<u>Comments</u>
Vehicle Design Features		
Visual and Audio Devices	Headlights, audible warning devices and rear end marking devices are highly effective in alerting system personnel and the general public to the presence of HSGGT.	These elements are required equipment in almost every railroad operation.
On-Board Health Monitoring	Sensors detecting mechanical and/or electrical problems can alert either the train operator or a central location. If safety is questionable, the devices can be tied to ATP system to reduce operation level or stop altogether.	Highly recommended for an HSGGT system.
Wayside Design Features		
Hot Box Detectors	Highly effective in alerting train operators to mechanical malfunction of the axle bearings, with possible catastrophic consequences. Should be considered necessary equipment.	Can be relatively expensive to install and maintain. May increase the maintenance burden.
Hot Wheel Detectors	Highly effective in alerting train operators to overall HSGGT system malfunction, with possible catastrophic consequences.	Can be relatively expensive to install and maintain.
Derailment/Dragging Equipment Detectors	Highly effective in alerting train operators to overall HSGGT system malfunction, with possible catastrophic consequences.	Other mechanical/electrical systems may also serve a similar function.
Critical Clearance Detectors	Highly effective in alerting train operators to overall HSGGT system malfunction, prior to entering major fixed facilities. Should be considered necessary equipment for major fixed facilities to prevent damage to trains and/or facilities with possible catastrophic consequences .	Can be relatively expensive to install and maintain.

4. EFFECT OF COLLISION AVOIDANCE MEASURES ON SYSTEM OPERATION

4.1 INTRODUCTION

In previous sections of Volume 2 of this report, various methods of collision avoidance have been discussed -- methods currently in use or under consideration on both conventional rail and high-speed rail systems throughout the world. In this chapter the effects these methods have on the overall operation of a system are addressed.

In particular, two important areas of system operation will be highlighted:

- *Maintainability and Reliability.* The more maintainable and reliable an element is, the more likely it is to be used properly. For example, a fail-safe system can only prevent accidents if it is used. If it is so difficult to maintain or if it breaks down so often that it is not used, it does not matter how fail-safe the system is. Many of the elements new to the industry do not have quantitative measures of maintainability and reliability readily available. In such cases, this chapter provides a qualitative view of the general design impact on both reliability and maintainability.
- *System Capacity.* The interrelationship of operational elements -- such as minimum spacing of trains (headway), block design, braking distance, and control systems -- and their relation to the line capacity are discussed below. The high speed of a train should lead to increased capacity because it decreases trip time. However, unless block lengths are significantly shortened, raising speeds actually lowers capacity because of the greater braking distances required. Line capacity is affected by and sometimes limited by the interaction of these elements.

These two areas -- maintainability and reliability, and system capacity -- will be considered here in relation to four operational areas:

- *Route integrity measures,* which include train detection (track circuits, transponder systems, onboard detection sensing, and satellite locating systems) and interlocking (vital relays, solid state interlockings) and is affected by interlocking architecture.
- *Signaling methods,* which include signaling and speed signaling.
- *ATP speed enforcement,* which includes onboard speed control and train braking.
- *Guideway design measures,* which include grade crossing protection, and intrusion and mechanical detection devices.

4.2 ROUTE INTEGRITY MEASURES

4.2.1 Train Detection

1. Track Circuits

The traditional track circuits discussed in Chapter 2 are still the most common method of train detection in both U.S. and foreign systems, and they are used in high-speed systems, the Shinkansen and the TGV, as well.

Maintainability and Reliability of Track Circuits

Track circuits in U.S. transit applications are typically subjected to routine testing and inspection every six months to verify that signal levels are within tolerance and that detection occurs under all circumstances. Circuits that require insulated joints require rail joint inspection and maintenance, usually monthly but sometimes weekly.

Often conventional track circuit inspection is less than that performed on some high-speed systems. For example, on the SNCF high-speed lines in France, a test car called "Helene" routinely makes a monthly trip over all the lines to monitor the condition of track-train communications and train detection systems.

The diagnostic capability of the microprocessor coded circuit, one of the types described earlier, is currently being touted throughout the transit industry as a big advantage of microprocessor control. The processor can be programmed to give warnings of signal level fluctuation or to help isolate component failures through diagnostic routines.

Reliability numbers for track circuits used for train detection can vary widely, depending on maintenance, grade crossings, and vandalism (grade crossings can introduce indeterminate factors such as road salting that can affect track circuits). Many times the circuits are quoted at relatively high levels, but lower reliabilities are also reported on the order of 1 operational (i.e., "safe") failure per 200 circuits per year. This element of train detection is one of the most common failures within an ATP systems.

Impact of Track Circuits on Capacity and Operations

One of the disadvantages of detection by track circuit is the fact that train position can only be detected as accurately as the track circuit length. This limitation increases the minimum headway attainable.

Typically, for conventional rail systems, 90 second headways are the minimum attained. MARTA and the Atlanta Airport APM are typical examples. These systems' 90-second headways are based on:

- Maximum stopping times of around 50 to 60 seconds from maximum speed to zero, plus extra time for traversing a block (see Figure 4-1).

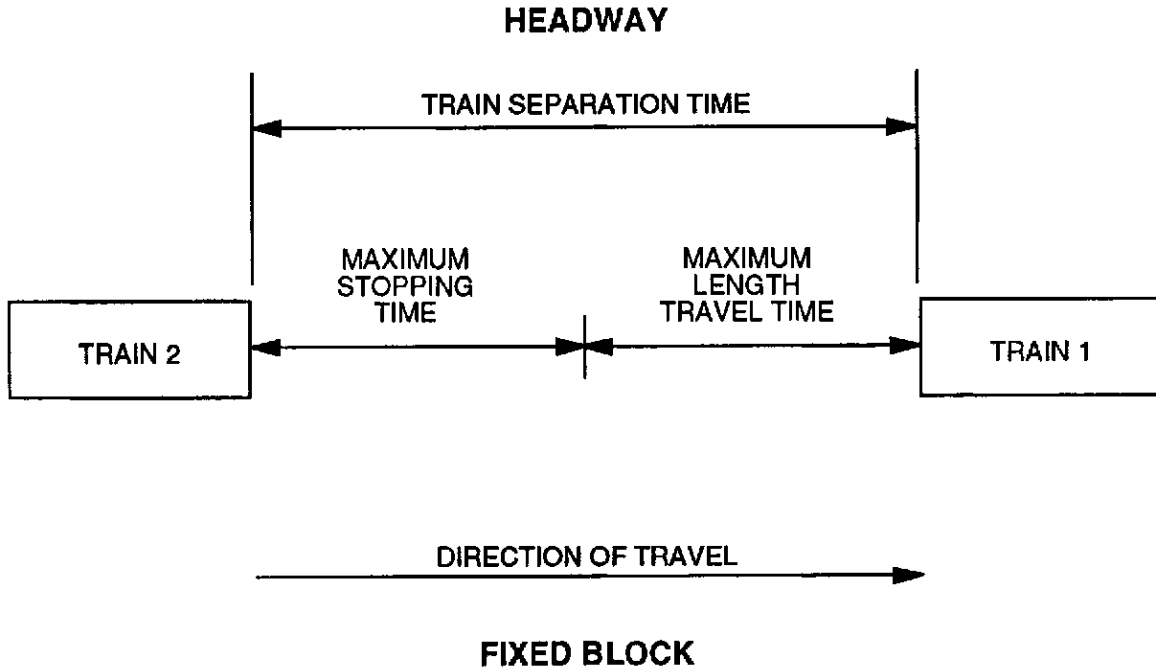

Figure 4.1. Minimum Headway in a Fixed Block System

- Maximum speeds of 110-130 km/h (70-80 mph), usually.

As the speed of the train is increased, the maximum stopping distance and time are increased. Some shortening of track circuits is possible, even though this involves extra equipment and thus higher capital and maintenance costs, and decreased system reliability. However, the headways will most likely be increased on high-speed systems.

For example:

- If the maximum speed is 110 km/h (70 mph) and the maximum block length is 610 meters (2,000 feet), the time to travel the length of the block is 19.6 seconds. If the braking time is considered to be approximately 50 seconds, then the minimum headway is 69.6 seconds.
- If the maximum speed is increased to 200 km/h (125 mph), the time to travel the length of the 610m (2,000-ft) block decreases to 11 seconds, but the braking time may increase to 83 seconds (assuming standard industry brake rates), giving a minimum headway of 94 seconds.

Obviously, a shorter track circuit would make only a small impact on headway in this example.

If fixed length track circuits are to be used on high-speed systems, the capacity requirements and consequent headway requirements must be weighed carefully against the amount of equipment required to provide the block lengths needed. Moving block systems and added braking capacity may be required to meet capacity requirements. These changes are discussed in following sections.

2. Transponder Systems

Maintainability and Reliability of Transponder Systems

As used by British Rail, Transrapid INKREFA, and Union Pacific, this method of detection relies on a mainly passive roadway element -- the wayside transponder that is designed to couple magnetically with the onboard interrogator. This type of transponder is also used for non-vital applications, such as programmed stop markers. These transponders are noted for high reliability because very little hardware is required. A typical specification may quote numbers such as 1 failure per 60 units per 3 years.

Because they are not used for vital detection purposes routinely in the United States, it is difficult to determine how often the transponders should be maintained. For properties where transponders are currently used as non-vital markers, checks for proper frequency tuning are performed only about once a year.

The train portion of this system, the interrogator and the radio or digital transmission system, becomes very important when used for the vital function of detection. If transponders are to be considered part of the ATP system, a daily departure test may be advisable. This requirement would not significantly affect maintenance because most radio systems are normally tested on a daily basis anyway. The reliability of a train communication system is quoted in several U.S. transit vehicle specifications on the order of 3 failures per unit per year, which is a considerably higher failure rate than some other components but includes the public address speakers, intercoms, etc. The actual radio component itself would obviously have a better reliability.

If the transponder is used as an active device which receives information from the train, health monitoring or diagnostic data can be passed from the train to the wayside, aiding in troubleshooting and maintenance scheduling.

If the transponder is passive, this type of information can be transmitted over the radio or digital data link from the train.

Increased rail inspection may be required or some other method of detection provided because the transponder does not detect broken rails.

Impact of the Transponder System on Capacity and Operations

If the transponder is used by itself for location, it will place the same restrictions on system capacity and headways as the track circuit. It depends on transponder spacing.

Use of the transponder with an additional onboard device which calculates distance from the transponder makes absolute location of a train theoretically possible and also makes a decrease in headway times possible by the moving block principle (see Figure 4.2).

One of the disadvantages of this type of detection is the absolute dependency on the communication link from the train. If a radio system is used and the radio system goes down, the entire operation must be stopped unless some back-up detection system is provided. The possibility of this happening can be minimized by providing more than one base station and backup batteries or power supplies for radio equipment.

Another disadvantage, from a system operation standpoint, is that no detection of individual cars is provided unless each car is outfitted with detection equipment. This means that making and breaking of trains is not as easily accomplished. This effect could be mitigated by providing other methods of detection, such as track circuits, in storage areas.

3. Onboard Detection Sensing

This type of detection is almost an extension of the transponder system, where the train is provided with a location identity and then calculates its distance from that reference point.

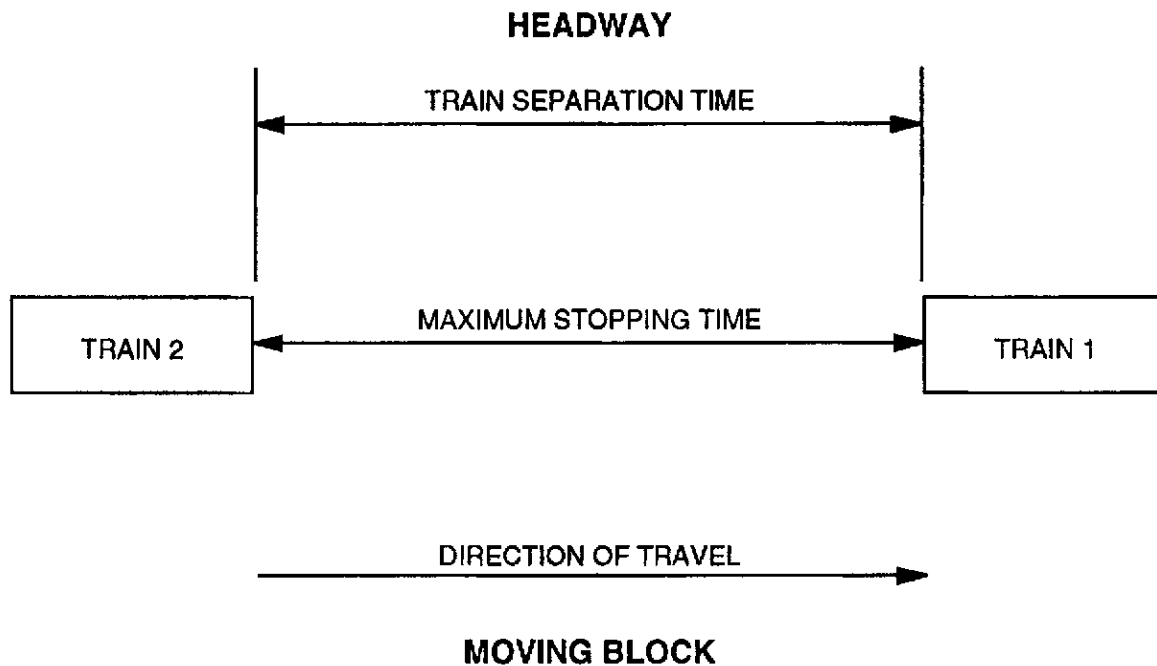

Figure 4.2. Minimum Headway in a Moving Block System

Maintainability and Reliability of Onboard Detection Sensing

Many of the applications of this type of sensing have experienced significant problems. The SNCF ASTREE System is still in the development stages and information on its reliability is not available.

This type of system is also being used on the German ICE trains. Even though an overall 99.8 to 99.9 percent availability is reported per loop, the predominant cause of system nonavailability is the positioning system, which is based on wheel revolutions where slipping at the wheels is possible.

On the London Docklands Light Railway (DLR), the location reference is based on exchange of data between the train and the wayside over a Data Docking Link. The DLR has experienced significant reliability problems with this link and the cause is still under investigation. As with the ICE, problems have also been experienced with locating based on wheel revolution on account of susceptibility to slip/slide errors.

Some of the positioning errors may be eliminated by a system such as the Doppler radar system being developed on the ASTREE System. This method depends on a communication link from the train to the Control Center, so concerns exist about the reliability of this communication system similar to those for the transponder system.

Impact of the Onboard Detection Sensing on Capacity and Operations

Onboard detection sensing can be applied to a moving block type of speed command system and thus offers a potential for some improvement in headways.

4. Satellite Locating System

Maintainability and Reliability of the Satellite Locating System

The Burlington Northern (BN) Advanced Railroad Electronics System (ARES) locating system uses the Navstar satellites provided for the Department of Defense's Global Positioning System (GPS). This locating system depends on reception of frequencies transmitted from three different satellites at one time. The receiver can lock on to four or more satellites, however, which provides continuity when a signal is lost from another satellite.

Reliability numbers have not been established because this type of system is still under development. The commitment to this program made by the Department of Defense since 1972 indicates that this system will be developed into a highly reliable one. This system provides some definite maintenance advantages because no wayside location detection equipment is required (except in double track territory, as described in the next section).

The onboard train receivers will require a more sophisticated approach to train maintenance than the simple shunt used in track circuits, and as with the transponder system, the communication link (radio, for example) from the train back to the control center must be made extremely reliable.

Impact of the Satellite Locating System on Operations

Currently, this type of system has three serious limitations on system operations.

- *Positioning Tolerance.* The positioning tolerance is about 30 meters, based on satellite security considerations, not actual obtainable accuracy. Over time, commercial applications will become more accurate as other ways of ensuring satellite position security are implemented. Although this is not a severe restriction on following moves, it could be a problem in double track territory. U.S. applications of high-speed trains will probably need to be double tracked, largely depending on the headway required to meet line capacity. BN's system relies on a ground-based detection system, e.g., track circuits, where parallel tracks are used.
- *Loss of Signal.* When a train travels under an overpass or into a tunnel, the GPS signal is lost. Therefore, a supplemental positioning system must be used in obscured areas. At present there is a delay in reestablishing position once an interrupted signal is picked up again. This latter problem is being addressed using advanced processing software which is expected to solve this problem.
- *Limited Number of Satellites in Orbit.* There are currently eighteen available (as of October 1992) and they provide detection of position for only 22 hours a day. This limitation is projected to be removed by the end of 1993 when full 24-hour operation will be possible.

The satellite locating system lends itself to the moving block concept and its inherent higher capacity. At higher speeds, however, the time to traverse a given block length is shorter. As one can see from Table 4.1, elimination of fixed blocks (whose length is normally a maximum of 610 to 1,524 meters (2,000 to 5,000 feet)) may make a difference of only 10 seconds or so in headway.

One might conclude from this that moving block is of less value on HSGGT where braking distances are long relative to block length than in a transit application where stopping distance may be much less than a block; however, because of the number of signal aspects required in HSGGT fixed block operations, it may still be quite advantageous to consider moving block here also.

Table 4.1. Distance Traveled vs. Speed

Speed		Distance Traveled in 10 Seconds
480 km/h	(300 mph)	1340m (4,400 ft)
400 km/h	(250 mph)	1120m (3,667 ft)
320 km/h	(200 mph)	890m (2,933 ft)
240 km/h	(150 mph)	670m (2,200 ft)

4.2.2 Interlocking

1. Vital Relay Interlocking

Maintainability and Reliability of Vital Relay Interlocking

Vital relays have a failure rate of about 1 every 50 years. When vital relays fail, they tend to fail in a safe manner. Depending on the type of relay, testing and inspection are routinely performed only once every 1 to 6 years, per 49 CFR Part 236. Changing a vital relay interlocking is also easier than changing a solid state interlocking at present, not due to the change itself, but because only the affected portion must be operationally tested after the change. A software change in a solid state interlocking presently requires a complete operational test of the entire area covered by the interlocking.

Impact of a Vital Relay Interlocking on Capacity

The line capacity of a system is not limited by the vital relay interlocking technology except by cost. The vital relay system has been used successfully on the TGV, Shinkansen, and ICE systems. When the equipment failure does occur, it can temporarily halt operations unless run-around scenarios are possible. Replacement of a relay involves only a short delay time, however, on the order of an hour, depending upon location of maintenance personnel and parts.

2. Solid State Interlocking (SSI)

Maintainability and Reliability of Solid State Interlocking

The SSI designs in both the United States and Europe quote high reliability figures and many installations have been implemented successfully. The vital microprocessor interlockings provided by Union Switch and Signal Co. have failure rates from as low as 2.03 system failures per million hours for a fully redundant system to as high as 185 system failures per million hours for single input/output rack with dual CPUs. This corresponds roughly to the equivalent of 200 vital relays for a typical double crossover interlocking. (A direct comparison is difficult to provide, since each application is different.)

Note, however, that not all vital relays are replaced in the present SSI system. Anywhere between 60 to 80 percent of vital relays required for an interlocking function are presently replaced by SSI. Vital relays are still used in speed code select circuits and switch control circuits, for example.

Current American microprocessor systems rely upon self-testing of a single CPU and force a system shutdown of vital systems when any error occurs within vital logic, in order to achieve fail-safe vitality. European technologies use a more fault tolerant system, comparable to vital systems employed in the U.S. Defense Department technologies whereby a system shutdown is not affected by all vital errors encountered. The fault tolerant system employed in European systems is accomplished by means of redundant CPU methods often providing uninterrupted operation even though a software or hardware fault has occurred.

Several problems arise with the use of SSIs:

- *Lightning Susceptibility.* The solid state interlockings installed in Washington, D.C., and Chicago have proved susceptible to lightning. Therefore, special lightning protection must be provided for these electronic devices.
- *Extensive Testing After Changes.* As mentioned previously, the SSI is not changed as easily as the vital relay interlocking because of the requirement to test the operation of the entire interlocking completely after a software change. However, the microprocessor-controlled and modularly designed solid state system is normally provided with built-in fault isolation and diagnostic aids to assist in maintenance. Field maintenance on U.S. railroads has been limited to replacement of failed boards, with board repair performed by the manufacturer or a special electronic repair facility.

Impact of Solid State Interlocking on Operation

SSI does not restrict the system capacity by its design. It may be preferable to vital relay interlocking on highly complex systems because it is less expensive from a capital cost standpoint and takes less equipment space per function provided.

4.2.3 Interlocking Architecture

In Section 2 it was noted that interlocking may be either automatic or remotely controlled, a difference that corresponds roughly to the concept of decentralized versus centralized interlockings, referred to here as interlocking architecture.

Maintainability and Reliability of Interlocking Architecture

Virtually all vital interlocking functions in the U.S. are provided locally, at the interlocking. These functions are typically provided with a Central Instrument House (CIH) or Train Control Room (TCR), with the interlocking often referred to as a Control Point (CP) when a centralized non-vital control facility is provided. Vital processing can occur within a relatively small area, limiting vital communications between devices to signal cable (i.e., no special communications equipment). This increases reliability because there is less potential for breakdown within the vital system area. A vital signal cable or vital communications link (often provided by microprocessor-based track circuits) conveys the data necessary between two adjacent interlockings to provide route integrity and proper signaling. In the event of a communications failure between any CP and a central control facility, vital operations can continue without inhibiting any vital functions by providing a local panel for such operations.

Vital relay based interlockings are the most common in the U.S., and are highly reliable. The various tests required on the equipment are performed at intervals of one, three, and six months, and one, two, and four years per FRA regulations. Generally, the relay interlockings, with a centralized non-vital control facility are easily maintained and tested, through requiring considerably more maintenance than a solid state interlocking. Most tests performed on vital functions require either the inhibition of safety functions or the simulation of failures to prove

proper system operation. Generally, most operational devices are systematically replaced as inspections indicate the necessity, before they can adversely affect operations.

A solid state interlocking generally requires similar maintenance and testing, though many tests are no longer applicable. With the absence of what is often many miles of wiring and moving devices, many potentials for failures (safe, operational failures) are reduced. Backup systems, and/or redundant CPU type systems can prevent spurious errors, so that failures within the system do not interrupt operations. Depending upon the interlocking configuration and the use of multiple microprocessor units, a layout can be such that a microprocessor shutdown can be accommodated without a total operational shutdown. From the point of view of maintenance, solid state devices cannot be predictably removed and replaced prior to failure. Therefore, architecture and backup facilities should provide a method of safe, virtually continuous operation to alleviate the impact of component failure.

Impact of Interlocking Architecture on System Operation

The decentralized interlockings (used by MARTA, WMATA, and CTA to name a few) have relied on a traditional track circuit method of detection, and detection is performed locally in the train control room. If detection is performed at a central location, such as has been done on the ICE system, then a loss of the central control location will halt system operation regardless of the interlocking location, because detection is lost. Thus if system capacity requirements mandate a moving block system, then detection communications must be provided at decentralized locations if decentralized interlocking is to be used.

4.3 SIGNALING METHODS

It is universally accepted that wayside signals alone are insufficient for a high-speed system, although they have been traditionally used for conventional rail operations. For this reason, only cab signaling and onboard signaling are discussed below.

4.3.1 Intermittent Cab Signaling

Maintainability and Reliability of Intermittent Cab Signaling

Intermittent cab signals do not appear to have an advantage in maintainability or reliability over continuous signals where track circuit detection is employed, since the track circuits themselves may be used for transmission. Because of the capacity restriction discussed in the following section, it is unlikely that intermittent signaling will be used for high-speed, even though the Shinkansen does employ intermittent signals.

Impact of Intermittent Cab Signaling on Capacity and Operations

The intermittent method of signaling adds a further restriction on headway because the time to travel the distance between signals must now be added to the braking time and the block length traversal time. For example:

- In Figure 4-3a, when Train 2 approaches Block 1, Block 2 is occupied by Train 1 and Train 2 will get a stop command so it does not enter Block 2.
- In Figure 4-3b, when Train 1 enters Block 3, Train 2 can resume acceleration until it reaches Block 2, but it does not receive a new signal until it stops at the approach to Block 2, so it falls farther behind Train 1.

Obviously, this is an oversimplification of the block system, but it demonstrates the additional capacity restrictions of an intermittent approach to signaling. For high density operation, these types of restrictions are not desirable.

4.3.2 Continuous Cab Signaling

Maintainability and Reliability of Continuous Cab Signaling

The equipment used to perform continuous cab signaling is most often the same equipment used to provide train detection. For this reason, its impact on maintainability and reliability corresponds to that of the detection method, discussed previously in this chapter.

Impact of Continuous Cab Signaling on Capacity and Operations

As discussed earlier, any high-speed system will almost certainly employ continuous cab signaling because of its ability to allow closer following moves. The capacity of a system that provides a large degree of speed command selection can be increased over the capacity of a system with only five or six possible speed commands. (An example of a system with a large degree of speed command selection is the moving block type system, SELTRAC, being provided for the new ATC system for Dockland Light Railway, which allows speed command reductions in approximately 4.8 km/h (3 mph) increments.)

The greater speed command selection allows a speed much closer to the actual restriction to be commanded. For example:

- If a curve required negotiation at a maximum speed of 105 km/h (65 mph) and the speed commands available were 115, 90, 65 km/h, etc. (70, 55, 40 mph, etc.) -- with gradations of 25 km/h (15 mph) and fewer commands -- a 90 km/h (55 mph) limit would have to be enforced prior to entering the curve.
- If the available commands were 115, 110, 105 km/h (70, 67, 64 mph) -- with gradations of 5 km/h (3 mph) and more commands -- a 105 km/h (64 mph) limit could be enforced with an overall travel time savings as well.

4.4 ATP SPEED ENFORCEMENT

The following discussions are restricted to those systems that might be used on a high-speed line so trip stops are not discussed.

Figure 4.3a

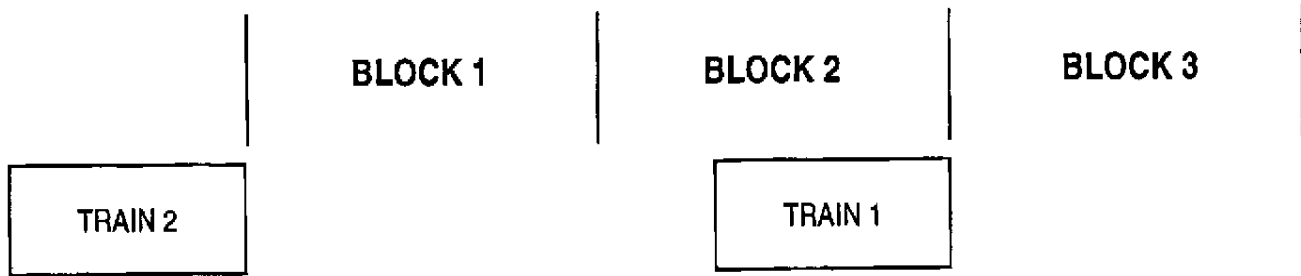

Figure 4.3b

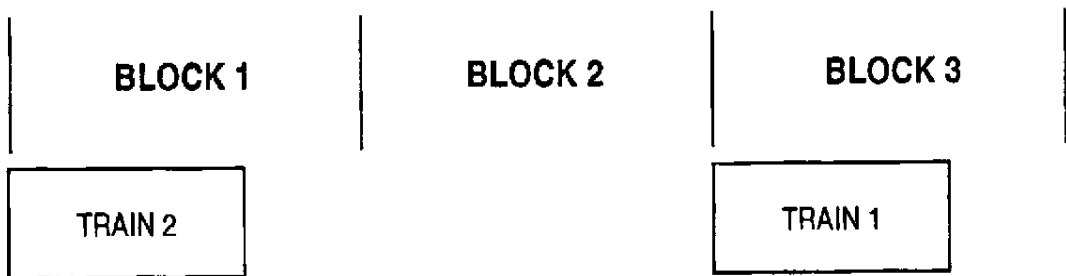

Figure 4-3. Intermittent Cab Signaling Impact on Capacity and Operations

4.4.1 Onboard Speed Control

Maintainability and Reliability of Onboard Speed Control

The reliability impact of the onboard automatic train control system is difficult to assess because so many types of system are employed. For example:

- A typical transit vehicle specification, such as that used by MARTA, quotes a mean time between failure of 1,000 hours, but this figure includes ATO functions.
- A newer system, such as the London Docklands Light Railway, has experienced so many incidents, however, that the entire train control system (onboard and wayside) is being changed to a new SELTRAC system.
- The German ICE onboard system employs the two out of three microprocessor-based LZB system and they quote a very high availability of 99.8 to 99.9 percent.

Those systems that provide ATP, but not ATO, would probably have a higher reliability due to the smaller quantity of equipment. The recent trend in onboard control has been to use microprocessors with built in diagnostics to assist in maintenance and troubleshooting. These systems have also been designed to step the train automatically through the departure test required by the FRA.

Impact of Onboard Speed Control on Capacity and Operations

Incorporation of ATO with ATP in an onboard control system has allowed some improved capacity on rapid transit and people mover systems where extra 5 to 10 second delays per start and stop make a difference in overall trip time. These 5 or 10 second differences that may come from varying human reaction times become insignificant with high-speed trains, however, where long distances and long times are expected between stops. The ATO does provide consistency and quick response to changes. If ATO is chosen, it is important for a system to provide adequate manual backup so that a train operator can still drive the train at maximum ATP speed if the ATO system is non-functional. This means a speedometer as well as ATP speed indication must be visible to the train operator.

4.4.2 Train Braking

Speed -- and all its effects that inhibit the safety of the system -- make designing an HSGGT system differ from a designing a conventional railroad system. Therefore, braking requirements re a key factor in a high-speed system. See Table 4.2 for comparison of typical brake distance and time requirements of the two types of systems.

Passenger compartment deceleration increases approximately proportionally to the impact speed. This important factor requires an HSGGT system to be able to minimize speed as quickly as possible if the potential point of impact is closer than conventional safe or emergency braking distance. Speed certainly does affect the severity of a collision and therefore the fatalities resulting from collisions; hence, the slower the speed of a collision the more survivable it will

be. The performance of the braking systems is definitely a key element in the overall collision avoidance and accident survivability of an HSGGT system.

- Table 4-2 reflects immediate braking requirements that are met without any reaction time required by a train operator. This table depicts typical train deceleration that could be achieved when reaction times are removed from the system by means of state-of-the-art technologies.
- Table 4-3 depicts the same braking distances with two important factors added, equipment reaction and delay of enforcement to provide for human reaction.

Conventional onboard cab signal equipment may take up to three seconds (though typically under two seconds) to display the new cab signal aspect properly after receiving it. Conventional systems expect a train operator to take approximately four seconds to react, and allow up to a total of eight seconds prior to enforcing braking.

Emergency braking systems, however, typically make up for the distance lost in braking distance by applying brakes at the higher emergency rate, where the engineer would have used the lower service rate.

Maintainability and Reliability of Train Braking

Train braking must be fail-safe. The FRA and the UIC require testing as part of a daily departure routine to ensure braking rates are as required. FRA maintenance regulations require daily inspection and scheduled maintenance that must be done every 92 days, 12 months, and 24 months. These required maintenance tasks are considered part of the verification of the safety system. Currently, testing is typically carried out according to the procedures outlined in Appendix E, Train Brake Inspection and Testing. As health monitoring systems become increasingly more sophisticated, the need for and level of inspection and testing maintenance will decrease.

Friction brakes are normally considered the fail-safe element of train braking. In some high-speed applications, efforts have been made to increase the minimum guaranteed brake rate by using the dynamic or electric brake, and an eddy current brake. Use of these types of measures on U.S. high-speed trains would assuredly increase the maintenance requirements for the braking system.

The reliability of a brake system is not extremely high and thus can increase fleet maintenance requirements. For example:

- One transit vehicle specification quotes a Mean Time Between Failures (MTBF) of 1,095 hours for the friction brake system and 820 hours for the propulsion system (which includes dynamic braking).
- On the ICE system, an eddy current braking system produced interference with the signaling and so was not installed on the first series of trains.

Table 4.2. Braking Time and Distance Tables

Non-HSGGT

HSGGT

Comfortable Service Braking .914 mps² (3.0 fps²) Deceleration

Speed:		Distance:		Time:	Speed:		Distance:		Time:
km/h	(mph)	m	(ft)	sec	km/h	(mph)	m	(ft)	sec
105	(65)	462	(1515)	32	209	(130)	1848	(6062)	64
113	(70)	536	(1758)	34	225	(140)	2143	(7030)	68
121	(75)	634	(2018)	37	241	(150)	2460	(8070)	73
129	(80)	700	(2296)	39	257	(160)	2799	(9182)	78
137	(85)	790	(2591)	42	274	(170)	3159	(10366)	83
145	(90)	885	(2905)	44	290	(180)	3542	(11621)	88
153	(95)	987	(3237)	46	306	(190)	3946	(12948)	93
161	(100)	1093	(3587)	49	322	(200)	4373	(14347)	98

Emergency Braking at 1.372 mps² (4.5 fps²) Deceleration

Speed:		Distance:		Time:	Speed:		Distance:		Time:
km/h	(mph)	m	(ft)	sec	km/h	(mph)	m	(ft)	sec
105	(65)	308	(1010)	21	209	(130)	1232	(4041)	42
113	(70)	357	(1172)	23	225	(140)	1428	(4687)	46
121	(75)	410	(1345)	24	241	(150)	1640	(5380)	49
129	(80)	466	(1530)	26	257	(160)	1866	(6121)	52
137	(85)	527	(1728)	28	274	(170)	2106	(6911)	55
145	(90)	590	(1937)	29	290	(180)	2361	(7748)	59
153	(95)	658	(2158)	31	306	(190)	2631	(8632)	62
161	(100)	729	(2391)	33	322	(200)	2915	(9565)	65

'Smart' Ultimate Braking at 2.286 mps² (7.5 fPs²)

Not Applicable to Non-HSGGT Systems	Speed:		Distance:		Time:
	Km/h	(mph)	m	(ft)	sec
	209	(130)	739	(2425)	25
	225	(140)	857	(2812)	27
	241	(150)	984	(3228)	29
	257	(160)	1119	(3673)	31
	274	(170)	1274	(4146)	33
	290	(180)	1417	(4649)	35
	306	(190)	1579	(5179)	37
322	(200)	1749	(5739)	39	

Service and emergency braking rates shown are typical for systems in use today. Ultimate braking applications require vital processing knowledge of imminent collision, a procedure to minimize impact or prevent collision at the risk of onboard injury due to extreme forces. Ultimate brake rate is hypothetical, and may be higher or lower based upon systems used, and level of "smart braking" logic.

Table 4.3. Emergency Braking Time and Distance Tables with Cumulative Reaction Time and Distance

Non-HSGGT

HSGGT

Conventional Cab Signal System, Braking Enforcement Activated, with 11 Seconds Accumulated Time Prior to System Enforcement.

Emergency Braking at 1.372 mps² (4.5 fps²) Deceleration

Speed:		Distance:		Time:	Speed:		Distance:		Time:
km/h	(mph)	m	(ft)	sec	km/h	(mph)	m	(ft)	sec
105	(65)	628	(2059)	32	209	(130)	1871	(6139)	53
113	(70)	702	(2302)	34	225	(140)	2117	(6946)	57
121	(75)	779	(2555)	37	241	(150)	2377	(7800)	60
129	(80)	860	(2821)	39	257	(160)	2653	(8703)	63
137	(85)	945	(3100)	42	274	(170)	2942	(9654)	66
145	(90)	1033	(3389)	44	290	(180)	3247	(10653)	70
153	(95)	1125	(3691)	46	306	(190)	3565	(11698)	73
161	(100)	1221	(4005)	49	322	(200)	3899	(12792)	76

Alternate Speed Transmission (time/distance from location of speed command) with 8 Seconds Accumulated Time Prior to System Enforcement.

Emergency Braking at 1.372 mps² (4.5 fps²) Deceleration

Speed:		Distance:		Time:	Speed:		Distance:		Time:
km/h	(mph)	m	(ft)	sec	km/h	(mph)	m	(ft)	sec
105	(65)	540	(1773)	29	209	(130)	1697	(5567)	50
113	(70)	608	(1994)	31	225	(140)	1929	(6330)	54
121	(75)	678	(2225)	32	241	(150)	2176	(7140)	57
129	(80)	752	(2469)	34	257	(160)	2438	(7999)	60
137	(85)	931	(2726)	36	274	(170)	2714	(8906)	63
145	(90)	912	(2993)	37	290	(180)	3005	(9861)	67
153	(95)	009.	(3273)	39	306	(190)	3311	(10861)	70
161	(100)	1087	(3565)	41	322	(200)	3631	(11912)	73

'Smart' Ultimate Braking at 2.286 mps² (7.5 fps²)

Not Applicable to Non-HSGGT Systems	Speed:		Distance:		Time:
	km/h	(mph)	m	(ft)	sec
	209	(130)	1204	(3951)	33
	225	(140)	1358	(4455)	35
	241	(150)	1520	(4988)	37
	257	(160)	1692	(5551)	39
	274	(170)	1982	(6141)	41
	290	(180)	2061	(6761)	43
	306	(190)	2258	(7409)	45
	322	(200)	2465	(8086)	47

Distances shown exclude the extra block length that must be added for fixed-block signaling situations.

Impact of Train Braking on Capacity and Operations

Train braking probably has one of the biggest impacts on high-speed line capacity because braking distance and duration at higher speeds becomes the largest component of minimum headway time. As mentioned above, improved braking rates through "fail-safe" electric braking and eddy current brakes are hoped to lessen this restriction.

Train brake rates assumed in maximum stopping distance calculations are normally around 1.22 m/s² (4.0 ft²), based on worst adhesion conditions and assuming some percentage of brakes to be inoperative. The addition of dynamic braking into this calculation may somewhat improve the distance and time, but it remains braking at the wheels and requires friction (adhesion).

The most likely candidate to improve braking rates will be an adhesion-independent device, such as the eddy current brake. The main hurdle for implementation of such a device is to make it fail-safe. The eddy current brake on the new ICE-M cars is being provided by a Knorr brake.

4.5 GUIDEWAY DESIGN MEASURES

Some of the elements of the guideway design measures discussed in Chapter 3 have no real influence upon HSGGT system capacity, maintainability, or reliability. These elements include grade separation structures, fences and barriers, and signage. Other guideway design measures that can affect system operation and are discussed below.

4.5.1 Grade Crossing Warning Devices

Grade crossings, which in any case are not recommended, can severely impact train operation.

Maintainability and Reliability of Grade Crossing Warning Devices

Grade crossing warning systems reinherently maintenance intensive because crossing gates can be broken off by vehicular or pedestrian traffic, the gate control mechanism can malfunction and a host of other problems can occur.

Impact on Capacity of Grade Crossing Warning Devices

The presence of grade crossings on HSGGT systems could seriously limit the capacity of the system. At present, the maximum operating speed on railroads with grade crossings is 200 km/h (125 mph). If this arbitrary maximum speed were followed on HSGGT networks, a speed restriction would exist at every grade crossing with inherent deceleration and acceleration requirements.

When vehicle detection systems (induction loops) are used in concert with active warning devices, as is used in Sweden, a train could be stopped by the ATP system whenever a vehicle is detected on a particular crossing. Consequently, adequate distance for safe stopping would be required, affecting minimum headways and capacity.

4.5.2 Intrusion and Mechanical Malfunction Detection Devices

Any of the intrusion and mechanical malfunction detection devices discussed in Chapter 3 have the potential to stop trains and severely impact train operation. Their use also increases instances of train delay due to "false claims."

Maintainability and Reliability of Intrusion and Mechanical Malfunction Detection Devices

These devices should be visually inspected monthly as part of a preventive maintenance program.

The reliability of these devices should be sufficiently high to ensure that they can perform their intended function as necessary, without disruptive false alarms.

Impact on Capacity of Intrusion and Mechanical Malfunction Detection Devices

These detection devices would be linked to the ATP system. Consequently, trains could be stopped whenever an "incident" (i.e., an intrusion of some sort onto the HSGGT right-of-way or some type of mechanical malfunction) is detected and relayed to the appropriate control point. If many false alarms occur, system capacity could be greatly reduced and overall system integrity would be diminished. "Normal" occurrence of intrusions should have little impact because their incidence should be relatively infrequent.

4.6 SUMMARY

HSGGT systems will differ in many respects from conventional rail systems in operation in the United States. One of the most significant differences will be the amount of time that a train operator or a central control operator will have to achieve a safety function if an unsafe condition develops. For this reason, a serious reliance will have to be placed on electronic equipment to detect, verify and command a safety function. The reliability of the equipment is critical because at high speeds operators can no longer be depended upon to "see" the condition to confirm it as a backup measure. They may be too far away from the situation causing the emergency. Therefore:

- Improvements will need to be made in existing U.S. equipment.
- New standards will be needed for inspections with respect to intervals, training, and operational procedures.
- An organized and structured approach will be needed in the areas of reliability, maintainability, maintenance, and training in order to bring the U.S. operations to the level needed to support the system safety parameters for high-speed service.

5. RECOMMENDED GUIDELINES FOR COLLISION AVOIDANCE EVALUATION

5.1 INTRODUCTION

Current and proposed technologies for collision avoidance systems are discussed in Chapters 2, 3, and 4. In this chapter, the following topics are discussed:

- The four collision scenario groups are reviewed, and current U.S. and worldwide technologies applicable to avoiding collisions in each category are discussed.
- HSGGT system requirements are first broadly and then specifically evaluated.
- Other considerations, such as reliability calculations, maintainability, testing, and training are addressed.
- Finally, methods of system performance evaluation are addressed.

5.2 COLLISION SCENARIOS REVIEWED

5.2.1 Group 1: Train-Train (Same Track) Collision Avoidance

1. Introduction

This collision scenario group addresses three basic types of collision between two trains occupying the same track, or a point where two adjacent tracks meet:

- *Head to head*, with meeting speed being the sum of both train speeds
- *Head to tail*, with meeting speed being the difference between the two train speeds
- *Head to train*, covering all points where two track sections meet in some manner, with meeting speed being decided on the basis of configuration.

In an HSGGT system, the potential must be considered for requiring different emergency braking rates based upon the potential collision and severity of impact. New high-performance braking systems may emerge as HSGGT technology develops that will enhance the system safety. The following major systems are required by a collision avoidance system:

- Interlocking integrity systems
- Train detection
- Proper speed conveyance based upon safe braking distance
- Proper engineer response (with or without action enforcement techniques)
- Vehicle braking (and enforcement)

Failure of any subsystem (defined in 2.2) can result in the lack of complete, acceptable protection, and requires an alternative method that overrides part, or all, of the collision avoidance system. Maintaining the highest possible protection should be a requirement in any HSGGT system when a component has failed. System development has increased to present levels largely because of human mistakes. Such mistakes must be expected and addressed in an HSGGT system before they occur, especially when safety systems must be overridden.

Future HSGGT systems will require collision avoidance systems that begin with the history of developments in the field, but achieve standards based upon all available current technologies. Acceptable levels of collision avoidance in this scenario, for example, were not reached until technologies improved, allowing fail-safe vital circuitry to ensure that the potential for conflict was reduced. Train detection interfaces with signals conveying speed to the operator to insure proper separation between two trains on the same track. Collisions in this situation (with all necessary equipment adequately provided) have often been caused by key personnel acting improperly for a variety of reasons. This has resulted in changes in regulations and the establishment of enforcement techniques (such as ATP).

2. Current U.S. Methods and Levels

Collisions in this situation are currently protected against by established fail-safe technologies that provide train separation distances that ensure a collision of this sort cannot occur. Collisions that do occur in this scenario group share most methods of avoidance with the other three scenario groups discussed here.

Vital train detection forms the foundation required to prevent collisions of this type.

- Speed conveyance to the rear train must vitally insure a separation is maintained that provides safe service braking distance in order to prevent collisions of head-to-tail type.
- The requirements for conveying the maximum allowable speed should include an onboard system for HSGGT and should provide enforcement of braking and speed limits.

3. Current Technologies Worldwide

Foreign technologies have established railroad systems and set standards for HSGGT systems not yet introduced in the U.S. Additionally, current aerospace technologies could improve the methods in use in U.S. railroad collision avoidance techniques. There is the potential for these other technologies to be adopted and used in future HSGGT applications in the U.S.

5.2.2 Group 2: Train-Obstruction (Intrusion) Collision Avoidance

1. Introduction

This collision scenario group addresses an HSGGT collision with any obstruction, other than a train, within the guideway area. (Collision with any other vehicle on a guideway system is covered in scenarios 1 and 3.) Collisions in this scenario are predictable and avoidable only to the level deemed practical under current technologies and public acceptance, weighed by cost,

probability and practicality. Obstructions that might be introduced into the guideway in this scenario and possible countermeasures are as follows:

- *Human (or animal) action (trespass, vandalism, etc.)* Human (and animal) action is unpredictable, but predictably so, falling into several areas:
 - Responsible action by design, as with signs, warning devices that do not implicitly prevent easy passage
 - Intentional breach of designed safety, such as driving a vehicle across a guideway with an activated warning system, or trespassing by violating fence or barrier (by human or animal)
 - Unintentional intrusion, as with "human error," which is most often a result of maintenance personnel or equipment fouling the guideway area
 - Vandalism and overt acts to the system, such as placing obstructions upon the guideway, vandalism to guideway, etc.

Human error factors can best be addressed by proper policies requiring high levels of qualifications for responsible individuals, combined with techniques of design that limit the necessity or probability of equipment fouling the guideway. "Safety Zones" can be required, which may include limiting speed where such certain clearance requirements cannot be provided. Design techniques, other than fences and barriers, offer only limited assistance to collision avoidance in this area.

- *"Acts of God" (wind driven obstructions, lightning felled tree, etc.)* "Acts of god" are typically addressed during design of the guideway area, and may require maintenance methods to provide continued probability of acceptable levels. Elevated guideways limit the probability of collision, as do fences, "tubes," and absence of trees and temporary structures (lightweight sheds, etc.) adjacent to the guideway.
- *A technical failure on, or adjacent to the guideway (collapse of adjacent structure, loss of automobile control, non-fail-safe failure of portion of collision avoidance system etc.)*. Technical failures cannot be entirely addressed or avoided. Within an HSGGT system, all potential technical failures under the control of the HSGGT Authority should be addressed and controlled within acceptable levels. Neighboring structures, facilities, and moving vehicles are potential "intruders" in this area. (Joint use of shared right-of-way is addressed in a separate study being performed for FRA.)

Acceptable levels of collision avoidance in this scenario have constantly been upgraded as the impact of intrusion has increased.

2. Current U.S. Methods and Levels

Collisions in this scenario have very limited protection in the U.S. Grade crossing intrusions have been dealt with by public awareness programs, with virtually no change to methods of warning because in the past victims have usually been motorists and rarely train passengers.

Demonstration projects for 4-quadrant gates and active advance warning signs are proposed for funding by FRA. Review of use of traffic signals to supplement these should also be considered.

Trespassers are generally warned by signs and often by chain link fences in high-speed areas. Past vandalism has less impact, however, upon systems that do not rely upon wayside signals (avoiding vandalized signal indications), use microprocessor based systems (gravity drop is not fail-safe when vandalized), and provide high-security devices for preventing unauthorized access. Most types of vandalism cannot be prevented with total certainty.

Often, maintenance crews work on and about the guideways after normal scheduled train operation times, in order to interrupt train operations as little as possible. This practice reduces the possibility that mistakes made by the maintenance workers will cause danger to themselves and to moving trains.

Slide fences are regularly in use as a vital check of the route ahead where rock slides are known to be a threat to train movement. Brush and trees are a constant concern to train movement today, but generally for reasons of visibility and interference with lines, not train movement.

Cattle guard grating successfully prevents passage of livestock (typically, large hooved animals, threatening to a train), though it is seldom used for protection of guideways. Such a method must be considered where high probability of intrusion by such animals exists.

Guideway and grade crossing designs are the foundations for addressing this scenario, with all vital monitoring systems interfacing with the signal system to provide the highest levels of collision avoidance, and minimization of impact. Onboard speed control systems that are provided with constant updating of guideway conditions in advance are required to minimize risk in this scenario.

3. Current Technologies Worldwide

It is standard practice outside of the U.S. to limit speeds at grade crossings, which helps to achieve collision avoidance, but seems to be primarily directed at minimizing collision risk to the train. Many full closure gate systems are in use at grade crossings to prevent drivers from using their judgment. The Swedish National Railway (SJ) has implemented an active warning system that senses the presence of highway vehicles in grade crossings after the gates have closed and alerts the train operator in time to safely brake the train before reaching the crossing. Slide fence technology is also widely employed to check for large objects being dropped on the guideway.

5.2.3 Group 3: Train-Dissimilar Train Collision Avoidance

1. Introduction

This collision scenario group shares all factors with Group 1, but introduces another factor. By definition, all trains in Group 1 share identical technologies to ensure safe passage. The dissimilar train in this area may have significantly different structure and system of operation.

Typically, passage of any guideway vehicle that is not equipped identically with those for which the system was designed is given by means of verbal or written orders, with reliance upon

responsible action by a dispatching authority and the operator of the vehicle. Locations where two non-identical collision avoidance systems intersect can occur at an interlocking or at a non-interlocked switch location.

Presentation of non-interlocked switches is not recommended for an HSGGT system, due to limiting available protection, and will not be discussed here. Adjacent guideways of dissimilar train types and systems may present a threat of encroachment upon the HSGGT guideway due to derailment. Reference 49 presents the results of a detailed study of Shared Right of Way Safety issues for HSGGT systems.

2. Current U.S. Methods and Levels

Collisions in this scenario group are currently protected against in the same manner as found for Group 1. Some authorities have deemed it unsafe to allow mixed passage upon the same guideway and they disallow dissimilar trains sharing the guideway. Additionally, some authorities have established both lateral and vertical separation requirements between dissimilar types of trains to limit encroachment possibilities due to derailment upon one guideway.

For HSGGT systems it is recommended that:

- All intersections of guideways should occur only at interlockings . Maintenance vehicles should be provided with systems that ensure that the overall system effectiveness is not diminished.
- Vertical and lateral separation should be maintained away from all guideway systems relying upon lesser technologies. Separation of dissimilar systems has been addressed, but is not feasible on many existing systems.
- Dissimilar trains should not be admitted to an HSGGT system if their operation can compromise the effective safety of the system.
- Separation of dissimilar guideways operations should be evaluated to provide a "safety zone" if a threat of collision exists.
- Maintenance vehicles that are not equipped with any collision systems protection should not be operated in an HSGGT system during revenue service hours.

3. Current Technologies Worldwide

Generally, this area is separated from Group 1 scenarios by policies and regulations. Current technologies offer little additional protection that is not provided under the Group 1 avoidance techniques.

5.2.4 Group 4: Single Train Collision Avoidance

1. Introduction

This scenario group addresses an HSGGT vehicle colliding with a portion of the guideway system, or overrunning or leaving the guideway system. Adequate train detection, interlocking and guideway integrity, speed conveyance and enforcement, and vehicle and wayside safety systems combine to provide effective collision avoidance.

Guideway integrity and proper speed are two important factors in avoiding a single train collision. In the past, over-speed trains have left the guideway, which had the potentiality for catastrophic collisions. Guideway integrity is monitored by vital systems but typically relies upon maintenance methods and policies to remain effective.

Vehicle integrity is of prime importance, as is having a proper procedure to safely cope with assorted vehicle systems failures, including "runaway track" sections.

2. Current U.S. Methods and Levels

All vital subsystems that provide interlocking, route, and vehicle integrity for Group 1, 2, and 3 scenarios form the basis for protection in this area. Inspection and testing play an important role:

- Guideways are routinely inspected, with a frequency based upon the maximum allowed speed.
- Switches and other movable signal appliances are inspected at a frequency determined by the normal wear associated with the item.
- Virtually all components of vital systems have routine tests and inspections that are designed to prevent a technical failure from allowing a faster than safe speed over the guideway.

The FRA provides regulations and enforcement of all vital apparatus testing and inspection on U.S. railroads. Urban transit systems are not covered by the FRA regulations, but generally follow similar guidelines as a policy. Speed enforcement systems, now in use in many transit systems, also play an important role in this group.

Hot box detectors typically are used to detect axle bearing overheating prior to total failure. This is done by wayside equipment, although on-board equipment should be considered for HSGGT systems. Braking systems are generally monitored only to provide an indication of air available to actuate vehicle brakes, although additional checks will be required on HSGGT systems.

5.3 EVALUATION OF HSGGT SYSTEM REQUIREMENTS

The role of the collision avoidance system is to provide the highest level of safety possible. Within this area two aspects should be considered:

- *Prevention of Collision.* Effective use of state-of-the-art engineering can achieve this goal well within acceptable limits by evaluation of the probability of collision causing factors.
- *Minimizing Collision Impact.* The application of state-of-the-art technologies can meet this requirement by providing the least delay in brake application, and adequate braking levels.

Use of technologies that fail to adequately address probable collision factors should not be accepted in any sub-system of an HSGGT vital system.

To achieve predictable and acceptable safety levels, systems are required to address all possible collision factors -- including layouts, systems and appliances, hardware and software.

System layouts for non-rail-type guideways such as maglev should be upon elevated structures where practical to limit a significant number of threats to system safety. Grade crossing should not be used for maglev systems. The use of a grade crossing on a rail-type HSGGT should also be limited. Decisions should be based on the site limitations that create the necessity for the crossing as opposed to the practicality of a grade-separated crossing.

A centralized control office is well suited to HSGGT operations. It should be capable of monitoring train movements, guideway conditions, and other key functions and alarms . Dispatching decisions and subsequent actions should be completed significantly in advance of train movement towards the affected guideway area.

As train speeds increase, dispatching facilities should manage greater areas at a central location to insure that possible malfunctions of controlled field apparatus have the least negative impact on overall train movement efficiency. Where speeds approach or exceed 290 km/h (180 mph), a fully centralized control location should be in place. Two or more facilities with overlapping jurisdictions should be used as widening of the physical limits makes use of a single office impractical.

The type of signal system implemented in an HSGGT system should communicate changes in conditions quickly to the engineer, control office, and interfacing safety systems. As speeds and braking factors increase, conventional wayside signals become impractical. A signal system that conveys speed controls to the train without constant use of wayside signals offers the ability to achieve a moving block system, which offers several advantages.

- Block lengths can vary, as required, in a moving block system to ensure that an efficient overall system always exists.
- Such a system ensures that any breach of route integrity during train passage is instantly acted upon, which does not guarantee that a collision will not result, but ensures that the lowest possible speed will be attained as soon as possible.

The onboard and wayside systems should be in constant contact with the central control office for both monitoring and control functions in HSGGT systems.

5.4 EVALUATION OF SPECIFIC TECHNOLOGICAL APPROACHES

The various technological approaches, previously discussed, that may be considered for use in engineering an HSGGT collision avoidance system are evaluated below.

Vital systems engineering addresses all the subsystems that will interface to form a well structured collision avoidance system, including civil concerns that form the basis of many vital systems decisions. No single vital subsystem is less important in its role than another, because high-speed systems require more interfacing than most past systems. Communications, intrusion detection, grade crossing engineering and certain vehicle systems must be addressed differently than they were in past systems to provide the level of safety necessary for an HSGGT.

5.4.1 Train Detection, Speed Conveyance and Enforcement

In Chapter 2 the advantages and disadvantages of the variety of technologies for detecting train presence and of the speed conveyance systems are fully delineated. The functions of these areas are combined for HSGGT evaluation because technologies that do not present their capabilities as related functions are not recommended for HSGGT systems.

1. Train Detection Requirements

Real-time vital train detection is the foundation of all vital functions that operate other subsystems. Any failure in this area can be the cause of a collision in any of the four groups of collision scenarios defined previously. Train detection:

- Provides data required to define proper train separation, ultimately preventing Group 1 (HSGGT-HSGGT) and Group 3 (HSGGT-non-HSGGT Train) collisions by supporting the other systems.
- Is required to operate, or prevent the operation of, functions that govern integrity of travel upon the guideway (switches) or across the guideway by others (crossings), functions that are ultimately responsible for prevention of most Group 4 (Single Train) collisions and many falling under Group 2 (HSGGT-Intrusion).

2. Train Detection Summary

Decisions about train detection methods to be used will be made in the following areas:

- *Block-by-Block.* This conventional method identifies a block that a train occupies, as opposed to true real-time methods. Safety effectiveness, headway, and overall performance on an HSGGT requires relatively short blocks.
- *Insulating Rail Joints.* Any type of detection that requires insulating rail joints must be considered impractical for design of new systems. Their effect upon the ride quality and additional maintenance necessitated are discussed in Chapter 2, and their use should be limited to the upgrading of an existing system to HSGGT levels.

- *Microprocessor track circuit.* These types offer additional security from vandals and personnel to what is afforded in a relay based type. They are highly recommended where use is practical. All U.S.-produced microprocessor track circuits currently require insulating rail joints.
- *Audio frequency track circuit.* This highly practical type of detection must include a speed signal conveyance technique, but does not require insulating joints.
- *Transponder.* These systems are also highly practical but very short blocks are required to provide the train with emergency braking capable of stopping the train as quickly as possible to prevent or minimize an impending collision. No guideway integrity check is provided with these systems.
- *Radio-Based.* These systems are highly practical for use on maglev, but they should be complemented with broken rail protection circuits if used on a conventional railroad.
- *Satellite-Based.* These systems have significantly more capabilities than have been used in recent railroad applications. The technology needs to be developed further, however, before application in an HSGGT system.
- *On-Board Radar.* These systems have been addressed, but are not recommended at the current level of progression in such systems.

3. Speed Conveyance and Enforcement Requirements

Preventing or minimizing collisions requires constant communication of maximum safe speed to the train and speed enforcement. Enforcement has typically been supplementary to the operator's actions. A zero speed command for braking must be automatically applied, with the operator supplementing the system actions rather than initiating them. Variations in zero speed types may be used with intelligent braking systems, which are discussed under vehicle systems.

Wayside signals are limited to being complementary on HSGGT systems because speed must be controlled and braking applied as soon as possible. Thus wayside signals are used as location markers as opposed to a true speed conveyance method. The operator could cross-check the speed system by monitoring wayside signals. This cross check would not be a vital, responsible function, but would serve to prevent boredom (similar to highway hypnosis) and make it more probable that the operator could react quickly in an emergency situation.

Cab signals are normally placed in addition to wayside signals to constantly communicate the conditions of the blocks ahead to the operator. They can be an integral part of or an addition to the track circuit in place for train detection. Currently technology allows cab signals to convey speed information required at speeds up to 290 km/h (180 mph) and foreseeably at higher speeds in the future. This requires insulated rail joints and higher power than some alternative systems. Therefore, they are practical for existing systems but may be a poor choice for a new system.

4. Speed Conveyance and Enforcement Summary

- *For upgrading an existing system to HSGGT levels, microprocessor based track circuits with cab signals are a recommended choice. Conventional AC relay track circuits (with cab signals) are also acceptable.*
- *For new HSGGT systems with rail-type guideways, audio frequency track circuits with speed code transmission are the most practical.*
- *For both rail-type and maglev HSGGT systems, radio transmission or transponder systems are practical.*

All systems require onboard speed enforcement with automatic braking when a zero speed is received that warns of high collision probability, and more than one type of zero speed is recommended. (In other words, the reason for the stop signal may be important to convey to the train operator.)

5.4.2 Interlocking, Route and Guideway Integrity

The methods for providing integrity of the guideway and interlocking components are similar to those used for conventional railroads, but there are additional considerations. Limiting all switches to interlocking locations provides the greatest level of integrity. All vital component monitoring (the input to the vital logic processing area) must be provided with fail-safe techniques.

Properly designed, installed, and maintained switches provide a very effective way to reduce the number of safety critical incidents on a high speed system. Positive control and monitoring of switches and associated hardware is essential for safe high speed. The switch detection components should be judged by their effectiveness in preventing single train collisions (Group 4) or derailments.

5.4.3 Vital Logic Processing

Vital logic processing, typically done by relays in the past, can be more effectively accomplished by means of state-of-the-art microprocessor systems. The cost of relays versus microprocessors is not an issue in this study for deciding the comparable value of the two logic processing methods as they should apply to an HSGGT system. The major concern of this study is practical application that fulfills the requirements of a collision avoidance system.

1. Relays

Relay logic should be used for high-speed systems only where current technologies do not provide other more predictable methods, because of the impracticality of providing predictable results in the face of multiple failures and vandalism. (Relay systems have worked well historically, but improved technology should be adopted as it is proven to be safe and reliable).

Relays rely on closed loop circuitry and gravity to provide fail-safe design. Though highly reliable and not prone to faults, fault tolerance cannot be accomplished to any significant degree. Relay-based systems are the current standard, and do provide acceptable levels of fault tolerance and safety using proven design techniques; alteration of their safety levels being generally due to human intervention.

- Conventional relay circuitry by design has two states: on and off. These states cannot be practically checked for vitality beyond the presence of gravity and closed-loop assurance. (Polar circuitry exists, but has not been applied to logic processing circuitry in relay systems.)
- Closed-loop circuitry provides single failure detection, but has unpredictable failure detection on multiple failures. Multiple failure detection of some types would require complex circuitry to provide checks in addition to "on" and "off. "
- Gravity based vitality is susceptible to interference by vandalism and personnel, that should not be accepted on an HSGGT system when other technologies can prevent such interference acceptably.

It should be noted that "plug-in" relays have inhibited many potential non-fail-safe interferences, and any relays required should be of that type.

2. Microprocessor-Based Logic

Microprocessor systems are required for use in systems such as a maglev system that employ vital communications techniques. Microprocessor-based logic employs digital processing (two states of each bit, on and off) that can provide multiple bits associated with all functions and processing in a way that checks the integrity of information received, stored, and processed. Potential failure of any single bit to provide proper information is considerably higher than in relay logic. However, integrity checks and fault tolerance to provide an ultra-reliable (fail-safe and fault-tolerant) logic processing system are limited only by what is found to be adequate for practical requirements of system safety.

- *Redundant vs. Single CPU based systems.* Redundant systems provide true fault tolerance beyond the abilities of single CPU systems, with probability of failure dependent upon system architecture and maintenance techniques. Two types of fault tolerance are available in microprocessor systems:
- *Temporal fault tolerance* is required on single CPU based systems, whereby a fault is clocked with provisions to not shut down if recovery is made within a specified time. Redundant CPU systems may incorporate such functions.
- *Spatial fault tolerance* allows processing to continue in portions of the system and "ignore" data associated with a faulted area. Redundant CPU systems incorporate these functions, though single CPU systems cannot guarantee fail-safe operation with this method.

Many faults associated with current systems are recoverable, though they generally will require a single CPU system to shutdown prior to recovery.

3. Microprocessor Requirements

- Single CPU based systems that do not provide the reliability of redundant systems should not be considered for an HSGGT system where reliable alternatives exist.
- System architecture of a redundant CPU based system should provide the reliability requirements.

5.4.4 Guideway Design

Numerous items must be considered in designing the guideway and wayside interface so as to preclude or reduce the probability of collision. These measures are evaluated in this section.

1. Grade Separation

Grade separation is highly recommended for an HSGGT installation. The most effective way to prevent collisions between HSGGT equipment and non-HSGGT equipment (Group 2 and 3 scenarios) is to keep the two environments physically separated. If other vehicles, people, and animals can be kept out of the HSGGT system, one is left with only having to manage the HSGGT portion - a formidable task in itself.

2. Fences and Barriers

Fences and similar barriers are commonly used to physically restrain people and animals from unauthorized entry into rail systems. While commonly used, these methods do not provide total protection because they can be readily breached by deliberate acts. They do not prevent the unusual occurrence of a wayward motor vehicle from breaching a barrier. Moreover, it is not unusual for fences and barriers to be marginally maintained and therefore more easily breached. A poorly maintained barrier results in gradual and undetected degradation that reduces its overall effectiveness for deterring deliberate acts of trespassing, and accidental wandering into the right-of-way by animals.

Fences are considered necessary for the security of a high speed system, but the integrity of a barrier system must be assured if it is to be effective in minimizing Group 2 and 3 scenarios. Good inspection and maintenance practices are mandatory. A well designed barrier system is expensive to design and install as well as maintain.

5.4.5 Grade Crossing Design

1. Use of Protective Barriers

On an HSGGT system, grade crossings require protective barriers that afford security to the guideway. Current highway-guideway crossing warning systems are not recommended. In an HSGGT system, no grade crossing can allow an individual operating a vehicle a reasonable opportunity to enter the crossing area.

Grade crossings are still used on existing, relatively high-speed rail systems. Indeed, many of the highway deaths in the U.S. which occur at rail grade crossings, occur when highway vehicle drivers fail to act in accordance with warning devices. Grade crossings can be made extremely safe by means of interlocked barrier systems, but maintenance requirements and impact upon highway traffic makes such systems impractical as speeds increase. Use of such systems could close roads for a half hour or more on a two-track system with speeds approaching 320 km/h (200 mph). The long time period is accumulated due to checking for a second train that would require closing the barriers immediately upon opening them.

In instances where grade separation cannot be accomplished in an HSGGT system, the level of protection is directly proportionate to the success of the crossing apparatus installed to limit the judgment of a motorist. Each site must be evaluated individually to assess the practicality and probable effectiveness of the apparatus being considered.

2. Summary

Grade crossings are not recommended in an HSGGT system. They present the single greatest threat of collision beyond the control of safety systems and rely on the proper action of the highway vehicle operator.

5.4.6 Vehicle Systems

1. Wayside Monitors

Railroad vehicles are routinely equipped with headlights, strobe and other forms of flashing lights, audible warning horns and rear end marking devices to alert personnel and the general public of the presence of the HSGGT system. These devices may assist in minimizing Group 1 and Group 3 collisions by alerting both other trains or highway vehicles to the presence of the railroad vehicle.

- *Headlights* are effective in detecting obstruction or track conditions ahead of a train, particularly for conventional operations (Groups 2, 3, and 4 collisions). They should be considered as candidates for inclusion in an HSGGT system, even though their safety value decreases as speeds increase. Their use is a minimization rather than a prevention technique because limits of visibility and braking requirements make them ineffective for collision prevention.
- *Hot Box detectors* are used effectively on conventional railroads where journal bearings are widely used. More sophisticated heat detecting systems can detect small increases in temperature, alerting personnel to the potential for imminent danger. These systems should be considered essential for use on the wayside of a HSGGT system, primarily for prevention of single train (Group 4) collisions.
- *Hot wheel detectors* are similar to the hot box detectors in that they sense an abnormally elevated temperature of a wheel, usually caused by a dragging brake shoe where tread brakes are used. Tread brakes may not be practical on a high speed system. Disk brakes tend to be much more dependable and reliable.

- *Derailment/dragging equipment detectors*, used effectively on conventional railroad and transit systems, can be an added protection against Group 4 scenarios. Good scheduled maintenance practices and safety equipment can accomplish the same purpose without compromising system integrity.

Summary

On an HSGGT system, onboard monitoring has the potential of monitoring additional vehicle items and delivering an alarm or shutdown immediately. Therefore, they are more desirable than wayside monitors for a high speed system.

2. Braking Systems

The braking systems and methods employed should be state-of-the-art on the vehicles in use. A combination of conventional eddy current brake, dynamic brake systems, and friction brake systems should be in use in such a manner that a predictable emergency braking rate is afforded regardless of the failure encountered. The complementary effect of aerodynamic braking systems is not practical in all instances, but where speeds exceed 290 km/h (180 mph) they should be considered for minimization of impact.

5.4.7 Intrusion Protection

Many different kinds of intrusion protection devices have been used with varying degrees of success. These devices include:

- *Signage*, a relatively low cost method of conveying necessary warning and instructional information about the system. Well designed signs with clear messages will improve the overall safety of a system.
- *"Taut wire" system*, in frequent use today, that detects an intruder when a wire strung along the barrier fence is broken. It can be coupled with a train control system to send a zero speed command upon detection of a breach or can simply alert the train of it. These conventional systems are commonly poorly maintained and result in false signals to the point of becoming ineffective.
- *Mercury switches in barrier fence posts* that are wired to send a signal similar to that sent by the taut wire system.
- *Cameras, infrared, ultrasonic, and other related devices* can be used, but at considerable expense to install, monitor, and maintain.

Summary

The need for an encroachment detection system decreases as the distance between the HSGGT system and other transportation systems, either highway vehicles or railroads, is increased. The purpose of existing systems is to detect such vehicle encroachment (primarily Group 3 scenarios) and not normal human trespassers. If safety is optimized by the physical separation of the HSGGT system from other possible encroachers, there would little need for such a system.

5.4.8 End-of-Guideway Design

End-of-guideway measures include previously discussed friction blocks, train stops, and extension of the guideway without power to stop the train. These methods are not effective for high-speed stops; therefore, braking systems must be employed to reduce speed to low speed before these end-of-guideway design features can be employed.

5.5 OTHER CONSIDERATIONS

5.5.1 Reliability

An organized, detailed approach to reliability that begins with design and continues through revenue service should be implemented. The design approaches should include:

- Consideration of the reliabilities needed from a system viewpoint, with allocations to the detailed part level.
- Comparison of the reliabilities needed with the system safety requirements.

1. Component Reliability

This process will identify any products that cannot achieve the reliabilities and determine either the need for design development, component rearrangement, or redundancies.

Some inertia from the supplier industries will have to be overcome, because for years they have been making components that are "good enough." The reliability studies will show, however, that "good enough" is not adequate. Product improvements will need to be made, which will produce a new generation of equipment with no "track record."

An approach to dealing with this dilemma will be to require component burn-in and demonstration tests to achieve mean-life curves with accelerated data. Crucial aspects of these activities include:

- *High intensity failure analyses and corrective actions.*
- *Accountability for failure.*
- *Comprehensive quality control activity with real muscle and accountability directly to the top managers of each company and industry involved.*

2. Subsystem and System Reliability

After component reliability has been achieved, then subsystem and system reliability will need to be accomplished. For some items, a series of qualification tests will be needed to determine their suitability for high-speed applications. Then the traditional acceptance tests, post installation tests, and monitoring during revenue service will occur.

Failure modes and effects analyses will need to be performed to determine the frequency, consequences, and criticality of failures at the component, subsystem, and system level. This effort will expose those elements that would have a potentially detrimental effect on system operations and highlight the need for additional attention to design early in the program.

One of the new problems facing the industry today is failure modes of microprocessors and their software. The ability to predict or even realize that these failure modes exist is a concern to those in the safety field. It is of no less concern to those in the reliability discipline.

5.5.2 Maintainability

Classically, the definition of maintainability is the probability that an item can be recognized as deficient, removed, and replaced, and checked out as having been successfully replaced in a specified period of time. It is usually expressed as MTTR -- Mean Time to Restore. Maintainability analyses will need to be performed on high-speed transportation equipment to determine those items that require excessive time, equipment or personnel for replacement when they fail. This activity, together with the reliability work, will begin to determine the requirements for the maintenance staff and facilities.

5.5.3 Maintenance

HSGGT will produce more demands on maintenance than previous systems -- by type of equipment and quantity of items. If the items that are put in place to achieve safety functions are not periodically checked to see if they are operating properly, then the safety function may not be available when it is needed. Some items will have annunciators to reveal the fact they have failed, but others will be passive and require periodic checks to determine their condition.

For high-speed operations, it is recommended that the entire system be fenced and the fence be maintained. (The general practice for U.S. systems is not to provide fencing except in critical areas.) Drainage and vegetation control will also become more critical for proper track maintenance for high-speed systems.

5.5.4 Training

Certification of qualification for all FRA Hours of Service personnel should be required for an HSGGT system to ensure that personnel whose actions inhibit the collision avoidance system functions are properly trained or experienced. In the past, the personnel in this area have been train operators and signal maintainers. Signal maintainers routinely inhibit safety systems during standard maintenance and testing procedures, and their qualifications and methods for doing such in an HSGGT system should be a requisite part of the policies and regulations that provide safety effectiveness.

5.6 EVALUATION OF SYSTEM PERFORMANCE

The "weakest link of the chain" in an HSGGT system can negate all safety. Therefore, all subsystems that require interfacing with other subsystems must be designed to be equally fail-safe and reliable.

Indeed, all the vital subsystems that provide the required level of safety do interface in a collision avoidance system. Typically, U.S. railroad systems do not measure the level of safety by probability of collision or fatality. Instead they use hindsight statistical approaches based on the past. Although these approaches do not provide safety in the future, they can be used as the basis for developing the probability of level of safety of a future system.

All subsystems and layouts of a proposed system should be evaluated individually to determine:

- *Level of avoidance achieved* -- the probability of effectively preventing a collision.
- *Level of minimization achieved* -- the probability of minimizing impact.
- *Mean time between failures (MTBF) that interrupt system operation* -- based upon theoretical and historical data.
- *Probability of non-fail-safe failure per 1000 hours of operation* -- to include probability of collision due to such failure.

The data for individual subsystems is the input for evaluation of the effectiveness of the system. Safe failures inhibit operations and can introduce new potential causes of collision. It must be assumed that any failure that inhibits the operation of the system as a whole creates risk of collision that can only be dealt with by policy. It is beyond the scope of this volume to attempt to evaluate all the possible policies an authority may have for accomplishing safe movement in such an event.

Generally, the acceptable levels of system effectiveness and integrity are a result of:

- Public acceptance of past records of fatalities per million miles travelled
- The probable degree to which the HSGGT system should exceed past accepted levels

All predictable (and predictably unpredictable) causes of collision can be logically assessed to develop a future collision avoidance system that will meet the safety levels required. The predicted result of any collision of an HSGGT system multiplied by the probable frequency of such events should not result in a product that will exceed any level not already considered acceptable. Use of current technologies, past history, and logical processes enable system designers to exceed all prior safety standards termed acceptable. Future standards will be limited only by economic concerns and public acceptance.

5.6.1 Reliability Estimating Techniques

The U.S. Department of Defense provide DoD standards and handbooks that should be included to complement the FRA and AAR regulations and guidelines. Reliability engineering is best addressed in the DoD standards. Appendix F discusses some important methods for estimation of system reliability that should be adapted to system requirements.

Several procedures or techniques are used for estimating performances of systems from the performance of individual components. Some of these are:

- Mathematical Analysis
- Reliability Logic Block Diagrams
- Reliability Performance Diagrams
- Failure Mode Analyses

5.6.2 System Evaluation

System evaluation consists of two parts: effectiveness in collision avoidance as designed and probability of failure.

1. Effectiveness in Collision Avoidance

Effectiveness of the system, as designed, assumes all components are working as intended and at the mean operating level for which they were designed. Any component operating at a lesser level must be considered as failed. System failure caused by action or inaction of personnel other than as the system provides for is considered a predictable system failure, except in the case of signal maintenance personnel (who have the ability to override all safety systems).

Where historical data is provided, the probability of the following systems performing their intended function must be evaluated:

Braking Systems and Signal Block Layout

100 percent effectiveness in maintaining safe braking distance between trains or to a required stopping point is required with all systems operational as intended. This effectiveness can be evaluated by computer simulation of the signal system layout with all grades, curves, and possible train consists used within the model. The vehicle braking system rates must be input as verified from acceptable theoretical data and/or vehicle testing.

Train Detection and Vital Communications

Depending upon the systems employed, spurious data must be considered as probable during normal functioning. The system must maintain effectiveness, with all systems functioning as intended, at a level approaching 100 percent. Typically, probability of ineffectiveness of $10(-5)$ to $10(-9)$ is acceptable on other vital systems.

Historical data of effectiveness of past systems can be used for most systems, while theoretical effectiveness is required for digital communications techniques. Military specifications that provide methods of theoretical analysis should be adopted for vital railroad communications evaluation. Appendix G presents some current standards used for vitality and reliability evaluation.

Grade Crossing Effectiveness

Only vertical separation affords 100 percent effectiveness, and should be provided where practical.

- *Full, impenetrable barrier closure* that prevents all vehicle entry (locking guardrail type barriers) and includes a system to detect vehicles, animals, or persons within the crossing provides the highest level of effectiveness, approaching 100 percent, and should be considered for a new HSGGT system.
- *Full closure gates (conventional barrier)* provide the next highest level of effectiveness, and should be considered as adequate for upgrading a railroad to HSGGT, with effectiveness only being restricted by inability to limit intentional human interference or intrusion by an out-of-control vehicle.
- *Conventional crossing gates* have limited effectiveness because they offer the motorist the opportunity to judge if they are functioning properly, and to drive around. Effectiveness is a function of the maintenance levels, train speeds, and state of mind of approaching motorists, and results in a low probability of effectiveness; therefore it should not be acceptable.

No other grade crossing options offer enough effectiveness to be considered.

Analysis of collisions at all U.S. grade crossing types on both railroad and transit systems shows high probability of motorists' judgment being responsible for a collision, regardless of warning device used. Acceptability of frequency of probable fatalities must be performed as a site specific study, and anything less than locking guardrail type barrier closure should include reduced train speed. Reduced train speed will lessen crossing closure time and reduce impact speeds, thus providing less opportunity for collision and minimizing threat to train crew and passengers.

Accessibility of Guideway/Right-of-Way

Elevated guideway with well maintained fencing where access is required provides the highest level of effectiveness. A non-elevated guideway with fencing requires vital intrusion detection circuitry and convenient means for animals and persons to traverse the guideway area. Effectiveness of the fence system will be a function of maintenance and circuitry, and site specific logistics of the numbers of people and animals moving in the vicinity, relative to the convenience of the provided means for crossing the guideway. Signs should not be considered effective for HSGGT. Intrusion from determined individuals cannot be prevented, and provision for their personal protection is limited to their actions upon the approach of a train. High visibility lights, supplemented by horns afford an intruder little warning at high speeds, but are the most effective protection when a fence has been breached.

Vandalism

All vital components, systems and appliances should be secured from all but qualified personnel with high security locks, and appropriately secure fastenings and enclosures. Probability of vandalism can be evaluated as a function of site specific data where there is a history of vandalism in the vicinity. In areas of high probability of vandalism, fail-safe electronic relays are preferable to conventional gravity drop relays.

The probability of effectiveness in limiting vandalism will be a product of the guideway placement, past vandalism in the area, and fences and barriers along with intrusion detectors. The effect of vandalism will be proportional to the level of technologies employed and the determinedness of the vandal.

2. Failure and System Effectiveness

Failure can be in two modes, safe and unsafe.

Safe Failures

Safe failures inhibit systems operations and introduce new collision potentials as some portion of the safety systems (or all) must be cut out if train movement is to be made. This introduces human errors that bring an unpredictable probability of collision, but a significantly higher probability than if the safety system were still functioning. Safe failures are due to component fault or failure, vandalism, or proper functioning of the system with an unpredicted entry.

Safe failures should be limited to the extent practicable, as they introduce new risks that are higher than if the failure had not occurred. System effectiveness is unpredictable when safe failures occur, and is dependent upon the subsystems that must be cut out in order to proceed with train movement. The highest level of effectiveness is provided by fault-tolerant techniques that are subsidized with monitoring devices and a maintenance program that provides a high probability of detecting a "first-fault." Electronic components' highest probability of failure exists when the components are relatively new and relatively old. Proper "burn-in" periods limit the probability of "new" component failures when placed in service.

System effectiveness during safe failure can only be assessed by measuring the probable value of policies and regulations that provide the alternatives when a subsystem has failed-safe. The policies to be used in such instances should be compared with past methods and results. All past or future predictably probable collision factors should be evaluated to determine the methods for limiting future impacts.

Unsafe Failures

Unsafe failures, also called wrongside failures, are defined as those failures of the system that provide less protection than would be provided if the failure had not occurred. Any single fault within fail-safe closed loop circuitry will not be unsafe, though additional faults may potentially cause failure. Monitoring, maintenance, and testing must be evaluated to determine the probability of a second fault occurring without being detected prior to its causing an unsafe failure. Electronic systems can provide additional self-monitoring that makes them less likely to incur an undetected wrongside failure than some conventional relay methods. They require dual path processing techniques, however, and should use multiple CPUs for fault-tolerance.

Virtually any wrongside failure of a vital component of the system can be responsible for a collision. Probability of wrongside failures is a function of the technologies employed, effectiveness of self-monitoring, and quality of components. Specifications for components and design should address all predictable component failures to provide a probable wrongside failure level of not greater than 10^{-5} .

System effectiveness during wrongside failures will be seriously impaired, with high probability of a resulting collision. The probable effect of such failure is affected by the complexity of the subsystems, the degree to which adequate specifications in design and manufacture are met, the limits set to human intervention in the subsystems, and monitoring methods employed to detect inappropriate operations.

Probability of failure should be addressed for all vital systems to provide an overall level of system effectiveness in preventing or minimizing collisions. Every subsystem discussed within this volume should be measured against historical or theoretical benchmarks to evaluate:

- Ability to perform intended functions
- Component reliability
- Component fail-safe effectiveness
- Resistance to threat of vandalism
- Resistance to tampering by unauthorized personnel
- Operational tolerance of component failure
- Maintainability of subsystem

The first two items listed may rely on monitoring, maintaining, and testing of system components. If the system fails to meet an accepted maintainability level, such a system has the potential to degrade to unacceptable levels.

Specifications for all system components should include reliability levels for all components and provide the evaluation benchmarks.

The HSGGT Collision Avoidance System Effectiveness will be determined by the degree to which:

- All subsystems meet benchmarks of acceptable levels of past or theoretical future performance.
- Overall system design incorporates techniques that meet all previous requirements.
- System design exceeds all previous requirements that address time-, speed-, and distance-related safety factors by an exponential factor of the higher speed.

Collision force increases as speed increases. Therefore, effectiveness in preventing or minimizing a collision or its effects requires a decrease in probable system failure to provide protective level equal to that currently provided.

With all benchmarks and previous requirements met or exceeded by the appropriate factor, and all predictable factors adequately addressed, system effectiveness can be calculated. All current state-of-the-art methods and all predictable (and probable) risks must be provided for, or the benchmarks derived from past experience and the lessons learned cannot serve as a basis for the future system.

- Avoidance effectiveness is measured by the probability of collision per number of passenger-miles travelled.

- Minimization effectiveness is measured by the probable injuries and fatalities per passenger-miles travelled.

These two items will present the risk to the train, its passengers and crew, and separately to the public at large. Risk is defined as the probability of occurrence multiplied by the level of harm.

Historical data provides risk factors by hindsight mathematic calculation. Traditionally, forethought calculations of acceptable risk of injury and death are not presented to measure system practicality and safety. It should be assumed that the presentation of such for planning a system will require meeting or exceeding previously acceptable risk levels in order to meet public acceptance and litigious responsibilities.

APPENDIX A. HISTORY OF COLLISION AVOIDANCE

An exploration of railroad history reveals that high speed was immediately achieved in 1825 (relatively speaking), but technologies for collision avoidance lagged behind by nearly 100 years. In the U.S., trains have not significantly increased in speed, nor have significant advances been made in collision avoidance techniques since 1951. During the first hundred years collision avoidance techniques were developed by hindsight, but current logical processes and technologies now allow us to develop future collision avoidance for an HSGGT system without such potentially catastrophic "trial- and-error" processes.

The Birth of Collision Avoidance Techniques

The advent of the steam locomotive upon a dedicated right-of-way did not bring with it the technologies required to provide collision avoidance beyond line-of-sight reaction abilities, braking systems that could barely be called adequate. Prior to 1844, and the introduction of the telegraph, train separation was most often accomplished by strict adherence to timetables, with hand lanterns or flags being walked by employees to provide protection outside of timetable travel. One early system used line of sight and a ball that could be raised or lowered. The authority to move was signaled by the sight of the raised ball. This became known as the "High Ball" - a term still used in railroad jargon for the movement of a train.

Further developments increased productivity and safety. The widespread use of train detection by observation created safer systems than previously possible as railroads adopted telegraph use. The first electric track circuits to provide train detection were introduced in 1872, with automatic block signaling being introduced the same year. Interlocking integrity through checking of switches and drawbridges was not introduced widely until the 1900's, after numerous accidents had occurred.

Interlockings

Mechanical interlockings used levers that operated pipe lines to control and move switch points, including point lock and detection bars that had to be raised above the rail to test for train wheels before a route change could be made. This feature is still used and is referred to today as detector locking. The pipe lines also controlled semaphore arms, the earlier forms of interlocking signals. The interlocking bed was designed to ensure that a route to be cleared through the interlocking did not conflict with or oppose any previously cleared route. With the advent of track circuits, further safety improvements were added to the signal system that prevented changing a route while a train was approaching the interlocking.

Early traffic direction control was augmented by a series of train order stations, placed at strategic locations along the railroad. The dispatcher was in command of the system and passed orders on to the operators located at the train order station. The operator was in control of a train order signal. The train approaching one of the locations could receive a clear (vertical) board, indicating route authority with no change to its written order previously received, while an approach (45⁰) board indicated route authority but with a change to previously received orders. A horizontal board indicated that the train must stop and not enter the next block.

Improvements in Technology

The mechanical interlockings were later replaced by electro-mechanical interlockings. The pipelines were replaced with wires and vital relays. The vital relays were developed to provide the same integrity as the mechanical interlocking beds. Carbon contacts were used so that contacts would not be welded together.

The high speed of 24 km/h (15 mph) was eventually accepted, then 80 km/h (50 mph), then the very high speed of 160 km/h (100 mph) was introduced by 1950 as signal systems and braking devices were developed that made such travel relatively safe. The success of the automobile introduced new threats to public safety as grade crossings became necessary. Public realization of the life threatening confrontation was limited, but, even with the inability of the general public to judge a train's closing speed upon a grade crossing for many years, very little was done to promote safe passage to the motoring public.

More advanced systems came into being as a result of electric control. Remote control that allowed the operator (dispatcher) to control the movement of trains over large areas of the system became possible. ATP type signaling by means of train stops that activated the brakes if the train operator disregarded a stop signal began in 1880, while the mechanical stop typically used today was invented in 1901, and became widely accepted for transit use by 1909. Intrusion detectors that set signals to stop were being used by 1922 to prevent collisions because of rock slides, along with the use of slide fences. Further safety measures were introduced in the 1920's, with 1925 seeing the first "cab-no-wayside" signaling, as cab signals came of age to complement the system at the same time that inductive train stops were introduced.

This technological level of 1925 for collision avoidance is the current level in use today on most railroad systems, though many components have been updated with newer hardware. This level has provided performance satisfactory to the public at speeds exceeding 160 km/h (100 mph) since 1930. Freight trains have typically not been equipped for ATP, as immediate braking by applying full brake pressure can produce catastrophic results. Locomotive Speed Limiting (LSL) was introduced aboard freight trains in 1990, and mandated to those sharing the Northeast Corridor with passenger trains, following a high-speed collision between an Amtrak passenger train and a Conrail train of freight locomotives that had ignored a stop signal in Chase, Maryland.

Few significant innovations in collision avoidance systems have occurred since approximately 1951, though technologies have improved, and coincidentally, systems have become more reliable and achieved greater effectiveness. Most innovations in these systems since 1951 are replacement technologies that provide functions similar to the older methods, but reduce labor or maintenance requirements. Electronic circuits and microprocessor innovations in railroad systems today provide tremendous information processing and speed that has yet to be exercised in developing more advanced collision avoidance techniques. Public safety is constantly being improved, though most often by an expansion of the use of old methods. Today, automatic grade crossing devices are still not in use on most crossings, but many areas now require lamp roundels 50% larger than previously for warning lamps. Electronic systems have allowed crossing warning devices to operate in a more responsible manner to help prevent motorists from choosing to ignore a possibly improperly operating device, resulting in fewer "beat the train" decisions.

Innovations outside of railroad safety have also progressed, and new technologies are now in use outside of the railroad systems that perform suitable functions but have not yet been introduced to railroad systems.

With the use of electronic devices and systems, train movements can now be managed and controlled with the use of satellites. New systems are coming on line that will keep track of every piece of moving equipment and its condition along with expanded wayside detection systems to provide a level of safety and operation not envisioned just a few years ago.

APPENDIX B. THE SELTRAC SYSTEM

SELTRAC train position detection system -- a transmission based, moving block system -- provides a 6.25 meter resolution. The safe braking distance is based upon civil speed constraints of the line. The SELTRAC moving block control will provide minimum headway with maximum throughput, and precise tracking of the civil speed profile. The SELTRAC system, which has a driverless operational capacity, maintains a vital record in its database of the length of each entered train and prevents trains from entering tracks which are not long enough.

The onboard control continually monitors train speed, comparing the actual train speed with the civil speed limit, the braking curve and any temporary speed restrictions that may be in effect. When overspeed is detected, an immediate emergency brake is applied on board the train and it is brought to a safe stop. In traditional American train control systems, the vitality is achieved with vital logic located adjacent to the track, and the office serves as a non-vital overview control system. In contrast, the SELTRAC system achieves vitality with the central office computer logic which converses directly with each train through a vital communication link. In this manner, the SELTRAC system almost eliminates the vital wayside equipment.

The central office is configured as follows:

- *Operators Interface and Communication SIGNET Ring Subsystem (OICS)*. This central computer system provides the overall non-vital management of the transit system. The OICS is backed up with a hot standby system.
- *Schedule Regulation System (SRS)*. The SRS provides regulation of train movement.
- *Vehicle Control Center (VCC)*. The VCC operates in a 2 out of 3 computer system, and provides vitality to the system. The VCC provides "safe train movements."
- *Solid State Interlocking (SSI)* The SSI provides vital interlocking control, and controls power switch machines.

The OICS and the SRS together provide the functions to enable the central operator, using a workstation (CRTs, keyboards, trackballs) to:

- Initialize/change train schedules, station dwell times, train dispatching
- Implement strategies in the event of emergency or equipment fail
- Reroute vehicles
- Set/change train performance characteristics
- Set routes manually
- Set routes automatically by timetable

- Regulate trains automatically
- Interface to a central overview display board that shows map of track, position of all trains, status of all switch points (normal, reverse)
- Log data
- Use management Information Systems (MIS)
- Track trains
- Interface to passenger information displays
- Interface to public address systems

At the central office, the train supervisor can:

- Remotely adjust the train dwell times to correct for an early or late train.
- Remotely adjust the train acceleration rate or performance level in an effort to provide a corrective strategy.
- Remotely assign a specific braking rate to a specific section of track.
- Add or delete trains, and change schedules to meet realtime needs such as unusual passenger loads or train delays.
- Put into effect or remove temporary speed zones (ATP enforced).
- Define blocking (switch, area) and work zones.
- Issue a command, through a workstation, to initiate an emergency brake application automatically for all ATO and ATP trains. (The system response to the issued brake command is less than or equal to 3 seconds.).

Thus the SELTRAC system vitally assures that the civil speed limit (or temporary speed) is not increased through an error on the part of the train supervisor.

In the event that more than one of the three VCC computers should fail, all trains in the VCC will be brought to a safe stop. Operation will continue and the trains will be operated in manual mode on a line-of-site basis. ATO or ATP trains from a neighboring VCC zone will not be allowed to enter the failed control area. This failure mode is judged to be catastrophic and unacceptable in comparison with the traditional AAR approach. In a system such as MARTA on WMATA, the wayside signal system will continue to function when the office system fails, and an office failure will not affect train movements.

In the event of an inductive loop failure, the VCC will automatically cause the ATO and ATP trains to come to a stop at a safe distance before the failed loop. The train operator will switch to manual mode and operate under line-of-sight rules.

APPENDIX C. U.S. VITAL MICROPROCESSOR INTERLOCKING

The U.S. vital microprocessor interlocking system operates as follows:

- Dual path programming interweaves diagnostic routines and system checks within the operational data base.
- The hardware is made secure by software "loop back" monitoring, wherein the processor toggles the input and output monitor devices, or applies specific check data to the inputs and outputs, and requires a given response from these devices.
- Logic within the microprocessor detects an incorrect response and immediately specifies a fail-safe reaction.
- The diagnostic routines detect safety critical problems within the system and/or improper system operation and take appropriate fail-safe action.

The microprocessor vitally determines that the inputs are read correctly, that the equations are correctly evaluated, and that non-permissive outputs do not become permissive. The watchdog system produces recurring vital clock pulses or a dynamic signal if the results of the diagnostic routines and system checks are determined to be vitally safe. The watchdog clock pulses or dynamic signal is applied to a conditional power supply or vital driver that generates a DC output voltage only when a "correct" input signal is received. The DC output voltage from the conditional power supply or the vital driver energizes a vital cutoff relay (VCR).

The vital outputs require the VCR to be energized prior to allowing energy outputs, using the conventional relay vital method. In the event that the results of the diagnostic routines or system checks determine an unsafe condition, the watchdog clock pulses or dynamic signal stops, the conditional power supply or vital driver produces "0" volts DC output, the VCR drops, power is removed from the vital outputs, and the vital outputs all assume a zero or most restrictive state.

The input terminals associated with each input are isolated from other inputs and are analogous to a separate isolated vital relay coil. The output terminals associated with each output are isolated from other outputs and are analogous to relay contacts. The vital I/O circuitry achieves the same safety and isolation as a vital relay contact.

Isolation is achieved by maintaining physical separation between printed circuit board traces and connections, and by using opto-isolators and magnetic devices which have isolation levels which meet or exceed AAR requirements. The speed of system operation and communication is such that the total communication and processing time for a vital reaction to change in field inputs does not exceed one second.

These microprocessor systems are equipped with two or more vital I/O serial data ports compatible with EIA standards RS232C and/or RS422. The vital serial link is used to vitally couple two or more vital microprocessors. The vital data link continuously refreshes, and re-

communicates all data between vital microprocessors, whether or not if I/O has changed. The serial data protocol is configured to include security information such as cyclic redundancy code bytes that provide an acceptable level of probability of security.

APPENDIX D. SOFTWARE APPLICATION IN THE UNITED STATES

The steps in the application process are as follows:

- Interlocking logic design is defined in terms of traditional relay logic and is converted to Boolean algebraic expressions.
- The Boolean algebraic expressions are then submitted to a high-level compiler which converts Boolean algebra to machine language or applicable code that resides in Erasable Programmable Read Only Memory (EPROM).
- The EPROMs are inserted into the vital microprocessor.
- The vital microprocessor executes the application code and performs vital interlocking responsibilities.

The executive and application programming are installed in a non-volatile memory in such a way as to preclude unintentional changes by the user. The high level compiler uses "AND," "OR," "NOT," and "XOR" (exclusive "OR") functions. The software has the capability of defining functions equivalent to relay slow release, slow pickup, or slow release and slow pickup. Time delays are programmable, are at least from 1 second to 30 minutes, and are individually programmed.

Inputs, outputs, and internal relay equivalents are defined in software using alphanumeric names of up to 12 characters.

Application software is organized as follows:

- Software defined system control statements
- Software defined system indication statements
- Vital input and output definition statements
- Vital serial communication input and output definition statements
- Nonvital input and output definition statements
- Nonvital serial communication input and output definition statements
- Internal relay equivalent definition statements
- Time delay and flashing/coding definition statements
- Application logic statements

The high-level compiler performs code generation and assembling functions. The code generation function includes syntax analysis and semantic analysis. Syntax analysis looks for improper grammar in the program. Semantic analysis looks for meaningful statements. The source program is processed and is converted to application code. The assembler converts the application code to a format that can be processed by the EPROM Programmer. The simulator works in conjunction with the compiler and allows testing of a completed program prior to actual loading in the system hardware. The simulator executes logic using the same algorithm as the run-time system. Commands are provided in the simulator to mimic operating aspects of the

designed system. Commands include setting and clearing internal and external logic relays, and advancing system time. Logic statements and the system clock are stepped individually or simultaneously at any desired increment. The simulator provides commands which display:

- Inputs and outputs as physically arranged in the I/O card file
- Names, bit numbers, and status of individually defined relays
- Logic statements as they are executed

APPENDIX E. TRAIN BRAKE INSPECTION AND TESTING

Daily Inspections

- Check of the braking system, control stand, lighting, HVAC, windows, windshields, walkways, steps, handrails, radios, PA, and other safety related systems/components
- Braking and train control testing (departure testing required both by the FRA and UIC) performed by the maintenance and operating crew at the start of each trip/shift. (Many accidents have occurred due to this testing either not being done properly or not being done at all)
- Filling out of daily report forms by the inspector and also by the operators, who note any discrepancies found during their trip/shift
- Cleaning of cars

Periodic Inspections

These more detailed ninety-two day inspections, done over an inspection pit that may be in a maintenance shop, include:

- Testing and certification of air gages
- Inspection and testing of all automatic controls, protective devices, and alarms
- Checking of lubricants in gearboxes, journal bearings (if not sealed, grease lubricated), and other moving components, and filling to the proper level
- Visual inspection and cleaning of all electrical components and visible insulation
- Thorough cleaning, inspection and testing for continuity of all electrical jumper cables of more than 600 volts
- Repair or replacement of a number of carbody, electrical, and mechanical components, as required

Annual Tests

- Changing brake/pneumatic system air filters, brake control valves, and electric meters
- Testing and the periodic inspection of all of these systems, as described above
- Additional maintenance with the specifics dependent upon the different types of systems on the vehicle

- Removal, cleaning, testing and certifying of brake control valves, gages, meters and other electrical devices, which are typically returned to stores for replacements parts

Biennial Tests

- Annual and periodic inspection tests and maintenance
- Changing of additional brake control valves, brake actuators, and master controllers
- Hydrostatic testing of air reservoirs
- Additional maintenance depending upon the design of system components

APPENDIX F. SYSTEM PERFORMANCE ESTIMATING TECHNIQUES

There are several procedures or techniques for estimating performances of systems from the performance of individual components. These techniques assume that the data for the failure rates of the components is known, generally from empirical data. Some of these are:

- Mathematical Analysis
- Reliability Logic Block Diagrams
- Reliability Performance Diagrams
- Failure Mode Analyses

The most accepted form of mathematical analysis is the failure rate summation analysis where the reciprocal of the summation of the failure rates is the mean time between failure MTBF. This becomes the System MTBF. For series type systems, this becomes a simple addition of failure rates. For more complex systems, a variety of mathematical equations can be used to describe the functional relationship of the components, eventually converting them to a series function and then completing the addition. An example is described below:

- Component A - failure rate $(\ddot{e})_1 = 100 \times 10^{-6}/\text{hr.}$
- Component B - failure rate $(\ddot{e})_2 = 50 \times 10^{-6}/\text{hr.}$
- Component C - failure rate $(\ddot{e})_3 = 30 \times 10^{-6}/\text{hr.}$

$$\sum_{i=1}^3 \ddot{e}_i = 180 \times 10^{-6}/\text{hr. (System Failure Rate)}$$

$$\left[\sum_{i=1}^3 \ddot{e}_i \right]^{-1} = 5,555 \text{ hrs. (System MTBF)}$$

This technique reveals that three components, arranged in series with instantaneous failure rates of $100 \times 10^{-6}/\text{hr}$, 50×10^{-6} , and 30×10^{-6} will yield a system MTBF of 5,555 hrs. This technique operates on the premise that the components exist in the constant failure region of the reliability curve illustrated below:

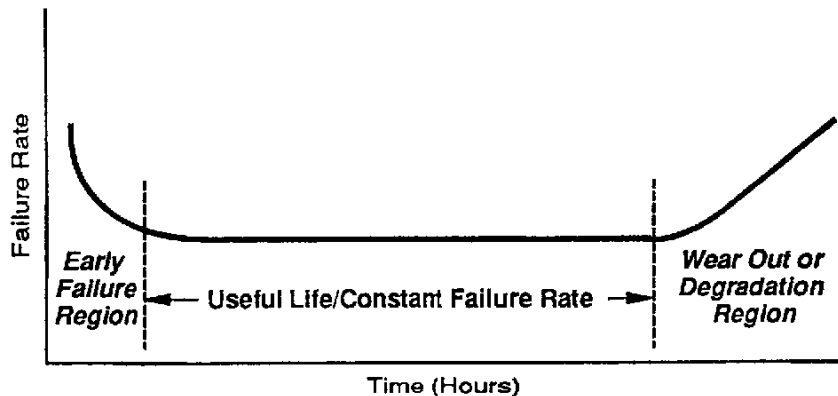

One of the foremost professors and lectures of the subject of reliability, Igor Bagovsky, in his book Reliability Theory and Practice, has given us an extremely useful equation for the relationship between useful life, reliability performance, and mean time between failure. The differential equation is expressed as follows:

$$R=e^{-T_0/MTBF}$$

where:

R = the expression of probability of success, survival, or failure free operation - generally identified as .95 to .99

e = the base of the natural logarithms

To = useful life, design life, time between overhaul, or other operating parameters

MTBF = Mean Time Between Failure

This equation becomes valuable when two of the parameters are known and the third is needed. Many firms have used this equation to determine the design of components for MTBF when the Reliability and Service Life is specified by customers. It can also be used to evaluate systems, and to determine the performance values for components as well as the system. In some cases it has pinpointed the need for redundancy. In other cases, it has determined the maintenance necessary to produce the probability of success when the MTBF's cannot be improved.

Reliability Logic Block Diagrams are a useful tool to evaluate system arrangements. The diagram can be constructed to reveal the functional relationships between components in a system. An example is shown below.

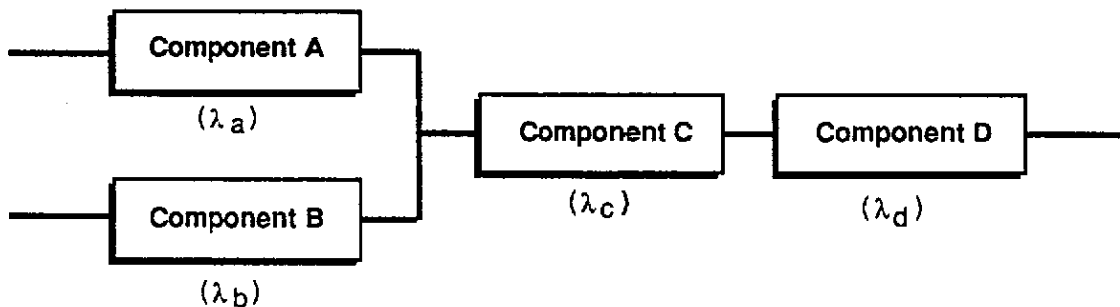

Once these diagrams are constructed, the lambda (λ) or failure rate can be assigned to each block and by the nature of the relationship (series, or parallel, or otherwise), a mathematical expression can be developed to determine overall system performance. Scrutiny of this diagram can produce real insights into the design and systems arrangements. A valuable product of this effort is the ability to match failure rates with single-point failures, revealing system vulnerability.

Reliability Performance Diagrams are the same as System Performance Diagrams except that they contain the lambda (X) data which enables them to be used to calculate the probability of producing a system function as shown below.

The particular value of these Diagrams is the ability to predict the time-dependent variables for system performance where rapid transfer of information is necessary for 480 km/h (300 mph) operations.

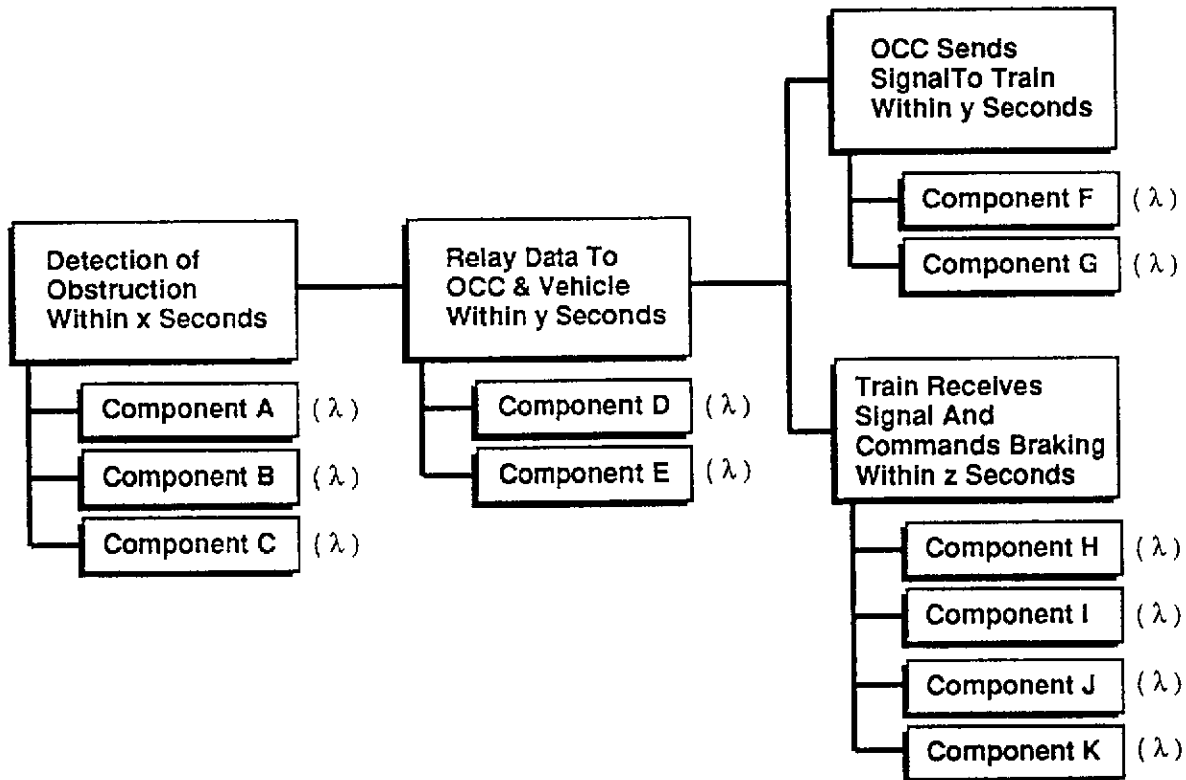

Some existing rail equipment will show excellent failure rates for 85 km/h (55 mph) operation but will need to be carefully examined for application to 480 km/h (300 mph) operations.

Failure mode analyses are another tool for examining the performance of components and their application to HSGGT systems. Since components generally have more than one failure mode, the consequence of each failure mode needs to be evaluated by its effect on the system. This should begin at a component level, proceed to the subsystem level, and then to the system level. Single point failures that progress to the system level should be eliminated. A particular value of this analysis is the apportionment of the failure rate for each failure mode of the item. In this manner, the probability of undesirable effects on the system can be forecast or predicted. In the mathematical analyses these are known as "Service" failures and when considered by themselves, become the system MTBSF.

At this point in a reliability analysis, it is always good to compose the Safety Fault Tree Analysis with the Reliability Failure Mode and Effects Analyses because the Safety analyses represent a top-down approach and the Reliability analyses represent a bottom-up approach. If either approach reveals conditions that are not considered by the other, appropriate adjustments can be made. This comparison provides a measure of comfort in that all conditions have been considered.

The concept of Fail-Operational/Fail-Safe should be considered at this point. The concept in itself is fairly simple. Critical items should be allowed to fail with an annunciation and a time condition, but the system will safely operate, even if in degraded mode. If the second failure occurs before the first one can be corrected, the system will react in a safe manner, even if that means a system shutdown.

System Response is a critical parameter in the evaluation of any component and its performance. Super-safe items that cause frequent system shutdowns can actually create unsafe operating conditions. In addition, the reaction of system operators to these kinds of problems is to disconnect the circuitry or ignore the alarms. Therefore the safety functions that provide alarms must be supplied by very reliable components. These should be identified early in the design phase and singled out for special attention by designers, safety and reliability engineers, and the manufacturers or suppliers of the devices.

The techniques for evaluation of components previously described are dependent upon the collection of data that will describe the basic failure rates of the components involved. This is never an easy process. UMTA sponsored a nationwide effort for several years on rolling stock called the TRIP program - Transit Reliability Information Program. Dynamics Research Corporation of Cambridge, Massachusetts collected data from BART, CTA, GCRTA, NYCTA, PATCO, and WMATA and maintained a national data bank. In 1984, UMTA funding was curtailed and the TRIP program was terminated. However, significant progress was made and the effort was recognized as useful. A similar approach could be considered for HSGGT applications. If this approach is not considered then the conventional methods of data collection will need to be employed:

- A. Visit those properties using train control equipment and examine their maintenance and operating records.
- B. Send out questionnaires - (never very useful).
- C. Request data from component suppliers.
- D. Produce component analyses and predictions.

All of these approaches have their weaknesses but could produce some quantifications for those items that exist and are in use. For new items, reliability analyses as described in MIL-STD-217C will need to be performed, along with appropriate Quality Control parameters during manufacturing and testing.

Reliability Demonstration Testing is another method of evaluating component performance, especially for new or improved items. There are a variety of testing techniques, generally following component qualification and acceptance testing. Many criticisms have been made of reliability demonstration tests, generally in the areas of adequate environmental exposures. It is critical that detailed attention be given to any demonstration testing to make sure all performance parameters are exercised in a manner that truly simulates the end-use of the item. Accelerated life testing must be correlated with the intended use of the items and contain a sample size that is statistically significant.

APPENDIX G. U.S. STANDARDS AND SPECIFICATIONS

Mil-Std-785: Reliability Program for Systems and Equipment Development/Production

Mil-M-38510: General Specifications for Micro Electronics

Mil-Std-883: Test Methods and Procedures for Micro Electronics

Mil-Std-756: Reliability Modeling and Prediction

includes: Reliability Prediction: Estimating the Reliability of Each Item in the Above Model

Mil-Std-1629: Procedures for Performing a Failure Mode Effects and Criticality Analysis

Mil-Std-781: Reliability Testing for Engineering Development, Qualifications, and Production

APPENDIX H. BIBLIOGRAPHY

Automatic Train Control in Rail Rapid Transit - United State Congress Office of Technology Assessment.

Bagorsky, Igor, *Reliability Theory and Practice*.

Billington, Lindes Wood, *Power System Reliability Calculations*, MIT Press, Library of Congress No. 73- 2681,1973.

Blanchard, Benjamin, *Maintainability Principles and Practices*, Library of Congress No. 69-12772, McGraw- Hill, 1-69.

Boldyreff, Alexander, *A Systems Engineering Approach to Reliability*, UCLA. 1961.

Bompas-Smith, J.H., *Mechanical Survival*, McGraw- Hill, 1973.

Brignaamo, Mary, and McCullough, Hax, "*The Search for Safety: A History of Railroad Signals and the People Who Made Them*," Commissioned by Union Switch and Signal Division, American Standard, Inc., 1981 on the occasion of its 100th anniversary in the railway signaling industry.

Calabro, *Reliability Principles and Practices*, Library of Congress No. 61-12956, McGraw- Hill, 1961.

Carter, A.D.S., *Mechanical Reliability*, Library of Congress No. 72-5941, John Wiley,

Collision Avoidance & Accident Survivability Volume 1: Collision Threat. Prepared by Arthur D. Little, Inc., October 1992.

Design Reliability Methods Manual, Boeing Co., Report No. D2-3246, 1962.

Design Criteria Manual: Vols. I & II. Prepared for Metropolitan Transit Authority of Harris County, TX 1983.

Elements of Railway Signaling. Pamphlet 1979, published by General Railway Signal.

Enrick, Norbert, *Quality Control and Reliability*, Library of Congress No. 76-54908, Industrial Press, 1976.

Evaluation of Reliability Programs, NASA, Contract No. NASW 1012, SP6501, 1967.

Failure Criteria, Reliability Engineering Data Services, AVCO Corporation, 1962.

Failure Mechanisms, Reliability Engineering Data Services, AVCO Corporation, 1962.

Failure Rates, Reliability Engineering Data Services, AVCO Corporation, 1962.

Gattfried, Paul, *Reliability Prediction Techniques for Flight Control Systems*, Technical Report, AFFDL-TR-67-20, 1967

Handbook of Reliability Engineering, Dept. of the Navy, NAVWEPS 00-65502, 1964

ICE - High Tech on Rail Made in Germany - Special supplements to International Railway Journal and Rapid Transit Review.

Jane's World Railways, 1982-1983, 24th Edition, Jane's Publishing Company Limited, 1982.

Leis, R.D., *The Development of Measures of Service Availability*, UMTA Rept. MA-06-0048-78-3.

Locks, Mitchell O., *Reliability, Maintainability & Availability Assessment*, Library of Congress, No. 73161474, Hayden Book Co., 1973.

Maintainability Design Criteria Handbook, Bureau of Ships, NAVSHIPS - 94324, 1968.

MARTA Technical Provisions, Contract CQ1 10, PBTB, For Train Control, 1975.

Ohki, Tatsuji, *Global Position System Receiver Adopts Palm-Top Format*, JEE, Journal of Electronic Engineering, Dempa Publications, Inc., Tokyo, Japan, November 1991.

Railway Control Systems. Compiled by a Project Group of the Institution of Railway Signal Engineers under the general editorship of Maurice Leach.

Reliability Prediction of Electrical Equipment, MIL-STD- 217C, 1979.

Reliability Control in Aerospace Equipment Development, Society of Automotive Engineers, 1963.

Reliability Design Handbook, Bureau of Ships, Contract No. bSR-87433, NANSHIPS 594501, 1963.

Reliability Design Handbook, RADC-GAFB NY, RDH-376.

"Reliability vs. Design," *Machine Design*, 1968.

Russell, D.F., and Williams, A.J., "The Design and Development of a Brake Disc for High Speed Trains," *Proceedings of the Institute of Mechanical Engineers*, Volume 204, 1990.

Safety Relevant Observations on the TGV High Speed Train, USDOT, July 1991.

Safety of High Speed Guided Ground Transportation Systems; Shared Right of Way Safety Issues, DOT/FRA/ORD-92/13, 1992.

Safety Relevant Observations on the ICE High Speed Train, USDOT, July 1991.

Safety Relevant Observations on the X2000 Tilting Train, USDOT, March 1991.

Sporleder, H., *Continuous Automatic Train Control and Cabin Signalling with the LZB 80*, Siemens AG, Federal Republic of Germany.

Supplier Reliability Guide, Douglas Aircraft Division, 1968.

"System Effectiveness Quantification Dilemma," *Engineer/Scientist*, 1968.

System Reliability Analysis, R-448U, UMTA DTRS-57-81-C-0084, 1984. PATCO - WMATA Propulsion, Dynamics Research Corporation, Transportation Systems Center,

Techniques of Reliability Analysis, Lockheed Corporation

The Physics of Failure Reliability Engineering Data Services, AVCO Corporation,

Transit Reliability Information Program (TRIP) Reliability Demonstration Plan for Rapid Rail Vehicles, UMTA-MA-06-0060 81-3, DOT-TSC-UMTA-81-49, Dynamics Research Corporation. TSC. 1981.

Veibel, H., *Signalling System for German High-Speed Line*, Standard Elektrik Lorenz AG, Federal Republic of Germany.

Yoseph, R.S., *AWACS Reliability Prediction Procedure*, Boeing Company, 1972.

"20,000 Cars to Get On-Board Devices for Hotbox Detection", *Railway Age*, May 1990.

