

Junior Solar Sprint

Classroom Investigations

*This document was created by:
Andrew Heafitz*

*with the assistance of:
Diane Brancazio
Kevin Otto
Chris Saunders
Ginger Sturcken*

Note to teachers and mentors:

This package of investigations is intended to aid the teacher or mentor in exploring the different components for a model solar car with their students. They are designed to give some background on the topic and discuss the different variables that go into each phenomena. The investigations/demonstrations illustrate the points and help the students optimize their solar cars.

We have made a conscious effort to make their activities as “real engineering world” as possible. They are intended to be fun tools to help students get a grasp of the physical property and to start building up an intuitive sense of the physical world. Even though the answers are sometimes obvious from the questions, it is still important to have the students try as many of the experiments as possible, especially the easier ones which might only take a few minutes, but will give them some hands on experience and give them real feelings for the forces involved. Sometimes the answer is a little counter-intuitive or possibly more dramatic than one would think.

Also included are some commonly known examples which illustrate the principles elegantly. A fun activity is to figure out how these examples really work, or come up with others. The world and nature are full of great examples! Lastly, some of the demonstrations are not only to help design the cars, but also to test, compare and optimize the finished cars in a controlled environment in preparation for the race.

Many thanks to all the 1994 New England Jr Solar Sprint leaders, teachers and mentors whose time and effort went into preparing and testing the investigations presented here.

Transmission Investigation

What is a transmission?

The transmission in a solar car is the part that connects the motor shaft to the wheels or axle. In general, a transmission is any device which transmits mechanical power from one place to another. Power is the product of force x speed (or torque x rotational speed). Transmissions are also used to change the speed and force proportions while transmitting mechanical power.

Some transmissions are very complex, such as a transmission in a car which has several different speeds and shifts between them automatically, and some are very simple, such as the gears in a can opener. A vacuum cleaner has a belt transmission which transmits power from the motor to the beater bar which spins to brush dirt off a rug, and mechanical clock has a transmission to get power from the motor to oscillator to the second hand. Another transmission goes from the second hand to the minute hand. This transmission has a “transmission ratio” of 60 to 1. The second hand goes around 60 times to make the minute hand go around once.

What is a transmission for?

In addition to getting power from one place to another, the transmission can be used to trade speed for torque or torque speed. Hook the motor up to the solar panel or a battery if it is not sunny. The motor spins very fast, doesn't it? Try to stop the shaft with your fingers - not very difficult. If you put the car's drive wheel directly on the motor shaft, it would spin very fast (good) and when you put the car on the ground, the weight of the car would probably be enough to stop the motor (bad). If we believe this motor is powerful enough to move the car, then what's wrong. The problem is the relative proportions of torque and angular speed are not suitable for this application.

The answer to some of these problems is a transmission. The transmission can be a belt, chain, pulley, etc. drive that makes the wheels turn with higher torque (harder to stop), but at a slower speed than the motor shaft. Obviously there is a tradeoff here. High speed but not enough torque and the car won't start or accelerate quickly. Low speed and high torque and the car will accelerate quickly until it reaches its final, low speed. Then it will creep along the track at a snail's pace.

To achieve a satisfactory tradeoff, or compromise, we can build a transmission with a “transmission ratio” that gives the car a medium acceleration and medium top speed. What “medium” is will depend on the rest of the car's design. A formula 1 race car and a farm tractor both have well designed transmissions that allow them to get going and travel at the right speeds. Transmission ratios are also commonly referred to as “gear ratios”. This however is misleading in that it implies that only gears are used in transmissions. Belts, chains and friction drives, etc. are all common transmissions.

Transmission Investigation #1: Effect of transmission ratio

Building a car without any knowledge of the best transmission and ratio is risky because the car will not perform to its full potential (if it moves at all). The following test setup uses a belt and pulley transmission, but the ratio of the pulley diameters applies to all of the other types of transmissions as well (gears, friction drive). Optimizing the transmission ratio in your car is critical for good performance.

Materials:

Motor and 3V power source	Cardboard, foamcore, etc. for chassis
1 small pulley for motor shaft	Rubberband or belt
3 larger pulleys for output shaft (axle)	Hot glue
Shaft bearings	2 shaft axles

Finding Materials:

Search local hardware and craft stores for objects that can serve as pulleys, bearings, axles, etc. Some of the “pulleys” we used included: drawer pulls, videocassette reels, and thread spools. Video cassettes are also great sources of small smooth cylinders that can be used as bearings. Brass tubing (craft stores) or plastic tubing (drinking straws) can also make suitable bearings. You may want to find bearings before you select an axle. Possible axles include wooden rods from hardware stores, wire hangers, and metal or plastic tubing from crafts stores. Note that shafts can be made larger (for mounting wheels, pulleys, etc.) by wrapping tape around the appropriate areas.

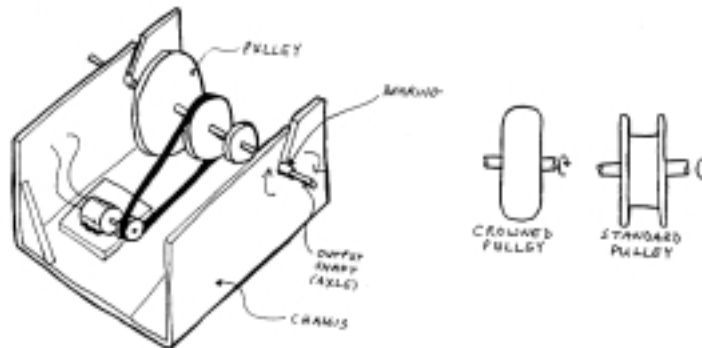

Build a test transmission like the one shown above. Mount the motor on a piece of stiff material (using hot glue, good tape, etc.) that is easy to grip or attach to the chassis. Use it to adjust motor location and belt tension.

Procedure

- Move the belt to different pulleys to see the results of different ratios. See which ratios figure the highest speed, and which make the shaft easiest to stop with your fingers.
- Try different bearings between the axles and the frame.
- Try adding or removing weight from the output shaft to see the effect on acceleration.
- Notice how flat rubber bands tend to crawl up the edges of a pulley - try a “crowned” pulley (convex profile). It’s counter-intuitive, but does work, and is used often in machines.

Transmission Investigation #2: Effect of wheel size

Try different wheel sizes on a sample of cars and see how the performance varies (acceleration and speed). Use a prototype car that you've built or a store-bought toy car. Wheel size is as important a factor in a car's design as the transmission ratio; in fact, they are closely related. Try to calculate what distance your car travels per one revolution of the motor. The transmission ratio will tell you how many revolutions the wheel axles will turn per wheel revolutions.

Materials:

- 1 toy or prototype car
- Lightweight foam tape

Procedure

Experiment with this concept by varying the wheel diameter on your car. If you start with a small wheel, you can build up the diameter with various materials, for example, weather-stripping foam tape.

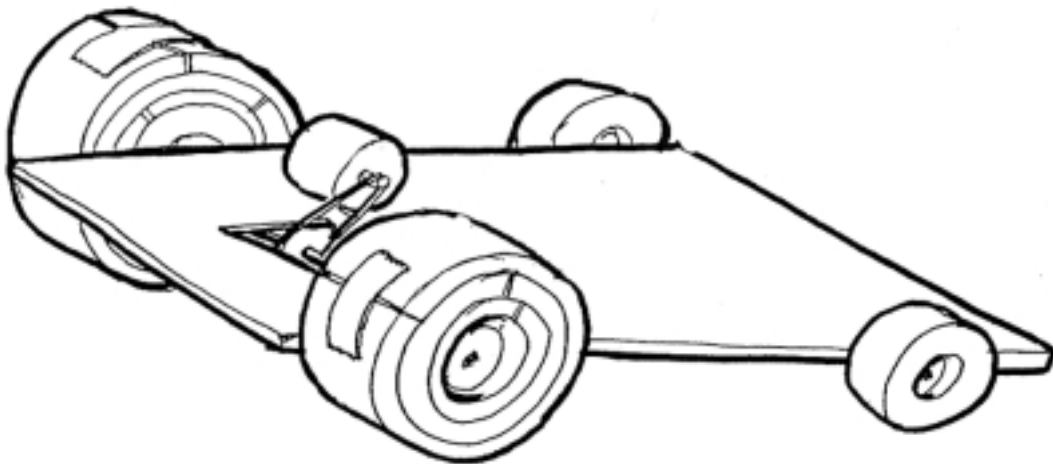

Conclusion

How much larger would the wheels need to be to make the car's top speed be twice as fast? Three times?

How can large wheels hurt the performance of your car?

The two transmission ratios and wheel size combinations shown below will produce cars with similar performance in terms of acceleration and top speed.

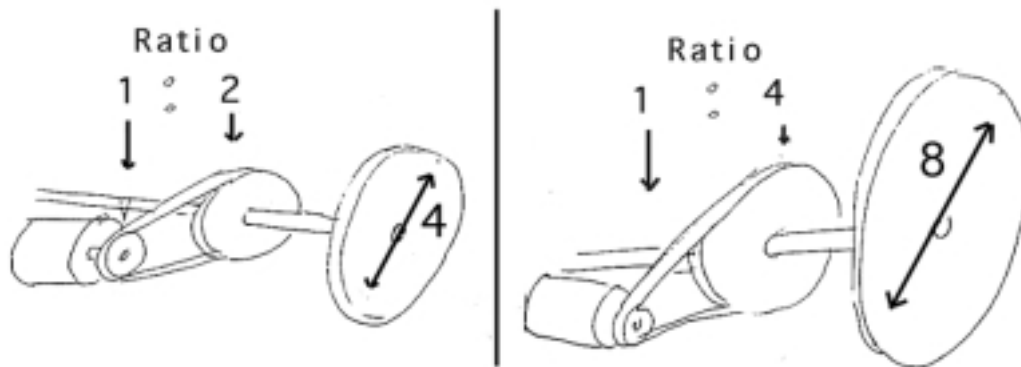

A last note on wheel size, the faster the axle rotates in the bearing the more friction and drag it will have. A larger wheel will allow the axle to rotate more slowly (if the car is to go at the same speed), and will waste less power in the bearings.

In nature, an analogy for wheel size would be leg length. Just as a horse and a hamster will cover different distance if each takes one step per second, cars with large and small wheels will travel different distances with each wheel rotation.

Transmission Investigation #3: Multi speed bicycle

Experiment with a transmission that you're probably already familiar with, a Multi speed bicycle.

Materials

- 1 Multi speed bicycle
- Tape to mark a point on the wheel

Procedure:

1. Take a 10-speed bicycle and flip it upside-down so that it is resting on the seat and handlebars.
2. Hold the bicycle down and start pedaling by hand. (Watch your fingers around the moving parts!)
3. Try several different gears, both on the front gear rings and the back cluster. Each time see how fast you can go and how long it takes to get these from a complete stop.

Transmission Investigation #4: Multi speed bicycle races

A good experiment for students to do at home with their own bicycles:

Materials

- 2 Multi speed bicycles
- 2 students of similar size and physical strength

Procedure

1. Get a friend or classmate and 2 Multi speed bicycles. Put one in the highest gear (small sprocket in front, large sprocket in back) and the other in the lowest. Race to a specified point.

Conclusions

Who got there first?

Expansions

Would the winner be different if the race were longer or shorter? Try it out!

Other examples of transmissions:

A full size car has a transmission with several gears so that you can choose the right ratio for the right time. When you start off, you want a high ratio for high torque and lots of acceleration (first gear). Once you get going, you shift (or the automatic transmission shifts automatically), to a lower ratio for less torque and acceleration, but a higher speed (second, third or fourth gear).

Did you know that a school bus and a sports car both have the same size engine but the transmission gives each of the vehicles its own driving characteristics?

Friction Investigation

Friction is a resisting force between two materials that are in contact and moving past each other, in other words, the sticking force between two objects being rubbed together. In a solar car, the wheels and axles have friction when they turn with respect to the chassis. Minimizing this friction will let the wheels spin more freely as well as faster, resulting in a faster car.

The interface between the axle and the chassis is called the “bearing”. A “plain bearing” can be as simple as an axle in a hole, or it could be a bushing. A bushing is a smooth sleeve in the hole that gives the axle a low friction surface to run on. A “ball bearing” is a set of balls in the hole which are arranged so that the axle rolls on the balls instead of sliding in a sleeve. Ball bearings are found in many familiar devices such as bicycles, rollerblades and skateboard wheels. Ball bearings have the least friction, but they are expensive, and more difficult to use than plain bearings and bushings. For these reasons, most Junior Solar Sprint cars use plain bearings.

Friction Investigation #1: Friction between axles and bearings of various materials

To choose the best materials for axles and bearings (e.g. metal axle in a wood bearing, etc.) find samples of the different materials and test the friction between them. This test will help determine at what angle a sample piece of material starts to slide. The steeper the hill, the more friction there is between the test piece and the material covering the slope. The more friction, the worse those materials are for bearings.

Materials

Plank that can be lifted at one end	Small objects made of various materials
Ruler	Lubricants: oil, graphite, etc.

Procedure

1. Put an object made of the first material on a sheet of the second material.
2. Then, tilt the sheet until the object starts to slide and note the angle of the sheet
3. The lower the friction, the sooner the object will start to slide and the smaller the angle will be. For example, to test metal on wood, put a piece of metal on a plank of wood and tip up the wood until the metal piece moves. Measure the height of the end of the plank so you can compare it to the next sample. One interesting feature of this test is that the weight of the object is not important. A steel paper clip will start sliding at the same angle as a heavy steel object.
4. Try different lubricants and see what happens. Soap, graphite or pencil lead and oil are good to try. Which work best on which materials? Keep in mind that it can be difficult to un-lubricate something if it doesn't work, so test a scrap piece of material using this friction test before lubricating your car if you are not sure.

Picking two materials that “run” well together will mean that less power will be used to overcome the friction and more will go towards driving the car faster.

Friction Investigation #2: Distance of friction force from center of rotation

In addition to the materials that are rubbing together, it makes a difference where they are rubbing. Much like a lever, the farther from the center (fulcrum or pivot) a force is, the more effect it has. It is easier to stop spinning object by grabbing the outside edge than a point near the middle. Therefore, a friction force far from the center slows a spinning object (such as a wheel) more quickly than the same force close to the center.

Materials

- 1 large textbook
- 4 similar coins

Procedure

1. Put the heavy, hard cover book flat on the table. Rotate it slowly back and forth and get a feel for how hard it is to turn.
2. Now, put a stack of about 3 coins on the table under the center of the book and balance the book on the coins. Make sure that the corners of the book don't touch the table and try rotating the book slowly back and forth again.
3. Is the flat book harder to turn because of more surface area in contact with the table? Put a stack of coins under each corner and try the experiment again. Then move all the coins towards the center a little bit at a time and see if it gets easier as they come closer to the middle.

Friction Investigation #3: Rolling resistance test

Use the roll down test described in the “aerodynamics investigation” to find the bearing and wheel combination with the lowest rolling resistance (do not change the aerodynamics of the car during this test because that will also affect the results.) Finding the best combination is an important step in building a fast car.

Materials

- Ramp
- Several prototype cars
 - without motors
 - built using various axle and bearing components
 - approximately the same weight

Procedure

1. Starting from the same point on the ramp each time, let the car roll down the hill and mark the place it rolled to. Do this 3 times for each car, or until the car repeatably rolls to the same place (to make sure you are always starting the cars the same way). Did the cars travel in straight lines? Which car went further? Try improving your car with different axles or bearing materials see how different wheels, bearings, lubricants etc. alter the final distance that the car travels.

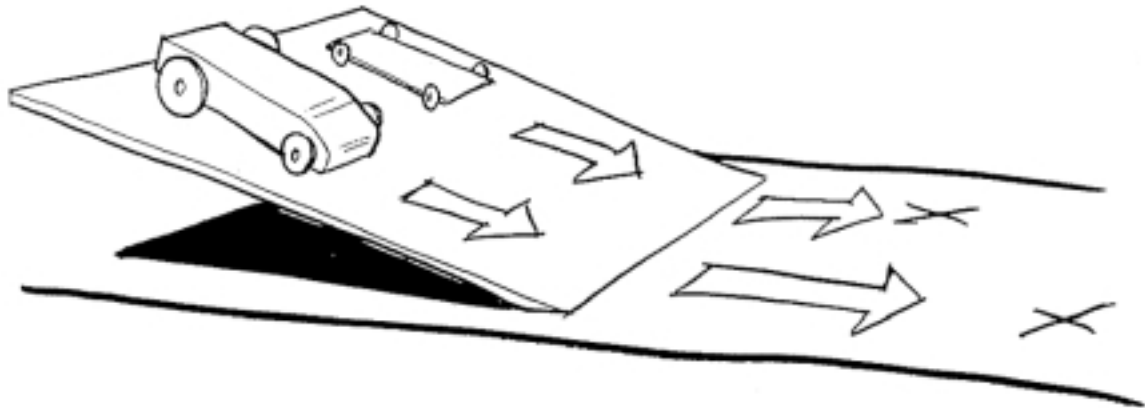

Some places to look for friction in your car design:

Diameter of axle - (is smaller better? Why do “Hot Wheels” toy cars have such tiny axles and go so far?) The larger the diameter of the axle the farther away from the center that contact the bearings. Like the book dragging on the table all the way out at the corners, a large axle will be harder to turn.

Wheel alignment - If the wheels are not all pointing in the same direction, the car will tend to turn. Since the guide wire keeps it going straight, some of the wheels will have to skid sideways. This takes more energy than driving straight and will slow the car down.

Axle bearings - Choose axle and bushing materials that have low friction against each other. Surface finish is critical. Make sure all of the running surfaces are as smooth as possible.

Thrust bearings - These are whatever keeps the axle from falling out the side of the car. If the edges of the wheels rub on the body, like the book, they will have a lot of drag. If there is something around the axles that let the center portion of the wheel touch first, the drag will be lower, like the book swiveling on the coins.

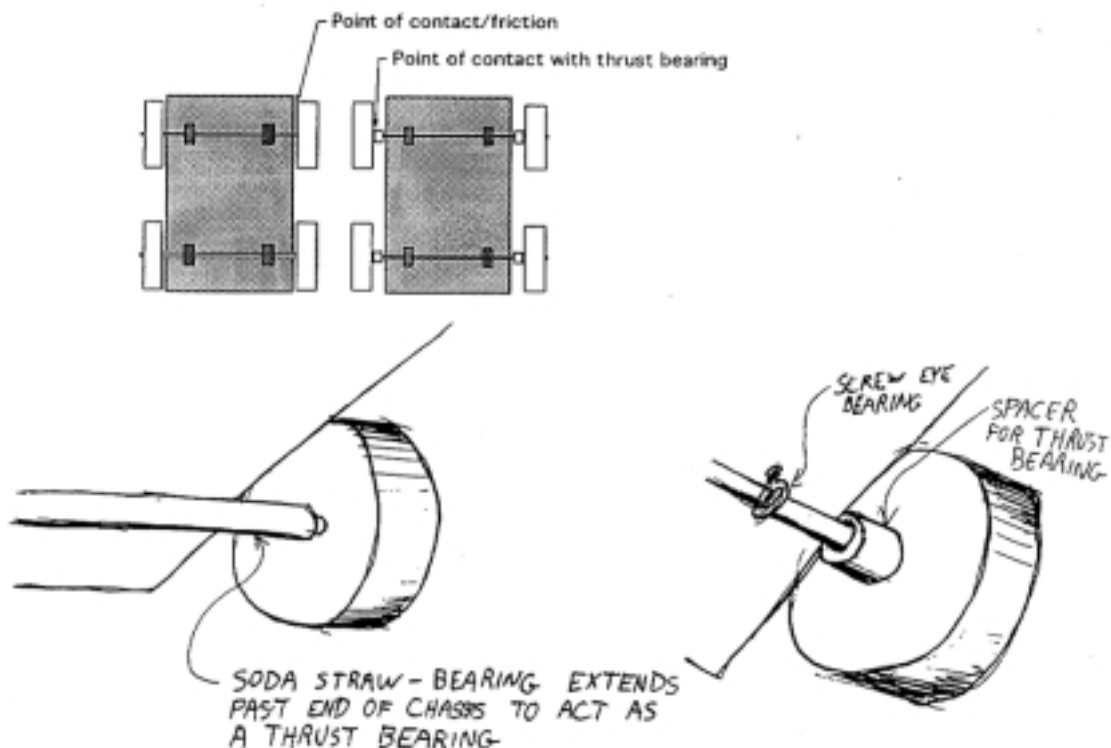

Aerodynamics Investigation

What is aerodynamic drag?

Aerodynamic drag or “wind resistance” is the resisting force that a moving object feels as it moves through air. You probably know that air consists of oxygen, nitrogen, carbon dioxide, and other gases, so it is clear that air does have mass and is not “nothing”. As an object moves through air it will experience a resisting force proportional to the object’s speed and geometry. Since we want our cars to go as fast as possible, let’s look into how to reduce the drag due to the physical dimensions of the car.

There are two primary physical characteristics responsible for aerodynamic drag on a moving vehicle. The first is the “frontal area” of the car, or the cross-sectional size of the car as viewed head on. The second is the shape of the car, or how “streamlined” it is.

Aerodynamics Investigation #1: Nose Cone

Aerodynamic drag can be demonstrated with an ordinary soda can. Since the soda can is lightweight and will slide easily on many hard surfaces, the friction forces on it will be low enough that we look at variations in the resistance from aerodynamic drag. If an object is relatively large and heavy, the friction forces are likely to far outweigh the aerodynamic forces unless the “wind” gets very strong. Most of us are not worried about our family’s car blowing away when sitting in the driveway, but drag is a major factor in fuel efficiency when driving at highway speeds.

We can vary the car’s shape while maintaining it’s frontal area by using different lightweight shapes in the front of the can.

Materials

- Soda can
- Sheet of ordinary paper
- Scotch tape
- Two - ½" diameter wooden dowel rods, 3" long

Procedure

1. Set up the dowels as shown in the diagram and place the soda can on them at one end. Blow on the end of the can and see if it moves.
2. Now make a cone out of paper, and tape it to the front of the can, so it looks like a rocket with a pointed nose cone. Blow on the can with the nose cone again and see if it moves. What kind of resistance forces would this can feel if it were on a moving vehicle? As compared to the flat face can?

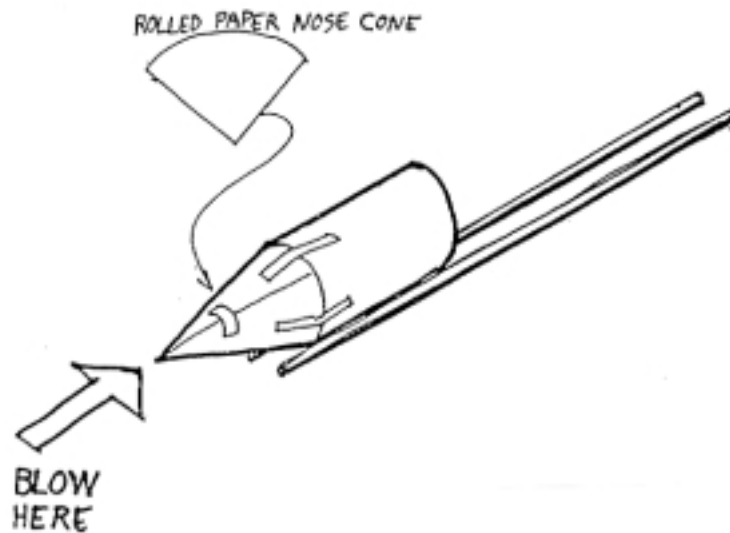

Aerodynamics Investigation #2: Roll down test

Roll-down tests are used by some automobile manufacturers, race car builders, and car testing organizations (among others) to test the aerodynamic drag of a car. The idea is to roll a car (with the engine turned off and out of gear) down a hill, and see how far it rolls. A car with more drag (for example, a car with a parachute behind it) will roll to a stop faster (or after a shorter distance) than a streamlined, low drag car.

Materials

Ramp

One miniature car (a small toy car and track may also work)

Different car profile shapes to put on the car (blocks, streamlined shapes of paper, sheets of foamcore, etc.)

Procedure

1. Set up the ramp and release the car from the top until it repeatably rolls to the same place.
2. Repeat with different frontal areas, keeping the car weight constant. Use one which has a very large frontal area.
3. Try out different streamlined shapes as you did with the nose cone on the soda can. Be careful to keep the other variables constant.

Expansion

Why is it invalid to use different test cars? What other physical properties can affect the amount of distance traveled?

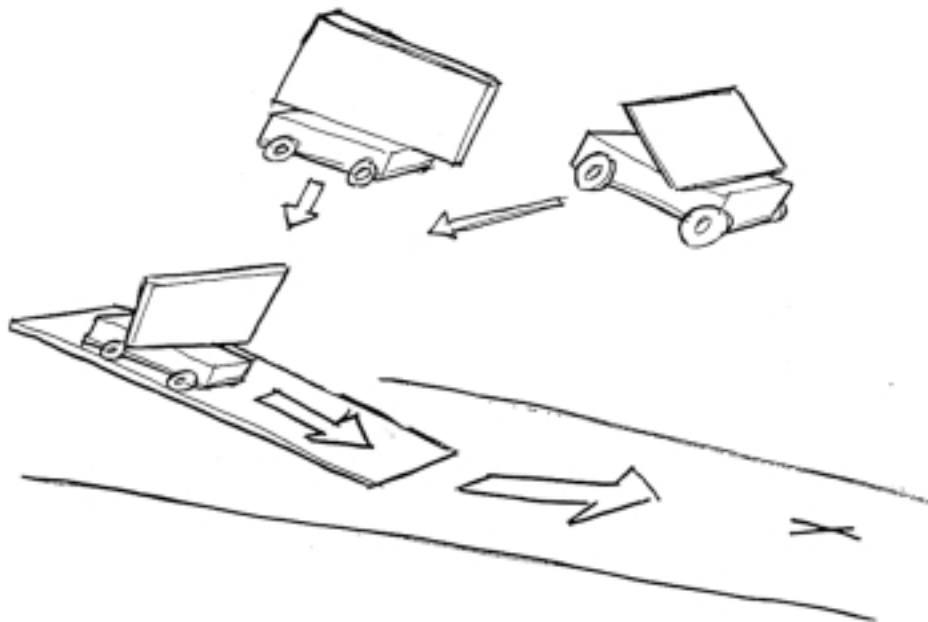

How can you reduce aerodynamic drag in your car?

1. What effect would a streamlined body or nose cone have on the car's top speed and its acceleration? How can you build an aerodynamic shape?
2. The roll-down test is a good tool that can be used to fine-tune the aerodynamics of the final solar car design. Leave enough time to work on the aerodynamics.

Everyday examples of aerodynamic drag:

Aerodynamic drag is considered in many facets of modern life where high speeds are demanded relative to the power source provided.

Semi tractor-trailer trucks now have a "fairing" above the cab to streamline the trailer. Truckers find that the added cost of the fairing is easily offset by the savings in fuel.

When coasting down hill on a bicycle, crouching down reduces the frontal area, and prevents the rider's body from acting like a sail (or parachute).

Birds and fish have streamlined bodies to slip through air or water with minimal effort. Water drag is very similar to aerodynamic drag; the same rules apply, but the effects are seen much sooner in water. (Is it easier to swim through the water headfirst presenting a small frontal area or to walk in chest deep with a large frontal area?)

Airplane and ship profiles are designed to minimize drag as much as is reasonably possible, to increase fuel economy.

Ships have barnacles (clam-like crustaceans which attach themselves to anything solid in the water, including whales and ships) periodically removed from the bottom surface to make them smoother and reduce their drag when moving through the water.

Structure Investigation

A key component of a car is the underlying structure, or the “chassis”. The chassis is a mechanical component that must provide structural support for the motor, wheels, axles, solar panels, etc. When designing a chassis to perform these functions, you may also find you want to make the structure as lightweight as possible (why?). How do we make a chassis that is strong and light? Some materials have a higher “strength to weight ratio” than others. For example, similar weight sheets of paper and plastic will probably not support the same amount of weight. In addition to the inherent strength of a material, its stiffness also plays a major role in the forces that the structure can withstand. We will see in these investigations what the relative strengths of some materials are and how the shape of a material can impact its stiffness.

Structures Investigation #1

The difference in the loads that a miniature car frame can carry with materials of different strength and shape can be demonstrated effectively without building an entire chassis. Here dowel rods are used to simulate axles and wheels, that is, they allow the material to flex and bend much as real wheels and axles would.

Materials

- Two - 1" diameter round dowels. 2' long

- Various size sheet of:

 - Ordinary cardboard 1/16" thick (such as the back of a pad of paper)

 - Corrugated cardboard

 - Foamcore board

 - Balsa sheet, 1/8", 1/16" thick

 - Plastic sheets

 - Small weights (up to 1 lb.)

Procedure

1. Lay various materials across the dowels and place weights at various positions. Compare how well the materials support the weights. At what position do the weights have the least effect on the shape of the chassis materials?
2. Try two thicknesses of the same materials. Is the extra strength worth the added weight to you? Can you combine materials to achieve satisfactory performance?
3. Vary the shapes of the materials and see how much weight they can support (keep the size and weight of the material constant). What effect does folding have? Does direction matter?
4. Try corrugated cardboard with ribs running the long and short way. Why is corrugated cardboard used more frequently than the same thickness of simple cardboard.

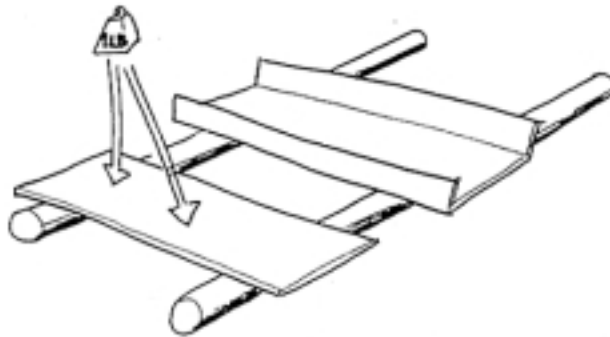

Chassis for model solar cars:

1. What materials (or combinations of materials) would you like to use in a model solar car? Are there any other materials you would consider but didn't have today?
2. Composite structures, made from multiple materials, can be designed to have high stiffness to weight ratios that are much higher than those of the component materials themselves. "Foamcore" (foam sandwiched between heavy paper) is one example. Can you think of others?

Everyday Examples

Structural design is a very important part of engineering every commercial product, from machines to clothes. Consider the following examples:

A rubber band is stronger but less stiff than a circular strip of paper of equal width. (Prove it with an experiment).

Bridges and buildings use different shapes to increase the ability to withstand loads from different directions, including weight and wind.

Bridge beams are shaped in cross-section (such as an "I-beam", "channel", or a "box-section") to maximize the stiffness and strength to forecasted loads (such as vertical load against gravity) for a given amount of material. Other cross-sectional shapes are used for different forecasted loading.

Cars and planes use different structural shapes to withstand loads, provide stiffness, and to connect, support and protect different systems (driver, engine, wheels, etc.) into a whole product.

Photovoltaic (Solar Panel) Investigation

The solar panel is the power source for the car. Sunlight strikes the solar cells and the light is converted to electricity on an atomic level. How much electricity is produced is related to the amount of light that the panel collects and how efficiently it can convert the light into electricity.

Your car will have a solar panel mounted somewhere on it. You want the panel to collect as much light as possible, and to convert it as efficiently as possible. The first task is to figure out where to position the panel on the car. The top side is probably best, and nothing should cast a shadow across it.

Trade-off: Tilting panel vs. Fixed panel

The angle of the panel to the sun also makes a difference. Look at the shadow cast by the panel when it is rotated to different angles. The larger the shadow the more light it is catching. However, you may not be able to aim the solar panel directly at the sun with your car design. The position of the sun during the race is unknown (time of day, time of year and racetrack orientation play a role in the sun's position compared to your car). A tiltable solar panel will allow you to adjust your car the day of the race, but at what cost? A tiltable solar panel is harder to build than a fixed panel, it may weight more and cause more aerodynamic drag. These last two will slow your car down. Is a tiltable panel worth all the drawbacks? To answer that question you need to know how much difference the angle of the panel to the sun makes. If you get a lot more power, maybe it is worth the extra effort. If it doesn't seem to make a big difference, spend your time making the car better and faster in other ways.

Panel efficiency

Once the sunlight has hit the panel, the panel converts the energy of the sun to electricity. Does all of the solar energy get converted or does some get reflected and some get turned into heat and lost? A lot of the efficiency of the solar cells has to do with how well they were designed and built. Unfortunately good solar cells are expensive. The solar racing car built by Honda that won the 1993 race across Australia had some of the best cells ever made. A 5 inch x 12 inch panel (like the one in the kit) made of these cells would cost about \$9,000! 200 panels this size allowed the car to average over 50 mph across the entire continent on solar power alone! These cells were almost 25% efficient. That means that 25%, or one quarter, of the sunlight hitting the panels was turned into electricity. Your solar panel is not as good, probably around 10% efficient. However, there are some ways to make your panel as efficient as possible. Keep it clean (dirt and dust will block sunlight like a dirty window). Keep it cool. Solar cells work better when they are not hot. Teams racing full size solar cars will often spray water over the race car's solar panels to keep them cool and running more efficiently when the car is parked and charging its batteries from the sun.

Solar Panel Investigation #1: Power generation

Materials

Solar panel
Motor
Voltage and/or current meter
Sunlight
Lamps

Procedure

1. Hook up the leads of the solar panel to a volt meter (or a motor). Try the following tests to get a feel for how sensitive the solar panel is to different conditions.
2. Vary light level on the solar panel (indoor light, incandescent light bulbs, fluorescent lights, direct sunlight, open shade).
3. Vary angle of panel to sun (watch the size of the panel's shadow change and see how the volt meter changes).
4. Investigate effects of shadows on part or all of panels. What happens if you cover only 1 cell?
5. Investigate how much difference temperature makes. Take a cool panel and quickly place it in the sun. Let the panel warm up in the sun and see if you can detect the difference on the volt meter.
6. Does it matter which way the motor (or volt meter) is hooked up to the solar panel?
7. Put a current meter (ammeter) in series with the motor and solar panel. How does the light level affect the current