

RECLAMATION

Managing Water in the West

High Lakes Stabilization Brown Duck and Island Lakes Technical Memorandum

Uinta Basin Replacement Project



U.S. Department of the Interior
Bureau of Reclamation
Provo Area Office
Provo, Utah

January 2008

High Lakes Stabilization Brown Duck and Island Lakes Technical Memorandum

Uinta Basin Replacement Project

prepared by

Provo Area Office
Upper Colorado Region



U.S. Department of the Interior
Bureau of Reclamation
Provo Area Office
Provo, Utah

January 2008

Concurrence

The undersigned concur with the recommendations identified in this Technical Memorandum. This Technical Memorandum will serve as a Decision Memorandum.

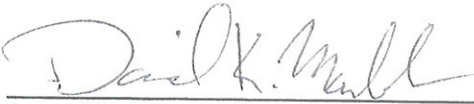

For Jerry Olds, P.E.
Utah State Engineer

5/5/08

Date

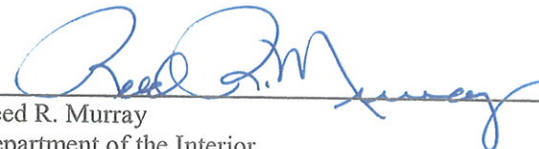

Reed R. Murray
Department of the Interior
CUPCA Office

4/8/08

Date

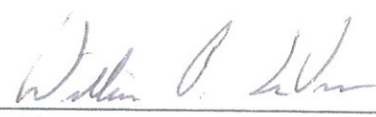

for Harve Forsgren
Regional Forester
U.S. Forest Service

4/25/08

Date



Michael C. Weland
Executive Director
Utah Reclamation Mitigation and Conservation Commission

4/17/08

Date

Contents

	Page
Introduction	1
Design Considerations	4
Island Lake	5
Inflow Hydrology.....	5
Dam Break Analysis	6
Outlet Works.....	6
Outlet Channel	7
Brown Duck Lake	8
Inflow Hydrology.....	8
Dam Break Analysis	9
Outlet Works.....	9
Outlet channel	9
Appendix A - Memorandum of Understanding between State of Utah and U.S. Forest Service	
Appendix B - Drawings	
Appendix C - Inflow Hydrology Output Files	
Appendix D – Construction Quantities	
Appendix E – Dam Break Output Files	
Appendix F - Historical Drawings	

Introduction

The Uinta Basin Replacement Project (UBRP Project) was authorized by Section 203 of the Central Utah Project Completion Act [CUPCA: Titles II through VI of P.L. 102-575, as amended]. The UBRP Project is located in Duchesne County near the towns of Altamont, Upalco, and Roosevelt, within the Uinta Basin of northeastern Utah. Its purposes are to increase efficiency, enhance beneficial uses, and achieve greater water conservation within the Uinta Basin. The Central Utah Water Conservancy District (District) is implementing the water development portions of the UBRP Project, and the Utah Reclamation Mitigation and Conservation Commission (Commission) is responsible for mitigating project impacts to fish, wildlife and wetland habitats. Funding for mitigation measures is provided under Title II of CUPCA through the U.S. Department of the Interior. The Final Environmental Assessment for the UBRP Project was prepared by the District and was signed by the Department of the Interior in October 2001. Project construction began in 2003. The Commission issued a Decision Notice and Finding of No Significant Impact in February 2004 for implementing fish and wildlife mitigation features of the UBRP Project.

A component of the UBRP Project is that thirteen high mountain lakes formerly used to store water rights would be stabilized at No-Hazard levels, and the water rights transferred downstream for storage in the enlarged Big Sand Wash Reservoir, another feature of the UBRP Project. The stabilization of the thirteen reservoirs is mitigation for the enlargement of Big Sand Wash Reservoir. Because of the breach potential of the High Lakes Dams, and the difficulty in monitoring and maintaining these dams in the Wilderness area, the CUP Mitigation Commission is undertaking the stabilization of thirteen of these dam structures and replacing the storage water rights downstream in the expanded Big Sand Wash dam where maintenance and monitoring is practical. These wilderness dams vary in size, hazard rating and condition and have peak breach flow potential ranging from hundreds to several thousand cubic feet per second (cfs). Breach flows of this magnitude far exceed the carrying capacity of existing streams and they would cause extensive damage to the downstream forest resource, campgrounds, trails, roads, dams and in some cases, private property and residents. The “Do Nothing” option was not considered appropriate because of the eventuality of the deterioration and catastrophic failure of these dams.

There are no absolute criteria for defining a No-Hazard dam. The Utah State Engineer is authorized to make that determination. Section R655-10-5 of The State of Utah Statutes and Administrative Rules for Dam Safety dated July 1996 states “The State Engineer is the ultimate authority on the hazard classification designation for a given dam”. However, the Forest Service also has dam safety responsibilities and the two agencies have outlined a number of protocols regarding dam safety matters in a memorandum of understanding between the two agencies (attached as Appendix A). Therefore, all decisions and recommendations regarding these structures are mutually agreed on by both parties.

Essentially, the No-Hazard rating is achieved by demonstrating that in the event of failure, there is no appreciable damage or adverse affects downstream of the dam. For the more significant structures, this demonstration is accomplished through a dam break analysis. Various stabilized reservoir elevations are assumed and the resulting flood from a sunny day break is compared to the existing downstream channel

capacity. When the reservoir elevation results in a flood that can be contained within the downstream channel, the dam can be considered to be No-Hazard.

Stabilization of the thirteen high mountain lakes at No-Hazard levels will provide constant lake water levels year-round. Nine of these lakes (Bluebell, Drift, Five Point, Superior, Water Lily, Farmers, East Timothy, White Miller, and Deer) are located in the Upper Yellowstone River watershed and four (Brown Duck, Island, Kidney and Clements) are in the Brown Duck Basin of upper Lake Fork watershed. Consequently, streamflows originating in these upper watersheds will return to natural hydrologic runoff patterns, wilderness fishery and recreational values will be restored within the High Uintas, and operation and maintenance impacts will be eliminated in the wilderness area.

The thirteen reservoirs are located in the High Uintas Wilderness Area. The U.S. Forest Service, Moon Lake Water Users Association, U.S. Bureau of Reclamation and Duchesne County Water Conservancy District all have knowledge and experience with operation, maintenance and stabilization of the high mountain lakes. The Commission entered into Interagency Agreement No. 05-AA-UT-1300 with Reclamation to provide engineering, design, construction, and oversight services for the stabilization project. This technical memorandum is a work product under the Interagency Agreement and addresses design criteria needed to achieve "No Hazard" ratings as defined by the State of Utah and as agreed to by the Forest Service, for Island Lake and Brown Duck Lake in Brown Duck Basin.

Typically, the stabilization of these dams will require the excavation of a spillway notch, with stable side slopes, through the middle of the embankment and either removal or plugging of the low level outlet. An armored, stabilized low level channel would then be constructed in the notch to pass normal runoff as well as large storm events without jeopardizing the remaining structure by impounding excess water. In some cases the embankment may be removed or buttressed to decrease the height and increase the stability and ability of the remaining embankment to withstand any seismic event or overtopping during extreme events. This work is the minimum necessary to stabilize these dam structures and restore natural hydrologic flows to the greatest extent possible, while still meeting a "No Hazard" dam safety rating.

The Brown Duck Basin Lakes to be stabilized include Kidney Lake, Island Lake, and Brown Duck Lake. Clements Lake was stabilized in 2007. Kidney Lake Dam was placed under a "Do Not Store" order by the Utah State Engineer in 2006 due to a sinkhole which developed on the upstream face of the dam. Kidney Lake will be stabilized in a future project. Brown Duck and Island Lakes will be stabilized in 2008. The stated objective for these lakes is to create conditions such that any dam, if remaining, is assigned a "No Hazard" classification with a minimum design life of 100 years (essentially a permanent fix). In order to achieve a No-Hazard rating, the stabilized dams and associated reservoir levels must be approved by the State Engineer and concurred with by the Forest Service.

An additional constraint is that each individual dam stabilization project would need to be completed in one construction season (usually July through September) because of the vulnerability of a partially removed embankment. These partially completed dams could easily overtop and fail from snow melt runoff or storms, even if the outlet were still in place and open. Breach flow potential would be extensive even from the reduced lake storage volumes. Existing spillways would be too high to assist in

flood routing under these circumstances and it would be prohibitive to build auxiliary or temporary spillways over the excavated embankment or on bedrock at the proper level, even if it could be located.

Multi-year construction projects to stabilize a single dam have serious potential problems, including:

- Increased vulnerability to failure from hydraulic overloading when partial breaches may not be adequately stabilized;
- High potential for erosion and soil disruption from over-wintering and unexpected weather events;
- Additional required work and disturbance to reconstruct and stabilize the dam at the end of each construction season
- Increased mobilization and demobilization costs from additional work cycles;
- Increased site disturbance from multi-year operations at camps, travel routes, and activity on-site;
- The U.S. Forest Service does not allow riprap spillways on moderate-hazard earth fill dams; therefore any intermediate “spillway” or outlet channel on a partially stabilized dam would be required to be hardened, probably with concrete;
- High potential for unexpected, early adverse weather conditions which could close the construction project prior to adequate stabilization.

In addition, because these dams were constructed at the turn of the century there is no guarantee that plans are accurate. Once breached, there may be unexpected materials or inappropriate materials in the dam that would not support a partial breach option. Partial breaches may also create unanticipated new flow regimes.

Other considerations with multi-year projects include:

- Uncertainty of weather from year to year which may require additional measures to ensure partially breached dams are secure;
- Longer exposure of crews to accident vectors during the multi-seasons;
- Increased risk of personnel changes leading to loss of skills and experience; and
- Loss of availability of equipment.

Based on past experience, success with multi-year staged construction projects has been low.

The Forest Service does not recommend planning for a multi-year project to stabilize an individual dam. Further, they have advised that at the completion of each season of activity the partially-stabilized dam will be required to fully meet State of Utah and U.S. Forest Service dam safety specifications. Due to the existing condition of many of the dams, achieving this requirement could entail even more extensive work and could be more difficult to achieve than completing the stabilization to its final proposed configuration.

It was determined that this risk possibility was inconsistent with the projects goals of safety and stabilization as well as minimum impact and the preservation of the Wilderness resources and values.

As indicated by the concurrence page, the purposes of this memorandum are to document the design decisions and rationale used in the final design and to ensure that each of the participating agencies are

in agreement with and approve of the final design. This memorandum separately describes the design for each of the dams to be stabilized in the Brown Duck Basin.

Many of the design considerations and much of the logic and approach to this project is applicable for each of the dams. As such, the narratives described for Island Lake, are not fully repeated for Brown Duck Lake. Although there is some repetition, it is avoided to the extent possible to maintain a readable report.

The appendices contain design drawings and backup data that support the design conclusions and recommendations. Appendix A contains a copy of the MOU between the State of Utah and the U.S. Forest Service for dam safety. Appendix B contains design drawings showing location maps and applicable details for each of the lakes. Appendix C contains portions of the HEC-1 output files for the inflow hydrology that was performed on each of the lakes. The total output file for this work contains numerous pages, most of which is hydrograph data that is not necessarily meaningful to most readers. Rather than include the entire output, a select page that contains relevant flow data has been provided. The remaining output will be kept on file and made available upon request. Appendix D contains a summary table of the construction quantities for the designed work. Appendix E contains a summary of the Simplified Dam Break analysis for the lakes. The total output file for the dam break analysis also contains additional pages which are kept on file and are available upon request. Appendix F contains historical drawings of the dams and associated features.

Another item of note concerns the apparent elevation discrepancies between the various data sets. Each dam was topographically surveyed using global positioning satellite (GPS) equipment. The elevations measured and used for the drawings are actual elevations tied to the State Plane Coordinate System. However, the Digital Elevation Models (DEM) used for the hydrology and dam break analyses were obtained from the U.S. Geologic Survey (USGS) data base which does not necessarily match the State Plane elevations. Although there are differences, they can be accounted for and adjustments made accordingly. As long as the relative differences in elevation are accounted for, the data will be accurate and usable. Although some of the elevations for spillway and dam heights in the DEMs do not match the actual elevations as obtained through the surveys, they are still applicable because the relative differences are consistent.

Design Considerations

For each of the lakes a number of issues and considerations must be accounted for in the design. These include the following:

- Inflow hydrology
- Dam break analysis
- Outlet works removal or plugging with associated cutoffs and filters
- Outlet channel configuration including width, armoring, and side slopes
- Downstream connection to existing channel needs to accommodate drop in elevation between outlet channel and original ground. The downstream connection will need to be arranged in the field.

- All reasonable efforts will be made to blend outlet channel into the natural drainage in the area, by using boulder scatter or other techniques, to the extent that it does not require significant increase in resources to do so.

Summary									
Lake	Surface Area (ac)	Res. Volume (ac ft)	Dam Height (ft)	Basin Area (sq mi)	100 yr. Storm (in)	Peak Runoff (*)(cfs)	Max. Flow (cfs)	IDF (*)(cfs)	PMF (*)(cfs)
Island	26	688	16	0.7	2.62	91	128	1285	2030
Brown Duck	36	321	13	0.3	2.58	55	127	1270	2018

* - Peak runoff is for individual drainage basins. Maximum flow (PMF) is accumulated for Kidney, Island and Brown Duck. IDF = Individual Drainage Flood; PMF = Probable Maximum Flood.

Island Lake

Island Lake is located on Brown Duck Creek approximately ½ mile downstream of Kidney Lake and just above Brown Duck Lake. It has a surface area of about 26 acres at the spillway and holds approximately 688 acre-feet of water. The dam is 16 feet high composed primarily of a homogeneous embankment with rockfill in the downstream portion and has a 30-inch diameter low-level outlet located at the maximum section.

Inflow Hydrology

Island Lake is directly downstream of Kidney Lake and therefore comprises some of the same drainage basin. Most inflow hydrology is first routed through Kidney Lake and then into Island Lake. Because Island Lake is downstream, there is some additional drainage basin for this lake. The additional Island Lake drainage basin is 0.7 square miles for a total of 4.2 square miles in area. This area is comprised of partially wooded slopes, interspersed with brush and grassy areas. The WMS software package was used to model the drainage basin using the DEM obtained from the USGS web site. Hydrologic characteristics for the basin were then incorporated for full analysis. The 100-year, 6-hour storm estimate of 2.62 inches was obtained from the NOAA Precipitation Frequency Data Server, Atlas 14, Volume 1, Version 3. This storm has a volume of 20 acre-feet and a peak runoff of 91 cfs. However, when combined with the flows from Kidney Lake and routed through the reservoir, the peak runoff is attenuated to a maximum flow of 128 cfs through the outlet channel.

The Basin Average method was combined with the SCS Type-III, 6-hour curve to define the series. The SCS curve number method was used to model the basin losses, with a curve number of 69 (corresponding to AMC III fair conditions) provided by the State of Utah Office of Dam Safety. The SCS method was used within WMS to compute a Lag time of 1.4 hours. The Muskingum-Cunge method was used for stream routing with averaged stream characteristics based on actual survey data. Actual reservoir area-capacity curves were input for routing purposes.

Dam Break Analysis

The SMPDBK model contained within the WMS package was used to model multiple runs of dam break scenarios using varying parameters. Various breach outlet channel elevations were modeled to obtain maximum flows in the downstream channel so that the effects of a dam break could be understood and acceptable limits set. The dam break scenario table in Appendix E tabulates the results of various reservoir elevations and the corresponding dam break maximum flow.

A 15-foot-wide breach was used with a 300 minute time-to-breach, corresponding to half of the inflow hydrograph. A sunny day break of Island Lake Dam with the **outlet channel at elevation 10,249, the highest recommended elevation**, produces a maximum flow of 496 cubic feet per second and a water depth in the downstream channel averaging about 2.4 feet. By the time the breach flow reaches Moon Lake in 7.4 hours it is still 2.3 feet deep. Stream cross sections were determined by WMS from the DEM data and verified by cross-sectional surveys obtained by Reclamation survey crews.

Outlet Works

In order to have a no hazard classification there can be no operable outlet works. The existing outlet works could either be left in place and plugged or the entire outlet works could be removed. In either case the existing outlet works gate would be removed.

Generally, the preferred choice is to remove the outlet pipe, re-compact the trench from which it is pulled, and build the new outlet channel over top of the trench, with adequate protection to prevent erosion and down cutting. However, for the high mountain lakes stabilization project, a significant challenge is involved in re-compacting the fill material removed to the required density when the outlet pipe is pulled. This task is not likely feasible under conditions involving hand labor and primitive or traditional tools. It is also not likely to be achieved through use of hand-held powered compactors or by compaction from wheeled light equipment, if available.

Leaving the outlet pipe in place and plugging the pipe with non-shrink cement grout is an acceptable alternative. The outlet pipe at Clements Lake was treated in this manner and was done effectively. If the outlet pipe is grouted in place, about 14 CY of non-shrink cement would be needed to plug the pipe. The approximate formula for the grout will be 6 gallons of water and 6 oz. of Super-P per 94-lb. bag of Type II cement (final formula may be altered if needed for flowability and performance, with approval of Forest Service and State of Utah – Dam Safety Office).

The plugged outlet pipe will have protection at the upstream and downstream end in the form of a cement- or grout-filled rock gabion. The gabion at the downstream end will be followed by a filter material that will prevent migration of fines in the event that some water is able to flow through the grouted pipe. The grouting of the pipe should prevent any water flows through the pipe, but the gabion and filter are additional protection that provides redundancy in the design and will help to ensure a permanent fix.

The filter material will consist of a well-graded sand that will be obtained onsite. During excavation, sandy materials encountered will be stockpiled for use as the downstream filter. A 3/8-inch minus

screen will be utilized to remove any oversized material. The filter will be placed in the last 8 feet of the outlet works excavation trench resulting in an approximate volume of 5 to 6 cubic yards of material required. In the unlikely event that adequate sand is not available from onsite excavations, contingency plans would be required. This would include either locating an adequate source within the proximity of the work or flying in bagged sand by helicopter. Geotextile fabrics are not recommended due to the potential of plugging over time.

Outlet Channel

Based on the results of the dam break analysis and as shown on the drawings, the maximum recommended height of the outlet channel elevation should be set at no greater than 10,249 feet. The recommended finished width at the invert is 15 feet. Keeping the outlet channel a minimum width of 15 feet will help ensure that plugging due to ice, snow, and debris will be prevented. The amount of material to be excavated for the outlet channel is estimated at 1,800 cubic yards. The grade will be established and maintained by three grout- or concrete-filled rock gabion cutoffs – one at the inlet of the outlet channel, one mid-way through the outlet channel, and one at the downstream end of the outlet channel. The gabions will rise 1 foot above the excavated floor of the outlet channel notch, with a minimum of 2 feet of the gabion buried. Riprap will cover the top of the gabions. The design elevation of 10,249 will be measured at the top of the gabion basket in the channel bottom (excluding the low-flow notch). The outlet channel will be armored with a 24-inch thick layer of 12" D₅₀ riprap along the invert and for a vertical height of 5 to 6 feet on the side slopes. The remainder of the outlet channel side slopes may consist of smaller riprap armoring, depending on size of available riprap. The armoring of the invert and side slopes will provide protection against erosion and will ensure stable and permanent side slopes. It is critical that the toe of the side slopes does not experience erosion because of slope stability issues. Without toe protection, substantial erosion or undermining of the bottom of the side slopes could result in a complete slope failure. The floor of the outlet channel will be backfilled during the riprap placing process with finer-sized materials in order to provide a suitable layer of material that will be resistant to movement but that will force water flowing through the outlet channel to the surface of the channel invert, and not run under the riprap, thereby having an impassable outlet stream.

The outlet channel elevation was set to match the new reservoir level at the upstream and to tie into the existing stream channel on the downstream to provide as smooth and even of a transition as possible. The maximum grade within the outlet channel was limited to approximately five percent. In order to prevent erosion at the toe of the outlet channel slopes, in some cases this will require additional riprap armoring at the downstream end of the new outlet channel and existing outlet works channel transition due to several feet of drop required. Field crews will take care to minimize this drop by lengthening the downstream transition as much as possible.

A slope stability analysis was performed on the side slopes of the outlet channel. The slopes were required to be flat enough to allow a safety factor of at least 1.5 against failure. The existing embankment consists of cohesionless silty sands and some rockfill and an assumed friction angle of 31 degrees was used. Typical friction angle values for this type of material range from 30 to 32 degrees. To allow a higher friction angle than what was assumed would require a more thorough investigation of the material. Because of the nature of the materials, the cohesion was assumed to be zero.

Another factor that affects the results of the analysis is the assumed level of saturation within the embankment. For normal operating conditions, the saturation level will be less than 1 foot high. However, if the outlet channel was to become plugged or there was an extreme inflow event, the saturation level could become somewhat higher. The higher the saturation level, the flatter the side slopes need to be to maintain an adequate safety factor. In order to maintain a conservative design that will be considered to be permanent, a saturation level of 2 feet was used for the stability analysis. Although this level is likely to be higher than what will actually occur, the analysis did not assume any erosion of the toe and therefore should be considered as reasonable. It is possible through a combination of outlet channel plugging and high inflows that the saturation level of the embankment could rise above 1 foot. Therefore, a 2 foot high saturation level is not overly conservative. Based on the assumptions given above, the recommended slope configuration for the outlet channel is 2.5 horizontal to 1 vertical.

Because the main criteria for sizing the outlet channel width is to prevent snow, ice and debris from building up and blocking or plugging the channel, the recommended width of the channel is much greater than necessary to pass normal outlet channel outflows. Therefore, a low flow channel that will generally contain all outflows is incorporated into the design. Even for the 100 year storm outflow, the water level is less than 1.0 foot above the top of the low flow channel. Details of the low flow channel are not shown on the drawings in Appendix B; the design will be field-engineered to suit the encountered conditions.

The Storm Spillway Hydraulics table in Appendix C provides 100 year storm hydraulic data for the outlet channel flows for each of the dams.

Brown Duck Lake

Brown Duck Lake is located on Brown Duck Creek approximately ¼ mile downstream of Island Lake. It has a surface area of about 36 acres at the spillway and holds approximately 321 acre-feet of water. The dam is 13 feet high composed primarily of a homogeneous embankment with rockfill in the downstream portion and has a 30-inch diameter low-level outlet located at the maximum section.

Inflow Hydrology

Brown Duck Lake is directly downstream of Island and Kidney Lakes and also comprises some of the same drainage basin area. Inflow hydrology is first routed through Kidney and Island Lakes prior to getting to Brown Duck. The additional Brown Duck Lake drainage basin is 0.3 square miles for a total of 4.5 square miles in area. This area is comprised of partially wooded slopes, interspersed with brush, and grassy areas. The WMS software package was used to model the drainage basin using the DEM obtained from the USGS web site. Hydrologic characteristics for the basin were then incorporated for full analysis. The 100-year, 6-hour storm estimate of 2.58 inches was obtained from the NOAA Precipitation Frequency Data Server, Atlas 14, Volume 1, Version 3. This storm has a volume of 9 acre-feet and a peak runoff of 55 cfs. When combined with the flows from Kidney and Island Lakes and routed through the reservoir, the peak runoff is attenuated to a maximum flow of 127 cfs through the outlet channel.

The Basin Average method was combined with the SCS Type-III, 6-hour curve to define the series. The SCS curve number method was used to model the basin losses, with a curve number of 69 (corresponding to AMC III fair conditions) provided by the State of Utah Office of Dam Safety. The SCS method was used within WMS to compute a Lag time of 0.8 hours. The Muskingum-Cunge method was used for stream routing with averaged stream characteristics based on actual survey data. Actual reservoir area-capacity curves were input for routing purposes.

Dam Break Analysis

The SMPDBK model contained within the WMS package was used to model multiple runs of dam break scenarios using varying parameters. Various breach outlet channel elevations were modeled to obtain maximum flows in the downstream channel so that the effects of a dam break could be understood and acceptable limits set. The dam break scenario table in Appendix E tabulates the results of various reservoir elevations and the corresponding dam break maximum flow.

A 15-foot-wide breach was used with a 300 minute time-to-breach, corresponding to half of the inflow hydrograph. Because the volume of water at the natural lake level is so small, a sunny day break of Brown Duck Lake Dam with the outlet channel at elevation 10,193.5 produces a negligible maximum flow that displays as 0 cfs in the output data due to rounding. The water depth in the downstream channel is also negligible and displays at 0 feet. Stream cross sections were determined by WMS from the DEM data and verified by cross-sectional surveys obtained by Reclamation survey crews.

Outlet Works

The design criteria and rationale used for Island Lake equally apply to Brown Duck Lake and are not repeated herein. Refer to the Island Lake Outlet Works narrative for the complete discussion. If the outlet pipe is grouted in place and not removed, about 15 CY of non-shrink cement grout would be needed to plug the pipe.

Outlet channel

Except for the outlet channel invert elevation, the outlet channel discussion for Island Lake applies to Brown Duck Lake as well.

To enable a no hazard classification, the maximum height of the outlet channel elevation could be set at approximately 10,198 feet. However, it was decided to restore Brown Duck to close to the original natural lake level which results in a **recommended outlet channel elevation of 10,193.5 feet**. The amount of material to be excavated for the outlet channel is estimated at 945cubic yards. The grade will be established and maintained by three grout- or concrete-filled rock gabion cutoffs – one at the inlet of the outlet channel, one mid-way through the outlet channel, and one at the downstream end of the outlet channel. The gabions will rise 1 foot above the excavated floor of the outlet channel notch, with a minimum of 2 feet of the gabion buried. Riprap will cover the top of the gabions. The design elevation of 10,193.5 will be measured at the top of the gabion basket in the channel. The outlet channel will be

armored with a 20-inch thick layer of 10" D_{50} riprap along the invert and for a vertical height of 4 to 5 feet on the side slopes. The remainder of the spillway side slopes may consist of smaller riprap armoring, depending on size of available riprap. The maximum grade within the outlet channel was limited to approximately four percent. For a complete description of the rationale used to establish the outlet channel configuration, refer to the Island Lake Outlet channel discussion above.

Appendix A - Memorandum of Understanding between State of Utah and U.S. Forest Service

RECEIVED

JAN 20 1961

MEMORANDUM OF UNDERSTANDING

**DIVISION OF WATER RIGHTS
VERNAL, UTAH**

Intermountain Region
Forest Service
U. S. Department of Agriculture

Division of Water Rights
Department of Natural Resources
State of Utah

THIS MEMORANDUM OF UNDERSTANDING is entered into by the Division of Water Rights, Department of Natural Resources, State of Utah, hereafter called the Division, and the Intermountain Region, Forest Service, Department of Agriculture, hereafter referred to as the Forest Service.

WHEREAS, the Forest Service and the Division have certain responsibilities for the safety of dams by virtue of land status or public safety, and

WHEREAS, the Division has been created under Utah Statutes 73-5-5, 6, 7, 12, and 13, to provide public safety and resource protection by supervision and administration of a system to safeguard dams in the State of Utah, and

WHEREAS, the Forest Service under Acts of June 4, 1897 (16 U.S.C. 551), February 1, 1905 (16 U.S.C. 473), July 22, 1937 (16 U.S.C. 1010), June 12, 1960 (16 U.S.C. 528), as amended, is directed to regulate the occupancy and use of the National Forests and National Grasslands, and

WHEREAS, the Forest Service under administrative Manual requirements is directed to supervise and administer a system of inspections to safeguard dams located on National Forest lands, and

WHEREAS, the Forest Service and the Division mutually desire:

1. To periodically inspect dams located on National Forest lands.
2. To develop and document procedural methods to minimize duplication of effort and facilitate complementary inspections of dams.

NOW THEREFORE, the parties agree as follows:

1. The Forest Service agrees:
 - a. To coordinate with the Division at the local and state levels in developing an annual inspection schedule for dams.
 - b. To provide the Division copies of dam inspection reports made by Forest Service engineers.

High Lakes Stabilization Technical Memorandum

c. To notify the Division of suspected safety hazards of dams located on National Forest lands.

2. The Division agrees:

a. To provide notification to the appropriate Forest Supervisor of the dams scheduled for Division inspection each calendar year.

b. To provide the Forest Service copies of dam inspection reports made by Division engineers.

c. To notify the Forest Service of suspected safety hazards of dams located on, or affecting, National Forest lands.

3. It is mutually agreed:

a. To cooperate in the periodic inspection of dams located on National Forest lands in the State of Utah.

b. To develop and seek application of safety measures required to protect public safety and resources.

c. That nothing herein shall be construed in any way as limiting the authority of the Division in carrying out its legal responsibilities for management or regulation of dam safety.

d. That nothing herein shall be construed as limiting or affecting in any way the legal authority of the Forest Service in connection with the proper administration and protection of National Forest System lands, in accordance with Federal laws and regulations.

e. That nothing in the Memorandum of Understanding shall be construed as obligating the Forest Service or the Division to expend funds in any contract or other obligation for future payment of funds or services in excess of those available or authorized for expenditure.

f. That amendments to this Memorandum of Understanding may be proposed by either party and shall become effective after written approval by both parties.

g. That this Memorandum of Understanding shall continue in force unless terminated by either party upon thirty (30) days notice in writing to the other of intention to terminate upon a date indicated.

h. Forest Service and local Division inspection personnel¹ will coordinate their annual inspection schedules to avoid duplication of effort.

¹ See Exhibit 1 attached hereto.

High Lakes Stabilization Technical Memorandum

c. To notify the Division of suspected safety hazards of dams located on National Forest lands.

2. The Division agrees:

a. To provide notification to the appropriate Forest Supervisor of the dams scheduled for Division inspection each calendar year.

b. To provide the Forest Service copies of dam inspection reports made by Division engineers.

c. To notify the Forest Service of suspected safety hazards of dams located on, or affecting, National Forest lands.

3. It is mutually agreed:

a. To cooperate in the periodic inspection of dams located on National Forest lands in the State of Utah.

b. To develop and seek application of safety measures required to protect public safety and resources.

c. That nothing herein shall be construed in any way as limiting the authority of the Division in carrying out its legal responsibilities for management or regulation of dam safety.

d. That nothing herein shall be construed as limiting or affecting in any way the legal authority of the Forest Service in connection with the proper administration and protection of National Forest System lands, in accordance with Federal laws and regulations.

e. That nothing in the Memorandum of Understanding shall be construed as obligating the Forest Service or the Division to expend funds in any contract or other obligation for future payment of funds or services in excess of those available or authorized for expenditure.

f. That amendments to this Memorandum of Understanding may be proposed by either party and shall become effective after written approval by both parties.

g. That this Memorandum of Understanding shall continue in force unless terminated by either party upon thirty (30) days notice in writing to the other of intention to terminate upon a date indicated.

h. Forest Service and local Division inspection personnel¹ will coordinate their annual inspection schedules to avoid duplication of effort.

¹ See Exhibit 1 attached hereto.

Appendix B - Drawings

D

D

C

C

B

B

A

A

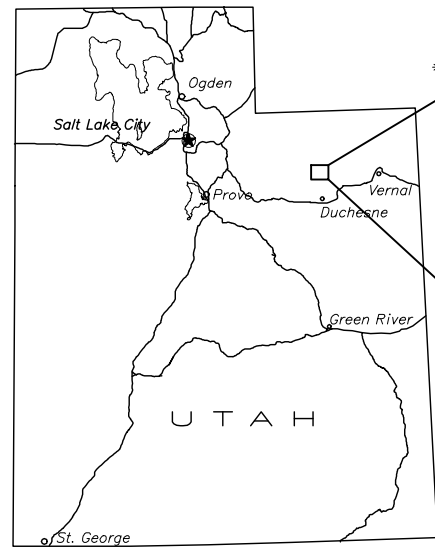

KEY MAP

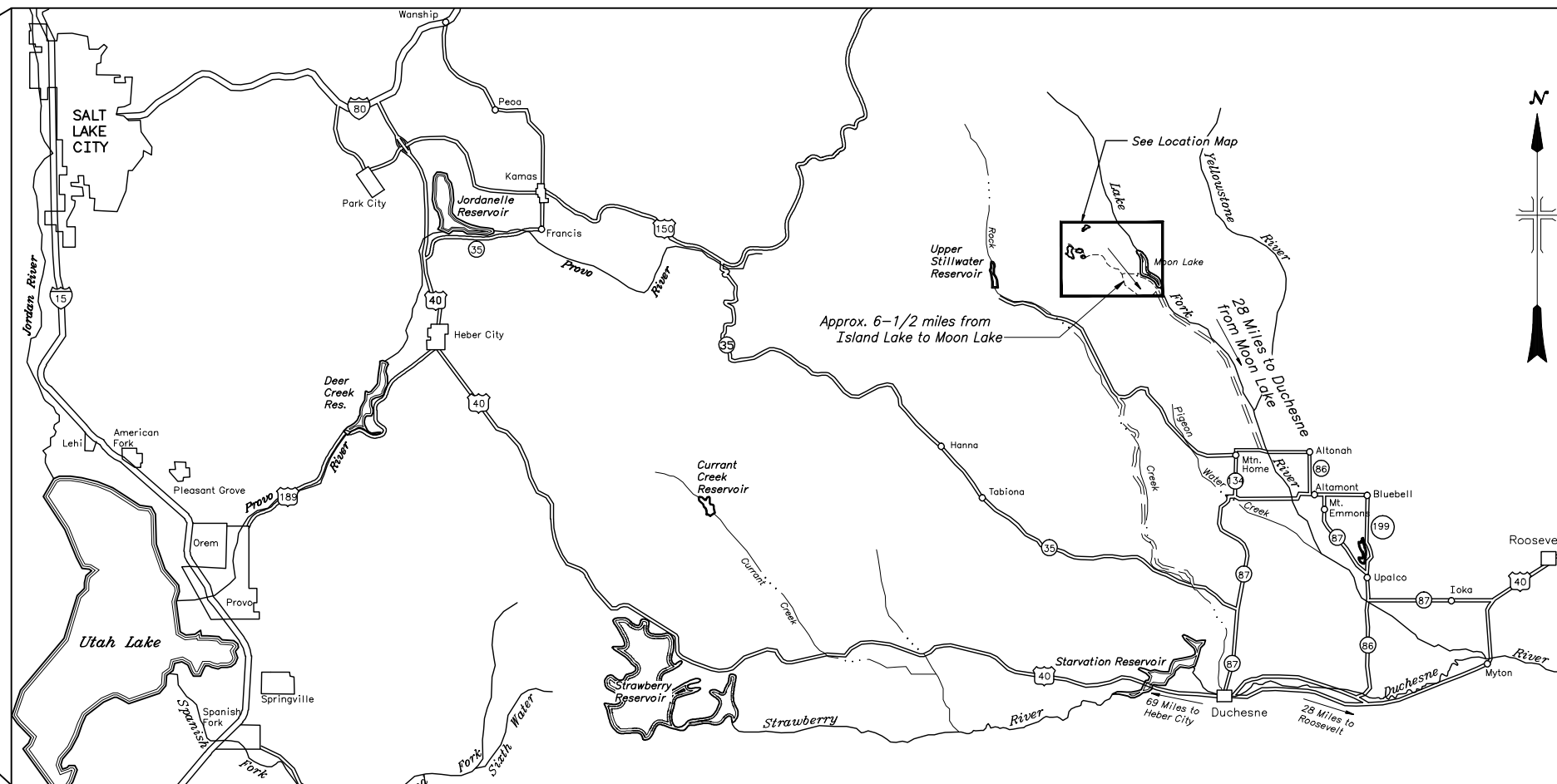

VICINITY MAP

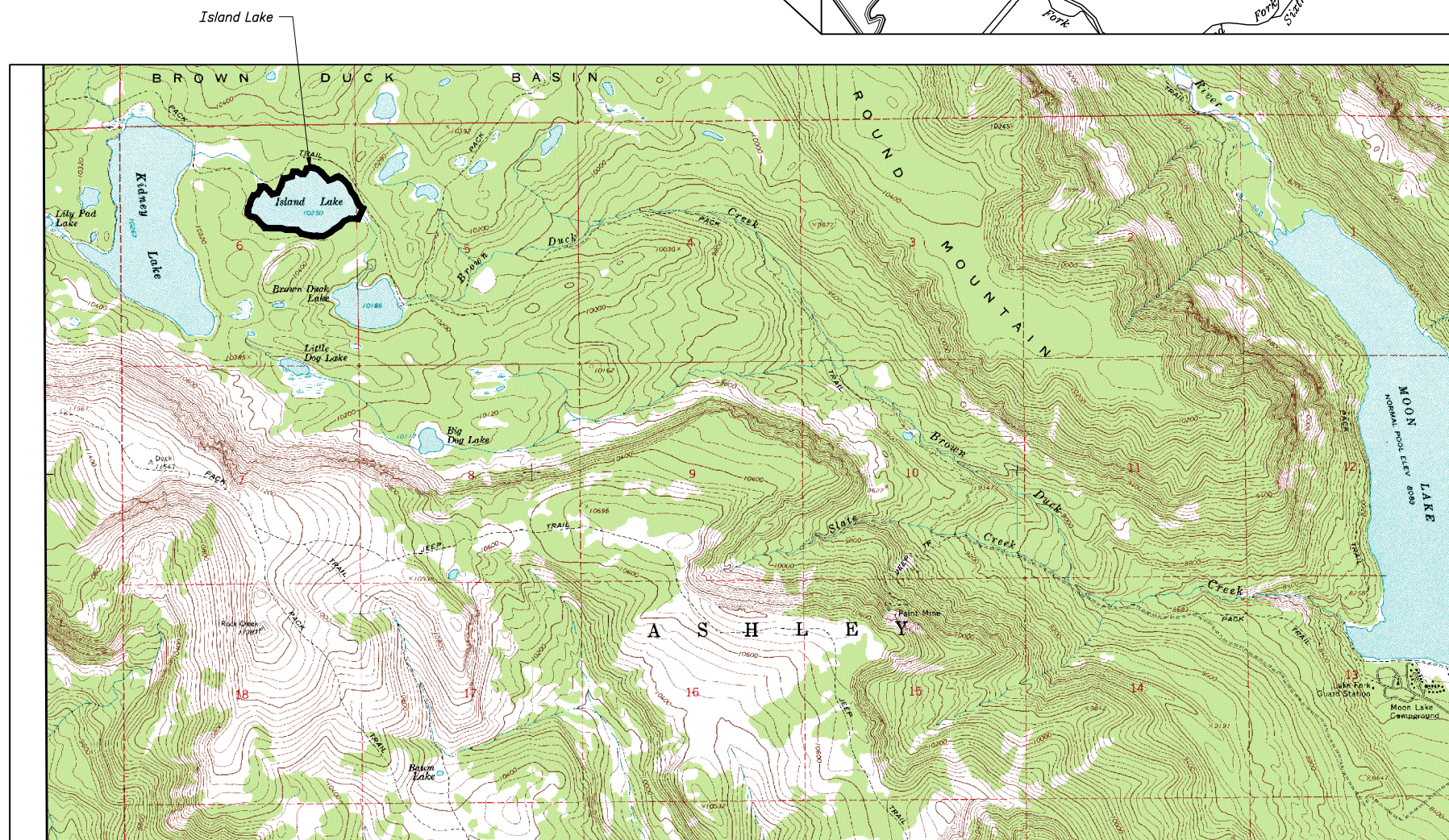
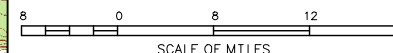

LOCATION MAP
NOT TO SCALE

 **ALWAYS THINK SAFETY**
 UNITED STATES
 DEPARTMENT OF THE INTERIOR
 BUREAU OF RECLAMATION
 PROVO AREA OFFICE
 PROVO, UTAH
**BROWN DUCK BASIN LAKES
 DAM STABILIZATION
 ISLAND LAKE
 VICINITY AND LOCATION MAP**
 DESIGNED */s/ Diane Loft* CHECKED */s/ Scott Winterton, P.E.*
 DRAWN */s/ Diane Loft* TECH. APPR. */s/ Cary Southworth, P.E.*
 APPROVED */s/ Clyde Thomas, P.E.*
CLYDE THOMAS, P.E. - PEER REVIEWER
 PROVO, UTAH 2887-84-18 **OA58-418-74**

DATE AND TIME PLOTTED
 3-16-05 2:16 PM
 PLOTTED BY
 SWINTERSON
 CAD SYSTEM
 AUTOCAD 2005
 CAD FILENAME
 I:\projects\Island Locatmap.DWG

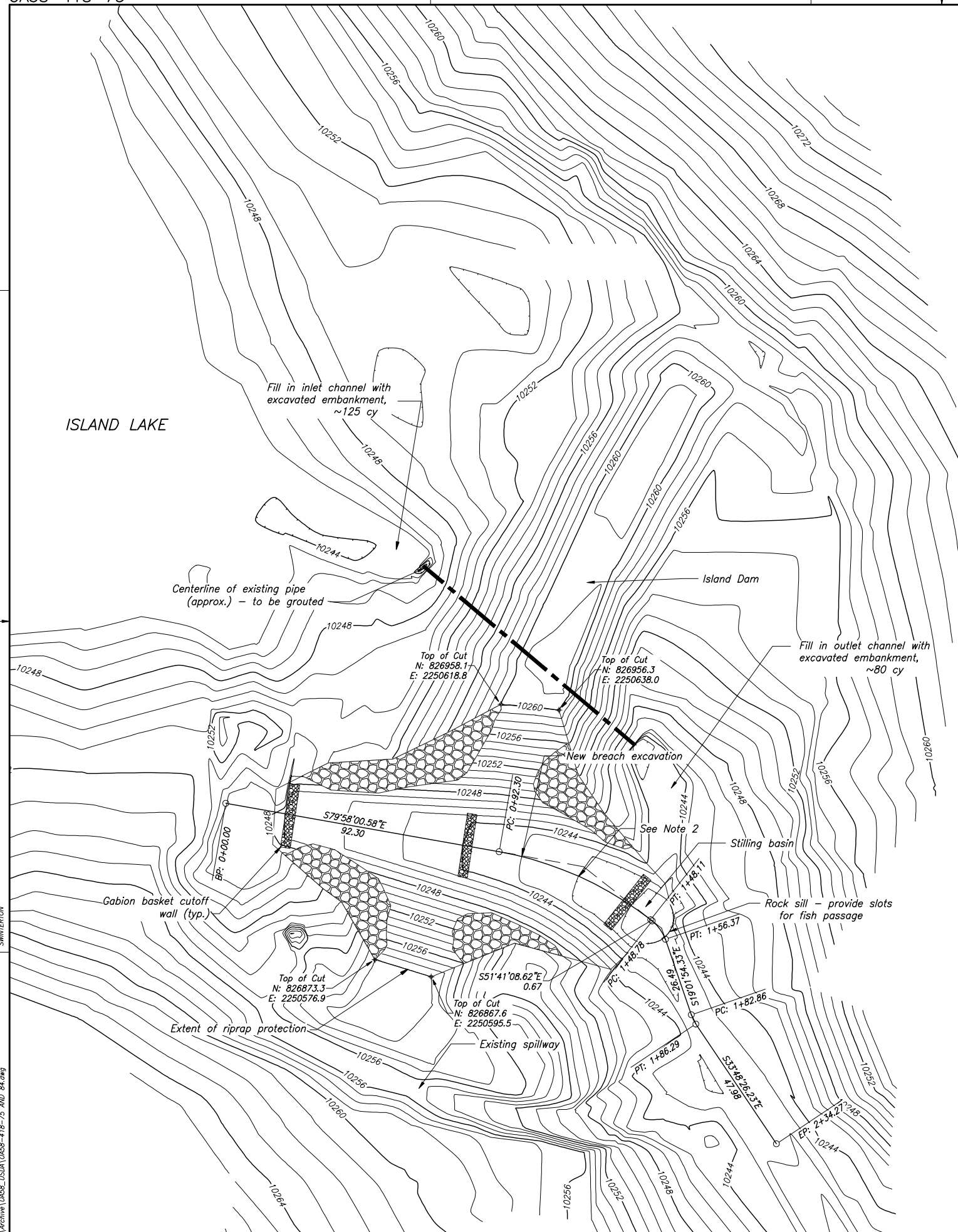

PROFILE: RIGHT ABUTMENT BREACH

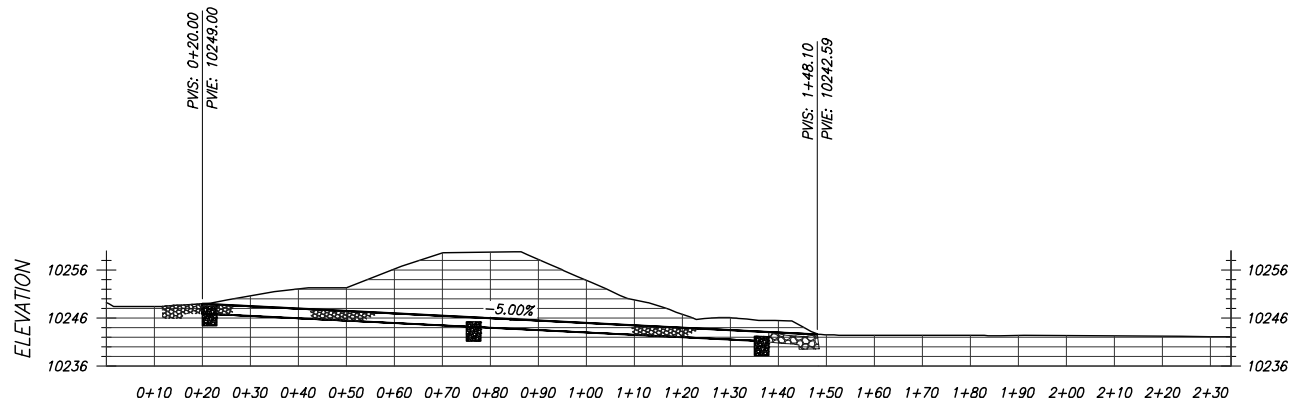

HORIZONTAL GEOMETRY	92.30	0.67	26.49	47.98
	PI STA: 1+20.79	PI STA: 1+52.68	PI STA: 1+84.58	
	DELTA: 28.28	DELTA: 32.65	DELTA: 14.78	
	R: 113.05	R: 13.31	R: 13.31	
	L: 55.80	L: 7.58	L: 3.43	

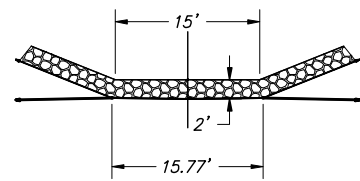

Breach - 24" Riprap Thickness
 15 ft. bottom width
 Depth to daylight
 2.5:1 Cut slopes

NOTES

1. Contour interval is 1 foot.
2. Vary centerline alignment along ramp to create resting pools.
3. Breach El. 10,249.00
4. Cut vol. = 1,773 c.y.
5. Contours shown through the breach represent excavated grade below final riprap placement.
6. Grid factor = 0.99949466

DATE AND TIME PLOTTED
 3--16--08 2:56 PM
 PLOTTED BY
 SWINTERSON

CAD SYSTEM
 AUTOCAD 2005
 CAD FILENAME
 I:\archive\0468_052A\0468-418-75 AND 84.dwg

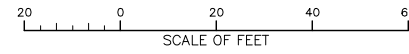

ALWAYS THINK SAFETY

UNITED STATES
 DEPARTMENT OF THE INTERIOR
 BUREAU OF RECLAMATION
 PROVO AREA OFFICE
 PROVO, UTAH

**BROWN DUCK BASIN LAKES
 DAM STABILIZATION
 ISLAND LAKE SPILLWAY MODIFICATION
 SITE PLAN**

DESIGNED */s/ Scott Winterton, P.E.* CHECKED */s/ Mike Talbot, P.E.*
 DRAWN */s/ Scott Winterton, P.E.* TECH. APPR. */s/ Cary Southworth, P.E.*
 APPROVED */s/ Clyde Thomas, P.E.*
 PEER REVIEWER

PROVO, UTAH 2007-12-20 **OA58-418-75**
 SHEET NUMBER

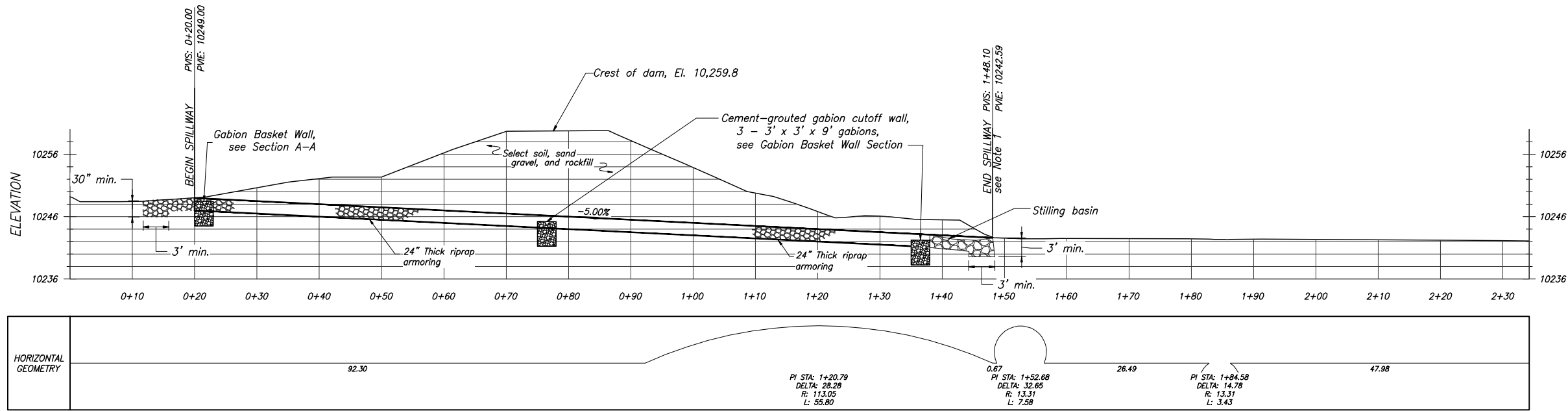

BREACH PROFILE

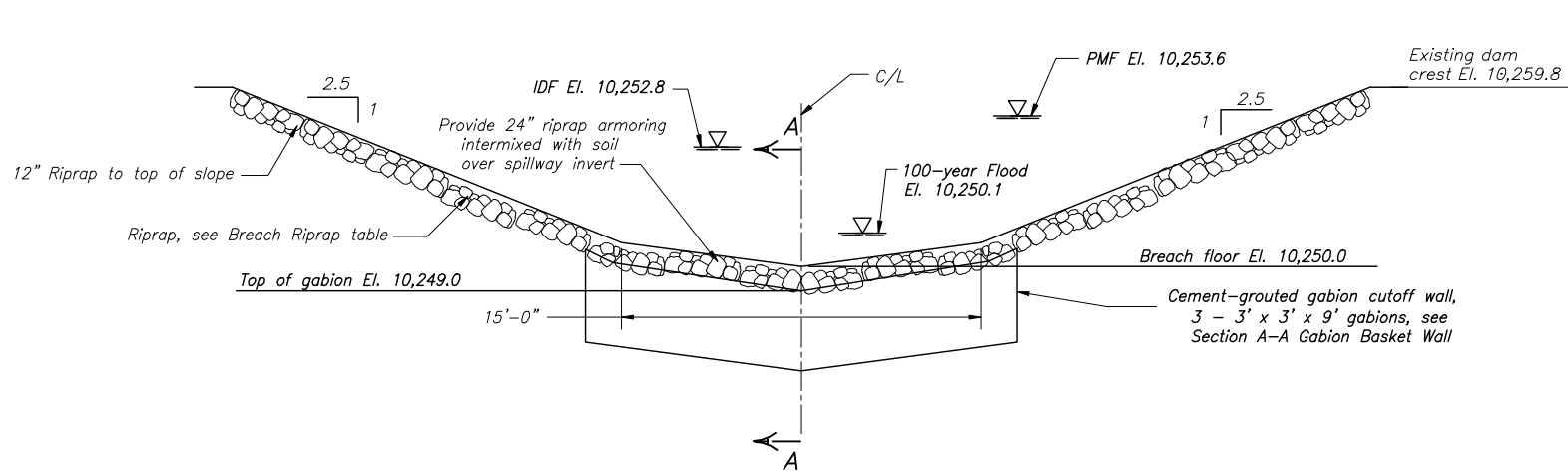

BREACH CHANNEL ELEVATION AT STA. 20+00

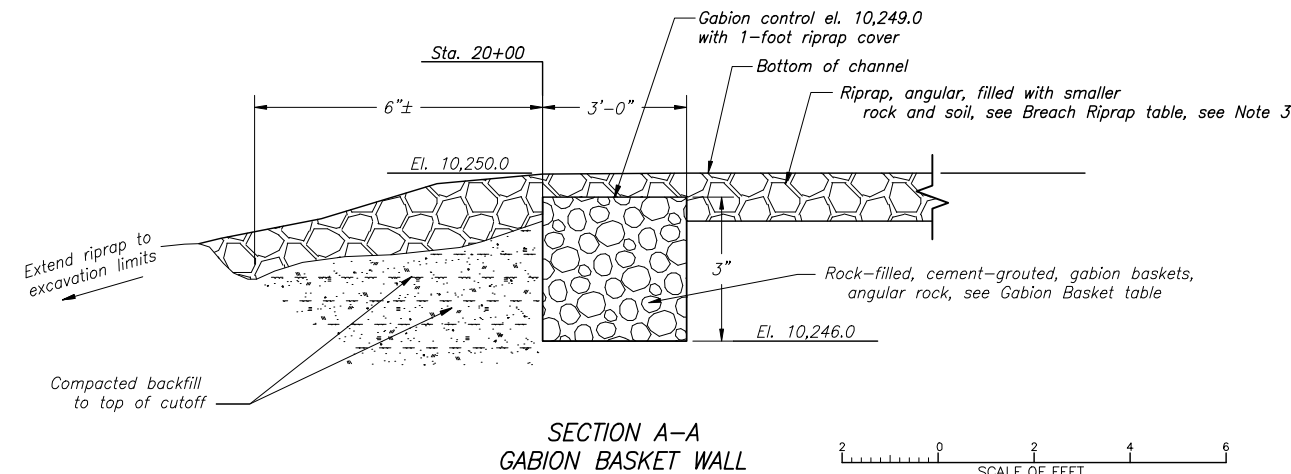

SECTION A-A GABION BASKET WALL

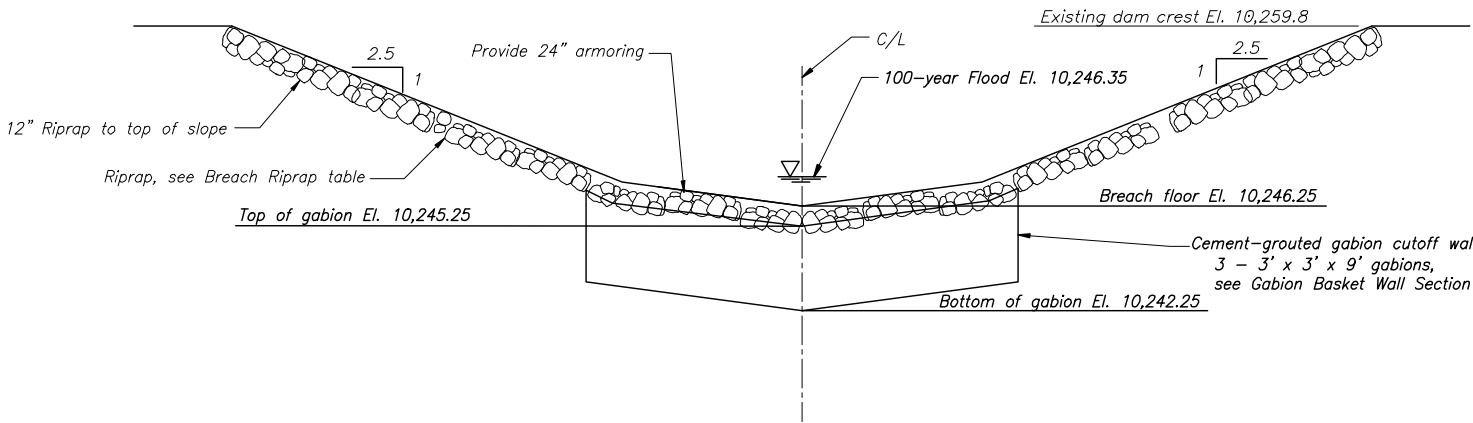

BREACH CHANNEL ELEVATION AT STA. 75+00

GABION BASKET			
GABION BASKET	PREDOMINATE ROCK SIZE (INCHES)	MINIMUM ROCK SIZE (INCHES)	MAXIMUM ROCK SIZE (INCHES)
36	6 to 10	4	12

BREACH RIPRAP					
HEIGHT ABOVE INVERT	D MIN.	D15	D50	D MAX.	THICKNESS MIN.
0-5'	4"	8"	12"	16"	24"
5'-Dam Crest	2"	4"	6"	9"	12"

- NOTES**
1. Provide riprap armoring from end of breach to existing ground to prevent headcutting and erosion.
 2. Flood elevations through the breach represent elevations as if the existing spillway does not operate.
 3. Place riprap through breach in layers to maintain correct gradations.

REV NO: 2008-1-14
 1 418 SMW
 Added row to Breach Riprap Table, modified notes on breach sections to reflect 12" thick riprap layer to dam crest

ALWAYS THINK SAFETY

UNITED STATES
 DEPARTMENT OF THE INTERIOR
 BUREAU OF RECLAMATION
 PROVO AREA OFFICE
 PROVO, UTAH

**BROWN DUCK BASIN LAKES
 DAM STABILIZATION**
 ISLAND LAKE SPILLWAY MODIFICATION
 BREACH PROFILE, ELEVATIONS, AND SECTION

DESIGNED: /s/ Scott Winterton, P.E. CHECKED: /s/ Mike Talbot, P.E.
 DRAWN: /s/ Dianne Loft, P.E. TECH. APPR: /s/ Cary Southworth, P.E.
 APPROVED: /s/ Clyde Thomas, P.E.
 PEER REVIEWER

PROVO, UTAH 2007-12-20 **OA58-418-84**

DATE AND TIME PLOTTED: 14-Nov-08 1:31 PM
 PLOTTED BY: SWINTERSON
 CAD SYSTEM: AUTOCAD 2005
 CAD FILENAME: I:\Archive\0468_USDA\0468-418-75 AND 84-R1.dwg

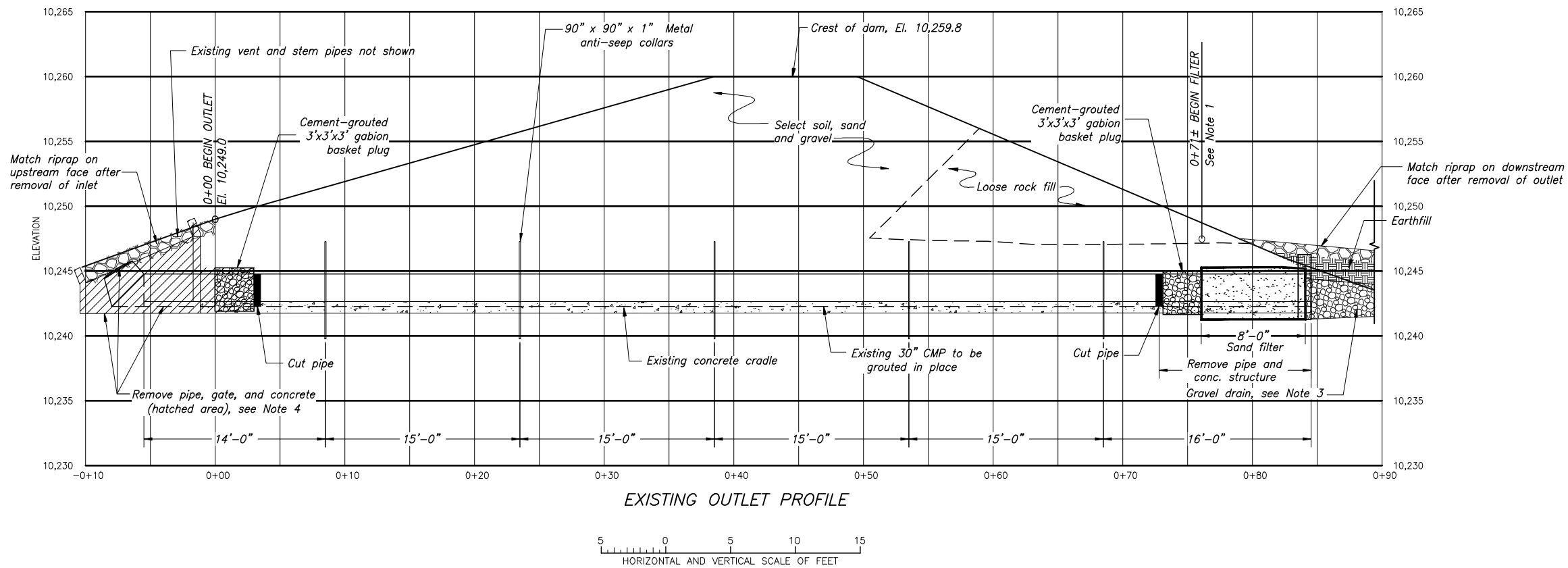

SAND FILTER MATERIAL GRADATION REQUIREMENTS

SIEVE SIZE	% PASSING BY WEIGHT
1/2 inch	100
3/8 inch	100
No. 4	95-100
No. 8	80-100
No. 16	50-85
No. 30	25-60
No. 50	10-30
No. 100	2-10
No. 200	0-3

GRAVEL DRAIN MATERIAL GRADATION REQUIREMENTS

SIZE	% PASSING BY WEIGHT
1 1/2 inch	90-100
3/4 inch	55-100
3/8 inch	19-75
No. 4	0-40
No. 8	0-10
No. 16	0

NOTES

1. Provide compacted filter material over last 8 feet of pipe removal trench.
2. Trench walls shall be sloped to allow adequate compaction between fill and natural ground. Actual slope will depend on compaction method used.
3. Extend gravel drain through compacted sloped ramp material to discharge under riprap.
4. Fill inlet area with embankment material compacted to 95% maximum density.

DATE AND TIME PLOTTED: 14-Nov-08 2:10 PM
 PLOTTED BY: SWINTERSON
 CAD SYSTEM: AUTOCAD 2005
 CAD FILENAME: I:\Archive\0488_USDA\0488-418-76-R1.dwg

REV NO 1 2008-1-14 418 SMW Changed size of gabion plug to 3'x3'x3' and added upstream plug at inlet

ALWAYS THINK SAFETY

UNITED STATES
 DEPARTMENT OF THE INTERIOR
 BUREAU OF RECLAMATION
 PROVO AREA OFFICE
 PROVO, UTAH

**BROWN DUCK BASIN LAKES
 DAM STABILIZATION
 ISLAND LAKE SPILLWAY MODIFICATION
 EXISTING OUTLET PROFILE**

DESIGNED /s/ Scott Winterton, P.E. CHECKED /s/ Mike Talbot, P.E.
 DRAWN /s/ Dianne Loft TECH. APPR. /s/ Cary Southworth, P.E.
 APPROVED /s/ Clyde Thomas, P.E.
 CLYDE THOMAS, P.E. - PEER REVIEWER

PROVO, UTAH 2007-12-03 OA58-418-76

D

D

C

C

B

B

A

A

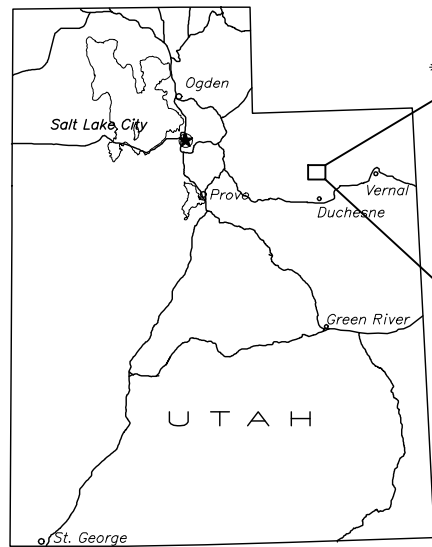

KEY MAP

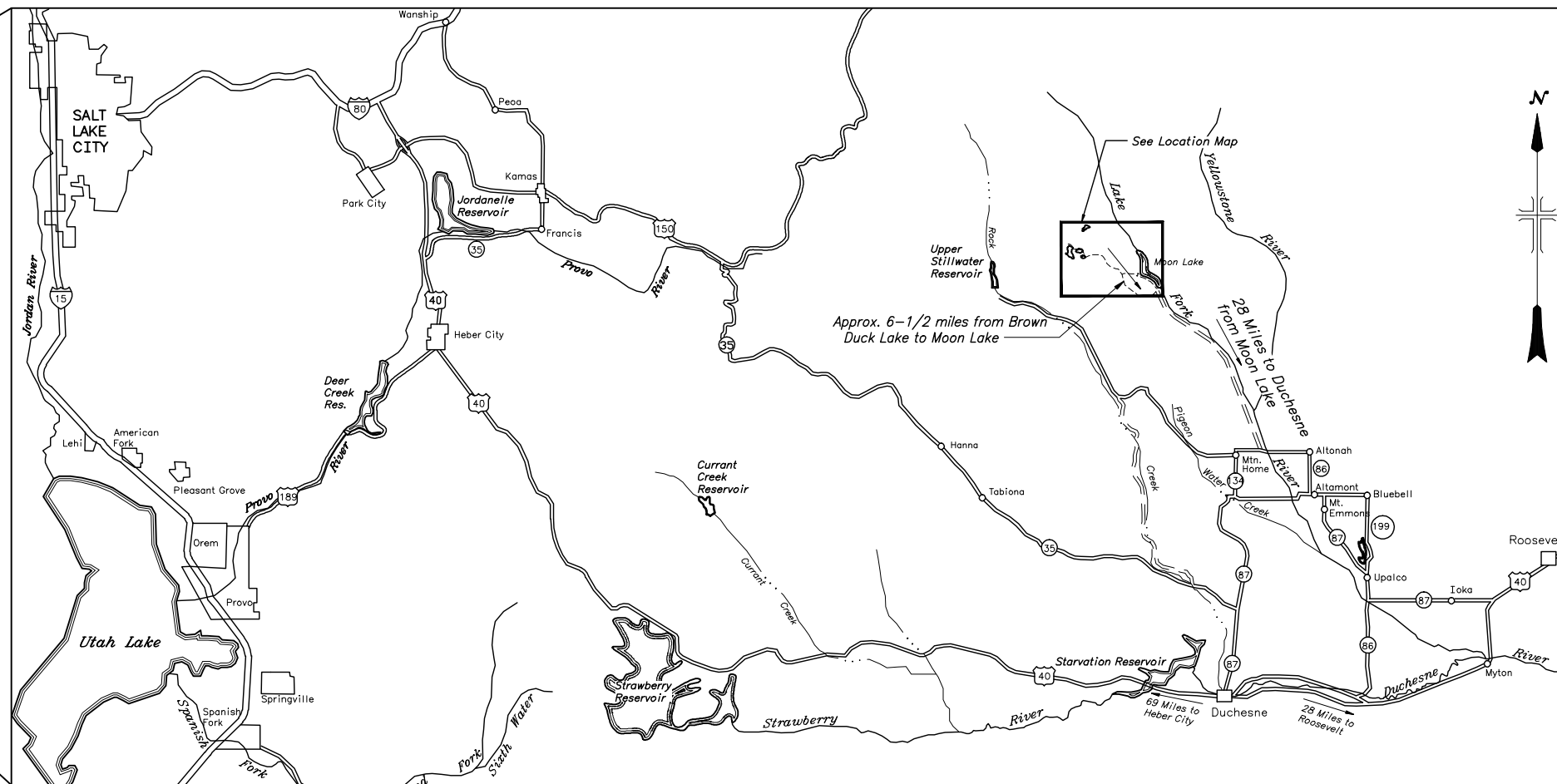

VICINITY MAP

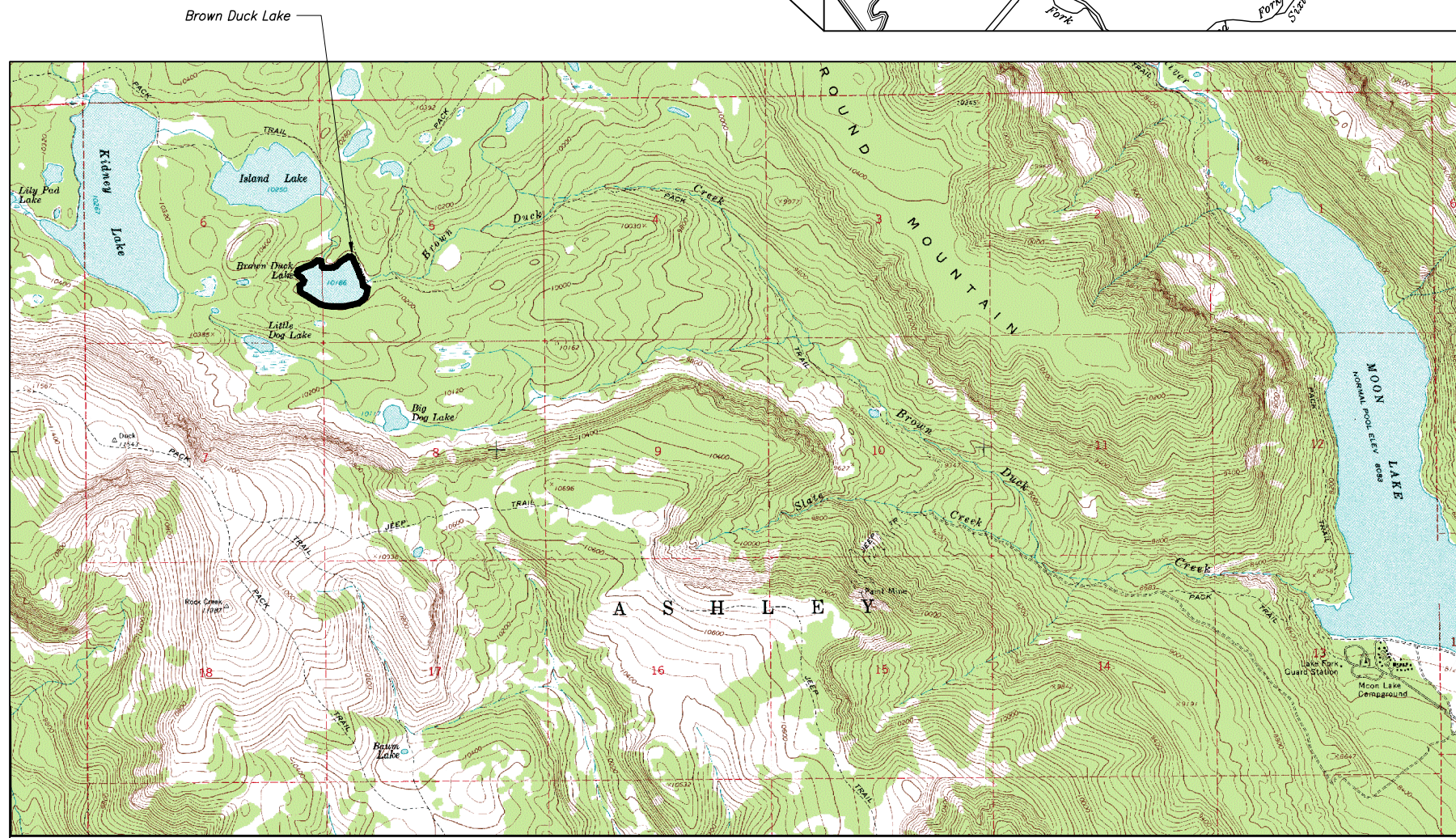
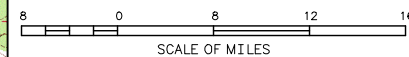

LOCATION MAP
NOT TO SCALE

ALWAYS THINK SAFETY

UNITED STATES
DEPARTMENT OF THE INTERIOR
BUREAU OF RECLAMATION
PROVO AREA OFFICE
PROVO, UTAH

**BROWN DUCK BASIN LAKES
DAM STABILIZATION
BROWN DUCK LAKE
VICINITY AND LOCATION MAP**

DESIGNED */s/ Dianne Loft* CHECKED */s/ Scott Winterton, P.E.*
DRAWN */s/ Dianne Loft* TECH. APPR. */s/ Cary Southworth, P.E.*
APPROVED */s/ Clyde Thomas, P.E.*
CLYDE THOMAS, P.E. - PEER REVIEWER

PROVO, UTAH 2007-04-15 OA58-418-68

DATE AND TIME PLOTTED
 3-16-07 8:22:21 PM
 PLOTTED BY
 SWINTERION
 CAD SYSTEM
 AUTOCAD 2005
 CAD FILENAME
 F:\archive\0458_OA58-418-68.dwg



PROFILE: RIGHT ABUTMENT BREACH

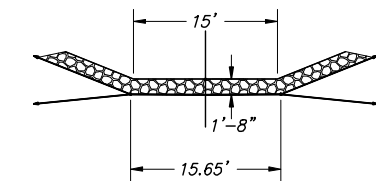
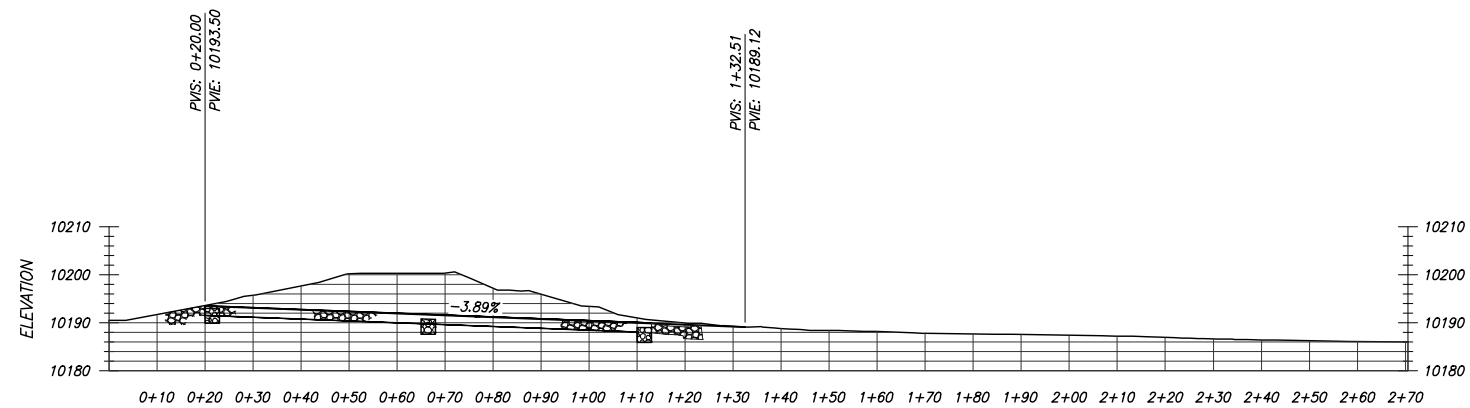

Breach - 20 inch riprap depth
 15 ft. bottom width
 1.667 ft. riprap thickness
 2.5:1 Cut slopes

NOTES

1. Contour interval is 1 foot.
2. Vary centerline alignment along ramp to create resting pools.
3. Breach El. 10,193.50
4. Cut vol. = 945 c.y.
5. Contours shown through the breach and outlet channel represent excavated grade below final riprap placement.
6. Grid factor = 0.99949466

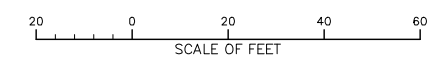
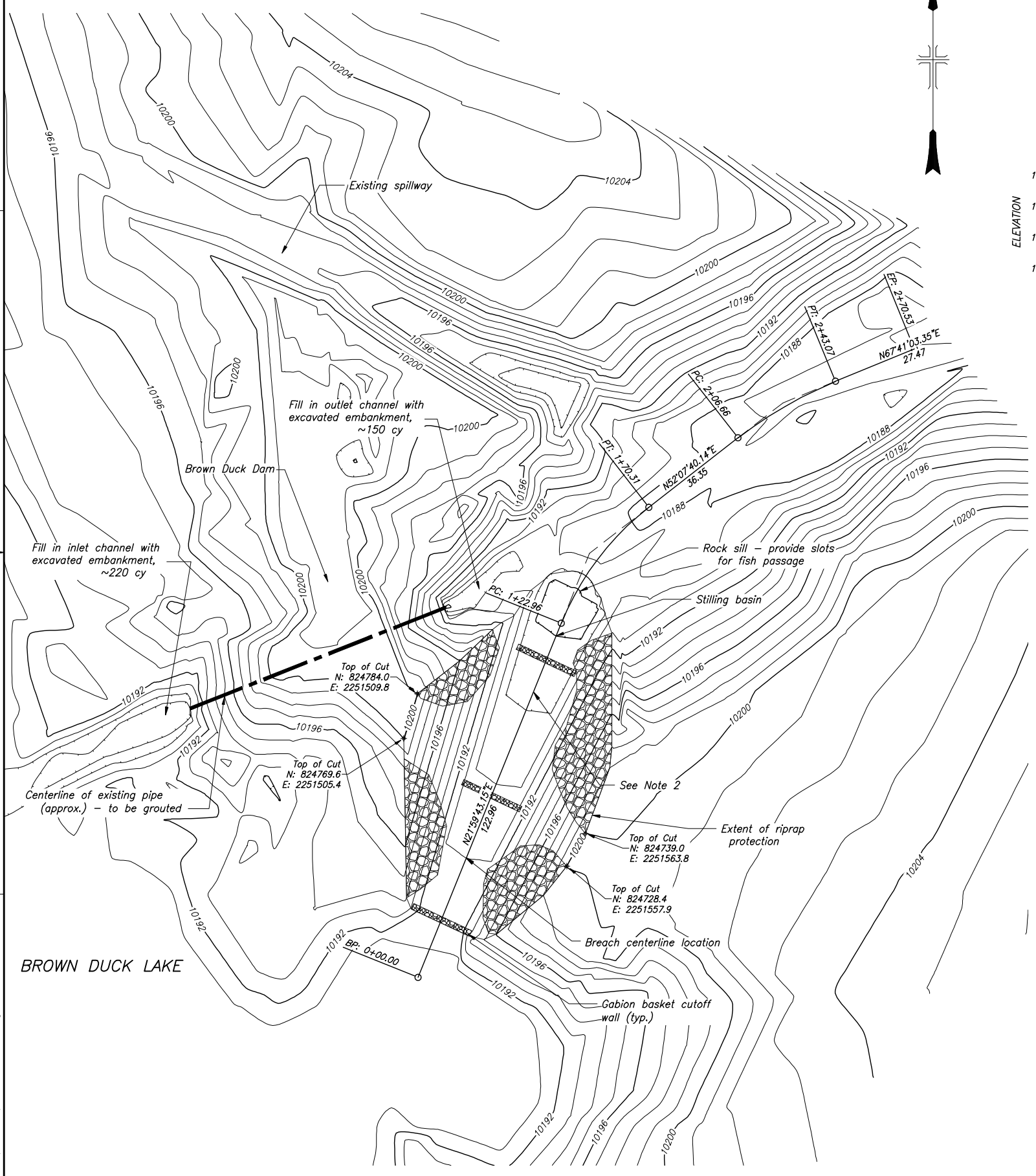

DATE AND TIME PLOTTED
 3-16-08 2:59 PM
 PLOTTED BY
 SWINTERSON
 CAD SYSTEM
 AUTOCAD 2005
 CAD FILENAME
 I:\Archive\0468_USDA\0468-418-69 AND 80.dwg

ALWAYS THINK SAFETY

UNITED STATES
 DEPARTMENT OF THE INTERIOR
 BUREAU OF RECLAMATION
 PROVO AREA OFFICE
 PROVO, UTAH

**BROWN DUCK BASIN LAKES
 DAM STABILIZATION**
 BROWN DUCK LAKE SPILLWAY MODIFICATION
 SITE PLAN

DESIGNED */s/ Scott Winterton, P.E.* CHECKED */s/ Mike Talbot, P.E.*
 DRAWN */s/ Scott Winterton, P.E.* TECH. APPR. */s/ Cary Southworth, P.E.*
 APPROVED */s/ Clyde Thomas, P.E.*
 PEER REVIEWER

PROVO, UTAH 2007-12-20

OA58-418-69

SHEET NUMBER

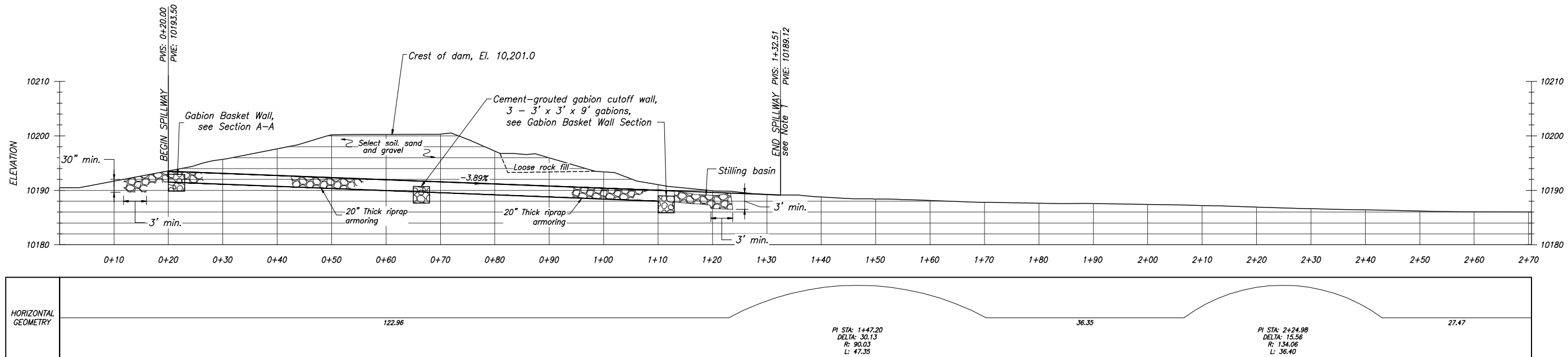

BREACH PROFILE

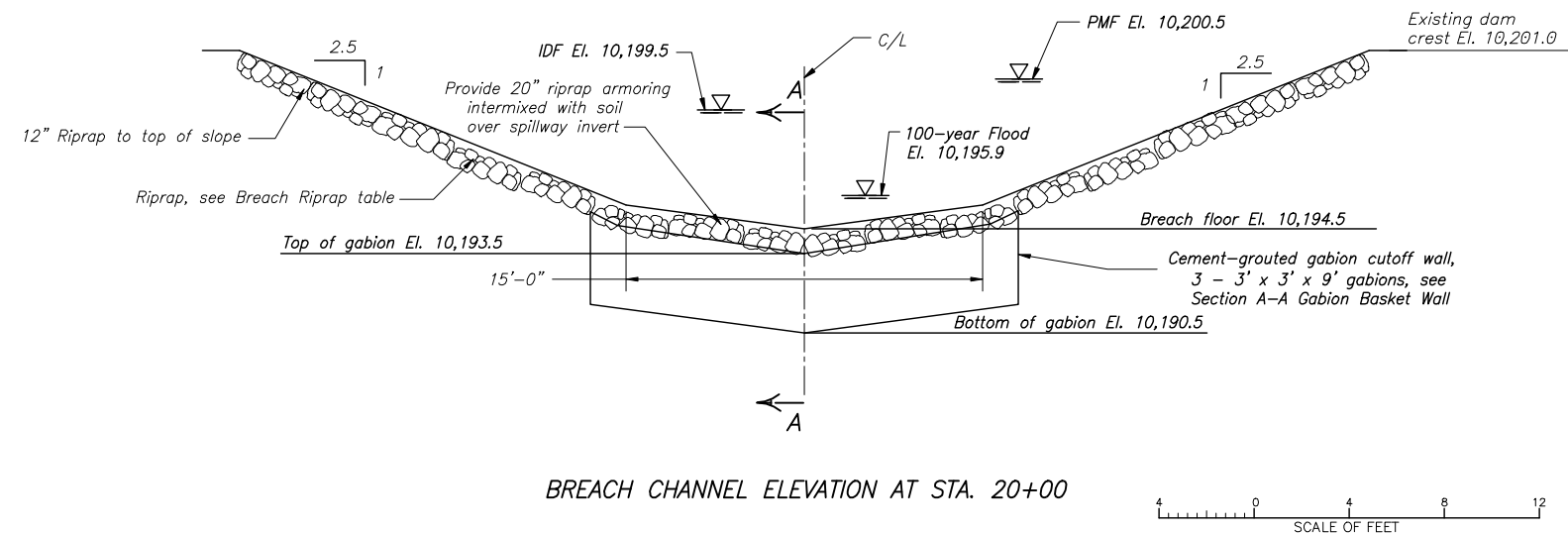

BREACH CHANNEL ELEVATION AT STA. 20+00

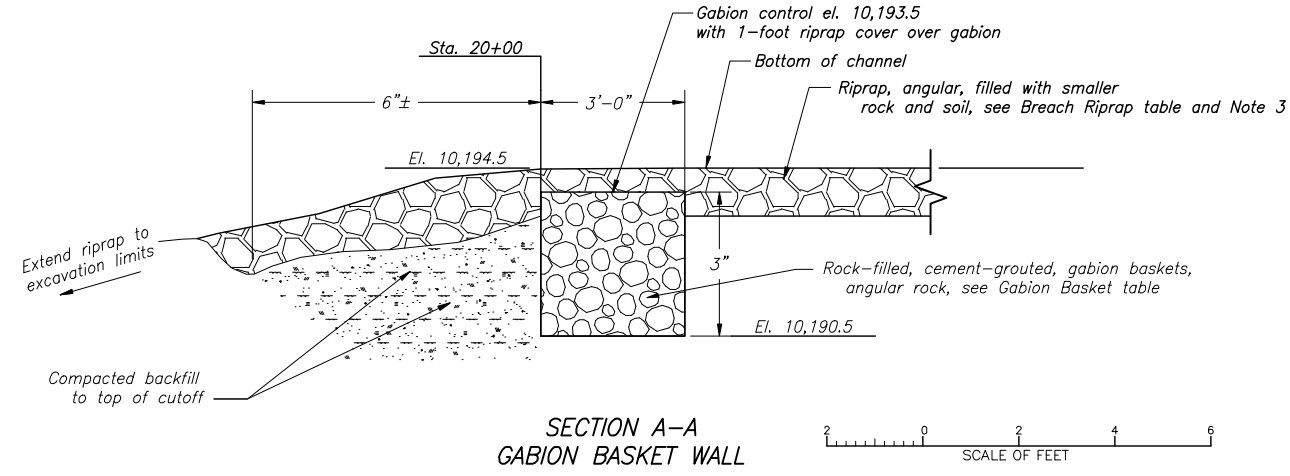

SECTION A-A GABION BASKET WALL

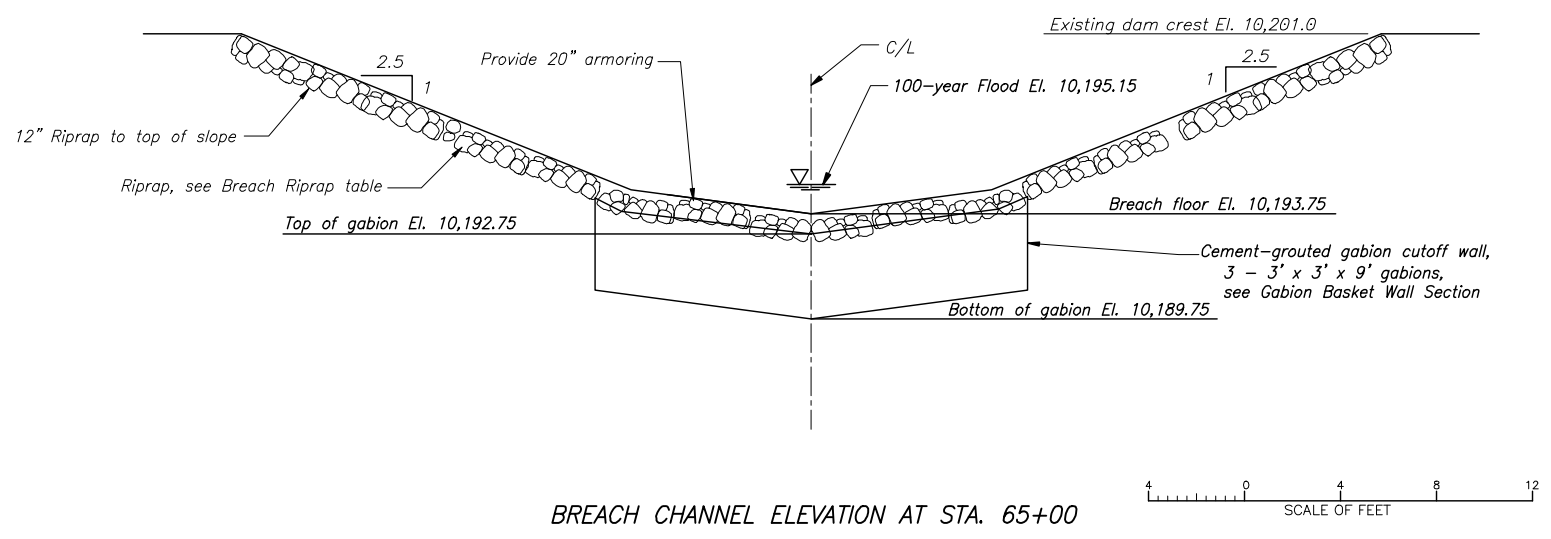

BREACH CHANNEL ELEVATION AT STA. 65+00

GABION BASKET			
GABION BASKET	PREDOMINATE ROCK SIZE (INCHES)	MINIMUM ROCK SIZE (INCHES)	MAXIMUM ROCK SIZE (INCHES)
36	6 to 10	4	12

BREACH RIPRAP					
HEIGHT ABOVE INVERT	D MIN.	D15	D50	D MAX.	THICKNESS MIN.
0-5'	4"	6"	10"	14"	20"
5'-Dam Crest	2"	4"	6"	9"	12"

- NOTES**
1. Provide riprap armoring from end of spillway to existing ground to prevent headcutting and erosion.
 2. Flood elevations through the breach represent elevations as if the existing spillway does not operate.
 3. Place riprap through breach in layers to maintain correct gradations.

REV NO 2008-1-14
1 418 SMW
Added row to Breach Riprap Table, modified notes on breach sections to reflect 12" thick riprap layer to dam crest

ALWAYS THINK SAFETY

UNITED STATES
DEPARTMENT OF THE INTERIOR
BUREAU OF RECLAMATION
PROVO AREA OFFICE
PROVO, UTAH

**BROWN DUCK BASIN LAKES
DAM STABILIZATION**
BROWN DUCK LAKE SPILLWAY MODIFICATION
BREACH PROFILE, ELEVATIONS, AND SECTION

DESIGNED /s/ Scott Winterton, P.E. CHECKED /s/ Mike Talbot, P.E.
DRAWN /s/ Dianne Loft TECH. APPR. /s/ Cary Southworth, P.E.
APPROVED /s/ Clyde Thomas, P.E.
PEER REVIEWER

PROVO, UTAH 2007-12-20

DATE AND TIME PLOTTED 14-Nov-08 1:34 PM
 PLOTTED BY SWINTERSON
 CAD SYSTEM AUTOCAD 2005
 CAD FILENAME I:\Archive\0468_USDA\0468-418-69 AND 80-R1.dwg

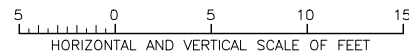
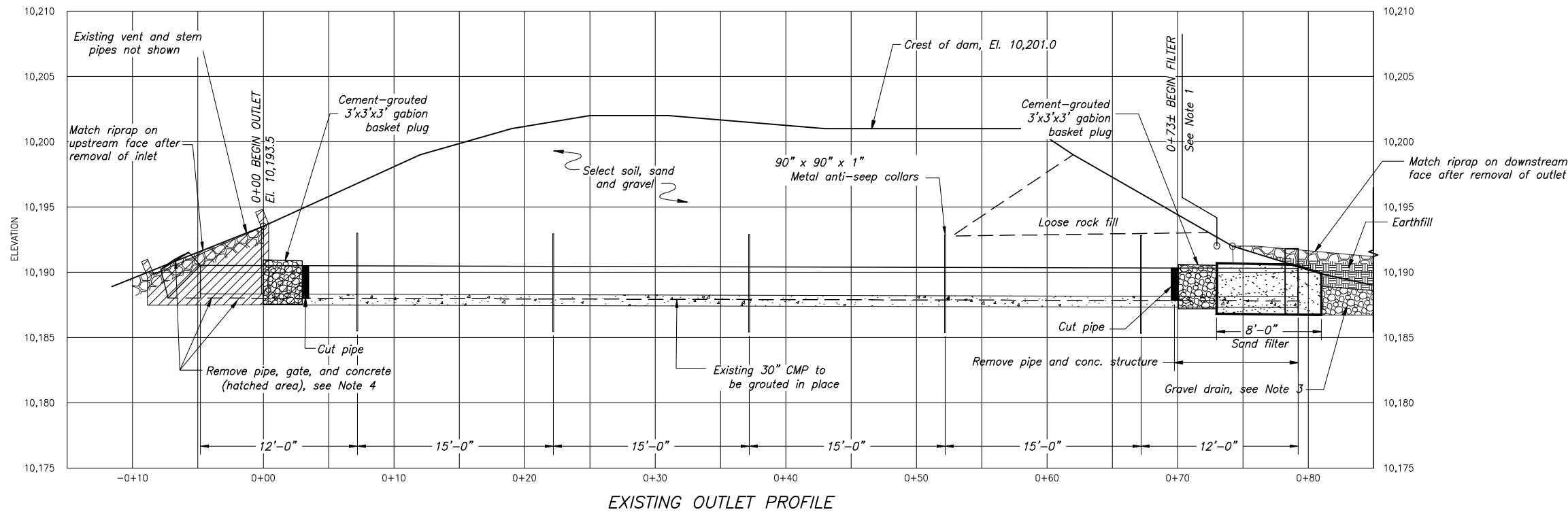

SAND FILTER MATERIAL GRADATION REQUIREMENTS	
SIEVE SIZE	% PASSING BY WEIGHT
1/2 inch	100
3/8 inch	100
No. 4	95-100
No. 8	80-100
No. 16	50-85
No. 30	25-60
No. 50	10-30
No. 100	2-10
No. 200	0-3

GRAVEL DRAIN MATERIAL GRADATION REQUIREMENTS	
SIZE	% PASSING BY WEIGHT
1 1/2 inch	90-100
3/4 inch	55-100
3/8 inch	19-75
No. 4	0-40
No. 8	0-10
No. 16	0

NOTES

1. Provide compacted filter material over last 8 feet of pipe removal trench.
2. Trench walls shall be sloped to allow adequate compaction between fill and natural ground. Actual slope will depend on compaction method used.
3. Extend gravel drain through compacted sloped ramp material to discharge under riprap.
4. Fill inlet area with embankment material compacted to 95% maximum density.

DATE AND TIME PLOTTED: 14-Nov-08 2:13 PM
 PLOTTED BY: SWINTERSON
 CAD SYSTEM: AUTOCAD 2005
 CAD FILENAME: I:\archive\0468_usda\0468-418-70-r1.dwg

REV NO 2008-1-14
 1 418 SMW Changed size of gabion plug to 3'x3'x3' and added upstream plug at inlet

ALWAYS THINK SAFETY

UNITED STATES
 DEPARTMENT OF THE INTERIOR
 BUREAU OF RECLAMATION
 PROVO AREA OFFICE
 PROVO, UTAH
BROWN DUCK BASIN LAKES
DAM STABILIZATION
 BROWN DUCK LAKE SPILLWAY MODIFICATION
 EXISTING OUTLET PROFILE

DESIGNED /s/ Scott Winterton, P.E. CHECKED /s/ Mike Talbot, P.E.
 DRAWN /s/ Dianne Loft TECH. APPR. /s/ Cary Southworth, P.E.
 APPROVED /s/ Clyde Thomas, P.E. PEER REVIEWER
 CLYDE THOMAS, P.E. - PEER REVIEWER
 PROVO, UTAH 2007-12-20

Appendix C - Inflow Hydrology Output Files

Dam Break Analysis Summary

	Spillway Floor Elev.	Bottom of Breach Elev.	Time to Breach (min.)	Dam Break Max. Flow (cfs)	Max. Depth in Channel (ft.)	Max. Depth at Moon L. (ft.)
Kidney	10,272	10,266	300	555	2.6	2.3
Island	10,249	10,242	300	496	2.6	2
Brown Duck	10,193.5	10,188	300	< 1	0.04	0.02
Clements	10,449	10,443	300	488	2.4	2.2

100 yr. Storm Spillway Hydraulics(CN=69)

	Flow in Spillway (cfs)**	Depth in Spillway (ft.)	Velocity in Spillway (ft.)
Island	128.00	1.12	6.4
Brown Duck	127.00	1.20	5.9

* **100-year, 6-hour, SCS Type III event

Appendix D – Construction Quantities

**Construction
Quantities**

	Outlet Channel Bottom Width*	Outlet Channel Elevation	Outlet Channel Excavation (cy)	Grout Volume, Outlet Pipe (cy)	Grout Volume, Gabion Baskets (cy)	Fill Volume, Inlet/Outlet (cy)	Riprap Removed from Dam (cy)	Riprap Placed in Breach (cy)	Riprap Volume, sill	Net Volume Cut (cy)
Island	15'	10,249	1,773	14	15	370	380	603	15	1,773
Brown Duck	15'	10,193.5	945	14.9	15	205	310	287	15	945

* 2.5:1 side slopes, both sides, finished width

**Total Bulk Amount of
Material Handled ****

Island	3,141 CY
Brown Duck	1,762 CY

** The sum of 'Fill Volume, Inlet/Outlet' + 'Riprap Removed from Dam' + 'Riprap Placed in Breach' + 'Riprap Volume, Sill' + 'Net Volume Cut'

Appendix E – Dam Break Output Files

Dam Break Scenarios

	Spillway Elevation	Excavation Elevation	Height to Breach	Dam Break Max. Flow (cfs)
Island	10248	10247	6	404
	10249	10248	7	496
	10250	10249	8	593
	10251	10250	9	694
Brown Duck	10191.5	10190.5	3.5	0
	10192	10191	4	0
	10193	10192	5	0
	10193.5	10192.5	5.5	0
	10194	10193	6	0
	10195	10194	7	0
	10196	10195	8	0
	10196.5	10195.5	8.5	178
	10197	10196	9	398
	10198	10197	10	476

High Lakes Stabilization Technical Memorandum

Timed Dam Break Scenarios

	Spillway Elevation	Excavation Elevation	Height to Breach	Dam Break Max. Flow (cfs)	Max. Depth in Channel (ft.)
Island					
100 min.	10248	10247	6	552	2.80
200 min.	10248	10247	6	452	2.60
300 min.	10248	10247	6	404	2.38
100 min.	10249	10248	7	686	3.00
200 min.	10249	10248	7	556	2.80
300 min.	10249	10248	7	496	2.60
100 min.	10250	10249	8	830	3.30
200 min.	10250	10249	8	667	3.00
300 min.	10250	10249	8	543	2.77
Brown Duck					
100 min.	10193	10192	5	0	0.08
200 min.	10193	10192	5	0	0.04
300 min.	10193	10192	5	0	0.03
100 min.	10193.5	10192.5	5.5	0	0.14
200 min.	10193.5	10192.5	5.5	0	0.06
300 min.	10193.5	10192.5	5.5	0	0.04
100 min.	10194	10193	6	1	0.20
200 min.	10194	10193	6	0	0.07
300 min.	10194	10193	6	0	0.05

Appendix F – Historical Drawings

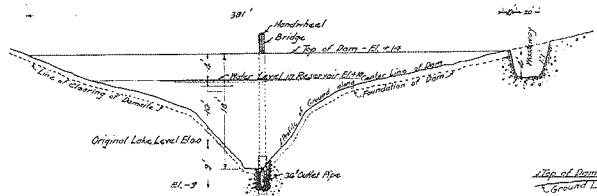

LONGITUDINAL SECTION OF DAM
Scale: Hor. 1/4"=50 Feet
Vert. 1/4"=10 Feet



CROSS SECTION OF WASTEWAY
Scale: 1/4"=10 Ft.

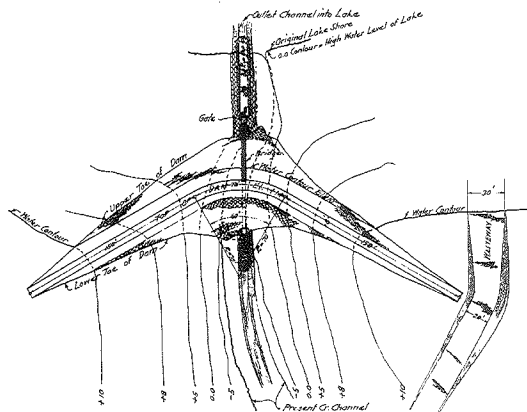

PLAN OF DAM
Scale: 1/4"=50 Feet

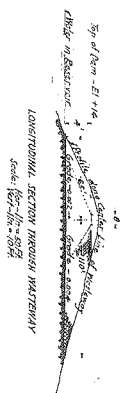

LONGITUDINAL SECTION THROUGH WASTEWAY
Scale: Hor. 1/4"=50 Feet
Vert. 1/4"=10 Feet

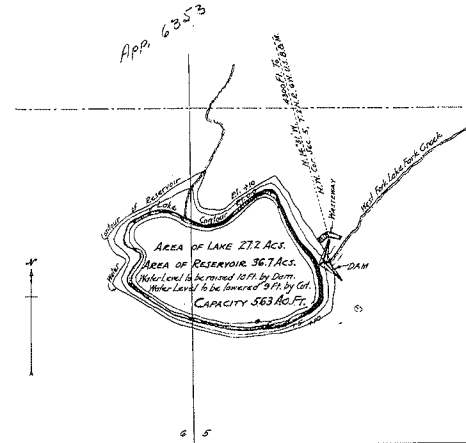

MAP OF RESERVOIR N°1
Scale: 1/4"=500 Feet

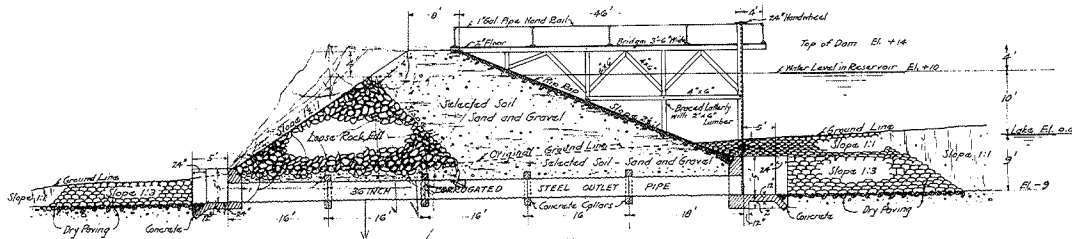

CROSS SECTION OF DAM
Scale: Hor. 1/4"=10 Feet
Vert. 1/4"=10 Feet

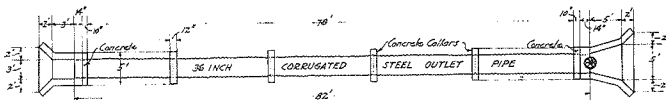

PLAN OF OUTLET
Scale: 1/4"=10 Ft.

FARMWORTH CANAL & RESERVOIR CO.
MAP OF RESERVOIR
AND DETAILS OF
DAM CONSTRUCTION

AT
RESERVOIR N°1
DUBOISIE CO. WYOM.
FEB-1917

Caldwell & Richards
ENGINEERS
Salt Lake City, Utah

Scales As Shown

SHEET N°1

Brown Duck Lake

32

1029 B

Received	3/18/17
Returned	
Approved	W. J. Jones
	State Engineer

TOWNSHIP 26 N. R. 32 E. S. 26

H 26

13
2
53

Brown Duck Lake

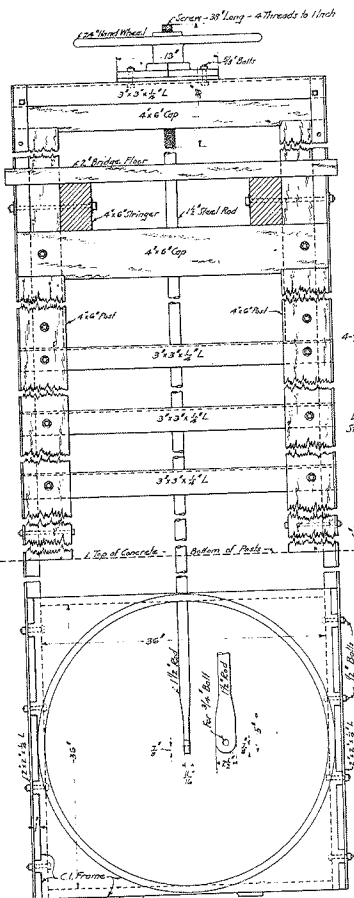

REAR ELEVATION

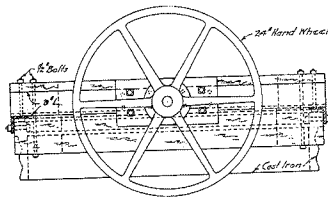

PLAN

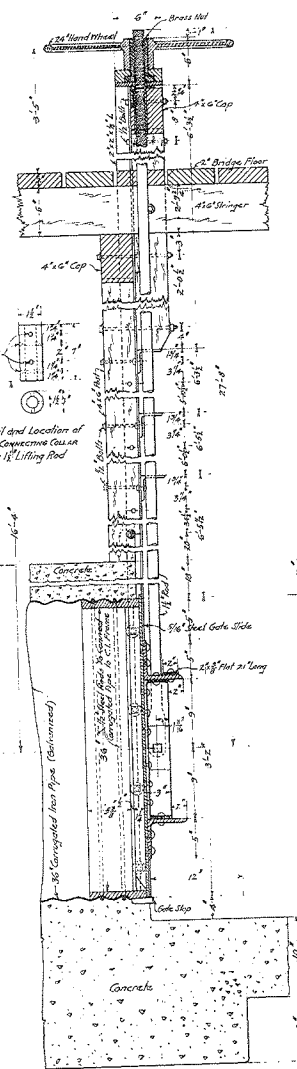

VERTICAL SECTION

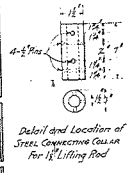

Detail and Location of Steel Connecting Collar for 1 1/2" Lifting Rod

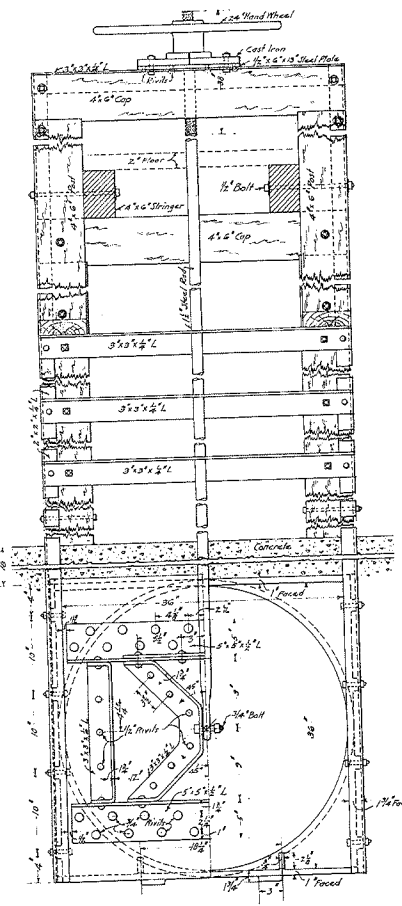

FRONT ELEVATION

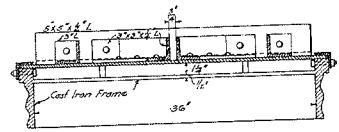

HORIZONTAL SECTION

FARNWORTH CANAL & RESERVOIR CO
 DETAILS OF
OUTLET GATES
 AT
 BROWN DUCK LAKE
 Scale: 1/2"=1'-0"

SHEET NO 2

13
 2
 52

Received *Brown Duck Lake*
 Feb. 9, 1917
 Returned
 Approved *Edw. J. Deane*
 State Engineer

31

1008 B Outlet
 UT 1917

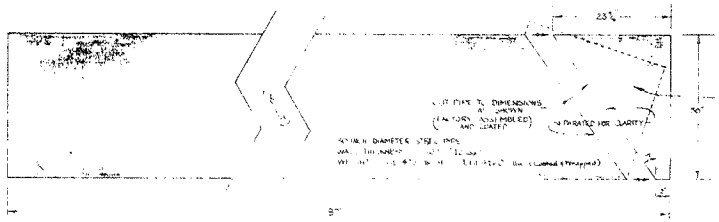

SECTION A-A
Scale 1" = 2'

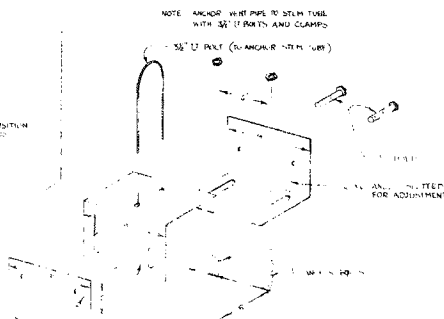

NOTE: ANCHOR VENT PIPE TO STEM TUBE WITH 3/8" BOLTS AND CLAMPS

NOTE: ALL METAL PARTS TO BE HOT DIP GALVANIZED OR PAINTED WITH ZINC RICH PRIMER PAINT

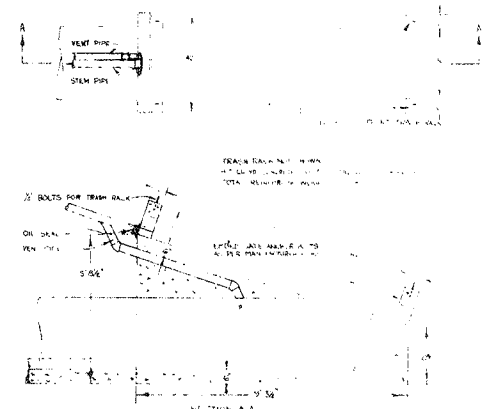

SECTION A-A
CONCRETE GATE STRUCTURE DETAIL 1
Scale 1" = 2'

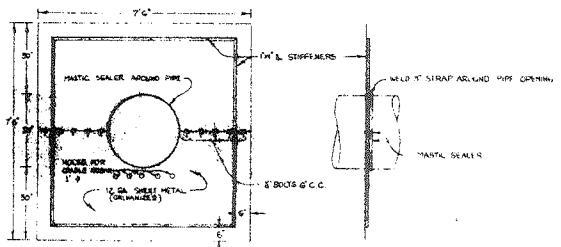

LOW ANTI-SEEP COLLARS WITH QUAL TIE ENAMEL
METAL ANTI-SEEP COLLAR DETAIL 2
Scale 1" = 2'

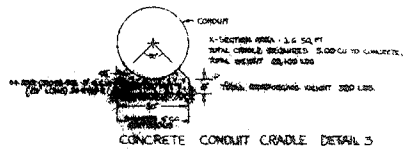

CONCRETE CONDUIT CRADLE DETAIL 3
Scale 1" = 2'

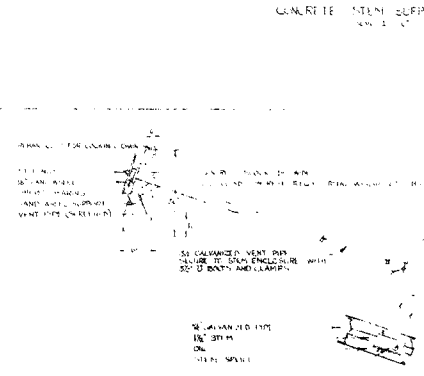

HAND WHEEL AND STEM DETAIL 4
Scale 1" = 2'

REINFORCING SCHEDULE

BAR NO.	BAR SIZE	NO. REQS.	TOTAL LENGTH	WELDED AT	BAR NO.	BAR SIZE	NO. REQS.	TOTAL LENGTH	WELDED AT
1	#4	2	8' 0"	1	5	#4	2	8' 0"	1
2	#4	2	8' 0"	1	6	#4	2	8' 0"	1
3	#4	2	8' 0"	1	7	#4	2	8' 0"	1
4	#4	2	8' 0"	1	8	#4	2	8' 0"	1
5	#4	2	8' 0"	1	9	#4	2	8' 0"	1
6	#4	2	8' 0"	1	10	#4	2	8' 0"	1
7	#4	2	8' 0"	1	11	#4	2	8' 0"	1
8	#4	2	8' 0"	1	12	#4	2	8' 0"	1
9	#4	2	8' 0"	1	13	#4	2	8' 0"	1
10	#4	2	8' 0"	1	14	#4	2	8' 0"	1

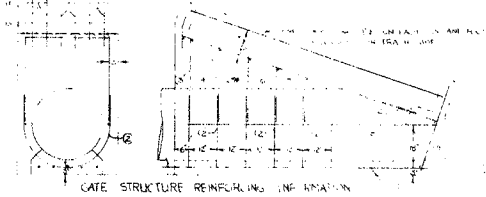

GATE STRUCTURE REINFORCING INFORMATION
Scale 1" = 2'

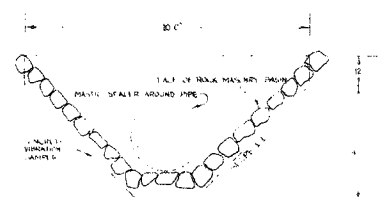

CONCRETE VIBRATION DAMPER DETAIL 5
Scale 1" = 2'

125 SQ. FT. DAMPER (BY 10' TOTAL WIDTH) (BY 12.5' TOTAL REINFORCING HEIGHT) (3' LB.)

DAMPER REINFORCING INFORMATION
Scale 1" = 2'

REINFORCING SCHEDULE

REINFORCING SCHEDULE

REINFORCING SCHEDULE

REVISIONS

NO.	DATE	DESCRIPTION
1	APRIL 1976	
2	MAY 14 1976	

BROWN DUCK LAKE
OUTLET CONDUIT REPLACEMENT

UNITED STATES WATER RESOURCES DIVISION
BUREAU OF RECLAMATION
DENVER, COLORADO

Utah Engineering & Land Surveying

DRAGON L. L. L. ENGINEERS ARCHITECTS
1000 WEST 10TH AVENUE
DENVER, COLORADO 80202

MICHAEL T. HARRIS, P.E. AS-EN
DANIEL R. HARRIS, P.E. AS-EN
JULY 1976

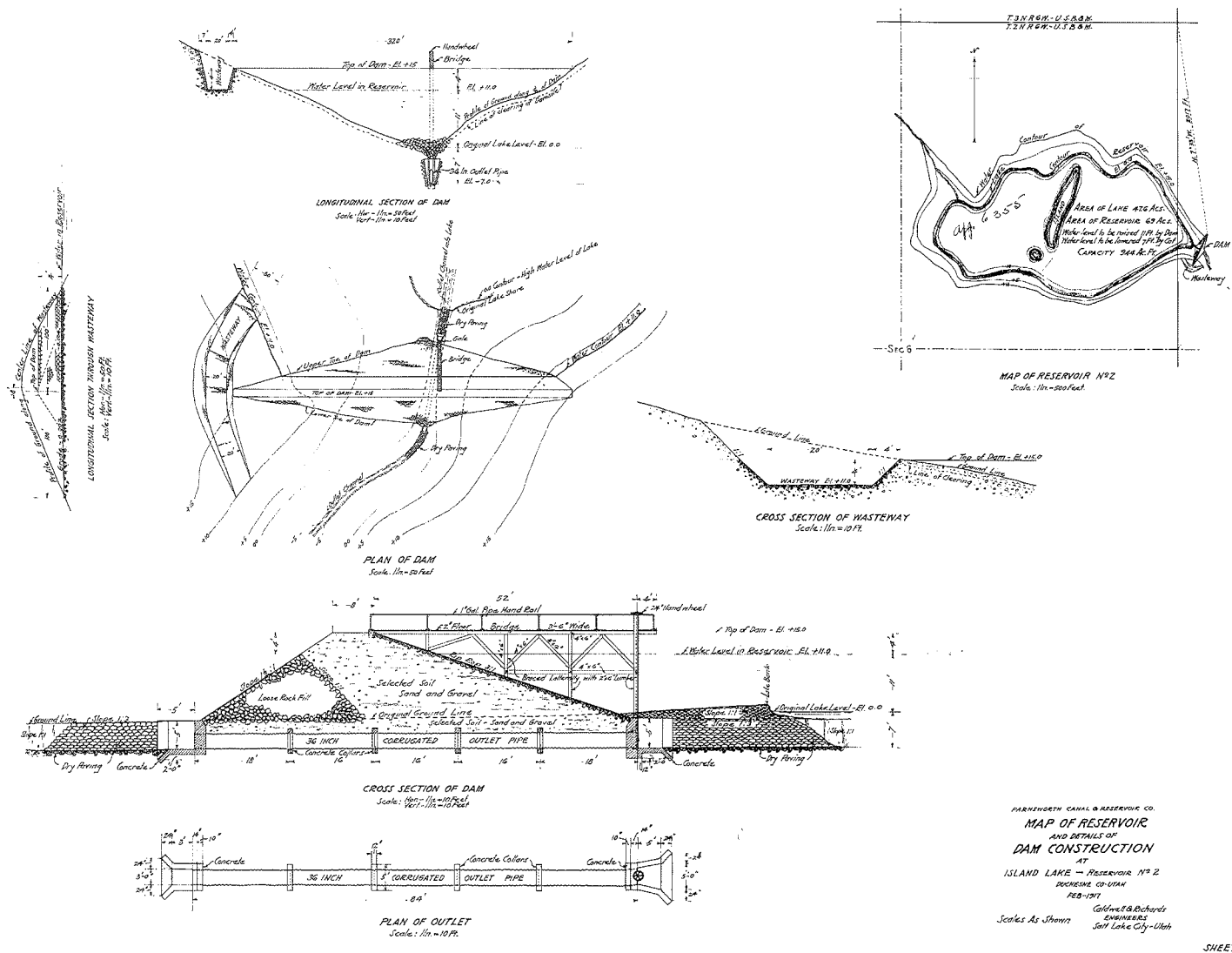

FARNHORTH CANAL & RESERVOIR CO.
**MAP OF RESERVOIR
 AND DETAILS OF
 DAM CONSTRUCTION**
 AT
 ISLAND LAKE - RESERVOIR NO. 2
 DOUGHERT CO. IOWA
 FEB-1911
 Colwell & Richards
 ENGINEERS
 Salt Lake City - Utah
 Scales As Shown

SHEET NO. 1

13
 2
 55

Received	2/8/17
Returned	
Approved	2/8/17

W. J. Jones
 State Engineer

28
 1028 B 26
 UT 146
 H-91

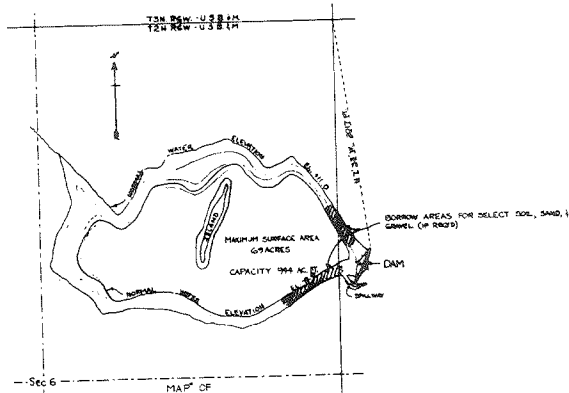

MAP OF ISLAND LAKE
Scale: 1 in = 500'

*From Caldwell & Sorenson, Feb 1917

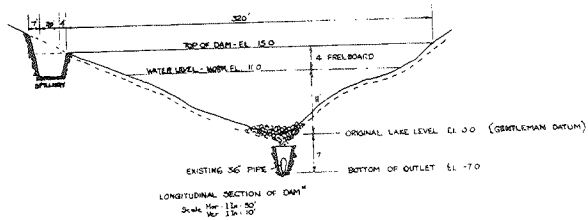

LONGITUDINAL SECTION OF DAM
Scale: 1 in = 50'

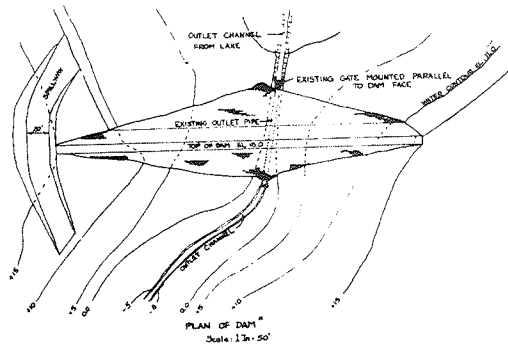

PLAN OF DAM
Scale: 1 in = 50'

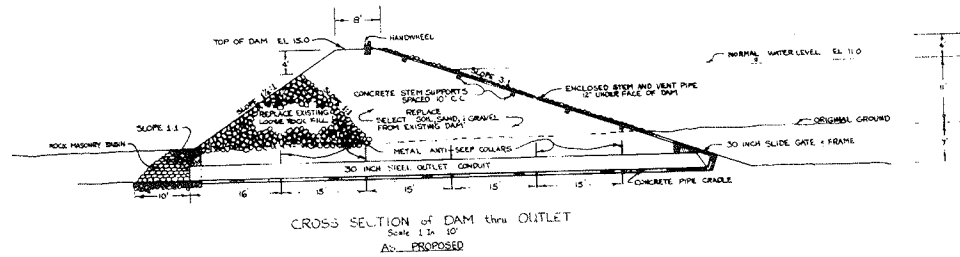

CROSS SECTION OF DAM thru OUTLET
Scale: 1 in = 10'
As PROPOSED

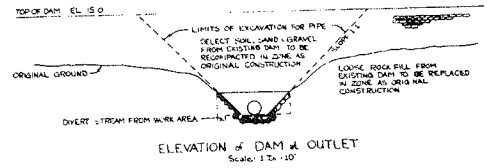

ELEVATION OF DAM & OUTLET
Scale: 1 in = 10'

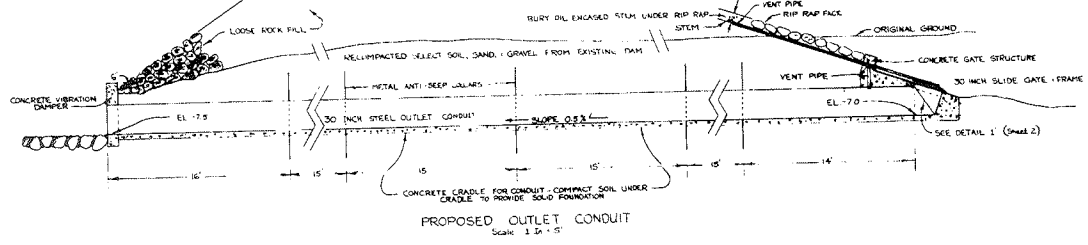

PROPOSED OUTLET CONDUIT
Scale: 1 in = 5'

APPROVED

Utah State Engineers: *[Signature]* Date: *1/1/76*
U.S. Forest Service: *[Signature]* Date: *4-22-76*
Moon Lake Water Users: _____ Date: _____



REVISIONS
OCT 3, 1975
OCT 30, 1975

ISLAND LAKE
OUTLET CONDUIT REPLACEMENT
MOON LAKE WATER USERS

SHEET 1
Utah Engineers & Land Surveying
CHARTERED 1892
MOON LAKE WATER USERS ASSN.
SCALE AS SHOWN
DATE: SEPT 15, 1975

