

# Guide for Module Developers

---

## Everything You Need to Know about Developing for EnergyPlus

(but were hesitant to ask)

Date: March 24, 2009

---

COPYRIGHT © 1998-2009 THE BOARD OF TRUSTEES OF THE UNIVERSITY OF ILLINOIS AND THE REGENTS OF THE UNIVERSITY OF CALIFORNIA THROUGH THE ERNEST ORLANDO LAWRENCE BERKELEY NATIONAL LABORATORY.  
ALL RIGHTS RESERVED. NO PART OF THIS MATERIAL MAY BE REPRODUCED OR TRANSMITTED IN ANY FORM OR BY ANY MEANS WITHOUT THE PRIOR WRITTEN PERMISSION OF THE UNIVERSITY OF ILLINOIS OR THE ERNEST ORLANDO LAWRENCE BERKELEY NATIONAL LABORATORY.  
ENERGYPLUS IS A TRADEMARK OF THE US DEPARTMENT OF ENERGY.



# TABLE OF CONTENTS

Introduction .....	1
Modules in EnergyPlus .....	2
What is a module anyway? .....	2
Program Modules .....	2
Data Only Modules .....	2
What is a module developer? .....	2
Input Concepts .....	3
Input Data Dictionary .....	3
Data Dictionary Naming Conventions .....	5
Class (Object) Names .....	5
Field Names .....	5
Choice Names .....	6
Input Data File .....	6
Input Considerations .....	8
Advanced Input Considerations .....	10
DataSets .....	11
Module Structure .....	12
Module Outline .....	12
Module Example .....	14
How it fits together .....	40
Top Level Calling Tree .....	40
High Level HVAC Calling Tree (schematic – not all routines are shown) .....	40
Air System Calling Tree (schematic – not all routines are shown) .....	41
Plant Supply Calling Tree (schematic – not all routines are shown) .....	42
Zone Equipment Calling Tree (schematic – not all routines are shown) .....	42
Inserting the New Module into the Program .....	43

# TABLE OF CONTENTS

Changing existing code.....	46
Considerations for Legacy Codes .....	46
Code Readability vs. Speed of Execution .....	46
Speed of Execution .....	47
EnergyPlus Services.....	49
Utility Routines/Functions.....	49
Table 1. Table of Utility Functions .....	49
Input Services .....	50
InputProcessor .....	51
GetNumObjectsFound .....	51
GetObjectItem .....	51
GetObjectDefMaxArgs .....	52
Extensible input techniques.....	52
GetObjectItemNum .....	52
FindItemInList.....	52
SameString .....	53
VerifyName .....	53
RangeCheck .....	53
MakeUPPERCase.....	54
Object Services.....	55
Branch & Node Checking and Services .....	59
BranchInputManager.....	59
NumBranchesInBranchList .....	59
GetBranchList .....	60
GetBranchData .....	60
NodeInputManager .....	61

# TABLE OF CONTENTS

Node Information Arguments .....	61
NodeFluidType .....	61
NodeObjectType.....	62
NodeObjectName .....	62
NodeConnectionType.....	62
NodeFluidStream.....	63
ObjectIsParent.....	64
GetOnlySingleNode .....	65
GetNodeNums .....	65
Unique Node Checking .....	66
InitUniqueNodeCheck .....	66
CheckUniqueNodes .....	66
EndUniqueNodeCheck.....	67
SetUpCompSets and TestCompSet .....	67
SetUpCompSets.....	68
TestCompSet.....	70
CheckOutAirNodeNumber .....	71
CheckAndAddAirNodeNumber .....	72
Schedule Services .....	72
GetScheduleIndex.....	73
GetDayScheduleIndex .....	74
CheckScheduleValueMinMax .....	74
CheckScheduleValue .....	74
GetScheduleMinValue .....	75
GetScheduleMaxValue .....	75
GetCurrentScheduleValue .....	75

# TABLE OF CONTENTS

GetScheduleValuesForDay .....	76
GetSingleDayScheduleValues .....	76
LookUpScheduleValue.....	76
Data Services.....	76
Global variable: MetersHaveBeenInitialized .....	76
GetMeterIndex .....	77
GetVariableKeyCountAndType .....	77
GetVariableKeys .....	77
GetCurrentMeterValue .....	78
GetInstantMeterValue .....	78
GetInternalVariableValue .....	78
Other Useful Utilities .....	78
GetNewUnitNumber .....	78
FindUnitNumber .....	79
FindNumberinList .....	79
ValidateComponent.....	79
CheckComponent .....	80
CreateSysTimeIntervalString .....	80
TrimSigDigits.....	81
RoundSigDigits .....	81
SafeDivide.....	82
Error Messages.....	82
Recurring Error Handling .....	84
Display Strings .....	85
Performance Curve Services .....	85
GetCurveIndex .....	86

# TABLE OF CONTENTS

GetCurveCheck.....	86
GetCurveType.....	86
CurveValue .....	87
Fluid Property Services.....	87
Using Fluid Property Routines in EnergyPlus Modules.....	87
Fluid Properties Functions for Refrigerant Class Fluids.....	88
Reference Data Set (RDS) Values for Refrigerant Class Fluids .....	88
Table 2. Regions for Fluid Properties .....	89
Fluid Property Data and Expanding the Refrigerants Available to EnergyPlus.....	89
Fluid Properties Functions for Glycol Class Fluids.....	92
Default Values for Glycol Class Fluids .....	92
Fluid Property Data and Expanding the Glycols Available to EnergyPlus.....	93
Weather Services.....	95
Global Data: Flags and Parameters.....	95
Parameters.....	95
Simulation Flags.....	96
Psychrometric services .....	97
PsyRhoAirFnPbTdbW (Pb,Tdb,W,calledfrom).....	98
PsyCpAirFnWTdb (W,Tdb,calledfrom).....	98
PsyHfgAirFnWTdb (W,Tdb,calledfrom).....	98
PsyHgAirFnWTdb (W,Tdb,calledfrom).....	98
PsyTdpFnTdbTwbPb (Tdb,Twb,Pb,calledfrom).....	98
PsyTdpFnWPb (W,Pb,calledfrom) .....	98
PsyHFnTdbW (Tdb,W,calledfrom) .....	98
PsyHFnTdbRhPb (Tdb,Rh,Pb,calledfrom).....	98
PsyTdbFnHW (H,W,calledfrom).....	99

# TABLE OF CONTENTS

PsyRhovFnTdbRh (Tdb,Rh,calledfrom) .....	99
PsyRhovFnTdbWP (Tdb,W,Pb,calledfrom) .....	99
PsyRhFnTdbRhov (Tdb,Rhov,calledfrom) .....	99
PsyRhFnTdbWPb (Tdb,W,Pb,calledfrom) .....	99
PsyTwbFnTdbWPb (Tdb,W,Pb,calledfrom) .....	99
PsyVFnTdbWPb (Tdb,W,Pb,calledfrom) .....	99
PsyWFnTdpPb (Tdp,Pb,calledfrom) .....	99
PsyWFnTdbH (Tdb,H,calledfrom) .....	99
PsyWFnTdbTwbPb (Tdb,Twb,Pb,calledfrom) .....	99
PsyWFnTdbRhPb (Tdb,Rh,Pb,calledfrom) .....	100
PsyPsatFnTemp (T,calledfrom) .....	100
PsyTsatFnHPb (H,Pb,calledfrom) .....	100
PsyTsatFnPb (P,calledfrom) .....	100
CPCW (Temp,calledfrom) .....	100
CPHW (Temp,calledfrom) .....	100
CVHW (Temp,calledfrom) .....	100
RhoH2O (Temp,calledfrom) .....	100
Tabular Output Utilities.....	100
WriteReportHeaders(reportName,objectName,averageOrSum).....	100
WriteSubtitle(subtitle) .....	101
WriteTable(body,rowLabels,columnLabels,widthColumn) .....	101
HVAC Network.....	102
Branches, Connectors, and Nodes .....	102
Figure 1. HVAC Input Diagram.....	102
Nodes in the simulation.....	105
Getting Nodes .....	107



# TABLE OF CONTENTS

Data Flow in an HVAC Component Module.....	107
Node Mass Flow Variables .....	110
Output .....	112
How Do I Output My Variables?.....	112
Table 3. SetupOutputVariable Arguments.....	113
Output Variable Dos and Don'ts.....	114
What Variables Should I Output?.....	114
Output Variable Naming Conventions.....	114
What are Meters?.....	115
How Do I Create A Meter? .....	115
Rules for Meter Variables.....	115
Running/Testing EnergyPlus – for Developers.....	117
DDOnly: Design Days Only .....	118
FullAnnualRun: Full Annual simulation.....	118
NoWeatherFile: Do not use weatherfile even if indicated.....	118
ReverseDD: Reverse Design Days during run.....	118
MinReportFrequency: Set minimum reporting frequency for outputs.....	118
Caution: Environment Variables .....	119
Air Loop Simulation.....	119
TRACK_AIRLOOP: Runtime performance tracker for air loop simulation .....	119
TRACE_AIRLOOP: Air loop simulation tracer.....	119
TRACE_HVACCONTROLLER: Individual HVAC controller tracer.....	119
Quick Procedure Outline For Making Code Changes to EnergyPlus.....	120
Important Rules for Module Developers.....	122
Appendix A. DataGlobals and DataEnvironments Modules.....	123
DataGlobals .....	123

# TABLE OF CONTENTS

DataEnvironment .....	123
Appendix B. Submissions and Check-ins .....	124
Appendix C. Documentation Specifics .....	128
Appendix D. Module, Subroutine, Function Templates .....	130
Appendix E. Test File Documentation .....	138
Appendix F. New or Changed Proposal Feature Template.....	139
Appendix G. ....	140

## Introduction

EnergyPlus is a modular simulation program designed to model the performance, energy consumption and pollutant production of a building. EnergyPlus models energy transport through the building envelope, heat gains within the building, and all the HVAC equipment used to heat and cool the building. The program is designed for ease of development. The concept is that many people will contribute to EnergyPlus and the program structure has been designed to make this possible.

EnergyPlus is written entirely in Fortran 90 with updates to Fortran 95 – all of EnergyPlus code should be at minimum Fortran 90 compliant and can accept the newer features of Fortran 95 as well. Fortran 90/95 is a powerful modern programming language with many features. Using Fortran 90/95 it is possible to program in many different styles. The EnergyPlus team has chosen a particular style that emphasizes code extensibility (ease of development), understandability, maintainability, and robustness. Less emphasis was placed on program speed and size. Fortran 90/95 has all the features that permit the creation of readable, maintainable, and extensible code. In particular, the ability to create data and program modules with various levels of data hiding allows EnergyPlus to be built out of semi-independent modules. This allows a new EnergyPlus developer to concentrate on programming a single component without having to learn the entire program and data structure.

The EnergyPlus programming style is described in the *EnergyPlus Programming Standard*. The *Programming Standard* should be consulted for details such as variable and subroutine naming conventions. In this document, we will describe the steps a developer must follow to create a new EnergyPlus component model. In particular, we will assume the developer wishes to simulate an HVAC component that cannot yet be modeled by EnergyPlus.

## Modules in EnergyPlus

### What is a module anyway?

#### Program Modules

A module is a Fortran 90/95 programming construct that can be used in various ways. In EnergyPlus, its primary use is to segment a rather large program into smaller, more manageable pieces. Each module is a separate package of source code stored on a separate file. The entire collection of modules, when compiled and linked, forms the executable code of EnergyPlus.

Each module contains source code for closely related data structures and procedures. For instance, the WeatherManager module contains all the weather handling routines in EnergyPlus. The module is contained in the file WeatherManager.f90. Another example is PlantPumps. This module contains all the code to simulate pumps in EnergyPlus. It is contained in file PlantPumps.f90.

Of course dividing a program into modules can be done in various ways. We have attempted to create modules that are as self-contained as possible. The philosophy that has been used in creating EnergyPlus is contained in the [Programming Standard](#) reference document. Logically, the modules in EnergyPlus form an inverted tree structure. At the top is EnergyPlus. Just below that are ProcessInput and ManageSimulation. At the bottom are the modules such as HVACDamperComponent that model the actual HVAC components.

#### Data Only Modules

EnergyPlus also uses modules that contain only data. These modules form one of the primary ways data is structured and shared in EnergyPlus. An example is the DataEnvironment module. Many parts of the program need access to the outdoor conditions. All of that data is encapsulated in DataEnvironment. Modules that need this data obtain access through a Fortran USE statement. Without such access, modules cannot use or change this data.

### What is a module developer?

A module developer is someone who is going to add to the simulation capabilities of EnergyPlus. Someone, for instance, who is interested in adding code to model a new type of HVAC equipment. The most straightforward way of doing this is to create a new program module – hence the term “module developer”. Another kind of module developer would be the adaptation of an existing “legacy” code to EnergyPlus.

In EnergyPlus, the first step in creating a new component model is to define the input. So, before we discuss modules in more detail, we must first describe the EnergyPlus input.

## Input Concepts

In EnergyPlus, input and output are accomplished by means of ASCII (text) files. On the input side, there are two files:

- 1) the Input Data Dictionary (IDD) that describes the types (classes) of input objects and the data associated with each object;
- 2) the Input Data File (IDF) that contains all the data for a particular simulation.

Each EnergyPlus module is responsible for getting its own input. Of course, EnergyPlus provides services to the module that make this quite easy. The first task of a module developer is to design and insert a new entry into the Input Data Dictionary.

### Input Data Dictionary

An entry in the IDD consists of comma-separated text terminated by a semicolon. For instance:

```
Coil:Heating:Water,
  \min-fields 14
A1 , \field Name
  \required-field
  \type alpha
  \reference HeatingCoilName
  \reference HeatingCoilsWater
A2 , \field Availability Schedule Name
  \type object-list
  \object-list ScheduleNames
N1 , \field U-Factor Times Area Value
  \units W/K
  \autosizable
  \default Autosize
N2 , \field Maximum Water Flow Rate
  \units m3/s
  \autosizable
  \ip-units gal/min
  \default Autosize
A3 , \field Water Inlet Node Name
  \required-field
A4 , \field Water Outlet Node Name
  \required-field
A5 , \field Air Inlet Node Name
  \required-field
A6 , \field Air Outlet Node Name
  \required-field
A7 , \field Performance Input Method
  \type Choice
  \key UFactorTimesAreaAndDesignWaterFlowRate
  \key NominalCapacity
  \default UFactorTimesAreaAndDesignWaterFlowRate
N3 , \field Nominal Capacity
  \type real
  \units W
  \autosizable
  \minimum 0
  \default Autosize
N4 , \field Design Inlet Water Temperature
  \units C
```

```

        \type real
        \default 82.2
N5, \field Design Inlet Air Temperature
    \units C
        \type real
        \default 16.6
N6, \field Design Outlet Water Temperature
    \units C
        \type real
        \default 71.1
N7; \field Design Outlet Air Temperature
    \units C
        \type real
        \default 32.2

```

This entry defines a simple water-heating coil and specifies all of the input data needed to model it. The following rules apply.

- The first element Coil:Heating:Water is the class name (also called a keyword or key). This class name must be unique in the IDD. The maximum length for the class name is 100 characters. Embedded spaces are allowed and are significant.
- In most cases, one should have fields following the object name. An object name by itself (terminated with a semicolon) is a “section” – there may be uses for sections in input but the “Getting” of input is not hierarchical – one typically gets all objects of one type and then all objects of the next type.
- In most cases, the second field of an object should be an “alpha” and the field name should contain the word “name”. (This will allow for certain validations later on.)
- Commas separate fields. They always act as separators – thus there is no way to include a comma in a class name or as part of a data field.
- Similarly, semicolons are terminators – a semicolon is always interpreted as the end of an EnergyPlus “sentence”. So, avoid embedded semicolons in class names or data fields.
- Blank lines are allowed.
- Each line can be up to 500 characters in length.
- The comment character is an exclamation or a backslash. Anything on a line after an “!” or a “\” is ignored during EnergyPlus input.

The only significant syntax elements are the commas, the semicolon, the N’s (denoting numeric data), and the A’s (denoting alphanumeric data) and the exclamation and backslash. Everything else including blanks, end of lines, or even text that is not a comma, semicolon, N, or A is ignored. There are several style conventions in use however.

- Sequence numbers are appended to the letters A or N denoting each data element. Thus, A2 is the second alphanumeric data item and N3 is the third numeric data item.
- The class name contains a naming convention: type:subtype:subsubtype. For further naming conventions, please see the next section of this document.

- Backslashes denote specially formatted comments. These comments provide information about the input, such as a description of the item, units, limits, mins & maxes, etc., in a form that can be processed by an input editor or interface. A complete description of the backslash comment format is given at the start of the IDD file and in the Guide for Interface Developers. While these are “comments”, they are quite important and allow the InputProcessor module to do some error checking for you. They are also used by the IDFEditor that many users continue to use and by interface developers in understanding EnergyPlus.
  - **\default** – the number (N fields) or phrase (A fields) after this special field will be filled for any input file that has a blank in that field.
  - **\minimum** or **\minimum>** -- the number following this special field will be automatically checked during input
  - **\maximum** or **\maximum<** -- the number following this special field will be automatically checked during input
  - **\extensible:#** – allows you to structure your GetInput routine so that the object arguments can be expanded (you include the number of fields in the “extension” and the Input Processor can automatically extend IDD definitions) – you will still need to determine how many maximum arguments are in the object.
  - **\type integer** – (or **real** or **alpha**) – this field has gained increased importance after a user kept hitting an internal maximum detected by the program and kept increasing their input number until it overflowed the system’s integer size. Until all types are shown on numeric fields it will be hard for the InputProcessor to provide proper error detection.

Overall, the IDD file has very little structure. Generally, a new entry should be placed next to entries describing similar components. *Coil:Heating:Water*, for instance, is grouped with entries describing other water coils.

### Summary

One of the early tasks for a module developer is to create a new entry in the Input Data Dictionary. This entry defines the data needed to model the new component.

## Data Dictionary Naming Conventions

### Class (Object) Names

Class names shall be written in camel case where words are joined together without spaces and each word is capitalized. The colon shall be used to delimit hierarchy moving from general to specific. Natural language terminology shall be used when possible for each member separated by colons.

Example: `ZoneHVAC:PackagedTerminalHeatPump`

### Field Names

Field names shall be written in title case where every major word is capitalized (exceptions: "a", "the", "for", etc.) with spaces separating words. Field names shall be written using natural language terminology but should be relatively concise (no unnecessary abbreviations or acronyms). If the field is for the name of this object, the field name shall simply be "Name" to

eliminate redundancy. The nature of an alpha field shall be explicit, for instance, "Availability Schedule Name" instead of merely "Availability Schedule". Generally, the object is not also included as the field name.

Example: Availability Schedule Name

When object names/types are included as part of the input, then the field name should contain "Object Type":

Example: Zone Equipment 1 Object Type

### Choice Names

When field choices list object references, the field choices shall list the class/object type name the same as its class definition in the IDD. When field choices list other key words, the field choice names shall be written in camel case where words are joined together without spaces and each word is capitalized. Field choice names shall be written using natural language terminology but should be relatively concise (no unnecessary abbreviations or acronyms) and avoid overly lengthy key words. Field choice names shall only use alphanumeric characters with the addition of the forward slash ("/") character as a concise alternative to the word "per"; colons shall be allowed if the field choices are class names.

```
A2 , \field Period Selection
      \retaincase
      \note Following is a list of all possible types of Extreme and Typical periods
that
      \note might be identified in the Weather File. Not all possible types are
available
      \note for all weather files.
      \type choice
      \key SummerExtreme
      \key SummerTypical
      \key WinterExtreme
      \key WinterTypical
      \key AutumnTypical
      \key SpringTypical
      \key WetSeason
      \key DrySeason
      \key NoDrySeason
      \key NoWetSeason
      \key TropicalHot
      \key TropicalCold
```

### Input Data File

The Input Data File (IDF) is the file containing the data for an actual simulation. This file is also a text (ASCII) file with a syntax "filling in the blanks" of the definitions in the IDD. A portion of an IDF with input data for the hot water coil defined in the IDD example looks like:



```

Coil:Heating:Water,
  SPACE1-1 Zone Coil,          !- Name
  ReheatCoilAvailSched,      !- Availability Schedule Name
  autosize,                  !- U-Factor Times Area Value {W/K}
  autosize,                  !- Maximum Water Flow Rate {m3/s}
  SPACE1-1 Zone Coil Water In Node, !- Water Inlet Node Name
  SPACE1-1 Zone Coil Water Out Node, !- Water Outlet Node Name
  SPACE1-1 Zone Coil Air In Node, !- Air Inlet Node Name
  SPACE1-1 In Node,          !- Air Outlet Node Name
  UFactorTimesAreaAndDesignWaterFlowRate, !- Performance Input Method
  autosize,                  !- Nominal Capacity {W}
  82.2,                      !- Design Inlet Water Temperature {C}
  16.6,                      !- Design Inlet Air Temperature {C}
  71.1,                      !- Design Outlet Water Temperature {C}
  32.2;                      !- Design Outlet Air Temperature {C}

Coil:Heating:Water,
  SPACE2-1 Zone Coil,          !- Name
  ReheatCoilAvailSched,      !- Availability Schedule Name
  autosize,                  !- U-Factor Times Area Value {W/K}
  autosize,                  !- Maximum Water Flow Rate {m3/s}
  SPACE2-1 Zone Coil Water In Node, !- Water Inlet Node Name
  SPACE2-1 Zone Coil Water Out Node, !- Water Outlet Node Name
  SPACE2-1 Zone Coil Air In Node, !- Air Inlet Node Name
  SPACE2-1 In Node,          !- Air Outlet Node Name
  UFactorTimesAreaAndDesignWaterFlowRate, !- Performance Input Method
  autosize,                  !- Nominal Capacity {W}
  82.2,                      !- Design Inlet Water Temperature {C}
  16.6,                      !- Design Inlet Air Temperature {C}
  71.1,                      !- Design Outlet Water Temperature {C}
  32.2;                      !- Design Outlet Air Temperature {C}

Coil:Heating:Water,
  SPACE3-1 Zone Coil,          !- Name
  ReheatCoilAvailSched,      !- Availability Schedule Name
  autosize,                  !- U-Factor Times Area Value {W/K}
  autosize,                  !- Maximum Water Flow Rate {m3/s}
  SPACE3-1 Zone Coil Water In Node, !- Water Inlet Node Name
  SPACE3-1 Zone Coil Water Out Node, !- Water Outlet Node Name
  SPACE3-1 Zone Coil Air In Node, !- Air Inlet Node Name
  SPACE3-1 In Node,          !- Air Outlet Node Name
  UFactorTimesAreaAndDesignWaterFlowRate, !- Performance Input Method
  autosize,                  !- Nominal Capacity {W}
  82.2,                      !- Design Inlet Water Temperature {C}
  16.6,                      !- Design Inlet Air Temperature {C}
  71.1,                      !- Design Outlet Water Temperature {C}
  32.2;                      !- Design Outlet Air Temperature {C}

```

Each coil entry begins with the class name (keyword) specifying the type of coil. Next is the coil name – a user (or interface) created name that is unique within the given class. Generally in EnergyPlus, objects within a class are distinguished by unique names. The object name is usually the first data element following the class name. Any alphanumeric data item in the IDF can be up to 100 characters long. Any characters past 100 are truncated (lost). After the object name comes the real data. If we look at the IDD we see that the first data item after the object name is expected to be an alphanumeric – a schedule name. In the IDF, we see the corresponding field is “ReheatCoilAvailSched”, the object name of a schedule elsewhere in the IDF file. In EnergyPlus, all references to other data entries (objects) are via

object names. The next two data items are numeric: the coil UA and the maximum water mass flow rate. The final four items are again alphanumeric – the names of the coil inlet and outlet nodes. Nodes are used in EnergyPlus to connect HVAC components together into HVAC systems.

The example illustrates the use of comments to create clear input. The IDF is intended to be human readable, largely for development and debugging purposes. Of course, most users will never see an IDF – they will interact with EnergyPlus through a Graphical User Interface (GUI), which will write the IDF for them. However, a module developer is a special kind of user. The module developer will need to create a portion of an IDF by hand very early in the development process in order to begin testing the module under development. Thus, it is important to understand the IDF syntax and to use comments to create readable test IDF files.

### Summary

One of the early tasks of a module developer is to create input (most likely by hand) for the new component and to insert it into an existing IDF file in order to test the new component model. The IDF syntax resembles the syntax for the IDD. The data follows the IDD class description. Comments should be used to make the IDF readable.

## Input Considerations

The IDD/IDF concept allows the module developer much flexibility. Along with this flexibility comes a responsibility to the overall development of EnergyPlus. Developers must take care not to obstruct other developers with their additions or changes. Major changes in the IDD require collaboration among the developers (both module and interface).

In many cases, the developer may be creating a new model – a new HVAC component, for instance. Then the most straightforward approach is to create a new object class in the IDD with its own unique, self-contained input. This will seldom impact other developers.

In some cases, the developer may be adding a calculation within an existing module or for an existing class of objects. This calculation may require new or different input fields. Then the developer has a number of choices. This section will present some ideas for adding to the IDD that will minimize impact to other developers.

For example, consider the implementation of Other Side Coefficients (OSC) in the IDD. Other side coefficients are a simplification for the surface heat balance and were used mostly in BLAST 2.0 before we had interzone surfaces. We have carried this forward into EnergyPlus for those users that understand and can use it. We'll use it as an example of approaches to adding data items to the IDD. Moreover, we'll try to give some hints on which approaches might be used for future additions.

So, you're adding something to EnergyPlus and it is part of an existing module or object class. What do you do with your required inputs to your model? There are at least four options:

- Embed your values in a current object class definition.
- Put something in the current definition that will trigger a "GetInput" for your values.

- Put something in the current definition that will signal a "special" case and embed a name (of your item) in the definition (this adds 1 or 2 properties to the object).
- Just get your input and have each of those inputs reference a named object.

For example, using the OSC option in surfaces, in the beta 2 version of EnergyPlus we had

```
A8 , \field Exterior environment
    \type alpha
    \note <for Interzone Surface:Adjacent surface name>
    \note For non-interzone surfaces enter:
    \note ExteriorEnvironment, Ground, or OtherSideCoeff
    \note OSC won't use CTFs

N24, \field User selected Constant Temperature
N25, \field Coefficient modifying the user selected constant
      temperature
N26, \field Coefficient modifying the external dry bulb temperature
N27, \field Coefficient modifying the ground temperature
N28, \field Combined convective/radiative film coefficient
    \note if=0, use other coefficients
N29, \field Coefficient modifying the wind speed term (s/m)
N30, \field Coefficient modifying the zone air temperature part of
      the equation
```

**1)** We have done option 1: embed the values in the input. (We have also embedded these values in each and every surface derived type (internal data structure) but that can be discussed elsewhere).

When to use: It makes sense to embed these values when each and every object (SURFACE) needs these values (e.g. we need to specify Vertices for Every Surface -- so these clearly should be embedded).

After beta 2, the definition of Surfaces was changed. Obviously option 1 was not a good choice for the OSC data: the data would be rarely used. Our other options were:

**2)** Obviously the ExteriorEnvironment field will remain (but its name was changed to Outside Face Environment).

However, we do not want to embed the values for OtherSideCoef in the Surface items. So, if the ExteriorEnvironment continues to reference OtherSideCoef, we can easily trigger a "GetInput" for them. An additional object class would be necessary for this case.

```
OtherSideCoef, A1, \field name of OtherSideCoef,
  A2, \field SurfaceName (reference to surface using OSC)
  ....
```

When to use: This option can be used for many cases. The same object definition will work for option 4 below. Obviously, if there is not a convenient trigger in SURFACE but you want to add a feature, this would let you do it without embedding it in the Surface Definition. If there is a trigger, such as exists with the ExteriorEnvironment, the A2 field might not be needed. This approach would become a bit cumbersome if you expected there to be a lot of these or if there were a one-to-many relationship (i.e. a single set of OSCs could be used for many surfaces). Nevertheless, the approach provides a convenient "data check"/cross reference that can be validated inside the code.

3) We could also have the SURFACE definition reference an OSC name (in this instance).

So, we'd add a field to the Surface that would be the name in the OtherSideCoef object above. Then, the OtherSideCoef objects wouldn't need a Surface Name. This is the most straightforward approach: including data in one object by referencing another and it was the approach chosen for the redefined Surface class.

When to use: when there is a set of parameters that would be used extensively, then this would provide a name for those. If hand editing, then you only would need to change one set of these parameters rather than having to go through many. Of course, the OtherSideCoef object wouldn't also have to have the true numbers but could reference yet a third named object..... (starting to get messy).

4) We could have the OtherSideCoef object as above and just "get" it as a matter of course. (e.g., in the case where we don't have a convenient trigger such as ExteriorEnvironment).

When to use: Note that the same structure for 2 works here too. It's just not triggered (to get the input) by a value in the other object (SURFACE).

### Summary

There are several approaches to adding items to the IDD. Developers need to consider impacts to other developers and users early in the implementation planning.

## Advanced Input Considerations

Creating a new module/adding a new feature to EnergyPlus is a good accomplishment. However, it is likely that future additions will be done and will impact any objects created. In this regard, we ask that module developers take a longer view than "just getting my thing" going.

For example, in the "Fan Coil" object, prior to the V1.2 release, the object definition specified a cooling coil name. *But it did not specify a cooling coil type.* Rather than restrict coil names to be unique over all coils (which becomes difficult as more coil types are added), the developers only have unique names within a type. Thus, it would become difficult for the Fan Coil module to get the proper link to the correct cooling coil.

In the V1.2 release, a cooling coil type was added to the object. But the resulting object is less readable now. For upwards compatibility, the coil type was placed at the end of the object whereas the coil name is in the middle. If this had been thought of earlier, then the coil type and coil name could be in succeeding fields in the object definition.

The "standard" for describing such fields would be to list the "coil type" and then the "coil name" fields, such as in the UNITARYSYSTEM:HEATPUMP:AIRTOAIR object.

The point – try to envision future changes in making up objects, even if you think "that will never happen". You do not have to try to address every future case, only the most likely.

```

FAN COIL UNIT:4 PIPE,
  \min-fields 21
A1 , \field name of fan coil unit
  \required-field
A2 , \field availability schedule
  \required-field
  \type object-list
  \object-list ScheduleNames
N1 , \field maximum air flow rate
  \required-field
  \autosizable
  \units m3/s
N2 , \field maximum outside air flow rate
  \required-field
  \autosizable
  \units m3/s
A3 , \field air inlet node
  \required-field
<snip>
A11, \field cooling coil name
  \required-field
N3 , \field maximum cold water flow
  \required-field
  \autosizable
  \units m3/s
  \ip-units gal/min
<snip>
A13; \field Cooling coil type
  \required-field
  \type choice
  \key COIL:Water:SimpleCooling
  \key COIL:Water:DetailedFlatCooling
  \key COIL:Water:CoolingHeatExchangerAssisted

```

## DataSets

Akin to the libraries of other programs, EnergyPlus uses data sets. Data sets are similar to libraries but many items are contained in a single file (usually input file format or sometimes macro format). Developers are encouraged, as appropriate, to submit data sets along with new features. Some of the existing data sets include:

- Materials properties
- Construction elements (layers of materials)
- Composite construction definitions (equivalent constructions for complex elements)
- Solar Collector parameters
- Economic Tariffs
- Design Day definitions
- Location definitions
- Standard report definitions

## Module Structure

Let us assume that the novice EnergyPlus developer wishes to model a new HVAC component called *NewHVACComponent*. Right at the start there is a choice to make: whether to insert the new model into an existing module or to create an entirely new EnergyPlus component simulation model. Creating a new module is the easier option to explain, implement and test. We will discuss this option in this document. The discussion should also impart enough information to allow a new developer to insert a model into an existing EnergyPlus module if that option is chosen.

If you intend that the module will become part of the distributed EnergyPlus, follow the guidance in the Programming Standard document. Even if you don't intend that your module will become part of EnergyPlus – but you might want some advice from one of the core development team, follow the guidance in the Programming Standard.

### Module Outline

The developer will create a new file `NewHVACComponent.f90`. The file shall contain the following elements:

Note – even if your component does not need some of the suggested modules, you should include “stub” routines for these.

#### **MODULE** NewHVACComponent

**Documentation:** Fortran comments describing and documenting the module. Included are sections showing module author, module creation date, date modified and modification author. Each routine and/or function should also follow the documentation guidelines as shown in the templates.

**USE Statements:** Fortran statements naming other modules that this module can access, either for data or for routines.

**Module Parameters:** If you will be implementing more than one “type” of component in the module, it is a good idea to assign numeric parameters to each type so as to retain readability yet reduce alpha comparisons which are notoriously slow for most systems. Assign numeric parameters to alphanumeric fields within a class type (.e.g. object UnitarySystem:HeatPump, field Fan Placement: “blow through” or “draw through”) when this information is required in init, calc, update or report subroutines to further reduce alpha comparisons. Use string comparison only in GetInput subroutines.

**Module Data structure Definitions:** Using the Fortran TYPE statement define the data structures needed in the module that will not be available from other modules. Define all module level variables that will be needed.

Typically, you define your module's data structure within the module. If this data must be used by multiple modules, you should define a separate Data module for the data.

**Character strings in structures are not allowed (except for name of object) – any exceptions must be approved. Schedule names, curve object names, and child object types MUST all be referenced by an integer.**

For existing code, convert all character string structure variables to integer parameters and delete the character variable from the structure. Also delete unused strings rather than converting to integer. Do not use structure variable to store information used only during GetInput even if you think it could be used in the future, use local variables instead. Usually won't hurt anything until some user puts a large number of objects in their input (memory use impact).

Currently, the furnace structure includes many that should not be there. SuppHeatCoilType is an example of a character string structure variable that is only used in GetInput and is not needed in the structure. Should have been a local instead. And CoolingPLFFPLR and HeatingPLFFPLR structure variables are not even used.

### **CONTAINS**

#### ***SUBROUTINE SimNewHVACComponent***

This routine selects the individual component being simulated and calls the other module subroutines that do the real work. This routine is the only routine in the module that is accessible outside the module (*PUBLIC*). All other routines in the module are *PRIVATE* and are only callable within the module. This routine is sometimes called the "driver" routine for the module.

#### ***END SUBROUTINE SimNewHVACComponent***

#### ***SUBROUTINE GetNewHVACComponentInput***

This routine uses the "get" routines from the InputProcessor module to obtain input for NewHVACComponent. The module data arrays are allocated and the data is moved into the arrays.

#### ***END SUBROUTINE GetNewHVACComponentInput***

#### ***SUBROUTINE InitNewHVACComponent***

This routine performs whatever initialization calculations that may be needed at various points in the simulation. For instance, some calculations may only need to be done once; some may need to be done at the start of each simulation weather period; some at the start of each HVAC simulation time step; and some at the start of each loop solution. This routine also transfers data from the component inlet nodes to the component data arrays every time the component is simulated, in preparation for the actual component simulation.

#### ***END SUBROUTINE InitNewHVACComponent***

#### ***SUBROUTINE SizeNewHVACComponent***

This routine can create the sizing options (if applicable) for the component or be left as a placeholder for later manipulation for sizing purposes.

#### ***END SUBROUTINE SizeNewHVACComponent***

#### ***SUBROUTINE CalcNewHVACComponent***

This routine does the actual calculations to simulate the performance of the component. Only calculation is done – there is no moving of data from or to input or output areas. There may be more than one "CALC" subroutine if more than one component is being modeled within this module.

#### ***END SUBROUTINE CalcNewHVACComponent***

#### ***SUBROUTINE UpdateNewHVACComponent***

This routine moves the results of the "Calc" routine(s) to the component outlet nodes.

#### ***END SUBROUTINE UpdateNewHVACComponent***

***SUBROUTINE ReportNewHVACComponent***

This routine performs any special calculations that are needed purely for reporting purposes.

***END SUBROUTINE ReportNewHVACComponent***

***Utility Routines (as appropriate) – in the Fan module we allow outside modules to access internal fan inlets, outlets, and design volume flow rate.***

***END MODULE NewHVACComponent*****Module Example**

This example can be used as a template for new HVAC component modules. In particular, the commenting structure in the module and within the subroutines should be followed closely. Of course, there is no perfect example module – this one is particularly simple. Some others that might be examined are in files Humidifiers.f90, HVACHeatingCoils.f90 and PlantChillers.f90. Templates are also available as separate files.

In particular, the module template with routines contains structure and information pertinent to module development.

Note that in the following module, the “Data IPShortcuts” is not used – rather those variables are allocated within this module – likely because another module calls this one during input.

```

Module Fans
! Module containing the fan simulation routines

! MODULE INFORMATION:
!   AUTHOR      Richard J. Liesen
!   DATE WRITTEN April 1998
!   MODIFIED    Shirey, May 2001
!   RE-ENGINEERED na

! PURPOSE OF THIS MODULE:
! To encapsulate the data and algorithms required to
! manage the Fan System Component

! REFERENCES: none

! OTHER NOTES: none

! USE STATEMENTS:
! Use statements for data only modules
USE DataPrecisionGlobals
USE DataLoopNode
USE DataHVACGlobals, ONLY: TurnFansOn, TurnFansOff, Main, Cooling, Heating, Other, &
    OnOffFanPartLoadFraction, SmallAirVolFlow, UnbalExhMassFlow, NightVentOn, cFanTypes, &
    FanType_SimpleConstVolume, FanType_SimpleVAV, FanType_SimpleOnOff, FanType_ZoneExhaust
USE DataGlobals, ONLY: SetupOutputVariable, BeginEnvrnFlag, BeginDayFlag, MaxNameLength, &
    ShowWarningError, ShowFatalError, ShowSevereError, HourOfDay, SysSizingCalc, CurrentTime, &
    OutputFileDebug, ShowContinueError, ShowRecurringWarningErrorAtEnd, WarmupFlag, &
    ShowContinueErrorTimeStamp
USE DataEnvironment, ONLY: StdBaroPress, DayOfMonth, Month, StdRhoAir
USE Psychrometrics, ONLY: PsyRhoAirFnPbTdbW, PsyTdbFnHW, PsyCpAirFnWTdb

! Use statements for access to subroutines in other modules
USE ScheduleManager

IMPLICIT NONE          ! Enforce explicit typing of all variables

PRIVATE ! Everything private unless explicitly made public

```



```

!MODULE PARAMETER DEFINITIONS
!na

! DERIVED TYPE DEFINITIONS
TYPE FanEquipConditions
  CHARACTER(len=MaxNameLength) :: FanName = ' ' ! Name of the fan
  CHARACTER(len=MaxNameLength) :: FanType = ' ' ! Type of Fan ie. Simple, Vane axial,
Centrifugal, etc.
  CHARACTER(len=MaxNameLength) :: Schedule = ' ' ! Fan Operation Schedule
  INTEGER      :: FanType_Num      =0 ! DataHVACGlobals fan type
  Integer      :: SchedPtr         =0 ! Pointer to the correct schedule
  REAL(r64)    :: InletAirMassFlowRate =0.0 !MassFlow through the Fan being Simulated
[kg/Sec]
  REAL(r64)    :: OutletAirMassFlowRate =0.0
  REAL(r64)    :: MaxAirFlowRate      =0.0 !Max Specified Volume Flow Rate of Fan [m3/sec]
  REAL(r64)    :: MinAirFlowRate      =0.0 !Min Specified Volume Flow Rate of Fan [m3/sec]
  REAL(r64)    :: MaxAirMassFlowRate  =0.0 ! Max flow rate of fan in kg/sec
  REAL(r64)    :: MinAirMassFlowRate  =0.0 ! Min flow rate of fan in kg/sec
  REAL(r64)    :: InletAirTemp        =0.0
  REAL(r64)    :: OutletAirTemp       =0.0
  REAL(r64)    :: InletAirHumRat      =0.0
  REAL(r64)    :: OutletAirHumRat     =0.0
  REAL(r64)    :: InletAirEnthalpy    =0.0
  REAL(r64)    :: OutletAirEnthalpy   =0.0
  REAL(r64)    :: FanPower            =0.0 !Power of the Fan being Simulated [kW]
  REAL(r64)    :: FanEnergy           =0.0 !Fan energy in [kJ]
  REAL(r64)    :: FanRuntimeFraction  =0.0 !Fraction of the timestep that the fan operates
  REAL(r64)    :: DeltaTemp          =0.0 !Temp Rise across the Fan [C]
  REAL(r64)    :: DeltaPress         =0.0 !Delta Pressure Across the Fan [N/m2]
  REAL(r64)    :: FanEff              =0.0 !Fan total efficiency; motor and mechanical
  REAL(r64)    :: MotEff              =0.0 !Fan motor efficiency
  REAL(r64)    :: MotInAirFrac       =0.0 !Fraction of motor heat entering air stream
  REAL(r64), Dimension(5):: FanCoeff =0.0 !Fan Part Load Coefficients to match fan
type
! Mass Flow Rate Control Variables
  REAL(r64)    :: MassFlowRateMaxAvail =0.0
  REAL(r64)    :: MassFlowRateMinAvail =0.0
  REAL(r64)    :: RhoAirStdInit       =0.0
  INTEGER      :: InletNodeNum        =0
  INTEGER      :: OutletNodeNum       =0
  INTEGER      :: NVPerfNum           =0
  INTEGER      :: FanPowerRatAtSpeedRatCurveIndex =0
  INTEGER      :: FanEffRatioCurveIndex =0
  CHARACTER(len=MaxNameLength) :: EndUseSubcategoryName=' '
  LOGICAL      :: OneTimePowerRatioCheck = .TRUE. ! one time flag used for error message
  LOGICAL      :: OneTimeEffRatioCheck = .TRUE. ! one time flag used for error message
END TYPE FanEquipConditions

TYPE NightVentPerfData
  CHARACTER(len=MaxNameLength) :: FanName = ' ' ! Name of the fan that will use this data
  REAL(r64)    :: FanEff              =0.0 !Fan total efficiency; motor and mechanical
  REAL(r64)    :: DeltaPress         =0.0 !Delta Pressure Across the Fan [N/m2]
  REAL(r64)    :: MaxAirFlowRate     =0.0 !Max Specified Volume Flow Rate of Fan [m3/s]
  REAL(r64)    :: MaxAirMassFlowRate =0.0 ! Max flow rate of fan in kg/sec
  REAL(r64)    :: MotEff              =0.0 !Fan motor efficiency
  REAL(r64)    :: MotInAirFrac       =0.0 !Fraction of motor heat entering air stream
END TYPE NightVentPerfData

!MODULE VARIABLE DECLARATIONS:
INTEGER :: NumFans =0 ! The Number of Fans found in the Input
INTEGER :: NumNightVentPerf =0 ! number of FAN:NIGHT VENT PERFORMANCE objects found in the input
TYPE (FanEquipConditions), ALLOCATABLE, DIMENSION(:) :: Fan
TYPE (NightVentPerfData), ALLOCATABLE, DIMENSION(:) :: NightVentPerf
LOGICAL :: GetFanInputFlag = .True. ! Flag set to make sure you get input once

! Subroutine Specifications for the Module
! Driver/Manager Routines
Public SimulateFanComponents

```

```

      ! Get Input routines for module
PRIVATE GetFanInput

      ! Initialization routines for module
PRIVATE InitFan
PRIVATE SizeFan

      ! Algorithms for the module
Private SimSimpleFan
PRIVATE SimVariableVolumeFan
PRIVATE SimZoneExhaustFan

      ! Update routine to check convergence and update nodes
Private UpdateFan

      ! Reporting routines for module
Private ReportFan

CONTAINS

! MODULE SUBROUTINES:
!*****
SUBROUTINE SimulateFanComponents (CompName, FirstHVACIteration)

      ! SUBROUTINE INFORMATION:
      !   AUTHOR      Richard Liesen
      !   DATE WRITTEN February 1998
      !   MODIFIED    na
      !   RE-ENGINEERED na

      ! PURPOSE OF THIS SUBROUTINE:
      ! This subroutine manages Fan component simulation.

      ! METHODOLOGY EMPLOYED:
      ! na

      ! REFERENCES:
      ! na

      ! USE STATEMENTS:
USE InputProcessor, ONLY: FindItemInList

IMPLICIT NONE      ! Enforce explicit typing of all variables in this routine

      ! SUBROUTINE ARGUMENT DEFINITIONS:
CHARACTER(len=*), INTENT(IN) :: CompName
LOGICAL,          INTENT (IN):: FirstHVACIteration

      ! SUBROUTINE PARAMETER DEFINITIONS:
      ! na

      ! INTERFACE BLOCK SPECIFICATIONS

      ! DERIVED TYPE DEFINITIONS
      ! na

      ! SUBROUTINE LOCAL VARIABLE DECLARATIONS:
INTEGER          :: FanNum      ! current fan number
LOGICAL,SAVE     :: GetInputFlag = .True.  ! Flag set to make sure you get input once

      ! FLOW:

! Obtains and Allocates fan related parameters from input file
IF (GetInputFlag) THEN !First time subroutine has been entered
  CALL GetFanInput
  GetInputFlag=.false.
End If

```

```

! Find the correct FanNumber with the AirLoop & CompNum from AirLoop Derived Type
!FanNum = AirLoopEquip(AirLoopNum)%ComponentOfTypeNum(CompNum)
! Determine which Fan given the Fan Name
FanNum = FindItemInList(CompName,Fan%FanName,NumFans)
IF (FanNum == 0) THEN
  CALL ShowFatalError('Fan not found= '//TRIM(CompName))
ENDIF

! With the correct FanNum Initialize
CALL InitFan(FanNum,FirstHVACIteration) ! Initialize all fan related parameters

! Calculate the Correct Fan Model with the current FanNum
IF (Fan(FanNum)%FanType_Num == FanType_SimpleConstVolume) THEN
  Call SimSimpleFan(FanNum)
Else IF (Fan(FanNum)%FanType_Num == FanType_SimpleVAV) THEN
  Call SimVariableVolumeFan(FanNum)
Else If (Fan(FanNum)%FanType_Num == FanType_SimpleOnOff) THEN
  Call SimOnOffFan(FanNum)
Else If (Fan(FanNum)%FanType_Num == FanType_ZoneExhaust) THEN
  Call SimZoneExhaustFan(FanNum)
End If
! Update the current fan to the outlet nodes
Call UpdateFan(FanNum)

! Report the current fan
Call ReportFan(FanNum)

RETURN

```

#### **END SUBROUTINE SimulateFanComponents**

```
! Get Input Section of the Module
```

```
!*****
```

#### **SUBROUTINE GetFanInput**

```
! SUBROUTINE INFORMATION:
```

```
!   AUTHOR      Richard Liesen
!   DATE WRITTEN April 1998
!   MODIFIED    Shirey, May 2001
!   RE-ENGINEERED na
```

```
! PURPOSE OF THIS SUBROUTINE:
```

```
! Obtains input data for fans and stores it in fan data structures
```

```
! METHODOLOGY EMPLOYED:
```

```
! Uses "Get" routines to read in data.
```

```
! REFERENCES:
```

```
! na
```

```
! USE STATEMENTS:
```

```
USE InputProcessor
USE NodeInputManager, ONLY: GetOnlySingleNode
USE CurveManager, ONLY: GetCurveIndex
USE BranchNodeConnections, ONLY: TestCompSet
! USE DataIPShortCuts
```

```
IMPLICIT NONE ! Enforce explicit typing of all variables in this routine
```

```
! SUBROUTINE ARGUMENT DEFINITIONS:
```

```
! na
```

```
! SUBROUTINE PARAMETER DEFINITIONS:
```

```
! na
```

```
! INTERFACE BLOCK SPECIFICATIONS
```

```
! na
```

```
! DERIVED TYPE DEFINITIONS
```

```
! na
```

```

      ! SUBROUTINE LOCAL VARIABLE DECLARATIONS:
INTEGER :: FanNum      ! The fan that you are currently loading input into
INTEGER :: NumSimpFan ! The number of Simple Const Vol Fans
INTEGER :: NumVarVolFan ! The number of Simple Variable Vol Fans
INTEGER :: NumOnOff   ! The number of Simple on-off Fans
INTEGER :: NumZoneExhFan
INTEGER :: SimpFanNum
INTEGER :: OnOffFanNum
INTEGER :: VarVolFanNum
INTEGER :: ExhFanNum
INTEGER :: NVPerfNum
LOGICAL :: NVPerfFanFound
INTEGER :: NumAlphas
INTEGER :: NumNums
INTEGER :: IOSTAT
LOGICAL :: ErrorsFound = .false. ! If errors detected in input
LOGICAL :: IsNotOK      ! Flag to verify name
LOGICAL :: IsBlank      ! Flag for blank name
CHARACTER(len=*) , PARAMETER :: RoutineName='GetFanInput: ' ! include trailing blank space
CHARACTER(len=MaxNameLength+40),ALLOCATABLE, DIMENSION(:) :: cAlphaFieldNames
CHARACTER(len=MaxNameLength+40),ALLOCATABLE, DIMENSION(:) :: cNumericFieldNames
LOGICAL, ALLOCATABLE, DIMENSION(:) :: lNumericFieldBlanks
LOGICAL, ALLOCATABLE, DIMENSION(:) :: lAlphaFieldBlanks
CHARACTER(len=MaxNameLength),ALLOCATABLE, DIMENSION(:) :: cAlphaArgs
REAL(r64),ALLOCATABLE, DIMENSION(:) :: rNumericArgs
CHARACTER(len=MaxNameLength) :: cCurrentModuleObject
INTEGER :: NumParams
INTEGER :: MaxAlphas
INTEGER :: MaxNumbers

      ! Flow
MaxAlphas=0
MaxNumbers=0
NumSimpFan = GetNumObjectsFound('Fan:ConstantVolume')
IF (NumSimpFan > 0) THEN
  CALL GetObjectDefMaxArgs('Fan:ConstantVolume',NumParams,NumAlphas,NumNums)
  MaxAlphas=MAX(MaxAlphas,NumAlphas)
  MaxNumbers=MAX(MaxNumbers,NumNums)
ENDIF
NumVarVolFan = GetNumObjectsFound('Fan:VariableVolume')
IF (NumVarVolFan > 0) THEN
  CALL GetObjectDefMaxArgs('Fan:VariableVolume',NumParams,NumAlphas,NumNums)
  MaxAlphas=MAX(MaxAlphas,NumAlphas)
  MaxNumbers=MAX(MaxNumbers,NumNums)
ENDIF
NumOnOff = GetNumObjectsFound('Fan:OnOff')
IF (NumOnOff > 0) THEN
  CALL GetObjectDefMaxArgs('Fan:OnOff',NumParams,NumAlphas,NumNums)
  MaxAlphas=MAX(MaxAlphas,NumAlphas)
  MaxNumbers=MAX(MaxNumbers,NumNums)
ENDIF
NumZoneExhFan = GetNumObjectsFound('Fan:ZoneExhaust')
IF (NumZoneExhFan > 0) THEN
  CALL GetObjectDefMaxArgs('Fan:ZoneExhaust',NumParams,NumAlphas,NumNums)
  MaxAlphas=MAX(MaxAlphas,NumAlphas)
  MaxNumbers=MAX(MaxNumbers,NumNums)
ENDIF
NumNightVentPerf = GetNumObjectsFound('FanPerformance:NightVentilation')
IF (NumNightVentPerf > 0) THEN
  CALL GetObjectDefMaxArgs('FanPerformance:NightVentilation',NumParams,NumAlphas,NumNums)
  MaxAlphas=MAX(MaxAlphas,NumAlphas)
  MaxNumbers=MAX(MaxNumbers,NumNums)
ENDIF
ALLOCATE(cAlphaArgs(MaxAlphas))
cAlphaArgs=' '
ALLOCATE(cAlphaFieldNames(MaxAlphas))
cAlphaFieldNames=' '
ALLOCATE(lAlphaFieldBlanks(MaxAlphas))
lAlphaFieldBlanks=.false.
ALLOCATE(cNumericFieldNames(MaxNumbers))

```

```

cNumericFieldNames=' '
ALLOCATE (lNumericFieldBlanks (MaxNumbers))
lNumericFieldBlanks=.false.
ALLOCATE (rNumericArgs (MaxNumbers))
rNumericArgs=0.0

NumFans = NumSimpFan + NumVarVolFan + NumZoneExhFan+NumOnOff
IF (NumFans > 0) THEN
  ALLOCATE (Fan (NumFans))
ENDIF

DO SimpFanNum = 1, NumSimpFan
  FanNum = SimpFanNum
  cCurrentModuleObject= 'Fan:ConstantVolume'
  CALL GetObjectItem (TRIM (cCurrentModuleObject), SimpFanNum, cAlphaArgs, NumAlphas, &
    rNumericArgs, NumNums, IOSTAT, &
    NumBlank=lNumericFieldBlanks, AlphaBlank=lAlphaFieldBlanks, &
    AlphaFieldNames=cAlphaFieldNames, NumericFieldNames=cNumericFieldNames)

  IsNotOK=.false.
  IsBlank=.false.
  CALL VerifyName (cAlphaArgs (1), Fan%FanName, FanNum-
1, IsNotOK, IsBlank, TRIM (cCurrentModuleObject) //' Name')
  IF (IsNotOK) THEN
    ErrorsFound=.true.
    IF (IsBlank) cAlphaArgs (1)='xxxxx'
  ENDIF
  Fan (FanNum)%FanName = cAlphaArgs (1)
  Fan (FanNum)%FanType = cCurrentModuleObject
  Fan (FanNum)%Schedule = cAlphaArgs (2)
  Fan (FanNum)%SchedPtr = GetScheduleIndex (cAlphaArgs (2))
  IF (Fan (FanNum)%SchedPtr == 0) THEN
    IF (lAlphaFieldBlanks (2)) THEN
      CALL ShowSevereError (RoutineName//TRIM (cCurrentModuleObject) //' :
'//TRIM (cAlphaFieldNames (2))// &
' is required, missing for
'//TRIM (cAlphaFieldNames (1))// '='//TRIM (cAlphaArgs (1)))
    ELSE
      CALL ShowSevereError (RoutineName//TRIM (cCurrentModuleObject) //' : invalid
'//TRIM (cAlphaFieldNames (2))// &
' entered ='//TRIM (cAlphaArgs (2))// &
' for '//TRIM (cAlphaFieldNames (1))// '='//TRIM (cAlphaArgs (1)))
    END IF
    ErrorsFound=.true.
  END IF
  ! Fan (FanNum)%Control = 'CONSTVOLUME'
  Fan (FanNum)%FanType_Num=FanType_SimpleConstVolume

  Fan (FanNum)%FanEff = rNumericArgs (1)
  Fan (FanNum)%DeltaPress = rNumericArgs (2)
  Fan (FanNum)%MaxAirFlowRate= rNumericArgs (3)
  IF (Fan (FanNum)%MaxAirFlowRate == 0.0) THEN
    CALL ShowWarningError (TRIM (cCurrentModuleObject) //'="'//TRIM (Fan (FanNum)%FanName)// &
' " has specified 0.0 max air flow rate. It will not be used in the simulation.')
  ENDIF
  Fan (FanNum)%MotEff = rNumericArgs (4)
  Fan (FanNum)%MotInAirFrac = rNumericArgs (5)
  Fan (FanNum)%MinAirFlowRate= 0.0

  Fan (FanNum)%InletNodeNum = &

  GetOnlySingleNode (cAlphaArgs (3), ErrorsFound, TRIM (cCurrentModuleObject), cAlphaArgs (1), &
    NodeType_Air, NodeConnectionType_Inlet, 1, ObjectIsNotParent)
  Fan (FanNum)%OutletNodeNum = &

  GetOnlySingleNode (cAlphaArgs (4), ErrorsFound, TRIM (cCurrentModuleObject), cAlphaArgs (1), &
    NodeType_Air, NodeConnectionType_Outlet, 1, ObjectIsNotParent)

  IF (NumAlphas > 4) THEN
    Fan (FanNum)%EndUseSubcategoryName = cAlphaArgs (5)
  ELSE
    Fan (FanNum)%EndUseSubcategoryName = 'General'
  ENDIF

```

```

END IF

CALL TestCompSet (TRIM(cCurrentModuleObject), cAlphaArgs (1), cAlphaArgs (3), cAlphaArgs (4), 'Air
Nodes')

END DO ! end Number of Simple FAN Loop

DO VarVolFanNum = 1, NumVarVolFan
  FanNum = NumSimpFan + VarVolFanNum
  cCurrentModuleObject= 'Fan:VariableVolume'
  CALL GetObjectItem (TRIM(cCurrentModuleObject), VarVolFanNum, cAlphaArgs, NumAlphas, &
    rNumericArgs, NumNums, IOSTAT, &
    NumBlank=lNumericFieldBlanks, AlphaBlank=lAlphaFieldBlanks, &
    AlphaFieldNames=cAlphaFieldNames, NumericFieldNames=cNumericFieldNames)

  IsNotOK=.false.
  IsBlank=.false.
  CALL VerifyName (cAlphaArgs (1), Fan%FanName, FanNum-
1, IsNotOK, IsBlank, TRIM(cCurrentModuleObject) //' Name')
  IF (IsNotOK) THEN
    ErrorsFound=.true.
    IF (IsBlank) cAlphaArgs (1)='xxxxx'
  ENDIF
  Fan (FanNum) %FanName = cAlphaArgs (1)
  Fan (FanNum) %FanType = cCurrentModuleObject
  Fan (FanNum) %Schedule = cAlphaArgs (2)
  Fan (FanNum) %SchedPtr =GetScheduleIndex (cAlphaArgs (2))
  IF (Fan (FanNum) %SchedPtr == 0) THEN
    IF (lAlphaFieldBlanks (2)) THEN
      CALL ShowSevereError (RoutineName//TRIM(cCurrentModuleObject) //' :
'//TRIM(cAlphaFieldNames (2)) // &
' is required, missing for
'//TRIM(cAlphaFieldNames (1)) //'='//TRIM(cAlphaArgs (1))
    ELSE
      CALL ShowSevereError (RoutineName//TRIM(cCurrentModuleObject) //' : invalid
'//TRIM(cAlphaFieldNames (2)) // &
' entered ='//TRIM(cAlphaArgs (2)) // &
' for '//TRIM(cAlphaFieldNames (1)) //'='//TRIM(cAlphaArgs (1))
    END IF
    ErrorsFound=.true.
  ENDIF
! Fan (FanNum) %Control = 'VARIABLEVOLUME'
Fan (FanNum) %FanType_Num=FanType_SimpleVAV

Fan (FanNum) %FanEff = rNumericArgs (1)
Fan (FanNum) %DeltaPress = rNumericArgs (2)
Fan (FanNum) %MaxAirFlowRate= rNumericArgs (3)
IF (Fan (FanNum) %MaxAirFlowRate == 0.0) THEN
  CALL ShowWarningError (TRIM(cCurrentModuleObject) //'='//TRIM(Fan (FanNum) %FanName) // &
' has specified 0.0 max air flow rate. It will not be used in the simulation.')
ENDIF
Fan (FanNum) %MinAirFlowRate= rNumericArgs (4)
Fan (FanNum) %MotEff = rNumericArgs (5)
Fan (FanNum) %MotInAirFrac = rNumericArgs (6)
Fan (FanNum) %FanCoeff (1) = rNumericArgs (7)
Fan (FanNum) %FanCoeff (2) = rNumericArgs (8)
Fan (FanNum) %FanCoeff (3) = rNumericArgs (9)
Fan (FanNum) %FanCoeff (4) = rNumericArgs (10)
Fan (FanNum) %FanCoeff (5) = rNumericArgs (11)
IF (Fan (FanNum) %FanCoeff (1) == 0.0 .and. Fan (FanNum) %FanCoeff (2) == 0.0 .and. &
Fan (FanNum) %FanCoeff (3) == 0.0 .and. Fan (FanNum) %FanCoeff (4) == 0.0 .and. &
Fan (FanNum) %FanCoeff (5) == 0.0) THEN
  CALL ShowWarningError ('Fan Coefficients are all zero. No Fan power will be
reported.')
  CALL ShowContinueError ('For '//TRIM(cCurrentModuleObject) //' ,
Fan='//TRIM(cAlphaArgs (1))
  ENDIF
  Fan (FanNum) %InletNodeNum = &
GetOnlySingleNode (cAlphaArgs (3), ErrorsFound, TRIM(cCurrentModuleObject), cAlphaArgs (1), &

```

```

                NodeType_Air,NodeConnectionType_Inlet,1,ObjectIsNotParent)
    Fan(FanNum)%OutletNodeNum = &
GetOnlySingleNode(cAlphaArgs(4),ErrorsFound,TRIM(cCurrentModuleObject),cAlphaArgs(1), &
                NodeType_Air,NodeConnectionType_Outlet,1,ObjectIsNotParent)

    IF (NumAlphas > 4) THEN
        Fan(FanNum)%EndUseSubcategoryName = cAlphaArgs(5)
    ELSE
        Fan(FanNum)%EndUseSubcategoryName = 'General'
    END IF

    CALL TestCompSet(TRIM(cCurrentModuleObject),cAlphaArgs(1),cAlphaArgs(3),cAlphaArgs(4),'Air
Nodes')

END DO    ! end Number of Variable Volume FAN Loop

DO ExhFanNum = 1, NumZoneExhFan
    FanNum = NumSimpFan + NumVarVolFan + ExhFanNum
    cCurrentModuleObject= 'Fan:ZoneExhaust'
    CALL GetObjectItem(TRIM(cCurrentModuleObject),ExhFanNum,cAlphaArgs,NumAlphas, &
        rNumericArgs,NumNums,IOSTAT, &
        NumBlank=lNumericFieldBlanks,AlphaBlank=lAlphaFieldBlanks, &
        AlphaFieldNames=cAlphaFieldNames,NumericFieldNames=cNumericFieldNames)

    IsNotOK=.false.
    IsBlank=.false.
    CALL VerifyName(cAlphaArgs(1),Fan%FanName,FanNum-
1,IsNotOK,IsBlank,TRIM(cCurrentModuleObject)//' Name')
    IF (IsNotOK) THEN
        ErrorsFound=.true.
        IF (IsBlank) cAlphaArgs(1)='xxxxx'
    ENDIF
    Fan(FanNum)%FanName = cAlphaArgs(1)
    Fan(FanNum)%FanType = cCurrentModuleObject
    Fan(FanNum)%Schedule = cAlphaArgs(2)
    Fan(FanNum)%SchedPtr =GetScheduleIndex(cAlphaArgs(2))
    IF (Fan(FanNum)%SchedPtr == 0) THEN
        IF (lAlphaFieldBlanks(2)) THEN
            CALL ShowSevereError(RoutineName//TRIM(cCurrentModuleObject)//':
//TRIM(cAlphaFieldNames(2))// &
                ' is required, missing for
//TRIM(cAlphaFieldNames(1))//='//TRIM(cAlphaArgs(1))
            ELSE
                CALL ShowSevereError(RoutineName//TRIM(cCurrentModuleObject)//': invalid
//TRIM(cAlphaFieldNames(2))// &
                ' entered ='//TRIM(cAlphaArgs(2))// &
                ' for '//TRIM(cAlphaFieldNames(1))//='//TRIM(cAlphaArgs(1))
            END IF
            ErrorsFound=.true.
        ELSE
            IF (HasFractionalScheduleValue(Fan(FanNum)%SchedPtr)) THEN
                CALL ShowWarningError(TRIM(cCurrentModuleObject)//'='//TRIM(Fan(FanNum)%FanName)// &
                    '" has fractional values in Schedule='//TRIM(cAlphaArgs(2))//'. Only 0.0 in the
schedule value turns the fan off.')
            ENDIF
        ENDIF
    !
        Fan(FanNum)%Control = 'CONSTVOLUME'
        Fan(FanNum)%FanType_Num=FanType_ZoneExhaust

        Fan(FanNum)%FanEff          = rNumericArgs(1)
        Fan(FanNum)%DeltaPress      = rNumericArgs(2)
        Fan(FanNum)%MaxAirFlowRate= rNumericArgs(3)
        Fan(FanNum)%MotEff          = 1.0
        Fan(FanNum)%MotInAirFrac    = 1.0
        Fan(FanNum)%MinAirFlowRate= 0.0
        Fan(FanNum)%RhoAirStdInit   = StdRhoAir
        Fan(FanNum)%MaxAirMassFlowRate = Fan(FanNum)%MaxAirFlowRate * Fan(FanNum)%RhoAirStdInit

        IF (Fan(FanNum)%MaxAirFlowRate == 0.0) THEN
            CALL ShowWarningError(TRIM(cCurrentModuleObject)//'='//TRIM(Fan(FanNum)%FanName)// &
                '" has specified 0.0 max air flow rate. It will not be used in the simulation.')

```

```

ENDIF

Fan(FanNum)%InletNodeNum = &
GetOnlySingleNode(cAlphaArgs(3),ErrorsFound,TRIM(cCurrentModuleObject),cAlphaArgs(1), &
NodeTypes_Air,NodeConnectionType_Inlet,1,ObjectIsNotParent)
Fan(FanNum)%OutletNodeNum = &
GetOnlySingleNode(cAlphaArgs(4),ErrorsFound,TRIM(cCurrentModuleObject),cAlphaArgs(1), &
NodeTypes_Air,NodeConnectionType_Outlet,1,ObjectIsNotParent)

IF (NumAlphas > 4) THEN
Fan(FanNum)%EndUseSubcategoryName = cAlphaArgs(5)
ELSE
Fan(FanNum)%EndUseSubcategoryName = 'General'
END IF

! Component sets not setup yet for zone equipment
! CALL
TestCompSet(TRIM(cCurrentModuleObject),cAlphaArgs(1),cAlphaArgs(3),cAlphaArgs(4),'Air Nodes')

END DO ! end of Zone Exhaust Fan loop

DO OnOffFanNum = 1, NumOnOff
FanNum = NumSimpFan + NumVarVolFan + NumZoneExhFan + OnOffFanNum
cCurrentModuleObject= 'Fan:OnOff'
CALL GetObjectItem(TRIM(cCurrentModuleObject),OnOffFanNum,cAlphaArgs,NumAlphas, &
rNumericArgs,NumNums,IOSTAT, &
NumBlank=1NumericFieldBlanks,AlphaBlank=1AlphaFieldBlanks, &
AlphaFieldNames=cAlphaFieldNames,NumericFieldNames=cNumericFieldNames)

IsNotOK=.false.
IsBlank=.false.
CALL VerifyName(cAlphaArgs(1),Fan%FanName,FanNum-
1,IsNotOK,IsBlank,TRIM(cCurrentModuleObject)//' Name')
IF (IsNotOK) THEN
ErrorsFound=.true.
IF (IsBlank) cAlphaArgs(1)='xxxxx'
ENDIF
Fan(FanNum)%FanName = cAlphaArgs(1)
Fan(FanNum)%FanType = cCurrentModuleObject
Fan(FanNum)%Schedule = cAlphaArgs(2)
Fan(FanNum)%SchedPtr = GetScheduleIndex(cAlphaArgs(2))
IF (Fan(FanNum)%SchedPtr == 0) THEN
IF (1AlphaFieldBlanks(2)) THEN
CALL ShowSevereError(RoutineName//TRIM(cCurrentModuleObject)//':
//TRIM(cAlphaFieldNames(2))// &
' is required, missing for
//TRIM(cAlphaFieldNames(1))//'='//TRIM(cAlphaArgs(1)))
ELSE
CALL ShowSevereError(RoutineName//TRIM(cCurrentModuleObject)//': invalid
//TRIM(cAlphaFieldNames(2))// &
' entered ='//TRIM(cAlphaArgs(2))// &
' for '//TRIM(cAlphaFieldNames(1))//'='//TRIM(cAlphaArgs(1)))
END IF
ErrorsFound=.true.
ENDIF
! Fan(FanNum)%Control = 'ONOFF'
Fan(FanNum)%FanType_Num=FanType_SimpleOnOff

Fan(FanNum)%FanEff = rNumericArgs(1)
Fan(FanNum)%DeltaPress = rNumericArgs(2)
Fan(FanNum)%MaxAirFlowRate= rNumericArgs(3)
IF (Fan(FanNum)%MaxAirFlowRate == 0.0) THEN
CALL ShowWarningError(TRIM(cCurrentModuleObject)//'='//TRIM(Fan(FanNum)%FanName)// &
'" has specified 0.0 max air flow rate. It will not be used in the simulation.')
ENDIF

! the following two structure variables are set here, as well as in InitFan, for the Heat
Pump:Water Heater object
! (Standard Rating procedure may be called before BeginEnvirFlag is set to TRUE, if so
MaxAirMassFlowRate = 0)

```



```

Fan(FanNum)%RhoAirStdInit = StdRhoAir
Fan(FanNum)%MaxAirMassFlowRate = Fan(FanNum)%MaxAirFlowRate * Fan(FanNum)%RhoAirStdInit

Fan(FanNum)%MotEff          = rNumericArgs(4)
Fan(FanNum)%MotInAirFrac   = rNumericArgs(5)
Fan(FanNum)%MinAirFlowRate= 0.0

Fan(FanNum)%InletNodeNum   = &

GetOnlySingleNode(cAlphaArgs(3),ErrorsFound,TRIM(cCurrentModuleObject),cAlphaArgs(1), &
                 NodeType_Air,NodeConnectionType_Inlet,1,ObjectIsNotParent)
Fan(FanNum)%OutletNodeNum = &

GetOnlySingleNode(cAlphaArgs(4),ErrorsFound,TRIM(cCurrentModuleObject),cAlphaArgs(1), &
                 NodeType_Air,NodeConnectionType_Outlet,1,ObjectIsNotParent)

IF (NumAlphas > 4 .AND. .NOT. lAlphaFieldBlanks(5)) THEN
  Fan(FanNum)%FanPowerRatAtSpeedRatCurveIndex = GetCurveIndex(cAlphaArgs(5))
END IF

IF (NumAlphas > 5 .AND. .NOT. lAlphaFieldBlanks(6)) THEN
  Fan(FanNum)%FanEffRatioCurveIndex = GetCurveIndex(cAlphaArgs(6))
END IF

IF (NumAlphas > 6 .AND. .NOT. lAlphaFieldBlanks(7)) THEN
  Fan(FanNum)%EndUseSubcategoryName = cAlphaArgs(7)
ELSE
  Fan(FanNum)%EndUseSubcategoryName = 'General'
END IF

CALL TestCompSet (TRIM(cCurrentModuleObject),cAlphaArgs(1),cAlphaArgs(3),cAlphaArgs(4),'Air
Nodes')

END DO ! end Number of Simple ON-OFF FAN Loop

cCurrentModuleObject= 'FanPerformance:NightVentilation'
NumNightVentPerf = GetNumObjectsFound(TRIM(cCurrentModuleObject))

IF (NumNightVentPerf > 0) THEN
  ALLOCATE (NightVentPerf(NumNightVentPerf))
  NightVentPerf%FanName = ' '
  NightVentPerf%FanEff = 0.0
  NightVentPerf%DeltaPress = 0.0
  NightVentPerf%MaxAirFlowRate = 0.0
  NightVentPerf%MotEff = 0.0
  NightVentPerf%MotInAirFrac = 0.0
  NightVentPerf%MaxAirMassFlowRate = 0.0
END IF
! input the night ventilation performance objects
DO NVPerfNum=1,NumNightVentPerf
  CALL GetObjectItem(TRIM(cCurrentModuleObject),NVPerfNum,cAlphaArgs,NumAlphas, &
                   rNumericArgs,NumNums,IOSTAT, &
                   NumBlank=lNumericFieldBlanks,AlphaBlank=lAlphaFieldBlanks, &
                   AlphaFieldNames=cAlphaFieldNames,NumericFieldNames=cNumericFieldNames)

  IsNotOK=.false.
  IsBlank=.false.
  CALL VerifyName(cAlphaArgs(1),NightVentPerf%FanName,NVPerfNum-
1,IsNotOK,IsBlank,TRIM(cCurrentModuleObject)//' Name')
  IF (IsNotOK) THEN
    ErrorsFound=.true.
    IF (IsBlank) cAlphaArgs(1)='xxxxx'
  ENDIF
  NightVentPerf(NVPerfNum)%FanName          = cAlphaArgs(1)
  NightVentPerf(NVPerfNum)%FanEff          = rNumericArgs(1)
  NightVentPerf(NVPerfNum)%DeltaPress      = rNumericArgs(2)
  NightVentPerf(NVPerfNum)%MaxAirFlowRate = rNumericArgs(3)
  NightVentPerf(NVPerfNum)%MotEff         = rNumericArgs(4)
  NightVentPerf(NVPerfNum)%MotInAirFrac   = rNumericArgs(5)
  ! find the corresponding fan

```

```

NVPerfFanFound = .FALSE.
DO FanNum=1,NumFans
  IF (NightVentPerf(NVPerfNum)%FanName == Fan(FanNum)%FanName) THEN
    NVPerfFanFound = .TRUE.
    Fan(FanNum)%NVPerfNum = NVPerfNum
    EXIT
  END IF
END DO
IF (.NOT. NVPerfFanFound) THEN
  CALL ShowSevereError(TRIM(cCurrentModuleObject)//', fan name not
found='//TRIM(cAlphaArgs(1)))
  ErrorsFound=.true.
END IF

END DO

DEALLOCATE(cAlphaArgs)
DEALLOCATE(cAlphaFieldNames)
DEALLOCATE(lAlphaFieldBlanks)
DEALLOCATE(cNumericFieldNames)
DEALLOCATE(lNumericFieldBlanks)
DEALLOCATE(rNumericArgs)

IF (ErrorsFound) THEN
  CALL ShowFatalError(RoutineName//'Errors found in input. Program terminates.')
ENDIF

Do FanNum=1,NumFans
  ! Setup Report variables for the Fans
  CALL SetupOutputVariable('Fan Electric Power[W]', Fan(FanNum)%FanPower,
'System','Average',Fan(FanNum)%FanName)
  CALL SetupOutputVariable('Fan Delta Temp[C]', Fan(FanNum)%DeltaTemp,
'System','Average',Fan(FanNum)%FanName)
  CALL SetupOutputVariable('Fan Electric Consumption[J]', Fan(FanNum)%FanEnergy,
'System','Sum',Fan(FanNum)%FanName, &
                          ResourceTypeKey='Electric',GroupKey='System', &
                          EndUseKey='Fans',EndUseSubKey=Fan(FanNum)%EndUseSubcategoryName)
END DO

DO OnOffFanNum = 1, NumOnOff
  FanNum = NumSimpFan + NumVarVolFan + NumZoneExhFan + OnOffFanNum
  CALL SetupOutputVariable('On/Off Fan Runtime Fraction', Fan(FanNum)%FanRuntimeFraction,
'System','Average', &
                          Fan(FanNum)%FanName)
END DO
RETURN

```

**END SUBROUTINE GetFanInput**

```

! End of Get Input subroutines for the HB Module
!*****

! Beginning Initialization Section of the Module
!*****

```

**SUBROUTINE InitFan(FanNum,FirstHVACIteration)**

```

  ! SUBROUTINE INFORMATION:
  !   AUTHOR           Richard J. Liesen
  !   DATE WRITTEN    February 1998
  !   MODIFIED        na
  !   RE-ENGINEERED   na

  ! PURPOSE OF THIS SUBROUTINE:
  ! This subroutine is for initializations of the Fan Components.

  ! METHODOLOGY EMPLOYED:
  ! Uses the status flags to trigger initializations.

```

```

! REFERENCES:
! na

! USE STATEMENTS:
USE DataSizing, ONLY: CurSysNum
USE DataAirLoop, ONLY: AirLoopControlInfo

IMPLICIT NONE      ! Enforce explicit typing of all variables in this routine

! SUBROUTINE ARGUMENT DEFINITIONS:
LOGICAL, INTENT (IN):: FirstHVACIteration
Integer, Intent(IN) :: FanNum

! SUBROUTINE PARAMETER DEFINITIONS:
! na

! INTERFACE BLOCK SPECIFICATIONS
! na

! DERIVED TYPE DEFINITIONS
! na

! SUBROUTINE LOCAL VARIABLE DECLARATIONS:
Integer      :: InletNode
Integer      :: OutletNode
Integer      :: InNode
Integer      :: OutNode
LOGICAL,SAVE :: MyOneTimeFlag = .true.
LOGICAL, ALLOCATABLE,Save, DIMENSION(:) :: MyEnvrnFlag
LOGICAL, ALLOCATABLE,Save, DIMENSION(:) :: MySizeFlag

! FLOW:

IF (MyOneTimeFlag) THEN

  ALLOCATE(MyEnvrnFlag(NumFans))
  ALLOCATE(MySizeFlag(NumFans))
  MyEnvrnFlag = .TRUE.
  MySizeFlag = .TRUE.

  MyOneTimeFlag = .false.

END IF

IF ( .NOT. SysSizingCalc .AND. MySizeFlag(FanNum)) THEN

  CALL SizeFan(FanNum)
  ! Set the loop cycling flag
  IF (Fan(FanNum)%Control == 'ONOFF') THEN
    IF (CurSysNum > 0) THEN
      AirLoopControlInfo(CurSysNum)%CyclingFan = .TRUE.
    END IF
  END IF

  MySizeFlag(FanNum) = .FALSE.
END IF

! Do the Begin Environment initializations
IF (BeginEnvrnFlag .and. MyEnvrnFlag(FanNum)) THEN

  !For all Fan inlet nodes convert the Volume flow to a mass flow
  InNode = Fan(FanNum)%InletNodeNum
  OutNode = Fan(FanNum)%OutletNodeNum
  Fan(FanNum)%RhoAirStdInit = PsyRhoAirFnPbTdbW(StdBaroPress,20.0,0.0)

  !Change the Volume Flow Rates to Mass Flow Rates

  Fan(FanNum)%MaxAirMassFlowRate = Fan(FanNum)%MaxAirFlowRate * Fan(FanNum)%RhoAirStdInit
  Fan(FanNum)%MinAirMassFlowRate = Fan(FanNum)%MinAirFlowRate * Fan(FanNum)%RhoAirStdInit

```

```

!Init the Node Control variables
Node(OutNode)%MassFlowRateMax = Fan(FanNum)%MaxAirMassFlowRate
Node(OutNode)%MassFlowRateMin = Fan(FanNum)%MinAirMassFlowRate

!Initialize all report variables to a known state at beginning of simulation
Fan(FanNum)%FanPower = 0.0
Fan(FanNum)%DeltaTemp = 0.0
Fan(FanNum)%FanEnergy = 0.0

MyEnvrnFlag(FanNum) = .FALSE.
END IF

IF (.not. BeginEnvrnFlag) THEN
  MyEnvrnFlag(FanNum) = .true.
ENDIF

! Do the Begin Day initializations
! none

! Do the begin HVAC time step initializations
! none

! Do the following initializations (every time step): This should be the info from
! the previous components outlets or the node data in this section.

! Do a check and make sure that the max and min available(control) flow is
! between the physical max and min for the Fan while operating.

InletNode = Fan(FanNum)%InletNodeNum
OutletNode = Fan(FanNum)%OutletNodeNum

Fan(FanNum)%MassFlowRateMaxAvail = MIN(Node(OutletNode)%MassFlowRateMax, &
                                         Node(InletNode)%MassFlowRateMaxAvail)
Fan(FanNum)%MassFlowRateMinAvail = MIN(MAX(Node(OutletNode)%MassFlowRateMin, &
                                         Node(InletNode)%MassFlowRateMinAvail), &
                                         Node(InletNode)%MassFlowRateMaxAvail)

! Load the node data in this section for the component simulation
!
!First need to make sure that the massflowrate is between the max and min avail.
IF (Fan(FanNum)%FanType .NE. 'ZONE EXHAUST FAN') THEN
  Fan(FanNum)%InletAirMassFlowRate = Min(Node(InletNode)%MassFlowRate, &
                                         Fan(FanNum)%MassFlowRateMaxAvail)
  Fan(FanNum)%InletAirMassFlowRate = Max(Fan(FanNum)%InletAirMassFlowRate, &
                                         Fan(FanNum)%MassFlowRateMinAvail)
ELSE ! zone exhaust fans - always run at the max
  Fan(FanNum)%MassFlowRateMaxAvail = Fan(FanNum)%MaxAirMassFlowRate
  Fan(FanNum)%MassFlowRateMinAvail = 0.0
  Fan(FanNum)%InletAirMassFlowRate = Fan(FanNum)%MassFlowRateMaxAvail
END IF

!Then set the other conditions
Fan(FanNum)%InletAirTemp = Node(InletNode)%Temp
Fan(FanNum)%InletAirHumRat = Node(InletNode)%HumRat
Fan(FanNum)%InletAirEnthalpy = Node(InletNode)%Enthalpy

RETURN

END SUBROUTINE InitFan

SUBROUTINE SizeFan (FanNum)

      ! SUBROUTINE INFORMATION:
      !   AUTHOR      Fred Buhl
      !   DATE WRITTEN September 2001
      !   MODIFIED    na
      !   RE-ENGINEERED na

      ! PURPOSE OF THIS SUBROUTINE:

```

```

! This subroutine is for sizing Fan Components for which flow rates have not been
! specified in the input.

! METHODOLOGY EMPLOYED:
! Obtains flow rates from the zone or system sizing arrays.

! REFERENCES:
! na

! USE STATEMENTS:
USE DataSizing

IMPLICIT NONE      ! Enforce explicit typing of all variables in this routine

! SUBROUTINE ARGUMENT DEFINITIONS:
Integer, Intent(IN) :: FanNum

! SUBROUTINE PARAMETER DEFINITIONS:
! na

! INTERFACE BLOCK SPECIFICATIONS
! na

! DERIVED TYPE DEFINITIONS
! na

! SUBROUTINE LOCAL VARIABLE DECLARATIONS:
REAL :: FanMinAirFlowRate
EXTERNAL ReportSizingOutput

FanMinAirFlowRate = 0.0
IF (Fan(FanNum)%MaxAirFlowRate == AutoSize) THEN

  IF (CurSysNum > 0) THEN

    CALL CheckSysSizing('FAN:'//TRIM(Fan(FanNum)%FanType)// ':' // TRIM(Fan(FanNum)%Control), &
      Fan(FanNum)%FanName)

    SELECT CASE (CurDuctType)
    CASE (Main)
      Fan(FanNum)%MaxAirFlowRate = FinalSysSizing(CurSysNum)%DesMainVolFlow
      FanMinAirFlowRate = CalcSysSizing(CurSysNum)%SysAirMinFlowRat *
CalcSysSizing(CurSysNum)%DesMainVolFlow
    CASE (Cooling)
      Fan(FanNum)%MaxAirFlowRate = FinalSysSizing(CurSysNum)%DesCoolVolFlow
      FanMinAirFlowRate = CalcSysSizing(CurSysNum)%SysAirMinFlowRat *
CalcSysSizing(CurSysNum)%DesCoolVolFlow
    CASE (Heating)
      Fan(FanNum)%MaxAirFlowRate = FinalSysSizing(CurSysNum)%DesHeatVolFlow
      FanMinAirFlowRate = CalcSysSizing(CurSysNum)%SysAirMinFlowRat *
CalcSysSizing(CurSysNum)%DesHeatVolFlow
    CASE (Other)
      Fan(FanNum)%MaxAirFlowRate = FinalSysSizing(CurSysNum)%DesMainVolFlow
      FanMinAirFlowRate = CalcSysSizing(CurSysNum)%SysAirMinFlowRat *
CalcSysSizing(CurSysNum)%DesMainVolFlow
    CASE DEFAULT
      Fan(FanNum)%MaxAirFlowRate = FinalSysSizing(CurSysNum)%DesMainVolFlow
      FanMinAirFlowRate = CalcSysSizing(CurSysNum)%SysAirMinFlowRat *
CalcSysSizing(CurSysNum)%DesMainVolFlow
    END SELECT

  ELSE IF (CurZoneEqNum > 0) THEN

    CALL CheckZoneSizing('FAN:' // TRIM(Fan(FanNum)%FanType) // ':' //
TRIM(Fan(FanNum)%Control), &
      Fan(FanNum)%FanName)
    IF (.NOT. ZoneHeatingOnlyFan) THEN
      Fan(FanNum)%MaxAirFlowRate = MAX(FinalZoneSizing(CurZoneEqNum)%DesCoolVolFlow, &
        FinalZoneSizing(CurZoneEqNum)%DesHeatVolFlow)
    ELSE
      Fan(FanNum)%MaxAirFlowRate = FinalZoneSizing(CurZoneEqNum)%DesHeatVolFlow
    END IF
  END IF
END IF

```

```

        END IF

    END IF

    IF (Fan(FanNum)%MaxAirFlowRate < SmallAirVolFlow) THEN
        Fan(FanNum)%MaxAirFlowRate = 0.0
    END IF

    CALL ReportSizingOutput('FAN:' // TRIM(Fan(FanNum)%FanType) // ':' //
TRIM(Fan(FanNum)%Control), &
        Fan(FanNum)%FanName, 'Max Flow Rate [m3/s]',
Fan(FanNum)%MaxAirFlowRate)

    IF (Fan(FanNum)%Control == 'VARIABLEVOLUME') THEN
        CALL CheckSysSizing('FAN:' // TRIM(Fan(FanNum)%FanType) // ':' // TRIM(Fan(FanNum)%Control),
&
            Fan(FanNum)%FanName)
        Fan(FanNum)%MinAirFlowRate = FanMinAirFlowRate
        CALL ReportSizingOutput('FAN:' // TRIM(Fan(FanNum)%FanType) // ':' //
TRIM(Fan(FanNum)%Control), &
            Fan(FanNum)%FanName, 'Min Flow Rate [m3/s]',
Fan(FanNum)%MinAirFlowRate)
    END IF

    END IF

    RETURN

END SUBROUTINE SizeFan

! End Initialization Section of the Module
!*****

! Begin Algorithm Section of the Module
!*****

SUBROUTINE SimSimpleFan (FanNum)

    ! SUBROUTINE INFORMATION:
    !     AUTHOR      Unknown
    !     DATE WRITTEN Unknown
    !     MODIFIED    na
    !     RE-ENGINEERED na

    ! PURPOSE OF THIS SUBROUTINE:
    ! This subroutine simulates the simple constant volume fan.

    ! METHODOLOGY EMPLOYED:
    ! Converts design pressure rise and efficiency into fan power and temperature rise
    ! Constant fan pressure rise is assumed.

    ! REFERENCES:
    ! ASHRAE HVAC 2 Toolkit, page 2-3 (FANSIM)

    ! USE STATEMENTS:
    ! na

    IMPLICIT NONE      ! Enforce explicit typing of all variables in this routine

    ! SUBROUTINE ARGUMENT DEFINITIONS:
    Integer, Intent(IN) :: FanNum

    ! SUBROUTINE PARAMETER DEFINITIONS:
    ! na

    ! INTERFACE BLOCK SPECIFICATIONS
    ! na

    ! DERIVED TYPE DEFINITIONS
    ! na

```

```

      ! SUBROUTINE LOCAL VARIABLE DECLARATIONS:
      Real RhoAir
      Real DeltaPress ! [N/M^2]
      Real FanEff
      Real MassFlow ! [kg/sec]
      Real Tin ! [C]
      Real Win
      Real FanShaftPower ! power delivered to fan shaft
      Real PowerLossToAir ! fan and motor loss to air stream (watts)

      DeltaPress = Fan(FanNum)%DeltaPress
      FanEff = Fan(FanNum)%FanEff

      ! For a Constant Volume Simple Fan the Max Flow Rate is the Flow Rate for the fan
      Tin = Fan(FanNum)%InletAirTemp
      Win = Fan(FanNum)%InletAirHumRat
      RhoAir = Fan(FanNum)%RhoAirStdInit
      MassFlow = MIN(Fan(FanNum)%InletAirMassFlowRate, Fan(FanNum)%MaxAirMassFlowRate)
      MassFlow = MAX(MassFlow, Fan(FanNum)%MinAirMassFlowRate)
      !
      ! Determine the Fan Schedule for the Time step
      If( ( GetCurrentScheduleValue(Fan(FanNum)%SchedPtr)>0.0 .and. Massflow>0.0 .or. TurnFansOn .and.
      Massflow>0.0) &
      .and. .NOT.TurnFansOff ) Then
      ! Fan is operating
      Fan(FanNum)%FanPower = MassFlow*DeltaPress/(FanEff*RhoAir) ! total fan power
      FanShaftPower = Fan(FanNum)%MotEff * Fan(FanNum)%FanPower ! power delivered to shaft
      PowerLossToAir = FanShaftPower + (Fan(FanNum)%FanPower - FanShaftPower) *
      Fan(FanNum)%MotInAirFrac
      Fan(FanNum)%OutletAirEnthalpy = Fan(FanNum)%InletAirEnthalpy + PowerLossToAir/MassFlow
      ! This fan does not change the moisture or Mass Flow across the component
      Fan(FanNum)%OutletAirHumRat = Fan(FanNum)%InletAirHumRat
      Fan(FanNum)%OutletAirMassFlowRate = MassFlow
      Fan(FanNum)%OutletAirTemp =
      PsyTdbFnHW(Fan(FanNum)%OutletAirEnthalpy, Fan(FanNum)%OutletAirHumRat)
    Else
      ! Fan is off and not operating no power consumed and mass flow rate.
      Fan(FanNum)%FanPower = 0.0
      FanShaftPower = 0.0
      PowerLossToAir = 0.0
      Fan(FanNum)%OutletAirMassFlowRate = 0.0
      Fan(FanNum)%OutletAirHumRat = Fan(FanNum)%InletAirHumRat
      Fan(FanNum)%OutletAirEnthalpy = Fan(FanNum)%InletAirEnthalpy
      Fan(FanNum)%OutletAirTemp = Fan(FanNum)%InletAirTemp
      ! Set the Control Flow variables to 0.0 flow when OFF.
      Fan(FanNum)%MassFlowRateMaxAvail = 0.0
      Fan(FanNum)%MassFlowRateMinAvail = 0.0

    End If

    RETURN
  END SUBROUTINE SimSimpleFan

  SUBROUTINE SimVariableVolumeFan(FanNum)

      ! SUBROUTINE INFORMATION:
      ! AUTHOR Unknown
      ! DATE WRITTEN Unknown
      ! MODIFIED Phil Haves
      ! RE-ENGINEERED na

      ! PURPOSE OF THIS SUBROUTINE:
      ! This subroutine simulates the simple variable volume fan.

      ! METHODOLOGY EMPLOYED:
      ! Converts design pressure rise and efficiency into fan power and temperature rise
      ! Constant fan pressure rise is assumed.
      ! Uses curves of fan power fraction vs. fan part load to determine fan power at
      ! off design conditions.

```

```

! REFERENCES:
! ASHRAE HVAC 2 Toolkit, page 2-3 (FANSIM)

! USE STATEMENTS:
! na

IMPLICIT NONE      ! Enforce explicit typing of all variables in this routine

! SUBROUTINE ARGUMENT DEFINITIONS:
Integer, Intent(IN) :: FanNum

! SUBROUTINE PARAMETER DEFINITIONS:
! na

! INTERFACE BLOCK SPECIFICATIONS
! na

! DERIVED TYPE DEFINITIONS
! na

! SUBROUTINE LOCAL VARIABLE DECLARATIONS:
Real RhoAir
Real DeltaPress  ! [N/M^2 = Pa]
Real FanEff      ! Total fan efficiency - combined efficiency of fan, drive train,
                ! motor and variable speed controller (if any)
Real MassFlow    ! [kg/sec]
Real Tin         ! [C]
Real Win
Real PartLoadFrac
REAL MaxFlowFrac !Variable Volume Fan Max Flow Fraction [-]
REAL MinFlowFrac !Variable Volume Fan Min Flow Fraction [-]
REAL FlowFrac    !Variable Volume Fan Flow Fraction [-]
Real FanShaftPower ! power delivered to fan shaft
Real PowerLossToAir ! fan and motor loss to air stream (watts)

! Simple Variable Volume Fan - default values from DOE-2
! Type of Fan      Coeff1      Coeff2      Coeff3      Coeff4      Coeff5
! INLET VANE DAMPERS  0.35071223  0.30850535  -0.54137364  0.87198823  0.000
! DISCHARGE DAMPERS  0.37073425  0.97250253  -0.34240761  0.000       0.000
! VARIABLE SPEED MOTOR 0.0015302446 0.0052080574 1.1086242  -0.11635563 0.000

DeltaPress = Fan(FanNum)%DeltaPress
FanEff      = Fan(FanNum)%FanEff

Tin         = Fan(FanNum)%InletAirTemp
Win         = Fan(FanNum)%InletAirHumRat
RhoAir      = Fan(FanNum)%RhoAirStdInit
MassFlow    = MIN(Fan(FanNum)%InletAirMassFlowRate, Fan(FanNum)%MaxAirMassFlowRate)
! MassFlow   = MAX(MassFlow, Fan(FanNum)%MinAirMassFlowRate)

! Calculate and check limits on fraction of system flow
MaxFlowFrac = 1.0
! MinFlowFrac is calculated from the ration of the volume flows and is non-dimensional
MinFlowFrac = Fan(FanNum)%MinAirFlowRate/Fan(FanNum)%MaxAirFlowRate
! The actual flow fraction is calculated from MassFlow and the MaxVolumeFlow * AirDensity
FlowFrac = MassFlow/(Fan(FanNum)%MaxAirMassFlowRate)

! Calculate the part Load Fraction (PH 7/13/03)

FlowFrac = MAX(MinFlowFrac, MIN(FlowFrac, 1.0)) ! limit flow fraction to allowed range

PartLoadFrac = Fan(FanNum)%FanCoeff(1) + Fan(FanNum)%FanCoeff(2)*FlowFrac + &
              Fan(FanNum)%FanCoeff(3)*FlowFrac**2 + Fan(FanNum)%FanCoeff(4)*FlowFrac**3 + &
              Fan(FanNum)%FanCoeff(5)*FlowFrac**4

! Determine the Fan Schedule for the Time step
If( ( GetCurrentScheduleValue(Fan(FanNum)%SchedPtr) > 0.0 .and. Massflow > 0.0 .or. TurnFansOn .and.
Massflow > 0.0) &
.and. .NOT.TurnFansOff ) Then

```



```

!Fan is operating - calculate power loss and enthalpy rise
!   Fan(FanNum)%FanPower = PartLoadFrac*FullMassFlow*DeltaPress/(FanEff*RhoAir) ! total fan power
!   Fan(FanNum)%FanPower = PartLoadFrac*Fan(FanNum)%MaxAirMassFlowRate*DeltaPress/(FanEff*RhoAir) !
total fan power (PH 7/13/03)
  FanShaftPower = Fan(FanNum)%MotEff * Fan(FanNum)%FanPower ! power delivered to shaft
  PowerLossToAir = FanShaftPower + (Fan(FanNum)%FanPower - FanShaftPower) *
Fan(FanNum)%MotInAirFrac
  Fan(FanNum)%OutletAirEnthalpy = Fan(FanNum)%InletAirEnthalpy + PowerLossToAir/MassFlow
! This fan does not change the moisture or Mass Flow across the component
  Fan(FanNum)%OutletAirHumRat      = Fan(FanNum)%InletAirHumRat
  Fan(FanNum)%OutletAirMassFlowRate = MassFlow
  Fan(FanNum)%OutletAirTemp =
PsyTdbFnHW(Fan(FanNum)%OutletAirEnthalpy, Fan(FanNum)%OutletAirHumRat)
Else
!Fan is off and not operating no power consumed and mass flow rate.
  Fan(FanNum)%FanPower = 0.0
  FanShaftPower = 0.0
  PowerLossToAir = 0.0
  Fan(FanNum)%OutletAirMassFlowRate = 0.0
  Fan(FanNum)%OutletAirHumRat      = Fan(FanNum)%InletAirHumRat
  Fan(FanNum)%OutletAirEnthalpy    = Fan(FanNum)%InletAirEnthalpy
  Fan(FanNum)%OutletAirTemp = Fan(FanNum)%InletAirTemp
! Set the Control Flow variables to 0.0 flow when OFF.
  Fan(FanNum)%MassFlowRateMaxAvail = 0.0
  Fan(FanNum)%MassFlowRateMinAvail = 0.0
End If

RETURN
END SUBROUTINE SimVariableVolumeFan

SUBROUTINE SimOnOffFan(FanNum)

! SUBROUTINE INFORMATION:
!   AUTHOR      Unknown
!   DATE WRITTEN Unknown
!   MODIFIED    Shirey, May 2001
!   RE-ENGINEERED na

! PURPOSE OF THIS SUBROUTINE:
! This subroutine simulates the simple on/off fan.

! METHODOLOGY EMPLOYED:
! Converts design pressure rise and efficiency into fan power and temperature rise
! Constant fan pressure rise is assumed.
! Uses curves of fan power fraction vs. fan part load to determine fan power at
! off design conditions.
! Same as simple (constant volume) fan, except added part-load curve input

! REFERENCES:
! ASHRAE HVAC 2 Toolkit, page 2-3 (FANSIM)

! USE STATEMENTS:
USE CurveManager, ONLY: CurveValue

IMPLICIT NONE      ! Enforce explicit typing of all variables in this routine

! SUBROUTINE ARGUMENT DEFINITIONS:
Integer, Intent(IN) :: FanNum

! SUBROUTINE PARAMETER DEFINITIONS:
! na

! INTERFACE BLOCK SPECIFICATIONS
! na

! DERIVED TYPE DEFINITIONS
! na

! SUBROUTINE LOCAL VARIABLE DECLARATIONS:
Real RhoAir
Real DeltaPress ! [N/M^2]

```

```

Real FanEff
Real MassFlow      ! [kg/sec]
Real Tin           ! [C]
Real Win
Real PartLoadRatio !Ratio of actual mass flow rate to max mass flow rate
REAL FlowFrac      !Actual Fan Flow Fraction = actual mass flow rate / max air mass flow
rate
Real FanShaftPower ! power delivered to fan shaft
Real PowerLossToAir ! fan and motor loss to air stream (watts)

DeltaPress = Fan(FanNum)%DeltaPress
FanEff      = Fan(FanNum)%FanEff

Tin         = Fan(FanNum)%InletAirTemp
Win         = Fan(FanNum)%InletAirHumRat
RhoAir      = Fan(FanNum)%RhoAirStdInit
MassFlow    = MIN(Fan(FanNum)%InletAirMassFlowRate, Fan(FanNum)%MaxAirMassFlowRate)
MassFlow    = MAX(MassFlow, Fan(FanNum)%MinAirMassFlowRate)
Fan(FanNum)%FanRuntimeFraction = 0.0

! The actual flow fraction is calculated from MassFlow and the MaxVolumeFlow * AirDensity
FlowFrac = MassFlow/(Fan(FanNum)%MaxAirMassFlowRate)

! Calculate the part load ratio, can't be greater than 1
PartLoadRatio= MIN(1.0,FlowFrac)
! Determine the Fan Schedule for the Time step
IF( ( GetCurrentScheduleValue(Fan(FanNum)%SchedPtr)>0.0 .and. Massflow>0.0 .or. TurnFansOn .and.
Massflow>0.0) &
.and. .NOT.TurnFansOff ) THEN
! Fan is operating
IF (OnOffFanPartLoadFraction <= 0.0) THEN
CALL ShowWarningError('FAN:SIMPLE:ONOFF, OnOffFanPartLoadFraction <= 0.0, Reset to 1.0')
OnOffFanPartLoadFraction = 1.0 ! avoid divide by zero or negative PLF
END IF

IF (OnOffFanPartLoadFraction < 0.7) THEN
OnOffFanPartLoadFraction = 0.7 ! a warning message is already issued from the DX coils or
gas heating coil
END IF
! Keep fan runtime fraction between 0.0 and 1.0
Fan(FanNum)%FanRuntimeFraction = MAX(0.0,MIN(1.0,PartLoadRatio/OnOffFanPartLoadFraction))
! Fan(FanNum)%FanPower = MassFlow*DeltaPress/(FanEff*RhoAir*OnOffFanPartLoadFraction)! total
fan power
Fan(FanNum)%FanPower =
Fan(FanNum)%MaxAirMassFlowRate*Fan(FanNum)%FanRuntimeFraction*DeltaPress/(FanEff*RhoAir)!total fan
power
! OnOffFanPartLoadFraction is passed via DataHVACGlobals from the cooling or heating coil that
is
! requesting the fan to operate in cycling fan/cycling coil mode
OnOffFanPartLoadFraction = 1.0 ! reset to 1 in case other on/off fan is called without a part
load curve
FanShaftPower = Fan(FanNum)%MotEff * Fan(FanNum)%FanPower ! power delivered to shaft
PowerLossToAir = FanShaftPower + (Fan(FanNum)%FanPower - FanShaftPower) *
Fan(FanNum)%MotInAirFrac
Fan(FanNum)%OutletAirEnthalpy = Fan(FanNum)%InletAirEnthalpy + PowerLossToAir/MassFlow
! This fan does not change the moisture or Mass Flow across the component
Fan(FanNum)%OutletAirHumRat      = Fan(FanNum)%InletAirHumRat
Fan(FanNum)%OutletAirMassFlowRate = MassFlow
! Fan(FanNum)%OutletAirTemp = Tin + PowerLossToAir/(MassFlow*PsyCpAirFnWTdb(Win,Tin))
Fan(FanNum)%OutletAirTemp =
PsyTdbFnHW(Fan(FanNum)%OutletAirEnthalpy, Fan(FanNum)%OutletAirHumRat)
ELSE
! Fan is off and not operating no power consumed and mass flow rate.
Fan(FanNum)%FanPower = 0.0
FanShaftPower = 0.0
PowerLossToAir = 0.0
Fan(FanNum)%OutletAirMassFlowRate = 0.0
Fan(FanNum)%OutletAirHumRat      = Fan(FanNum)%InletAirHumRat
Fan(FanNum)%OutletAirEnthalpy    = Fan(FanNum)%InletAirEnthalpy
Fan(FanNum)%OutletAirTemp = Fan(FanNum)%InletAirTemp
! Set the Control Flow variables to 0.0 flow when OFF.

```

```

Fan(FanNum)%MassFlowRateMaxAvail = 0.0
Fan(FanNum)%MassFlowRateMinAvail = 0.0
END IF

```

```

RETURN

```

```

END SUBROUTINE SimOnOffFan

```

```

SUBROUTINE SimZoneExhaustFan(FanNum)

```

```

! SUBROUTINE INFORMATION:
!   AUTHOR          Fred Buhl
!   DATE WRITTEN   Jan 2000
!   MODIFIED      na
!   RE-ENGINEERED na

! PURPOSE OF THIS SUBROUTINE:
! This subroutine simulates the Zone Exhaust Fan

! METHODOLOGY EMPLOYED:
! Converts design pressure rise and efficiency into fan power and temperature rise
! Constant fan pressure rise is assumed.

! REFERENCES:
! ASHRAE HVAC 2 Toolkit, page 2-3 (FANSIM)

! USE STATEMENTS:
! na

```

```

IMPLICIT NONE      ! Enforce explicit typing of all variables in this routine

```

```

! SUBROUTINE ARGUMENT DEFINITIONS:
Integer, Intent(IN) :: FanNum

```

```

! SUBROUTINE PARAMETER DEFINITIONS:
! na

```

```

! INTERFACE BLOCK SPECIFICATIONS
! na

```

```

! DERIVED TYPE DEFINITIONS
! na

```

```

! SUBROUTINE LOCAL VARIABLE DECLARATIONS:
Real RhoAir
Real DeltaPress ! [N/M^2]
Real FanEff
Real MassFlow ! [kg/sec]
Real Tin ! [C]
Real Win
Real PowerLossToAir ! fan and motor loss to air stream (watts)

```

```

DeltaPress = Fan(FanNum)%DeltaPress
FanEff      = Fan(FanNum)%FanEff

```

```

! For a Constant Volume Simple Fan the Max Flow Rate is the Flow Rate for the fan
Tin      = Fan(FanNum)%InletAirTemp
Win      = Fan(FanNum)%InletAirHumRat
RhoAir   = Fan(FanNum)%RhoAirStdInit
MassFlow = Fan(FanNum)%InletAirMassFlowRate
!
! Determine the Fan Schedule for the Time step
If( ( GetCurrentScheduleValue(Fan(FanNum)%SchedPtr)>0.0 .or. TurnFansOn ) &
    .and. .NOT.TurnFansOff ) Then
! Fan is operating
Fan(FanNum)%FanPower = MassFlow*DeltaPress/(FanEff*RhoAir) ! total fan power
PowerLossToAir = Fan(FanNum)%FanPower
Fan(FanNum)%OutletAirEnthalpy = Fan(FanNum)%InletAirEnthalpy + PowerLossToAir/MassFlow
! This fan does not change the moisture or Mass Flow across the component
Fan(FanNum)%OutletAirHumRat = Fan(FanNum)%InletAirHumRat
Fan(FanNum)%OutletAirMassFlowRate = MassFlow

```

```

    Fan(FanNum)%OutletAirTemp =
    PsyTdbFnHW(Fan(FanNum)%OutletAirEnthalpy, Fan(FanNum)%OutletAirHumRat)
Else
    !Fan is off and not operating no power consumed and mass flow rate.
    Fan(FanNum)%FanPower = 0.0
    PowerLossToAir = 0.0
    Fan(FanNum)%OutletAirMassFlowRate = 0.0
    Fan(FanNum)%OutletAirHumRat      = Fan(FanNum)%InletAirHumRat
    Fan(FanNum)%OutletAirEnthalpy    = Fan(FanNum)%InletAirEnthalpy
    Fan(FanNum)%OutletAirTemp = Fan(FanNum)%InletAirTemp
    ! Set the Control Flow variables to 0.0 flow when OFF.
    Fan(FanNum)%MassFlowRateMaxAvail = 0.0
    Fan(FanNum)%MassFlowRateMinAvail = 0.0
    Fan(FanNum)%InletAirMassFlowRate = 0.0

End If

RETURN
END SUBROUTINE SimZoneExhaustFan

! End Algorithm Section of the Module
! *****

! Beginning of Update subroutines for the Fan Module
! *****

SUBROUTINE UpdateFan (FanNum)

    ! SUBROUTINE INFORMATION:
    !     AUTHOR      Richard Liesen
    !     DATE WRITTEN April 1998
    !     MODIFIED    na
    !     RE-ENGINEERED na

    ! PURPOSE OF THIS SUBROUTINE:
    ! This subroutine updates the fan outlet nodes.

    ! METHODOLOGY EMPLOYED:
    ! Data is moved from the fan data structure to the fan outlet nodes.

    ! REFERENCES:
    ! na

    ! USE STATEMENTS:
    ! na

IMPLICIT NONE      ! Enforce explicit typing of all variables in this routine

    ! SUBROUTINE ARGUMENT DEFINITIONS:
    Integer, Intent(IN) :: FanNum

    ! SUBROUTINE PARAMETER DEFINITIONS:
    ! na

    ! INTERFACE BLOCK SPECIFICATIONS
    ! na

    ! DERIVED TYPE DEFINITIONS
    ! na

    ! SUBROUTINE LOCAL VARIABLE DECLARATIONS:
    Integer      :: OutletNode
    Integer      :: InletNode

    OutletNode = Fan(FanNum)%OutletNodeNum
    InletNode = Fan(FanNum)%InletNodeNum

    ! Set the outlet air nodes of the fan
    Node(OutletNode)%MassFlowRate = Fan(FanNum)%OutletAirMassFlowRate

```

```

Node(OutletNode)%Temp          = Fan(FanNum)%OutletAirTemp
Node(OutletNode)%HumRat       = Fan(FanNum)%OutletAirHumRat
Node(OutletNode)%Enthalpy     = Fan(FanNum)%OutletAirEnthalpy
! Set the outlet nodes for properties that just pass through & not used
Node(OutletNode)%Quality      = Node(InletNode)%Quality
Node(OutletNode)%Press        = Node(InletNode)%Press

! Set the Node Flow Control Variables from the Fan Control Variables
Node(OutletNode)%MassFlowRateMaxAvail = Fan(FanNum)%MassFlowRateMaxAvail
Node(OutletNode)%MassFlowRateMinAvail = Fan(FanNum)%MassFlowRateMinAvail

IF (Fan(FanNum)%FanType .EQ. 'ZONE EXHAUST FAN') THEN
  Node(InletNode)%MassFlowRate = Fan(FanNum)%InletAirMassFlowRate
END IF

RETURN
END Subroutine UpdateFan

!           End of Update subroutines for the Fan Module
! *****

! Beginning of Reporting subroutines for the Fan Module
! *****

SUBROUTINE ReportFan (FanNum)

! SUBROUTINE INFORMATION:
!   AUTHOR           Richard Liesen
!   DATE WRITTEN    April 1998
!   MODIFIED        na
!   RE-ENGINEERED   na

! PURPOSE OF THIS SUBROUTINE:
! This subroutine updates the report variables for the fans.

! METHODOLOGY EMPLOYED:
! na

! REFERENCES:
! na

! USE STATEMENTS:
Use DataHVACGlobals, ONLY: TimeStepSys, FanElecPower

IMPLICIT NONE      ! Enforce explicit typing of all variables in this routine

! SUBROUTINE ARGUMENT DEFINITIONS:
Integer, Intent(IN) :: FanNum

! SUBROUTINE PARAMETER DEFINITIONS:
! na

! INTERFACE BLOCK SPECIFICATIONS
! na

! DERIVED TYPE DEFINITIONS
! na

! SUBROUTINE LOCAL VARIABLE DECLARATIONS:
! na

Fan(FanNum)%FanEnergy=Fan(FanNum)%FanPower*TimeStepSys*3600
Fan(FanNum)%DeltaTemp=Fan(FanNum)%OutletAirTemp - Fan(FanNum)%InletAirTemp
FanElecPower = Fan(FanNum)%FanPower

RETURN
END Subroutine ReportFan

!           End of Reporting subroutines for the Fan Module
! *****

```

```

! Beginning of Utility subroutines for the Fan Module
! *****
FUNCTION GetFanDesignVolumeFlowRate (FanType, FanName, ErrorsFound) RESULT (DesignVolumeFlowRate)

    ! FUNCTION INFORMATION:
    !     AUTHOR      Linda Lawrie
    !     DATE WRITTEN February 2006
    !     MODIFIED    na
    !     RE-ENGINEERED na

    ! PURPOSE OF THIS FUNCTION:
    ! This function looks up the design volume flow rate for the given fan and returns it.
If
    ! incorrect fan type or name is given, errorsfound is returned as true and value is
returned
    ! as negative.

    ! METHODOLOGY EMPLOYED:
    ! na

    ! REFERENCES:
    ! na

    ! USE STATEMENTS:
USE InputProcessor, ONLY: FindItemInList

IMPLICIT NONE ! Enforce explicit typing of all variables in this routine

    ! FUNCTION ARGUMENT DEFINITIONS:
CHARACTER(len=*), INTENT(IN) :: FanType      ! must match fan types in this module
CHARACTER(len=*), INTENT(IN) :: FanName     ! must match fan names for the fan type
LOGICAL, INTENT(INOUT)      :: ErrorsFound ! set to true if problem
REAL                        :: DesignVolumeFlowRate ! returned flow rate of matched fan

    ! FUNCTION PARAMETER DEFINITIONS:
    ! na

    ! INTERFACE BLOCK SPECIFICATIONS:
    ! na

    ! DERIVED TYPE DEFINITIONS:
    ! na

    ! FUNCTION LOCAL VARIABLE DECLARATIONS:
INTEGER :: WhichFan

! Obtains and Allocates fan related parameters from input file
IF (GetFanInputFlag) THEN !First time subroutine has been entered
    CALL GetFanInput
    GetFanInputFlag=.false.
End If

WhichFan=FindItemInList (FanName, Fan%FanName, NumFans)
IF (WhichFan /= 0) THEN
    DesignVolumeFlowRate=Fan(WhichFan)%MaxAirFlowRate
ENDIF

IF (WhichFan == 0) THEN
    CALL ShowSevereError('Could not find FanType="//TRIM(FanType)//" with
Name="//TRIM(FanName)//"')
    ErrorsFound=.true.
    DesignVolumeFlowRate=-1000.
ENDIF

RETURN

END FUNCTION GetFanDesignVolumeFlowRate

FUNCTION GetFanInletNode (FanType, FanName, ErrorsFound) RESULT (NodeNumber)

    ! FUNCTION INFORMATION:

```

```

!      AUTHOR      Linda Lawrie
!      DATE WRITTEN February 2006
!      MODIFIED    na
!      RE-ENGINEERED na

! PURPOSE OF THIS FUNCTION:
! This function looks up the given fan and returns the inlet node.  If
! incorrect fan type or name is given, errorsfound is returned as true and value is
returned
! as zero.

! METHODOLOGY EMPLOYED:
! na

! REFERENCES:
! na

! USE STATEMENTS:
USE InputProcessor, ONLY: FindItemInList

IMPLICIT NONE ! Enforce explicit typing of all variables in this routine

! FUNCTION ARGUMENT DEFINITIONS:
CHARACTER(len=*), INTENT(IN) :: FanType      ! must match fan types in this module
CHARACTER(len=*), INTENT(IN) :: FanName     ! must match fan names for the fan type
LOGICAL, INTENT(INOUT)      :: ErrorsFound ! set to true if problem
INTEGER                      :: NodeNumber  ! returned outlet node of matched fan

! FUNCTION PARAMETER DEFINITIONS:
! na

! INTERFACE BLOCK SPECIFICATIONS:
! na

! DERIVED TYPE DEFINITIONS:
! na

! FUNCTION LOCAL VARIABLE DECLARATIONS:
INTEGER :: WhichFan

! Obtains and Allocates fan related parameters from input file
IF (GetFanInputFlag) THEN !First time subroutine has been entered
  CALL GetFanInput
  GetFanInputFlag=.false.
End If

WhichFan=FindItemInList (FanName,Fan%FanName,NumFans)
IF (WhichFan /= 0) THEN
  NodeNumber=Fan(WhichFan)%InletNodeNum
ENDIF

IF (WhichFan == 0) THEN
  CALL ShowSevereError('Could not find FanType="//TRIM(FanType)//" with
Name="//TRIM(FanName)//"')
  ErrorsFound=.true.
  NodeNumber=0
ENDIF

RETURN

END FUNCTION GetFanInletNode

FUNCTION GetFanOutletNode (FanType, FanName, ErrorsFound) RESULT (NodeNumber)

! FUNCTION INFORMATION:
!      AUTHOR      Linda Lawrie
!      DATE WRITTEN February 2006
!      MODIFIED    na
!      RE-ENGINEERED na

! PURPOSE OF THIS FUNCTION:

```

```

! This function looks up the given fan and returns the outlet node.  If
! incorrect fan type or name is given, errorsfound is returned as true and value is
returned
! as zero.

! METHODOLOGY EMPLOYED:
! na

! REFERENCES:
! na

! USE STATEMENTS:
USE InputProcessor, ONLY: FindItemInList

IMPLICIT NONE ! Enforce explicit typing of all variables in this routine

! FUNCTION ARGUMENT DEFINITIONS:
CHARACTER(len=*), INTENT(IN) :: FanType      ! must match fan types in this module
CHARACTER(len=*), INTENT(IN) :: FanName     ! must match fan names for the fan type
LOGICAL, INTENT(INOUT)      :: ErrorsFound ! set to true if problem
INTEGER                      :: NodeNumber  ! returned outlet node of matched fan

! FUNCTION PARAMETER DEFINITIONS:
! na

! INTERFACE BLOCK SPECIFICATIONS:
! na

! DERIVED TYPE DEFINITIONS:
! na

! FUNCTION LOCAL VARIABLE DECLARATIONS:
INTEGER :: WhichFan

! Obtains and Allocates fan related parameters from input file
IF (GetFanInputFlag) THEN !First time subroutine has been entered
  CALL GetFanInput
  GetFanInputFlag=.false.
End If

WhichFan=FindItemInList(FanName,Fan%FanName,NumFans)
IF (WhichFan /= 0) THEN
  NodeNumber=Fan(WhichFan)%OutletNodeNum
ENDIF

IF (WhichFan == 0) THEN
  CALL ShowSevereError('Could not find FanType="//TRIM(FanType)//" with
Name="//TRIM(FanName)//"')
  ErrorsFound=.true.
  NodeNumber=0
ENDIF

RETURN

END FUNCTION GetFanOutletNode

! End of Utility subroutines for the Fan Module
! *****

! NOTICE
!
! Copyright © 1996-xxxx The Board of Trustees of the University of Illinois
! and The Regents of the University of California through Ernest Orlando Lawrence
! Berkeley National Laboratory. All rights reserved.
!
! Portions of the EnergyPlus software package have been developed and copyrighted
! by other individuals, companies and institutions. These portions have been
! incorporated into the EnergyPlus software package under license. For a complete
! list of contributors, see "Notice" located in EnergyPlus.f90.
!
! NOTICE: The U.S. Government is granted for itself and others acting on its

```



```
!   behalf a paid-up, nonexclusive, irrevocable, worldwide license in this data to
!   reproduce, prepare derivative works, and perform publicly and display publicly.
!   Beginning five (5) years after permission to assert copyright is granted,
!   subject to two possible five year renewals, the U.S. Government is granted for
!   itself and others acting on its behalf a paid-up, non-exclusive, irrevocable
!   worldwide license in this data to reproduce, prepare derivative works,
!   distribute copies to the public, perform publicly and display publicly, and to
!   permit others to do so.
!
!   TRADEMARKS: EnergyPlus is a trademark of the US Department of Energy.
!
```

```
End Module Fans
```

## How it fits together

Although we have designed the EnergyPlus modules to be as independent as possible, obviously they cannot be completely independent. How does an EnergyPlus HVAC module fit in with the rest of the program? First, we will show some subroutine calling trees that will display the overall program structure.

### Top Level Calling Tree

EnergyPlus

- ProcessInput (in InputProcessor)
- ManageSimulation (in SimulationManager)
  - ManageWeather (in WeatherManager)
  - ManageHeatBalance (in HeatBalanceManager)
    - ManageSurfaceHeatBalance (in HeatBalanceSurfaceManager)
    - ManageAirHeatBalance (in HeatBalanceAirManager)
      - CalcHeatBalanceAir (in HeatBalanceAirManager)
        - ManageHVAC (in HVACManager)

The HVAC part of EnergyPlus is divided into a number of simulation blocks. At this point, there are blocks for the air system, the zone equipment, the plant supply, the plant demand, the condenser supply, and the condenser demand. There will be simulation blocks for waste heat supply and usage as well as electricity and gas. Within each HVAC time step, the blocks are simulated repeatedly until the conditions on each side of each block interface match up. The following calling tree represents the high level HVAC simulation structure. It is schematic – not all routines are shown.

### High Level HVAC Calling Tree (schematic – not all routines are shown)

ManageHVAC (in HVACManager)

- ZoneAirUpdate('PREDICT', . . .) (in HVACManager)
  - estimate the zone heating or cooling demand*
- SimHVAC (in HVACManager)
  - ManageSetPoints (in SetPointManager)
  - SimSelectedEquipment (in HVACManager)
    - ManageAirLoops (in SimAirServingZones)
    - ManageZoneEquipment (in ZoneEquipmentManager)
    - ManagePlantSupplySides (in PlantLoopSupplySideManager)
    - ManagePlantDemandSides (in PlantdemandSideLoops)
    - ManageCondSupplySides (in CondLoopManager)
    - ManageCondenserDemandSides (in CondenserDemandSideLoops)
- ZoneAirUpdate('CORRECT', . . .) (in HVACManager)

*From the amount of heating and cooling actually provided by the HVAC system, calculate the zone temperatures.*

Each of the “Manage” routines has a different structure, since the simulation to be performed is different in each case. We will show schematic calling trees for several of the “Manage” routines.

### **Air System Calling Tree (schematic – not all routines are shown)**

ManageAirLoops (in SimAirServingZones)

- GetAirPathData (in SimAirServingZones)
- InitAirLoops (in SimAirServingZones)
- SimAirLoops (in SimAirServingZones)
  - SimAirLoopComponent (in SimAirServingZones)
  - UpdateBranchConnections (in SimAirServingZones)
    - ManageOutsideAirSystem (in MixedAir)
      - SimOutsideAirSys (in MixedAir)
        - SimOAController (in MixedAir)
        - SimOACComponent (in Mixed Air)
          - SimOAMixer (in MixedAir)
          - SimulateFanComponents(in FanSimulation; file HVACFanComponent)
          - SimulateWaterCoilComponents (in WaterCoilSimulation; file HVACWaterCoilComponent)
          - SimHeatRecovery (in HeatRecovery)
          - SimDesiccantDehumidifier (in DesiccantDehumidifiers)
    - SimulateFanComponents (in FanSimulation; file HVACFanComponent)
    - SimulateWaterCoilComponents (in WaterCoilSimulation; file HVACWaterCoilComponent)
    - SimulateHeatingCoilComponents (in HeatingCoils; file HVACHeatingCoils)
    - SimDXCoolingSystem (in HVACDXSystem)
    - SimFurnace (in Furnaces; file HVACFurnace)
    - SimHumidifier (in Humidifiers)
    - SimEvapCooler (in EvaporativeCoolers; file HVACEvapComponent)
    - SimDesiccantDehumidifier (in DesiccantDehumidifiers)
    - SimHeatRecovery (in HeatRecovery)
  - ManageControllers (in Controllers)
    - GetControllerInput (in Controllers)
    - InitController (in Controllers)
    - SimpleController (in Controllers)
    - LimitController (in Controllers)
    - UpdateController (in Controllers)
    - Report Controller (in Controllers)
  - ResolveSysFlow (in SimAirServingZones)
  - UpdateHVACInterface (in HVACInterfaceManager)
- ReportAirLoops (in SimAirServingZones)

**Plant Supply Calling Tree (schematic – not all routines are shown)**

ManagePlantSupplySides (in PlantLoopSupplySideManager)

- GetLoopData (in PlantLoopSupplySideManager)
- SetLoopInitialConditions (in PlantLoopSupplySideManager)
- CalcLoopDemand (in PlantLoopSupplySideManager)
- ManagePlantLoopOperation (in PlantCondLoopOperation)
- DistributeLoad (in PlantLoopSupplySideManager)
- SimPlantEquip (in PlantLoopSupplySideManager)
  - SimPipes (in Pipes; file PlantPipes)
  - SimPumps (in Pumps; file PlantPumps)
  - SimEngineDrivenChiller (in ChillerEngineDriven ; file PlantChillers)
  - SimBLASTAbsorber (in ChillerAbsorption ; file PlantAbsorptionChillers)
  - SimElectricChiller (in ChillerElectric ; file PlantChillers)
  - SimGTChiller (in ChillerGasTurbine ; file PlantChillers)
  - SimConstCOPChiller (in ChillerConstCOP; file PlantChillers)
  - SimBLASTChiller (in ChillerBLAST ; file PlantChillers)
  - SimOutsideCooling (in OutsideCoolingSources ; file PlantOutsideCoolingSources)
  - SimGasAbsorber (in ChillerGasAbsorption ; file PlantGasAbsorptionChiller)
  - SimBoiler (in Boilers; file PlantBoilers)
  - SimWaterHeater (in WaterHeaters ; file PlantWaterHeater)
  - SimOutsideHeating (in OutsideHeatingSources; file PlantOutsideHeatingSources)
- UpdateSplitter (in PlantLoopSupplySideManager)
- SolveFlowNetwork (in PlantLoopSupplySideManager)
- CalcLoopDemand (in PlantLoopSupplySideManager)
- SimPlantEquip (in PlantLoopSupplySideManager)
- UpdateSplitter
- UpdateMixer (in PlantLoopSupplySideManager)
- SimPlantEquip (in PlantLoopSupplySideManager)
- CheckLoopExitNodes (in PlantLoopSupplySideManager)
- UpdateHVACInterface (in HVACInterfaceManager)
- UpdateReportVars (in PlantLoopSupplySideManager)

**Zone Equipment Calling Tree (schematic – not all routines are shown)**

ManageZoneEquipment (in ZoneEquipmentManager)

- GetZoneEquipment (in ZoneEquipmentManager)
- InitZoneEquipment (in ZoneEquipmentManager)
- SimZoneEquioment (in ZoneEquipmentManager)
  - SimAirLoopSplitter (in Splitters; file HVACSplitterComponent)
  - SimAirZonePlenum (in ZonePlenum; file ZonePlenumComponent)
  - SetZoneEquipSimOrder (in ZoneEquipmentManager)
  - InitSystemOutputRequired (in ZoneEquipmentManager)
  - ManageZoneAirLoopEquipment (in ZoneAirLoopEquipmentManager)
    - GetZoneAirLoopEquipment (in ZoneAirLoopEquipmentManager)

- SimZoneAirLoopEquipment (in ZoneAirLoopEquipmentManager)
  - SimulateDualDuct (in DualDuct; file HVACDualDuctSystem)
    - GetDualDuctInput (in DualDuct; file HVACDualDuctSystem)
    - InitDualDuct (in DualDuct; file HVACDualDuctSystem)
    - SimDualDuctConstVol (in DualDuct; file HVACDualDuctSystem)
    - SimDualDuctVarVol (in DualDuct; file HVACDualDuctSystem)
    - UpdateDualDuct (in DualDuct; file HVACDualDuctSystem)
    - ReportDualDuct (in DualDuct; file HVACDualDuctSystem)
  - SimulateSingleDuct (in SingleDuct; file HVACSingeDuctSystem)
    - GetSysInput (in SingleDuct; file HVACSingeDuctSystem)
    - InitSys (in SingleDuct; file HVACSingeDuctSystem)
    - SimConstVol (in SingleDuct; file HVACSingeDuctSystem)
    - SimVAV (in SingleDuct; file HVACSingeDuctSystem)
    - ReportSys (in SingleDuct; file HVACSingeDuctSystem)
  - SimPIU (in PoweredInductionUnits)
    - GetPIUs (in PoweredInductionUnits)
    - InitPIUs (in PoweredInductionUnits)
    - CalcSeriesPIU (in PoweredInductionUnits)
    - CalcParallelPIU (in PoweredInductionUnits)
    - ReportPIU (in PoweredInductionUnits)
- SimDirectAir (in DirectAirManager; file DirectAir)
- SimPurchasedAir (in PurchasedAirManager)
- SimWindowAC (in WindowAC)
- SimFanCoilUnit (in FanCoilUnits)
- SimUnitVentilator (in UnitVentilator)
- SimUnitHeater (in UnitHeater)
- SimBaseboard (in BaseboardRadiator)
- SimHighTempRadiantSystem (in HighTempRadiantSystem; file RadiantSystemHighTemp)
- SimLowTempRadiantSystem (in LowTempRadiantSystem; file RadiantSystemLowTemp)
- SimulateFanComponents (in Fans; file HVACFanComponent)
- SimHeatRecovery (in HeatRecovery)
- UpdateSystemOutputRequired (in ZoneEquipmentManager)
- SimAirLoopSplitter (in Splitters; file HVACSplitterComponent)
- SimAirZonePlenum (in ZonePlenum; file ZonePlenumComponent)
- CalcZoneMassBalance (in ZoneEquipmentManager)
- CalcZoneLeavingConditions (in ZoneEquipmentManager)
- SimReturnAirPath (in ReturnAirPathManager; file ReturnAirPath)
  - SimAirMixer (in Mixers; HVACMixerComponent)
  - SimAirZonePlenum (in ZonePlenum; file ZonePlenumComponent)
- RecordZoneEquipment (in ZoneEquipmentManager)
- ReportZoneEquipment (in ZoneEquipmentManager)

### Inserting the New Module into the Program

Let us return to our example new module NewHVACComponent. Since the module gets its own input and output, adding the NewHVACComponent model to the program simply means adding a call to the driver routine SimNewHVACComponent from the correct place in EnergyPlus. In the simplest case, there is only one location from which the driver routine should

be called. In some cases, though, more than one HVAC simulation block will need to use the new component model. `SimulateWaterCoilComponents`, for instance, can be used in both zone equipment and air systems for heating, reheating and cooling coils. In the air system simulation it is called from two places: the main air system simulation, and the mixed air simulation – the outside air duct might contain a separate cooling coil.

Let us assume that the `NewHVACComponent` will be part of the air system – perhaps it is a solid desiccant wheel. Examining the air system calling tree we see that `SimAirLoopComponent` is one routine that will invoke the new component, and - if we want the component to possibly be in the outside air stream – then `SimOACComponent` is the other routine that will need to call the new component simulation. Generally, all that is involved is adding a new `CASE` statement to a Fortran `SELECT` construct. For instance in `SimAirLoopComponent` this would look like:

```

SELECT CASE (CompType_Num)

  CASE (OAMixer_Num) ! 'OUTSIDE AIR SYSTEM'
    CALL ManageOutsideAirSystem( ...)

! Fan Types for the air sys simulation
  CASE (Fan_Simple_CV) ! 'FAN:SIMPLE:CONSTVOLUME'
    CALL SimulateFanComponents(...)

  CASE (Fan_Simple_VAV) ! 'FAN:SIMPLE:VARIABLEVOLUME'
    CALL SimulateFanComponents(...)

! Coil Types for the air sys simulation
!
!           'COIL:DX:COOLINGHEATEXCHANGERASSISTED'
  CASE (DXCoil_CoolingHXAsst)
    CALL SimHXAssistedCoolingCoil(...)
!
!           'COIL:WATER:COOLINGHEATEXCHANGERASSISTED'
  CASE (WaterCoil_CoolingHXAsst)
    CALL SimHXAssistedCoolingCoil(...)
  CASE (WaterCoil_SimpleHeat) ! 'COIL:WATER:SIMPLEHEATING'
    CALL SimulateWaterCoilComponents(...)
  CASE (SteamCoil_AirHeat) ! 'COIL:STEAM:AIRHEATING'
    CALL SimulateSteamCoilComponents(...)
  CASE (WaterCoil_DetailedCool) ! 'COIL:WATER:DETAILEDFLATCOOLING'
    CALL SimulateWaterCoilComponents(...)
  CASE (WaterCoil_Cooling) ! 'COIL:WATER:COOLING'
    CALL SimulateWaterCoilComponents(...)
  CASE (Coil_ElectricHeat) ! 'COIL:ELECTRIC:HEATING'
    CALL SimulateHeatingCoilComponents(...)
  CASE (Coil_GasHeat) ! 'COIL:GAS:HEATING'
    CALL SimulateHeatingCoilComponents(...)

! Heat reclaim
  CASE (Coil_DeSuperHeat) ! 'COIL:DESUPERHEATER:HEATING'
    CALL SimulateHeatingCoilComponents(...)

  CASE (DXSystem) ! 'DXSYSTEM:AIRLOOP'
    CALL SimDXCoolingSystem(...)

  CASE (Furnace_UnitarySys) ! 'FURNACE:BLOWTHRU:HEATONLY',
                           ! 'FURNACE:BLOWTHRU:HEATCOOL',
                           ! 'UNITARYSYSTEM:BLOWTHRU:HEATONLY',
                           ! 'UNITARYSYSTEM:BLOWTHRU:HEATCOOL'
                           ! 'UNITARYSYSTEM:HEATPUMP:AIRTOAIR',
                           ! 'UNITARYSYSTEM:HEATPUMP:WATERTOAIR'

```

```

CALL SimFurnace(...)

! Humidifier Types for the air system simulation
CASE(Humidifier) ! 'HUMIDIFIER:STEAM:ELECTRICAL'
  CALL SimHumidifier(...)

! Evap Cooler Types for the air system simulation
CASE(EvapCooler) ! 'EVAPCOOLER:DIRECT:CELDEKPAD',
                 ! 'EVAPCOOLER:INDIRECT:CELDEKPAD'
                 ! 'EVAPCOOLER:INDIRECT:WETCOIL',
                 ! 'EVAPCOOLER:INDIRECT:RDDSPECIAL'
  CALL SimEvapCooler(...)

! Desiccant Dehumidifier Types for the air system simulation
CASE(Desiccant) ! 'DESICCANT DEHUMIDIFIER:SOLID'
  CALL SimDesiccantDehumidifier(...)

! Heat recovery
CASE(HeatXchngr) ! 'HEAT EXCHANGER:AIR TO AIR:FLAT PLATE'
  CALL SimHeatRecovery(...)

! Ducts
CASE(Duct) ! 'DUCT'
  CALL SimDuct(...)

! New HVAC Component
CASE(NewHVACCompNum) ! 'NEW HVAC COMPONENT'
  CALL SimNewHVACComponent(...)

DEFAULT

END SELECT

```

The new code is italicized. Do the same thing in SimOAComponent and you are done! Note that “NEW HVAC COMPONENT” is the class name (keyword) for the new component in the IDD file. The class names are converted to upper case in EnergyPlus, so the CASE statement must have the class name in upper case. The actual class name on the IDD file would probably be “New HVAC Component”.

If the new HVAC component is a piece of zone equipment – a cooled beam system, for instance – then the zone equipment calling tree indicates that the call to SimNewHVACComponent would be in SimZoneEquipment. If the new component is a gas fired absorption chiller, the call would be in SimPlantEquip.

In every case, since NewHVACComponent is a new module, a USE statement must be added to the calling subroutine. For instance in SimAirLoopComponent this would look like:

```

SUBROUTINE SimAirLoopComponent(CompType, CompName, FirstHVACIteration,
LastSim)

    ! SUBROUTINE INFORMATION
    !           AUTHOR: Russ Taylor, Dan Fisher, Fred Buhl
    !           DATE WRITTEN: Oct 1997
    !           MODIFIED: Dec 1997 Fred Buhl
    !           RE-ENGINEERED: This is new code, not reengineered

    ! PURPOSE OF THIS SUBROUTINE:

```

```

! Calls the individual air loop component simulation
routines

! METHODOLOGY EMPLOYED: None

! REFERENCES: None

! USE Statements
USE Fans,          Only:SimulateFanComponents
USE WaterCoils,   Only:SimulateWaterCoilComponents
USE MixedAir,     Only:ManageOutsideAirSystem
USE NewHVACComponent, Only:SimNewHVACComponent

```

## Changing existing code

It may be that your new module or your new feature impacts existing code. Should that happen, follow the guidance in the Programming Standard about positioning of “global data”. Likewise, any code written should follow the guidance outlined in the Programming Standard.

## Considerations for Legacy Codes

Those module developers who are adding to EnergyPlus’s capabilities by adapting existing codes into the module structure should take special considerations.

**First and foremost, who owns the legacy code that you are adapting? More on this is covered in Appendix C – Submissions and Check-ins. One must be very careful when developing modules to be implemented in the publicly-available version of EnergyPlus.**

Legacy codes will typically come with their own input and output structures. In adapting a legacy code to use with EnergyPlus, the module developer will usually want to bypass these routines by embedding the code into EnergyPlus and using input entirely from the IDD/IDF structure. During original transition, you can consider doing a parallel effort of writing a simple input file for the legacy code while testing results with your developing EnergyPlus transition code.

## Code Readability vs. Speed of Execution

Programmers throughout time have had to deal with speed of code execution and it’s an ongoing concern. However, compilers are pretty smart these days and, often, can produce speedier code for the hardware platform than the programmer can when he or she uses “speed up” tips. The EnergyPlus development team would rather the code be more “readable” to all than to try to outwit the compilers for every platform. First and foremost, the code is the true document of what EnergyPlus does – other documents will try to explain algorithms and such but must really take a back seat to the code itself.

However, many people may read the code – as developers, we should try to make it as readable at first glance as possible. For a true example from the code and a general indication of preferred style, take the case of the zone temperature update equation. In the [Engineering Reference](#) document, the form is recognizable and usual:



$$T_z^t = \frac{\sum_{i=1}^{N_{sl}} \dot{Q}_i + \sum_{i=1}^{N_{surfaces}} h_i A_i T_{si} + \sum_{i=1}^{N_{zones}} \dot{m}_i C_p T_{zi} + \dot{m}_{inf} C_p T_{\infty} + \dot{m}_{sys} C_p T_{supply} - \left(\frac{C_z}{\delta t}\right) \left(-3T_z^{t-\delta t} + \frac{3}{2}T_z^{t-2\delta t} - \frac{1}{3}T_z^{t-3\delta t}\right)}{\left(\frac{11}{6}\right)\frac{C_z}{\delta t} + \sum_{i=1}^{N_{surfaces}} h_i A + \sum_{i=1}^{N_{zones}} \dot{m}_i C_p + \dot{m}_{inf} C_p + \dot{m}_{sys} C}$$

And, this equation appears in the code (ZoneTempPredictorCorrector Module), as:

```
ZT(ZoneNum)= (CoefSumhat + CoefAirrat*(3.0*ZTM1(ZoneNum) - (3.0/2.0)*ZTM2(ZoneNum) &
+ (1./3.)* ZTM3(ZoneNum))) &
/ ((11.0/6.0)*CoefAirrat+CoefSumha)
```

Somewhat abbreviated here due to lack of page width but still recognizable from the original. A better version would actually be:

```
ZT(ZoneNum)= (CoefSumhat - CoefAirrat*(-3.0*ZTM1(ZoneNum) + (3.0/2.0)*ZTM2(ZoneNum) &
- (1./3.)* ZTM3(ZoneNum))) &
/ ((11.0/6.0)*CoefAirrat+CoefSumha)
```

Whereas the natural tendency of programming would lead to the less readable:

```
ZT(ZoneNum)= (CoefSumhat + CoefAirrat*(3.0*ZTM1(ZoneNum) - 1.5*ZTM2(ZoneNum) + .333333*
ZTM3(ZoneNum))) &
/ (1.83333*CoefAirrat+CoefSumha)
```

The final version is a correct translation (more or less) from the Engineering/usual representation but much harder to look at in code and realize what is being represented.

### Speed of Execution

**A critical consideration in speed of execution is character string comparisons.** These are typically quite slow and should not be used in the core routines (i.e. those that are executed every zone or hvac time step). An alternative to string comparisons is to define module-level integer parameters, equate a string to a parameter during the initial subroutine call (e.g. GetInput), and then do integer comparisons through the remainder of the calls to the module. Doing this does not deter readability, yet assists in reducing execution time.

For example, in the module shown previously (Module Fans), the parameters for fan types are set as Integers:

```
!MODULE PARAMETER DEFINITIONS
INTEGER, PARAMETER :: FanType_SimpleConstVolume = 1
INTEGER, PARAMETER :: FanType_SimpleVAV = 2
INTEGER, PARAMETER :: FanType_SimpleOnOff = 3
INTEGER, PARAMETER :: FanType_ZoneExhaust = 4
```

During the GetInput, string types are shown (this is getting these objects):

```
CALL GetObjectItem('FAN:SIMPLE:CONSTVOLUME', &
SimpFanNum, AlphArray, &
NumAlphas, NumArray, NumNums, IOSTAT)
. . .
Fan(FanNum)%FanName = AlphArray(1)
Fan(FanNum)%FanType = 'SIMPLE'
. . .
Fan(FanNum)%Control = 'CONSTVOLUME'
Fan(FanNum)%FanType_Num=FanType_SimpleConstVolume
```

Then, during the simulation the integer parameters are used:

```
! Calculate the Correct Fan Model with the current FanNum
```

```
IF (Fan(FanNum)%FanType_Num == FanType_SimpleConstVolume) THEN
  Call SimSimpleFan(FanNum)
Else IF (Fan(FanNum)%FanType_Num == FanType_SimpleVAV) THEN
  Call SimVariableVolumeFan(FanNum)
Else If (Fan(FanNum)%FanType_Num == FanType_SimpleOnOff) THEN
  Call SimOnOffFan(FanNum)
Else If (Fan(FanNum)%FanType_Num == FanType_ZoneExhaust) THEN
  Call SimZoneExhaustFan(FanNum)
End If
```

This does not detract from code readability at all but execution is much speedier with this versus the string comparisons.

## EnergyPlus Services

EnergyPlus provides some standard services that make the developer's task much easier. The developer can concentrate on the new simulation algorithm rather than have to deal with details of input file structure, writing output, obtaining scheduled data, and accessing weather variables.

### Utility Routines/Functions

EnergyPlus supplies an extensive set of routines to help module developers get input, check values, get schedule values, get and check nodes. These are summarized in the following table and in more detail in the following sections. The table indicates the routine/function name, times of most likely use, and the module (if applicable) that you must USE in the code in order to make the routine available to you. Most of the items mentioned in this table are of particular use in "GetInput" processing. A few later tables will highlight similar functions/routines for simulation purposes.

Table 1. Table of Utility Functions

<b>Routine/Function Name</b>	<b>Use during</b>	<b>Module</b>
GetNumObjectsFound	"GetInput" Processing	InputProcessor
GetObjectItem	"GetInput" Processing	InputProcessor
GetObjectDefMaxArgs	"GetInput" Processing	InputProcessor
GetObjectItemNum	"GetInput" Processing	InputProcessor
FindItemInList	"GetInput" Processing (best) though some are currently used in Simulation	InputProcessor
FindItem	"GetInput" Processing	InputProcessor
FindItemInSortedList	"Special processing" – list must be sorted.	InputProcessor
SameString	"GetInput" Processing	InputProcessor
VerifyName	"GetInput" Processing	InputProcessor
RangeCheck	"GetInput" Processing	InputProcessor
MakeUPPERCase	"GetInput" Processing	InputProcessor
GetOnlySingleNode	"GetInput" Processing	NodeInputManager
GetNodeNums	"GetInput" Processing	NodeInputManager
InitUniqueNodeCheck, CheckUniqueNodes, EndUniqueNodeCheck	"GetInput" Processing	NodeInputManager
SetupCompSets	"GetInput" Processing	NodeInputManager
TestCompSets	"GetInput" Processing	NodeInputManager
GetNewUnitNumber	(automatically retrieve an available unit number)	EXTERNAL integer function
FindUnitNumber	Find a unit number when you know the name of the file	EXTERNAL integer function
FindNumberInList	"GetInput" Processing/Init	EXTERNAL integer function

<b>Routine/Function Name</b>	<b>Use during</b>	<b>Module</b>
	processing	
ValidateComponent	“GetInput” Processing	Subroutine CALL
CheckComponent	“GetInput” Processing – like ValidateComponent but doesn’t generate error message if failure	Subroutine CALL
CreateSysTimeIntervalString	Simulation – Error Messages	General
TrimSigDigits	Simulation – Error Messages	General
RoundSigDigits	Simulation – Error Messages	General
GetScheduleIndex	“GetInput” Processing	ScheduleManager
GetDayScheduleIndex	“GetInput” Processing	ScheduleManager
GetCurrentScheduleValue	Simulation	ScheduleManager
GetScheduleValuesForDay	Simulation	ScheduleManager
GetSingleDayScheduleValues	Simulation/”GetInput”	ScheduleManager
CheckScheduleValueMinMax	“GetInput” Processing	ScheduleManager
CheckScheduleValue	“GetInput” Processing	ScheduleManager
GetScheduleMinValue	“GetInput” Processing	ScheduleManager
GetScheduleMaxValue	“GetInput” Processing	ScheduleManager
LookUpScheduleValue	Simulation	ScheduleManager
CheckOutAirNodeNumber	“GetInput” Processing	OutAirNodeManager
GetCurveIndex	“GetInput” Processing	CurveManager
GetCurveCheck	“GetInput” Processing	CurveManager
GetCurveType	“GetInput” Processing	CurveManager
CurveValue	Simulation	CurveManager
SetupAndSort	Sorting lists of character values	SortAndStringUtilities

## Input Services

The module *InputProcessor* processes the input data files (IDFs). It also reads and parses the IDD file. The *InputProcessor* uses the definition lines in the IDD as directives on how to process each input object in the IDF. The *InputProcessor* also turns all alpha strings into all UPPER CASE. Currently, it does nothing else to those strings – so the number of blanks in a string must match what the calculational modules expect. The *InputProcessor* processes all numeric strings into single precision real numbers. Special characters, such as tabs, should *not* be included in the IDF.

The EnergyPlus module *InputProcessor* provides several routines - generically called the “get” routines – that enable the developer to readily access the data for a new module. These routines are made available by including a “USE *InputProcessor*” statement in the module or in the routine that will use the “get” routines. The *GetFanInput* subroutine in the example illustrates some of the uses of the “get” routines.

## InputProcessor

The following objects use public routines from the InputProcessor. To access these, the code has:

```
Use InputProcessor, ONLY: <routine1>, <routine2>
```

Where the <routine> is one or more of the following:

### GetNumObjectsFound

This function returns the number of objects in the input belonging to a particular class. In other terms, it returns the number of instances in the input of a particular component.

Example:

```
USE InputProcessor, ONLY: GetNumObjectsFound
---
NumVAVSys = GetNumObjectsFound('SINGLE DUCT:VAV:REHEAT')
```

Here NumVAVSys will contain the number of single duct VAV terminal units in the input data file (IDF). SINGLE DUCT:VAV:REHEAT is the class name or keyword defining VAV terminal unit input on the IDD file.

### GetObjectItem

This subroutine is used to obtain the actual alphanumeric and numeric data for a particular object.

Example:

```
USE InputProcessor, ONLY: GetNumObjectsFound, GetObjectNum
---
INTEGER :: SysNum
INTEGER :: SysIndex
INTEGER :: NumAlphas
INTEGER :: NumNums
INTEGER :: IOSTAT
REAL, DIMENSION(5) :: NumArray
LOGICAL, DIMENSION(5) :: NumBlank
CHARACTER(len=MaxNameLength), DIMENSION(8) :: AlphArray
. . . . .
! Flow
NumVAVSys = GetNumObjectsFound('SINGLE DUCT:VAV:REHEAT')
. . . . .
!Start Loading the System Input
DO SysIndex = 1, NumVAVSys
  CALL GetObjectItem ('SINGLE DUCT:VAV:REHEAT', SysIndex, AlphArray, &
    NumAlphas, NumArray, NumNums, IOSTAT, NumBlank)
  SysNum = SysIndex
  . . . . .
  Sys(SysNum)%SysName      = AlphArray(1)
  Sys(SysNum)%SysType      = 'SINGLE DUCT:VAV:REHEAT'
  Sys(SysNum)%ReheatComp   = AlphArray(6)
  Sys(SysNum)%ReheatName   = AlphArray(7)
  . . . . .
END DO ! end Number of Sys Loop  END IF
```

Here GetObjectItem is called with inputs 'SINGLE DUCT:VAV:REHEAT' – the class of object we want to input – and SysIndex – the index of the object on the input file. If SysIndex is 3, the call to GetObjectItem will get the data for the third VAV terminal unit on the input file. Output is returned in the

remaining arguments. AlphArray contains in order all the alphanumeric data items for a single VAV terminal unit. NumArray contains all the numeric data items. NumAlphas is the number of alphanumeric items read; NumNums is the number of numeric data items read. IOSTAT is a status flag: -1 means there was an error; +1 means the input was OK. AlphArray and NumArray should be dimensioned to handle the largest expected input for the item. NumBlank is an optional argument to the routine – it can be used to determine if a numeric field was entered as “blank” rather than the filled value of 0.0.

### **GetObjectDefMaxArgs**

#### ***Extensible input techniques***

While developers do their best to guess how many items are needed in an object, users will often want to extend that object with far more fields than were dreamed of. Using Allocatable arrays in Fortran usually makes this feasible, the special `!extensible` field makes it possible.

Example:

```
USE InputProcessor, ONLY: GetObjectDefMaxArgs
---
CHARACTER(len=MaxNameLength), ALLOCATABLE, DIMENSION(:) :: Alphas
REAL, ALLOCATABLE, DIMENSION(:) :: Numbers

! You supply the object word, routine returns numargs, numalpha, numnumeric
CALL GetObjectDefMaxArgs ('DAYSCHEDULE:INTERVAL', NumArgs, NumAlpha, NumNumeric)

ALLOCATE (Alphas (NumAlpha))
ALLOCATE (Numbers (NumNumeric))

! Then, usual get calls...
```

Thus, you can determine how many arguments that the IDD has defined as “maximum” for a given object.

### **GetObjectItemNum**

GetObjectItem, described above, requires the input file index of the desired object in order to get the object’s data. Sometimes this index may be unknown, but the name of the object is known. GetObjectItemNum returns the input file index given the class name and object name.

```
Example:
USE InputProcessor, ONLY: GetObjectItemNum
---
ListNum = GetObjectItemNum ('CONTROLLER LIST', ControllerListName)
```

In the example, ListNum will contain the input file index of the ‘CONTROLLER LIST’ whose name is contained in the string variable ControllerListName.

### **FindItemInList**

This function looks up a string in a similar list of items and returns the index of the item in the list, if found. It is case sensitive.

```
Example:
USE InputProcessor, ONLY: FindItemInList
---
```

```
SysNum = FindItemInList (CompName, Sys%SysName, NumSys)
```

CompName is the input string, Sys%SysName is the list of names to be searched, and NumSys is the size of the list.

### **FindItem**

Case insensitive version of the FindItemInList.

Example:

```
USE InputProcessor, ONLY: FindItem
---
SysNum = FindItem (CompName, Sys%SysName, NumSys)
```

CompName is the input string, Sys%SysName is the list of names to be searched, and NumSys is the size of the list.

### **FindItemInSortedList**

This function looks up a string in a sorted list of items and returns the index of the item in the list, if found. It is case sensitive.

Example:

```
USE InputProcessor, ONLY: FindItemInSortedList
---
SysNum = FindItemInSortedList (CompName, Sys%SysName, NumSys)
```

CompName is the input string, Sys%SysName is the list of names to be searched, and NumSys is the size of the list. See quick sort utility – most lists are NOT sorted in EnergyPlus.

### **SameString**

This function returns true if two strings are equal (case insensitively).

Example:

```
USE InputProcessor, ONLY: SameString
---
IF (SameString (InputRoughness, 'VeryRough')) THEN
    Material (MaterNum) %Roughness=VeryRough
ENDIF
```

### **VerifyName**

This subroutine checks that an object name is unique; that is, it hasn't already been used for the same class of object and the name is not blank.

Example:

```
USE InputProcessor, ONLY: VerifyName
---
CALL VerifyName (AlphaArray(1), Fan%FanName, &
    FanNum-1, IsNotOK, IsBlank, 'FAN:SIMPLE:CONSTVOLUME Name')
```

The first argument is the name to be checked, the second is the list of names to search, the third argument is the number of entries in the list, the 4<sup>th</sup> argument is set to TRUE if verification fails, the 5<sup>th</sup> argument is set to true if the name is blank, and the last argument is part of the error message written to the error file when verification fails.

### **RangeCheck**

The routine RangeCheck can be used to produce a reasonable error message to describe the situation in addition to setting the ErrorsFound

variable to true. Errors found can then be checked in the calling routine and the program terminated if desired.

```
SUBROUTINE RangeCheck(ErrorsFound,WhatFieldString,WhatObjectString,ErrorLevel, &
    LowerBoundString,LowerBoundCondition,UpperBoundString,UpperBoundCondition)
```

It can be used in a variety of places when the \minimum and \maximum fields will not work (e.g. different min/max dependent on some other field).

```
USE InputProcessor, ONLY: RangeCheck
---
ErrorsFound=.false.
CALL RangeCheck(ErrorsFound,'DryBulb Temperature','WeatherFile', &
    'SEVERE','> -70',(Drybulb>-70.), '< 70',(DryBulb <70.))
CALL RangeCheck(ErrorsFound,'DewPoint Temperature','WeatherFile', &
    'SEVERE','> -70',(Dewpoint>-70.), '< 70',(Dewpoint <70.))
CALL RangeCheck(ErrorsFound,'Relative Humidity','WeatherFile', &
    'SEVERE','> 0',(RelHum>=0.), '<= 110',(RelHum<=110.))
```

To examine one call:

The variable **DryBulb** is set to its value. In this case, it is coming from the **Weather File**. The **LowerBoundString** is '> - 70' and the **LowerBoundCondition** is (DryBulb>-70.) [this expression will yield true or false depending...]

The LowerBounds (**LowerBoundString**, **LowerBoundCondition**) are optional as are the UpperBounds (**UpperBoundString**, **UpperBoundCondition**). If we were only testing one set of ranges, the call would look like:

```
Call RangeCheck(ErrorsFound,'DryBulb Temperature','WeatherFile','SEVERE', &
    UpperBoundString='< 70', UpperBoundCondition=(DryBulb<70.))
```

ErrorLevel can be one of the usual Error levels:

**WARNING** – would be a simple warning message – the calling routine might reset the value to be within bounds

**SEVERE** – a severe error. Usually the program would terminate if this is in a “GetInput” routine. If during execution, the calling program could reset the value but RangeCheck contains too many string comparisons to be called for an execution problem.

**FATAL** – not likely to be used. You want to provide a context to the error and if really a fatal type error, you'd like to execute the RangeCheck call and then terminate from the calling program.

And the context for the message may be shown in the calling routine by checking the value of ErrorsFound:

```
ErrFound=.false.
Call RangeCheck(ErrFound,'This field','SEVERE','<= 100',(Value<100.))
IF (ErrFound) THEN
    CALL ShowContinueError('Occurs in routine xyz')
    ErrorsFound=.true. ! for later termination
ENDIF
```

### MakeUPPERCase

This function can be used to make sure an upper case string is being used. (Note this is not needed when using “SameString”). Parameter 1 to the function is the string to be upper cased:

```
USE InputProcessor, ONLY: MakeUPPERCase
---
```



```
UCString=MakeUPPERCase('lower string')
```

## Object Services

It is standard practice in EnergyPlus that only objects associated with a given module be accessed from the input data file using a GetObjectItem function call and that this type of function call only be executed during GetInput. For example, the module HVACDXSystem would only access the object DXSystem:AirLoop in the GetInput subroutine or the module HVACFanComponent would only access the different fan objects as shown in the example below. This programming standard requires that all modules be “responsible” for specific objects and no other module accesses the input data file for this specific object. Using this technique, maintenance of the EnergyPlus modules is limited to specific areas of software as input data for objects evolve for any reason.

*Module HVACDXSystem - SUBROUTINE GetDXCoolingSystemInput:*

```
CALL GetObjectItem('DXSYSTEM:AIRLOOP',DXCoolSysNum,AlphArray,
&
NumAlphas,NumArray,NumNums,IOSTAT)
```

*Module HVACFanComponent – SUBROUTINE GetFanInput:*

```
CALL
GetObjectItem('FAN:SIMPLE:CONSTVOLUME',SimpFanNum,AlphArray, &
NumAlphas,NumArray,NumNums,IOSTAT)
CALL GetObjectItem('FAN:SIMPLE:VARIABLEVOLUME',VarVolFanNum,
&
AlphArray,NumAlphas,NumArray,NumNums,IOSTAT)
CALL GetObjectItem('ZONE EXHAUST FAN',ExhFanNum,AlphArray, &
NumAlphas,NumArray,NumNums,IOSTAT)
CALL GetObjectItem('FAN:SIMPLE:ONOFF',OnOffFanNum,AlphArray, &
NumAlphas,NumArray,NumNums,IOSTAT)
```

If module developers were allowed to access the input data file for other objects not related to a particular module, both the original module and the alternate module would have to be corrected each time the object changed. This poses a severe hazard for future development of EnergyPlus.

Module developers may at times require information for specific objects from other modules. When this occurs, the information is “mined” through function or subroutine calls located in the other module. Existing function calls may be used or added to EnergyPlus as needed. In this way, a module developer could confirm that node information provided in a parent object matched the node information specified for its children object. Other error checking may also be performed in this manner. For example, if the module HVACDXSystem needed to know the capacity of the DX cooling coil, a function call to GetCoilCapacity in the DXCoil module would provide this information. The function GetCoilCapacity would “Get” the input from the input data file if it has not already been accessed and provide the information back to the calling module.

A variety of examples exist to aid the module developer in this area of programming.

- **DXCoil.f90:**

```
FUNCTION GetCoilCapacity(CoilType,CoilName,ErrorsFound) RESULT(CoilCapacity)
FUNCTION GetMinOATCompressor(CoilType,CoilName,ErrorsFound) RESULT(MinOAT)
FUNCTION GetCoilInletNode(CoilType,CoilName,ErrorsFound) RESULT(NodeNumber)
FUNCTION GetCoilOutletNode(CoilType,CoilName,ErrorsFound) RESULT(NodeNumber)
FUNCTION GetSupplyAirFanOperatingMode(CoilType,CoilName,ErrorsFound) RESULT(OpMode)
FUNCTION GetCoilCondenserNode(CoilType,CoilName,ErrorsFound) RESULT(CondNode)
FUNCTION GetHPCoolingCoilIndex(HeatingCoilType, HeatingCoilName, HeatingCoilIndex)
      RESULT(DXCoolingCoilIndex)
```

- **FanCoilUnits.f90:**

```
INTEGER FUNCTION GetFanCoilZoneInletAirNode(FanCoilNum)
INTEGER FUNCTION GetFanCoilOutAirNode(FanCoilNum)
INTEGER FUNCTION GetFanCoilReturnAirNode(FanCoilNum)
INTEGER FUNCTION GetFanCoilMixedAirNode(FanCoilNum)
```

- **HeatRecovery.f90:**

```
FUNCTION GetSupplyInletNode(HXName,ErrorsFound)
FUNCTION GetSupplyOutletNode(HXName,ErrorsFound)
FUNCTION GetSecondaryInletNode(HXName,ErrorsFound)
FUNCTION GetSecondaryOutletNode(HXName,ErrorsFound)
```

- **HVACFanComponent.f90:**

```
FUNCTION GetFanDesignVolumeFlowRate(FanType,FanName,ErrorsFound) RESULT(DesignVolumeFlowRate)
FUNCTION GetFanInletNode(FanType,FanName,ErrorsFound) RESULT(NodeNumber)
FUNCTION GetFanOutletNode(FanType,FanName,ErrorsFound) RESULT(NodeNumber)
SUBROUTINE GetFanVolFlow(FanIndex, FanVolFlow)
SUBROUTINE GetFanType(FanName,FanType,ErrorsFound,ThisObjectType)
```

- **HVACHeatingCoils.f90:**

```
FUNCTION GetCoilCapacity(CoilType,CoilName,ErrorsFound) RESULT(CoilCapacity)
FUNCTION GetCoilInletNode(CoilType,CoilName,ErrorsFound) RESULT(NodeNumber)
FUNCTION GetCoilOutletNode(CoilType,CoilName,ErrorsFound) RESULT(NodeNumber)
SUBROUTINE GetHeatingCoilIndex(HeatingCoilName,HeatingCoilIndex,ErrorsFound)
```

- **HVACHXAssistedCoolingCoil.f90:**

```
FUNCTION GetCoilCapacity(CoilType,CoilName,ErrorsFound) RESULT(CoilCapacity)
FUNCTION GetCoilInletNode(CoilType,CoilName,ErrorsFound) RESULT(NodeNumber)
FUNCTION GetCoilOutletNode(CoilType,CoilName,ErrorsFound) RESULT(NodeNumber)
FUNCTION GetHXDXCoilName(CoilType,CoilName,ErrorsFound) RESULT(DXCoilName)
FUNCTION GetCoilMaxWaterFlowRate(CoilType,CoilName,ErrorsFound) RESULT(MaxWaterFlowRate)
```

- **HVACStandAloneERV.f90**

```
FUNCTION GetSupplyAirFlowRate(ERVType,ERVCtrlName,ErrorsFound) RESULT(AirFlowRate)
FUNCTION GetSupplyAirInletNode(ERVType,ERVCtrlName,ErrorsFound) RESULT(AirInletNode)
FUNCTION GetExhaustAirInletNode(ERVType,ERVCtrlName,ErrorsFound) RESULT(AirInletNode)
INTEGER FUNCTION GetStandAloneERVOutAirNode(StandAloneERVNum)
INTEGER FUNCTION GetStandAloneERVZoneInletAirNode(StandAloneERVNum)
INTEGER FUNCTION GetStandAloneERVReturnAirNode(StandAloneERVNum)
```

- **HVACSteamCoilComponent.f90:**

```
FUNCTION GetCoilMaxWaterFlowRate(CoilType,CoilName,ErrorsFound) RESULT(MaxWaterFlowRate)
```

- **HVACWaterCoilComponent.f90:**

```
FUNCTION GetCoilMaxWaterFlowRate (CoilType,CoilName,ErrorsFound) RESULT (MaxWaterFlowRate)
FUNCTION GetCoilInletNode (CoilType,CoilName,ErrorsFound) RESULT (NodeNumber)
FUNCTION GetCoilOutletNode (CoilType,CoilName,ErrorsFound) RESULT (NodeNumber)
```

- **HVACWaterToAir.f90:**

```
FUNCTION GetCoilCapacity (CoilType,CoilName,ErrorsFound) RESULT (CoilCapacity)
FUNCTION GetCoilInletNode (CoilType,CoilName,ErrorsFound) RESULT (NodeNumber)
FUNCTION GetCoilCapacity (CoilType,CoilName,ErrorsFound) RESULT (CoilCapacity)
FUNCTION GetCoilInletNode (CoilType,CoilName,ErrorsFound) RESULT (NodeNumber)
```

- **MixedAir.f90:**

```
FUNCTION GetOAMixerNodeNumbers (OAMixerName,ErrorsFound) RESULT (OANodeNumbers)
FUNCTION GetNumOAMixers () RESULT (NumberOfOAMixers)
FUNCTION GetNumOAControllers () RESULT (NumberOfOAControllers)
FUNCTION GetOAMixerReliefNodeNumber (OAMixerNum) RESULT (ReliefNodeNumber)
FUNCTION GetOASystemNumber (OASysName) RESULT (OASysNumber)
FUNCTION GetOAMixerInletNodeNumber (OAMixerNumber) RESULT (OAMixerInletNodeNumber)
FUNCTION GetOAMixerReturnNodeNumber (OAMixerNumber) RESULT (OAMixerReturnNodeNumber)
FUNCTION GetOAMixerMixedNodeNumber (OAMixerNumber) RESULT (OAMixerMixedNodeNumber)
```

- **PackagedTerminalHeatPump.f90:**

```
INTEGER FUNCTION GetPTHPZoneInletAirNode (PTHPNum)
INTEGER FUNCTION GetPTHPOutAirNode (PTHPNum)
INTEGER FUNCTION GetPTHPReturnAirNode (PTHPNum)
INTEGER FUNCTION GetPTHPMixedAirNode (PTHPNum)
```

- **PurchasedAirManager.f90:**

```
FUNCTION GetPurchasedAirOutAirMassFlow (PurchAirNum) RESULT (OutAirMassFlow)
```

- **SetpointManager.f90:**

```
LOGICAL FUNCTION IsNodeOnSetPtManager (NodeNum,SetPtType)
```

- **UnitVentilator.f90:**

```
INTEGER FUNCTION GetUnitVentilatorOutAirNode (UnitVentNum)
INTEGER FUNCTION GetUnitVentilatorZoneInletAirNode (UnitVentNum)
INTEGER FUNCTION GetUnitVentilatorMixedAirNode (UnitVentNum)
INTEGER FUNCTION GetUnitVentilatorReturnAirNode (UnitVentNum)
```

- **WindowAC.f90:**

```
INTEGER FUNCTION GetWindowACZoneInletAirNode (WindACNum)
INTEGER FUNCTION GetWindowACOutAirNode (WindACNum)
INTEGER FUNCTION GetWindowACReturnAirNode (WindACNum)
INTEGER FUNCTION GetWindowACMixedAirNode (WindACNum)
```

These kinds of calls are highly encouraged so that data is mined from the other modules rather than being declared public.

The function call for GetCoilCapacity in module DXCoil.f90 is shown below. Note that the format for these function calls have the same format as other subroutines throughout the EnergyPlus software. The example function shown below is declared as a public routine in module DXCoils for use by other modules through a USE statement.

*Module DXCoils.f90:*

```
PUBLIC GetCoilCapacity
```

```

FUNCTION GetCoilCapacity(CoilType,CoilName,ErrorsFound)
RESULT(CoilCapacity)

    ! FUNCTION INFORMATION:
    !     AUTHOR      Linda Lawrie
    !     DATE WRITTEN February 2006
    !     MODIFIED    na
    !     RE-ENGINEERED na

    ! PURPOSE OF THIS FUNCTION:
    ! This function looks up the coil capacity for the given
    ! coil and returns it.  If incorrect coil type or name
    ! is given, errorsfound is returned as true and capacity
    ! is returned as negative.

    ! METHODOLOGY EMPLOYED:
    ! na

    ! REFERENCES:
    ! na

    ! USE STATEMENTS:
USE InputProcessor, ONLY: FindItemInList

IMPLICIT NONE ! Enforce explicit typing of all variables in
              ! this routine

    ! FUNCTION ARGUMENT DEFINITIONS:
CHARACTER(len=*), INTENT(IN) :: CoilType   ! must match coil
                                         ! types in this module
CHARACTER(len=*), INTENT(IN) :: CoilName   ! must match coil
                                         ! names for the coil type
LOGICAL, INTENT(INOUT)      :: ErrorsFound ! set to true if problem
REAL                        :: CoilCapacity ! returned capacity of
                                         ! matched coil

    ! FUNCTION PARAMETER DEFINITIONS:
    ! na

    ! INTERFACE BLOCK SPECIFICATIONS:
    ! na

    ! DERIVED TYPE DEFINITIONS:
    ! na

    ! FUNCTION LOCAL VARIABLE DECLARATIONS:
INTEGER :: WhichCoil

! Obtains and Allocates DXCoils
IF (GetCoilsInputFlag) THEN
    CALL GetDXCoils
    GetCoilsInputFlag = .FALSE.
END IF

IF (CoilType == 'COIL:DX:HEATINGEMPIRICAL' .or. &
    CoilType == 'COIL:DX:COOLINGBYPASSFACTOREMPIRICAL') THEN
    WhichCoil=FindItemInList(CoilName,DXCoil%Name,NumDXCoils)
    IF (WhichCoil /= 0) THEN
        CoilCapacity=DXCoil(WhichCoil)%RatedTotCap(1)
    ENDIF
ELSE
    WhichCoil=0
ENDIF
ENDIF

```

```

IF (WhichCoil == 0) THEN
  CALL ShowSevereError('Could not find CoilType=' &
    //TRIM(CoilType)//' with Name='//TRIM(CoilName)//'')
  ErrorsFound=.true.
  CoilCapacity=-1000.
ENDIF

RETURN

END FUNCTION GetCoilCapacity

```

Note that the function name in one module can be the same as a function name in a different module. In fact, for EnergyPlus this should be the case – the module should use a generic name that is typical of its function. The calling module should use a “local name” that better specifies the type of item it is accessing. For example, if module HVACFurnace required node or capacity information from identical functions contained in modules HVACHeatingCoils and DXCoils, these function names could easily be assigned more descriptive names in the HVACFurnace module as follows.

*Module HVACFurnace.f90:*

```

USE HeatingCoils, ONLY: GetHeatingCoilCapacity=>GetCoilCapacity,
  GetHeatingCoilInletNode=>GetCoilInletNode
USE DXCoils, ONLY: GetDXCoilCapacity=>GetCoilCapacity,
  GetDXCoilInletNode=>GetCoilInletNode

```

## Branch & Node Checking and Services

### BranchInputManager

For the most part, new modules do not use the BranchInputManager directly. Branches are “gotten” at a high management level. The main routines that might be used from the BranchInputManager are: NumBranchesInBranchList, GetBranchList and GetBranchData. The BranchInputManager also houses the Splitter and Mixer data: GetLoopSplitter and GetLoopMixer.

### NumBranchesInBranchList

This routine is used to get the number of branches in a branch list name (so that an appropriate array can be allocated).

```
INTEGER FUNCTION NumBranchesInBranchList(BranchListName)
```

An example of use:

```

=== Example ===
USE BranchInputManager, ONLY: NumBranchesInBranchList, . . .
. . .
PrimeAirSys(ASysNum)%NumBranches= &
  NumBranchesInBranchList(BranchListName)
IF (PrimeAirSys(ASysNum)%NumBranches.EQ.0) THEN
  CALL ShowSevereError('There must be at least 1 branch in system ' &
    //TRIM(PrimeAirSys(ASysNum)%Name))
  ErrorsFound=.true.
END IF
ALLOCATE (BranchNames(PrimeAirSys(ASysNum)%NumBranches))
BranchNames=' '

```

### GetBranchList

This routine is used to get the names of the branches on a Loop.

```

SUBROUTINE GetBranchList (LoopName, BranchListName, NumBranchNames,
BranchNames, LoopType)
=== Example ===
USE BranchInputManager, ONLY: GetBranchList, . . .
. . .

(NumBranches from NumBranchesInBranchList)
! get the branch lists
CALL GetBranchList (PrimeAirSys (ASysNum) %Name, BranchListName, &
    PrimeAirSys (ASysNum) %NumBranches, BranchNames, 'Air')
ALLOCATE (PrimeAirSys (ASysNum) %Branch (NumBranches))
. . . . .

```

The first argument is the loop name, the 2<sup>nd</sup> argument is the name of the Branch List, the 3<sup>rd</sup> argument is an output: the number of branch names, the 4<sup>th</sup> argument is an output: the names of the branches in the list, the 5<sup>th</sup> argument is the loop type.

### GetBranchData

This routine is used to get pieces of data about a branch.

```

SUBROUTINE GetBranchData (LoopName, BranchName, BranchMaxFlow, NumComps,
CompType, CompName, CompCtrlType, CompInletNodeNames, CompInletNodeNums,
CompOutletNodeNames, CompOutletNodeNums, ErrorsFound)
=== Example ===
! Cycle through all of the branches and set up the branch data
DO BNum = 1, PrimeAirSys (ASysNum) %NumBranches
    PrimeAirSys (ASysNum) %Branch (BNum) %Name = BranchNames (BNum)
    NumBComps = NumCompsInBranch (BranchNames (BNum))

    ALLOCATE (CompTypes (NumBComps))
    CompTypes = ' '
    ALLOCATE (CompNames (NumBComps))
    CompNames = ' '
    ALLOCATE (CompCtrls (NumBComps))
    CompCtrls = ' '
    ALLOCATE (InletNodeNames (NumBComps))
    InletNodeNames = ' '
    ALLOCATE (InletNodeNumbers (NumBComps))
    InletNodeNumbers = 0
    ALLOCATE (OutletNodeNames (NumBComps))
    OutletNodeNames = ' '
    ALLOCATE (OutletNodeNumbers (NumBComps))
    OutletNodeNumbers = 0

    CALL GetBranchData (PrimeAirSys (ASysNum) %Name, &
        BranchNames (BNum), &
        PrimeAirSys (ASysNum) %Branch (BNum) %MaxVolFlowRate, &
        NumBComps, &
        CompTypes, CompNames, CompCtrls, &
        InletNodeNames, InletNodeNumbers, &
        OutletNodeNames, OutletNodeNumbers, ErrorsFound)
    ALLOCATE &
    (PrimeAirSys (ASysNum) %Branch (BNum) %Comp (NumBComps))
    PrimeAirSys (ASysNum) %Branch (BNum) %TotalComponents = &
        NumBComps

    PrimeAirSys (ASysNum) %Branch (BNum) %TotalNodes = &
        NumBComps + 1

```

```

ALLOCATE (PrimeAirSys (ASysNum) %Branch (BNum) %NodeNum (NumBComps+1) )
PrimeAirSys (ASysNum) %Branch (BNum) %NodeNum (1) = &
    InletNodeNumbers (1)
PrimeAirSys (ASysNum) %Branch (BNum) %DuctType = Main
DO CNum = 1, PrimeAirSys (ASysNum) %Branch (BNum) %TotalComponents

    PrimeAirSys (ASysNum) %Branch (BNum) %Comp (CNum) %TypeOf = &
        CompTypes (CNum)
    PrimeAirSys (ASysNum) %Branch (BNum) %Comp (CNum) %Name = &
        = CompNames (CNum)
    PrimeAirSys (ASysNum) %Branch (BNum) %Comp (CNum) %Index = 0
    PrimeAirSys (ASysNum) %Branch (BNum) %Comp (CNum) %FlowCtrl= &
        CompCtrls (CNum)
    PrimeAirSys (ASysNum) %Branch (BNum) %Comp (CNum) %NodeNameIn=&
        InletNodeNames (CNum)
    PrimeAirSys (ASysNum) %Branch (BNum) %Comp (CNum) %NodeNumIn=&
        InletNodeNumbers (CNum)
    PrimeAirSys (ASysNum) %Branch (BNum) %Comp (CNum) %NodeNameOut=&
        OutletNodeNames (CNum)
    PrimeAirSys (ASysNum) %Branch (BNum) %Comp (CNum) %NodeNumOut= &
        OutletNodeNumbers (CNum)
    PrimeAirSys (ASysNum) %Branch (BNum) %NodeNum (CNum+1) = &
        OutletNodeNumbers (CNum)

```

### NodeInputManager

The NodeInputManager is responsible for getting all the node names and assigning each a number. Node names are learned in random order – which can make validation difficult. Internally nodes are referenced as number and should be integers in any data structure or reference. Two key routines are used for obtaining node numbers: GetOnlySingleNode and GetNodeNums.

### Node Information Arguments

Both routines need some extra information about the node as the number is obtained. This information is used to support fluid property calculations, the HVAC Diagram utility, and various diagnostic checks.

### NodeFluidType

This argument defines the type of fluid at this node such as air or water. The node fluid type is used for fluid property calculations and is reported in the list of nodes in the bnd output file. Parameter definitions for this argument can be found in DataLoopNode. As of version 1.3, the list of valid choices is:

```

! Valid Fluid Types for Nodes
INTEGER, PARAMETER :: NodeType_Unknown = 0 ! 'blank'
INTEGER, PARAMETER :: NodeType_Air     = 1 ! 'Air'
INTEGER, PARAMETER :: NodeType_Water   = 2 ! 'Water'
INTEGER, PARAMETER :: NodeType_Steam   = 3 ! 'Steam'
INTEGER, PARAMETER :: NodeType_Electric= 4 ! 'Electric'

CHARACTER(len=*), PARAMETER, DIMENSION(0:4) :: ValidNodeFluidTypes= &
    (/ 'blank'  ', ' &
    'Air'      ', ' &
    'Water'    ', ' &
    'Steam'    ', ' &
    'Electric' /)
INTEGER, PARAMETER :: NumValidNodeFluidTypes=4

```

Note that the argument passed in is an integer value – you can “USE DataLoopNode” and use the above definitions (preferred over either defining your own or passing in a number). In many cases, a component may not

know the fluid type. For example, most SET POINT MANAGERS are applicable to both air and water nodes. In this case, `NodeType_Unknown` should be used. It is assumed that for any given node, at least one object referencing it will know the fluid type. Once a known fluid type is passed for a given node, it cannot be changed. All references to the same node must specify the same fluid type or unknown. When all input has been gotten, all node fluid types should be known, but this is not being validated currently.

### **NodeObjectType**

This is the type of object which is referencing the node (e.g. Chiller:Electric). This information is used to generate the list of Parent and Non-Parent Node Connections in the bnd output file. This list is used by the HVAC Diagram utility.

### **NodeObjectName**

This is the name of the object which is referencing the node (e.g. My Chiller). This information is used to generate the list of Parent and Non-Parent Node Connections in the bnd output file. This list is used by the HVAC Diagram utility.

### **NodeConnectionType**

Parameter definitions for this argument can be found in `DataLoopNode`. As of version 1.2.0, the current list of choices is:

```
! Valid Connection Types for Nodes
CHARACTER(len=*), PARAMETER, DIMENSION(13) :: ValidConnectionTypes= &
    (/ 'Inlet      ', &
      'Outlet     ', &
      'Internal   ', &
      'ZoneNode   ', &
      'Sensor     ', &
      'Actuator   ', &
      'OutsideAir ', &
      'ReliefAir  ', &
      'ZoneInlet  ', &
      'ZoneReturn ', &
      'ZoneExhaust', &
      'Setpoint   ', &
      'Electric   ' /)
INTEGER, PARAMETER :: NumValidConnectionTypes=13

INTEGER, PARAMETER :: NodeConnectionType_Inlet = 1
INTEGER, PARAMETER :: NodeConnectionType_Outlet = 2
INTEGER, PARAMETER :: NodeConnectionType_Internal = 3
INTEGER, PARAMETER :: NodeConnectionType_ZoneNode = 4
INTEGER, PARAMETER :: NodeConnectionType_Sensor = 5
INTEGER, PARAMETER :: NodeConnectionType_Actuator = 6
INTEGER, PARAMETER :: NodeConnectionType_OutsideAir = 7
INTEGER, PARAMETER :: NodeConnectionType_ReliefAir = 8
INTEGER, PARAMETER :: NodeConnectionType_ZoneInlet = 9
INTEGER, PARAMETER :: NodeConnectionType_ZoneReturn = 10
INTEGER, PARAMETER :: NodeConnectionType_ZoneExhaust = 11
INTEGER, PARAMETER :: NodeConnectionType_Setpoint = 12
INTEGER, PARAMETER :: NodeConnectionType_Electric = 13
```

This information is used to generate the list of Parent and Non-Parent Node Connections in the bnd output file. This list is used by the HVAC Diagram utility.

After all input has been gotten, node connection types are also validated in `CheckNodeConnections` in `NodeInputManager` according to the following rules. The rules are intended to catch user input errors without placing



unnecessary constraints on system configurations. The validation checks are not exhaustive, so it is possible to pass all of the checks yet have a misconnected simulation. The main goal here is to prevent dangling nodes which do not behave as the user expects and can often go undetected without scrutinizing detailed outputs.

- For any node which is used as an actuator, the same node must also be used at least once as a node type which is not sensor or actuator or outsideair.
- For any node which is used as a setpoint, the same node must also be used at least once as a node type which is not a setpoint or outsideair.
- Every ZoneInlet must appear as an outlet from something, otherwise it will do nothing.
- Every ZoneExhaust must appear as an inlet to something, otherwise it will do nothing.
- Every inlet node should match either an Outlet, ZoneReturn, ZoneExhaust, ReliefAir, or OutsideAir node, with the following exceptions:
  - If an InletNode's object is AIR PRIMARY LOOP, CONDENSER LOOP, or PLANT LOOP, then skip the test.
  - If an InletNode's object is not one of the above types, it is valid if the same node name appears as an INLET to an AIR PRIMARY LOOP, CONDENSER LOOP, or PLANT LOOP.

If a node fails any of the above tests, a severe error message is generated. If a new module generates unexpected errors, check the node connection types used by a similar module. *If a given node is used in more than one way by an object, it may be necessary to register the node more than once by successive calls to GetOnlySingleNode or GetNodeNums with different arguments in each call.*

NodeConnectionType\_OutsideAir is intended to specify nodes which are connected to the outside air. For example, OUTSIDE AIR MIXER has an Outside\_Air\_Stream\_Node which is registered as NodeConnectionType\_Inlet, because it may have other components such as a preheat coil between it and the outside air. Whichever node ultimately connects to the outside air in this case will be registered as NodeConnectionType\_OutsideAir by an OUTSIDE AIR INLET NODE LIST object.

Some types of equipment take in outside air directly without relying on OUTSIDE AIR INLET NODE LIST to set the conditions on that node. For example, UNIT VENTILATOR and chillers with air cooled condensers do not require the use of an OUTSIDE AIR INLET NODE LIST. In these cases, the component registers the outside air node directly as NodeConnectionType\_OutsideAir. Given that the use of outside air nodes is not consistent throughout the code, it may be necessary at some point to relax or alter the validation rules associated with outside air nodes to accommodate a new type of module. Please consult with the team before changing these rules.

#### **NodeFluidStream**

This is an integer indicating which fluid stream this node belongs to (1, 2, 3). For components with a single fluid stream, such as a fan, set this to one for the inlet and outlet nodes. For components with multiple fluid streams, such as a water coil, matching inlets and outlets should use the same fluid stream

number. For example, the air inlet and air outlet would be stream 1, and the water inlet and water outlet would be stream 2. This information is used to generate the list of Parent and Non-Parent Node Connections in the bnd output file. This list is used by the HVAC Diagram utility.

### **ObjectIsParent**

True If the object is a parent object, false if not. Parameters are defined in DataLoopNode. As of version 1.2.0, the current list of choices is:

```
! Valid IsParent Types for Node Connections
LOGICAL, PARAMETER :: ObjectIsParent = .TRUE.
LOGICAL, PARAMETER :: ObjectIsNotParent = .FALSE.
```

What is a parent object? A parent object is one which encloses and references other objects. For example, FAN COIL UNIT:4 PIPE is a parent to a fan, a heating coil, a cooling coil, and an outside air mixer. In most cases, all nodes referenced by a parent object are duplicated in the non-parent objects which are the components which ultimately act on the fluid stream. From the perspective of the HVAC Diagram utility, every fluid loop must be a continuous connection of non-parent objects and zones. In this example, the nodes of the mixer, fan, coils, and zone form a complete loop. Some components, such as UNIT VENTILATOR are part parent and part non-parent. It is a parent to a fan, a heating coil, and a cooling coil, but it does not reference an explicit outside air mixer. The mixer is an implied component within the unit ventilator. In these cases, to facilitate drawing a loop in HVAC Diagram, it is necessary to create a non-parent component to carry the fluid. So, the unit ventilator uses the following approach as illustrated by the comments and source code. Note that Alphas(3), the air inlet node, is registered twice, once as an inlet to parent object UNIT VENTILATOR, and once as an inlet to the implicit non-parent object UNIT VENTILATOR-OA MIXER.

```
Excerpt from GetUnitVentilatorInput in UnitVentilator

! Main air nodes (except outside air node):
! For node connections, this object is both a parent and a non-parent, because the
! OA mixing box is not called out as a separate component, its nodes must be connected
! as ObjectIsNotParent. But for the fan and coils, the nodes are connected as
ObjectIsParent
! To support the diagramming tool, the unit ventilator inlet node must appear both as
! an inlet to the unit ventilator parent object and as an inlet to the implied
! non-parent OA mixing box within the unit ventilator.
! Because there is overlap between the nodes that are parent and non-parent, use a
different
! object type for the non parent nodes
UnitVent(UnitVentNum)%AirInNode = &
  GetOnlySingleNode(Alphas(3),ErrorsFound,'UNIT VENTILATOR',Alphas(1), &
    NodeType_Air,NodeConnectionType_Inlet,1,ObjectIsParent)
UnitVent(UnitVentNum)%AirInNode = &
  GetOnlySingleNode(Alphas(3),ErrorsFound,'UNIT VENTILATOR-OA MIXER',Alphas(1), &
    NodeType_Air,NodeConnectionType_Inlet,1,ObjectIsNotParent)

UnitVent(UnitVentNum)%AirOutNode = &
  GetOnlySingleNode(Alphas(4),ErrorsFound,'UNIT VENTILATOR',Alphas(1), &
    NodeType_Air,NodeConnectionType_Outlet,1,ObjectIsParent)

UnitVent(UnitVentNum)%FanOutletNode = &
  GetOnlySingleNode(Alphas(5),ErrorsFound,'UNIT VENTILATOR',Alphas(1), &
    NodeType_Air,NodeConnectionType_Internal,1,ObjectIsParent)
```

### GetOnlySingleNode

This is used when only one node is expected as the input point. If this name points to a NodeList, an appropriate error message will be issued and errFlag (the second argument) will be set .true.

**GetOnlySingleNode** (NodeName, errFlag, NodeObjectType, NodeObjectName, NodeFluidType, NodeConnectionType, NodeFluidStream, ObjectIsParent)

It is used:

Example:

```
USE NodeInputManager, ONLY: GetOnlySingleNode
. . .
! get inlet node number
Baseboard(BaseboardNum)%WaterInletNode = &
    GetOnlySingleNode (AlphaArray(3), ErrorsFound, &
        'Baseboard Heater:Water:Convective', AlphaArray(1), &
        NodeType_Water, NodeConnectionType_Inlet, &
        1, ObjectIsNotParent)
! get outlet node number
Baseboard(BaseboardNum)%WaterOutletNode = &
    GetOnlySingleNode (AlphaArray(4), ErrorsFound, &
        'Baseboard Heater:Water:Convective', AlphaArray(1), &
        NodeType_Water, NodeConnectionType_Outlet, &
        1, ObjectIsNotParent)
```

The first argument is the node name, the 2<sup>nd</sup> argument is the error flag variable, the 3<sup>rd</sup> argument is the object type, the 4<sup>th</sup> argument is the object name – the remainder arguments are as listed above.

### GetNodeNums

This is used when more than one node is valid for an input. Like the GetOnlySingleNode invocation, GetNodeNums needs the extra information for a node:

```
SUBROUTINE GetNodeNums (Name, NumNodes, NodeNumbers, ErrorsFound, &
    NodeFluidType, NodeObjectType, NodeObjectName, &
    NodeConnectionType, NodeFluidStream, ObjectIsParent)

Example:
USE NodeInputManager, ONLY: GetNodeNums
. . .
CHARACTER(len=MaxNameLength), DIMENSION(4) :: AlphaArray
INTEGER :: NumNodes
INTEGER, DIMENSION(25) :: NodeNums
. . .
! Get the supply nodes
ErrInList=.false.
CALL GetNodeNums (Names(8), NumNodes, NodeNums, ErrInList, NodeType_Air, &
    'AIR PRIMARY LOOP', PrimaryAirSystem(AirSysNum)%Name, &
    NodeConnectionType_Inlet, 1, ObjectIsParent)
IF (ErrInList) THEN
    CALL ShowContinueError('Invalid Node Name or Node List in Air System=' &
        //TRIM(PrimaryAirSystem(AirSysNum)%Name))
    ErrorsFound=.true.
ENDIF
! Allow at most 3 supply nodes (for a 3 deck system)
IF (NumNodes > 3) THEN
    CALL ShowSevereError('Air System:Only 1st 3 Nodes will be used from:' &
        //TRIM(Names(8)))
    CALL ShowContinueError('Occurs in Air System='// &
        TRIM(PrimaryAirSystem(AirSysNum)%Name))
    ErrorsFound=.true.
ENDIF
```

```

IF (NumNodes.EQ.0) THEN
  CALL ShowSevereError('Air System:there must be at least 1 '// &
    'supply node in system '//TRIM(Names(1)))
  CALL ShowContinueError('Occurs in Air System='// &
    TRIM(PrimaryAirSystem(AirSysNum) %Name))
  ErrorsFound=.true.
END IF
. . . . .

```

The first argument is a node name or the name of a Node List, the 2<sup>nd</sup> argument is the number of nodes in the Node List (1 for a single node), the 3<sup>rd</sup> argument is the output: a list of node numbers – these are followed by the arguments shown above.

### Unique Node Checking

A set of routines will allow you to use the NodeInputManager to check for unique node names across a set of inputs. This is used currently in the CONTROLLED ZONE EQUIP CONFIGURATION object where each zone node mentioned must be unique. Three routines comprise the unique node check: InitUniqueNodeCheck, CheckUniqueNodes, EndUniqueNodeCheck

#### InitUniqueNodeCheck

A call to this routine starts the collection and detection of unique/non-unique nodes by the NodeInputManager:

```

USE NodeInputManager, ONLY: InitUniqueNodeCheck, CheckUniqueNodes, &
  EndUniqueNodeCheck
. . .
CALL InitUniqueNodeCheck ('CONTROLLED ZONE EQUIP CONFIGURATION')

```

The only argument is a simple string that will help with error messages that may come from the NodeInputManager. Unique node checking can only be done for one context ('CONTROLLED ZONE EQUIP CONFIGURATION') at a time.

#### CheckUniqueNodes

```

SUBROUTINE CheckUniqueNodes (NodeTypes, CheckType, ErrorsFound, &
  CheckName, CheckNumber)

```

This is the routine called during the getting of the nodes. The CheckType argument can be 'Nodename' or 'NodeNumber' and then pass in the appropriate argument to CheckName or CheckNumber. CheckName and CheckNumber are optional arguments – only the necessary one need be supplied.

Argument 1, NodeTypes, is the type of node being looked for – this argument is used for error messages within the NodeInput processing. Argument 2, ErrorsFound, will be set to true if this node is not unique in the current context.

```

Example:
  UniqueNodeError=.false.
  CALL CheckUniqueNodes ('Zone Air Node', 'NodeName', UniqueNodeError, &
    CheckName=AlphaArray(5))
  IF (UniqueNodeError) THEN
    CALL ShowContinueError('Occurs for Zone='//TRIM(AlphaArray(1)))
    ErrorsFound=.true.
  ENDIF

```

### **EndUniqueNodeCheck**

This routine terminates the unique node check – allows arrays to be deallocated, etc.

CALL **EndUniqueNodeCheck** ('CONTROLLED\_ZONE\_EQUIP\_CONFIGURATION')

The only argument is the Context String – which must match the string given in the InitUniqueNodeCheck routine.

### **SetUpCompSets and TestCompSet**

SetUpCompSets and TestCompSet are used to develop a list of hierarchical relationships between HVAC objects. The CompSet routines are housed in the BranchInputManager. A list of component sets is built which contains the following information:

Parent Object Type (Currently cannot be SPLITTER or MIXER)

Parent Object Name

Child Component Type (Currently cannot be SPLITTER or MIXER)

Child Component Name

Child Component InletNodeName

Child Component OutletNodeName

Node Description

Parent and child refer to a hierarchical relationship of two HVAC objects. For example, a branch is the parent to a pump, and a fan coil is the parent to a fan. The component sets do not include peer-to-peer connections such as a splitter connected to a branch, or a zone supply air path connected to an air loop.

The following rules apply to component sets:

- Each parent/child component set is unique. The same pair of components should never appear in the component sets list more than once.
- Each set of child component plus inlet and outlet nodes is unique.
- Each child component must have a parent component.
- A given component may appear in multiple component sets as a parent component.
- A given component may appear in multiple component sets as a child component only if there is a different set of inlet/outlet nodes. *(This was originally the intent, but some new components do not fit this rule well and it may need to be relaxed.)*
- If a given node name appears more than once as an inlet node, the two components which use it must share a parent/child relationship.
- If a given node name appears more than once as an outlet node, the two components which use it must share a parent/child relationship.
- After the program has read all the input data, there should be no "UNDEFINED" values in the list of component sets.

When any of these rules are violated, a warning is issued indicating a possible node connection error.

```

** Warning ** Potential Node Connection Error for object PIPE,
name=CW_BYPASS
**   ~~~   **   Node Types are still UNDEFINED -- See Branch/Node
Details file for further information
**   ~~~   **   Inlet Node : CW_BYPASS_INLET
**   ~~~   **   Outlet Node: CW_BYPASS_OUTLET

```

The component sets are reported in the eplusout.bnd file:

```

! <Component Set>,<Component Set Count>,<Parent Object Type>,<Parent
Object Name>,<Component Type>,<Component Name>,<Inlet Node ID>,<Outlet
Node ID>,<Description>

```

```

Component Set,1,BRANCH,COOLING SUPPLY INLET BRANCH,PUMP:VARIABLE
SPEED,CHW CIRC PUMP,CHW SUPPLY INLET NODE,CHW PUMP OUTLET NODE,Water
Nodes

```

```

Component Set,21,FAN COIL UNIT:4
PIPE,ZONE1FANCOIL,FAN:SIMPLE:CONSTVOLUME,ZONE1FANCOILFAN,ZONE1FANCOILOAMI
XEROUTLETNODE,ZONE1FANCOILFANOUTLETNODE,Air Nodes

```

### SetUpCompSets

SetUpCompSets should be called any time a parent object such as a branch or a compound object (e.g. furnace) references a child component which is connected to it. If an object has more than one child component, then SetUpCompSets is called once for each child.

SetUpCompSets first looks for the child component in the existing list of component sets by looking for a matching component type and name. If it is found, then the parent name and type are filled in. If the child component is not found in the existing list, then a new component set is created.

```

SUBROUTINE
SetUpCompSets (ParentType, ParentName, CompType, CompName, InletNode, Outlet
Node, Description)

```

The arguments are:

ParentType	Parent Object Type
ParentName	Parent Object Name
CompType	Child Component Type
CompName	Child Component Name
InletNode	Child Component Inlet Node Name
OutletNode	Child Component Outlet Node Name
Description	Description of nodes (optional)

For example, AirLoopHVAC:Unitary:Furnace:HeatOnly references a fan and a heating coil:

```

AirLoopHVAC:Unitary:Furnace:HeatOnly,
    \memo identical to the AirLoopHVAC:UnitaryHeatOnly object
    \min-fields 14
A1, \field Name
    \required-field
    \type alpha
A2, \field Availability Schedule Name

```

```

        \required-field
        \type object-list
        \object-list ScheduleNames
A3, \field Furnace Air Inlet Node Name
        \required-field
        \type alpha
A4, \field Furnace Air Outlet Node Name
        \required-field
        \type alpha
A5, \field Supply Air Fan Operating Mode Schedule Name
        \type object-list
        \object-list ScheduleNames
        \note A fan operating mode schedule value of 0 indicates
cycling fan mode (supply air
        \note fan cycles on and off in tandem with the heating coil).
        \note Any other schedule value indicates continuous fan mode
(supply air fan operates
        \note continuously regardless of heating coil operation).
        \note Leaving this schedule name blank will default to cycling
fan mode for the
        \note entire simulation period.
N1, \field Maximum Supply Air Temperature
        \type real
        \units C
        \autosizable
        \default 80.0
N2, \field Supply Air Flow Rate
        \required-field
        \type real
        \note This value should be > 0 and <= than the fan air flow
rate.
        \units m3/s
        \minimum> 0.0
        \autosizable
A6, \field Controlling Zone or Thermostat Location
        \required-field
        \type object-list
        \object-list ZoneNames
N3, \field Fraction of Supply Air Flow That Goes Through the
Controlling Zone
        \required-field
        \type real
        \minimum> 0.0
        \maximum 1.0
        \autosizable
A7, \field Supply Fan Object Type
        \required-field
        \type choice
        \key Fan:OnOff
        \key Fan:ConstantVolume
        \note Fan:ConstantVolume only works with continuous fan
operating mode (i.e. fan
        \note operating mode schedule values are greater than 0).
A8, \field Supply Fan Name
        \required-field
        \type object-list
        \object-list FansCVandOnOff
A9, \field Fan Placement
        \type choice
        \key BlowThrough
        \key DrawThrough
        \default BlowThrough
A10, \field Heating Coil Object Type

```

```

    \required-field
    \type choice
    \key Coil:Heating:Gas
    \key Coil:Heating:Electric
    \note Only works with gas and electric coils
All; \field Heating Coil Name
    \required-field
    \type object-list
    \object-list HeatingCoilsGasElec

```

In this case, the furnace is the parent object to the fan and the heating coil. To set up the component set for the furnace and its fan, the furnace type and name, the fan type and name (A7 and A8), and the furnace/fan inlet and fan outlet nodes (A3 and A9) are passed to `SetUpCompSets`:

Example:

```

USE BranchInputManager, ONLY: SetUpCompSets
. . .
CALL SetUpCompSets (
Furnace (FurnaceNum) %FurnaceType, Furnace (FurnaceNum) %Name,
AlphaArray (7), AlphaArray (8), AlphaArray (3), AlphaArray (9) )

```

In some cases, the inlet or outlet node names may not be known by the parent object. In this case, "UNDEFINED" is passed to `SetUpCompSets`.

Examples:

```

USE BranchInputManager, ONLY: SetUpCompSets
. . .
CALL SetUpCompSets (
Furnace (FurnaceNum) %FurnaceType, Furnace (FurnaceNum) %Name,
AlphaArray (8), AlphaArray (9), 'UNDEFINED', 'UNDEFINED' )

CALL SetUpCompSets (
Furnace (FurnaceNum) %FurnaceType, Furnace (FurnaceNum) %Name,
AlphaArray (12), AlphaArray (13), 'UNDEFINED', AlphaArray (4) )

```

### ***TestCompSet***

`TestCompSet` should be called by every HVAC object which has a parent object. A given object may be both a parent and a child. For example, **AirLoopHVAC:Unitary:Furnace:HeatOnly** is a child to a branch and a parent to a fan and coils.

`TestCompSet` first looks for the calling component in the existing list of component sets by looking for a matching component type and name. If the found compset has inlet and outlet nodes defined, then these must also match. If a match is found, then any undefined node names are filled in and the description string for the nodes is added. If the component is not found, then a new component set is created with undefined parent object type and name.

```

SUBROUTINE
TestCompSet (CompType, CompName, InletNode, OutletNode, Description)

```



The arguments are:

CompType    Child Component Type  
 CompName    Child Component Name  
 InletNode    Child Component Inlet Node Name  
 OutletNode    Child Component Outlet Node Name  
 Description    Description of nodes

For example, **AirLoopHVAC:Unitary:Furnace:HeatOnly** is a child component with inlet and outlet nodes:

```
AirLoopHVAC:Unitary:Furnace:HeatOnly,
  \memo identical to the AirLoopHVAC:UnitaryHeatOnly object
  \min-fields 14
  A1, \field Name
     \required-field
     \type alpha
  A2, \field Availability Schedule Name
     \required-field
     \type object-list
     \object-list ScheduleNames
  A3, \field Furnace Air Inlet Node Name
     \required-field
     \type alpha
  A4, \field Furnace Air Outlet Node Name
     \required-field
     \type alpha
```

To register the component set for the furnace (as a child component), the furnace type and name, and the furnace inlet and outlet nodes (A3 and A4) along with a node descriptor are passed to TestCompSets:

Example:

```
USE BranchInputManager, ONLY: TestCompSet

CALL TestCompSet (Furnace(FurnaceNum)%FurnaceType,AlphArray(1), &
                 AlphArray(3),AlphArray(4),'Air Nodes')
```

### CheckOutAirNodeNumber

Outside Air Nodes are special nodes connected to the outside environment. With the introduction of the Site Atmospheric Variation parameters, it becomes important to know whether the node name (e.g. Condenser Inlet Node on Air Cooled Chillers) is a legitimate outside air node or not. CheckOutAirNodeNumber allows you to determine if an entered node is, in fact, a proper outside air node.

Declaration:

```
FUNCTION CheckOutAirNodeNumber (NodeNumber) RESULT(Okay)
```

Example:

```
USE OutAirNodeManager, ONLY: CheckOutAirNodeNumber
DXCoil (DXCoilNum)%CondenserInletNodeNum(1) = &
  GetOnlySingleNode (Alphas(11),
                    ErrorsFound,ThisObjectType,DXCoil (DXCoilNum)%Name, &
                    NodeType_Air,NodeConnectionType_OutsideAirReference,1,
                    ObjectIsNotParent)
IF (.not. CheckOutAirNodeNumber (
    DXCoil (DXCoilNum)%CondenserInletNodeNum(1))) THEN
  CALL ShowSevereError (TRIM(ThisObjectType) //'',
```

```

        '//TRIM(DXCoil(DXCoilNum)%Name)//&
        '" Condenser Air Inlet Node Name not valid Outdoor Air Node = '//&
        TRIM(Alphas(11)))
    CALL ShowContinueError( &
'...does not appear in an OUTSIDE AIR INLET NODE LIST or as an OUTSIDE
AIR NODE.')
    ErrorsFound=.true.
END IF

```

Note that `GetOnlySingleNode` is used to get the proper node number, then the node number is used in the outside air node verification.

### CheckAndAddAirNodeNumber

Should you feel really nice about your users (or more likely be updating older code that may have allowed blanks in places that are properly outside air nodes), you can use the `CheckAndAddAirNodeNumber` routine to not only check to see if it is an outside air node but also add it at the same time.

```

Declaration:
SUBROUTINE CheckAndAddAirNodeNumber(NodeNumber,Okay)
USE OutAirNodeManager, ONLY: CheckAndAddAirNodeNumber
Example:
ElectricChiller(ChillerNum)%CondInletNodeNum = &
  GetOnlySingleNode(AlphArray(5),ErrorsFound, &
    'Chiller:Electric',AlphArray(1), NodeType_Air, &
    NodeConnectionType_OutsideAirReference, 2, ObjectIsNotParent)
CALL CheckAndAddAirNodeNumber( &
  ElectricChiller(ChillerNum)%CondInletNodeNum, &
  Okay)
IF (.not. Okay) THEN
  CALL ShowWarningError('Chiller:Electric, Adding Outside Air Node='// &
    AlphArray(5))
ENDIF

```

Note that here “not Okay” is not an error condition but rather the opportunity to notify the user that you are adding an air node.

## Schedule Services

Schedules are widely used in specifying input for building simulation programs. For instance heat gains from lighting, equipment and occupancy are usually specified using schedules. Schedules are used to indicate when equipment is on or off. Schedules are also used to specify zone and system set points. EnergyPlus uses schedules in all these ways and provides services that make using schedules very easy for the developer.

Schedules are specified in a three level hierarchy in EnergyPlus input.

**Day Schedules** (IDD Objects: Schedule:Day:Hourly, Schedule:Day:Interval, Schedule:Day:List)

**Week Schedules** (IDD Objects: Schedule:Week:Daily, Schedule:Week:Compact)

**Annual Schedules** (IDD Objects: Schedule:Year, Schedule:Compact, Schedule:File)

In addition, a **ScheduleTypeLimits** object can specify certain limits on the schedules. This is a mostly optional input but can be used effectively. (That is, if your examples include it, users will probably use it too.)

An example from an input (IDF) file:

```

ScheduleTypeLimits,
  Fraction,  !- ScheduleType Name
  0.0 : 1.0,  !- range
  CONTINUOUS;  !- Numeric Type

ScheduleTypeLimits,
  On/Off,  !- ScheduleType Name
  0:1,  !- range
  DISCRETE;  !- Numeric Type

! Schedule Constant
SCHEDULE:COMPACT,
Constant,
on/off,
Through: 12/31,
For: AllDays,
Until: 24:00, 1.0;

! Schedule Daytime Ventilation
SCHEDULE:COMPACT,
Daytime Ventilation,
Fraction,
Through: 12/31,
For: Weekdays SummerDesignDay,
Until: 08:00, 0.0,
Until: 18:00, 1.0,
Until: 24:00, 0.0,
For: Weekends WinterDesignDay,
Until: 10:00, 0.0,
Until: 16:00, 1.0,
Until: 24:00, 0.0,
For: Holidays AllOtherDays,
Until: 24:00, 0.0;

```

```

! Schedule Intermittent
SCHEDULE:COMPACT,
Intermittent,
Fraction,
Through: 12/31,
For: AllDays,
Until: 08:00, 0.0,
Until: 18:00, 1.0,
Until: 24:00, 0.0;

```

The day schedule elements assign numbers that span a full day (24 hours). The week schedule elements indicate which day schedules are applicable to each day of the week plus holiday and some special days. Schedule elements indicate which week schedules are applicable to various periods of the year. Both day schedules and schedules reference a schedule type. A schedule type is characterized by a range (e.g. 0 to 1) and whether it is continuous (can assume any value) or discrete (can assume integer values only). The following routines from the ScheduleManager module enable the developer to use schedules in a simulation.

### **GetScheduleIndex**

This function takes a schedule name as input and returns an internal pointer to the schedule. Schedule values will always be accessed via the pointer not the name during the simulation for reasons of efficiency. This function should be called once for each schedule during the input phase and the returned value stored in the appropriate data structure.

```

Example:
USE ScheduleManager, ONLY: GetScheduleIndex
. . .
Baseboard(BaseboardNum)%SchedPtr = GetScheduleIndex(AlphArray(2))

```

Here the schedule pointer for the schedule name contained in AlphArray(2) is stored in the baseboard data structure for later use. If a 0 is returned, this is not a valid schedule. Objects should also typically check for “blank” schedules.

### **GetDayScheduleIndex**

This function takes a “day schedule” name as input and returns an internal pointer to the schedule. Day schedule values will always be accessed via the pointer not the name during the simulation for reasons of efficiency. This function should be called once for each schedule during the input phase and the returned value stored in the appropriate data structure.

```

Example:
USE ScheduleManager, ONLY: GetDayScheduleIndex
. . .
DesDayInput(EnvrnNum)%RelHumSchPtr=GetDayScheduleIndex(DDNames(4))

```

Here the day schedule pointer for the day schedule name contained in DDNames(4) is stored in the design day data structure for later use. If a 0 is returned, this is not a valid day schedule. Objects should also typically check for “blank” schedules.

### **CheckScheduleValueMinMax**

Since you can’t always rely on a user to input the ScheduleType, the ScheduleManager can be used to check the minimum and/or maximum values for a schedule.

```

LOGICAL FUNCTION CheckScheduleValueMinMax(ScheduleIndex, &
                                         MinString,Minimum,MaxString,Maximum)

```

The pair of specifications (MinString, Minimum) and (MaxString, Maximum) is optional -- only one set need be given.

Examples from the code:

```

USE ScheduleManager, ONLY: CheckScheduleValueMinMax
. . .
IF (.NOT. CheckScheduleValueMinMax(ScheduleIndex,'>=',0.,'<=',1.)) THEN
  CALL ShowSevereError('SET POINT MANAGER:SINGLE ZONE MIN HUM, humidity..')
  CALL ShowContinueError('Error found in schedule = '//TRIM(Alphas(3)))
  CALL ShowContinueError('set point values must be (>=0., <=1.)')
  ErrorsFound=.true.
END IF

```

### **CheckScheduleValue**

There are times when the “CheckScheduleValueMinMax” will not be sufficient to verify proper values. A good example is the “control type” schedules – valid values might be 0 through 4, but just checking the min/max will not tell you if it contains a specific value (say, 3). This function allows you to check the entire schedule for a specific value – this will be more useful for discrete schedules than for schedule types of a continuous nature but can be used for both.

```

LOGICAL FUNCTION CheckScheduleValue(ScheduleIndex,Value)

```

Example of use:

```
IF (CheckScheduleValue(CTIndex,REAL(SingleHeatingSetPoint))) THEN
```

Here, the CTIndex is a schedule index for the Control Type schedules.

SingleHeatingSetPoint is an integer value for that control type.

“CheckScheduleValue” is used to determine if the schedule does, in fact, contain that value.

### **GetScheduleMinValue**

There are times when you don’t necessarily want to issue an error message but might like to find out what the minimum value of a given schedule is. For example, if the schedule allowed for >1 multipliers on a given input.

```
FUNCTION GetScheduleMinValue(ScheduleIndex) RESULT(MinimumValue)
```

Example of use:

```
USE ScheduleManager, ONLY: GetScheduleMinValue
```

```
. . .
```

```
Value=GetScheduleMinValue(ScheduleIndex)
```

The only argument needed is the ScheduleIndex for the schedule. Note that all schedule values are stored as real numbers – if you have a discrete/integer valued schedule, you may wish to do some special checking of the min value.

### **GetScheduleMaxValue**

There are times when you don’t necessarily want to issue an error message but might like to find out what the maximum value of a given schedule is. For example, if the schedule allowed for >1 multipliers on a given input.

```
FUNCTION GetScheduleMaxValue(ScheduleIndex) RESULT(MaximumValue)
```

Example of use:

```
USE ScheduleManager, ONLY: GetScheduleMaxValue
```

```
. . .
```

```
Value=GetScheduleMaxValue(ScheduleIndex)
```

The only argument needed is the ScheduleIndex for the schedule. Note that all schedule values are stored as real numbers – if you have a discrete/integer valued schedule, you may wish to do some special checking of the min value.

### **GetCurrentScheduleValue**

This function returns the current schedule value for the current day and time, given the schedule pointer as input.

```
REAL FUNCTION GetCurrentScheduleValue(ScheduleIndex)
```

Example of use:

```
USE ScheduleManager, ONLY: GetCurrentScheduleValue
```

```
. . .
```

```
CloUnit = GetCurrentScheduleValue(People(PeopleNum)%ClothingPtr)
```

Notice that the developer doesn’t have to keep track of hour of the day, day of the month, or month. The program does all of that. The only input needed is the pointer to the schedule.

**GetScheduleValuesForDay**

This function returns the schedule values for a specific day, given the schedule index as input.

```
SUBROUTINE GetScheduleValuesForDay (ScheduleIndex, DayValues, JDay)
```

Example of use:

```
ALLOCATE (SVals1 (24, NumOfTimeStepInHour))
SVals1=0.0
...
DO JDay=1, 366
  CALL GetScheduleValuesForDay (CrossMixing (Loop) %SchedPtr, &
                                SVals1, JDay)
  IF (.not. ANY (SVals1 > 0.0)) CYCLE
...
END DO
```

**GetSingleDayScheduleValues**

This function returns the schedule values for a specific day schedule (used in Design Day input, for example).

```
SUBROUTINE GetSingleDayScheduleValues (DayScheduleIndex, DayValues)
```

Example of use:

```
ALLOCATE (DDRelHumValues (TotDesDays, 24, NumOfTimeStepInHour))
DDRelHumValues=0.0
...
CALL GetSingleDayScheduleValues (DesDayInput (EnvrnNum) %RelHumSchPtr, &
                                   DDRelHumValues (EnvrnNum, :, :))
```

**LookUpScheduleValue**

This function can be used to look up a schedule value for the current time or optionally for any specific hour, timestep, day of year.

```
REAL FUNCTION LookUpScheduleValue (ScheduleIndex, ThisHour,
                                   ThisTimeStep, ThisDayOfYear)
...
      ! FUNCTION ARGUMENT DEFINITIONS:
      INTEGER ScheduleIndex
      INTEGER, OPTIONAL :: ThisHour
      INTEGER, OPTIONAL :: ThisTimeStep
      INTEGER, OPTIONAL :: ThisDayOfYear
```

Example of use:

```
SchValue=LookUpScheduleValue (Surface (SNR) %SchedShadowSurfIndex, IHOURL, TS)
```

**Data Services**

For the most part, modules are independent and only need the data they have within or **USE** from other modules. Occasionally, this may take on more complicated needs such as accessing “real-time” values for meters and/or custom meters or current report variable names/values.. Meter names are standard; you may have to use user input to get custom meter names.

**Global variable: MetersHaveBeenInitialized**

Meters are a bit peculiar and aren’t fully set until the first run through the first time step of the HVAC simulation. Therefore, there is a global variable

“MetersHaveBeenInitialized” which is set to **true** after meters have been set up. If you have a call to your routine that must use meter values as part of the simulation, you must use this variable before your items can be set.

Example:

```
...
If (MetersHaveBeenInitialized) CALL ManageDemand
```

Only the first time step will be missed in your routine and that time step will be part of “warming up” the simulation, so there is minimal impact due to this limitation.

### **GetMeterIndex**

You use the GetMeterIndex to check if a meter is valid for a particular simulation or if the user has entered a custom meter of that name. You use the index returned in later calls to get the value of the meter. Returns 0 if there is no meter of that name.

Example:

```
INTEGER, EXTERNAL :: GetMeterIndex
...
thismeter=GetMeterIndex('Electricity:Facility')
```

### **GetVariableKeyCountAndType**

This subroutine returns the variable type (real, integer, meter, etc.) (varType) whether it is an averaged or summed variable (varAvgSum), whether it is a zone or HVAC time step (varStepType), and the number of keynames for a given report variable or report meter name (varName). The variable type (varType) and number of keys (numKeys) are used when calling subroutine GetVariableKeys to obtain a list of the keynames for a particular variable and a corresponding list of indexes. An INTERFACE statement exists in the module OPInterfaces.

Declaration:

```
SUBROUTINE GetVariableKeyCountandType(varName, numKeys, varType, &
                                     varAvgSum, varStepType, varUnits)
```

Example:

```
USE OPInterfaces, ONLY: GetVariableKeyCountandType
! call the key count function but only need count during this pass
CALL GetVariableKeyCountandType(AlphaArray(fldIndex), &
                               KeyCount, TypeVar, AvgSumVar, StepTypeVar, UnitsVar)
ALLOCATE (NamesOfKeys (KeyCount))
ALLOCATE (IndexesForKeyVar (KeyCount))
```

### **GetVariableKeys**

This subroutine returns a list of keynames and indexes associated with a particular report variable or report meter name (varName). This routine assumes that the variable type (real, integer, meter, etc.) may be determined by calling GetVariableKeyCountandType. The variable type and index can then be used with function GetInternalVariableValue to retrieve the current value of a particular variable/keyname combination. An INTERFACE statement exists in the module OPInterfaces.

Declaration:

```
SUBROUTINE GetVariableKeys (varName, varType, keyNames, keyVarIndexes)
```

Example:

```
USE OPInterfaces, ONLY: GetVariableKeys
CALL GetVariableKeys(AlphaArray(fldIndex), TypeVar, NamesOfKeys, &
```

```
IndexesForKeyVar)
```

! See earlier GetVariableKeyCountandType as well.

### **GetCurrentMeterValue**

You use the GetCurrentMeterValue to obtain the value of a meter at its last “reported value” (timestep). Note that all meters are reported on the zone time step. Returns 0.0 if the MeterNumber passed is <=0.

Example:

```
INTEGER, EXTERNAL :: GetCurrentMeterValue
```

```
...
```

```
thismetervalue=GetCurrentMeterValue(ElecFacilityMtrIndex)
```

### **GetInstantMeterValue**

You use the GetInstantMeterValue to get a component of a meter’s value by index type. The values returned are “raw” (that is, not weighted by time step values). In these calls, 1 is a zone time step index, 2 is a system time step index.

Example:

```
INTEGER, EXTERNAL :: GetInstantMeterValue
```

```
...
```

```
FuelType%ElecFacility = &
```

```
GetInstantMeterValue(FuelType%ElecFacilityIndex,1)*FracTimeStepZone + &
```

```
GetInstantMeterValue(FuelType%ElecFacilityIndex,2)
```

### **GetInternalVariableValue**

This function returns the current value of the Internal Variable assigned to the varType and keyVarIndex. Values may be accessed for real and integer report variables and meter variables. The variable type (varType) may be determined by calling subroutine and GetVariableKeyCountandType. The index (keyVarIndex) may be determined by calling subroutine GetVariableKeys. To use, there is an INTERFACE statement in DataGlobals.f90

Example:

```
USE DataGlobals, ONLY: GetInternalVariableValue
```

```
curValue = GetInternalVariableValue(curTypeOfVar,curVarNum)
```

## **Other Useful Utilities**

### **GetNewUnitNumber**

Rather than attempt to keep track of all open files and distribute this list to everyone, we have chosen to use a routine that does this operation. If you need to have a scratch file (perhaps when porting legacy code into EnergyPlus modules), you can use the GetNewUnitNumber function to determine a logical file number for the OPEN and READ/WRITE commands. The function works by looking at all open assigned files and returning a number that isn’t being used. This implies that you will OPEN the unit immediately after calling the function (and you should!).

Example:

```
INTEGER, EXTERNAL :: GetNewUnitNumber
```

```
...
```

```
myunit=GetNewUnitNumber()
```



```
OPEN (Unit=myunit,File='myscratch')
```

### FindUnitNumber

If you want to find out a unit number for a file you think is already open, you can use the FindUnitNumber function. For example, rather than creating a new unit for debug output, you could latch onto the same unit as currently used for the “eplusout.dbg” file.

```
Example:
INTEGER, EXTERNAL :: FindUnitNumber
...
myunit=FindUnitNumber('eplusout.dbg')
```

If that file is already opened, it will get back the unit number it is currently assigned to. If it is not opened or does not exist, it will go ahead, get a unit number, and OPEN the file. (Should not be used for Direct Access or Binary files!)

### FindNumberInList

Sometimes you would like to find a number in a list. This is applicable to integers only (e.g. Index numbers of some item).

```
Example:
INTEGER, EXTERNAL :: FindNumberInList
...
MatchingCooledZoneNum = &
  FindNumberInList(CtrlZoneNum, &
    AirToZoneNodeInfo(AirLoopNum)%CoolCtrlZoneNums, NumZonesCooled)
```

The location/index in the array **AirToZoneNodeInfo%CoolCtrlZoneNums** will be returned if it finds the number in the array. If 0 is returned, it did not find that number in the list.

### ValidateComponent

Many objects specify a component type as well as a component name. Or, an object might have only a component name. The ValidateComponent routine will allow for objects outside the scope of a current “GetInput” routine to verify that the specific component does exist in the input file.

```
SUBROUTINE ValidateComponent(CompType,CompName,IsNotOK,CallString)
```

CompType, CompName are the typical nomenclature for “Component Type” (e.g. Fan:Simple:OnOff) and “Component Name” (e.g. “my fan” – user specified). IsNotOk is a logical from the calling program that is set to true when the component is not on the input file. CallString should specify the calling object – so that an appropriate error message can be issued.

```
Example:
! No USE needed - straightforward routine in GeneralRoutines
CALL ValidateComponent(Furnace(FurnaceNum)%FanType, &
  Furnace(FurnaceNum)%FanName, IsNotOK, &
  'Furnace:BlowThru:HeatOnly')
IF (IsNotOK) THEN
  CALL ShowContinueError('In Furnace='// &
    TRIM(Furnace(FurnaceNum)%Name))
  ErrorsFound=.true.
ENDIF
```

Note that in the example, the FanType is entered by the user. This allows for ultimate flexibility though the example could also include appropriate fan

types that are inherent to the code (an acceptable, if somewhat inflexible, practice).

### CheckComponent

This routine is exactly like ValidateComponent but doesn't generate an error message. It could be used instead of ValidateComponent and you could use the "IsNoOK" to generate your own error message. However, the intended use is for checking out different components when you don't have the component type as a field for the object. Thus, you can easily check if there is an object (component type) with the name entered in your field.

```
SUBROUTINE CheckComponent (CompType, CompName, IsNotOK)
```

CompType, CompName are the typical nomenclature for "Component Type" (e.g. Fan:OnOff) and "Component Name" (e.g. "my fan" – user specified). IsNotOk is a logical from the calling program that is set to true when the component is not on the input file.

Example:

```
! No USE needed - straightforward routine in GeneralRoutines
CALL CheckComponent ('Furnace:BlowThru:HeatOnly', &
                    FurnaceRefName, IsNotOK)
IF (IsNotOK) THEN
  CALL CheckComponent ('Furnace:BlowThru:HeatCool', &
                      FurnaceRefName, IsNotOK)
  . . . more checks on IsNotOK
ELSE
  FurnaceType='Furnace:BlowThru:HeatOnly'
ENDIF
. . .
```

Note that in the example, the FurnaceRefName is entered by the user. And this module knows what kind of components it might be.

### CreateSysTimeIntervalString

A very important part of EnergyPlus simulation is to be able to alert the user to problems during the simulation. The CreateSysTimeIntervalString will help do that though a better use is the ShowContinueErrorTimeStamp routine. The routine has no argument – a string is returned. The example below also illustrates the preferred method of counting how many times an error is produced and not printing each occurrence.

Example:

```
USE General, ONLY: CreateSysTimeInterval
---
!The warning message will be suppressed during the warm up days.
If (.NOT.WarmUpFlag) Then
  ErrCount = ErrCount + 1
  IF (ErrCount < 15) THEN
    CALL ShowWarningError ('SimAirLoops: Max iterations exceeded for '// &
                          TRIM(PrimaryAirSystem(AirLoopNum)%Name)//', at '// &
                          TRIM(EnvironmentName)//', '//TRIM(CurMnDy)//' '// &
                          TRIM(CreateSysTimeIntervalString ()))
  ELSE
    IF (MOD(ErrCount,50) == 0) THEN
      WRITE(CharErrOut,*) ErrCount
      CharErrOut=ADJUSTL(CharErrOut)
      CALL ShowWarningError ('SimAirLoops: Exceeding max iterations'// &
                            ' continues...'//CharErrOut)
    ENDIF
  ENDIF
```

```
ENDIF
End If
```

### TrimSigDigits

Along with error messages to alert the user, oftentimes you'd like to include values that are in error. You can use what some of the examples have shown – Write(string,\*) value but that will produce many digits in real numbers. The TrimSigDigits routine will allow for easy modification to a set of digits. Note that there are two flavors (INTERFACE statement in module General) so that you can easily get the string value of an integer.

```
FUNCTION TrimSigDigits(RealValue,SigDigits) RESULT(OutputString)
```

And

```
FUNCTION TrimSigDigits(IntegerValue) RESULT(OutputString)
```

As seen in the following example of use in code, a real value is passed in as argument 1 and the number of digits desired is passed in as argument 2. Note that the routine will preserve any “E+xx” outputs when a value like .000000004 might be passed in.

```
USE General, ONLY: TrimSigDigits
. . .
CALL ShowWarningError('COIL:Water:DetailedFlatCooling in Coil = '// &
    TRIM(WaterCoil(coilNum)%Name))
CALL ShowContinueError('Air Flow Rate Velocity has greatly exceeded '// &
    'upper design guidelines of ~2.5 m/s')
CALL ShowContinueError('Air MassFlowRate[kg/s]='// &
    TRIM(TrimSigDigits(AirMassFlow,6)))

AirVelocity=AirMassFlow*AirDensity/WaterCoil(CoilNum)%MinAirFlowArea
CALL ShowContinueError('Air Face Velocity[m/s]='// &
    TRIM(TrimSigDigits(AirVelocity,6)))
CALL ShowContinueError('Approximate MassFlowRate limit for Face '// &
    Area[kg/s]='// &
    TRIM(TrimSigDigits(2.5*WaterCoil(CoilNum)%MinAirFlowArea/AirDensity,6)))
CALL ShowContinueError('COIL:Water:DetailedFlatCooling could be '// &
    'resized/autosized to handle capacity')
CoilWarningOnceFlag(CoilNum) = .False.
```

### RoundSigDigits

Similar to TrimSigDigits, the RoundSigDigits function may be used when you want to “round” the output string – perhaps for reporting and/or error messages. Note that there are two flavors (INTERFACE statement in module General) so that you can easily get the string value of an integer.

```
FUNCTION RoundSigDigits(RealValue,SigDigits) RESULT(OutputString)
```

And

```
FUNCTION RoundSigDigits(IntgerValue) RESULT(OutputString)
```

As seen in the following example of use in code, a real value is passed in as argument 1 and the number of digits desired is passed in as argument 2. Note that the routine will preserve any “E+xx” outputs when a value like .000000004 might be passed in.

```
USE General, ONLY: RoundSigDigits
. . .
LatOut=RoundSigDigits(Latitude,2)
LongOut=RoundSigDigits(Longitude,2)
TZOut=RoundSigDigits(TimeZoneNumber,2)
```

```

NumOut=RoundSigDigits (Elevation,2)
PressOut=RoundSigDigits (StdBaroPress,0)
Write (OutputFileInits,LocFormat) Trim(LocationTitle),TRIM(LatOut), &
                                     TRIM(LongOut), &
                                     TRIM(TZOut), &
                                     TRIM(NumOut), &
                                     TRIM(PressOut)

```

### SafeDivide

SafeDivide can be used when you might not be sure that the denominator in a divide will not be zero.

```

FUNCTION SafeDivide(a, b) RESULT (c)
USE General, ONLY: SafeDivide
. . .
Result=SafeDivide(A,B)

```

### SetupAndSort

SetupAndSort can be called to order/sort a character array. A companion index array goes along with it so that one does not have to supply an entire derived type to be sorted. This companion array is then used to point to the proper element of such structures.

```

SUBROUTINE SetupAndSort(CharacterList, iCharacterList)
USE SortAndStringUtilities, ONLY: SetupAndSort
. . .
A use:
ALLOCATE(iCharacterList(number of entries))
Do item=1,number of entries
  iCharacterList(item)=item
end do

! routine sorts this array and its companion
CALL SetUpAndSort(CharacterList,iCharacterList)

Do item=1,number of entries
  ! iCharacterList now points to actual structure
  Write(output,*) Structure(iCharacterList(item))%Name
enddo

```

## Error Messages

Three error message routines are provided for the developer, indicating three different levels of error severity: ShowFatalError, ShowSevereError, and ShowWarningError. Each takes a string as an argument. The string is printed out as the message body on the file "eplusout.err". There are two additional optional arguments, which are file unit numbers on which the message will also be printed. ShowFatalError causes the program to immediately abort.

Two other error messages can be used to help make the error file more readable: ShowContinueError and ShowContinueErrorTimeStamp. Finally, another similar ShowMessage call can be used to display an informative string to the error file (eplusout.err).

As indicated, all of the "show" error calls look the same:

```

SUBROUTINE <ErrorMessageCall>(ErrorMessage, OutUnit1, OutUnit2)

```

Or

```

SUBROUTINE ShowWarningError(ErrorMessage, OutUnit1, OutUnit2)

```

```

SUBROUTINE ShowSevereError (ErrorMessage, OutUnit1, OutUnit2)
SUBROUTINE ShowFatalError (ErrorMessage, OutUnit1, OutUnit2)
SUBROUTINE ShowContinueError (ErrorMessage, OutUnit1, OutUnit2)
SUBROUTINE ShowContinueErrorTimeStamp (ErrorMessage, OutUnit1, OutUnit2)
SUBROUTINE ShowMessage (Message, OutUnit1, OutUnit2)

```

Mostly, you would never use either of the optional “OutUnit” arguments. One use might be if you were, in addition to the normal EnergyPlus output files, writing your own output file that would be processed separately.

Format of the error messages should be such that it makes it easy for the developer or user to realize the context of the error. Obviously, it is usually easier for the developer as he/she can search the code for the error string, but hard for many users. Current suggested format is to include the Module Name and/or the Routine name. This is particularly useful when two or more places in the code have the same main error string but may mean different things: where one might be in a Plant Loop context and the other in a Condenser Loop context, for example.

Due to the optional parameters, Interface statements are set in DataGlobals and you must enter USE statements defining which of the error calls you wish to use.

Example:

```

USE DataGlobals, ONLY: ShowSevereError
.
.
.
IF (Construct(ConstrNum)%LayerPoint(Layer) == 0) THEN
  CALL ShowSevereError('Did not find matching material for construct ` &
    //TRIM(Construct(ConstrNum)%Name)// ` &
    `, missing material = ` &
    //TRIM(ConstructAlphas(Layer))`
  ErrorsFound=.true.
ENDIF

```

This code segment will produce (with proper conditions) the message onto the error file:

```

** Warning ** Did not find matching material for construct XYZ, missing
material = ABC

```

The ShowContinueError is used in conjunction with either ShowSevereError or ShowWarningError. The “~~~” characters represent the continuation:

```

** Warning ** The total number of floors, walls, roofs and internal mass
surfaces in Zone ZONE ONE
**   ~~~   ** is < 6. This may cause an inaccurate zone heat balance
calculation.
** Warning ** No floor exists in Zone=ZONE ONE
** Warning ** Surfaces in Zone="ZONE ONE" do not define an enclosure.
**   ~~~   ** Number of surfaces is <= 4 in this zone. View factor
reciprocity forced

```

The ShowContinueError is particularly useful with some of the previous routines that, in addition to signaling an error, produce their own error message. For example, see the example code in the ValidateComponent excerpt above. Note that no ShowContinueError should be used with the ShowFatalError as it immediately terminates the program. Instead, a Severe-Continue-Fatal sequence should be used.

Each GetInput routine is responsible for verifying its input. Rather than terminating with the first illegal value, however, it is better to have an “ErrorsFound” logical that gets set to true for error conditions during the main

routine processing and terminates at the end of the GetInput routine. Of course during simulation, conditions should also be checked and terminated if necessary. Try to give the user as much information as possible with the set of error routine calls.

Quite a complex message can be constructed using concatenation. These routines can also be used to output numeric fields by writing the numeric variables to a string variable, although this isn't very convenient.

A good use of the ContinueErrorTimeStamp as well as "counting" errors is shown below:

```

IF (OutDryBulbTemp .LT. 0.0) THEN
  CINErrCount1=CINErrCount1+1
  IF (CINErrCount1 < 15) THEN
    CALL ShowWarningError('ElectricChillerModel:Air Cooled '// &
      'Condenser Inlet Temperature below 0C')
    CALL ShowContinueErrorTimeStamp('OutDoor Dry Bulb='// &
      TRIM(RoundSigDigits(OutDryBulbTemp,2)('//',''))
  ELSE
    IF (MOD(CINErrCount1,50) == 0) THEN
      WRITE(CINCharErrOut,*) CINErrCount1
      CINCharErrOut=ADJUSTL(CINCharErrOut)
      CALL ShowWarningError('ElectricChillerModel:Air Cooled'// &
        'Condenser Inlet Temperature below 0C continues...' &
        //CINCharErrOut)
    ENDIF
  ENDIF
ENDIF

```

### Recurring Error Handling

One method of showing recurring errors is shown in the previous few paragraphs with the illustration of counting the number of times the error occurs, printing the first few times and then only printing every x times (e.g. 100) that it occurs after that.

In addition to that method, three routines will help you automate the task. These routines rely on the error message being displayed and can also keep track of values (min/max/sum) (and units thereof). And an error message index (pointer to the message in the recurring error structure) that is stored in your data structure is used.

<pre> SUBROUTINE ShowRecurringSevereErrorAtEnd(Message,MsgIndex,ReportMaxOf,ReportMinOf,ReportSumOf, &amp;       ReportMaxUnits,ReportMinUnits,ReportSumUnits) SUBROUTINE ShowRecurringWarningErrorAtEnd(Message,MsgIndex,ReportMaxOf,ReportMinOf,ReportSumOf, &amp;       ReportMaxUnits,ReportMinUnits,ReportSumUnits) SUBROUTINE ShowRecurringContinueErrorAtEnd(Message,MsgIndex,ReportMaxOf,ReportMinOf,ReportSumOf, &amp;       ReportMaxUnits,ReportMinUnits,ReportSumUnits) </pre>
--

The first two parameters (Message, MsgIndex) are required. The remaining six arguments (ReportMaxOf, ReportMinOf, ReportSumOf, ReportMaxUnits, ReportMinUnits, ReportSumUnits) are optional. To illustrate, we re-write the above call using the recurring error routines. (Note that we still do the first few counted because we are using the TimeStamp routine).

```

IF (OutDryBulbTemp .LT. 0.0) THEN
  CINErrCount1=CINErrCount1+1
  IF (CINErrCount1 < 15) THEN
    CALL ShowWarningError('ElectricChillerModel:Air Cooled '// &
      'Condenser Inlet Temperature below 0C')

```

```

        CALL ShowContinueErrorTimeStamp('OutDoor Dry Bulb='// &
            TRIM(RoundSigDigits(OutDryBulbTemp,2)//', '))
    ELSE
        CALL ShowRecurringWarningErrorAtEnd( &
            'ElectricChillerModel:Air Cooled'// &
            ' Condenser Inlet Temperature below 0C continues...',
            ElectricChiller(ChillerNum)%ErrCount1)
    ENDIF
ENDIF

```

Illustrations of use of these calls is seen in the PurchasedAir modules, DXCoil modules and others.

Another example is seen in the Dessiccant routines:

```

IF (Node(DesicDehum(DesicDehumNum)%RegenAirInNode)%MassFlowRate .NE. &
    RegenAirMassFlowRate) THEN
! Initialize standard air density
IF (MyOneTimeFlag) THEN
    RhoAirStdInit = PsyRhoAirFnPbTdbW(StdBaroPress,20.0,0.0)
ENDIF
CALL ShowRecurringSevereErrorAtEnd( &
    'Improper flow delivered by desiccant regen fan - RESULTS INVALID!
    Check regen fan capacity and schedule.', &
    DesicDehum(DesicDehumNum)%RegenFanErrorIndex1)
CALL ShowRecurringContinueErrorAtEnd( &
    TRIM(DesicDehum(DesicDehumNum)%DehumType)//'= ' // &
    TRIM(DesicDehum(DesicDehumNum)%Name), &
    DesicDehum(DesicDehumNum)%RegenFanErrorIndex2)
RhoAirStdInit = PsyRhoAirFnPbTdbW(StdBaroPress,20.0,0.0)
CALL ShowRecurringContinueErrorAtEnd( &
    TRIM('Flow requested [m3/s] from ' // &
    DesicDehum(DesicDehumNum)%RegenFanType)//'= ' // &
    TRIM(DesicDehum(DesicDehumNum)%RegenFanName), &
    DesicDehum(DesicDehumNum)%RegenFanErrorIndex3, &
    ReportMaxOf=(RegenAirMassFlowRate / RhoAirStdInit))
CALL ShowRecurringContinueErrorAtEnd( &
    'Flow request varied from delivered by [m3/s]', &
    DesicDehum(DesicDehumNum)%RegenFanErrorIndex4, &
    ReportMaxOf=((RegenAirMassFlowRate -
Node(DesicDehum(DesicDehumNum)%RegenAirInNode)%MassFlowRate) / RhoAirStdInit), &
    ReportMinOf=((RegenAirMassFlowRate -
Node(DesicDehum(DesicDehumNum)%RegenAirInNode)%MassFlowRate) / RhoAirStdInit))
ENDIF

```

## Display Strings

Two display routines are useful for displaying to the “run” log the progress of the simulation. Since EnergyPlus usually runs as a “console” mode application, users may monitor progress of the simulation. Thus, at times it is useful to have messages displayed there. These should be minimal in number though can be used effectively during debugging of new modules.

```

subroutine DisplayString(String)
subroutine DisplayNumberandString(Number,String)

```

The “String” parameters are normal strings. The “Number” parameter must be an integer.

## Performance Curve Services

Some HVAC equipment models in EnergyPlus use performance curves. These are polynomials in one or two independent variables that are used to

modify rated equipment performance for performance at the current, off-rated conditions. Most often the curves are functions of temperature – entering wetbulb and outside drybulb, for instance – or of the part load fraction. EnergyPlus provides services to input, store, and retrieve curve data and to evaluate curves given values of the independent variables. There are 3 curve objects: CURVE:QUADRATIC, CURVE:CUBIC, and CURVE:BIQUADRATIC.

### GetCurveIndex

This function takes a curve name as input and returns an internal pointer to the curve. Curve values will always be accessed via the pointer not the name during the simulation for reasons of efficiency. This function is usually called once for each curve during the input phase.

```
USE CurveManager, ONLY: GetCurveIndex
...
DXCoil (DXCoilNum)%CCapFTemp = GetCurveIndex (Alphas (5))
IF (DXCoil (DXCoilNum)%CCapFTemp .EQ. 0) THEN
  CALL ShowSevereError ('COIL:DX:BF-Empirical not found=' &
    //TRIM (Alphas (5)))
  ErrorsFound = .TRUE.
END IF
```

### GetCurveCheck

This function uses a curve name as well as an error indicator and object name to “get” a curve index and perform error checking in one call. The calling routine will need to check the value of the error flag and perform appropriate action.

```
FUNCTION GetCurveCheck (alph, errFlag, ObjName) &
  RESULT (GetCurveCheckOut)
```

The curve index (as in `GetCurveIndex`) is the result. Curve values will always be accessed via the pointer not the name during the simulation for reasons of efficiency. This function would be called during an input phase for an object.

```
USE CurveManager, ONLY: GetCurveCheck
...
GasAbsorber (AbsorberNum)%CoolCapFTCurve = &
  GetCurveCheck (AlphaArray (8), ErrorsFound, ChillerName)
GasAbsorber (AbsorberNum)%FuelCoolFTCurve = &
  GetCurveCheck (AlphaArray (9), ErrorsFound, ChillerName)
```

### GetCurveType

This function will tell the calling routine what the “curve type” that was input. This function may be useful if your module does different calculations depending on a curve type (i.e. cubic vs quadratic) or if it should not use a specific curve type. This function would be called during input phase for an object.

```
CHARACTER (len=20) FUNCTION GetCurveType (CurveIndex)
```

Example of use:

```
USE CurveManager, ONLY: GetCurveIndex, GetCurveType
...
SELECT CASE (GetCurveType (DXCoil (DXCoilNum)%CCapFTemp))
```



### CurveValue

This function takes the curves index and one or two independent variables as input and returns the curve value.

```
USE CurveManage, ONLY: CurveValue
. . .
! Get total capacity modifying factor (function of temperature)
! for off-rated conditions
50 TotCapTempModFac = CurveValue (DXCoil (DXCoilNum) %CCapFTemp,
                                InletAirWetbulbC, &
                                OutDryBulbTemp)
```

## Fluid Property Services

Fluid property routines have been implemented within EnergyPlus with the goal of making the specification of new fluids relatively easy for the user and (starting with version 1.2.1) not require the user to specify data for the most common loop fluids. Common refrigerants are listed within an extensive Reference Data Set (RDS) that is provided with the EnergyPlus program.

Fluids in EnergyPlus are broken into two categories: refrigerants and glycols. This relates back to the amount of information needed to determine the properties of the various fluid types inside the program. The decision to define or use one class of fluids or another relates back to whether or not one expects the fluid to change phase (liquid and/or vapor) or remain a liquid. When a developer feels that a fluid may change phase, all code should access the Refrigerant class of fluid property routines. When the developer is certain that the fluid will remain a liquid and wishes to abide by that assumption (generally, this is the case for most larger loops), all code from such modules should access the Glycol class of fluid property routines. Each of these classes will be described in separate sections below since each class has different subroutine access to the main module.

Internally, both the refrigerant and glycol classes of fluids use “table lookup” and interpolation to find the appropriate value of a fluid property. No curve fits are done internally and the interpolation search routines are currently not optimized (no interval halving or special fast searching techniques are used to find the values).

HOWEVER, if values out of range (too low or too high) are passed to the routines, the value returned is a valid value at the lowest or highest (respectively) input parameter (that was passed in out of range).

### Using Fluid Property Routines in EnergyPlus Modules

The routines are contained within a single module: **FluidProperties.f90**

Developers can use the routines anywhere inside EnergyPlus through the following USE statement:

#### USE FluidProperties

Access to this module may be limited by expanding this line of code with the ONLY designator.

### Fluid Properties Functions for Refrigerant Class Fluids

In EnergyPlus, a refrigerant fluid is capable of being either in the liquid or vapor phase. Due to this definition, data must be available for both of these regions in order for the program to accurately calculate the various fluid properties. There are eight possible functions that may be used to obtain refrigerant data using the Fluid Properties module. They include:

```

GetSatPressureRefrig (Refrigerant, Temperature, RefrigIndex, calledfrom)
GetSatTemperatureRefrig (Refrigerant, Pressure, RefrigIndex, calledfrom)
GetSatEnthalpyRefrig (Refrigerant, Temperature, Quality, RefrigIndex, calledfrom)
GetSatDensityRefrig (Refrigerant, Temperature, Quality, RefrigIndex, calledfrom)
GetSatSpecificHeatRefrig (Refrigerant, Temperature, Quality, RefrigIndex, calledfrom)
GetSupHeatEnthalpyRefrig (Refrigerant, Temperature, Pressure, RefrigIndex, calledfrom)
GetSupHeatPressureRefrig (Refrigerant, Temperature, Enthalpy, RefrigIndex, calledfrom)
GetSupHeatDensityRefrig (Refrigerant, Temperature, Pressure, RefrigIndex, calledfrom)

```

While most of the variables passed into the routine are self-explanatory, the three variables that are common to each of these functions are Refrigerant, RefrigIndex and calledfrom. **Refrigerant** in this case is the character string name of the refrigerant in question as listed in the input file using the FluidNames object. This must be passed into the function to identify the fluid being referenced. **RefrigIndex** is an internal variable. On the first call to the fluid property routine, it is zero. All of the fluid property routines are set-up to find a non-zero index in the local fluid property data structure that corresponds to this refrigerant name. Since finding the proper fluid from the fluid name each and every time is computationally slow, the index allows the code to quickly find the right data without doing an inordinate number of string comparisons. Thus, module developers should store the RefrigIndex in their own local data structure in addition to the refrigerant name. calledfrom is a string variable passed to the routine so that error messages coming from the above functions can give a better context for errors when they happen.

Units for these other variables in these function calls are: Joules per kilogram for enthalpy, degrees Celsius for temperature, Pascals for pressure, kilograms per cubic meter for density, and Joules per kilogram-degree Celsius for specific heat. Quality and concentration are dimensionless fractions. All variables are considered input variables.

Module developers should use the functions listed above to first determine whether they are in the saturated region or the superheated region. The GetSatPressureRefrig and GetSatTemperatureRefrig functions should assist the users in determining whether they are in or beyond the saturated region. Once this is determined, the developer can call the appropriate function to obtain the quantity of interest: in the saturated region this includes the enthalpy, density, or specific heat; in the superheated region this includes the enthalpy, pressure, or density.

### Reference Data Set (RDS) Values for Refrigerant Class Fluids

The data for refrigerants that are included in the reference data set that comes with EnergyPlus are as follows (temperatures in Celsius, pressure in MegaPascals):

Table 2. Regions for Fluid Properties

<b>Refrigerant</b>	<b>Sat. Temp range {C}</b>	<b>Super Temp range* {C}</b>	<b>Super Pressure range* {Pa}</b>
R11	-110 to 198	-110 to 255	6.8 to 1.6E6
R11(specheat)	-110 to 190		
R12	-157 to 112	-156 to 169	.3 to 1.6E7
R12(specheat)	-157 to 104		
R22	-157 to 96	-157 to 153	0.4 to 1.7E7
R22(specheat)	-157 to 88		
R123	-107 to 184	-106 to 240	4.9 to 1.5E7
R134a	-103 to 101	-103 to 158	400 to 1.6E7
R404a	-72 to 72	-72 to 72	2.3E4 to 3.7E6
R410a	-72 to 69	-72 to 69	3.1E4 to 4.7E6
R507a	-72 to 69	-72 to 69	2.5E4 to 3.6E6
NH3	-77 to 132	-77 to 189	6.3E3 to 2.2E7
NH3(specheat)	-73 to 124		
Steam	0 to 370	0 to 500	610 to 4.0E8
Steam(specheat)	0 to 370		

\*Obviously data for all temperatures at all pressures isn't loaded. The entire range of pressures given above will work, but the temperature range for a given pressure will be some subset of the Super Temp range shown above. Subcooled region actually only returns h(f) or the saturated liquid value at the temperature you input.

### **Fluid Property Data and Expanding the Refrigerants Available to EnergyPlus**

The Fluid Property routines have been reengineered to allow other users to add refrigerants to the input file without having to make any changes to the program code. The only requirement on input is that in order to add a new refrigerant, a user must enter a full set of data. The exact definition of a full set of data is given below.

As with all EnergyPlus input, the fluid properties data has both an input data description and a reference data set that must show up in the input file. All of the "standard" refrigerants listed above must show up in the in.idf file for it to be available to the rest of the simulation. Below is the description of the input data description syntax for the fluid properties entries.

The first syntax item lists all of the fluids present in an input file and categorizes them as either a refrigerant (such as R11, R12, etc.) or a glycol (such as ethylene glycol, propylene glycol, etc.). A refrigerant or glycol must be in this list in order to be used as a valid fluid in other loops in the input file.

```

FluidProperties:Names,
    \unique-object
    \extensible:2 repeat last two fields
    \memo list of potential fluid names/types in the input file, maximum of ten
A1, \field Fluid 1 Name
    \type alpha
A2, \field Fluid 1 Type
    \type choice
    \key Refrigerant
    \key Glycol
A3, \field Fluid 2 Name
    \type alpha
A4, \field Fluid 2 Type
    \type choice
    \key Refrigerant
    \key Glycol
A5, \field Fluid 3 Name
    \type alpha
A6, \field Fluid 3 Type
    \type choice
    \key Refrigerant
    \key Glycol

```

An example of this statement in an input data file is:

```

FluidProperties:Names,
R11, REFRIGERANT,
R12, REFRIGERANT,
R22, REFRIGERANT,
NH3, REFRIGERANT,
Steam, REFRIGERANT,
NewGlycol, GLYCOL,
SuperGlycol, GLYCOL;

```

All fluid properties vary with temperature. As a result, the following syntax allows the user to list the temperatures at which the data points are valid. Since in many cases, the temperatures will be similar, this provides a more compact input structure and avoids listing the temperatures multiple times. The name associated with the temperature list is the piece of information that will allow the actual fluid property data statements to refer back to or link to the temperatures. Up to 250 points may be entered with this syntax and temperatures must be entered in ascending order. Units for the temperatures are degrees Celsius. The same temperature list may be used by more than one refrigerant.

```

FluidProperties:Temperatures,
    \memo property values for fluid properties
    \memo list of up to 250 temperatures, note that number of property values must match the
number of properties
    \memo in other words, there must be a one-to-one correspondence between the property values
in this list and
    \memo the actual properties list in other syntax
    \memo degrees C (for all temperature inputs)
    \format FluidProperty
A1, \field Name
    \type alpha
N1, \field Temperature 1
    \type real
    \units C
< same thing repeated over and over again>
N250; \field Temperature 250
    \type real

```

An example of this statement in an input data file is:

```
FluidProperties:Temperatures,
  R11Temperatures,
  -70,-65,-60,-55,-50,-45,-40,-35,-30,-25,-20,-15,-10,-5,0,2,4,6,8,10,12,14,16,18,
  20,22,24,26,28,30,32,34,36,38,40,42,44,46,48,50,55,60,65,70,75,80,85,90,95,100,
  105,110,115,120,125,130,135,140,145,150,155,160,165,170,175,180,185,190,198;
```

Property data for the saturated region is entered with the following syntax. Before the actual data is entered, this line of input must identify the refrigerant the data is to be associated with, what the data represents (choice of one of three keywords), the phase of the data (either fluid or gas), and the temperature list reference that links each data point with a temperature.

```
FluidProperties:Saturated,
  \memo fluid properties for the saturated region
  \format FluidProperty
A1, \field Name
  \reference FluidNames
A2, \field Fluid Property Type
  \note Enthalpy Units are J/kg
  \note Density Units are kg/m3
  \note SpecificHeat Units are J/kg-K
  \note Pressure Units are Pa
  \type choice
  \key Enthalpy      ! Units are J/kg
  \key Density       ! Units are kg/m3
  \key SpecificHeat ! Units are J/kg-K
  \key Pressure      ! Units are Pa
A3, \field Fluid Phase
  \note Fluid=saturated fluid
  \note FluidGas=difference between saturated fluid and saturated vapor
  \type choice
  \key Fluid         ! saturated fluid
  \key FluidGas      ! saturated vapor
A4, \field Temperature Values Name
  \note Enter the name of a FluidProperties:Temperatures object.
  \reference FluidPropertyTemperatures
N1, \field Property Value 1
  \type real
N2, \field Property Value 2
  \type real
< same thing repeated over and over again>
N250; \field Property Value 250
  \type real
```

An example of this statement in an input data file is:

```
FluidProperties:Saturated,
  R11,ENTHALPY,FLUID,R11Temperatures, ! Enthalpy in J/kg
  153580,154600,156310,158580,161300,164380,167740,171330,175100,179020,183060,
  187190,191400,195680,200000,201740,203490,205240,207000,208770,210530,212310,
  214080,215870,217650,219860,221230,223030,224830,226630,228860,230250,232060,
  233860,235700,237520,239350,241180,243010,246350,249450,254080,258730,263480,
  268110,272860,277000,282410,287240,292120,297030,302000,307090,312080,317210,
  322400,327670,333020,338460,344010,349680,355500,361480,367690,374100,381060,
  388850,397280,426300;
```

The format of the data for the superheated region is almost identical to that of the saturated region with one addition—a pressure. The pressure is listed before the rest of the data and has units of Pa.



other than WATER as the fluid type in the appropriate input syntax. Data for various concentrations of these three default fluids encompasses the range over with these fluids and their combinations are in the liquid phase (-35 to 125 degrees Celsius). When the glycol combination in question is indeed a fluid, the functions will return the appropriate value for the parameter in question. If the glycol is either a solid or vapor, the routine will return a zero value. Units for the different properties are: Joules per kilogram-Kelvin for specific heat, Pascal-seconds for viscosity, Watts per meter-Kelvin for conductivity, and kilograms per cubic meter for density. In contrast to the refrigerant data which is included in the RDS and must be copied into the user input file if it is to be used, the glycol default data has been hardwired into EnergyPlus and does not need to be entered into the input file.

### Fluid Property Data and Expanding the Glycols Available to EnergyPlus

The format of the data for the glycols is almost identical to that of the superheated region for refrigerants with one exception—concentration replaces pressure. The concentration is listed before the rest of the data and is dimensionless.

```
FluidProperties:Concentration,
    \memo fluid properties for water/other fluid mixtures
    \format FluidProperty
A1, \field Fluid Name
    \reference FluidNames
    \note should not be any of the defaults (Water, EthyleneGlycol, or PropyleneGlycol)
A2, \field Fluid Property Type
    \note Density Units are kg/m3
    \note SpecificHeat Units are J/kg-K
    \note Conductivity Units are W/m-K
    \note Viscosity Units are N-s/m2
    \type choice
    \key Density      ! Units are kg/m3
    \key SpecificHeat ! Units are J/kg-K
    \key Conductivity ! Units are W/m-K
    \key Viscosity    ! Units are N-s/m2
A3, \field Temperature Values Name
    \note Enter the name of a FluidProperties:Temperatures object.
    \reference FluidPropertyTemperatures
N1, \field Concentration
    \note Glycol concentration for this list of properties entered as a fraction
    \type real
    \units dimensionless
    \minimum 0.0
    \maximum 1.0
N2, \field Property Value 1
    \type real
N3, \field Property Value 2
    \type real
< same thing repeated over and over again>
N250; \field Property Value 250
    \type real
```

An example of this statement in an input data file is:

```
FluidProperties:Concentration,
    MyPropyleneGlycol,SPECIFICHEAT ,GlycolTemperatures, ! Specific heat in J/kg-K
    0.8, ! Concentration
    2572,2600,2627,2655,2683,2710,2738,2766,2793,2821,2849,2876,2904,2931,2959,
    2987,3014,3042,3070,3097,3125,3153,3180,3208,3236,3263,3291,3319,3346,3374,
    3402,3429,3457;
```

The above input syntax is used to define data for a particular new fluid beyond the default glycol fluids. It would be repeated at other appropriate concentration values, if necessary, to define the fluid. It should be noted that

in order to enter a fluid, the user must specify all four of the properties: conductivity, specific heat, viscosity, and density.

In addition to specifying the raw data for a new glycol, the user must list the fluid in the FluidNames object and then specify the concentration in the GlycolConcentrations object as shown below:

```
FluidProperties:Names,
  MyPropyleneGlycol, GLYCOL;
GlycolConcentrations,
  MyPropyleneGlycol, GLYCOL;
```

The IDD description for the FluidProperties:GlycolConcentrations object is given below:

```
FluidProperties:GlycolConcentrations,
  \unique-object
  \memo list of glycols and what concentration they are, maximum of ten
  A1, \field Fluid 1 Name
      \type alpha
      \reference GlycolConcentrations
  A2, \field Glycol 1 Name
      \type choice
      \key EthyleneGlycol
      \key PropyleneGlycol
      \memo or UserDefined Fluid (must show up as a glycol in FluidProperties:Names list)
  N1, \field Glycol 1 Concentration
      \type real
      \minimum 0.0
      \maximum 1.0
  A3, \field Fluid 2 Name
      \type alpha
  A4, \field Glycol 2 Name
      \type choice
      \key EthyleneGlycol
      \key PropyleneGlycol
      \memo or UserDefined Fluid (must show up as a glycol in FluidProperties:Names list)
  N2, \field Glycol 2 Concentration
      \type real
      \minimum 0.0
      \maximum 1.0
  < . . . repeated up to 10 times . . . >
  A19, \field Fluid 10 Name
      \type alpha
  A20, \field Glycol 10 Name
      \type choice
      \key EthyleneGlycol
      \key PropyleneGlycol
      \memo or UserDefined Fluid (must show up as a glycol in FluidProperties:Names list)
  N10; \field Glycol 10 Concentration
      \type real
      \minimum 0.0
      \maximum 1.0
```

An example of how this would be used in an actual IDF is:

```
FluidProperties:GlycolConcentrations,
  MyProGly80Percent, !- fluid name 1
  MyPropyleneGlycol, !- glycol name 1
  0.8,
  EthGly30Percent, !- fluid name 2
  EthyleneGlycol, !- glycol name 2
  0.3; !- concentration 2
```

The key relationship in this syntax is how FluidNames relates to GlycolConcentrations and how to have modules access through the proper name. FluidNames are used to define raw data, whether for refrigerants or glycols. With a glycol, it is not enough to define raw data since this does not necessarily define the actual concentration of glycol being used. Thus, the



GlycolConcentrations object is needed. It defines a name for the actual glycol and then refers back to the FluidNames (first fluid listed in the above example) or to one of the default glycol fluids (second fluid listed in the above example). It is critical that module developers refer to the “fluid name” listed in the GlycolConcentrations object. This is the name used inside the fluid property module to access the proper data. Note that when the GlycolConcentrations object is read in during execution that the module will interpolate down from a two-dimensional array of data (variation on temperature and concentration) to a one-dimensional array of data (with temperature as the only independent variable, concentration of a glycol fluid on any loop is assumed to be constant). This means that only the temperature (along with the glycol fluid name and index) must be passed into the fluid property module and also saves execution time since only a one-dimensional interpolation is needed.

## Weather Services

All weather data (including SizingPeriod:DesignDay and Site:Location validation) are processed by the WeatherManager module. The SimulationManager invokes the WeatherManager at the proper times to retrieve data. The WeatherManager will retrieve the proper data for the current timestep/hour/day/month from the proper data source (design day definition, weather data file). The WeatherManager puts weather-type data (outside dry bulb, outside wet bulb, humidity, barometric pressure) into the DataEnvironment global data area. There is no need for other modules to call the WeatherManager directly. However, if there is some weather-type data that is needed and not provided in the DataEnvironment global area, contact us.

## Global Data: Flags and Parameters

Global data is used sparsely in EnergyPlus, according to our goals and programming standards. Data-only modules should be used to share data, usually across a limited number of other modules. Two critical data-only modules have been used:

**DataGlobals** – contains truly global data (such as number of zones, current hour, simulation status flags, interface statements to error and output routines)

**DataEnvironment** – contains weather data that is global (such as current outdoor dry-bulb temperature, barometric pressure, etc.)

As an example of a limited data-only module, **DataSurfaces** contains data that is used in the modules that reference surfaces e.g., shadowing calculations, heat balance calculations.

Module excerpts in this document show uses of these data-only modules.

### Parameters

Constants that might be useful throughout the program are defined as Fortran parameters in the DataGlobals data module. Examples include *PI*, *PiOvr2*, *DegToRadians*, and *MaxNameLength*. DataHVACGlobals contains

parameters that might be useful anywhere in the HVAC simulation. Some examples are *SmallTempDiff* and *SmallMassFlow* that can be used for preventing divide by zero errors. The full set of global parameters can be obtained by examining the modules *DataGlobals* and *DataHVACGlobals*.

### **Simulation Flags**

A number of logical flags (variables that are either *true* or *false*) are used throughout EnergyPlus. These flags are normally used to indicate the start or end of a time or simulation period. The following shows a complete list.

#### **In DataGlobals:**

##### **BeginSimFlag**

Set to true until the actual simulation has begun, set to false after first heat balance time step.

##### **BeginFullSimFlag**

Set to true until a full simulation begins (as opposed to a sizing simulation); set to false after the first heat balance time step of the full simulation.

##### **EndSimFlag**

Normally false, but set to true at the end of the simulation (last heat balance time step of last hour of last day of last environment).

##### **WarmupFlag**

Set to true during the warmup portion of a simulation; otherwise false.

##### **BeginEnvrnFlag**

Set to true at the start of each environment (design day or run period), set to false after first heat balance time step in environment. This flag should be used for beginning of environment initializations in most HVAC components. See the example module for correct usage.

##### **EndEnvrnFlag**

Normally false, but set to true at the end of each environment (last heat balance time step of last hour of last day of environment).

##### **BeginDayFlag**

Set to true at the start of each day, set to false after first heat balance time step in day.

##### **EndDayFlag**

Normally false, but set to true at the end of each day (last heat balance time step of last hour of day).

##### **BeginHourFlag**

Set to true at the start of each hour, set to false after first heat balance time step in hour.

##### **EndHourFlag**

Normally false, but set to true at the end of each hour (last heat balance time step of hour)

**BeginTimeStepFlag**

Set to true at the start of each heat balance time step, set to false after first HVAC step in the heat balance time step.

**In DataHVACGlobals:****FirstTimeStepSysFlag**

Set to true at the start of the first HVAC time step within each heat balance time step, false at the end of the HVAC time step. In other words, this flag is true during the first HVAC time step in a heat balance time step, and is false otherwise.

**In Subroutine SimHVAC:****FirstHVACIteration**

True when HVAC solution technique on first iteration, false otherwise. Passed as a subroutine argument into the HVAC equipment simulation driver routines.

The most commonly used logical flag in the HVAC simulation is FirstHVACIteration that is passed around as an argument among the HVAC simulation subroutines. The HVAC simulation is solved iteratively each HVAC time step. FirstHVACIteration is true for the first iteration in each time step and false for the remaining iterations.

Finally, each developer must define and set a "GetInput" flag to make sure input data is read in only once. In the example module Fans the GetInput flag is GetInputFlag; the new developer can follow this example in using such a flag.

**Psychrometric services**

EnergyPlus has a full complement of psychrometric functions. All the routines are Fortran functions returning a single precision real value. All arguments and results are in SI units.

Note that each of the psychrometric routines has a "calledfrom" optional parameter – this has been implemented in some of the calling routines and is useful when errors are detected during simulation for support personnel to figure out where the psych routine is called from.

The Names for the different Psychrometric Routines are based on the following self-explanatory format; the different variables used in the Psych Routine taxonomy are as follows.

- H = Enthalpy
- W= Humidity Ratio
- Rh= Relative Humidity
- V= Specific Volume
- Rhov= Vapor Density of Air
- Hfg = Latent energy (heat of vaporization for moist air)
- Hg= Enthalpy of gaseous moisture
- Pb= Barometric Pressure
- Twb=Temperature Wet Bulb
- Twd= Temperature Dry Bulb
- Tdp= Temperature Dew Point

- Tsat and Psat= Saturation Temperature and Saturation Pressure
- $\text{Psy}_{\#\# \text{Fn} \#\#} = \text{Psy} \{\#\# \text{ is a Function of } \#\#\}$
- Note: Each of the two capital alphabets together have different meaning  
Eg:  $\{\text{Psy} \#\# \text{Fn HW}\} = \{\text{Psy} \#\# \text{Function of } \textit{Enthalpy and Humidity Ratio}\}$

#### **PsyRhoAirFnPbTdbW (Pb,Tdb,W,calledfrom)**

Returns the density of air in kilograms per cubic meter as a function of barometric pressure [Pb] (in Pascals), dry bulb temperature [Tdb] (in Celsius), and humidity ratio [W] (kilograms of water per kilogram of dry air).

#### **PsyCpAirFnWTdb (W,Tdb,calledfrom)**

Returns the specific heat of air in Joules per kilogram degree Celsius as a function of humidity ratio [W] (kilograms of water per kilogram of dry air) and dry bulb temperature [Tdb] (Celsius).

#### **PsyHfgAirFnWTdb (W,Tdb,calledfrom)**

Returns the Latent energy of air [Hfg](Joules per kilogram) as a function of humidity ratio [W] (kilograms of water per kilogram of dry air) and dry bulb temperature [Tdb] (Celsius). It calculates hg and then hf and the difference is Hfg.

#### **PsyHgAirFnWTdb (W,Tdb,calledfrom)**

Returns the specific enthalpy of the moisture as a gas in the air in Joules per kilogram as a function of humidity ratio [W] (kilograms of water per kilogram of dry air) and dry bulb temperature [Tdb] (Celsius).

#### **PsyTdpFnTdbTwbPb (Tdb,Twb,Pb,calledfrom)**

Returns the dew point temperature in Celsius as a function of dry bulb temperature [Tdb] (Celsius), wet bulb temperature [Twb] (Celsius), and barometric pressure [Pb] (Pascals).

#### **PsyTdpFnWPb (W,Pb,calledfrom)**

Returns the dew point temperature in Celsius as a function of humidity ratio [W] (kilograms of water per kilogram of dry air) and barometric pressure [Pb] (Pascals).

#### **PsyHFnTdbW (Tdb,W,calledfrom)**

Returns the specific enthalpy of air in Joules per kilogram as a function of dry bulb temperature [Tdb] (Celsius) and humidity ratio [W] (kilograms of water per kilogram of dry air).

#### **PsyHFnTdbRhPb (Tdb,Rh,Pb,calledfrom)**

Returns the specific enthalpy of air in Joules per kilogram as a function of dry bulb temperature [Tdb] (Celsius), relative humidity [Rh] (fraction), and barometric pressure [Pb] (Pascals).

**PsyTdbFnHW (H,W,calledfrom)**

Returns the air temperature in Celsius as a function of air specific enthalpy [H] (Joules per kilogram) and humidity ratio [W] (kilograms of water per kilogram of dry air).

**PsyRhovFnTdbRh (Tdb,Rh,calledfrom)**

Returns the Vapor Density in air [RhoVapor](kilograms of water per cubic meter of air) as a function of dry bulb temperature [Tdb](Celsius), Relative Humidity [Rh] (fraction).

**PsyRhovFnTdbWP (Tdb,W,Pb,calledfrom)**

Returns the Vapor Density in air [RhoVapor](kilograms of water per cubic meter of air) as a function of dry bulb temperature [Tdb](Celsius), humidity ratio [W] (kilograms of water per kilogram of dry air) and barometric pressure [Pb] (Pascals).

**PsyRhFnTdbRhov (Tdb,Rhov,calledfrom)**

Returns the Relative Humidity [Rh] (fraction) in air as a function of dry bulb temperature [Tdb] (Celsius) and Vapor Density in air [RhoVapor](kilograms of water per cubic meter of air).

**PsyRhFnTdbWPb (Tdb,W,Pb,calledfrom)**

Returns the relative humidity (fraction) as a function of dry bulb temperature [Tdb] (Celsius), humidity ratio [W] (kilograms of water per kilogram of dry air) and barometric pressure [Pb] (Pascals).

**PsyTwbFnTdbWPb (Tdb,W,Pb,calledfrom)**

Returns the air wet bulb temperature in Celsius as a function of dry bulb temperature [Tdb] (Celsius), humidity ratio [W] (kilograms of water per kilogram of dry air) and barometric pressure [Pb] (Pascals).

**PsyVFnTdbWPb (Tdb,W,Pb,calledfrom)**

Returns the specific volume in cubic meters per kilogram as a function of dry bulb temperature [Tdb] (Celsius), humidity ratio [W] (kilograms of water per kilogram of dry air) and barometric pressure [Pb] (Pascals).

**PsyWFnTdpPb (Tdp,Pb,calledfrom)**

Returns the humidity ratio in kilograms of water per kilogram of dry air as a function of the dew point temperature [Tdp] (Celsius) and barometric pressure [Pb] (Pascals).

**PsyWFnTdbH (Tdb,H,calledfrom)**

Returns the humidity ratio in kilograms of water per kilogram of dry air as a function of dry bulb temperature [Tdb] (Celsius) and air specific enthalpy [H] (Joules per kilogram).

**PsyWFnTdbTwbPb (Tdb,Twb,Pb,calledfrom)**

Returns the humidity ratio in kilograms of water per kilogram of dry air as a function of dry bulb temperature [Tdb] (Celsius), wet bulb temperature [Twb] (Celsius), and barometric pressure [Pb] (Pascals).

**PsyWFnTdbRhPb (Tdb,Rh,Pb,calledfrom)**

Returns the humidity ratio in kilograms of water per kilogram of dry air as a function of dry bulb temperature [Tdb] (Celsius), relative humidity [RH] (fraction), and barometric pressure [Pb] (Pascals).

**PsyPsatFnTemp (T,calledfrom)**

Returns the saturation pressure in Pascals as a function of the air saturation temperature [T] (Celsius).

**PsyTsatFnHPb (H,Pb,calledfrom)**

Returns the air saturation temperature in Celsius as a function of air specific enthalpy [H] (Joules per kilogram) and barometric pressure [Pb] (Pascals).

**PsyTsatFnPb (P,calledfrom)**

Returns the air saturation temperature in Celsius as a function of saturation pressure [P] (Pascals).

**CPCW (Temp,calledfrom)**

Returns Specific heat capacity (Joule/kilogram/kelvin) for chilled water as function of temperature [T] (Celsius).

**CPHW (Temp,calledfrom)**

Returns Specific heat capacity (Joule/kilogram/kelvin) for hot water as function of temperature [T] (Celsius).

**CVHW (Temp,calledfrom)**

Returns Specific heat capacity (Joule/kilogram/kelvin) for hot water at constant volume as function of temperature [T] (Celsius).

**RhoH2O (Temp,calledfrom)**

Returns density of water (kg/m3) as function of Temperature [T] (Celsius).

**Tabular Output Utilities**

Several utility routines are available to help generate tabular reports. To create tabular reports, the developer needs to create a routine called something like WriteTabularX. The WriteTabularX routine should appear in SimulationManger between the OpenOutputTabularFile and CloseOutputTabularFile calls. The WriteTabularX routine should make use of several utilities described below. The "USE" statement reference OutputReportTabular module. Good example of how to use this facility are in the OutputReportTabular file and the EconomicTariff file.

**WriteReportHeaders(reportName,objectName,averageOrSum)**

Where reportName is the name that you want the report to be called and the objectName is the name of the object that appears after the "For: " for each instance of the report. The averageOrSum flag when set to SUM adds the phrase "per second" after the reportName.

**WriteSubtitle(subtitle)**

Where the subtitle is a string that usually appears before a specific table. This is useful if the report includes multiple tables.

**WriteTable(body,rowLabels,columnLabels,widthColumn)**

The WriteTable routine actually generates the tables that appear in the tabular output file (CSV, HTML, or TXT). The rowLabels and columnLabels are both one dimensional string arrays that contain the appropriate labels. If the column labels strings include the vertical bar symbol “|” then when creating a text report, the labels will be split between lines at the vertical bar. For HTML and CSV output, the vertical bar symbols are removed prior to display.

The body array is a two dimensional array (row,column order) containing the cells in the body of the table. It must be strings so conversion utilities such as RealToStr should be used to convert from numeric values.

WidthColumn is a one dimensional integer array containing the column widths for use only with the fixed width text output option.

## HVAC Network

### Branches, Connectors, and Nodes

In EnergyPlus, the HVAC system and plant form a network (technically, a graph). The individual pieces of equipment – the fans, coils, chillers, etc. – are connected together by air ducts and fluid pipes. In EnergyPlus nomenclature, the air and fluid circuits are called loops. Specifying how an individual system and plant are connected is done in the EnergyPlus input (IDF) file. The overall structure of the network is defined with Branch and Connector objects. The detail is filled with components and their inlet and outlet nodes. A Branch consists of one or more components arranged sequentially along a pipe or duct. A Connector specifies how three or more branches are connected through a Splitter or Mixer. Nodes connect components along a branch: the outlet node of one component is the inlet node of the next downstream component. The nodes represent conditions at a point on a loop. Each component has one or more inlet and outlet nodes, depending on how many loops it interacts with. A fan, for instance, has one inlet node and one outlet node, since it interacts with a single air loop. A water coil will have 2 inlet and 2 outlet nodes, since it interacts with an air and a fluid loop. Figure 1 shows a diagram of an EnergyPlus HVAC input.

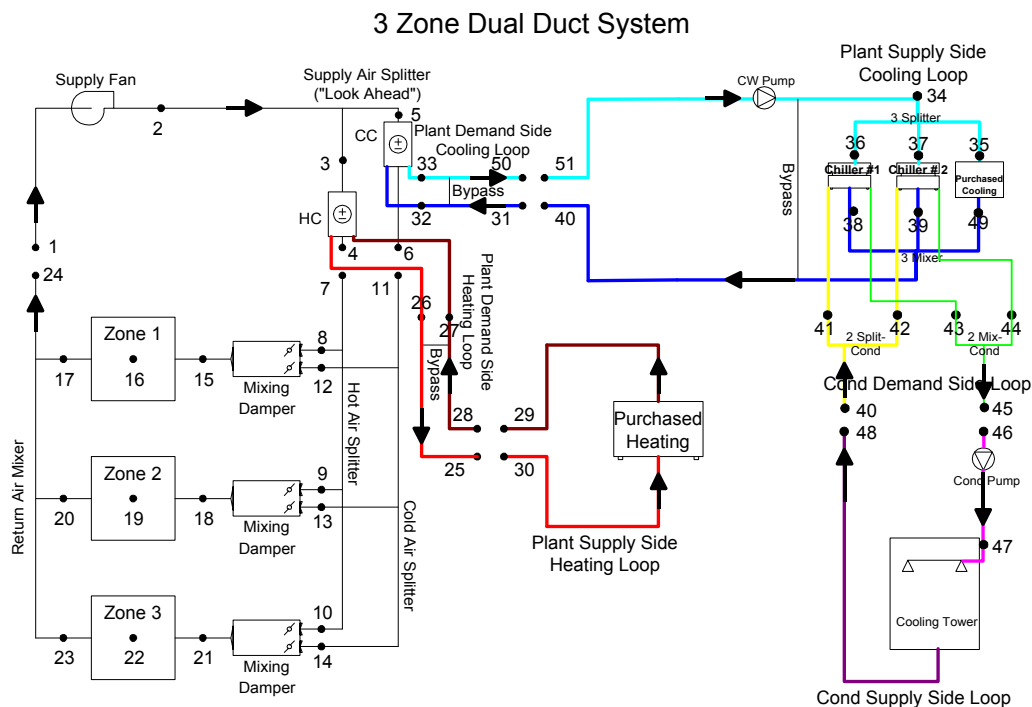

Figure 1. HVAC Input Diagram

As an illustration of how such a network is built up on the IDF, here is the section of the IDF that describes the supply fan, splitter, and heating and cooling coil section of the dual duct air system.



```

BranchList,
    Dual Duct Air Loop Branches,  !- Name
    Air Loop Main Branch,        !- Branch 1 Name
    Heating Coil Air Sys Branch,  !- Branch 2 Name
    Cooling Coil Air Sys Branch;  !- Branch 3 Name

ConnectorList,
    Dual Duct Connectors,        !- Name
    Connector:Splitter,          !- Connector 1 Object Type
    DualDuctAirSplitter;         !- Connector 1 Name

NodeList,
    Zone Equipment Inlet Node List, !- Name
    Main Hot Air Inlet,           !- Node 1 Name
    Main Cold Air Inlet;         !- Node 2 Name

NodeList,
    Air Loop Outlet Node List,    !- Name
    Heating Coil Outlet Node, !- Node 1 Name
    Cooling Coil Outlet Node; !- Node 2 Name

Branch,
    Air Loop Main Branch,        !- Name
    autosize,                    !- Maximum Flow Rate {m3/s}
    Fan:ConstantVolume,          !- Component 1 Object Type
    Supply Fan 1,                !- Component 1 Name
    Supply Fan Inlet Node,        !- Component 1 Inlet Node Name
    Supply Fan Outlet Node,       !- Component 1 Outlet Node Name
    PASSIVE;                      !- Component 1 Branch Control Type

Branch,
    Heating Coil Air Sys Branch,  !- Name
    autosize,                    !- Maximum Flow Rate {m3/s}
    Coil:Heating:Water,          !- Component 1 Object Type
    Main Heating Coil,           !- Component 1 Name
    Heating Coil Inlet Node,     !- Component 1 Inlet Node Name
    Heating Coil Outlet Node,    !- Component 1 Outlet Node Name
    ACTIVE;                      !- Component 1 Branch Control Type

Branch,
    Cooling Coil Air Sys Branch,  !- Name
    autosize,                    !- Maximum Flow Rate {m3/s}
    Coil:Cooling:Water,          !- Component 1 Object Type
    Simple Cooling Coil,         !- Component 1 Name
    Cooling Coil Inlet Node,     !- Component 1 Inlet Node Name
    Cooling Coil Outlet Node,    !- Component 1 Outlet Node Name
    ACTIVE;                      !- Component 1 Branch Control Type

Connector:Splitter,
    DualDuctAirSplitter,        !- Name
    Air Loop Main Branch,        !- Inlet Branch Name
    Heating Coil Air Sys Branch, !- Outlet Branch 1 Name
    Cooling Coil Air Sys Branch; !- Outlet Branch 2 Name

Fan:ConstantVolume,
    Supply Fan 1,                !- Name
    FanAndCoilAvailSched,        !- Availability Schedule Name
    0.7,                          !- Fan Efficiency
    600.0,                        !- Pressure Rise {Pa}
    autosize,                    !- Maximum Flow Rate {m3/s}
    0.9,                          !- Motor Efficiency
    1.0,                          !- Motor In Airstream Fraction
    Supply Fan Inlet Node,        !- Fan Inlet Node Name

```

```

Supply Fan Outlet Node;  !- Fan Outlet Node Name

Coil:Cooling:Water,
Simple Cooling Coil,      !- Name
CoolingCoilAvailSched,   !- Availability Schedule Name
autosize,                 !- Design Water Flow Rate {m3/s}
autosize,                 !- Design Air Flow Rate {m3/s}
autosize,                 !- Design Inlet Water Temperature {C}
autosize,                 !- Design Inlet Air Temperature {C}
autosize,                 !- Design Outlet Air Temperature {C}
autosize,                 !- Design Inlet Air Humidity Ratio {kg-H2O/kg-air}
autosize,                 !- Design Outlet Air Humidity Ratio {kg-H2O/kg-air}
Cooling Coil Water Inlet Node, !- Water Inlet Node Name
Cooling Coil Water Outlet Node, !- Water Outlet Node Name
Cooling Coil Inlet Node, !- Air Inlet Node Name
Cooling Coil Outlet Node, !- Air Outlet Node Name
SimpleAnalysis,          !- Type of Analysis
CrossFlow;              !- Heat Exchanger Configuration

AirLoopHVAC:ZoneSplitter,
ZoneColdAirSupplySplitter, !- Name
Main Cold Air Inlet,       !- Inlet Node Name
Zone 1 Dual Duct Cold Inlet, !- Outlet 1 Node Name
Zone 2 Dual Duct Cold Inlet, !- Outlet 2 Node Name
Zone 3 Dual Duct Cold Inlet; !- Outlet 3 Node Name

AirLoopHVAC:ZoneSplitter,
ZoneHotAirSupplySplitter, !- Name
Main Hot Air Inlet,       !- Inlet Node Name
Zone 1 Dual Duct Hot Inlet, !- Outlet 1 Node Name
Zone 2 Dual Duct Hot Inlet, !- Outlet 2 Node Name
Zone 3 Dual Duct Hot Inlet; !- Outlet 3 Node Name

AirLoopHVAC:ZoneMixer,
ZoneReturnAirMixer,      !- Name
Return Air Mixer Outlet, !- Outlet Node Name
Zone 1 Outlet Node,      !- Inlet 1 Node Name
Zone 2 Outlet Node,      !- Inlet 2 Node Name
Zone 3 Outlet Node;      !- Inlet 3 Node Name

Coil:Heating:Water,
Main Heating Coil,       !- Name
FanAndCoilAvailSched,   !- Availability Schedule Name
autosize,                 !- U-Factor Times Area Value {W/K}
autosize,                 !- Maximum Water Flow Rate {m3/s}
Heating Coil Water Inlet, !- Water Inlet Node Name
Heating Coil Water Outlet, !- Water Outlet Node Name
Heating Coil Inlet Node, !- Air Inlet Node Name
Heating Coil Outlet Node, !- Air Outlet Node Name
UFactorTimesAreaAndDesignWaterFlowRate, !- Performance Input
Method
autosize,                 !- Nominal Capacity {W}
82.2,                     !- Design Inlet Water Temperature {C}
16.6,                     !- Design Inlet Air Temperature {C}
71.1,                     !- Design Outlet Water Temperature {C}
32.2;                     !- Design Outlet Air Temperature {C}

Controller:WaterCoil,
Main Cooling Coil Controller, !- Name
Temperature,              !- Control Variable
Reverse,                  !- Action
FLOW,                     !- Actuator Variable
Cooling Coil Outlet Node, !- Sensor Node Name

```

```

Cooling Coil Water Inlet Node,  !- Actuator Node Name
0.001,                          !- Controller Convergence Tolerance {deltaC}
autosize,                        !- Maximum Actuated Flow {m3/s}
0.0;                             !- Minimum Actuated Flow {m3/s}

Controller:WaterCoil,
  Main Heating Coil Controller,  !- Name
  Temperature,                  !- Control Variable
  Normal,                       !- Action
  FLOW,                          !- Actuator Variable
  Heating Coil Outlet Node, !- Sensor Node Name
  Heating Coil Water Inlet, !- Actuator Node Name
  0.01,                          !- Controller Convergence Tolerance {deltaC}
  autosize,                      !- Maximum Actuated Flow {m3/s}
  0.0;                            !- Minimum Actuated Flow {m3/s}

```

Obviously, the creation of such a system/plant network description is best handled by a graphical user interface (GUI). However, for testing purposes a developer may have to create the input for a component by hand and insert it into an existing IDF. Then the developer must be careful to choose unique names for the branches and nodes and make sure the entire network makes physical sense.

### Nodes in the simulation

In the EnergyPlus data structure, the nodes are where each component model gets its input and where it places its output. The module *DataLoopNode* contains all the node related data. In particular, the array *Node* contains the state variables and mass flows for all the nodes in the problem being simulated.

```

! Valid Fluid Types for Nodes
INTEGER, PARAMETER :: NodeType_Unknown = 0 ! 'blank'
INTEGER, PARAMETER :: NodeType_Air     = 1 ! 'Air'
INTEGER, PARAMETER :: NodeType_Water   = 2 ! 'Water'
INTEGER, PARAMETER :: NodeType_Steam   = 3 ! 'Steam'
INTEGER, PARAMETER :: NodeType_Electric= 4 ! 'Electric'

```

```

TYPE NodeData
  INTEGER :: FluidType           = 0 ! must be one of the valid parameters
  INTEGER :: FluidIndex          = 0 ! For Fluid Properties
  REAL(r64):: Temp                = 0.0 ! {C}
  REAL(r64):: TempMin             = 0.0 ! {C}
  REAL(r64):: TempMax             = 0.0 ! {C}
  REAL(r64):: TempSetPoint        = SensedNodeFlagValue ! {C}
  REAL(r64):: MassFlowRate        = 0.0 ! {kg/s}
  REAL(r64):: MassFlowRateMin     = 0.0 ! {kg/s}
  REAL(r64):: MassFlowRateMax     = 0.0 ! {kg/s}
  REAL(r64):: MassFlowRateMinAvail = 0.0 ! {kg/s}
  REAL(r64):: MassFlowRateMaxAvail = 0.0 ! {kg/s}
  REAL(r64):: MassFlowRateSetPoint = 0.0 ! {kg/s}
  REAL(r64):: Quality              = 0.0 ! {0.0-1.0 vapor fraction/percent}
  REAL(r64):: Press                = 0.0 ! {Pa}
  REAL(r64):: Enthalpy             = 0.0 ! {J/kg}
  REAL(r64):: HumRat               = 0.0 ! {}
  REAL(r64):: HumRatMin            = SensedNodeFlagValue ! {}
  REAL(r64):: HumRatMax            = SensedNodeFlagValue ! {}
  REAL(r64):: HumRatSetPoint        = SensedNodeFlagValue ! {}
  REAL(r64):: TempSetPointHi       = 0.0 ! {C}
  REAL(r64):: TempSetPointLo       = 0.0 ! {C}
  REAL(r64):: Height                = -1.0 ! {m}
  ! Following are for Outside Air Nodes "read only"
  REAL(r64):: OutAirDryBulb         = 0.0 ! {C}
  REAL(r64):: OutAirWetBulb         = 0.0 ! {C}
END TYPE NodeData

```

```

TYPE MoreNodeData
  REAL(r64):: RelHumidity           = 0.0 ! {}
  REAL(r64):: ReportEnthalpy        = 0.0 ! specific enthalpy calculated at the HVAC timestep [J/kg]
  REAL(r64):: VolFlowRate           = 0.0 ! volume flow rate [m3/s]
  REAL(r64):: WetbulbTemp           = 0.0 ! wetbulb temperature [C]
END TYPE MoreNodeData

TYPE (NodeData), ALLOCATABLE, DIMENSION(:) :: Node !dim to num nodes in SimHVAC
TYPE (NodeData) :: DefaultNodeValues= &
  NodeData(0, & ! FluidType
    0, & ! FluidIndex
    0.0, & ! Temp {C}
    0.0, & ! TempMin {C}
    0.0, & ! TempMax {C}
    SensedNodeFlagValue, & ! TempSetPoint {C}
    0.0, & ! MassFlowRate {kg/s}
    0.0, & ! MassFlowRateMin {kg/s}
    0.0, & ! MassFlowRateMax {kg/s}
    0.0, & ! MassFlowRateMinAvail {kg/s}
    0.0, & ! MassFlowRateMaxAvail {kg/s}
    0.0, & ! MassFlowRateSetPoint {kg/s}
    0.0, & ! Quality {0.0-1.0 vapor fraction/percent}
    0.0, & ! Press {Pa} REAL ::
    0.0, & ! Enthalpy {J/kg}
    0.0, & ! HumRat {}
    SensedNodeFlagValue, & ! HumRatMin {}
    SensedNodeFlagValue, & ! HumRatMax {}
    SensedNodeFlagValue, & ! HumRatSetPoint {}
    0.0, & ! TempSetPointHi {C}
    0.0, & ! TempSetPointLo {C}
    -1.0, & ! Height {m}
    0.0, & ! OutAirDryBulb {C}
    0.0) ! OutAirWetBulb {C}

TYPE (MoreNodeData), ALLOCATABLE, DIMENSION(:) :: MoreNodeInfo

```

In our example module *NewHVACComponent*, the subroutine *InitNewHVACComponent* is responsible for obtaining the input data from the inlet node(s) and putting it into the component data structure for use in *CalcNewHVACComponent*. Then *UpdateNewHVACComponent* takes the calculated data and moves it to the outlet nodes for use by other

components. EnergyPlus component models are assumed to be direct models: inlets are input to the calculation and outlets are output from the calculations.

## Getting Nodes

### Data Flow in an HVAC Component Module

The data in an EnergyPlus HVAC component module resides in three places.

1. The component inlet nodes – this is where the data input to the model resides.
2. The component internal data structure(s) – one or more arrays of data structures which contain all the data needed for the component simulation. This includes data from the input file, data from the inlet nodes, and any schedule values. In addition, these data structure(s) store the results of the calculation.
3. The component outlet nodes – data is moved from the internal data structure(s) to the outlet nodes at the completion of each component simulation.

The data flows from the inlet nodes into the component internal data structure(s) and then into the outlet nodes. Let us see how this works in our example module Fans.

At the start of the module, the component internal data structure is defined.

```

TYPE FanEquipConditions
  CHARACTER(len=MaxNameLength) :: FanName ! Name of the fan
  CHARACTER(len=MaxNameLength) :: FanType ! Type of Fan ie. Simple, Vane axial, Centrifugal, etc.
  CHARACTER(len=MaxNameLength) :: Schedule ! Fan Operation Schedule
  CHARACTER(len=MaxNameLength) :: Control ! ie. Const Vol, Variable Vol
  Integer :: SchedPtr ! Pointer to the correct schedule
  REAL(r64) :: InletAirMassFlowRate !MassFlow through the Fan being Simulated [kg/Sec]
  REAL(r64) :: OutletAirMassFlowRate
  REAL(r64) :: MaxAirFlowRate !Max Specified Volume Flow Rate of Fan [m^3/sec]
  REAL(r64) :: MinAirFlowRate !Min Specified Volume Flow Rate of Fan [m^3/sec]
  REAL(r64) :: MaxAirMassFlowRate ! Max flow rate of fan in kg/sec
  REAL(r64) :: MinAirMassFlowRate ! Min flow rate of fan in kg/sec
  REAL(r64) :: InletAirTemp
  REAL(r64) :: OutletAirTemp
  REAL(r64) :: InletAirHumRat
  REAL(r64) :: OutletAirHumRat
  REAL(r64) :: InletAirEnthalpy
  REAL(r64) :: OutletAirEnthalpy
  REAL(r64) :: FanPower !Power of the Fan being Simulated [kW]
  REAL(r64) :: FanEnergy !Fan energy in [kJ]
  REAL(r64) :: DeltaTemp !Temp Rise across the Fan [C]
  REAL(r64) :: DeltaPress !Delta Pressure Across the Fan [N/M^2]
  REAL(r64) :: FanEff !Fan total efficiency; motor and mechanical
  REAL(r64) :: MotEff !Fan motor efficiency
  REAL(r64) :: MotInAirFrac !Fraction of motor heat entering air stream
  REAL(r64), Dimension(5):: FanCoeff !Fan Part Load Coefficients to match fan type
  ! Mass Flow Rate Control Variables
  REAL(r64) :: MassFlowRateMaxAvail
  REAL(r64) :: MassFlowRateMinAvail
  INTEGER :: InletNodeNum
  INTEGER :: OutletNodeNum
END TYPE FanEquipConditions

!MODULE VARIABLE DECLARATIONS:
INTEGER :: NumFans ! The Number of Fans found in the Input
TYPE (FanEquipConditions), ALLOCATABLE, DIMENSION(:) :: Fan

```

In this case, there is only one structure that stores all of the fan data. We could have chosen to divide this rather large structure up into separate

structures – one for input file data, one for inlet data, and one for outlet data, for instance. Note that in Fortran 90 structures are called defined type. The TYPE – END TYPE construct defines a new data structure. Then an allocatable array *Fan* of the defined type is created. This one-dimensional array will contain an entry for each fan in the problem.

The internal data array is allocated (sized) in the “GetInput” routine GetFanInput.

```

NumSimpFan = GetNumObjectsFound('FAN:SIMPLE:CONSTVOLUME')
NumVarVolFan = GetNumObjectsFound('FAN:SIMPLE:VARIABLEVOLUME')
NumOnOff = GetNumObjectsFound('FAN:SIMPLE:ONOFF')
NumZoneExhFan = GetNumObjectsFound('ZONE EXHAUST FAN')
NumFans = NumSimpFan + NumVarVolFan + NumZoneExhFan+NumOnOff
IF (NumFans.GT.0) ALLOCATE (Fan (NumFans))

```

The remainder of the “GetInput” routine moves input file data into the Fan array. The “Init” routine transfers data from the inlet nodes into the same array in preparation for performing the calculation.

```

! Load the node data in this section for the component simulation
!
!First need to make sure that the massflowrate is between the max and min avail.
IF (Fan(FanNum)%FanType .NE. 'ZONE EXHAUST FAN') THEN
  Fan(FanNum)%InletAirMassFlowRate = Min(Node(InletNode)%MassFlowRate, &
    Fan(FanNum)%MassFlowRateMaxAvail)
  Fan(FanNum)%InletAirMassFlowRate = Max(Fan(FanNum)%InletAirMassFlowRate, &
    Fan(FanNum)%MassFlowRateMinAvail)
ELSE ! zone exhaust fans - always run at the max
  Fan(FanNum)%MassFlowRateMaxAvail = Fan(FanNum)%MaxAirMassFlowRate
  Fan(FanNum)%MassFlowRateMinAvail = 0.0
  Fan(FanNum)%InletAirMassFlowRate = Fan(FanNum)%MassFlowRateMaxAvail
END IF

!Then set the other conditions
Fan(FanNum)%InletAirTemp = Node(InletNode)%Temp
Fan(FanNum)%InletAirHumRat = Node(InletNode)%HumRat
Fan(FanNum)%InletAirEnthalpy = Node(InletNode)%Enthalpy

```

The “Calc” routines do the actual component simulation. All the data they need has been stored in the internal data array ready to be used. The results of the calculation are, in this case, stored in the same array. The “Calc” routine always does pure calculation/simulation – it never retrieves or stores data.

```

DeltaPress = Fan(FanNum)%DeltaPress
FanEff      = Fan(FanNum)%FanEff

! For a Constant Volume Simple Fan the Max Flow Rate is the Flow Rate for the fan
Tin         = Fan(FanNum)%InletAirTemp
Win         = Fan(FanNum)%InletAirHumRat
RhoAir      = Fan(FanNum)%RhoAirStdInit
MassFlow    = MIN(Fan(FanNum)%InletAirMassFlowRate, Fan(FanNum)%MaxAirMassFlowRate)
MassFlow    = MAX(MassFlow, Fan(FanNum)%MinAirMassFlowRate)
!
!Determine the Fan Schedule for the Time step
If( ( GetCurrentScheduleValue(Fan(FanNum)%SchedPtr)>0.0 .and. Massflow>0.0 .or. TurnFansOn .and.
Massflow>0.0) &
.and. .NOT.TurnFansOff ) Then
!Fan is operating
Fan(FanNum)%FanPower = MassFlow*DeltaPress/(FanEff*RhoAir) ! total fan power
FanShaftPower = Fan(FanNum)%MotEff * Fan(FanNum)%FanPower ! power delivered to shaft
PowerLossToAir = FanShaftPower + (Fan(FanNum)%FanPower - FanShaftPower) * &
Fan(FanNum)%MotInAirFrac
Fan(FanNum)%OutletAirEnthalpy = Fan(FanNum)%InletAirEnthalpy + PowerLossToAir/MassFlow
! This fan does not change the moisture or Mass Flow across the component
Fan(FanNum)%OutletAirHumRat = Fan(FanNum)%InletAirHumRat
Fan(FanNum)%OutletAirMassFlowRate = MassFlow
Fan(FanNum)%OutletAirTemp = PsyTdbFnHW
(Fan(FanNum)%OutletAirEnthalpy, Fan(FanNum)%OutletAirHumRat)

Else
!Fan is off and not operating no power consumed and mass flow rate.
Fan(FanNum)%FanPower = 0.0
FanShaftPower = 0.0
PowerLossToAir = 0.0
Fan(FanNum)%OutletAirMassFlowRate = 0.0
Fan(FanNum)%OutletAirHumRat = Fan(FanNum)%InletAirHumRat
Fan(FanNum)%OutletAirEnthalpy = Fan(FanNum)%InletAirEnthalpy
Fan(FanNum)%OutletAirTemp = Fan(FanNum)%InletAirTemp
! Set the Control Flow variables to 0.0 flow when OFF.
Fan(FanNum)%MassFlowRateMaxAvail = 0.0
Fan(FanNum)%MassFlowRateMinAvail = 0.0

End If

```

Finally, the “Update” routine (UpdateFan) moves the results from the internal data array into the outlet node(s).

```

OutletNode = Fan(FanNum)%OutletNodeNum
InletNode = Fan(FanNum)%InletNodeNum

! Set the outlet air nodes of the fan
Node(OutletNode)%MassFlowRate = Fan(FanNum)%OutletAirMassFlowRate
Node(OutletNode)%Temp = Fan(FanNum)%OutletAirTemp
Node(OutletNode)%HumRat = Fan(FanNum)%OutletAirHumRat
Node(OutletNode)%Enthalpy = Fan(FanNum)%OutletAirEnthalpy
! Set the outlet nodes for properties that just pass through & not used
Node(OutletNode)%Quality = Node(InletNode)%Quality
Node(OutletNode)%Press = Node(InletNode)%Press

! Set the Node Flow Control Variables from the Fan Control Variables
Node(OutletNode)%MassFlowRateMaxAvail = Fan(FanNum)%MassFlowRateMaxAvail
Node(OutletNode)%MassFlowRateMinAvail = Fan(FanNum)%MassFlowRateMinAvail

```

Certain data items must always be transferred from inlet nodes to outlet nodes even if the data item is unaltered by the component model. The data items that must be transferred are:

1. Temp
2. HumRat

3. Enthalpy
4. Press
5. MassFlowRate
6. MassFlowRateMaxAvail
7. MassFlowRateMinAvail

### **Node Mass Flow Variables**

The node mass flow variables merit a little more discussion. Five mass flow variables are defined at each node. They are: MassFlowRate, MassFlowRateMin, MassFlowRateMax, MassFlowRateMinAvail and MassFlowRateMaxAvail. These variables hold loop mass flow rate information according to the following definitions.

- MassFlowRate – this node variable holds the simulation mass flow rate for the current timestep. The component simulation retrieves this mass flow rate from its inlet node (“Init” routine) and uses it as the initial mass flow rate in the simulation. The component simulation may or may not change the mass flow rate. In any case, it writes the value out to the exit node in the “Update” routine. If the component model is on the demand side of a plant loop and includes some sort of integral controller that modulates flow rates (i.e. calculates flow rate), then the component model should set the value for MassFlowRate on both the inlet and the outlet. The value for MassFlowRate on the inlet node is used to communicate flow requests to the plant solver. The remaining four variables serve as limits to MassFlowRate.
- MassFlowRateMax, MassFlowRateMin – These node variables hold the maximum possible and the minimum allowable flow rates for a particular component. As such, they represent the “hardware limit” on the flow rate for the component. By convention, these variables are stored at the component outlet node. Since components share their nodes (the outlet node of one component is the inlet node of the next component), the protocol must be strictly followed. These variables are set by each component at the beginning of the simulation and are never reset thereafter.
- MassFlowRateMaxAvail, MassFlowRateMinAvail – these node variables represent the *loop* maximum and minimum flow rate for the current configuration of the loop on which the component resides. If for whatever reason the plant is configured so that (because of continuity) a component cannot receive all the flow it has requested (or will get more than it has requested), then these variables carry important flow information from the plant flow solver back to the component models. The component model interacts with these variables differently depending on where the simulation is in terms of system iterations. At the beginning of a system time step (FirstHVACIteration = .true.), the component models should reset the values for MassFlowRateMaxAvail and MassFlowRateMinAvail, typically to the hardware limits. Later on during subsequent iterations (FirstHVACIteration = .false.) the component model should read the current loop min/max available flow rate from its inlet node (“Init” routine) and use these limits to constrain MassFlowRate. All components should also honor the hardware limits and change the max/min available values so that they lie within the max/min flow rate range for the component. The component model also writes the updated min/max available flow rate to its outlet node (“Update” routine).



During the first HVAC iteration, the component simulation needs to reset values for `MassFlowRateMinAvail` and `MassFlowRateMaxAvail`. Often this is done by the component's companion controller (see Subroutine `ControlCompOutput` or input object `Controller:Simple`). If the component does not repeatedly set these, then they are likely to get ratcheted down to zero at some point by the plant solver.

After the first HVAC iteration, the component simulation retrieves `MassFlowRate`, `MassFlowRateMinAvail`, and `MassFlowRateMaxAvail` along with other node variables from its input node prior to the simulation of the component. The flow rate must be checked and if necessary adjusted prior to the simulation: the `MassFlowRate` must be bounded by `MassFlowRateMaxAvail` and `MassFlowRateMinAvail`, which in turn must be bounded by `MassFlowRateMax` and `MassFlowRateMin` for the component. The following steps should be followed in the initialization stage of the component simulation.

- a) Compare the `MassFlowRateMinAvail` and `MassFlowRateMaxAvail` retrieved from the input node with the `MassFlowRateMin` and `MassFlowRateMax` for your component. If either of the retrieved values is out of bounds, replace that value with either the Max or Min for the component.
- b) Compare the `MassFlowRate` retrieved from the inlet node with the `MassFlowRateMinAvail` and `MassFlowRateMaxAvail`. If `MassFlowRate` is not bounded by `MassFlowRateMinAvail` and `MassFlowRateMaxAvail`, reset `MassFlowRate` to the nearest boundary value.

If the component model calculates `MassFlowRate`, it must be bounded by `MassFlowRateMin` and `MassFlowRateMax`. Following the component simulation, the `MassFlowRate` and the bounding `MassFlowRateMinAvail` and `MassFlowRateMaxAvail` should be written to the outlet node along with the other updated loop variables.

## Output

There are several output files available in EnergyPlus. As you can see in Appendix A, DataGlobals contains OutputFileStandard, OutputFileInits, and OutputFileDebug.

OutputFileDebug is initialized very early in the EnergyPlus execution and is available for any debugging output the developer might need.

OutputFileInits is intended for “one-time” outputs. If the value is calculated or entered and should be echoed to output, this file is the place for it. The structure is similar to the IDD/IDF structure in that there is a “definition” line followed by the data being reported. Since the data may be produced in several places during the simulation, the actual file looks a bit hodge-podge but can be easily imported into a spreadsheet program and grouped.

OutputFileStandard is the reporting variable output file from EnergyPlus. You can read more details from the [Guide for Interface Developers](#) document and in the [Input Output Reference](#) document. OutputFileMeters is a similar file to contain meter (only) output. Meter values also may appear in the OutputFileStandard file. Only values that change during the simulation should be output to these files. They are automatically included by the SetupOutputVariable calls.

### How Do I Output My Variables?

Module developers are responsible for “setting” up the variables that will appear in the OutputFileStandard.

To do this is very simple. All you need to do is place a simple call to *SetupOutputVariable* into your module for each variable to be available for reporting. This call should be done only once for each Variable/KeyedValue pair (see below). For HVAC and Plant components, this call is usually at the end of the “GetInput” subroutine. See the example module for an illustration of this. Other calls in the simulation routines will invoke the EnergyPlus *OutputProcessor* automatically at the proper time to have the data appear in the OutputFileStandard.

For you the call is:

```
Call SetupOutputVariable(VariableName,ActualVariable, &
                        IndexTypeKey, VariableTypeKey,KeyedValue,ReportFreq &
                        ResourceTypeKey,EndUseKey,GroupKey)
```

Interface statements allow for the same call to be used for either real or integer “ActualVariable” variables. A few examples from EnergyPlus and then we will define the arguments:

```
CALL SetupOutputVariable('Outdoor Dry Bulb [C]', &
                        OutDryBulbTemp,'Zone', &
                        'Average','Environment')

CALL SetupOutputVariable('Mean Air Temperature[C]', &
                        ZnRpt(Loop)%MeanAirTemp,'Zone', &
                        'State',Zone(Loop)%Name)

CALL SetupOutputVariable('Fan Coil Heating Energy[J]', &
                        FanCoil(FanCoilNum)%HeatEnergy,'System', &
```

```

        'Sum', FanCoil (FanCoilNum) %Name)
CALL SetupOutputVariable('Humidifier Electric Consumption[J]',
    Humidifier (HumNum) %ElecUseEnergy, &
    'System', 'Sum', &
    Humidifier (HumNum) %Name, &
    ResourceTypeKey='ELECTRICITY', &
    EndUseKey = 'HUMIDIFIER', &
    GroupKey = 'System')

```

Table 3. SetupOutputVariable Arguments

SetupOutput Variable Arguments	Description
VariableName	String name of variable, units should be included in []. If no units, use []
ActualVariable	This should be the actual variable that will store the value. The OutputProcessor sets up a pointer to this variable, so it will need to be a SAVEd variable if in a local routine. As noted in examples, can be a simple variable or part of an array/derived type.
IndexTypeKey	When this variable has its proper value. 'Zone' is used for variables that will have value on the global timestep (alias "HeatBalance"). 'HVAC' is used for variables that will have values calculated on the variable system timesteps (alias "System", "Plant")
VariableTypeKey	Two kinds of variables are produced. 'State' or 'Average' are values that are instantaneous at the timestep (zone air temperature, outdoor weather conditions). 'NonState' or 'Sum' are values which need to be summed for a period (energy).
KeyedValue	Every variable to be reported needs to have an associated keyed value. Zone Air Temperature is available for each Zone, thus the keyed value is the Zone Name.
ReportFreq	This optional argument should only be used during debugging of your module but it is provided for the developers so that these variables would always show up in the OutputFile. (All other variables must be requested by the user).
ResourceTypeKey	Meter Resource Type; an optional argument used for including the variable in a meter. The meter resource type can be 'Electricity', 'Gas', 'Coal', 'FuelOil#1', 'FuelOil#2', 'Propane', 'Water', or 'EnergyTransfer'.
EndUseKey	Meter End Use Key; an optional argument used when the variable is included in a meter. The end use keys can be: 'InteriorLights', 'ExteriorLights', 'Heating', 'Cooling', 'DHW', 'Cogeneration', 'ExteriorEquipment', 'ZoneSource', 'PurchasedHotWater', 'PurchasedChilledWater', 'Fans', 'HeatingCoils', 'CoolingCoils', 'Pumps', 'Chillers', 'Boilers', 'Baseboard', 'HeatRejection', 'Humidifier', 'HeatRecovery' or 'Refrigeration'.
EndUseSubKey	Meter End Use Subcategory Key; an optional argument to further divide a particular End Use. This key is user-defined in the input object and can be any string, e.g., 'Task Lights', 'Exit

	Lights', 'Landscape Lights', 'Computers', or 'Fax Machines'.
GroupKey	Meter Super Group Key; an optional argument used when the variable is included in a meter. The group key denotes whether the variable belongs to the building, system, or plant. The choices are: 'Building', 'HVAC' or 'Plant'.

As described in the *Input Output Reference*, not all variables may be available in any particular simulation. Only those variables that will have values generated will be available for reporting. In the IDF, you can include a “Output:VariableDictionary,regular;” command that will produce the eplusout.rdd file containing all the variables with their IndexTypeKeys. This list can be used to tailor the requests for values in the OutputFileStandard.

This variable dictionary is separated into two pieces: regular reporting variables and meter variables. It can also be sorted by name (ascending).

## Output Variable Dos and Don'ts

For general output variables there aren't many rules. For meter output variables there are quite a few. Here are some tips to keep you out of trouble.

### What Variables Should I Output?

The choice of variables to output is really up to the developer. Since variables don't appear on the output file unless requested by the user in the IDF input file, it is better to “SetUp” too many rather than too few. For an HVAC component one should generally output the heating and cooling outputs of the component both in terms of energy and power. Energy is always output in Joules, power in Watts. If there is humidification or dehumidification both total and sensible cooling should be reported. Any electricity or fuel consumed by a component should be reported out, again both in terms of energy (Joules) and power (Watts). For HVAC components in most cases reporting inlet and outlet temperatures and humidities is unnecessary since these quantities can be obtained from the system node outputs.

### Output Variable Naming Conventions

We have tried to obtain some consistency in variable names by defining some naming conventions. The heating and/or cooling output is always reported as:

```
<component-type> Heating Rate[W]
<component-type> Heating Energy[J]
<component-type> Total Cooling Rate[W]
<component-type> Total Cooling Energy[W]
<component-type> Sensible Cooling Rate[W]
<component-type> Sensible Cooling Energy[J]
```

Fuel and electricity consumption is reported as:

```
<component-type> Electric Power[W]
<component-type> Electric Consumption[J]
<component-type> Gas Consumption Rate[W]
<component-type> Gas Consumption[J]
```

Water addition is reported as:

```
<component-type> Water Consumption Rate[m3/s]
<component-type> Water Consumption[m3]
```

Units are always strictly SI and no abbreviations are allowed in the variable name. <component-type> is the type of component. It should not be the actual object class name from the IDD file, but rather one step of generality above this. For example for fancoils we have:

```
Fan Coil Total Cooling Energy[J]
```

Here <component-type> is “Fan Coil”, not FAN COIL UNIT:4 PIPE.

### What are Meters?

In EnergyPlus meters are an additional output reporting capability. A meter is a way of grouping similar output variables. Meters are output variables just like ordinary output variables except that they sum or average a collection of ordinary output variables. In EnergyPlus the meter variables serve two purposes.

1. Providing output of fuel and electricity consumption by end use categories and at the system plant, building and facility level.
2. Providing a way of summing heating or cooling outputs for a category of components. The resource type EnergyTransfer is used for this purpose. An example would be reporting out the sum of the heating energy from all the heating coils in a system.

### How Do I Create A Meter?

Meter output variables are created at the same time and in the same manner as ordinary output variables. SetupOutputVariable is called but the optional arguments ResourceTypeKey, EndUseKey, and GroupKey must be used in addition to the usual arguments. For example, in the electric steam humidifier module

```
CALL SetupOutputVariable('Humidifier Electric Consumption[J]', &
  Humidifier(HumNum)%ElecUseEnergy, 'System','Sum', &
  Humidifier(HumNum)%Name)
```

creates an output variable labeled 'Humidifier Electric Consumption[J]' with the value of Humidifier(HumNum)%ElecUseEnergy.

```
CALL SetupOutputVariable('Humidifier Electric Consumption[J]', &
  Humidifier(HumNum)%ElecUseEnergy, 'System','Sum', &
  Humidifier(HumNum)%Name, &
  ResourceTypeKey='ELECTRICITY',EndUseKey = 'HUMIDIFIER', &
  GroupKey = 'System')
```

Creates the same output variable but in addition creates a meter output variable Humidifier:Electricity [J]. This variable will contain the sum of all the electricity consumption of the humidifiers in the system. In addition, this electrical consumption will be added into the meter variables Electricity:HVAC [J] and Electricity:Facility [J].

### Rules for Meter Variables

There are a number of rules developers must follow in order to account for all electricity and fuel consumption as well as to prevent consumables from being double counted.

- ◆ Electricity and fuel meters must always be defined at the simple component level. Some EnergyPlus components are compound components: they are built up from simple components. Examples are fan

coils (composed of heating coils, cooling coils, and fans), terminal units etc. Some example simple components are heating and cooling coils, fans, humidifiers etc. Electricity and fuel consumption should always be metered at the simple component level and never at the compound component level. This prevents double counting of the fuel or energy consumption.

- ◆ A variable should be metered once only. This means a variable can be assigned to only one resource type and to only one end use category.
- ◆ Energy Transfer should be metered in the same way as fuel or electricity use. Energy Transfer meters should only be defined for simple components and should be assigned the same end use category as the fuel or electricity consumption.
- ◆ All fuel and electricity consumption must be put in some (one) meter.
- ◆ Use Energy Transfer judiciously; if in doubt, leave it out.

## Running/Testing EnergyPlus – for Developers

Any item mentioned in this section is available at no charge to collaborative or other developers – the documentation, however, may be rudimentary and use of the procedures require some knowledge of command line (Windows) or Linux scripts.

EnergyPlus is rigorously tested during each release cycle and prior to each release. Details on some of the test suites that have been used can be seen at:

<http://www.eere.energy.gov/buildings/energyplus/testing.html>

Equally important is the testing done by each developer during feature development or changes. For example, on the core development team, developers are charged with executing the entire test suite ( $\geq 230$  files) for their checkins. In addition, one of the core development team does run the entire test suite with each checkin and compares those results to previous results. Unexpected changes, and certainly crashes, should NOT occur.

Since most modules being developed are aimed at the HVAC or plant features, there is a standard 5-zone template geometry that can be used. This should form the basis of any new additions. The old 3-zone model should not be used. Of course, you may develop your own model.

Developers are also charged with making sure their input file runs an entire weather year, has minimal errors (including max simulation errors) and results compare *exactly* when design days (preferably winter-summer vs summer-winter) are reversed in consecutive runs (also known as ReverseDD). To assist in ReverseDD testing, each input file *should* have a “Run Control” object as well as (at least) two design days (winter-summer / summer-winter as the first two).

Input files should report Zone Air temperatures (Zone Mean Air Temperature or Zone/Sys Air Temperature) as well as meters such as electricity and gas (if applicable). Of course, reporting features being implemented should be done as well. These variables will help identify files that have proper “ReverseDD” requirements (failures usually indicate some initialization problems).

Developers should try to minimize output file size – if you are running a full annual simulation (as required by your feature), you should *NOT* report variables at the timestep level.

To compare results, we have a python script (Mathdiff) that is run on the .csv files. It will report (by default) differences  $\leq .001$  or  $\leq .5\%$  as “within range” and outside those limits as “differences”. If they are exactly the same (from the .csv precision limits), they will be reported as such.

Developers in the core development team use several methods for running the entire test suite.

- One method uses a list of input file names along with an indication of the proper weather file. A program reads this file and produces several batch files which help with not only running the file but comparing them to previous results, building the “composite error” (the .err files from each file run), and other utility features. (The same file can be used in Linux testing)
- Another method uses a batch file with options that will allow running old vs. new exes as well as somewhat automating the reverse dd testing.

- Still another method uses a simple batch procedure to “run” all files in a folder.
- Finally, EP-Launch and “groups” can be used.

To facilitate testing, Environment Variables “values” have been implemented in EnergyPlus and/or script files. To use, one uses the “Set” command and the value as indicated. Environment variable value testing is inherent in F2003 compliant compilers; for others we have written a set of routines that can either be modified or used directly.

***DDOnly: Design Days Only***

Setting to “yes” will cause EnergyPlus to set Run Control option (regardless of whether there is a Run Control object in the input file) for Do the Design Day Simulation to “yes” and Do the Weather File Simulation to “no”. (Uses logical variable **DDOnly** in module DataSystemVariables).

```
Set DDOnly=yes
```

***FullAnnualRun: Full Annual simulation***

Setting to “yes” will cause EnergyPlus to set Run Control option (regardless of whether there is a Run Control object in the input file) for Do the Weather File Simulation to “yes”. Scripts should use a weather file when this environment variable is set. (Uses logical variable **FullAnnualRun** in module DataSystemVariables).

```
Set FullAnnualRun=yes
And appropriate changes to script files
```

***NoWeatherFile: Do not use weatherfile even if indicated***

Setting to “yes” doesn’t cause EnergyPlus to do anything but can be used in the scripts to not copy a weather file even when indicated.

```
Set NoWeatherFile=yes
And appropriate changes to script files
```

***ReverseDD: Reverse Design Days during run***

Setting to “yes” causes the first two design days requested in the input file to be reversed during EnergyPlus execution. (Uses logical variable **ReverseDD** in module DataSystemVariables). For proper comparisons to original order, a program such as **ReverseDDInCSV** or **ReverseDDInESO** must be run or hand edited.

```
Set ReverseDD=yes
And appropriate changes to script files
```

***MinReportFrequency: Set minimum reporting frequency for outputs***

Some developers persist in reporting at the timestep or detailed level even if their runs are full annual runs. This is really burdensome on developers that try to run the full test suite for checking changes. The MinReportFrequency environment variable allows EnergyPlus to report at a higher/less frequent level that still allows for changes to be checked (though differences may require more frequent reporting to track down). EnergyPlus reads this environment variable and sets reporting frequency appropriately.

```
Set MinReportFrequency=daily
```



The standard frequencies accepted by EnergyPlus must be used: detail, timestep, hourly, daily, monthly, runperiod, environment, annual. In addition, if this environment variable is used, the following will show in the .eio file:

```
! <Minimum Reporting Frequency (overriding input value)>, Value, Input Value
Minimum Reporting Frequency, !Daily [Value,Min,Hour,Minute,Max,Hour,Minute],DAILY
```

#### ***ReportDuringWarmup: Cause reporting during warmup***

Setting to “yes” causes reporting (Output:Variable, Output:Meter) to be reporting during the warmup days at the start of each environment. (Uses logical variable **ReportDuringWarmup** in module DataSystemVariables).

```
Set ReportDuringWarmup=yes
```

#### ***Caution: Environment Variables***

Some combinations will cause fatal errors from EnergyPlus – **DDOnly** and **FullAnnualRun**, for example. **FullAnnualRun** and **NoWeatherFile** won’t cause fatal errors from EnergyPlus but probably should from the script files. We welcome any suggestions for future environment variables.

## **Air Loop Simulation**

To facilitate comparing the runtime performance of various solution techniques for the air loop simulation a mechanism to track runtime statistics has been implemented in EnergyPlus. To facilitate debugging the air loop simulation a tracing mechanism operating either at the air loop-level or at the controller-level has been implemented in EnergyPlus. To use, one uses the “Set” command and the value as indicated.

#### ***TRACK\_AIRLOOP: Runtime performance tracker for air loop simulation***

Setting to “yes” will cause EnergyPlus to track the performance of the air loop simulation at runtime and dump the results in a file named “statistics.HVACControllers.csv” upon ending the simulation. (Uses logical variable **TrackAirLoopEnvFlag** in module DataSystemVariables).

```
Set TRACK_AIRLOOP=yes
```

#### ***TRACE\_AIRLOOP: Air loop simulation tracer***

Setting to “yes” will cause EnergyPlus to write to a trace file named “controller.<Air Loop Name>.csv” the converged solutions of all controllers defined on each air loop, at each HVAC iteration. (Uses logical variable **TraceAirLoopEnvFlag** in module DataSystemVariables).

```
Set TRACE_AIRLOOP=yes
```

#### ***TRACE\_HVACCONTROLLER: Individual HVAC controller tracer***

Setting to “yes” will cause EnergyPlus to write to a trace file named “controller.<Controller Name>.csv” a detailed description of each controller iteration at each HVAC iteration. (Uses logical variable **TraceControllerEnvFlag** in module DataSystemVariables).

```
Set TRACE_HVACCONTROLLER=yes
```

## Quick Procedure Outline For Making Code Changes to EnergyPlus

Some of the steps in this section are primarily applicable to developers who are part of the “EnergyPlus Team”. However, these steps should also be followed as you develop a module or other piece to submit to the EnergyPlus Team for inclusion in an EnergyPlus release.

1. Write a New Feature Proposal (often called NFP) for discussion at a bi-weekly conference call. Based on that discussion, update the NFP. Out of team developers: use the NFP format to help formulate your submission documentation to the EnergyPlus Team. ***The NFP format is shown in Appendix F.***
2. Get the relevant files for your development. Team developers can check out files from StarTeam.
  - a. Energy+.idd and Featurechanges.csv are in the ‘Release’ Folder. This folder also contains the “Rules” spreadsheet and “Report Variables” files.
  - b. ExampleFiles.xls, ExampleFilesDoc.txt, and baseline or relevant IDF files from ‘Test Files - Utilities\InternalTests\InputFiles’
  - c. F90 files from the ‘SourceCode’ folder.
  - d. Documents (InputOutputReference.doc, EngineeringReference.doc, OutputDetailsAndExamples.doc, etc.) from the ‘External Documentation\Documentation Sources’ folder.
3. Following proper procedures (e.g., *Object naming conventions are specified earlier in this document*) make your object changes to the Energy+.idd and relevant IDF files. If your IDD modifications make changes for existing objects, you must determine if you need to add to the “Rules” spreadsheet so that the transition program can be made for existing IDF files. Likewise, if you change existing report variable names, you must update the “Report Variables” file. Note that the ExampleFiles.xls has some guidance on the contents of new test suite files. Create or change existing IDF files for your feature.
4. Make code changes to F90 files for subroutines, GetInput, Sim, Report or create your own module following the Programming Standards and Programming Templates. Programming Templates are available in Appendix D. Programming Standards is a separate document.
5. Compile and run in debug mode to track errors.
6. Test making sample runs; review summary and time step reports to identify issues. Test many features of your module even if you are not including all in the Test Suite IDF file. Go back to Step 4 as necessary. Note some of the issues in the “Important Rules for Developers”.
7. When complete, run full test suite to make sure there are no crashes or unexpected changes in other files.
8. Run Reverse DD for your featured files – making sure the results *exactly* match.
9. Update relevant portions of documents: InputOutputReference.doc, EngineeringReference.doc, OutputDetailsAndExamples.doc, etc. Only

excerpted portions of the document should be sent forward for review and final inclusion in the whole document. Depending on the changes, it may be better to “track changes” in the document or give instructions for inclusion in the whole document. Send these documents up the review chain as appropriate. **Appendix C also has some information about formatting documents.**

10. Procedure on checking in files changes from time to time. Currently, all source code files are kept locked and your code may go through another review before you are allowed to check in. **Follow procedures in Appendix B as well about submitting your feature – many parts are repeated in this section.**
11. Check in modified or new files. If changes have been made to the original checked out file, you must carefully merge your changes into the file – this also may necessitate you repeating your test runs. Usually, your featurechanges modification will be very simple and be the last line in that file.
12. Send email to the team notifying them of the new feature/changed feature/defect fix and what files were changed/added/etc.
13. Incorporate any feedback after checkin.
14. Use **Appendix G** to submit information, if applicable, about your feature.

## Important Rules for Module Developers

1. INITIALIZE!!!! INITIALIZE either fully or "invalidly" when you ALLOCATE the array/derived type. Two items have been set up to help you: BigNumber and DBigNumber are in DataGlobals. They get initialized before anything happens in the main routine (EnergyPlus). An invalid initialization can use one of these, appropriately (i.e. set and test for "BigNumber"). Another example of "invalid" initialization is a value that shouldn't be legal for the item (-999).
2. Warning errors during "get input" should only be used when program termination is not required (this is rare). Each GetInput routine should be structured so that errors detected (such as an invalid schedule name which currently is just a warning) cause a fatal error after all the input for that item/module/etc is gotten. (See HBManager, BaseboardRadiator, others) In addition, don't make GetInputFlag a module variable. Make it as "local" as possible. Look at BaseboardRadiator for an example.
3. Error messages during simulation should be semi-intelligent. No one wants to see 5,000 messages saying "this flow invalid". If the error condition might happen a lot (especially during debugging), count each occurrence and only put out a message every 50 or so. It is better to use the "Recurring Error Handling" routines. (See examples of both above in the Error Messages section). Also, if you are putting the same message in two modules, identify the error message with some designation. For Example,  
CALL ShowWarningError ('SimRoutineName: this condition happened again')  
will help everyone track it down. Use the ShowContinueErrorTimeStamp so the time/date/environment of occurrence is known, as appropriate for the condition.
4. Use the templates for documentation! Modules, subroutines, functions templates all have been checked into StarTeam. Use them. Put INTENTS on your Subroutine Arguments. Document variables.
5. Add "meter" variables as appropriate! If your module uses fuel or electricity and that energy is not accounted for by other components (i.e. pumps, coils, chillers, etc), then you need to report it onto a "meter".
6. Avoid the use of string comparisons in subroutines other than GetInput. Check string comparisons in the GetInput subroutines and assign an integer parameter for comparisons elsewhere in the module. Character strings in structures are not allowed (except for name of object) – any exceptions must be approved. Schedule names, curve object names, and child object types MUST all be referenced by an integer. Existing code must be changed as you change any of the code within a module.
7. If you are submitting code for insertion in the public version of EnergyPlus, make sure that the proper "Grant-Back" procedure has been followed so that the correct attributions of code authorship are given as well as permission to use this code in publicly available software is assured. (see Appendix G, Code/Module Contribution Questionnaire – also available separately)

## Appendix A. DataGlobals and DataEnvironments Modules

Rather than include the code of the DataGlobals and DataEnvironments modules, they will be described here.

### DataGlobals

DataGlobals contains parameters, variables, Interface descriptors that could be used by every part of the program. For example, this is where the “MaxNameLength” (maximum name length (characters) of objects. All other pieces of the code that need this will need to

```
USE DataGlobals
```

and, if that’s the only piece it needs, can say

```
USE DataGlobals, ONLY: MaxNameLength
```

Interface specifications for the ShowError routines are here because there are optional parameters in these routines. Then,

```
USE DataGlobals, ONLY: ShowWarningError, ShowFatalError
```

can be used safely from any routine. Constants such as Pi ( $\pi$ ), Degrees To Radians, and Number of Seconds in Hour are also stored there. Remember that we suggest compiling EnergyPlus in double precision and these constants (as should all constants) are representative of double precision (even if someone were to compile in single precision).

Finally, the interface specifications for the Setup Report Variables is contained in this module. The interface allows for a single call for accomplishing that while actually forking to call several different routines based on the type of data being used.

### DataEnvironment

DataEnvironment is intended to address global environmental variables (such as current outdoor temperature, barometric pressure, and so forth). It also extends the concept of a “data only” module a bit to encompass a few functions that calculate values for the site atmospheric variation concept.

## Appendix B. Submissions and Check-ins

There are two methods by which new modules are entered into the EnergyPlus (publicly available) program.

- **Checkin:** Part of the core development team may create or modify an existing module. As we use a configuration management system – this is called a check in.

**Note -- to save people grief and rework effort and to work toward consistency in approach, new features or changes to existing features must be proposed in a documented way for discussion during one of the bi-weekly conference calls.**

- **Submission:** When someone outside the core development team submits a module or modification of an existing module for inclusion, this is termed a submission.

**Submissions are subjected to the same kind of scrutiny as team checkins and usually will require rework by the submitter. We welcome outside developers to send their ideas as early documents for comment with the understanding that revising does not guarantee automatic inclusion. See the proposed feature outline document in Appendix F and/or the “doc” file in the Documents for Developers Zip file.**

Both kinds of inclusions need to follow the checklist procedure for new inclusions:

### ✓ Source Code Rules

Shall follow programming standard

Shall follow F90/95 or later standards (use “allocatable” for allocatable structures within Derived Types)

Shall follow the Template standards (documentation, naming conventions)

Shall follow the guidelines shown in this document

All items shall be directly initialized (exception: derived type elements may be statically initialized)

There shall be no “unused” variables. If you put in a variable that you “might use later” – comment it out and comment it to be used later.

No Tabs in source code!!!

Lines shall be less than 133 characters in length. (Some compilers allow longer lines without warning).

Suggest using F95 standards checking during compiles -- you may use the compiler option to generate warnings for non-standard code.

**Permission to use the code shall be supplied -- written, even email, is required. LBNL is monitoring this aspect – so a grant-back letter can also be obtained from them.**

### ✓ Energy+.IDD rules

Standard Units shall be used (SI only on Input)

Show units with the `\units` field. Supply `\ip-units` only if your input would require it (see comments at top of the Energy+.idd).

Use `\minimum` and `\maximum`

The first field following the object name should contain “**name**” as part of the field name

Use `\default`, `\min-fields` and `\required-field` appropriately

Object changes during minor releases (x.x.xxx) should not change fields in the middle – only at the end

Surface objects may not add further fields to the end (the end is reserved for vertices and extension to the current limits)

Note that changes in the Energy+.idd will require a “transition” rule change in the Rules Spreadsheet file (Rules...xls). Likewise, changes in report variable names must be documented in the “report variables” change file that is a companion to the Rules spreadsheet.

✓ **Testing**

Shall run the full test suite for all new features and unless you are absolutely, positively sure that your change will not impact other parts of the code. We have a python script that can compare between two run versions (using the .csv files output from ReadVarsESO).

If you need a script, look under StarTeam...Test Files>ScriptMaker. Other scripts are mentioned in the section on “Running EnergyPlus for Developers” (Module Developer’s Guide).

If you modify objects, you must change **all** test suite files that are impacted by your object modifications.

✓ **New Features need a new example file**

You must create a new input file for your changes—input files shall include appropriate internal documentation! (Test files have a document template as well see Appendix E. Test File Documentation). Some features may be appropriately added to an existing file but documentation must be updated.

You must fill out a line in the “ExampleFiles.xls” spreadsheet for your new input file.

You must run a full annual run with your test file even if that is not the configuration that ends up in the internal test suite. Annual runs have been known to fail – obviously, your input file should not.

You must try to minimize the number of errors shown in the eplusout.err file for your files.

Reverse DD Compliance Test: You must run a test that reverses a run of two environments (design days) and make sure that the results (when you also reverse the results files) are identical. (Identical means *exactly* the same.) Several scripts and automated programs to accomplish this feat are available.

✓ **Documentation (must be included at the same time as code!!!)**

A document template is available for use – only the styles in that document should be used. (Microsoft™ Word is our standard word processing software).

Equations – limited in IORef, necessary in Engineering Doc – limit the number of “references” though. You can use standard Equation formatting from Microsoft™ Word or Mathtype™ is an acceptable alternate.

Figures – Though AutoShapes may draw nice pictures, they are not often “captionable” without undue editing. Please make figures into Jpegs or GIFs. Use “insert caption” (below the figure) so that auto-numbering of figures is used (these will transfer automatically to EnergyPlus documents).

Tables – use “insert caption” (above the table) so that auto-numbering of figures is used (these will transfer automatically to EnergyPlus documents).

Cross-References – limit your “insert cross references”. You should highlight these so that “editing” from your inclusion is more obvious – use a different color to help them stand out.

IORef – See the InputOutputReference document for indications of what is included.

Eng Ref – New modules shall include an engineering document reference. See the Engineering Reference for indications of typical writeups.

Output Details and Examples – this can help illustrate your changes. Any new files *must* be detailed in here. Likewise, changes to the .eio file must be described.

✓ **FeatureChanges.csv**

Every change to source code, example files, datasets, utilities (any change other than documentation) must include a line in the “featurechanges.csv” file.

✓ **Checked in?**

A courtesy message to the EnergyPlus team should be done for each check in, with details of files checked in, etc. Save one of the emails you have received if you don’t know how many to send it to.

✓ **Defect fixing?**

If you fix a defect or “fix” a suggested change (CR), you should mark it “fixed” in StarTeam and the responsibility should automatically change back to the author of the CR. If you fix your own CR, assign it to someone else for verification.

If you fix a defect or “fix” a suggested change, you should provide a “synopsis for users” (on the “Custom” tab in the CR edit dialog) so that when we release the version with your fix, we can provide something descriptive for the users.

If a defect has a workaround, you should enter this in the “Workaround” field (on the “Solution” tab) to inform users until the fix is released in a public version.

✓ **Rules...xls**

If a transition rule will be needed (or a deleted / obsolete / renamed object is needed) – a line (or more) in this spreadsheet must be used. See example rules files from previous releases. If in doubt, put something in.



✓ **ReportVariables...csv**

If you change the name of a report variable, the transition program for release can automatically transition older input files **IF** you put the old and new names into this file.

If you delete a report variable, that detail should go in this file. Note that you must consult others on the core development team before deleting a reported variable.

## Appendix C. Documentation Specifics

Documents that module developers will typically be updating or changing are the: Input Output Reference, Engineering Documentation, and Output Details and Examples. You may, of course, note revisions to other documents.

All of the EnergyPlus documentation follows a Word™ template – report.dot.

This template takes care of many of the nuances of formatting so that the documents all retain the same “look and feel”. The template itself will contain examples for the IORef and Engineering Documentation.

General guidelines:

- Don't get fancy with formatting. No extra “enters” are needed to space the paragraphs.
- Submit your pictures as pictures (jpeg, tif, gif). This will allow you to “insert captions” below them and have them automatically numbered. (This also allows them to be re-numbered once inside the EnergyPlus documents). Don't use Text boxes.
- Likewise, use an “insert caption” on tables.
- Table captions go above the table. Figure captions go below.
- If you want to reference a table or figure in your text, use “insert cross reference” and select table or figure as appropriate. Usually, just use the “label and number” option.
- Body Text is the expected style for most text. DO NOT put object names in a different font (such as Courier) or as a different size though you may bold them for emphasis.
- Headings are used judiciously to help separate text.
- Object names (IOReference) are Heading 3.
- Each field must be described and shown as Heading 4 followed by the description. Form should be “Field: <field Name>”. (Exception: if your object has a repeating set of fields – you may describe the initial field set in detail such as is done for the branch specifications fields in the Branch object).
- Each object's IDD must be shown and use the format “IDD Definition”.
- An excerpt IDF using the object must be shown.
- Output variables for the object must be shown (heading 4) with a heading 3 <object name> Output variables preceding.
- Equations may be inserted using the Microsoft™ Equation Editor. Internally we use software called “MathType” – that also may be used for Equations. It is not desirable to number every equation. If you want to reference the equations, of course, you will need to number them – it is best to number them in plain text and then we can edit them into the rest of the documents.
- Each Engineering Reference section should contain a “References” section and should be formatted in author style (not numbered).

Example References:

- ASHRAE. 1993. 1993 ASHRAE Handbook – Fundamentals. Atlanta: American Society of Heating, Refrigerating, and Air-Conditioning Engineers, Inc.
- Chapman, A. J. 1984. Heat Transfer, 4<sup>th</sup> Edition, New York: Macmillan Publishing Company.
- Lienhard, J. H. 1981. A Heat Transfer Textbook, Englewood Cliffs, N.J.: Prentice-Hall, Inc.
- McClellan, T. M., and C. O. Pedersen. 1997. Investigation of Outside Heat Balance Models for Use in a Heat Balance Cooling Load Calculation. ASHRAE Transactions, Vol. 103, Part 2, pp. 469-484.
- Walton, G. N. 1983. Thermal Analysis Research Program Reference Manual. NBSSIR 83-2655. National Bureau of Standards.

## Appendix D. Module, Subroutine, Function Templates

The following module template can and should be used to create new modules. Following the module template are subroutine and function templates. You should be able to copy the template for your own use (or you can get a plain text version).

```
MODULE <module_name>

    ! Module containing the routines dealing with the <module_name>

    ! MODULE INFORMATION:
    !     AUTHOR          <author>
    !     DATE WRITTEN    <date_written>
    !     MODIFIED        na
    !     RE-ENGINEERED   na

    ! PURPOSE OF THIS MODULE:
    ! <description>

    ! METHODOLOGY EMPLOYED:
    ! <description>

    ! REFERENCES:
    ! na

    ! OTHER NOTES:
    ! na

    ! USE STATEMENTS:
    ! <use statements for data only modules>
USE DataGlobals, ONLY: ShowWarningError, ShowSevereError, ShowFatalError, &
    MaxNameLength, ...

    ! <use statements for access to subroutines in other modules>

IMPLICIT NONE ! Enforce explicit typing of all variables

PRIVATE ! Everything private unless explicitly made public

    ! MODULE PARAMETER DEFINITIONS:
    ! na

    ! DERIVED TYPE DEFINITIONS:
    ! na

    ! MODULE VARIABLE DECLARATIONS:
    ! na
```

```

! SUBROUTINE SPECIFICATIONS FOR MODULE:
! Driver/Manager Routines
PUBLIC Sim<module_name>

! Get Input routines for module
PRIVATE Get<module_name>

! Initialization routines for module
PRIVATE Init<module_name>
PRIVATE Size<module_name>

! Algorithms/Calculation routines for the module
PRIVATE Calc<module_name>

! Update routines to check convergence and update nodes
PRIVATE Update<module_name>

! Reporting routines for module
PRIVATE Report<module_name>

! Utility routines for module
! these would be public such as:
! PUBLIC Get<module>InletNode
! PUBLIC Get<module>OutletNode

CONTAINS

SUBROUTINE Sim<module_name>

! SUBROUTINE INFORMATION:
!   AUTHOR      <author>
!   DATE WRITTEN <date_written>
!   MODIFIED    na
!   RE-ENGINEERED na

! PURPOSE OF THIS SUBROUTINE:
! <description>

! METHODOLOGY EMPLOYED:
! <description>

! REFERENCES:
! na

! USE STATEMENTS:
! na

IMPLICIT NONE ! Enforce explicit typing of all variables in this routine

! SUBROUTINE ARGUMENT DEFINITIONS:
! na

! SUBROUTINE PARAMETER DEFINITIONS:
! na

! INTERFACE BLOCK SPECIFICATIONS:
! na

! DERIVED TYPE DEFINITIONS:
! na

! SUBROUTINE LOCAL VARIABLE DECLARATIONS:
LOGICAL,SAVE      :: GetInputFlag = .true. ! First time, input is "gotten"

IF (GetInputFlag) THEN
  CALL Get<module_name>Input
  GetInputFlag=.false.
ENDIF

<... insert any necessary code here>

```

```

CALL Init<module_name>(Args)

CALL Calc<module_name>(Args)

CALL Update<module_name>(Args)

CALL Report<module_name>(Args)

RETURN

END SUBROUTINE Sim<module_name>

SUBROUTINE Get<module_name>Input

    ! SUBROUTINE INFORMATION:
    !   AUTHOR           <author>
    !   DATE WRITTEN    <date_written>
    !   MODIFIED        na
    !   RE-ENGINEERED  na

    ! PURPOSE OF THIS SUBROUTINE:
    ! <description>

    ! METHODOLOGY EMPLOYED:
    ! <description>

    ! REFERENCES:
    ! na

    ! USE STATEMENTS:
    USE InputProcessor, ONLY: GetNumObjectsFound, GetObjectItem ! might also use FindItemInList
    USE DataIPShortCuts

    IMPLICIT NONE ! Enforce explicit typing of all variables in this routine

    ! SUBROUTINE ARGUMENT DEFINITIONS:
    ! na

    ! SUBROUTINE PARAMETER DEFINITIONS:
    CHARACTER(len=*) , PARAMETER :: RoutineName='PutRoutineNameHere'
    CHARACTER(len=*) , PARAMETER :: CurrentModuleObject='GetModuleObject'

    ! INTERFACE BLOCK SPECIFICATIONS:
    ! na

    ! DERIVED TYPE DEFINITIONS:
    ! na

    ! SUBROUTINE LOCAL VARIABLE DECLARATIONS:
    INTEGER                :: Item      ! Item to be "gotten"
    ! Instead of below, use Variables in IPShortCuts
    ! CHARACTER(len=MaxNameLength), &
    ! DIMENSION(x) :: Alphas ! Alpha items for object
    ! REAL, DIMENSION(y) :: Numbers ! Numeric items for object
    INTEGER                :: NumAlphas ! Number of Alphas for each GetObjectItem call
    INTEGER                :: NumNumbers ! Number of Numbers for each GetObjectItem call
    INTEGER                :: IOStatus  ! Used in GetObjectItem
    LOGICAL                :: ErrorsFound=.false. ! Set to true if errors in input, fatal
at end of routine

<NumItems>=GetNumObjectsFound(CurrentModuleObject)
DO Item=1,<NumItems>
  CALL GetObjectItem(CurrentModuleObject,Item,cAlphaArgs,NumAlphas, &
                    rNumericArgs,NumNumbers,IOStatus, &
                    AlphaBlank=lAlphaFieldBlanks,NumBlank=lNumericFieldBlanks, &
                    AlphaFieldNames=cAlphaFieldNames,NumericFieldNames=cNumericFieldNames)
  <process, noting errors>
  ! Errors should be formatted as (alpha 1 should hold the name of the object)
  CALL ShowSevereError(RoutineName//':'//CurrentModuleObject//'='//trim(cAlphaArgs(1))// &
    '"', invalid '//trim(cAlphaFieldNames(x))//'='//trim(cAlphaArgs(x))//'" <condition>.')
  ! likewise for numeric fields

```

```

ENDDO

<SetupOutputVariables here...>

IF (ErrorsFound) THEN
  CALL ShowFatalError(RoutineName//'://'CurrentModuleObject//': Errors found in input.')
ENDIF

RETURN

```

```
END SUBROUTINE Get<module_name>Input
```

```
SUBROUTINE Init<module_name>
```

```

! SUBROUTINE INFORMATION:
!   AUTHOR           <author>
!   DATE WRITTEN    <date_written>
!   MODIFIED        na
!   RE-ENGINEERED   na

```

```

! PURPOSE OF THIS SUBROUTINE:
! <description>

```

```

! METHODOLOGY EMPLOYED:
! <description>

```

```

! REFERENCES:
! na

```

```

! USE STATEMENTS:
! na

```

```
IMPLICIT NONE      ! Enforce explicit typing of all variables in this routine
```

```

! SUBROUTINE ARGUMENT DEFINITIONS:
! na

```

```

! SUBROUTINE PARAMETER DEFINITIONS:
! na

```

```

! INTERFACE BLOCK SPECIFICATIONS
! na

```

```

! DERIVED TYPE DEFINITIONS
! na

```

```

! SUBROUTINE LOCAL VARIABLE DECLARATIONS:
! na

```

```
RETURN
```

```
END SUBROUTINE Init<module_name>
```

```
SUBROUTINE Size<module_name>
```

```

! SUBROUTINE INFORMATION:
!   AUTHOR           <author>
!   DATE WRITTEN    <date_written>
!   MODIFIED        na
!   RE-ENGINEERED   na

```

```

! PURPOSE OF THIS SUBROUTINE:
! <description>

```

```

! METHODOLOGY EMPLOYED:
! <description>

```

```

! REFERENCES:
! na

```

```
! USE STATEMENTS:
! na

IMPLICIT NONE ! Enforce explicit typing of all variables in this routine

! SUBROUTINE ARGUMENT DEFINITIONS:
! na

! SUBROUTINE PARAMETER DEFINITIONS:
! na

! INTERFACE BLOCK SPECIFICATIONS
! na

! DERIVED TYPE DEFINITIONS
! na

! SUBROUTINE LOCAL VARIABLE DECLARATIONS:
! na

RETURN

END SUBROUTINE Size<module_name>

SUBROUTINE Calc<module_name>

! SUBROUTINE INFORMATION:
!   AUTHOR          <author>
!   DATE WRITTEN    <date_written>
!   MODIFIED        na
!   RE-ENGINEERED   na

! PURPOSE OF THIS SUBROUTINE:
! <description>

! METHODOLOGY EMPLOYED:
! <description>

! REFERENCES:
! na

! USE STATEMENTS:
! na

IMPLICIT NONE ! Enforce explicit typing of all variables in this routine

! SUBROUTINE ARGUMENT DEFINITIONS:
! na

! SUBROUTINE PARAMETER DEFINITIONS:
! na

! INTERFACE BLOCK SPECIFICATIONS:
! na

! DERIVED TYPE DEFINITIONS:
! na

! SUBROUTINE LOCAL VARIABLE DECLARATIONS:
! na

RETURN

END SUBROUTINE Calc<module_name>

SUBROUTINE Update<module_name>

! SUBROUTINE INFORMATION:
!   AUTHOR          <author>
!   DATE WRITTEN    <date_written>
!   MODIFIED        na
```



```
! RE-ENGINEERED na

! PURPOSE OF THIS SUBROUTINE:
! <description>

! METHODOLOGY EMPLOYED:
! <description>

! REFERENCES:
! na

! USE STATEMENTS:
! na

IMPLICIT NONE ! Enforce explicit typing of all variables in this routine

! SUBROUTINE ARGUMENT DEFINITIONS:
! na

! SUBROUTINE PARAMETER DEFINITIONS:
! na

! INTERFACE BLOCK SPECIFICATIONS:
! na

! DERIVED TYPE DEFINITIONS:
! na

! SUBROUTINE LOCAL VARIABLE DECLARATIONS:
! na

RETURN

END SUBROUTINE Update<module_name>

SUBROUTINE Report<module_name>

! SUBROUTINE INFORMATION:
! AUTHOR <author>
! DATE WRITTEN <date_written>
! MODIFIED na
! RE-ENGINEERED na

! PURPOSE OF THIS SUBROUTINE:
! <description>

! METHODOLOGY EMPLOYED:
! <description>

! REFERENCES:
! na

! USE STATEMENTS:
! na

IMPLICIT NONE ! Enforce explicit typing of all variables in this routine

! SUBROUTINE ARGUMENT DEFINITIONS:
! na

! SUBROUTINE PARAMETER DEFINITIONS:
! na

! INTERFACE BLOCK SPECIFICATIONS:
! na

! DERIVED TYPE DEFINITIONS:
! na

! SUBROUTINE LOCAL VARIABLE DECLARATIONS:
! na
```

```

! <this routine is typically needed only for those cases where you must transform the internal
data to a reportable form>

RETURN

END SUBROUTINE Report<module_name>

!===== Utility/Other routines for module.
! Insert as appropriate
! Insert Standard Copyright Notice here.

END MODULE <module_name>

```

### The Subroutine Template:

```

SUBROUTINE <name>

! SUBROUTINE INFORMATION:
!   AUTHOR           <author>
!   DATE WRITTEN    <date_written>
!   MODIFIED        na
!   RE-ENGINEERED   na

! PURPOSE OF THIS SUBROUTINE:
! This subroutine needs a description.

! METHODOLOGY EMPLOYED:
! Needs description, as appropriate.

! REFERENCES:
! na

! USE STATEMENTS:
! na

```

```

IMPLICIT NONE      ! Enforce explicit typing of all variables in this routine

! SUBROUTINE ARGUMENT DEFINITIONS:
! na

! SUBROUTINE PARAMETER DEFINITIONS:
! na

! INTERFACE BLOCK SPECIFICATIONS
! na

! DERIVED TYPE DEFINITIONS
! na

! SUBROUTINE LOCAL VARIABLE DECLARATIONS:
! na

RETURN

END SUBROUTINE <name>

```

### And the Function Template:

```
<type> FUNCTION <name>

    ! FUNCTION INFORMATION:
    !   AUTHOR          <author>
    !   DATE WRITTEN   <date_written>
    !   MODIFIED       na
    !   RE-ENGINEERED  na

    ! PURPOSE OF THIS FUNCTION:
    ! This function needs a description.

    ! METHODOLOGY EMPLOYED:
    ! Needs description, as appropriate.

    ! REFERENCES:
    ! na

    ! USE STATEMENTS:
    ! na

IMPLICIT NONE      ! Enforce explicit typing of all variables in this routine

    ! FUNCTION ARGUMENT DEFINITIONS:
    ! na

    ! FUNCTION PARAMETER DEFINITIONS:
    ! na

    ! INTERFACE BLOCK SPECIFICATIONS
    ! na

    ! DERIVED TYPE DEFINITIONS
    ! na

    ! FUNCTION LOCAL VARIABLE DECLARATIONS:
    ! na

RETURN

END FUNCTION <name>
```

## Appendix E. Test File Documentation

Each test file, whether released to the public or not, should be a best practice model and documented (comments at the top of the file) following the guidelines below. The document template file is also included with each installation in the “ExampleFiles” folder – ExampleFilesDoc.txt

```
! <name of file>
! Basic file description: <specify number of zones, stories in building, etc>
! Highlights: <Purpose of this example file>
! Simulation Location/Run: <location information, design days, run periods>
! Location:
! Design Days (should have SummerDesignDay,WinterDesignDay designations):
! Run Period (Weather File):
! Run Control (should include this):
!
! Building: <more details about building.  metric units, if also english enclose in []{} or ()>
! Floor Area:
! Number of Stories:
!
! Zone Description Details:
! Internal gains description: <lighting level, equipment, number of occupants, infiltration,
daylighting, etc>
! Interzone Surfaces:
! Internal Mass:
! People:
! Lights:
! Windows:
! Detached Shading:
! Daylight:
! Natural Ventilation      :
! Compact Schedules (preferred):
! Solar Distribution:
!
! HVAC: <HVAC description and plant supply, as appropriate>
! Purchased Air:
! Zonal Equipment:
! Central Air Handling Equipment:
! System Equipment Autosize:
! Purchased Cooling:
! Purchased Heating:
! Coils:
! Pumps:
! Boilers:
! Chillers:
! Towers:
!
! Results: <how are results reported>
! Standard Reports:
! Timestep or Hourly Variables:
! Time bins Report:
! HTML Report:
! Environmental Emissions:
! Utility Tariffs:
```

Most of the example files have completed their documentation requirements and include plan views of the building. Our naming convention uses an underscore (\_) as the first character of an input file “not for publication”.

## Appendix F. New or Changed Proposal Feature Template

<TITLE>

<organization>

<Date(s), Original, Revision, etc>

**Justification for Feature Update:**

<Required>

**Conference Call Conclusions:**

<Optional – note date of conference call where talked about>

**Other Conference Call Topics (not in scope of current proposal):**

<Optional>

**Overview:**

<Include Description of Feature and references>

**Approach:**

**Testing/Validation/Data Source(s):**

<required>

**IO Ref (draft):**

<required>

**IDD Object (New):**

<include as appropriate>

**IDD Object(s) (Revised):**

<include as appropriate>

**Proposed Report Variables:**

**Proposed additions to Meters:**

**EngRef (draft):**

<required>

**Example File and Transition changes:**

As needed.

**Other documents:**

As needed.

## Appendix G. Questionnaire for Code Contributions



### ENERGYPLUS™ QUESTIONNAIRE FOR CODE CONTRIBUTIONS

The EnergyPlus™ building energy simulation computer program has been developed jointly by the University of Illinois at Urbana-Champaign and Lawrence Berkeley National Laboratory (Berkeley Lab) under funding from the U.S. Department of Energy. Berkeley Lab has the sole authority to administer the licensing of EnergyPlus™ software.

To ensure the long-term viability of EnergyPlus, any proposed contributions must be made with “no strings attached” – that is, at a minimum, with royalty-free, non-exclusive, unlimited rights for Berkeley Lab to use, copy, modify, prepare derivative works, and distribute any contributions (both source code and executables), and to permit others to do so. Exceptions to this policy are made only in extraordinary circumstances, on a case-by-case basis, and only by Berkeley Lab’s Technology Transfer Dept.

This Questionnaire is intended to aid in our management of contributions to the EnergyPlus code base and to flag any intellectual property or licensing issues that may need to be resolved. EnergyPlus is a team effort! We appreciate your cooperation!

**THIS FORM MUST BE FILLED OUT COMPLETELY FOR US TO CONSIDER YOUR CONTRIBUTION – THANKS!**

Company/Institution (“Contributor”): \_\_\_\_\_

Name of responsible Contributor employee: \_\_\_\_\_

Title or position: \_\_\_\_\_

Department (if applicable): \_\_\_\_\_

Address: \_\_\_\_\_

City / State / Postal Code / Country: \_\_\_\_\_

Tel: \_\_\_\_\_ Fax: \_\_\_\_\_

E-Mail: \_\_\_\_\_ Web: http://\_\_\_\_\_

Who is your contact on the EnergyPlus Development Team? (or “None”) \_\_\_\_\_

I have attached a brief description of my contribution (subroutine(s), module(s), library/ies, etc.). (THIS IS REQUIRED)

Yes  No  Don’t Know -- Do you have an active E+ Collaborative Developer License Agreement in place?

If ‘yes’, is your contribution a user interface?  Yes  No

#### **A. AUTHORSHIP**

1. For the code you are submitting, did you or your fellow employees write every line of code? Before answering “yes,” you should actually contact your fellow employees to confirm that they did not use any code written by others, (e.g., “public domain code,” “open source code,” etc.).

Yes  No (If you don’t know, then find out.)

2. For the code you are submitting, was any written by a contractor or consultant?

Yes  No (If you don’t know, then find out.)  Not applicable (i.e., I answered ‘yes’ to question #1)

2(a) Have you confirmed that the funding/contract document with such contractor/consultant grants you or your institution the necessary rights to provide a royalty-free unlimited license to your contributions to Lawrence Berkeley National Laboratory? (Note: if you are in an academic/research institution, you should confirm this with your contracts & grants office or your technology transfer office). If the answer is “No,” then such rights must be secured in writing before we can consider such code for incorporation into EnergyPlus.

Yes  No (If you don’t know, then find out.)

2(b) Did the contractors/consultants include any code that they did not *actually write themselves*? Before answering “yes,” you should confirm with them that they did not use any code written by others (e.g., “public domain code,” “open source code,” etc.).  
 Yes  No (If you don’t know, then find out.)

3. For ANY code that was not actually written by you, your fellow employees or a contractor/consultant, do you know the portions of the code written by others (i.e., the name of the subroutine, module, library, etc.)?  
 Yes  No  Don’t know  Not applicable (no third party code included)

If “yes,” please list all third party code here (if more than two pieces of third party code, attach separate sheets for each):

Name of Third Party Code #1: \_\_\_\_\_

Copyright notice  None  Printed out and attached

Written license agreement covering the code  None  Printed out and attached

If there is no written license agreement covering the code, then please attach on a separate sheet, any helpful background and contact information to aid in tracking down a proper written license agreement. Also, please note, that with rare exception, code that people consider to be “in the public domain” is almost never actually legally in the public domain.

Name of Third Party Code #2: \_\_\_\_\_

Copyright notice  None  Printed out and attached

Written license agreement covering the code  None  Printed out and attached

If there is no written license agreement covering the code, then please attach on a separate sheet, any helpful background and contact information to aid in tracking down a proper written license agreement.

**B. FUNDING**

1. For the code you are submitting, was your contribution funded under a Berkeley Lab R&D Subcontract?  
 Yes  No  Don’t know

2. For other funding sources, have you confirmed that the funding document (if any) grants you or your institution the necessary rights to provide a royalty-free unlimited license to your contributions to Lawrence Berkeley National Laboratory? (Note: for employees of academic or research institutions, you should confirm this with your contracts & grants office or your technology transfer office). If the answer is “No,” then you do not have the necessary rights to such code and we cannot accept such code for consideration of incorporation into EnergyPlus.  
 Yes  No  I funded this myself  I don’t know the funding source

---

To the best of my knowledge, all of the above is complete and correct. If there are any extenuating or exceptional circumstances regarding any of the above, I have attached a sheet to this form explaining same.

Signed: \_\_\_\_\_

Printed Name: \_\_\_\_\_

Date: \_\_\_\_\_

Please submit the completed **and signed** form via FAX or, if scanned, via e-mail to **BOTH**:

Linda Lawrie  
Fax: (425) 491-0472  
E-Mail: [Linda@FortLawrie.com](mailto:Linda@FortLawrie.com)

Pamela Seidenman, Technology Transfer Dept., Berkeley Lab  
Fax: 510-486-6457  
E-Mail: [psseidenman@lbl.gov](mailto:psseidenman@lbl.gov)

*Thank you very much for your cooperation from the EnergyPlus Team!*