

Packaging for Mailing — Contents

Publication 2, January 2002

TRANSMITTAL LETTER

CONTENTS

1. PACKAGING ADEQUACY
2. CONTAINERS
3. CUSHIONING
4. CLOSING, SEALING, AND REINFORCING

5. MARKING

6. BULK MAIL CENTER STANDARDS

7. HAZARDOUS MATERIALS

APPENDIXES

A — PACKAGE TESTING

B — RATES AND CLASSIFICATION SERVICE CENTERS (RCSCs)



Packaging for Mailing

Publication 2

January 2002
Transmittal Letter

- A. Explanation.** This publication supplements the standards in *Domestic Mail Manual (DMM) C010*. It provides mailers and postal personnel with information on how to properly package items for mailing. Proper packaging prior to mailing is necessary to prevent deterioration and degradation of a mailpiece and its contents.
- B. Distribution and Requisition.** Additional copies can be ordered as follows:
- **Public.** Call the Material Distribution Center (MDC) at 800-332-0317 (option 4). This publication is also available on the Internet at <http://www.usps.com> — click on *Info*, then *Postal Periodicals and Publications*, then *Publications* (either *PDF Format* or *Text Format*), and then *Pub 2*.
 - **Postal Service.** Order by telephone, cc:Mail, or official mail as follows:
 - **Touch Tone Order Entry:** Call 800-332-0317, option 1, then option 2.
 - **cc:Mail:** Send an F3Fill-completed PS Form 7380, *MDC Supply Requisition*, by cc:Mail to MDC Customer Service at TOKS001L.
 - **Official Mail:** Send a completed PS Form 7380, *MDC Supply Requisition*, to the following address:

SUPPLY REQUISITIONS
500 SW GARY ORMSBY DR
TOPEKA KS 66624-9702
- This publication is also available on the corporate intranet at <http://blue.usps.gov> — click on *Information*, then *Policies and Procedures*, then *Pubs*, and then the title of the publication.
- C. Comments and Questions.** Direct comments or questions concerning the content of this publication to the following address:
- MANAGER
MAIL PREPARATION AND STANDARDS
US POSTAL SERVICE
1735 N LYNN ST RM 3025
ARLINGTON VA 22209-6038
- D. Effective Date.** This handbook is effective January 2002.

A handwritten signature in black ink that reads "Stephen M. Kearney".

Stephen M. Kearney
Vice President
Pricing and Classification

Contents

1	Packaging Adequacy	1
1-1	Preparation Requirements	1
1-2	Packaging Evaluation	1
1-3	Load Types	2
1-3.1	Easy Loads	2
1-3.2	Average Loads	2
1-3.3	Difficult Loads	2
1-4	Acceptability	3
1-4.1	General	3
1-4.2	Stationery	3
1-4.3	Liquids	3
1-4.4	Aerosols	4
1-4.5	High-Density Loads	4
1-5	Test Packages	4
1-6	Safety	5
1-7	Mailability Determination	5
1-8	Regulation Changes	5
2	Containers	7
2-1	General	7
2-2	Bags, Bales, Bundles, Films, and Wraps	7
2-2.1	Use	7
2-2.2	Paper Bags and Wraps	7
2-2.3	Plastic Bags and Films	8
2-2.4	Cloth Bags	8
2-2.5	Bales and Bundles	8
2-3	Boxes	8
2-3.1	Use and Type	8
2-3.2	Size	9
2-3.3	Making Boxes	10
2-3.4	Banding	10
2-3.5	Outer Wrapping	10
2-4	Cans and Drums	11
2-5	Envelopes	11
2-5.1	Use	11
2-5.2	Letter-Style Envelopes	11
2-5.3	Other Envelope Styles	11
2-5.4	Odd-Shaped Items	12
2-6	Tubes	12

3	Cushioning	13
3-1	Purpose and Method	13
3-2	Materials	13
3-3	Fill Level	13
3-4	Several and Fragile Items	14
4	Closing, Sealing, and Reinforcing	15
4-1	General	15
4-2	Adhesives	15
4-2.1	General	15
4-2.2	Box Flaps	15
4-3	Bandings	16
4-4	Staples and Steel Stitching	16
4-5	Tapes	17
4-5.1	Use	17
4-5.2	Pressure-Sensitive Tape	17
4-5.3	Gummed Tape	18
5	Marking	19
5-1	Authorized Markings	19
5-1.1	General	19
5-1.2	Address	19
5-1.3	Address Correction and Forwarding	20
5-1.4	Class of Mail	20
5-1.5	Special Services	20
5-1.6	Handling Instructions	21
5-2	Unauthorized Markings	21
5-2.1	Obsolete Markings	21
5-2.2	Erroneous Markings	21
5-2.3	Extraneous Markings	21
5-2.4	Other Markings	22
5-3	Marking Methods and Surfaces	22
5-3.1	Marking Methods	22
5-3.2	Surfaces	22
6	Bulk Mail Center Standards	23
6-1	About This Chapter	23
6-2	Books	23
6-2.1	General	23
6-2.2	Books up to 5 Pounds	24
6-2.3	Books From 5 to 10 Pounds	24

Contents

6-2.4	Books From 10 to 25 Pounds	25
6-2.5	Books From 25 to 50 Pounds	25
6-2.6	Books From 50 to 70 Pounds	25
6-3	High-Density Items	26
6-3.1	General	26
6-3.2	High-Density Items up to 20 Pounds	26
6-3.3	High-Density Items From 20 to 45 Pounds	27
6-3.4	High-Density Items From 45 to 70 Pounds	27
6-4	Soft Goods	28
6-4.1	General	28
6-4.2	Soft Goods up to 5 Pounds	28
6-4.3	Soft Goods From 5 to 10 Pounds	28
6-4.4	Soft Goods From 10 to 20 Pounds	29
6-4.5	Soft Goods From 20 to 45 Pounds	29
6-4.6	Soft Goods From 45 to 70 Pounds	29
6-5	Sound Recordings	30
6-5.1	General	30
6-5.2	Sound Recordings up to 10 Pounds	30
6-5.3	Sound Recordings From 10 to 20 Pounds	30
6-5.4	Sound Recordings From 20 to 40 Pounds	31
6-5.5	Sound Recordings From 40 to 70 Pounds	31
6-6	Magnetic Tapes	31
6-6.1	General	31
6-6.2	Magnetic Tapes up to 5 Pounds	31
6-6.3	Magnetic Tapes From 5 to 10 Pounds	32
6-6.4	Magnetic Tapes From 10 to 20 Pounds	32
6-6.5	Magnetic Tapes From 20 to 40 Pounds	32
6-6.6	Magnetic Tapes From 40 to 70 Pounds	33
7	Hazardous Materials	35
7-1	General	35
7-1.1	Definition	35
7-1.2	Federal Laws	35
7-2	Mailing Conditions	35
7-2.1	Postal Regulations	35
7-2.2	Mailability Rulings	36
7-2.3	Packaging	36

Appendixes

A	Package Testing	37
B	Rates and Classification Service Centers (RCSCs)	55

1 Packaging Adequacy

1-1 Preparation Requirements

The information in this publication is primarily for companies and customers who mail parcels and special items. For parcels to be accepted for mailing, they must be prepared according to the requirements and guidelines in this publication. More detailed packaging and mailability requirements are in module C of the *Domestic Mail Manual* (DMM) and in the *International Mail Manual* (IMM). Requirements specific to each class of mail are covered in those manuals.

State and federal regulations also can affect the mailability of parcels containing certain items such as hazardous, biological, and restricted materials. The Postal Service accepts properly prepared and marked parcels, but it reserves the right to refuse parcels that contain nonmailable items or that seem improperly prepared.

1-2 Packaging Evaluation

Items sent through the mail must be packed in a way that prevents their deterioration or degradation. Large-volume mailers should test before shipping to determine their packaging's effectiveness and the product's durability.

Mailers can use the International Safe Transit Association (ISTA) Test Procedure 1A to evaluate their packaging (see Appendix A). Mailers can also contact the nearest postmaster, account representative, or business mail entry manager for a review of their packaging.

1-3 Load Types

In the transportation industry, the term *load* is defined as a quantity of material assembled and packed as a shipping unit. Generally, packages are classified into three load types based on the nature of the contents, how well the packaging protects it, and the strength of the mailing container.

1-3.1 Easy Loads

Easy loads include moderate-density items that can completely fill the mailing container or be packed in interior receptacles. Easy loads are not readily damaged by shock, compression, or puncture during handling or mail processing. They do not shift or move within the container, and they usually do not endanger other parcels.

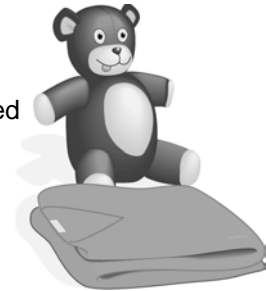

1-3.2 Average Loads

Average loads include moderately concentrated items that usually provide partial support to all surfaces of the mailing container. Often, the item can be damaged if the package is compressed.

Average loads can be placed directly into a container or into separate interior containers. Nesting items within partitions or separate paperboard boxes can stabilize an average load and prevent damage to the container and the items.

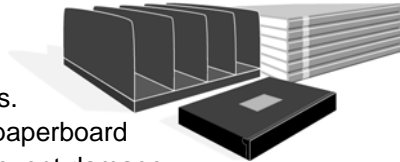

1-3.3 Difficult Loads

The items in difficult loads usually need additional protection against shock, puncture, or distortion during handling or mail processing. Fragile objects, delicate instruments, high-density items, and small bulk items are considered difficult loads. Paper boxes, paper or plastic bags, or wraps of any kind cannot support difficult loads and are not acceptable containers for such items.



1-4 Acceptability

1-4.1 General

Besides load type, packaging acceptability is one of the principal standards of mailability. A container must not be packed in a way that might cause or allow its contents to injure Postal Service employees or to damage other mail or mail processing equipment. Fragile items must be packed to withstand mail processing and transportation. Heavy items must be braced and cushioned to prevent damage to other mail.

Items described in 1-4.2 through 1-4.5 often cause problems when improperly packaged. Requests for exceptions to the requirements in this section must be made to a rates and classification service center (RCSC) (see Appendix B for addresses).

1-4.2 Stationery

Stationery items often become loose during mail processing. Problems are caused by unrestrained, concentrated, or shifting contents and by inadequate internal packaging, containers, closures, and reinforcements.

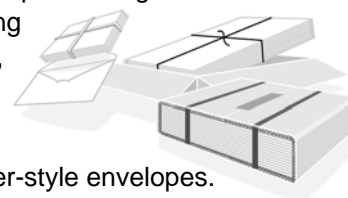

Stationery items that are thicker than 1 inch or heavier than 1 pound may not be mailed in letter-style envelopes. These items must be unitized by tying or banding them or by partitioning tight containers to prevent shifting.

1-4.3 Liquids

1-4.3.1 Containers

Liquids can damage or destroy other mail and mail processing equipment. Generally, containers of liquid with only friction-top closures (push-down type) are not acceptable. Screw-on caps, soldered tops, clips, or other means are necessary for secure closing.



Glass and other breakable containers holding more than 4 fluid ounces must be cushioned with a material that can readily absorb any leakage. These primary containers must be placed and packed inside sealed, leak-proof containers. If a container holds more than 32 fluid ounces, it is not acceptable for mailing unless cushioned as described above and packed within another sealed, leak-proof container such as a can or plastic bag. The outer mailing container must be strong enough to protect the contents, must be marked "LIQUID," and should display orientation markings (i.e., up arrows) that indicate the upright position of the parcel.

1-4.3.2 Exceptions

Steel pails and drums with carrying handles and positive closures (such as locking rings or recessed spouts under screw-cap tops) are acceptable for mailing without additional packing. Requests for exceptions to these requirements must be made to the nearest RCSC (see Appendix B for addresses).

1-4.4 Aerosols

Aerosol containers with inadequate friction-cap closures or other nonpositive means to prevent accidental discharge of contents can injure Postal Service employees or damage other mail and mail processing equipment. These containers must be constructed to prevent accidental discharge of their contents in the mail.

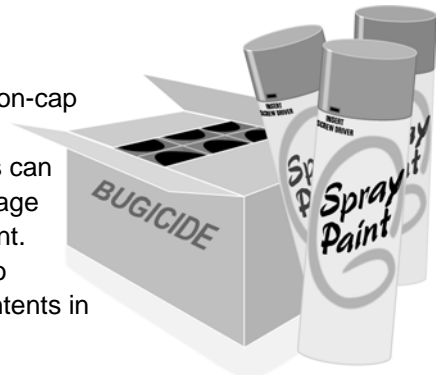

Recessed valves, screw-thread caps, tape closures, or other secure closures can make such containers acceptable.

1-4.5 High-Density Loads

High-density loads (such as tools and machine parts) can be dangerous to Postal Service employees and to other mail and mail processing equipment. High-density loads that weigh between 15 and 35 pounds are machinable on Postal Service mail processing equipment if the loads are packaged so that they do not exert more than 60 pounds of pressure per square foot (0.4167 pound per square inch) on the smallest side of the mailing container.

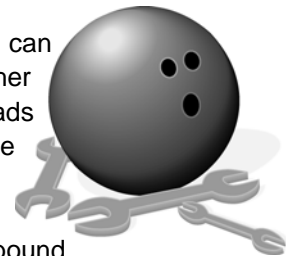

1-5 Test Packages

Packaging that does not meet the minimum requirements in this publication may be permitted under a “test” status. The manager at the originating bulk mail center (BMC) is authorized to approve this test status. Contact the local postmaster for the address of the nearest BMC.

If the BMC manager approves the test packaging and the packaging achieves acceptable performance levels, the mailer may continue using the packaging. If the BMC manager disapproves test status, the mailer may appeal this decision with an RCSC (see Appendix B for addresses).

If a mailer asks to use packaging that deviates significantly from postal requirements, the manager of Mail Preparation and Standards at Postal Service Headquarters must be notified. If the deviation cannot be resolved by the accepting postmaster, the BMC manager, or the business mail entry manager, the mailer's request is referred to the rates and classification service center.

1-6 Safety

Mailers should take appropriate precautions when packaging a parcel of mailable items that have the potential to injure any person handling or opening the parcel. Because a small child might gain unauthorized access to a parcel, every potentially harmful item should be enclosed in a container that is hard for a child to open.

1-7 Mailability Determination

If a mailer is unsure about whether an item is mailable or its packaging is acceptable, the mailer should send a written request to the nearest business mail entry unit (see DMM G042 for addresses). To ask for an exception to Postal Service packaging requirements, the mailer should submit a written request to an RCSC (see Appendix B for addresses). The request should fully describe the item and its packaging.

1-8 Regulation Changes

Postal regulations change from time to time. If there is conflicting information between this publication and the DMM or IMM, then the DMM or IMM takes precedence. Mailers may review copies of these documents at any post office, business mail entry unit, or postal business center. Both documents are available to the public through a subscription service handled by the U.S. Government Printing Office, and current versions are accessible on the Postal Service's "Postal Explorer" web page at <http://pe.usps.gov>.

This page intentionally left blank

2 Containers

2-1 General

Several types of containers are acceptable for mailing items if the containers and items are prepared within the standards of this publication. The principal types of mailing containers include the following:

- Bags, bales, bundles, films, and wraps.
- Boxes.
- Cans and drums.
- Envelopes.
- Tubes.

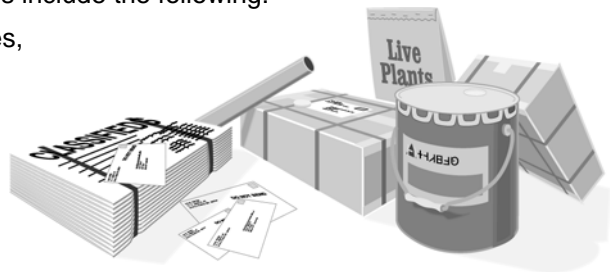

2-2 Bags, Bales, Bundles, Films, and Wraps

2-2.1 Use

Bags, bales, bundles, films, and wraps are acceptable for mailing certain easy loads and average loads. The contents in these containers should be compressed when possible. The Postal Service does not accept such containers for the mailing of difficult loads.

2-2.2 Paper Bags and Wraps

2-2.2.1 Easy Load up to 5 Pounds

A paper bag or paper wrap is acceptable. The paper must be of at least 50-pound basis weight — the strength of a regular large grocery sack. The contents must be immune from impact or pressure damage. The combining (layering) of several sheets that add up to or exceed a 50-pound basis weight is not acceptable.

2-2.2.2 Easy or Average Load up to 20 Pounds

A reinforced bag or a bag of at least 70-pound basis weight is acceptable. A nonreinforced loose-fill padded bag is not acceptable as an exterior container unless the exterior layer is of at least 60-pound basis weight.

2-2.3 Plastic Bags and Films

2-2.3.1 Plastic Bags

A plastic bag — polyethylene or equivalent — used as a mailing container for an easy load must be stretchable, must resist puncturing, must be relatively leak-proof, and must have the following strength requirements:

- For up to 5 pounds, at least 2 mils thick.
- For up to 10 pounds, at least 4 mils thick.

2-2.3.2 Plastic Films

Heat-shrinkable plastic film — copolymer, irradiated polyethylene, or linear low-density polyolefin — used to form an outer mailing container must meet the following requirements, based on load type and weight restriction:

- For an easy load of up to 5 pounds, at least 3/4 mil thick.
- For an average load of up to 5 pounds, at least 1-1/4 mils thick.

2-2.4 Cloth Bags

For an easy load or an average load of up to 10 pounds, a cloth bag is acceptable if its seams are as strong as the basic material forming the bag.

2-2.5 Bales and Bundles

If it is within postal weight limits, a bale or bundle — a large bound or wrapped package of flat materials — is acceptable if it is adequately compressed and reinforced to contain the contents.

2-3 Boxes

2-3.1 Use and Type

2-3.1.1 Paperboard

A paperboard box (similar to a suit box) is acceptable only for easy and average loads of up to 10 pounds.

2-3.1.2 Metal-Stayed Paperboard

A metal-stayed or stapled paperboard box is acceptable only for easy and average loads of up to 20 pounds.

2-3.1.3 Solid and Corrugated Fiberboard

A solid and corrugated fiberboard box is acceptable for all load types up to the weight and size limits shown in Exhibit 2-3.1.3, unless otherwise specified. The box grade (bursting strength) of a box is printed within the circular or rectangular boxmaker's certificate (pictured here), which lists the box's maximum size and gross weight limits for easy and average loads. The first maximum limit reached for an item to be mailed, whether size or weight, governs the grade of box to be used.

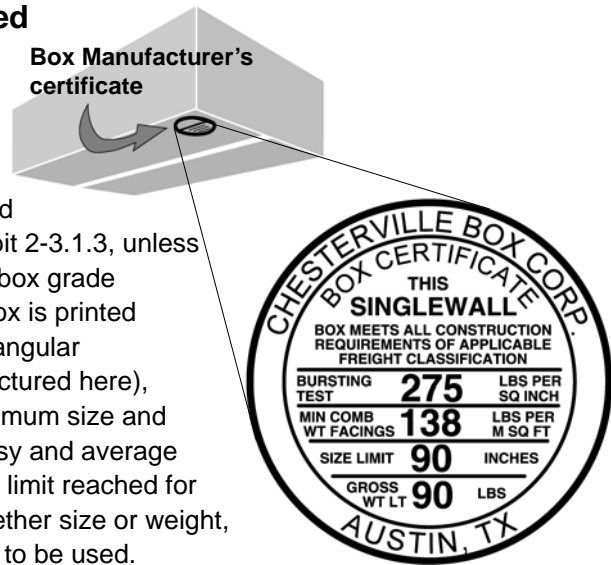

Exhibit 2-3.1.3

Maximum Weight (Box + Contents, Pounds)		Maximum Size (Length + Girth, Inches)	Box Grade (Bursting Strength, Pounds per Square Inch)
Easy or Average Load	Difficult Load		
20	N/A	67	125
40	20	100	175
65	45	108	200
70	65	108	275
N/A	70	108	350

2-3.1.4 Wood, Metal, or Plastic

A wood, metal, or plastic box is acceptable for all load types. The box's acceptability depends on its construction, its ability to withstand shock and pressure, and its potential to damage other items.

2-3.2 Size

A box used as a mailing container must be large enough to hold the items and any surrounding interior cushioning material. If the box is too large and the items inside the box are inadequately blocked or cushioned, the items might shift in transit. If the box is too small, the cushioning might be ineffective protection. In either case, the box or items might get damaged during handling and mail processing.

2-3.3 Making Boxes

If a box of the size required for an item is unavailable, other boxes can be resized. Exhibit 2-3.3 shows how to cut a larger box down to the needed size and how to make an acceptable mailing container from two boxes of the same general dimensions by removing their flaps.

Exhibit 2-3.3

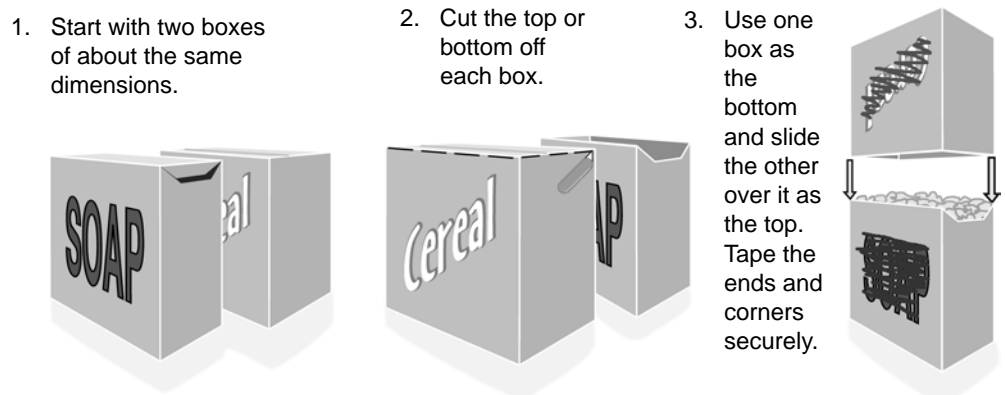
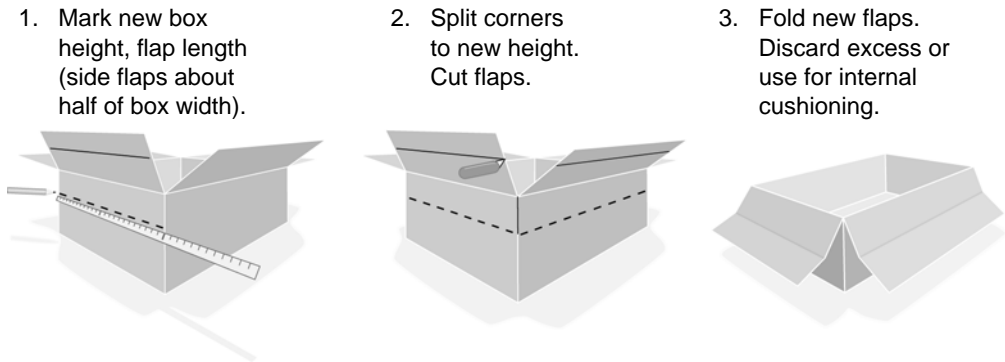

Note: All leftover external markings that do not correctly identify the contents must be fully obliterated.

2-3.4 Banding

A box containing a difficult load must be reinforced with banding (strapping). The box should be banded about every 8 inches in two directions around the box. See 4-3 for more details on banding.



2-3.5 Outer Wrapping

If a box itself is adequate for mailing, wrapping paper should not be used to cover the box. If wrapping paper is necessary, paper as strong as a regular large grocery bag (60-pound basis weight) is recommended. The appropriate type of tape should be used to close and reinforce the box. See 4-5 for more details on selecting and using tape for closing and reinforcing packages.

2-4 Cans and Drums

A can or drum with positive closures (clips, soldered tops, screw-on caps) is acceptable for mailing certain items such as liquids or powders. Generally, a can or drum with only friction closures (push-down types) is not acceptable. Protruding devices (such as locking rings) must be shielded or covered with padding to prevent injury to Postal Service employees or damage to other mail or mail processing equipment.



2-5 Envelopes

2-5.1 Use

Envelopes are acceptable for mailing certain items that can reasonably be expected to be processed and delivered without damage to the contents or to other mail or mail processing equipment.

2-5.2 Letter-Style Envelopes

A letter-style envelope is any nongusseted envelope within the dimensions shown in Exhibit 2-5.2. A letter envelope is acceptable for mailing nonrigid stationery and similar items weighing up to 1 pound and measuring up to 1 inch thick.

Exhibit 2-5.2

Dimension	Minimum (in.)	Maximum (in.)
Length	5	11-1/2 (11.500)
Height	3-1/2 (3.500)	6-1/8 (6.125)
Thickness	0.007	0.250

2-5.3 Other Envelope Styles

For an easy load of up to 5 pounds, an envelope that exceeds the letter-size dimensions is acceptable for mailing. This large envelope should be made from paper of at least 28-pound basis weight or from material with a Mullen strength greater than 90 pounds per square inch.

An envelope designed as a photographic film mailer or a gusseted envelope is also acceptable for mailing if it is made from envelope paper of at least 24-pound basis weight.

2-5.4 Odd-Shaped Items

Pens, bottle caps, and similar odd-shaped items are not acceptable in a letter-sized envelope mailed at the single-piece First-Class Mail rate. These items can split or burst the envelope and injure Postal Service employees or damage other mail and mail processing equipment.

An envelope may be used to mail an odd-shaped item at the bulk Standard Mail rate if the item meets the requirements for that mail class. The item should be wrapped with the other contents of the envelope to streamline the shape of the envelope for automated processing. The item's package should be able to effectively hold it so that the contents and the package will not be damaged.

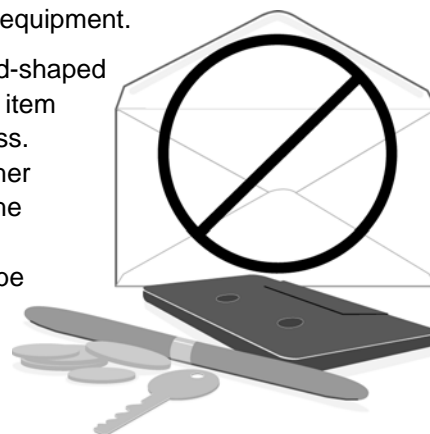

2-6 Tubes

A fiberboard tube or similar long container is acceptable for mailing items if the tube length does not exceed 10 times the girth (the distance around the thickest part of the container). As a minimum, the strength of the tube ends must equal the tube sidewall strength, unless the contents are lightweight rolled items such as maps or blueprints. In any case, the sidewall strength must equal the thickness of the fiberboard, as shown in Exhibit 2-6.

Crimped or taped-end closures are not acceptable for mailing items other than lightweight rolled material. Tape must completely encircle the seams on friction slide closures of mailing tubes.

Exhibit 2-6

Tube Length (in.)	Sidewall Thickness (in.)
Less than 18	1/16 (0.0625)
18 to 32	3/32 (0.09375)
More than 32	5/32 (0.15625)

3 Cushioning

3-1 Purpose and Method

Cushioning is important because, if there is enough cushioning material in a mailing container, it absorbs and distributes forces of shock, pressure, and vibration.

Cushioning should keep an item from touching its mailing container and should separate multiple items from each other. In other words, cushion each item above, below, and on all sides.

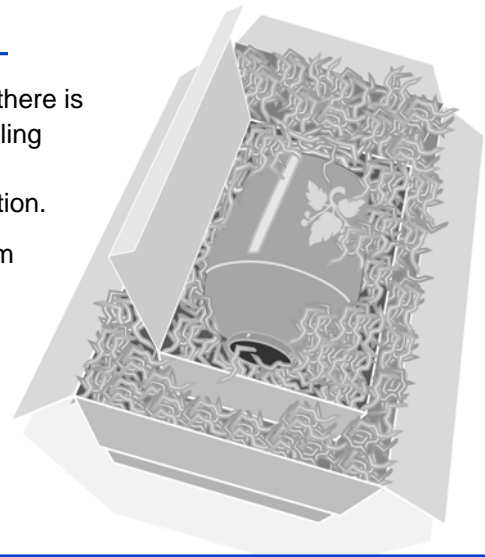

3-2 Materials

Examples of cushioning include foamed plastics, rubberized hair, corrugated fiberboard, and loose-fill material such as excelsior, polystyrene, and shredded newspapers.

Combinations of several types of cushioning (such as corrugated fiberboard pads and less dense, loose-fill material) can be effective. Such combinations help dissipate shock and pressure by spreading these forces over the surface of the items.

3-3 Fill Level

The inside of the mailing container should be slightly overfilled with cushioning material to hold items in place and prevent their movement toward an inside surface of the container or toward other items in the container.

The container should not be distorted by overfilling.

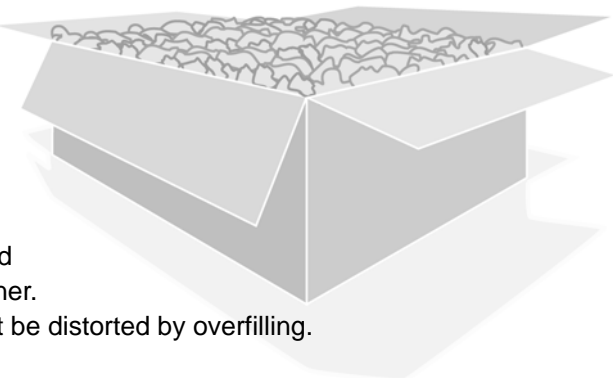

3-4 Several and Fragile Items

When several items are packed together, they should be protected from one another and from external forces.

The illustration on this page shows some ways to cushion several fragile items to be packaged together. The items can be individually wrapped in paper or foam packing material and boxed separately. The boxes can be fortified by surrounding them with corrugated cardboard stiffeners. The boxes can then be placed in the external container and cushioned on all sides and on the top and bottom with styrofoam particles or “peanuts.”

Concentrated heavy items should not be packed with fragile items unless they are carefully separated. Heavy items must be adequately blocked or stabilized.

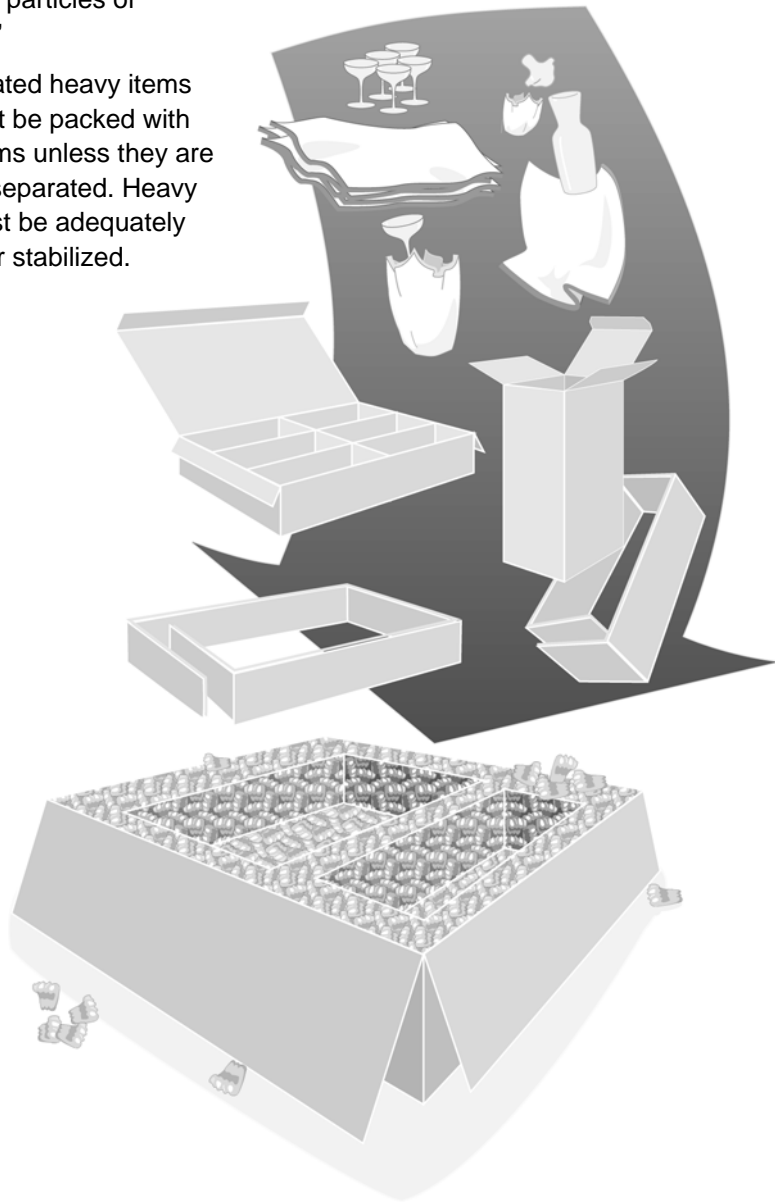

4 Closing, Sealing, and Reinforcing

4-1 General

Closing, sealing, and reinforcing are primary considerations in preparing the outside of a parcel for mailing. The main materials for closing, sealing, and reinforcing mailing containers are adhesives, bandings (strappings), staples and steel stitching, and tapes (gummed and pressure-sensitive). Friction closures, screw caps, and locking devices are used to close and seal cans and similar containers.

4-2 Adhesives

4-2.1 General

Adhesives include glue, paste, cement, mucilage, cold emulsion, and thermal plastic. An adhesive used to close a container is adequate if, when the container is opened, at least a 50-percent fiber tear occurs on the surface to which the adhesive is applied. An adhesive used on tapes or box flaps must remain serviceable in temperatures from -20° to 160° Fahrenheit.

4-2.2 Box Flaps

For box flaps, the adhesive should cover at least 50 percent of the box flaps and be applied no more than 1/4 inch from the box flap ends.

Alternatively, four strips of hot-melt adhesive may be used on each part of the box flap where the outer flap lies over the inner flap, but only if the strips have the following characteristics:

- Are 3/16 inch wide each (after compression).
- Are no more than 1-1/2 inches apart (with the first strip no more than 1/2 inch from the center seam).
- Extend to the full width of the inner flap (unless hot-melt adhesive is applied to 25 percent of the area where the outer flap lies over the inner flap).

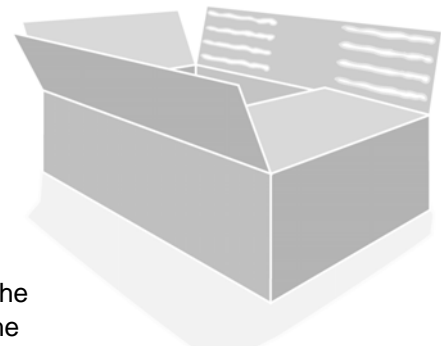

4-3 Bandings

Bandings (strappings) include both metallic and nonmetallic banding and pressure-sensitive filament tape. Flat steel banding should have smooth or plastic-coated edges, and banding ends should be covered or protected. Twine or cord should not be used to close and reinforce a container; if used, it must be of at least 20-pound tensile strength and secured at an intersection at least once on each side of the container.

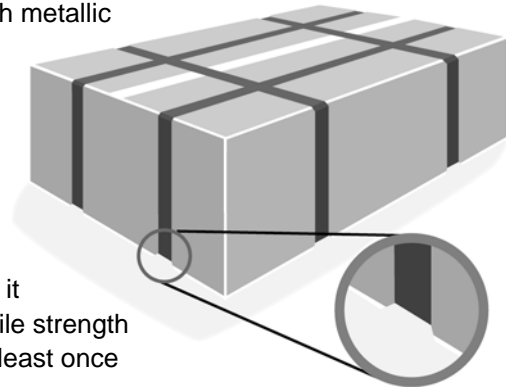

When a mailing container is closed and reinforced with banding (strapping), at least one band must encircle the length and a second band must encircle the girth. Loose strapping, especially metal, is not acceptable because it does not reinforce the container and because it constitutes a danger to Postal Service employees and mail processing equipment. The bands should be tight enough to depress the corners of the box.

4-4 Staples and Steel Stitching

Staples and steel stitching are acceptable for closing a mailing container if they are spaced for the load type as follows:

- For an easy load or an average load, not more than 5 inches apart.
- For a difficult load, not more than 2-1/2 inches apart.

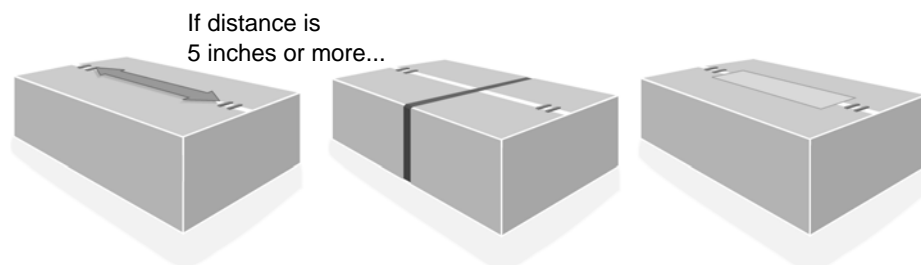

Staples must not be more than 1-1/4 inches from the ends of the box or mailing container. If a box's staple spacing does not meet these requirements, the box should be banded to compensate for the gap in the staple closure, or a strip of 3-inch-wide reinforced tape should be applied to the box between the staples (as shown in the illustration).

Envelopes, flat-size mailing containers, or cards that have partially opened staples are not acceptable for mailing.

4-5 Tapes

4-5.1 Use

Tapes are used to close, seal, and reinforce mailing containers. Commonly available tapes have pressure-sensitive adhesive or gummed adhesive, with either reinforced (filament) or nonreinforced backings.

However, certain types of tapes (such as cellophane and masking tapes) are not strong enough for reinforcing.

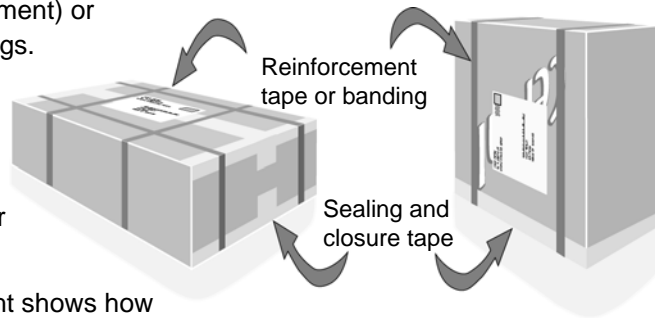

The illustration at right shows how sealing tape can be combined with banding or reinforcement tape to produce an effective closure for boxes with flaps and for telescoping boxes.

4-5.2 Pressure-Sensitive Tape

Pressure-sensitive tape is acceptable for closing and reinforcing mailing containers. This type of tape is available with various cloth, paper, or plastic backings, both plain and reinforced. Except for pressure-sensitive filament tape, tape used to close and reinforce mailing containers may not be less than 2 inches wide. Nonreinforced plastic tapes must be at least as strong in the cross direction as in the machine (long) direction.

Pressure-sensitive filament tape



Kraft paper tape

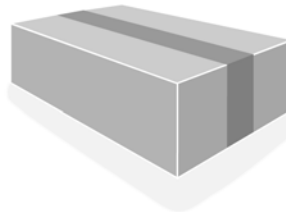

Reinforced kraft paper tape

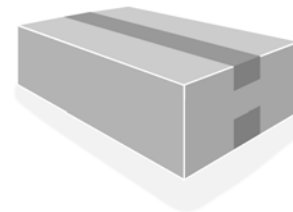

Pressure-sensitive tape works best when applied to clean surfaces at temperatures above freezing. In below-freezing temperatures, the tape should be rubbed down after it is applied.

Cellophane and masking tapes may not be used to close or reinforce containers. These tapes may be used, however, on envelopes to augment adhesive closures or on bags to cover staples.

4-5.3 Gummed Tape

Gummed tape is acceptable for closing and reinforcing mailing containers if the adhesive is adequately activated, usually with water. If the adhesive is improperly activated or the fibrous material of the container absorbs the water, the gummed tape cannot stick to the container.

Gummed tape is applied correctly if it remains attached to the container during handling and transportation and its removal causes delamination or at least a 50-percent fiber tear on the surface to which the tape is applied.

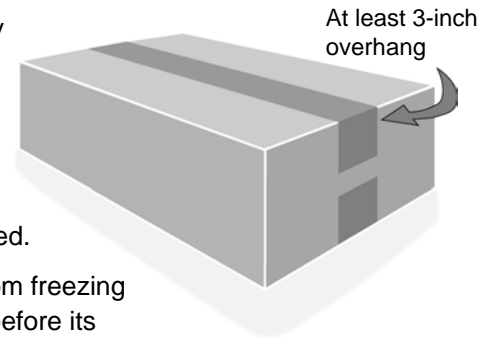

The tape should be kept away from freezing temperatures for at least 1 hour before its application. Even properly applied gummed tape tends to crack in extremely cold temperatures.

Gummed paper tape is available in two types:

- **Reinforced Paper (Kraft).** Reinforced paper (kraft) tape is acceptable for closing and reinforcing irregular-shaped or soft-wrapped packages. A mailing container closed with reinforced paper tape is more durable than one closed with nonreinforced paper tape.
- **Nonreinforced Paper (Kraft).** Nonreinforced paper (kraft) tape is acceptable for closing mailing containers if the tape is of at least 60-pound basis weight. This tape is inadequate for reinforcement. When applied, the tape should extend at least 3 inches over the adjoining side of the container.

5 Marking

5-1 Authorized Markings

5-1.1 General

The DMM and the IMM provide information on addressing standards and endorsements required for each class of mail and service. Special markings are also required for certain restricted items. Contact a business mail entry unit for guidance (see DMM G042 for addresses).

As a rule, the following markings are permitted on the outside of a mailing container:

- Return and delivery addresses.
- Ancillary service endorsements for address correction, forwarding, etc.
- Special service endorsements.
- Class of mail marking.
- Handling instructions.

5-1.2 Address

Each package must show a delivery address on the mailing container or on a label affixed to the container. In addition, a return address must be placed in the upper left corner of the container (or address label).

The addresses should meet postal address format standards. Publication 28, *Postal Addressing Standards*, provides detailed information about address formats and requirements.

Inside the mailing container, the names and addresses of the sender and addressee and a description of the enclosed items should be included. This precaution can aid in the delivery of a parcel if the addresses on the outside of the container become unreadable or the items become separated from the container.

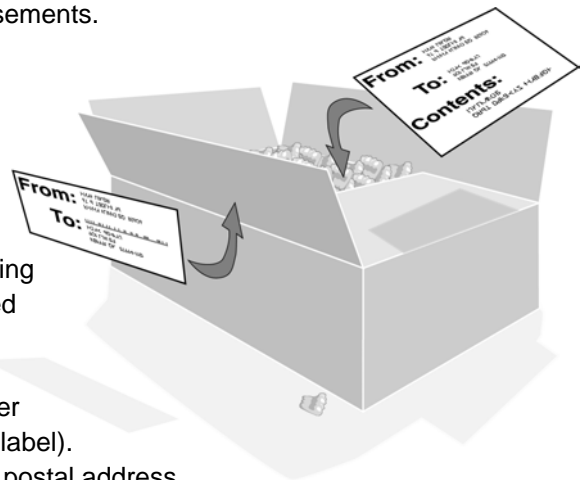

5-1.3 Address Correction and Forwarding

The various ancillary service endorsements for address correction service and the return and forwarding of parcels are fully described in DMM module F. These endorsements must be placed below the return address in the upper left corner or as allowed in DMM M012.



5-1.4 Class of Mail

The class of mail marking is required for all classes of letters, parcels, and flat-size mail except First-Class Mail with postage affixed (under 13 ounces). Mailpieces that have Standard Mail or Package Services postage affixed but are not marked as such are processed at the higher, First-Class Mail rate as postage-due mail.

The class marking must be placed in the area to the left of the postage and above the delivery address, as shown in the illustrations at right.

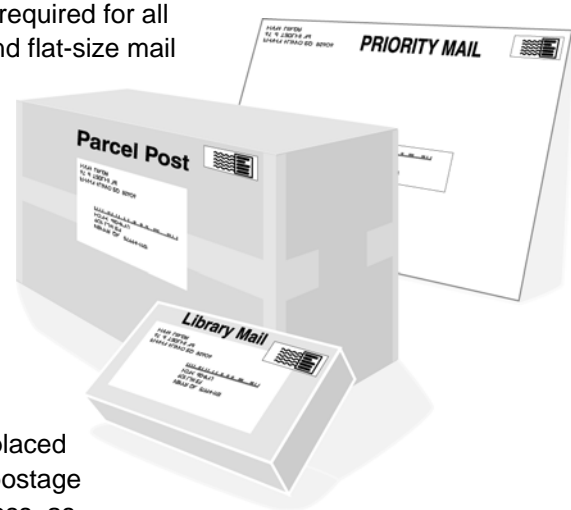

5-1.5 Special Services

All markings for any special service requested must be placed above the delivery address and to the right of the return address. Special services include the following:

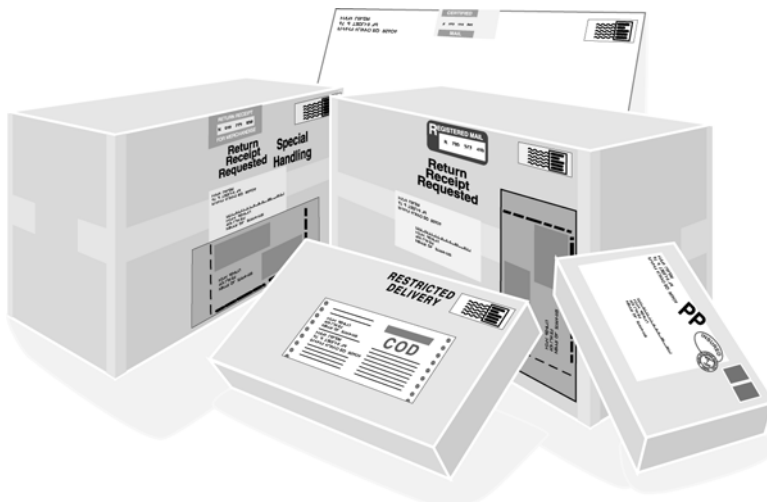

- Certified mail.
- Collect on delivery (COD).
- Delivery confirmation.
- Insured mail.
- Registered mail.
- Restricted delivery.
- Return receipt.
- Return receipt for merchandise.
- Signature confirmation.

5-1.6 Handling Instructions

Approved markings that give handling instructions based on the contents of the package are listed in Exhibit 5-1.6, along with guidelines for using these markings. The markings must be placed in the area below the postage but above the addressee's name.

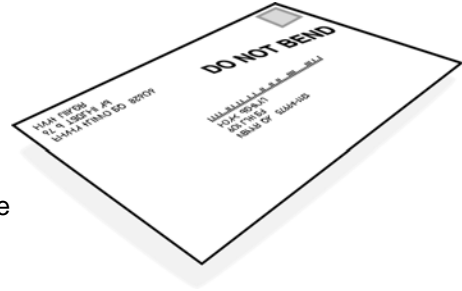

Exhibit 5-1.6

Marking	Use
FRAGILE	Only on packages containing items that can break (such as glass and electrical appliances)
PERISHABLE	Only on packages containing items that can degrade or decompose rapidly (such as meat, produce, plants, and certain chemical samples)
DO NOT BEND or DO NOT FOLD	Only on packages containing items protected with stiffeners

5-2 Unauthorized Markings

5-2.1 Obsolete Markings

Obsolete markings (from previous mailings or on reused boxes or containers) must be entirely removed or completely obliterated prior to mailing.

5-2.2 Erroneous Markings

Containers with improperly identified contents are not acceptable, as noted in the following examples:

- A parcel marked "Bleach" that actually contains clothing is not acceptable.
- A parcel marked "ART SUPPLIES" that actually contains a flammable liquid is not acceptable, even if the liquid is technically an art supply like paint thinner. The potential danger of the liquid's flammability must be identified through the proper external markings required by 49 CFR and DMM C023.

5-2.3 Extraneous Markings

Extraneous information (such as order numbers) that can be confused with ZIP Codes may not be printed immediately under the last line of the address.

5-2.4 **Other Markings**

If other markings are used, such as advertising messages and company logos, they must be placed in areas that do not conflict with the essential information areas described in 5-1.

5-3 **Marking Methods and Surfaces**

5-3.1 **Marking Methods**

Any required address, marking, or endorsement placed on the outside of a mailing container should be made with a waterproof material that cannot be rubbed off or smeared. The lettering must be sharp and readable at a distance of 30 inches.

5-3.2 **Surfaces**

Marking methods and container surfaces must allow application and retention of adhesive stamps, postage meter impressions, and postal endorsements made by hand stamp, ballpoint pen, or number 2 pencil. Address labels and, particularly, outside envelopes must be firmly sealed and attached to containers, with no more than 1/8-inch separation between the ends of the envelope and the container.

A container that does not meet these marking requirements and has caused previous mail processing problems is not acceptable for mailing.

6 Bulk Mail Center Standards

6-1 About This Chapter

The standards in this chapter apply to mailpieces of any class that are processed individually at a bulk mail center (BMC) in the bulk mail system. For alternatives to these standards, mailers should follow the procedures for testing packaging in 1-5.

6-2 Books

6-2.1 General

6-2.1.1 Definition of Book

For packaging purposes only, a book is defined as a printed item with 24 pages or more, fastened together along one edge between hardback covers, paperback covers, or self-covers. All catalogs and similar printed material that meet this definition may be packaged as books.

6-2.1.2 Containers

A fiberboard box of the right size and grade is generally the best type of container for mailing books. If a book is lighter than 1 pound and thinner than 1 inch, it may be mailed in a letter-style envelope. If the book is heavier than 1 pound or thicker than 1 inch, the envelope must be a stronger type, as defined in 2-5.

6-2.1.3 Causes of Damage

A mailing of books or catalogs can become damaged principally for the following reasons:

- The outer container collapses or falls apart because the closure, reinforcement, or size and strength of the container are insufficient.



- The contents shift within the mailing container in transit because bracing or internal packaging is inadequate.

To prevent shifting of the contents or damage to the contents and mailing container, empty spaces in a container holding books must be filled with cushioning material.

6-2.2 Books up to 5 Pounds

6-2.2.1 Packing

A mailing of books weighing up to 5 pounds must be packed in a close-fitting paperboard or fiberboard box, padded or reinforced bag (with an exterior ply of at least 60-pound basis weight), or paper wraps (corrugated or of at least 60-pound basis weight). The mailing container should be at least 1/4 inch thick. For a paperboard mailing container, the books inside should support the container and should fit snugly enough to restrict any lateral shift to no more than 1/2 inch.

For a mailing of paperback books weighing up to 3 pounds, shrinkwrap may be used as the *only* packaging method. Shrinkwrap should have a coefficient of friction (ability to slide on a smooth, hard surface) between 0.025 and 0.040 on metal surfaces at 20- to 25-degree elevations. Shrinkwrap is not acceptable as the *only* packaging method for hardback books thicker than 1 inch or heavier than 1 pound.

6-2.2.2 Closing

The mailing container must be closed with multiple friction closures (the insertion of more than one flap or tab), staples or steel stitching (completely clinched to avoid injuries in handling), heat sealing, adhesive, tape, or nonmetallic banding. Shrinkwrap may be used on the exterior of an otherwise properly closed container.

6-2.3 Books From 5 to 10 Pounds

6-2.3.1 Packing

A mailing of books weighing from 5 to 10 pounds must be packed in at least a 175-pound test fiberboard box (or equivalent). It is a good idea to use a buffer above and below the books to protect them in case the box is opened with a sharp instrument.

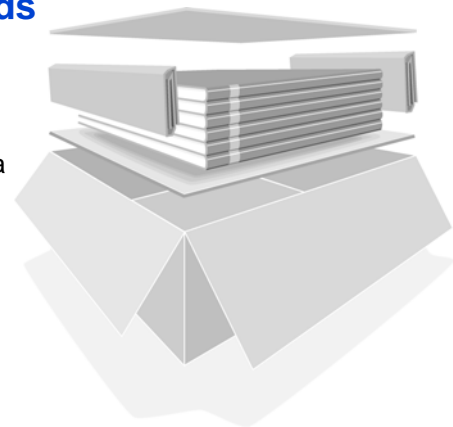

6-2.3.2 Closing

The mailing container must be closed with adhesive, reinforced tape, or firmly applied nonmetallic banding. For nonmetallic banding to be acceptable, the bands must be tight enough to depress the edges of the container, as

illustrated in 4-3. Reinforced tape or nonmetallic banding is adequate both to close and to reinforce the container.

6-2.4 Books From 10 to 25 Pounds

6-2.4.1 Packing

A mailing of books weighing from 10 to 25 pounds must be packed in at least a 200-pound test fiberboard box (or equivalent).

6-2.4.2 Closing

The mailing container must be closed with adhesive, reinforced paper tape, reinforced plastic tape, pressure-sensitive filament tape, or firmly applied nonmetallic banding. For nonmetallic banding to be acceptable, the bands must be tight enough to depress the edges of the container.

The container should be banded or reinforced in the direction providing the most support. For this purpose, reinforced paper tape, reinforced plastic tape, pressure-sensitive filament tape, or firmly applied nonmetallic banding should be used. Reinforced tape or nonmetallic banding is adequate both to close and to reinforce the container.

6-2.5 Books From 25 to 50 Pounds

6-2.5.1 Packing

A mailing of books weighing from 25 to 50 pounds must be packed as follows: for hardback books, in at least a 275-pound test fiberboard box (or equivalent); for paperback books, in at least a 200-pound test fiberboard box (or equivalent).

6-2.5.2 Closing

The mailing container must be closed with adhesive, reinforced paper tape, reinforced plastic tape, pressure-sensitive filament tape, or firmly applied nonmetallic banding. For nonmetallic banding to be acceptable, the bands must be tight enough to depress the edges of the container.

The container should be banded or reinforced at two points to provide the most support. For this purpose, reinforced paper tape, reinforced plastic tape, pressure-sensitive filament tape, or firmly applied nonmetallic banding should be used.

6-2.6 Books From 50 to 70 Pounds

6-2.6.1 Packing

A mailing of books weighing from 50 to 70 pounds must be packed as follows: for hardback books, in at least a 350-pound test fiberboard box (or equivalent); for paperback books, in at least a 275-pound test fiberboard box (or equivalent).

6-2.6.2 Closing

The mailing container must be closed with adhesive, reinforced paper tape, reinforced plastic tape, pressure-sensitive filament tape, or firmly applied nonmetallic banding. For nonmetallic banding to be acceptable, the bands must be tight enough to depress the edges of the container.

The container should be banded or reinforced at two points to provide the most support. For this purpose, reinforced paper tape, reinforced plastic tape, pressure-sensitive filament tape, or firmly applied nonmetallic banding should be used.

6-3 High-Density Items

6-3.1 General

High-density items are solid objects whose weight is comparatively high for their volume. Examples include tools, hardware, machine and auto parts, and other metal or heavy items (but not books).

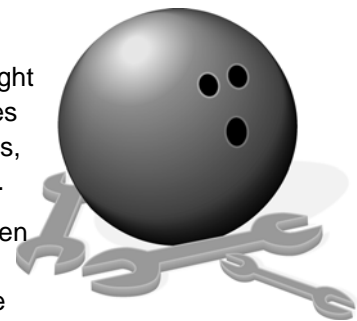

A mailing of high-density items weighing between 15 and 35 pounds is usually machinable on Postal Service mail processing equipment if the contents exert no more than 60 pounds of pressure per square foot (0.4167 pound per square inch) on the smallest side of the container.

A container packed with high-density items often becomes damaged for two reasons:

- The blocking, bracing, or cushioning inside the container is inadequate to prevent shifting of the items.
- The container, the closure, or the reinforcement outside the container is insufficient to withstand normal mail processing.

6-3.2 High-Density Items up to 20 Pounds

6-3.2.1 Packing

A mailing of high-density items weighing up to 20 pounds must be packed in at least a 200-pound test fiberboard box or an equivalent wood, metal, or plastic container. A hard nonfiberboard container should be prepared so that its coefficient of friction is similar to that of a domestic-class fiberboard box of the same size and weight.

Internal blocking and bracing must be used as required (methods include interior containers, cut forms, partitions, dunnage, and liners). The mailing container must maintain its integrity without damage to its contents if dropped once from a height of 3 feet on its smallest side onto a solid surface.

6-3.2.2 Closing

The mailing container must be securely closed with staples, heat sealing, adhesive, or tape. A container without inner packing or a container with loose material should be reinforced with reinforced paper or plastic tape, pressure-sensitive filament tape, or firmly applied nonmetallic banding.

6-3.3 High-Density Items From 20 to 45 Pounds**6-3.3.1 Packing**

A mailing of high-density items weighing from 20 to 45 pounds must be packed in at least a 200-pound test fiberboard box or an equivalent wood, metal, or plastic container. A hard nonfiberboard container must be prepared so that its coefficient of friction is similar to that of a domestic-class fiberboard box of the same size and weight.

Internal blocking and bracing must be used as required (methods include interior containers, cut forms, partitions, dunnage, and liners). The mailing container must maintain its integrity without damage to its contents if dropped once from a height of 3 feet on its smallest side onto a solid surface.

6-3.3.2 Closing

The mailing container must be securely closed with staples, heat sealing, adhesive, or tape. A container without inner packing or a container with loose material should be reinforced with pressure-sensitive filament tape or firmly applied nonmetallic banding.

6-3.4 High-Density Items From 45 to 70 Pounds**6-3.4.1 Packing**

A mailing of high-density items weighing from 45 to 70 pounds must be packed in at least a 275-pound test fiberboard box or an equivalent wood, metal, or plastic container. A hard nonfiberboard container must be prepared so that its coefficient of friction is similar to that of a domestic-class fiberboard box of the same size and weight.

Internal blocking and bracing must be used as required (methods include interior containers, cut forms, partitions, dunnage, and liners). The mailing container must maintain its integrity without damage to its contents if dropped once from a height of 3 feet on its smallest side onto a solid surface.

6-3.4.2 Closing

The mailing container must be securely closed with staples, heat sealing, adhesive, or tape. A container without inner packing or a container with loose material should be reinforced with pressure-sensitive filament tape or tight nonmetallic banding.

6-4 Soft Goods

6-4.1 General

Soft goods include textile items like clothing; sheets, blankets, pillows, and pillow cases; draperies; and cloth and fabric. Containers for these items can be badly damaged if they are inadequately closed or cannot withstand puncture, friction, or compression during normal handling.

6-4.2 Soft Goods up to 5 Pounds

6-4.2.1 Packing

A mailing of soft goods weighing up to 5 pounds should be packed in a cloth bag, a paper bag, paper wraps (with an exterior ply of at least 50-pound basis weight), a plastic bag (at least 2-mil-thick polyethylene or equivalent), or a paperboard or fiberboard box. If a box is used, it must be filled to capacity.

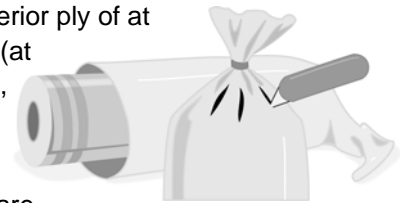

If a paper bag, plastic bag, or paper wraps are used, the container should be vented so it will not burst if compressed quickly.

6-4.2.2 Closing

A bag should be closed with heat sealing, adhesive, sewing, tape, or completely clinched staples. Improperly clinched staples must be removed to prevent injury to Postal Service employees or damage to other mail or mail processing equipment.

A box should be closed with staples, adhesive, heat sealing, nonmetallic banding, or tape. Paper or plastic tape should be applied along all box flaps and closure seams. Although shrinkwrap is not acceptable as the *only* means of packaging, it may be used on the exterior of an otherwise properly closed box. When a box weighs less than 5 pounds (or its density is less than 4 pounds per cubic foot), it should be reinforced in at least two of the longest directions.

6-4.3 Soft Goods From 5 to 10 Pounds

6-4.3.1 Packing

A mailing of soft goods weighing from 5 to 10 pounds should be packed in a cloth bag, a paper bag, a filament-reinforced paper bag, a fiberboard box, paper wraps (with an exterior ply of at least 70-pound basis weight), or a plastic bag (at least 4-mil-thick polyethylene or equivalent).

6-4.3.2 Closing

A bag should be closed with heat sealing, adhesive, sewing, tape, or completely clinched staples. Improperly clinched staples must be removed to

prevent injury to Postal Service employees or damage to other mail or mail processing equipment.

A box should be closed with staples, adhesive, heat sealing, nonmetallic banding, or tape. Paper or plastic tape should be applied along all box flaps and closure seams. Although shrink-wrap is not acceptable as the *only* means of packaging, it may be used on the exterior of an otherwise properly closed box. Reinforced tape is adequate both to close and reinforce the container.

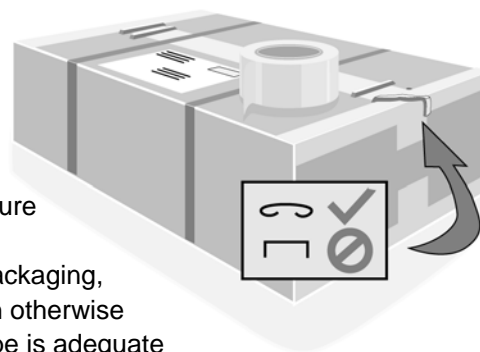

6-4.4 Soft Goods From 10 to 20 Pounds

6-4.4.1 Packing

A mailing of soft goods weighing from 10 to 20 pounds should be packed in a paper bag, paper wraps (with an exterior ply of at least 70-pound basis weight), a reinforced paper or cloth bag, or a 175-pound test fiberboard (or stronger) box.

6-4.4.2 Closing

The mailing container should be closed with staples, adhesive, reinforced paper tape, or equally strong plastic tape. The container should be optimally reinforced with pressure-sensitive filament tape or tight nonmetallic banding. Reinforced tape is adequate both to close and reinforce the container.

6-4.5 Soft Goods From 20 to 45 Pounds

6-4.5.1 Packing

A mailing of soft goods weighing from 20 to 45 pounds should be packed in a paper bag, paper wraps (with an exterior ply of at least 70-pound basis weight), a reinforced paper or cloth bag, or a 200-pound test fiberboard (or stronger) box.

6-4.5.2 Closing

The mailing container should be closed with staples, adhesive, reinforced paper tape, or equally strong plastic tape. The container should be reinforced with reinforced paper or plastic tape, pressure-sensitive filament tape, or tight nonmetallic banding.

6-4.6 Soft Goods From 45 to 70 Pounds

6-4.6.1 Packing

A mailing of soft goods weighing from 45 to 70 pounds should be packed in a paper bag, paper wraps (with an exterior ply of at least 70-pound basis

weight), a reinforced paper or cloth bag, or a 275-pound test fiberboard (or stronger) box.

6-4.6.2 **Closing**

The mailing container should be closed with staples, adhesive, reinforced paper tape, or equally strong plastic tape. The container should be reinforced with reinforced paper or plastic tape, pressure-sensitive filament tape, or tight nonmetallic banding.

6-5 **Sound Recordings**

6-5.1 **General**

Sound recordings, for the purpose of packaging only, are plastic, nonbreakable disc-type records (normally 33-1/3, 45, or 78 RPM) or compact disks normally used with home and auto sound-reproducing equipment. For magnetic tapes and cassette tapes, see 6-6.

6-5.2 **Sound Recordings up to 10 Pounds**

6-5.2.1 **Packing**

A mailing of sound recordings (in paper sleeves, paperboard, or chipboard shells) weighing up to 10 pounds must be packed in at least one other shell (paperboard, chipboard, or plastic) in an outer corrugated fiberboard container.

6-5.2.2 **Closing**

The outer mailing container must be securely closed with adhesive, kraft paper tape, equivalent plastic tape, or staples.

6-5.3 **Sound Recordings From 10 to 20 Pounds**

6-5.3.1 **Packing**

A mailing of sound recordings (in paper sleeves, paperboard, or chipboard shells) weighing from 10 to 20 pounds must be packed in at least one other shell (paperboard, chipboard, or plastic) in an outer corrugated fiberboard container.

6-5.3.2 **Closing**

The outer mailing container must be securely closed with adhesive, kraft paper tape, equivalent plastic tape, or staples. It should then be reinforced in at least one direction with reinforced paper tape, reinforced plastic tape, pressure-sensitive filament tape, or firmly applied nonmetallic banding. Reinforced tape is adequate both to close and reinforce the outer container.

6-5.4 **Sound Recordings From 20 to 40 Pounds**

6-5.4.1 **Packing**

A mailing of sound recordings (in paper sleeves, paperboard, or chipboard shells) weighing from 20 to 40 pounds must be packed in at least one other shell (paperboard, chipboard, or plastic) in at least a 175-pound test fiberboard outer box (or equivalent).

6-5.4.2 **Closing**

The outer mailing container must be securely closed with adhesive, kraft paper tape, equivalent plastic tape, or staples. It should also be reinforced at two points with pressure-sensitive filament tape or firmly applied nonmetallic banding. Reinforced tape is adequate both to close and reinforce the outer container.

6-5.5 **Sound Recordings From 40 to 70 Pounds**

6-5.5.1 **Packing**

A mailing of sound recordings (in paper sleeves, paperboard, or chipboard shells) weighing from 40 to 65 pounds must be packed in at least one other shell (paperboard, chipboard, or plastic) in at least a 200-pound test fiberboard outer box (or equivalent). A mailing weighing from 65 to 70 pounds must be packed in multiple shells in at least a 275-pound test fiberboard box (or equivalent).

6-5.5.2 **Closing**

The outer mailing container must be securely closed with adhesive, kraft paper tape, equivalent plastic tape, or staples. In addition, the outer container must be reinforced at about 8-inch intervals on all sides around the container. Reinforced tape is adequate both to close and reinforce the outer container.

6-6 **Magnetic Tapes**

6-6.1 **General**

Magnetic tapes, cassette tapes, and cartridges present special problems when their mailing containers (especially for small quantities) or reinforcement (for large quantities) are inadequate.

6-6.2 **Magnetic Tapes up to 5 Pounds**

6-6.2.1 **Packing**

For a single tape, the tape must be packed in a plastic film wrap of at least 0.75 mil, in a cushioned bag, or in a cushioned paper bag of at least

60-pound basis weight. Multiple tapes up to 5 pounds must be packed in an outer container of fiberboard or chipboard at least 22 mils thick.

6-6.2.2 **Closing**

The outer mailing container must be securely closed with tape, heat sealing, adhesive, completely clinched staples, or a multiple friction closure (two or more flaps or tabs). Paper tape must be of at least 60-pound basis weight kraft. Shrinkwrap may be used on the outside of an otherwise properly closed box. Reinforced tape is adequate both to close and reinforce the outer container.

6-6.3 **Magnetic Tapes From 5 to 10 Pounds**

6-6.3.1 **Packing**

A mailing of tapes weighing from 5 to 10 pounds must be packed in an outer container of fiberboard or chipboard at least 22 mils thick. Tapes should be packed in multiple shells for additional protection.

6-6.3.2 **Closing**

The outer mailing container must be securely closed with tape, adhesive, or completely clinched staples. Paper tape must be of at least 60-pound basis weight kraft. An otherwise properly closed box may be shrinkwrapped. Reinforced tape is adequate both to close and reinforce the outer container. Tapes should be packed in multiple shells for additional protection.

6-6.4 **Magnetic Tapes From 10 to 20 Pounds**

6-6.4.1 **Packing**

A mailing of tapes weighing from 10 to 20 pounds must be packed in an outer container of fiberboard or chipboard at least 22 mils thick.

6-6.4.2 **Closing**

The outer mailing container must be securely closed with tape, adhesive, or completely clinched staples. Paper tape must be of at least 60-pound basis weight kraft. The container should be reinforced in a direction that provides the most support with reinforced paper or plastic tape, pressure-sensitive filament tape, or tight nonmetallic banding. Reinforced tape is adequate both to close and reinforce the box. An otherwise properly closed box may be shrinkwrapped.

6-6.5 **Magnetic Tapes From 20 to 40 Pounds**

6-6.5.1 **Packing**

A mailing of tapes weighing from 20 to 40 pounds must be packed in at least a 175-pound test fiberboard box (or equivalent). Tapes should be packed in multiple shells for additional protection.

6-6.5.2 Closing

The outer mailing container must be securely closed with tape, adhesive, or completely clinched staples. Paper tape must be of at least 60-pound basis weight kraft. The container must be reinforced at two points with reinforced paper or plastic tape, pressure-sensitive filament tape, or tight nonmetallic banding. An otherwise properly closed box may be shrinkwrapped.

6-6.6 Magnetic Tapes From 40 to 70 Pounds**6-6.6.1 Packing**

A mailing of tapes weighing from 40 to 65 pounds must be packed in at least a 200-pound test fiberboard box (or equivalent). A mailing weighing from 65 to 70 pounds must be packed in at least a 275-pound test fiberboard box (or equivalent). Multiple shells should be used for greater protection.

6-6.6.2 Closing

The outer mailing container must be securely closed with tape, adhesive, or completely clinched staples. Paper tape must be of at least 60-pound basis weight kraft. An otherwise properly closed box may be shrinkwrapped. The container must be reinforced at two points with reinforced paper or plastic tape, pressure-sensitive filament tape, or tight nonmetallic banding.

This page intentionally left blank

7 Hazardous Materials

7-1 General

7-1.1 Definition

A hazardous material (referred to as a “dangerous good” in international commerce) is any article or substance having a clear potential for causing harm to the mail or to persons or property involved in moving the mail.

7-1.2 Federal Laws

The Department of Transportation (DOT) regulates all surface and air carriage of hazardous materials within the United States via any means of transportation. DOT regulations on hazardous materials are codified in Title 49, *Code of Federal Regulations* (49 CFR), parts 100–185.

Mailers are reminded that it is a federal crime, punishable by fines and imprisonment, to place in the mails any “natural or artificial articles, compositions, or material which may kill or injure another, or injure the mails or other property” (18 U.S.C. 1716(a)). This statute allows the Postal Service to permit the mailing of some injurious articles under regulations prescribing conditions of preparation and packaging (18 U.S.C. 1716(b)).

For more specific information, see DMM C020 and C023 and Publication 52, *Hazardous, Restricted, and Perishable Mail*.

7-2 Mailing Conditions

7-2.1 Postal Regulations

The Postal Service accepts for mailing a very small number of certain potentially hazardous materials that are not outwardly or of their own force dangerous or injurious to life, health, or property. Generally, this is limited to ORM-D materials that are hazardous materials presenting the lowest level of risk during transportation. The conditions of preparation and packaging under which such materials are accepted are explained in the DMM and in Publication 52. Conditions applicable to mailings of hazardous materials to foreign addresses are explained in the IMM.

7-2.2 Mailability Rulings

Postal standards for hazardous materials closely adhere to 49 CFR and very often include additional restrictions and prohibitions. Generally, the acceptability of chemicals and other types of hazardous materials for mailing depends on container fluid/vapor capacities, the ability of the complete package to contain the product, and the method of absorbing and containing the product in case the primary container accidentally leaks. To determine mailability of a specific product, a mailer must submit a material safety data sheet (MSDS) and the following information to the RCSC serving the mailer's location:

- Name of material, hazard class, and assigned UN or NA identification number.
- Chemical composition by percentage of ingredient.
- Flashpoint.
- Toxic properties.
- Effect of material when it is inhaled or swallowed or when it comes in contact with eyes or skin.
- Special precautions necessary to permit handling without harm to USPS employees or damage to property or other mail.
- Explanation of warning labels and shipping papers required by state or federal regulations.
- Proposed packaging method, including addressing and required markings.

7-2.3 Packaging

To be acceptable for mailing, hazardous materials must be packaged as required by DMM C023 and Publication 52.

Package Testing

ISTA Test Procedure 1A

Introduction

International Safe Transit Association (ISTA)

ISTA, the association for transport packaging, is an international leader in advancing the science of packaging and the use of performance testing techniques. Its member companies are supported in the development of effective packaging, methods, and logistic systems that prevent or reduce transportation and handling damage during product distribution. ISTA test procedures are continuously under review and updated periodically. To ensure that you are utilizing the most recent publication of the test procedure, contact ISTA at:

INTERNATIONAL SAFE TRANSIT ASSOCIATION
1400 ABBOTT RD STE 160
EAST LANSING MI 48823-1900

Telephone: 517-333-3437
Fax: 517-333-3813
Internet: www.ista.org

Test Procedure 1A, *Performance Test for Individual Packaged-Products (150 lb (68.2 kg) or Less)*, is copyrighted by ISTA and is reprinted here with its permission.

Preshipment Testing

The ISTA Preshipment Test Procedures provide a means for a manufacturer to predetermine the probability of the safe arrival of their packaged products at their destination through the utilization of tests developed to simulate the shocks and stresses normally encountered during handling and transportation. ISTA has confined its technical activities to the packaged product only. Neither the product nor the container is considered separately. The tests, it is stressed, are basic tests. Test level and sequence should be changed to adapt to known distribution situations and these changes are documented in the report.

These test procedures are performance tests and, when properly applied, will provide tangible benefits of reduced damage, economically balanced costs, and improved customer satisfaction. It is also emphasized that these procedures are not intended to evaluate the protection afforded packaged products from other conditions such as moisture, corrosion, contaminating odors, etc. They may or may not comply with carrier requirements for packaging.

To maintain certified status and eligibility for identification with the TRANSIT TESTED seal, each packaged product must be retested whenever a change is made in either the product, the process, or the package. Changes in the packaged product include changes in design, size, and/or material. As a quality control procedure, packaged products should be retested as frequently as feasible.

Very Important

ISTA 1 Series Integrity Test Procedure

The entire document shall be read and understood before proceeding with a test.

There are three sections: Overview, Testing and Report

- **Overview** provides the general knowledge required before going into the testing laboratory **and**
- **Testing** presents the specific instructions to do the testing in the laboratory **and**
- **Report** indicates what data shall be recorded to submit a test report to ISTA.

ISTA Test Procedures and Test Projects are the worldwide leaders in Performance Tests for Packaged-Products.

Two systems of weights and measures are presented in ISTA test procedures. They are the English system (Inch-Pound) and the international system SI (Metric). Inch-Pound units are shown first with Metric units in brackets, except in some tables where they are shown separately.

- Either system may be used as the unit of measure (standard units), **but**
- The standard units chosen shall be used consistently throughout the procedure.
- Units are converted to two significant figures **and**
- Not exact equivalents.

Overview

Preface

Test Procedure 1A is an integrity test for individual packaged-products.

- It can be used to evaluate the performance of a packaged-product.
- It can be used to compare relative performance of package and product design alternatives.
- The package and product are considered together and not separately.
- Some conditions of transit, such as moisture, pressure or unusual handling, may not be covered.

Other ISTA Procedures may be appropriate for different conditions or to meet different objectives.

Specific suggestions:

- To use random vibration instead of fixed displacement vibration, use ISTA Integrity Test Procedure 1G and not 1A.
- For packaged-products where a minimum compression value should be tested, use ISTA Integrity Test Procedure 1C.
- For packaged-products intended for international distribution consider ISTA Integrity-Plus Test Procedure 2A.
- For packaged-products that may be transported in a small parcel delivery system consider ISTA General Simulation Test Procedure 3C.
- Refer to *Guidelines for Selecting and Using ISTA Projects and Procedures* for additional information.

ISTA 1 Series tests are basic tests that consist of integrity test procedures.

- They are not simulations of actual transport hazards, **and**
- do not necessarily comply with carrier packaging regulations.

When properly applied, ISTA procedures will provide tangible benefits of:

- reduced damage,
- economically balanced costs **and**
- improved customer satisfaction.

Scope

Test Procedure 1A covers testing of individual packaged-products weighing 150 pounds (68.2 kg) or less when prepared for shipment.

Note: To be eligible for mailing, a single parcel cannot exceed 70 pounds.

Product Damage Tolerance and Degradation Allowance

The shipper shall determine the following prior to testing:

- What constitutes damage to the product **and**
- what damage tolerance level is allowable, if any, **and**
- the correct methodology to determine product condition at the conclusion of the test **and**
- the acceptable package condition at the conclusion of the test.

For additional information on this determination process refer to *Guidelines for Selecting and Using ISTA Projects and Procedures*.

Samples

Samples should be the untested actual package and product, but if one or both are not available, the substitutes shall be as identical as possible to actual items.

- *Number of samples required:* One sample is required for the tests in this procedure.
- *Replicate Testing Recommended:* To permit an adequate determination of representative performance of the packaged-product, ISTA:
 - Requires the procedure to be performed a minimum of one time, **but**
 - Recommends performing the procedure five or more times, using new samples with each test.

Note: Packages that have already been subjected to the rigors of transportation cannot be assumed to represent standard conditions. In order to insure testing in perfect condition, products and packages shipped to certified laboratories for testing must be:

- over-packaged for shipment to the laboratory **or**
- repackaged in new packaging at the laboratory.

Test Sequence

The tests shall be performed on each test sample in the sequence indicated in the following table:

Sequence #	Test Category	Test Type	Test Level	For ISTA Certification
1	Vibration	Fixed Displacement	1 in. (25 mm) peak to peak at a frequency to be determined	Required
2	Shock	Drop	Height varies with packaged-product weight	Required
		Alternative Incline (Conbur)	Impact Velocity varies with packaged-product weight	
		Alternative Horizontal Impact)	Impact Velocity varies with packaged-product weight	

Equipment Required Vibration

Equipment required for the Fixed Displacement Vibration Test:

- Vibration Test System with a 1 inch (25 mm) fixed or controlled displacement complying with Method A1 or A2 of the apparatus section of ASTM D 999-96. Rotary or vertical linear motion of the platform is acceptable.
- Metal shim 0.06 inch (1.5 mm), thick approximately 2.0 inches (50 mm) wide and at a convenient length.
- Tachometer or suitable indicator for determining vibration frequency in cycles per second (Hz) or cycles per minute (CPM).
- Automatic timer or stopwatch.

Equipment Required for Shock Test

The following alternatives are acceptable for the equipment required for the Shock Test:

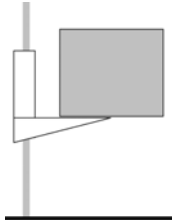

Shock Test: Drop Test
Equipment: Free fall drop tester
***Section:** D 5276-98

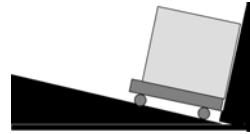

Shock Test: Alternative Incline Test
Equipment: Incline impact tester (conbur)
***Section:** D 880-92 (1997)

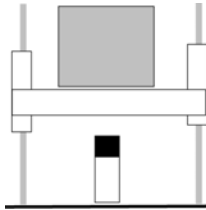

Shock Test: Vertical Shock Test
Equipment: Shock test machine
***Section:** D 5487-98



Shock Test: Alternative Horizontal Test
Equipment: Horizontal impact test system
***Section:** D 4003-98

*In compliance with the apparatus section of ASTM.

Procedure

Identification of Faces, Edges and Corners

Prior to beginning the tests identify the faces, edges and corners according to the procedure below.

Step	Action
1	Place the packaged-product in its intended shipping position as determined by shipper. If the shipping position can be variable, place the packaged-product so that the primary shipping label location is on the top face.
2	Does the packaged-product have only six faces (2 sides, 2 ends, top and bottom)? <ul style="list-style-type: none"> ■ If Yes, then go to Step 5. ■ If No, continue to next Step.
3	Develop a method to identify each face, edge and corner and document with a diagram.
4	Go to the next Block.
5	Is the package a corrugated container? <ul style="list-style-type: none"> ■ If Yes, continue to next Step. ■ If No, then go to Step 8.
6	Does the package have a manufacturer's joint connecting a side and an end face? <ul style="list-style-type: none"> ■ If Yes, continue to next Step. ■ If No, then go to Step 8.
7	Turn the packaged-product so that you are looking directly at a face with the manufacturer's joint on the observer's right and go to Step 9.
8	Position one of the smallest width faces of the packaged-product directly in front of you.
9	Identify faces according to the diagram below.
10	Identify edges using the numbers of the two faces forming that edge. <i>Example:</i> Edge 1-2 is the edge formed by face 1 and face 2 of the packaged-product.
11	Identify corners using the numbers of the three faces that meet to form that corner. <i>Example:</i> Corner 2-3-5 is the corner formed by face 2, face 3, and face 5 of the packaged-product.
12	Go to next Block.

Packaged-Product Weight and Size Measurement

You shall know the packaged-products:

- gross weight in pounds (kg) rounded up to a whole number, **and**
- outside dimensions of Length, Width, and Height (L x W x H) in inches (mm or m).

Before You Begin Vibration Testing

Caution: A restraining device or devices shall be used with the vibration test system to:

- Prevent the test specimen from moving off the platform **and**
- Maintain test orientation of the packaged-product, **but**
- The device or devices shall not restrict the vertical motion of the test specimen during the test.

For Fixed Displacement Vibration:

Step	Action																					
1	<p>Familiarity with the following formula is required to calculate the test duration after the frequency required to bounce the packaged-product is determined in the Vibration Test Block:</p> $\text{Test Duration in Minutes} = \frac{14,200 \text{ Vibratory Impacts}}{\text{Cycles Per Minute (CPM) or} [\text{Cycles Per Second (Hz) x 60}]}$																					
2	<p>The chart below shows example Test Durations calculated for several frequencies:</p> <table border="1"> <thead> <tr> <th>CPM</th> <th>Hz</th> <th>Test Duration in Minutes</th> </tr> </thead> <tbody> <tr> <td>150</td> <td>2.5</td> <td>95</td> </tr> <tr> <td>180</td> <td>3.0</td> <td>79</td> </tr> <tr> <td>210</td> <td>3.5</td> <td>68</td> </tr> <tr> <td>240</td> <td>4.0</td> <td>60</td> </tr> <tr> <td>270</td> <td>4.5</td> <td>53</td> </tr> <tr> <td>300</td> <td>5.0</td> <td>48</td> </tr> </tbody> </table>	CPM	Hz	Test Duration in Minutes	150	2.5	95	180	3.0	79	210	3.5	68	240	4.0	60	270	4.5	53	300	5.0	48
CPM	Hz	Test Duration in Minutes																				
150	2.5	95																				
180	3.0	79																				
210	3.5	68																				
240	4.0	60																				
270	4.5	53																				
300	5.0	48																				

Vibration Test

The table below indicates the steps to perform a Fixed Displacement Vibration Test.

Step	Action
1	Put the packaged-product on the vibration table so that face 3 rests on the platform.
2	Start the vibration system to vibrate at 1.0 inches (25 mm) total displacement at the machine's lowest frequency.
3	Maintain a fixed displacement at 1 inch (25 mm) and slowly increase the frequency (speed) of the vibration table until the packaged-product begins to momentarily leave the surface of the platform.
4	Hold the vibration frequency to that determined in Step 3.
5	Can a metal shim be intermittently moved between the bottom of the longest dimension of the packaged-product and the surface of the platform? <ul style="list-style-type: none"> ■ If Yes, hold that frequency and then continue to next Step. ■ If No, then increase the frequency until the requirement of Step 5 is met and hold that vibration frequency.
6	Determine the test duration in minutes using the formula indicated in the Before You Begin Block and the CPM or Hz frequency identified in Step 5.
7	Begin the vibration duration.
8	Are you using a vertical linear motion on the vibration system? <ul style="list-style-type: none"> ■ If Yes, then go to Step 12. ■ If No, then continue with the next Step.
9	Stop the vibration test halfway through the vibration duration and perform the appropriate action as indicated below: <ul style="list-style-type: none"> ■ IF a single 90° horizontal rotation is <i>possible</i>, THEN perform a horizontal rotation of 90° as the specimen rests on the platform. ■ IF a single 90° horizontal rotation is <i>not practical</i> because of the size of the packaged-product or the stability of the packaged-product, THEN perform a horizontal rotation of 180° as the specimen tests on the platform.
10	Start the vibration system and continue the vibration test at the frequency used in Step 7.
11	Can a metal shim be intermittently moved between the bottom of the longest dimension of the packaged-product and the surface of the platform? <ul style="list-style-type: none"> ■ If Yes, then continue to next Step. ■ If No, then slowly increase the frequency until the requirement of Step 11 is met.
12	Complete vibration duration.
13	Inspection of the packaged-product for visible damage is allowed, provided inspection does not alter, in any way, the current condition of the package or the condition or position of the product(s).
14	Vibration testing is now complete. Go to the Shock Test Block.

Before You Begin Shock Testing

The test drop height varies with the weight of the packaged-product. Find the weight of the packaged-product in the following chart to determine a drop height or an equivalent impact velocity to be used for a substituted drop:

Packaged-Product Weight				Drop Height		Impact Velocity	
Equal to or greater than		But Less than		Free Fall		Incline or Horizontal	
lb	kg	lb	kg	In.	mm	ft/s	m/s
0	0	21	10	30	760	13	3.9
21	10	41	19	24	610	11	3.4
41	19	61	28	18	460	10	3.0
61	28	100	45	12	310	8.0	2.5
100	45	150	68	8	200	6.6	2.0

The test method requires the packaged-product to be dropped in several different package orientations.

A drop test must be performed in all required orientations where dropping the packaged-product is practical.

If dropping in a required orientation is not practical an equivalent incline or horizontal test can be substituted for that orientation.

When using impact velocity, if any test in a Test Sequence is below the required minimum level, that sequence event must be repeated until the test impact velocity meets the minimum.

Shock Test

The table below indicates the steps to perform the Drop Shock Test.

Step	Action		
1	Determine the method(s) of test and the required drop height or impact velocity in the Before You Begin Block.		
2	Do you have a packaged-product with only 6 faces as identified in the Face, Edge and Corner Identification Block? <ul style="list-style-type: none"> ■ If Yes, continue with the next Step. ■ If No, then go to Step 6. 		
3	Test the packaged-product according to the method(s) and level(s) determined in Step 1. Follow the sequence in the table below.		
4	Sequence #	Orientation	Specific face, edge or corner
	1	Corner	most fragile face-3 corner, if not known, test 2-3-5
	2	Edge	shortest edge radiating from the corner tested
	3	Edge	next longest edge radiating from the corner tested
	4	Edge	longest edge radiating from the corner tested
	5	Face	one of the smallest faces
	6	Face	opposite small face
	7	Face	one of the medium faces
	8	Face	opposite medium face
	9	Face	one of the largest faces
	10	Face	opposite large face
5	All testing is now complete. Go to the Test Report Block.		
6	Select a bottom face corner to replace the corner required in Step 4 Sequence 1 to begin the test.		
7	Identify the edges of the packaged-product that meet the Step 4 Sequence 2 through 4 requirements.		
8	Select any 6 faces to replace the faces required in Step 4 Sequence 5 through 10.		
9	Using the corner, edges and faces from Steps 6 through 8 go to Step 3 and proceed.		
10	All testing is now complete. Go to the Test Report Block.		

Report

Before You Begin Report

The packaged-product has satisfactorily passed the test if, upon examination, it meets the Product Damage Tolerance and Package Degradation Allowance.

ISTA Certified Testing Laboratories:

- Should file a test report on all ISTA Test Procedures or Projects conducted.
- Shall file a test report on all ISTA Test Procedures or Projects conducted to obtain Transit Tested Package Certification or Acknowledgement.

For additional information, refer to *Guidelines for Selecting and Using ISTA Test Projects and Procedures*.

ISTA Transit Tested Program

The ISTA Transit Tested Certification Mark as shown is a:

- registered certification mark **and**
- can only be used by license agreement **and**
- by a member of the International Safe Transit Association.



When a member prints this certification mark on a packaged-product with their license number they are showing their customer and the carrier that it has passed the requirements of ISTA preshipment testing.

In order to maintain its certified status and eligibility for identification with the TRANSIT TESTED Certification Mark, each packaged-product must be re-tested whenever a change is made in the:

- Product **or**
- Process **or**
- Package.

Changes in the product include changes in:

- Design **or**
- Size **or**
- Materials.

Changes in the process include changes in:

- Manufacturing **or**
- Assembly **or**
- Filling.

Changes in the package include changes in:

- Configuration **or**
- Dimensions **or**
- Weight **or**
- Materials **or**
- Components.

As a quality control procedure, packaged-products should be re-tested frequently, for example, yearly.

The following diagram indicates the steps in ISTA Test Report Processing.

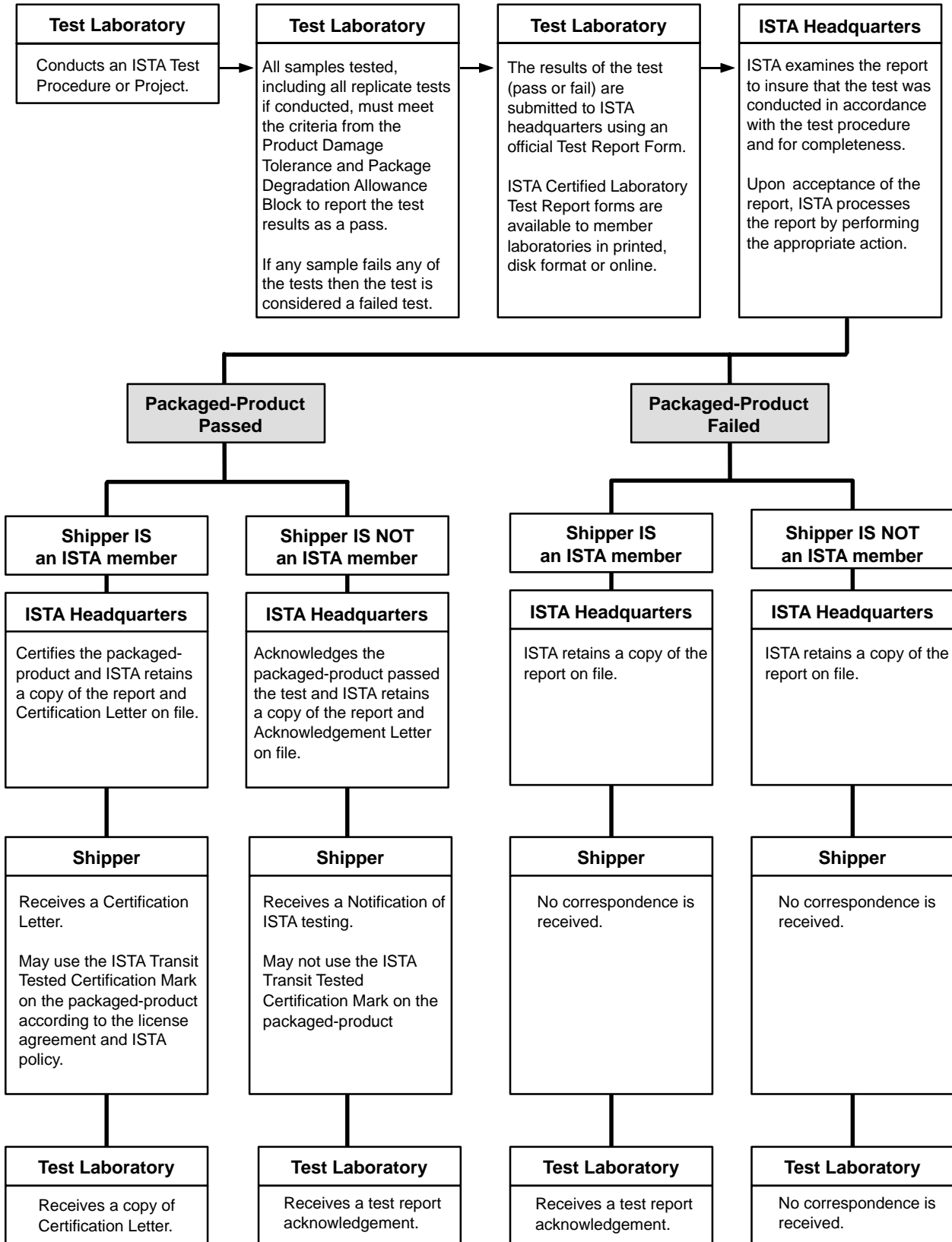

General Requirements

The following information is required when completing the Certified Laboratory Test Report:

ISTA Certified Testing Laboratory Information

- Complete laboratory name and address
- Test Laboratory ID number
- Test Technician who performed the test
- Test Report submitted by: name and signature

Product Manufacturer/Shipper Information

- Manufacturer/Shipper company name and address
- Test requested by (individuals name)
- Manufacturer/Shipper ISTA License Number, if applicable and known

Third-party Test Request Information

- Test conducted for company name and address
- Test requested by (individuals name)
- Relationship to the product manufacturer/shipper

Test Information

- Test Procedure or Project performed
- Date tested
- Number of samples tested
- Number of replicate tests performed
- Test Number(s) assigned by test laboratory, if applicable

Product Description

- Detailed description of the product under test, including model designation or other specific means of product identification that distinguishes it from any other product.

Package Description

- Describe entire shipping unit
- Type or style of package
- List materials used inside the package, if applicable
- Pallet or skid, if applicable
- Picture or drawing of any interior cushioning, if applicable
- Method of closure, if applicable

Packaged-Product Tested

- Gross weight of packaged-product
- External container size in inches (mm or m): Length x Width x Depth (L x W x D)
- A picture should be included

Product Damage Tolerance Criteria

- Definition of product damage tolerance
- Name of who determined definition of product damage tolerance
- Description of the method of determining product damage

Package Degradation Allowance Criteria

- Definition of package degradation allowance
- Name of whom determined definition of package degradation allowance
- Description of the method of determining package degradation

Specific Requirements

The following information is specific to this test procedure and shall be reported with the required general information when completing the Certified Laboratory Test Report:

Test Results

Report if the packaged-product(s):

- Passed **or**
- Failed

Test Plan

- Report which unit of measure was used, English or Metric.
- Report any deviations from the required test plan.
- Include an explanation as to why the test was conducted differently.

Test Laboratory Comments

- As a result of the testing, report any recommendations for packaged-product improvement.
- Any general comments.

Vibration Test

- Describe restraining device or devices used
- First test orientation
 - Orientation of specimen tested
 - Test frequency in Hz or CPM
- Second test orientation
- Report the degrees of rotation, if applicable:
 - 90° **or**
 - 180°
 - Test frequency in Hz or CPM
- Test duration in minutes
- Number of vibratory impacts, **and**
- Results of visual inspection for damage, if applicable

Shock Test

Report the following:

- Orientation of each shock
- Severity of each shock recorded:
 - For Drop Test as drop height in inches (mm)
 - For free fall equivalent as velocity change in inches per second (m/s)
 - For incline as impact velocity in inches per second (m/s)
 - Horizontal equivalent as velocity change in inches per second (m/s)

Report if an incline or horizontal shock was substituted for any test orientation.

- Which orientation
- Which test method was used
 - Free fall equivalent shock, incline or horizontal
- Explain the reason for the substitution for each orientation

This page intentionally left blank

Appendix B

Rates and Classification Service Centers (RCSCs)

Chicago RCSC

3900 GABRIELLE LN RM 111
FOX VALLEY IL 60597-9599

Telephone: 630-978-4329
Fax: 630-978-4295

New York RCSC

1250 BROADWAY 14TH FL
NEW YORK NY 10095-9599

Telephone: 212-613-8676
Fax: 212-613-8752

San Francisco RCSC

33 NEW MONTGOMERY ST STE 1690
SAN FRANCISCO CA 94105-4514

Telephone: 415-247-7200
Fax: 415-357-3684

This page intentionally left blank