

A Multi-Pollutant Framework for Evaluating CO₂ Control Options for Fossil Fuel Power Plants

Edward S. Rubin (rubin@cmu.edu; 412-268-5897)
Anand B. Rao (abr@andrew.cmu.edu; 412-268-5605)
Michael B. Berkenpas (mikeb@cmu.edu; 412-268-1088)
Carnegie Mellon University
EPP Department, Baker Hall 128A
Pittsburgh, PA 15213

Abstract

As part of DOE/NETL's Carbon Sequestration Program, we are developing an integrated, multi-pollutant modeling framework to evaluate the costs and performance of alternative carbon capture and sequestration technologies for fossil-fueled power plants. The model calculates emissions, costs, and efficiency on a systematic basis at the level of an individual plant or facility. Both new and existing facilities can be modeled, including coal-based or natural gas-based combustion or gasification systems using air or oxygen. CO₂ storage options include various types of geologic formations, as well as ocean and terrestrial sinks. A key feature of the integrated modeling framework is the explicit characterization of uncertainties in model inputs and results using a probabilistic (stochastic simulation) capability. This capability provides quantitative estimates of the technological and economic risks associated with alternative CO₂ capture and sequestration technologies. This paper reviews the goals and scope of this project and presents preliminary results for the case of carbon capture from coal combustion.

INTRODUCTION

The control of greenhouse gas emissions is arguably the most challenging environmental policy issue facing the U.S. and other industrialized nations. A mitigation approach that is gaining widespread interest is to capture and sequester the CO₂ emitted from fossil-fuel combustion sources [1,2]. The key attraction of this option is that it could allow fossil fuels to continue to be used without significantly contributing to greenhouse warming. This would be a radical departure from conventional thinking about climate mitigation, which requires abandoning or limiting fossil fuel use to a high degree. At the present time, however, CO₂ capture is much more costly than other near term options for greenhouse gas reductions. New R&D efforts thus have the goal of significantly reducing the cost of CO₂ capture and sequestration [3]. Electric power plants — especially coal-based plants, which contribute about 30% of the U.S. CO₂ emissions — are the principal targets for this type of CO₂ control technology [4, 5].

Technology Options for CO₂ Capture

A wide range of technologies currently exists for separation and capture of CO₂ from gas streams (see Figure 1). In general, these processes have been designed and used for industrial applications at a much smaller scale than power plant operations [6]. Current commercial processes employ a variety of physical and chemical mechanisms including absorption, adsorption, membranes and cryogenics [7-11]. The choice of a suitable technology depends upon the characteristics of the CO₂-laden gas stream, which in turn

depends mainly on the type of power plant technology. Figure 2 shows the different types of fossil fuel power plants and technologies that affect the choice of a CO₂ capture system. Future coal-based plants may be designed to separate and capture CO₂ prior to combustion (using coal gasification systems), or they might employ pure oxygen combustion instead of air so as to obtain a concentrated CO₂ stream for treatment. Plants fueled by natural gas similarly have options to capture CO₂ either before (via gas reforming) or after combustion.

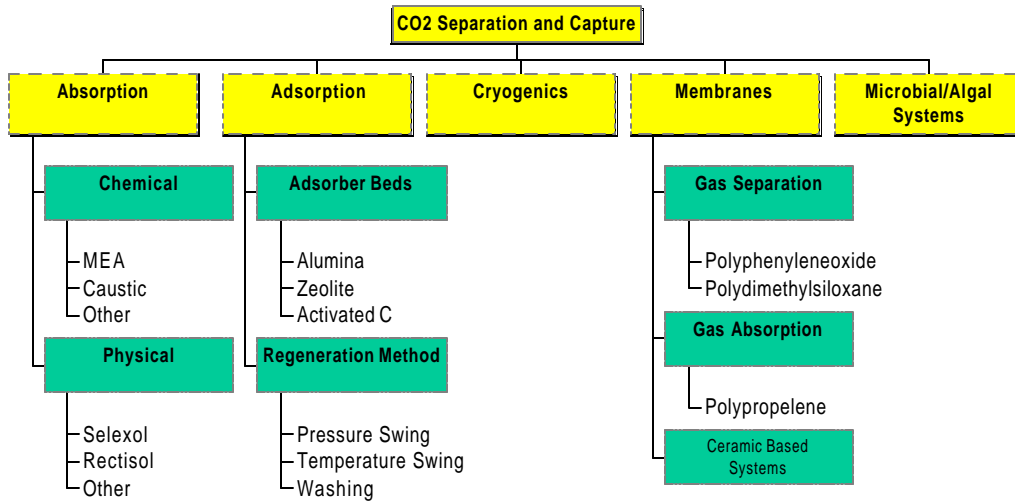

Figure 1. Technology Options for CO₂ Separation and Capture

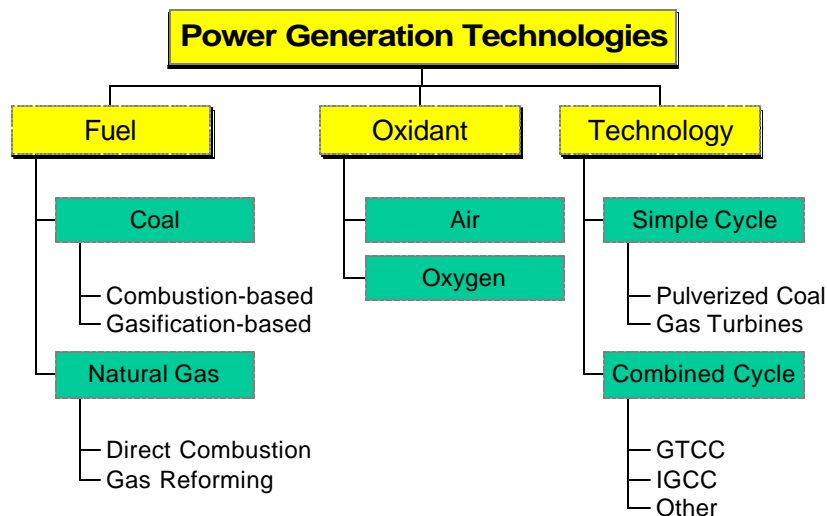

Figure 2. Technology Options for Fossil-Fuel based Power Generation

Options for CO₂ Sequestration

Once the CO₂ is captured, it must be securely stored (sequestered). Again, there is a range of options potentially available (see Figure 3). Geologic formations such as deep saline reservoirs, depleted oil and gas wells, and abandoned coal seams are some of the potentially attractive disposal sites [12-15]. Ocean disposal and terrestrial sinks are additional options being studied [16-17]. The distance to a secure storage site and the availability and cost of transportation infrastructure also affect the choice of disposal option. While the economic costs of CO₂ storage appear to be low compared to the cost of CO₂ capture, the social and political acceptability of CO₂ sequestration options are not yet certain.

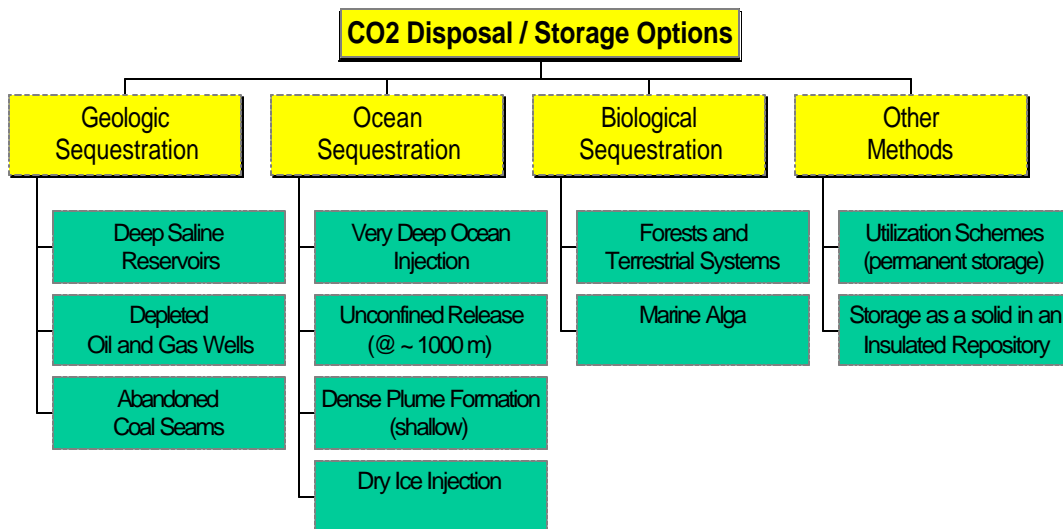

Figure 3. Potential Options for CO₂ Sequestration

MODELING AND ASSESSMENT NEEDS

The Carbon Sequestration Program of DOE's National Energy Technology Laboratory (NETL) has the goal of developing safe, lower-cost methods of carbon capture and sequestration as a potential future option for greenhouse gas mitigation. One element of this program involves the development of modeling and assessments tools to evaluate and compare the overall effectiveness, costs, and sequestration potential of alternative carbon management methods. Tools also are needed to help identify and prioritize the most promising R&D efforts.

Scope and Goals of This Project

The project described in this paper was among the first set of projects selected by DOE/NETL under the Carbon Sequestration Program. Its goal is to support modeling and assessment activities by developing a systematic framework for characterizing the performance and cost of alternative carbon capture and sequestration technologies. This framework will include the broad range of electric power systems depicted in Figure 2, and an associated set of carbon capture and sequestration technologies drawn from the

categories shown in Figures 1 and 3. Of particular interest is the ability to assess realistically the potential merits of advanced technologies relative to current commercial systems (which also continue to evolve). Because electric power plants also must control emissions of criteria air pollutants, hazardous pollutants, water pollutants, and solid wastes, a multi-pollutant framework for evaluating CO₂ control options is important. So too is the ability to characterize the technical and economic uncertainties for a particular technology, especially for new or developing systems that are not yet commercial.

A Hierarchy of Modeling Tools and Capabilities

No single analytical tool or model can adequately serve all of the needs for modeling and assessments. Rather, a variety of models and methods are required to appropriately address different types of questions. The modeling effort described in this paper provides estimates of technology cost, emissions and performance at the level of an individual plant or facility. These models are appropriate for scoping studies, preliminary design, and comparative assessments of alternative technologies. They have modest site-specific data requirements, and are able to run quickly and inexpensively to address a wide variety of “what if” questions related to multi-pollutant emissions control, including carbon sequestration options. Other types of modeling tools are needed for large-scale assessments and policy analyses that require the capability to represent complex couplings and interactions within a regional, national or global setting, or to assess the environmental consequences of a proposed policy measure.

Ideally, different types of models and assessment tools can draw upon one another in an overall hierarchy of capabilities. Thus, the plant-level model discussed in this paper incorporates results from more detailed design studies and models, and in turn can provide inputs to larger-scale assessment models to address a broader set of questions.

MODELING APPROACH

The modeling framework adopted for the current project is based on the Integrated Environmental Control Model (IECM) developed for DOE/NETL under a prior research contract. The IECM provides plant-level performance, emissions and cost estimates for a variety of environmental control options for coal-fired power plants. It is built in a modular fashion that allows models of new technologies to be easily incorporated into the overall framework. A user can then select different technology options to configure and evaluate a particular power plant design. Current environmental control options include a variety of conventional and advanced systems for controlling SO₂, NO_x, particulates and mercury emissions for both new and retrofit applications. This general modeling framework now is being expanded to incorporate a broad array of power generating systems (Figure 2) and carbon management options. Key features of the modeling framework are highlighted below.

Technology Performance Models

The building blocks of the IECM are a set of performance and cost models for individual technologies that can be linked together to configure a user-specified power

generating system. The process performance models employ mass and energy balances to quantify all system mass flows including environmental emissions. The energy requirements of each technology also are modeled and used to calculate the net efficiency of the overall plant. Details of current models can be found in published papers and reports [18,19] and the software can be freely downloaded [20]. Typically, each process performance model has approximately 10 to 20 key input parameters, depending upon the complexity and maturity of the technology.

Technology Cost Models

For each technology module in the IECM, associated cost models are developed for total capital cost, variable operating costs, and fixed operating costs. These elements are combined to calculate a total annualized cost based on a consistent set of user-specified financial and lifetime assumptions. Normalized cost results, such as costs per kilowatt (or kilowatt-hour) of net capacity, and the cost per ton of pollutant removed or avoided, also are calculated. Cost models typically have about 20 to 30 parameters per technology, including all indirect cost factors and unit costs.

An important feature of the cost models is that they are explicitly coupled to the process performance models. Thus, capital costs depend on key flowsheet variables such as mass or volumetric flow rates, and important thermodynamic variables such as temperature or pressure. Annual operating and maintenance (O&M) costs also are linked to mass and energy flows derived from the process performance model.

Characterization of Uncertainties

An important feature of the IECM is the capability to rigorously characterize and analyze uncertainties. In addition to conventional deterministic (single-valued) calculations, the IECM allows any or all model input parameters and output results to be quantified probabilistically. This allows the interactive effects of uncertainties in many different parameters to be considered simultaneously.

Stochastic analysis thus provides quantitative insights about the *likelihood* of various outcomes, allowing users to more rigorously address questions such as:

- What is the likely cost savings of a proposed new process design relative to current technology? What are the potential risks (e.g., shortfalls in performance, or overruns in cost)?
- Which sequestration methods and technologies appear most promising for further development? Are there particular markets or applications that are likely to be most attractive?
- Which parameters contribute most to overall uncertainty in performance and cost? What are the potential payoffs from targeted research and development to reduce key uncertainties?

The stochastic simulation capability also allows users to compare the results of different model runs involving different technology choices (e.g. a proposed new technology

versus an existing baseline system). Displaying the differences between two systems on a probabilistic basis, as illustrated in Figure 4, can be especially useful for assessing the risks and potential payoffs of R&D investments in new technology.

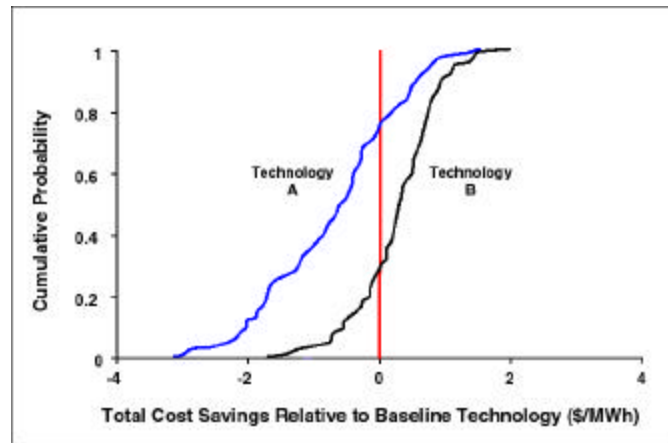

Figure 4. Probability of a Cost Savings from an Advanced Technology

Multi-Pollutant Emissions Accounting

The modeling framework accounts not only for CO₂ emissions but also for criteria air pollutants (SO₂, NO_x, and particulates), major air toxics (especially mercury), and all system solid wastes or byproducts. Accounting for multi-pollutant emissions is important for assessing the overall environmental benefits of carbon capture and sequestration technology, and for insuring that carbon management systems do not inadvertently cause or aggregate other environmental problems.

User-Friendly Operation

The IECM was designed to provide sophisticated modeling capabilities with quick turn-around time (seconds per run), transparency, and ease of use. A newly-designed graphical interface provides the capability to configure an analysis, set key parameter values (and their uncertainties), and get results in either probabilistic or deterministic form. A variety of graphical, pictorial, and tabular reports are available via the interface.

Figure 5 shows several screen shots from the IECM's graphical user interface. In the current project the user interface is being expanded to include the full set of power generation options in Figure 2, plus a variety of current and advanced options for CO₂ capture, transport and storage.

INITIAL MODEL DEVELOPMENT

The first phase of this project is focused on modeling a set of current commercial power systems and carbon capture technologies that can serve as a baseline or reference design for comparisons (later in the project) with new or improved systems.

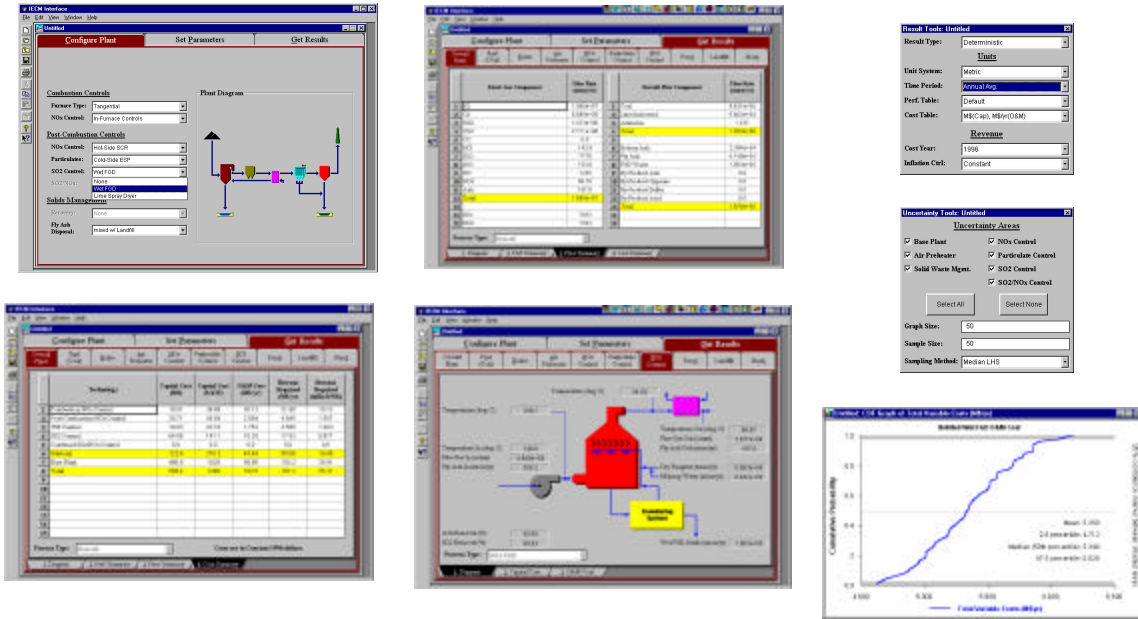

Figure 5. Sample Screens from the Current IECM Graphical User Interface

Because coal is the dominant fuel for power generation, we have focused initially on coal combustion systems. Today, 300 GW of coal-fired capacity in the U.S. provides 51% of all power generation and accounts for 79% of all carbon emissions from electric utilities. Even with the expected growth in natural gas for new generating capacity, coal's share of U.S. electricity supply is still projected to be about 44% in 2020, and higher in absolute amount compared to today [21]. Thus, any policies to substantially reduce CO₂ emissions during the next two decades must consider not only the technology options for new power plants (which is the case most commonly discussed in the literature), but also the possible retrofitting of existing coal plants, many of which will continue to operate for several decades to come. Thus, our first case involves post-combustion carbon capture for a pulverized coal (PC) power plant.

Model of an Amine-Based Capture System

Past studies have shown that amine-based CO₂ absorption systems are the most suitable technology for combustion-based power plants. These systems can capture up to about 90% CO₂ to yield a nearly pure (>99%) CO₂ product stream. This class of solvents is based on monoethanolamine (MEA), an organic chemical developed over 60 years ago as a general, non-selective solvent to remove acidic gas impurities (e.g. H₂S, CO₂) from natural gas streams [22]. The process was then adapted to treat flue gas streams for CO₂ capture. Fluor Daniel Inc., Dow Chemical Co., Kerr-McGee Chemical Corp. and ABB Lummus Crest Inc., were some of the initial developers of this technology. Continued development is proceeding in Canada, Japan, the U.S. and elsewhere.

A preliminary model has been developed to simulate the performance and cost of a CO₂ capture system based on amine (MEA) scrubbing. The process consists of two main

elements: an absorber, where CO₂ is separated from the flue gas stream and absorbed by the MEA-based solvent; and a regenerator (or stripper), where the solvent is heated to release the CO₂ (in concentrated form) to recover the original solvent. The heat required to regenerate the solvent represents a significant energy penalty for the system. The current model default assumes that heat for solvent regeneration is derived from low-pressure steam available within the power plant. Substantial energy also is needed to compress and liquefy the captured CO₂ for pipeline transport to a storage site. Additional electrical energy is required for solvent circulation, flue gas fans and other system requirements.

Table 1 lists the preliminary set of performance model parameters for the amine-based (MEA) systems. Key outputs of the performance model include the quantities of CO₂ and other flue gas constituents removed by the solvent (mainly acid gases such as SO₂ and NO₂); total sorbent (MEA) requirements (including amounts of makeup sorbent and non-regenerable spent sorbent); the product gas composition; CO₂ product flow rate; and the system energy requirements.

Table 1. Amine System Performance Model Parameters (Preliminary)

Parameter	Units
CO ₂ removal efficiency	%
SO ₂ removal efficiency	%
NO ₂ removal efficiency	%
PM removal efficiency	%
MEA concentration	wt %
Maximum CO ₂ loading	mol CO ₂ /mol MEA
Lean solvent CO ₂ loading	mol CO ₂ /mol MEA
Nominal MEA make-up	kg MEA/ton CO ₂
MEA loss for SO ₂	mol MEA/ mol SO ₂
MEA loss for NO ₂	mol MEA/ mol NO ₂
MEA regeneration heat	kJ/kg CO ₂ recovered
Equiv. elec. requirement	% regeneration heat
CO ₂ product pressure	atm
CO ₂ product purity	wt %
Compressor efficiency	%
Solvent pumping head	kPa
Pump efficiency	%
Gas-phase pressure drop	kPa
Fan efficiency	%

Table 2 lists the elements of the preliminary cost model for the amine system. The general cost categories are identical to those used for other power plant components in the IECM, and are based on the EPRI nomenclature for cost accounting [23]. The costs of CO₂ transport and storage are treated as annual operating expenses whose values

reflect the amortized capital costs of pipeline construction and other activities beyond the plant gate.

Table 2. Amine System Cost Model Parameters (Preliminary)

Capital Cost Elements	O&M Cost Elements
Process Area Equipment Costs (5 process areas)	<i>Fixed O&M Costs</i>
Process Facilities Cost (PFC) = sum of above	Operating Labor
	Maintenance Labor
Engineering and Home Office	Admin. & Support Labor
General Facilities	Maintenance Materials
Process Contingency	<i>Variable O&M Costs</i>
Project Contingency	
Total Plant Cost (TPC) = sum of above	
Interest During Construction	Reagent (MEA) Cost
Royalty Fees	Waste Disposal Cost
Pre-production Costs	Water Cost
Inventory (startup) Cost	Power Cost*
Total Capital Requirement (TCR)	CO ₂ Transport Cost
	CO ₂ Storage Cost

*Reflects total process energy requirements. Cost calculated explicitly only if supplied by an external source.

Nominal values for all process performance parameters and cost parameters in the model reflect judgments based on an extensive review of the literature and discussions with several experts in the field. For many important parameters there remains considerable uncertainty and variability in published estimates, reflecting differences in design assumptions, process applications and other (often unreported) factors. We have attempted to characterize these uncertainties using probability distributions based on available data and judgments. All details of these preliminary performance and cost models will be summarized in a report currently in preparation, which will serve as a basis for review and subsequent model refinements.

Cost of CO₂ Avoided

In addition to its impact on the total cost of electricity generation at a facility, the cost of CO₂ avoidance is an economic indicator that is widely used to characterize and compare alternative CO₂ mitigation options. This value can be calculated from other normalized cost results reported by the IECM:

$$\text{Cost of CO}_2 \text{ Avoided (\$/ton)} = \frac{(\$ / MWh)_{\text{capture}} - (\$ / MWh)_{\text{reference}}}{(t \text{ CO}_2 / MWh)_{\text{reference}} - (t \text{ CO}_2 / MWh)_{\text{capture}}}$$

where, $\$/MWh$ is the cost of electricity (COE) for the overall power plant based on the *net* plant capacity after accounting for all system power requirements.

The desire to quantify control costs for a single pollutant, however, often requires a judgment as to how to charge or allocate certain costs for complex systems like power plants, which control multiple pollutants using multiple technologies that often interact with one another (e.g., SO₂ scrubbers also remove particulate matter and air toxics, while CO₂ scrubbers also remove SO₂ and some NO_x). Should credits be given for the amount of secondary pollutants removed, and if so, how much? For energy-intensive processes like amine-based CO₂ capture systems, the method used to charge or allocate the cost of steam and electricity (e.g., whether energy is supplied from within the plant or from an external source) can lead to further differences in the cost of CO₂ avoided. These are some of the many factors that influence the cost of CO₂ control, as further explored in the following section.

PRELIMINARY RESULTS

The MEA process module described above has been integrated with the IECM simulation framework to produce a model of a complete coal-fired power plant with multi-pollutant environmental controls. The reference case is a new 500 MW (gross) PC plant burning a low-sulfur western U.S. coal, and meeting current (year 2000) federal New Source Performance Standards (NSPS) for SO₂, NO_x and particulates [24]. The CO₂ capture case adds the MEA scrubber plus pipeline transport of CO₂ to an underground storage site (depleted oil reservoir) 100 km from the plant. It also upgrades the SO₂ removal efficiency of the FGD system. Table 3 lists the key plant design assumptions.* Figure 6 shows a schematic of the plant including the CO₂ capture unit.

Table 3. Design Basis for the Case Study Plant

Parameter	Value	Parameter	Value
Gross plant size (MW)	500	Emission standards	2000 NSPS ^a
Gross plant heat rate (kJ/kWh)	9767	NO _x controls	LNB ^b + SCR ^c
Annual avg. capacity factor (%)	75	Particulate control	ESP ^d
		SO ₂ control	FGD ^e
<i>Coal characteristics</i>		CO ₂ control	MEA ^f
Rank	Sub-bit.	CO ₂ capture efficiency (%)	90
HHV (MJ/kg)	19.4	CO ₂ product pressure (atm)	137
% S	0.48	Distance to storage site (km)	100
% C	47.85	<i>Financial Factors</i>	
% Ash	6.4	Cost year basis (constant dollars)	1999
Delivered cost (\$/ton)	23.19	Capital charge rate	0.15

^aNSPS = New Source Performance Standard, ^bLNB = Low-NO_x Burner, ^cSCR = Selective Catalytic Reduction, ^dESP = Electrostatic Precipitator, ^eFGD = Flue Gas Desulfurization, ^fMEA = Monoethanolamine system.

The model is run first in the deterministic mode using the nominal (default) value of each parameter. For the CO₂ capture case, we also ran a probabilistic analysis using uncertainty distributions derived from the literature review of amine-based capture

* Note: All units used in this paper are in the SI (metric) system.

systems and CO₂ transport/storage options. These distributions reflect both uncertainty and variability for system designs similar to the one modeled here.

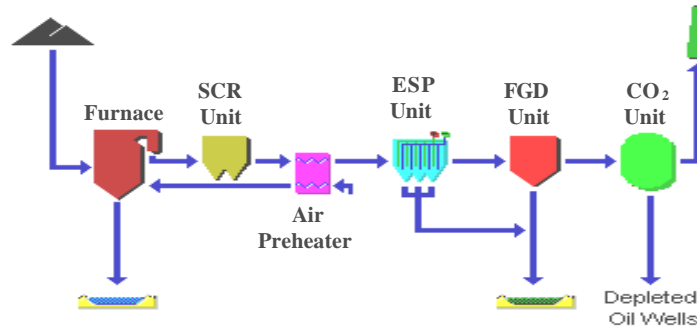

Figure 6. Configuration of the Case Study Plant with CO₂ Capture

Performance Results

Table 4 shows the effects of the carbon capture system on the net plant capacity and emissions of CO₂ and criteria air pollutants (SO₂ and NO_x), based on the deterministic results. Annual mass emissions of CO₂ are reduced by 90 percent, or 2.62 Mtons/yr, which is the amount sequestered in this case. On a normalized basis (per net kilowatt-hour generated) this reduction is 87 percent because of the loss of net plant capacity needed to run the CO₂ control system. SO₂ emissions also are reduced significantly by addition of the CO₂ capture system. On the other hand, annual emissions of NO_x decline only slightly on an absolute basis (because the amine scrubber does not capture nitric oxide, which is the prevalent component of NO_x), but the emission rate *increases* when normalized on net generation. This again is because of the substantial loss of net capacity due to the CO₂ controls.

Table 4. Emissions from Case Study Plants

Parameter	Units	Reference Plant	w/ CO ₂ Capture
Net plant capacity	MW (net)	456	358
CO ₂ emitted	tons CO ₂ /year	2.91 million	0.29 million
SO ₂ emitted	tons SO ₂ /year	7500	14
NO _x emitted	tons NO _x /year	1390	1290
CO ₂ emission rate	g CO ₂ / kWh (net)	971	124
SO ₂ emission rate	g SO ₂ / kWh (net)	2.50	0.006
NO _x emission rate	g NO _x / kWh (net)	0.46	0.55

Cost Results

To illustrate the preliminary cost results we select the cost of avoided CO₂ emissions as a measure of interest. Figure 7 shows the deterministic value for this case to be \$57/ ton of CO₂ avoided (relative to the reference plant without carbon capture). This value includes the cost of upgrading the FGD system to 98 percent SO₂ removal in the carbon capture case (versus 70 percent in the reference case) in order to minimize the overall cost of electricity for the plant (and hence the cost of CO₂ avoided). In this example, no cost credit has been taken for the additional sulfur removed, and the combined cost of CO₂ transport and sequestration is assumed to be \$7/ton of CO₂ captured.

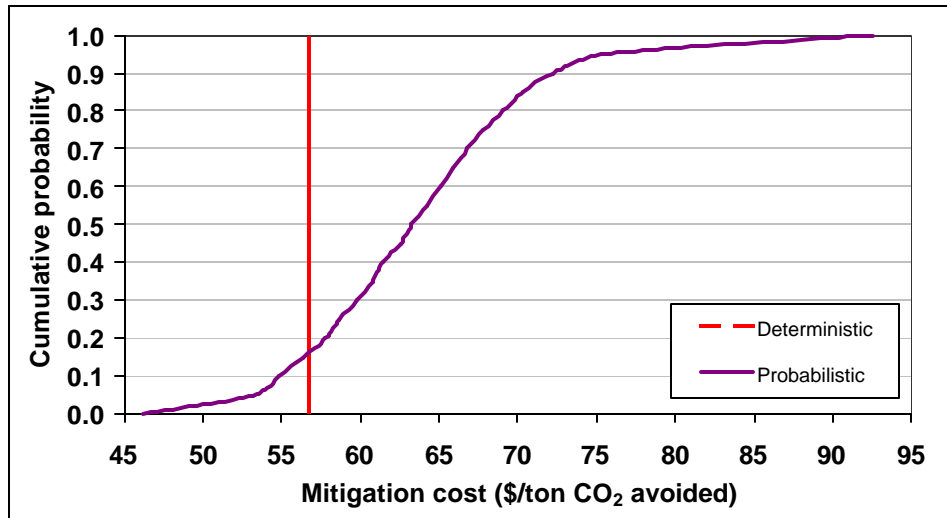

Figure 7. Preliminary Results for CO₂ Mitigation Cost

The effect of uncertainties in performance and cost parameters for the CO₂ capture case also is shown in Figure 7. The probabilistic result represents the combined influence of uncertainties and variability in 31 independent model parameters (17 performance parameters and 14 cost parameters). The cost of CO₂ avoidance is now found to have a much wider range (approximately \$46 to \$93/ton CO₂ avoided), with a higher mean value (\$65/ton) than the deterministic result. While many factors contribute to this outcome, the key uncertainties are those related to process performance, especially the thermal and electrical energy required for sorbent regeneration and CO₂ compression.

Uncertainties in the costs of CO₂ transport and storage also play an important role in overall process economics. In the example above we assumed that cost of sequestration in a depleted underground oil reservoir had a nominal cost of \$5/ton with a range from \$1 to \$12/ton CO₂ stored (in addition to the cost of pipeline transport). But in cases where the captured CO₂ can be used for enhanced oil recovery (EOR) the CO₂ may instead generate an income stream. We modeled this case as a separate sensitivity study with the results shown in Figure 8. In this case we assumed a cost credit (negative disposal cost) of \$10/ton with a range of \$5 to \$15/ton based on published estimates.

The effect of this change is to shift the original distribution function toward the left, reducing the cost of CO₂ avoided by roughly \$21/ton. Overall, then, Figure 8 shows that any point value estimate of CO₂ mitigation cost depends strongly on the detailed assumptions underlying the analysis, and cannot readily be generalized. Furthermore, other power plant design and financial parameters held constant in this analysis also could have a considerable effect on the cost of CO₂ control. This includes all of the parameters listed in Table 3, especially the annual average capacity factor and capital charge rate. The choice of a reference plant design also is a key determinant of the cost of CO₂ avoided, as others have pointed out in prior analyses of CO₂ mitigation costs [25,26].

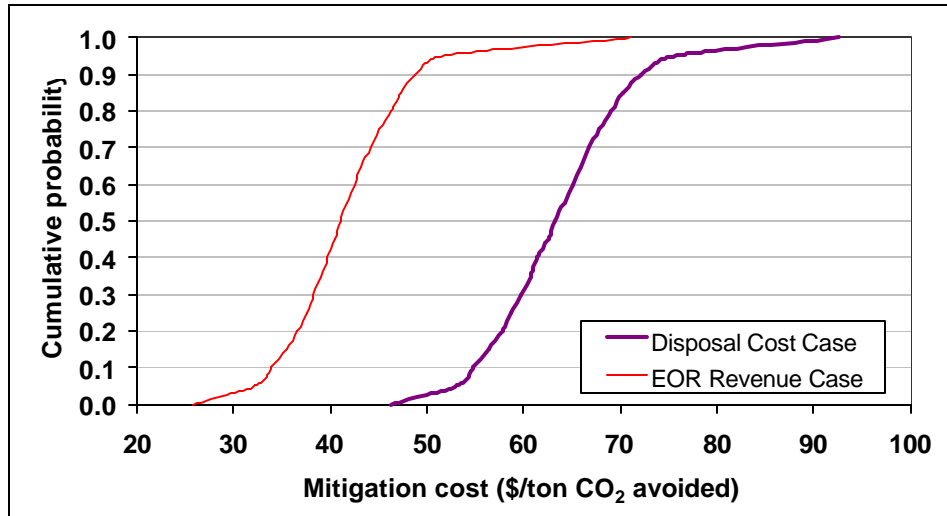

Figure 8. Effect of Storage Cost Assumptions on Cost of CO₂ Avoided

Applications to CO₂ Retrofits

As noted earlier, many existing coal-fired plants will continue to operate for several decades to come, and thus may become candidates for CO₂ retrofit controls under a sufficiently stringent climate policy. To the extent that existing capital equipment is fully amortized, the cost of electricity generated at existing plants will be significantly lower than that for the new plants modeled earlier. This will reduce the cost of operating the energy-intensive MEA system, in turn reducing the cost of CO₂ control (all else being equal). Because of multi-pollutant interactions, however, the cost of CO₂ mitigation also will be affected by emission control requirements for other pollutants, especially SO₂. At the present time, only about 30 percent of the coal-fired capacity in the U.S. uses flue gas desulfurization (FGD) for SO₂ control. Most plants comply with current regulations using low-sulfur coals. Thus, the configuration of an existing plant directly impacts the cost of CO₂ control when retrofitting a post-combustion MEA-based system to capture CO₂. This is because MEA absorbs SO₂ as well as CO₂, though at a high cost in lost solvent.

We ran several cases (Table 5) to look at multi-pollutant tradeoffs for CO₂ retrofit situations, assuming no new emission control requirements other than for CO₂. Thus, the

cost of any new sulfur removal system or FGD upgrade needed to minimize the cost of CO₂ reductions was charged to the cost of CO₂ mitigation. In these cases, however, we credited the CO₂ unit for the current market value of additional SO₂ allowances that could be generated and traded under the national acid rain control program.

Table 5. Scenarios for Retrofit Studies of an Existing 500 MW Plant

CASE	A	B	C	D
Coal Type	Low-S	Low-S	Low-S	High-S
Existing SO₂ Control	<i>None</i>	<i>None</i>	FGD (70% removal)	FGD (~90% removal)
Existing NO- Control	LNB	LNB	LNB	LNB
CO₂ Retrofit Option	MEA system	MEA system plus new FGD	MEA system plus FGD upgrade	MEA system plus FGD upgrade

Even without the SO₂ credits, preliminary results indicated that the CO₂ mitigation cost for the retrofit plant was about 5 to 15 percent lower than the costs shown earlier for a new plant. Credits for additional SO₂ reductions decreased the cost of avoided CO₂ only slightly. In all cases, overall plant costs were minimized by installing or upgrading an efficient FGD system upstream of the amine scrubber so as to minimize solvent losses from SO₂ capture by MEA. This result is consistent with another recent study of power plant retrofits at a coal-fired power plant [27].

An important caveat to these results is that many other site-specific factors, including the availability of space, and proximity to a suitable sequestration site, also affect the viability and cost of retrofitting a CO₂ capture unit. The present analysis highlights only the roles of existing environmental control system design and plant energy requirements. Because of the large energy penalty for CO₂ capture using an amine scrubber, retrofitting this technology at an existing plant results in a substantial loss of plant capacity and much higher generation costs. These factors will significantly affect future electricity demand and capacity planning, especially if this technology is widely implemented. Analysis of system-wide effects on the timing and types of new capacity additions that will be needed in a particular situation is outside the scope of the present study, but must be part of any comprehensive assessment of CO₂ capture and sequestration options.

FUTURE ACTIVITIES

Another application of the modeling framework described here will be to look at the potential for cost reductions from R&D programs that improve the performance of current carbon capture systems. This will affect both the nominal value and uncertainty (or variability) of key model performance and cost parameters in the current framework. The result will be a shift in the cost distribution function, as illustrated qualitatively in Figure 9. Future research will seek to quantify potential process improvements in more detail, and apply the current model to help assess potential R&D benefits and priorities.

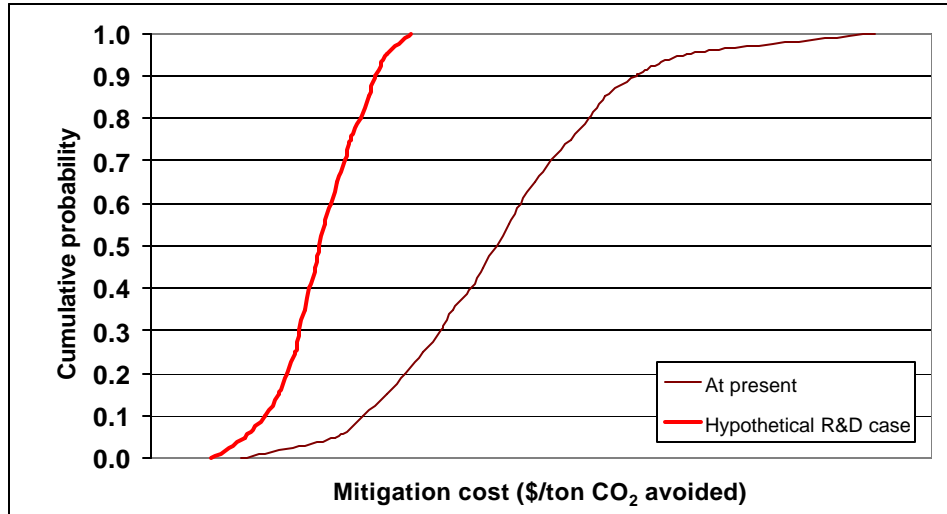

Figure 9. Illustrative Impact of a Technology R&D Program

Work currently in progress also is continuing to refine the performance and cost models described in this paper, and to extend the modeling framework to the full set of power generation and carbon capture and sequestration methods outlined earlier. Figure 10, for example, shows preliminary designs of the graphical interface accompanying new models for natural gas combined cycle systems and gasification-based options. In all cases, we will pay close attention to multi-pollutant impacts and interactions to ensure as complete an accounting as possible of all environmental emissions associated with a given plant design.

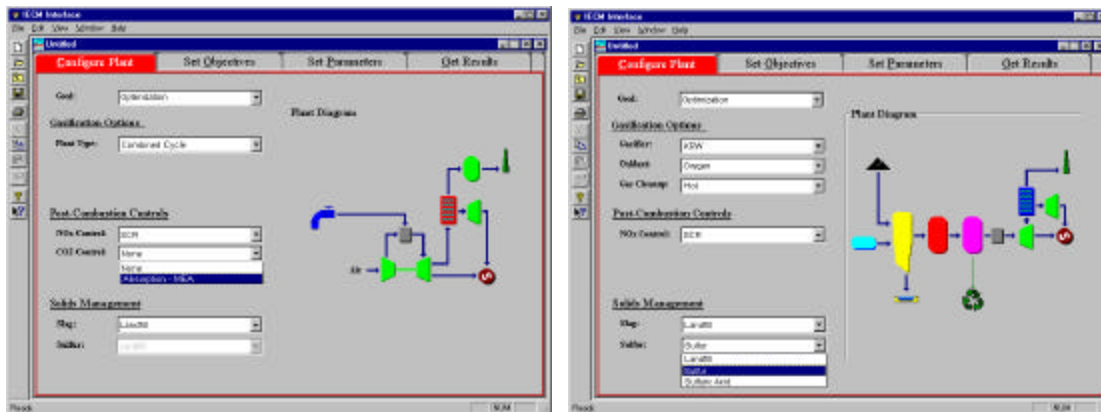

Figure 10. Illustrative Screens for Configuring New Technology Options

As the model development proceeds, we also will begin to apply this tool to help assess priorities for ongoing R&D and the potential payoffs from such efforts, as described earlier. Applications of the model to actual utility situations, in the context of multi-pollutant emissions control, also will be sought in conjunction with industrial collaborators. Regular review and critique of our efforts by an advisory group of experts and model users is another integral part of planned future activities.

REFERENCES

1. DOE (1999), "Carbon sequestration: research and development," *A U.S. Department of Energy Report*, Office of Science, Office of Fossil Energy, U.S. Department of Energy (available online at: www.ornl.gov/carbon_sequestration/).
2. Parson, E.A. and D.W. Keith (1998). "Fossil fuels without CO₂ emissions," *Science*, **282**, 1053-1054.
3. Hezorg H.J., E. Drake and E. Adams (1997). "CO₂ capture, reuse and storage technologies for mitigating global climate change," *A White Paper (Final report)*, Massachusetts Institute of Technology, Boston, MA.
4. Booras, G.S. and S.C. Smelser (1991). "An engineering and economic evaluation of CO₂ removal from fossil-fuel-fired power plants," *Energy*, **16**(11-12), 1295-1305.
5. Jacco, C.M.F., Hendriks, C.A. and K. Blok (1995). "Carbon dioxide recovery from industrial processes," *Climatic Change*, **29**(4), 439-461.
6. Desideri U. and R. Corbelli (1998). "CO₂ capture in small size cogeneration plants: Technical and economical considerations," *Energy Conversion and Management*, **39**(9), 857-867.
7. Riemer, P., Audus, H. and A. Smith. (1993), "Carbon dioxide capture from power stations," *a report published by IEA Greenhouse Gas R&D Programme*, Stoke Orchard, Cheltenham, UK.
8. Hendriks, C. (1994). *Carbon Dioxide Removal from Coal-fired Power Plants*, 14-223, Kluwer Academic Publishers.
9. Mimura, T., Satsumi, S., Iijima, M. and S. Mitsuoka (1999). "Developments on energy saving technology for flue gas carbon dioxide recovery by the chemical absorption method and steam system in power plant," in *Greenhouse Gas Control Technologies (ed. by Eliasson B., Riemer P. and A. Wokaun)*, *Proceedings of the 4th International Conference on Greenhouse Gas Control Technologies, 30 August – 2 September 1998, Interlaken, Switzerland*, Elsevier Science Ltd.
10. Jeremy D. (2000), *Economic Evaluation of Leading Technology Options for Sequestration of Carbon Dioxide*, M.S. Thesis, Massachusetts Institute of Technology, Boston, MA.
11. Audus, H. (2000). "Leading options for the capture of CO₂ at power stations," presented at the *Fifth International Conference on Greenhouse Gas Control Technologies*, 13 – 16 August 2000, Cairns, Australia.
12. Adams, D., Ormerod, W., Riemer, P. and A. Smith (1993). "Carbon dioxide disposal form power stations," *a report published by IEA Greenhouse Gas R&D Programme*, Stoke Orchard, Cheltenham, UK.
13. Byrer, C.W., and H.D. Guthrie (1998). "Coal deposits: potential geological sink for sequestering carbon dioxide emissions from power plants," *Proceedings of the AWMA's Second International Specialty Conference, Oct 13-15, 1998, Washington, DC*.

14. Lindeberg, E. and S. Holloway (1999). "The next steps in geo-storage of carbon dioxide," in *Greenhouse Gas Control Technologies* (ed. by Eliasson B., Riemer P. and A. Wokaun), *Proceedings of the 4th International Conference on Greenhouse Gas Control Technologies, 30 August – 2 September 1998, Interlaken, Switzerland*, Elsevier Science Ltd.
15. Bergman, P.D. and E.M. Winter (1995). "Disposal of carbon dioxide in aquifers in the U.S.," *Energy Conversion and Management*, **36**(6-9), 523-526.
16. Herzog, H.J. (1998). "Ocean sequestration of CO₂ – an overview," *Proceedings of the AWMA's Second International Specialty Conference, Oct 13-15, 1998, Washington, DC, 1998*
17. Spencer, D.F. (1999). "Integration of an advanced CO₂ separation process with methods for disposing of CO₂ in oceans and terrestrial deep aquifers," in *Greenhouse Gas Control Technologies* (ed. by Eliasson B., Riemer P. and A. Wokaun), *Proceedings of the 4th International Conference on Greenhouse Gas Control Technologies, 30 August – 2 September 1998, Interlaken, Switzerland*, Elsevier Science Ltd.
18. Rubin, E.S., Kalagnanam, J.R., Frey, H.C. and M.B. Berkenpas (1997). "Integrated environmental control modeling of coal-fired power systems," *Journal Air & Waste Management Assn.*, **47**, 1180-1188.
19. Berkenpas, M.B., J.J. Fry, K. Kietzke, and E.S. Rubin (1999), *Integrated Environmental Control Model: Technical Documentation*, report under contract No. DE-AC22-92PC91346 prepared by Center for Energy and Environmental Studies, Carnegie Mellon University, Pittsburgh, PA, for U.S. Department of Energy, Pittsburgh, PA.
20. <ftp.fetc.doe.gov/pub/IECM/iecmpage.htm>
21. EIA (2000). Annual Energy Outlook 2001 (with Projections to 2020), *A Report published by Energy Information Administration*, U.S. Department of Energy, Washington, DC.
22. Herzog, H.J. (1999). "The economics of CO₂ capture," in *Greenhouse Gas Control Technologies* (ed. by Eliasson B., Riemer P. and A. Wokaun), *Proceedings of the 4th International Conference on Greenhouse Gas Control Technologies, 30 August – 2 September 1998, Interlaken, Switzerland*, Elsevier Science Ltd., 1999, 101-106.
23. TAG (1993). *Technical Assessment Guide*, EPRI TR 102276, EPRI, Palo Alto, CA.
24. CFR (1999). Code of federal regulations, *Federal Register*, July 1, 1999, 40CFR, Ch.I.
25. Herzog, H.J. (1999), "The Economics of CO₂ Capture," *Proc. of 4th Int'l. Greenhouse Gas Control Technologies*, Elsevier Science Ltd.
26. Simbeck, D (1999), "A Portfolio Selection Approach for Power Plant CO₂ Capture, Separation and R&D Options," *Proc. of 4th Int'l. Greenhouse Gas Control Technologies*, Elsevier Science Ltd.

27. Simbeck, D. R. and M. McDonald (2000). "Existing coal power plant retrofit CO₂ control options analysis," presented at the *Fifth International Conference on Greenhouse Gas Control Technologies*, 13 – 16 August 2000, Cairns, Australia.