

Protocols for the analysis of algal samples collected as part of the U.S. Geological Survey National Water-Quality Assessment program

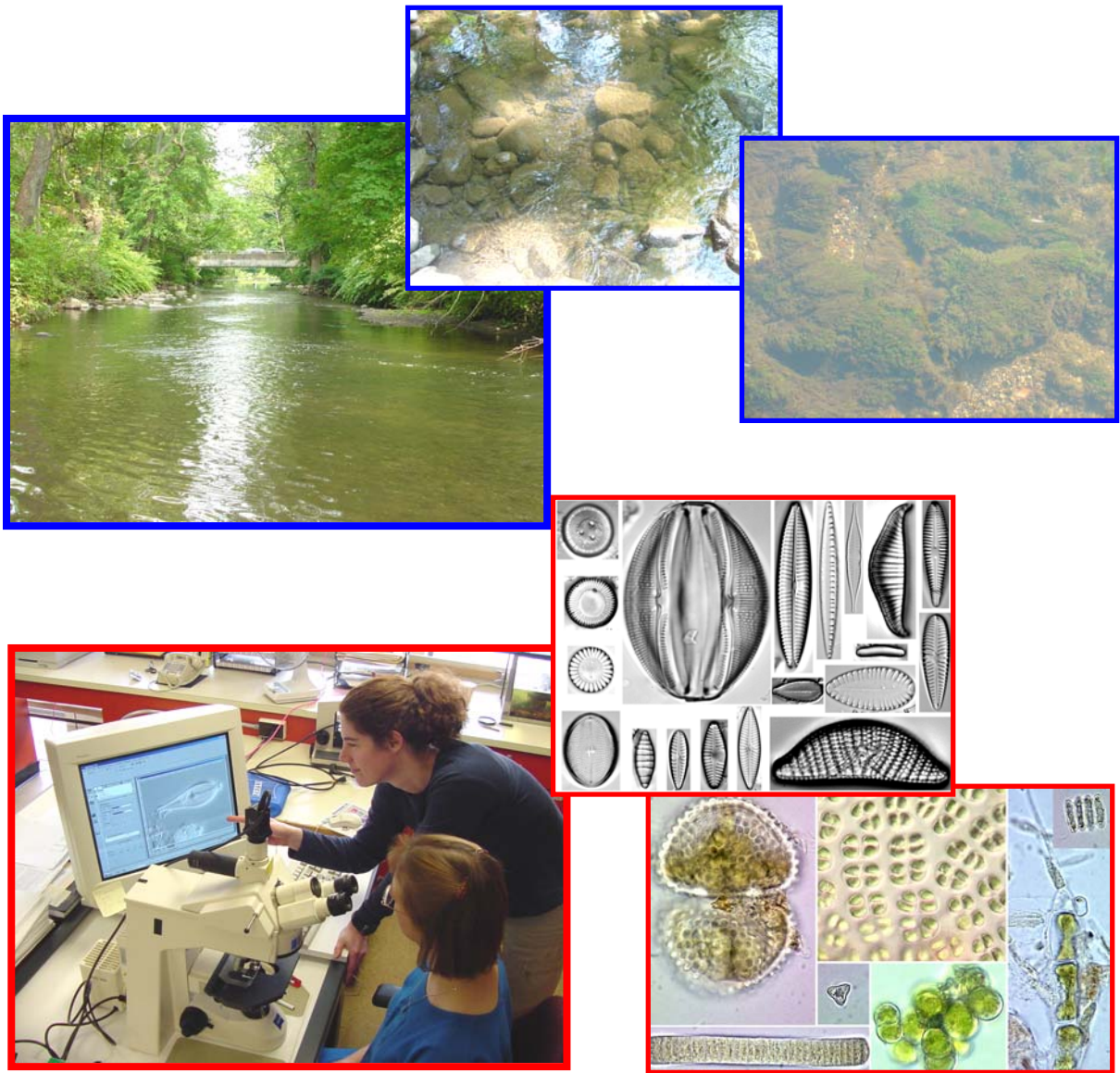

Protocols for the analysis of algal samples collected as part of the U.S. Geological Survey National Water-Quality Assessment Program

Report No. 02-06

The Academy of Natural Sciences

Patrick Center for Environmental Research–Phycology Section

1900 Benjamin Franklin Parkway

Philadelphia, PA 19103-1195

www.acnatsci.org

215/299-1000

Edited by

Donald F. Charles, Candia Knowles, and Robin S. Davis

May 2002

The Academy of Natural Sciences, an international museum of natural history operating since 1812, undertakes research and public education that focus on the environment and its diverse species.

Our mission is to expand knowledge of nature through discovery and to inspire stewardship of the environment.

TABLE OF CONTENTS

	<u>Page</u>
Acronyms	ii
Introduction	iii
Protocols	1
P-13-47: Log-in Procedures for USGS NAWQA Program Algal Samples	3
P-13-58: Tracking of Algal Sample Analysis	13
P-13-48: Subsampling Procedures for USGS NAWQA Program Periphyton Samples	17
P-13-42: Diatom Cleaning by Nitric Acid Digestion with a Microwave Apparatus	27
P-13-49: Preparation of Diatom Slides Using Naphrax™ Mounting Medium	41
P-13-50: Preparation of Algal Samples for Analysis Using Palmer-Maloney Cells	55
P-13-39: Analysis of Diatoms on Microscope Slides Prepared From USGS NAWQA Program Algae Samples	61
P-13-51: Analysis of Soft Algae in USGS NAWQA Program Qualitative Multihabitat (QMH) Samples	73
P-13-63: Analysis of Soft Algae and Enumeration of Total Number of Diatoms in USGS NAWQA Program Quantitative Targeted-Habitat (RTH and DTH) Samples	79
P-13-52: Analysis of USGS NAWQA Program Phytoplankton Samples	87
P-13-53: Preparation of Algal Data Files and Reports for Submission to the USGS NAWQA Program	97
P-13-55: Electronic Transmission of Data Files to the USGS NAWQA Program	103
P-13-56: Archiving Algal Samples, Diatom Slides and Images	107
P-13-57: Care and Maintenance of Phycology Section Equipment	117
P-13-59: Reporting of Non-conformance Issues and Corrective Action	119
P-13-62: Chemical Hygiene Practices Used in Phycology Section Laboratories	123

ACRONYMS

ANSP	The Academy of Natural Sciences of Philadelphia
APHA	American Public Health Association
ASR	Analytical Services Request
AWWA	American Water Works Association
BIO-TDB	Biological Transactional Database
CAR	Corrective Action Report
DCF	Dilution/Concentration Factor
DHDB	Diatom Herbarium Database
DIC	Differential Interference Contrast
DTH	Depositional Targeted Habitat
DW	Distilled Water
EPA	Environmental Protection Agency
FTP	File Transfer Protocol
ID	Identification
MSDS	Material Safety Data Sheet
NADED	North American Diatom Ecological Database
NAWQA	National Water-Quality Assessment
PC	Personal Computer
PCER	Patrick Center for Environmental Research
PIMS	Phycology Information Management System
PP	Phytoplankton
PPE	Personal Protective Equipment
PS	Phycology Section
PSI	Pounds per Square Inch
QA	Quality Assurance
QAM	Quality Assurance Manager
QAU	Quality Assurance Unit
QC	Quality Control
QMH	Qualitative Multihabitat
RO	Reverse Osmosis
RTH	Richest Targeted Habitat
SOP	Standard Operating Procedure
USGS	United States Geological Survey
WEF	Water Environment Federation
WPCF	Water Pollution Control Federation

INTRODUCTION

These protocols describe procedures for laboratory analysis of algae samples collected by the U.S. Geological Survey National Water-Quality Assessment Program (NAWQA) (<http://water.usgs.gov/nawqa/>). They are used by staff in the Phycology Section (PS) of the Patrick Center for Environmental Research (PCER) at The Academy of Natural Sciences in Philadelphia (ANSP), and subcontractors. Nearly all procedures have been in use since 1998, and many since 1995 when ANSP began analyzing NAWQA samples. They cover all steps in analysis, from receipt and log-in of samples at ANSP, to final transmission of data to NAWQA.

Algal samples are analyzed as part of a Cooperative Agreement between ANSP and the USGS. The overall objective of research performed under this agreement is to evaluate water quality using data on algae samples collected from rivers throughout the U.S. Roles of the ANSP include analysis of samples, ecological synthesis of data at the national scale, and development of new approaches for using algae as water quality indicators. This cooperative research effort is intended to benefit the public through the availability of a national database of algal data, and the publication of USGS reports and scientific journal articles.

These protocols apply to the analysis of the four kinds of algal samples collected by the NAWQA program: three types of periphyton samples, two quantitative and one qualitative, and phytoplankton samples (Porter et al. 1993; Moulton et al. 2002). Each is a composite sample collected from a defined sampling reach. The two quantitative periphyton sample types are Richest Targeted Habitat (RTH) and Depositional Targeted Habitat (DTH). The RTH samples are collected from the most common hard substrate, usually rocks or wood. The DTH samples are taken from sand/silt depositional areas, usually pools or areas with slow current. Protocols for analysis of quantitative samples are designed to provide data on algal densities (as cells per cm² of sampling surface) and amount of algal biovolume (μm^3 per cm² of sampling surface) at a sampling site. Qualitative Multihabitat (QMH) samples are a composite collection of algae from the majority of individual micro-habitats in the sampling reach.

Individual protocols were written and reviewed by staff who perform the analyses and are in the format specified by the PCER Quality Assurance Unit (QAU). This format requires that each protocol be understandable and usable by itself (independently), in conjunction with listed references. Many protocols pertain to samples analyzed for all Phycology Section projects; most precede NAWQA. Some apply specifically to NAWQA sample analysis and contain the phrase "USGS NAWQA Program" in their title. All protocols have been reviewed and approved by the ANSP Quality Assurance Manager (QAM).

Data needs of the NAWQA program change as the program progresses, requiring modifications to these procedures. All deviations in protocols are noted in field and/or laboratory notebooks at the time of the deviation, or at the time deviations are realized. If the deviation is such that the quality or integrity of the study is affected, the Phycology Section Laboratory Manager is informed immediately. Minor modifications of project protocols are sometimes necessary. Minor changes are noted in the margin of a laboratory copy of each protocol, initialed and dated. This may be done by the Principal Investigator, the Phycology Section Laboratory Manager or the staff member responsible for performing the procedures outlined in the protocol. All such notes are also entered into the master copy and a copy sent to the QAM. Major modifications require a formal revision of protocols. Formal revisions are reviewed by the Phycology Section Leader and the Phycology Section Project Manager and must be approved by the QAM. This approval process ensures that

work performed using these protocols is in compliance with the standards set by the Quality Assurance Unit and thereby produce credible data.

The references in each protocol are often not cited in the text. They are included to provide additional resources for users to help them better understand the background of protocols and how to implement them.

Computer Applications and Databases

Most protocols make use of specially designed computer applications, and nearly all protocols require addition of data to one of the Phycology Section Microsoft Access databases. All databases are on an Academy server and available to staff at their work stations via the Academy's computer network. All databases are backed-up daily by the Academy's Information Technology staff. The PHYCLGY database is the primary system for entering, reviewing and retrieving data related to routine laboratory operations. It is accessed primarily through its "Phycology Information Management System (PIMS)" interface. The NAWQAdat database contains data and working files that pertain only to the NAWQA project. NAWQAApp contains an application for downloading of sample identification data (Analytical Service Request, ASR) from the NAWQA BioTDB database. The North American Diatom Ecological Database (NADED) is primarily an archival database for all Phycology Section projects. NADEDdat is where data identifying samples and sites, and all algal count result and taxonomic data are stored. NADEDapp contains many applications for entry, management and analysis of data in NADED. "Tabulator" is a stand-alone program used by algal analysts to record data when making counts. "BioTDB Export" is an application used by data managers to prepare data to load into the USGS BioTDB database. Its functions include the abilities to aggregate data, ensure taxonomic consistency, and perform the "biovolume per area" calculations. All paper forms and other records are stored in a set of three folders that accompany each group of samples: "Sample Tracking and Subsampling," "Diatom Analysis," and "Soft-Algae Analysis."

Acknowledgments

The authors and editors thank the following ANSP Phycology and Support Section staff for their considerable assistance in the review and revision of these protocols: Frank Acker, Heidi Brabazon, Todd Clason, Erin Hagan, Lont Marr, Eduardo Morales, Karin Ponader, Marina Potapova, Mark Schadler, Benjamin Russell, Kathleen Sprouffske, and Diane Winter. Kalina Manoylov (Michigan State University) and Carol Couch and Stephen Moulton (NAWQA Ecological Synthesis Team) also provided many helpful comments. Eduardo Morales designed the cover. The NAWQA program funded publication of these protocols. It also has the responsibility for disseminating algal data to the public.

References

- Porter, S.D., T.F. Cuffney, M.E. Gurtz, M.R. Meador. 1993. Methods for collecting algal samples as part of the National Water-Quality Assessment program. U.S. Geological Survey Open-File Report 93-409, Raleigh, NC [39 pp] <http://water.usgs.gov/nawqa/protocols/OFR-93-409/alg1.html>
- Moulton, S.R., II, J.G. Kennen, R.M. Goldstein, J.A. Hambrook. 2002. Revised protocols for sampling algal, invertebrate, and fish communities in the National Water-Quality Assessment program, U.S. Geological Survey Open-File Report 02-150. In Press.

PROTOCOLS

Protocol P-13-47

Log-in Procedures for USGS NAWQA Program Algal Samples

Frank Acker, Candia Knowles and Kathleen Sprouffske

1. PURPOSE

1.1. The U.S. Geological Survey's (USGS) National Water-Quality Assessment Program (NAWQA) collects four kinds of algal samples that are analyzed by the Phycology Section of the Patrick Center for Environmental Research (PCER) of the Academy of Natural Sciences of Philadelphia (ANSP). These are the Qualitative Multihabitat (QMH), Richest Targeted Habitat (RTH), Depositional Targeted Habitat (DTH) and phytoplankton (PP) samples (Porter et al. 1993, Porter 1994). In addition, associated collection data (e.g., site location, date, etc.) are provided for each set of samples. This protocol describes procedures to log-in samples when they are received by the PCER Phycology Section.

2. SCOPE

- 2.1. These procedures are applicable to log-in of NAWQA algal collections and cover the steps from the receipt of samples to the subsampling and initial sample preparation procedures. Log-in procedures include creation of subprojects (defined in terms of study unit, year of collection and type of sample), downloading sample and site-location data from the NAWQA BioTDB to Phycology Section databases, assignment of samples to subprojects, assignment of sample codes, sample check-in, and documentation of the log-in process. Sample check-in is the series of steps where the samples are physically checked against the downloaded data, and all discrepancies are reconciled before preparing the sample for analysis.
- 2.2. These procedures were first used to log-in samples from 1997-start study units. Log-in data for 1991-start samples were entered by hand into database tables from paper copies or from ASCII format files supplied on floppy disks. During log-in of 1994-start samples, log-in data began to be downloaded via a NAWQA FTP site.
- 2.3. Personnel responsible for these procedures include the Phycology Section Project Manager and laboratory preparation and data entry personnel.

3. REFERENCES

- 3.1. Moulton, S.R., II, J.G. Kennen, R.M. Goldstein, J.A. Hambrook. 2002. Revised protocols for sampling algal, invertebrate, and fish communities in the National Water-Quality Assessment program, U.S. Geological Survey Open-File Report 02-150. In Press.
- 3.2. PCER, ANSP. 2002. Tracking of Algal Sample Analysis. Protocol No. P-13-58.
- 3.3. Porter, S.D. 1994. Amendment to Guidance, Procedures, and Specifications for Processing NAWQA Algal Samples by Contract Laboratories.
- 3.4. Porter, S.D., T.F. Cuffney, M.E. Gurtz, M.R. Meador. 1993. Methods for collecting algal samples as part of the National Water-Quality Assessment program. U.S. Geological

Survey Open-File Report 93-409, Raleigh, NC [39 pp] <http://water.usgs.gov/nawqa/protocols/OFR-93-409/alg1.html>

- 3.5. United States Geological Survey, National Water-Quality Assessment Program. 1997. Procedures for Processing NAWQA Algal Samples. Draft Manuscript. February 1997.

4. APPARATUS/EQUIPMENT

- 4.1. Desktop computer networked to the Phycology Section databases, and access to the USGS Biological Transactional Database (BioTDB) and internet (including email) software and connections. This protocol requires the use of three Phycology Section Microsoft Access databases, "PHYCLGY," "NAWQAApp" and "NADED" (North American Diatom Ecological Database).

5. METHODS

- 5.1. **Overview.** There are five main steps in the log-in procedure: creating a subproject to define a group of samples, downloading sample data from the NAWQA BioTDB, checking-in the sample bottles, assigning samples to a subproject, and preparing folders and forms for tracking sample preparation and analysis. These procedures are performed by the Phycology Section Project Manager or someone to whom they assign the responsibility.

- 5.2. **Create a subproject to define a set of samples.** Create a subproject to which a set of samples from a NAWQA study unit will be assigned. Samples within a subproject are analyzed together and many data operations are performed on all samples grouped in a subproject.

From within the PHYCLGY database, add data to the following fields in the "Subprojects" table.

- 5.2.1. **Subproject ID.** For the NAWQA program, subprojects are defined as unique combinations of study unit, year of collection, and sometimes sample type (phytoplankton samples are often kept separate from the periphyton samples). Subproject IDs are constructed as follows: "ANSPGS" + last two digits of year samples were collected + two digits representing the chronological order in which the study unit samples arrived + two letter code representing the type of sample (PR for periphyton; PP for phytoplankton). For example, all of the periphyton samples from the Southern Florida Basins (SOFL) study unit that were collected in 1997 are assigned to the same subproject; samples from SOFL, collected in 1998, are assigned to a different subproject.
- 5.2.2. **Subproject Name.** Name includes four concatenated components: full name of NAWQA study unit + (4 letter abbreviation of study unit name + year in which samples were taken) + USGS NAWQA. Example: "Delaware River Basin (DELR2000) USGS NAWQA."
- 5.2.3. **Handle.** An eight character short name for subproject. For NAWQA subprojects, it is a concatenation of the official NAWQA four letter abbreviation of the study unit name plus the year in which samples were taken (e.g., MOBL2001).

- 5.2.4. **Is Active.** Check this box. The box will be manually un-checked when all subproject data have been transmitted to the NAWQA BioTDB.
 - 5.2.5. **Year Subproject Started.** For NAWQA, this is the year the first samples of the subproject were received at ANSP.
 - 5.2.6. **Year First Sample.** For NAWQA, this is the year the samples were collected.
 - 5.2.7. **Beginning Sample ID and Ending Sample ID.** Not applicable to NAWQA. Leave field blank.
 - 5.2.8. **Project ID.** Find in the “Projects” table in the NADEDdat or PHYCLGY databases.
- 5.3. **Download subproject sample and site information.** The USGS provides ANSP with access to the Analytical Services Request (ASR) data in its BioTDB. Follow the steps below to download the relevant data into a transitional database table at ANSP and then append them to several different tables, one subproject at a time. See Table 1 for details of the data transfers from the BioTDB through the transitional database table into the NADED database.
- 5.3.1. Use the NAWQAApp.mdb database to acquire data from the BioTDB database. After opening the NAWQAApp database, the first screen encountered is the “NAWQA Project Database” (Figure 1). Click the “NAWQA ASR Download” button to open the “NAWQA ASR Data” form (Figure 2).
 - 5.3.2. Click the Download button to download the latest ASR data for all subprojects from the BioTDB. Enter the Log-in ID and Password into the SQL Server Log-in message box that pops up. After a short wait, a message box appears with the following notification: “You are about to download x new ASR Records from the BioTDB. Continue?” Click Yes.
 - 5.3.3. Move to Tab 2, entitled “Select Study Unit” and select a study unit, begin year, and end year from the drop-down lists (Figure 3). Click the “Go” button to create a list of the samples that belong to the study unit and year identified as the selection criteria. Click the “Print Form” button to create and print a “NAWQA Algae Sample Check” form (Figure 4) to use in the sample check-in process.
- 5.4. **Check-in samples.**
- 5.4.1. Unpack the samples, inspect them, and check that the number of samples received equals the number expected. Perform these and following steps in a laboratory because they require handling samples that may contain harmful chemicals. Wearing protective gloves, a lab coat and safety goggles is recommended. Be very careful when unpacking and handling samples, especially if any appear to be leaking. If samples must be opened during this step, do so under a fume hood. Re-bottle any damaged or leaking samples; note this action on the “NAWQA Algae Sample Check” form.
 - 5.4.2. Compare the information printed on the “NAWQA Algae Sample Check” form with that printed on the sample bottle labels and the packing sheets (Bottle Shipping List) sent with the samples. Report, resolve and/or correct all discrepancies, errors and omissions between these three data sources. Note deviations in numbers on the “NAWQA Algae Sample Check” form and bring them to the attention of the Project Manager as they are encountered. If there are errors that preclude sample preparation

steps, the Project Manager or designee should contact the NAWQA study unit biologist or person who shipped the samples immediately to resolve the issue before proceeding to the next stage of sample preparation. If the errors are not critical for sample preparation (e.g., sample collection date) then sample preparation should continue. The Project Manager should take steps to resolve the discrepancies.

- 5.5. **Assign samples to subproject and add sample data to NADEDdat.** Return to the “NAWQA ASR Data” application.
 - 5.5.1. Select Tab 3, entitled “Select Records to be Analyzed” and check the boxes of the samples that were checked-in using the “NAWQA Algae Sample Check” form.
 - 5.5.2. Move to Tab 4, entitled “Assign Project/Subproject” (Figure 5) and select a project and subproject from the drop-down lists. Click the “Assign” button to associate the checked samples with the selected project and subproject.
 - 5.5.3. Move to Tab 5, entitled “Append.” Click the button “Append to NADED” to add the sample data from the BioTDB to NADED. This action causes data to be added to the appropriate NADED database tables (“Sample Identification,” Site Location,” and “Sample Volumes/Areas”). Table 1 shows all the data items that are transferred from the BioTDB to the NADED database.
- 5.6. **Enter log-in data, file forms and store samples.**
 - 5.6.1. Enter data documenting the log-in process directly into the following PHYCLGY database tables.
 - 5.6.1.1. Log-in Table. Enter data into all fields. They include information on log-in date, source of samples, person performing log-in, etc. For “Log-in ID,” assign the next number in the sequence.
 - 5.6.1.2. Sample Identification Table. For each sample logged-in, add the Log-in ID assigned above to the “Log-in ID” field.
 - 5.6.2. Sign and date the “NAWQA Algae Sample Check” form. Put it, along with packing sheets (Bottle Shipping List) and any other related documentation (e.g., email correspondence regarding discrepancies, shipping labels), in the “Sample Tracking and Subsampling” paper folder. This folder, and the “Diatom Analysis” and “Soft-Algae Analysis” folders are prepared by the Phycology Section Project Manager at this point or prior to the log-in process (see Protocol P-13-58).
 - 5.6.3. Once samples are logged-in and checked-in, they should be held until ready to subsample, along with the folders, in the Diatom Preparation Laboratory or other sample storage area in a container clearly labeled with the NAWQA study unit and year.

Table 1. Data provided in view “vw_algae_asr” from the USGS’s BioTDB. This table also shows how the data map to the temporary NAWQA table “NAWQA_Algae_ASR” and through to the appropriate NADED tables.

vw_algae_asr field	Transformation	NAWQA_Algae_ASR	Transformation	NADED Table	NADED Field
ASR_ID		ASR_ID			
SampleID	"GSN" & intX & SampleID, where intX is the number of zeros required to make the length of the total sample ID = 8	SampleID ANSP_SampleID		Sample Identification Sample Identification	NAWQASampleID Sample ID
ANSPSampleID			autonumber, created when new records are inserted	Sample Volumes/Areas Sample Identification	SampleID SampleAutoID
SMCOD		SMCOD		Sample Identification	Client Sample ID
SUID		SUID		Site Location	Geographical Study Unit
STAID		STAID	"GS" & STAID "GS" & STAID	Site Location Site Location Sample Identification	Client Site Location ID Site Location ID Site Location ID
Reach		Reach		Sample Identification	Reach
CollectionDate		CollectionDate	Year(CollectionDate)	Sample Identification Sample Identification	Collection Date/Date1 Year
SampleType		SampleType	IIf(InStr([SampleComp],"QMH-micro"),10,IIf(InStr([SampleComp],"QMH-macro"),16,IIf(InStr([SampleComp],"QMH-moss"),17,IIf(InStr([SampleTYPE],"DTH"),11,IIf(InStr([SampleTYPE],"RTH"),12,IIf(InStr([SampleTYPE],"phytoplankton"),4)))))) If Site Location, Reach, and Collection Date are equal for more than one sample, then if [Sample Identification].[SampleTypeID] = 16, result_code = 4. Or If [Sample Identification].[SampleTypeID] = 10, then result_code = 1. Otherwise, If([SampleTypeID]=10,2, IIf([SampleTypeID]=16,3,IIf([SampleTypeID]=4,3, IIf([SampleTypeID]=17,11, IIf([SampleTypeID]=11,2, IIf([SampleTypeID]=12,2,Null))))))	Sample Identification Sample Identification	SampleTypeID result_code
SampleComponent		SampleComponent	IIf(InStr([SampleType],"RTH"),"RTH",IIf(InStr([SampleType],"DTH"),"DTH",IIf(InStr([SampleType],"phytoplankton"),"PP", IIf(InStr([SampleType],"QMH"),IIf(InStr([SampleComponent],"moss"),"QMH-moss"),"QMH-" & LCase(Left([SampleComponent],5)),""))))	Sample Identification	Sample Type
SampleAnalysisType		SampleAnalysisType			
CollectionMethod		CollectionMethod			

Table 1 (cont'd). Data provided in view “vw_algae_asr” from the USGS’s BioTDB. This table also shows how the data map to the temporary NAWQA table “NAWQA_Algae_ASR” and through to the appropriate NADED tables.

vw algae asr field	Transformation	NAWQA Algae ASR	Transformation	NADED Table	NADED Field
SplitFlag		SplitFlag			
TotalArea		TotalArea	IIf(IsNumeric([TotalArea]),CDBl([TotalArea]),Null)	Sample Volumes/Areas	AreaSampled
TotalSampleVol		TotalSampleVol	IIf(IsNumeric([TotalSampleVol]),[TotalSampleVol],[FieldVol])	Sample Volumes/Areas	SampleVolume(Client)
FieldVol		FieldVol		Sample Volumes/Areas	ClientSubSampleVolume
PreservativeVol		PreservativeVol		Sample Volumes/Areas	PreservativeVol
PreservativeType		PreservativeType			
AfterDecantVol		AfterDecantVol		Sample Volumes/Areas	AfterDecantVol
TotalVolSent		TotalVolSent			
StationName		StationName		Site Location	SiteName
LocationDesc		LocationDesc		Site Description Text	Site Description Text
WaterBody		WaterBody		Site Location	Water Body Name
StateFIPSCode		StateFIPSCode	[State/Province Abbrevs].[State/Province Code] where StateFIPSCode = [State/Province Abbrevs].StateFIPS	Site Location	State/Province Code
CountyFIPSCode		CountyFIPSCode	[County/Parish].[County/Parish Code] where CountyFIPSCode = [County/Parish].[CountyFIPSCode]	Site Location	County/Parish Code
StationLatitude		StationLatitude	Function DMStoDecimal is called	Site Location Site Location	Latitude LatDecimal
StationLongitude		StationLongitude	Function DMStoDecimal is called	Site Location Site Location	Longitude LongDecimal
StationElevation		StationElevation		Site Location	Elevation - in Feet
InsertDate		InsertDate			
InsertUserID		InsertUserID			
UpdateDate		UpdateDate			
UpdateUserID		UpdateUserID			
	assigned manually during append	ANSP_ProjectID		Sample Identification	Project ID
	assigned manually during append	ANSP_SubprojectID		Sample Identification	Subproject ID
		ANSP_DownloadDate ANSP_LastEditDate ANSP_IsForLabAnalysis ANSP_DateAppendedToNADED ANSP_ASRDownloadID		1 Site Location 97 Site Location	WaterbodyTypeCode Country Code

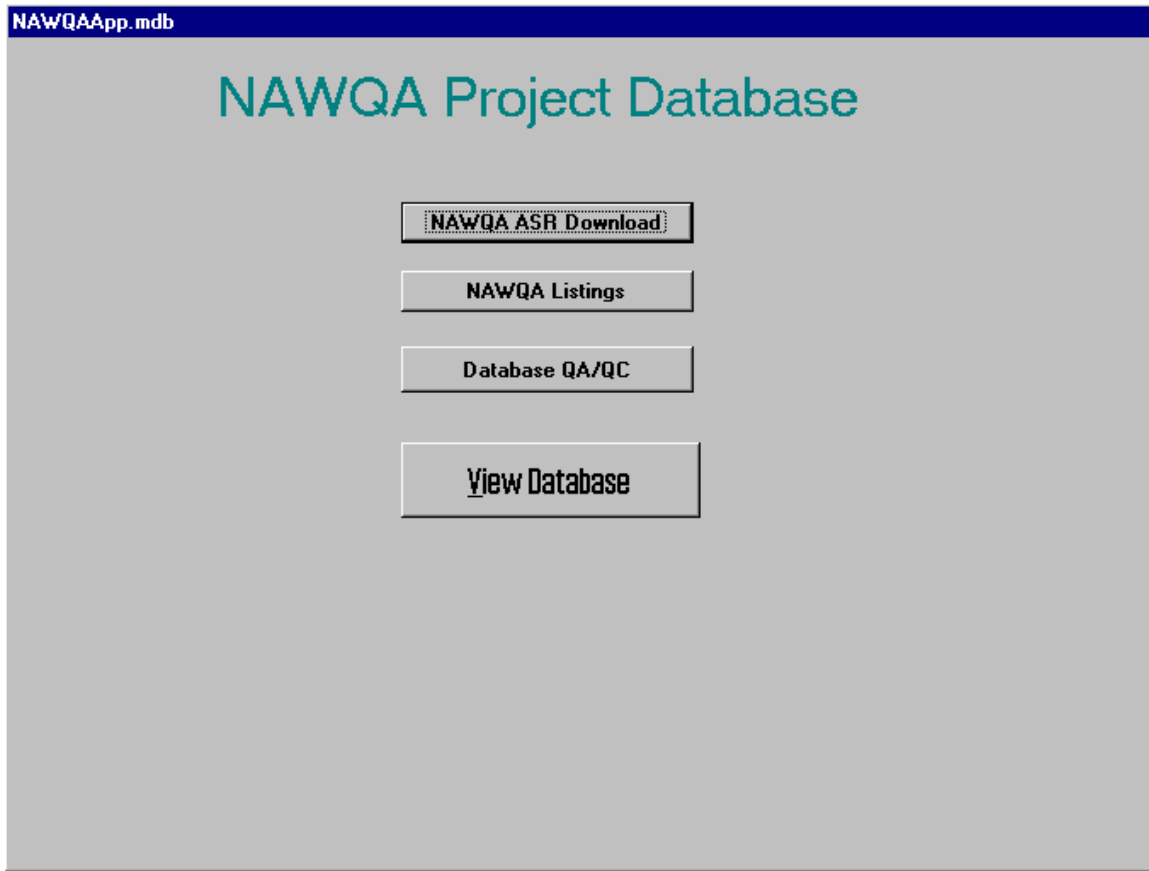

Figure 1. NAWQA Project Database screen.

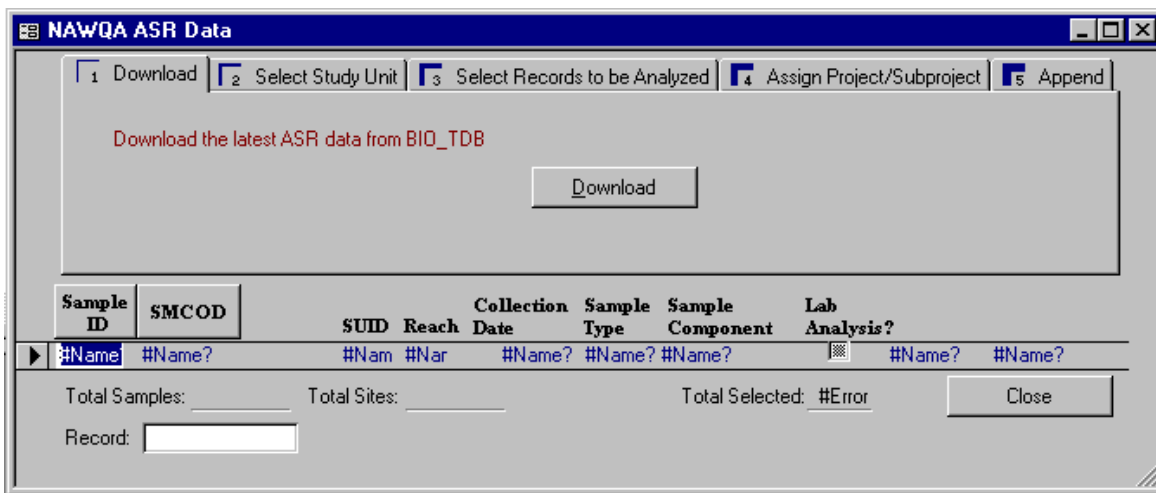

Figure 2. NAWQA ASR Data form.

NAWQA ASR Data

1 Download 2 Select Study Unit 3 Select Records to be Analyzed 4 Assign Project/Subproject 5 Append

Selection Criteria

Study Unit: ACAD Begin Year: 1996 End Year: 1996

Go

Print Form

Select the study unit and the year then select GO to see a list or Print Form to print it out

Sample ID	SMCOD	SUID	Reach	Date	Collection	Sample Type	Sample Component	Lab Analysis?		
#Name?	#Name?	#Nam	#Nar	#Name?	#Name?	#Name?	#Name?	#Name?	#Name?	#Name?

Total Samples: Total Sites: Total Selected: #Error

Record:

Close

Figure 3. NAWQA ASR Data Form—select study unit screen.

Phycology Section
Patrick Center for Environmental Research

NAWOA Algae Sample Check

The Academy of
Natural Sciences

Study Unit **NECB**

USGS Station ID: 01095220
Station Name: STILLWATER RIVER NEAR STERLING, MA
WaterBody: Stillwater River

State FIPS Code: 25 Latitude: 422439
County FIPS Code: 027 Longitude: 0714730
Elevation:

ASR ID	Sample ID	Sample Parent ID	SMCOD	Reach	Collection Date	Sample Type	Sample Component	Split Flag	Total Area	Total Sample Vol	Field Vol	Preservative Vol	Preservative Type	After Decant Vol	Total Vol Sent	Received?
7544	87110	87109	NECB0801ARE0001B	A	8/29/01	RTH	Microalgae	N	510.2	348	250	12.5	Conc. Formalin (37% Formaldehyde)		262.5	<input checked="" type="checkbox"/>
7545	87114	87113	NECB0801ADE0001B	A	8/29/01	DTH	Microalgae	N	90	250	250	12.5	Conc. Formalin (37% Formaldehyde)		262.5	<input checked="" type="checkbox"/>
7546	87116	87115	NECB0801AQE0001B	A	8/29/01	QMH	Microalgae	N	N/A	N/A	125	5	Conc. Formalin (37% Formaldehyde)		130	<input checked="" type="checkbox"/>
7547	87117	87115	NECB0801AQE0001A	A	8/29/01	QMH	Macroalgae	N	N/A	N/A	125	5	Conc. Formalin (37% Formaldehyde)		130	<input checked="" type="checkbox"/>
7548	87118	87115	NECB0801AQE0001C	A	8/29/01	QMH	Aquatic Mosses	N	N/A	N/A	125	5	Conc. Formalin (37% Formaldehyde)		130	<input checked="" type="checkbox"/>

USGS Station ID: 01102500
Station Name: Aberjona Rv at Winchester, MA
WaterBody: Aberjona River

State FIPS Code: 25 Latitude: 422650
County FIPS Code: 017 Longitude: 0710822
Elevation:

ASR ID	Sample ID	Sample Parent ID	SMCOD	Reach	Collection Date	Sample Type	Sample Component	Split Flag	Total Area	Total Sample Vol	Field Vol	Preservative Vol	Preservative Type	After Decant Vol	Total Vol Sent	Received?
7549	87126	87125	NECB0801ARE0002B	A	8/30/01	RTH	Microalgae	N	680.3	334	250	12.5	Conc. Formalin (37% Formaldehyde)		262.5	<input checked="" type="checkbox"/>
7550	87130	87129	NECB0801ADE0002B	A	8/30/01	DTH	Microalgae	N	90	250	250	12.5	Conc. Formalin (37% Formaldehyde)		262.5	<input checked="" type="checkbox"/>
7551	87132	87131	NECB0801AQE0002A	A	8/30/01	QMH	Macroalgae	N	N/A	N/A	125	5	Conc. Formalin (37% Formaldehyde)		130	<input checked="" type="checkbox"/>
7552	87133	87131	NECB0801AQE0002B	A	8/30/01	QMH	Microalgae	N	N/A	N/A	125	5	Conc. Formalin (37% Formaldehyde)		130	<input checked="" type="checkbox"/>

Total Samples: 9

Name: _____ Date: _____

Figure 4. NAWQA Algae Sample Check form.

NAWQA ASR Data

1 Download | 2 Select Study Unit | 3 Select Records to be Analyzed | 4 Assign Project/Subproject | 5 Append

Assign Selected Samples to a Project and Subproject

Project: ID: Name:

Subproject:

Sample ID	SMCOD	SUID	Reach	Collection Date	Sample Type	Sample Component	Lab Analysis?		
▶ 875	MOBL0699AQE0024B	MOBL	A	6/22/99	QMH	Microalgae	<input checked="" type="checkbox"/>	GS708131	ANSPGS9927PI
877	MOBL0699ADE0023B	MOBL	A	6/22/99	DTH	Microalgae	<input checked="" type="checkbox"/>	GS708131	ANSPGS9927PI
879	MOBL0699ARE0022B	MOBL	A	6/22/99	RTH	Microalgae	<input checked="" type="checkbox"/>	GS708131	ANSPGS9927PI
883	MOBL0799ARE0004B	MOBL	A	6/8/99	RTH	Microalgae	<input type="checkbox"/>		
887	MOBL0699ADE0005B	MOBL	A	6/8/99	DTH	Microalgae	<input type="checkbox"/>		
889	MOBL0699AQE0006B	MOBL	A	6/8/99	QMH	Microalgae	<input type="checkbox"/>		
891	MOBL0699ARE0007B	MOBL	A	6/9/99	RTH	Microalgae	<input type="checkbox"/>		
895	MOBL0699ADE0008B	MOBL	A	6/9/99	DTH	Microalgae	<input type="checkbox"/>		
897	MOBL0699AQE0009A	MOBL	A	6/9/99	QMH	Macroalgae	<input type="checkbox"/>		
898	MOBL0699AQE0009B	MOBL	A	6/9/99	QMH	Microalgae	<input type="checkbox"/>		
900	MOBL0699ARE0019B	MOBL	A	6/17/99	RTH	Microalgae	<input type="checkbox"/>		
904	MOBL0699ADE0020B	MOBL	A	6/17/99	DTH	Microalgae	<input type="checkbox"/>		
906	MOBL0699AQE0021A	MOBL	A	6/17/99	QMH	Macroalgae	<input type="checkbox"/>		
907	MOBL0699AQE0021B	MOBL	A	6/17/99	QMH	Microalgae	<input type="checkbox"/>		
909	MOBL0699ARE0025B	MOBL	A	6/23/99	RTH	Microalgae	<input checked="" type="checkbox"/>	GS708131	ANSPGS9927PI
913	MOBL0699ADE0026B	MOBL	A	6/23/99	DTH	Microalgae	<input checked="" type="checkbox"/>	GS708131	ANSPGS9927PI
915	MOBL0699AQE0027A	MOBL	A	6/23/99	QMH	Macroalgae	<input checked="" type="checkbox"/>	GS708131	ANSPGS9927PI
916	MOBL0699AQE0027B	MOBL	A	6/23/99	QMH	Microalgae	<input checked="" type="checkbox"/>	GS708131	ANSPGS9927PI
918	MOBL0699AQE0012B	MOBL	A	6/14/99	QMH	Microalgae	<input checked="" type="checkbox"/>	GS708131	ANSPGS9927PI
920	MOBL0699ARE0010B	MOBL	A	6/14/99	RTH	Microalgae	<input checked="" type="checkbox"/>	GS708131	ANSPGS9927PI
922	MOBL0699ADE0011B	MOBL	A	6/14/99	DTH	Microalgae	<input checked="" type="checkbox"/>	GS708131	ANSPGS9927PI
926	MOBL0599ADE0002B	MOBL	A	5/5/99	DTH	Microalgae	<input type="checkbox"/>		
928	MOBL0599ARE0001B	MOBL	A	5/5/99	RTH	Microalgae	<input type="checkbox"/>		

Total Samples: 30 Total Sites: 9 Total Selected: 10

Record:

Figure 5. NAWQA ASR Data Form--Assign Project/Subproject screen.

Protocol P-13-58

Tracking of Algal Sample Analysis

Frank Acker, Candia Knowles and Mark Schadler

1. PURPOSE

1.1. There are numerous stages in the analysis of samples and reporting of data in the PCER Phycology Section. For example, see Figure 1 “Sample Analysis and Data Flow,” depicting stages in analysis of U.S. Geological Survey’s (USGS) National Water-Quality Assessment Program (NAWQA) samples. It is often important to know, for a given set of samples, which stages have been completed—What is the status of samples in the overall sample analysis process? This information is necessary to estimate realistic delivery dates, have sample data complete by these dates, revise scheduling if necessary, and/or gather requested information at any given time. This protocol describes the systems in place to check the status of sample analysis from receipt of the samples at ANSP to data review.

2. SCOPE

- 2.1. This protocol is applicable to instances when it is necessary to determine the status of sample analysis.
- 2.2. This protocol is for any staff member of the Phycology Section who may need to know the status of a particular sample.

3. REFERENCE

- 3.1. PCER, ANSP. 2002. Preparation of Algal Data Files and Reports for Submission to the USGS NAWQA Program. Protocol No. P-13-53.

4. APPARATUS/EQUIPMENT

- 4.1. Personal computer connected to the ANSP network server, and access to the Phycology Section databases.

5. METHODS

- 5.1. Data documenting completion of sample analysis steps are recorded in two places. One, in Phycology Section databases at the time data are entered. Two, on paper forms in a set of three folders that are prepared at the time samples are logged-in and which are circulated with the samples: “Sample Tracking and Subsampling” folder, “Diatom Analysis” folder and “Soft-Algae Analysis” folder. The “Tracking Folders Checklist” (Table 1) lists the forms and other materials that each of the three folders might include. The Phycology Section Project Manager or project leader specifies on the checklist which forms are to be completed.

There are two methods to check the status of sample analysis. Each accesses information in one of the two places data are stored. Both are designed to obtain information on all the samples in a subproject. One method is to run a Microsoft Access query in the PHYCLGY database which returns values for key fields in various tables that store data on the sample analysis process. The other method is to check the respective “Tracking Folders Checklist” included in each of the three folders described above. The computer query method is faster and easier, but information retrieved may be incomplete because some information on forms may not yet have been entered into the database. The method of examining tracking folders may be slower, but information found will be up to date.

- 5.1.1. **Run computer query.** Run the Microsoft Access query “Data Entry Check 0: Sample Tracking” in the PHYCLGY database. This query reports values in key fields of tables that contain data on specific stages in the sample preparation and analysis process (e.g., see Figure 1). The fields included in the query will change as tracking procedures evolve. They are currently as follows:

<u>Field Name</u>	<u>Typical Value</u>	<u>Meaning</u>
“Logged In”	-1	Samples were logged-in/checked in, assigned to a subproject, and (should be) scheduled for analysis.
“Sample Volumes”	(Sample ID)	The ANS Sample Volume (a critical value for biovolume calculation) was entered.
“Sub-Sampled”	PRx or DTx	Subsamples were made.
“Diatom Slides”	h, l, a or b	Diatom slides were prepared.
“PM Fractions”	a or q	Palmer-Maloney (soft algae) fractions were prepared
“Diatom Counts”	(1)	Diatom analysis data have been entered.
“Non-Diatom Count”	(1)	Soft-algae analysis data have been entered.

Fields with null or “0” values indicate that a step has not been fully completed, or that it was completed, but data resulting from the step have not yet been entered. This query should be run weekly by the Phycology Project Manager to track sample progress and update scheduling.

- 5.1.2 **Examine tracking folders.** Locate the “Sample Tracking and Subsampling,” “Diatom Analysis,” and “Soft-Algae Analysis” folders. Look at forms required by the Tracking Folders Checklists to see what steps are completed. When all analyses are complete, all relevant forms should be initialed, and dated.

Table 1. Tracking Folders Checklist. “*” denotes forms or printouts that may not be needed if Tabulator or other applications are used.

Sample Tracking and Subsampling Folder
<ul style="list-style-type: none"> <input type="checkbox"/> Bottle Shipping List from NAWQA SU Biologist or other transmittal forms <input type="checkbox"/> “NAWQA Algae Sample Check” form <input type="checkbox"/> “Non-Conformance” form and/or E-mails documenting any discrepancies and resolutions with data or samples (not including QA/QC issues) <input type="checkbox"/> “NAWQA Sample volume/Subsample” form <input type="checkbox"/> “NAWQA DTH Subsampling Data Sheet” <input type="checkbox"/> “Data Entry Check: ANS Sample Volume” query printout <input type="checkbox"/> “Data Entry Check: Field Volumes/Areas” query printout <input type="checkbox"/> “Data Entry Check: Subsample Information” query printout
<hr/>
Diatom Analysis Folder
<ul style="list-style-type: none"> <input type="checkbox"/> “Diatom Slide Preparation” form <input type="checkbox"/> “Diatom Lab – Slide Preparation Notes” <input type="checkbox"/> “Diatom Slide Analysis” form <input type="checkbox"/> Diatom Count Sheets (“Diatom Count Reports” from Tabulator) <input type="checkbox"/> “Diatom Count Benchsheet” * <input type="checkbox"/> “Algal Biovolume Measurements” * <input type="checkbox"/> “Data Entry Check: Diatom Slide Information” query printout <input type="checkbox"/> “Data Entry Check: Diatom Count Info” * query printout <input type="checkbox"/> “Data Entry Check: Diatom Count” * query printout <input type="checkbox"/> “Data Entry Check: Diatom Count Qualitative” * query printout <input type="checkbox"/> “QA/QC Count” forms and written report
<hr/>
Soft Algae Analyses Folder
<ul style="list-style-type: none"> <input type="checkbox"/> “Periphyton analysis” form <input type="checkbox"/> “NAWQA Periphyton Sample Dilution/Concentration” forms <input type="checkbox"/> “Algal Biovolume Measurements” <input type="checkbox"/> “Data Entry Check: Palmer-Maloney Fractions” query printout <input type="checkbox"/> “Data Entry Check: Non Diatom Count Information” query printout <input type="checkbox"/> “Data Entry Check: Non Diatom Count” query printout <input type="checkbox"/> “Data Entry Check: Non Diatom Count Qualitative” query printout <input type="checkbox"/> “Periphyton Community Composition Bench Sheets” for RTH, DTH & QMH. <input type="checkbox"/> “QA/QC Count” forms and written report

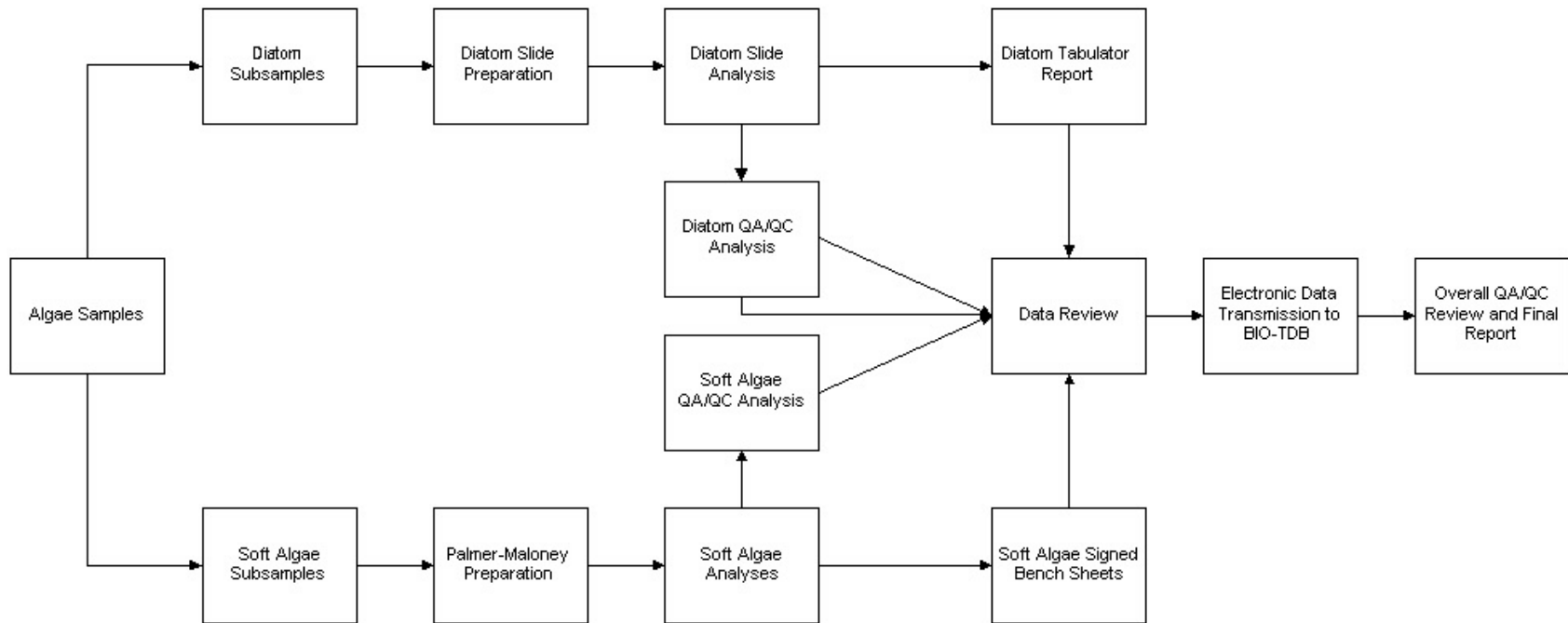

Figure 1. Sample process and analytical flow.

Protocol P-13-48

Subsampling Procedures for USGS NAWQA Program Periphyton Samples

Frank Acker, Benjamin Russell, and Erin Hagan

1. PURPOSE

1.1. The Phycology Section of the ANSP Patrick Center for Environmental Research (PCER) analyzes three types of periphyton samples collected by the U.S. Geological Survey's (USGS) National Water-Quality Assessment Program (NAWQA): Richest Targeted Habitat (RTH), Depositional Targeted Habitat (DTH) and Qualitative Multihabitat (QMH). This purpose of this protocol is to describe procedures for subsampling each of these samples in preparation for analysis of both diatoms and soft algae. Measurements of original volumes and subsample volumes of RTH and DTH samples must be precise and accurate because they will be used to calculate concentrations of algae on sampled substrates. Because of the multiple growth habits of algae (e.g., filamentous, single cell), QMH periphyton must be subsampled carefully to ensure that all algal forms are represented in the subsamples to be analyzed. The procedure outlined here, facilitated by database-generated forms, allows for efficient and accurate subsampling of USGS NAWQA periphyton samples.

2. SCOPE

- 2.1. While this subsampling procedure is applicable mainly to NAWQA periphyton samples, it can be followed for all algal samples where precise volumetric or qualitative subsampling is involved.
- 2.2. This procedure applies to personnel responsible for preparing subsamples of algal samples prior to taxonomic analyses.
- 2.3. Procedures involving quantitative samples pertain to both the RTH and DTH samples.
- 2.4. There is a special procedure involving the subsampling of samples with large amounts of sand, silt or other heavy material that can interfere with algal analysis. In this procedure, the liquid portion is subsampled by volume and the heavier material that is difficult to suspend is separated by mass.

3. REFERENCES

- 3.1. Moulton, S.R., II, J.G. Kennen, R.M. Goldstein, J.A. Hambrook. 2002. Revised protocols for sampling algal, invertebrate, and fish communities in the National Water-Quality Assessment program, U.S. Geological Survey Open-File Report 02-150. In Press.
- 3.2. Porter, S.D., T.F. Cuffney, M.E. Gurtz, M.R. Meador. 1993. Methods for collecting algal samples as part of the National Water-Quality Assessment program. U.S. Geological Survey Open-File Report 93-409, Raleigh, NC [39 pp] <http://water.usgs.gov/nawqa/protocols/OFR-93-409/alg1.html>

- 3.3. United States Geological Survey, National Water-Quality Assessment Program. 1997. Procedures for Processing NAWQA Algal Samples. Draft Manuscript. February 1997.

4. DEFINITIONS

- 4.1. **Quantitative** samples refer to those collected using the RTH and DTH sampling protocols. There is one component, microalgae, for each sample. RTH samples are designated by the letters “ARE” embedded in the middle of the NAWQA sample code; DTH sample codes have “ADE” near the middle.
- 4.2. **Qualitative** samples refer to those collected using the QMH sampling protocol. There are two components, micro- and macroalgae, for each sample. NAWQA sample codes have “QMH” near the middle, and typically have an “A” at the end for the macroalgae component and a “B” at the end for the microalgae component.

5. APPARATUS/EQUIPMENT

- 5.1. Distilled (DW) or reverse osmosis (RO) water.
- 5.2. Dispenser bottle for DW or RO water.
- 5.3. Beakers (100-ml beakers [1/sample], 250 ml).
- 5.4. Beaker holding box (24 slots).
- 5.5. Graduated cylinders (10 ml, 25 ml, 100 ml, 250 ml, 500 ml and 1 L).
- 5.6. 20-ml vials (1/sample).
- 5.7. Diamond scribe.
- 5.8. Protective clothing (gloves, lab coat or apron, eye protection).
- 5.9. Positive-draw fume hood.
- 5.10. Screen cloth (210- μ m mesh).
- 5.11. Screening apparatus.
- 5.12. Large plastic disposable weighing boats.
- 5.13. Analytical balance, capacity to 500 g, 0.1 g accuracy.
- 5.14. Spatulas.
- 5.15. Plastic disposable pipettes.
- 5.16. Desktop computer networked to Phycology Section databases.

6. SAFETY PRECAUTIONS

- 6.1. Because samples are preserved in formalin (2-10%), subsamples should be made in a positive-draw fume hood to reduce exposure. Wear gloves and eye protection.
- 6.2. The concentration of formalin in samples varies; therefore be cautious and anticipate that some samples may have much higher concentrations than others.

7. METHODS

- 7.1. Print a “NAWQA Sample Volume/Subsample Form” (Figure 1) for each set of samples. This form is generated using the report “rpt_Sample_Subsample_Volume” in the PHYCLGY database. The printed form will contain sample IDs for the set of samples selected when printing the form. Compare data on sample bottle labels with those on the form to ensure that all samples in the set are present. The type of sample (e.g., RTH, DTH, QMH) is embedded in the NAWQA sample code (Client Sample ID) (see Definitions 4.1 and 4.2); consult these to determine the type of subsampling for each. Also, to facilitate the start of the diatom subsample processing, print a “Diatom Slide Preparation Form” (Figure 2) for the set of samples. This form is generated using the report “Diatom Prep Form (NAWQA)” in the PHYCLGY database.
- 7.2. Prepare containers for both the soft algae subsample (PRx) and diatom subsample (DTx) before beginning the procedure; x = 1, 2, 3, etc. Designate the first set of subsamples as PR1 and DT1. If more than one subsample is taken, designate them PR2, PR3, etc. and DT2, DT3, etc. For each PRx sample, etch the sample and subsample IDs onto the 20-ml glass vials with a diamond scribe (e.g., GS029131 PR1), and mark them on the corresponding plastic caps with a permanent marker. Prepare clean, tall 100-ml beakers marked with numeric IDs for DTx subsamples.
- 7.3. Pour the entire contents of each quantitative sample (RTH and DTH) into a graduated cylinder of appropriate size and measure the total volume of the sample. Record the volume in the “ANSP Sample Volume” column of the “NAWQA SampleVolume/Subsample Form.” Return the sample to the original container, avoiding any loss of sample (it may be necessary to “wash” the graduated cylinder with the liquid portion of the sample). It is not necessary to measure the volume of qualitative (QMH) samples.
- 7.4. Prepare soft algae (PRx) and diatom (DTx) subsamples:
 - 7.4.1. **All subsampling procedures should be performed in a positive-draw fume hood to avoid exposure to formalin.**
 - 7.4.2. For quantitative samples (RTH and DTH) with large amounts of sand and silt that will not remain in suspension, accurate volumetric subsampling is precluded and special procedures must be followed. Skip to section 7.5 for these procedures.
 - 7.4.3. For each quantitative sample (RTH and DTH), determine an appropriate amount of subsample. In general, 20 ml is subsampled for soft algae and 20 to 100 ml is subsampled for diatoms. The more visible the algae and organic material, the less subsample is needed. If the total amount of the original sample is less than 50 ml, use about one-third for soft algae and one-half for diatoms. If there are visible growth forms (e.g., colonial spheres or filaments), macerate the soft algae sample (micro-blender, tissue grinder, etc.).
 - 7.4.4. For each quantitative periphyton sample, suspend the algal material by shaking or swirling, and carefully pour the amount of PRx subsample determined in section 7.4.3 into a graduated cylinder. Transfer the subsample to its corresponding etched 20-ml bottle. Repeat the measurement procedure for the DTx subsample, and transfer the material to a prepared 100-ml beaker. Record the volume of each subsample on the “NAWQA Sample Volume/Subsample Form” (Figure 1). In addition, record the

beaker ID for the diatom subsample on the “Diatom Slide Preparation Form” (Figure 2). Proceed to section 7.6.

- 7.4.5. For each component of the qualitative samples, create a subsample for soft algae using procedures in sections 7.4.3 and 7.4.4, **without the maceration step**. If there are visible macro forms, selectively add a portion of these to the subsample(s). Prepare a diatom subsample for only one component; use the microalgae component if both components are available. Subsample the diatom subsample as in sections 7.4.3 and 7.4.4. Skip to section 7.6.
- 7.5. Subsample quantitative samples with heavy sediment.
 - 7.5.1. Some samples contain substantial amounts of heavy particles that cannot be kept in suspension long enough for accurate quantitative volumetric subsampling. In such cases, the sand-size ($>210\ \mu\text{m}$) and larger particles of sediment must be separated from the liquid fraction of the sample, and sediment and liquid fractions are subsampled individually. After both liquid fraction and sand fraction subsamples are taken, they are combined into a final subsample. Record all calculations on the “NAWQA DTH Subsampling Data Sheet” (Figure 3).
 - 7.5.2. **Preparation of screening apparatus:** Place a clean weighing boat on the analytical balance. Set up the screening device with a clean piece of screen and set it on the weighing boat. Record the mass of the apparatus plus boat on the data sheet (Figure 3), and re-zero the balance. Remove screening apparatus and place on top of a large glass beaker.
 - 7.5.3. **Suspend sand and sediment by vigorously agitating the sample:** Immediately pour this material through the screening device into the beaker. If the screening device becomes clogged, use a plastic spatula to keep the sediments suspended until all the liquid passes through the screen. Use liquid from the beaker to rinse sediment remaining in the sample bottle through the screen. The material left on the screen is the “sand fraction;” the liquid retained in the beaker is the “liquid fraction.”
 - 7.5.4. **Determination of fraction amounts:** Place the screening apparatus with sand fraction onto the weighing boat on the balance. Record the mass of the sand fraction and remove the boat and screening bottle from the balance. Measure the volume of the liquid fraction in an appropriate graduated cylinder and record. Return the liquid fraction to the sample bottle.
 - 7.5.5. **Determination of subsample proportions:** Shake the sample bottle containing the liquid fraction and use a plastic disposable pipette to measure out a liquid sample (see section 7.4.3) into a 10-ml graduated cylinder (typically, about 5 ml). Record the liquid fraction subsample volume. Place the graduated cylinder on the balance and re-zero. Calculate the proportion of the whole liquid fraction represented by the subsample volume (subsample volume divided by liquid fraction volume) and record. Calculate the mass of the sand fraction subsample to be taken (the above proportion multiplied by the total sand fraction mass) and record.
 - 7.5.6. **Completing the subsample:** Using the plastic spatula, add the appropriate mass of sand fraction to the tared graduated cylinder on the balance. Once the calculated portion of sand is added, wash any sand from the edges by inverting the cylinder while capping it with your thumb. Measure and record the total subsample volume. Transfer the completed subsample to the appropriate container (a tall 100-ml beaker

for diatom subsamples or an etched 20-ml vial for soft algae subsamples). Sand remaining can be rinsed into the subsample container with DW or RO. For soft algae subsamples, fill the vial with DO or RO water to 20 ml; calculate and record the dilution/concentration factor (DCF). For diatom subsamples, calculate and record the DCF, fill beaker with DW or RO water, set aside for digestion and record the beaker number on the “Diatom Slide Preparation Form” (Figure 2).

- 7.5.7. **Cleanup:** When finished with subsampling, carefully return the sand fraction to the sample bottle. Record the total volume of sample removed. Remove the screen from the screening apparatus and place in soapy water to soak. Clean all glassware and the screening apparatus with hot, soapy water and rinse with DW or RO water.
- 7.6. Complete filling-out the “NAWQA Sample Volume/Subsample Form” (Figure 1) and add it to the subproject “Sample Tracking and Subsampling” folder (See ANSP Protocol P-13-58). Enter subsample data in PHYCLGY database tables, as described below.
 - 7.6.1. Enter data for the following fields into the “Sample Volumes/Areas” table. This table will already contain a record for each sample with the sample identification fields filled out. This information was added to the table during the log-in process (see Protocol P-13-47).
 - 7.6.1.1. ANS vol (ml) – the amount of sample (in ml) received at ANSP (column labeled “ANSP Sample Volume” on paper form).
 - 7.6.1.2. Date ANS Samp Vol Measured.
 - 7.6.1.3. ANS Samp Vol Measured By – Worker ID number (from “Worker Name” table) of the person who measured the sample volume.
 - 7.6.2. Table “Subsample Information.” Enter data for diatom and soft-algae subsamples, each as a separate records.
 - 7.6.2.1. SampleID – the ANSP sample code (e.g., GS029131).
 - 7.6.2.2. SubSampleID – distinguishes between diatom (DTx) and soft algae (PRx) subsamples.
 - 7.6.2.3. Dilution/Concentration Factor – the number needed to multiply the subsample volume by to get 20 ml (record as 1 if no dilution or concentration or if qualitative subsample).
 - 7.6.2.4. WorkerID – Worker ID number of the person who did the subsampling; located in the Worker Name table of the NADED database.
 - 7.6.2.5. Date Subsampled.

8. QUALITY ASSURANCE/QUALITY CONTROL

- 8.1. These procedures were developed by the ANSP as suggested in the USGS NAWQA Program protocols and contract documents. The specific procedures (including type of glassware, amounts of subsamples, etc.) evolved over a 5-year period. The procedures for samples with large amounts of sand or heavy sediment were developed by the USGS, adapted by the ANSP with little modification, and have been used since 1997.

- 8.2. Because algae are microscopic, the possibility of contamination of samples is great. Laboratory rooms where raw samples are subsampled should be kept as clean as possible. Lab bench surfaces should be kept clean and free of debris.
- 8.3. Quantitative samples need to be mixed well during subsampling (possibly blended), to avoid clumps caused by natural growth forms (colonies, filaments, etc.).
- 8.4. The appropriate size of graduated cylinder for measuring samples and subsamples is critical. The sample should be at least one-third the capacity of graduated cylinder and the units of the graduated cylinder should allow estimation to the nearest milliliter (finer for the small graduated cylinders used to measure a portion of a subsample).

NAWQA Sample Volume/Subsampling Form: ANSPGS9901SB

Subproject ID: ANSPGS9912PR

			ANSP	Date		Volume	Volume		Sub-
		Subsample	Sample	Measured	Measured	Subsampled	Subsampled	Date	sampled
Sample ID	Client Sample ID	ID	Volume (ml)	(ANSP)	By	Periphyton (ml)	Diatoms (ml)	Sampled	By
GS021783	OZRK0997ARE0001B								
GS021785	OZRK0997AQE0001A								
GS021787	OZRK0997AQE0001B								
GS021793	OZRK0997ARE0002B								
GS021795	OZRK0997AQE0001A								
GS021797	OZRK0997AQE0002B								

Data Entered By: _____ __/__/__

Confirmed By: _____ __/__/__

Figure 1. NAWQA Sample Volume/Subsampling Form.

Diatom Slide Preparation Form - NAWQA

For use with Protocol P-13-42 and samples collected for the U.S.G.S National Water Quality Assessment Program
Phycology Section - Patrick Center for Environmental Research - The Academy of Natural Sciences

Project Name: USGS NAWQA Algae CO-OP Year 3 **Project ID:** GS708230 **ANSP Account Number:** 708-2302

Subproject ID: ANSPGS0109PR **Subproject Name:** New England Coastal Basins (NECB 2001) USGS NAWQA

Digestion Method: Microwave-Nitric Acid (P-13-42) **Digested By:** _____ **Date:** ___/___/___

Decant Dates: 1 _____ 2 _____ 3 _____ 4 _____ 5 _____ 6 _____ 7 _____

Slide Prep. Method: Strewn Mount **Settled By :** _____
Mounting Medium: Naphrax **Mounted By:** _____

Sample ID	Client Sample ID	Beaker #	Microwave Vessel #	ul dripped	Estimates
GSN87110	NECB0801ARE0001B	_____	_____	_____	_____
GSN87114	NECB0801ADE0001B	_____	_____	_____	_____
GSN87116	NECB0801AQE0001B	_____	_____	_____	_____
GSN87117	NECB0801AQE0001A	_____	_____	_____	_____
GSN87118	NECB0801AQE0001C	_____	_____	_____	_____
GSN87126	NECB0801ARE0002B	_____	_____	_____	_____
GSN87130	NECB0801ADE0002B	_____	_____	_____	_____
GSN87132	NECB0801AQE0002A	_____	_____	_____	_____
GSN87133	NECB0801AQE0002B	_____	_____	_____	_____

Remnants of Original Samples Transmitted By: _____ **Date:** ___/___/___ **To (location):** _____

Figure 2. Diatom Slide Preparation Form - NAWQA.

ANSP-__-__-__-DS

NAWQA DTH Subsampling Data Sheet

SampleID:_____ SubsampleIDs:_____ Date: __/__/__
NAWQA ID:_____ Init:_____

1. Mass of weighing boat + screening apparatus: _____g
2. Sand fraction mass: _____g
3. Liquid fraction volume: _____ml
4. Liquid fraction subsample volume: _____ml
5. Proportion of liquid fraction represented by subsample: _____
(#4 divided by #3)
6. Mass of sand fraction to be taken: _____g
(#5 multiplied by #2)
7. Total subsample volume: _____ml
Subsample ID: DT1
Beaker #: _____
8. Diatom subsample DCF:
New subsample volume (20 ml) / Total subs. volume (#7)= _____

-
9. New sand fraction mass: _____g
 10. New liquid fraction volume: _____ml
 11. Liquid fraction subsample volume: _____ml
 12. Proportion of liquid fraction represented by subsample: _____
(#11 divided by #10)
 13. Mass of sand fraction to be taken: _____g
(#12 multiplied by #9)
 14. Total subsample volume: _____ml Subsample ID: PR1
 15. Periphyton subsample DCF:
New subsample volume (20ml) / Total subs. volume (#13)= _____

Total volume removed from sample: _____ml

Figure 3. NAWQA DTH Subsampling Data Sheet.

Protocol P-13-42

Diatom Cleaning by Nitric Acid Digestion with a Microwave Apparatus

Frank Acker, Benjamin Russell and Erin Hagan

1. PURPOSE

- 1.1. To identify and enumerate diatoms accurately at the species and variety levels, it is necessary to remove both extracellular and intracellular organic matter from the siliceous frustules of diatoms and other material in the sample. Removing the organic matter is necessary so that all details of diatom structures necessary for taxonomic identification are clearly visible. This protocol describes a method for removing organic material from a sample by digesting it with nitric acid in a microwave apparatus.
- 1.2. Traditional nitric acid digestion methods utilize a hotplate to heat samples and acid in open beakers. The procedure described herein takes advantage of a microwave apparatus to heat the acid/sample mixture in closed containers. This procedure produces a cleaner sample (more complete digestion) with less contamination, and is safer and more convenient (much less use of acid) (Acker et al. 1993).

2. SCOPE

- 2.1. This procedure is applicable for cleaning diatoms from a wide variety of samples including, but not limited to, periphyton samples from diatom slides or other artificial substrates, collections from natural substrates, surface sediment or sediment core samples, and net or whole water collections of phytoplankton. Material to be cleaned may be in a moist, dry or preserved state. If material to be processed contains preservatives or other chemical substances, refer to the cautionary notes in sections 5 and 7.14.
- 2.2. This procedure applies to personnel responsible for preparing diatom slides for taxonomic or community analysis purposes.
- 2.3. This procedure applies to the use of Advanced Composite Vessels (CEM Corporation).
- 2.4. The procedure for diatom sample digestion using nitric acid and a microwave apparatus has been employed by the ANSP since 1992. In 1998, Lined Digestion Vessels were replaced by Advanced Composite Vessels because of their durability. The procedures described above evolved from nitric acid/hotplate digestions performed at the ANSP for over 40 years. The acid/hotplate procedures are described in ANSP Protocol No. P-13-02 and may be used occasionally for single samples.
- 2.5. If samples are essentially free from organic detritus, and critical taxonomic work is not required (e.g., multiple phytoplankton samples where the taxonomy is well known), this nitric acid digestion method may not be necessary. A hydrogen peroxide method (not described here) or burn mount procedure may be considered in these cases. However, for the majority of applications, the nitric acid digestion method is recommended.

3. REFERENCES

- 3.1. Acker, F.W., D.M. Walter, N.A. Roberts and D.F. Charles. 1993. Microwave Digestion of Diatom Samples. Poster presentation given at the 12th North American Diatom Symposium, 23-25 September 1993, Delta Marsh, Manitoba, Canada.
- 3.2. American Public Health Association, American Water Works Association, Water Environment Federation (APHA, AWWA, WEF). 1992. Standard Methods for the Examination of Water and Wastewater. 18th ed.
- 3.3. J.T. Baker Chemical Company. Saf-T-Training Manual and Tests.
- 3.4. CEM Corporation. Instructions for Use of Lined Digestion Vessels (P/N 323000 Rev. 0).
- 3.5. CEM Corporation. Instructions for Use of Advanced Composite Vessels (P/N600214 Rev. 1).
- 3.6. Patrick, R. and C. Reimer. 1967. Diatoms of the United States. Vol 1. Monograph No. 13, Academy of Natural Sciences of Philadelphia. 688 pp.
- 3.7. PCER, ANSP. 2002. Analysis of Diatoms in USGS NAWQA Program Quantitative Targeted-Habitat (RTH and DTH) Samples. Protocol No. P-13-39.
- 3.8. PCER, ANSP. 2002. Log-In Procedures for USGS NAWQA Program Algal Samples. Protocol No. P-13-47.
- 3.9. PCER, ANSP. 2002. Subsampling Procedures for USGS NAWQA Program Periphyton Samples. Protocol No. P-13-48.
- 3.10. PCER, ANSP. 1988. Diatom Cleaning by Nitric Acid Digestion. Protocol No. P-13-02.
- 3.11. PCER, ANSP. 1994. Subsampling and Determination of Wet and Dry Weights of Lake Sediment Samples. Protocol No. P-13-43.
- 3.12. PCER, ANSP. 1990. Laboratory Safety Manual.

4. DEFINITIONS

- 4.1. **Digestion** in this procedure refers to the solubilization of organic material by strong acid oxidation.
- 4.2. Diatom cells, called **frustules**, are composed of two **valves**. They have a siliceous structure, the features of which are used for taxonomic identification.

5. APPARATUS/EQUIPMENT

- 5.1. Positive-draw fume hood.
- 5.2. Safety glasses.
- 5.3. Acid-impervious hand protection.
- 5.4. Laboratory coat or apron, acid resistant.
- 5.5. Microwave apparatus (CEM Model MDS-2100):
 - 5.5.1. 0-950 watts (1% intervals).

- 5.5.2. Controlled and monitored temperature (fiber optics) and pressure.
- 5.5.3. Programmability for different cycles of temperature, pressure, and time at various temperature and pressure combinations.
- 5.5.4. Rotating turntable.
- 5.6. Closed microwave digestion vessel [see Figure 1 “Standard Advanced Composite Vessel (Cross Section)”]:
 - 5.6.1. Vessel liner (Teflon PFA[®]).
 - 5.6.2. Vessel liner cover (Teflon PFA[®]).
 - 5.6.3. Vessel cap (reinforced polyetherimide, microwave “invisible”).
 - 5.6.4. Thread ring (reinforced polyetherimide, microwave “invisible”).
 - 5.6.5. Sleeve (advanced composite material, microwave “invisible”).
 - 5.6.6. Rupture membrane (Teflon PFA[®]).
 - 5.6.7. Vent tube (Teflon[®]).
 - 5.6.8. Vent fitting (Teflon PFA[®]).
 - 5.6.9. Ferrule nut (Teflon PFA[®]).
- 5.7. Digestion vessel for temperature and pressure control and monitoring; see Figure 2 “Advanced Composite Vessel for Pressure and Temperature Control.” Vessel liner, vessel cap, thread ring, sleeve, rupture membrane, vent fitting and ferrule nuts as in sections 5.6.1, 5.6.3, 5.6.4, 5.6.5, 5.6.6, 5.6.7 and 5.6.8, respectively.
 - 5.7.1. Vessel liner cover (Teflon PFA[®]) with exhaust, temperature and pressure ports.
 - 5.7.2. Thermowell (Pyrex with Teflon coating).
- 5.8. Reagent grade nitric acid (~70%).
- 5.9. Potassium dichromate (crystal form).
- 5.10. 100-ml tall glass beakers.
- 5.11. Reverse osmosis water (RO) or distilled water (DW).
- 5.12. Faucet siphon apparatus.
- 5.13. 20-ml glass vials; caps with coned liners.
- 5.14. Vial labels.
- 5.15. Diamond scribe.
- 5.16. Wash bottle for RO or DW.
- 5.17. Single-edged razor blades.
- 5.18. pH indicator paper.

6. SAFETY PRECAUTIONS

- 6.1. Nitric acid is an extremely hazardous reagent. As a strong acid oxidizer it can cause severe burning of exposed skin and clothing. At room temperature, concentrated nitric acid produces intense fumes when exposed to open air.
- 6.2. Any concentrated nitric acid containers open to the air must be contained within a positive-draw fume hood at all times. There are no exceptions to this rule.
- 6.3. Personnel are required to wear safety glasses, protective gloves and lab coats at all times when handling concentrated nitric acid. This is especially important when handling/venting the digestion vessels.
- 6.4. When samples are delivered to the Diatom Preparation Laboratory, personnel who will work with the samples must be informed if any preservatives have been used in the samples (e.g., formaldehyde, Lugol's solution, glutaraldehyde, etc.). This information should be on the shipping forms included with the samples or affixed to the shipping container. Consult the Material Safety Data Sheets (MSDS) located on the 2nd floor of ANSP near the Diatom Preparation Laboratory for information on any of the above preservatives and how to handle them properly. Unexpected, violent and/or noxious reactions can occur during the cleaning procedure if nitric acid is mixed with other chemical substances. **Samples are to be rejected by laboratory personnel if their collection history and content are not fully known.**
- 6.5. **Never** use an Advanced Composite Vessel without a composite sleeve.
- 6.6. **Never** install more than one rupture membrane in the vessel cover.
- 6.7. Prior to use, all vessel components must be dry and free of particulate matter. Drops of liquid or particles will absorb microwave energy, causing localized heating which may char and damage vessel components, possibly leading to vessel failure.

7. METHODS

Algal material that requires processing for diatom analysis comes to the preparation lab in several forms, depending on the collection protocol. Diatom collections may come from glass periphytometer slides, tile or other artificial substrates, phytoplankton suspensions, culture material, dried herbarium material and lake sediments. To produce a diatom slide, regardless of the kind of collection, the lab technician must remove all organic materials from the sample so that diatom frustules can be identified. This may require a preliminary examination of the raw sample with a microscope to determine the proper amount to digest. Proper cell densities for diatom slide analysis are described in Protocol No. P-13-39. Procedures for other sample types are discussed below, including samples with preservatives (sections 5 and 7.14), and samples with carbonates (section 7.14). This procedure should be started only after all samples are logged in (refer to Protocol No. P-13-47).

Record sample digestion data (Beaker #, Microwave Vessel #, notes) on the appropriate "Diatom Slide Preparation Form" (see, for example, Figure 2 in ANSP Protocol No. P-13-48). For most types of samples this form will have been generated during the process of preparing subsamples, and placed in the "Diatom Analysis" folder. Sample digestion data are not added to a computer database. If a "Diatom Slide Preparation Form" has not been generated, it can be printed using a report in the PHYCLGY database. There are different reports for different types of samples and

projects (e.g., diatometer, survey, NAWQA, sediment), all of which contain “Diatom Prep Form” as the first part of their name. Confirm that all samples to be processed are recorded on the form before proceeding.

- 7.1. **Glass slides with attached periphyton (e.g., diatometer slides).** Based on the thickness of attached growth, choose one or more slides from the same sampling station or site for the cleaning process (set aside those not used in the cleaning process for eventual curation as “uncleaned material”). Place the chosen slides from individual sites in a single, numbered 100-ml beaker. Record the number of slides to be processed and the respective beaker number on the “Diatom Slide Preparation Form”. Fill each beaker with distilled water so as to completely immerse the slides, and allow the slides to soak for a minimum of 12 hours. After the soaking period, use a disposable single-edged razor blade to scrape algae from the slides (including the slide edges) into the beaker. Then dip the slides and razor blade in the water-filled beaker to transfer remaining scraped material from the slides. Using a wash bottle filled with distilled water, carefully rinse any material still adhering to the slides or the razor blade back into the beaker. At this point, cross check the etched label of the slide with the information on the “Diatom Slide Preparation Form” to ensure that the slides have been transferred from the proper field sites and that the date of installation is correct. If at this stage there are any discrepancies, they should be noted on the “Diatom Slide Preparation Form” and resolved. Record the number of sides scraped for each sample.

Allow the material in the beakers to settle for a period of at least 8 hours without being disturbed. Then siphon off the supernatant liquid without disturbing any of the material that has settled to the bottom. In the siphoning process, the tip of the siphon should be placed just beneath the water’s meniscus, and moved slowly down as the water level drops, to prevent loss of material through water column turbulence and contamination of the siphon tip. As much water as possible should be removed without disturbing the sedimented material. Proceed to section 7.5.

- 7.2. **Water suspended samples (e.g., phytoplankton samples, culture material).** If necessary, concentrate samples by siphoning water off undisturbed samples as described in section 7.1 until the sample contains approximately 20 ml of water and associated material. If a quantitative analysis is required, the original volume of the sample must be recorded. If the sample is too large or too dense to clean in its entirety, a subsample should be taken and processed. Volumes of the subsample and the original sample must be recorded on a “Sample Volume/Subsample” form (e.g., See Protocol P-13-48). Then transfer the sample to 100-ml beakers as in section 7.1. Proceed to section 7.5.
- 7.3. **Sediments (e.g., bottom substrate samples or sediment core samples).** Transfer approximately 0.5 to 1.0 cc of either moist or dry sediment to a 100-ml beaker. If dry, a small amount of water may be added to the sample (approximately 10 ml) to hasten disaggregation. If the sample is to be analyzed quantitatively, record the wet weight, volume, or dry weight of the sample to be processed, according to the specifications of the study protocol. Unless otherwise specified, use procedures and forms in Protocol No. P-13-43. Proceed to section 7.5.
- 7.4. **Other.** Samples from other sources (e.g., natural rock substrates; soft sediments from rivers) may also be digested using this procedure. As in the above cases, it is important to begin with a concentrated sample to which nitric acid can be added safely in order to process a large enough sample to yield a sufficient concentration of cleaned diatoms for the required analyses. Care should always be taken to ensure that violent reactions will not

take place upon the addition of acid. For quantitative analyses, the weight, area or volume of the original sample should be noted as required by the protocol.

7.5. Addition of nitric acid. WARNING. THE FOLLOWING PROCEDURE IS TO BE PERFORMED ONLY IN A POSITIVE-DRAW FUME HOOD. TECHNICIANS ARE REQUIRED TO WEAR SAFETY GLASSES AND PROTECTIVE GLOVES!

Assemble part of the digestion vessel before adding acid (sections 7.6.1 and 7.6.2). Place sample into the vessel liner portion of a microwave digestion vessel. Add concentrated nitric acid to the sample in the vessel liner; add an amount of acid equal to the amount of sample. If the sample contains a very high amount of organic material, more acid can be added (routinely the sample is in a 10-ml water matrix requiring the addition of 10-ml nitric acid). Initially, add acid very slowly and with great caution, anticipating that an unexpected reaction may take place. After determining that there is no possibility of a violent reaction, slowly and cautiously add the remainder of the acid to the samples.

7.6. Preparation, assembly of digestion vessels and connecting to the microwave apparatus.

- 7.6.1. Before the assembly of the digestion vessels, new rupture membranes must be seated in the vessel liner covers as illustrated in Figure 3, "Installation and removal of rupture membrane." Make sure that there is only one rupture membrane seated in each vessel liner cover.
- 7.6.2. Once the rupture membrane is seated, turn the vent stem back into the vessel liner cover until hand tight. Do not apply excess pressure or use a wrench to tighten the vent stem! Sections 7.6.1 and 7.6.2 should be completed prior to the acid addition (section 7.5).
- 7.6.3. Place the vessel liner cover (with rupture membrane and vent stem installed) on top of the vessel liner.
- 7.6.4. Thread the vessel cap onto the thread ring (by turning in a clockwise direction) until hand tight. As with the vent stem assembly, do not apply excess pressure or use a wrench to tighten the vessel cap!
- 7.6.5. Insert the vent tube into the vessel by threading through the ferrule nut into the vent fitting (located on top of the vessel cover extending above the vessel cap).
- 7.6.6. Place the complete vessel assembly into a turntable, orienting the vent tube towards and into the collection vessel at the center of the turntable. Record position of vessel (in turntable) on the Diatom Slide Preparation Form.
- 7.6.7. Complete the vessel assembly by placing an advanced composite sleeve over the liner and under the thread ring.
- 7.6.8. For the remaining vessels repeat steps 7.6.1 to 7.6.7. Note the differences for the vessel with the temperature and pressure controls (assembly is similar but with a different type of vessel liner cap and cover); see Figure 4, "Installation of rupture membrane in vent fitting of Advanced Composite Vessel with Temperature/Pressure control cover."
- 7.6.9. Place turntable with vessels into the microwave apparatus cavity on its drive lug. Turn on microwave apparatus and rotate the turntable. After confirming the operation

of the turntable, rotate so that the vessel with the temperature and pressure sensors is at 12:00 (as looking into the microwave cavity).

7.6.10. Bleed and connect pressure sensing line:

7.6.10.1. Using keypad controls and menu system, rotate turntable to 9:00.

7.6.10.2. Turn pressure valve (outside left of microwave cavity) to **open**.

7.6.10.3. Tap pressure sensing line to get air bubbles to connection end.

7.6.10.4. With the syringe filler (outside left of microwave cavity), flush air bubbles out of the pressure sensing line.

7.6.10.5. Connect pressure sensing line to the pressure port on the temperature and pressure vessel liner cover (use only hand pressure!) and place pressure sensing line in center post of the turntable; see Figure 5, "Routing of pressure sensing line and fiber optic temperature probe."

7.6.10.6. Turn pressure valve to neutral.

7.6.11. **Connect fiber optic temperature probe:** Without bending, place fiber optic probe carefully (note: it is glass!) into the thermowell of the temperature and pressure vessel liner cover and connect (use only hand pressure for the connection!). Thread probe into center of the turntable, similar to the pressure sensing tube; see Figure 5, "Routing of pressure sensing line and fiber optic temperature probe."

7.7. **Configuring the microwave apparatus.**

7.7.1. From the main menu, choose either to load a preexisting program (current program "Diatom New Vessel") or to enter new operating conditions (and new programs) from the keypad.

7.7.2. In the view mode, use the arrow keys and numeric keypad to set the following operating conditions:

Cycle 1 - 25% power, 20 PSI, 5 min @ pressure;

Cycle 2 - 80% power, 60 PSI, 5 min @ pressure;

Cycle 3 - 90% power, 100 PSI, 20 min @ pressure;

Adjust power settings for number of vessels by reducing 3% for each vessel less than a full tray (12 vessels);

Record additional information in the "Sample Information" screen.

7.7.3. Make sure printer is connected and on and print out operating conditions and sample information.

7.8. Start the microwave apparatus; the program will take about 60 min.

7.9. It is crucial that the operator monitor the temperature and pressure controls (readings printed every 30 sec) during the course of the digestion. In stages the temperature will rise from room temperature to about 170°C (up to 90°C in Cycle 1; up to 140°C in Cycle 2; up to 170°C in Cycle 3) and pressure will go from 0 psi to 100 psi (0-25 psi in Cycle 1, 25 to 70 psi in Cycle 2; 70-100 psi in Cycle 3). In the first two cycles, the rise will be even for 5-10 min and then hold near the maximum for 5 min; in Cycle 3 the rise will be fast (within a minute or two) and then hold for 20 min (@ 90-100 psi and 160-170°C). Deviations from

this controlled rise in temperature and pressure could indicate a break in a vessel or problem sample reaction. The digestion should be stopped immediately if either the temperature or pressure does not rise evenly through the cycles.

- 7.10. Remove samples from the microwave apparatus (after temperature and pressure conditions are back to normal levels; ~30-45 min):
 - 7.10.1. Place the vessel with the temperature and pressure controls at 9:00.
 - 7.10.2. Vent the vessel with the temperature and pressure controls by turning the vent fitting counter-clockwise. Note: gloves, lab coat and eye protection should be worn during venting of vessels.
 - 7.10.3. Carefully take out the fiber optic probe and place in one of the holes near the top of the microwave cavity.
 - 7.10.4. Remove pressure sensing line and place away from the turntable.
 - 7.10.5. Remove turntable from microwave cavity and place in fume hood; carefully vent each of the vessels by slowly turning the vent fitting counter-clockwise.
- 7.11. Remove vessel caps, vessel liner covers and transfer samples to tall, 100-ml beakers, washing liner with DW or RO from wash bottle. Fill beaker with DW; be sure to check beaker numbers on "Diatom Slide Preparation Form."
- 7.12. **Decanting procedure.** After 8 hours, siphon off the supernatant in a manner similar to that described in section 7.1. DW is again added to beakers. Repeat this settling and siphoning procedure at least five more times or until the pH is similar to that of the DW or RO (above 6.5). Note date of each decant on the "Diatom Slide Preparation Form."
- 7.13. **Transfer procedure.** Carefully swirl the cleaned material remaining in the bottom of each beaker after the final siphoning and then pour it into a 20-ml glass vial which has been previously labeled with Sample ID and SubSample ID. (Labels should be made on the side of the vial using a diamond scribe and on the cap using an indelible marker). Using a wash bottle containing DW or RO water, wash any remaining material adhering to the beaker sides into the vial, and bring the volume of each vial to exactly 20 ml. Cap the vial and store with others until ready to make slides. Initial and date the "Diatom Slide Preparation Form," put it in the "Diatom Analysis" folder, and keep the folder with the samples.
- 7.14. **Precautions.** Samples containing preservatives or other chemicals should be clearly identified at the time of submission to the diatom laboratory. If chemical additives are suspected, but not indicated on the preparation form, technicians should request confirmation from the Principal Investigator or the Project Leader as to the contents of the samples. If the samples are known to contain formaldehyde, Lugol's solution, glutaraldehyde or any other noxious material, a dilution step should be performed by the addition and siphoning of DW or RO similar to that described in section 7.12 (excluding the consideration of pH) until it is safe to assume that the added chemical or chemicals have been significantly diluted. Samples containing significant amounts of carbonate will tend to bubble and sputter on the initial addition of acid. In this case, acid addition should be suspended immediately until all evidence of a reaction has ceased.

8. QUALITY ASSURANCE/QUALITY CONTROL

- 8.1. Observed loss of material at any stage of this procedure compromises quantitative samples. Samples which experience such loss should be discarded immediately if sufficient material has been retained to allow for a fresh sample. If the compromised sample is the only material available from the original sample, the procedure should be completed, and the nature of spillage or loss should be documented clearly on the “Diatom Slide Preparation Form.”
- 8.2. Diatom frustules are microscopic, generally falling in the fine silt size range; therefore, there is a possibility that samples can be contaminated. Laboratory rooms where raw or processed samples are handled should be kept as clean as possible. Lab bench surfaces should be kept clean and free of debris. Techniques similar to those used for sterile experiments (bacteriological plating, etc.) should be followed to minimize the risk of cross contamination of samples. Where feasible, disposable pipettes, stirrers, etc. should be used. Where they cannot, they should be rinsed in DW or RO water after each sample, and stored dry.
- 8.3. Samples with live algae should be refrigerated and kept in the dark (live diatoms are capable of continued growth as long as they are receiving light).
- 8.4. New glassware and digestion vessel liners should be washed and/or rinsed prior to use. Used glassware should be vigorously scrubbed, washed with a detergent, and rinsed at least three times with DW or RO to prevent contamination. Previously used digestion vessel liners should be washed with a detergent and soft brush (beware of abrasives, however) and rinsed at least three times with DW or RO. (Explanatory note: at times tap water, because of algal blooms and use of diatomaceous earth filters, may contain diatoms.) All equipment should be stored dry to prevent growth of algae or fungi.

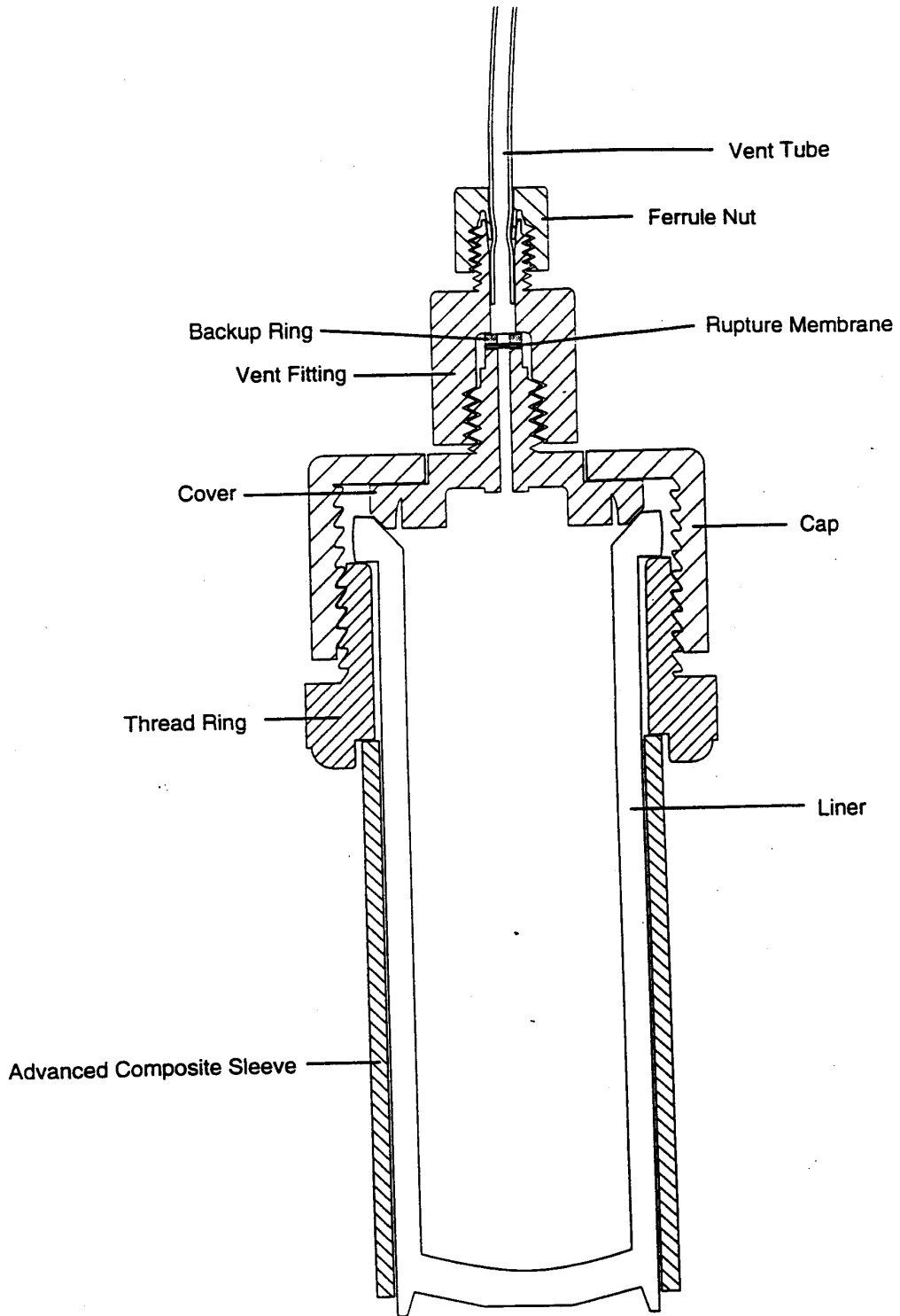

Figure 1. Standard advanced composite vessel (cross section).

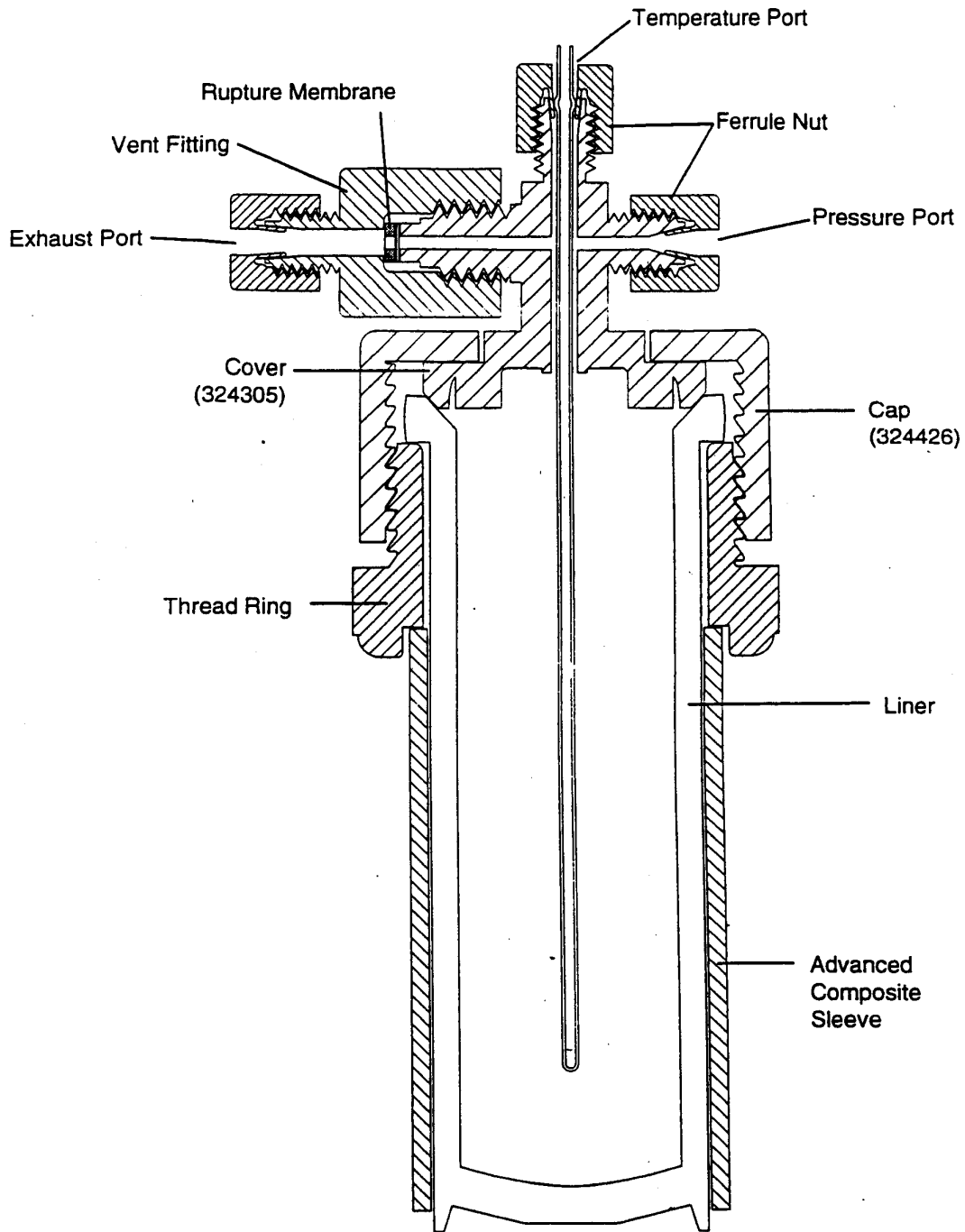

Figure 2. Advanced composite vessel for pressure and temperature control.

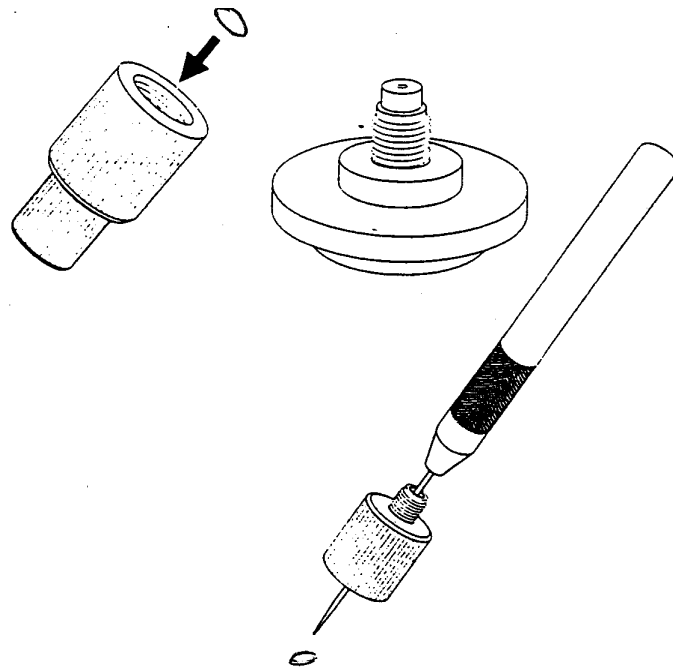

Figure 3. Installation and removal of rupture membrane.

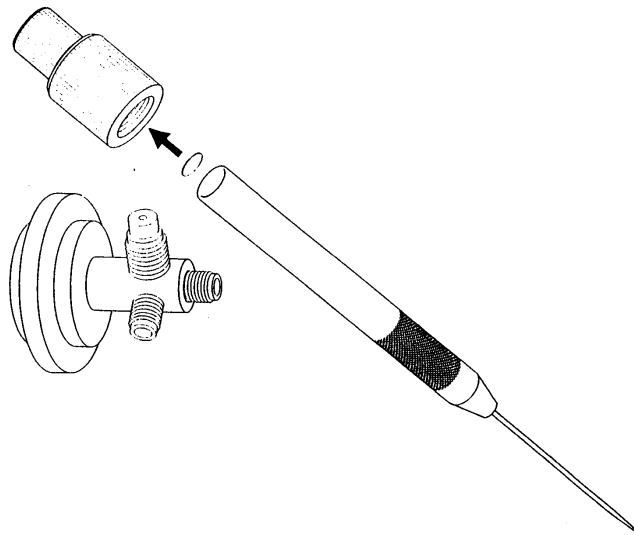

Figure 4. Installation of rupture membrane in vent fitting of advanced composite vessel with temperature/pressure control cover.

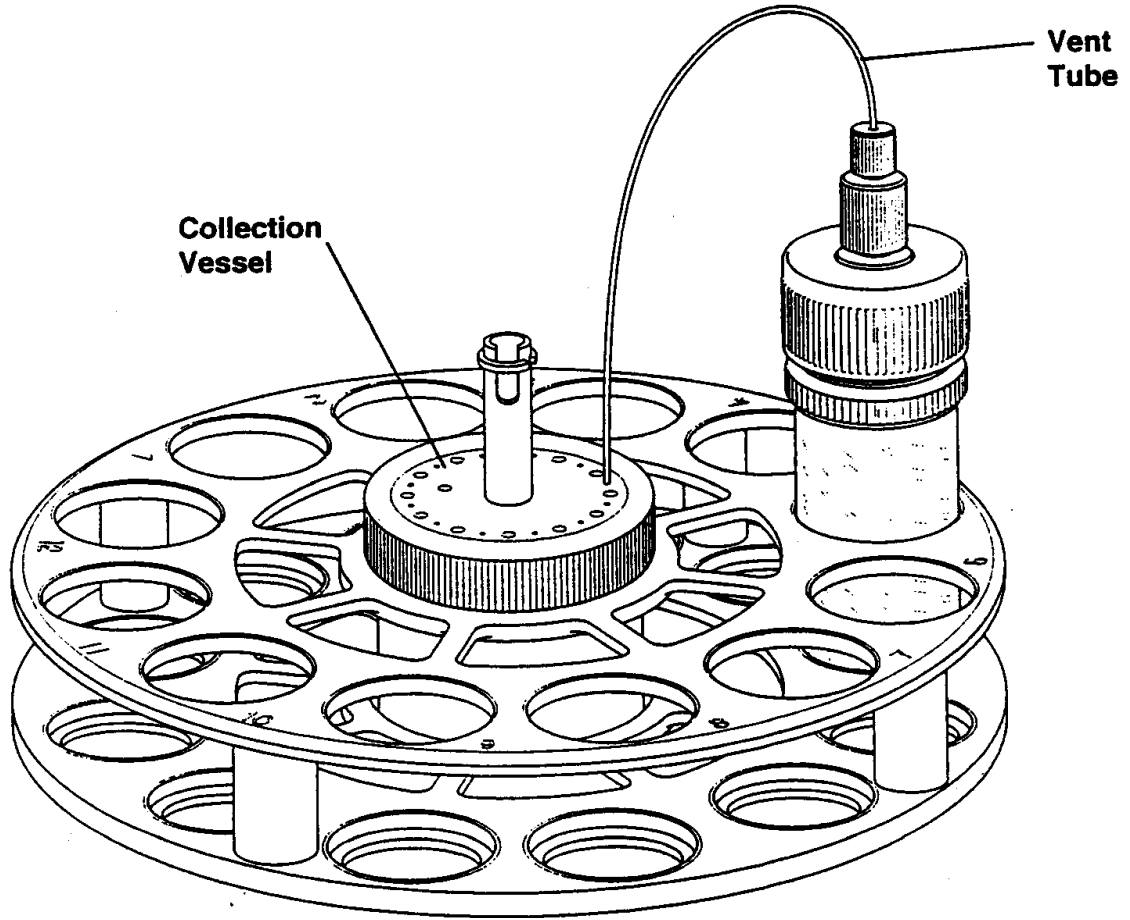

Figure 5. Routing of pressure sensing line and fiber optic temperature probe.

Protocol P-13-49

Preparation of Diatom Slides Using Naphrax™ Mounting Medium

Frank Acker, Benjamin Russell and Eduardo Morales

1. PURPOSE

- 1.1. Accurate identification and enumeration of diatoms requires mounting of cleaned material between a microscope slide and cover slip in a medium with a refractive index near that of glass, so that the features of diatom frustules or valves are clearly visible at high magnification. Naphrax™, a commercially-available toluene-based mounting medium with high refractive index, is currently used at the ANSP. This protocol details the steps necessary to produce high-quality diatom mounts from cleaned diatom material. This technique produces ‘permanent’ mounts, preserving the diatom specimens over many decades, at least.

2. SCOPE

- 2.1. Procedures described in this protocol include the dilution and dispersion of cleaned material onto glass cover slips, the mounting of cover slips onto glass microscope slides using Naphrax™ mounting medium, and the labeling of permanent mounts suitable for inclusion in the ANSP Diatom Herbarium.
- 2.2. This procedure applies to personnel involved with the preparation of diatom slides.

3. REFERENCES

- 3.1. American Public Health Association, American Water Works Association, Water Environment Federation (APHA, AWWA, WEF). 1992. Standard Methods for the Examination of Water and Wastewater. 18th ed.
- 3.2. Patrick, R. and C. Reimer. 1967. The Diatoms of the United States. Vol. 1. Monograph No. 13, Academy of Natural Sciences of Philadelphia, 688 pp.
- 3.3. PCER, ANSP. 1990. Laboratory Safety Manual.
- 3.4. U.S. Environmental Protection Agency. 1973. Biological Field and Laboratory Methods for Measuring the Quality of Surface Waters and Effluents. EPA-670/4-73-001. US. EPA Office of Research and Development. Cincinnati, OH.

4. SAFETY PRECAUTIONS

- 4.1. Personnel should be familiar with the information given in Reference 3.4.
- 4.2. Naphrax™ should be considered a hazardous substance because it contains toluene, an organic solvent. Toluene volatilizes readily when heated. For this reason, heating of Naphrax™ should only be performed under a positive-draw fume hood. Personnel should wear safety glasses and protective hand wear when working with liquid Naphrax™ at room

temperature, when heating Naphrax™ in a hood, or when in contact with solidified Naphrax™ toward the final stages of slide preparation.

- 4.3. Hot plate temperatures required for this procedure are high enough to cause severe burning of exposed skin. Use extreme care when manipulating slides on the hot plate and when working close to the hot plate.

5. APPARATUS/EQUIPMENT

- 5.1. Corning ceramic-top hot plate with temperature control.
- 5.2. Positive-draw chemical hood.
- 5.3. Aluminum drying plate (25.5 x 20.0 x 0.5 cm, solid aluminum; lines forming 48 squares, each 3.2 cm on a side, are etched on the surface. Each square is etched with an identifying number).
- 5.4. Glass microscope slides (1 x 3 inches; 2.5 x 7.5 cm)
- 5.5. Glass cover slips (18 mm x 18 mm) - No. 1 thickness, stored in covered glass jar filled with 100 % ethanol.
- 5.6. Naphrax™ mounting medium.
- 5.7. Diamond scribe.
- 5.8. Disposable plastic pipettes.
- 5.9. Adjustable pipettor (0 - 250 µl); adjustable pipettor (200 - 1000 µl).
- 5.10. Pipette tips for adjustable pipettors.
- 5.11. Round-style tooth picks.
- 5.12. Forceps.
- 5.13. Polished, rounded wooden splints.
- 5.14. Wash bottle filled with distilled (DW) or reverse osmosis (RO) water
- 5.15. Single-edged razor blades.
- 5.16. Ethanol, 70%.
- 5.17. Acetone.
- 5.18. Kimwipe® tissues.
- 5.19. ANSP slide labels.
- 5.20. Wax (the kind commonly used for candle making and canning foods).

6. METHODS

6.1. Estimate amount of cleaned diatom material to deposit on coverslip.

- 6.1.1. Starting with cleaned material contained within 20-ml glass vials, estimate the volume of suspended material that will need to be deposited (“dripped”) on a cover slip to produce a slide of the appropriate cell density. The ideal density to be achieved on the

final mount is somewhat subjective and is based on the amount of debris in the sample, the preferences of the slide analyst and the way in which the slide is to be used (e.g., counting, documentation). Generally, between 5 and 10 diatom specimens should be present in a single high power microscope field (1000X). To make the estimate, shake the cleaned material to ensure a homogeneous dispersion of cells within the 20-ml vial. Immediately open the vial and withdraw either a 25- or 50- μ l sub-sample using the 0- to 250 μ l adjustable pipettor. Place the subsample on a slide and cover it with an 18 x 18 mm cover slip. Then observe this preparation under a compound microscope at 50X magnification. Look at a number of fields and observe the density of cells. Then calculate the amount of material that would need to be dripped so that the density of cells seen at this magnification would be approximately 30 to 40 per field. This estimate is referred to as the “drip count” (the amount of cleaned material to be placed on a cover slip). Accuracy of estimates improves with experience. In many cases, analysts will request that both a “heavy” slide (~40 cells/field) and a “light” slide (~30 cells/field) be made. Record the “drip count” estimates on the “Diatom Lab - Slide Preparation Notes” form (Figure 1). When slidemaking is complete, record the estimates and final amounts dripped on the “Diatom Slide Preparation Form” (See Figure 2, Protocol P-13-48). Also note observations of interfering materials (sand, silt, etc.) on this form.

- 6.1.2. In some cases, the number of diatoms in a sample is very sparse. This is usually because diatoms were rare in the habitats sampled, or the sample bottles contain a small amount of material. In these cases, additional procedures are required to either make a satisfactory slide for analysis or to determine that analysis of a sample is not practical. Follow these procedures if more than about 900 μ l (this is the maximum amount that a coverslip can “hold” beneath it) would need to be dripped onto a coverslip to meet the above criteria.
 - 6.1.2.1. If a satisfactory slide could be made by increasing the concentration of cleaned diatom material by two to five times, then do this by using a micropipettor to remove the required amount water from the vial of material after it has been allowed to settle for at least eight hours. Record the concentration factor on the “Diatom Slide Preparation Form.”
 - 6.1.2.2. If a concentration of cleaned material greater than two to five times is required, then re-subsample the original sample (Protocol No. P-13-48). Take a subsample of a size sufficient to prepare satisfactory slides. Use all of the remaining sample only if absolutely necessary. Digest the subsample and prepare a new vial of cleaned material (Protocol P-13-42). Repeat procedure 6.1.1, above. If the concentration of cleaned material is still not sufficient, concentrate it, as described above. If still too dilute, combine the two vials of cleaned subsample materials. Record steps and volumes, and final concentration factor, on the “Diatom Slide Preparation Form.”
 - 6.1.2.3. If, after following the steps above to concentrate the cleaned material, the density of diatoms on a cover slip still does not meet the criteria of 30 to 40 cells per field at 400 - 450x magnification, then proceed to make the densest slide possible and take it to a diatom analyst to evaluate (the Phycology Section Diatom Taxonomy Coordinator at the ANSP). The analyst will make a determination of whether it is practical to analyze the sample. They will quickly scan the slide in its entirety under 100x magnification, and estimate the total number of

individuals on the slide. Then they will make their determination of whether the slide is countable, taking into account the density of diatoms, evidence of dissolution, and amount of debris (silt, clay, broken remains of diatoms and other siliceous organisms) that would make it difficult to identify specimens accurately. As a general guideline, if accurate identifications are possible, and at least 100 specimens could be counted within four hours, they should determine that the slide be analyzed; otherwise it should not. If the diatom analyst determines that the slide should not be counted, inform the Phycology Section Project Manager immediately. They will call the NAWQA study unit biologist that submitted the samples to inform them of the problem. Only under very special circumstances will an analyst be asked to take the extraordinary measure of counting a slide for a very long time (more than four hours). Record results of the diatom analyst's determination and rationale on the "Diatom Slide Preparation Form."

- 6.1.2.4. When doing their evaluation of a slide with few diatoms, as described in the step above, a diatom analyst may occasionally see evidence suggesting that a sample contains lightly silicified diatoms that may not have survived the digestion process. In these rare instances, they may suggest that a "burn mount" be made to determine whether diatoms did exist in the original sample. (This is one reason why a small portion of the initial sample should always be saved, even for phytoplankton.) The burn mount procedure was used extensively to create slides for diatom analysis before the introduction of methods incorporating acids for the digestion of organic material. Even though this method does not rid sample material entirely of organic debris, diatoms on the slide can at least be identified as diatoms. For this method, follow the EPA (1973) procedure. Briefly, a known portion of the untreated sample is dripped onto a coverslip and allowed to dry at room temperature. When the sample is dry, it is placed onto a hot plate and left for about 30 min at ca. 570°C. The coverslip is mounted according to procedure 6.3, below.

After it is prepared, have the burn mount slide examined by a diatom analyst. They will determine if diatoms are present and whether analysis of the slide is warranted. Slides prepared using the burn mount method can not be counted if too much organic material remains on the slide. This is because it is not possible to make accurate taxonomic identifications. Generally, burn mounts are used only as a last resort, and to confirm that weakly silicified diatoms are not present in the sample. Record information on all burn mount attempts, successful or unsuccessful, on the "Diatom Slide Preparation Form." Include at least date, name of preparer, volume of subsample used, and whether diatoms were observed.

- 6.2. **Deposit cleaned material on coverslip.** Use forceps to remove single 18 x 18-mm cover slips from the ethanol storage container, and carefully clean each by wiping with a Kimwipe®. Place each cover slip on a marked space of the aluminum drying plate. Be sure the aluminum drying plate is clean and dry to avoid cross-contamination. If the intended drip count is less than 600 µl, drip a small amount of distilled water onto the cover slip with a disposable pipette, sufficient to form a thin layer of water over the entire cover slip. Agitate the sample vial to a uniform dispersion and use the adjustable pipettor to quickly withdraw the required amount from near the central portion of the sample. Eject

this material smoothly and carefully onto the layer of distilled water already on the slip. By alternately drawing material up into the pipette and ejecting it, a homogeneous suspension is achieved on the cover slip. In the case where more than ~600 µl of original sample is required, the addition of distilled water is not necessary, and the sample can be ejected and mixed directly on the cover slip. In both cases, take care to ensure that the suspension covers the entire surface of the cover slip, including the extreme edges of the corners. Should the cover slip overflow, discard the cover slip, and repeat the procedure with a freshly cleaned cover slip. Discard the pipette tip when finished with each sample.

Once the aluminum drying plate is loaded with cover slip preparations, the plate should remain undisturbed until the cover slips are dry. At this point, drying of the slips can proceed at room temperature (a period of several hours will be required), or gentle heat (warm to the touch only) may be applied to hasten evaporation (a crook-neck lamp with incandescent light bulb placed 15 - 30 cm over the drying plate is one option). Once completely dry, put the aluminum plate with cover slips on the hot plate that has been preheated to 250 to 300°F. Leave for 3 to 5 minutes. This procedure ensures that nearly all water is driven from the material on the cover slips and helps assure that the diatom frustules will adhere to the surface of the glass. Remove the aluminum plate from the hotplate and inspect the cover slips. If the pattern of diatoms distributed on any of the cover slips is not even and smooth, they should be re-dripped. If cover slip distributions seem unsatisfactory after repeated attempts, consult an algal analyst.

6.3. Mount coverslip on microscope slide.

6.3.1. Using a diamond scribe, etch microscope slides with Sample ID, Subsample ID and Slide Replicate ID (e.g., GS029231 DT1 a).

6.3.2. Mount coverslip on slide.

THE FOLLOWING STEPS MUST BE PERFORMED IN A POSITIVE-DRAW FUME HOOD!

Using a rounded wooden splint or disposable pipette, transfer a small amount of Naphrax™ (volume equivalent to ~2 to 4 drops of water) to the central portion of the etched side of the microscope slide. Using a rounded wooden toothpick, distribute the Naphrax™ over an area approximately equivalent to the size of the cover slip. Then remove the appropriate cover slip from the aluminum plate with forceps, being careful to handle the cover slip only at the extreme corners. Invert the slip and place it gently on the Naphrax™ covered portion of the slide. Then place the slide (cover slip up) on the hotplate and apply gentle heat until the evolution of bubbles resulting from the evaporation of the toluene solvent first occurs, and then significantly diminishes. Remove the slide from the hot plate, and, using the rounded toothpicks, gently position the cover slip and press it to form a uniform, thin layer of Naphrax™ beneath the entire cover slip. Make sure that the edges of the cover slip are brought parallel to the edges of the microscope slide. Care must be taken at this stage not to press so hard as to damage or dislodge the diatoms or cause warping of the cover slip. As this procedure is taking place, the Naphrax™ is “setting up” (becoming hard), and the ability to move the cover slip will diminish rapidly. At this point, set aside the mount to finish cooling.

6.3.3. Use a single-edge razor blade to carefully trim any excess Naphrax™ which has been squeezed out from beneath the cover slip. Great care must be taken to avoid “lifting”

the cover slip by inadvertently allowing the edge of the blade to move between the cover slip and the microscope slide. Once most of the excess Naphrax™ has been removed and discarded, and while still working under the hood, place the mount in successive baths of acetone, and then ethanol for no more than 10 or 15 seconds each. Finally, wipe the mount clean with a Kimwipe® tissue.

- 6.4. **Add paper label to slides.** Either before or after slides have been analyzed, depending on project requirements, prepare paper labels and attach them to the mounts following the exact specifications and examples contained in Appendix 1. The standard labels produced by the Phycology Section include those for diatometer projects, surveys (hand collections), general projects (miscellaneous types), and the USGS NAWQA program. Contractors often submit slides with only etched labels; paper labels are added by Phycology Section staff.
- 6.5. **Enter data from the “Diatom Slide Preparation Form”.** Enter data directly into the following fields of the “Slide Information” table in the PHYCLGY database: Sample ID, Diatom Subsample ID, Slide Replicate ID, Vol Cleaned Material, D/C Factor, μ L dripped, Settled By (Worker ID), Mounted By (Worker ID), and Date Diatom Slide Completed.
- 6.6. **Assemble forms and transmit slides.** Put slides in plastic slide boxes; label each with name of project and subproject, Subproject ID, Box _ of _, date (month/year) box prepared, and name or initials of preparer. Sign and date the “Diatom Slide Preparation Form” and the “Diatom Lab - Slide Preparation Notes” form and put them in the “Diatom Analysis” folder. Print a “Diatom Slide Analysis Form” for use by the diatom analyst and add it to the “Diatom Analysis” folder also. Create this form using the “Diatom Analysis Form(...)” report in the PHYCLGY database. When slides are completed, transmit them and associated forms to the Phycology Section Project Manager, or inform them that slides are prepared.
- 6.7. **Preserve and store cleaned material.** After slides are analyzed according to the appropriate protocol, and no additional slides need to be made, process the vials containing the remaining acid-cleaned material for long-term storage. Working under a fume hood, add two - four drops of 100% buffered formalin to each vial (some contractors use alcohol as a preservative instead). Tightly cap the vials and seal them by immersing the top 1/3 of the vial in melted wax. Then transfer the vials to the appropriate storage cabinet in the Phycology Section for long-term storage. Be sure that the cabinet and shelves on which they are stored are properly labeled with the study unit year and Subproject ID. See the Phycology Section Project Manager for assistance.

7. QUALITY ASSURANCE/QUALITY CONTROL

- 7.1. This procedure was developed in the laboratories of the ANSP and has been used for the preparation of several thousand slides. Naphrax™ is produced under quality control conditions specifically for the purpose of high resolution slides (Northern Biological Supplies of Islip Great Britain). Naphrax™ mounts have proven to be stable over long periods (there are 25 plus year mounts in the ANSP Diatom Herbarium) and has been the mounting medium of choice of European investigations for over 40 years. Before it's production was halted in 1993, Hyrax™ was the most widely used commercially-available mounting medium and was used at the ANSP for many years before the switch to Naphrax™.

- 7.2. It should be understood that, given the microscopic size and large numbers of diatoms which are transferred from the cleaned material vials to the finished mount, there are a number of steps where contamination of the samples is possible. Laboratory rooms where raw or processed samples are handled should be kept as clean as possible. Laboratory bench surfaces should be kept clean and free of debris at all times. Techniques similar to those used for sterile experiments (bacteriological plating, etc.) should be followed to minimize the risk of cross-contamination of samples. All equipment coming into contact with sample material should be rinsed in DW or RO water at least three times. Disposable pipettes should be used when possible.
- 7.3. The distribution of specimens on the final mounted cover slips should represent the samples contained within the cleaned material vials. The degree to which this is true depends on how well the cleaned material is dispersed prior to sub-sample withdrawal, and how evenly the withdrawn material is dispersed on the cover slip. Great care should be taken to ensure that these two steps are completed properly.
- 7.4. For certain critical applications, the project protocol may call for duplicate slide sets to test for variation in quantitative data introduced by this procedure.

Diatom Lab - Slide Preparation Notes

Phycology Section

Patrick Center for Environmental Research

The Academy of Natural Sciences

1	1	2	2	3	3	4	4
5	5	6	6	7	7	8	8
9	9	10	10	11	11	12	12
13	13	14	14	15	15	16	16
17	17	18	18	19	19	20	20
21	21	22	22	23	23	24	24

Notes:

Dripped By:

Date Dripped:

Project Number & Name:

Figure 1. Diatom Lab - Slide Preparation Notes form.

APPENDIX 1

SLIDE LABEL FORMAT (ANSP DIATOM HERBARIUM)

Listed below are formats for slides labels for diatometer projects, surveys and special projects. Labels are 1 inch (2.54 cm) square and can accommodate 10 lines with 15 characters or spaces per line. Abbreviations should be used when necessary and clear.

I. Diatometer Projects

Line #1: State abbreviation, county name (or abbreviation)
e.g. SC, Allend. Co.

Line #2: Waterbody
e.g. Savannah River

Line #3: Station and substation code (diatometer code)
e.g. Sta: 1RC

Line #4: Installation date (exposure date)
e.g. exp: VIII-12-87

Line #5: Removal date
e.g. rem: VIII-26-87

Line #6: (nothing; assumes no particular collector)

Line #7: Project name
e.g. Sav Diatom. #35

Line #8: sides scrapped, microliters dripped
e.g. 6 sides 1500 μ l

Line #9: (nothing; reserved)

Line #10 preprinted Acad Nat Sci Philadelphia or ANS Phila.

Example:

SC, Allend. Co.
Savannah River
Sta: 1RC
exp: VIII-12-87
rem: VIII-26-87
Sav. Diatom. #35
6 slides 1500 μ l
ANS Phila.

II. Surveys (Hand Collections)

Line #1: State abbreviation, county name (or abbreviation)
e.g. TX, Victoria Co.

Line #2: Waterbody
e.g. Guadalupe River

Line #3: Station/substation/collection #
e.g. Sta 1L Coll: 19

Line #4 and
Line #5: Microhabitat
e.g. on rocks, gravel and sand

Line #6: Collection date
e.g. X11-10-1987

Line #7: Collector
e.g. Coll: RR Grant

Line #8: Survey name and number
e.g. Sav Cur Sur #96

Line #9: Microliters dripped
e.g. 1500 μ l

Line #10 preprinted Acad Nat Sci Philadelphia or ANS Phila.

Example: TX, Victoria Co.
Guadalupe River
Sta 1 Coll: 19
on rocks, gravel and sand
XII-10-1987
Coll: RR Grant
Sav Cur Sur #96
1500 μ l
ANS Phila.

III. General Projects (Miscellaneous)

- Line #1: State abbreviation, county name (or abbreviation)
e.g. PA, Wayne
OH, Clermont
- Line #2: Waterbody or installation
e.g. Swago Pond
P&G Art Streams
- Line #3: Station and substation or treatment
e.g. Treatment: NPC1
Stream 1, Rep 1
- Line #4: Microhabitat (if necessary)
e.g. nutrient pots
glass slides
- Line #5: Installation or collection dates (if applicable; exp = exposure date)
e.g. exp: VIII-11-87
VIII-31-87
- Line #6: Removal date (if applicable)
e.g. rem: VIII-31-87
- Line #7: Collector (if applicable)
e.g. JW Sherman
- Line #8 : Project name
e.g. POCONOS 1987-88
1988 P&G
ART. STREAMS
- Line #9: Sides scrapped, microliters dripped (if applicable)
e.g. 6 slides 1500 µl
- Line #10 preprinted Acad Nat Sci Philadelphia or ANS Phila.

Examples:

PA, Wayne	OH, Clermont
Swago Pond	P&G Art Streams
Treatment: NPC1	Stream 1 Rep 1
nutrient pots	glass slides
exp: VIII-11-87	VIII-31-87
rem: VIII-31-87	
Coll JW Sherman	1988 P&G
POCONOS 1987-88	Art Streams
6 slides 1500 µl	
ANS Phila.	ANS Phila.

IV. USGS NAWQA Program

Listed below is the format for slides labels for USGS NAWQA Program. Two labels are generated for each slide. One to be placed to the left of the coverslip and the other to be placed to the right of the coverslip. Abbreviations should be used when necessary and clear.

Left Label:

Line #1: State abbreviation, county name (or abbreviation)
e.g. WI, Milwaukee

Line #2: Waterbody
e.g. Lincoln Cr.

Line #3: Site Location ID
e.g. GS40869415

Line #4: Microhabitat (if necessary)
e.g. nutrient pots

Line #5: Collection dates
e.g. 5/15/95

Line #6: Collector (if applicable)
e.g. B. Scudder

Line #7: USGS NAWQA

Line #8: USGS NAWQA Sample ID
e.g. WMIC0595ARE0001B

Line #9: ANSP Slide ID
e.g. GS004503-DT1-b

Example:

WI, Milwaukee
Lincoln Cr.
GS40869415

5/15/95
B. Scudder
USGS NAWQA
WMIC0595ARE0001B
GS004503-DT1-b

Right Label:

Line #1: ANSP Diatom Herbarium Accession Number
e.g. 100001b

Lines # 2 through #7: Reserved for names of taxa found on the slide (if applicable)

Line #8: Determiner (If applicable)

Line #9: ANSP

Protocol P-13-50
Preparation of USGS NAWQA Program Algal Samples
for Analysis Using Palmer-Maloney Cells

Frank Acker

1. PURPOSE

- 1.1. Quantitative algal samples collected by the U.S. Geological Survey's (USGS) National Water-Quality Assessment Program (NAWQA), including Richest Targeted Habitat (RTH) and Depositional Targeted Habitat (DTH), must be prepared prior to taxonomic analysis. The purpose of this procedure is to produce a fraction (small volume of sample) with a concentration suitable for analysis with the Palmer-Maloney counting cell.

2. SCOPE

- 2.1. This procedure is applicable to quantitative samples collected by the USGS NAWQA program. Fractions for analysis of periphyton samples collected with similar protocols (e.g., collections from natural substrates) can also be made using these procedures.
- 2.2. This procedure applies to personnel responsible for preparing algal fractions from soft-algae subsamples of original samples (e.g., see ANSP Protocol P-13-48). These fractions are used for taxonomic analysis of soft-algae, for analysis using a Palmer-Maloney counting cell, and for estimating the total number of diatom frustules (cells) in samples.

3. REFERENCES

- 3.1. Palmer, C.M. and T.E. Maloney. 1954. A new counting slide for nanoplankton. American Society of Limnology and Oceanography Special Publication Number 21. 6 pp.
- 3.2. United States Geological Survey (USGS), National Water-Quality Assessment Program (NAWQA). 1997. Procedures for Processing NAWQA Algal Samples. Draft Manuscript. February 1997.

4. APPARATUS/EQUIPMENT

- 4.1. Formalin solution, 2%.
- 4.2. Scissors, small stainless steel.
- 4.3. Blender with small volume (20 ml) attachment.
- 4.4. Vials, 20 ml, scintillation or flint glass.
- 4.5. Diamond scribe.
- 4.6. Palmer-Maloney counting cell.
- 4.7. Pre-printed bench sheet, "USGS NAWQA Palmer-Maloney Fraction Preparation Bench Sheet" (Figure 1).

5. DEFINITIONS

- 5.1. **Natural counting unit.** Each natural grouping of algae (i.e., each individual filament, colony, or isolated cell) is defined as a natural counting unit. Diatoms are an exception; each diatom cell is always considered a natural counting unit, even if attached to other cells. The main purpose of using ‘natural counting units’ is to prevent a colonial or filamentous form from dominating a count. It also facilitates the counting of algal forms which have linked cells that may be hard to distinguish.
- 5.2. **Formalin.** Due to the flammability of concentrated formaldehyde, standard maximum strength solutions are 37% formaldehyde; 100% formalin by definition is this standard 37% formaldehyde. Thus, 2% formalin is a 2% solution of the standard formaldehyde solution, not 2% formaldehyde.
- 5.3. **Dilution liquid.** Samples collected as part of many sampling programs, including NAWQA, are preserved with a 4-5% formalin solution. Dilution liquid refers to the 3-5% formalin solution added to fractions when it is necessary to make dilutions of these fractions.

6. METHODS

- 6.1. If there are visible macro forms in the soft-algae subsample (i.e., visible filaments or colonies), break them up using scissors or small blender. This does not include maceration or grinding. The purpose of this step is to suspend algae so that fractions will have proportions of algal taxa equal to those in the original sample.
- 6.2. Determine the amount of dilution or concentration required. Ideally, in a Palmer-Maloney cell at 350-450x magnification, there should be about 15-30 cells or natural units in a field of view. Take into account that interfering materials (sands, silt, etc.) may reduce the number of cells that can be observed; reduce cell concentration accordingly. Estimate the amount a sample must be diluted or concentrated, based on visual observation. Accuracy improves with experience.
- 6.3. Record the fraction volumes for each separate fraction on the “USGS NAWQA Palmer-Maloney Fraction Preparation Bench Sheet” form (Figure 1). The Palmer-Maloney dilution/concentration factor will be greater than 1 if subsample material was diluted when making the Palmer-Maloney fraction, and less than 1 (though positive) when subsample material was concentrated to make the fraction.
- 6.4. A note about fraction naming convention. A “Palmer-Maloney Fraction ID” is given to each physical fraction that is created. The original subsample is defined as fraction “a.” If the subsample is concentrated and remains as one physical fraction, the fraction remains as “a.” However, for most cases of dilution, a second or third physical fraction is produced and they are defined sequentially as “b,” “c,” ...
- 6.5. To dilute an aliquot, add a volume of dilution liquid to an aliquot from the subsample. Thoroughly mix the subsample and measure an aliquot in a small graduated cylinder. Place this portion of the subsample in a clean 20-ml scintillation vial. Add a measured volume of dilution liquid and mark the vial as fraction “b” (each fraction vial is scribed with Sample

ID, Subsample ID and Palmer-Maloney Fraction ID). If more dilution is necessary, repeat this step to produce a “c” fraction.

- 6.6. To prepare a concentrated aliquot, place the entire measured subsample in a 50-ml centrifuge tube. Centrifuge for 20 min at 1000 g. Siphon off the supernatant and measure the volume of remaining subsample. Return the remaining subsample to its original vial. This fraction remains fraction “a.” If a more concentrated fraction is needed, subsample a larger amount and centrifuge in a similar manner. When additional subsamples are used, the concentrated subsamples are combined into one fraction (fraction “a”). Note the total volume of the subsamples and the volume of the fraction. Information on additional subsamples needs to be recorded on the “NAWQA Sample Volume/Subsample Form” and entered in the “Subsample Information” table in the PHYCLGY database.
- 6.7. Record fraction volumes and calculated dilution/concentration factors on the “USGS NAWQA Palmer-Maloney Fraction Preparation Bench Sheet.” For fraction “a,” record the original amount of subsample (this volume will later be compared with subsample volume that was entered in the “Subsample Information” table as a QC check to make sure values are the same). Record the volume in the vial after any concentration (or dilution) as the fraction volume (i.e., volume of PR1-a). For the other fractions, (i.e., fraction “b” and “c”), record the volume of the fraction added to the new vial and the total volume of the fraction, after dilution. Calculate a factor for each fraction by dividing the total volume of the fraction by the volume taken from the originating fraction (or subsample for fraction “a”). To get the dilution/concentration (d/c) factor for each fraction, multiply this fraction factor by the d/c factor for all preceding fractions.
- 6.8. Enter data from the “USGS NAWQA Palmer-Maloney Fraction Preparation Bench Sheet” directly into the PHYCLGY database table “Palmer-Maloney Fractions.” Create one record for each physical fraction, including the “a” fractions that were not diluted or concentrated. Add the completed bench sheet to the “Soft-Algae Analysis” folder. Tables 1 and 2 explain the process.

7. QUALITY ASSURANCE AND QUALITY CONTROL

- 7.1. It is critical that prior to taking a small portion of the subsample, the sample be thoroughly mixed (section 6.5) and macro or visible forms are evenly dispersed (section 6.1). A small portion of the subsamples from each group of samples (i.e., study unit) is re-processed using final dilution/concentration factors and checked for number of natural units per microscope field.
- 7.2. Minor deviations to this protocol are expected, especially concerning methods to break up algal clumps. These deviations should be reported to project managers and/or algal taxonomists and noted on the “USGS NAWQA Palmer-Maloney Fractions Preparation Bench Sheet” form.

Table 1. Soft-algae dilutions - Definitions of fields in the Palmer-Maloney Fractions table.

<i>Field</i>	Description	Rules
Sample ID	The identification assigned at the ANS to the sample. Starts with "GS" and includes the bottle number.	Required for all samples.
SubSample ID	The identification assigned to the SubSample. Starts with "PR" for periphyton subsamples and "PP" for phytoplankton subsamples.	Required for all samples.
P-M Fraction ID	The identification assigned to the Palmer-Maloney fraction. The values can only be a, b, c, or d.	Required for all samples.
Fraction Vol (ml)	The volume (in ml) of the fraction after any dilution or concentration.	Required for all samples.
D/C Factor	The dilution / concentration factor used to equate the fraction volume to the subsample volume.	Required for all samples.
Worker ID	The identification assigned to the person who prepared the P-M fractions. Codes are numeric and can be found in the "Workers" table of the PHYCLGY database.	Required for all samples.
Date P-M Fraction Prepared	Date when preparation of the P-M fraction was completed.	Required for all samples.
Verified By	The identification assigned to the person who verified the data entry of the P-M fraction data.	Entered during data verification.
Date Verified	Date when P-M fraction data was verified as complete and correct.	Entered during data verification.

Table 2. How to enter data into the “Palmer-Maloney Fractions table” from the “Palmer-Maloney Fraction Preparation Bench Sheet.”

Fields in the Palmer-Maloney Fractions table					
P-M Fraction	Sample ID	SubSample ID	P-M Fraction ID	Fraction Vol (ml)	D/C Factor
a	The Sample ID from the bench sheet (“GS...”).	The SubSample ID from the bench sheet (“PR1”).	The fraction ID from the bench sheet (e.g., a, b, or c).	Volume 2	D/C Factor 4.
b				Volume 6	D/C Factor 8.
c				Volume 10	D/C Factor 12.

fraction a		fraction b		fraction c	
GSN____-PR1-a		GSN____-PR1-b		GSN____-PR1-c	
volume of subsample	1 ____	volume of PR1-a	5 ____	volume of PR1-b	9 ____
volume of PR1-a	2 ____	volume of PR1-b	6 ____	volume of PR1-c	10 ____
PR1-a/subsample	3 ____	PR1-b/PR1-a	7 ____	PR1-c/PR1-b	11 ____
fraction “a” D/C Factor	4 ____	fraction “b” D/C Factor	8 ____	fraction “c” D/C Factor	12 ____

1. Volume 1. Volume subsampled from the original sample.
2. Volume 2. Volume of Palmer-Maloney fraction “a” after any dilution or concentration.
3. Calculation 3. The dilution or concentration for fraction “a” (Volume 2 / Volume 1).
4. D/C Factor 4. The D/C Factor for fraction “a” (equals Calculation 3).
5. Volume 5. Volume subsampled from Palmer-Maloney fraction “a”.
6. Volume 6. Volume of Palmer-Maloney fraction “b” (Volume 5 + volume added).
7. Calculation 7. The dilution or concentration for fraction “b” (Volume 6 / Volume 5).
8. D/C Factor 8. The D/C Factor for fraction b (D/C Factor 4 * Calculation 7).
9. Volume 9. Volume subsampled from Palmer-Maloney fraction “b”.
10. Volume 10. Volume of Palmer-Maloney fraction “c” (Volume 9 + volume added).
11. Calculation 11. The dilution or concentration for fraction c (Volume 10 / Volume 9).
12. D/C Factor 12. The D/C Factor for fraction “c” (D/C Factor 8 * Calculation 11).

USGS NAWQA Palmer-Maloney Fraction Preparation Bench Sheet

fraction "a"	fraction "b"	fraction "c"
GSN _____ -PR1-a volume of subsample _____ ml volume of PR1-a _____ ml PR1-a/subsample _____ fraction "a" D/C factor _____	GSN _____ -PR1-b volume of PR1-a _____ ml volume of PR1-b _____ ml PR1-b/PR1-a _____ fraction "b" D/C factor _____	GSN _____ -PR1-c volume of PR1-b _____ ml volume of PR1-c _____ ml PR1-c/PR1-b _____ fraction "c" D/C factor _____
GSN _____ -PR1-a volume of subsample _____ ml volume of PR1-a _____ ml PR1-a/subsample _____ fraction "a" D/C factor _____	GSN _____ -PR1-b volume of PR1-a _____ ml volume of PR1-b _____ ml PR1-b/PR1-a _____ fraction "b" D/C factor _____	GSN _____ -PR1-c volume of PR1-b _____ ml volume of PR1-c _____ ml PR1-c/PR1-b _____ fraction "c" D/C factor _____
GSN _____ -PR1-a volume of subsample _____ ml volume of PR1-a _____ ml PR1-a/subsample _____ fraction "a" D/C factor _____	GSN _____ -PR1-b volume of PR1-a _____ ml volume of PR1-b _____ ml PR1-b/PR1-a _____ fraction "b" D/C factor _____	GSN _____ -PR1-c volume of PR1-b _____ ml volume of PR1-c _____ ml PR1-c/PR1-b _____ fraction "c" D/C factor _____
GSN _____ -PR1-a volume of subsample _____ ml volume of PR1-a _____ ml PR1-a/subsample _____ fraction "a" D/C factor _____	GSN _____ -PR1-b volume of PR1-a _____ ml volume of PR1-b _____ ml PR1-b/PR1-a _____ fraction "b" D/C factor _____	GSN _____ -PR1-c volume of PR1-b _____ ml volume of PR1-c _____ ml PR1-c/PR1-b _____ fraction "c" D/C factor _____
GSN _____ -PR1-a volume of subsample _____ ml volume of PR1-a _____ ml PR1-a/subsample _____ fraction "a" D/C factor _____	GSN _____ -PR1-b volume of PR1-a _____ ml volume of PR1-b _____ ml PR1-b/PR1-a _____ fraction "b" D/C factor _____	GSN _____ -PR1-c volume of PR1-b _____ ml volume of PR1-c _____ ml PR1-c/PR1-b _____ fraction "c" D/C factor _____

Prepared By: _____ (____) __/__/200_ Entered By: _____ (____) __/__/200_ Confirmed By: _____ (____) __/__/200_

Figure 1. USGS NAWQA Palmer-Maloney fraction preparation bench sheet.

Protocol P-13-39

Analysis of Diatoms on Microscope Slides Prepared From USGS NAWQA Program Algae Samples

Todd Clason, Frank Acker, Eduardo Morales, and Lont Marr

1. PURPOSE

- 1.1. The U.S. Geological Survey's (USGS) National Water-Quality Assessment Program (NAWQA) collects four kinds of algae samples analyzed by the Phycology Section of the Patrick Center for Environmental Research, ANSP. These include Richest Targeted Habitat (RTH), Depositional Targeted Habitat (DTH), Qualitative Multihabitat (QMH), and phytoplankton samples (Porter et al., 1993; Moulton et al., 2002). This protocol describes procedures for analyzing diatoms on microscope slides made from all four types of NAWQA algae samples.
- 1.2. The purpose of RTH and DTH sample analysis is to estimate the proportion of diatom taxa found in a count of 600 valves (one-half of an individual diatom cell). Results are later combined with those from analysis of the soft-algae component of the same sample (Protocol P-13-63) to provide data on algal densities (as cells per cm² of sampling surface) and amount of algal biovolume (μm^3 per cm² of sampling surface) at a sampling site.
- 1.3. "The purpose of QMH sample analysis is to identify as many taxa present in the sample as possible, to provide an accurate and uniform estimate of algal taxa richness in a stream reach. An underlying assumption is that although all algal taxa present in a sample (or on a slide prepared from a sample) will not be identified, most species will be found during a reasonable search. If that effort is consistent among taxonomists, results from analyses of samples and slides will be comparable among analysts and contract laboratories" (Porter 1994). Unlike an RTH and DTH count, the number of diatoms to be counted is not fixed. Instead, the analyst scans the slide until the rate at which new species are encountered, per 100 specimens observed, drops below a defined number, or a time limit is reached.
- 1.4. The purpose of phytoplankton sample analysis is similar to that of RTH and DTH samples, except that the quantitative results are expressed in number of cells per volume of water. Phytoplankton samples are collected from the water column, using various sampling techniques and collection devices.

2. SCOPE

- 2.1. This protocol covers the identification and enumeration of diatom taxa mounted on microscope slides. Two alternative procedures are described for recording data: 1) use of the "Tabulator" program (Cotter 2002), and 2) writing on bench sheets followed by data entry directly into database tables or through use of the "DtmCnt" program. As of summer 2001, all NAWQA diatom analysts use the "Tabulator" program. For this reason, the primary methods described here pertain to analyses made using "Tabulator." The only section relating to the "bench sheet" approach lists the data fields that must be entered into the database for each analysis. Most of the instructions for using "Tabulator" are in the

User's Guide (Cotter 2002). Some of those instructions are summarized here to provide an overview of the program and to help clarify how it is used in the process of analyzing NAWQA samples. Procedures not included in the "Tabulator" manual are described here.

- 2.2. This procedure is applicable to the analysis of diatoms in algae samples collected by the RTH, DTH, QMH, and phytoplankton sampling protocols of the USGS NAWQA program.
- 2.3. Personnel responsible for these procedures include diatom analysts and data entry personnel.
- 2.4. In March 2002, the previous version of this Protocol (RTH and DTH samples only) was merged with Protocol P-13-61, which described procedures for analysis of NAWQA QMH samples.

3. REFERENCES

- 3.1. Cotter, P. 2002. "Tabulator" Installation and User's Guide. Version 3.51. ANSP, PCER.
- 3.2. Moulton, S.R., II, J.G. Kennen, R.M. Goldstein, J.A. Hambrook. 2002. Revised protocols for sampling algal, invertebrate, and fish communities in the National Water-Quality Assessment program, U.S. Geological Survey Open-File Report 02-150. In Press.
- 3.3. PCER, ANSP. 2002. Diatom Cleaning by Nitric Acid Digestion with a Microwave Apparatus. Protocol No. P-13-42.
- 3.4. PCER, ANSP. 2002. Analysis of Soft Algae and Enumeration of Total Number of Diatoms in USGS NAWQA Program Quantitative Targeted-habitat (RTH and DTH) Samples. Protocol P-13-63.
- 3.5. PCER, ANSP. 2002. Preparation of Diatom Slides Using Naphrax™ Mounting Medium. Protocol No. P-13-49.
- 3.6. Porter, S.D. 1994. Amendment to Guidance, Procedures, and Specifications for Processing NAWQA Algal Samples by Contract Laboratories. Email contract reference of 10/19/1994 from Stephen Porter to Allison Brigham of the USGS, Ann St. Armand of Phycotech, Don Charles and Frank Acker of the Academy of Natural Sciences.
- 3.7. Porter, S.D., T.F. Cuffney, M.E. Gurtz, M.R. Meador. 1993. Methods for Collecting Algal Samples as Part of the National Water Quality Assessment Program. U.S. Geological Survey Open-File Report 93-409, Raleigh, NC [39 pp]
http://water.usgs.gov/nawqa_home.html.
- 3.8. United States Geological Survey, National Water-Quality Assessment Program. 1997. Protocols for Processing NAWQA Algal Samples. Draft Manuscript. February 1997.

4. APPARATUS/EQUIPMENT

4.1. Compound microscope:

- 4.1.1. Oil immersion objective (100x) with a numerical aperture of at least 1.3;
- 4.1.2. Eyepieces of 10-15x;
- 4.1.3. DIC (differential interference contrast) or bright field condenser;

4.1.4. Diamond scribe mounted on microscope's objective stage;

4.1.5. High intensity light source.

4.2. **Desktop computer (located at microscope if "Tabulator" program is used):**

4.2.1. Pentium II or higher processor;

4.2.2. Software: "Tabulator" or "DtmCnt" programs by Patrick Cotter (MS Visual Basic);

4.2.3. Network connection to ANSP Phycology Section databases (ANSP staff only).

5. METHODS

5.1. Diatom counts.

5.1.1. Review the "Diatom Slide Preparation Form" and the "Diatom Slide Analysis Form" (Figure 1) contained in the "Diatom Analysis" folder and transmitted with the diatom slides from the Diatom Preparation Lab. The "Diatom Slide Analysis Form" lists sample information for each slide it accompanies, and provides space next to each listed slide to initial and date when a count is finished. It also serves as a chain-of-custody record; it must be signed by the person delivering the slides and the person receiving them. Make sure that the slides correspond with the entries on the form. Note and resolve any discrepancies.

5.1.2. Scan slides at low to medium magnification (100x to 450x) to confirm that diatoms are evenly distributed on the coverslip, and are at a density appropriate for efficient counting. At high magnification (1000x), there should be between 5-10 diatoms per field. If there are problems with dispersion or density that would compromise the quality and accuracy of the analysis, discuss these with Diatom Preparation Lab personnel and have new slides made. Avoid counting diatoms in any disrupted areas of the mount, particularly edges that have optical aberrations. If diatoms on the slides are very sparse, refer to procedures in Protocol No. P-13-49 for handling low-density samples. Always save any count data generated for a sample, even if the number of valves or frustules is low (e.g., <100).

5.1.3. Because slides may need to be recounted for QA/QC purposes, it is very important to clearly demarcate the areas of a slide scanned during a count. After the preliminary slide examination, secure the slide in the mechanical stage and use the microscope's diamond scribe to etch a horizontal or vertical line (depending on personal preference) on the coverslip to mark the edge of the first row to be counted. Rows are narrow rectangular areas (strips) of the slide adjacent to the scribed line, with width equal to the field of view. Start rows far enough from the coverslip edge to avoid optical distortion, and end them near the opposite coverslip edge where diatoms are no longer clearly visible (see diagram below). Locate a starting point near one end of the etched line and make a circle with the scribe. This denotes the starting point of the count. During the count, etch a circle around the last field counted in the first row and at the beginning and end of all other rows. Always check to make sure that etching is clearly visible so that circles and lines can be located easily by others.

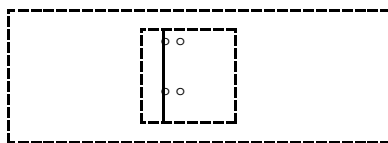

- 5.1.4. When the line and first field are etched on the coverslip, and the first field is focused under oil immersion, begin using the “Tabulator” program, following the instructions in the manual; some steps are summarized below. After opening the program, the first screen encountered is the Count Information page. Click the “New” button along the bottom edge of the page. Most fields will automatically fill with default information if this is not the first slide in the subproject to be counted; otherwise data must be added. Enter data in the fields in the “Slide” box at the top of the form. Click the “Verify Slide” button to reconfirm that the slide information is in the database. Fill in the other fields in the form, including “Frustules or Valves” and “Count Type.” For RTH and DTH samples, choose “Valves” and then “600 valves (300 cells).” For QMH samples, choose “Frustules” and then “NAWQA Qualitative (diatoms).” (Note that the selection in the “Frustules or Valves” box determines the choices available in the “Count Type” box). Click the “Save” button.
- 5.1.5. After the preliminary information is recorded, click the “Count Now” button. Several small text boxes are displayed to confirm data entry, and then the main “Tabulator” page appears. Before counting can proceed, select a taxa list from the bottom right “Choose List” box. The “Tabulator” manual describes how to create new lists and add new taxa to existing lists.
- 5.1.6. Before beginning the count, click the “Note” box in the central portion of the “Tabulator” window and record the start circle coordinates (numbers on the microscope stage). Coordinates of the first (and last) field of each row should be recorded immediately after they are scribed using the following format: “Row 1 x35.2, y87; y95; Row 2” etc. The x coordinate should only be recorded once for each row.
- 5.1.7. As the count commences, enter taxa observed using the discrete three-digit codes established during the taxa list building process. Enter codes with the numeric keypad on the computer keyboard. Record multiple examples of a single taxon either with code: “322 +10 enter,” for example; or by repeated hits of the enter key “322 enter, enter, etc.” Taxa may also be subtracted by typing the taxon code, followed by a minus sign and the number to be subtracted: “322 –1 enter,” for example. The program will signal an alert when the count total, as established by the count type, is reached (quantitative counts only).

On average, analysis of a slide should take approximately two hours; in no case should it exceed four hours. This does not include time spent learning new taxa when analyzing the first few samples in a new study unit.

- 5.1.7.1. RTH and DTH analysis. Count 600 valves. Count all partial valves that are more than 50% of the valve or that contain unique features such as recognizable central areas or distinct ends. Count all valves and fragments that extend at least halfway into the field of view.
- 5.1.7.2. QMH analysis. The stopping rule for QMH samples is: “Taxa found on semi-permanent slides are examined and identified in intervals (groups) of 100 frustules or valves. When examining the first interval of 100 individuals,

determine if any taxon constitutes 40 percent or more of the total. Such predominant taxa should not be tallied in subsequent intervals. Examine a minimum of 10 intervals (1000 individuals). Continue scanning intervals until two consecutive intervals have been completed in which two or fewer new taxa are encountered. It is unnecessary to scan more than 50 intervals (5000 individuals) per sample. Record the number of intervals scanned on the laboratory data sheet” (Porter 1994).

Use the following procedure for counting QMH samples with the “Tabulator” program. Count the first interval as if it were a regular RTH or DTH sample. That is, record in “Tabulator” the occurrence of each frustule viewed under the microscope. Once the first 100 hundred frustules have been counted, generate an on-screen report for the count by going to the File menu on the “Tabulator” screen and selecting Print Count. From this report, determine if any taxa in the first interval equaled or exceeded a relative abundance of 40%. Exclude these taxa from the remainder of the analysis. Close the on-screen report. Starting with the second interval, keep track of the number of frustules by using a hand counter. Record occurrence of a new species (species not encountered in the first interval) in “Tabulator” only once, the first time it is encountered. Each time an interval is finished, type “r” and then hit enter on the keyboard to proceed with the next interval. A message will appear: “Are you sure you want to end this interval?.” Hit yes. “End Row ?” (where “?” is the number of the row just completed), will then appear in the “Count Entries” window. If the 9th and 10th intervals contain two or fewer new taxa, then stop the analysis at the end of the 10th interval. Otherwise, continue the analysis until 2 consecutive intervals are found for which no more than 2 new species are recorded, up to a maximum of 50 intervals (5000 frustules).

- 5.1.8. When the count is finished, return to the Count Information page to complete the boxes “Date Count Finished,” “Scan Length,” and “Hours To Complete.” Then return to the “Tabulator” window and print a “Count Report” and check it carefully for errors. Make adjustments, if necessary, print a final copy, sign it, and put it in the “Diatom Analysis” folder. In “Tabulator,” select “Save Count” from the “File” menu in the top left of the “Tabulator” window. This saves the count to the underlying database. If the count data are not saved before exiting “Tabulator,” the information will be retained by the program but not added to a database. To save the data if this occurs, reopen the “Tabulator” program, enter the required information about the sample, click “Count Now” to get to the “Tabulator” window, and select “Save Count” from the “File Menu.”

Put initials and date on the “Diatom Slide Analysis” form next to the entry for the slide just counted. Return it and any other related forms to the “Diatom Analysis” folder. Clean slides of immersion oil with alcohol. When finished analyzing all slides in a subproject, give the slides and “Diatom Analysis” folder to the Phycology Section Project Manager.

5.2. Biovolume measurements.

- 5.2.1. NAWQA sample analysis requires biovolume measurements for each taxon occurring in abundance of 5% or more in any one sample in a study unit. Criteria for determining how many measurements to make of each taxon for each NAWQA study unit changed slightly from the beginning of algal analyses (1995). The basic rule, as originally specified by NAWQA, was to make 15 sets of measurements. As the number of measurements for taxa accumulated, however, the criterion was changed. Since 1999, only 5 additional sets of measurements are required for taxa in new study units if the range of those 5 sets falls within the range of all previous measurements from other study units. If the ranges do not overlap, make a full 15 measurements for the taxon. Biovolume measurements can be made during the routine process of counting slides or after all slides for a Subproject have been counted. It is likely that criteria for selecting specimens to measure will evolve as the number of measurements for common taxa accumulates.
- 5.2.2. Use the form “frmBiovolumeVerification” in the PHYCLGY database to determine which taxa occur in abundance of 5% or more in samples in a subproject, and therefore must be measured. The form also shows the number of measurements that are already entered in the database, and minimum, maximum and average biovolumes. Print the results. To find which slides contain the most specimens of the taxa to be measured, use the query “qryfind=>5% taxa.” Print the results. Both of the above printouts should be included in the Diatom Analysis folder.
- 5.2.3. Use the Biovolume Calculation feature of “Tabulator” as a convenient means for calculating and entering biovolume data directly into the NADED database (ANSP staff) or the “Tabulator” back-end database (subcontractors). The BioVol program can also be used. It is essentially a stand-alone version of the “Biovolume Calculation” feature in “Tabulator.” It is located in G:\Phycdata\VBAppInstalls\BioVol.

Choose the first microscope slide with taxa to be measured, open the “Tabulator” program, and enter the “Slide ID.” Select the “Find Counts” and “Count Now” buttons, and make the choices necessary to get to the “Tabulator” screen. Select “Biovolume Calculation” from the Documentation menu at the top of the “Tabulator” screen. The fields labeled Sample ID, Subsample ID, Slide Replicate ID, Microscope, Lens, and Conversion Factor are automatically filled with information for the slide you entered. Drop-down boxes can be used to modify any of this information if needed. The Microscope ID, Lens ID and Conversion Factor fields are linked. As soon as a given Microscope and Lens are selected from the drop-down box, a conversion factor for that microscope is shown in the Conversion Factor field. Since conversion factors are already stored in a database table accessible to the “Tabulator” program, and they are used in the calculation of biovolumes, it is extremely important NOT to make any conversion in the measurements before entering them in the required field of the Biovolume Calculations form. Simply enter readings from your ocular scale directly and as they are!

Enter the NADED Taxon ID for the specimen being measured. The taxon name field will fill-in automatically. Then select the correct shape for the taxon. If it is already filled-in, make sure it is correct. Consult the Biovolume Measurements table in NADED as a reference source for assigning shapes. The table contains shape codes

that have been assigned to taxa in the past. The shape specifies a specific formula to be used to calculate biovolume. The measurement fields that must be filled-in for that shape will appear on the form. Be sure to enter data for all required dimensions.

The number of measurements made for a taxon are shown in the field labeled “# of Measurements this session.” If measurements must be corrected, click the “Datasheet” button at the bottom of the form and make changes in the appropriate record. After all measurements for a taxon have been entered, press the “New taxon” button at the bottom left of the form to begin the process with a different taxon. When ready to go to a new slide to make measurements, enter new data in the “Slide” box and follow same steps described above.

The Biovolume Summary window is a useful feature for keeping track of measurements and to check that all have been made for a study unit. It is also useful for comparing measurements for a taxon with all others made for that taxon. It is accessed through the “Edit” menu on the top left of the Biovolume Calculation window. Select a subproject in the central menu, click the “Diatom” button to the right, and all taxa requiring biovolume measurements are displayed. Single taxa can be selected and double clicked to display biovolume measurements for that taxon over all subprojects. This is helpful for determining whether averages of current measurements fit in the ranges determined for that taxon in other study units. Again, reviewing data at this level can prevent significant errors.

5.3. Specimen documentation.

- 5.3.1. Requirements for documenting diatom species vary with subproject. In general, circle new, unknown, unusual and outstanding diatom specimens with a diamond scribe and image them photographically or with a digital device. This allows comparison with reference specimens and facilitates examination by specialists. Use the following two features, accessible from the Tabulate screen, to assist with documentation.
- 5.3.2. Circle specimens. Click the “Circle” button in the “Tabulation” box in the “Tabulator” window to activate the New Circle on Slide window. Values that appear in the fields for Taxon name, Microscope, Date, and Circler default from the “Tabulator” screen. Enter the Circle Number, Horizontal and Vertical Coordinates (from microscope stage), and both Cover Slip Sector (1-16) and Circle Sector (1-9) (see illustrations). These all help document the circle and specimen location. Record extra information concerning the documentation in the “Note” box, if necessary. You can click the “Datasheet” button to review records for existing circles.

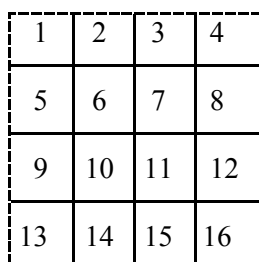

Cover Slip Sector

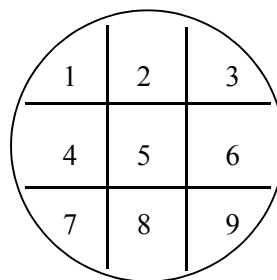

Circle Sector

- 5.3.3. Image specimens. Click the “Image” button in the “Tabulation” box in the “Tabulator” window to activate the “Images” window. All data in fields in this window automatically default to those in the “Tabulator” window, including the name of the last taxon counted. If the taxon is not the one you want to document, choose a different name from the drop down box of the same field.

Fill in values in fields under the four tabs.

“Subject” – Taxon name and dimension measurements.

Add information in the “Length,” “Width/Diameter,” and “Striae Density” fields, making sure that the measurements are expressed in microns. If your ocular scale is not 1:1 you must make the necessary conversions. The boxes “Quality” and “Public?” can be left untouched since this is information that will be added by Academy personnel reviewing the image before it is made available on the Phycology Section's web site. We are currently not using the “Caption” field and it can be left blank. Add notes referring to any characteristic of the taxon being imaged, or any taxonomic problems that you may have had with it during sample analysis, to the “Notes” field.

“Who, where, when” – Person taking image, location, image device, etc.

Enter the location from which you are working and the “Image Device” you are using for capturing the image. In the “People” box fill the fields labeled “Determiner,” “Imager” and “Adder” with the proper information. Most of these fields, except for “Image Device” will be automatically filled in with the same data that were entered in the fields in the “Count Information” screen.

“ANSP Sample” – Sample identification information

Fields are filled in automatically.

Digital images must be taken following the steps and recommendations given in the Taxonomic Guidelines document.

When all information in the “Images” screen is complete, including in the tabbed boxes, press the “Save Record” button located on the top right portion. This will save all data in the NADED database. It will also assign the next available identification number, which will appear in the Image ID field, in the upper left hand corner. Record this number for future reference. At the time the image data are saved, the identification number (e.g., IM000027) that is assigned is automatically recorded in the “DigitalImage” table of the ALGAEIMAGE database in a field called “ImageID.” A second field called “ImageFileName” is filled-in at the same time. It contains the identification number with the extension “.png” added (e.g., IM000027.png), which corresponds to the file format used by ANSP to store image files.

Open the imaging program you are using (e.g., Photoshop v 5.5) and edit the image as desired. Save the image in the “Originals” folder located in G:\Phycdata\DATABASE\Images\images. Name the file the “Image FileName” recorded previously.

- 5.4. **Bench sheets.** Enter data recorded on bench sheets directly into the following fields in the specified ANSP PHYCLGY database tables or by using the “DtmCnt” program. As a quality control measure, data should be entered by someone other than the analyst. The analyst should then review the entered data to verify that they were entered correctly. The “DtmCnt” program is in G:\Phycdata\VBAppInstalls\DtmCnt.
- 5.4.1. Table “Diatom Count Information” has several fields that must be entered (mandatory), some that should be entered if data are available (optional), some that will be added later (verification) and several that should be skipped (not applicable):
 - 5.4.2. Sample identifiers are mandatory: **Sample ID**, **SubSample Replicate ID**, **Slide Replicate**, and **Count Replicate ID**.
 - 5.4.3. **Count Type** is mandatory and is “17” for RTH, DTH and phytoplankton samples, and “33” for QMH samples.
 - 5.4.4. **Taxonomy ID** is mandatory and can be looked up in the “Taxonomy Number” table.
 - 5.4.5. **Frustules? (Or Valves)** is mandatory. It is “No” for RTH, DTH, and phytoplankton samples and “Yes” for QMH samples.
 - 5.4.6. **Worker ID** is mandatory, is the ID of the diatom analyst and can be looked up in the “Worker Name” table.
 - 5.4.7. **Worker Address ID** is mandatory and can be looked up in the “Worker Address” table.
 - 5.4.8. **Date Count Started** is optional.
 - 5.4.9. **Date Count Finished** is mandatory.
 - 5.4.10. **Date Count Verified** is for verification.
 - 5.4.11. **Total Time** is mandatory, and refers to the time necessary for the count.
 - 5.4.12. **Verifier Worker ID** is for verification and refers to the Worker ID of the person who verifies that the entered count data represents the actual data from the count.
 - 5.4.13. **Source Data Form** is mandatory and can be looked up in the “Source Data Form” table.
 - 5.4.14. **Diatom Analysis Form ID** is optional and refers to the code for form used to track the diatom analysis procedure.
 - 5.4.15. **Diatom Count Footnote** is not applicable.
 - 5.4.16. **Number Counted** is mandatory for RTH, DTH, and PP samples and should be near “600.” For QMH samples it is optional, and refers to the number of frustules scanned during the procedure.
 - 5.4.17. **Corresponding H₂O Sample** is not applicable.
 - 5.4.18. **Validated** is for verification.
 - 5.4.19. **Taxa Notes** is mandatory.
 - 5.4.20. **Microscope ID** is mandatory and can be looked up in the “Microscopes” table.
 - 5.4.21. **Lense ID** is mandatory and can be looked up in the “Microscope Lenses” table.

- 5.4.22. **Magnification Changer** is mandatory and refers to the amount of magnification from auxiliary lenses (enter 1 if a magnification changer was not used).
- 5.4.23. **Scan Length** is mandatory and refers to the total length of the scan (in mm) during the analysis.
- 5.5. For each diatom species encountered, create a record in the “Diatom Count” table for RTH, DTH and phytoplankton samples, and in the “Diatom Count Qualitative” table for QMH samples. Add data to the following fields:
- 5.5.1. Sample Identifiers as in section 5.4.2: **Sample ID, Subsample ID, Slide Replicate ID and Count Replicate ID.**
- 5.5.2. **TaxonID** is the NADED number for the observed taxon.
- 5.5.3. **NumberCounted** is the number of valves enumerated for RTH and DTH samples; for QMH samples it is the number of frustules observed in the 1st 100-frustule interval.
- 5.5.4. **NumberCells** is the same as NumberCounted for diatom analyses. This field is not used for QMH samples; leave blank.
- 5.5.5. **TaxaNote** is “Yes” or “No” depending whether there was a taxa note concerning this taxon.

6. QUALITY ASSURANCE/QUALITY CONTROL

- 6.1. Sample and slide quality can affect the outcome of these procedures. Minor deviations that do not affect the area scanned or number of specimens observed should be described on bench sheets or in the Note portion (click the “Note” button) of the “Tabulator” program. Other deviations should be discussed with the Phycology Section Project Manager for inclusion in the project QA/QC notes.
- 6.2. This protocol will be carried out under the general provisions of section 5.4. of ANSP, PCER (2000): “Algal Research and Ecological Synthesis for the USGS National Water Quality Assessment (NAWQA) Program. Draft Quality Assurance Project Plan.” According to this plan, “A total of 10% of the samples collected from each study unit will be analyzed for quality control. There will be two types of QA/QC analyses: a re-count of a diatom slide (taxa harmonization count or THC) and a complete re-processing and re-count of the chosen QA/QC sample (replicate subsample count or RSC). The THCs will be performed on diatom samples only while the RSCs will be performed on both diatom and non-diatom samples.”

Diatom Slide Analysis Form - NAWQA

For use with Protocol P-13-39 and samples collected for the U.S.G.S. National Water Quality Assessment Program

Phycology Section - Patrick Center for Environmental Research - The Academy of Natural Sciences

Project Name: USGS NAWQA Algae CO-OP Year 3	Type of Sample/ Count: RTH / DTH (600 Valves/300 Cells), QMH or Phytoplankton
Project ID: GS708230	Analyst:
Subproject ID: ANSPGS0101PR	ANSP Account Number: 708-2302
Study Unit: Acadian-Pontchartrain (ACAD 2001) USGS NAWQA	

Sample ID	Client Sample ID	Sample Type	Slide Replicate ID	ul dripped	Date Completed	Initials	Site Name
GSN71198	ACAD0301ARE0007B	RTH	a b h l	100	__/__/20__	<input type="text"/>	Bayou Lacassine nr Lake Arthur, LA
GSN71200	ACAD0301AQE0007B	QMH-micr	a b h l	150	__/__/20__	<input type="text"/>	Bayou Lacassine nr Lake Arthur, LA
GSN71205	ACAD0301ADE0021B	DTH	a b h l	100	__/__/20__	<input type="text"/>	MERMENTAU RIVER @ MERMENTAU, LA
GSN71208	ACAD0301ADE0022R	DTH	a b h l	100	__/__/20__	<input type="text"/>	MERMENTAU RIVER @ MERMENTAU, LA
GSN71211	ACAD0301ARE0021B	RTH	a b h l	100	__/__/20__	<input type="text"/>	MERMENTAU RIVER @ MERMENTAU, LA
GSN71213	ACAD0301ARE0022R	RTH	a b h l	25	__/__/20__	<input type="text"/>	MERMENTAU RIVER @ MERMENTAU, LA
GSN71215	ACAD0301AQE0021B	QMH-micr	a b h l	100	__/__/20__	<input type="text"/>	MERMENTAU RIVER @ MERMENTAU, LA
GSN71217	ACAD0401ADE0023B	DTH	a b h l	80	__/__/20__	<input type="text"/>	BAYOU DES CANNES NR EUNICE, LA
GSN71219	ACAD0401ARE0023B	RTH	a b h l	400	__/__/20__	<input type="text"/>	BAYOU DES CANNES NR EUNICE, LA
GSN71221	ACAD0401AQE0023B	QMH-micr	a b h l	400	__/__/20__	<input type="text"/>	BAYOU DES CANNES NR EUNICE, LA
GSN71223	ACAD0401ADE0025B	DTH	a b h l	100	__/__/20__	<input type="text"/>	WHISKEY CHITTO CK NR OBERLIN, LA
GSN71225	ACAD0401ARE0025B	RTH	a b h l	100	__/__/20__	<input type="text"/>	WHISKEY CHITTO CK NR OBERLIN, LA
GSN71227	ACAD0401AQE0025B	QMH-micr	a b h l	100	__/__/20__	<input type="text"/>	WHISKEY CHITTO CK NR OBERLIN, LA
GSN71229	ACAD0401ADE0027B	DTH	a b h l	50	__/__/20__	<input type="text"/>	DAWSON CREEK AT BLUEBONNET BOULEVARD
GSN71231	ACAD0401ARE0027B	RTH	a b h l	100	__/__/20__	<input type="text"/>	DAWSON CREEK AT BLUEBONNET BOULEVARD
GSN71233	ACAD0401AQE0027B	QMH-micr	a b h l	50	__/__/20__	<input type="text"/>	DAWSON CREEK AT BLUEBONNET BOULEVARD

PREPARED SLIDES TRANSMITTED BY: _____ Date: __/__/__	PREPARED SLIDES RECEIVED BY: _____ Date: __/__/__
DATA AND SLIDES TRANSMITTED BY: _____ Date: __/__/__	DATA AND SLIDES RECEIVED BY: _____ Date: __/__/__

Figure 1. Diatom Slide Analysis form - NAWQA.

Protocol P-13-51

Analysis of Soft Algae in USGS NAWQA Program Qualitative Multihabitat (QMH) Samples

Frank Acker

1. PURPOSE

- 1.1. The U.S. Geological Survey's (USGS) National Water-Quality Assessment Program (NAWQA) collects several types of algal samples including "Qualitative Multihabitat" (QMH) samples. The QMH samples represent a composited algal collection from the majority of micro-habitats in a defined sampling zone, reach or station. This protocol describes a procedure for analyzing the soft algal component of QMH samples.
- 1.2. "The purpose of QMH sample analysis is to identify as many taxa present in the sample as possible, to provide an accurate and uniform estimate of algal taxa richness in a stream reach. An underlying assumption is that although all algal taxa present in a sample (or on a slide prepared from a sample) will not be identified, most species will be found during a reasonable search. If that effort is consistent among taxonomists, results from analyses of samples and slides will be comparable among analysts and contract laboratories" (Porter, 1994).
- 1.3. This is a qualitative procedure designed to produce a comprehensive list of algal taxa, exclusive of diatoms, for QMH samples.

2. SCOPE

- 2.1. Algal samples are examined and the algae species encountered are identified to lowest possible taxonomic level and recorded.
- 2.2. This procedure is applicable to the analysis of the soft-algal component of samples collected by the QMH sampling protocol of the USGS NAWQA Program. Refer to Procedure No. P-13-39 for a complete discussion of qualitative diatom analysis.
- 2.3. Personnel responsible for these procedures include the periphyton analysts and those involved in data entry.

3. REFERENCES

- 3.1. Moulton, S.R., II, J.G. Kennen, R.M. Goldstein, J.A. Hambrook. 2002. Revised protocols for sampling algal, invertebrate, and fish communities in the National Water-Quality Assessment program, U.S. Geological Survey Open-File Report 02-150. In Press.
- 3.2. PCER, ANSP. 2002. Analysis of Diatoms in USGS NAWQA Program Quantitative Targeted-Habitat (RTH and DTH) Samples. Protocol No. P-13-39.
- 3.3. Porter, S.D. 1994. Amendment to Guidance, Procedures, and Specifications for Processing NAWQA Algal Samples by Contract Laboratories. Email contract reference of 10/19/1994 from Stephen Porter to Allison Brigham of the USGS, Ann St. Armand of Phycotech, Don Charles and Frank Acker of the Academy of Natural Sciences.

- 3.4. Porter, S.D., T.F. Cuffney, M.E. Gurtz, M.R. Meador. 1993. Methods for Collecting Algal Samples as Part of the National Water Quality Assessment Program. U.S. Geological Survey Open-File Report 93-409, Raleigh, NC [39 pp]
http://water.usgs.gov/nawqa/nawqa_home.html.
- 3.5. United States Geological Survey, National Water-Quality Assessment Program. 1997. Procedures for Processing NAWQA Algal Samples. Draft Manuscript. February 1997.

4. DEFINITIONS

- 4.1. **Macroalgae.** A soft-algae component of the QMH samples that consists of visible colonies or filaments.
- 4.2. **Microalgae.** A soft-algae component of the QMH samples that consists of forms that are not visible without the aid of a microscope.

5. APPARATUS/EQUIPMENT

- 5.1. Compound microscope with 40-45x and 100x oil immersion objectives and a total system magnification of 400-450x and 900-1000x, respectively. In addition, a photography system, either film or digital camera, is needed to document new taxa.
- 5.2. Glass microscope slides and coverslips.
- 5.3. Small, flat dishes or trays (e.g., weighing trays, 2-4 inches in diameter).
- 5.4. Pasteur pipettes.
- 5.5. Dissecting needles.
- 5.6. Forceps, very fine.
- 5.7. Pre-printed bench sheets, "Periphyton Community Composition (USGS NAWQA Qualitative Multihabitats QMH) (Figure 1)."

6. METHODS

- 6.1. The analysis of the soft algal component of QMH samples consists of identifying the predominant filamentous and other colonial forms in the macroalgae sample and identifying all taxa in the microalgae sample until few new forms are encountered.

The results of these analyses will potentially be compared with those from samples collected in other areas of the United States. It is therefore important that the level of effort be similar for all samples so that results will be comparable. With the exception of time spent learning new floras, this analysis should be finished in approximately 2 h, on average, sometimes in 3, and never in more than 4 h. Species rich samples will take longer than samples with few soft-algae taxa. If these time limits are being exceeded consistently, it must be reported to the project managers and noted on the bench sheets as a protocol deviation.

6.2. Macroalgae.

- 6.2.1. Place each sample in a small flat tray or dish. This makes it easier to separate and select the macroalgal forms (filaments and other colonies).
- 6.2.2. Prepare a wet mount from a piece of each visible macroalgal form. Use dissecting needle and forceps to transfer algal material to a microscope slide; place cover slip on top of material.
- 6.2.3. Identify forms to the lowest taxonomic level possible and record on a bench sheet. Record notes to document the visible colony shapes, especially those of colonial diatoms.
- 6.2.4. Document each new taxon by taking a film or digital image. Each analyst must take an image of each taxon the first time they encounter it in NAWQA samples, unless they know that at least one suitable image has been taken by another analyst. Also, take images occasionally of good specimens that help document the range of variability of a taxon. It is helpful to separate and save specimens of whole colonial forms in small, labeled vials for future reference.

6.3. Microalgae.

- 6.3.1. Prepare a wet mount. Try to get as many divergent forms on the slide as possible.
 - 6.3.2. Identify all algal taxa encountered on the slide (and record on a bench sheet) until a period of 5 minutes has elapsed during which no new taxa are found.
 - 6.3.3. Prepare a new wet mount and repeat the process. Examine additional wet mounts until two consecutive mounts are completed on which two or fewer new taxa are encountered. Record the number of wet mounts examined on the data sheet.
 - 6.3.4. Take photographs (color slides) or digital images of each form for the project reference collection, as done for macroalgae (see above).
- 6.4. **Data entry.** Enter data from these procedures (listed on bench sheets) in the following two tables of the PHYCLGY database.
- 6.4.1. Table “Non Diatom Count Information.” There is one record for each analysis. Enter the following fields for each record:
 - 6.4.1.1. **Sample ID, SubSample ID, Replicate ID, Palmer-Maloney Fraction ID and Count Replicate ID** describe the specific sample and fraction used. Note: the **Palmer-Maloney Fraction ID** is “q” for qualitative samples.
 - 6.4.1.2. **Count Type** = “32” for these types of analyses.
 - 6.4.1.3. **Worker ID and Worker Address ID** are codes for the analyst. These are listed on the bench sheets.
 - 6.4.1.4. **Date Count Finished, Bench Sheet ID, Microscope ID and Lens ID** are found on the bench sheet and are mandatory for each analysis.
 - 6.4.1.5. **Number of Fields, Palmer-Maloney Field Volume, Total Time, Analysis Form ID, Number Counted and Corresp H₂O Sample** are not required or not applicable.
 - 6.4.1.6. **Mag Changer** should be entered, if applicable, or if not applicable, =1.

- 6.4.1.7. **Count Notes** is “Y” or “N” depending on whether there is a count note associated with the analysis.
- 6.4.1.8. **Validated, Validated By** and **Date Count Validated** are entered, preferably by the analyst after verification of data entry.
- 6.4.2. Table “Non Diatom Count Qualitative.” There is one record for each taxon observed during the analysis. Enter the following fields for each record:
 - 6.4.2.1. **Entry Order** is automatically incremented as data are entered.
 - 6.4.2.2. **Sample ID, SubSampleID, P-MFractionID** and **Count Replicate ID** describe the sample and fraction used in the analysis.
 - 6.4.2.3. **TaxonID** is the NADED Taxon Code for the taxon being entered for this type of analysis.
 - 6.4.2.4. **TaxaNote** is “Y” or “N” depending on whether there is a taxa note for this particular taxon in this analysis.

PHY 15 REV.GS2.3 (12/98)

Academy of Natural Sciences
Environmental Group
Patrick Center for Environmental Research
Phycology Section

PERIPHYTON COMMUNITY COMPOSITION Bench Sheet
(USGS NAWQA Qualitative Multiple Habitats QMH)

bench sheet #: **ANSP-GS-00-__-PR** project code: **GS708130**

ANS sampleID: GS030 __7-PR1-a	NAWQA sampleID: PUGT __98AQE000 B
# subsamples used: _____	microscope id: REIMER1
analyzed by: _____ / ___ / 2000	worker id: 115 address id: 1

blue-greens (Cyanophyta)			

greens (Chlorophyta)			

Figure 1. Periphyton community composition bench sheet.

PHY 15 REV.GS2.3 (12/98)

ANS sampleID: **GS030__7-PR1-a**

project code: **GS708130**

yellow-greens (Chrysophyta)	

reds (Rhodophyta)	

other periphyton phyla			

notes:

data entry by: ____ __/__/2000	confirmed by: ____ __/__/2000
--------------------------------	-------------------------------

Figure 1 (continued). Periphyton community composition bench sheet.

Protocol P-13-63

Analysis of Soft-Algae and Enumeration of Total Number of Diatoms in USGS NAWQA Program Quantitative Targeted-Habitat (RTH and DTH) Samples

Frank Acker

1. PURPOSE

- 1.1. The U.S. Geological Survey's (USGS) National Water-Quality Assessment Program (NAWQA) collects two kinds of quantitative algae samples analyzed by the Phycology Section of the Patrick Center for Environmental Research, ANSP; RTH (Richest Targeted Habitat) samples and DTH (Depositional Targeted Habitat) samples. This protocol describes a quantitative procedure for analyzing the soft-algal component of samples collected with either the DTH or RTH protocol.
- 1.2. This procedure is quantitative and designed to provide data on algal densities (as cells per cm² of sampling surface) and amount of algal biovolume (μm^3 per cm² of sampling surface) at a sampling site.

2. SCOPE

- 2.1. This protocol describes procedures for identification, enumeration, documentation, and measurement of soft- algae. It also describes procedures for recording data and entering data into computer applications.
- 2.2. This procedure is applicable to the analysis of the soft-algal component of samples collected by the DTH and RTH sampling protocols of the USGS NAWQA program. A similar protocol (P-13-39) describes the procedures for analyzing the diatom component of DTH and RTH samples.
- 2.3. Personnel responsible for these procedures include the soft-algae analysts and those involved in data entry.

3. REFERENCES

- 3.1. Palmer, C.M. and T.E. Maloney. 1954. A new counting slide for nannoplankton. American Society of Limnology and Oceanography Special Publication Number 21. 6 pp.
- 3.2. PCER, ANSP. 2002. Analysis of Diatoms in USGS NAWQA Program Quantitative Targeted-Habitat (RTH and DTH) Samples. Protocol No. P-13-39.
- 3.3. United States Geological Survey, National Water-Quality Assessment Program. 1997. Procedures for Processing NAWQA Algal Samples. Draft Manuscript. February 1997.
- 3.4. Weber, C.I. 1973. Biological Field and Laboratory Methods for Measuring the Quality of Surface Waters and Effluents. EPA-670/4-73-001. National Environmental Research Center, Office of Research & Development, U. S. Environmental Protection Agency. Cincinnati, OH.

4. DEFINITION

- 4.1. **Natural counting unit.** Each natural grouping of algae (i.e., each individual filament, colony, or isolated cell) is defined as a natural counting unit. Diatoms are an exception; each diatom cell is always considered a natural counting unit, even if attached to other cells. The main purpose of using 'natural counting units' is to prevent a colonial or filamentous form from dominating a count. It also facilitates the counting of algal forms which have linked cells that may be hard to distinguish.

5. APPARATUS/EQUIPMENT

- 5.1. Compound microscope with 40-45x objectives for a total system magnification of 400-450x, and mechanical stage.
- 5.2. Palmer-Maloney Counting Cells with ceramic chamber, chamber depth of 0.4 mm and volume of 0.1 ml.
- 5.3. Glass microscope cover slips, rectangular, 22 x 50 mm, #1 thickness.
- 5.4. Pasteur pipettes, 5.25 inch.
- 5.5. Rose Bengal dye, dissolved in 90% acetone.
- 5.6. Mechanical tabulator, 8 to 10 positions.
- 5.7. Pre-printed bench sheets, "Periphyton Community Composition Bench Sheet, USGS NAWQA Quantitative Richness and Depositional Targeted Habitats" (Figure 1) and "Algal Biovolume Measurements" (Figure 2).
- 5.8. "Biovol" program (Visual Basic application installed on analysts computer).

6. METHODS

6.1. Prepare Palmer-Maloney counting cell.

- 6.1.1. Spread a small drop of Rose Bengal solution on the base of the chamber of a clean Palmer-Maloney counting cell and let dry. If it is thick ("cake-like") or uneven, clean and repeat.
- 6.1.2. Place a rectangular cover slip (#1 thickness, 22 x 50 mm) at 45° to the counting cell, covering about 1/3 of the chamber, but not across the center of the cell.
- 6.1.3. Thoroughly mix the Palmer-Maloney fraction and draw it into an elongated Pasteur pipette (5.25 inch; about 1-1.3mm inside diameter). Quickly add the fraction drop-wise into the center of the chamber. When the surface tension starts to draw the cover slip across the chamber, adjust the sides of the cover slip so that the ends of the chamber are covered and the cover slip hangs over both sides of the ceramic portion of the counting cell.
- 6.1.4. Add glycerin to the area where the cover slip hangs over the ceramic portion. This seals the cover slip to the counting cell temporarily. Without excess heat or vibration, the counting cell can be used for a week or more.

- 6.2. **Choose to count random fields or along transects.** Select one of the two options below. Neither one is preferred over the other.
- 6.2.1. **Determine random fields:** Using a compound microscope (40-45x objective, 400-450x total system magnification), identify and enumerate algae in selected, random fields. From each Palmer-Maloney counting cell, between 8 and 50 fields can be enumerated; use a second counting cell, if necessary. Choose a random starting place in the upper left-hand quadrant of the counting cell and approximate the number of fields that must be analyzed (300 natural units need to be counted with a minimum of 8 and maximum of 100 random fields). Develop a pattern that allows for equal probability of landing in any area of the chamber with the exception of the edges and the center. A maximum pattern with 50 fields is made by having a grid of 8 x 8, subtracting 3 or 4 fields in either direction of the center.
- 6.2.2. **Determine transects:** Using a compound microscope (40-45x objective, 400-450x total system magnification) with a calibrated stage, identify and enumerate algae along transects, either horizontally or vertically across the chamber of the Palmer-Maloney cell. Without looking into the microscope, choose a location near the left edge in the upper third of the chamber in the Palmer-Maloney cell (if vertical transects are analyzed, choose a location near the top edge in the left third of the chamber). Make a transect by moving only the horizontal stage control (or vertical control for vertical transects) a measured distance. Develop a pattern for the transects that will avoid the center and edges of the Palmer-Maloney cell chamber. A second Palmer-Maloney cell can be used, if necessary (300 natural units need to be counted with a minimum of 1 complete transect).
- 6.3. **Enumerate 300 natural counting units.** With the exception of time spent learning new floras, this analysis should be finished in approximately 1-2 and no more than 4 hours. If these time limits are being exceeded consistently, inform the Phycology Section Project Manager.
- 6.3.1. Using the pattern developed above (section 6.2.), move the microscope stage to a new position in the pattern. Make all movements of the microscope stage without looking through the objectives.
- 6.3.2. **Identify and enumerate all algal forms in the field of view:** Enumerate algal forms using natural counting units. Natural units are defined as one for each colony, filament, diatom cell (regardless if colonial or filamentous) or unicell. With the exception of diatoms, identify algal forms to the lowest possible taxonomic level. Differentiate diatoms to the lowest practical taxonomic level. This will usually be genus, but use of categories like naviculoid, cymbelloid, centric, nitzschoid is appropriate.
- 6.3.3. Categorize diatoms as either “living” or “dead” at the time of collection, and quantify them separately. If there is any protoplast material in the frustule (usually stained reddish by the Rose Bengal), the diatom is considered to have been living when collected.
- 6.3.4. Count the number of algal cells comprising each multicellular counting unit.
- 6.3.5. Tabulate the data on a bench sheet or mechanical tabulator.

- 6.3.6. Repeat steps 6.3.1, 6.3.2 and 6.3.4 until 300 natural counting units have been enumerated. Count only “living” diatoms as part of the required 300 natural algal units.
 - 6.3.7. Add and record the tallies of each taxon on the bench sheet. Record the number of cells for multicellular counting units in parenthesis beside the tally of natural counting units. Within both the “living” and the “dead” categories of diatoms, sum all valves counted and record as “undifferentiated diatoms” (undifferentiated “living” and undifferentiated “dead”).
 - 6.3.8. Record the number of fields or total length of the transect for the area that was observed.
- 6.4. **Measure cell biovolumes.** For each group of samples, measure the dimensions of the taxa that contribute most to sample biovolume.
- 6.4.1. Determine the taxa that need biovolume measurements by listing all the species in the samples collected in a NAWQA study unit that have accounted for 5% or more of a sample count.
 - 6.4.2. For each taxon requiring biovolume measurements, select a simple geometric figure matching the shape of the taxon as best as possible, and determine the dimensions that must be measured. Record this information on a bench sheet “Algal Biovolume Measurements” (Figure 1), one sheet per taxon.
 - 6.4.3. Measure and record the dimensions of at least five specimens. If these measurements are not in the range of previous measurements, measure additional specimens until 15 specimens have been measured from the study unit. No more than five specimens should be measured from a single sample.
- 6.5. **Data entry.** Enter data recorded on the bench sheets into the following three tables of the PHYCLGY database.
- 6.5.1. Table “Non Diatom Count Information.” There is one record for each analysis. Enter the following fields for each record:
 - 6.5.1.1. **Sample ID, SubSampleID, Replicate ID, Palmer-Maloney Fraction ID and Count Replicate ID** describe the specific sample and fraction used.
 - 6.5.1.2. **Count Type** = “31” for these types of analyses.
 - 6.5.1.3. **Worker ID and Worker Address ID** are codes for the analyst. These are listed on the bench sheets.
 - 6.5.1.4. **Date Count Finished, Bench Sheet ID, Microscope ID, Lens ID, Palmer-Maloney Field Volume and Number Fields** are found on the bench sheet and are mandatory for each analysis.
 - 6.5.1.5. **Total Time, Analysis Form ID, Number Counted and Corresp H₂O Sample** are not required or not applicable.
 - 6.5.1.6. **Mag Changer** should be entered if applicable or if not applicable, = 1.
 - 6.5.1.7. **Count Notes** is “Y” or “N” depending if there is a count note associated with the analysis.

- 6.5.1.8. **Validated, Validated By** and **Date Count Validated** will be entered, usually by the analyst after verification of data entry.
- 6.5.2. Table “Non Diatom Count.” There is one record for each taxon observed during the analysis. The following fields are entered for each record:
- 6.5.2.1. **Entry Order** is automatically incremented as data are entered.
 - 6.5.2.2. **SampleID, SubSampleID, P-MFractionID, CountReplicateID** describe the sample and fraction used in the analysis.
 - 6.5.2.3. **TaxonID** is the NADED Taxon Code for the taxon being entered.
 - 6.5.2.4. The **NumberCounted** field represents the number of natural units enumerated. The **NumberCells** is the total of number of cells for the specimens enumerated. The **NumberCells** is equal to the **NumberCounted** for diatoms and forms that are unicellular. For diatoms, enter only data for “living” undifferentiated diatoms (NADED Taxon Code 249999).
 - 6.5.2.5. The **RowNumber** is not entered for these analyses.
 - 6.5.2.6. **TaxaNote** is “Y” or “N” depending if there is a taxa note for this particular taxon in this analysis.
- 6.5.3. Add cell dimension measurements to the table “Biovolume Measurements” in the NADED database. Start the application “BioVol” (current version is 1.0.4) and enter data from the attached paper form “Algal Biovolume Measurements.” Data are added by “BioVol” directly to the NADED table.

7. QUALITY ASSURANCE AND QUALITY CONTROL

- 7.1. This protocol will be carried out under the general provisions of section 5.4. of ANSP, PCER (2000), “Algal Research and Ecological Synthesis for the USGS National Water Quality Assessment (NAWQA) Program. Draft Quality Assurance Project Plan.” According to this plan, “A total of 10% of the samples collected from each study unit will be analyzed for quality control. There will be two types of QA/QC analyses: a re-count of a diatom slide (taxa harmonization count or THC) and a complete re-processing and re-count of the chosen QA/QC sample (replicate subsample count or RSC). The THCs will be performed on diatom samples only, while the RSCs will be performed on both diatom and non-diatom samples.” Quantitative comparisons among counts are based largely on Jaccard’s Index and Percent Similarity.

PHY 08 REV.GS3.40 (8/99)

Academy of Natural Sciences
 Environmental Group
 Patrick Center for Environmental Research
 Phycology Section

PERIPHYTON COMMUNITY COMPOSITION Bench Sheet
 (USGS NAWQA Quantitative Richest and Depositional Targeted Habitats)

bench sheet #: **ANSP-GS-00-____-PR** project code: **GS708130**

NAWQA study unit: PUGT Puget Sound Basins 1998 microscope #: Reimer1 lens description: CWR-40X magnifier changer position: N.A. analyzed by: _____ / ____ / 2000 worker id: 115 address id: 1			
ANSP Tracking #: GS NAWQA Sample ID: PUGT subsample dilution factor: number of fields:	030_____ -PR1-__ : _____ _____	030_____ -PR1-__ : _____ _____	030_____ -PR1-__ : _____ _____
blue-greens (Cyanophyta)			
greens (Chlorophyta)			

Figure 1. Periphyton community composition bench sheet, USGS NAWQA Quantitative Richness and Depositional Targeted Habitats.

PHY 08 REV.GS3.40 (8/99)

bench sheet #: ANSP-GS-00-____-PR

project code: GS708130

ANSP Tracking #: GS		030 ____ -PR1-__	030 ____ -PR1-__	030 ____ -PR1-__			
yellowgreens (Chrysophyta)							
reds (Rhodophyta)							
other periphyton phyla							
diatoms (Bacillariophyta)		dead	live	dead	live	dead	live
249999	total diatoms						
nocode	centric (<10µm)						
nocode	centric (>10µm)						
nocode	pennate						
nocode	pennate/naviculoid						
nocode	pennate/cymbelloid						
nocode	pennate/gomphonemoid						
nocode	_____						
nocode	_____						
nocode	_____						
nocode	_____						
total # of counting units:		_____	_____	_____	_____	_____	_____
notes: _____							

data entry by: ____ __/__/2000				confirmed by: ____ __/__/2000			

Figure 1 (continued). Periphyton community composition bench sheet, USGS NAWQA Quantitative Richness and Depositional Targeted Habitats.

The Academy of Natural Sciences
 Patrick Center for Environmental Research
 Phycology Section

ALGAL BIOVOLUME MEASUREMENTS

Algal Species Name: _____ Species Code: _____

Formula: $BV \text{ (in } \mu\text{m}^3) =$ _____ Shape Code ()

where:

a= _____ b= _____
 c= _____ d= _____
 e= _____ f= _____
 g= _____ h= _____

Measurements: Values represent the number of ocular micrometer units for microscope/lense noted below.

Sample ID	a	b	c	d	e	f	g	h
Literature*								
GSN -PR1-								
GSN -PR1-								
GSN -PR1-								
GSN -PR1-								
GSN -PR1-								
GSN -PR1-								
GSN -PR1-								
GSN -PR1-								
GSN -PR1-								
GSN -PR1-								
GSN -PR1-								
GSN -PR1-								
GSN -PR1-								
GSN -PR1-								
GSN -PR1-								
GSN -PR1-								
GSN -PR1-								
GSN -PR1-								
GSN -PR1-								
GSN -PR1-								

* Reference: _____

Microscope ID: _____ Lense ID: _____ Ocular Micrometer Conversion: _____ μ /unit

Cells Measured By: _____ / _____ / 200 Worker ID: _____ Address ID: _____

Data Entry By: _____ / _____ / 200 Worker ID: _____ Address ID: _____

Confirmed By: _____ / _____ / 200 Worker ID: _____ Address ID: _____

Figure 2. Algal biovolume measurements form.

Protocol P-13-52

Analysis of USGS NAWQA Program Phytoplankton Samples

Frank Acker

1. PURPOSE

- 1.1. The U.S. Geological Survey's (USGS) National Water-Quality Assessment Program (NAWQA) samples phytoplanktonic algae by collecting whole-water samples (Porter et al. 1993, Moulton et al. 2002). This protocol describes quantitative procedures for analyzing the soft-algal component of phytoplankton and counting the total number of diatoms.
- 1.2. This procedure is quantitative and designed to provide data on algal densities (as cells per ml) and amount of algal biovolume (μm^3 per ml) at a sampling site. These data can be compared with data from other sampling sites in the NAWQA program throughout the United States. A similar protocol (P-13-39) describes the procedures for analyzing the diatom component of phytoplankton samples.

2. SCOPE

- 2.1. This protocol is applicable to the analysis of the soft-algal component of whole-water phytoplankton samples collected by the USGS NAWQA program. It includes procedures for identification (to lowest possible taxon level) and enumeration of algal species, taking measurements of the dimensions of some species for biovolume determinations, and recording of all data.
- 2.2. Personnel responsible for these procedures include sample preparers, phytoplankton analysts and those involved with data entry.
- 2.3. Two methods for identifying and counting phytoplanktonic algae are described: 1) using an inverted microscope and a modified Utermöhl sedimentation technique (Hasle 1978), and 2) using Palmer-Maloney counting cells.

3. REFERENCES

- 3.1. Hasle, G.R. 1978. The inverted-microscope method. Chapter 5.2.1 in *Phytoplankton Manual*. A. Sournia, ed. United Nations Educational, Scientific and Cultural Organization. Paris. 337 pp.
- 3.2. Moulton, S.R., II, J.G. Kennen, R.M. Goldstein, J.A. Hambrook. 2002. Revised protocols for sampling algal, invertebrate, and fish communities in the National Water-Quality Assessment program, U.S. Geological Survey Open-File Report 02-150. In Press.
- 3.3. Palmer, C.M. and T.E. Maloney. 1954. A new counting slide for nannoplankton. *American Society of Limnology and Oceanography Special Publication Number 21*. 6 pp.
- 3.4. PCER, ANSP. 2002. Analysis of Diatoms in USGS NAWQA Program Quantitative Targeted-Habitat (RTH and DTH) Samples. Protocol No. P-13-39.

- 3.5. PCER, ANSP. 2002. Preparation of Algal Samples for Analysis Using Palmer-Maloney Cells. Protocol P-13-50.
- 3.6. PCER, ANSP. 2002. Subsampling Procedures for USGS NAWQA Program Periphyton Samples. Protocol P-13-48.
- 3.7. Porter, S.D., T.F. Cuffney, M.E. Gurtz, M.R. Meador. 1993. Methods for Collecting Algal Samples as Part of the National Water Quality Assessment Program. U.S. Geological Survey Open-File Report 93-409, Raleigh, NC [39 pp]
http://water.usgs.gov/nawqa/nawqa_home.html.
- 3.8. United States Geological Survey, National Water-Quality Assessment Program. 1997. Procedures for Processing NAWQA Algal Samples. Draft Manuscript. February 1997.
- 3.9. Weber, C.I. 1973. Biological Field and Laboratory Methods for Measuring the Quality of Surface Waters and Effluents. EPA-670/4-73-001. National Environmental Research Center, Office of Research & Development, U. S. Environmental Protection Agency. Cincinnati, OH.

4. DEFINITIONS

- 4.1. **Aliquot.** Is defined as a portion of a liquid sample or subsample.
- 4.2. **Fraction.** During algal analysis, an aliquot of the soft-algae subsample is used in a counting chamber (use of Palmer-Maloney and Utermöhl chambers are described here). Prior to analysis, the subsample may be concentrated or diluted forming additional solutions from which an aliquot can be taken. We have adopted the term “fraction” to identify the specific solutions that can be analyzed in counting chambers. We identify the original soft-algae subsample as fraction “a;” subsequent solutions, in their own containers, are identified as “b,” “c,” etc.
- 4.3. **Natural Counting Unit.** Each natural grouping of algae (i.e., each individual filament, colony, or isolated cell) is defined as a natural counting unit. Diatoms are an exception; each diatom cell is always considered a natural counting unit, even if attached to other cells. The main purpose of using 'natural counting units' is to prevent a colonial or filamentous form from dominating a count. It also facilitates the counting of algal forms which have linked cells that may be hard to distinguish.

5. APPARATUS/EQUIPMENT

- 5.1. Compound microscope with 10-15x, 40-50x and 90-100x objectives. Objectives are mounted below the stage for the inverted microscope method.
- 5.2. Settling chambers with 10-ml settling tubes. There are several basic varieties of the Utermöhl sedimentation chambers including: (1) the tubular variety (e.g., HydroBios Tubular Plankton Chamber) consisting of a threaded, fitted base with a round cover slip (#1, 27.5 mm diameter) base plate, and (2) the combined plate chamber variety (e.g., PhycoTech Utermöhl Counting Chamber) consisting of a plexiglass base unit with a round cover slip (#1, 27.5 or 25.1 mm) base plate and thick glass (0.2 mm) cover plate.
- 5.3. Pre-printed laboratory bench sheets including “USGS NAWQA Palmer-Maloney Fraction Preparation Bench Sheet” (See Protocol No. P-13-50), “Phytoplankton Community

Composition Bench Sheet (USGS NAWQA Program)” (Figure 1), and “Algal Biovolume Measurements” form (see Figure 2, Protocol P-13-63).

- 5.4. 20-ml vials with screw top caps.
- 5.5. Mechanical tabulator, 8 to 10 positions.
- 5.6. Palmer-Maloney counting cells with ceramic chamber, chamber depth of 0.4 mm and volume of 0.1 ml.
- 5.7. Glass microscope cover slips, rectangular, 22 x 50mm, #1 thickness.
- 5.8. Pasteur pipettes, 5.25 inch.
- 5.9. Rose Bengal dye, dissolved in 90% acetone.

6. METHODS

- 6.1. **Choose Analysis Method.** Both analysis methods, inverted microscope and Palmer-Maloney counting cell, result in similar counts when used correctly. The inverted scope is better when the original sample volume is limited (i.e., less than 400 ml) because high numbers of cells are needed for the Palmer-Maloney counts. Detritus, a problem with both techniques, is especially troublesome for the inverted microscope method.
- 6.2. **Pre-Concentrate Subsamples.** For both techniques, the original sample should usually be concentrated prior to settling in the Utermöhl chamber or adding to a Palmer-Maloney cell. This initial concentration should be approximately 5-10 times the original whole-water sample, leaving about 20 ml of concentrate for analysis. Samples are concentrated by settling and decanting (settle for at least 2 days) or by centrifugation (1000 g for 20 min). It is important to measure and record the original and final volumes, before and after concentration. In the USGS NAWQA Program, this step is usually performed during the subsampling procedure, using the “NAWQA Sample Volume/SubSample Form” (see Protocol P-13-48). This concentrated sample is then divided into at least two subsamples – one for soft-algae or phytoplankton analysis and one for diatom analysis. Phytoplankton analysis using Palmer-Maloney counting cells involves the preparation of “fractions” prior to analysis (Protocol P-13-50). The aliquots placed in the Utermöhl chamber are considered the “fractions,” and volume, dilution or concentration data are included in the “Palmer-Maloney Fractions” table (accessible via the PHYCLGY database).
- 6.3. **Prepare Palmer-Maloney Counting Cell.**
 - 6.3.1. Spread a small drop of Rose Bengal solution on the base of the chamber of a clean Palmer-Maloney counting cell and let dry.
 - 6.3.2. Place a rectangular cover slip (#1 thickness, 22 x 50 mm) at 45° to the counting cell, covering about 1/3 of the chamber, but not across the center of the cell.
 - 6.3.3. Thoroughly mix the Palmer-Maloney fraction and draw it into an elongated Pasteur pipette (5.25 inch). Quickly add the fraction drop-wise into the center of the chamber. When the surface tension starts to draw the cover slip across the chamber, adjust the sides of the cover slip so that the ends of the chamber are covered and the cover slip hangs over both sides of the ceramic portion of the counting cell. Then add glycerin to the area where the cover slip hangs over the ceramic portion. This seals the cover slip

to the counting cell temporarily; without excess heat or vibration, the counting cell can be used for a week or more.

6.4. Prepare Utermöhl Sedimentation Chamber.

- 6.4.1. Attach a glass cover glass to the bottom of an Utermöhl sedimentation chamber. For tubular varieties of settling chambers, seal a cover glass to the threaded end of the tube and screw the tube into the base assembly. Assemble the plate chamber type of settling chambers by sealing a cover glass on the bottom of the base, locking it into place with the metal ring, and sealing the cylinder on top of the base. Use a light amount of vacuum grease to seal the cover glasses and cylinders. It is critical that the cover glass be clean and grease-free.
 - 6.4.2. Homogenize the concentrated samples by repeatedly inverting the sample bottle. Place a 10-ml aliquot of the sample into the assembled settling chamber.
 - 6.4.3. Let the sample settle for at least 8 hours.
 - 6.4.4. For the plate chamber type of Utermöhl chamber, drain the volumetric cylinder by sliding over the drainage hole. Slide the cover plate over the chamber without allowing air bubbles to form. Analysis should proceed within a few hours of removing the cylinder.
- 6.5. **Choose to count random fields or along transects.** Both methods (inverted microscope and Palmer-Maloney counting cell) involve counting phytoplankton cells in a chamber, by counting either random fields or along transects. Choose one of the following.
- 6.5.1. Determine random fields: Using a high dry microscope objective (40-45x objective, 400-450x total system magnification), identify and enumerate algae in selected, random fields. From each Palmer-Maloney counting cell or Utermöhl chamber, enumerate between 8 and 50 fields; use a second counting cell or sedimentation chamber, if necessary. Choose a random starting place in the upper left-hand quadrant of the counting cell and approximate the number of fields that must be analyzed (300 natural units need to be counted with a minimum of 8 and maximum of 100 random fields). Develop a pattern that allows for equal probability of landing in any area of the cell or chamber with the exception of the edges and the center. A maximum pattern with 50 fields is made by having a grid of 8 x 8, subtracting 3 or 4 fields in either direction of the center.
 - 6.5.2. Determine transects: Using a high dry microscope objective (40-45x objective, 400-450x total system magnification) with a calibrated stage, identify and enumerate algae along transects, either horizontally or vertically across the chamber of the Palmer-Maloney cell or Utermöhl plate chamber. Without looking into the microscope, choose a location near the left edge in the upper third of the chamber (if vertical transects are analyzed, choose a location near the top edge in the left third of the chamber). Make a transect by moving only the horizontal stage control (or vertical control for vertical transects) a measured distance. Develop a pattern for the transects that will avoid the center and edges of the chamber. A second Palmer-Maloney cell or Utermöhl chamber can be used, if necessary (300 natural units need to be counted with a minimum of one complete transect).

6.6. Enumerate 300 natural algal units.

- 6.6.1. Using the pattern developed above (section 6.5.), move the microscope stage to a new position in the pattern. Make all movements of the microscope stage without looking through the objectives.
- 6.6.2. Identify and enumerate all algal forms in the field of view: Enumerate algal forms using natural counting units. Natural counting units are defined as one for each colony, filament, diatom cell (regardless if colonial or filamentous) or unicell. With the exception of diatoms, identify algal forms to the lowest possible taxonomic level. Differentiate diatoms to the lowest practical taxonomic level. This will usually be genus, but use of categories like naviculoid, cymbelloid, centric, nitzschoid is appropriate.
- 6.6.3. Categorize diatoms as either “living” or “dead” at the time of collection, and quantify them separately. If there is any protoplast material in the frustule (usually stained reddish by the Rose Bengal), the diatom is considered to have been living when collected.
- 6.6.4. Count the number of algal cells comprising each multicellular counting unit.
- 6.6.5. Tabulate the data on a bench sheet or mechanical tabulator.
- 6.6.6. Repeat steps 6.6.1., 6.6.2. and 6.6.4. until 300 natural algal units have been enumerated. Count only “living” diatoms as part of the required 300 natural algal units.
- 6.6.7. Add and record the tallies of each taxon on the bench sheet. Record the number of cells for multicellular counting units in parenthesis beside the tally of natural counting units. Group all diatoms into one category – undifferentiated diatoms.
- 6.6.8. Record the number of fields or total length of the transect for the area that was observed.

6.7. **Enumerate larger, rarer taxa.** There is an additional, optional procedure that can be used for samples with low concentrations (less than five natural counting units) of large cells or colonies (maximum dimension greater than 100 μm). Using a low-power objective (10-15x), scan 20 fields or 4 transects. Count the larger, rarer taxa (as defined above). Enumerate as natural units and estimate the number of cells in each. Record the counts of each of the taxa on the bench sheets, noting the scan area (i.e., total area for the 20 microscope fields or 4 transects). Multiply the number of larger, rarer taxa by the ratio of the total area scanned in the regular count to the area scanned in this count. Record that number as the total count for that taxon.

6.8. **Measure cell biovolumes.** For each group of samples, measure the dimensions of the taxa that contribute most to sample biovolume.

- 6.8.1. Determine the taxa that need biovolume measurements by listing all the species in the samples collected in a NAWQA study unit that have accounted for 5% or more of a sample count (i.e., 15 or more natural units of the 300 natural units enumerated).
- 6.8.2. For each taxon requiring biovolume measurements, select a simple geometric figure matching the shape of the taxon as best as possible, and determine the dimensions that must be measured (see the “Shapes” table in the NADEDdat database). Record this

information on an “Algal Biovolume Measurements” bench sheet (See Figure 2, Protocol P-13-63), one per taxon.

- 6.8.3. Measure and record the dimensions of at least five specimens. If these measurements are not in the range of previous measurements, measure additional specimens until 15 specimens have been measured from the study unit. No more than five specimens should be measured from a single sample.
- 6.9. **Enter data.** Enter data recorded on the bench sheets into the following three tables of the PHYCLGY database.
 - 6.9.1. Table “Non Diatom Count Information.” There is one record for each analysis. Enter the following fields for each record:
 - 6.9.1.1. **Sample ID, SubSampleID, Replicate ID, Palmer-Maloney Fraction ID and Count Replicate ID** describe the specific sample and fraction used.
 - 6.9.1.2. **Count Type** = “37” for “Inverted Microscope Proportional (phytoplankton)” and “38” for Palmer-Maloney Proportional (phytoplankton)” counts.
 - 6.9.1.3. **Worker ID and Worker Address ID** are codes for the analyst. These are listed on the bench sheets.
 - 6.9.1.4. **Date Count Finished, Bench Sheet ID, Total Time, Microscope ID and Lens ID**, are found on the bench sheet and are mandatory for each analysis.
 - 6.9.1.5. **Palmer-Maloney Field Volume** is found on the bench sheet and is mandatory for analyses using Palmer-Maloney cells and where algae were enumerated in fields (as opposed to enumerating along transects).
 - 6.9.1.6. **Number Fields** is found on the bench sheet and is mandatory for analyses where algae were enumerated in fields (as opposed to enumerating along transects).
 - 6.9.1.7. **VolumeScanned** is mandatory for analyses using Palmer-Maloney cells. For analyses enumerating fields, it is calculated by multiplying the Number of Fields by the Palmer-Maloney Field Volume. For analyses where phytoplankton were enumerated along transects, the VolumeScanned is calculated by multiplying the scan length in cm (from the bench sheet) by the Microscope Field Diameter in cm (found in the “Microscope Lenses” table of the PHYCLGY database) and then multiplying by 0.04, the depth of a Palmer-Maloney Cell in cm.
 - 6.9.1.8. **Analysis Form ID, Number Counted and Corresp H₂O Sample** are not required or not applicable.
 - 6.9.1.9. **Mag Changer** should be entered if applicable or if not applicable, = 1.
 - 6.9.1.10. **Count Notes** is “Y” or “N” depending on whether there is a count note associated with the analysis.
 - 6.9.1.11. **Validated, Validated By and Date Count Validated** will be entered, probably by the analyst, after verification of data entry.
 - 6.9.1.12. **Phytoplankton Apparatus ID** is found in the “Phytoplankton Apparatus” table of the “PHYCLGY” database and refers to the code for the type of counting (Palmer-Maloney) or settling chamber (HydroBios, PhycoTech, etc.) used (and listed on the bench sheet).

- 6.9.2. Table “Non Diatom Count.” There is one record for each taxon observed during the analysis. The following fields are entered for each record:
- 6.9.2.1. **Entry Order** is automatically incremented as data are entered.
 - 6.9.2.2. **SampleID, SubSampleID, P-MFractionID, CountReplicateID** describe the sample and fraction used in the analysis.
 - 6.9.2.3. **TaxonID** is the NADED Taxon Code for the taxon being entered.
 - 6.9.2.4. **NumberCounted** field represents the number of natural units enumerated. The **NumberCells** is the total of number of cells for the specimens enumerated. The **NumberCells** is equal to the **NumberCounted** for diatoms and forms that are unicellular.
 - 6.9.2.5. **RowNumber** is not entered for these analyses.
 - 6.9.2.6. **TaxaNote** is “Y” or “N” depending if there is a taxa note for this particular taxon in this analysis.
- 6.9.3. The table “Biovolume Measurements” in the PHYCLGY database is updated by running the application “BioVol” (current version is 1.0.4) and entering data from the “Algal Biovolume Measurements” form.

6.10. **Calculation of phytoplankton abundances and biovolumes.** The calculation of phytoplankton abundance depends on the apparatus used during analysis. Biovolume values are determined by multiplying the abundance (cells/ml) by the average biovolume of each cell (μm^3). The average biovolume of each cell is determined by averaging all values for the taxon in the “Biovolume Measurements” table of the PHYCLGY database. If there are no records in the “Biovolume Measurements” table for the taxon, the program performing the calculation will use a predefined constant based on genus (for diatoms) or algae type (for non-diatoms). Equations for abundance calculations are given below. The calculations are performed at the time data are prepared for transmission to the NAWQA BioTDB. The “BioTDB export” application, written in MS Visual Basic, produces a table (“export_NAWQAResults”) on the Phycology Section server (SQL; “Diatom”). This table, which contains the calculated biovolumes, can be accessed by other Phycology Section databases.

- 6.10.1. If the inverted microscope method was used in the analyses, phytoplankton abundance (cells/ml) is calculated as follows:

$$\text{cells /ml} = \frac{\text{countx field dcfx chamber area x subsample dcf}}{\text{microscope fld area x \# of microscope fields x chamber volused}}$$

where:

count = “# cells” in the “Non Diatom Count” table; for diatoms, the number of cells is determined by dividing the “# cells” in the “Diatom Count” table by the total number of diatom cells enumerated and multiplying by the number of “<undifferentiated diatoms>” in the “Non Diatom Count” table.

field dcf = “DC Factor” in the “Sample Volumes/Areas” table.

chamber area = “Chamber Area” in the “Phytoplankton Apparatus” table (in mm²).

subsample dcf = “D/C Factor” in the “Subsample Information” table.

microscope fld area = [“Lense Fld Dia” from the “Microscope Lenses” table (in μm)] divided by 2000, squared and multiplied by Pi (will be in mm²); use the “Lense ID” in the “Non Diatom Count Information” table to get the correct microscope lense that was used.

number of microscope fields = “#Fields” in the “Non Diatom Count Information” table.

chamber volume used = “FractionVolume” from the “Palmer-Maloney Fractions” table.

6.10.2. If Palmer-Maloney counting cells were used in the analyses, phytoplankton abundance (cells/ml) is calculated as follows:

$$\text{cells/ml} = \frac{\text{count} \times \text{field dcf} \times \text{subsample dcf} \times \text{P - M dcf}}{\text{volume scanned}}$$

where:

count, field dcf and subsample dcf are defined as above.

P-M dcf = “D/C Factor” in the Palmer-Maloney Fractions” table.

volume scanned = “VolumeScanned” in the “Non Diatom Count Information” table.

PHY 41 REV.GS3 (2/02)

Academy of Natural Sciences
 Environmental Group
 Patrick Center for Environmental Research
 Phycology Section

**PHYTOPLANKTON COMMUNITY COMPOSITION Bench Sheet
 (USGS NAWQA Program)**

bench sheet #: **ANSP-GS-02-__-PP**

project code: **GS708130**

study unit: 2001 Miami River Basins (MIAM) subproj: ANSP-GS-01-02-PP						
microscope: L1015 lens: Zeiss223165 PP apparatus: 4 count type: 38						
analyzed by: _____ / __/__/2002 worker id: 24 address id: 1						
ANSP sample ID: GSN	82 _____	82 _____	82 _____	82 _____	82 _____	82 _____
subsample-fraction:	PP1 -__	PP1 -__	PP1 -__	PP1 -__	PP1 -__	PP1 -__
# fields:	_____	_____	_____	_____	_____	_____
blue-greens (Cyanophyta)						
dinoflagellates (Pyrrophyta)						
greens (Chlorophyta)						

Figure 1. Phytoplankton community composition bench sheet (USGS NAWQA Program).

PHY 41 REV.GS3 (2/02)

bench sheet #: ANSP-GS-02-____-PP

project code: GS708130

ANSP sample ID: GSN		82 ____	82 ____	82 ____	82 ____	82 ____	82 ____
yellow-greens (Chrysophyta)							
other phytoplankton phyla							
diatoms (Bacillariophyta)							
249999	<undifferentiated live>						
249998	<dead or empty frustules>						
# counting units (cells):		_____	_____	_____	_____	_____	_____
notes: _____							

data entry by: _____/____/2002		confirmed by: _____/____/2002					

Figure 1 (cont'd). Phytoplankton community composition bench sheet (USGS NAWQA Program).

Protocol P-13-53

Preparation of Algal Data Files and Reports for Submission to the USGS NAWQA Program

Candia A. Knowles, Frank Acker, and Kathleen Sprouffske

1. PURPOSE

- 1.1. The U.S. Geological Survey's (USGS) National Water-Quality Assessment Program (NAWQA) collects algae samples from rivers throughout the United States. The Phycology Section of the Patrick Center for Environmental Research is responsible for the identification and enumeration of algae in these samples. For each group of NAWQA algal samples, data files containing results of these analyses are generated and transmitted to the NAWQA Biological Transactional Database (BioTDB). These files form the basis of a data set used to assess regional and national water quality conditions.
- 1.2. The purpose of this protocol is to describe the procedures necessary to perform checks on data quality and completeness. These procedures are followed to ensure that the data files submitted to the NAWQA BioTDB are complete and accurate.

2. SCOPE

- 2.1. This protocol is applicable to the data verification stage of sample analysis. It details the steps necessary to review the data before generating a complete set of data files.
- 2.2. Personnel responsible for the procedures in this protocol include data entry personnel, sample analysts and the Phycology Section Project Manager.

3. REFERENCES

- 3.1. Cotter, P. 2002. Tabulator Installation and User's Guide. Version 3.51. ANSP, PCER.
- 3.2. PCER, ANSP. 2002. Analysis of Diatoms on Microscope Slides Prepared from USGS NAWQA Program Algae Samples. Protocol No. P-13-39.
- 3.3. PCER, ANSP. 2002. Log-In Procedures for USGS NAWQA Program Algal Samples. Protocol No. P-13-47.
- 3.4. PCER, ANSP. 2002. Subsampling Procedures for USGS NAWQA Program Periphyton Samples. Protocol No. P-13-48.
- 3.5. PCER, ANSP. 2002. Preparation of Diatom Slides Using NAPHRAX™ Mounting Medium. Procedure No. P-13-49.
- 3.6. PCER, ANSP. 2002. Analysis of Soft-Algae in USGS NAWQA Program Qualitative Multihabitat (QMH) Samples. Protocol No. P-13-51.
- 3.7. PCER, ANSP. 2002. Archiving Algal Samples, Diatom Slides and Images. Protocol No. P-13-56.

- 3.8. PCER, ANSP. 2002. Analysis of Soft-Algae and Enumeration of Total Number of Diatoms in USGS NAWQA Program Quantitative Targeted Habitat (RTH and DTH) Samples. Protocol No. P-13-63.
- 3.9. United States Geological Survey, National Water Quality Assessment Program. 1997. Procedures for Processing NAWQA Algal Samples. Draft Manuscript. February 1997.

4. METHODS

- 4.1. Prior to file verification and report generation, obtain the three paper folders of documentation for each subproject (defined by NAWQA study unit, the year of collection, and whether the samples are periphyton or phytoplankton): “Sample Tracking and Subsampling”, “Diatom Analyses” and “Soft-Algae Analyses” (see Protocol No. P-13-58). These file folders are started by personnel involved in the sample log-in and preparation phase. They should be circulated with their corresponding samples and subsamples. All pertinent printouts, bench sheets or other documentation should be added to these folders as they are completed (see section 4.4. for details).
- 4.2. **Data Entry Review.** Confirm that the needed data have been created (i.e., analyses are complete) and have been entered into the database. The verification of data cannot start until all data are entered. Listed below are the NAWQAdat database tables containing necessary data, and salient points concerning the verification required:
 - 4.2.1. **Sample Identification.** Should be complete and verified by this point. For each sample, there must be one record with complete data for the fields: “Sample ID”, “Site Location ID”, “Client Sample ID”, “Subproject ID”, “Collection Date/Date1”, NAWQA Sample ID, “result_code”, and “Sample Auto ID”.
 - 4.2.2. **Sample Volumes/Areas.** This table should have been completed during the log-in and subsampling procedures. In some cases, data entered at time of log-in were incomplete or inaccurate. This table is only necessary for quantitative data files and has one record for each sample. Check the following critical fields for completeness and accuracy (these fields cannot be zero or null) and run the queries “Data Entry Check: Field Volumes/Areas” and “Data Entry Check: ANS Sample Volume” in PHYCLGY to make sure all fields required for biovolume calculations are present. When data are complete, print out the results of this query and place them in the “Sample Tracking and Subsampling” folder.
 - 4.2.2.1. Area Sampled. Verify that these values were properly transferred to the Academy’s database.
 - 4.2.2.2. Client DCF Factor (usually = 1). This factor can vary from “1” if there was subsampling and dilution or concentration prior to receipt at the Academy. Since the Academy measures the sample volume, this factor remains “1” unless a portion of the sample was lost prior to receipt at the Academy.
 - 4.2.2.3. **Sample Volume (ANS).**
 - 4.2.2.4. Original Sample Volume. This critical volume relates the amount of sample to the area that was sampled. In most cases there was no subsampling and this value is the same as the “Sample Volume (ANS)” field (the assumption being that a laboratory measurement is more accurate than a field measurement). Where

there is an indication of subsampling with a subsequent dilution of concentration, or when loss of sample is noted, this field or the “Client DCF Factor” field must be adjusted.

- 4.2.3. **Subsample Information.** There will be two records for each sample if only one set of subsamples was made: a diatom (DT1) and a soft-algae (PR1) subsample. There will be more records if more than one subsample was made (e.g., DT2, PR2). For quantitative samples, verify the “Subsample Volume” and “Dilution/Concentration Factor” fields. If subsample volumes do not equal 20 ml, confirm that the volume was adjusted to 20 ml (by dilution or concentration).
- 4.2.4. **Slide Information.** There will be one record for each slide that was made. There should therefore be two records for each sample (unless a 3rd or 4th slide was produced). Verify the “Volume Cleaned Material,” “Dilution/Concentration Factor” and “Volume of Sample on Slide” fields, especially for quantitative samples. Similar to the “Subsample Information” table, check the “Dilution/Concentration Factor” field if the “Volume Cleaned Material” does not equal 20 ml.
- 4.2.5. **Palmer-Maloney Fractions.** For quantitative samples only, there are one to three records for each sample, depending on the number of dilution or concentration steps needed. It is important to verify that there is a record for the Palmer-Maloney fraction that was used in the analysis (in addition verifying that the fraction is from a periphyton subsample [designated with “PR” at the beginning of the subsample code]). Verify the “FractionVolume” and “Dilution/Concentration Factor” fields. It is important to verify that the amount of dilution or concentration relates to the original subsample, and not necessarily to the fraction from which it was diluted.
- 4.2.6. Verification is not necessary for several tables including **Diatom Hierarchy, Non-Diatom Hierarchy, Diatom Taxa** and **Non-Diatom Taxa**. The “...Taxa” tables are child tables of the “...Hierarchy” tables; the “...Count tables are child tables of the “...Taxa” tables. It is good practice to ensure that referential integrity between these tables and related tables is in force when the reports are generated.
- 4.2.7. Verify that **Diatom Count Info** is complete. If diatom analyses were performed using the “Tabulator” program, simply verify that the record for each sample is complete. For diatom analyses where bench sheets were used, verify data entry. Run the “Data Entry Check: Diatom Count Info” query in the PHYCLGY database to produce a table of database records. Print it and check it against data on the bench sheets. Similarly, verify the **Non Diatom Count Information** table by checking that data entry was correct. Run the query “Data Entry Check: Non Diatom Count Information” in the PHYCLGY database to produce a table of database records. Print it and check it against the bench sheets.
- 4.2.8. **Diatom Count.** For analyses using the “Tabulator” program, verify that “Diatom Count” table records have been properly saved with corresponding documentation (count reports signed and dated with all changes and corrections entered and documented). For “Diatom Count” records entered from bench sheets, verify that the data entry has been checked (the database query “Data Entry Check: Diatom Count” in the PHYCLGY database produces a table that is printed out and used to check against the bench sheets).

- 4.2.9. **Diatom Count Qualitative.** Verify qualitative records following a procedure similar to the one for verifying diatom count records (if bench sheets were used, the “Data Entry Check: Diatom Count Qualitative” query in the PHYCLGY database produces the table utilized in data checking).
 - 4.2.10. Verify the **Non Diatom Count** and **Non Diatom Count Qualitative** tables by ensuring that the data entry from bench sheets has been checked (the queries “Data Entry Check: Non Diatom Count” and “Data Entry Check: Non Diatom Qualitative” in the PHYCLGY database produce tables to check against the bench sheets).
 - 4.2.11. Check the **Microscope Lenses** table to ensure that the lens entered in the Diatom Count and Non-Diatom Count tables has the following data: lenses used in the non-diatom analyses (usually 40-50x magnification) should have values for Palmer-Maloney volume (in ml); lenses used for diatom analyses (usually 90-100x) and phytoplankton analyses (usually 15-50x) should have values for field diameter (in μm). Additionally, all lenses must have the correct factor to convert from units to micrometers.
 - 4.2.12. Verify the **Biovolume Measurements** table using the application “frmBiovolumeVerification” (a form in the PHYCLGY database). After the subproject is entered, check both the soft-algae and diatom components to see that the proper number of measurements were made. If fewer than five measurements are recorded for each abundant taxa, require the analyst to measure additional specimens.
- 4.3. **Final Preparatory Work for Data File Generation.** These are the final steps to take before moving on to Procedure No. P-13-55 to use the BioTDB Export application to generate data files.
 - 4.3.1. Download the most recent data from the BioTDB using the NAWQA ASR Download application in the NAWQAApp database (for more information on the NAWQA ASR Download application, see Procedure No. P-13-47). To do this, click the “Download” button on the first tab sheet, entitled “Download”.
 - 4.3.2. Determine if the data used in the biovolume calculation match the most recent data from the BioTDB by running the query “kms_OriginalVolume_0_updates_to_subproject_from_BioTdb.” from the NAWQAApp database. This query compares key values from the BioTDB to those in the ANSP databases. If any values do not match, update them in the NAWQAApp database. Variables compared are Client Subsample Volume, Sample Volume (Client), Preservative Volume, After Decant Volume, and Area Sampled.
 - 4.3.3. Run the next set of queries from the NAWQAApp database. They check the “original volume” data in NADED against the most recent volume data from the BioTDB and update values as necessary.
 - 4.3.3.1. Run the “kms_OriginalVolume_1_FlagAfterDecantVolume” query. This query returns all Sample Volumes/Areas records that have a value for “AfterDecantVol.” All records returned from this query are problematic and must be dealt with on a case-by-case basis to determine the correct values for “original volume” and “dilution/concentration factor.”

- 4.3.3.2. Run the “kms_OriginalVolume_2_NotSubsampled” update query. Updates the Original Volume and Client DC Factor fields in the NADED database for samples that were not subsampled in the field.
- 4.3.3.3. Run the “kms_OriginalVolume_3_Subsampled_NotPhytoplankton” update query. Updates the Original Volume and Client DC Factor fields in the NADED database for non-phytoplankton samples that were subsampled in the field.
- 4.3.3.4. Run the “kms_OriginalVolume_4_Phytoplankton” update query. Updates the Original Volume and Client DC Factor fields in the NADED database for phytoplankton samples that were subsampled in the field.
- 4.4. **Final Archived Files.** As noted earlier, there will be a set of three files (paper folders) used to archive the data from a subproject. The items to be included in each of these files are listed in Protocol No. P-13-58.
- 4.5. Once all data are verified and reported, reference specimens will be archived in the ANSP Diatom Herbarium. See protocol P-13-56 for detailed archiving procedures.

Protocol P-13-55

Electronic Transmission of Data Files to the USGS NAWQA Program

1. PURPOSE

- 1.1. The U.S. Geological Survey's (USGS) National Water-Quality Assessment Program (NAWQA) collects algal samples from rivers throughout the United States. The Phycology Section of the ANSP's Patrick Center for Environmental Research is responsible for the identification and enumeration of algae in these samples. For each group of NAWQA algal samples, electronic data files containing results of these analyses are generated at the ANSP and transmitted to the NAWQA Biological Transactional Database (BioTDB). These files form the basis of a data set used to assess regional and national water quality conditions. This protocol describes the procedures followed to ensure correct and complete transmittal of data generated from the analyses of NAWQA samples.

2. SCOPE

- 2.1. This protocol is applicable to the generation and transmission of completed data sets to the USGS NAWQA program.
- 2.2. This protocol is intended for the use by the Phycology Section Project Manager and other Phycology staff members responsible for communicating with and reporting to the USGS.

3. REFERENCES

- 3.1. Cotter, P. 2002. Tabulator Installation and User's Guide. Version 3.51. ANSP, PCER.
- 3.2. PCER, ANSP. 2002. Preparation of Algal Data Files and Reports for Submission to the USGS NAWQA Program. Protocol No. P-13-53.
- 3.3. Sprouffske, K. and C. Ratnayaka. 2002. BioTDB User Guide. ANSP, PCER.
- 3.4. USGS, NAWQA Program. 2001. Invertebrate and Algae Data Loading Design, 3rd Draft Revised. Reston, VA

4. APPARATUS/EQUIPMENT

- 4.1. A personal computer connected to the ANSP computer network and access to Phycology Section databases and electronic mail.

5. METHODS

- 5.1. The ANSP has developed a Microsoft SQL Server 7.0 database, called NAWQA, to act as a data repository for NAWQA data on their way to the BioTDB. Once data are completed and validated (see Protocol No. P-13-53), data are transferred from the Phycology Section's NADED database into the SQL Server NAWQA database via a Visual Basic 6 application called "BioTDB Export." The several steps involved in data transfer from the ANSP and its subcontractors are summarized in Figure 1.

- 5.2. As of 2002, all data received from subcontractors are in specially prepared databases. Diatom data are in a backend database of the “Tabulator” program; Soft algae data are in the “Subcontractor Soft-Algae Database” (currently designed specifically for data generated by procedures used at Michigan State University). As these data are received, they are saved in the directory G:\Phycdata\Database\ in the “received” folder named for the associated subcontractor.
- 5.3. Use the “BioTDB Export” application to generate output data in the ANSP NAWQA Export database. Follow instructions in the “BioTDB User Guide.” (Sprouffs, K. and C. Ratnayaka. 2002. BioTDB User Guide. ANSP, PCER.)
- 5.4. The SQL Server NAWQA database automatically records when a record was first added to the export queue. It also records the most recent date that any change was made to the record. When files are generated to send to the BioTDB, the records in the table with the results (“export_nawqasamples”) are all stamped with the “transfer date.”
- 5.5. Create the five data files necessary for uploading into the BioTDB, Follow the instructions in the BioTDB Export User Guide. These data files are defined and documented in the Invertebrate and Algae Data Loading Design, 3rd Draft. In brief, the files consist of a list of all samples, results, and taxa that have ever been run through “BioTDB Export” application.
- 5.6. To package the data files for transmittal to the USGS, open the program “WinZip” (typically installed at C:\Program Files\Winzip, although it will be where ever you installed it) and click the “New” button to create a new archive file. Name the archive file as the default filename prefix that was generated for you by the BioTDB Export program and click “OK.” Click the “Add” button, navigate to G:\Phycdata\Projects\NAWQA\NAWQA_Database\NAWQABIOTDB\submitted, highlight the 5 files created during the listing process in section 5.5 (they all begin with the same prefix), and click the “Add” button. Close WinZip by selecting File, Exit.
- 5.7. After ensuring that the files are, in fact, archived using WinZip by re-opening the newly-zipped file, delete the original files from the directory. Email or FTP the archive to the USGS and retain the archive in the G:\Phycdata\PROJECTS\NAWQA\NAWQA_Database\NAWQABIOTDB\ submitted directory.
- 5.8. A history of uploads to the BioTDB is maintained in “G:\Phycdata\PROJECTS\NAWQA\NAWQA_Database\NAWQABIOTDB\submitted\history.txt” by the person submitting the data. When the data are successfully transmitted to the USGS BioTDB, a record is added here.
- 5.9. All data thus prepared are sent to the BioTDB. An e-mail from the NAWQA project manager confirms that the data arrived.

**Algal Data Flow For
NAWQA**

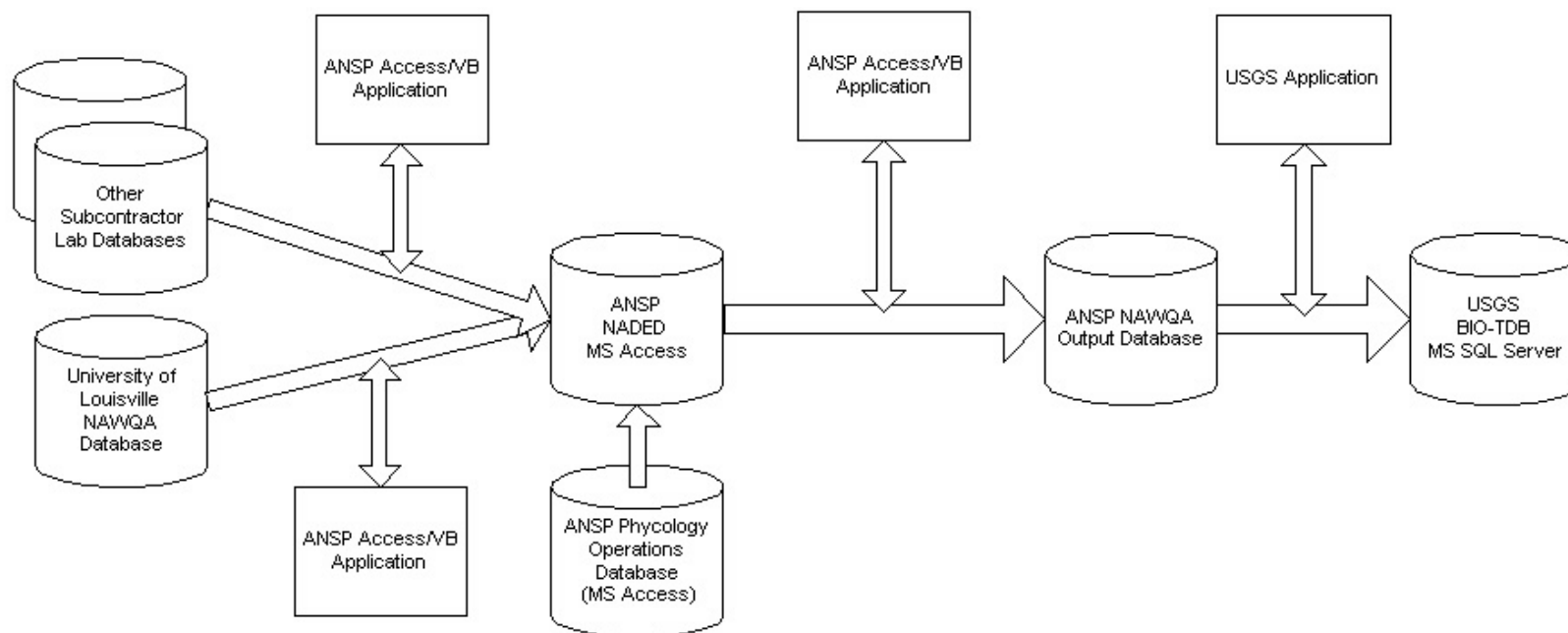

Figure 1. Algal data flow.

Protocol P-13-56

Archiving Algal Samples, Diatom Slides and Images

Joseph Resnick, Su-Ing Yong, Donald Charles

1. PURPOSE

- 1.1. The Phycology Section of the ANSP analyzes algae samples collected throughout the United States. After these analyses are completed, portions of samples and resulting materials, such as slides and images, are archived for future reference.
- 1.2. This protocol outlines the procedures followed to store diatom cleaned material, sample remnants, Palmer-Maloney fractions, diatom slides, electronic images and photographic images. The protocol is to be followed to ensure safe, long-term storage of reference materials, to provide complete and accurate cataloging of information on archived material, and to allow for easy retrieval of all materials.

2. SCOPE

- 2.1. This protocol is applicable to the last stage of sample handling. When all data have been completed, verified and reported, all portions of samples and materials to be maintained are stored.
- 2.2. Personnel responsible for the procedures in this protocol include Phycology Section staff members and Diatom Herbarium staff members.

3. REFERENCES

- 3.1. PCER, ANSP. 2002. Diatom Cleaning by Nitric Acid Digestion with a Microwave Apparatus. Protocol No. P-13-42.
- 3.2. PCER, ANSP. 2002. Preparation of Diatom Slides Using Naphrax Mounting Medium. Protocol No. P-13-49.
- 3.3. PCER, ANSP. 2002. Preparation of Algal Samples for Analysis Using Palmer-Maloney Cells. Protocol No. P-13-50.

4. APPARATUS/EQUIPMENT

- 4.1. Personal computer connected to the ANSP network server and with access to the Phycology Section databases.
- 4.2. Avery® 3x5 white index cards for laser printers.
- 4.3. Horsehide glue paper.
- 4.4. Paper cutter.
- 4.5. Wooden boxes for storing microscope slides (25 slides each).

5. METHODS

5.1. Diatom cleaned materials, sample remnants, and Palmer-Maloney fractions.

- 5.1.1. Appropriately labeled diatom cleaned materials, sample remnants and Palmer-Maloney fractions are sorted by year sampled and locality and then placed in vented cabinets in the Phycology laboratory for long-term storage. All materials are stored indefinitely, except remnants of original samples which will be kept routinely for a period of three years.
- 5.1.2. Unless otherwise specified, all bottles or other containers with sample material should have a paper label with Sample ID, SubSample ID, station (substation/replicate), date, project name, original amount of material and other appropriate data. When samples are archived or sent to other locations, information on the action is documented using the “Transmittals” application in the PIMS form of the PHYCLGY database. This transmittal process records in the database the new location of the material, the names and addresses of persons involved, and the date. It also generates a paper form summarizing the transmittal information that can serve as a chain-of-custody record.

5.2. Diatom slides.

- 5.2.1. Diatom slides prepared for analyses by Phycology Section analysts are appropriately labeled and stored permanently in the ANSP Diatom Herbarium. The ANSP Diatom Herbarium contains slides of sample material collected throughout the world. A locality file card catalog is maintained in the Diatom Herbarium to enable users to find slides with material collected from specific geographic regions.
- 5.2.2. A computer-based form is used to create labels for the slides as well as 3x5 cards for the card catalog. The following step-by-step instructions describe how to create labels and cards for the accession of slides into the Diatom Herbarium. Before starting the process, have available all the necessary information on slides to be accessioned. This might include Subproject ID and Shipping ID. Make use of the following query and reports in the PHYCLGY database to help locate these IDs and other data:
“qry_GetSampleSiteInfoForIndividualSample,”
“rpt_ListofShippingIDsForSubprojects,” “rpt_ListofSlidesBySubproject,” and
“rpt_ListDiatHerbAccessionNumberForSlide.”
 - 5.2.2.1. Open the Phyclgy.mdb database file located in G:\Phycdata\
DATABASE\PHYCLGY.MDB
 - 5.2.2.2. Open the form “DHDB Main Accession Form” (Figure 1). This form steps through the process of adding slides to the Diatom Herbarium.
 - 5.2.2.3. Step 1: Identify Slides to be Transferred, Create Record of Shipment, Create Tables of Data to Add to the DHDB and, Assign Accession Number.
 - 5.2.2.3.1. Click on the “Shipments Form” button (Figure 2); a new form will open. Click on the button on the bottom of the form that creates a new shipment record. This button looks like an arrow pointing right toward an asterisk. This button will clear the form and assign a new shipping ID. It will also fill in the “Date Shipped” field with the current date. If a different date needs to be entered, enter it now.

- 5.2.2.3.2. Pull down the “Item” combo box and select “DHDB Hand-Transfer” from the selection (Figure 3). This action will automatically enter data into all of the fields at the top of the form with the exception of the “Sender” and the “Packer.”
- 5.2.2.3.3. Enter the “Sender” and the “Packer” data in their respective fields using the drop down box. On most occasions these names will be the same. (If the worker name you need is not in the list, stop what you are doing, saving any progress you have made. Minimize the form. Open the form “frmWorkerInfo” and enter the name of the new worker and related information. Then return to the “Shipments Form” and continue.)
- 5.2.2.3.4. Click on the “List Builder” Button to open the “DHDBIDBuilder” Form (Figure 4). The window on the left side of the form is the window that shows the Slides to be selected from; transferring them to the right side window signifies that those specific slides are to be transferred to the Diatom Herbarium.

Click on the button on the top left to select a searching criterion. Either Slide ID, Project ID, or Subproject IDs can be used to search. (Note that whether data are displayed by the Slide Replicate ID, or not, can be controlled by using the combo box on the top right of the selection area. This allows a’s and b’s, for example, to be listed together, or not.)

A dialog box will appear asking the technician to enter the first few characters of what is being searched for. Enter that information and press OK.

A list of slide IDs matching the specified criteria will appear in the left window. Locate and highlight the slides to be transferred and either double click on them individually, select a group and click the Add button (looks like “>”), or single click on them individually and click the Add button.

Note: Be sure to examine the value in the field on the right side of the left window. It will have a value of “0”, “-1” or “100.” If the slides to be transferred have a value of “100,” stop immediately; there is a problem that needs to be addressed. (This problem can be fixed by verifying that the site location information is correct. This error occurs when the application cannot determine what state in the U.S.A. the sample is from. Check for the addition or deletion of leading zeros in the “Site Location ID” field of the “Site Location” table.)

Once IDs of all the slides to be transferred have been moved to the window on the right (and there are no values of what would now be “-100” in the field on the right), click on the OK button and return to the Shipments form.

- 5.2.2.3.5. Note that the identification numbers of the selected slides appear in the box at the bottom of the form. At this point, they have been assigned an appropriate Diatom Herbarium accession number. The following accession numbers have been reserved for the Phycology Section: 100000 through 109999 for samples from states east of the Mississippi River and numbers 110000 through 119999 for samples from states west of the Mississippi River. Note that if the record created contains samples from states both east

and west of the Mississippi River, two separate reports will automatically be created.

5.2.2.3.6. Note the Shipping ID at the top left of the form and proceed to the next step.

5.2.2.3.7. To exit this form and continue, either close the form out with the X on the top right of the form, or click on the Exit button on the bottom right (it looks like an arrow pointing at a door). Exiting this form will create entries in the database located in G:\herb\herbdata\DHDBTransfer.mdb. This database contains all the information herbarium staff will need to enter into the Diatom Herbarium database.

5.2.2.3.8. After closing, a prompt will ask if you want to save the changes you have made. Answer yes.

5.2.2.4. Step 2: Prepare to Create Slide Labels, Index Cards, and Accession Report

5.2.2.4.1. After returning to the DHDB Main Accession form, step two requires selecting the shipment ID in the combo box in the middle of the page. Click on the combo box and find the Shipping ID number noted in section 5.2.2.3.6. **Note:** From this point on, each step made will be logged in a progress table automatically. Take note that after completing each step the appropriate check box will be checked. If a step is not yet completed, or stopped in the middle, be sure to uncheck the appropriate check box before continuing.

5.2.2.5. Step 3: Create Slide Labels

5.2.2.5.1. Click on the button marked "Slide Label Form."

5.2.2.5.2. Select the appropriate slide label format by clicking on the appropriate button (most likely DHDB).

5.2.2.5.3. Look over the slide labels on the computer screen and make sure they are correct.

5.2.2.5.4. Cut a sheet of horsehide glue paper into four 8 ½" x 11" sheets. Prepare each individual sheet for the printer by carefully attaching a non-stick sheet of paper to the glue side of the sheet. To prevent a misfeed into the printer, place a piece of tape across the entire length of the top of the attached sheets.

5.2.2.5.5. Feed each prepared sheet into the printer one at a time, press the print button, or go to "File," "Print" and press "OK."

5.2.2.5.6. Exit from the slide label report page and click "Exit" on the style selection form.

5.2.2.6. Step 4: Create 3x5 Index Cards

5.2.2.6.1. Click on the Button labeled "3x5 Card Form." A window open with some instructions. Read the instructions and click on the "Go to Report" button.

5.2.2.6.2. Be sure to insert the 3x5 card paper into the printer and print the generated 3x5 card documents.

5.2.2.6.3. Close out the 3x5 card report and click exit on the instruction form to return to the DHDB Main Accession Form.

5.2.2.7. Step 5: Create Acquisition Book Report

5.2.2.7.1. Click on the button labeled “Acquisition Book Report.” This will generate a form to be put in the Curator’s Acquisition Book. Print the generated document and close the report to return to the DHDB Main Accession Form.

5.2.2.8. Step 6: Finish

5.2.2.8.1. Make sure that all of the check boxes are checked (with the exception of the “finished” check box) and go back to complete any steps not completed. When all is completed, click on the “Finish!” button and close the form (or begin a new “Shipments Form”).

5.2.2.9. Step 7: Attach Labels to Slides and Submit to the Diatom Herbarium

5.2.2.9.1. Attach the printed labels to the appropriate slide. Click on the “See How” button to be sure that the labels are placed on the correct side of the slides. Note: If the analyst prefers not to view the diagram to perform this task, click on the check box next to it to signify that this task is completed.

5.2.2.9.2. Gather the labeled slides, the 3x5 cards, and the Accession Book Report and submit them to the Diatom Herbarium.

5.3. **Electronic and photographic images.**

5.3.1. Electronic and photographic images are taken during the analyses of both soft algae and diatoms. These images are also stored for future reference. Specific procedures vary with project. Both diatom and soft-algae images can be stored in the ANSP Algae Image Database (<http://diatom.acnatsci.org>). Soft-algae images are often recorded on film and stored as 2" x 2" Kodachrome slides. Many will be added later to the ANSP Algae Image Database.

Microsoft Access

File Edit View Insert Format Records Tools Window Help

DHDB Main Accession Form : Form

Diatom Herbarium Database Accession Form

Follow these steps to correctly transfer slides to Diatom Herbarium

1. Complete Shipments Form

2. Enter Shipment ID#: Currently Editing Shipment ID#: 0

3. Create Slide Labels I have completed this step.

4. Put labels on slides I have completed this step.

5. Print 3 x 5 cards I have completed this step.

6. Print Report (Acquisition Book) I have completed this step.

7. Bring everything to Diatom Herbarium I have completed this step. Done!

JR

Form View

NUM

Figure 1. DHDB Main Accession form.

Microsoft Access

File Edit View Insert Format Records Tools Window Help

Shipments

Shipping ID: 11 Date Shipped: 4/9/98

Item: Slide Digital?: No Physical?: Yes

Delivery Service: Brokers Worldwide

Sender: Acker, Frank

Packer: Acker, Frank

Ship To: USGS/NWQL **New**

Last Name: Kingston First Name: John

Address: 5293 Ward Road, MS 426

City: Arvada State: CO Zip: 80002

You must select New from the buttons on the bottom of this form before entering a new shipment.

Shipped Items: List Builder

SampleID	SubsampleID	SlideReplicateID
GS028003	DT1	a
GS028013	DT1	a
GS028023	DT1	a
GS028033	DT1	a
GS028043	DT1	a
GS028053	DT1	a
GS028063	DT1	a

Print Transmittal Form

Date item(s) were shipped

Figure 2. Shipments form.

Shipping ID
11

Date Shipped
4/9/98

Item
Slide

Digital?
No

Physical?
Yes

Delivery Service
Brokers Worldwide

Sender
Acker, Frank

Packer
Acker, Frank

Ship To
USGS/MWQL **New**

Last Name: Kingston **First Name:** John

Address: 5293 Ward Road, MS 426

City: Arvada **State:** CO **Zip:** 80002

You must select New from the buttons on the bottom of this form before entering a new shipment.

Shipped Items: List Builder

SampleID	SubsampleID	SlideReplicateID
GS028003	DT1	a
GS028013	DT1	a
GS028023	DT1	a
GS028033	DT1	a
GS028043	DT1	a
GS028053	DT1	a
GS028063	DT1	a

Print Transmittal Form

Date item(s) were shipped

Figure 3. Shipping form.

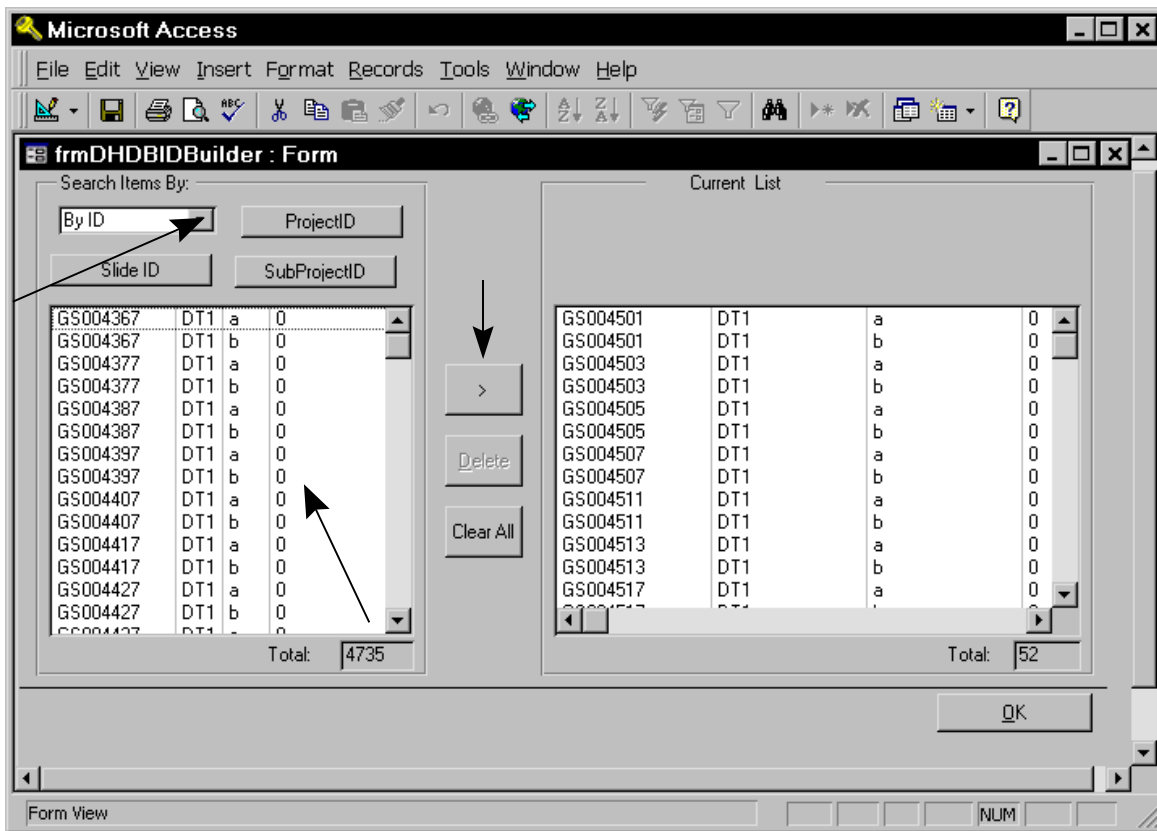

Figure 4. DHDBIDBuilder form.

Protocol P-13-57

Care and Maintenance of Phycology Section Equipment

Lont Marr

1. PURPOSE

1.1. Laboratory equipment is prone to collection of dust, normal wear, and miscellaneous breakdowns. Routine maintenance of equipment and instruments used in and related to the analysis of algal samples is essential to promote accurate and precise results. The following are guidelines and procedures for the maintenance of a variety of equipment used in Phycological Section laboratories.

2. SCOPE

2.1. The following procedures are applicable to similar equipment used in most any scientific laboratory setting.

3. APPARATUS/EQUIPMENT

3.1. Phycology Laboratory.

3.1.1. Compound light microscopes.

3.1.2. Computer equipment.

3.1.3. Fume hoods.

3.1.4. Gas suspension tables.

3.1.5. Slide warmers/hot plates.

3.2. Chemistry Laboratory.

3.2.1. Microwave.

3.2.2. Balances.

4. METHODS

4.1. Compound light microscopes.

4.1.1. Microscopes are very delicate pieces of equipment and should be maintained appropriately. Protect scopes with a well-fitted dust cover when not in use. Shut off scopes and associated light sources when not in use to prolong bulb life and prevent problems associated with overheating.

4.1.2. Keep all lenses and optics free of dust and moisture. Clean using a photographic grade lens paper and an approved lens cleaner. (Products containing alcohol should be used with care to avoid dissolving cement around the optics.) A can of compressed air is useful for removing dust and other particle buildup without having to come in contact with the lenses and is therefore recommended. Periodically clean oil

immersion lenses and oil condensers of oil build-up. Periodically have scopes and associated equipment, such as cameras and imaging equipment, serviced by a professional certified technician.

4.2. Computers, associated peripherals and software.

4.2.1. Maintain all computer equipment to ensure proper use and prolong life. Keep all hardware free of dust and moisture. Clean monitors with an approved cleaning agent and clean keyboards with an aerosol duster such as Dust-Off[®]. Keep software organized in a dust free area and protected from electromagnetic sources. All software purchases and upgrades must be approved by the Computer Services Section so that all licensing requirements can be monitored.

4.3. Fume hoods.

4.3.1. The Laboratory Safety Officer must check fume hoods annually to ensure that they meet national standards for air velocity. Maintain records of these annual inspections. Keep fume hoods free of clutter, volatile chemicals and any objects that could interfere with airflow and/or inhibit the work environment.

4.4. Gas suspension tables.

4.4.1. Gas suspension/anti-vibration tables should receive periodic maintenance. Maintain correct nitrogen pressure through observation of associated pressure gauges, and monitor the volume of gas left in the tank. Replace cylinders as needed. Any unexplained loss in pressure is a major concern - check valves and all connections for leaks and tighten any loose connections. Dust tabletops regularly, and adjust the table level, as needed.

4.5. Slide warmers/hot plates.

4.5.1. This equipment requires very little maintenance. Keep slide warmers and hot plates free of materials by regularly wiping them, and cleaning with appropriate solvents. ALWAYS turn off slide warmers and hot plates when not in use and NEVER leave them unattended. As with all electric appliances, inspect the cords periodically for nicks or frays. If the cord or plug are damaged in any way, take the appliance out of service.

4.6. Microwave.

4.6.1. Periodically clean the CEM microwave used in the diatom cleaning process inside and out, removing any build-up of dust and other particles. The microwave is located in the chemistry lab, and regular maintenance is performed by the PCER Chemistry Section on an as-needed basis.

4.7. Balances.

4.7.1. Keep balances in a draft-free environment and clear of debris. Have balances calibrated on a regular basis by a certified technician.

Protocol P-13-59

Reporting of Non-Conformance Issues and Corrective Action

Frank Acker and Candia Knowles

1. PURPOSE

- 1.1. In order to provide credible data, algal analysis procedures must follow the appropriate Phycology Section protocols, including those describing QA/QC measures. All steps in the process are to be reviewed and documented by the appropriate personnel. If there are any deviations from the approved methods, they must be documented to avoid producing questionable or invalid data. This procedure outlines steps to take in the event that a non-conformance is detected at any level of the analytical process.

2. SCOPE

- 2.1. This protocol is applicable to any stage of the analytical process: sample receipt and log-in, sample preparation, analysis, review and/or reporting.
- 2.2. This protocol is applicable to personnel performing any of the tasks mentioned in 2.1.

3. DEFINITIONS

- 3.1. **Deviation.** A deviation is defined as an action that is in variance with the written, formalized protocol.
- 3.2. **Non-conformance.** Non-conformance is defined as a deviation that was not corrected or was undocumented during the normal course of the analysis.

4. METHODS

- 4.1. **Non-conformance action.** The initial responsibility to monitor the quality of data lies with the analyst, who documents that all protocols are followed (with deviations noted) and results are therefore acceptable. A non-conformance is found if an assessment reveals that any steps in the protocols are not followed or protocol deviations were not documented. A non-conformance must be reported to the Phycology Section Project Manager. If possible, potential causes and corrective action should be identified.
- 4.2. **Corrective action reporting.** When a non-conformance occurs, a corrective action report (CAR) is generated (see Figure 1 for the CAR form). A CAR number is assigned and logged in the CAR log (see Figure 2 for an example of the CAR log). Specific details pertaining to the non-conformance are included on the form as well as the chosen corrective action (if applicable). The report must be approved by the Phycology Section Project Manager (or designee) and filed along with the project files for the affected samples. This information is also included in the QC report associated with the affected samples.

The Academy of Natural Sciences		
Phycology Section Corrective Action Report		
		CAR No. _____
		Date _____
Project _____		
Initiator _____		
Condition Description		
Recommended Action		
Action Taken	Action performed by _____	Date _____
Verified by _____	Date _____	
Approved _____	Date _____	
Title _____		

Figure 1. Corrective Action Report form.

Protocol P-13-62

Chemical Hygiene Practices Used in Phycology Section Laboratories

Benjamin Russell

1. PURPOSE

- 1.1. This procedure provides guidelines for the proper handling and disposal of laboratory chemicals as well as the appropriate safety guidelines to be followed in the Phycology Section laboratories.

2. SCOPE

- 2.1. This procedure applies to all personnel performing laboratory tasks for the Phycology Section.

3. REFERENCES

- 3.1. Material Safety Data Sheets (MSDS).
- 3.2. PCER, ANSP. 1995. Liquid Waste Handling and Disposal Procedures for Chemistry Laboratory. Protocol No. P-16-40.
- 3.3. PCER, ANSP. 2002. Preparation of Diatom Slides Using Naphrax™ Mounting Medium. Protocol No. P-13-49.

4. APPARATUS/EQUIPMENT

4.1. Hazardous Chemicals

- 4.1.1. Formalin
- 4.1.2. Nitric Acid
- 4.1.3. Hydrogen Peroxide
- 4.1.4. Solvents
- 4.1.5. Naphrax™

4.2. Personal Protective Equipment

- 4.2.1. Safety Glasses
- 4.2.2. Gloves
- 4.2.3. Lab Coat

4.3. Equipment

- 4.3.1. Fume Hoods

5. METHODS

5.1. Formalin.

- 5.1.1. Formalin is the chief preservative used in algae samples analyzed in the Phycology Section. Formalin (formaldehyde) is a known carcinogen and direct dermal contact and inhalation of fumes are to be avoided. Perform all work processing samples preserved with formalin in a fume hood while wearing the appropriate personal protective equipment (PPE): safety glasses, gloves and a lab coat, at a minimum.
- 5.1.2. Formalin is a combustible material and therefore should be kept from heat and flame.
- 5.1.3. When disposing formalin, dilute the waste and pour down the sink drain while flushing with copious amounts of water.

5.2. Nitric acid.

- 5.2.1. Nitric acid is used in the sub-sample digestion process to remove organic materials from within and around the diatom frustules. Nitric acid is highly reactive. Therefore perform all work in a fume hood and wear safety glasses, gloves and a lab coat when handling this corrosive, oxidizing material.
- 5.2.2. Keep nitric acid from heat and flames.
- 5.2.3. When disposing nitric acid wastes, pour a very dilute stream down the sink drain while running water to flush the pipes of any residual waste.

5.3. Hydrogen peroxide.

- 5.3.1. Hydrogen peroxide is used to digest organic materials. Hydrogen peroxide may be used to supplement digestions performed with nitric acid or it may be used as the primary digesting agent. Hydrogen peroxide is a corrosive material and should be used under a fume hood while wearing safety glasses, gloves and a lab coat.
- 5.3.2. Hydrogen peroxide wastes may be diluted and poured down the sink drain while flushing with water.

5.4. Solvents.

- 5.4.1. Toluene and ethanol are used during the diatom slide mounting process. Handle solvents with care and wear safety glasses, gloves and a lab coat when handling these materials. Noxious vapors are generated when the toluene is vaporized by heat during the slide mounting process. Therefore, this portion of the preparation must be performed in a fume hood.
- 5.4.2. Toluene waste is in the form of vapors and is removed via the fume hood.

5.5. Naphrax™.

- 5.5.1. Naphrax™ is the mounting medium used in the preparation of diatom slides. When working with this material, wear safety glasses, gloves and a lab coat. See Protocol No. P-13-49 “Preparation of Diatom Slides Using Naphrax™ Mounting Medium” for more information.