

NOT MEASUREMENT  
SENSITIVE

DOE-STD-1066-97  
March 1997

# DOE STANDARD

# FIRE PROTECTION DESIGN CRITERIA



**U.S. Department of Energy**  
**Washington, D.C. 20585**

**AREA GDRQ**

**DISTRIBUTION STATEMENT. Approved for public release; distribution is unlimited.**

This document has been reproduced directly from the best available copy.

Available to the Department of Energy (DOE), DOE contractors and the public from the DOE Office of Worker Health and Safety, Bellemead Building, 19901 Germantown Road, Germantown, MD 20874-1290; (301) 903-4794.

## TABLE OF CONTENTS

Section	Page
1. SCOPE .....	1
2. PURPOSE .....	1
3. REFERENCED CRITERIA .....	2
4. DEFINITIONS .....	4
5. GENERAL FIRE PROTECTION DESIGN CRITERIA .....	9
5.1 Protection to Limit Loss Potential .....	9
5.2 Structural Considerations .....	9
5.3 Fire Suppression Systems .....	10
6. WATER SUPPLY AND DISTRIBUTION SYSTEMS .....	12
6.1 Demand .....	12
6.2 System Arrangement .....	12
7. AUTOMATIC SPRINKLER SYSTEMS .....	14
8. FIRE ALARM SYSTEMS .....	15
9. STRUCTURAL FIRE PROTECTION CRITERIA .....	16
9.1 General .....	16
9.2 Fire Barriers .....	16
9.3 Flame Spread .....	16
9.4 Roofing Systems .....	17
9.5 Penetrations .....	17
9.6 Carpets and Rugs .....	17
10. LIFE SAFETY .....	18
11. ELECTRICAL EQUIPMENT .....	20
12. GENERAL PROCESS HAZARD FIRE PROTECTION .....	21
13. SPECIAL HAZARDS .....	22
13.1 General .....	22
13.2 Plutonium Processing and Handling Facilities .....	22
13.3 Plutonium Storage Facilities .....	22
13.4 Enriched Uranium Storage Facilities .....	22
13.5 Uranium Processing and Handling Facilities .....	22
13.6 Reprocessing Facilities .....	23
13.7 Uranium Conversion and Recovery Facilities .....	23

14. NUCLEAR FILTER PLENUM FIRE PROTECTION .....	24
14.1 Purpose and Scope .....	24
14.2 Filter Plenum Construction .....	24
14.3 Location of Final Filter Plenum Ventilation System Equipment .....	25
14.4 Protection of Openings in Fire Rated Construction .....	26
14.5 Materials and Special Hazards Inside Plenums .....	27
14.6 Prefilters, Duct Entrance Filters, and Fire Screens .....	28
14.7 Detection Systems .....	29
14.8 Deluge Spray Suppression Systems .....	31
14.9 Special System Guidelines .....	33
14.10 Fire Hazard Analysis .....	34
15. GLOVEBOX FIRE PROTECTION .....	35
15.1 Scope .....	35
15.2 Glovebox Construction .....	35
15.3 Automatic Fire Suppression/Inerting Systems .....	38
15.4 Manual Fire Suppression .....	42
15.5 Fire Detection Systems .....	43
15.6 Glovebox Ventilation .....	44

**Appendices**

Appendix A. Nuclear Filtration and Air Cleaning Systems .....	A-1
Appendix B. Operating Temperatures for HEPA Filters .....	B-1
Appendix C. General Criteria Summary Table and Plan Diagram .....	C-1
Appendix D. Discussion on Evaluating Duct Openings When Penetrating 2-Hour .....	D-1
Appendix E. Example Glovebox Fire Detection Systems .....	E-1
Appendix F. Fire Extinguisher Quick Disconnect Coupling .....	F-1
Appendix G. Dry Powder Extinguishing Agent Holder .....	G-1
Appendix H. Limited Water Sprinkler Design .....	H-1
Appendix I. Glovebox Window Material Comparison .....	I-1
Appendix J. Glovebox Overpressure Protection Valves .....	J-1
Appendix K. Glovebox Fire Protection Survey .....	K-1
Appendix L. References .....	L-1
Appendix M. Concluding Material .....	M-1

## FORWARD

This Department of Energy (DOE) Standard is approved for use by all DOE elements and their contractors.

DOE Standards are part of the DOE Directives System and are issued to provide supplemental guidance regarding the Department's expectations for fulfilling its requirements as contained in rules, Orders, and notices. The Standards provide acceptable methods for implementing these requirements.

Beneficial comments (recommendations, additions, deletions) and any pertinent data that may improve this document should be sent to the name and address below by letter or by using the self-addressed Document Improvement Proposal (DOE F 1300.3) appearing at the end of this document.

Dennis Kubicki  
Office of Environment, Safety and Health  
Office of Occupational Health and Safety Policy  
Bellemead Building  
U.S. Department of Energy  
19901 Germantown Road  
Germantown, MD 20874-1290

## 1. SCOPE

The provisions of this Standard apply as guidance to the following:

- a. All departmental elements as delineated in the scope of DOE 420.1, "Facility Safety," and DOE 440.1, "Worker Protection Management for DOE and Contractor Employees," and their respective Contractor Requirements Documents (CRD).
- b. The purchase and lease, as well as the design and construction, of all DOE facilities erected, modified, or renovated after the effective date of this Standard.

**Nothing in this Standard is intended to limit the application of other fire protection methods when unique situations or hazards warrant an alternate approach. The alternate approach should provide a comparable level of safety to that achieved by conformance with this Standard.** Such alternate approaches should be approved by the Authority Having Jurisdiction (AHJ), after consultation with a qualified fire protection engineer.

## 2. PURPOSE

The development of this Standard reflects the fact that national consensus standards and other design criteria do not comprehensively or, in some cases, adequately address fire protection issues at DOE facilities.

This Standard provides supplemental fire protection guidance applicable to the design and construction of DOE facilities and site features (such as water distribution systems) that are also provided for fire protection. **It is intended to be used in conjunction with the applicable building code, National Fire Protection Association (NFPA) Codes and Standards, and any other applicable DOE construction criteria.**

This Standard replaces certain mandatory fire protection requirements that were formerly in DOE 5480.7A, "Fire Protection," and DOE 6430.1A, "General Design Criteria." It also contains the fire protection guidelines from two (now canceled) draft standards: "Glove Box Fire Protection" and "Filter Plenum Fire Protection." (Note: This Standard does not supersede the requirements of DOE 5480.7A and DOE 6430.1A where these DOE Orders are currently applicable under existing contracts.)

This Standard, along with the criteria delineated in Section 3, constitutes the basic criteria for satisfying DOE fire and life safety objectives for the design and construction or renovation of DOE facilities.

### **3. REFERENCED CRITERIA**

DOE facilities and their associated fire protection features are subject to the applicable sections of the current editions of the criteria listed below.

#### **Federal Criteria**

- o 29 CFR Part 1910, "Occupational Safety & Health Standards"
- o 29 CFR Part 1926, "Safety & Health Regulations for Construction"
- o Americans with Disabilities Act Accessibility Guidelines (ADAAG)
- o Other statutory requirements, not listed above, that delineate criteria of a more limited extent relating to facility fire safety.

#### **DOE Requirements**

- o DOE O 420.1, "Facility Safety"
- o DOE O 420.1, "Contractor Requirements Document"
- o DOE O 440.1, "Worker Protection Management for Federal and Contractor Employees"
- o DOE O 440.1, "Contractor Requirements Document"
- o DOE M 440.1-1, "DOE Explosives Safety Manual"
- o DOE 5480.7A, "Fire Protection" (Applicable under some existing contracts)
- o DOE 6430.1A, "General Design Criteria" (Applicable under some existing contracts)
- o DOE/EV/06194, "DOE Explosives Safety Manual" (Applicable under some existing contracts)
- o Other DOE Orders, not listed above, that delineate criteria of a more limited extent that relate to facility fire safety.

#### **DOE Guidelines**

- o DOE-HDBK-1062-96, "DOE Fire Protection Handbook"
- o DOE-HDBK-1081-94, "Primer on Spontaneous Heating and Pyrophoricity"
- o DOE-STD-1020-94, "Natural Phenomenon Hazards Design and Evaluation Criteria"
- o DOE-STD-1088-95, "Fire Protection for Relocatable Structures"
- o G-420.1/B-0, "Implementation Guide for use with DOE Orders 420.1 and 440.1 Fire Safety Program"

## **Other Criteria**

- o National Fire Protection Association Codes and Standards
- o State and Local Building and Fire Codes applicable in the area (Uniform Building Code if no local building code exists)
- o National Fire Protection Association Handbooks, Guides and Recommended Practices
- o Factory Mutual Loss Prevention Data Sheets
- o Society of Fire Protection Engineers Handbook
- o USNRC Guidelines on Fire Protection for Fuel Cycle Facilities, (Vol.) 57 Federal Register, (Pages) 35607-13, August 10, 1992

## **Referenced Standards**

American Society for Testing and Materials (ASTM)

ASTM E-84 Standard Test Method for Surface Burning Characteristics of Building Materials

ASTM E-119 Standard Method of Fire Tests of Building Construction and Materials

ASTM E-136 Tests of Behavior of Materials in a Vertical Tube Furnace at 750 Degrees Celsius

ASTM E-176 Standard Terminology of Fire Standards

ASTM E-814 Fire Tests of Through Penetration Stops

ASTM C-852 Standard Design Criteria for Plutonium Gloveboxes

American Society of Mechanical Engineers (ASME)

ASME AG-1-1994 Code on Nuclear Air and Gas Treatment (revision of ASME AG-1-1991)

Institute of Electronic and Electrical Engineers (IEEE)

IEEE-399 Recommended Practice for Industrial and Commercial Power System Analysis

IEEE-493 Recommended Practice for the Design of Reliable Industrial and Commercial Power Systems

Underwriter's Laboratories, Inc. (UL) Standards

UL-555 Standard for Fire Dampers and Ceiling Dampers

UL-586 High Efficiency Particulate Air-Filter Units

UL-900 Test Performance of Air Filter Units



#### 4. DEFINITIONS

Acceptable - When applied to fire safety, "acceptable" is a level of protection which the Authority Having Jurisdiction, after consultation with the cognizant DOE fire protection engineer(s), considers sufficient to achieve the fire and life safety objectives defined in DOE Orders. In some instances, it is a level of protection necessary to meet a code or standard. In other instances, it is a level of protection that deviates (plus or minus) from a code or standard as necessary and yet adequately protects against the inherent fire hazards.

Adsorber Systems - A system for removing gases or vapors from air by means of preferential physical condensation and retention of molecules on a solid surface. Adsorbers used in nuclear applications are often impregnated with chemicals to increase their activity for organic radioactive iodine compounds.

Authority Having Jurisdiction (AHJ) - The decision making authority in matters concerning fire protection. The DOE Head of Field Organization or designee is the final AHJ unless otherwise directed by the Cognizant Secretarial Officer.

Combustible Liquid - A liquid having a closed cup flash point at or above 100 °F (38 °C).

Combustible Material - Any material that will ignite and burn. Any material that does not comply with the definition of "noncombustible" as contained in this Standard is considered combustible. The term combustible is not related to any specific ignition temperature or flame spread rating.

Criticality Incident - The release of energy as a result of accidentally producing a self-sustaining or divergent neutron chain reaction.

Deep Bed Fiberglass Filter - A ventilation filter made of deep beds of compacted fiberglass contained in stainless steel boxes having opaque sides and perforated screens at the top and bottom for the removal of particulate matter.

Deep Bed Sand Filter - Particulate filter constructed of deep beds of rock, gravel, and sand, formed in layers graded with about two to one variation in granule size from layer to layer.

Demister - A device used to protect the final filter in an air cleaning system from entrained moisture in the air.

(Note: Demisters for fire protection purposes are usually perforated bent plate type mist eliminators fabricated by taking two flat perforated metal sheets spot-welded together and uniformly spacing them a few thousandths of an inch apart, with perforations in adjacent sheets offset so that air entering the holes in the first sheet impinges on the second sheet and must make two 90 degree turns before it can escape. The two perforated metal sheets are then bent or pleated with saw tooth angles of 45 degrees to increase the surface area per square foot of frontal area. Moisture from a perforated plate type mist demister is removed by impingement of droplets on the water film flowing down between the sheets and on the face of the first sheet. Perforated bent plate-type demisters must be installed with the pleats in the vertical position so that water can flow off them easily.)

Duct Entrance Filter - A filter unit installed at the exhaust duct entrance(s) to prevent entrance and accumulation of combustible or flammable dusts and/or residues inside the exhaust ducts. (Note: This is a concern of particular interest to the nuclear industry because radioactive substances tend to deposit or "plate out" on ducts. Dust accumulation inside duct surfaces can create fires that are

serious because they occur in the ventilation system leading directly to the final exhaust plenum filters.)

Exhaust Plenum Final Filter - The final filter unit in a set of filters arranged in a series for ventilation and effluent discharge in an air cleaning system.

Fire Area - A location bounded by construction having a minimum fire resistance rating of 2 hours with openings protected by appropriately fire-rated doors, windows, dampers, or penetration seals. The boundaries of exterior fire areas (yard areas) or other locations that represent unique conditions should be as determined by the cognizant fire protection engineer (contractor or DOE).

Fire Loss - The dollar cost of restoring damaged property to its pre-fire condition. When determining loss, the estimated damage to the facility and contents should include replacement cost, less salvage value. Fire loss should exclude the costs for:

- o property scheduled for demolition; and
- o decommissioned property not carried on books as a value.

Fire loss should include the cost of:

- o decontamination and cleanup;
- o the loss of production or program continuity;
- o the indirect costs of fire extinguishment (such as damaged fire department equipment); and
- o the effects on related areas.

Fire Protection Engineer - A graduate of an accredited engineering curriculum and having completed not less than 4 years of engineering practice, 3 of which shall have been in responsible charge of diverse fire protection engineering work. If not such a graduate, a qualified engineer shall either: demonstrate a knowledge of the principles of engineering and have completed not less than 6 years engineering practice, 3 of which shall have been in responsible charge of diverse fire protection engineering projects; be a registered professional engineer in fire protection; or meet the requirements for a Grade 11 or higher Fire Protection Engineer as defined by the Office of Personnel Management.

Fire Protection System - Any system designed to detect and contain or extinguish a fire, as well as limit the extent of fire damage and enhance life safety.

Fire Resistance Rating - The time that a particular construction will withstand a standard fire exposure in hours as determined by ASTM E-119.

Fire Screen - An item of equipment installed ahead of all HEPA filter banks intended to reduce flame propagation and glowing/burning ember products from reaching final high efficiency particulate air (HEPA) filters.

Flammable Liquid - A liquid having a closed cup flash point below 100 °F (38 °C) and having a vapor pressure not exceeding 40 psia (2068 mm Hg) at 100 °F (38 °C).

Flame Spread Rating - Flame spread rating is a numerical classification determined by the test method in ASTM E-84, which indexes the relative burning behavior of a material by quantifying the spread of flame of a test specimen. The surface burning characteristic of a material is not a measure of resistance to fire exposure.

Glovebox - A sealed enclosure with viewing windows designed to separate the space in the enclosure from its surroundings and in which all items in the enclosure are handled using gloves that are sealed to the enclosure walls.

Heat Resistant - A material having the quality or capability of withstanding heat for a specified period at a maximum given temperature without decomposing or losing its integrity.

High Efficiency Metal Fiber (HEMF) Filter - A reusable metal filter composed of fine sintered stainless steel fibers together with a stainless steel wire and metal support housing and pleated to enhance strength, surface area, and particle holding capacity.

High Efficiency Particulate Air (HEPA) Filter - A disposable extended pleated medium dry type filter with a rigid housing having a minimum particle removal efficiency of at least 99.97 percent (maximum penetration of 0.03%) for particles of 0.3 microns or greater (by light scattering mean droplet diameter) when tested with monodisperse dioctylphthalate (DOP) smoke and maximum pressure drop of 1.0 inch (2.54 centimeters) of water when clean and operated at its rated airflow capacity. HEPA filters consist of a material that is a thin mat of fine intertwined glass fibers that are folded back and forth around separators, and then enclosed by a plywood or metal frame. HEPA filters are easily damaged by very high temperatures and aerosols, and can fail when subjected to moisture and/or structural loading.

From ASME AG-1-1994: A throwaway, extended-media dry-type filter with a rigid casing enclosing the full depth of the pleats. The filter shall exhibit a minimum efficiency of 99.7% when tested with an aerosol of essentially monodispersed 0.3 micron test aerosol particles.

Hydrophoric Materials - Materials that react violently with water or water vapor (such as lithium and lithium hydride).

Limited Supply Suppression System - A system installed in accordance with the applicable NFPA Standards and having a limited quantity of suppression agent. These systems typically include carbon dioxide, dry chemical, other gaseous agents, or water.

Listed/Approved - Equipment or materials that have been tested, passed, and are included in a current list published by a nationally recognized testing laboratory which is concerned with product evaluation and is acceptable to the AHJ. The laboratory maintains periodic inspection of production of listed equipment or materials. Such lists state either that the equipment or material meets appropriate standards or has been tested and found suitable for use in a specified manner. This definition applies to products which are Underwriter's Laboratories (UL) listed or Factory Mutual (FM) approved.

Maximum Possible Fire Loss (MPFL) - The value of property, excluding land value, within a fire area, unless a fire hazards analysis demonstrates a lesser (or greater) loss potential. This assumes the failure of both automatic fire suppression systems and manual fire fighting efforts.

Noncombustible - A material that in the form in which it is used and under the conditions anticipated will not ignite, burn, support combustion, or release flammable vapors when subjected to fire or heat, as defined by fire protection industry standards on the basis of large scale fire tests performed by a nationally recognized independent fire test authority.

Occupancy - The purpose for which a building, or portion thereof, is used or intended to be used. For DOE facilities, the occupancy classification for purposes of determining construction, protection

and area limitations should be as determined under the provisions of the applicable local building code or the Uniform Building Code unless otherwise specified by the AHJ.

Pre-filter - A filter that is located upstream from another filter. Prefilters, or roughing filters, remove and/or reduce the percentage of large particles that would reduce the life of the next-in-line or final filters.

(Note: Although final HEPA filters are excellent collectors of very small particles, they are likely to plug when subjected to high loads of dust and large smoke particles generated in a fire. Prefilters help remove the large particles and dust that would accumulate on the HEPA filters. Prefilters can generally be located at any point in the exhaust ventilation system before the final HEPA filters and sometimes are located in the final filter plenum enclosure.)

Pyrophoric Material - A material with an autoignition temperature in air at or below 130 degrees F (54.4 degrees C) and 50% relative humidity.

Redundant Fire Protection System - A fire protection system that is designed and installed to function in the event of the failure of a primary fire protection system. Where redundant fire protection systems are specified, any two of the following are considered satisfactory:

- o Automatic suppression systems, such as fire sprinklers, foam, gaseous, explosion suppression, or other specialized extinguishing systems plus appropriate alarms. An adequate supply, storage, and distribution system is an essential element.
- o Automatic fire detection, occupant warning, manual fire alarm, and fire alarm reporting systems (considered together) combined with a sufficiently-staffed, properly-equipped and adequately-trained fire department or brigade that is able and committed to respond in a timely and effective manner.
- o Fire barrier systems or combinations of physical separation and barriers for outdoor locations.
- o Other systems, such as alternate process control systems, as approved by the AHJ.

Redundant fire protection systems may include dual water supplies to sprinkler systems, dual piping risers, or valving systems such that adequate redundancy in water supply to the sprinkler heads is provided to cover maintenance or emergency outages of either of the water supply systems or may include multiple types of automatic fire suppression systems (e.g., water sprinklers and a gaseous fire suppression system).

Portable fire extinguishers, interior fire hose systems, or interior fire detection and alarm systems do not meet the definition of a redundant fire protection system.

Smoke Developed Rating - Smoke developed rating is a numerical classification determined by ASTM E-84, which indexes the smoke generation rate of a given material to those of two standard materials ( inorganic reinforced cement board and select grade red oak).

Special Facilities - As used in this standard, the term "special facilities" includes the following:

- o Emergency Preparedness Facilities
- o Explosives Facilities

- o Fusion Facilities
- o Hazardous Waste Incinerator Facilities
- o Irradiated Fissile Material Storage Facilities
- o Laboratory Facilities (Including Hot Laboratories)
- o Nonreactor Nuclear Facilities
- o Plutonium Processing and Handling Facilities
- o Plutonium Storage Facilities
- o Radioactive Liquid Waste Facilities
- o Radioactive Solid Waste Facilities
- o Reprocessing Facilities
- o RCRA Storage Facilities
- o Secure Conference Rooms
- o Telecommunications, Alarm, Central Data Processing Centers and Radio Repeater Stations
- o Tritium Facilities
- o Unirradiated Enriched Uranium Storage Facilities
- o Uranium Conversion and Recovery Facilities
- o Uranium Enrichment Facilities
- o Uranium Processing and Handling Facilities
- o Vaults and Vault-type Rooms for Storage of Classified Matter
- o Other Facilities as Defined by the AHJ

## 5. GENERAL CRITERIA

### 5.1 Protection to Limit Loss Potential

- 5.1.1 When the Maximum Possible Fire Loss (MPFL) exceeds \$50 million, a redundant fire protection system should be provided that, despite the failure of the primary fire protection system, will limit the loss to acceptable levels as determined by the Authority Having Jurisdiction (AHJ).
- 5.1.2 When the MPFL exceeds \$150 million, a redundant fire protection system **and** a 3-hour fire barrier should be provided to limit the MPFL to acceptable levels as determined by the AHJ.
- 5.1.3 Where a potential fire would represent an unacceptable risk to the health and safety of the public, workers, the environment, DOE programs or DOE property (as determined by a fire hazard analysis) fire protection should be provided for special structures, commensurate with the risk. (Refer also to DOE-STD-1088-95, "Fire Protection for Relocatable Structures.")
- 5.1.4 All DOE sites and facilities should have access to a fully-staffed, completely-equipped and adequately-trained fire department that is capable and committed to respond to fires and related emergencies on site in a timely and effective manner. If, on the basis of a "Needs Assessment" or "Operational Basis Document" (Refer to DOE O 420.1, "Facility Safety."), it is determined that such a capability does not exist and that DOE is, consequently, subject to a higher loss potential, additional fire protection features should be provided to compensate for the deficiencies determined. The fire department capability to reduce loss due to a fire should be considered in terms of the following factors:
  - o location of fire station(s) with respect to the facility to be protected;
  - o staffing of stations (e.g., continuously or "on-call volunteer");
  - o ability to perform initial fire attack as outlined in NFPA 1410;
  - o method(s) of fire department notification or alarm reception; and
  - o familiarity of station staff with the DOE facility, and training in preparation for effective response to an alarm at the DOE facility.

### 5.2 Structural Considerations

- 5.2.1 New permanent structures in excess of 5,000 square feet floor area should be of noncombustible or fire resistive construction if no local building code is enforced.
- 5.2.2 Interior fire barriers should be provided to isolate hazardous occupancies, to minimize the potential for fire spread (including products of combustion) and loss potential, and to help assure the orderly evacuation of facility occupants, consistent with the conclusions of the Fire Hazards Analysis (FHA) that is performed in conjunction with the design process. Openings in such barriers

should be protected with appropriately fire-rated doors, windows, dampers or penetration seals. (Refer to the applicable building code.)

- 5.2.3 To protect the integrity of the physical barriers associated with process confinement systems, fire protection features should include the following:
- o A fire-extinguishing system to rapidly remove heat produced by fire to prevent or minimize the pressurization of a process confinement and to rapidly extinguish a fire to minimize the loading of ventilation system filters with combustion products.
  - o The introduction of the extinguishing agent in a way that does not result in over-pressurization of the confinement barriers.

### 5.3 Fire Suppression Systems

5.3.1 All facilities of significance, including facilities where a fire could cause unacceptable off-site consequences to health and safety, should be protected by an automatic fire suppression system (usually a Wet Pipe Sprinkler System). A decision to install another type of fire suppression system should be based on engineering analysis performed by a fire protection engineer. DOE has, historically, considered an facility with an MPFL in excess of \$1 million as being significant from a property protection standpoint.

5.3.2 In some circumstances, the need for automatic fire suppression systems should be considered, despite the absence of explicit requirements, such as when the MPFL is below \$1 million or other limits imposed by DOE. Some examples of situations where automatic fire suppression systems may be warranted are :

- o facilities that contain critical or long procurement time construction items;
- o a temporary-use trailer used as a control center for a vital one-time activity;
- o a facility with high public visibility or sensitivity (as defined by the AHJ);
- o electric power transformers with combustible contents that, if damaged, could result in an extended shut-down of the facilities they serve;
- o facilities in which a fire could result in the accidental release of significant quantities of toxic or hazardous materials or emissions (based on engineering analysis);
- o facilities that can be protected by extending automatic fire suppression systems from an adjacent protected facility or area at a low incremental cost;
- o facilities in which a fire could damage more important adjacent facilities;
- o facilities used to store hard to replace or irreplaceable records;
- o facilities that may warrant automatic fire suppression systems in the future; and

- o facilities where required for protection of human life.
- 5.3.3 Where required by the Safety Analysis Report (SAR), the design of fire protection systems to withstand seismic events should be in accordance the criteria developed by the National Fire Protection Association, except as required by other DOE criteria, such as in Section 7. of this standard.
- 5.3.4 Fire protection systems, or portions of them, that must function to control effects of a Design Basis Accident (DBA) event (as determined by safety analysis accident scenarios) should be designed to be functional for all conditions included in the accident scenario. This should include both the event initial cause and its consequences.
- 5.3.5 When the use of water sprinkler coverage is precluded because of nuclear criticality or other incompatibility reasons, nonaqueous extinguishing systems (e.g., inert gas, carbon dioxide, Halon alternatives, etc.) should be used.
- 5.3.6 Standpipes should be installed in all structures having three levels or more above or below grade. Standpipe systems should be provided in other structures, such as those with extensive and complex interior layouts, where deemed necessary by the DOE Fire Protection AHJ. Standpipes should be designed and installed as Class 1 systems per NFPA 14.



## 6. WATER SUPPLY AND DISTRIBUTION SYSTEM CRITERIA

### 6.1 Demand

- 6.1.1 Domestic water distribution systems that also serve fire protection requirements should be designed to satisfy the calculated Fire Hydrant Demand (see Paragraph 6.1.2) and the peak domestic demand. Where no other requirements are applicable, the peak domestic demand should be based on 2.5 times the calculated average daily demand plus any special demands, such as industrial or processes that cannot be reduced during a fire. The distribution system should be capable of meeting this combined demand at a minimum residual pressure of 20 psi at ground elevation (or higher elevation if special conditions apply) for a period of not less than 2 hours. Municipal supplies having the same capability are acceptable.
- 6.1.2 Fire Hydrant Demand - Where reliance is placed on fire department response, either for protection of unsprinklered buildings or where the fire department will serve as redundant (backup) protection, the water supply available from hydrants should be capable of providing the flow rates established in the Uniform Fire Code based on the most severe facility fire risk on site. These values may be reduced by a maximum of 50% when the facility is provided with automatic sprinkler protection throughout, in accordance with the applicable NFPA Standards.
- 6.1.3 Within a building or facility, domestic water should be supplied by a separate service line and not be a combined fire protection and potable water service or a combined process water and potable water system. Where combined fire and domestic-process water systems are used, distribution piping should be routed and provided with valves such that the domestic and process systems can be isolated without shutting off the fire system supply.

### 6.2 System Arrangement

- 6.2.1 Facilities having a Maximum Possible Fire Loss (MPFL) in excess of \$100 million and significant nuclear facilities (Category 1 Hazard) should be provided with an additional, independent source of fire protection water.
- 6.2.2 Whenever feasible, all water distribution systems should be of the looped grid type providing two-way flow with sectional valving arranged to provide alternate water flow paths to any point in the system. In addition, sectional control valves should be provided to limit the number of hydrants and individual sprinkler systems made inoperative during a single line break to a total of five. Dead end runs utilized as a single supply to fire hydrants should not exceed 300 feet.
- 6.2.3 Listed and/or approved control valves should be installed at maximum intervals of not more than 5,000 feet on long supply lines and at maximum intervals of not more than 1200 feet on main distribution loops, feeders and all primary branches connected to these lines. Such control valves should also be installed at selected points throughout the distribution system to provide system control over each service area. At intersections of distribution mains, one less control valve than the total number of intersecting mains may be provided. As an aid in determining the minimum number of sectional control valves, the critical nature of the

building/facility should be considered as well as the number of fire and domestic systems affected in a potential line failure.

- 6.2.4 Sprinkler system water supply lead-ins should not run under buildings except for the minimum distance possible. Sprinkler system risers and alarm valves should be located as close as practical to a building entry point. Where a riser would otherwise be located in a potentially contaminated area, consideration should be given to locating the riser exterior to the building in a heated enclosure.
- 6.2.5 Hydrants should be provided so that hose runs from hydrants to all exterior portions of a protected building are no more than 300 feet. Hydrants should not be closer to than 40 feet to buildings.

## 7. AUTOMATIC SPRINKLER SYSTEM CRITERIA

- 7.1 NFPA Standard 13 should be used to determine the occupancy classification for any facility. For facilities where there is a potential for a change in occupancy, light hazard occupancy sprinkler system design criteria should not be used.
- 7.2 Hydraulically designed sprinkler systems should be designed for a supply pressure of at least 10% but not less than 10 psi below the supply curve. (Refer to NFPA Standard 13.)
- 7.3 Seismic Criteria
  - 7.3.1 In addition to the seismic requirements delineated in NFPA 13, the following criteria should apply in the design of sprinkler systems that are designated "safety class" per other DOE requirements because they must remain functional during or after an earthquake to mitigate significant nuclear or chemical hazards. These requirements (or shielding) may also be applicable to sprinkler systems whose failure or spurious activation during an earthquake could prevent proper functioning of safety class systems.
  - 7.3.2 The system piping should be supported to resist lateral, longitudinal and vertical seismic loads.
  - 7.3.3 In the design of sway bracing, the criteria of Section 4-6.4.3.5.2 (or current equivalent) of NFPA 13 (1994) should be revised as follows. Horizontal force should be determined by the equation  $F(p) = K \times W(p)$ . A value of K consistent with the criteria in DOE-STD-1020-94 should be determined by an engineer qualified in seismic analysis. Values for K less than 0.5 should not be used unless specifically justified. Exception 1 or 2 following Section 4-6.4.3.5.2 should be applied. If Exception 1 is applied, use "K" instead of "half." If Exception 2 is applied, divide "K" by 0.5 to determine the multiplier for Table 4-6.4.3.5.2 (or current equivalent).
  - 7.3.4 Hangers and braces should be designed to resist any net upward vertical seismic load in excess of the weight of the water filled pipe. An engineer qualified in seismic analysis should determine an appropriate upward vertical loading factor consistent with DOE-STD-1020-94.

## 8. FIRE ALARM SYSTEMS

### 8.1 General Features

Fire alarm systems should comply with NFPA 72 and have the following basic features:

- o Transmission of signals to the responding DOE facility fire department alarm center and other constantly attended locations in accordance with NFPA 72.
- o Local alarms for the building or zone in alarm.
- o Visual alarms for the hearing impaired, where there are high noise levels, or where there are special process requirements as determined by the DOE Fire Protection AHJ.
- o The fire alarm control panel located near the main entrance or a protected location as determined by the AHJ. For buildings with multiple alarm zones, a zone alarm panel or a graphic zone alarm panel at the main entrance to the facility.
- o Supervisory devices for all critical functions except those (such as sprinkler system control valves) that are locked or sealed. (Refer to NFPA Standard 13.)

### 8.2 Alarm Actuating Devices

8.2.1 Alarms that respond to flow of water should be provided within a facility for occupant notification wherever a sprinkler system is installed.

8.2.2 A manual fire notification method, such as telephone, alarm, radio, or manual fire alarm boxes, should be provided at all facilities.

### 8.3 Alarm System Extensions

Extensions to existing fire alarm systems and all new systems in existing buildings or facilities should be compatible with existing fire alarm equipment at the location, including keys/locks, similarity of alarm signals and equipment as well as user operated devices, training requirements, and maintenance procedures.

## 9. STRUCTURAL FIRE PROTECTION CRITERIA

### 9.1 General

Any materials with unusual fire characteristics, such as urethane foams, and any materials that develop significant quantities of toxic or harmful products of combustion (as delineated in Material Safety Data Sheets and other sources of product information), should not be used as interior finishes or other interior applications without the approval of the AHJ. The use of foam plastics in construction should be prohibited unless it fully complies with Factory Mutual (FM) Data Sheet 1-57.

### 9.2 Fire Barriers

9.2.1 Wall, floor and ceiling, and roof and ceiling assemblies should be tested and rated for their fire resistance by Underwriter's Laboratories (UL) or similar nationally recognized testing laboratories, or should be listed for their fire resistance as approved by FM or similar organizations.

9.2.2 Fire Resistance - The development of an FHA and SAR should include consideration of conditions that may exist during normal operations and special situations (e.g., during periods of decontamination, renovation, modification, repair, and maintenance). Where required by the FHA or SAR, the structural shell surrounding critical areas and their supporting members should remain standing and continue to act as a confinement structure during anticipated fire conditions including failure of any fire suppression system not designed as a safety class item. Fire resistance of this shell should be attained by an integral part of the structure (concrete slabs, walls, beams, and columns) and not by composite assembly (membrane fireproofing). In no event should the fire resistance rating be less than 2 hours under conditions of failure of any fire suppression system not designed as a safety class item. (Refer to NFPA Standard 221 and FM Data Sheet 1-22.)

9.2.3 Special facilities should be designed and constructed using building components of fire-resistant and noncombustible material, particularly in locations vital to the functioning of confinement systems. Combustible materials should not be used in the construction of process system confinement barriers.

### 9.3 Flame Spread

9.3.1 Exposed interior wall or ceilings (including ceilings formed by the underside of roofs), and any factory-installed facing material, should have a UL-listed/FM-approved flame spread rating of 25 or less and a smoke developed rating of 50 or less, per ASTM E-84.

9.3.2 Ductwork constructed of Fiberglass Reinforced Plastics (FRP) should be listed or approved for use without interior sprinklers, or should be provided with automatic sprinklers per the applicable FM Data Sheets.

### 9.4 Roofing Systems

9.4.1 Membrane roof systems should be constructed in accordance with the FM Loss Prevention Data Sheets.

9.4.2 Built-up bituminous membrane roofing on metal decks should comply with FM Class I.

## 9.5 Penetrations

9.5.1 Fire Barrier Penetration Seals - Fire barrier penetration seals should comply with NFPA 101, Chapter 6. Penetration seal materials and assemblies should be tested for their fire resistance and listed by UL or similar nationally recognized testing laboratories, or should be approved by FM. Where fire-rated assemblies (walls, floor-ceilings, roof-ceilings) are either partially or fully penetrated by pipes, ducts, conduits, raceways or other such building elements, fire barrier penetration material should be placed in and around the penetrations to maintain the fire resistance rating of the assembly.

9.5.2 Where fire barriers are penetrated by the confinement system's ventilation ducting, fire dampers should be appropriately used to maintain the barrier integrity. However, the closure of such dampers should not compromise the functions of the confinement system where the loss of confinement might pose a greater threat than the spread of fire. In such cases, alternative fire protection means (e.g., duct wrapping, duct enclosure or rerouting) should be used as a substitute for fire barrier closure. Sprinkler systems, such as those designed as a "water curtain," should not be considered a fire barrier substitute.

## 9.6 Carpets and Rugs

9.6.1 Carpets and rugs should be tested in accordance with NFPA 253 (ASTM E-648) when applying the floor finish requirements of the Life Safety Code (NFPA 101) to DOE facilities.

9.6.2 Carpets and rugs used in storage or industrial occupancies (no criteria in NFPA 101) should have a critical radiant flux not less than the following:

- o 0.45 watts per square centimeter in areas unprotected by an automatic fire suppression system; and
- o 0.22 watts per square centimeter in areas protected by an automatic fire suppression system.

## 10. LIFE SAFETY CRITERIA

- 10.1 Life safety provisions should be provided for all facilities in accordance with NFPA Standard 101, "Life Safety Code" (LSC). The methods outlined in NFPA 101A, "Alternate Approaches to Life Safety," may be applied with judgment to all facilities to obtain an equivalent level of life safety where strict compliance with the LSC is not cost-effective. Compliance with the LSC is considered by DOE to satisfy the exit requirements of the applicable building code and 29 CFR 1910.
- 10.2 Any security, radiological control or other physical restrictions to prevent access to or egress from an area should not prevent emergency egress in the event of a fire or related condition. Where conflicting criteria exist, the most effective compromise should be implemented consistent with the objectives of DOE O 420.1, as determined by the AHJ.
- 10.3 In addition to life and fire safety, the design of interior corridors should reflect the following:
  - o personnel traffic flow patterns;
  - o movement of equipment (including initial equipment installations, facility operations and future replacement or removal); and
  - o ultimate decontamination and decommissioning of the facility including equipment required during decontamination.
- 10.4 In those areas where an accidental breach of a primary confinement system could expose personnel to radioactive material, a distance of 75 feet, as measured by the method in NFPA 101, should be the maximum travel distance to ensure that personnel can exit through the next confinement.
- 10.5 Doors that serve as exits from security areas should comply with NFPA 101 and DOE security requirements. (Refer to the egress criteria for Correctional Occupancies for additional guidance.) When security-related hardware is installed on a fire door, the modifications should not adversely affect the fire rating of the door. Such modifications should be in accordance with door manufacturers' guidelines.
- 10.6 Hazardous Areas
  - 10.6.1 When exemptions are granted to specific DOE fire protection standards for reasons unique to DOE facilities, as in the case of some containment structures, fire protection features should be provided so as to assure the life safety of facility occupants as required by the AHJ.
  - 10.6.2 Hazardous areas, such as radioactive spaces or spaces with inert atmospheres, should have sufficient detection, alarms and interlocks to assure that access by emergency personnel will not endanger such personnel or result in a public hazard.

10.6.3 Exit requirements for toxic and explosive environments should be as determined by the AHJ. In addition, for explosives environments, exits should reflect the criteria contained in the DOE Explosives Safety Manual (DOE M 440.1-1).



## 11. ELECTRICAL EQUIPMENT CRITERIA

- 11.1 In addition to the applicable requirements of the National Electrical Code, NFPA Standard 70, transformer installations should comply with FM Data Sheet 5-4/14-8.
- 11.2 Where there is no "listed" equipment or materials of the type, special one-of-a-kind equipment can be accepted if the AHJ can verify that all components meet high quality control standards. Installation methods should be in accordance with the manufacturer's instructions, NFPA 70, and other applicable requirements.
- 11.3 Where multi-tiered cable trays are installed in configurations that represent a significant fire hazard (as determined by the FHA), they should be provided with fire protection/suppression as determined by the AHJ.
- 11.4 Where required by the SAR, critical facilities should be served by dedicated, redundant electric circuits. The two services should be separated by 4-hour fire-rated construction and should be served from separate sources. In lieu of providing two separate services, a single service supplied from a loop-type transmission or distribution system having sectionalizing features may be provided when the reliability of the single service proves adequate when considered in conformance with IEEE 399 and IEEE 493. Locations where fire can damage both normal and emergency power should be protected by redundant fire protection systems.

## 12. PROTECTION CRITERIA FOR GENERAL PROCESS HAZARDS

- 12.1 Compressed gas cylinders that represent a significant fire hazard (as determined by the FHA) should be isolated outside of facilities or housed in a special hazardous materials storage room, exhausted gas cabinets, or similar types of containment.
- 12.2 When a process uses or produces combustible gases or vapors, the design should include features such as inert gas purging, premixing the gas to a nonflammable mixture with inert gas, or increasing the air flow within process confinement barriers to provide the dilution required to maintain the concentration of gases or vapors below the lower limit for flammability.
- 12.3 Lightning protection systems should comply with NFPA 780. Such systems should be considered for buildings containing facilities for the use, processing, and storage of radioactive, explosive and similarly hazardous materials; for buildings over 50 feet in height; and for buildings containing valuable equipment. A risk assessment using the guide in Appendix I of NFPA 780 should be made of these buildings to determine the risk of loss due to lightning.
- 12.4 Process furnaces should be provided with a system for automatically shutting off the gas and purging with inert gas in the event of power failure, loss of coolant water, loss of exhaust ventilation, overtemperature, or detection of hydrogen in the vicinity of the furnace. (See FM Data Sheets for additional guidance.)

## 13. PROTECTION CRITERIA FOR SPECIAL HAZARDS

### 13.1 General

Hazards unique to DOE and not addressed by mandatory codes and standards should be protected by isolation, segregation or use of special control systems such as: inert gas, explosion suppression, etc., as determined by the FHA and the AHJ. In addition, devices for limiting or controlling the effects of a fire (relief valves, filters, blast walls, emergency shutdown systems, scuppers, etc.) should be provided.

### 13.2 Plutonium Processing and Handling Facilities (PPHF)

Only hazardous gases or liquids that are necessary for a process should be used in PPHFs. No natural gas for heating purposes should be used unless the heating occurs in a separate building that is clearly isolated from the primary facility. Other flammable, explosive, corrosive, or toxic gases or liquids that are necessary to the process should be handled under special control and isolated to avoid releases or reactions that might cause injury to workers, the public, or the environment. Those flammable gases that are necessary for a process should be provided by a hard-piped system with the gas supply located outside of the facility in cylinders rather than from large capacity sources so as to limit the total quantity available in the event of a fire or explosion.

### 13.3 Plutonium Storage Facilities (PSF)

13.3.1 Combustible packaging materials should be stored in metal containers or structures outside of a PSF in a location that should not endanger the storage facility or stored material if a fire occurs in the packaging material. The need to provide automatic fire suppression systems for these areas should be evaluated in the SAR.

13.3.2 Storage racks should be noncombustible and designed to securely hold storage containers in place, ensure proper separation of storage containers, and maintain structural integrity under both normal operations and during a fire.

### 13.4 Enriched Uranium Storage Facilities (EUSF)

Combustible packaging materials should be stored in metal containers or structures outside of a UEUSF in a location that should not endanger the storage facility or stored material should a fire occur in the packaging material. The need to provide automatic fire suppression systems for these areas should be evaluated in the FHA and SAR.

### 13.5 Uranium Processing and Handling Facilities

13.5.1 The primary confinement system should be constructed of fire-resistant materials, and the process equipment and process being confined should be designed to prevent or minimize the probability of potential flammable or explosive conditions. Confinement enclosures for flammable metals should be designed with self-contained fire protection and extinguishing equipment; in some cases, inert atmospheres may be desirable within the enclosures.

13.5.2 The process should have ventilation that provides sufficient air movement around the process area to prevent exposure of personnel to the hazardous liquid or vapor. The design should incorporate roughing filters and/or other types of traps to remove entrained organic liquid droplets from the process off-gas before the off-gas enters the main ventilation ducting to prevent ventilation ducts from becoming coated with the organic material, and thus, creating a fire hazard.

### 13.6 Reprocessing Facilities

To ensure the maintenance of the principal confinement systems within secondary confinement, design features should include provisions for fire sprinklers, water fog, or other suitable fire protection systems. This will provide rapid heat removal, reducing both the pressurization of the process cell or canyon and loading of the ventilation system filters with combustion products.

### 13.7 Uranium Conversion and Recovery Facilities

13.7.1 To the extent practical, the primary confinement system should be constructed of fire-resistant materials, and the process equipment and process being confined should be designed to prevent or minimize the probability of potential flammable or explosive conditions. Confinement enclosures for flammable metals should be designed with self-contained fire protection and extinguishing equipment; in some cases, inert atmospheres may be desirable within the enclosures.

13.7.2 Physical isolation barriers should be designed for process areas that use hydrogen. Pressurized hydrogen gas storage areas should be surrounded with fire-resistant barriers. The pressurized hydrogen storage tanks should be capable of being isolated from the distribution system using positive shutoff valves. The distribution system should either be double-walled piped (pipe within a pipe) or have hydrogen detectors located at strategic points, with the detector-activated capability of shutting off hydrogen flow at the source.

13.7.3 Fire-resistant, physical isolation barriers should be designed for both the fluorine gas storage area and process areas that use fluorine.

## 14. NUCLEAR FILTER PLENUM FIRE PROTECTION

### 14.1 Purpose and Scope

- 14.1.1 Much of the information pertinent to fire protection for very high efficiency air cleaning filter plenums for nuclear applications is contained in technical papers, limited distribution reports, and job specifications that are often not readily available to DOE designers, facility managers, and fire protection engineers. This section provides personnel responsible for filter installations with practical fire protection guidelines for nuclear air cleaning final filter plenums. Collectively, this section summarizes findings from technical papers and job specifications currently used at DOE sites and information obtained from filter manufacturers to provide the user with the "best" methods and state of the art fire protection for protection of exhaust plenum final filter installations.
- 14.1.2 Although the guidelines in this section are specifically applicable when only high efficiency particulate air (HEPA) type filters serve as the final means of effluent cleaning in a nuclear air cleaning ventilation system, the guidelines can be applied with engineering discretion to other types of filtration and cleaning systems and their configurations.
- 14.1.3 This section does not include specific definitive fire protection design requirements for High Efficiency Metal Fiber filter systems, Radioiodine Adsorber air cleaning systems, Deep Bed Fiberglass filter systems, or Deep Bed Sand Filter systems (See ASME AG-1-1994, "Code on Nuclear Air and Gas Treatment" for definitions. Refer also to Appendix A). This section does not include the protection of HEPA type filters utilized in a clean room application. (Refer to NFPA 318.)

### 14.2 Filter Plenum Construction

#### 14.2.1 HEPA Filters

All HEPA filters used in nuclear ventilation exhaust systems should meet the requirements for HEPA filters in ASME AG-1, Section FC, and be listed as a High Efficiency Particulate Air Filter Unit as tested in accordance with UL 586. (Note: For operating temperatures of HEPA filters, see Appendix B).

#### 14.2.2 Duct Entrance and Prefilters

All nuclear duct entrance filters and prefilters located upstream or made part of final HEPA filter exhaust plenums should be listed as Class 1 Air Filters unit as tested in accordance with UL 900.

#### 14.2.3 Filter Framing

Filter framing systems may be constructed of combustible material provided that the material has a flame spread rating of 25 or less and smoke developed rating of 50 or less.

#### 14.2.4 Number of Final HEPA Filters

When nuclear HEPA filters serve as the final means of effluent cleaning, a minimum of two stages of HEPA filters should be arranged in series in the final filter plenum. In existing HEPA installations, one of the two stages of final HEPA filters may be located upstream from the final filter plenum.

### 14.3 Location of Final Filter Plenum Ventilation System Equipment

#### 14.3.1 Final Filter Plenums Located Inside Process Buildings

Filter plenums located inside process buildings and other buildings should be separated from all parts of the building and be enclosed by 2-hour fire-rated construction. Buildings should be provided with fire protection (i.e., smoke detector, sprinkler systems) for the appropriate particular hazards within the building.

#### 14.3.2 Final Filter Plenums Located in Separate Building

14.3.2.1 Separate buildings which house filter plenums should be of minimum 2-hour fire rated construction when located less than 5 feet (1.5 meters) from an adjacent building.

14.3.2.2 Filter plenum housing should be a minimum of 1-hour fire rated construction when located more than 5 feet (1.5 meters), but not more than 20 feet (6.1 meters) from an adjacent building.

14.3.2.3 Filter plenum housing located greater than 20 feet (6.1 meters) from an adjacent noncombustible building may be of unprotected noncombustible construction provided that no unprotected openings occur in the adjacent building.

14.3.2.4 Filter plenum housings need not be fire-rated or separated from an adjacent building if the adjacent building wall is of minimum 2-hour fire-rated construction with no unprotected openings.

#### 14.3.3 Filter Plenums Located Near Combustible/Flammable Liquids

Filter plenums located near combustible or flammable liquid storage buildings or tanks should be located not less than 50 feet away from the buildings or tanks and be housed in minimum 2-hour fire rated construction.

#### 14.3.4 Small Filter Plenums

Small filter plenums that serve as a final filter and have a leading surface area of 16 square feet (1.4 square meters) or less need not be separated by fire rated construction from other parts of a building or be located in a separate fire rated enclosure if the filter plenum is located in a building provided with an automatic fire sprinkler system, designed and installed in accordance with NFPA 13, and the filter plenum is provided with an automatic water spray system as described herein.

#### 14.3.5 Existing Plenums

Plenums that have already been built and are in service before issuance of these guidelines are not required to be upgraded with a fire-rated enclosure or minimum separation distance unless there is a significant hazard that endangers building occupants, the public, or the environment, as determined by an FHA per DOE Orders or is required by the AHJ.

#### 14.4 Protection of Openings in Fire Rated Construction

Fire protection features should be designed to maintain the integrity of containment systems as reflected in the SAR.

##### 14.4.1 Ratings for Doors

14.4.1.1 Door openings into 2-hour rated filter plenum housings should be 1 1/2-hour minimum fire-rated.

14.4.1.2 Door openings into 1-hour rated filter plenum housings should be 3/4-hour minimum fire-rated.

##### 14.4.2 Fire Damper Ratings

14.4.2.1 Listed 1 1/2-hour fire rated dampers should be installed where ventilation ducts, not required to continuously function as part of a confinement system, penetrate 2-hour fire rated construction.

14.4.2.2 Fire dampers are not required when ducting penetrates 1-hour fire rated construction. The duct should pass through the wall and extend into the area to be considered. The areas on either side of the wall should be completely protected by automatic sprinklers in order to eliminate the dampers. Transfer grills and other similar openings without ducting should be provided with an approved damper.

14.4.2.3 Fire dampers in duct work should not be utilized when penetrating the fire rated construction where the ducting is an integral part of the nuclear air filter system equipment that is required to continuously function as part of the confinement system. Such duct material penetrating fire rated construction without fire dampers should:

- o be made part of that fire-rated construction by either wrapping, spraying, or enclosing the duct with an approved material, or by other means of separating the duct material from other parts of the building with equivalent required fire-rated construction; or
- o be qualified by an engineering analysis for a 2-hour fire-rated exposure to the duct at the penetration location where the duct maintains integrity at the duct penetration with no flame penetration through the fire wall after a 2-hour fire exposure. (See Appendix D for a discussion of this type of analysis.)

14.4.2.4 Dampers in the air cleaning system for the purpose of controlling pressure, direction, or volume of air flow and for isolation of filters during change out or inspection are permitted in the ventilation system.

#### 14.4.3 Other Penetrations and Openings in Fire-Rated Enclosures

All mechanical and electrical penetrations made into fire-rated plenum enclosures should be fire stopped by listed materials meeting the requirements of ASTM E-814 with a fire rating not less than the rated enclosure.

### 14.5 Materials and Special Hazards Inside Plenums

#### 14.5.1 Combustibles Located Inside Filter Plenum Enclosures

Filter plenum enclosures should only be used for ventilation control equipment. The storage and accumulation of combustible materials as well as combustible and flammable liquids in any quantity should not be permitted. In addition, the storage of spare filters inside the filter plenum should not be permitted.

#### 14.5.2 Electrical Equipment Utilized in Final Filter Enclosures

All electrical equipment located in the filter plenum should comply with NFPA 70 and all electrical wiring located in the filter enclosure should be in metal conduit.

#### 14.5.3 Processes Subjecting Final Filter Plenum to Flammable and Combustible Vapors

14.5.3.1 When operations or processes involve flammable or combustible liquids that produce vapors, the concentration of the gases or vapors inside the final filter plenum should not exceed 25 percent of their lower flammable limit inside the filter enclosure.

14.5.3.2 Fixed combustible gas analyzers should be provided in the final filter enclosure when the process involves gases or vapor with analyzer alarms set to sound an alarm at 25 percent of the lower flammable limit. These alarms should be transmitted to a continuously manned location.

#### 14.5.4 Processes Subjecting Final Filter Plenum to Pyrophoric Dust Particles

When operations or processes involve pyrophoric materials that may subject the final filter plenum to the pyrophoric dust particles, a method to remove the dust particles before reaching the final filter enclosure, such as a prefilter, should be required.

#### 14.5.5 Processes Subjecting Final Filter Plenum to High Dust Loading, High Moisture Air, Acid, or Solvent Environments

Operations sometimes may involve processes that may subject the final filters to airstreams carrying high moisture content, high dust loading, acids, and solvents that may rapidly degrade, plug or disintegrate the final filter medium or separators. When operations involve these sorts of airstreams, preventive methods should be utilized to stop the degradation impact on the final filters. These can include, but are not limited to, more frequent filter change outs, prefilters, scrubbers or traps, filters rated for the particular environment, and the use of alternative chemicals. When chemical degraders to HEPA's are utilized, including hydrogen fluoride (HF), nitric acid (HNO<sub>3</sub>), and perchloric acid (HClO<sub>4</sub>), processes should include scrubbers, traps, or other methods to remove the chemical before the final HEPA filters.



## 14.6 Prefilters, Duct Entrance Filters, and Fire Screens

### 14.6.1 Prefilters and Duct Entrance Filters

Protection of the final filter plenum from dust and particulate loading should be accomplished by using duct entrance filters or prefilters or a combination of both as follows:

14.6.1.1 All gloveboxes, hot cells, and fume hoods connected to containment ventilation systems should be provided with at least moderately efficient (30 to 45 percent atmospheric dust spot efficiency based on ASHRAE 52-76) duct entrance filters.

14.6.1.2 High efficiency (at least 80 percent atmospheric dust spot efficiency based on ASHRAE 52-76 test method) prefilters should be provided in the ventilation system to protect the final HEPA filters from (1) particles with diameters larger than 1 or 2 microns; (2) lint; and (3) dust concentrations greater than 10 grains per 1,000 cubic feet (30 cubic meters). High efficiency prefilters not only provide a degree of fire protection to the final HEPA filters but can also extend the operational life of the HEPA filters.

14.6.1.3 Prefilters that should be located in final filter plenums enclosures should be high efficiency prefilters (at least 80 percent ASHRAE atmospheric dust spot efficiency). These prefilters should be located at least 36 inches (91 centimeters) upstream from the final HEPA filters.

14.6.1.4 Where airborne materials are known to be combustible (such as metal powders), replaceable prefilters should be located as near the source as possible. However, prefilters should not be located where there is an unacceptable radioactive hazard to personnel in changing the prefilters.

### 14.6.2 Fire Screens for Filter Plenums

14.6.2.1 Fire screens should be located upstream from the prefilters and final filter plenums.

14.6.2.2 Fire screens with metal meshes from 8 to 16 openings per inch should be provided and located at least 4 to 5 feet (1.2 to 1.5 meters) upstream from all prefilters and at least 20 feet (6.1 meters) upstream from all final filter plenum enclosures.<sup>1</sup>

---

<sup>1</sup> Numerical data obtained from:

Lee, H.A., *Final Report - Program for Fire Protection, Caves, Canyons, and Hot Cells*, ARH-ST-104, Atlantic Richfield Hanford Company, Richland, August 1974, pp. 59, 60.

Lee, H.A., *Guide to Fire Protection in Caves, Canyons, and Hot Cells*, ARH-3020, Atlantic Richfield Hanford Company, Richland, July 1974, pp. 33, 35.

Burchsted, C.A., J.E. Kahn and A.B. Fuller. 1976. *Nuclear Air Cleaning Handbook*, ERDA 76-21. Oak Ridge National Laboratory. Oak Ridge, Tennessee, pg. 227.

14.6.2.3 Where prefilters are located in final filter enclosures, fire screens should be located at least 20 feet (6.1 meters) upstream from the prefilters.

14.6.2.4 Duct entrance filters may not require fire screens unless a significant amount of combustible materials are present in the exhaust stream exiting the duct.

## 14.7 Detection Systems

### 14.7.1 Detectors

14.7.1.1 Automatic fire detectors should conform to NFPA 72, "National Fire Alarm Code."

14.7.1.2 Detectors should be rate compensated type heat detectors.

14.7.1.3 Detectors should be approved for the specified use.

14.7.1.4 Detectors should be of the 190 °F (89 °C) temperature range unless operations require higher temperature air flows (see Appendix B for maximum filter operating temperatures).

14.7.1.5 Existing detectors that are supervised, with suitable, equivalent, and reliable methods of detection (as determined by the AHJ) that are not rate compensated type or not listed may continue to be used while they remain serviceable.

### 14.7.2 Detector Location

14.7.2.1 Heat detectors or pilot sprinkler heads should be provided in ducting prior to final filter enclosures. Airflow should be considered when determining detector or pilot head location.

14.7.2.2 Heat detectors or pilot sprinkler heads should also be provided in the final filter enclosures.

14.7.2.3 If filter plenum automatic deluge spray systems are actuated by pilot sprinkler heads, heat detectors are not required in the ducting or the filter enclosure unless specified by the AHJ.

### 14.7.3 System Arrangement

14.7.3.1 The detection system or pilot system should be arranged to detect a rise in air flow temperatures, actuate automatic fire suppression systems, when required, and transmit an alarm to the responding fire department or constantly attended proprietary station. The fire alarm system should be installed per NFPA 72.

14.7.3.2 A pilot operated system should only be used when automatic water deluge spray systems are required under Section 14.8.

14.7.3.3 Control units and signaling alarm systems connected to the heat detectors should be listed for their intended purpose.

14.7.3.4 Existing detection systems or pilot systems that provide equivalent and reliable methods of detection and alarm signaling transmission (as determined by past performance and/or engineering analysis) that are electrically supervised but are not listed may continue to be used while they remain serviceable.

#### 14.7.4 Detection Testing Capability

14.7.4.1 Detector installations should be engineered and installed so that they can be tested during the life of the detector. Remote testing should be provided for detectors that are not accessible due to unacceptable hazards. One method of providing remote testing is to provide detectors with heating strips or coils that can be energized by a separate control unit. If a line-type heat detection system is used, a heat testing pad should be provided outside the plenum for operability testing of the system.

14.7.4.2 Where high contamination levels do not exist, detectors may be installed so that the detector can be removed from the plenum enclosure and tested externally.

### 14.8 Deluge Spray Suppression Systems

#### 14.8.1 Location

14.8.1.1 Automatic and manual water deluge spray systems should be provided inside all final filter plenums for protection of the filters where they have a leading filter surface area greater than 16 square feet (1.4 square meters).

14.8.1.2 Automatic water deluge spray systems should be provided inside all final filter plenums having a leading surface area of 16 square feet (1.4 square meters) or less when the filter plenum is not separated by fire rated construction.

14.8.1.3 Plenums that have already been built and are in service before issuance of these guidelines are not required to be backfitted with automatic or manual water deluge spray systems unless there is a significant hazard that endangers building occupants, the public, or the environment, as determined by an FHA or as required by the AHJ.

14.8.1.4 The design of water deluge spray systems should reflect the potential for filter failure mechanisms, such as filter media damage resulting from weakened media due to water absorption and excessive differential pressures during water discharge. Such failure mechanisms can be

significantly mitigated by throttling back fan controls to reduce the filter pressure or by providing redundant filters.

#### 14.8.2 Demister Guidelines

- 14.8.2.1 Where automatic deluge spray systems are installed in filter plenum enclosures that do not contain prefilters, metal demisters should be installed downstream of the automatic deluge spray sprinkler heads and upstream of the first series HEPA filter.
- 14.8.2.2 Demisters should have a nearly 100 weight (wt) percent efficiency for water drops 50 microns and larger. They should have an efficiency greater than 99 wt percent for 1 to 50 microns with air flow velocities of 500 to 600 feet (153 to 183 meters) per minute, or at operating air flow velocities with operating water flow deluge spray delivery rate.
- 14.8.2.3 Demisters should be located as far away as possible from the HEPA filters (a minimum of 36 inches [91 centimeters]) and approximately 6 inches (15 centimeters) from the deluge spray sprinkler heads.
- 14.8.2.4 When automatic deluge spray systems are installed in final filter plenum enclosures that contain prefilters, water spray deluge sprinkler heads should be located upstream from the prefilters. In this configuration, the prefilters act as a demister.

#### 14.8.3 Design of Automatic Deluge Spray Systems

- 14.8.3.1 Automatic deluge spray systems should be designed per the applicable provisions of NFPA 13 and NFPA 15, and as follows (see Appendix C):
  - o Density. Water spray density should be 0.25 gpm per sq. ft. over the entire filter area or 1 gpm per 500 cfm air flow, whichever is greater.
  - o Sprinkler head type. Spray sprinkler heads should be deluge type sprinkler heads.
  - o Location from prefilters or demisters. The spray pattern of the deluge sprinkler head should be in the form of a downward vertical water curtain approximately 6 inches (15 centimeters) in front of the prefilter or demister. In addition, deluge sprinkler heads should be spaced so that each sprinkler head does not exceed 4 lineal feet of curtain coverage.
  - o Activation by detection. Deluge spray sprinkler system should operate upon activation of fire alarm system heat detectors or pilot sprinkler heads located in either the final ducting or filter plenum housing. Manual activation should be provided as well.
- 14.8.3.2 Automatic water spray system equipment should be listed for its intended use as required by NFPA 13 and NFPA 15.

14.8.3.3 Existing automatic deluge spray systems that provide equivalent and reliable fire protection for plenum filtration systems (as determined by past performance and/or engineering analysis) may continue to be used while they remain serviceable.

#### 14.8.4 Design of Manual Deluge Spray Systems

14.8.4.1 Manual spray systems should be designed per NFPA 15 and modified as follows (see Appendix C):

- o Density. Water spray density should be 0.25 gpm per sq. ft over the entire filter area.
- o Spray pattern and nozzle type. Nozzles should be deluge spray nozzles that form a full circle solid cone discharge.
- o Location from filters. Spray nozzles should be horizontally directed at the face of the first series HEPA filters so that all areas of the first stage filters and framing support system are wetted.
- o Activation by manual operation only. Activation should be by manually activating deluge valve or opening a normally closed Outside Screw & Yoke gate valve. Control devices to activate the spray nozzle deluge valve should be provided in the process operators control room or other locations accessible to fire fighters. When a deluge valve is utilized, manual activation may be provided at the deluge valve as well.

14.8.4.2 Manual water spray system equipment should be listed for their intended use as required by NFPA 13 and NFPA 15.

14.8.4.3 Existing manual deluge spray systems that provide equivalent and reliable fire protection for plenum filtration systems are acceptable.

#### 14.8.5 Water Supply Guidelines

14.8.5.1 Water for the deluge spray systems should be provided by two separate water supply connections for reliability. (One may be a fire department connection if acceptable to the AHJ.)

14.8.5.2 Automatic and manual water spray system water supplies should be hydraulically calculated and capable of supplying a simultaneous flow of the automatic and manual water spray systems as well as the overhead ceiling automatic fire sprinkler systems for the fire area providing air to the plenum for a minimum period of 2 hours. A minimum 2-hour water supply is not required when a limited water supply system, discussed below, is justified and provided for criticality event reasons.

### 14.9 Special System Guidelines

#### 14.9.1 Water Drains

- 14.9.1.1 Water drains with traps and a means to eliminate drain trap evaporation should be provided in plenum floors to provide liquid run off control.
- 14.9.1.2 Plenum drains should be piped to either a process waste system or to collection tanks.
- 14.9.1.3 Process waste systems and collections tanks should be of sufficient capacity to capture all liquid from the water deluge spray systems for the densities and durations required herein.
- 14.9.1.4 Criticality safety should be observed in all drainage and storage systems where the potential for impacting fissile materials is encountered.

#### 14.9.2 Limited Water Supply Systems

- 14.9.2.1 Limited water supply systems for the deluge water supply should be permitted when a documented criticality potential exists in the final filter plenum.
- 14.9.2.2 A documented criticality potential should be provided showing criticality calculations and the total amount of water allowed in the plenum enclosure before a limited water supply system is permitted.
- 14.9.2.3 Limited water supply can be accomplished by either limited capacity water tanks or system water flow control valves.

#### 14.9.3 Maximum Air Temperatures

- 14.9.3.1 When normal operating temperatures of final filter enclosure are expected to exceed 200 °F (94 °C) or when operating temperatures of the final filter enclosure exceed the manufacturer's limited continuous service temperature rating, a method should be provided to cool the ventilation air stream (for filter operating temperatures see Appendix B).
- 14.9.3.2 Normal operating temperatures do not include high temperatures associated with fire conditions.
- 14.9.3.3 High operating temperatures in the final filter enclosure can be minimized by long runs of ducts preceding the final filter enclosure, by intake of dilution air from streams from other spaces, or by water cooling systems inside the ducts.

#### 14.9.4 Stainless Steel and Corrosion Resistant Equipment

- 14.9.4.1 Stainless steel or noncombustible corrosion resistant equipment should be provided for all ventilation metal parts required for fire protection where components in the ventilation system are exposed to corrosive atmospheres. They should be designed either with stainless steel or other non-reactive materials to ensure their resistance to the harmful effects of corrosion.

14.9.4.2 Stainless steel water spray heads and nozzles, piping and fittings in the plenum, piping hangers in the plenum, demisters, and teflon coated heat detectors are recommended.

14.9.4.3 Where a corrosion resistant or stainless steel fire protection product is required and that product is not available as a listed product from any manufacturer, the substitution of one product for another is acceptable provided that the replacement product is equivalent, based on an engineering analysis.

#### 14.9.5 Lighting and Window Viewing Ports

14.9.5.1 Lighting should be provided inside the filter plenum in front or between the filter banks in the area where automatic and manual heads and nozzles are located. Such lighting may be provided with an on and off switch provided that the switch is located outside the plenum at an accessible location.

14.9.5.2 Window viewing ports made up of either wire glass, laminated lead safety glass, or fire rated glass should be provided for viewing inside the filter plenum. The window viewing ports should be provided at each location where fire protection spray system heads and nozzles are located and should be placed in such a way with enough windows so all heads and nozzles are visible from outside the filter plenum.

#### 14.10 Fire Hazard Analysis

It is not the intent of this Standard to prevent the application of alternative methods that provide equivalent or superior fire protection for nuclear final filter plenums. Therefore, equivalencies from fire protection guidelines provided in this section are permitted. However, equivalencies should only be permitted when a documented fire hazard analysis has been performed in accordance with DOE Orders (See also the DOE Fire Protection Program Implementation Guide and the DOE Fire Protection Handbook.) and the FHA is reviewed and approved by the AHJ.

## 15. GLOVEBOX FIRE PROTECTION

### 15.1 Scope

#### 15.1.1 Gloveboxes and Hot Cells

15.1.1.1 This section provides fire protection requirements for the design and construction of all new gloveboxes. It also addresses extinguishing methods, ventilation protection features, and general operating safeguards.

15.1.1.2 This standard is not intended for hot cells, although some design principles in this document may prove useful if similar hazards are present. Consult a qualified fire protection engineer before applying these criteria to hot cells.

15.1.1.3 If the use of the glovebox is to change or the glovebox is removed from service, an FHA should be performed to evaluate the potential fire hazards associated with the change.

#### 15.1.2 Existing Glovebox Installations

These criteria apply to existing glovebox installations when an FHA demonstrates conditions that warrant their application, or when determined by the AHJ.

#### 15.1.3 Table-Top Gloveboxes

Sections 15.3 and 15.5 do not apply to single, table-top, or mobile-type gloveboxes unless the potential fire hazards associated with these units warrant applying these sections to those installations.

#### 15.1.4 Automatic Fire Protection Required

An automatic fire suppression or inerting system is required in all new gloveboxes unless an FHA concludes that such a system is not warranted, and except as noted in 15.1.3 above.

### 15.2 Glovebox Construction

#### 15.2.1 Noncombustible Materials

15.2.1.1 Gloveboxes should be constructed of noncombustible materials. The most common materials used are stainless steel and glass.

15.2.1.2 If the atmosphere and/or process within the glovebox is incompatible with the construction material of the box, an epoxy resin with inorganic fillers may be used to coat the interior metal surfaces of the glovebox. Where plastic linings are used for this purpose, the glovebox enclosure should be protected by either an automatic fire suppression system or an inert atmosphere system in accordance with the applicable NFPA Standard as supplemented by this standard.



15.2.1.3 All radiation shielding material added to the glovebox should be noncombustible. If combustible material must be used, it should be encased with a noncombustible material.

## 15.2.2 Glovebox Windows

The number of glovebox windows should be limited to that required to provide the visibility necessary to ensure that safe operations, cleanup, and maintenance activities can be performed.

### 15.2.2.1 Window Materials

- o Glovebox windows should be constructed of wire glass, fire-rated glass, or laminated safety glass. The window gasketing material should be noncombustible, fire-retardant treated, or heat resistant. A comparison of glovebox window material is provided in Appendix I.
- o If laminated safety glass is used in locations where radiation levels may be high enough to cause yellowing of the plastic, a cerium additive should be specified to prevent yellowing of the plastic laminate.
- o If either the glovebox atmosphere or operations require that an alternate window material be used, fire-retardant treated polycarbonate may be used. If fire retardant polycarbonate must be used, it should be sandwiched with noncombustible material (such as wire or tempered glass) whenever possible. As an alternative, the exterior side of the polycarbonate should be protected with a noncombustible material to guard against the effects of exposure fires.

## 15.2.3 Gloveports

15.2.3.1 Gloveports should be installed in the stainless steel sides of the glovebox. If this is not possible, the gloveports should be installed using laminated safety glass or a fire retardant polycarbonate plastic and the quantity of plastic used should be limited only to that required to safely mount the gloveports.

15.2.3.2 Metal covers should be provided for each of the glove openings. Covers should be constructed of stainless or carbon steel. The covers should be held in place by a latch or other device constructed of noncombustible material suitable for the application. Utilization of the glovebox covers serves to protect against loss of integrity at a gloveport due to either internal or external fire exposure.

15.2.3.3 Noncombustible covers or plugs should be used to seal gloveport openings if the gloves have been removed.

## 15.2.4 Gloves

15.2.4.1 Glovebox gloves should be selected based on the chemicals present in the glovebox. Generally, hypalon<sup>2</sup> or neoprene gloves are used where permeation from the chemicals present is not a consideration. An additional outer cover may be provided if required for operational or personnel safety needs.

15.2.4.2 Gloves should be at least .030 inches (.076 centimeters) thick and should be of one-piece construction.

#### 15.2.5 Methods for Containing Fire Spread

15.2.5.1 Glovebox ventilation ducting should be provided with separation/isolation dampers or doors to minimize fire propagation. Fire barriers should also be provided between individual or groups of gloveboxes and within glovelines where warranted by the FHA.

15.2.5.2 The separation/isolation dampers or doors should shut by a fusible device. Where the glovebox is protected by an automatic fire suppression or detection system, the dampers or doors should be equipped to close upon activation of the system in lieu of providing conventional fusible devices. In the case of fire detection systems, precautions such as heat detectors or dual zone smoke detectors should be utilized so as to avoid inadvertent operation and subsequent shutdown of the glovebox ventilation system.

15.2.5.3 Fire hazards analyses in combination with other ventilation and contamination control analyses should be used to determine where these separations are required. While specific guidance cannot be given due to the variety of glovebox applications, fire separation features should be considered for the following glovebox locations/situations:

- o Where required in conjunction with automatic fire suppression systems.
- o At the connection point between the glovebox and its ventilation exhaust duct.
- o At the connection point between a glovebox and a gloveline.
- o Between gloveboxes or banks of gloveboxes which are connected in series, particularly where the glovebox run crosses physical barriers which would serve as a fire stop to prevent fire propagation.
- o Unique situations where it is desirable to prevent fire propagation within a group of gloveboxes, or between a glovebox(s) and other areas.

---

<sup>2</sup> Trademark of E. I. du Pont de Nemours & Company.

- o The contents of gloveboxes and the need to limit contamination spread due to a fire is an important consideration in determining the number and location of separation devices.

#### 15.2.6 Criticality Safety Provisions

15.2.6.1 Floor drains should be provided for all gloveboxes in which a criticality, process safety, or other similar engineering analysis determines that operations within a glovebox can create the potential for a criticality incident.

15.2.6.2 Where criticality is a concern and a drain system provided, the glovebox drain system design should provide for liquid collection/containment. Containment methods may include tanks, diked floors, etc. In addition, the drain piping and liquid collection systems/equipment should be designed to avoid criticality incidents.

#### 15.2.7 Glovebox Utilities and Services

15.2.7.1 All electrical components in the glovebox design should comply with the applicable sections of NFPA 70, National Electrical Code.

15.2.7.2 Utilities (e.g., water, air, gas, etc.) serving gloveboxes should be provided with shutoff or isolation valves for use in the event of an emergency. These valves should be located so as to permit rapid operator action while simultaneously protecting the operator from the emergency itself in or adjacent to the glovebox.

15.2.7.3 All heating devices used inside gloveboxes (such as hot plates, furnaces, etc.) should be listed/approved and equipped with automatic high-temperature shutoff switches. Where the presence of hazardous conditions warrant, the FHA should consider the need for high temperature alarms to be transmitted to a constantly attended location.

### 15.3 Automatic Fire Suppression and Inerting Systems

#### 15.3.1 Inerting Systems

##### 15.3.1.1 General

Gloveboxes should be provided with inert atmospheres when:

- o combustible or pyrophoric metals are in use in significant quantities as determined by the AHJ; and
- o required by the FHA or SAR.

Glove box inerting may be used in lieu of an automatic fire suppression system when conditions warrant.

##### 15.3.1.2 Inerting System Design Guidelines

- o The system should be designed and installed in accordance with the applicable industry standards as supplemented by DOE criteria.
- o When required or when used as a substitute for other required automatic fire suppression systems, gloveboxes should be purged with an inert gas (commonly argon or nitrogen). The level of inerting provided should be sufficient to prevent ignition of the material(s) present. A safety factor should be included in establishing the inert gas design concentration. The safety factor compensates for errors in instrumentation or other conditions which might lead to an increase in oxygen level. For deflagration prevention, the flammable/combustible concentrations should be maintained at or below 25 per cent of their lower flammable limit. For combustible and pyrophoric metals, the oxygen concentration should not exceed 25 per cent of the level required for combustion. (Note that some combustible metals (e.g., aluminum powder) will burn in atmospheres other than air. Thus it is important for the designer to select an appropriate inert gas and establish a design concentration based upon the hazard.)

#### 15.3.1.3 Oxygen Monitoring

Where inert gas purging systems are installed, oxygen monitors should be provided to ensure the necessary concentration of inert gas is maintained.

If an alarm (excess oxygen) condition is reached in the glovebox, the oxygen monitoring system should:

- o shut down the operations and electrical power to the glovebox, when warranted by the FHA, provided this action does not create an additional hazard; and
- o activate a local audible alarm (as a minimum) and, if high noise levels or other conditions warrant, cause a local visual alarm to be activated.

The designer and fire protection engineer should also evaluate gloveboxes equipped with inert gas purging systems to determine if:

- o an emergency purge or pressure relief system should be installed; and
- o the hazard justifies providing annunciation at a continuously staffed location.

*NOTE: The designer must analyze the consequences of curtailing operations after an oxygen alarm and establish the procedure necessary to shut down and stabilize conditions in the glovebox following an alarm.*

#### 15.3.1.4 Oxygen Deficient Atmospheres

Where justified by the hazards analysis, equipment to continuously monitor oxygen levels should be provided for working areas of facilities which are or may be occupied by personnel and which are equipped with gloveboxes or glovebox lines having inerted or oxygen deficient atmospheres. This should include pit or below grade areas where glovebox inerting gases may concentrate.

### 15.3.2 Automatic Fire Suppression Systems

#### 15.3.2.1 System Types and Selection

Automatic sprinkler or other approved fire suppression systems (foam water, dry chemical, dry powder, gaseous, water mist, etc.) should be provided for gloveboxes in which flammable/combustible liquids, oxidizers, or waste characterization operations are involved, except where an inerting system is provided per this standard. All systems should be designed, installed, acceptance-tested, and maintained in accordance with the applicable NFPA standards (see Section 3.0).

The following considerations apply:

- o Limited water supply sprinkler systems may be used if criticality is a potential (see Appendix H).
- o Gloveboxes should be provided with liquid runoff control if automatic sprinkler protection is provided.
- o Restricted orifice sprinkler heads may be used.
- o In designing the distribution system for dry chemical systems, nozzles should be so oriented as to direct the discharge away from exhaust filters. This design step prevents direct loading of the filter by the dry chemical discharge.
- o The extinguishing systems should sound local alarms and transmit remote alarms to a continuously attended location for the purpose of initiating emergency action.
- o Listed/approved "on-off" sprinklers may be used.

#### 15.3.2.2 Design Considerations

In selecting the type of automatic fire suppression system for installation in a glovebox under this standard, the designer should, as a minimum, consider the following:

- o potential for criticality;
- o potential for contamination spread;
- o effectiveness of the fire extinguishing agent on the anticipated type of fire;

- o impact of the fire extinguishing agent on HEPA filters;
- o potential for overpressurizing the glovebox due to activation of the extinguishing system;
- o anticipated changes in glovebox use or operations which will increase the level of fire hazard; and
- o potential for inadvertent operation and the anticipated consequences.

#### 15.3.2.3 Existing Halon Fire Suppression Systems

Existing halon fire suppression systems which protect gloveboxes may continue in service if all of the following criteria are met:

- o The system is considered "essential" under Environmental Protection Agency regulations. (See also the Guidance on the DOE Facility Phaseout of Ozone-Depleting Substances, October 1995.)
- o The glovebox is required to have an automatic fire suppression system.
- o The system complies with NFPA Standard 12A.
- o The system is designed for automatic operation. The detection method should be designed to prevent inadvertent operation. (The use of "deadman" abort switches is acceptable.)

Existing halon fire suppression systems which do not meet the above criteria should be replaced with a suitable automatic fire suppression system.

#### 15.3.3 Multiple Hazard Gloveboxes

If a glovebox operation involves multiple hazards (such as pyrophoric metal and flammable/combustible liquids), the FHA should determine the fire protection system design that provides the best overall protection.

#### 15.3.4 Special Hazards

Gloveboxes in which other special hazards are present (such as biohazards, medical or industrial toxins, flammable solids, water reactive materials, etc.) should be equipped with fire protection as determined by the FHA. At a minimum, this protection should consist of an automatic fire detection system complying with NFPA Standard 72 and the guidelines in Section 15.5 of this standard.

#### 15.3.5 Gloveboxes Removed from Service

15.3.5.1 Fire suppression and inerting systems are not required to be maintained in gloveboxes which are removed from service provided that the following provisions are met:

- o All combustible materials are removed from the glovebox.
- o Electrical power and flammable/combustible utilities are isolated and tagged "out-of-service."
- o The glovebox is tagged "out-of-service."

15.3.5.2 Resumption of activities within the glovebox should only be allowed after appropriate fire protection features have been reactivated on the basis of an updated FHA.

## 15.4 Manual Fire Suppression

### 15.4.1 Manual Fire Fighting

15.4.1.1 All glovebox designs should include provisions for manual fire fighting. The extinguishing agent(s) selected should be appropriate for the hazards.

15.4.1.2 Where the potential for metal fires is present, an appropriate fire extinguishing agent (e.g., magnesium oxide sand, copper metal powder (30 - 60 mesh), carbon microspheres) in sufficient quantity should be provided. (Refer to Appendix G for an illustration of a mounting concept for a dry powder container.) In selecting the fire extinguishing agent, consideration should be given to the ease at which the metal can be separated from the agent. This is particularly relevant in the case of plutonium.

15.4.1.3 Where the fire potential is from other (non-metal) combustibles, dry chemical extinguishers are recommended. CO<sub>2</sub> extinguishers may also be considered if class A combustibles are not a hazard in the glovebox. If grouped cables are present and water does not create the possibility of a criticality, then water should be used.

15.4.1.4 In selecting the type of manual fire extinguishing unit and the application of extinguishing agent within the glovebox, the designer should consider:

- o the potential for glovebox overpressurization;
- o the effect of fire extinguishing agent on filters; and
- o the potential for increased contamination spread.

### 15.4.2 Quick-Disconnect Couplings

15.4.2.1 Where manual suppression is the primary fire suppression method for the glovebox, pre-piped discharge points equipped with quick-connect couplings should be provided to facilitate the use of portable fire extinguishers. These couplings should be installed so that the extinguisher discharge is directed away from the exhaust filtration. (Tests have shown that a single disconnect coupling supplied by a 5 lb. [2.25 kilograms] dry chemical extinguisher can cover approximately 18

square feet [1.62 square meters].) Details of a quick connect coupling are provided in Appendix F.

15.4.2.2 If access is a problem, extension tubes or pipes that extend to accessible areas should be used to provide coverage for areas where it is difficult to reach the quick disconnect couplings.

15.4.2.3 Fire extinguishers with bayonet-type connectors may be used when it is not feasible to install quick-disconnect couplings. However, the designer should document the basis for not installing quick-disconnect couplings in the design report.

## 15.5 Fire Detection Systems

Gloveboxes should be provided with an automatic fire detection system. (Refer to Appendix E for examples of glovebox fire detection systems.) A separate detection system is not required if the glovebox is equipped with an automatic fire suppression system that includes alarm features or an inerting system with alarm features.

15.5.1 The type of fire detection system to be used should be determined based on the hazards associated with the glovebox and operational needs. Air flow patterns within the glovebox should be considered when selecting and locating devices.

15.5.2 Fire detection systems should be designed, installed, acceptance-tested, and maintained in accordance with the applicable NFPA Standards.

15.5.3 If used, spot-type heat detectors should be installed not more than 8 feet (2.4 meters) apart.

15.5.4 Heat detection-type systems should be provided with remote testing capabilities.

15.5.5 A means should be provided to safely perform required inspection, testing and maintenance on the fire detection system installed in the glovebox.

15.5.6 Detection systems should sound local alarms and transmit remote alarms to a continuously attended location to initiate emergency action.

## 15.6 Glovebox Ventilation

The criteria of this section are for gloveboxes and glovebox exhaust connections. For criteria for filter plenums and ventilation systems beyond the gloveboxes, refer to Section 14 of this standard.



### 15.6.1 Ventilation Design to Include Fire Protection Factors

15.6.1.1 Glovebox ventilation requirements should be based, in part, on the results of the hazards analysis. Glovebox ventilation systems should be protected against the effects of fire.

15.6.1.2 Where feasible, glovebox ventilation should incorporate a downdraft design (that is, the ventilation inlet opening should be near the top of the box and the exhaust opening should be near the bottom of the box). Studies have shown that downdraft construction is best from a fire protection viewpoint, and it should be used unless operational features dictate otherwise.

### 15.6.2 Exhaust Filters and Screens

Glovebox primary exhaust openings should be provided with prefilters and fire screens to reduce vapor mist and fire propagation. The fire screens should be stainless steel screens (8 -16 mesh) or a perforated stainless steel plate using the same mesh opening sizes. The screens should be installed at the primary exhaust openings.

### 15.6.3 Flow Rate Considerations

15.6.3.1 Glovebox ventilation flow rates in gloveboxes having an air atmosphere and in which flammable liquids or gases are used should be sufficient to prevent the atmosphere from reaching 25 percent of the lower flammable limit of the material in use. Maintaining oxygen concentrations at or below 25 percent of the lower flammability limit provides a safety factor against equipment malfunctions, accidental leaks, etc., which could lead to increases in the glovebox oxygen concentration.

15.6.3.2 Where hot plates or other heat sources are used in the glovebox, flow rates higher than that stipulated above may be required in order to prevent unacceptable overheating of the glovebox enclosure. Temperature increases which do not exceed 15 degrees above ambient room temperatures are, generally, acceptable.

### 15.6.4 Ventilation Exhaust

Exhaust air from gloveboxes containing flammable or other hazardous atmospheres should be discharged to the outdoors. Such emissions should comply with applicable Federal and State emissions requirements.

### 15.6.5 Ventilation Overpressure Protection

The designer should evaluate whether "dump valves" or other control equipment are required to prevent glovebox over-pressurization if the primary exhaust system fails, if there is a breach in the glovebox, internal pressurization or similar

event occurs. Rapid changes in atmospheric conditions may also result in over- or under-pressurization of the glovebox (see Appendix J).

#### 15.6.6 Multi-Unit Exhaust Manifolds

Glovebox exhaust ventilation lines should be designed so each box has its own exhaust port. The purpose of this criterion is to prevent flame or hot fire gases from traveling from one glovebox to another through a common header or interconnection arrangement.

#### 15.6.7 Noncombustible Materials

Noncombustible materials should be used for glovebox ventilation ducts regardless of duct type (rigid or flexible). Insulation materials used to wrap/cover ventilation ducts should also be of noncombustible material such as fiberglass.

## Appendix A. Nuclear Filtration and Air Cleaning Systems

Other types of nuclear filtration systems and air cleaning systems mentioned in this document:

### High Efficiency Metal Fiber Filter Systems

This type of filtering has only been commercially available in the United States since the mid-1980s. High Efficiency Metal Fiber (HEMF) filters are made of sintered stainless steel fibers that are welded into steel housings and steel frames. HEMF filters are generally not disposed of when they become plugged or "loaded" like HEPA filters because they can be cleaned by following a manufacturer's cleaning procedure. After cleaning a dirty, used HEMF filter, there is little or no effect in the filter's efficiency and structural integrity when compared to that filter's original efficiency and structure.

In contrast to HEPA filters, metal fiber filters are not weakened by moisture impingement. Also, HEMF filters can operate for longer and hotter time periods than HEPA filters because the metal filters contain no flammable components and they are inherently resistant to high temperatures (although the finely divided filter media in a metal filter will not resist a direct flame impingement). The resistance of it to moisture and heat make this filter attractive for fire protection purposes. Since the use of HEMF filters is relatively new to the DOE community, little fire protection design data based on actual fire testing are currently available.

### Radioiodine Adsorber Air Cleaning Systems

Although much discussion in the nuclear community has been generated for the past 40 years as to fire protection of adsorbers, little consensus and few conclusions as to the proper method of extinguishment of adsorber fires involving combustible materials has been achieved. Some methods include utilizing a combination of manual and automatic water spray systems, limiting air flow to the adsorbers, and the utilization of alternative non-combustible adsorber medias such as silver zeolite. Adsorber air cleaning systems are often utilized in nuclear reactor emergency ventilation confinement systems where they are often referred to as charcoal or carbon type filters (but other inorganic adsorber materials are available for adsorber media such as silver oxide, silver nitrate, aluminum silicate, and silver zeolite). Although the nuclear industry has experienced less than six known adsorber fires in its history, it is generally accepted that as a minimum, adsorbers should be provided with fire detection equipment.

For carbon type filters an insurance carrier<sup>3</sup> for nuclear power plants recommends the following fire protection:

- a. A hydraulically designed automatic water spray system, utilizing directional solid-cone spray nozzles controlled by an approved deluge valve, with remote suitably located manual actuation stations, should be provided for charcoal filters.
- b. The spray nozzles for horizontal beds or drawers should be oriented above each bed or drawer and be of such design to distribute water evenly across the top of each bed or drawer at a minimum density of 0.25 gallons per minute per square foot.

---

<sup>3</sup> J. J. Carney, *ANI's Recommendations for Carbon Filters*, American Nuclear Insurers, C.3.1, September 1977.

- c. The spray nozzles for vertical beds should be oriented at the top of the bed and be of such design to distribute water evenly across the top of the bed at the rate of 3.2 gallons per minute per cubic foot of charcoal bed.
- d. A supervised fixed temperature detection system should be provided and connected to an annunciator in the control room. The detectors should be located on the down stream side of the charcoal bed for automatic operation of the spray systems.
- e. The spray system should be equipped with a local alarm and connected to an annunciator in the control room.
- f. The air flow should terminate (fan shut off) upon water activation.
- g. For the pressure vessel type charcoal filter, where a shut-off by-pass arrangement is employed around each tank, an automatic water spray system is not required. We [the insurance carrier] recommend a hose connection be available on the side of the tank to allow the introduction of water.

#### Deep Bed Fiberglass Filter Systems

One method investigated to extinguish fiberglass filter fires was water spray systems. Early designs of deep bed fiberglass filters did not address filter media replacement, and over a period of years, the fiberglass filters plugged to the extent that the systems could not meet ventilation airflow requirements. Water sprays and steam were applied to the filters for cleaning the plugged filters, but with little success. It is generally accepted that water applied to this type of filter media in the event of fire could extinguish the fire. However, accumulation of radioactive material present in the filter media would still be released to the environment when the water is applied.

Since the goal of ventilation systems is to continue to perform their safety functions effectively under all conditions by confining radioactive or other potentially dangerous materials and the efficiency of deep bed fiberglass filter systems is generally not adequate, these type of filters must be accompanied by additional downstream filters such as a HEPA.

#### Deep Bed Sand Filter Systems

For the most part, sand filters are fire resistant, chemically inert, and require no special fire protection systems. Sand filters are usually accompanied by HEPA filters. When a sand filter is used in series with HEPA filters it should be upstream of the HEPA. In this position, the sand filter can protect the HEPA filters that provide the final containment barrier.

#### Self-Cleaning Viscous Liquid Filters

These types of filters utilize a viscous liquid for cleaning purposes. They should be avoided for uses where radioactive materials are handled because they produce radioactive sludge that requires disposal. These types of filters would also require special fire protection systems because of the combustible nature of the liquid.

#### Moving Curtain Single Pass Rolling Prefilters

One noteworthy type of prefilter is the moving curtain single pass rolling prefilter. This type of prefilter involves fresh filter media being manually or automatically fed across the face of the filter, while the dirty media is rewound onto a take up roll. When the roll is exhausted, the take up media

is disposed of and a new media roll is then installed. Fire tests involving this type of prefiltering were performed in 1980 by Lawrence Livermore National Laboratory utilizing a modified commercial moving curtain filter. The purpose of testing this type of filter was to find a way to limit the amount or eliminate aerosol smoke that may be produced in a fire that can plug a final HEPA filter. The tests demonstrated that prefilters of this type could limit aerosol plugging of HEPA filters produced during fire. However, the subject final test report stated that prefilters of this type were an "experimental prototype" and that this type of prefilter "would have limited application as a pure fire protection device" for containment ventilation systems in current use.<sup>4</sup>

### Electrostatic Precipitator Prefilter

Another type of prefilter that has been utilized at DOE facilities is the electrostatic precipitator (ESP) prefilter. This prefilter imparts an electrical charge to particles in the air flow stream, causing the particles to adhere to collector plates. The ESP prefilter has been used to extend the life of final HEPA filters when processes involve larger diameter airflow particles. A certain level of fire protection could be achieved with an ESP prefilter during a fire if the particles expected as products of combustion can be properly collected on the filter throughout the fire for the particular air flow capacity of the process. Most commercially available ESP prefilters cannot catch the smaller airborne particles and smoke particles associated with a burning fire. However, more work needs to be done on ESP prefilters to understand what particle sizes associated with fire an ESP can effectively filter out. When ESP prefilters are used they should be made of noncombustible materials and, as with any prefilter, careful attention should be directed to prevent dust loading on it during its use. Also, ESP prefilters should not be used where explosive concentrations of gases or dusts are present.

---

<sup>4</sup> Alvares, N., D. Beason, W. Bergman, J. Creighton, H. Ford, and A. Lipska. 1980. *Fire Protection Countermeasures for Containment Ventilation*, UCID-18781, Lawrence Livermore National Laboratory, Livermore, California

## **Appendix B. Operating Temperatures for HEPA Filters**

To be listed by Underwriters Laboratories under UL-586 as a High Efficiency Particulate Air Filter Unit, HEPA filters are required to: (1) withstand 750 °F (402 °C) air for 5 minutes at rated airflow capacity and have greater than 97% DOP efficiency, and (2) withstand a spot-flame test in which a Bunsen burner flame is placed on the filter core with no after burning when the flame is removed.

However, it can be noted that there is a rapid decrease in the tensile strength of the filter media at about 450 °F (234 °C), and when temperatures get above 800 °F (430 °C) the fibers in the filters begin to break and curl up leaving pinholes in the filter media. Extended exposure to temperatures above 800 °F (430 °C) will cause destruction of the case in wood-cased filters and warping of the case in steel-cased filters, resulting in bypassing of unfiltered air.

Although HEPA filters can withstand 750 °F (402 °C) temperature for a very limited time duration, they should not be subjected to indefinite exposure temperatures higher than 275 °F (136 °C). Longer filter life and more reliable service as well as an operational safety factor can be obtained when normal operating temperatures are below 200 °F (94 °C) and high temperature extremes are avoided.

Continuous operation of HEPA filters at higher temperatures is limited primarily by the filter sealant, used to seal the filter core into the filter case. At higher temperatures, the sealants lose their strength, causing filter failure. For example, standard urethane seals are suitable for service at 250 °F (122 °C), while some silicone seals can withstand 500 °F (262 °C).

Since different sealants are available and different filter manufacturer's rate their filters for different temperatures, the best practice is for ventilation system designers and operators to determine the manufacturers limiting continuous service temperature if continuous operation at high temperatures are necessary.

**Appendix C. General Criteria Summary Table and Plan Diagram**

**Table C.1. General Criteria Summary Table  
Required by this Document**

<b>General Criteria</b>	<b>Existing Plenum</b>	<b>New plenums ≤ 16 sq. ft. (1.4 sq. meters)</b>	<b>New Plenums &gt; 16 sq. ft. (1.4 sq. meters)</b>
Combustible filter frame allowed?	Yes	Yes	Yes
Rated enclosure or separation required?	No <sup>1</sup>	No <sup>2</sup>	Yes
Fire detection or pilot sprinklers required in intake ducting?	Yes	Yes	Yes
Water spray systems required?	No <sup>1</sup>	No <sup>3</sup>	Yes

<sup>1</sup> Unless required by authority having jurisdiction .

<sup>2</sup> Separation not required if ceiling sprinklers provided in plenum location and in plenum .

<sup>3</sup> Provided that filters are separated by fire rated construction.

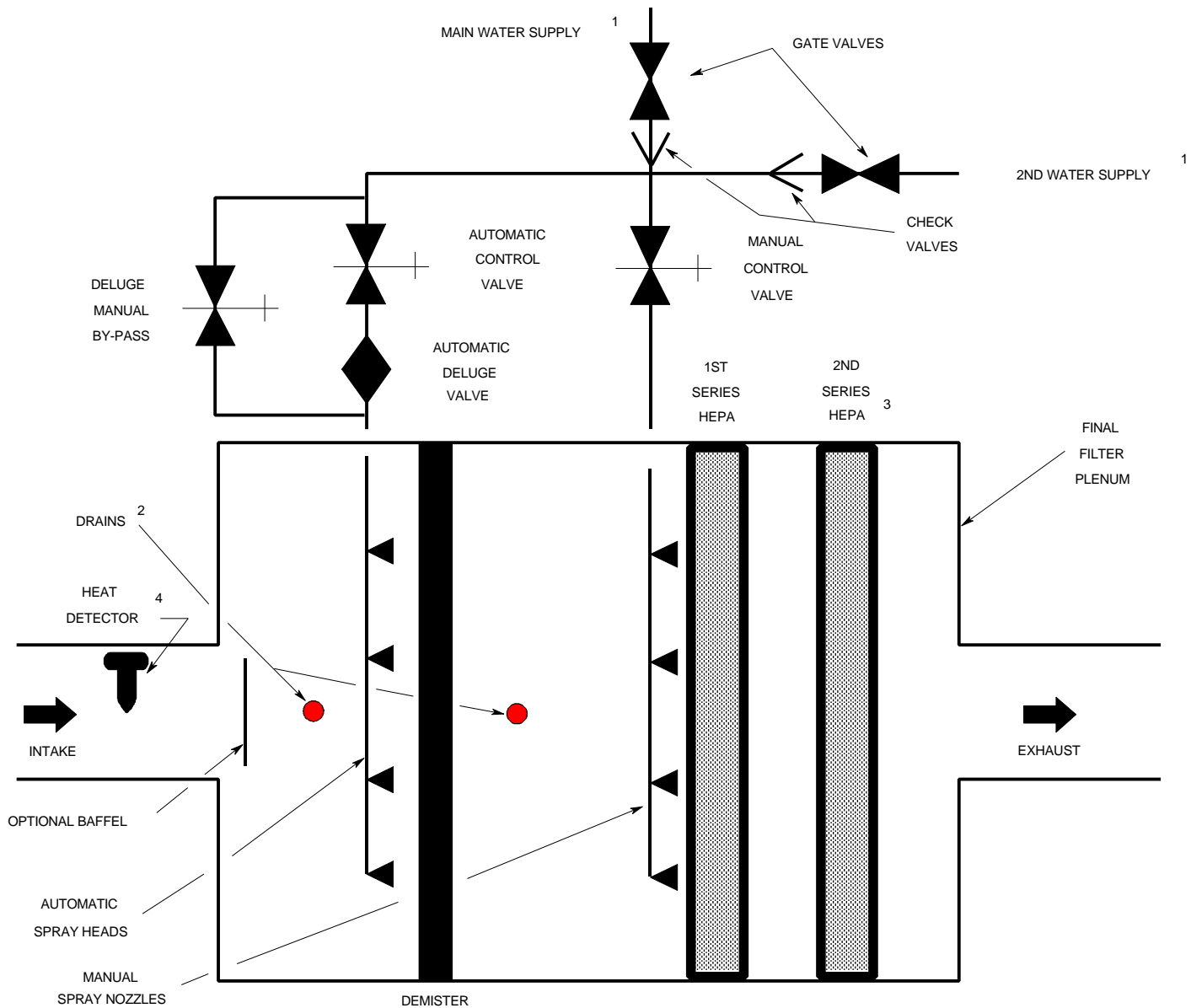

**Figure C.1. Plan Diagram of Filter Plenum Fire Protection  
(Diagram for reference purposes only. See written criteria for actual requirements)**

<sup>1</sup> Water supply may be a limited water supply. Secondary supply may not be required.

<sup>2</sup> Pipe drains to either a process waste system or collection tanks.

<sup>3</sup> Minimum two stages of HEPA filters required. Additional stages of HEPAs are permitted.

<sup>4</sup> Pilot sprinkler heads may be used to activate deluge system. Heat detection also required in final filter enclosure .



## Appendix D. Discussion on Evaluating Duct Openings When Penetrating 2-Hour Fire Walls

It is recognized by fire protection practices that fire dampers are not required in all cases when HVAC ducting penetrates fire rated construction. In NFPA 90A, Standard for the Installation of Air Conditioning and Ventilating Systems, 1989 Edition, Section 3-3.1, fire dampers are not required when ducts penetrate fire rated barriers that have a resistance rating less than 2 hours.

However, NFPA 90A (Sections 3-3.1.1 and 3-4.1) requires 1 1/2-hour fire-rated dampers in ducts which penetrate fire barriers of 2 hours fire resistance or greater (but less than 3 hours). Section 3-4.2 of NFPA 90A requires 3-hour fire-rated dampers in ducts which penetrate barriers having a fire resistance of 3 hours or more.

The listing criteria for fire dampers, specified in UL 555, requires fire dampers to be tested in an assembly with a standard time temperature fire exposure. The criteria for a damper passing the UL 555 test requires that the damper remains closed during the duration of the fire test following a hose stream test where no flaming on the damper materials and no through openings that would allow flames to penetrate the fire wall occur.

In the UL 555 test, no duct work is connected to either side of the fire wall where the damper is tested because it is assumed that in a worst case situation the duct work will structurally fail, fall away from the damper, and only the fire damper and housing will remain.

Using the passing criteria defined in UL 555, researchers<sup>5 6</sup> have proposed equivalent protection of duct openings with no fire damper installed where the duct remains intact near the wall opening creating a barrier to flames passing through the opening at the end of a 2-hour fire test.

The research has demonstrated that the most important factors in maintaining the integrity of the ducting that prevents flaming through the duct opening after a one hour fire exposure is the quality of the duct construction and installation, a design which prevents gaps between the fire wall opening and the duct, and the design and protection of the duct hangers so that the ducts are supported throughout the fire period and hose stream test near the wall opening where the penetration occurs.

Full scale fire testing has demonstrated that specific size and design detailed for both rectangular and round ducts, installed per HVAC Duct Construction Standards, Metal and Flexible, will remain in place over a 2-hour standard time temperature fire exposure.

The cited research addresses other methods to analyze duct penetrations in fire walls where fire dampers are excluded so that qualified engineers and designers can assess and qualify by engineering analysis other design scenarios for ducts not tested in the full scale tests performed by the researchers.

The research did not rely on trade-offs such as sprinkler protection as a method for qualifying the ducts. It was based on quantitative engineering equations and tools and fire test data. The research is not applicable to ducts that contain combustible loading and did not address protection of openings in smoke barriers.

---

<sup>5</sup> Gewain, R., J. Shanley, P. DiNenno, J. Scheffey, B. Campbell. August 1991. *Evaluation of Duct Opening Protection in Two-hour Fire Walls and Partitions*, Fire Technology, National Fire Protection Association, Quincy, Massachusetts.

<sup>6</sup> Gewain, R. G., B. G. Campbell, J. H. Shanley Jr., J. L. Scheffey, May 1990. *Protection of duct openings in two-hour fire resistant walls and partitions*, ASHRAE JOURNAL, American Society of Heating, Refrigerating and Air-Conditioning Engineers, Inc., Atlanta.

Users of the design criteria found in this Standard are encouraged to utilize the information obtained from the cited research for qualifying ducts for a 2-hour fire-rated exposure when a fire damper is not desirable in a confinement ventilation system. However, when qualifying duct configurations not fire tested by the research, users are cautioned to apply the research results only when applicable designs are supported by engineering calculations performed by qualified engineers competent in the technology.

## Appendix E. Example Glovebox Fire Detection Systems.

This appendix provides examples of detection devices that may be useful for glovebox fire detection systems.

Figure 1 is a wiretype line heat and fire detector. The system uses two, individually encased actuators in a heat sensitive material. The actuators are twisted together to impose a spring pressure between them and then wrapped with a protective tape and finished with an outer covering. A small electric current passes continuously through the lines. At the critical or operating temperature, the heat sensitive jacket yields to the pressure and allows the actuators to contact each other, triggering the alarm.

Figure 2 shows a thermal detector. These may be purchased as fixed-temperature or rate-compensated. Thermal detectors are also available for explosion-proof and weatherproof applications. For glovebox applications, thermal detectors with all-welded stainless steel shells should be used.

Figures 3 and 4 are examples of two design devices used for remote testing of standard, stem-type heat detectors mounted in gloveboxes.

Tests were recently performed for DOE's Rocky Flats Environmental Technology Site to determine what time lag would be experienced as a result of the heater and clamp assembly used for testing the detectors (Figure 3). In the tests, the unmodified, stem-type detector had a response time index (RTI) of 40 and the modified unit (with the heater and clamp) had an RTI of 100. For the modified unit to operate satisfactorily, the installation should be on an 8-foot (2.44-meter) spacing (rather than 11-foot [3.36-meter] spacing as permitted for the unmodified unit). The unit shown in Figure 4 has not been tested.

Figure 5 illustrates a "Well-type" temperature detector. Note that this is not considered a "fire detector" in the conventional sense, although it is credited under certain circumstances with a fire warning capability.

# Appendix E

Line Heat and Fire Detector - Figure 1



Cable is available in continuous lengths to provide for long length of runs.

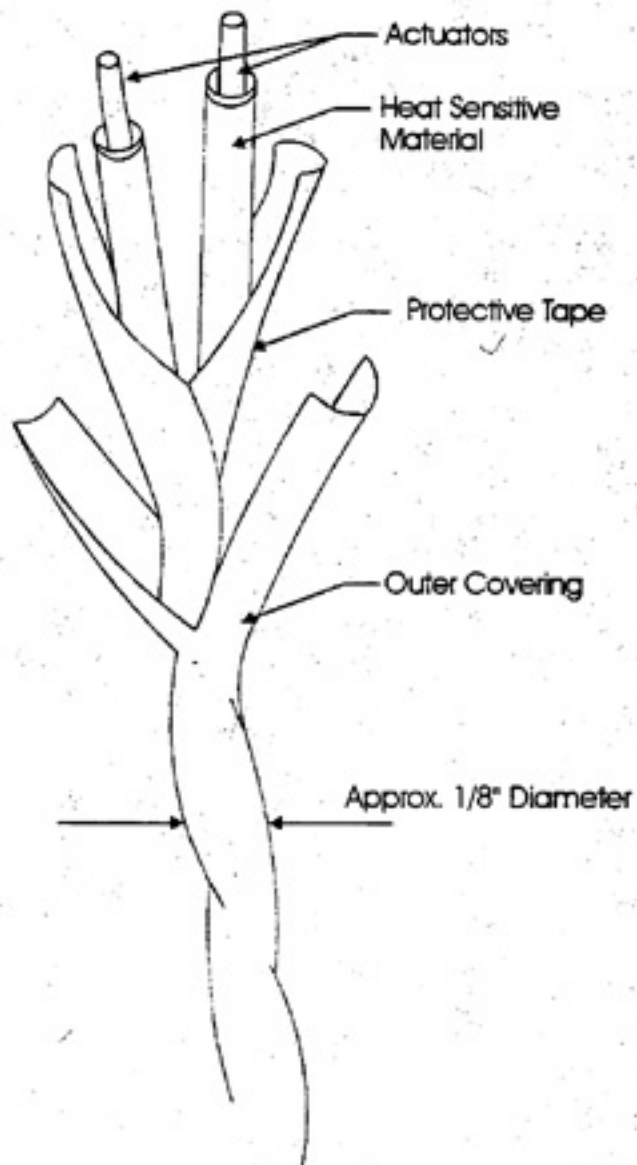

## Application:

There are several manufacturers of heat detector type cables.

Some may be used in aggressive atmospheres and others are designed for use in classified hazardous areas.

# Appendix E

Thermal Fire Detectors - Figure 2

Maximum UL Listed Spacing is 40' x 40'

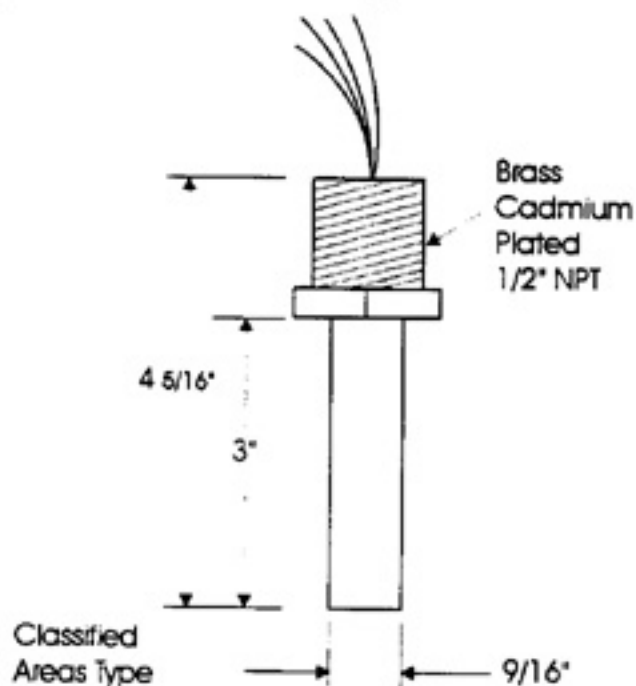

Maximum UL Listed Spacing is 50' x 50'

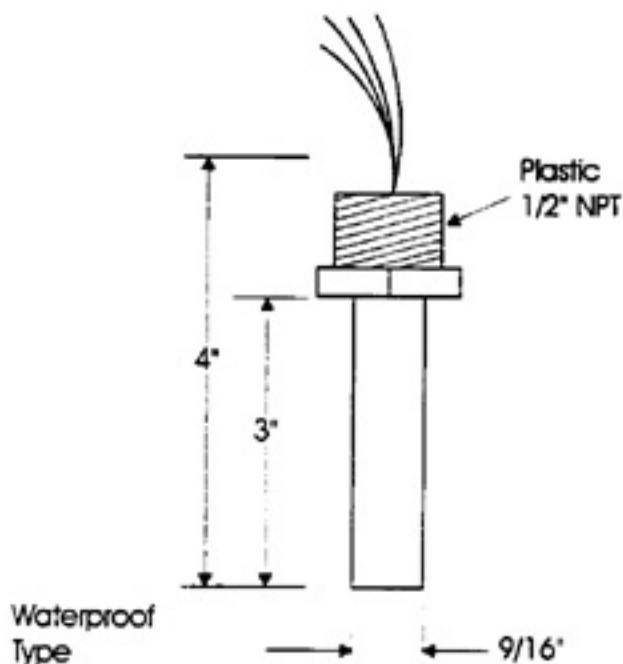

## Thermal Fire Detectors

Waterproof and models designed for classified hazardous areas are available.

The thermal detectors are designed for use with commercially available fire alarm systems. The detector element in all models is self restoring after operation.

The detectors typically can be used with any fire alarm circuit of any manufacture using open circuit direct shorting type units.

The waterproof models are furnished with leads through a plastic 1/2 inch NPT hub that screws into a standard waterproof junction box cover. The shell is epoxy coated and offers strong resistance to corrosive atmospheres.

Classified models are UL listed for class I, groups C and D, class II, groups E, F and G when installed in a listed explosion proof junction box. The classified models should not be installed in outdoor or other wet locations.

# Appendix E

## Remote Testing Unit for Thermal Detectors - Figure 3

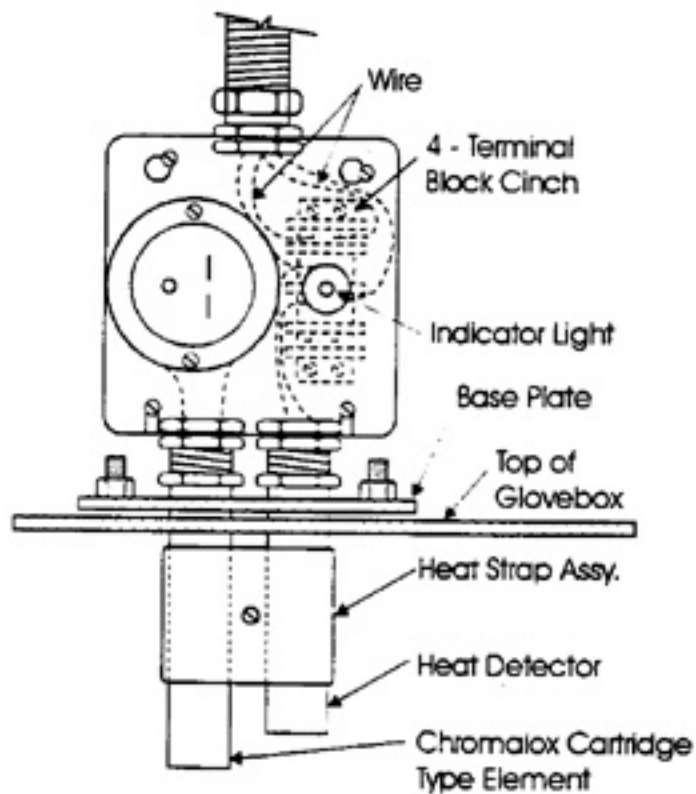

Heat Detector Assembly & Installation

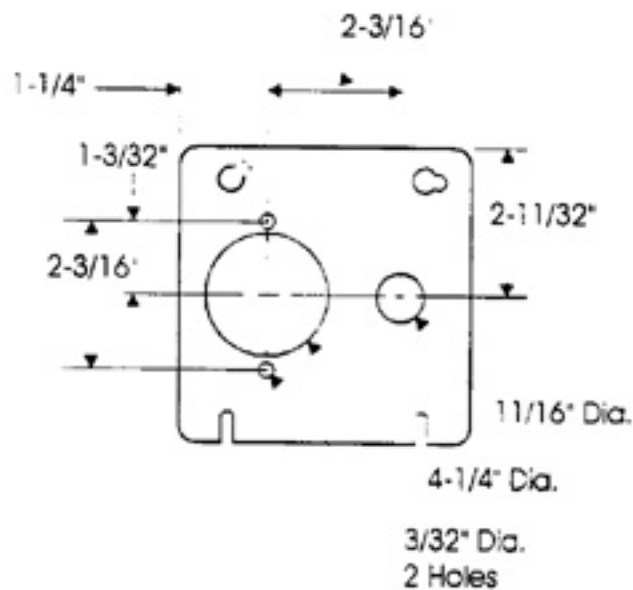

Box Cover Modification

# Appendix E

Remote Testing Unit for Thermal Detectors - Figure 4

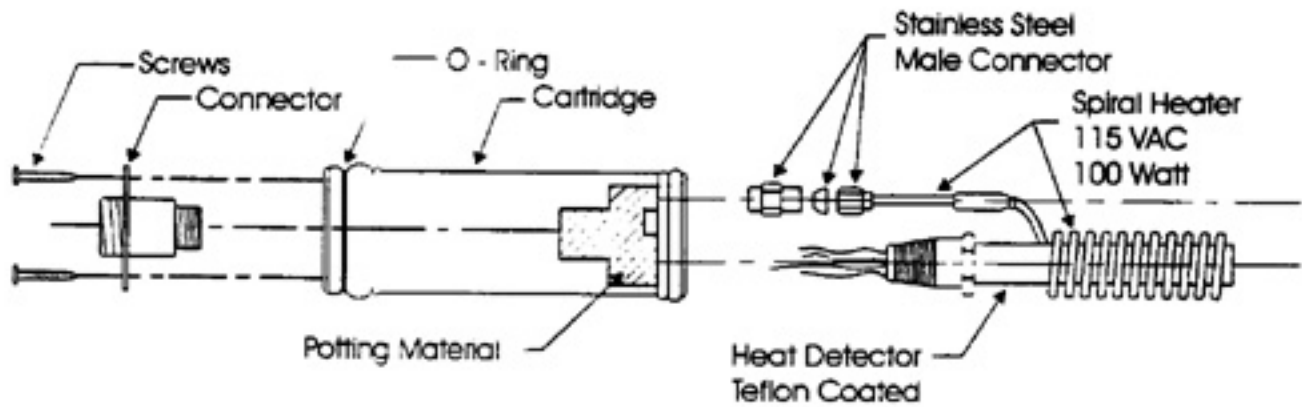

Cartridge Assembly Procedure

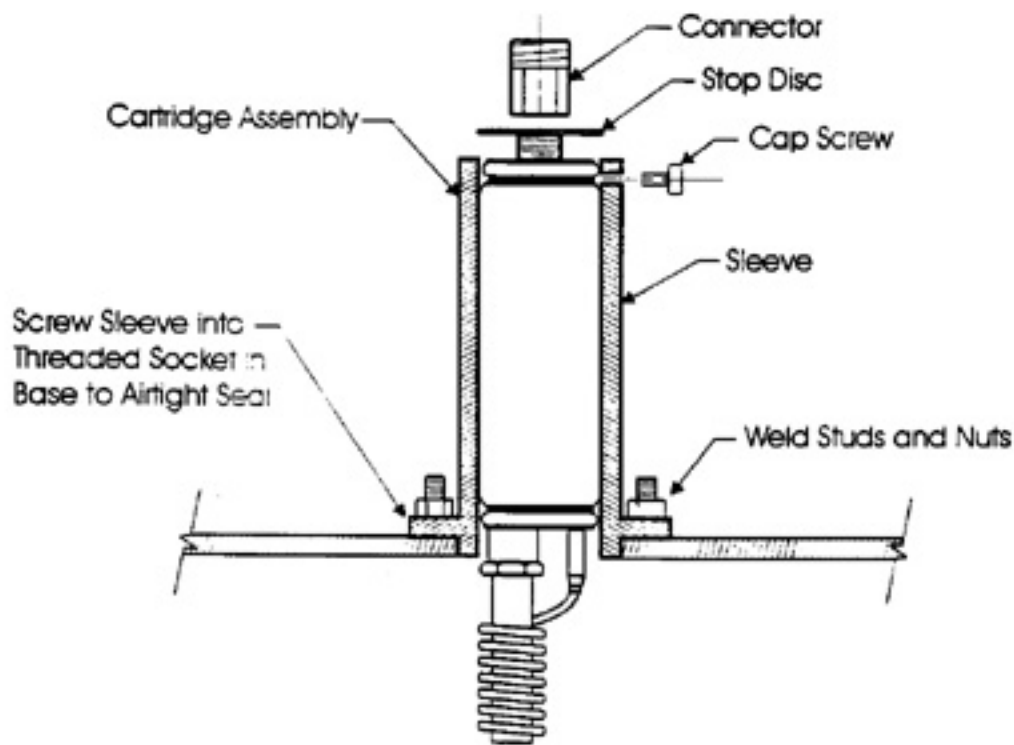

Glove Box Overheat Detector Installation Detail

# Appendix E

Well Type Detector - Figure 5

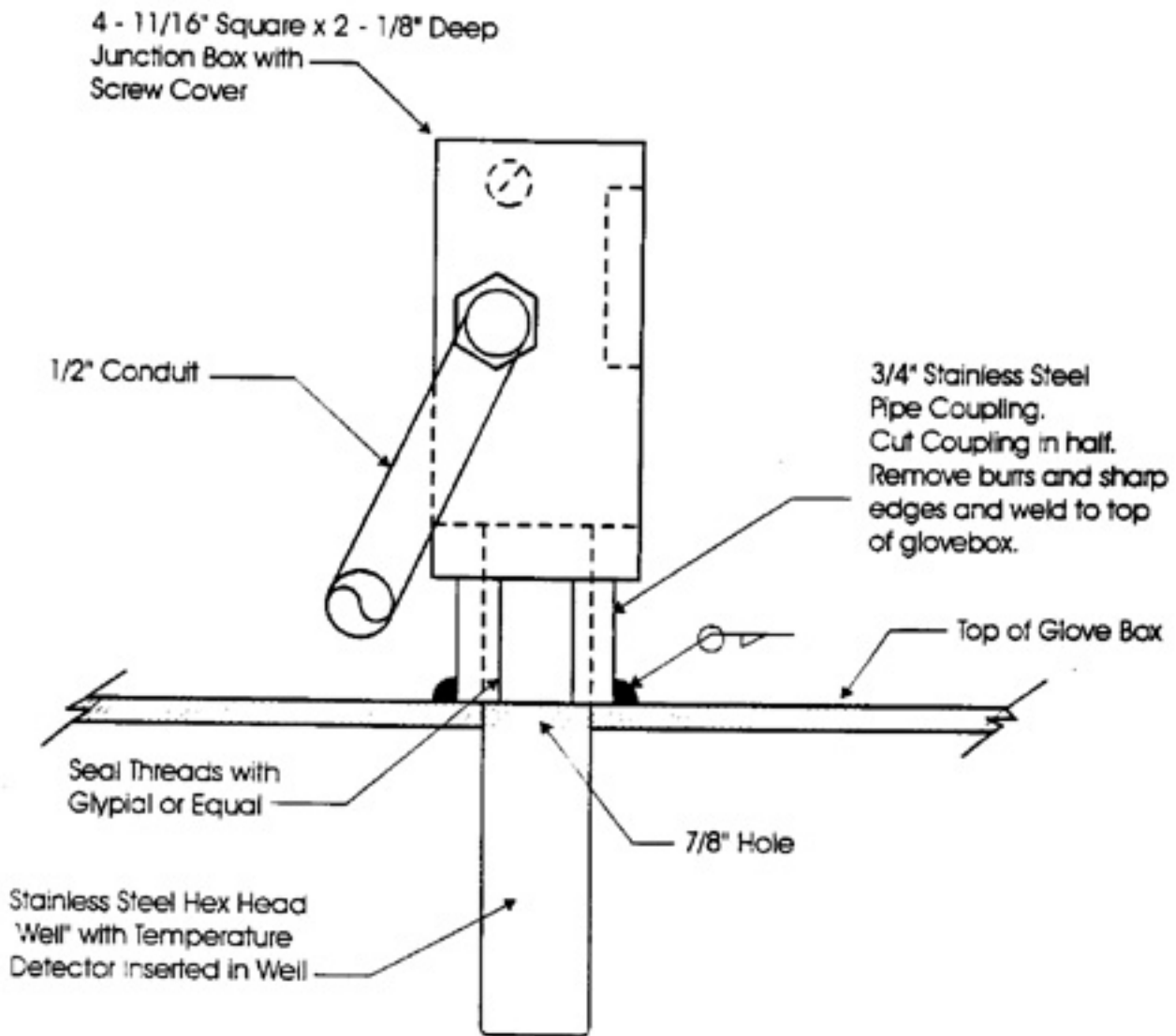



# Appendix F

## Quick Disconnect Coupling

1/4" - 3000 Pound Forged Coupling

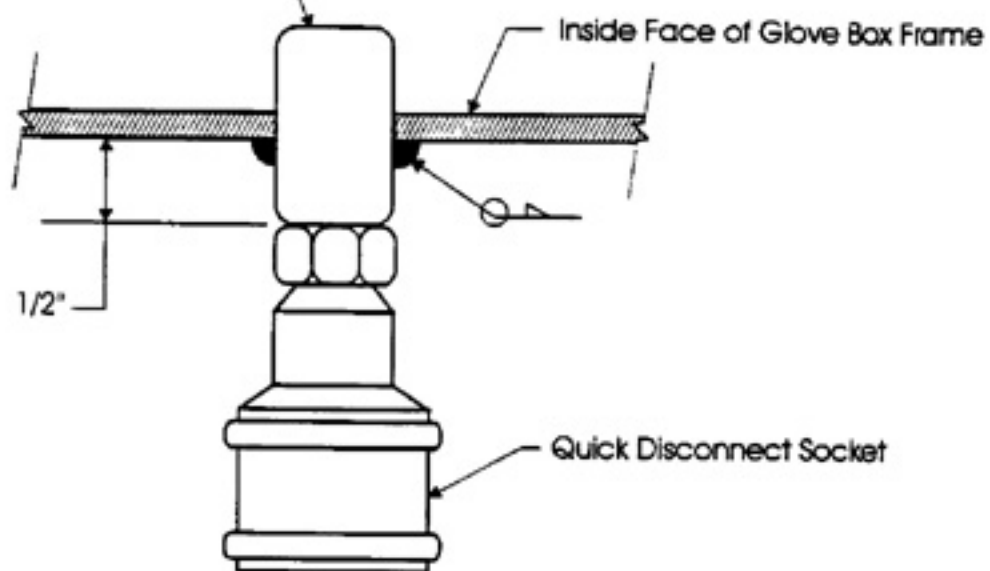

Figure 1

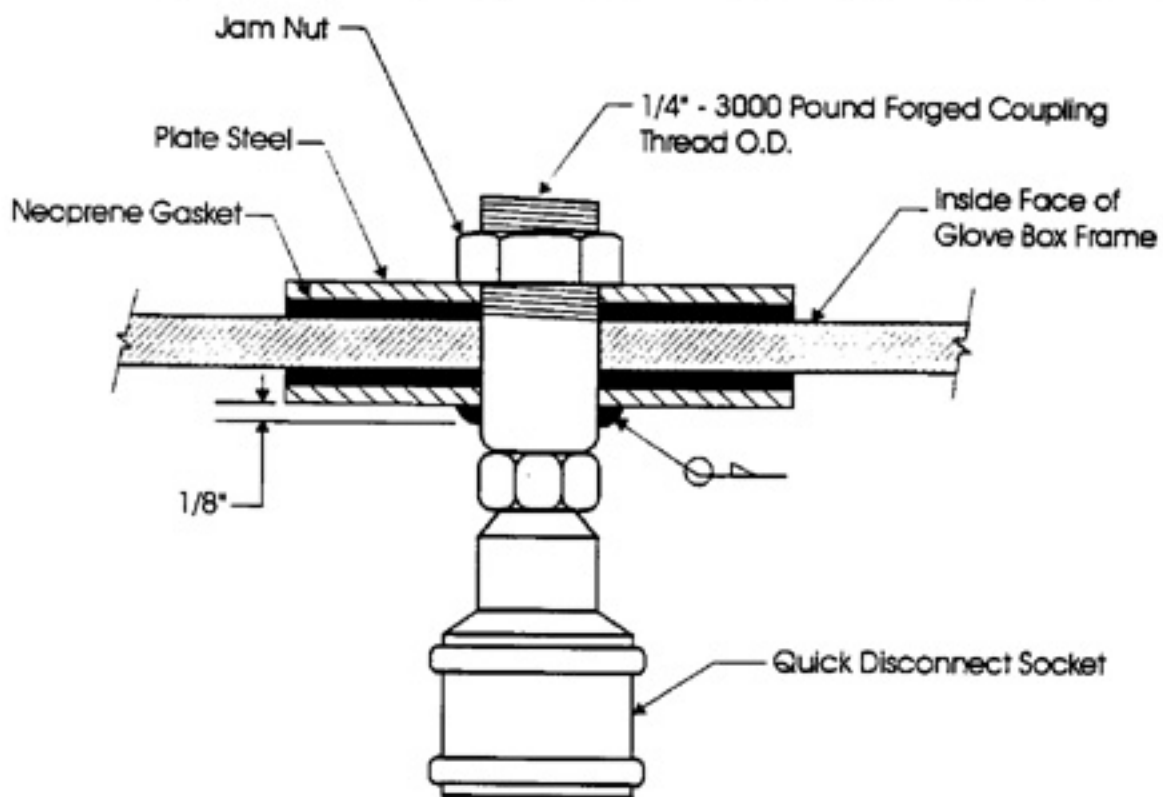
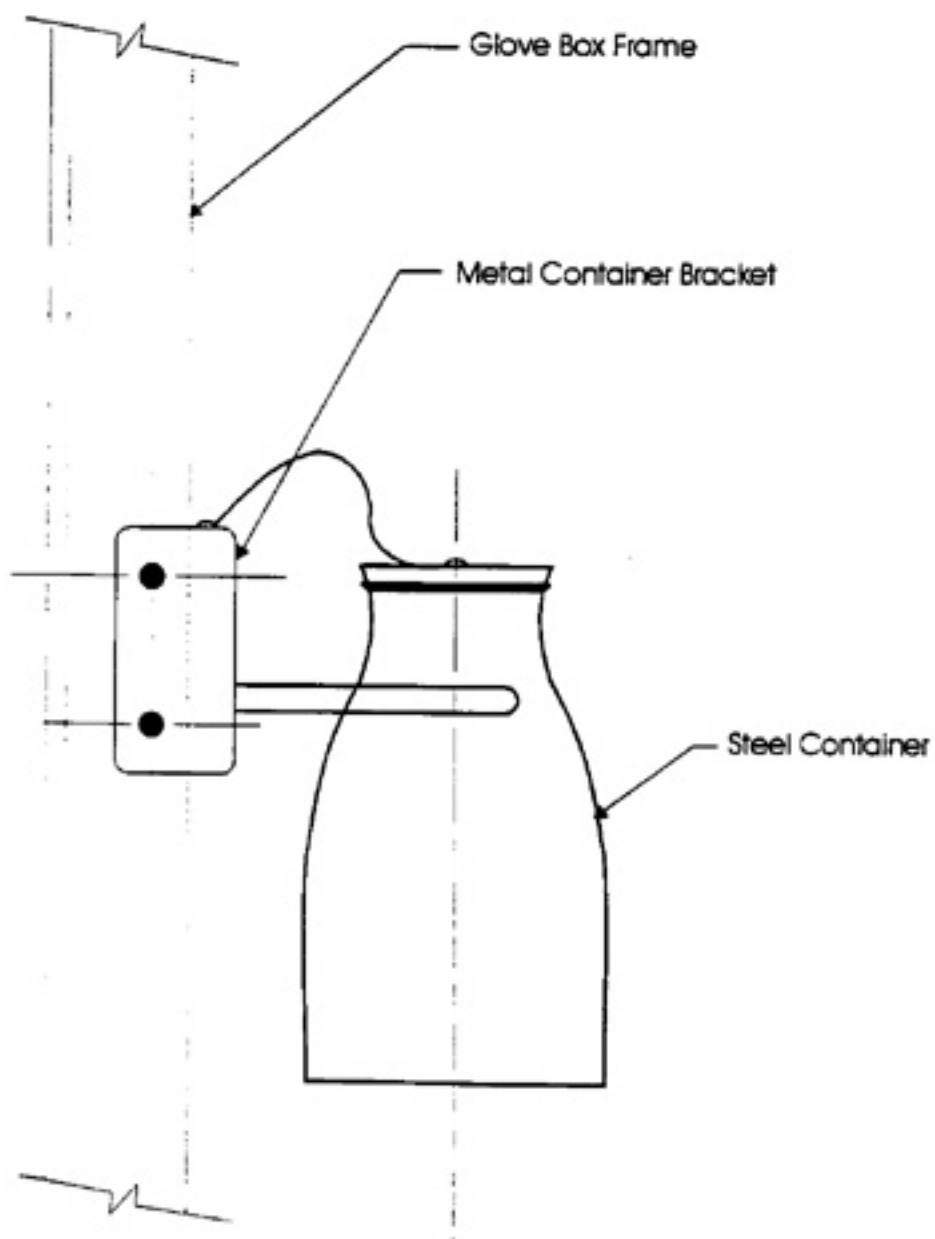

Figure 2

# Appendix G

## Mounting Concept for Container Holding Dry Powder Extinguishing Agent



Primary for Use in Gloveboxes where the  
Potential for Metal Fires Exists

## **Appendix H. Limited Water Sprinkler Design**

This design is one method that may be used to provide limited water supply automatic sprinkler protection for gloveboxes. As an assembly, the design is not "listed" or "approved," but the individual components are all listed for fire protection application. Use of this system should be approved by the DOE AHJ.

The system consists of pressurized-water portable fire extinguishers (with the number varying depending on criticality requirements) piped to a common manifold and then to the discharge point. A low pressure switch activates a fire alarm when the system discharges. Restricted orifice sprinkler heads are used and a fill port is provided for charging the system.

# Appendix H

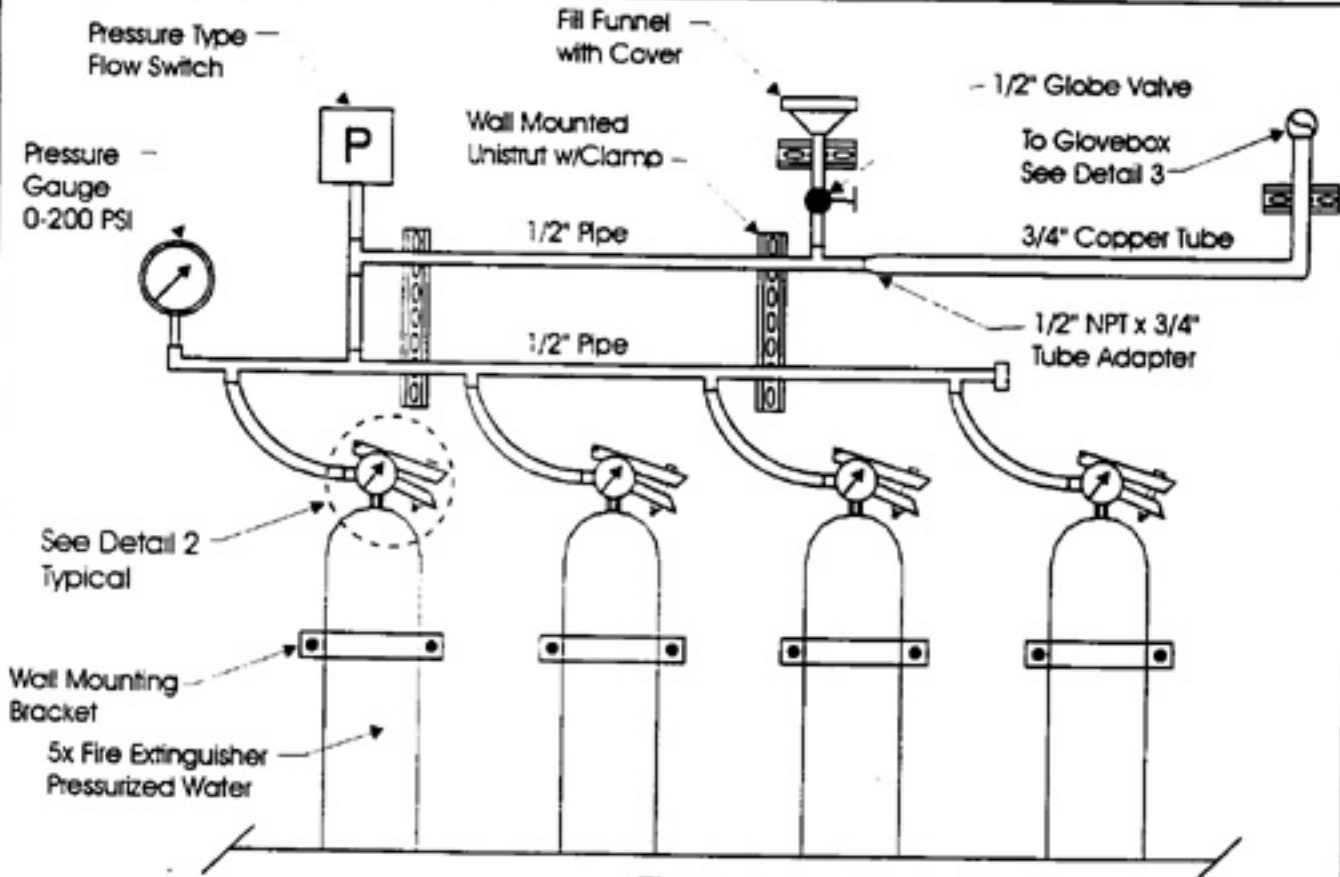

Figure 1  
Elevation - Not to Scale

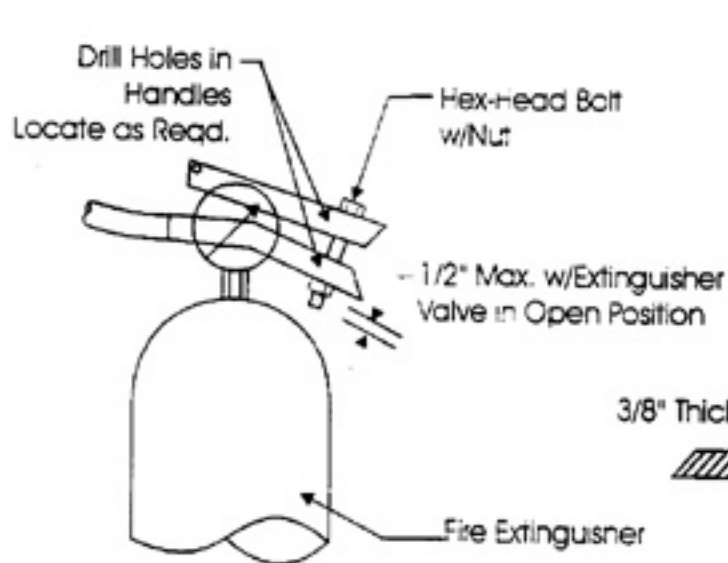

Figure 2  
Not to Scale

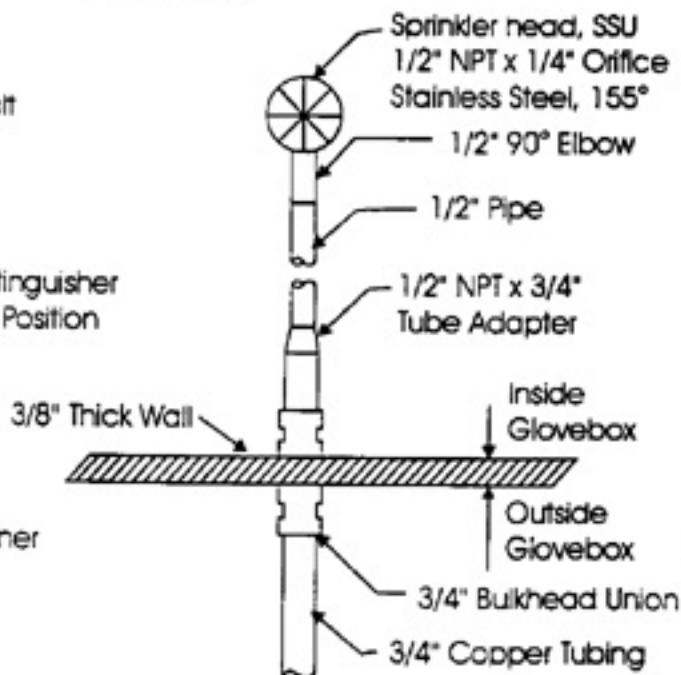

Figure 3  
Plan - Not to Scale

## Appendix I. Glovebox Window Material Comparison

Windows can be the most challenging part of glovebox designs. It is often hard to find a material that satisfies operational requirements and the fire protection and atmosphere compatibility criteria. This chart was developed by Factory Mutual Research Corporation with information from other sources (a few changes were made to the chart such as trade names were relabeled using the material's chemical name). Materials were rated in terms of how well they performed in the areas listed in the left column; materials were judged to be excellent, good, fair, medium, poor, or to have no capability for that criterion. A newer material (developed after these tests), that may be useful as a window material, is fire-rated glass. Note that these are for information purposes only. Window design requirements are provided in Section 4 of this standard.

Testing Areas	Glasses			Plastics			
	Laminated	Tempered	Wired	PMMA <sup>1</sup>	PMMA SE-3	ADC <sup>2</sup>	P.C. <sup>3</sup>
Optics	exc.	exc.	fair	exc.	exc.	exc.	good
Combustibility	exc.	none	none	poor	fair	fair	fair
Heat Resistance	fair	good	exc.	fair	fair	fair	fair
Impact Resistance	fair	good	good	good	good	good	exc.
Chemical Resistance	exc. <sup>4</sup>	exc. <sup>4</sup>	exc. <sup>4</sup>	good	fair	good	good
Radiation Resistance	exc. <sup>5</sup>	exc. <sup>5</sup>	exc. <sup>5</sup>	--	--	--	--
Abrasion Resistance	exc.	exc.	exc.	fair	fair	good	poor
Flexibility	poor	fair	poor	exc.	good	fair	good
Workability	poor	poor	poor	exc.	good	good	good

Testing Areas	Glasses			Plastics			
	Laminated	Tempered	Wired	PMMA <sup>1</sup>	PMMA SE-3	ADC <sup>2</sup>	P.C. <sup>3</sup>
Cost	med.	med.	med.	low	med.	high	high

Notes:

<sup>1</sup> Polymethylmethacrylate

<sup>2</sup> Allyldiglycalcarbonate

<sup>3</sup> Polycarbonate

<sup>4</sup> Except to hydrofluoric acid

<sup>5</sup> If non-browning glass (cerium added)

Wired glass is strongly recommended for all windows, where visibility through the wire layer is tolerable.

Otherwise, laminated safety glass (from sheet or plate stock) is recommended.

Where hydrofluoric acid exposure is serious, where workability of the window material is important, or where the fire hazard is considered not serious, a polycarbonate is recommended.

## **Appendix J. Glovebox Overpressure Protection Valves**

These diagrams demonstrate the basic operating principles of dump/relief valves. These valves may be useful in avoiding glovebox pressurization and maintaining exhaust ventilation. The Rocky Flats Environmental Technology Site has used these valves in their glovebox lines for this purpose.

## Appendix J

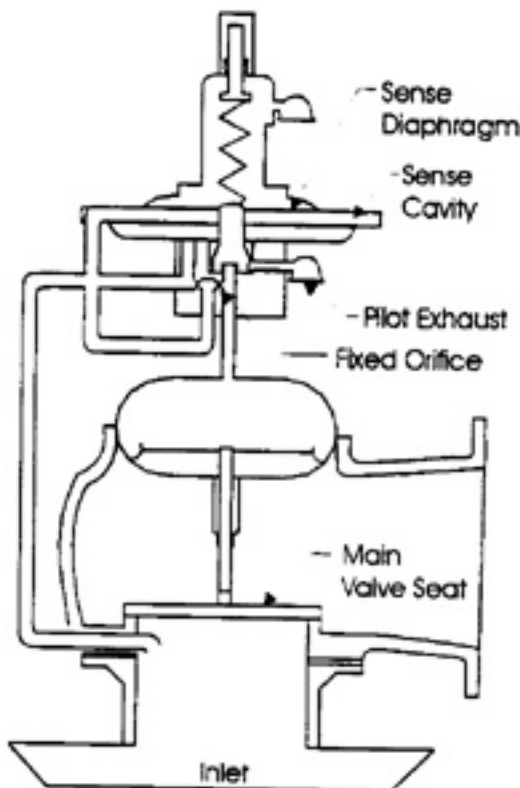

Figure 1  
(Closed)  
Positive Pressure Relief

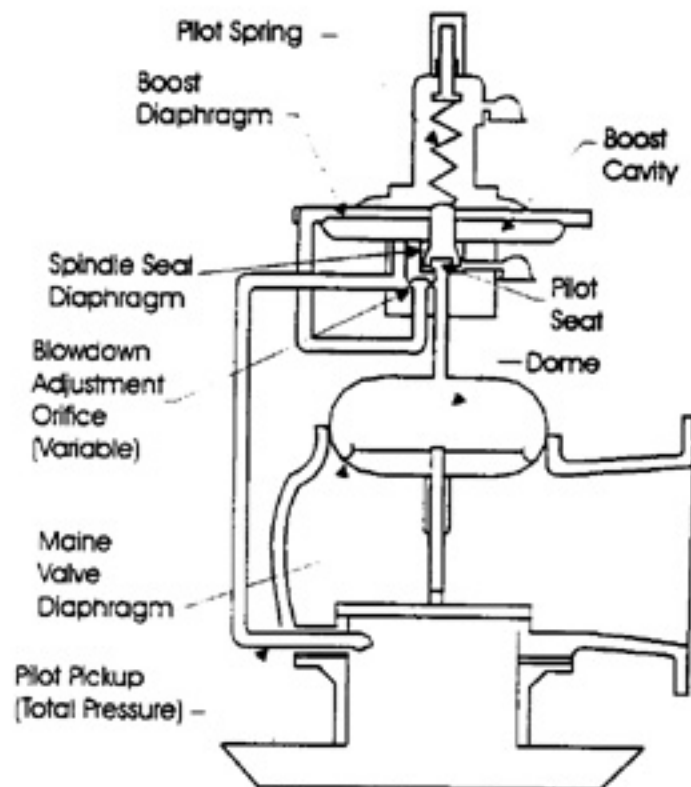

Figure 2  
(Pilot Open)  
Positive Pressure Relief

### Normal Operation of the System is as Follows:

- System pressure acts on the bottom of the main valve seat, on top of the main valve diaphragm, and on the pilot diaphragms. The main valve seat is held tightly closed by a large force, equal to the system pressure times the unbalanced area of the main valve diaphragm.
- System pressure is also applied to the boost cavity and the sense cavity downstream of the variable orifice.
- The soft pilot seat is held closed during the time that the pilot spring load is greater than the upward forces acting on the sense diaphragm.
- When process pressure increases to where the upward force on the sense diaphragm exceeds the spring load, the pilot seat lifts slightly. This initiates a small flow in the pilot sense line.
- The small flow across the blowdown adjustment orifice causes a modest reduction in pressure downstream of the orifice and in the sense cavity.
- This pressure reduction creates a large net upward force that pops the pilot full open (as shown in figure 3).



## Appendix J

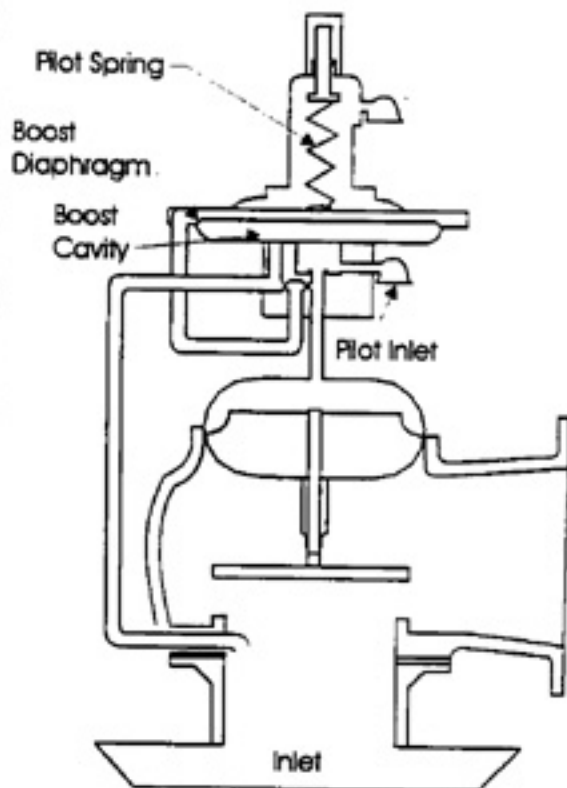

Figure 3  
(Open and Flowing) Positive Pressure Relief

- With the pilot fully open, the main valve seat is fully lifted due to a large reduction in pressure on top of the main valve diaphragm.
- Flow through the main valve continues until system pressure has been reduced enough so the pilot spring is again able to overcome the lifting forces on the sense diaphragm.
- As the pilot begins to close, the flow and pressure drop across the blowdown adjustment orifices decreases.
- The sense cavity pressure then increases to assist in an accelerated closing rate.
- With the pilot closed, full line pressure again loads the dome area and the main valve seat closes. Pressures return to those shown in figure 1.

Note: The point at which the pilot spring overcomes the net lifting forces on the boost diaphragm can be varied by changing the pressure drop across the variable blowdown adjustment orifice. A smaller orifice adjustment makes the valve close at a lower system pressure (lower blowdown).

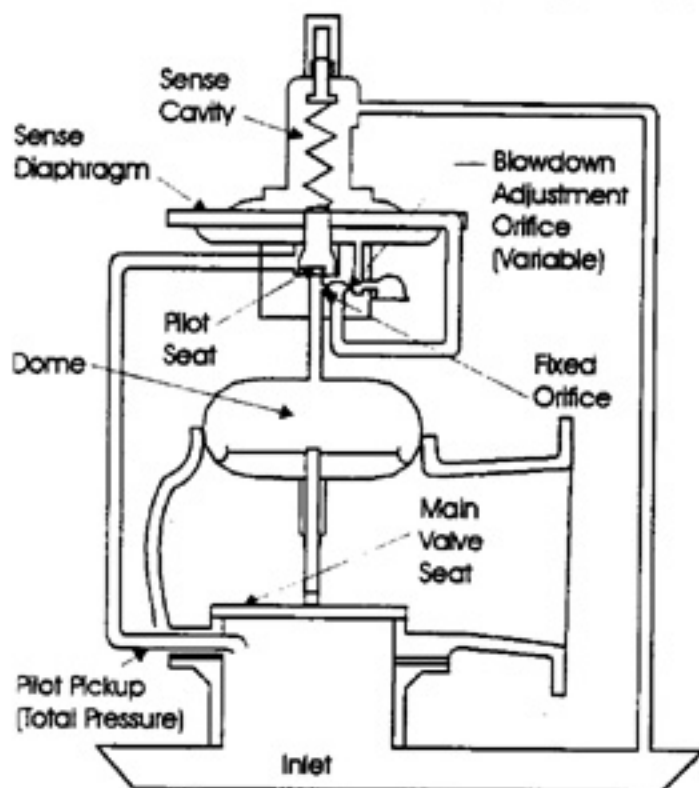

Figure 4  
(Closed) Vacuum Relief

**Vacuum relief operation is basically the same as positive pressure relief operation as follows:**

- A seating force is established by loading the large dome area with a pressure greater than the inlet pressure under the seat.
- In the closed condition, atmospheric pressure is present in the dome area of the main valve and a vacuum is present at the inlet. This causes a net force that closes the seat.
- At set point, the valve opens, discharging the dome pressure through the supply tube into the inlet vacuum.
- With a partial vacuum established in the dome, atmospheric pressure forces the diaphragm and seat open and establishes air flow into the valve. This relieves the system vacuum.
- When the pilot reseats, the supply line is closed by the pilot seat.
- Atmospheric pressure again fills the dome through the blowdown adjustment and fixed orifice, which closes the main valve.

### Appendix K. Glovebox Fire Protection Survey

This table shows the results of a survey taken of various DOE sites to determine where gloveboxes were in use and what type of fire protection was provided.

Site	Glovebox Use	Window Material	Fire Prot.(in box)
Inhalation Toxicology Research Institute	Radiological and toxicological	Glass and polycarbonate	Some with halon
Pantex Plant	Pu, lasers and explosive components	Polycarbonate	N <sub>2</sub> purge
Mound Plant	Tritium, Pu, and U	Safety plate glass, a few with polycarbonate	Tritium- N <sub>2</sub> purge Pu & U- halon
Kansas City Plant	Calcium chloride?	Don't know	N <sub>2</sub> purge, but not installed for fire protection.
Los Alamos National Laboratory	Pu and chemical	Wire glass and safety glass	Pu-inert, dry air & A.S. or detection. Chemical- A.S.
Pinellas Plant	Radiological	Polycarbonate	No protection
Sandia National Laboratories, Albuquerque	Radiological and chemical	Not sure	No protection
Sandia National Laboratories, Livermore	Tritium and U	Glass	Tritium- purge during experiment, H.D. U- no protection
Uranium Mill Tailings Remedial Action Site	None	NA	NA
Waste Isolation Pilot Plant	Freon decon unit (mobile)	Plastic	No protection
Rocky Flats Environmental Technology Site	Pu, beryllium, Pu waste and low-level waste material	Lead glass, wire glass & some polycarbonate	Pu- N <sub>2</sub> /Ar purge, H.D. beryllium- H.D. Pu waste- dry chemical Low-level waste mater.- A.S.
AMES Laboratory	Pu and chemical	Wire glass, PMMA <sup>1</sup>	No protection
Argonne National Laboratory-East	Radiological and chemical	Plastic	CO <sub>2</sub>

Site	Glovebox Use	Window Material	Fire Prot.(in box)
Argonne National Laboratory-West	Pu, radiological and waste characterization	Safety glass & plastic	Pu- Ar purge others- H.D.
Brookhaven National Laboratory	Low radiological and biological	Glass and polycarbonate	No protection
Environmental Measurements Laboratory	Chemical/toxicological (box made of fiberglass)	Safety glass	No protection
Fermi National Accelerator Laboratory	Lithium, no longer in use.	NA	N <sub>2</sub> purge when operating.
Massachusetts Institute of Technology	Chemical, pyrophoric materials and biological	Polycarbonate, PMMA & safety glass	Pyrophoric mater.- Ar or N <sub>2</sub> purge  Others- no protection
Ohio University	None	NA	NA
Princeton Plasma Physics Laboratory	Sandblasting (very small, portable)	Plastic	No protection
Rensselaer Polytech. Institute	Biological	Polycarbonate	No protection
Solar Energy Research Institute	Lithium and sodium	Plastic	Ar-purge
University of Notre dame	Chemical	Plastic	N <sub>2</sub> -purge
University of Utah	Radiological	Plastic	No protection
Washington University	Chemical	Safety glass	Ar or N <sub>2</sub> purge
Yale University	Radiological	Not sure	No protection
Morgantown Energy Technology Center	Toxic chemicals	Plastic	No protection
Pittsburgh Energy Technology Center	Chemical and toxicological	Not sure	No protection
EG&G-Idaho	None	NA	NA
MSE, Inc.	None	NA	NA
Rockwell-Idaho	None	NA	NA
Westinghouse-Idaho	U	Glass and plastic	H.D.
West Valley Demonstration Project	Radiological and chemical	Not sure-probably glass	No protection

Site	Glovebox Use	Window Material	Fire Prot.(in box)
UNC Geotech	None	NA	NA
WEC Bettis Atomic Power Laboratory	Radiological, chemical, and U	Lead glass	CO <sub>2</sub>
Portsmouth Gaseous Diffusion Plant	U oxide and U hexafluoride	Polycarbonate and PMMA	No protection
K-25, Oak Ridge	None	NA	NA
Oak Ridge National Laboratory	Radiological and chemical	Glass and PMMA	A.S. (limited water)
Paducah Gaseous Diffusion Plant	Radiological and chemical (not in use)	Plastic?	No protection
Y-12, Oak Ridge	U, lithium, and beryllium	Polycarbonate & PMMA	U- Ar purge, H.D. active. Lithium/beryll.- N <sub>2</sub> purge  NOTE: 1 classified box has A.S. with a purge.
Fernald Environmental Management Project	None	NA	NA
Reynolds	None	NA	NA
GE-Vallecitos	None	NA	NA
Rockwell - Canoga Park, CA	Chemical	PMMA	No protection
Stanford	None	NA	NA
Berkeley	Radiological	PMMA & lead glass (boxes are made of plywood or fiberglass)	No protection
LLNL	Radiological and biomedical	Wire glass, safety glass & polycarbonate	Radiological- inert some with H.D.
University of CA. (LA.)	Tritium carcinogens	Plastic	No protection
University of CA. (SAN.)	Ionization	Lead glass	No protection
Savannah River Site	Radiological and a few biological	Fire-rated glass & PMMA	Halon

Site	Glovebox Use	Window Material	Fire Prot.(in box)
Hanford Site	Pu, Pu Waste, U, chemical, and neptunium	Polycarbonate, wire glass, safety glass, PMMA	Pu- MgO <sub>2</sub> sand, halon Pu waste- A.S. (limited water) or dry chemical Neptunium- H.D. U- H.D. or halon chemical- A.S.(limited water) or H.D.

<sup>1</sup> Polymethalmethacrylate

NOTE: When halon is discharged in gloveboxes with combustible metals such as plutonium, the halon is not intended to extinguish a metal fire but rather to extinguish or prevent ignition of adjacent combustible materials that may also be present.

## Appendix L. References

### Filter Plenum References

Alvares, N., D. Beason, V. Bergman, J. Creighton, H. Ford, and A. Lipska. 1980. *Fire Protection Countermeasures for Containment Ventilation*, UCID-1878, Lawrence Livermore National Laboratory, Livermore, California.

American Society of Heating, Refrigeration and Air-Conditioning Engineers, Inc., 1988 *ASHRAE Handbook Equipment*, Atlanta, 1988.

American Society of Heating, Refrigeration and Air-Conditioning Engineers, Inc., 1991 *ASHRAE Handbook Heating, Ventilation and Air-Conditioning Applications*, Atlanta, 1991.

ANSI N304-1986, *American National Standard for Nuclear Fuel Facilities - Facilities for Reprocessing Fuel - Fire Protection*, American National Standards Institute, Inc., 1986.

ASME N510, *Testing of Nuclear Air Treatment Systems*, The American Society of Mechanical Engineers, New York, 1989.

Bergman, W. G. Larson, R. Lopez, K. Williams, and C. Violet, *High Efficiency Steel Filters for Nuclear Air Cleaning*, Proc. 21th DOE/NRC Nuclear Air Cleaning Conference, Boston, August 22-25, 1989.

Burchsted, C.A., J.E. Kahn and A.B. Fuller. 1976. *Nuclear Air Cleaning Handbook*, EDRA 76-21. Oak Ridge National Laboratory. Oak Ridge, Tennessee.

Campbell, B.G., *Fire Protection for Filter Plenums at a Nuclear Facility*, International Fire Protection Engineering Institute, May 30, 1989.

Carbaugh, E.H., *Survey of HEPA Filter Applications and Experiences at Department of Energy Sites*, Pacific Northwest Laboratory, Richland, November 1981.

Cartwright, D.R., C.M. Johnson, M.A. Thompson, *Filter Plenum Fire Tests*, The Dow Chemical Company Rocky Flats Division, Golden, Colorado, September 3, 1970.

DOE Order 5480.7, *Fire Protection*, U.S. Department of Energy, Washington, D.C., Rev. November 1987.

DOE Order 5480.7A, *Fire Protection*, U.S. Department of Energy, Washington, D.C., Rev. Dec 1992.

DOE Order 6430.1A, *General Design Criteria*, U.S. Department of Energy, Washington, D.C., April 1989.

Domning, W.E., *New Fire Protection Systems for Filter Plenums*, 11th Proc. AEC Air Cleaning Conference, Richland, August 31-September 3, 1970.

Factory Mutual Research Corporation, *Approval Guide 1991*, Boston, 1991.

Fluor Daniel, *A Conceptual Study of Metal Fiber Filters for Nuclear Air Cleaning in the HWVP*, U.S. Department of Energy, Richland, January 1991.

Gaskill, J.R. and M.W. Magee, *The HEPA-Filter Smoke Plugging Problem*, Proc. 13th AEC Air Cleaning Conference, San Francisco, August 12-15, 1974.

Gewain, R. G., B. G. Campbell, J. H. Shanley Jr., J. L. Scheffey, May 1990. *Protection of duct openings in two-hour fire resistant walls and partitions*, ASHRAE JOURNAL, American Society of Heating, Refrigerating and Air-Conditioning Engineers, Inc., Atlanta.

Gewain, R., J. Shanley, P. DiNunno, J. Scheffey, B. Campbell. August 1991. *Evaluation of Duct Opening Protection in Two-hour Fire Walls and Partitions*, Fire Technology, National Fire Protection Association, Quincy, Massachusetts.

Gregory, W.S., R.A. Martin, P.R. Smith, and D.E. Fenton, *Response of HEPA Filters to Simulated Accident Conditions*, Proc. 17th DOE Air Cleaning Conference, Denver, August 2-5, 1982.

Hackney, S., *Fire Testing of HEPA Filters Installed in Filter Housings*, Proc. 17th DOE Air Cleaning Conference, Denver, August 2-5, 1982.

Hill, A.J., *Fire Prevention and Protection in Hot Cells and Canyons*, DP-1242, Savannah River Laboratory, Aiken, South Carolina, April 1977, pg 12.

Holmes, W.D., *A Current Evaluation of Fire Loss Control Systems for Charcoal Media*, Proc. 19th DOE/NRC Nuclear Air Cleaning Conference, Seattle, August 17-21, 1986.

Kovach, J.L., *Review of Fire and Fire Control Methods for Nuclear Air Cleaning Systems*, Proc. 19th DOE/NRC Nuclear Air Cleaning Conference, Seattle, August 17-21, 1986.

Lee, H.A., *Final Report - Program for Fire Protection, Caves, Canyons, and Hot Cells*, ARH-ST-104, Atlantic Richfield Hanford Company, Richland, August 1974.

Lee, H.A., *Guide to Fire Protection in Caves, Canyons, and Hot Cells*, ARH-3020, Atlantic Richfield Hanford Company, Richland, July 1974.

Mathewes, W., *Conclusions from Fire Tests in Activated Carbon Filled Adsorbers*, Proc. 19th DOE/NRC Nuclear Air Cleaning Conference, Seattle, Washington, August 17-21, 1986.

NFPA 69, *Explosion Prevention Systems*, National Fire Protection Association, Vol 2, Boston, 1986.

NFPA 90A, *Installation of Air Conditioning and Ventilation Systems*, National Fire Protection Association, Vol 4, Boston, 1989.

NFPA 90B, *Warm Air Heating and Air Conditioning Systems*, National Fire Protection Association, Vol 4, Boston, 1989.

NFPA 91, *Blower and Exhaust Systems for Dust, Stock, and Vapor Removal or Conveying*, National Fire Protection Association, Vol 4, Boston, 1990.

NFPA 801, *Facilities Handling Radioactive Materials*, National Fire Protection Association, Vol 11, Boston, 1991.

NFPA 803, *Fire Protection for Light Water Nuclear Power Plants*, National Fire Protection Association, Vol 7, Boston, 1988.

Nuclear Standard NE F3-43, *Quality Assurance Testing of HEPA Filters*, U.S. Department of Energy, Oak Ridge, Tennessee, February 1990.

Nuclear Standard NE F3-45, *Specifications for HEPA Filters Used By DOE Contractors*, U.S. Department of Energy, Oak Ridge, Tennessee, October 1988.

Regulatory Guide 3.12, *General Design Guide for Ventilation Systems of Plutonium and Fuel Fabrication Plants*, U.S. Atomic Energy Commission, Washington, D.C., 1973.

Regulatory Guide 3.32, *General Design Guide for Ventilation Systems for Fuel Reprocessing Plants*, U.S. Atomic Energy Commission, Washington, D.C., 1975.

Rockwell Hanford Operations Specification Number HWS 10278 Rev A000, *Gaseous Effluent HEPA Filter System, In-Place Efficiency Testing of*, Rockwell International, June 1981.

Rocky Flats Plant Standard No. SE-804, *Standard for Deluge Fire Suppression Control System*, Rockwell International, September 1988.

Rocky Flats Plant Standard No. SE-805, *Standard for GloveBox Overheat Detector Assembly (Push Through Type)*, Rockwell International, August 11, 1989.

Rocky Flats Plant Standard No. SF-100, *Fire Protection Standards*, Rockwell International, Rev. October 17, 1988.

Rüdinger, V., C.I. Ricketts, and J.G. Wilhelm, *High-Strength High-Efficiency Particulate Air Filters for Nuclear Applications*, Nuclear Technology, Vol. 92, pp. 11-29 (October 1990).

Savornin, J., *Means Used to Make Sure That the Confinement is Maintained in Case of Fire* Proc. 19th DOE/NRC Nuclear Air Cleaning Conference, Seattle, Washington, August 17-21, 1986.

Scowen, P.A., *Still No Consensus On Containment Filter Venting*, Nuclear Engineering International, February 1989.

UBC 1988, *Uniform Building Code*, International Conference of Building Officials, Whittier, California, 1988.

Underwriters Laboratories, Inc., *Building Materials Directory*, Northbrook, Illinois, 1991.

Underwriters Laboratories, Inc., *Fire Protection Equipment Directory*, Northbrook, Illinois, 1991.

### **Glovebox References**

C. A. Burchsted, J. E. Kahn, and A. B. Fuller. *Nuclear Air Cleaning Handbook*. ERDA 76-21. Oak Ridge, Tennessee. March 1976.

Factory Mutual Research Corporation. *Glovebox Fire Safety*. Norwood, Massachusetts. 1967.

J. D. Rapoza and F. E. Corning. *Glovebox Fire Tests Using Pyrophoric Metal*. Atomics International. Report No. AI-65-MEMO-209. October 1965.

National Fire Protection Association. NFPA 801, *Recommended Fire Protection Practices for Facilities Handling Radioactive Materials*. Quincy, Massachusetts. 1991 Edition.

Rocky Flats Plant Standard No. SE-802. *Standard for Glovebox Overheat Detector Assembly (Self-Contained Testing)*. September 1990



Rocky Flats Plant Standard No. SE-805. *Standard for Glovebox Overheat Detector Assembly (Push-Through Type)*. August 1989.

R. R. King Jr. *Interim Report on the Glovebox Fire Control Studies*. General Electric Company, (HW-67074). Richland, Washington. October 1960.

U.S. Atomic Energy Commission. Regulatory Guide 3.12. August 1973.

U.S. Department of Energy. DOE 6430.1A, *General Design Criteria*. April 1989.

W. E. Domning and R. W. Woodard. *Glovebox Fire Tests*. The Dow Chemical Company. Golden, Colorado. November 1970.

## Appendix M. Concluding Material

### Review Activity:

DOE

DP

EE

EH

EM

NE

NN

ER

Field Offices

AL

CH

GO

ID

NV

OR

RL

SF

SR

Fernald

### Preparing Activity:

DOE-EH-51

**Project Number:**

**GDRQ 0008**

### National Laboratories

BNL

LLNL

LANL

NREL

PNL

Sandia

### Area Offices

Amarillo Area Office

Kirtland Area Office

Princeton Area Office

Rocky Flats Area Office

1. Document Number	2. Document Title		
3. Name of Submitting Organization		4. Type of Organization (Mark one)	
		<input type="checkbox"/> Vendor <input type="checkbox"/> User <input type="checkbox"/> Manufacturer <input type="checkbox"/> Other (Specify) _____	
5. Problem Areas (Attach extra sheets as needed.)			
a. Paragraph Number and Wording			
b. Recommended Wording			
c. Reason/Rationale for Recommendation			
6. Remarks			
7a. Name of Submitter (Last, First, Mi)		7b. Work Telephone Number (Include Area Code)	
7c. Mailing Address (Street, City, Zip Code)		8. Date of Submission	

INSTRUCTIONS: In a continuing effort to improve the U.S. Department of Energy (DOE) Technical Standards, this form is provided for use in submitting comments and suggestions for

improvements. All users of DOE Technical Standards are invited to provide suggestions. This form may be detached, folded along the lines indicated, taped along the loose edge (DO NOT STAPLE) and mailed to the address indicated or faxed to (615) 574-0382.

1. The submitter of this form must complete blocks 1 through 8.
2. The Technical Standards Program Office (TSPO) will forward this form to the Preparing Activity. The Preparing Activity will reply to the submitter within 30 calendar days of receipt from the TSPO.

NOTE: This form may not be used to request copies of documents, nor to request waivers, deviations, or clarification of specification requirements on current contractors. Comments submitted on this form do not constitute or imply authorization to waive any portion of the referenced document(s) or to amend contractual requirements.

#### **OMB Burden Disclosure Statement**

Public reporting burden for this collection of information is estimated to average 30 minutes per response, including the time for reviewing instructions, searching existing data sources, gathering and maintaining the data needed, and completing and reviewing the collection of information. Send comments regarding this burden estimate or any other aspect of this collection of information, including suggestions for reducing this burden, to Office of Information Resources Management Policy, Plans and Oversight, Records Management Division, HR-422 - GTN, Paperwork Reduction Project (1910-0900), U.S. Department of Energy, 1000 Independence Avenue, S.W., Washington DC 20585; and to the Office of Management and Budget (OMB) Paperwork Reduction Project (1910-0900), Washington, DC 20503.

---

U.S. Department of Energy Technical Standards Program Office  
c/o Performance Assurance Project Office  
P.O. Box 2009, Bldg. 9201-3  
Oak Ridge, Tennessee 37831-8065