

## HIGHLIGHTS OF PRESCRIBING INFORMATION

These highlights do not include all the information needed to use VENTOLIN HFA Inhalation Aerosol safely and effectively. See full prescribing information for VENTOLIN HFA Inhalation Aerosol.

**VENTOLIN® HFA (albuterol sulfate) Inhalation Aerosol**  
Initial U.S. Approval: 1981

### RECENT MAJOR CHANGES

Pediatric Use (8.4) 3/2008

### INDICATIONS AND USAGE

VENTOLIN HFA is a beta<sub>2</sub>-adrenergic agonist indicated for:

- Treatment or prevention of bronchospasm in patients 4 years of age and older with reversible obstructive airway disease (1.1)
- Prevention of exercise-induced bronchospasm in patients 4 years of age and older. (1.2)

### DOSAGE AND ADMINISTRATION

FOR ORAL INHALATION ONLY.

- Treatment or prevention of bronchospasm in adults and children 4 years of age and older: 2 inhalations every 4 to 6 hours. For some patients, 1 inhalation every 4 hours may be sufficient. (2.1)
- Prevention of exercise-induced bronchospasm in adults and children 4 years of age and older: 2 inhalations 15 to 30 minutes before exercise. (2.2)
- Priming information: Prime VENTOLIN HFA before using for the first time, when the inhaler has not been used for more than 2 weeks, or when the inhaler has been dropped. To prime VENTOLIN HFA, release 4 sprays into the air away from the face, shaking well before each spray. (2.3)
- Cleaning information: At least once a week, wash the actuator with warm water and let it air-dry completely. (2.3)

### DOSAGE FORMS AND STRENGTHS

Inhalation aerosol: 108 mcg albuterol sulfate (90 mcg albuterol base) from mouthpiece per actuation. Supplied in 18-g canister containing 200 actuations. (3)

### CONTRAINDICATIONS

Hypersensitivity to albuterol sulfate or any of the ingredients of VENTOLIN HFA. (4)

### WARNINGS AND PRECAUTIONS

- Paradoxical bronchospasm may occur and should be treated immediately with alternative therapy. (5.1)
- Need for more doses of VENTOLIN HFA than usual may be a sign of deterioration of asthma and requires reevaluation of treatment. (5.2)
- Cardiovascular effects may occur with beta-adrenergic agonists use. Consider discontinuation of VENTOLIN HFA if these effects occur. Use with caution in patients with underlying cardiovascular disorders. (5.4)
- Immediate hypersensitivity reactions may occur. Discontinue VENTOLIN HFA if immediate hypersensitivity reactions occur. (5.6)

### ADVERSE REACTIONS

Most common adverse reactions (incidence ≥3%) are throat irritation, viral respiratory infections, upper respiratory inflammation, cough, and musculoskeletal pain. (6)

To report SUSPECTED ADVERSE REACTIONS, contact GlaxoSmithKline at 1-888-825-5249 or FDA at 1-800-FDA-1088 or [www.fda.gov/medwatch](http://www.fda.gov/medwatch).

### DRUG INTERACTIONS

- Beta-blockers: May block bronchodilatory effects of beta-agonists and produce severe bronchospasm. Patients with asthma should not normally be treated with beta-blockers. (7.1)
- Diuretics: Electrocardiographic changes and/or hypokalemia associated with diuretics may worsen with concomitant beta-agonists. Consider monitoring potassium levels. (7.2)
- Monoamine oxidase inhibitors (MAOs) or tricyclic antidepressants: May potentiate effect of albuterol on the vascular system. Consider alternative therapy in patients taking MAOs or tricyclic antidepressants. (7.4)

See 17 for PATIENT COUNSELING INFORMATION and FDA-approved patient labeling.

Revised: March 2008  
VNT:2PI

**FULL PRESCRIBING INFORMATION: CONTENTS\***

**1 INDICATIONS AND USAGE**

- 1.1 Bronchospasm
- 1.2 Exercise-Induced Bronchospasm

**2 DOSAGE AND ADMINISTRATION**

- 2.1 Bronchospasm
- 2.2 Exercise-Induced Bronchospasm
- 2.3 Administration Information

**3 DOSAGE FORMS AND STRENGTHS**

**4 CONTRAINDICATIONS**

**5 WARNINGS AND PRECAUTIONS**

- 5.1 Paradoxical Bronchospasm
- 5.2 Deterioration of Asthma
- 5.3 Use of Anti-Inflammatory Agents
- 5.4 Cardiovascular Effects
- 5.5 Do Not Exceed Recommended Dose
- 5.6 Immediate Hypersensitivity Reactions
- 5.7 Coexisting Conditions
- 5.8 Hypokalemia

**6 ADVERSE REACTIONS**

- 6.1 Clinical Trials Experience
- 6.2 Postmarketing Experience

**7 DRUG INTERACTIONS**

- 7.1 Beta-Blockers
- 7.2 Diuretics
- 7.3 Digoxin
- 7.4 Monoamine Oxidase Inhibitors or Tricyclic Antidepressants

**8 USE IN SPECIFIC POPULATIONS**

- 8.1 Pregnancy
- 8.2 Labor and Delivery
- 8.3 Nursing Mothers
- 8.4 Pediatric Use
- 8.5 Geriatric Use

**10 OVERDOSAGE**

**11 DESCRIPTION**

**12 CLINICAL PHARMACOLOGY**

- 12.1 Mechanism of Action
- 12.2 Pharmacokinetics

**13 NONCLINICAL TOXICOLOGY**

- 13.1 Carcinogenesis, Mutagenesis, Impairment of Fertility
- 13.2 Animal Toxicology and/or Pharmacology

**14 CLINICAL STUDIES**

- 14.1 Bronchospasm Associated With Asthma
- 14.2 Exercise-Induced Bronchospasm

**16 HOW SUPPLIED/STORAGE AND HANDLING**

**17 PATIENT COUNSELING INFORMATION**

- 17.1 Frequency of Use
- 17.2 Priming and Cleaning
- 17.3 Dose Counter
- 17.4 Paradoxical Bronchospasm
- 17.5 Concomitant Drug Use
- 17.6 Common Adverse Effects
- 17.7 Pregnancy
- 17.8 FDA-Approved Patient Labeling

\*Sections or subsections omitted from the full prescribing information are not listed.

1

---

2 **FULL PRESCRIBING INFORMATION**

3 **1 INDICATIONS AND USAGE**

4 **1.1 Bronchospasm**

5 VENTOLIN HFA is indicated for the treatment or prevention of bronchospasm in  
6 patients 4 years of age and older with reversible obstructive airway disease.

7 **1.2 Exercise-Induced Bronchospasm**

8 VENTOLIN HFA is indicated for the prevention of exercise-induced bronchospasm in  
9 patients 4 years of age and older.

10 **2 DOSAGE AND ADMINISTRATION**

11 Administer VENTOLIN HFA by oral inhalation only. Shake VENTOLIN HFA well  
12 before each spray.

13 **2.1 Bronchospasm**

14 For treatment of acute episodes of bronchospasm or prevention of symptoms associated  
15 with bronchospasm, the usual dosage for adults and children is 2 inhalations repeated every 4 to  
16 6 hours; in some patients, 1 inhalation every 4 hours may be sufficient. More frequent  
17 administration or a larger number of inhalations is not recommended.

18 **2.2 Exercise-Induced Bronchospasm**

19 The usual dosage for adults and children 4 years of age and older is 2 inhalations 15 to  
20 30 minutes before exercise.

21 **2.3 Administration Information**

22 Priming: Priming VENTOLIN HFA is essential to ensure appropriate albuterol content  
23 in each actuation. Prime VENTOLIN HFA before using for the first time, when the inhaler has  
24 not been used for more than 2 weeks, or when the inhaler has been dropped. To prime  
25 VENTOLIN HFA, release 4 sprays into the air away from the face, shaking well before each  
26 spray.

27 Cleaning: To ensure proper dosing and to prevent actuator orifice blockage, wash the  
28 actuator with warm water and let it air-dry completely at least once a week.

29 Dose Counter: VENTOLIN HFA has a dose counter attached to the canister that starts  
30 at 204 and counts down each time a spray is released. When the counter reads 020, the patient  
31 should contact the pharmacist for a refill of medication or consult the physician to determine  
32 whether a prescription refill is needed.

33 VENTOLIN HFA comes in a moisture-protective foil pouch, which should be removed  
34 prior to use. Discard VENTOLIN HFA when the counter reads 000 (after 200 sprays have been  
35 used) or 6 months after removal from the moisture-protective foil pouch, whichever comes first.

36 See 17.8 FDA-Approved Patient Labeling for instructions on how to prime and clean the  
37 inhaler to ensure proper dosing and to prevent actuator orifice blockage.

38 **3 DOSAGE FORMS AND STRENGTHS**

39 VENTOLIN HFA is an inhalation aerosol. Each actuation contains 108 mcg albuterol  
40 sulfate (90 mcg albuterol base) from the mouthpiece. VENTOLIN HFA is supplied as an 18-g  
41 pressurized aluminum canister with dose counter fitted with a blue plastic actuator and a blue  
42 strapcap. Each canister contains 200 actuations.

43 **4 CONTRAINDICATIONS**

44 VENTOLIN HFA is contraindicated in patients with a history of hypersensitivity to  
45 albuterol or any other components of VENTOLIN HFA. Rare cases of hypersensitivity reactions,  
46 including urticaria, angioedema, and rash have been reported after the use of albuterol sulfate.

47 **5 WARNINGS AND PRECAUTIONS**

48 **5.1 Paradoxical Bronchospasm**

49 Inhaled albuterol sulfate can produce paradoxical bronchospasm, which may be life  
50 threatening. If paradoxical bronchospasm occurs, VENTOLIN HFA should be discontinued  
51 immediately and alternative therapy instituted. It should be recognized that paradoxical  
52 bronchospasm, when associated with inhaled formulations, frequently occurs with the first use of  
53 a new canister.

54 **5.2 Deterioration of Asthma**

55 Asthma may deteriorate acutely over a period of hours or chronically over several days or  
56 longer. If the patient needs more doses of VENTOLIN HFA than usual, this may be a marker of  
57 destabilization of asthma and requires reevaluation of the patient and treatment regimen, giving  
58 special consideration to the possible need for anti-inflammatory treatment, e.g., corticosteroids.

59 **5.3 Use of Anti-Inflammatory Agents**

60 The use of beta-adrenergic agonist bronchodilators alone may not be adequate to control  
61 asthma in many patients. Early consideration should be given to adding anti-inflammatory  
62 agents, e.g., corticosteroids, to the therapeutic regimen.

63 **5.4 Cardiovascular Effects**

64 VENTOLIN HFA, like all other beta<sub>2</sub>-adrenergic agonists, can produce clinically  
65 significant cardiovascular effects in some patients such as changes in pulse rate or blood  
66 pressure. If such effects occur, VENTOLIN HFA may need to be discontinued. In addition, beta-  
67 agonists have been reported to produce electrocardiogram (ECG) changes, such as flattening of  
68 the T wave, prolongation of the QTc interval, and ST segment depression. The clinical relevance  
69 of these findings is unknown. Therefore, VENTOLIN HFA, like all other sympathomimetic  
70 amines, should be used with caution in patients with underlying cardiovascular disorders,  
71 especially coronary insufficiency, cardiac arrhythmias, and hypertension.

72 **5.5 Do Not Exceed Recommended Dose**

73 Fatalities have been reported in association with excessive use of inhaled  
74 sympathomimetic drugs in patients with asthma. The exact cause of death is unknown, but  
75 cardiac arrest following an unexpected development of a severe acute asthmatic crisis and  
76 subsequent hypoxia is suspected.

77 **5.6 Immediate Hypersensitivity Reactions**

78 Immediate hypersensitivity reactions may occur after administration of albuterol sulfate  
79 inhalation aerosol, as demonstrated by cases of urticaria, angioedema, rash, bronchospasm,  
80 anaphylaxis, and oropharyngeal edema. Discontinue VENTOLIN HFA if immediate  
81 hypersensitivity reactions occur.

82 **5.7 Coexisting Conditions**

83 VENTOLIN HFA, like other sympathomimetic amines, should be used with caution in  
84 patients with convulsive disorders, hyperthyroidism, or diabetes mellitus and in patients who are  
85 unusually responsive to sympathomimetic amines. Large doses of intravenous albuterol have  
86 been reported to aggravate preexisting diabetes mellitus and ketoacidosis.

87 **5.8 Hypokalemia**

88 As with other beta-agonists, albuterol may produce significant hypokalemia in some  
89 patients, possibly through intracellular shunting, which has the potential to produce adverse  
90 cardiovascular effects. The decrease is usually transient, not requiring supplementation.

91 **6 ADVERSE REACTIONS**

92 Use of VENTOLIN HFA may be associated with the following:

- 93 • Paradoxical bronchospasm [*see Warnings and Precautions (5.1)*]
- 94 • Cardiovascular effects [*see Warnings and Precautions (5.4)*]
- 95 • Immediate hypersensitivity reactions [*see Warnings and Precautions (5.6)*]
- 96 • Hypokalemia [*see Warnings and Precautions (5.8)*]

97 **6.1 Clinical Trials Experience**

98 The safety data described below reflects exposure to VENTOLIN HFA in 248 patients  
99 treated with VENTOLIN HFA in 3 placebo-controlled clinical trials of 2 to 12 weeks' duration.  
100 The data from adults and adolescents is based upon 2 clinical trials in which 202 patients with  
101 asthma 12 years of age and older were treated with VENTOLIN HFA 2 inhalations 4 times daily  
102 for 12 weeks' duration. The adult/adolescent population was 92 female, 110 male and 163 white,  
103 19 black, 18 Hispanic, 2 other. The data from pediatric patients are based upon 1 clinical trial in  
104 which 46 patients with asthma 4 to 11 years of age were treated with VENTOLIN HFA 2  
105 inhalations 4 times daily for 2 weeks' duration. The population was 21 female, 25 male and 25  
106 white, 17 black, 3 Hispanic, 1 other.

107 Because clinical trials are conducted under widely varying conditions, adverse reaction  
108 rates observed in the clinical trials of a drug cannot be directly compared to rates in the clinical  
109 trials of another drug and may not reflect the rates observed in practice.

110 Adults and Adolescents 12 Years of Age and Older: The two 12-week, randomized,  
111 double-blind studies in 610 adolescent and adult patients with asthma that compared VENTOLIN  
112 HFA, a CFC 11/12-propelled albuterol inhaler, and an HFA-134a placebo inhaler. Overall, the  
113 incidence and nature of the adverse reactions reported for VENTOLIN HFA and a CFC 11/12-  
114 propelled albuterol inhaler were comparable. Table 1 lists the incidence of all adverse reactions  
115 (whether considered by the investigator to be related or unrelated to drug) from these studies that

116 occurred at a rate of 3% or greater in the group treated with VENTOLIN HFA and more  
 117 frequently in the group treated with VENTOLIN HFA than in the HFA-134a placebo inhaler  
 118 group.  
 119

120 **Table 1. Overall Adverse Reactions With  $\geq 3\%$  Incidence in 2 Large 12-Week Clinical**  
 121 **Trials in Adolescents and Adults\***

Adverse Reaction	Percent of Patients		
	VENTOLIN HFA (n = 202) %	CFC 11/12-Propelled Albuterol Inhaler (n = 207) %	Placebo HF-134a (n = 201) %
Ear, nose, and throat			
Throat irritation	10	6	7
Upper respiratory inflammation	5	5	2
Lower respiratory			
Viral respiratory infections	7	4	4
Cough	5	2	2
Musculoskeletal			
Musculoskeletal pain	5	5	4

122 \* This table includes all adverse reactions (whether considered by the investigator to be drug-  
 123 related or unrelated to drug) that occurred at an incidence rate of at least 3.0% in the group  
 124 treated with VENTOLIN HFA and more frequently in the group treated with VENTOLIN  
 125 HFA than in the HFA-134a placebo inhaler group.  
 126

127 Adverse reactions reported by less than 3% of the adolescent and adult patients receiving  
 128 VENTOLIN HFA and by a greater proportion of patients receiving VENTOLIN HFA than  
 129 receiving HFA-134a placebo inhaler and that have the potential to be related to  
 130 VENTOLIN HFA include diarrhea, laryngitis, oropharyngeal edema, cough, lung disorders,  
 131 tachycardia, and extrasystoles. Palpitation and dizziness have also been observed with  
 132 VENTOLIN HFA.

133 **Pediatric Patients:** Results from the 2-week pediatric clinical study in patients with  
 134 asthma 4 to 11 years of age showed that this pediatric population had an adverse reaction profile  
 135 similar to that of the adolescent and adult populations.

136 Three studies have been conducted to evaluate the safety and efficacy of VENTOLIN  
 137 HFA in patients between birth and 4 years of age. The results of these studies did not establish  
 138 the efficacy of VENTOLIN HFA in this age-group [see *Pediatric Use (8.4)*]. Since the efficacy  
 139 of VENTOLIN HFA has not been demonstrated in children between birth and 48 months of age,  
 140 the safety of VENTOLIN HFA in this age-group cannot be established. However, the safety  
 141 profile observed in the pediatric population under 4 years of age was comparable to that  
 142 observed in the older pediatric patients and in adolescents and adults. Where adverse reaction

143 incidence rates were greater in patients under 4 years of age compared with older patients, the  
144 higher incidence rates were noted in all treatment arms, including placebo. These adverse  
145 reactions included upper respiratory tract infection, nasopharyngitis, pyrexia, and tachycardia.

## 146 **6.2 Postmarketing Experience**

147 In addition to the adverse reactions listed in section 6.1, the following adverse reactions  
148 have been identified during postapproval use of VENTOLIN HFA. Because these reactions are  
149 reported voluntarily from a population of uncertain size, it is not always possible to reliably  
150 estimate their frequency or establish a causal relationship to drug exposure.

151 Cases of paradoxical bronchospasm, hoarseness, arrhythmias (including atrial fibrillation,  
152 supraventricular tachycardia), and hypersensitivity reactions (including urticaria, angioedema,  
153 rash) have been reported after the use of VENTOLIN HFA.

154 In addition, albuterol, like other sympathomimetic agents, can cause adverse reactions  
155 such as hypokalemia, hypertension, peripheral vasodilatation, angina, tremor, central nervous  
156 system stimulation, hyperactivity, sleeplessness, headache, muscle cramps, and drying or  
157 irritation of the oropharynx.

## 158 **7 DRUG INTERACTIONS**

159 Other short-acting sympathomimetic aerosol bronchodilators should not be used  
160 concomitantly with albuterol. If additional adrenergic drugs are to be administered by any route,  
161 they should be used with caution to avoid deleterious cardiovascular effects.

### 162 **7.1 Beta-Blockers**

163 Beta-adrenergic receptor blocking agents not only block the pulmonary effect of beta-  
164 agonists, such as VENTOLIN HFA, but may produce severe bronchospasm in patients with  
165 asthma. Therefore, patients with asthma should not normally be treated with beta-blockers.  
166 However, under certain circumstances, e.g., as prophylaxis after myocardial infarction, there may  
167 be no acceptable alternatives to the use of beta-adrenergic blocking agents in patients with  
168 asthma. In this setting, cardioselective beta-blockers should be considered, although they should  
169 be administered with caution.

### 170 **7.2 Diuretics**

171 The ECG changes and/or hypokalemia that may result from the administration of  
172 nonpotassium-sparing diuretics (such as loop or thiazide diuretics) can be acutely worsened by  
173 beta-agonists, especially when the recommended dose of the beta-agonist is exceeded. Although  
174 the clinical relevance of these effects is not known, caution is advised in the coadministration of  
175 beta-agonists with nonpotassium-sparing diuretics. Consider monitoring potassium levels.

### 176 **7.3 Digoxin**

177 Mean decreases of 16% to 22% in serum digoxin levels were demonstrated after single-  
178 dose intravenous and oral administration of albuterol, respectively, to normal volunteers who had  
179 received digoxin for 10 days. The clinical relevance of these findings for patients with  
180 obstructive airway disease who are receiving inhaled albuterol and digoxin on a chronic basis is

181 unclear. Nevertheless, it would be prudent to carefully evaluate the serum digoxin levels in  
182 patients who are currently receiving digoxin and albuterol.

#### 183 **7.4 Monoamine Oxidase Inhibitors or Tricyclic Antidepressants**

184 VENTOLIN HFA should be administered with extreme caution to patients being treated  
185 with monoamine oxidase inhibitors or tricyclic antidepressants, or within 2 weeks of  
186 discontinuation of such agents, because the action of albuterol on the vascular system may be  
187 potentiated. Consider alternative therapy in patients taking MAOs or tricyclic antidepressants.

### 188 **8 USE IN SPECIFIC POPULATIONS**

#### 189 **8.1 Pregnancy**

190 Teratogenic Effects: Pregnancy Category C.

191 There are no adequate and well-controlled studies of VENTOLIN HFA or albuterol  
192 sulfate in pregnant women. During worldwide marketing experience, various congenital  
193 anomalies, including cleft palate and limb defects, have been reported in the offspring of patients  
194 being treated with albuterol. Some of the mothers were taking multiple medications during their  
195 pregnancies. No consistent pattern of defects can be discerned, and a relationship between  
196 albuterol use and congenital anomalies has not been established. Animal reproduction studies in  
197 mice and rabbits revealed evidence of teratogenicity. VENTOLIN HFA should be used during  
198 pregnancy only if the potential benefit justifies the potential risk to the fetus.

199 In a mouse reproduction study, subcutaneously administered albuterol sulfate produced  
200 cleft palate formation in 5 of 111 (4.5%) fetuses at exposures approximately equal to the  
201 maximum recommended human dose (MRHD) for adults on a mg/m<sup>2</sup> basis and in 10 of 108  
202 (9.3%) fetuses at approximately 8 times the MRHD. Similar effects were not observed at  
203 approximately one eleventh of the MRHD. Cleft palate also occurred in 22 of 72 (30.5%) fetuses  
204 from females treated subcutaneously with isoproterenol (positive control).

205 In a rabbit reproduction study, orally administered albuterol sulfate produced  
206 cranioschisis in 7 of 19 fetuses (37%) at approximately 680 times the MRHD.

207 In another rabbit study, an albuterol sulfate/HFA-134a formulation administered by  
208 inhalation produced enlargement of the frontal portion of the fetal fontanelles at approximately  
209 one third of the MRHD [*see Animal Toxicology and/or Pharmacology (13.2)*].

#### 210 **8.2 Labor and Delivery**

211 Because of the potential for beta-agonist interference with uterine contractility, use of  
212 VENTOLIN HFA for relief of bronchospasm during labor should be restricted to those patients  
213 in whom the benefits clearly outweigh the risk.

#### 214 **8.3 Nursing Mothers**

215 Plasma levels of albuterol sulfate and HFA-134a after inhaled therapeutic doses are very  
216 low in humans, but it is not known whether the components of VENTOLIN HFA are excreted in  
217 human milk. Because of the potential for tumorigenicity shown for albuterol in animal studies  
218 and lack of experience with the use of VENTOLIN HFA by nursing mothers, a decision should  
219 be made whether to discontinue nursing or to discontinue the drug, taking into account the



220 importance of the drug to the mother. Caution should be exercised when VENTOLIN HFA is  
221 administered to a nursing woman.

#### 222 **8.4 Pediatric Use**

223 The safety and effectiveness of VENTOLIN HFA in children 4 years of age and older has  
224 been established based upon two 12-week clinical trials in patients 12 years of age and older with  
225 asthma and one 2-week clinical trial in patients 4 to 11 years of age with asthma [*see Clinical*  
226 *Studies (14.1), Adverse Reactions (6.1)*]. The safety and effectiveness of VENTOLIN HFA in  
227 children under 4 years of age has not been established. Three studies have been conducted to  
228 evaluate the safety and efficacy of VENTOLIN HFA in patients under 4 years of age and the  
229 findings are described below.

230 Two 4-week randomized, double-blind, placebo-controlled studies were conducted in 163  
231 pediatric patients from birth to 48 months of age with symptoms of bronchospasm associated  
232 with obstructive airway disease (presenting symptoms included: wheeze, cough, dyspnea, or  
233 chest tightness). VENTOLIN HFA or placebo HFA was delivered with either an AeroChamber  
234 Plus<sup>®</sup> Valved Holding Chamber or an Optichamber<sup>®</sup> Valved Holding Chamber with mask 3  
235 times daily. In one study, VENTOLIN HFA 90 mcg (N = 26), VENTOLIN HFA 180 mcg (N =  
236 25), and placebo HFA (N = 26) were administered to children between 24 and 48 months of age.  
237 In the second study, VENTOLIN HFA 90 mcg (N = 29), VENTOLIN HFA 180 mcg (N = 29),  
238 and placebo HFA (N = 28) were administered to children between birth and 24 months of age.  
239 Over the 4-week treatment period, there were no treatment differences in asthma symptom scores  
240 between the groups receiving VENTOLIN HFA 90 mcg, VENTOLIN HFA 180 mcg, and  
241 placebo in either study.

242 In a third study, VENTOLIN HFA was evaluated in 87 pediatric patients younger than  
243 24 months of age for the treatment of acute wheezing. VENTOLIN HFA was delivered with an  
244 AeroChamber Plus Valved Holding Chamber in this study. There were no significant differences  
245 in asthma symptom scores and mean change from baseline in an asthma symptom score between  
246 VENTOLIN HFA 180 mcg and VENTOLIN HFA 360 mcg.

247 In vitro dose characterization studies were performed to evaluate the delivery of  
248 VENTOLIN HFA via holding chambers with facemasks. The studies were conducted with 2  
249 different holding chambers with facemasks (small and medium size). The in vitro study data  
250 when simulated to patients suggest that the dose of VENTOLIN HFA presented for inhalation  
251 via a valved holding chamber with facemask will be comparable to the dose delivered in adults  
252 without a spacer and facemask per kilogram of body weight (Table 2). However, clinical studies  
253 in children under 4 years of age described above suggest that either the optimal dose of  
254 VENTOLIN HFA has not been defined in this age-group or VENTOLIN HFA is not effective in  
255 this age-group. The safety and effectiveness of VENTOLIN HFA administered with or without a  
256 spacer device in children under 4 years of age has not been demonstrated.

257

258  
259

**Table 2: In Vitro Medication Delivery Through AeroChamber Plus® Valved Holding Chamber With a Facemask**

Age	Facemask	Flow Rate (L/min)	Holding Time (seconds)	Mean Medication Delivery Through AeroChamber Plus (mcg/actuation)	Body Weight 50 <sup>th</sup> Percentile (kg)*	Medication Delivered per Actuation (mcg/kg) <sup>†</sup>
6 to 12 Months	Small	4.9	0	18.2	7.5-9.9	1.8-2.4
			2	19.8		2.0-2.6
			5	13.8		1.4-1.8
			10	15.4		1.6-2.1
2 to 5 Years	Small	8.0	0	17.8	12.3-18.0	1.0-1.4
			2	16.0		0.9-1.3
			5	16.3		0.9-1.3
			10	18.3		1.0-1.5
2 to 5 Years	Medium	8.0	0	21.1	12.3-18.0	1.2-1.7
			2	15.3		0.8-1.2
			5	18.3		1.0-1.5
			10	18.2		1.0-1.5
>5 Years	Medium	12.0	0	26.8	18.0	1.5
			2	20.9		1.2
			5	19.6		1.1
			10	20.3		1.1

260  
261  
262  
263  
264  
265  
266

\* Centers for Disease Control growth charts, developed by the National Center for Health Statistics in collaboration with the National Center for Chronic Disease Prevention and Health Promotion (2000). Ranges correspond to the average of the 50<sup>th</sup> percentile weight for boys and girls at the ages indicated.

† A single inhalation of VENTOLIN HFA in a 70-kg adult without use of a valved holding chamber and facemask delivers approximately 90 mcg, or 1.3 mcg/kg.

267  
268  
269  
270  
271  
272  
273

**8.5 Geriatric Use**

Clinical studies of VENTOLIN HFA did not include sufficient numbers of subjects aged 65 and over to determine whether they respond differently from younger subjects. Other reported clinical experience has not identified differences in responses between the elderly and younger patients. In general, dose selection for an elderly patient should be cautious, usually starting at the low end of the dosing range, reflecting the greater frequency of decreased hepatic, renal, or cardiac function, and of concomitant disease or other drug therapy.

274 **10 OVERDOSAGE**

275 The expected symptoms with overdosage are those of excessive beta-adrenergic  
276 stimulation and/or occurrence or exaggeration of any of the symptoms listed under ADVERSE  
277 REACTIONS, e.g., seizures, angina, hypertension or hypotension, tachycardia with rates up to  
278 200 beats/min, arrhythmias, nervousness, headache, tremor, dry mouth, palpitation, nausea,  
279 dizziness, fatigue, malaise, sleeplessness. Hypokalemia may also occur.

280 As with all sympathomimetic aerosol medications, cardiac arrest and even death may be  
281 associated with abuse of VENTOLIN HFA. Treatment consists of discontinuation of  
282 VENTOLIN HFA together with appropriate symptomatic therapy. The judicious use of a  
283 cardioselective beta-receptor blocker may be considered, bearing in mind that such medication  
284 can produce bronchospasm. There is insufficient evidence to determine if dialysis is beneficial  
285 for overdosage of VENTOLIN HFA.

286 The oral median lethal dose of albuterol sulfate in mice is greater than 2,000 mg/kg  
287 (approximately 6,800 times the maximum recommended daily inhalation dose for adults on a  
288 mg/m<sup>2</sup> basis and approximately 3,200 times the maximum recommended daily inhalation dose  
289 for children on a mg/m<sup>2</sup> basis). In mature rats, the subcutaneous median lethal dose of albuterol  
290 sulfate is approximately 450 mg/kg (approximately 3,000 times the maximum recommended  
291 daily inhalation dose for adults on a mg/m<sup>2</sup> basis and approximately 1,400 times the maximum  
292 recommended daily inhalation dose for children on a mg/m<sup>2</sup> basis). In young rats, the  
293 subcutaneous median lethal dose is approximately 2,000 mg/kg (approximately 14,000 times the  
294 maximum recommended daily inhalation dose for adults on a mg/m<sup>2</sup> basis and approximately  
295 6,400 times the maximum recommended daily inhalation dose for children on a mg/m<sup>2</sup> basis).  
296 The inhalation median lethal dose has not been determined in animals.

297 **11 DESCRIPTION**

298 The active component of VENTOLIN HFA is albuterol sulfate, USP, the racemic form of  
299 albuterol and a relatively selective beta<sub>2</sub>-adrenergic bronchodilator. Albuterol sulfate has the  
300 chemical name α<sup>1</sup>-[(*tert*-butylamino)methyl]-4-hydroxy-*m*-xylene-α, α'-diol sulfate (2:1)(salt)  
301 and the following chemical structure:

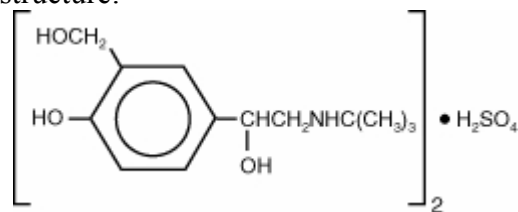

302  
303 Albuterol sulfate is a white crystalline powder with a molecular weight of 576.7, and the  
304 empirical formula is (C<sub>13</sub>H<sub>21</sub>NO<sub>3</sub>)<sub>2</sub>•H<sub>2</sub>SO<sub>4</sub>. It is soluble in water and slightly soluble in ethanol.

305 The World Health Organization recommended name for albuterol base is salbutamol.

306 VENTOLIN HFA is a pressurized metered-dose aerosol unit fitted with a counter.

307 VENTOLIN HFA is intended for oral inhalation only. Each unit contains a microcrystalline

308 suspension of albuterol sulfate in propellant HFA-134a (1,1,1,2-tetrafluoroethane). It contains no  
309 other excipients.

310 Priming VENTOLIN HFA is essential to ensure appropriate albuterol content in each  
311 actuation. To prime the inhaler, release 4 sprays into the air away from the face, shaking well  
312 before each spray. The inhaler should be primed before using it for the first time, when it has not  
313 been used for more than 2 weeks, or when it has been dropped.

314 After priming, each actuation of the inhaler delivers 120 mcg of albuterol sulfate, USP in  
315 75 mg of suspension from the valve and 108 mcg of albuterol sulfate, USP from the mouthpiece  
316 (equivalent to 90 mcg of albuterol base from the mouthpiece).

317 Each 18-g canister provides 200 inhalations.

318 This product does not contain chlorofluorocarbons (CFCs) as the propellant.

## 319 **12 CLINICAL PHARMACOLOGY**

### 320 **12.1 Mechanism of Action**

321 In vitro studies and in vivo pharmacologic studies have demonstrated that albuterol has a  
322 preferential effect on beta<sub>2</sub>-adrenergic receptors compared with isoproterenol. While it is  
323 recognized that beta<sub>2</sub>-adrenergic receptors are the predominant receptors in bronchial smooth  
324 muscle, data indicate that there is a population of beta<sub>2</sub>-receptors in the human heart existing in a  
325 concentration between 10% and 50% of cardiac beta-adrenergic receptors. The precise function  
326 of these receptors has not been established [*see Warnings and Precautions (5.4)*].

327 Activation of beta<sub>2</sub>-adrenergic receptors on airway smooth muscle leads to the activation  
328 of adenylylase and to an increase in the intracellular concentration of cyclic-3',5'-adenosine  
329 monophosphate (cyclic AMP). This increase of cyclic AMP leads to the activation of protein  
330 kinase A, which inhibits the phosphorylation of myosin and lowers intracellular ionic calcium  
331 concentrations, resulting in relaxation. Albuterol relaxes the smooth muscles of all airways, from  
332 the trachea to the terminal bronchioles. Albuterol acts as a functional antagonist to relax the  
333 airway irrespective of the spasmogen involved, thus protecting against all bronchoconstrictor  
334 challenges. Increased cyclic AMP concentrations are also associated with the inhibition of release  
335 of mediators from mast cells in the airway.

336 Albuterol has been shown in most controlled clinical trials to have more effect on the  
337 respiratory tract, in the form of bronchial smooth muscle relaxation, than isoproterenol at  
338 comparable doses while producing fewer cardiovascular effects. Controlled clinical studies and  
339 other clinical experience have shown that inhaled albuterol, like other beta-adrenergic agonist  
340 drugs, can produce a significant cardiovascular effect in some patients, as measured by pulse rate,  
341 blood pressure, symptoms, and/or electrocardiographic changes [*see Warnings and Precautions*  
342 *(5.4)*].

### 343 **12.2 Pharmacokinetics**

344 The systemic levels of albuterol are low after inhalation of recommended doses. A study  
345 conducted in 12 healthy male and female subjects using a higher dose (1,080 mcg of albuterol  
346 base) showed that mean peak plasma concentrations of approximately 3 ng/mL occurred after

347 dosing when albuterol was delivered using propellant HFA-134a. The mean time to peak  
348 concentrations ( $T_{max}$ ) was delayed after administration of VENTOLIN HFA ( $T_{max} = 0.42$  hours)  
349 as compared to CFC-propelled albuterol inhaler ( $T_{max} = 0.17$  hours). Apparent terminal plasma  
350 half-life of albuterol is approximately 4.6 hours. No further pharmacokinetic studies for  
351 VENTOLIN HFA were conducted in neonates, children, or elderly subjects.

## 352 **13 NONCLINICAL TOXICOLOGY**

### 353 **13.1 Carcinogenesis, Mutagenesis, Impairment of Fertility**

354 In a 2-year study in Sprague-Dawley rats, albuterol sulfate caused a dose-related  
355 increase in the incidence of benign leiomyomas of the mesovarium at and above dietary doses  
356 of 2.0 mg/kg (approximately 14 times the maximum recommended daily inhalation dose for  
357 adults on a  $mg/m^2$  basis and approximately 6 times the maximum recommended daily  
358 inhalation dose for children on a  $mg/m^2$  basis). In another study this effect was blocked by the  
359 coadministration of propranolol, a non-selective beta-adrenergic antagonist. In an 18-month  
360 study in CD-1 mice, albuterol sulfate showed no evidence of tumorigenicity at dietary doses of  
361 up to 500 mg/kg (approximately 1,700 times the maximum recommended daily inhalation dose  
362 for adults on a  $mg/m^2$  basis and approximately 800 times the maximum recommended daily  
363 inhalation dose for children on a  $mg/m^2$  basis). In a 22-month study in Golden hamsters,  
364 albuterol sulfate showed no evidence of tumorigenicity at dietary doses of up to 50 mg/kg  
365 (approximately 225 times the maximum recommended daily inhalation dose for adults on a  
366  $mg/m^2$  basis and approximately 110 times the maximum recommended daily inhalation dose for  
367 children on a  $mg/m^2$  basis).

368 Albuterol sulfate was not mutagenic in the Ames test or a mutation test in yeast. Albuterol  
369 sulfate was not clastogenic in a human peripheral lymphocyte assay or in an AH1 strain mouse  
370 micronucleus assay.

371 Reproduction studies in rats demonstrated no evidence of impaired fertility at oral doses  
372 of albuterol sulfate up to 50 mg/kg (approximately 340 times the maximum recommended daily  
373 inhalation dose for adults on a  $mg/m^2$  basis).

### 374 **13.2 Animal Toxicology and/or Pharmacology**

375 Preclinical: Intravenous studies in rats with albuterol sulfate have demonstrated that  
376 albuterol crosses the blood-brain barrier and reaches brain concentrations amounting to  
377 approximately 5.0% of the plasma concentrations. In structures outside the blood-brain barrier  
378 (pineal and pituitary glands), albuterol concentrations were found to be 100 times those in the  
379 whole brain.

380 Studies in laboratory animals (minipigs, rodents, and dogs) have demonstrated the  
381 occurrence of cardiac arrhythmias and sudden death (with histologic evidence of myocardial  
382 necrosis) when beta-agonists and methylxanthines are administered concurrently. The clinical  
383 relevance of these findings is unknown.

384 Propellant HFA-134a is devoid of pharmacological activity except at very high doses in  
385 animals (380 to 1,300 times the maximum human exposure based on comparisons of AUC

386 values), primarily producing ataxia, tremors, dyspnea, or salivation. These are similar to effects  
387 produced by the structurally related CFCs, which have been used extensively in metered-dose  
388 inhalers.

389 In animals and humans, propellant HFA-134a was found to be rapidly absorbed and  
390 rapidly eliminated, with an elimination half-life of 3 to 27 minutes in animals and 5 to 7 minutes  
391 in humans. Time to maximum plasma concentration ( $T_{max}$ ) and mean residence time are both  
392 extremely short, leading to a transient appearance of HFA-134a in the blood with no evidence of  
393 accumulation.

394 Reproductive Toxicology Studies: A study in CD-1 mice given albuterol sulfate  
395 subcutaneously showed cleft palate formation in 5 of 111 (4.5%) fetuses at 0.25 mg/kg (less than  
396 the maximum recommended daily inhalation dose for adults on a  $mg/m^2$  basis) and in 10 of 108  
397 (9.3%) fetuses at 2.5 mg/kg (approximately 8 times the maximum recommended daily inhalation  
398 dose for adults on a  $mg/m^2$  basis). The drug did not induce cleft palate formation at a dose of  
399 0.025 mg/kg (less than the maximum recommended daily inhalation dose for adults on a  $mg/m^2$   
400 basis). Cleft palate also occurred in 22 of 72 (30.5%) fetuses from females treated  
401 subcutaneously with 2.5 mg/kg of isoproterenol (positive control).

402 A reproduction study in Stride Dutch rabbits revealed cranioschisis in 7 of 19 fetuses  
403 (37%) when albuterol sulfate was administered orally at a 50 mg/kg dose (approximately 680  
404 times the maximum recommended daily inhalation dose for adults on a  $mg/m^2$  basis).

405 In an inhalation reproduction study in New Zealand white rabbits, albuterol sulfate/HFA-  
406 134a formulation exhibited enlargement of the frontal portion of the fetal fontanelles at and  
407 above inhalation doses of 0.0193 mg/kg (less than the maximum recommended daily inhalation  
408 dose for adults on a  $mg/m^2$  basis).

409 A study in which pregnant rats were dosed with radiolabeled albuterol sulfate  
410 demonstrated that drug-related material is transferred from the maternal circulation to the fetus.

## 411 **14 CLINICAL STUDIES**

### 412 **14.1 Bronchospasm Associated With Asthma**

413 Adult and Adolescent Patients 12 Years of Age and Older: The efficacy of  
414 VENTOLIN HFA was evaluated in two 12-week, randomized, double-blind, placebo controlled  
415 trials in patients 12 years of age and older with mild to moderate asthma. These trials included a  
416 total of 610 patients (323 males, 287 females). In each trial, patients received 2 inhalations of  
417 VENTOLIN HFA, CFC 11/12-propelled albuterol, or HFA-134a placebo 4 times daily for 12  
418 weeks' duration. Patients taking the HFA-134a placebo inhaler also took VENTOLIN HFA for  
419 asthma symptom relief on an as-needed basis. Some patients who participated in these clinical  
420 trials were using concomitant inhaled steroid therapy. Efficacy was assessed by serial forced  
421 expiratory volume in 1 second ( $FEV_1$ ). In each of these trials, 2 inhalations of VENTOLIN HFA  
422 produced significantly greater improvement in  $FEV_1$  over the pretreatment value than placebo.  
423 Results from the 2 clinical trials are described below.

424 In a 12-week, randomized, double-blind study, VENTOLIN HFA (101 patients) was  
425 compared to CFC 11/12-propelled albuterol (99 patients) and an HFA-134a placebo inhaler (97  
426 patients) in adolescent and adult patients 12 to 76 years of age with mild to moderate asthma.  
427 Serial FEV<sub>1</sub> measurements [shown below as percent change from test-day baseline at Day 1  
428 (n = 297) and at Week 12 (n = 249)] demonstrated that 2 inhalations of VENTOLIN HFA  
429 produced significantly greater improvement in FEV<sub>1</sub> over the pretreatment value than placebo.  
430

431 **FEV<sub>1</sub> as Percent Change From Predose in a Large,**  
432 **12-Week Clinical Trial**

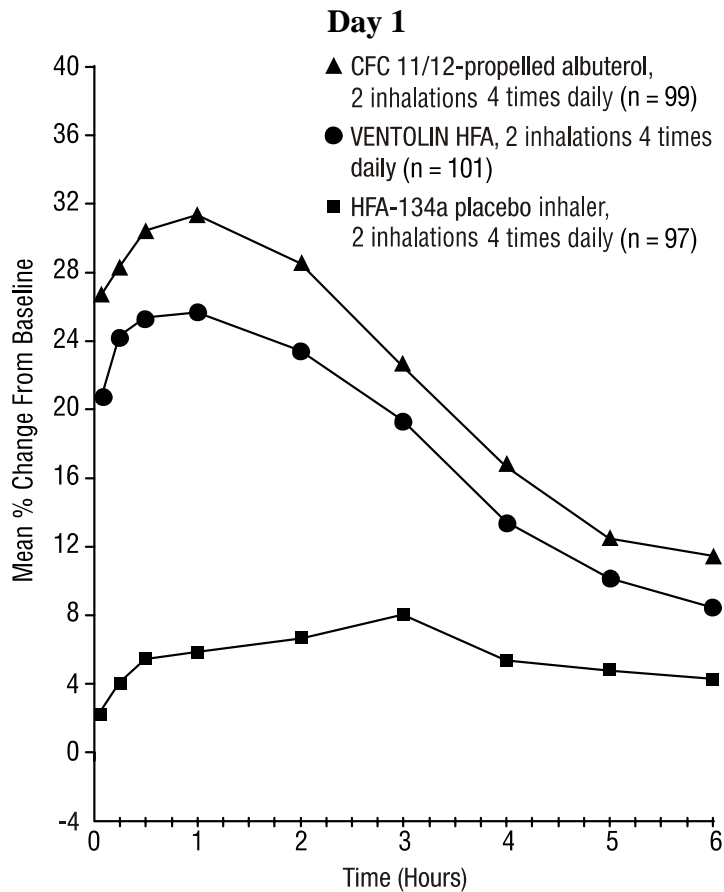

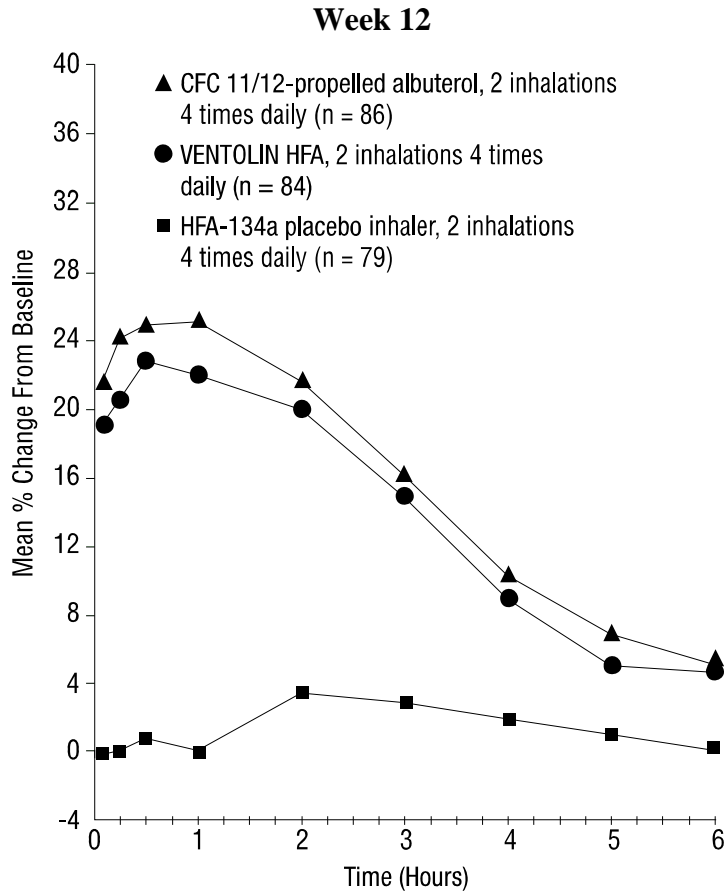

438

439

440 In the responder population ( $\geq 15\%$  increase in  $FEV_1$  within 30 minutes postdose) treated  
 441 with VENTOLIN HFA, the mean time to onset of a 15% increase in  $FEV_1$  over the pretreatment  
 442 value was 5.4 minutes, and the mean time to peak effect was 56 minutes. The mean duration of  
 443 effect as measured by a 15% increase in  $FEV_1$  over the pretreatment value was approximately  
 444 4 hours. In some patients, duration of effect was as long as 6 hours.

445 The second 12-week randomized, double-blind study was conducted to evaluate the  
 446 efficacy and safety of switching patients from CFC 11/12-propelled albuterol to VENTOLIN  
 447 HFA. During the 3-week run-in phase of the study, all patients received CFC 11/12-propelled  
 448 albuterol. During the double-blind treatment phase, VENTOLIN HFA (91 patients) was  
 449 compared to CFC 11/12-propelled albuterol (100 patients) and an HFA-134a placebo inhaler (95  
 450 patients) in adolescent and adult patients with mild to moderate asthma. Serial  $FEV_1$   
 451 measurements demonstrated that 2 inhalations of VENTOLIN HFA produced significantly  
 452 greater improvement in pulmonary function than placebo. The switching from CFC 11/12-  
 453 propelled albuterol inhaler to VENTOLIN HFA did not reveal any clinically significant changes  
 454 in the efficacy profile.

455 In the 2 adult studies, the efficacy results from VENTOLIN HFA were significantly  
 456 greater than placebo and were clinically comparable to those achieved with CFC 11/12-propelled  
 457 albuterol, although small numerical differences in mean  $FEV_1$  response and other measures were



458 observed. Physicians should recognize that individual responses to beta-adrenergic agonists  
459 administered via different propellants may vary and that equivalent responses in individual  
460 patients should not be assumed.

461 Pediatric Patients 4 Years of Age: The efficacy of VENTOLIN HFA was evaluated in  
462 one 2-week, randomized, double-blind, placebo-controlled trial in 135 pediatric patients 4 to 11  
463 years of age with mild to moderate asthma. In this trial, patients received VENTOLIN HFA,  
464 CFC 11/12-propelled albuterol, or HFA-134a placebo. Serial pulmonary function measurements  
465 demonstrated that 2 inhalations of VENTOLIN HFA produced significantly greater improvement  
466 in pulmonary function than placebo and that there were no significant differences between the  
467 groups treated with VENTOLIN HFA and CFC 11/12-propelled albuterol. In the responder  
468 population treated with VENTOLIN HFA, the mean time to onset of a 15% increase in peak  
469 expiratory flow rate (PEFR) over the pretreatment value was 7.8 minutes, and the mean time to  
470 peak effect was approximately 90 minutes. The mean duration of effect as measured by a 15%  
471 increase in PEFR over the pretreatment value was greater than 3 hours. In some patients,  
472 duration of effect was as long as 6 hours.

#### 473 **14.2 Exercise-Induced Bronchospasm**

474 One controlled clinical study in adult patients with asthma (N = 24) demonstrated that  
475 2 inhalations of VENTOLIN HFA taken approximately 30 minutes prior to exercise significantly  
476 prevented exercise-induced bronchospasm (as measured by maximum percentage fall in FEV<sub>1</sub>  
477 following exercise) compared to an HFA-134a placebo inhaler. In addition, VENTOLIN HFA  
478 was shown to be clinically comparable to a CFC 11/12-propelled albuterol inhaler for this  
479 indication.

## 480 **16 HOW SUPPLIED/STORAGE AND HANDLING**

481 VENTOLIN HFA (albuterol sulfate) Inhalation Aerosol is supplied as a pressurized  
482 aluminum canister fitted with a counter with a blue plastic actuator and a blue strapcap packaged  
483 within a moisture-protective foil pouch, each in boxes of 1 (NDC 0173-0682-20). The moisture-  
484 protective foil pouch also contains a desiccant.

485 Before using, VENTOLIN HFA should be removed from the moisture-protective foil  
486 pouch. The pouch and desiccant should be discarded. VENTOLIN HFA should be discarded 6  
487 months after removal from the pouch.

488 Priming VENTOLIN HFA is essential to ensure appropriate albuterol content in each  
489 actuation. To prime the inhaler, release 4 sprays into the air away from the face, shaking well  
490 before each spray. The inhaler should be primed before using it for the first time, when the  
491 inhaler has not been used for more than 2 weeks, or when it has been dropped.

492 After priming, each actuation delivers 120 mcg of albuterol sulfate, USP in 75 mg of  
493 suspension from the valve and 108 mcg of albuterol sulfate, USP from the mouthpiece  
494 (equivalent to 90 mcg of albuterol base from the mouthpiece). The canister is labeled with a net  
495 weight of 18 g and contains 200 metered inhalations.

496 To ensure proper dosing and to prevent actuator orifice blockage, wash the actuator with  
497 warm water and let it air-dry completely at least once a week [*see FDA-Approved Patient*  
498 *Labeling (17.8)*].

499 The blue actuator supplied with VENTOLIN HFA should not be used with any other  
500 product canisters, and actuators from other products should not be used with a VENTOLIN HFA  
501 canister.

502 VENTOLIN HFA has a counter attached to the canister. The counter starts at 204 and  
503 counts down each time a spray is released. The correct amount of medication in each inhalation  
504 cannot be assured after the counter reads 000, even though the canister is not completely empty  
505 and will continue to operate. VENTOLIN HFA should be discarded when the counter reads 000  
506 (after 200 sprays have been used) or 6 months after removal from the moisture-protective foil  
507 pouch, whichever comes first. Never immerse the canister in water to determine the amount of  
508 drug remaining in the canister.

509 Keep out of reach of children. Avoid spraying in eyes.

510 Contents Under Pressure: Do not puncture. Do not use or store near heat or open flame.  
511 Exposure to temperatures above 120°F may cause bursting. Never throw container into fire or  
512 incinerator.

513 Store between 15° and 25°C (59° and 77°F). Store the inhaler with the mouthpiece down.  
514 For best results, the inhaler should be at room temperature before use. SHAKE WELL BEFORE  
515 EACH SPRAY.

516 VENTOLIN HFA does not contain chlorofluorocarbons (CFCs) as the propellant.

## 517 **17 PATIENT COUNSELING INFORMATION**

518 *See FDA-Approved Patient Labeling (17.8)*

### 519 **17.1 Frequency of Use**

520 The action of VENTOLIN HFA should last up to 4 to 6 hours. VENTOLIN HFA should  
521 not be used more frequently than recommended. Do not increase the dose or frequency of doses  
522 of VENTOLIN HFA without consulting the physician. If patients find that treatment with  
523 VENTOLIN HFA becomes less effective for symptomatic relief, symptoms become worse,  
524 and/or they need to use the product more frequently than usual, they should seek medical  
525 attention immediately.

### 526 **17.2 Priming and Cleaning**

527 Priming: Patients should be instructed that priming VENTOLIN HFA is essential to  
528 ensure appropriate albuterol content in each actuation. Patients should prime VENTOLIN HFA  
529 before using for the first time, when the inhaler has not been used for more than 2 weeks, or  
530 when the inhaler has been dropped. To prime VENTOLIN HFA, patients should release 4 sprays  
531 into the air away from the face, shaking well before each spray.

532 Cleaning: To ensure proper dosing and to prevent actuator orifice blockage, patients  
533 should be instructed to wash the actuator and dry thoroughly at least once a week. Patients

534 should be informed that detailed cleaning instructions are included in the Information for the  
535 Patient leaflet.

### 536 **17.3 Dose Counter**

537 Patients should be informed that VENTOLIN HFA has a dose counter that starts at 204  
538 and counts down each time a spray is released. Patients should be informed to discard  
539 VENTOLIN HFA when the counter reads 000 (after 200 sprays have been used) or 6 months  
540 after removal from the moisture-protective foil pouch, whichever comes first. When the counter  
541 reads 020, the patient should contact the pharmacist for a refill of medication or consult the  
542 physician to determine whether a prescription refill is needed. Patients should never try to alter  
543 the numbers or remove the counter from the metal canister. Patients should never immerse the  
544 canister in water to determine the amount of drug remaining in the canister.

### 545 **17.4 Paradoxical Bronchospasm**

546 Patients should be informed that VENTOLIN HFA can produce paradoxical  
547 bronchospasm. If paradoxical bronchospasm occurs, patients should discontinue VENTOLIN  
548 HFA.

### 549 **17.5 Concomitant Drug Use**

550 While patients are using VENTOLIN HFA, other inhaled drugs and asthma medications  
551 should be taken only as directed by the physician.

### 552 **17.6 Common Adverse Effects**

553 Common adverse effects of treatment with inhaled albuterol include palpitations, chest  
554 pain, rapid heart rate, tremor, and nervousness.

### 555 **17.7 Pregnancy**

556 Patients who are pregnant or nursing should contact their physicians about the use of  
557 VENTOLIN HFA.

### 558 **17.8 FDA-Approved Patient Labeling**

559 *See tear-off leaflet below.*

560

561 VENTOLIN is a registered trademark of GlaxoSmithKline.

562 AeroChamber Plus is a registered trademark of Monaghan Medical Inc.

563 OptiChamber is a registered trademark of Respironics Inc.

564

565



GlaxoSmithKline

566

567 GlaxoSmithKline

568 Research Triangle Park, NC 27709

569

570 ©2008, GlaxoSmithKline. All rights reserved.

571

572

573

574

575

**Information for the Patient**

576

**VENTOLIN<sup>®</sup> HFA**

577

**(albuterol sulfate)**

578

**Inhalation Aerosol**

579 Read this leaflet carefully before you start to use VENTOLIN HFA.

580 Keep this leaflet because it has important summary information about VENTOLIN HFA. Your  
581 healthcare provider has more information or advice.

582 Read the new leaflet that comes with each refill of your prescription because there may be new  
583 information.

584

**What is VENTOLIN HFA?**

585 VENTOLIN HFA is a kind of medicine called a fast-acting bronchodilator. Fast-acting  
586 bronchodilators help to quickly open the airways in your lungs so that you can breathe more  
587 easily.

588 Each dose of VENTOLIN HFA should last up to 4 to 6 hours.

589 Take VENTOLIN HFA as directed by your doctor. Do not take extra doses or take more often  
590 without asking your doctor.

591 Get medical help right away if VENTOLIN HFA no longer helps your symptoms. Also get  
592 medical help if your symptoms get worse or if you need to use your inhaler more often.

593 While you are using VENTOLIN HFA, use other inhaled medicines and asthma medicines only  
594 as directed by your doctor. Tell your doctor if you are pregnant or nursing, and ask about the use  
595 of VENTOLIN HFA.

596 Possible side effects of taking VENTOLIN HFA include fast or irregular heartbeat, chest pain,  
597 shakiness, and nervousness. With the first use of a new canister, worsening of wheezing may  
598 occur.

599 **The parts of your VENTOLIN HFA inhaler:**

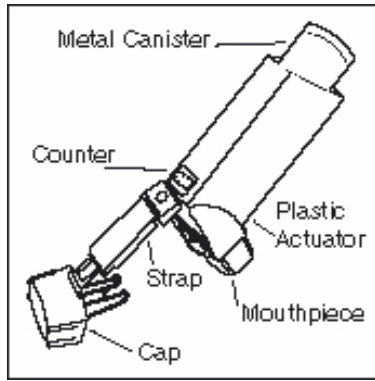

**Figure 1**

602 There are 2 main parts to your VENTOLIN HFA  
 603 inhaler—the metal canister that holds the medicine  
 604 and the blue plastic actuator that sprays the  
 605 medicine from the canister (see Figure 1).

606 The inhaler also has a cap that covers the  
 607 mouthpiece of the actuator. The strap on the cap  
 608 will stay attached to the actuator.

609 **Do not use the actuator with a canister of**  
 610 **medicine from any other inhaler. And do not use**  
 611 **a VENTOLIN HFA canister with an actuator**  
 612 **from any other inhaler.**

600  
 601

613 The canister has a counter to show how many sprays of medicine you have left. The number  
 614 shows through a window in the back of the actuator.

615 The counter starts at 204. The number will count down by 1 each time you spray the inhaler. The  
 616 counter will stop counting at 000.

617 **Never try to change the numbers or take the counter off the metal canister.** The counter  
 618 cannot be reset, and it is permanently attached to the canister.

**How to Use Your VENTOLIN HFA**

619

**Before using your VENTOLIN HFA:**

620

621 Take the inhaler out of the foil pouch. Safely throw away the pouch and the drying packet that  
 622 comes inside the pouch. The counter should read 204.

623 If a child needs help using the inhaler, an adult should help the child use the inhaler with or  
 624 without a holding chamber attached to a facemask. The adult should follow the instructions that  
 625 came with the holding chamber. An adult should watch a child use the inhaler to be sure it is used  
 626 correctly.

627 The inhaler should be at room temperature before you use it.

628 Check each time to make sure the canister fits firmly in the plastic actuator. Also look into the  
 629 mouthpiece to make sure there are no foreign objects there, especially if the strap is no longer  
 630 attached to the actuator or if the cap is not being used to cover the mouthpiece.

**Priming your VENTOLIN HFA:**

631

632 You must prime the inhaler to get the right amount of medicine. Prime the inhaler before you use  
 633 it for the first time, if you have not used it for more than 14 days, or if it has been dropped. To  
 634 prime the inhaler, take the cap off the mouthpiece of the actuator. Then shake the inhaler well,  
 635 and spray it into the air away from your face. Shake and spray the inhaler like this 3 more times  
 636 to finish priming it. The counter should now read 200.

637 **Instructions for taking a dose from your VENTOLIN HFA:**  
638 Read through the 6 steps below before using VENTOLIN HFA. If you have any questions, ask  
639 your doctor or pharmacist.

640 1. Take the cap off the mouthpiece of the actuator. **Shake the inhaler well** before each spray.  
641

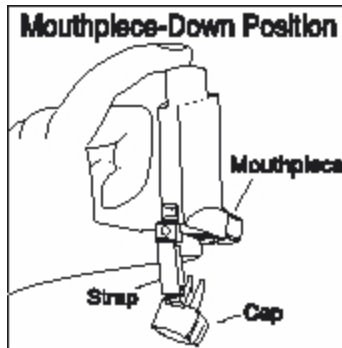

642 **Figure 2**

643 2. Hold the inhaler with the mouthpiece down (see Figure 2). **Breathe out through your**  
644 **mouth** and push as much air from your lungs as you can. Put the mouthpiece in your mouth  
645 and close your lips around it.  
646 3. **Push the top of the canister all the way down while you breathe in deeply and slowly**  
647 **through your mouth** (see Figure 3). Right after the spray comes out, take your finger off the  
648 canister. After you have breathed in all the way, take the inhaler out of your mouth and close  
649 your mouth.  
650  
651  
652

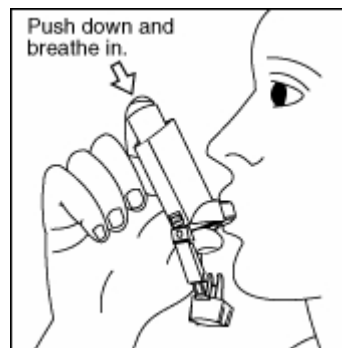

653 **Figure 3**

654 4. **Hold your breath as long as you can**, up to 10 seconds, then breathe normally.  
655 5. If your doctor has prescribed more sprays, wait 1 minute and **shake** the inhaler again. Repeat  
656 steps 2 through 4.  
657 6. Put the cap back on the mouthpiece after every time you use the inhaler, and make sure it  
658 snaps firmly into place.  
659  
660

661

**When to Replace Your VENTOLIN HFA**

662  
663

• **When the counter reads 020**, you should refill your prescription or ask your doctor if you need another prescription for VENTOLIN HFA.

664  
665  
666

• **Throw the inhaler away** when the counter reads 000 or 6 months after you have taken the inhaler out of the foil pouch, whichever happens first. You should not keep using the inhaler when the counter reads 000 because you will not receive the right amount of medicine.

667

• **Do not use the inhaler** after the expiration date, which is on the packaging it comes in.

668

**How to Clean Your VENTOLIN HFA**

669  
670  
671

**It is very important to keep the plastic actuator clean so the medicine will not build-up and block the spray. Do not try to clean the metal canister or let it get wet.** The inhaler may stop spraying if it is not cleaned correctly.

672

Wash the actuator at least once a week.

673

**Cleaning instructions:**

674  
675

1. Take the canister out of the actuator, and take the cap off the mouthpiece. The strap on the cap will stay attached to the actuator.

676  
677

2. Wash the actuator through the top with warm running water for 30 seconds (see Figure 4). Then wash the actuator again through the mouthpiece (see Figure 5).

678

681

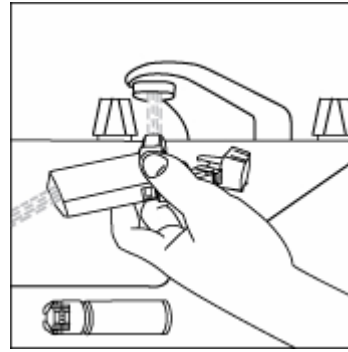
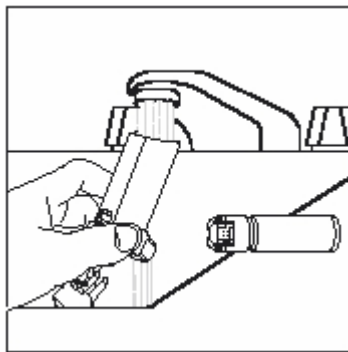

679  
680  
684

**Figure 4**

682  
683

**Figure 5**

685  
686  
687

3. Shake off as much water from the actuator as you can. Look into the mouthpiece to make sure any medicine build-up has been completely washed away. If there is any build-up, repeat step 2.

688  
689

4. Let the actuator air-dry completely, such as overnight (see Figure 6).

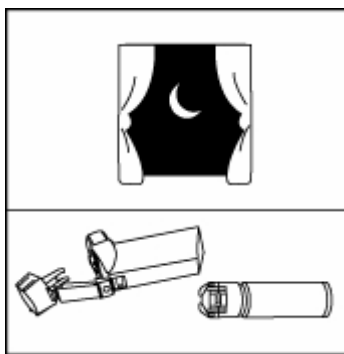

Figure 6

690  
691  
692

693 5. When the actuator is dry, put the canister in the actuator and make sure it fits firmly. Shake  
694 the inhaler well and spray it once into the air away from your face. (The counter will count  
695 down by 1.) Put the cap back on the mouthpiece.

696 **If your actuator becomes blocked:**

697 Blockage from medicine build-up is more likely to happen if you do not let the actuator air-dry  
698 completely. If the actuator gets blocked so that little or no medicine comes out of the mouthpiece  
699 (see Figure 7), wash the actuator as described in cleaning steps 1-5.

700

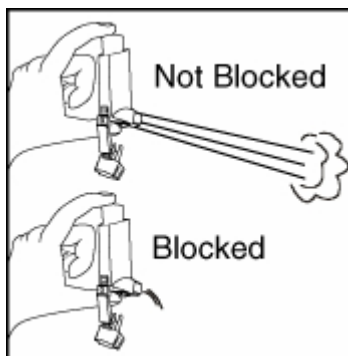

Figure 7

701  
702  
703

704 **If you need to use your inhaler before the actuator is completely dry, shake as much water**  
705 **off the actuator as you can.** Put the canister in the actuator and make sure it fits firmly. Shake  
706 the inhaler well and spray it once into the air away from your face. Then take your dose as  
707 prescribed. Then clean and air-dry it completely.

708

**Storing Your VENTOLIN HFA**

709 **Store at room temperature with the mouthpiece down.** Keep out of reach of children.

710 **Contents Under Pressure:** Do not puncture. Do not use or store near heat or open flame.

711 Exposure to temperatures above 120°F may cause bursting. Never throw into fire or incinerator.

712  
713





GlaxoSmithKline

714

715 GlaxoSmithKline

716 Research Triangle Park, NC 27709

717

718 March 2008

VNT:2PIL