

Protection Against Electric Shock in Laboratory Sea-Water Systems

**by James M. Crossen,
with a contribution by Paul S. Galtsoff**

**Prepared 1966
Issued 2006**

Recent Issues in This Series

- 06-09 **42nd Northeast Regional Stock Assessment Workshop (42nd SAW) Stock Assessment Report**, by the Northeast Fisheries Science Center. May 2006.
- 06-10 **Assessment of the Georges Bank Atlantic Cod Stock for 2005**, by L O'Brien, N Shepherd, and L Col. June 2006.
- 06-11 **Stock Assessment of Georges Bank Haddock, 1931-2004**, by J Brodziak, M Traver, L Col, and S Sutherland. June 2006.
- 06-12 **Report from the Atlantic Surfclam (*Spisula solidissima*) Aging Workshop Northeast Fisheries Science Center, Woods Hole, MA, 7-9 November 2005**, by L Jacobson, S Sutherland, J Burnett, M Davidson, J Harding, J Normant, A Picariello, and E Powell. July 2006.
- 06-13 **Estimates of Cetacean and Seal Bycatch in the 2004 Northeast Sink Gillnet and Mid-Atlantic Coastal Gillnet Fisheries**, by DL Belden, CD Orphanides, MC Rossman, and DL Palka. July 2006.
- 06-14 **43rd SAW Assessment Summary Report**, by the 43rd Northeast Regional Stock Assessment Workshop. July 2006.
- 06-15 **Documentation for the Energy Modeling and Analysis eXercise (EMAX)**, by JS Link, CA Griswold, ET Methratta, and J Gunnard, Editors. August 2006.
- 06-16 **Northeast Fisheries Science Center Publications, Reports, and Abstracts for Calendar Year 2005**, by L Garner and J Gunnard. August 2006
- 06-17 **Stock Assessment of Summer Flounder for 2006**, by M Terceiro. August 2006.
- 06-18 **Environmental Preferences of Herring under Changing Harvest Regimes**, by KD Friedland, JE O'Reilly, JA Hare, GB Wood, WJ Overholtz, and MD Cieri. August 2006.
- 06-19 **Estimated Average Annual Bycatch of Loggerhead Sea Turtles (*Caretta caretta*) in U.S. Mid-Atlantic Bottom Otter Trawl Gear, 1996-2004**, by KT Murray. September 2006.
- 06-20 **Sea Scallop Stock Assessment Update for 2005**, by DR Hart. September 2006.
- 06-21 **A Laboratory Guide to the Identification of Marine Fish Eggs Collected on the Northeast Coast of the United States, 1977-1994**, by PL Berrien and JD Sibunka. September 2006.
- 06-22 **The Analytic Component to the Standardized Bycatch Reporting Methodology Omnibus Amendment: Sampling Design, and Estimation of Precision and Accuracy**, by SE Wigley, PJ Rago, KA Sosebee, and DL Palka. September 2006.
- 06-23 **Tenth Flatfish Biology Conference, November 29-30, 2006, Water's Edge Resort, Westbrook, Connecticut**, by R Mercaldo-Allen (chair), A Calabrese, DJ Danila, MS Dixon, A Jearld, TA Munroe, DJ Pacileo, C Powell, SJ Sutherland, steering committee members. October 2006.
- 06-24 **Analysis of Virginia fisheries effort as a component in the development of a fisheries sampling plan to investigate the causes of sea turtle strandings**, by CM Legault and KD Bisack. October 2006.
- 06-25 **43rd Northeast Regional Stock Assessment Workshop (43rd SAW): 43rd SAW Assessment Report**, by Northeast Fisheries Science Center. November 2006.

Protection Against Electric Shock in Laboratory Sea-Water Systems

**by James M. Crossen,
with a contribution by Paul S. Galtsoff**

**U.S. DEPARTMENT OF COMMERCE
National Oceanic and Atmospheric Administration
National Marine Fisheries Service
Northeast Fisheries Science Center
Woods Hole, Massachusetts**

**Prepared 1966
Issued 2006**

Northeast Fisheries Science Center Reference Documents

This series is a secondary scientific series designed to assure the long-term documentation and to enable the timely transmission of research results by Center and/or non-Center researchers, where such results bear upon the research mission of the Center (see the outside back cover for the mission statement). These documents receive internal scientific review but no technical or copy editing. The National Marine Fisheries Service does not endorse any proprietary material, process, or product mentioned in these documents.

All documents issued in this series since April 2001, and several documents issued prior to that date, have been copublished in both paper and electronic versions. To access the electronic version of a document in this series, go to <http://www.nefsc.noaa.gov/nefsc/publications/series/crdlist.htm>. The electronic version will be available in PDF format to permit printing of a paper copy directly from the Internet. If you do not have Internet access, or if a desired document is one of the pre-April 2001 documents available only in the paper version, you can obtain a paper copy by contacting the senior Center author of the desired document. Refer to the title page of the desired document for the senior Center author's name and mailing address. If there is no Center author, or if there is corporate (*i.e.*, non-individualized) authorship, then contact the Center's Woods Hole Laboratory Library (166 Water St., Woods Hole, MA 02543-1026).

This document's publication history is as follows: manuscript submitted for review July 19, 2006; manuscript accepted through technical review September 22, 2006; manuscript accepted through policy review September 25, 2006; and final copy submitted for publication September 25, 2006. This document may be cited as:

Crossen JM, Galtsoff PS, Gibson JA (ed). 2006. Protection against electric shock in laboratory sea-water systems. US Dep. Commer., *Northeast Fish. Sci. Cent. Ref. Doc.* 06-26; 20 p. Available from: National Marine Fisheries Service, 166 Water Street, Woods Hole, MA 02543-1026.

FOREWORD

In January 2006, Jim Crossen brought this paper into the Editorial Office of the Northeast Fisheries Science Center (NEFSC). Jim indicated that he, as an employee of the Woods Hole Biological Laboratory of the Bureau of Commercial Fisheries (forerunner of the National Marine Fisheries Service), had authored the paper in 1966, but had not placed it in the *Woods Hole Laboratory Reference Document* series at that time. He felt that the information in the paper had some lasting value, and asked that the paper be handled in a manner to assure its retention by the NEFSC. Accordingly, the Editorial Office has issued this paper as an “unpublished paper” which will be included in the listing of 2006 reports prepared by NEFSC authors, and will be available through that listing on the NEFSC’s publications webpage (www.nefsc.noaa.gov/nefsc/publications/lists/lists.htm).

Workplace safety has always been a serious concern of organizations and their members, although one could argue that the subject has been taken more seriously in the 40 years between when this paper was prepared and when it was issued. What is not arguable is that workplace safety has been far more institutionalized in those four decades. Today, there are laws, regulations, agencies, and specialized/dedicated personnel all addressing aspects of workplace safety. Therein lies the importance of, and interest in, this paper: it largely reflects the “pre-institutionalized” approach to workplace safety. Individual initiative, investigation, fabrication, and evaluation were the means by which a potentially serious safety problem at the Woods Hole Laboratory was solved.

Jim Crossen authored all of the paper except for the section on “Fouling Analysis.” Paul Galtsoff, the Director Emeritus of the Woods Hole Laboratory, performed such analysis and wrote the associated section. Unfortunately, Tables 6 and 7 of the paper have been lost through the passage of time.

I have made some changes to the paper, and they need to be listed in order to differentiate between the paper as originally prepared and as issued. I prepared the title page, foreword, table of contents, and figure captions. In the original paper, most of the pages were not numbered; in the new table of contents, the implied page numbers of the various components of the paper are indicated by numbers within squared brackets. In the original paper, there were no figure captions associated with the figure images; I prepared those captions based upon the text descriptions and language. Additionally, at some point subsequent to 1966, someone had reviewed the paper and had scrawled a few comments directly onto the paper in pencil and ink. I removed those comments.

Jon A. Gibson
Biological Sciences Editor
Northeast Fisheries Science Center
April 19, 2006

Table of Contents

Abstract.....	[vii]
[Introduction]	[1]
Electrical Shock Incident	2
Safeguard Methods	3
Electrode Installation	[5]
Electrode Maintenance.....	[6]
Fouling Analysis	[7]
Discussion.....	[9]
Literature Cited	[11]

List of Tables

Table 1. Sea water capacity of Woods Hole system	[12]
Table 2. Body reaction to electric current	[13]
Table 3. Resistance values in ohms	[14]
Table 4. Specific resistance	[15]
Table 5. Galvanic series	[16]
Table 6. [missing]	
Table 7. [missing]	

List of Figures

Figure 1. Diagram of overall salt water system at Woods Hole.....	[17]
Figure 2. Diagram of salt water reservoir tank at Woods Hole.....	[18]
Figure 3. <i>A</i> : Diagram of salt water system for first floor of main lab (ocean side) at Woods Hole; <i>B</i> : Diagram of salt water system for just Room 111 at Woods Hole.....	[19]
Figure 4. Pipe used throughout Woods Hole system, showing functional electrode setup	[20]
Figure 5. <i>Top</i> : Not-yet-machined, 5/8-inch, plastic plug; <i>Middle</i> : Not-yet-assembled, 5/16 x 6-inch, graphite electrode; <i>Bottom</i> : Assembled, platinized, titanium electrode	[21]
Figure 6. Diagram of portable probe	[22]

ABSTRACT

An electrical shock hazard can exist to personnel in modern sea-water systems which use hard rubber and synthetic piping. A method, non-toxic to marine life, is described herein which safeguards personnel against electric shock by the insertion of grounded platinized titanium electrodes in the system.

The Bureau of Commercial Fisheries Biological Laboratory at Woods Hole, Massachusetts, maintains a salt water supply system with a capacity of 76,000 gallons. This system provides a water supply for the main laboratory and for the public aquarium. A breakdown of the total water capacity is given in Table 1. A diagram of the salt water system at Woods Hole is shown in Figure 1.

Sea water supply systems for aquaria which have in the past used metallic piping, not utilize non-corrosive hard rubber and poly-vinyl-chloride (PVC) type plastics. While the latter has eliminated the problems of toxicity to fish inherent in the combination of salt water and metals, it has presented a potential shock hazard to personnel.

Modern sea water systems such as that at Woods Hole which supply experimental aquaria are carefully designed to avoid the use of metals. Most metals exposed to salt water corrode to some degree due to galvanic action resulting in the liberation of ions which are toxic to some marine organisms.

Chemically inert materials such as hard rubber, polyurethane, poly-vinyl-chloride, epoxy base sealers, vulcanite, ebonite, wood covered with black asphaltum are non-conductors of electricity.

The Woods Hole system utilizes "Uscolite," a synthetic rubber material (styrene acrylonitriles – butadiene copolymer) for the piping. The iron reservoir tank is coated with "Gunite,"

and insulating cement. Under certain conditions, that is, when water is not being pumped into the reservoir tank (see Figure 2) and is not being returned to the harbor through drains, a floating system exists without an electrical ground return.

Electrical Shock Incident

The following is an account of an electrical shock problem which took place in the main laboratory of the Woods Hole Biological Station.

Electrical shocks were being experienced from a tank in Room 112 (see Figure 3A and 3B). Upon investigating the source of trouble it was found that a potential of 50 volts alternating current (50 V.A.C.) existed between the salt water tank (A) and ground (B). A potential of 25 V.A.C. was found in the same supply line in the tank room (C). Tracing the voltage in the opposite direction isolated the source to Room 111, point (D). A defective immersion type heater element had corroded at a brazed seam allowing water to penetrate the housing. The heater had not been properly grounded through a low resistance, therefore an electric current entered the salt water line at point (D). When water was not being drawn into the tank in Room 11, the circuit was broken and no current flowed.

Because some water was flowing from the tank (A) in Room 112 to the drain (electric ground), a low resistance path equal to approximately 200 ohms existed. Therefore, the electric current passing through the shocked person's dry body was not dangerous to life (see Table 2). Normal dry skin affords a comparatively high resistance which allows only a small amount of current to flow through the body. However, the resistance of wet skin allows thousands of times more current to flow. The path of electric current through the body is vitally important. Current

flowing from one finger to another on the same hand would not pass through vital organs, such as a current passing from one hand to the other hand.

Safeguard Methods

A study was initiated to determine a method of effectively grounding any electricity which may accidentally become exposed to a part of the system. In order to safeguard against shock hazards the following should be done:

1. All electrical tools, appliances, instruments, especially those used in experimental tanks, i.e., immersion heaters, stirrers, metal cooling coils, electrodes for sensing oxygen, salinity, pH, etc., must be properly grounded. If the insulation in electrical equipment should break down, the frame and other metal parts of that equipment becomes energized. If a properly grounded wire is connected to the frame, the electrical current will follow the wire which is the path of least resistance.

Determine whether the electrical wiring is the three wire type or two wire type. New buildings, in accordance with the national electric code, have three wires, one of which is a ground to drain off potential shocks. This type is compatible with appliances having three prong plugs.

In a two wire system install a single conductor number 18 copper wire to all appliances and attach it to a screw on the appliance. Then attach the other end of the ground wire to the grounded outlet box. Caution: Attach the ground wire before inserting the plug in the outlet.

2. A method must be used to ground the salt water system without the use of toxic metals which would defeat the intended purpose of plastics. A study was made of materials which would meet the following requirements:

- (1) High corrosion resistance.

(2) Low electrical contact resistance.

(3) Freedom from fouling.

Graphite, titanium, and platinized titanium were selected after making a study of available materials. All of these materials are at the most noble (least corrosive) end of the galvanic series of Tables 5 and 6.

Samples of the above were placed in isolated tanks containing fish for a period of over three months. No toxic effects to the fish were apparent and no corrosion or pitting of the materials occurred.

ELECTRODE INSTALLATION

The 4 inch synthetic rubber pipe used throughout the Woods Hole system is tapped on the sidewall (see Figure 4) to accommodate stopcocks. A foam rubber material covers the piping for the purpose of eliminating water drippage. The tapped holes are 5/8 of an inch in diameter and are sealed with plastic plugs where stopcocks are not used.

The graphite rod used was National Carbon grade AGSR, #P2718. It was 5/16 of an inch x 6 inches and has an electrical resistivity of 8.40×10^{-4} ohms/cm. The titanium rod was 1/4 of an inch x 6 inches and has an electrical resistivity of 5.48×10^{-5} ohms/cm. The plastic plugs were machined to accept the rods and an epoxy resin was used to provide a watertight seal (see Figure 5).

The electrodes were inserted in the plastic supply lines and connected through a #12AWG copper wire and brass clamp to the copper pipe compressed air system which runs parallel to the sea water supply lines throughout the laboratory and aquarium. In other systems connection could be

made to metallic water pipes, steam pipes, or a low resistance source to the earth. Paint and other insulating material should be removed from the surface before attaching the ground clamp.

When using electrical apparatus in experimental tanks, portable probes (see Figure 6) should be suspended into the water and connected through a copper wire and clamp to a suitable ground.

ELECTRODE MAINTENANCE

Regular checks should be made annually to determine the contact resistance between electrodes. If the electrodes have become fouled, they should be thoroughly cleansed before being reinserted. A dilute hydrochloric acid (1 part acid, 3 parts water) is an effective solvent when necessary. Titanium and platinized titanium installed in the Woods Hole system since 1963 and 1965 respectively have shown no sign of corrosion or pitting. Only a small amount of fouling was present and it was easily brushed clean.

FOULING ANALYSIS

Examination of two electric probes removed from the Woods Hole Laboratory sea-water system on 15 March 1966.

General observation: Fouling is light on both probes. It consists of gray material adhering to metal.

No live organisms are visible to the naked eye.

Probe 1: Flat titanium strip covered in places with flaky material and loose sediment. Only about 10-15% of probe surface covered with fouling.

Microscopic examination reveals the following: completely, transparent, colorless scales with dark black particles embedded or attached to them. The black material is in form of irregular stars resembling deposit of sulfides of some heavy metal. Loose grayish sediment consists primarily of a mass of sponge spicules in places corresponding to the configuration of small bodies of live sponges. Spicules of calcareous sponges of the type of *Grantia* and many loose spicules of siliceous sponges are present in abundance. They are covered with organic detritus and give support to numerous sedentary infusoria, probably *Vorticella patellina* which appear to be in healthy condition. Occasional diatoms of the type of *Pleurosigma* and short colonies of *Melosira* were present. Two small live annelids were found: one of the *Terebellidae* and the other of *Sabellidae*. Both specimens too small for species identification. They were building tubes of loose sediment particles and sponge spicules. Small, not identifiable flagellates and infusoria, were occasionally seen.

Probe 2: The platinized titanium rod was covered with light material similar in appearance to that of probe 1. About 60% of probe surface was covered with fouling.

Fouling consisted primarily of loose sponge spicules of calcareous and siliceous sponges mixed with organic detritus. Few bottom diatoms of *Pleurosigma* type were present. Live *Vorticellae* were present.

No annelids were found and the transparent flakes with black particles were absent.

DISCUSSION

An account is given of methods and materials used in the Woods Hole sea-water system to safeguard personnel and fish against electric shock. Table 7 is a summary of the electrical resistivity of electrodes inserted in the sea-water supply lines.

The graphite rods installed in the pipe lines for well over a year have a very low contact resistance which is in part due to the material porosity. While this porosity provides a good ground, it also allows water to reach the clamp and copper wire causing corrosion. A conductive epoxy resin (Eccobond 60) which has a bulk resistivity of 50 ohms/cm and a resistance of less than 1 ohm/3 mils was used to seal the exposed surface of the graphite. This method of sealing is not satisfactory since some corrosion continues to exist.

The titanium rods inserted in the system in February, 1963 have a high contact resistance compared to graphite. Examination of the titanium after being exposed to the salt water line for a two year period showed no apparent corrosion or pitting. However, because it was desirable to improve the contact resistance, samples of platinized titanium were obtained and tested. Titanium by itself has a high electrical resistance because of a tenacious oxide film which forms on the surface preventing metallic ions from migrating into the sea-water. This film, however, also is responsible for the unusually high corrosion resistance of the titanium.

Therefore, by combining the two metals, with a thin coating of platinum on titanium, a low electrical contact resistance is realized without impairing titanium's corrosion resistance.

Platinized titanium rods have been installed in the Woods Hole system for over one year. They are inserted in the supply pipe lines at approximately every 30 feet and one in each room of the main laboratory's first floor.

LITERATURE CITED

Holmes, John F. 1966. Wide Range Flow Meter for Oceanographic Measurements.

Meyer-Waarden, P.F. 1957. Electric Fishing, FAO Fisheries Study No. 7.

Redfield, Alfred. 1948. Characteristics of Sea Water, Corrosion Handbook, Edited by Uhlig. John

Wiley and Son, pp 1111-1122.

_____. 1961. National Industrial Carbon and Graphite Catalog S-5950, National Carbon Company,

270 Park Avenue, N.Y. 17.

_____. ----. Occupational Safety Aid MP-8-0 and MP-9-9, U.S. Department of Labor, Bureau of

Labor Standards, Division of Safety Standards and Services, Washington 25, D.C.

_____. ----. Platinized titanium, Englehard Industries, Newark, N.J.

_____. ----. Titanium metals Handbook for the Chemical Processor, Titanium Metals Corporation of

America, 233 Broadway, New York 7, N.Y.

Table 1. Sea water capacity of Woods Hole system.

Standpipe	50,000 gallons
Aquarium	
Holding tanks	4,000
Exhibit tanks	9,000
Recirculating reserve capacity	13,000
Total aquarium water	26,000 gallons
Total system water	76,000 gallons

Table 2. Body reaction to electric current.

1,000 Milliamperes (ma) = 1 ampere

0.5 to 2 ma – Some sensation

2 to 10 ma – Muscular contraction

5 to 25 ma – Painful shock

20 to 200 ma – Heart convulsions

Over 100 ma – Paralysis of breathing

From Occupational Safety Aid MP-8-0

Table 3. Resistance values in ohms ().

Wet wood – 1,000 to 50,000/foot

#10 copper wire – 1/1,000 feet

Human body

 Dry skin – 100,000 to 500,000

 Perspiring – to 1,000

 In water – to 150

From Occupational Safety Aid MP-9-9

Table 4. Specific resistance* (According to Denzer).

Substance	Ohms/meter
Distilled water	1,000,000
Sea water	0.1
Steel	0.0000001

- Resistance of a water cube of a given size often referred to as conductance which is the reciprocal of resistance. The conductivity of water depends on the ionic composition and temperature.

From Electrical Fishing, FAO

Table 5. Galvanic Series.

Corroded end – least noble

Magnesium

Zinc

Aluminum

Steel

Iron

18-8 Stainless (active)

Lead

Tin

Nickel (active)

Brass

Copper

Monel

Nickel (passive)

Inocel

Chromium – Iron

18-8 Stainless (passive)

Silver

Graphite

Gold

Platinum

Titanium

Protected end – most noble

Figure 1. Diagram of overall salt water system at Woods Hole

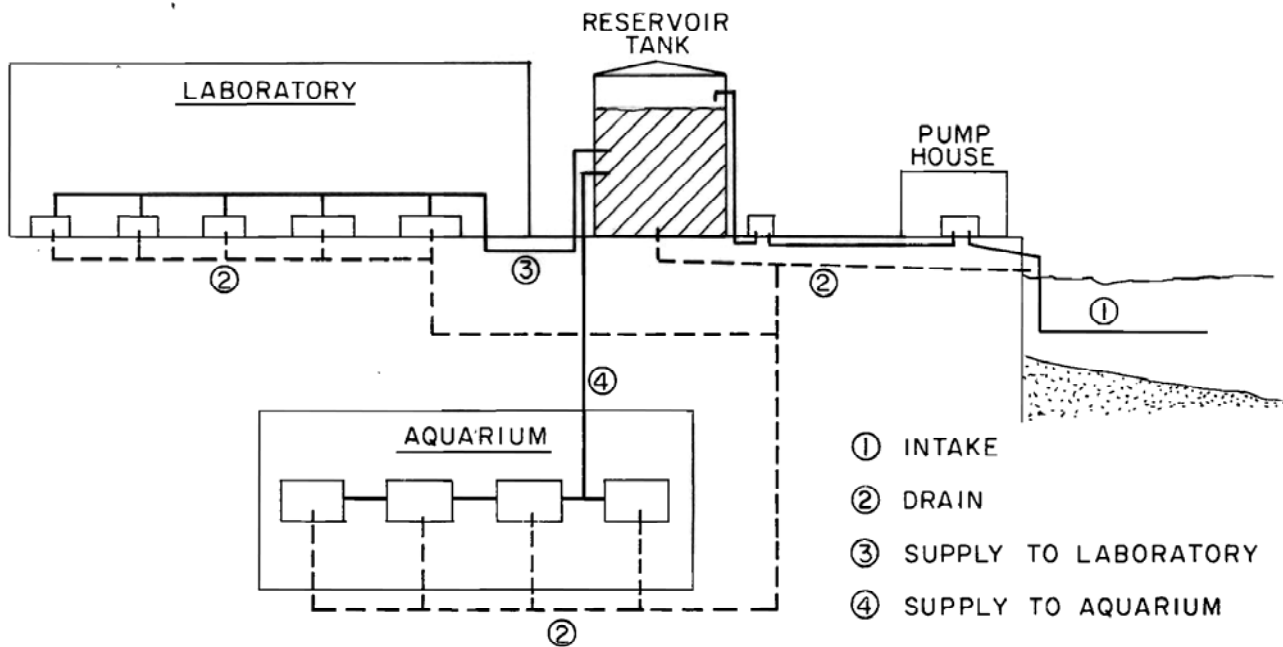

Figure 2. Diagram of salt water reservoir tank at Woods Hole

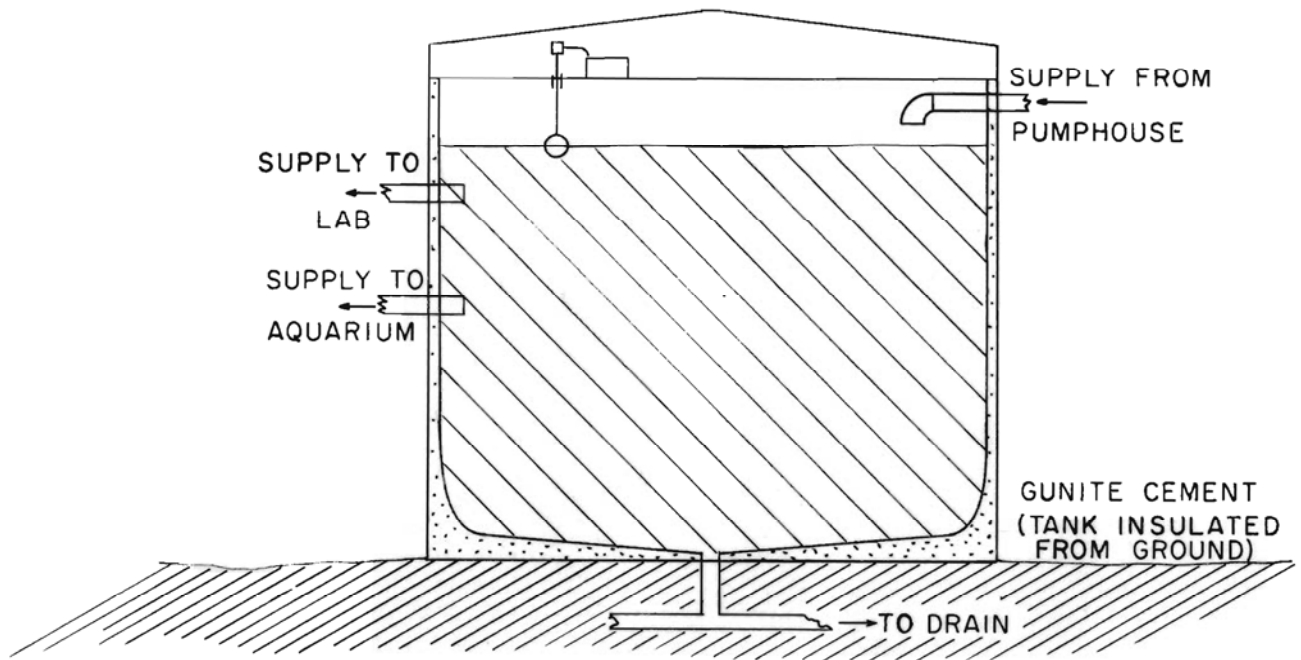

Figure 3. *A*: Diagram of salt water system for first floor of main lab (ocean side) at Woods Hole;
B: Diagram of salt water system for just Room 111 at Woods Hole

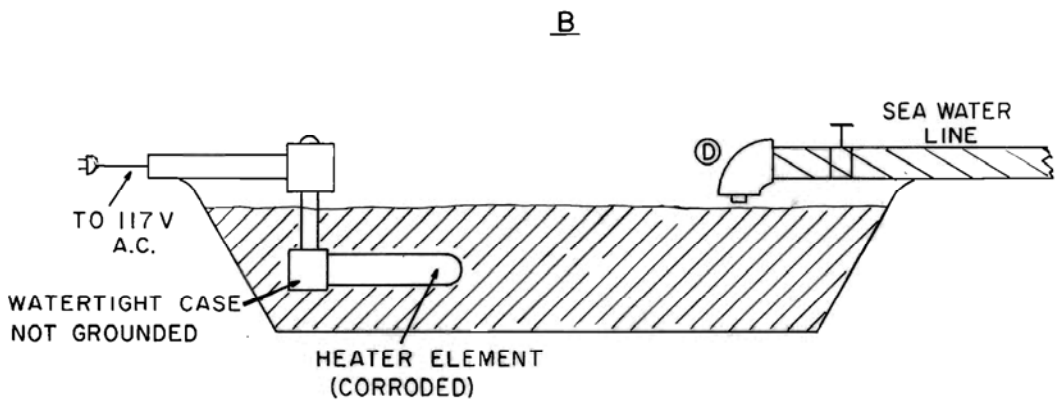
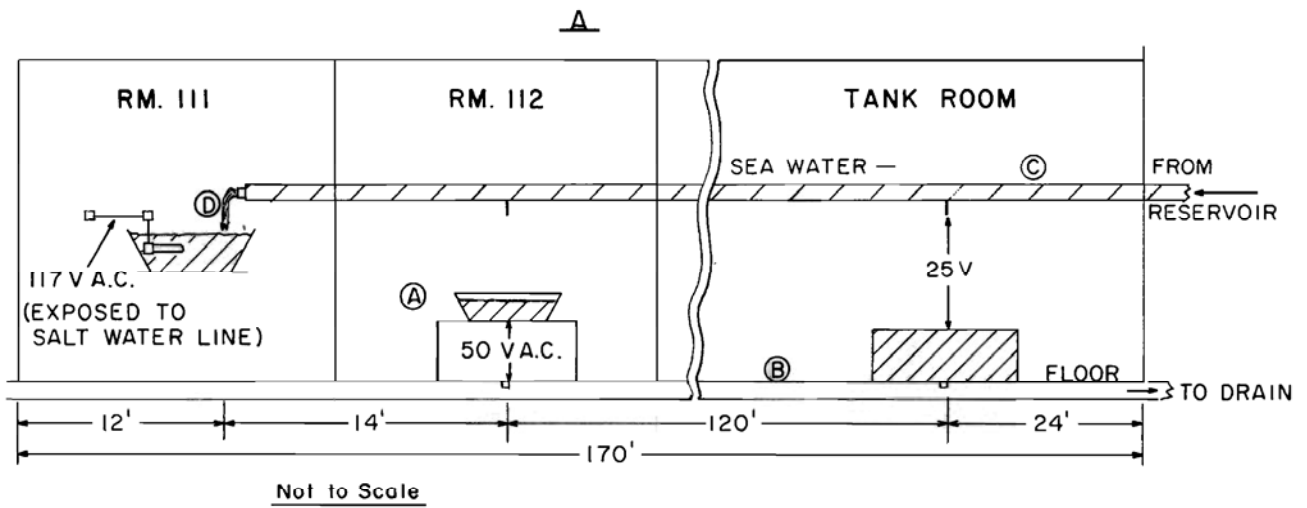

Figure 4. Pipe used throughout Woods Hole system, showing functional electrode setup.

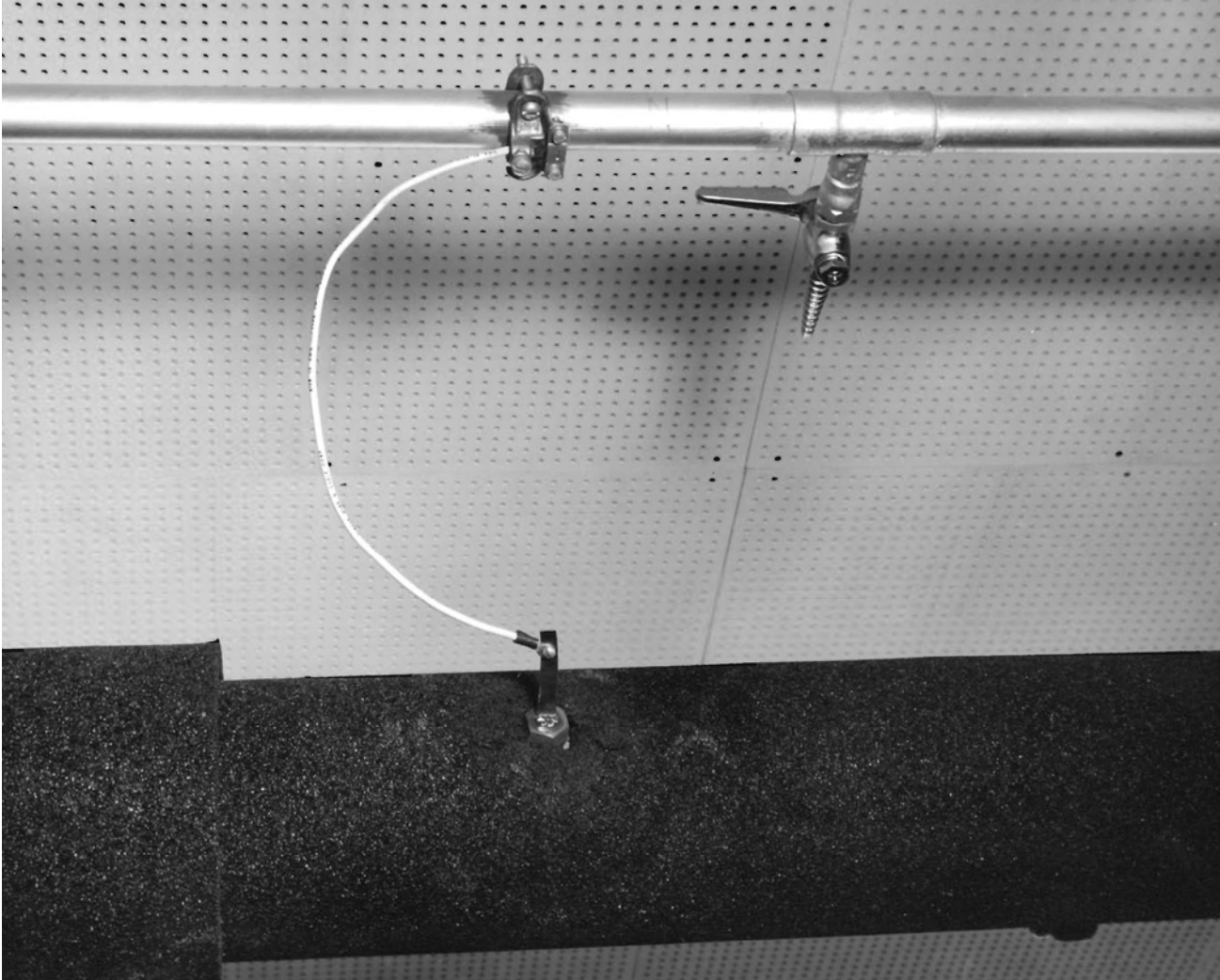

Figure 5. *Top*: Not-yet-machined, 5/8-inch, plastic plug; *Middle*: Not-yet-assembled, 5/16 x 6-inch, graphite electrode; *Bottom*: Assembled, platinized, titanium electrode.

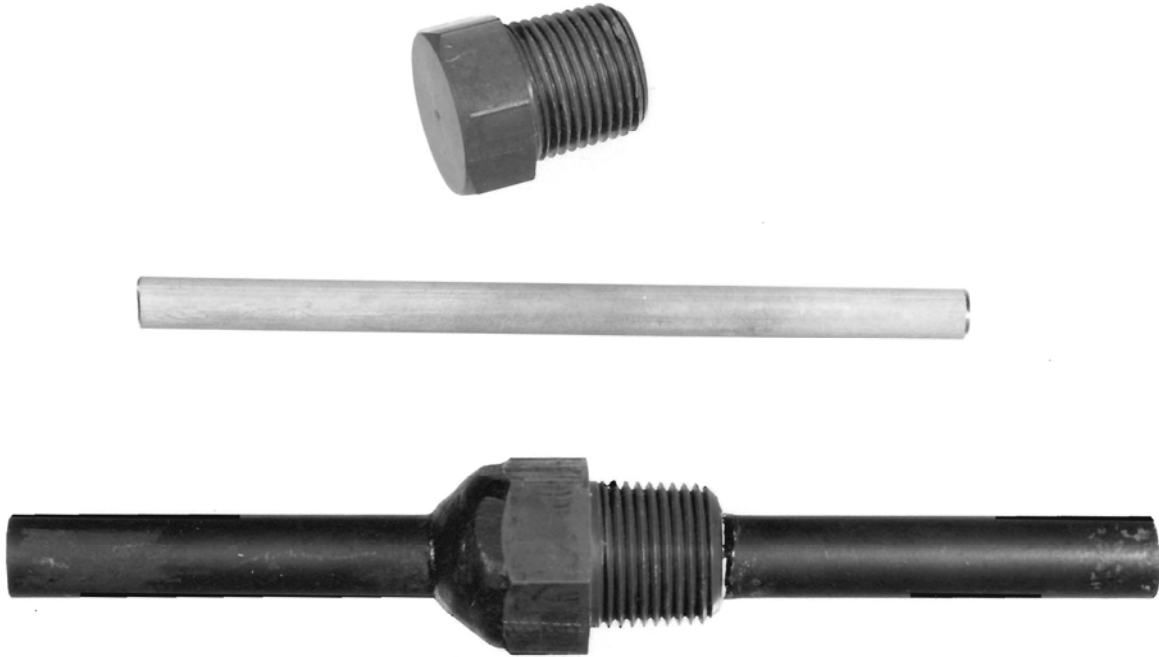
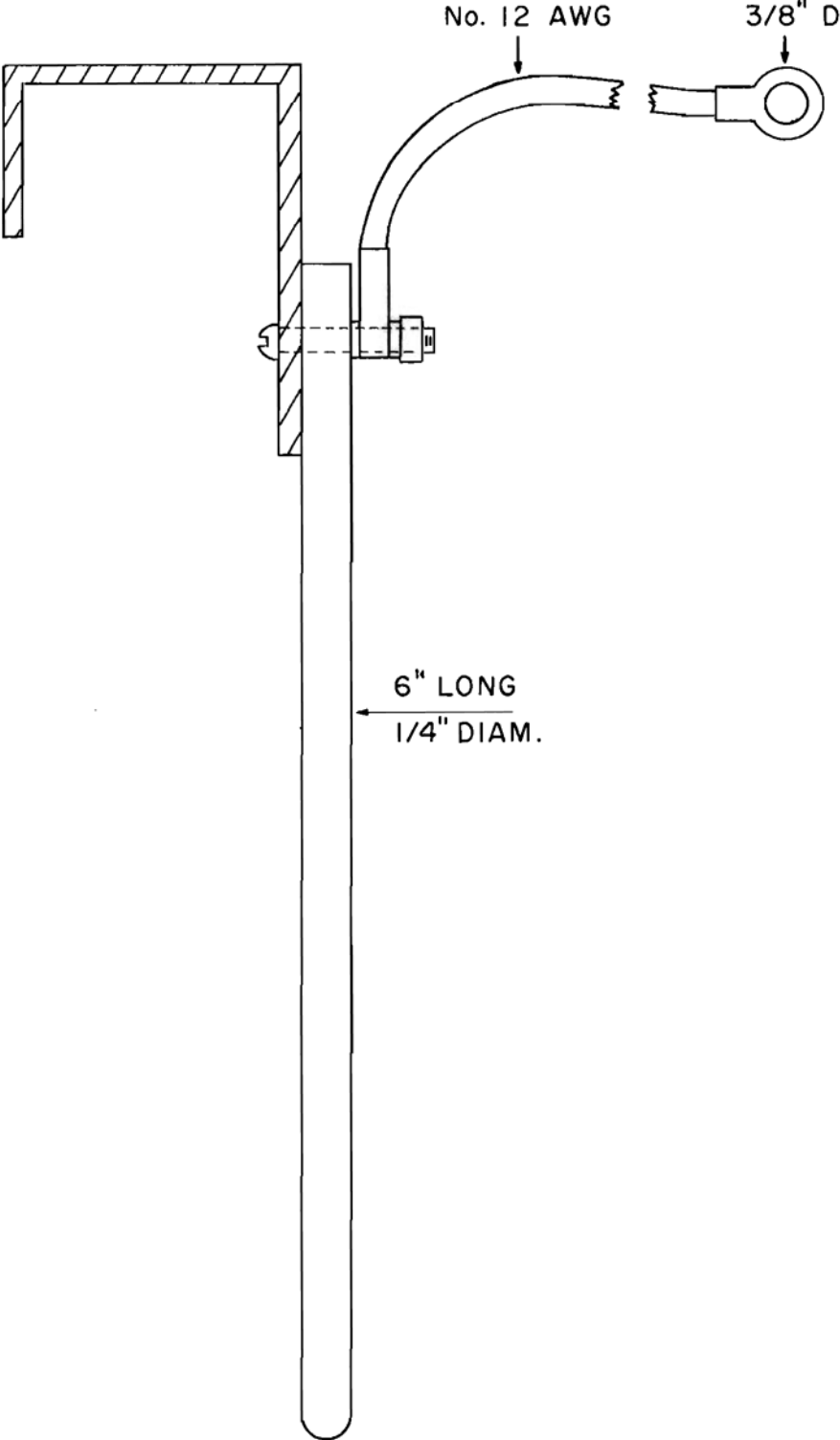

Figure 6. Diagram of portable probe.



Procedures for Issuing Manuscripts in the *Northeast Fisheries Science Center Reference Document (CRD) Series*

Clearance: All manuscripts submitted for issuance as CRDs must have cleared the NEFSC's manuscript/abstract/web-page review process. If any author is not a federal employee, he/she will be required to sign an "NEFSC Release-of-Copyright Form." If your manuscript includes material lifted from another work which has been copyrighted, then you will need to work with the NEFSC's Editorial Office to arrange for permission to use that material by securing release signatures on the "NEFSC Use-of- Copyrighted-Work Permission Form."

Organization: Manuscripts must have an abstract and table of contents, and — if applicable — lists of figures and tables. As much as possible, use traditional scientific manuscript organization for sections: "Introduction," "Study Area"/"Experimental Apparatus," "Methods," "Results," "Discussion" and/or "Conclusions," "Acknowledgments," and "Literature/References Cited."

Style: The CRD series is obligated to conform with the style contained in the current edition of the *United States Government Printing Office Style Manual*. That style manual is silent on many aspects of scientific manuscripts. The CRD series relies more on the *CBE/CSE Style Manual*. Manuscripts should be prepared to conform with these style manuals.

The CRD series uses the American Fisheries Society's guides to names of fishes, mollusks, and decapod crustaceans, the Society for Marine Mammalogy's guide to names of marine mammals, the Biosciences Information Service's guide to serial title abbreviations, and the International Standardization Organization's guide to statistical terms.

For in-text citation, use the name-date system. A special effort should be made to ensure that all necessary bibliographic information is included in the list of cited works. Personal communications must include date, full name, and full mailing address of the contact.

Preparation: The document must be paginated continuously from beginning to end and must have a "Table of Contents." Begin the preliminary pages of the document -- always the "Table of Contents" -- with page "iii." Begin the body of the document -- normally the "Introduction" -- with page "1," and continuously paginate all pages including tables, figures, appendices, and indices. You can insert blank pages as appropriate throughout the document, but account for them in your pagination (*e.g.*, if your last figure ends on an odd-numbered/right-hand page such as "75," and if your next page is the first page of an appendix, then you would normally insert a blank page after the last figure, and paginate the first page of the appendix as "77" to make it begin on an odd-numbered/right-hand page also). Forward the final version to the Editorial Office as both a paper copy and electronically (*i.e.*, e-mail attachment, 3.5-inch floppy disk, high-density zip disk, or CD). For purposes of publishing the CRD series only, the use of Microsoft Word is preferable to the use of Corel WordPerfect.

Production and Distribution: The Editorial Office will develop the inside and outside front covers, the inside and outside back covers, and the title and bibliographic control pages (pages "i" and "ii") of the document, then combine those covers and preliminary pages with the text that you have supplied. The document will then be issued online.

Paper copies of the four covers and two preliminary pages will be sent to the sole/senior NEFSC author should he/she wish to prepare some paper copies of the overall document as well. The Editorial Office will only produce three paper copies (*i.e.*, two copies for the NEFSC's libraries and one copy for its own archives) of the overall document.

A number of organizations and individuals in the Northeast Region will be notified by e-mail of the availability of the online version of the document. The sole/senior NEFSC author of the document will receive a list of those so notified.

Research Communications Branch
Northeast Fisheries Science Center
National Marine Fisheries Service, NOAA
166 Water St.
Woods Hole, MA 02543-1026

**MEDIA
MAIL**

Publications and Reports of the Northeast Fisheries Science Center

The mission of NOAA's National Marine Fisheries Service (NMFS) is "stewardship of living marine resources for the benefit of the nation through their science-based conservation and management and promotion of the health of their environment." As the research arm of the NMFS's Northeast Region, the Northeast Fisheries Science Center (NEFSC) supports the NMFS mission by "conducting ecosystem-based research and assessments of living marine resources, with a focus on the Northeast Shelf, to promote the recovery and long-term sustainability of these resources and to generate social and economic opportunities and benefits from their use." Results of NEFSC research are largely reported in primary scientific media (*e.g.*, anonymously-peer-reviewed scientific journals). However, to assist itself in providing data, information, and advice to its constituents, the NEFSC occasionally releases its results in its own media. Currently, there are three such media:

NOAA Technical Memorandum NMFS-NE -- This series is issued irregularly. The series typically includes: data reports of long-term field or lab studies of important species or habitats; synthesis reports for important species or habitats; annual reports of overall assessment or monitoring programs; manuals describing program-wide surveying or experimental techniques; literature surveys of important species or habitat topics; proceedings and collected papers of scientific meetings; and indexed and/or annotated bibliographies. All issues receive internal scientific review and most issues receive technical and copy editing.

Northeast Fisheries Science Center Reference Document -- This series is issued irregularly. The series typically includes: data reports on field and lab studies; progress reports on experiments, monitoring, and assessments; background papers for, collected abstracts of, and/or summary reports of scientific meetings; and simple bibliographies. Issues receive internal scientific review, but no technical or copy editing.

Resource Survey Report (formerly *Fishermen's Report*) -- This information report is a quick-turnaround report on the distribution and relative abundance of selected living marine resources as derived from each of the NEFSC's periodic research vessel surveys of the Northeast's continental shelf. There is no scientific review, nor any technical or copy editing, of this report.

OBTAINING A COPY: To obtain a copy of a *NOAA Technical Memorandum NMFS-NE* or a *Northeast Fisheries Science Center Reference Document*, or to subscribe to the *Resource Survey Report*, either contact the NEFSC Editorial Office (166 Water St., Woods Hole, MA 02543-1026; 508-495-2350) or consult the NEFSC webpage on "Reports and Publications" (<http://www.nefsc.noaa.gov/nefsc/publications/>).

ANY USE OF TRADE OR BRAND NAMES IN ANY NEFSC PUBLICATION OR REPORT DOES NOT IMPLY ENDORSEMENT.