

MOX Fresh Fuel Package 2nd NRC Meeting

NRC Docket No. 71-9295
October 4, 2000

 PACTEC
PROJECT MANAGEMENT & CONSULTING

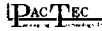

DUKE COLEMAN
STORE & HANLEY

Agenda

- Introduction
- Design Overview
- Preliminary Criticality Analysis Results
- Preliminary Thermal Analysis Results
- Preliminary Structural Analysis Results
- Planned Schedule

 PACTEC
PROJECT MANAGEMENT & CONSULTING

October 4, 2000

MOX Fresh Fuel Package

Page 1



Introduction

- Purpose
 - Update NRC SFPO
 - Present status of the MOX fresh fuel package (MFFP) design
 - Obtain NRC views of:
 - Design approach
 - Preliminary analysis results
 - Certification test plan



Introduction

- Background
 - Excess plutonium (PU) from various DOE defense programs
 - Consortium of Duke, COGEMA, & Stone & Webster (DCS) awarded contract by DOE-MD (Materials Disposition) to design, license and build:
 - MOX fuel fabrication facility (MFFF)
 - MOX PWR fuel assemblies
 - Transportation packages (MFFP)
 - Fuel fabrication facility & transportation package to be NRC-licensed
 - Fuel to be transported between MFFF and mission reactors by DOE using Safeguards Transport (SGT) Vehicles



Design Overview

- Design Overview
 - System Overview
 - Containment Boundary
 - Impact Limiters
 - Payload (Strongback and MOX Fuel Assemblies)



Design Overview

- General Configuration:
 - Overall Envelope Parameters (Approx.)
 - Length: **174.5 inches** (w/o impact limiters)
 - Containment Shell Outer Diameter: **29⁵/₈ inches**
 - Impact Limiter Outer Diameter: **60 inches**
 - Package Gross Weight: **14,500 pounds (15,000 Maximum)**
 - Weight of Internals (strongback, support discs, fuel assemblies): **7,100 pounds**



TRUCK SYSTEMS
ENGINEERING & MANUFACTURE

Design Overview

- General Configuration:
 - Type B(U)F-85 packaging
 - Single containment boundary per 10 CFR §71.63(b)(1)

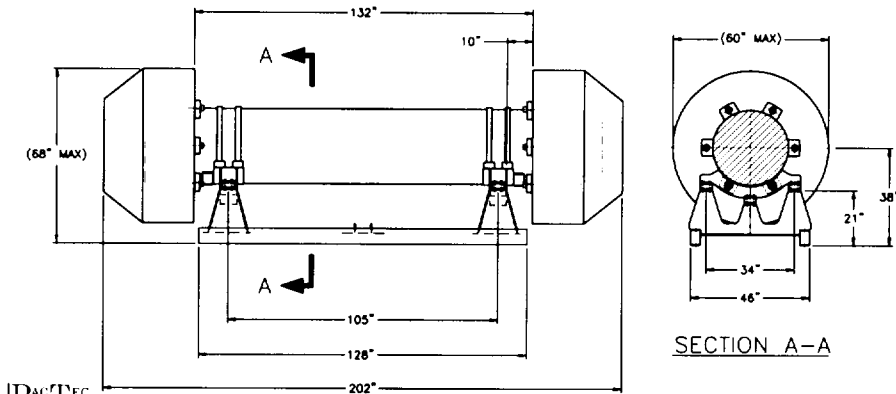

IPAC/TEC

October 4, 2000

MOX Fresh Fuel Package

Page 6



TRUCK SYSTEMS
ENGINEERING & MANUFACTURE

Design Overview

- General Configuration:
 - Cylindrical containment shell with conventional, polyurethane foam filled impact limiters at each end

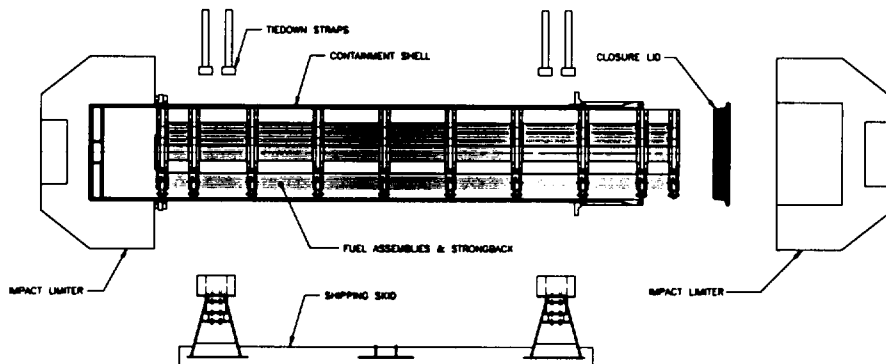

IPAC/TEC

October 4, 2000

MOX Fresh Fuel Package

Page 7



Design Overview

- **Containment Boundary:**
 - Cylindrical, high strength stainless steel shell, reinforced flat ends, and a bolted closure lid at one end
 - Leaktight containment boundary (shell, inner bottom plate, closure lid, and seals)

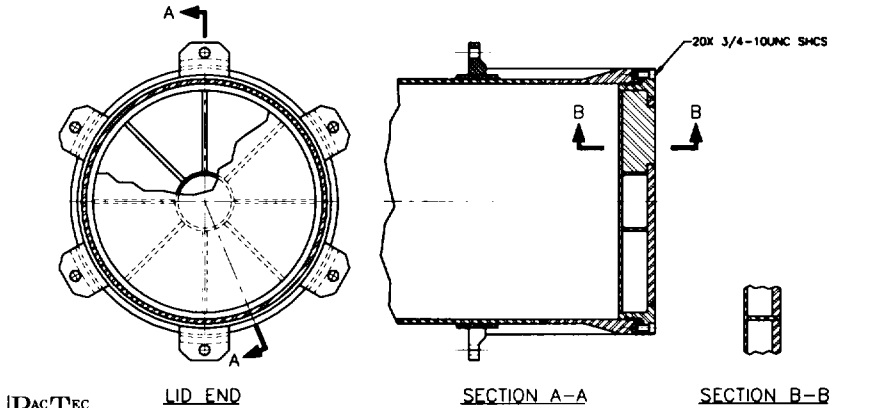

PAC TEC

October 4, 2000

MOX Fresh Fuel Package

Page 8



Design Overview

- **Impact Limiters - Top Impact Limiter**
 - In addition to limiting impact forces, is designed to resist puncture

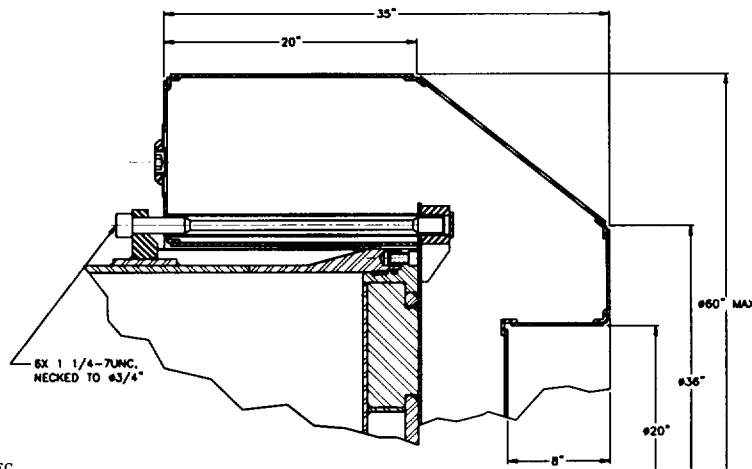

PAC TEC

October 4, 2000

MOX Fresh Fuel Package

Page 9