

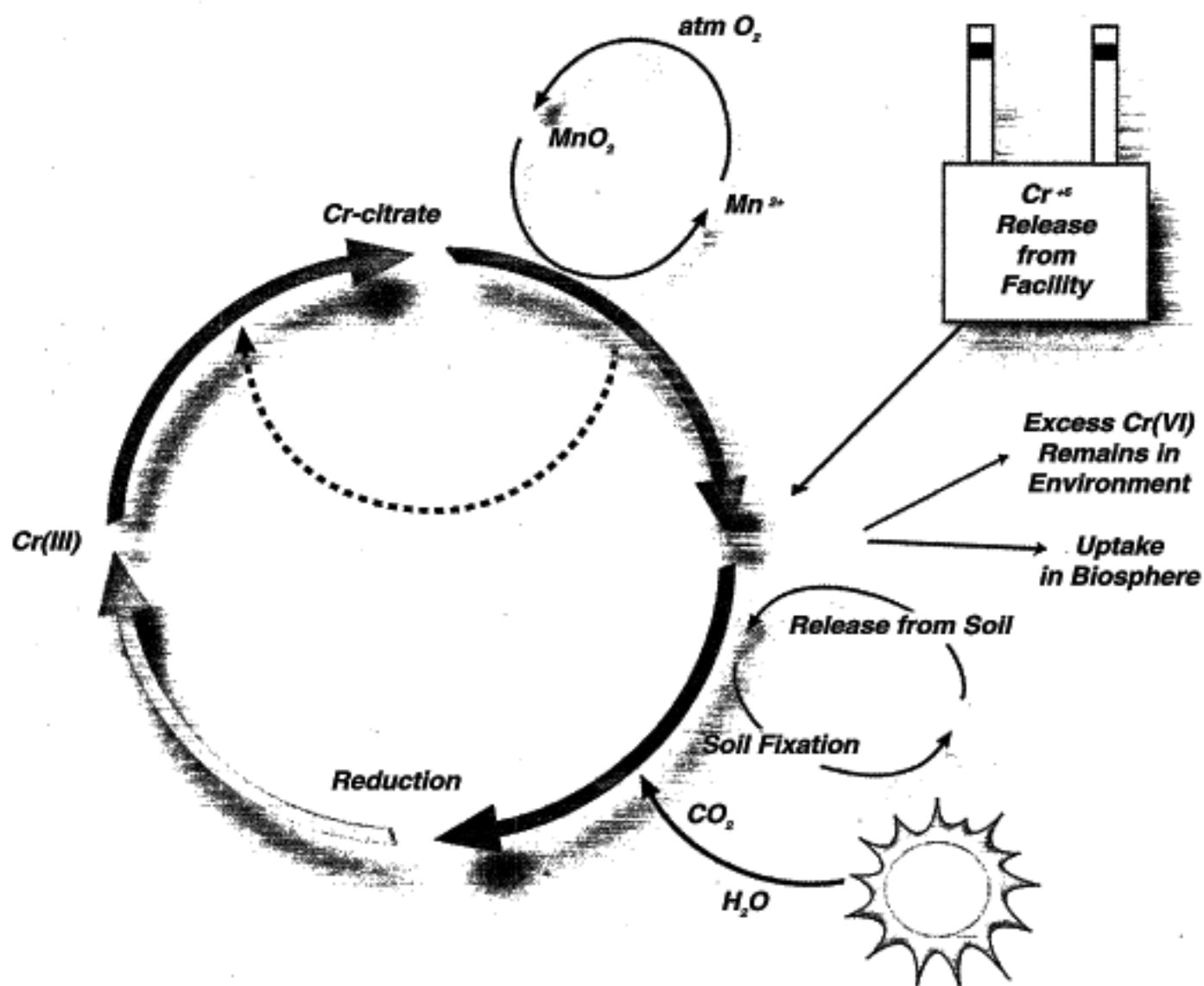

# *In Situ* Treatment of Soil and Groundwater Contaminated with Chromium

## Technical Resource Guide



***IN SITU* TREATMENT OF SOIL  
AND GROUNDWATER  
CONTAMINATED WITH CHROMIUM  
  
TECHNICAL RESOURCE GUIDE**

**Center for Environmental Research Information  
National Risk Management Research Laboratory  
Office of Research and Development  
U.S. Environmental Protection Agency  
Cincinnati, Ohio 45268**

## **Notice**

The U.S. Environmental Protection Agency through its Office of Research and Development funded and managed the research described here under Contract No. 68-C7-0011, Work Assignment 27, to Science Applications International Corporation (SAIC). It has been subjected to the Agency's peer and administrative review and has been approved for publication as an EPA document. Mention of trade names or commercial products does not constitute endorsement or recommendation for use.

## Foreward

The U.S. Environmental Protection Agency is charged by Congress with protecting the Nation's land, air, and water resources. Under a mandate of national environmental laws, the Agency strives to formulate and implement actions leading to a compatible balance between human activities and the ability of natural systems to support and nurture life. To meet this mandate, EPA's research program is providing data and technical support for solving environmental problems today and building a science knowledge base necessary to manage our ecological resources wisely, understand how pollutants affect our health, and prevent or reduce environmental risks in the future.

The National Risk Management Research Laboratory is the Agency's center for investigation of technological and management approaches for reducing risks from threats to human health and the environment. The focus of the Laboratory's research program is on methods for the prevention and control of pollution to air, land, water and subsurface resources; protection of water quality in public water systems; remediation of contaminated sites and ground water; and prevention and control of indoor air pollution. The goal of this research effort is to catalyze development and implementation of innovative, cost-effective environmental technologies; develop scientific and engineering information needed by EPA to support regulatory and policy decisions; and provide technical support and information transfer to ensure effective implementation of environmental regulations and strategies.

This publication has been produced as part of the Laboratory's strategic long-term research plan. It is published and made available by EPA's Office of Research and Development to assist the user community and to link researchers with their clients.

E. Timothy Oppelt, Director  
National Risk Management Research Laboratory

## Abstract

Chromium is the second most common metal found at sites for which Records of Decision have been signed. At many industrial and waste disposal locations, chromium has been released to the environment via leakage and poor storage during manufacturing or improper disposal practices. Industrial applications most commonly use chromium in the hexavalent chromium [Cr(VI)] form, which is acutely toxic and very mobile in groundwater. Groundwater extraction and treatment has traditionally been used to remediate chromium-contaminant plumes. This method, while providing interception and hydraulic containment of the plume, may require long-term application to meet Cr(VI) remediation goals and may not be effective at remediating source-zone Cr(VI).

New information and treatment approaches have been developed for chromium-contaminated soil and groundwater treatment. The purpose of this report is to bring together the most current information pertaining to the science of chromium contamination and the *in situ* treatment and control of sites with groundwater and/or soil contaminated with chromium. A number of available *in situ* technologies or treatment approaches use chemical reduction and fixation for chromium remediation. These include geochemical fixation, permeable reactive barriers (PRBs), and reactive zones. Other types of *in situ* treatment that are under development include enhanced extraction, electrokinetics, biological processes that can be used within PRBs and reactive zones, natural attenuation, and phytoremediation.

Detailed discussions of these *in situ* technologies are contained in the report. Each discussion consists of a technology description with its advantages and disadvantages, status, and performance and cost data. A comparative summary of the status of the technologies is presented in Table 3-1. More conventional *ex situ* approaches and other proven and well-documented technologies for chromium treatment or control are not reviewed within this report. The emphasis in this report is on innovative *in situ* approaches for chromium remediation that are not as well documented, but have been demonstrated or are being developed.

It should be noted that this report is not a design document, but a resource guide. Although it does contain design and cost information, it is primarily intended to enable concerned parties, regulators, scientists, and engineers to evaluate the potential use of various treatment technologies, or combinations of these technologies, to clean up chromium-contaminated sites effectively.

## Table of Contents

<u>Section</u>	<u>Page</u>
Notice .....	i
Foreward .....	ii
Abstract .....	iii
Figures .....	vi
Tables .....	vii
Acronyms, Abbreviations, and Symbols .....	viii
Acknowledgments .....	xi
<b>1 – INTRODUCTION</b>	
1.1 Purpose .....	1
1.2 Background and Regulatory Overview .....	1
1.3 Scope of the Guide .....	3
<b>2 – CHROMIUM IN THE ENVIRONMENT</b>	4
2.1 Sources and Extent of Contamination .....	4
2.2 Chromium Chemistry .....	5
2.3 Chromium Treatment and Remediation Approaches .....	11
2.4 Site Characterization Requirements .....	14
<b>3 – TECHNOLOGIES FOR <i>IN SITU</i> TREATMENT</b>	17
3.1 Geochemical Fixation .....	20
3.1.1 Technology Description .....	20
3.1.2 Status .....	23
3.1.3 Performance and Cost Data .....	23
3.2 Permeable Reactive Subsurface Barriers (Treatment Walls) .....	30
3.2.1 Technology Description .....	30
3.2.2 Status .....	36
3.2.3 Performance and Cost Data .....	38
3.3 Reactive Zones .....	44
3.3.1 Technology Description .....	44
3.3.2 Status .....	52
3.3.3 Performance and Cost Data .....	52
3.4 Soil Flushing/Chromium Extraction .....	56
3.4.1 Technology Description .....	56
3.4.2 Status .....	59
3.4.3 Performance and Cost Data .....	59
3.5 Electrokinetics .....	61
3.5.1 Technology Description .....	61
3.5.2 Status .....	64
3.5.3 Performance and Cost Data .....	65
3.6 Natural Attenuation .....	66

**TABLE OF CONTENTS (continued)**

<b><u>Section</u></b>	<b><u>Page</u></b>
3.6.1 Technology Description .....	66
3.6.2 Status .....	69
3.6.3 Performance and Cost Data .....	69
3.7 Phytoremediation .....	70
3.7.1 Technology Description .....	70
3.7.2 Status .....	70
3.7.3 Performance and Cost Data .....	70
<b>4 – REFERENCES</b> .....	71
<b><u>Appendix</u></b>	<b><u>Page</u></b>
<b>A – SOURCES OF ADDITIONAL INFORMATION</b> .....	77
<b>B – TECHNOLOGY AND VENDOR CONTACT INFORMATION</b> .....	82

## LIST OF FIGURES

<u>Figure</u>		<u>Page</u>
2-1	Metals Most Commonly Present in all Matrices at Superfund Sites . . . . .	4
2-2	Eh-pH Diagram for Chromium . . . . .	6
2-3	The Chromium Cycle in the Environment . . . . .	7
2-4	Chromium Reduction and Fixation . . . . .	11
2-5	Concentration Versus Pumping Duration or Volume Showing Tailing and Rebound Effects (Cohen et al., 1994) . . . . .	12
2-6	Conceptual Geochemical Model of Zones in a Contaminant Plume . . . . .	13
3-1	Schematic of <i>In Situ</i> Chromium Remediation . . . . .	21
3-2	Plot of Hexavalent Chromium Contaminant Plume at the Valley Wood Preserving Site - January, 1998 . . . . .	25
3-3	Plot of Hexavalent Chromium Contaminant Plume at the Valley Wood Preserving Site - November, 1999 . . . . .	26
3-4a	Plume Capture by a Funnel and-Gate System. Sheet Piling Funnel Direct the Plume Through the Reactive Gate. . . . .	32
3-4b	Plume Capture by a Continuous Trench System. The Plume Moves Unimpeded Through the Reactive Gate. . . . .	32
3-5	Breakdown of Inorganic Contaminants Addressed by PRBs . . . . .	37
3-6	Breakdown of Types of PRB Projects Addressing Chromium Remediation . . . . .	37
3-7	ISRM Treatment System Diagram . . . . .	42
3-8	<i>In Situ</i> Reactive Zones Curtain Design Concept . . . . .	46
3-9	Gravity Feed of Reagents When the Contamination is Shallow . . . . .	49
3-10	Multiple Cluster Injection Points When Contamination is Deep . . . . .	49
3-11	Schematic of Molasses-based Injection System at Central Pennsylvania Site	54
3-12	Plot of Hexavalent Chromium Contaminant Plume at Central Pennsylvania Site - January, 1997 . . . . .	55
3-13	Plot of Hexavalent Chromium Contaminant Plume at Central Pennsylvania Site - July, 1998 . . . . .	55
3-14	Schematic of <i>In Situ</i> Flushing System . . . . .	57
3-15	Electrokinetic Remediation Process . . . . .	62



**LIST OF TABLES**

<b><u>Table</u></b>		<b><u>Page</u></b>
1-1	Cleanup Goals (Actual and Potential) for Total and Leachable Metals . . .	2
2-1	Cation Exchange Capacities for Soils – Components and Types . . . . .	9
2-2	Recommended Analytical Methods . . . . .	15
3-1	Status of <i>In Situ</i> Technologies for Treatment of Chromium Contamination	18
3-2	Total Chromium Concentrations (mg/L) of Paired-Column Effluent as a Function of Throughput . . . . .	24
3-3	Comparison of Granular vs. Foam Iron Reactive Media for PRBs . . . . .	35
3-4	Impacts of Various Geologic/Hydrogeologic Parameters on the Design of an <i>In Situ</i> Reactive Zone . . . . .	48
3-5	Results of Cr(VI) Extraction Studies by Surfactants and Hydrotropes from Elizabeth City Soil . . . . .	60
3-6	Cr(VI) Extraction From Columns by Water, Surfactants Alone, and Surfactant Solubilized DPC . . . . .	61
3-7	Case Studies from GII . . . . .	65

## Acronyms, Abbreviations, and Symbols

(aq)	aqueous
(s)	solid
<	less than
>	greater than
AEC	anion exchange capacity
BaCrO <sub>4</sub>	barium chromate
BDAT	Best Demonstrated Available Technology
Ca	calcium
CaCO <sub>3</sub>	calcium carbonate
CCA	copper chromium arsenate
Cd	cadmium
CEC	cation exchange capacity
CERCLA	Comprehensive Environmental Response, Compensation, and Liability Act
CH <sub>4</sub>	methane
Cl	chloride
cm	centimeter
CMC	critical micelle concentration
CN	cyanide
Co	cobalt
CO <sub>2</sub>	carbon dioxide
Cr	chromium
Cr(III)	trivalent chromium (reduced form)
Cr(VI)	hexavalent chromium (oxidized form)
Cr <sub>2</sub> O <sub>7</sub> <sup>-2</sup>	dichromate
CrO <sub>4</sub> <sup>-2</sup>	chromate
CrOH <sub>x</sub>	chromium hydroxide (numerous species)
Cu	copper
DI	deionized
DMRB	dissimilatory metal-reducing bacteria
DOC	dissolved organic carbon
DOE	U.S. Department of Energy
DPC	diphenyl carbazide
Eh	redox potential
EIX	electrochemical ion-exchange
EPA	U.S. Environmental Protection Agency
Fe	iron
Fe(II)	ferrous iron (reduced form)
Fe(III)	ferric iron (oxidized form)
Fe <sup>0</sup>	zero-valent iron
ft	foot
ft <sup>2</sup>	square foot
ft <sup>3</sup>	cubic foot
g	grams
H <sub>2</sub>	hydrogen
HCrO <sub>4</sub>	hydrochromate
HSO <sub>3</sub> <sup>-</sup>	hydrosulfite
ICP/AES	Inductively coupled plasma/atomic emission spectrometry
ICP/MS	Inductively coupled plasma/mass spectrometry

## Acronyms, Abbreviations, and Symbols (Continued)

in	inch
ISEE	<i>In Situ</i> Electrokinetic Extraction
ISRM	<i>In Situ</i> Redox Manipulation
kg/m <sup>3</sup>	kilogram per cubic meter
kW-hr/m <sup>3</sup>	kilowatt-hour per cubic meter
kWh	kilowatt-hour
L/min	liter per minute
lbs/ft <sup>3</sup>	pounds per cubic foot
<i>M</i>	molar
m	meter
m <sup>2</sup> /ft <sup>3</sup>	square meters per cubic foot
m <sup>2</sup> /g	square meters per gram
m <sup>2</sup> /\$	square meters per dollar
MCL	maximum contaminant level
meg	milli equivalent
mg/kg	milligram per kilogram
mg/L	milligram per liter
mg/h	milligram per hour
<i>mM</i>	millimolar
mmol/L	millimole per liter
Mn	manganese
MnO	manganese oxide
MnO <sub>2</sub>	manganese dioxide
mV	milli-volt
N <sub>2</sub>	nitrogen
Ni	nickel
NO <sub>2</sub> <sup>-1</sup>	nitrite
NO <sub>3</sub> <sup>-1</sup>	nitrate
NPL	National Priorities List
O&M	Operation and Maintenance
OH	hydroxide
OSC	On-Scene Coordinator
Pb	lead
PBAT	Permeable Barriers Action Team
pH	negative log <sub>10</sub> of hydrogen ion concentration
PLC	programmable logic controller
PO <sub>4</sub> <sup>-3</sup>	phosphate
ppb	parts per billion
PRB	permeable reactive barrier
RCRA	Resource Conservation and Recovery Act
ROD	Record of Decision
ROOH	organic acid
RPM	Remedial Project Manager
RTDF	Remediation Technologies Development Forum
S	sulfur
S <sub>2</sub> O <sub>6</sub> <sup>-2</sup>	metabisulfite
SDL	Sandia National Laboratories
Se	selenium
SITE	Superfund Innovative Technology Evaluation

## Acronyms, Abbreviations, and Symbols (Continued)

SMZ	surfactant-modified zeolite
SO <sub>4</sub> <sup>-2</sup>	sulfate
TCE	trichloroethene
TCLP	Toxicity Characteristic Leaching Procedure
TOC	total organic carbon
µg/L	microgram per liter
USCG	U.S. Coast Guard
WET	Waste Extraction Test
yd <sup>3</sup>	cubic yard
Zn	zinc
ZVI	zero-valent iron

## **Acknowledgments**

This Technical Resource Guide was prepared under the direction and coordination of Mr. Douglas Grosse of the U.S. Environmental Protection Agency (EPA) National Risk Management Research Laboratory (NRMRL) in Cincinnati, Ohio. Mr. Grosse served as the project officer. Contributors to and reviewers of this Guide were Mr. Grosse; Ms. Marta Richards of NRMRL; Dr. Robert Puls of NRMRL, Ada, Oklahoma; Mr. Ralph Howard, EPA Region IV RPM; Dr. Andy Davis of Geomega, Inc.; Mr. Ishwar Murarka of Ish, Inc.; and Mr. Jim Rouse of Montgomery Watson. Ms. Jean Dye of NRMRL provided final editorial review, and Mr. John McCready of NRMRL designed the cover.

This Guide was prepared for the EPA NRMRL by Mr. Kyle Cook, Mr. Robert Sims, Ms. Allison Harten, and Mr. John Pacetti of Science Applications International Corporation (SAIC). Kyle Cook was the SAIC Work Assignment Manager. Special thanks is given to Ms. Debbie Seibel, Ms. Christina Hudson, Ms. Elizabeth Wunderlich, and Mr. Richard Dzija of SAIC for their administrative and technical assistance in preparing this Guide.

# Section 1

## INTRODUCTION

### 1.1 Purpose

Contamination of soil and groundwater by chromium is a significant problem in the United States. Conventional groundwater treatment approaches such as pumping and *ex situ* treatment have been used to address this problem. The poor performance of pump-and-treat systems in the mid-1980s provided the driving force for research of subsurface processes in order to develop more efficient groundwater remediation strategies and techniques. As a result, new information and treatment approaches have been developed for chromium-contaminated soil and groundwater treatment. However, much of this information is either scattered in the literature or not directly available, making it difficult for decision makers to access. The purpose of this document, therefore, is to bring together the most current information pertaining to the science of chromium contamination and the treatment and control of sites with groundwater and/or soil contaminated with it. It is hoped that this information will enable remedial project managers (RPMs); on-scene coordinators (OSCs); state, local, and Indian tribal regulators; technology vendors; consultants; private organizations; and citizens to evaluate the potential use of treatment technologies to clean up chromium-contaminated sites effectively.

### 1.2 Background and Regulatory Overview

Groundwater can become contaminated with metals directly by infiltration of leachate from land disposal of solid wastes, sewage or sewage sludge; leachate from mining wastes; seepage from industrial lagoons; and spills and leaks from industrial metal processing or wood preserving facilities. Numerous waste and site

conditions control and influence the leachability of the metals and wastes and their transport into groundwater (Evanko and Dzombak, 1997).

Several categories of technologies exist for the remediation of metals-contaminated soil and water. These include: isolation, immobilization, toxicity reduction, physical separation, and extraction. Combinations of one or more of these approaches are often used for more efficient and cost-effective treatment of a contaminated site. *In situ* treatment methods for metals-contaminated soil and groundwater are being tested and will be applied with increasing frequency (Evanko and Dzombak, 1997). While a great deal of progress has been made, a number of needs and issues still need to be addressed before *in situ* soil and groundwater remediation technologies will be most effective. For those technologies that have proven successful in field pilot-scale demonstrations, an important next step is to take the technology to a larger scale demonstration and to use it for an actual site remediation. For those technologies that have been implemented at one or a few sites, the next goal is to make them more commonly accepted practices for site remediation. An important part of this transition is the acquisition of credible cost data and the development and evaluation of cost models that can be used for system design (Schmelling, 1999).

Soil and groundwater cleanup goals for chromium (Cr) and other metals can be defined as total and leachable metals. Actual and potential soil cleanup goals for chromium are presented in Table 1-1. Total metals goals are levels that can be applied directly to contaminated soil. There is some variability in these goals for total chromium. The total metals analysis determines the level of metals contamination expressed as mg metal/kg soil. This analysis does not take into consideration

the leachability of the metals contaminants. For leachable metals, the leachate levels are applied to solid wastes such as soil after extracting and testing the material with the specified analytical methods. Leachable metals may be determined by different analytical procedures, as shown in Table 1-1, that measure the concentration of metals expressed in mg/L of the leachable material. The maximum contaminant level (MCL) and Superfund Site Goals are applied to groundwater. The observed variation in cleanup

goals has at least two implications in regard to technology alternative evaluation and selection. First is the importance of identifying the target metals contaminant state (leachable vs. total metal), the specific type of test and conditions, and the numerical cleanup goals early in the remedy evaluation and process. Second, the effectiveness of a technology for meeting total or leachable treatment goals should be viewed with some caution in light of the degree in variation in goals and the many factors that affect mobility of the metals (USEPA, 1997).

**Table 1-1. Cleanup Goals (Actual and Potential) for Total and Leachable Metals**

Description	
<b>Total Metals Goals (mg/kg)</b>	
Background (Mean)	100
Background (Range)	1 to 1000
Superfund Site Goals	6.7 to 375.0
Theoretical Minimum Total Metals to Ensure TCLP <sup>a</sup> Leachate <Threshold (i.e., TCLP x 20)	100
California Total Threshold Limit Concentration	500
<b>Leachable Metals (ug/L)</b>	
TCLP <sup>a</sup> Threshold for RCRA Waste (SW 846, Method 1311)	5000
Extraction Procedure Toxicity Test (EP Tox) (Method 1310)	5000
Synthetic Precipitate Leachate Procedure (Method 1312)	–
Multiple Extraction Procedure (Method 1320)	–
California Soluble Threshold Leachate Concentration	5000
MCL <sup>b</sup>	100
Superfund Site Goals	50

- a TCLP = Toxicity Characteristic Leaching Procedure
- b The maximum permissible level of contaminant in water delivered to any user of a public system.
- No specified level and no example cases identified.

In uncontaminated natural waters, the range of chromium concentrations is quite large. The median value in unpolluted freshwater or seawater is usually low, less than 50  $\mu\text{g/L}$ . For most natural waters, the chromium concentration is below the 50  $\mu\text{g/L}$  value (approximately 1  $\text{mmol/L}$ ) recommended for drinking water by the Commission of European Communities, the World Health Organization, or the U.S. Environmental Protection Agency (Richard and Bourg, 1991). As shown in Table 1-1, the Superfund Site Goal for groundwater is 50  $\mu\text{g/L}$ , and the maximum contaminant level is 100  $\mu\text{g/L}$ .

### 1.3 Scope of the Guide

Section 2 of this Guide provides more background information on the sources of chromium contamination and the extent of the problem in the United States.

Section 2 also presents a detailed examination of chromium chemistry in order to help the reader better understand the behavior of

chromium in the environment, its characterization, and its relationship to treatment approaches.

Section 3 explores the latest *in situ* technological approaches for dealing with chromium site remediation, the emphasis of this Guide. Finally, additional sources of information and studies are listed in Appendices A and B for those interested in acquiring more information.

This document is not intended to be a comprehensive description of *in situ* technological approaches for dealing with chromium site remediation. Rather, it is intended to be used as a resource guide in conjunction with other references, such as those listed in Appendix A, the opinions of technology experts, and site-specific information. Therefore, the reader is cautioned that information provided in this document, including costs, is specific to the study cited, and may not be directly transferable to other applications.



## Section 2

### CHROMIUM IN THE ENVIRONMENT

#### 2.1 Sources and Extent of Contamination

Chromium is an important industrial metal used in diverse products and processes (Nriagu, 1988). At many industrial and waste disposal locations, chromium has been released to the environment via leakage and poor storage during manufacturing or improper disposal practices (Palmer and Wittbrodt, 1991; Calder, 1988). The first instances of groundwater contamination were associated with chromium plating operations at aircraft manufacturing facilities during World War II. Many of these plumes have moved thousands of feet over the past 50 years, with little or no natural attenuation (Rouse, 1997). The National Priority List (NPL) of 1986 developed by the U.S. Environmental Protection Agency (EPA) presents approximately 1,000 sites in the U. S. that pose significant environmental health

risks (Allen et al., 1995).

About 40 percent of these sites have been reported to have metals problems. The majority of these reported metals are combined with organics, but a significant number reported are metals only or metals with inorganics. The metals most often cited as problems are lead, chromium, arsenic, and cadmium. According to EPA data for sites for which Records of Decision (RODs) have been signed, chromium is the second most common metal found at these contaminated sites (U.S. EPA, 1996). Figure 2-1 summarizes the occurrence and distribution of metals at these sites. Currently, the principal sources of chromium-contaminated soils and groundwater are electroplating, textile manufacturing, leather tanning, pigment manufacturing, wood preserving, and chromium waste disposal (U.S. EPA, 1997).

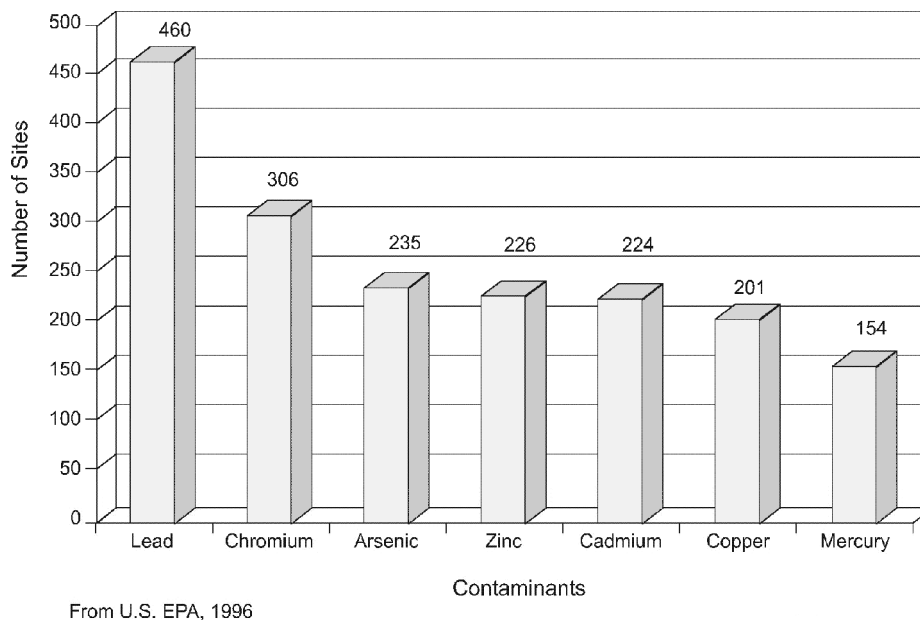

Figure 2-1 Metals most commonly present in all matrices at Superfund sites.

The use of metals in waterborne wood preserving solutions has increased over time, with consumption in 1995 exceeding all other processes combined (AWPI, 1996). By far the most widely used wood preserving formulation is copper chromium arsenate (CCA). Due to operating procedures that were standard practices at the time, nearly all wood preserving plants 20 years or older present some degree of soil and groundwater contamination. At least 71 wood preserving sites have been listed on the Comprehensive Environmental Response, Compensation, and Liability Act (CERCLA) NPL (Federal Register, 1996). At least 678 additional sites exist at which wood preserving operations have been or are currently being conducted; contamination may be present at many of these sites as well (U.S. EPA, 1997c).

The most significant groundwater and soil contamination problem associated with the use of CCA is hexavalent chromium [Cr(VI)] which is acutely toxic, mutagenic, and carcinogenic in the environment. It is also very soluble, mobile, and moves at a rate essentially the same as the groundwater (Palmer and Puls, 1994). In contrast, the reduced form of Cr(VI), trivalent chromium [Cr(III)], has relatively low toxicity and is immobile under moderately alkaline to slightly acidic conditions. Industrial applications most commonly use chromium in the Cr(VI) form, which can introduce high concentrations of oxidized chromium (chromate) into the environment. Cr(VI) does not always readily reduce to Cr(III) and can exist over an extended period of time.

## 2.2 Chromium Chemistry

This section describes the basic chemistry involved with the various oxidation states of

chromium to account for the behavior of this metal in the natural environment, and links this information to *in situ* technologies discussed in the following sections of this Guide.

### ***Aqueous Chemistry and pH Effect***

Chromium has a unique geochemical behavior in natural water systems. Cr(III) is the most common form of naturally occurring chromium, but is largely immobile in the environment, with natural waters having only traces of chromium unless the pH is extremely low. Under strong oxidizing conditions, chromium is present in the Cr(VI) state and persists in anionic form as chromate. Natural chromates are rare. However, the use of Cr(VI) in wood preserving CCA solutions, metal plating facilities, paint manufacturing, leather tanning, and other industrial applications has the potential to introduce high concentrations of oxidized chromium to the environment (Rouse and Pyrih, 1990; Palmer and Wittbrodt, 1991).

Redox potential Eh-pH diagrams present equilibrium data and indicate the oxidation states and chemical forms of the chemical substances which exist within specified Eh and pH ranges. Figure 2-2 is an Eh-pH diagram for chromium. The data presented in Figure 2-2 are derived from parameters representing typical aqueous conditions. Although the diagram implies that the boundary separating one species from another is distinct, the transformation is so clear cut. Concentration, pressure, temperature, and the absence or presence of other aqueous ions can all affect which chromium species will exist. A measure of caution must be exercised when using this diagram as site-specific conditions can significantly alter actual Eh-pH boundaries.

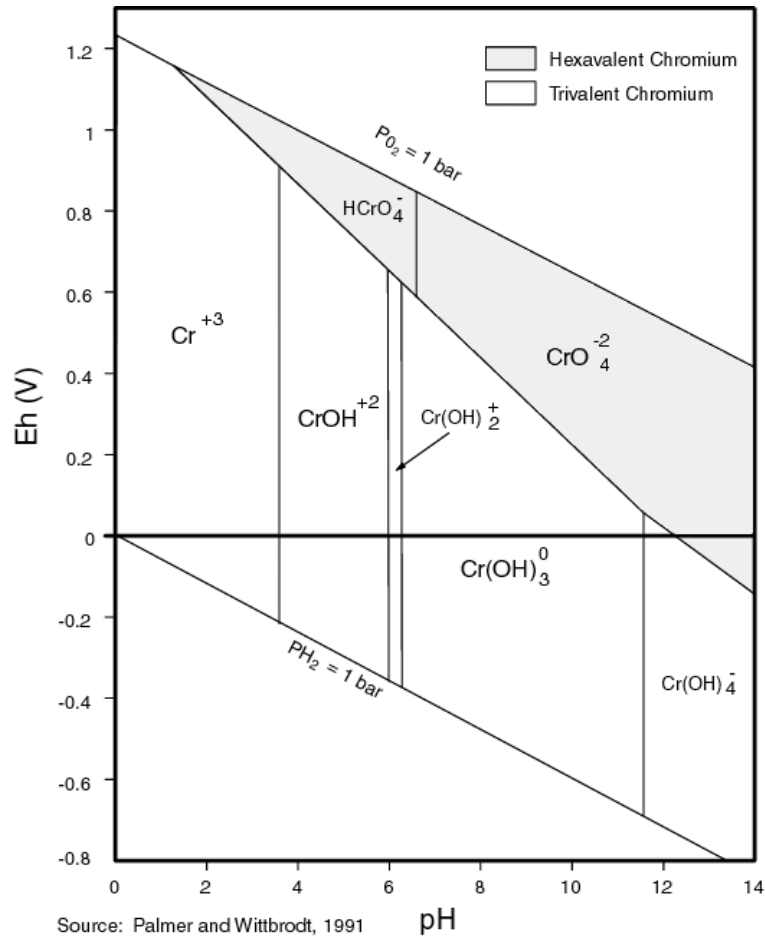

**Figure 2-2 Eh-pH diagram for chromium.**

Palmer and Wittbrodt (1991) claim that chromium exists in several oxidation states ranging from 0 to 6. Under reducing conditions, Cr(III) is the most thermodynamically stable oxidation state. However, Cr(VI) can remain stable for significant periods of time. In soils and aquifer systems, the most prevalent forms are the trivalent and hexavalent oxidation states.

Cr(III) exists in wide Eh and pH ranges. Palmer and Wittbrodt (1991) have determined that the following Cr(III) species exist with respect to pH. Cr(III) predominates as ionic (i.e.,  $Cr^{+3}$ ) at pH values less than 3.0. At pH values above 3.5, hydrolysis of Cr(III) in a Cr(III)-water system yields trivalent chromium hydroxy species

[ $CrOH^{+2}$ ,  $Cr(OH)_2^+$ ,  $Cr(OH)_3^0$ , and  $Cr(OH)_4^-$ ].  $Cr(OH)_3^0$  is the only solid species, existing as an amorphous precipitate. The existence of the  $Cr(OH)_3^0$  species as the primary precipitated product in the process of reducing Cr(VI) to Cr(III) is paramount to the viability of *in situ* treatment using reactive zone technology, such as microbial bioreduction. Cr(III) can form stable, soluble (and thus mobile), organic complexes with low to moderate molecular weight organic acids (i.e., citric and fulvic acids). The significance of these complexes is that they allow Cr(III) to remain in solution at pH levels above which Cr(III) would be expected to precipitate (Bartlett and Kimble, 1976a; and James and Bartlett, 1983a).



The success of geochemical fixation treatment techniques is based on forming insoluble non-reactive chemical species. Precipitation and adsorption result in fixation or solid-phase formation of Cr(III), each depending on the physical and chemical conditions existing in the aquifer system. Precipitation reactions can be further divided into three types: pure solids such as  $\text{Cr}(\text{OH})_3^0$  (amorphous precipitation); mixed solids or coprecipitates such as  $\text{Cr}_x\text{Fe}_{1-x}(\text{OH})_3$ ; and high molecular weight organic acid complexes such as humic acid polymer (Palmer and Wittbrodt, 1991 and James and Bartlett, 1983b). Pure solid Cr(III) hydroxide precipitates result from changes in the Eh-pH parameters (Figure 2-2).

Chromium hydroxide solid solutions may precipitate as coprecipitates with other metals, rather than pure  $\text{Cr}(\text{OH})_3^0$ . This is especially true if oxidized iron [Fe(III)] is present in the aquifer; it will generate an amorphous hydroxide coprecipitate in the  $\text{Cr}_x\text{Fe}_{1-x}(\text{OH})_3$  form (Palmer and Wittbrodt, 1991). This chemical reaction is particularly important due to the potential for Fe(II) to be oxidized to the ferric state as previously discussed. Fe(II) is the most common oxidation state of dissolved iron in natural subsurface waters as well as aquifer minerals. Advantage is taken of this chemical reaction when employing permeable reactive barrier (PRB) *in situ* treatment of ground water. Zero-valent iron ( $\text{Fe}^0$ ) metal is used to reduce Cr(VI) to Cr(III) and complex the Cr(III) as a Fe(III) hydroxide coprecipitate.

Insoluble organic acid complex precipitates with Cr(III) and soil humic acid polymers are generally quite stable and present a barrier to

Cr(III) oxidation to Cr(VI). Cr(III) is tightly bound and immobilized by insoluble humic acid polymers.

The name given to this complexation process is chrome tanning because chromium has replaced aluminum in the tanning of leather. The chrome tanning of soil organic matter limits the tendency for Cr(III) to become oxidized and for the organic matter to be decomposed (Ross et al., 1981).

Adsorption reactions generally consist of cation exchange capacity (CEC) mechanisms for Cr(III) species and anion exchange capacity (AEC) mechanisms for Cr(VI) species. Adsorption generally involves cation exchange of Cr(III) as  $\text{Cr}^{+3}$  or hydroxy ionic species onto hydrated iron and manganese oxides located on the surface of clay soil particles. In CEC mechanisms, an aquifer mineral lattice or hydrated iron and manganese oxides located on the surfaces of fine-grained soil particles adsorb cations. Competition with other similar ions is possible and may limit the absorption of one particular species. Understanding CEC mechanisms is critical when considering *in situ* treatment technologies, such as soil flushing/chromium extraction and electrokinetic remediation. Generally, the lower the CEC of the soil, the better suited the soil for remediation by these technologies. Table 2-1 presents the CECs for various soil classifications (Dragun, 1988). The soil organic matter component of soil provides the greatest CEC, followed by the clay minerals vermiculite, saponite and montmorillonite. Clay offers the greatest CEC of all the soil types.

**Table 2-1. CECs for Soils – Components and Types.**

	CEC (meq/100g )
<b>Soil Clays</b>	
Chlorite	10-40
Illite	10-40
Kaolinite	3-15
Montmorillonite	80-150
Oxides and Oxyhydroxides	2-6
Saponite	80-120
Vermiculite	100-150
<b>Soil Type</b>	
Soil Organic Matter	> 200
Sand	2-7
Sandy Loam	2-18
Loam	8-22
Silt Loam	9-27
Clay Loam	4-32
Clay	5-60

In addition to soil cation exchange mechanisms for Cr(III) species adsorption, soil anion exchange is possible for adsorption of Cr(VI) anions [i.e., hydrochromate ( $\text{HCrO}_4^-$ ) and chromate ( $\text{CrO}_4^{2-}$ )]. These species exchange with chloride ( $\text{Cl}^-$ ), nitrate ( $\text{NO}_3^-$ ), sulfate ( $\text{SO}_4^{2-}$ ), and phosphate ( $\text{PO}_4^{3-}$ ). Griffin et al. (1977) studied the effect of pH on the adsorption of Cr(VI) by the clay minerals kaolinite and montmorillonite, and found adsorption was highly pH dependent; the adsorption of Cr(VI) decreased as pH increased, and the predominant Cr(VI) species adsorbed was  $\text{HCrO}_4^-$ . Bartlett and Kimble (1976b) also found that while chromate is tightly bound compared with anions such as  $\text{Cl}^-$  or  $\text{NO}_3^-$ , it can be released by reaction of the soil with  $\text{PO}_4^{3-}$ . The presence of orthophosphate prevented the adsorption of Cr(VI) anions, presumably by competition for the adsorption sites. They

concluded that the behavior of Cr(VI) remaining in soils is similar to that of orthophosphate, but unlike phosphate, Cr(VI) is quickly reduced by soil organic matter, thus becoming immobilized. Cr(VI), they state, will remain mobile only if its concentration exceeds both the adsorbing and the reducing capacities of the soil.

Sulfate adsorption on kaolinite also varied with pH, although not as strongly as for chromate. Zachara et al. (1988) suggested that, although  $\text{SO}_4^{2-}$  and  $\text{CrO}_4^{2-}$  compete for adsorption sites on noncrystalline iron oxyhydroxide,  $\text{SO}_4^{2-}$  and  $\text{CrO}_4^{2-}$  bind to different sites on kaolinite and, thus, do not compete for the same site. Studies by Zachara et al. (1989) of the adsorption of chromate on soils found the following:

- Chromate adsorption increased with decreasing pH.

- Soils that contained higher concentrations of aluminum and iron oxides showed greater adsorption of Cr(VI).
- Chromate binding was depressed in the presence of dissolved  $\text{SO}_4^{-2}$  and inorganic carbon, which compete for adsorption sites.

The importance of dissolved  $\text{SO}_4^{-2}$  as an inhibitor to chromate binding becomes apparent in Section 3. The technology described in Section 3.1.1, geochemical fixation, uses sodium metabisulfite as a reductant to reduce Cr(VI) in groundwater to Cr(III). Additional sulfur-based reductants are described in Section 3.1.3. Also, one of the Permeable Reactive Barrier (PRB) technologies described in Sections 3.2.1 and 3.2.3 uses sodium dithionite to reduce Fe(III) to Fe(II), which in turn reduces Cr(VI) to Cr(III). In all these processes,  $\text{SO}_4^{-2}$  is produced as a byproduct and can act as an inhibitor to Cr(VI) adsorption, thus allowing any residual Cr(VI) to remain in the mobile phase to be reduced to Cr(III).

*In situ* treatment methods for chromium-contaminated soil and groundwater generally involve the reduction of Cr(VI) to Cr(III) with subsequent fixation of Cr(III). Figure 2-4 presents examples of natural and chemical-induced reduction of Cr(VI) to Cr(III) and the mechanisms of subsequent fixation of Cr(III). The permanence of fixation must be evaluated since Cr(III) [as low molecular weight organic acid complexes (i.e., chromium citrate)] can migrate to the surface and reoxidize to Cr(VI) in the presence of manganese dioxide.

Manganese dioxide ( $\text{MnO}_2$ ) forms naturally in

the upper vadose zone by reduced manganese oxide (MnO) reacting with atmospheric oxygen. Bartlett (1991) states “the marvel of the chromium cycle in soil is that oxidation and reduction can take place at the same time.” This is an important principle for the application of *in situ* technologies for the treatment (reduction) of Cr(VI) and permanent fixation of Cr(III).

Figure 2-3 illustrates the apparent paradox of simultaneous oxidation and reduction of chromium. As shown, Mn(IV) (as  $\text{MnO}_2$ ) oxidizes Cr(III) to Cr(VI). However, under normal dry soil conditions, mobile Cr(III) [i.e.,  $\text{Cr}^{+3}$  or chromium citrate] will not oxidize to Cr(VI) in the presence of  $\text{MnO}_2$ . Mobile Cr(III) will not oxidize to Cr(VI) in the presence of  $\text{MnO}_2$  unless the soil is moist and the  $\text{MnO}_2$  surface present in the soil is fresh (i.e., amorphous rather than crystalline form) (Bartlett, 1991). Additionally, Mn(III)-organic acid complexes reduce Cr(VI) to its trivalent form. Mn(III) is formed when Mn(II) reacts with Mn(IV) in the presence of organic acids formed from soil organic matter (Bartlett, 1991). The cycle repeats itself as the Cr(III) formed may be chelated by low molecular weight organic acid complexes (e.g., citric acid) and thus, be mobile enough to migrate to the soil surface and consequently oxidize to Cr(VI).

Bartlett (1991) states that as long as all Cr(VI) has been reduced and all Cr(III) is bound by decay-resistant organic polymers, the chromium will remain inert and immobile, provided that oxygen is excluded. In other words, sealing of a landfill on the bottom to prevent leaching of chromium is unnecessary as long as the top is sealed.

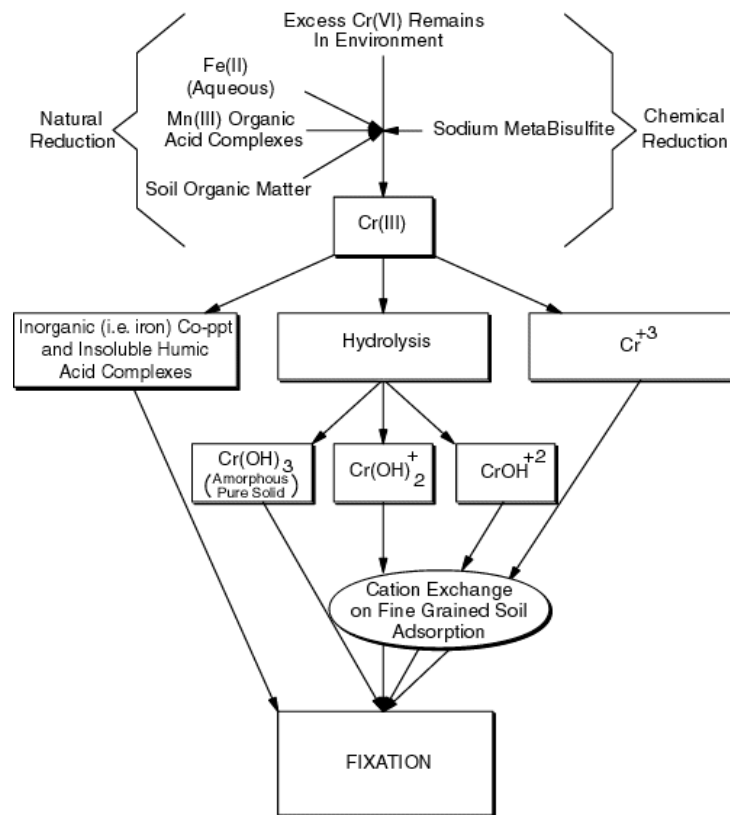

Figure 2-4 Chromium reduction and fixation.

### 2.3 Chromium Treatment and Remediation Approaches

Palmer and Wittbrodt (1991) discussed several remediation techniques for chromium-contaminated sites. Applicable to many sites is a pump-and-treat method. The technology works by extracting contaminated groundwater, usually over long time periods, and providing hydraulic control (containment) of a contaminant plume. Initially, the concentration of the contaminant is high in the effluent, but with continued pumping, the concentration decreases significantly. These residual concentrations remain above the MCLs, and can persist for long periods of time, called “tailing.” This same phenomenon was observed by Stollenwerk and Grove (1985) in their laboratory and batch column experiments. Figure 2-5 shows tailing and rebound effects

during and after groundwater pumping. Tailing is the result of several physical and chemical processes:

*Differential time for contaminants to be advected from the boundary of the plume to an extraction well:* Groundwater flows, not only in response to an extraction well, but also to the natural hydraulic gradient. As a result, not all of the water in the vicinity of an extraction well enters the well. There is a limited area, the capture zone, from which the water is captured, and a stagnation point, located downgradient from the well, where the velocity toward the well equals the velocity induced by the natural gradient. The net velocity is zero, and there is little change in the concentration of the contaminant during the pump-and-treat remediation. In addition, the groundwater velocity of a volume of water moving from the



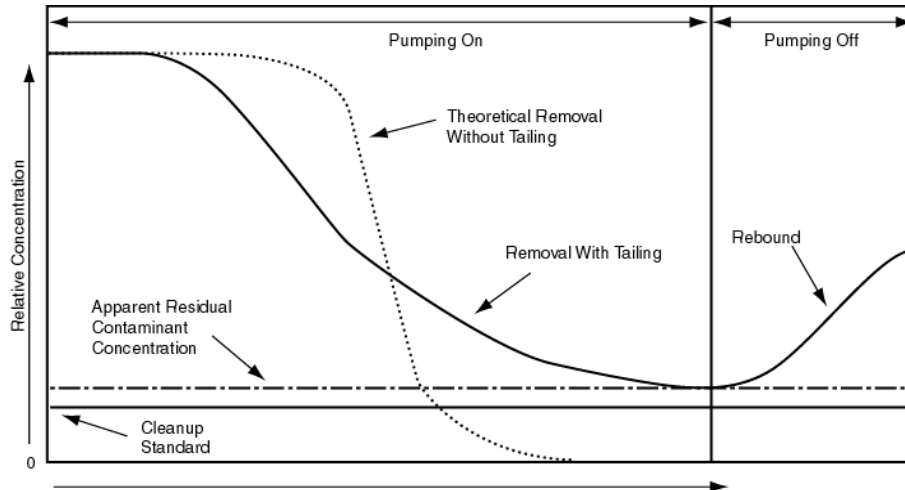

**Figure 2-5 Concentration versus pumping duration or volume showing tailing and rebound effects (Cohen et al., 1994).**

edge of the plume to the extraction well is greater than a volume of water traveling along a streamline on the outside of the capture zone. The time it takes the contaminated water to flow is controlled by the thickness of the aquifer, the rate of groundwater extraction, the natural groundwater gradient, and the gradient induced or impacted by other injection/extraction wells.

*Diffusive mass transport within spatially variable sediments:* Geologic materials are typically heterogeneous; groundwater moves through higher permeable layers while water in lower permeable layers remains immobile. Contaminants that have remained in the subsurface for extended periods of time migrate to the lower permeable layers by molecular diffusion. During pump-and-treat, clean water is moved through the more permeable layers at a relatively high rate, while removal of the contaminants from the lower permeable lenses is limited by the rate of diffusion into the higher permeable layers; thus maintaining the concentration of the contaminant, often above the established MCL.

*Mass transfer from residual solid phases in the aquifer:* Contaminants can exist in the subsurface in relatively large reserves as solid phase precipitates. A likely reserve for chromium contaminated sites is barium chromate ( $\text{BaCrO}_4$ ), the source of the barium either coming from contamination or from the natural soil.

Palmer and Wittbrodt (1991) conducted a study at a United Chrome Products site and suggested that the Cr(VI)-contaminated groundwater was in equilibrium with  $\text{BaCrO}_4$ . Column leaching tests of the contaminated soils showed a significant leveling of the Cr(VI) concentrations, indicating that a solid phase may be controlling the concentration in the extraction water.

*Sorption/desorption processes:* As discussed previously, Cr(VI) exists in solution as the anions  $\text{HCrO}_4^-$ ,  $\text{CrO}_4^{2-}$ , and dichromate ( $\text{Cr}_2\text{O}_7^{2-}$ ), and is adsorbed onto the soil matrix. As the concentration of Cr(VI) decreases, it becomes more difficult to remove the Cr(VI).

The use of *in situ* technologies such as chemical enhancement of the pump-and-treat method (the addition of reductant or extracting agent) may be desirable to overcome the tailing phenomenon and reduce the overall time required for remediation. However, the cause of tailing at a given site needs to be determined and quantified. For example, if the tailing is controlled by physical processes such as differential travel time along streamlines, or heterogeneity of the soil, then chemical enhancement may not be advantageous. Further, regulatory agencies may require the removal of the chemical enhancer. This is especially true if the chemical enhancer or its

byproducts exceed the concentration(s) of applicable water quality standards.

Typically, chromium-contaminated sites consist of three zones: (1) source zone soils where the concentrated waste resides; (2) the concentrated portion of the groundwater plume; and (3) the diluted portion of the groundwater plume (Sabatini et al., 1997). Figure 2-6 illustrates these three zones of contamination. Applying conventional pump-and-treat remediation methods to all three regions would be highly inefficient. An integrated technology approach would probably be best suited for full-scale site remediation.

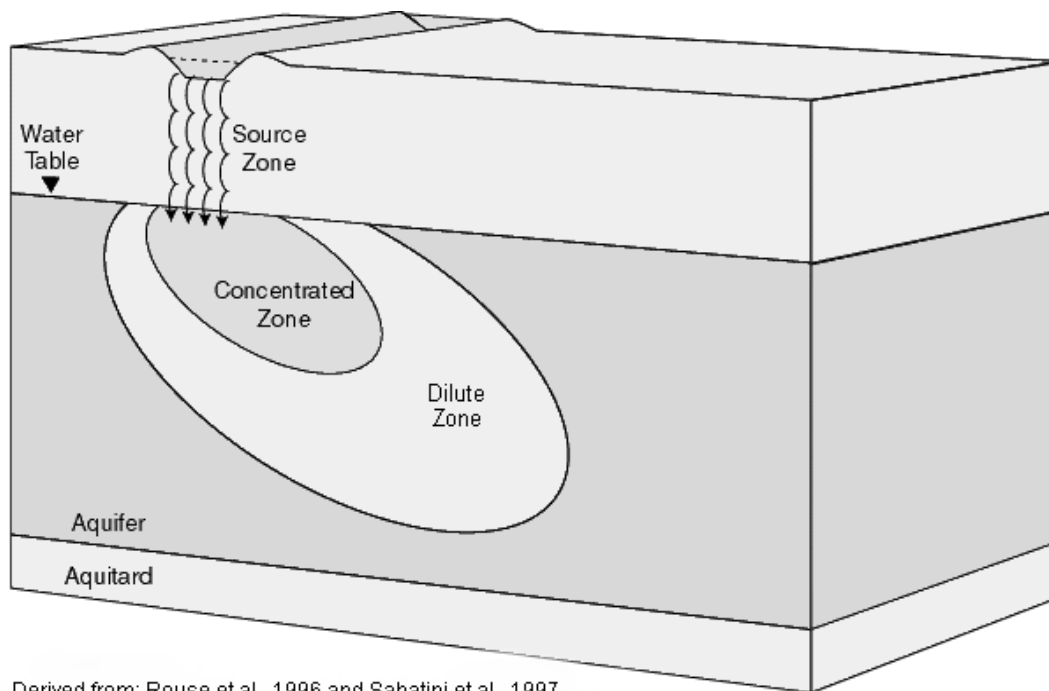

Derived from: Rouse et al., 1996 and Sabatini et al., 1997.

**Figure 2-6 Conceptual geochemical model of zones in a contaminant plume.**

## **Available Technologies**

A number of *in situ* technologies or approaches use chemical reduction/fixation for chromium remediation. These include geochemical fixation, PRBs, reactive zones, and natural attenuation. Understanding the Chromium Cycle presented in Section 2.2 and site characteristics presented in Section 2.4 is critical for the use of these approaches, especially natural attenuation. Chemical reduction/fixation remediation techniques do not remove chromium from the aquifer system, but are designed to immobilize chromium precipitates by fixing them onto aquifer solids or reactive media, thereby reducing chromium in groundwater. Other types of *in situ* treatment that are available or under development for remediation of chromium-contaminated sites include soil flushing/enhanced extraction, electrokinetics, and biological processes including phytoremediation. Biological processes include bioreduction, bioaccumulation, biomineralization, and bioprecipitation which use specific substrates to drive the treatment and effect the reduction, uptake, or precipitation of Cr(VI) based on the principles presented in Section 2.2. These processes can be utilized within PRBs and reactive zones. Phytoremediation utilizes plant uptake of chromium contamination as the *in situ* treatment approach.

A detailed discussion of these *in situ* technologies is presented in Section 3 of this Guide. More conventional *ex situ* approaches are not reviewed in this Guide.

## **2.4 Site Characterization Requirements**

The remediation site should be characterized to determine how suitable it is for Cr(III) fixation or for other treatment applications. Chemical characterization should include the following:

*Site Characterization:* Site characterization should include a determination of total organic carbon (TOC) and dissolved organic carbon

(DOC) in groundwater and soil. Both tests will indicate not only the availability of soluble organic ligands for Cr(III) complexing, which provides a mobilization vehicle for potential oxidation to Cr(VI), but also the availability of more complex organic matter which has the potential for reduction of Cr(VI) to Cr(III). The particulate (or solid fraction) of organic carbon in the aquifer can be determined by subtracting DOC from TOC. A total Cr(VI) reducing capacity of the soil should be determined to measure the portion of organic matter in the soil that is oxidizable by Cr(VI). The Cr(VI) not reduced is titrated with Fe(II). CEC should be measured to determine if sites are available for the Cr(III)-hydroxy cation complexes to adsorb onto the soil particles. Other tests that can be performed as needed are porosity, grain size, soil moisture, and total manganese.

*Groundwater:* Both contaminated and treated groundwater should be analyzed for total chromium and Cr(VI); Cr(III) is determined by subtracting the results of the Cr(VI) from the total chromium values. Eh and pH should also be determined.

*Soil :* Like the groundwater, both contaminated and treated aquifer solids and unsaturated soil should be analyzed for total and Cr(VI). Additional tests should be conducted for pH and the amount of dissolved Cr(III) that is mobile (not fixed). Further, in order to determine if, and how much of, the Cr(VI) was reduced, a mass balance should be performed. Other soil tests that can be performed as needed are the standard chromium oxidation test; Cr(III) oxidizable by excess MnO<sub>2</sub>; and oxidizability of inert Cr(III). The methods for these tests, along with their rationale, are presented in Bartlett (1991).

Table 2-2 lists recommended analytical methods. The tests presented in Table 2-2 are meant to be a guide as to the types of analytical parameter measurements that are helpful in understanding the ongoing geochemical processes at a site as they relate chromium remediation. The list of analytical parameters is not meant to be comprehensive, but should provide a good foundation.

**Table 2-2. Recommended Analytical Methods**

Sample Type	Analyte	
<b>Site Characterization</b>	TOC (water)	EPA 415.1 or 415.2
	TOC (soil)	SW-846 modified 9060
	DOC (water)	0.45 µm filter, then EPA 415.1 or 415.2
	Particulate Organic Carbon	TOC minus DOC
	Soil pH	SW-846 9045C (use distilled water)
	Groundwater pH	EPA 150.1
	CEC	EPA 9081
	Total Cr(VI) reducing capacity by soil	Walkley-Black method
	Total manganese (soil)	Digest: SW-846 3050B, 3051, or 3052 Analysis: SW-846 7460, 6010B, or 6020
<b>Groundwater Pre- and Post-Treatment</b>	Total Chromium	0.45 µm filter, Digest: SW-846 3020A Analysis: SW-846 7191 -or- Digest: SW-846 3005A Analysis: SW-846 6010B or 6020
	Cr(VI)	0.45 µm filter Analysis: SW-846 7196A
	Cr(III)	Total Cr – Cr(VI)
<b>Soil Pre- and Post-Treatment</b>	Total Chromium	Digest: SW-846 3050B, 3051, or 3052 Analysis: SW-846 7090, 6010B, or 6020
	Cr(VI)	Digest: SW-846 3060A Analysis: SW-846 7196A
	Trivalent Chromium	Total Cr – Cr(VI)
	Available Cr(III) (to be mobilized)	Prep: K <sub>2</sub> H - citrate extract (Bartlett, 1991) Analysis: SW-846 7196A
<b>Soil Post-Treatment (Leachate)</b>	Cr(III)	Leachate: Title 22 Waste Extraction Test (WET) Digest: SW-846, 3010A Analysis: SW-846 7090, 6010B, or 6020 -or- Digest: SW-846 3020A Analysis: SW-846 7191

There may be other measurements that could be added to this list to obtain a better understanding of the geochemical processes at any one site. Whenever possible, EPA SW-846 analytical methods were proposed because their performance effectiveness has been validated, the methods are commonly used in the literature and provide a high degree of data comparability, and they have been approved by EPA. For some analytical parameters there is more than one proposed analytical method. This provides greater flexibility to the users of this Guide. For example, there are two choices for digestion techniques and three choices for analysis for total chromium in groundwater.

Although all the digestion and analytical techniques are valid, one may choose to analyze for chromium at a site at which low levels are expected by SW-846, 7191 (atomic

adsorption, furnace) rather than 6010B or 6020 inductively coupled plasma/atomic emission spectrometry or mass spectrometry (ICP/AES or ICP/MS), because the detection limit is lower by 7191. The digestion method to use for analytical method 7191 is SW-846 3020A, and digestion method SW-846 3005A is to be used with analytical methods 6010B and 6020. In addition to site chemistry, it is also critically important for *in situ* technology implementation to understand the contaminant distribution and geologic setting. This includes geologic structure, stratigraphy, and ground-water hydrogeology. Complicated geology and low permeability zones will influence how a technology is applied and its treatment effectiveness. Laboratory and pilot-scale tests can help to determine the effectiveness of the treatment on the contaminated matrix prior to full-scale application of the technology.

## Section 3

### TECHNOLOGIES FOR *IN SITU* TREATMENT

This section discusses innovative technologies that can potentially be used for *in situ* remediation of chromium-contaminated soil and groundwater. More conventional technologies for treatment or control of chromium and metals contamination such as pump-and-treat, containment, solidification/stabilization, and even thermal treatments, are not reviewed here because they are either *ex situ* approaches or are proven and well-documented elsewhere. The emphasis in this Guide is on innovative *in situ* approaches that are not as well documented in order to provide the reader with the latest information for decision-making purposes.

For clarification, individual technologies and two technology groups are presented in this section. The individual technologies are geochemical fixation, soil flushing/chromium extraction, electrokinetics, natural attenuation, and phytoremediation. The technology groups are subsurface PRBs and reactive zones. Numerous biotic and abiotic applications can be utilized within these technology groups and are discussed. The emphasis in this Guide is on the technologies or treatment approaches *proven or demonstrated for in situ* chromium remediation - geochemical fixation and PRBs.

These technologies have been utilized at full-scale and are generally supported by performance and cost data.

Reactive zones, soil flushing, and electrokinetics are *developing* technologies that have been demonstrated at pilot-scale and have limited performance and cost data available. Natural attenuation and phytoremediation are *emerging* technologies under study for *in situ* chromium remediation. All are covered briefly in this Guide. Each technology or technology group is presented in a separate section that provides a technology description, advantages and limitations of using the technology, its status, and performance and cost information, if available.

No technology may be able to remove 100 percent of the contaminants that are present at a site. Consequently, it is important to determine the benefits of partial mass removal and relate this to risk reduction. Many sites will require different approaches to different parts of the site. As a result, there is a need to better understand how to link technologies together to achieve site cleanup in the most cost-effective manner (Schmelling, 1999).

Table 3-1 summarizes the status of the technologies discussed in this section.

**Table 3-1. Status of *In Situ* Technologies for Treatment of Chromium Contamination**

	TREATMENT ZONE <sup>1</sup>	CONTAMINATED MEDIA	STATUS <sup>2</sup>	TREATMENT COST ESTIMATE <sup>3</sup>	REGULATORY ACCEPTANCE
<b><i>Proven Technologies</i></b>					
GEOCHEMICAL FIXATION	S, C, D	Groundwater Soil	DE, FSA, FTS DE, FTS	\$4/m <sup>3</sup> (\$3/yd <sup>3</sup> ) for saturated zone using ferrous sulfate <sup>4</sup>	Gaining acceptance: depends on site evaluation results and reductants proposed for use.
PRBs					
• Chemical Reduction & Fixation (Reactive Media)	C, D	Groundwater	DE, FSA, FTS	- O&M 70-90% less than P&T per year.	Physical treatment walls are starting to gain regulatory acceptance. R&D supported by EPA and other organizations.
• Chemical Reduction & Fixation (ISRM)	C, D	Groundwater	PE, FTS	- \$3 mil./10 yr vs. \$9 mil. for P&T.	
• Adsorption & Chemical Reduction (Zeolite/ZVI)	C, D	Groundwater	PE, BTS	- NA	
<b><i>Developing Technologies</i></b>					
REACTIVE ZONES					
• Chemical Reduction & Fixation (Reactive agent)	S, C, D	Groundwater	DE, FSA, FTS	NA	May be difficult to get regulatory approval without further research and demonstration of these treatment techniques.
• Bioreduction (Molasses)	S, C, D	Groundwater	DE, FSA, FTS	\$400,000/3 yr vs. \$4 mil/20 yr for P&T.	
• Bioaccumulation (Yeast)	C	Groundwater	PE, BTS	NA	
• Bioprecipitation (DMRB)	S, C	Groundwater	PE, BTS	NA	
• Biomineralization	S, C	Groundwater, Soil	PE, FTS	NA	
SOIL FLUSHING/ EXTRACTION	S, C, D	Groundwater Soil	DE, FSA; PE, BTS DE, FSA	\$60 to \$170/ton, or \$83 to \$237/m <sup>3</sup> at assumed soil density of 100 lb/ft <sup>3</sup> <sup>5</sup>	Some acceptance for water-only flushing applications. More difficult for surfactants or other additives. Hydraulic control is an issue.
ELECTROKINETICS	S, C	Groundwater Soil	DE, FTS, BTS PE, FTS	\$25 to \$300/m <sup>3</sup> , or \$19 to \$229/yd <sup>3</sup> <sup>5</sup>	Case-by-case acceptance for a developing technology. Needs more research and demonstration.

Table 3-1. (continued)

	TREATMENT ZONE <sup>1</sup>	CONTAMINATED MEDIA	STATUS <sup>2</sup>	TREATMENT COST ESTIMATE <sup>3</sup>	REGULATORY ACCEPTANCE
<i>Emerging Technologies</i>					
NATURAL ATTENUATION	C, D	Groundwater Soil	PE, FTS PE	Detailed site characterization and performance monitoring costs	Beginning to gain regulatory acceptance in general. Uncertain for Cr remediation - highly dependent on site characteristics.
PHYTOREMEDIATION	C, D	Groundwater Soil	PE, FTS PE, FTS	\$10 to \$60/ton, or \$18 to \$104/m <sup>3</sup> at assumed soil density of 100 lb/ft <sup>3</sup> <sup>5</sup>	May be difficult to get regulatory approval without further research. Early stage of development for metals remediation.

<sup>1</sup> S=Source zone soil or groundwater, C=Concentrated groundwater plume, D=Diluted groundwater plume

<sup>2</sup> DE=Demonstrated Effectiveness, PE=Potential Effectiveness, FSA=Full-scale Application, FTS=Field-scale Treatability Study, BTS=Bench-scale Treatability Study

<sup>3</sup>These costs were compiled from studies presented in this document and are for informational purposes only; actual treatment costs are highly site and application specific and may vary considerably from costs presented here. Costs in this document have not been adjusted to year 2000 dollars and may not include profit.

<sup>4</sup>Does not include treatability and design costs, which were significant.

<sup>5</sup>These cost estimates may not include indirect costs such as permits, treatment of residues, and site preparation.

NA=Not Available



## 3.1 Geochemical Fixation

### 3.1.1 Technology Description

The goal of this technology is to reduce Cr(VI) in groundwater and contaminated soil to the more thermodynamically stable Cr(III). The reduced chromium is expected to geochemically fix onto aquifer solids. The technology is based upon the concept of extracting contaminated groundwater and treating it above ground, followed by reinjection of the treated groundwater into the aquifer. The reinjected groundwater is dosed with reductant to reduce any residual Cr(VI) contamination remaining in the interstitial water. This technique, if successful, yields Cr(VI) concentrations in groundwater below that of drinking water standards (50 µg/L) at a fraction of the aquifer pore volume throughput required by typical pump-and-treat methods.

The success of the *in situ* chromium geochemical fixation technology depends on the ability of the applied reductant to reduce Cr(VI) in groundwater to Cr(III), and on the capacity of the reduced chromium to fix onto the aquifer solids. The total chromium concentration in the aquifer system is not decreased, but chromium is precipitated and fixed (immobilized) onto aquifer solids as Cr(III) so that it is not available in the groundwater. Some information is available indicating how sodium metabisulfite might act as a reductant in the subsurface. In general, sulfur compounds such as sulfide and sulfite reduce Cr(VI). For sulfides to reduce Cr(VI), Fe(II) must be present to act as a catalyst. Thus, in aquifer systems where iron sulfides are present, reduction of Cr(VI) may occur. However, because the rate of reaction is slow, the iron sulfide reduction process may not effectively treat large volumes of water.

According to Palmer and Wittbrodt (1991), the following reactions occur. In the presence of excess sulfite, the reduction of Cr(VI) follows the reaction:

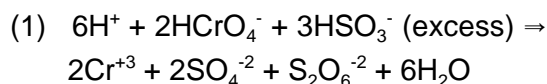

The metabisulfite ( $\text{S}_2\text{O}_6^{-2}$ ) formed by the above reaction can then reduce oxidized Fe(III) to Fe(II), if it is present. This situation allows for potential reduction of Cr(VI) by Fe(II), as previously described. In the presence of excess Cr(VI), the reduction to Cr(III) by sulfite follows the reaction:

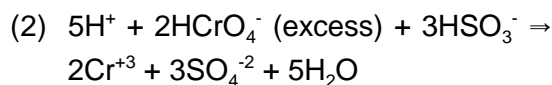

Therefore, the process of using sodium metabisulfite should reduce the Cr(VI) to Cr(III) *in situ*, provided there are sufficient iron and manganese oxide adsorption sites within the aquifer treatment zone to which the Cr(III) can affix.

Using the technology, groundwater is extracted, treated with a chemical reagent, and reinjected along the contaminant plume perimeter (see Figure 3-1). As the treated water is directed towards the center of the plume, Cr(VI) is reduced to Cr(III), its less soluble form. The zone of contamination is driven inward by the reaction front, leaving behind an increasingly larger clean water zone. Alternatively, injection can occur in the high concentration areas (source zones) to effect a more rapid remediation (Brown et al., 1998). *In situ* geochemical fixation can be applied to source or core zones, the concentrated or active zone, or the dilute or neutralized zone of the contaminant plume.

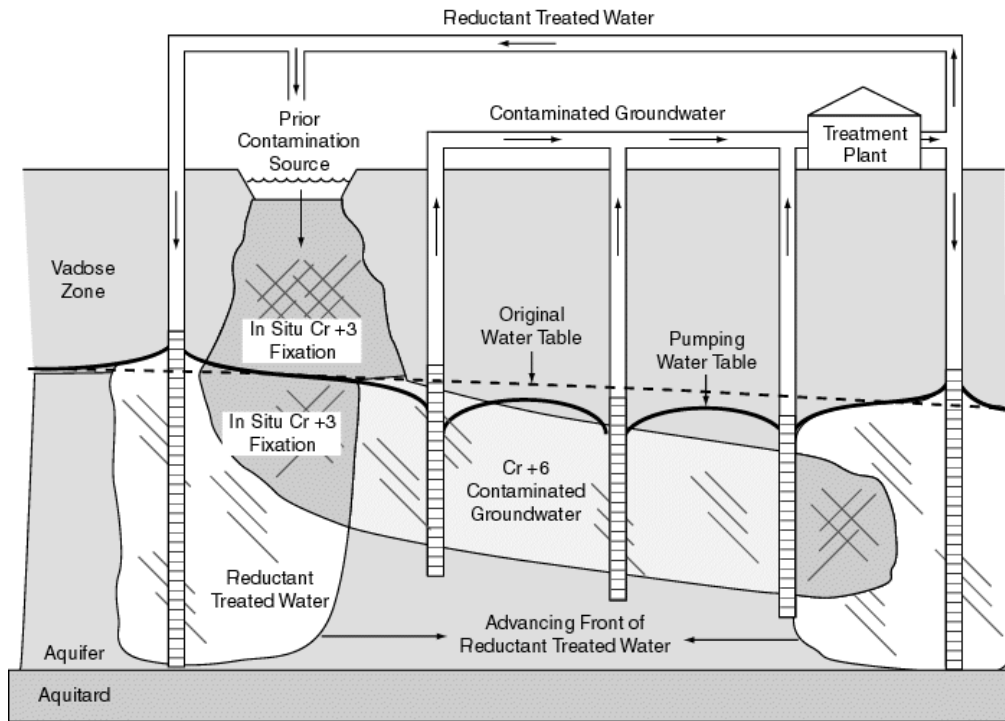

Source: Rouse, 1997

**Figure 3-1 Schematic of *in situ* chromium remediation.**

The technology has also been used for *in situ* reduction and fixation of Cr(VI) retained as dissolved chromium in interstitial water in the vadose (unsaturated) zone. In such applications, groundwater is recovered from near the area of contaminated soil, amended with the selected reductant, and percolated through the soil. The percolation displaces a portion of the moisture from the vadose zone (hence the need to recover the groundwater from near the area of contamination), but also reduces and fixes the residual chromium onto the soil as Cr(III). This technique has been applied in geologic material as diverse as silt, glacial outwash sand, fractured siltstone, and limestone with extensive solution features. The effectiveness of the approach is best measured by the use of pressure/vacuum lysimeters to

sample the interstitial fluids (Rouse, 1999). Geochemical properties that should be evaluated for use of the technology include acid and base neutralizing potential, iron and manganese hydrous-oxide content, TOC, and CEC (Rouse and Pyrih, 1990). Analysis of the anions sulfate, phosphate, chloride, and nitrate and AEC may also be valuable for the evaluation of their competition with Cr(VI) for sorption sites on aquifer solids, and how well Cr(VI) can be mobilized for treatment (reduction). The site hydrogeology must also be well understood; successful application requires a good knowledge of the hydrogeology and expertise at designing and physically implementing the process. Section 2 of this Guide provides more detail about process geochemistry and site characterization needs.

Extraction and injection wells are required to remove contaminated groundwater for aboveground treatment and to reinject the treated and amended water into the treatment zone. Extraction wells from an existing pump-and-treat system can often be utilized. The aboveground system consists of the selected treatment apparatus for initial chromium removal, tanks for storing treatment chemicals and extracted and treated groundwater, and a reductant dosing system for the treated water. A sheltered area or building is needed to perform the on-site chemical tests, handle and prepare the chemical reductant, and to store spare parts such as backup pumps and valves.

A significant advantage to using *in situ* geochemical fixation is that it has the potential to substantially reduce (up to 75 percent) the time required to remediate chromium-contaminated sites to meet cleanup goals, and thus reduce treatment (operating) costs. Other advantages are listed below.

### Advantages

- Better hydraulic control is achieved by the reinjection of treated water around the contaminated plume, forming a “ridge” of treated water.
- Since water is reinjected, the same gradient can be established at lower pumping rates, thereby avoiding “stranding” of chromium in dewatered portions of the previously saturated aquifer.
- *In situ* reduction of residual Cr(VI) in interstitial void spaces can be achieved.
- The amount of treatment plant sludge for disposal is reduced since more Cr(VI) is reduced and precipitated *in situ*.
- The surface discharge of treated water is reduced since water is reinjected (Rouse, 1994; Rouse and Pyrih, 1990; Rouse, Leahy and Brown, 1996).

### Limitations

- Aquifer materials must have the ability to permanently “fix” Cr(III).
- Reduced Cr(III) could re-oxidize to Cr(VI) under certain conditions (presence of manganese dioxide [MnO<sub>2</sub>]); however, this has not been observed in the field.
- Need regulatory approval for reinjection of pumped and treated groundwater.
- Aquifer material heterogeneities (stratification, etc.) makes design and treatment more difficult.
- Aquifer solids must be porous to water flow.
- Ferrous sulfate-based reductants may result in iron precipitation and clogging of aquifer pore spaces.
- Excess reductant or reductant byproduct may have to be removed if undesirable or if it exceeds groundwater MCLs.

### 3.1.2 Status

This technology has undergone testing and is currently being employed at contaminated sites using calcium/sodium polysulfide and sodium metabisulfite chemical reductants to effect the conversion of Cr(VI) to Cr(III) (Rouse, 1997). *In situ* remedial systems are or have been in operation at chromium contaminated sites in California, Indiana, Maryland, Maine and South Australia, and are planned for Michigan and additional sites in California.

The technology is also being tested and applied on soil and groundwater at a Superfund site in South Carolina using infiltration and well injection methods (Howard, 1998). Ferrous sulfate is the reductant of choice for this application. The technology will become part of the final remedial design for the site.

*In situ* geochemical fixation can also be applied to a site remediation using more passive techniques such as *in situ* PRBs, or reactive zones. These approaches are presented in Sections 3.2 and 3.3 of this Guide.

### 3.1.3 Performance and Cost Data

#### Delaware River

At the site of a former paper mill on the Delaware River, the Cr(VI) concentration in the perched aquifer was 85 mg/L (85,000  $\mu$ g/L). After treatment by reduction and precipitation using ferrous sulfate, Cr(VI) levels across most of the site were reduced to 50  $\mu$ g/L (below the drinking water standard). These levels have been maintained for over 4 years (Brown et al., 1998). This was the first commercial application of the iron reduction process for treating Cr(VI) in soils and groundwater. The total cost of the project was \$250,000, which is approximately

would have been required to initiate pump-and-equal to the cost of capital equipment that treat. For perched groundwater treatment, the application of an acidified ferrous sulfate heptahydrate was carried out using a combination of infiltration galleries, addition point/wells, and a vertical trellis network. No groundwater was extracted for treatment and reinjection; therefore, no treatment sludge was generated that required disposal.

#### Indiana

A wood treatment plant site in Indiana had four areas of soil and groundwater contaminated with Cr(VI), a by-product of the CCA solution used to treat wood. Four plumes from the site threatened the domestic drinking wells. With conventional pump-and-treat technologies, cleaning up this site could have taken more than 10 years at a cost of several million dollars. However, the site plumes were remediated using geochemical fixation by extracting and mixing groundwater with a reductant and reinjecting the treated water through upgradient soils and groundwater. In the critical "off-site" plume, Cr(VI) was reduced to below the residual health-based groundwater criterion of 0.1mg/L in 2 months using a calcium polysulfide reductant. Smaller on-site plumes were treated by addition of sodium bisulfide reductant via injection wells. After 3 months of treatment, chromium levels in all three wells had gone from concentrations of up to 0.80 mg/L to less than 0.01 mg/L. Hot-spots were also being treated. It should be noted that in some locations, Cr(VI) levels were already at or near the groundwater criterion, so significant reductions were not required. Work on these projects began in 1995 and was completed in 1997 at a total cost of approximately \$600,000 (Rouse et al., 1999).

### Central California

As much as 6,000 pounds of Cr(VI) are estimated to have been released to the site soil and groundwater from wood treating operations at the Valley Wood Preserving site in Turlock, California. A groundwater pump-and-treat system maintained hydraulic control of the plume, treated nearly 9 million gallons of water, and recovered about half (3,000 pounds) of the Cr(VI). It was estimated that recovery of the remaining contamination would have required another 10 years of treatment (Brown et al., 1998). Bench-scale parallel column tests were conducted to evaluate the efficacy of the use of a reductant on chromium contamination. Three paired column tests were performed, each using actual chromium-contaminated aquifer material. For each paired column, one column was flushed with demineralized water to simulate the typical response of a pump-and-treat or “clean water sweep” remedial approach, and the other with a mild reductant solution designed to achieve *in situ* reduction and fixation of Cr(VI).

Table 3-2 presents the results from the column tests. The data demonstrate that the reductant-treated water achieved effluent concentrations less than the drinking water standard of 0.10 mg/L after 4 to 6 pore volumes (a pore volume is the volume of groundwater in the pore spaces of a defined aquifer zone), while columns flushed with only water exceeded the standard after 14 to 17 pore volumes (Rouse, 1994). Next, the efficacy and potential of *in situ* geochemical fixation as a treatment alternative was demonstrated by conducting an on-site pilot test. The on-site pilot test consisted of a “push-pull” test. This test involves removing a measured quantity of water from a contaminated well, treating it with the appropriate reductant (predetermined), returning it to the well, and after a period of time, collecting samples from the well to measure the effect of the added chemical reductant. Based on these results, a sulfur-based reductant (sodium metabisulfite) is being used to remediate Cr(VI) at this site (Brown et al., 1998).

**Table 3-2. Total Chromium Concentrations (mg/L) of Paired-Column Effluent as a Function of Throughput**

Pore Volume	Soil A		Soil C		Soil D	
	Demineralized Water	Reductant Solution	Demineralized Water	Reductant Solution	Demineralized Water	Reductant Solution
1	270	210	2,800	2,800	1,700	1,700
2	65	17	220	120	120	34
3	38	6.8	18	1.05	23	0.62
6	19	0.05	10.5	0.01	4.1	0.02
9	15	-	-	-	-	-
10	-	0.06	1.35	0.02	0.49	<0.01
14	-	-	-	-	0.19	-
17	-	-	0.22	-	-	-

- = No sample taken.

A full-scale treatment system has been in operation since January 1998 and has reduced the maximum chromium concentrations by more than an order of magnitude. *In situ* treatment from February 1998 through October 1999 has resulted in a reduction in plume size and mass of dissolved chromium in groundwater of about 98 percent, according to investigators. This reduction can be seen by Cr(VI) iso-concentration plots with time in Figures 3-2 and 3-3. This significant reduction in Cr(VI) in groundwater was accomplished in approximately 2 years after 7 years of conventional groundwater extraction and treatment (Thomasser and Rouse, 1999; Thomasser, 1999). Monitoring data in the June 2000 status report indicate that all but a few groundwater monitoring wells met the 0.05 mg/L cleanup standard for Cr(VI). Levels of Cr(VI) in 5 of the 31 monitoring wells were slightly above the standard.

*In situ* remediation with chemical reductant was terminated at this site in October 1999 and a closure monitoring program was implemented under EPA oversight. Groundwater extraction, treatment, and reinjection without reductant has continued (Thomasser, 2000a). The plan is to shut off select recovery wells as they reach cleanup levels for chromium (and arsenic) and to formally close the site. However, recent groundwater monitoring data also indicate that sulfate concentrations in many monitoring wells have increased to greater than the national secondary drinking water standard of 250 mg/L as a result of the Cr(VI) remediation effort. In addition, manganese concentrations have increased to greater than the standard of 0.05 mg/L in a few locations (Lau, 2000). Project cost data were not available during preparation of this Guide.

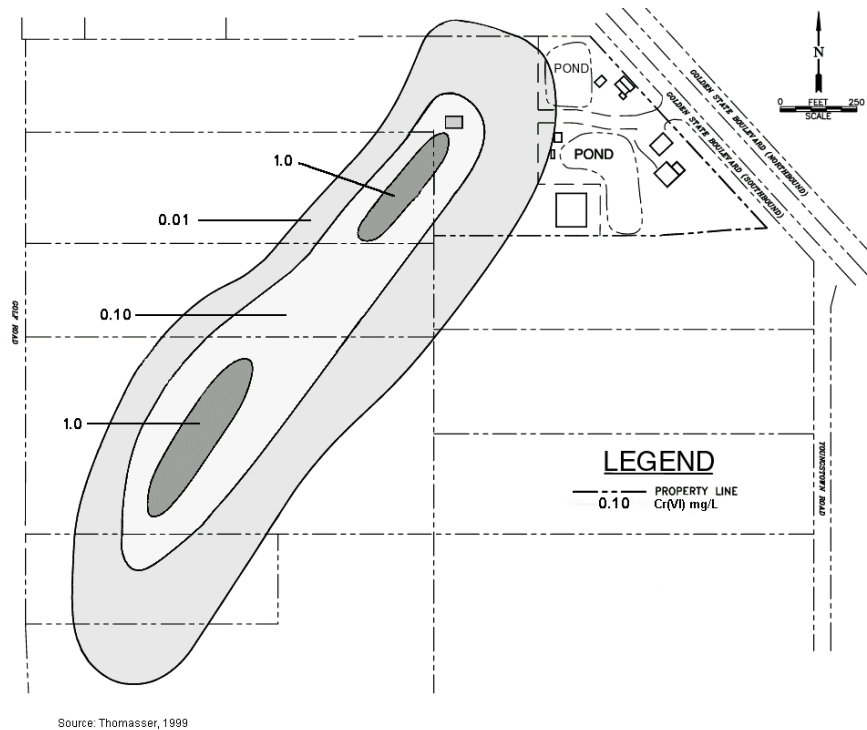

**Figure 3-2. Plot of Cr(VI) contaminant plume at the Valley Wood Preserving site - January 1998.**

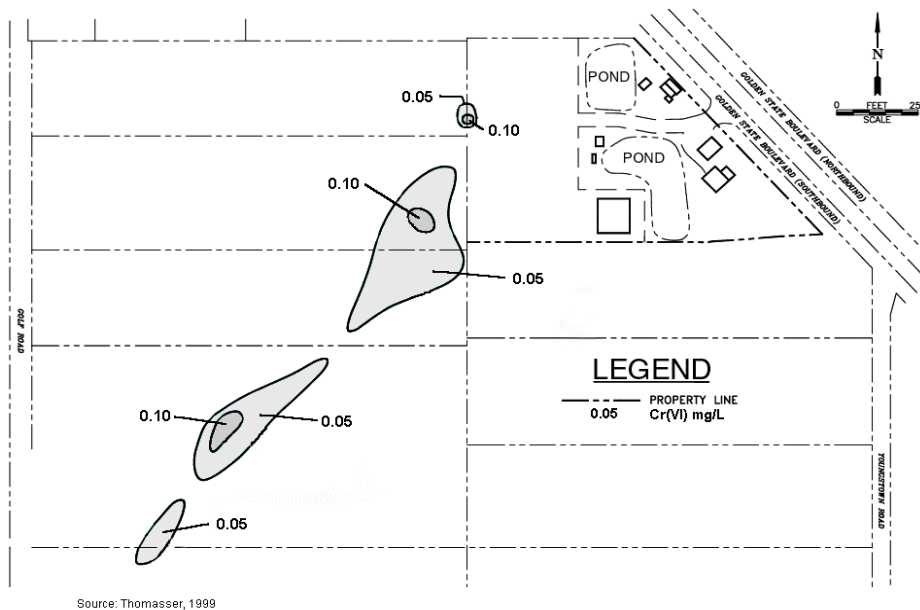

**Figure 3-3. Plot of Cr(VI) contaminant plume at the Valley Wood Preserving site - November 1999.**

### **Northern California**

At two former wood treating sites in northern California, pump-and-treat techniques were used to control off-site Cr(VI) migration prior to initiation of *in situ* efforts. However, low permeability reduced the ability to recover groundwater. Field tests of ferrous ion injection further reduced the permeability due to iron precipitation and clogging of soil pore spaces. A sulfur-based reductant was then used in a field-scale program. Because the ability to use groundwater extraction and reinjection was hampered at these sites, the reductant was introduced by direct-push pressure injection and hydrofracturing across the plume. This was enhanced by a program of reductant infiltration in the vadose zone of the source area. Groundwater monitoring at both sites has shown a declining trend in Cr(VI) concentrations. Treatment is ongoing. Areas of localized elevated levels of Cr(VI) may still exist. Additional direct-push injection was planned for these areas prior to site closure (Thomasser and Rouse, 1999; Thomasser, 2000b).

### **South Australia**

This site is the location of a CCA wood-treating facility in South Australia. The site is underlain by cavernous limestone and is approximately 1 km upgradient of the water supply of a city of approximately 25,000 people. Investigators are currently involved in the *in situ* fixation of chromium in both the saturated and vadose zone.

Groundwater remediation is performed by pumping from a series of recovery wells within the core of the plume, treating the water by the addition of a sulfur-based reductant, and injecting the water into a series of wells around the plume. During the first year of operation, the mass of dissolved Cr(VI) in the plume was reduced by 55 percent, despite the continued input of chromium to the groundwater from seepage through the vadose zone (Thomasser and Rouse, 1999). Of this reduction, a calculated 85 percent occurred *in situ*, and only 15 percent resulted from the surface treatment. Reductions in Cr(VI) concentrations in groundwater were most significant in areas

around the margins of the contaminated plume. The effect of groundwater treatment in the interior of the plume has not been as significant; Cr(VI) concentrations in monitoring wells have been inconsistent. However, ongoing *in situ* remediation is anticipated to show reduction of Cr(VI) concentrations from plume margins towards the interior, progressively until the remediation target of 0.05 mg/L is achieved (Rouse, 1999a)

For treatment of the vadose zone, a series of infiltration pits was constructed in the area of the former wood treating cylinder sump and the drip pad. Excess stormwater is amended with sulfur-based reductant and discharged to the pits. The water percolates through the solution features, which previously served as pathways for the contamination. The effectiveness of the percolation is measured by a network of pressure/vacuum lysimeters in the vadose zone and monitoring wells in the saturated zone. One lysimeter located in the treatment cylinder sump yielded a sample containing 58 mg/L before the initiation of percolation. Within 2 weeks the chromium concentration in the lysimeter sample dropped to less than 0.01 mg/L. Samples from a well near the pit increased from a prior concentration of 3.8 mg/L chromium to a peak value of 120 mg/L and then dropped to less than 0.01 mg/L chromium within 10 weeks of the initiation of percolation (Thomasser and Rouse, 1999).

### **South Carolina**

The use of *in situ* geochemical fixation is also being evaluated at the Townsend Saw Chain site in Pontiac, South Carolina. Investigators have been conducting on-site treatability testing in order to complete the remedial design for application of the technology. Discharged waste water from spent chromium plating solutions has leached Cr(VI) into the shallow groundwater aquifer. Soils in localized areas of the former waste ponds have Cr(VI) concentrations ranging from a few mg/kg to as high as 30,000 mg/kg. Groundwater impacts

downgradient from the former ponds reach levels approaching approximately 4 mg/L Cr(VI). Treatability testing has been conducted on soil and groundwater. The objective of soil testing was to determine whether surface application of ferrous sulfate solution would effectively reduce Cr(VI) and immobilize chromium in vadose zone soil. The surface application of reductant solution was accomplished using an existing spray field piping network and soaker hoses. The average Cr(VI) reduction percentages were 84 percent for saturated soils, and 61 percent for drier, unsaturated soils. Reductions as high as 97 percent were measured. Although significant reductions were observed, only one of the ten sample locations from the first two applications met the soil remediation goal of 16 mg/kg established for this site. (Pretreatment surface soil concentrations ranged from 39 to 1,500 mg/kg, while post-treatment concentrations ranged from 17 to 680 mg/kg. For soil samples collected from a depth of 1.5 to 2 feet below grade, pre- and post-treatment concentrations of Cr(VI) were 7.9 mg/kg and 3.2 mg/kg, respectively.) The remediation goal of 16 mg/kg is currently being re-evaluated by Region IV EPA and may be increased (ABB, 1998a).

Two separate treatment tasks and two full-scale injections related to *in situ* groundwater remediation have been conducted at the site thus far. The first treatment task consisted of a small-scale injection of ferrous sulfate reagent into a single vertical injection well in the area where the original source of groundwater contamination was located. Because the first treatment task was situated in an area having relatively low Cr(VI) concentrations (0.2 to 0.3 mg/L), a second treatment task, also consisting of a small-scale injection of ferrous sulfate reagent into a single vertical injection well, was conducted in an area of highest groundwater contamination [2 to 4 mg/L of Cr (VI)]. The data obtained from the first two groundwater treatment tasks were used to design the first full-scale injection, which was situated along the upgradient edge



of the plume. Data obtained from the first full-scale injection was then used to plan the second full-scale injection, which was situated approximately 200 feet downgradient of the first injection.

In the first treatment task, an acidic ferrous sulfate reductant solution was introduced into the subsurface via the vertical injection well using the existing sprayfield piping network and chemical feed system to evaluate its effect on groundwater at the Townsend Saw Chain site. A chloride tracer was also utilized during the test to monitor the progression of the reagent plume. The injection of ferrous sulfate solution into the aquifer plume was successful in reducing total and Cr(VI) concentrations in groundwater to below the remediation goal of 0.1 mg/L. After treatment, initial groundwater concentrations up to 0.38 mg/L were effectively reduced to less than 0.04 mg/L. Concentrations of sulfate, chloride, and total and ferrous iron were elevated during treatment due to their introduction into the aquifer but steadily returned to pretreatment levels after treatment. The concentration of total chromium initially increased in the aquifer during treatment, most likely due to the displacement of sorbed Cr(VI) ions from the aquifer matrix by sulfate ions. This test was limited to groundwater containing relatively low concentrations of Cr (VI), between 2 and 3 times the treatment standard of 0.1 mg/L. A second injection test was planned in an area expected to contain the highest concentrations of Cr(VI) to evaluate treatment effectiveness in high-concentration areas (ABB, 1998b).

The second treatment task utilized one vertical injection well and a network of six monitoring wells. Overall, only limited data were obtained during the second treatment task, as compared to the first task, due to an unexpected flow path observed in the vicinity of the extraction well. The reagent plume did not follow the expected linear path to the extraction well, but rather followed an arched path around the downgradient monitoring wells. However, the data that was collected provided confirmation that Cr(VI) was again successfully treated to

below the remediation goal. Results also indicated that approximately 10 feet of vertical dispersion was achieved.

Based on data generated during the two, small-scale, treatment tasks and an engineering evaluation that identified the most effective and feasible method of injection, the initial phase of full-scale treatment of groundwater was designed and constructed. Data from the small-scale tasks indicated that, at a minimum, a 20-foot spacing for injection wells would effectively provide for lateral dispersion of the reagent. However, to provide the most feasible alternative for injection, a 40-foot spacing of vertical injection wells was preferred. To evaluate the effectiveness of lateral dispersion using a 40-foot spacing, ferrous sulfate solution was initially only injected into every other injection well during the first full-scale injection. After the first six weeks of post-injection monitoring, data suggested that injection at 40-foot centers was not effective in dispersing the reagent. Therefore, injection into the remaining wells was initiated to provide data to complete an evaluation of full-scale treatment effectiveness.

However, in the same week that the second injection was initiated, a trend of increasing sulfate concentrations in the first four dispersion wells was confirmed. The increasing sulfate concentrations in dispersion wells indicated that the reagent plume, although exhausted (i.e., lacking ferrous iron), had successfully reached the dispersion wells. Thus, the 40-foot spacing of injection wells appeared to be effective in laterally dispersing the reagent into the aquifer. Although the injection was successful in laterally dispersing the reagent, effective treatment over the entire width of the treatment cell was not accomplished due to the exhaustion of the reagent. The exhaustion appeared to be due to the buffering capacity of the aquifer in the vicinity of the injection wells. According to EPA, it was later determined that the buffering capacity in this location had probably been altered due to the past application of high pH effluent water via spray field from an electrochemical precipitation treatment system

for pumped contaminated groundwater. Therefore, it is anticipated that the downgradient aquifer buffering capacity will not be as high (will be normal for the site) and reagent exhaustion will not be a significant problem for the rest of the site (Howard, 2000).

A second, full-scale injection was then conducted to attempt to overcome the buffering capacity of the aquifer. During the second injection, a larger volume of acidified reagent was injected into the aquifer (over a 30-day period). The pH of the injection solution was also lowered from approximately 3.0 to 2.5 to help overcome the buffering capacity. Unfortunately, during the second injection, the aquifer continued to buffer the reagent, causing the iron to precipitate. Furthermore, due to the mass of iron precipitate accumulating in close proximity to the injection wells, back pressure within each well increased significantly (Tremaine, 1999). Iron precipitation and clogging is a potential complication of treatment using a ferrous sulfate-based reductant. This second, full-scale injection was later repeated (August, 1999) at a downgradient location. Data collected over four weeks of monitoring indicates that effective treatment occurred at a distance of at least 37 feet downgradient of the injection line, and that good lateral dispersion occurred. Based on this data, it is expected that with additional injection of reductant, effective treatment at the 100-foot distance will be achieved (Harding Lawson Associates, 1999).

The remedial design for surface soils and groundwater treatment at this site is based on the treatment tasks conducted during the remedial planning phase. For surface soils, approximately 2,400 yd<sup>3</sup> of soil containing Cr(VI) above the current remediation goal of 16 mg/kg were identified in the ROD for the site. This surface soil may be treated using surface application of reductant. However, EPA is reviewing the current remediation goal and may elect to change it to a recently proposed value of 144 mg/kg. This value is based on evidence developed during the remedial design which does not show the expected leaching of Cr(VI) to groundwater. EPA is preparing an

Explanation of Significant Difference that will incorporate the revised remediation goal (Howard, 2000). If the higher value of 144 mg/kg is approved, a much smaller volume of surface soil will be contaminated above this level. In this case, approximately 60 yd<sup>3</sup> of contaminated surface soils may be excavated and disposed off-site (Harding Lawson Associates, 2000).

Groundwater will be treated *in situ* by injecting reductant into a series of injection wells placed along a line that transects the width of the plume. Injections will start at the upgradient portion of the plume and proceed in the downgradient direction. Injections along each subsequent injection line will be initiated after monitoring data from the upgradient injection indicate that the entire treatment cell will be effectively treated. Injection lines will be spaced to ensure capture of any ferrous sulfate reagent by the existing extraction well network and minimize the potential for contamination of a seep area and downgradient surface water bodies. It is anticipated that high ferrous iron (150 to 250 mg/L) and sulfate concentrations (700 mg/L), and low pH will occur as a result of chemical treatment. Therefore, capture of treated groundwater and excess reagent will be important to prevent any negative off-site impacts. Sulfate is expected to naturally attenuate to concentrations below the national secondary drinking water standard of 250 mg/L. However, contingencies including predicting potential breakthrough by modeling mass loadings, and off-site groundwater monitoring for early warning of sulfate breakthrough will be utilized to help prevent off-site contamination of surface water (Harding Lawson Associates, 2000).

Based on an evaluation conducted during treatment tasks, the potential for re-oxidation of Cr(III) at the site appears to be minimal. However, to ensure that re-oxidation of Cr(III) will not occur, several studies will be undertaken during the remediation to assess the long-term stability of the chromium reduction (Harding Lawson Associates, 2000).

Other potential risks or uncertainties for groundwater remediation using ferrous sulfate reductant at this site, and their proposed resolution, are as follows (Harding Lawson Associates, 2000):

- Small-scale heterogeneities may be present within the treatment cells. Lithologic data will be used to evaluate the potential presence of any areas of gross heterogeneity (e.g., areas of high clay content). Flow rates and injection pressures will be managed according to general permeability characteristics of the aquifer media.
- Pre-acidification will be conducted and the pH drop will be monitored prior to and subsequent to each ferrous sulfate injection. Areas of high buffering capacity where the pH is difficult to adjust may require additional pre-acidification prior to treatment.
- Iron fouling may occur in or in the vicinity of injection wells. Pre-acidification prior to ferrous sulfate injection, and quality control of the injected reagent, will be employed to help reduce or prevent iron fouling. The use of larger diameter (2-in) injection wells should also reduce iron fouling in the wells.
- “Clogging” of the aquifer from the formation of the solid iron-chromium hydroxide complex may decrease the yield and supply of make-up water from on-site extraction wells. Other source areas of groundwater upgradient of the spray fields, or a potable water supply, may be used for make-up water.

Implementation of the full-scale groundwater remedial action began in late 1999 and is currently ongoing. Preliminary monitoring data indicate that the treatment process is effectively reducing Cr(VI) concentrations to less than the remediation goal (MCL) of 0.1 mg/L in most locations. Some monitoring locations are not being effectively treated and have Cr(VI) concentrations above the MCL. This contamination appears to be spatially limited and may require spot-treatment to fully remediate

(Harding Lawson Associates, 2000). As expected, sulfate levels in groundwater have increased due to the injection of ferrous sulfate reagent. Data are not yet available to determine if post-treatment sulfate levels return to pre-injection levels or if sulfate migration outside the treatment capture zone(s) is occurring.

It has been estimated that approximately 563,000 cubic yards of saturated zone material requires remediation of groundwater to below the regulatory limit of 0.10 mg/L Cr(VI). The remedial action cost estimate for the groundwater remedy at this site is \$1,677,800 (Harding Lawson Associates, 1999). This results in a cost of approximately \$3 per cubic yard, but does not include costs for the preliminary treatment tasks. A cost estimate for treatment of surface soils was not available since the remedy had not been finalized.

## 3.2 PRBs (Treatment Walls)

### 3.2.1 Technology Description

PRBs provide *in situ* treatment of groundwater emitting from source zones (Vance, 1997). They are designed as preferential conduits for contaminated groundwater flow (U.S. EPA, 1997a). These reactive barriers differ from the highly impermeable barriers, such as grouts, slurries, or sheet piling, which have previously been used to restrict the movement of chromium-contaminated groundwater plumes. PRBs can be installed as permanent, semi-permanent, or replaceable units across the flow path of a contaminant plume and act as a treatment wall. Natural hydraulic gradients transport contaminants through the strategically placed reactive media (U.S. EPA, 1996b). When the contaminated water passes through the reactive zone of the barrier, the contaminants are either immobilized or chemically transformed to a more desirable (e.g., less toxic, more readily biodegradable, etc.) state (U.S. EPA, 1997a). In the case of chromium, it is immobilized by precipitation onto reactive media or aquifer solids. PRBs are not currently used to directly remediate contaminant source areas, only to intercept and treat

contaminant plumes. The installation, design, and reactive media for PRBs are discussed in the following text.

PRBs are installed downgradient of a source zone, vertically intersecting the contaminated groundwater flow. They can be installed with trenching, if the targeted portion of the aquifer is shallow and surface improvements do not interfere with access. They can also be installed by well injection. Injection through standard vertical wells is the least expensive option but horizontal borings can be installed beneath existing structures and are able to create a uniform reactive zone. This is more difficult to achieve through vertical wells (Nyer and Palmer, 1997). Most health and safety issues regarding PRBs are mainly associated with installation of the wall, and will vary according to the method of installation used. Environmental impacts from treatment wall installation, as well as maintenance, may be less than with other technologies due to the placement of all treatment materials underground, with minimal disturbance to surface activities (Vidic and Pohland, 1996).

Two basic designs are being used in full-scale implementation of reactive barriers: (1) funnel-and-gate, and (2) continuous trench. These designs are depicted in Figures 3-4a and 3-4b (U.S. EPA, 1997a). Basically, for the funnel-and-gate system, an impermeable funnel, typically consisting of interlocking sheet pilings or slurry walls, is emplaced to enclose and direct the flow of contaminated water to a gate or gates containing the permeable zone of reactive media. Due to directing large amounts of water through a much smaller cross-sectional area of the aquifer, groundwater velocities within the barrier will be higher than those resulting from the natural gradient. Sheet pilings eliminate the removal of soil and reduce the soil disposal cost. Depending on the type of slurry wall, some portion of the excavated soil may be incorporated into the wall; however, soil disposal costs must be taken into account for these types of funnels. Due to aquifer heterogeneity and to

minimize groundwater mounding, a low funnel-to-gate ratio is preferred. In order to assure complete capture of the plume, the length of a funnel-and-gate system is typically 1.2 to 2.5 times the plume width depending on the funnel-to-gate ratio and the number of gates.

The funnel-and-gate configuration also allows for reactive material to be more easily replaced; however, field experience indicates funnel-and-gate is more susceptible to hydraulic uncertainties which cause bypass of flow around the system (O'Hannesin, 1999). The continuous trench is simply a trench that has been excavated and simultaneously backfilled with reactive media, allowing the water to pass through the barrier under its natural gradient (USEPA, 1997a). A continuous trench distributes the reactive material across the entire path of the contaminated groundwater. Of the alternatives, this configuration is least sensitive to complexities in the flow field and does not significantly alter the natural groundwater flow path (O'Hannesin, 1999).

### ***Installation***

In more shallow areas (less than 35 ft) conventional excavation and replacement methods are typically utilized for PRB installation. These methods are typically less expensive than those implemented deeper into the subsurface. For deeper installation, excavation and replacement can be costly and are often influenced by the need to excavate to considerable depths through uncontaminated soil before reaching the plume. Several construction methods are available to accommodate the various configurations at shallow depths. The least expensive trenching method is backhoe trenching, which can be implemented if the formation soil does not cave in; however, the limitation is the excavation width. A continuous trenching machine, which is currently limited to depths of less than 35 ft, allows for simultaneous excavation and backfilling without an open trench, and it allows for very rapid installation; however, it has

## Conceptual Configuration of PRB

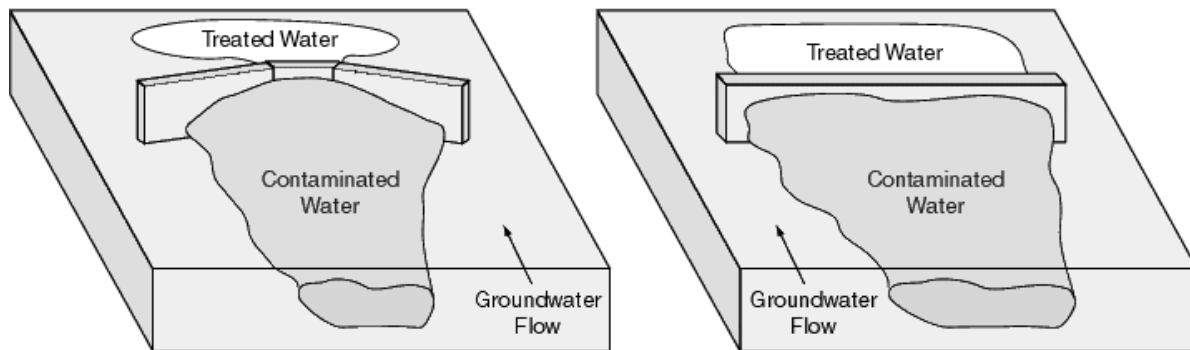

Source: USEPA, 1997a

**Figure 3-4a Plume capture by a funnel-and-gate system. Sheet piling funnels direct the plume through the reactive gate.**

**Figure 3-4b Plume capture by a continuous trench system. The plume moves unimpeded through the reactive gate.**

considerably larger equipment and slightly higher mobilization costs. Another common installation method is *cofferdam or sheet pile excavation boxes* that are formed and braced using interlocking sheet piling. The sheet piling maintains the dimensions of the treatment zone during excavation and backfilling. After backfilling is complete, the sheet piling is removed and the groundwater is allowed to flow through the treatment zone. Trench boxes, like sheet piling, are used to maintain trench integrity during excavation and backfilling operations. *Auger holes* have also been utilized to install treatment zones. Rotating a continuous flight of hollow stem augers into the required depth, the reactive material can be placed through the auger stem as the augers are removed. These treatment zones can be created by overlapping holes or in well arrays where two or more rows are required. Methods for deeper installations are also being used or researched and evaluated. *Caisson* installation involves driving a large circular steel caisson into the ground and augering out the native material. The caisson is then backfilled with a reactive material and removed. Overlapping or tangential caisson emplaced treatment zones can be used to create a larger permeable treatment zone. However, the overlapping caissons cause wastage of iron ranging from

10 percent to as high as 30 percent. A *mandrel or H-beam* is a hollow steel beam with a disposable shoe at the leading edge that is driven into the ground to create a thin continuous treatment zone. Once the mandrel reaches the maximum depth of the treatment zone, the reactive material is placed inside the mandrel and the disposable shoe is removed. This process is then repeated creating a continuous zone of reactive material. In previous applications, parallel treatment zones were created to provide sufficient reactive material and to reduce the risk that the contaminants would not come in contact with the reactive material.

Another installation method that has been proposed at several sites, but has not been used to date, is *ground freezing* which has been implemented in the construction industry for many years, and involves the use of refrigeration to convert *in situ* pore water into ice. The ice acts as a bonding agent, which fuses together particles of soil to increase the strength of the mass, and makes it impervious. Excavation can be performed safely inside the barrier of water-tight frozen earth with conventional excavation equipment. One deep installation method requires that the reactive materials be carried in a *biodegradable slurry (bioslurry)*, usually guar.

This method has been employed in the construction industry for years, and is currently being modified to implement PRBs along with various reactive materials deep into the subsurface. As part of pre-construction activities, tests to determine that the site water chemistry is compatible with the reactive material and bioslurry mixture, and to assure that the bioslurry breaks down over a suitable time period at groundwater temperatures, should be undertaken. Additional testing should also be undertaken to determine the effectiveness of the reactive material once it has been in contact with the bioslurry (O'Hannesin, 1999). A bioslurry trench installation is similar to constructing a conventional impermeable slurry wall. As the trench is excavated, bioslurry provides stability to the trench walls, and the reactive material is placed via a tremmie tube into the trench. Minimal contact should be made between the reactive material and bioslurry (O'Hannesin, 1999).

*Vibrated beam technology* has been used for years to install thin impermeable slurry walls and recently has been adapted to inject reactive material and bioslurry. The large I-beam is driven into the subsurface and as the beam is vibrated out, a reactive material and bioslurry is pumped into the formation, filling the void created by the beam. This process is then repeated and several lines in parallel can provide the required amount of reactive material (O'Hannesin, 1999).

*Deep soil mixing* has been suggested where the reactive material is mixed with biodegradable slurry and pumped to the mixing augers while they are being advanced slowly through the soil. Over time the bioslurry breaks down allowing the groundwater to flow through the reactive material and aquifer mixture or treatment zone. High costs are associated with mobilization and demobilization for deep soil mixing (O'Hannesin, 1999).

Two other deep installation methods that have been successfully demonstrated in the field are *jetting and vertical hydrofracturing*. Jetting uses high pressure to inject fine-grained reactive material into the natural aquifer formation. The jetting tool is advanced into the formation to the desired depth, then the reactive material and bioslurry are injected through the nozzles as the tool is withdrawn. Either columnar zones or diaphragm walls can be created. Vertical hydrofracturing uses a specialized tool to orient a vertical fracture and initiate the fracture process. The tool is placed to the desired depth through a borehole and the interval for fracturing is isolated by packers. The reactive material and bioslurry are then pumped under low pressures into the formation to form a thin vertical plume along the line of the induced vertical fracture (O'Hannesin, 1999).

### **Site Characterization**

In order to successfully install a PRB, a thorough site characterization must be conducted. The entire plume must flow through and react with the reactive media. It must not be able to pass over, under, or around the barrier and the reactive zone must be capable of reducing the contaminant to concentration goals without rapidly plugging with precipitates or losing its reactivity. To achieve this success, knowledge is required of:

- Plume locations
- Plume direction
- Contaminant concentrations
- Hydrologic changes with time
- Concentration attenuation over time and distance
- Stratigraphic variations in permeability
- Confining layers
- Fracturing
- Aqueous geochemistry

Barrier design, location, emplacement methodology, and estimated life expectancy are based on the site characterization information; therefore, faulty information could jeopardize the entire remedial scenario.

Monitoring for regulatory compliance and treatment performance are both necessary when using PRBs. Compliance monitoring determines whether regulatory contaminant concentrations are being met.

### **Reactive Media**

Most permeable reactive barriers use reactive iron metal to treat chromium waste. Cr(VI) as chromate has been shown to be reduced by zero-valent reactive iron (Fe<sup>0</sup>). The Fe<sup>0</sup> donates the electrons necessary to reduce the chromate and becomes oxidized to Fe(II) or Fe(III). When iron is present, the Cr(III) can precipitate as a mixed chromium-iron hydroxide solid solution, which has a lower solution equilibrium activity than pure solid-phase hydroxide. Therefore, both the toxicity and mobility of chromium are greatly decreased when it is reduced from Cr(VI) to Cr(III) (U.S. EPA, 1997a). This reduction can be described by the overall reaction:

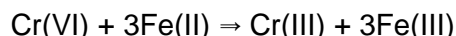

This reaction appears to be appropriate for pH values less than 10 and for phosphate (PO<sub>4</sub>) concentrations less than 0.1mM. Above pH 10, the rate of oxidation of the ferrous iron by dissolved oxygen is greater than the rate of oxidation of ferrous iron by CrO<sub>4</sub> (Walker, 1999).

Work at one contaminated site has shown sodium dithionite is capable of reducing Fe(III) to Fe(II), which in turn reduces Cr(VI) to Cr(III). Experiments have also shown that the half-life of dithionite is 2 to 3 days in the site's confined aquifer. This half-life is adequate for reducing the contaminants in the plume, while ensuring that dithionite does not remain as a contaminant in the groundwater for an extended time (U.S. EPA, 1995a). This discovery has been one of several steps

towards more effective utilization of Fe<sup>0</sup> PRBs in chromium remediation.

Dithionite is a sulfur-containing oxyanion which breaks down quickly in aqueous solution to form two sulfoxyl radicals. These radicals react rapidly to reduce ferric iron in minerals and oxides which occur naturally in most aquifer sediments. Amonette et al. (1994) have shown that, within the aquifer, the injected dithionite reacts with structural iron in oxyhydroxide and iron-bearing layer silicate mineral phases, reducing Fe(III) to Fe(II) according to the overall reaction described by Equation 1:

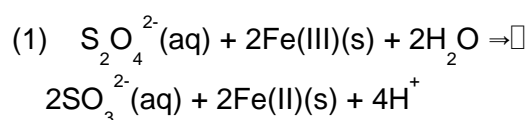

The reduced sediments in the treatment zone can remove redox-sensitive contaminants from groundwater flowing through the zone. Within the zone of dithionite-reduced sediments, aqueous chromate reacts with Fe(II) produced by the dithionite reaction (Equation 1) and is precipitated as a solid hydroxide (e.g. Cr(OH)<sub>3</sub>) according to the example reaction described in Equation 2:

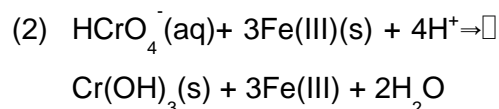

The majority of PRB remediation techniques discussed at symposiums today focus on the use of granular iron filings (Fe<sup>0</sup>) as the reductant of choice (Cercona, 1995). Fe<sup>0</sup> can also be used to dechlorinate trichloroethene (TCE) (U.S. EPA, 1997a).

Iron filings are relatively inexpensive and are available in coarse particulate sizes that result in packing densities less than 50 percent of theoretical; therefore, it is easily shipped to sites. The use of these materials in particulate form presents materials-handling difficulties, particularly when the process is being conducted *in situ* and an absorbent material must be removed from the ground after it has become fully "loaded" with the contaminant.

A ceramic foam process has an advantage over packed iron filings due to its monolithic nature. The blocks of foam can be easily handled and mounted in a frame or cassette or strung like beads on a wire to facilitate placement and removal. Densities of the foamed material can be adjusted to increase compressive strength to withstand geostatic loads (Cercona, 1995).

Foams are made with relatively high surface

(Bowman et al., 1999). Natural zeolites can be treated with cationic surfactants to alter their surface chemistry and improve their affinity for sorption of anionic metals such as chromium. In addition, zeolites can be combined with Fe<sup>0</sup> to create the combined effect of adsorption and reduction. This may lead to a decrease in the amount of material required to achieve a given level of Cr(VI) removal (Zhaohui, 1999).

**Table 3-3. Comparison of Granular vs. Foam Iron Reactive Media for PRBs**

	Granular Iron	
<b>Size/Packing Density</b>	20-40 mesh 42 to 45 percent 212 lbs/ft <sup>3</sup>	10 to 15 percent of theoretical 60 to 75 lbs/ft <sup>3</sup>
<b>Surface Area</b>	1.1 m <sup>2</sup> /g specific surface area 105,870 m <sup>2</sup> /ft <sup>3</sup>	Greater than 4 m <sup>2</sup> /g Greater than 120,000 m <sup>2</sup> /ft <sup>3</sup>
<b>Raw Material/Unit Cost</b>	\$75/ft <sup>3</sup> 1,400 m <sup>2</sup> /\$	\$1/lb \$60 to \$75 1,600 to 2,000 m <sup>2</sup> /\$
<b>Typical Excavation Cost</b>	\$500,000 for 2,000 ft <sup>3</sup> gate	Low

concentrations with metallic iron contents between 92 and 94 percent and high specific surface areas exceeding 5 m<sup>2</sup>/g. The development of foams has focused on maximizing surface area, iron purity content, and the possible incorporation of secondary materials that could improve the rate of adsorption/immobilization of heavy metals. Table 3-3 shows a comparison of granular iron and iron foam (Cercona, 1995). The use of granular iron has been more typical for PRB applications.

Zeolites are also being evaluated as an adsorbent material for use in PRBs. Zeolites have large specific surface areas, high adsorption capacities, high CECs, good hydraulic characteristics, and relatively low cost

Biotic applications such as biomineralization can also be accommodated with the PRB approach to treatment of chromium contaminated groundwater. A biomineralization application is discussed in Section 3.3.

#### Advantages

- Actual *in situ* contaminant remediation.
- Passive remediation, no ongoing energy input and limited maintenance following installation; reduced operation and maintenance (O&M) costs compared to pump-and-treat.
- No required surface structures other than monitoring wells following installation.
- Can remediate plume even when the source of the plume cannot be located.



- Should not alter the overall groundwater flow pattern as much as high-volume pumping.
- Contaminants are not brought to the surface; i.e., no potential cross-media contamination.
- No disposal requirements or disposal costs for treated wastes.
- Avoids mixing of contaminated and uncontaminated waters that occurs with pumping.
- Foams have the capability to be a “customized” system.
- Foams have a very high specific surface area.
- Foams have a tailored pore size and high permeability/porosity, which controls mass transport capabilities.
- Foams have a controlled composition.
- Foams have the potential for easy retrieval (if necessary) and if they are retrieved, their volumes can easily be reduced for disposal.

**Limitations**

- Currently restricted to shallow plumes, approximately 50 ft or less below ground surface.
- Plume must be very well characterized and delineated, for example, no fractured rock or excessive depth to contaminant plume.
- Limited long-term field testing data is available and field monitoring is in its infancy.
- Limited field data concerning longevity of wall reactivity or loss of permeability due to precipitation.

- Currently no field-tested applications to remediation of contaminant source areas.
- Blockage of the pore space with products of reaction processes, particularly with injection based systems.
- Does not allow the degree of aquifer hydraulic control of active approaches like pump-and-treat.

**3.2.2 Status**

EPA recognizes PRBs as a technology with the potential to more effectively remediate subsurface contamination at many types of sites at significant cost savings compared to other more traditional approaches. It is actively involved in the evaluation and monitoring of this new technology to answer questions regarding long-term system performance, and to provide guidance to various stakeholder groups (USEPA, 1997a).

The Waterloo Centre for Groundwater Research has developed *in situ* PRBs for treatment of inorganic contaminants, including chromium, at several sites in Canada and the U.S. Inorganic contaminants in groundwater are treated using *in situ* porous reactive walls.

Treatment wall materials are placed in the path of the plume and react with the contaminant via reduction and precipitation. Preliminary results of field trials indicate contaminant concentrations were decreased by orders of magnitude and to below drinking water levels (U.S. EPA, 1995a).

As of April 1997, there were 124 treatment wall projects identified for all classes of site contaminants. Fe<sup>0</sup> was employed as the reactive media in 45 percent of the 124 projects. For inorganic contaminant projects, 31 percent involved the remediation of chromium (Sacre, 1997).

Figures 3-5 and 3-6 show the breakdown of inorganic contaminants addressed by PRBs and the types of projects addressing chromium remediation (Sacre, 1997).

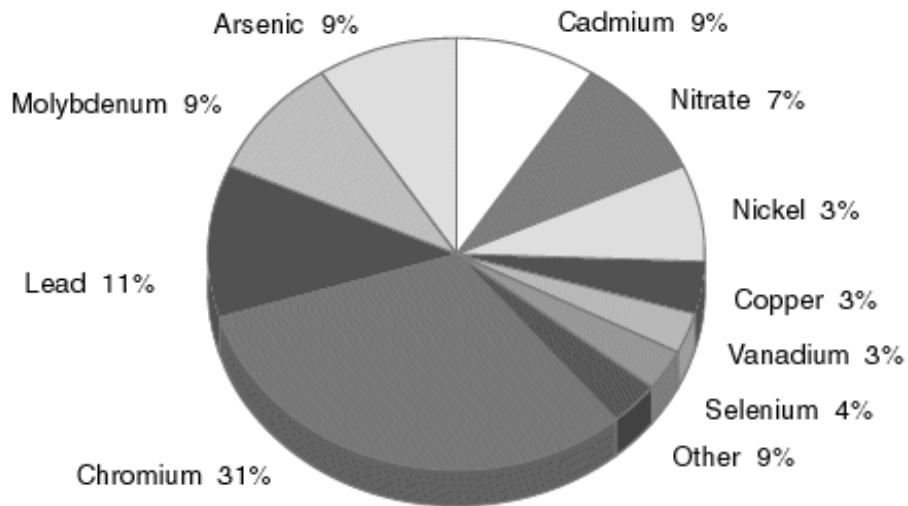

**Figure 3-5 Breakdown of inorganic contaminants addressed by PRBs.**

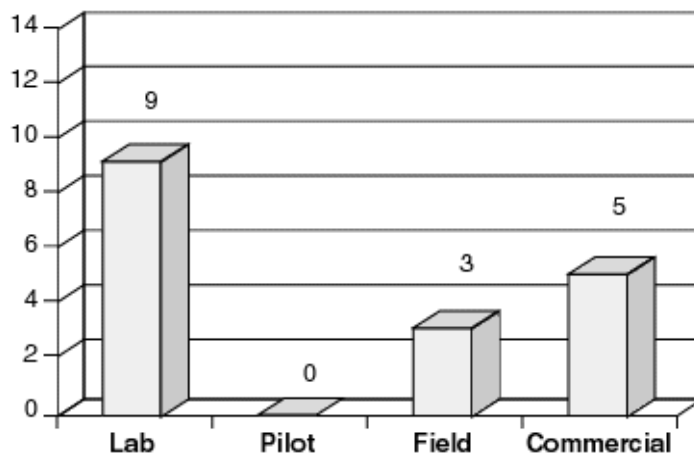

**Figure 3-6 Breakdown of types of PRB projects addressing chromium remediation.**

A Permeable Barriers Action Team (PBAT) was established in March 1995 as part of EPA's Remediation Technologies Development Forum (RTDF). The mission of the PBAT is to accelerate the development of cost-effective PRB technologies. Its efforts focus on defining the hydraulics, geochemistry, and reactions occurring in the media and aquifers; demonstrations that validate the technology's effectiveness; protocols for design and implementation; effective emplacement technologies and configurations; economic analysis of treatment costs; and public and regulatory acceptance of technology (USEPA, 1996b).

### **3.2.3 Performance and Cost Data**

The costs of the impermeable sections of the treatment wall system can be obtained from experiences with slurry walls or sheet pile installations. If the reactive media is  $\text{Fe}^0$ , the cost of the media can be estimated based on the density of about  $2.83 \text{ kg/m}^3$  and a cost of approximately \$350 to \$450/ton. A 1996 review suggested that installation costs between \$2,500 and \$8,000 per L/min of treatment capacity can be used as a rule-of-thumb for estimating the capital cost of these systems. Since zero-valent treatment walls is a patented technology, a site licensing fee, which has been typically 15 percent of the capital costs (materials and construction costs), may also be required (Vidic and Pohland, 1996).

Using continuous trenching machine installation, costs range from \$200 to \$400 per linear foot (Puls, 2000). The sheet pile excavation boxes average about \$80  $\text{ft}^2$  and trench boxes range about \$10 to \$20 per  $\text{ft}^2$ .

Caisson implementation averages about \$200 per vertical foot, and a mandrel installation ranges from \$10 to \$20 per  $\text{ft}^2$ . A bioslurry trench can be installed for \$15 to \$25 per  $\text{ft}^2$ .

The vibrated beam method can be installed on the order of \$10 per  $\text{ft}^2$  and deep soil mixing cost can range from \$75 to \$120 per  $\text{yd}^3$ . To utilize the jetting method may cost on the order of \$75 per vertical foot (O'Hannesin, 1999).

A principal advantage of PRBs over other groundwater remediation approaches is reduced O&M costs. Other than groundwater monitoring, the major factor affecting O&M costs is the need for periodic removal of precipitates from the reactive media or periodic replacement or rejuvenation of the affected sections of the permeable wall. O&M costs between \$1.3 and \$5.2 per 1,000L of treated water can be used as a rule-of-thumb for estimating the O&M costs of these systems (Vidic and Pohland, 1996).

A cost analysis conducted by Manz and Quinn (1997) indicates that use of PRBs can result in significant cost savings over a comparable groundwater extraction and treatment system. In their study of two sites, they indicate that while capital costs vary, the annual estimated operation and maintenance costs for a treatment wall were between \$20,000 and \$27,120, as compared to between \$55,000 and \$100,000 for a pump-and-treat system. However, actual cost savings depend on the initial capital costs for the barrier installation and the estimated longevity of the reactive barrier.

Depending on the scale of analytical monitoring required, operational costs for a PRB may be 70 to 90 percent less than the cost of a pump-and-treat system per year. This is due to the fact that no provision is necessary for the disposal of recovered water and the system is mechanically passive (Vance, 1997).

There are several sites which currently employ PRB technology for chromium remediation. Some of these applications are discussed in the following text.

### ***Elizabeth City, North Carolina PRB***

An integrated technical demonstration program for chromium remediation was established at a U.S. Coast Guard (USCG) facility in Elizabeth City, North Carolina which operated a chrome plating shop for 30 years. Activities at this facility resulted in the release of chromic acid into the soils below the shop. A detailed characterization of the underlying soils and groundwater of the chrome plating shop was performed to provide information on the extent of contamination at the site and the potential for off-site migration and environmental impact (Khan, 1999).

Installation of the PRB at this site involved two phases; a pilot-scale field test and a full-scale field demonstration (U.S. EPA, 1997). In the pilot-scale field test, two types of reactive iron were mixed in equal volumes with coarse sand and native aquifer material on-site and poured through hollow stem augers drilled to the appropriate depth. Frequent geochemical monitoring of groundwater in the test zone was performed to assess the removal of dissolved chromate from the groundwater and to confirm or elucidate the proposed chemical mechanisms responsible for remediation. Results from the September 1994 field pilot test in Elizabeth City indicated that complete treatment of chromium in the groundwater might be possible at this site. Chromium concentrations at this site were reduced to less than 0.01 mg/L, below the drinking water limit, according to the researchers (Puls et al., 1999).

The full-scale field demonstration consisted of laboratory and batch column tests to determine the granular iron mixture best suited for simultaneously treating Cr(VI) and TCE contaminated groundwater; three-dimensional groundwater flow simulations to assess the relative efficiency of a funnel-and-gate versus

a continuous wall design; design and installation of the selected reactive barrier; performance monitoring of the installed barrier; and multicomponent reactive transport modeling (U.S. EPA, 1999a, 1999b, and 1999c).

Groundwater plumes at the Elizabeth City site contained Cr(VI) and TCE in excess of MCLs (greater than 5 and 10 mg/L, respectively). The release of Cr(VI) to the subsurface resulted in the development of a well-defined plume of groundwater containing Cr(VI) concentrations in excess of 28 mg/L near the source. An extensive plume of TCE overlaps the Cr(VI) plume. Based on the preliminary studies, a full-scale continuous wall PRB demonstration system was installed at the same Elizabeth City, North Carolina site on June 22, 1996. The continuous wall design was selected because for the Elizabeth City site, there were no hydraulic advantages of a funnel-and-gate design in terms of both increased capture area and increased residence time.

The full-scale barrier was comprised entirely of Fe<sup>0</sup>, in the form of iron filings. The reactive media was selected based on suitable reaction rates, desirable hydraulic properties, and lower cost. The installed reactive barrier was 46.0 m long, 5.5 m in depth, and 0.6 m wide. The dimensions were selected to ensure capture of the full horizontal extent of the Cr(VI) and TCE contaminated plumes, and to prevent penetration of a fine-grained geologic unit present at approximately 8 m depth. The reactive barrier was installed in less than 8 hours using a continuous trenching technique. The total cost of the reactive barrier at Elizabeth City including site assessment, design, construction, materials, and preliminary and follow-up work, was approximately \$985,000. The installation and granular iron costs were estimated to be approximately \$350,000. These capital costs were estimated to be comparable

to a pump-and-treat system. However, annual O&M costs are estimated to be \$32,000 for the reactive barrier compared to \$200,000 for a pump-and-treat system (USEPA 1999a).

A detailed monitoring network was installed in the vicinity of the PRB in November 1996. Three rows of bundle-type piezometers with up to 11 sampling ports, ranging in depth from near the water table to 7 m, and 9 conventional 2-in polyvinyl chloride (PVC) monitoring wells were utilized for performance and compliance monitoring, respectively. Water samples were collected from the sampling points and immediately analyzed to determine pH, Eh, electrical conductivity, turbidity, alkalinity, dissolved oxygen, Cr(VI), total sulfide, and Fe(II). Dissolved and total inorganic constituents were analyzed. Groundwater monitoring was conducted seven times between November 1996 and December 1998 (USEPA, 1999b).

The reactive barrier was designed to meet the cleanup goal concentration of 0.05 mg/L Cr(VI). Results from the monitoring network established in November 1996 indicate that all Cr(VI) has been removed from the groundwater within the first 6 in of the reactive barrier. Chlorinated hydrocarbons decreased by more than 95 percent, with most multilevel samplers showing reductions below MCLs (USEPA, 1999). No chromium or Cr(VI) has been detected above MCLs downgradient of the wall either in the multilevel sampling ports or in the compliance wells located immediately behind the barrier. TCE concentrations were reduced by orders of magnitude within the barrier, although TCE concentrations of up to 15 µg/L were observed downgradient in two compliance wells, above the MCL of 0.5 µg/L.

These elevated downgradient TCE concentrations were possibly due to a portion

of the TCE plume going underneath the barrier wall and therefore receiving inadequate treatment. The pH increased from background values of pH 6 to 7 to values of 9.0 to 10.5 within the reactive barrier, and then fell to background values within 2 m downgradient of the iron wall. The Eh showed a corresponding sharp decline, from background values of 100 to 500 mV to very low values of -400 to -600 mV within the reactive barrier. The Eh rose again downgradient of the reactive barrier. Low Eh and high pH values within the reactive barrier indicate that conditions were suitable for the reduction of Cr(VI), the precipitation of Cr(III) oxyhydroxides, and the reductive dechlorination of TCE. The alkalinity values decreased from background values between 40 and 100 mg/L (as calcium carbonate - CaCO<sub>3</sub>) to <10 mg/L (as CaCO<sub>3</sub>) within the reactive barrier, which may be the result of carbonate mineral precipitation (U.S. EPA, 1999b).

The precipitation of secondary minerals within the barrier may have an important impact upon the long-term performance of the barrier. Slug tests performed in February 1997 indicate that the hydraulic conductivity of the granular iron was still significantly greater than the hydraulic conductivity of the aquifer. Reactive transport modeling was used to look at the precipitation of secondary minerals and their effect on long-term performance efficiency, as well as other aspects of treatment. The model results indicate that over a long period of time, porosity may decrease significantly, which will almost certainly affect the hydraulic properties of the treatment system. The reactivity of the treatment material may also decline over time which could reduce the contact time of the contaminants with the treatment material. This may lead to the incomplete treatment of contaminants that require a long residence time (U.S. EPA, 1999c).

Four iron foam samples with various compositions, densities, and specific surface areas were also tested at the Elizabeth City site. Two of the samples showed positive results for chromium removal. Following these results, additional samples were requested for more specific evaluations. It was found that the inclusion of aluminosilicate materials helped control the reaction kinetics by buffering the pH of the groundwater associated with the iron reduction reaction. If the pH of the system was allowed to approach 9.5 to 10.0, the reaction kinetics were slowed. When aluminosilicates were present, the pH of the system remained under 8. The additional samples being tested at this site were used to determine the benefits of an iron foam containing the aluminosilicate (Cercona, 1995).

### ***Hanford, Washington In Situ Redox Manipulations (ISRM)***

Following years of weapons production at the U.S. Department of Energy (DOE) Hanford site in south central Washington State, numerous groundwater plumes are currently impacting the Columbia River. Pump-and-treat systems are operating at two of the plumes. Because PRBs have proven elsewhere to be more effective than these methods, DOE opted to test these on a third plume. Since the plumes average about 80 ft below the surface, ISRM was used as an alternative to “trench and fill” because it can be applied through conventional groundwater wells. The ISRM approach extends the permeable treatment zone concept to sites where the groundwater contaminant plumes are too deep to be treated by excavation or by trench–emplaced permeable barriers (Fruchter, 1999).

ISRM using sodium dithionite (or other reagents) creates a reducing environment for reduction of Cr(VI) to Cr(III). The goal of the ISRM method is to create a permeable treatment zone in the subsurface to

remediate redox-sensitive contaminants. Redox sensitive contaminants in the plume are immobilized or destroyed as they migrate through the manipulated zone. A permeable treatment zone is created by reducing the ferric iron in the aquifer sediments to ferrous iron. The treatment zone is created by injecting appropriate reagents and buffers (e.g., sodium dithionite and potassium carbonate) to chemically reduce the structural iron in the sediments.

Once sodium dithionite was selected as a preferred reagent, a variety of batch and column experiments with sediment and dithionite were performed by Amonette et al. (1994). These bench-scale studies were used to develop an understanding of the important reactions, final reaction products (i.e., residuals), and nature and fate of any ions released from the sediments and sediment surface coatings under reducing conditions (e.g., mobilization of trace metals).

During the summer of 1995, investigators ran a demonstration using ISRM. Pilot-scale experiments tested the feasibility of using ISRM with chemical reagents using a forced gradient, single well, reactive tracer test. Field experiments involved injecting sodium dithionite into an aquifer creating a 60- to 100-ft diameter geochemical PRB ahead of a chromium plume.

Figure 3-7 depicts the ISRM treatment approach (Cummings and Booth, 1997).

This treatment approach could also be classified as a reactive zone technology (see Section 3.3); however, researchers consider it a PRB. After allowing 5 to 30 days for the reaction to occur, water containing the reaction byproducts and any remaining reagent was pumped out. The experiment was designed to evaluate the longevity of the system to maintain a reducing environment (U.S. EPA, 1995b). A buffered sodium dithionite solution (21,000 gallons) was injected into the test site aquifer

over a period of 17.1 hours. A subsequent residence time of 18.5 hours was allowed before sampling and analysis of the groundwater was conducted. No significant plugging of the well screen or aquifer formation was detected during any phase of the test. Sixty to 100 percent of available reactable iron in the aquifer sediments was reduced by the injected dithionite.

Groundwater monitoring 10 months after the injection showed a reducing environment persisting within the redox area. Cr(VI) was reduced and levels remained below the detection limits, and total chromium levels were below 8 mg/L and continued to decline (Cummings and Booth, 1997). Measurements taken after 3 years show that total and Cr(VI) levels were both below the detection limit (<7 ppb), down from 70 ppb initially.

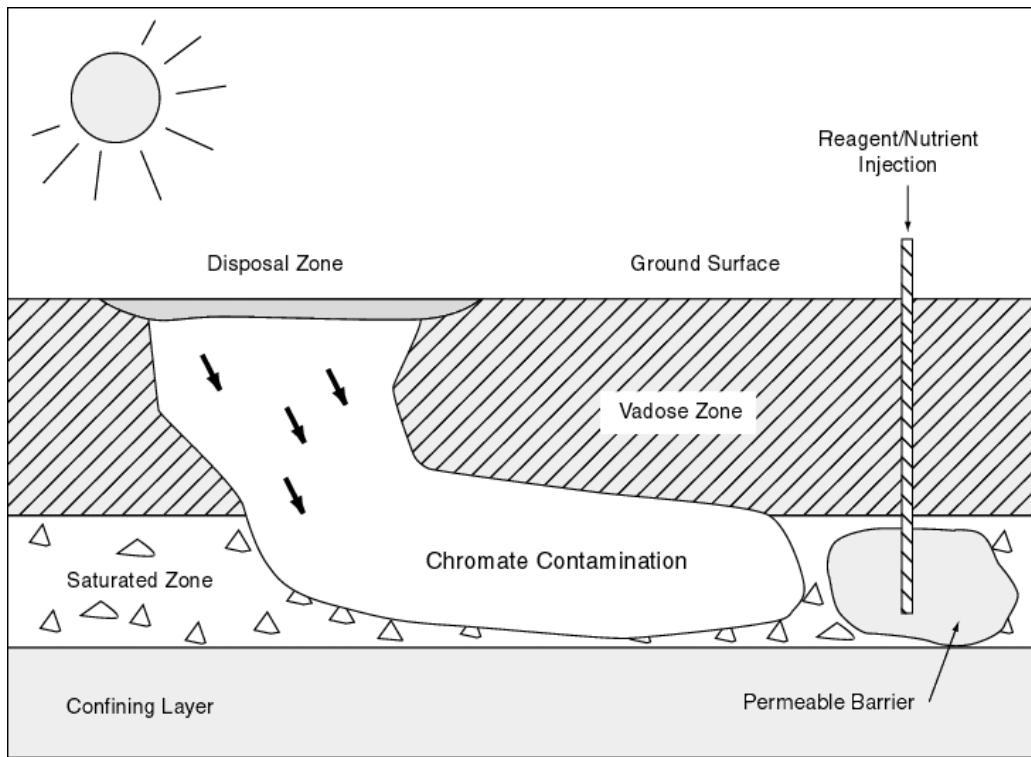

Source: Cummings and Booth, 1997

**Figure 3-7 ISRM treatment system diagram.**

During fiscal year 1998, a five-well, field-scale treatability test was installed at the Hanford 100D Area. The test created a PRB 150 feet long and 50 feet in width. The barrier was placed about 500 feet from the Columbia River in a chromate plume with concentrations in the 1,000 to 2,000 ppb range (as chromium). The depth to groundwater was about 85 ft. An average of about 27,000 gallons of buffered sodium dithionite solution was injected in each of the five wells. The sodium dithionite concentration averaged approximately 0.08M. The average reaction phase was 35 hours.

Recent monitoring data have shown that chromate concentrations in the reduced zone have decreased to below detection limits. In addition, chromate concentrations have begun decreasing in several downgradient monitoring wells. Monitoring is continuing. In addition to monitoring wells near the site, a series of sampling tubes have been placed along the bank of the Columbia River. Sediment cores will be taken in the reduced zone during the summer of 1999 to determine the amount of ferric iron reduced. The results to date are summarized in Williams et al. (1998).

Based on the success of the treatability test, DOE decided to deploy a full-scale barrier at the 100D Area site. Current plans call for the expanded barrier to be approximately 1,000 ft in length. It will be constructed at the same site as the treatability test barrier (Fruchter, 1999).

The ISRM researchers developed a cost comparison between ISRM and traditional pump-and-treat methods. The cost estimates were based on costs from the ISRM field-scale treatability test and from actual implementations of other pump-and-treat

systems and used similar operation and remedial objectives. Under the conditions established at the Hanford site and based on a 10-year project lifetime, ISRM realized an overall estimated cost savings of 62 percent, or \$4.6 million, over traditional pump-and-treat (Cummings and Booth, 1997). The estimated total cost for pump-and-treat was \$8.85 million, and the estimated total cost for ISRM was \$2.95 million. These cost estimates were based on assumptions for costs for equipment procurement, O&M, waste management, system monitoring, and data analysis.

The cost savings accrued by ISRM over the 10-year duration can be attributed mainly to the negligible operating and waste management costs for ISRM. Operating costs for the pump-and-treat system are continuous starting in the second year when the plant is running at full capacity. Waste management costs for ISRM are based on the one-time need to treat and dispose of approximately 1 million gallons of groundwater from the withdrawal of dithionite reagent and reaction byproducts from within the barrier zone. Waste management costs for pump-and-treat are higher because of the greater volume of groundwater that is extracted and treated, and because waste management costs are ongoing for the 10-year lifetime of the project. System design costs are expected to be higher for ISRM than traditional pump-and-treat because of the necessity for thorough characterization of aquifer sediments in addition to groundwater. It should be noted that emplacement of the ISRM permeable barrier and required residence time in the aquifer to initiate conditions for the redox reactions may take several days; the life of the treatment barrier is expected to last for a period of years.



## **Zeolite-Based PRBs**

Two pilot-scale PRB tests were performed with surfactant-modified zeolite (SMZ) material by researchers at the Large Experimental Aquifer Facility of the Oregon Graduate Institute. Natural zeolite material of different mesh sizes was modified with a cationic surfactant to improve its sorptive capacity and hydraulic characteristics. The SMZ was bulk-manufactured at a cost of about \$460 per metric ton (equivalent to \$460/m<sup>3</sup>). The cost of natural zeolite alone is \$45 to \$60 per ton. The SMZ material was placed in a barrier frame in the center of a tank and surrounded by sand to form a simulated aquifer. Chromate-contaminated water was then directed through the reactive barrier (Bowman et al., 1999).

The first test showed that much of the contaminant plume was being deflected under and around the SMZ barrier. This was thought to be due to low SMZ conductivity and a partially plugged barrier frame. It was concluded that care must be taken to eliminate hydraulic restrictions at barrier/aquifer interfaces in order to prevent plume deflection. The SMZ was then replaced with a different mesh size material and the barrier was modified for the second test. No plume deflection occurred in the second test. After 56 days of operation, no downgradient chromate contamination was detected, and low concentrations were detected in the barrier. The estimated pilot test retardation factor for chromate was very close to that predicted from laboratory isotherm experiments. Therefore, it was concluded that laboratory results can be used to predict contaminant retardation using SMZ for a larger scale PRB (Bowman et al., 1999).

Laboratory tests were performed to evaluate the overall efficiency of a combination of SMZ and zero-valent iron (ZVI) for chromate

sorption and destruction. Zeolite/ZVI pellets were first produced and then modified with a cationic surfactant to increase contaminant sorption, and, thus, the contaminant concentration on the solid surface. Chromate sorption/reduction tests with the SMZ/ZVI reactive material were conducted in centrifuge tubes. The mechanical stability of pellets under saturated conditions was also evaluated. Results indicate that the chromate sorption capacity of pelletized SMZ/ZVI was at least one order of magnitude higher than that of zeolite/ZVI pellets. Also, compared to SMZ pellets alone, the chromate removal capacity of SMZ/ZVI in a 24-hour period was about 80 percent higher, due to the combined effects of sorption by SMZ and reduction by ZVI. Therefore, SMZ/ZVI pellets have the potential to lower the amount of reactive material required in a PRB to achieve a target level of contaminant reduction (Zhaohui, 1999).

## **3.3 Reactive Zones**

### **3.3.1 Technology Description**

*In situ* reactive zones are based on the creation of a subsurface zone where migrating contaminants are intercepted and permanently immobilized or degraded into harmless end products. Reactive zones allow groundwater to continue to flow naturally; the groundwater is not funneled or directed into or through subsurface barriers. Groundwater is not extracted; it is a passive treatment system. Reactive zones can be installed slightly downgradient of the source area to prevent mass flux of contaminants from migrating from the source (Nyer and Suthersan, 1996). These treatment zones are usually established *in situ* by injecting reagents and solutions in predetermined locations within the contaminated groundwater plume, and allowing them to “react” with the contaminants. A physical subsurface “barrier” is not used as with PRB technology. Typically, reactive zones

do not directly treat the contaminant source zone, but intercept and treat the contaminant plume; however, source zone treatment may be applicable in some cases such as low permeability formations. Compared to PRBs, reactive zones provide several advantages: no excavation of contaminated soil is needed; the installation and operation are relatively cheaper; human exposure to hazardous materials is minimized; and remediation of deeper contaminated sites can be accomplished (Yin and Allen, 1999).

Successful application of reactive zones requires the ability to engineer two types of *in situ* reactions: (1) between the injected reagents or solutions and the subsurface environment in order to manipulate the biogeochemistry and optimize the required reactions; and (2) between the injected reagents, substrates, or microbes and the migrating contaminants in order to effect remediation. These reactions will differ between sites and even within a site; therefore, the major challenge is to design a reactive zone to systematically control these reactions under naturally variable conditions found in the field (Nyer and Suthersan, 1996). Creation of a spatially fixed reactive zone in an aquifer requires proper mixing of the injected reagents uniformly within the reactive zone. Furthermore, such reagents must cause few side reactions and be relatively nontoxic in both their original and treated forms.

Creation of spatially fixed reactive zones to

achieve these reactions is very cost-effective in comparison to treating the entire plume as a reactive zone (Suthersan, 1997).

The mechanisms that can be used to reduce the toxicity of heavy metals dissolved in groundwater are transformation and immobilization. These mechanisms can be induced by both abiotic and biotic pathways. Abiotic pathways include oxidation, reduction, sorption, and precipitation. Biotically mediated processes include reduction, oxidation, precipitation, biosorption, bioaccumulation, organo-metal complexation, and phytoremediation (Suthersan, 1997). Phytoremediation is discussed separately in Section 3.7 of this Guide.

### ***Design and Application***

*In situ* reactive zones can be designed as a curtain of injection points or multiple curtains to intercept the moving contaminant plume at various locations (see Figure 3-8).

A curtain can be installed slightly downgradient of, or within, the source area to prevent the mass flux of contaminants migrating from the source. This will shrink the size of the contaminant plume faster. If the duration of remediation is a critical factor, another curtain can be installed between the above two curtains for further interception at the middle of the plume (Suthersan, 1997). Contaminated groundwater flows horizontally through the established reactive zones, following the natural hydraulic gradient.

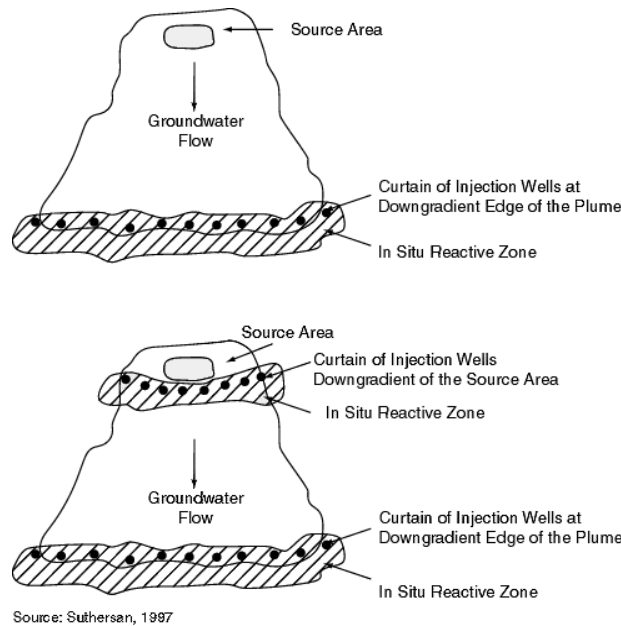

**Figure 3-8 *In Situ* reactive zones curtain design concept (plan view).**

Another approach to designing an *in situ* reactive zone is to create the reactive zone across the entire plume. The injection points can be designed on a grid pattern to achieve the reactions across the entire plume. However, it should be noted that the cost of installation of injection wells constitutes the biggest fraction of the system cost, considering both capital and operational costs. It is clear that the reduction of the total number of injection wells will significantly reduce the system costs. Therefore, the curtain concept is the preferred and most cost-effective approach to implement *in situ* reactive zones (Suthersan, 1997).

An engineered *in situ* reactive zone has to take into consideration how the target reactions will impact the redox conditions within and downgradient of the reactive zone, in addition to degrading the contaminants with the available residence time. In addition, careful evaluation should be performed regarding the selectivity of the injected reagents toward the

target contaminants and the potential to react with other compounds or aquifer materials. Careful monitoring, short-term and long-term, should be performed to determine whether the natural equilibrium conditions can be restored at the end of the remediation process. In some cases, modified biogeochemical equilibrium conditions may have to be maintained over a long period of time to prevent the reoccurrence of contaminants (Suthersan, 1997).

The three major design requirements for implementing an *in situ* reactive zone are: (1) creation and maintenance of optimum redox environment and other biogeochemical parameters such as pH, presence or absence of dissolved oxygen, and temperature, etc.; (2) selection of the target process reactions and the appropriate reagents to be injected to achieve these reactions; and (3) delivery and distribution of the required reagents in a homogeneous manner across the entire reactive zone, both in the lateral and vertical directions (Suthersan, 1997).

### **Site Characterization**

The composition of interstitial water is the most sensitive indicator of the types and the extent of reactions that will take place between contaminants and the injected reagents in the aqueous phase. Determination of the baseline conditions of the appropriate biogeochemical parameters is a key element for the design of an *in situ* reactive zone. This evaluation will give a clear indication of the existing conditions and the necessary steps to be taken to optimize the environment to achieve target reactions. Section 2.3 presents a number of site characterization analytical parameters required for chemical fixation processes. Other biogeochemical parameters that may be needed include:

- Dissolved oxygen
- Temperature
- Total dissolved and suspended solids
- Anions ( $\text{NO}_3^-$ ,  $\text{NO}_2^-$ ,  $\text{SO}_4^{2-}$ ,  $\text{S}^-$ )
- Fe (total and dissolved)
- Alkalinity
- Concentration of dissolved gases ( $\text{CO}_2$ ,  $\text{N}_2$ ,  $\text{CH}_4$ , etc.)

- Microbial population enumeration (total plate count and specific degraders count)
- Any other organic or inorganic parameters that have the potential to interfere with the target reactions.

It should be noted that the number of parameters that need to be included in the list of baseline measurements will be site-specific and will be heavily influenced by the target reactions to be implemented within the reactive zone (Suthersan, 1997).

Design of a reagent injection system entails an extensive evaluation and understanding of the hydrogeologic conditions at the site and specifically within the plume and the location of the reactive zones. Table 3-4 lists specific geologic/hydrogeologic parameters required for the design of an *in situ* reactive zone. Delivery, distribution, and proper mixing of the injected reagents are key elements to the success of remediation within an *in situ* reactive zone. Location and spacing of the injection wells and the placement of screens within each well (cluster) are critical to achieve complete remediation.

**Table 3-4. Impacts of Various Geologic/Hydrogeologic Parameters on the Design of an *In Situ* Reactive Zone.**

<b>Geologic/Hydrogeologic Parameter</b>	
Depth to water table	Injection well depth and screen locations.
Width of contaminant plume	Number of injection wells.
Depth of contaminant plume	Number of injection points within a well cluster. Pressure injection vs. gravity feed.
Groundwater velocity	Injection flow rate, residences time for the target reactions. Dilution of end products.
Hydraulic conductivity (horizontal and vertical)	Mixing zones of reagents, extent of reactive zone. Number of injection points within a well cluster.
Geologic variations, layering of various soil sediments	Location of well screens within injection points.
Soil porosity and grain size distribution	Removal of end products resulting from immobilization reactions (such as heavy metals precipitation).

***Injection of Reagents and Solutions***

Injection of reagents and other solutions can be implemented in two ways: (1) gravity feed, and (2) pressure injection deeper into the well. Figures 3-9 and 3-10 depict these two approaches. Gravity feed is possible only when the depth of contamination is very shallow. Under gravity feed conditions, injected reagents will tend to spread over the water table as a sheet flow, and the mixing within the reactive zone will be dominated by diffusion, rather than advective flow.

When the depth of contamination is deeper, multiple injection points may be required within a well cluster at each injection point. The reagent solution will have to be injected under pressure into the injection well. Under this configuration, mixing within the reactive zone will be influenced by both advective and diffusional transport of the reagents. The concentration of the injected feed solution should be dilute enough to avoid any downward migration due to density differences between the reagent and groundwater (Suthersan, 1997).

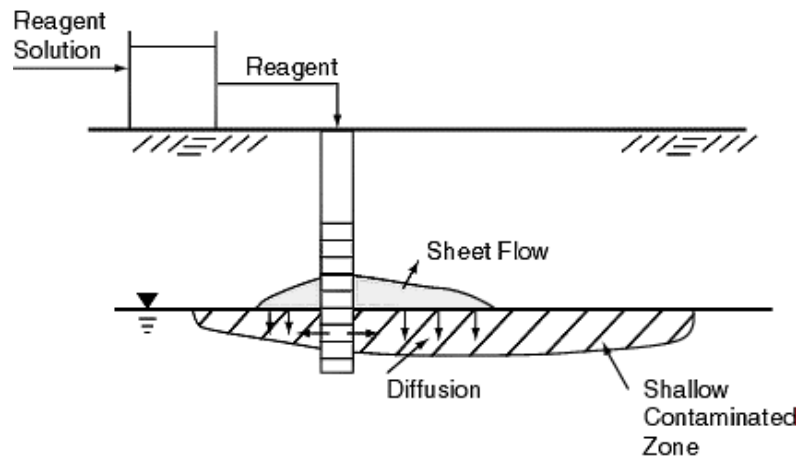

Source: Suthersan, 1997

**Figure 3-9. Gravity feed of reagents when the contamination is shallow.**

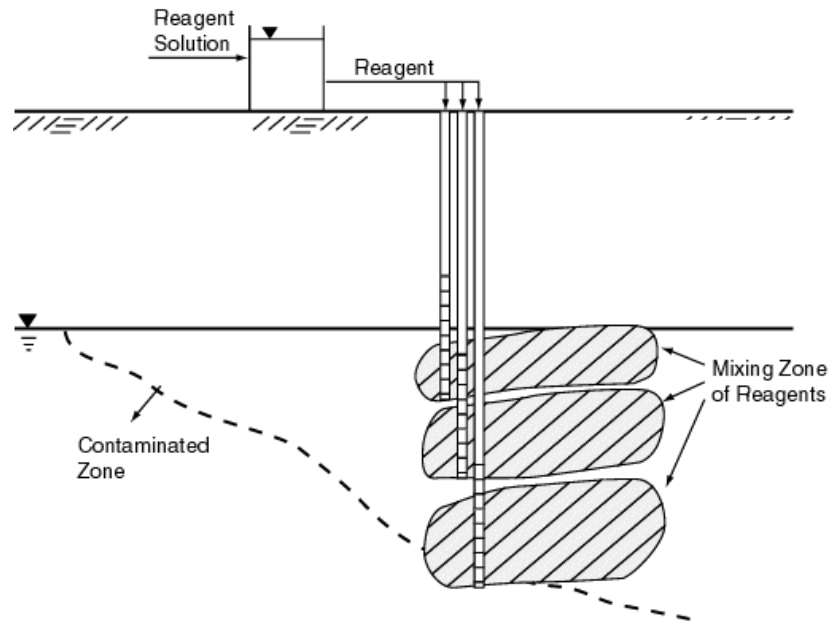

Source: Suthersan, 1997

**Figure 3-10. Multiple cluster injection points when contamination is deep.**

During gravity feed of the reagents, the lateral spread of the injected solution will be significant due to the sheet flow effect. However, under pressure injection conditions,

downgradient migration of the injected reagents and, thus the mixing zone could be very narrow, depending on the hydrogeologic conditions within the reactive zone. One way to

overcome this problem is to install closely spaced injection points. This option, even though it is easier to implement, will significantly increase the cost of the system. Cyclic extraction and injection of adjoining wells, treated as a pair, will create a wider mixing zone downgradient of the injection wells and will eliminate the need to install closely spaced injection points. Extracted groundwater can be used as the dilution water to maintain the feed injection solution concentration (Suthersan, 1997).

### **Reagent-Based Reactive Zones**

Dissolved Cr(VI) can be reduced and precipitated as chromic hydroxide [Cr(OH)<sub>3</sub>] by the injection of ferrous sulfate solution into the reactive zone at appropriate concentrations. Reduction and precipitation in reactive zones can also be accomplished using other chemical reductants (refer to Section 3.1 on Geochemical Fixation). Cr(VI) exists as chromate under neutral or alkaline conditions and dichromate under acidic conditions. Both species react with ferrous ion to become Cr(III) and Fe(III). Both Cr(III) and Fe(III) ions are highly insoluble under natural conditions of groundwater. The addition of ferrous sulfate into the reactive zone may create acidic conditions, and hence the zone downgradient of the ferrous sulfate injection zone may have to be injected with soda ash or caustic soda to bring the pH back to neutral conditions (Suthersan, 1997). Fe<sup>0</sup>, commonly used with PRBs, can also be injected into the path of a contaminated plume to effect chromate reduction and precipitation.

### **Molasses-Based Reactive Zones**

Injection of a carbohydrate solution such as diluted molasses can promote the *in situ* microbial reduction of Cr(VI) to Cr(III) (Suthersan, 1997). The carbohydrates, which consist mostly of sucrose, are readily degraded by the heterotrophic microorganisms present in the aquifer, thus depleting all the available dissolved oxygen present and causing reducing conditions to develop. The primary end product of the Cr(VI) to Cr(III) reduction

process is Cr(OH)<sub>3</sub>, a form of Cr(III), which readily precipitates out of solution under alkaline to moderately acidic conditions. Cr(OH)<sub>3</sub> precipitate is essentially an insoluble, stable precipitate, immobilized in the soil matrix of the aquifer (Nyer and Suthersan, 1996).

### **Other Biotic Reactive Zones**

*Unicellular Yeast:* Chromium can be removed from groundwater by the unicellular yeast, *Saccaromyces cerevisiae*. Several species of bacteria, yeast, and algae are capable of accumulating metal ions extracellularly or internally to concentrations several orders of magnitude higher than the background concentration, and many bacteria reduce Cr(VI) to Cr(III). Of the microorganisms studied, *S. cerevisiae* was the only one that did not result in an unpleasant or dangerous side effect such as an unpleasant odor created in the water or pathogenic results (Krauter et al., 1996).

Microorganisms respond to metals by several processes, including transport, biosorption to cell biomass, entrapment in extracellular capsules, precipitation, and oxidation-reduction reactions. Bioaccumulation of metal cations has been demonstrated by two processes: an initial rapid accumulation that is independent of metabolism and temperature, and a metabolically mediated process that internalizes the cation into the cell. Energy-dependent uptake of divalent cations by *S. cerevisiae* is well known, with influx being dependent on the electrochemical proton gradient across the plasma membrane (Krauter et al., 1996).

*Dissimilatory Metal-Reducing Bacteria:* Reduction of heavy metals, such as chromium, through dissimilatory metal-reducing bacteria (DMRB) has also been examined. DMRB gain energy to support anaerobic growth by coupling the oxidation of H<sub>2</sub> or organic matter to the reduction of a variety of multivalent metals. This metabolism can lead to the complete mineralization of organic matter or to the precipitation and immobilization of metal contaminants under anaerobic conditions. *In*

*situ* bioremediation strategies using DMRB would rely on either stimulating naturally occurring DMRB populations or inoculating preadapted or genetically engineered DMRB into contaminated environments.

One difficulty of adding DMRB to a contaminated area is that often vegetative bacteria tend to bind to the substratum and are rarely found far downstream from injection wells. Starvation techniques have been developed as a means of preparing bacteria for *in situ* bioremediation. In order to survive the oligotrophic conditions of certain natural environments, many non-spore-forming bacteria exhibit a starvation-survival response under which cell size and susceptibility to harsh conditions are reduced drastically. Although these cells are metabolically dormant, they are resuscitated to their vegetative state when exposed to nutrients (Caccavo et al., 1996).

**Biom mineralization:** Biom mineralization is the microbially mediated genesis of new mineral species. Specific microbial strains can be employed to form geologically stable minerals on solid substrates such as soils, fractures, and ores. The microbial systems can be engineered to form specific biom minerals which can incorporate and immobilize metal contaminants (SAIC, 1998).

Biom mineralization processes are part of a natural cycle in which minerals are continuously formed, transformed, and degraded. *In situ* biom mineralization capitalizes on the role that microorganisms play in natural ore formation and involves accelerating the biological reactions to remediate waste. Researchers have evaluated the use of bioremediation processes for *in situ* biom mineralization of heavy metals in mine wastes. During biom mineralization, microorganisms initiate a complex series of reactions. Effective metal removal mechanisms are influenced by biologically catalyzed remineralization reactions (Pintail Systems, 1998).

Biom minerals are geologically stable compounds

that chemically bind the contaminants; other polymeric and adsorption techniques do not provide the same chemical stability. Biom minerals can be designed to be selective for specific contaminants. Bioremediation fluids can infiltrate pore spaces and micro fractures, as opposed to cementitious compounds.

The biom mineralization process can potentially be applied to the subsurface treatment of mobile metals by the formation of an *in situ* biom mineral barrier. The barrier is formed by injecting bacterial and nutrient solutions into the aquifer materials through a series of inoculation (injection) wells. The biom mineral barrier functions as a reactive zone to specific metal contaminants. The metal(s) are incorporated into, and stabilized by, the resultant biom mineral product. The subsurface barrier formation can be enhanced through controlled hydro-fracturing.

### **Advantages**

- Eliminates the infrastructure required for a pump-and-treat system; no disposal of water or waste.
- Inexpensive installation; primary capital expenditure for this technology is the installation of injection wells.
- Inexpensive operation; reagents are injected at fairly low concentrations and the only sampling required is groundwater monitoring.
- Can be used to remediate deep site; no physical limits as with treatment walls.
- Unobtrusive; once the system is installed, site operations can continue without any obstructions.
- Less expensive than most remediation technologies.
- Immobilization of contaminant; uses the capacity of the soils and sediments to absorb, filter, and retain contaminants.



- All biotic processes used for remediation use simple sugars and bacteria natural to the aquifer, therefore, it is completely natural.
- DMRB starvation reduces cell size and facilitates transport of bacteria through substratum to the contaminated zone.
- Tools to predict/estimate and measure the target reaction kinetics in an *in situ* environment.
- Tools to quantify reagent and pore water chemistry at the field scale.
- Reactive transport modeling tools to couple the microbial and chemical reactions to the physical transport processes.

### Limitations

- Longer time required for remediation treatment.
- The metal is not actually removed from the water, it is only put into a state in which the water carrier will no longer interact with it.
- Results in limited hydraulic control.
- Potential for short-circuiting or incomplete treatment; barrier integrity verification is more difficult.
- May not remove source of contamination; mitigates contaminant plume.
- Low permeability sites may preclude use of this method, but may be applicable to source zone treatment.

- Better methods to measure the intra-aqueous redox and biogeochemical kinetics.
- Better understanding of the long-term fate of the immobilized contaminants.

Laboratory and field testing has been conducted with some of the biotic reactive zone processes. These studies are described in section 3.3.3.

### 3.3.3 Performance and Cost Data

#### ***Molasses-Based Reactive Zone***

*Site 1:* A field pilot-scale demonstration test was performed by investigators at an industrial facility in the Midwestern United States to evaluate this reactive zone remediation technique involving the *in situ* reduction of chromium. As of 1997, this evaluation involved conducting a 6-month *in situ* test near the source area at the site to determine the degree to which Cr(VI) could be reduced and precipitated out within the aquifer due to the development of biologically induced reducing conditions. The test was developed to evaluate this innovative *in situ* remediation technique that could potentially be used to augment or replace the conventional pump-and-treat system which was previously operated at the facility. The field test required the installation of three injection wells and five monitoring wells. These wells added to the existing monitoring well network at the facility.

### 3.3.2 Status

The *in situ* reactive zone approach is an innovative and developing technology in the remediation industry. Implementation and wide acceptance of this technology is still in its infancy, and thus the experience, knowledge, and performance and cost data for this technology is very much empirically based (Suthersan, 1997). A substantial amount of developmental work needs to be done on this new technology before it reaches wide regulatory acceptance. Future work should focus on:

- Tools to design the appropriate specification of injection rates, durations, and concentrations to achieve optimal control at the field scale.

To promote the *in situ* biological reduction of Cr(VI) to Cr(III), a dilute water/blackstrap molasses solution (200:1 dilution, by volume), which contains readily degradable carbohydrates and sulfur, was injected via three injection wells (at a batch feed rate of approximately 40 gallons every 2 weeks per injection well) into the shallow portion of the impacted aquifer. The installed injection and monitoring wells were shallow wells screened across a 1- to 3-ft thick sand seam at an approximate interval of 10 to 15 ft below grade (Suthersan, 1997).

Because of the rapid inducement of reducing conditions, the concentration of Cr(VI) in the injection wells decreased from a high of 15 mg/L to below 0.2 mg/L during the first month of process operation. The levels of Cr(VI) measured in the injection wells remained below the cleanup objective of 0.2 mg/L through the first 6 months of monitoring. The laboratory analytical results for Cr(VI) measured in the injection well samples collected 3 months following process initiation were all below the detection level of 0.05 mg/L, according to investigators. In these same samples, the levels of total chromium were slightly higher than the levels of Cr(VI) but were still below the 0.2 mg/L groundwater cleanup objective for this site. This indicates that chromium remaining in the groundwater was in the trivalent form, rather than in the more toxic and mobile Cr(VI) form. In addition, it is important to note that the analytical data were based on unfiltered groundwater samples.

Because only trace amounts of Cr(III) had been detected in the unfiltered groundwater samples, it appears that the chromium precipitates were being retained by the aquifer materials and were not subject to colloidal transport through the aquifer (Suthersan, 1997).

*Site 2:* A full-scale application of the molasses-based reactive zone was conducted at a site in central Pennsylvania. Groundwater was impacted by Cr(VI) downgradient of an operating manufacturing facility. This site was placed on the NPL list in 1988 and a ROD was issued in 1991 by EPA. Following a successful pilot-study demonstration, a full-scale remediation system was installed to develop and maintain an anaerobic environment capable of reducing and precipitating Cr(VI). Figure 3-11 shows the molasses injection system that was installed at the facility and that went on line in January 1997. The system utilized 20 installed injection wells and 16 existing municipal wells to establish reactive zones. Ten gallons of solution per well were injected twice a day. The mixing ratio for molasses was varied from 1:200 to 1:20. A programmable logic controller (PLC) monitored and controlled the feedrate and frequency of the molasses feed and solution feed pumps, as well as the timing of the solenoid valve network that controlled the metered flow to the injection wells. Monthly to quarterly sampling has been conducted for pH, redox levels, and chromium concentrations (Burdick and Jacobs, 1998).

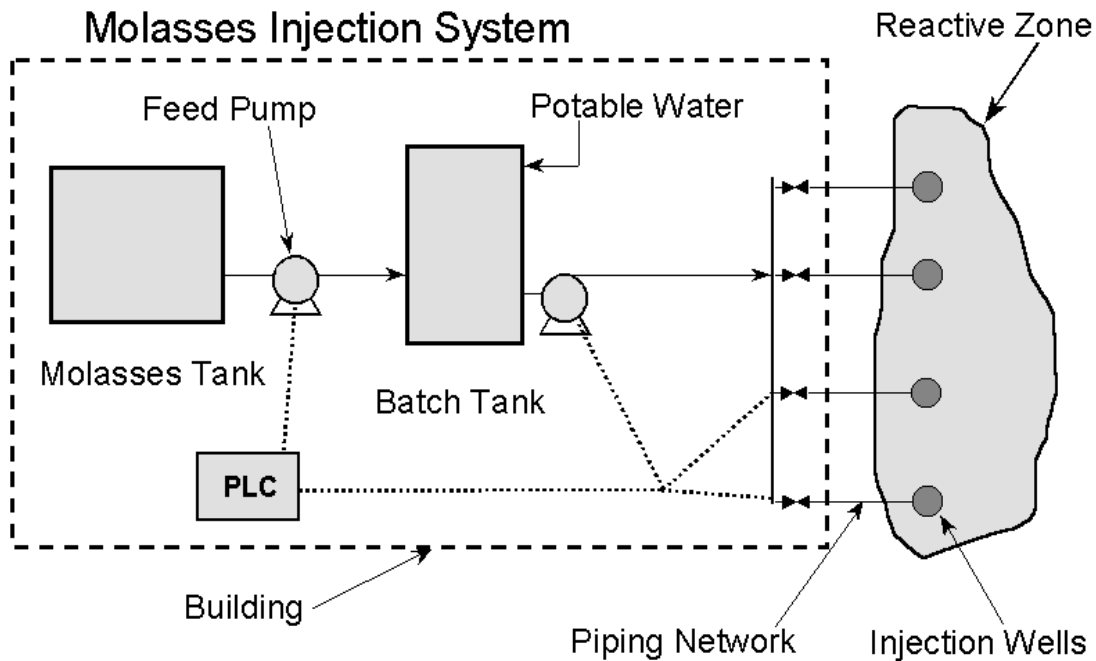

Source: Lenzo, 1999

**Figure 3-11. Schematic of molasses-based injection system used at central Pennsylvania site.**

The injection of the molasses-based reagent was successful in creating a anaerobic groundwater environment and has resulted in Cr(VI) concentrations being decreased significantly. Figures 3-12 and 3-13 show how the extent and concentrations of Cr(VI) groundwater plume were reduced in a year and a half. The overall chromium plume shrunk to approximately one-fourth its original area. The concentration of Cr(VI) was reduced from 1.95 mg/L to 0.01 mg/L in the southern portion of the treatment area. The peak chromium concentrations are isolated to one area at slightly above 0.5 mg/L, as shown in Figure 3-13.

After close to 3 years of operation, chromium concentrations were reduced to below the regulatory target across the entire site, according to investigators (Lenzo, 1999).

The cost to implement the molasses-based reactive zone technology and operate it for a little less than 3 years was approximately \$400,000 including capital, O&M, and monitoring. This system replaced a pump-and-treat system that had an estimated present worth of over \$4,000,000. This figure included capital costs and O&M for a period of 20 years (Lenzo, 1999).

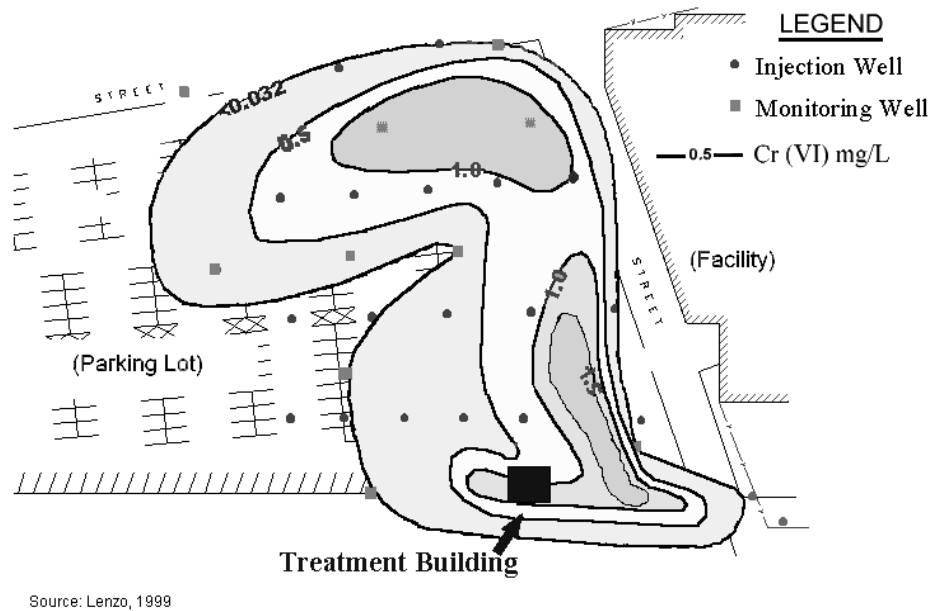

**Figure 3-12. Plot of hexavalent chromium contaminant plume at central Pennsylvania site - January 1997.**

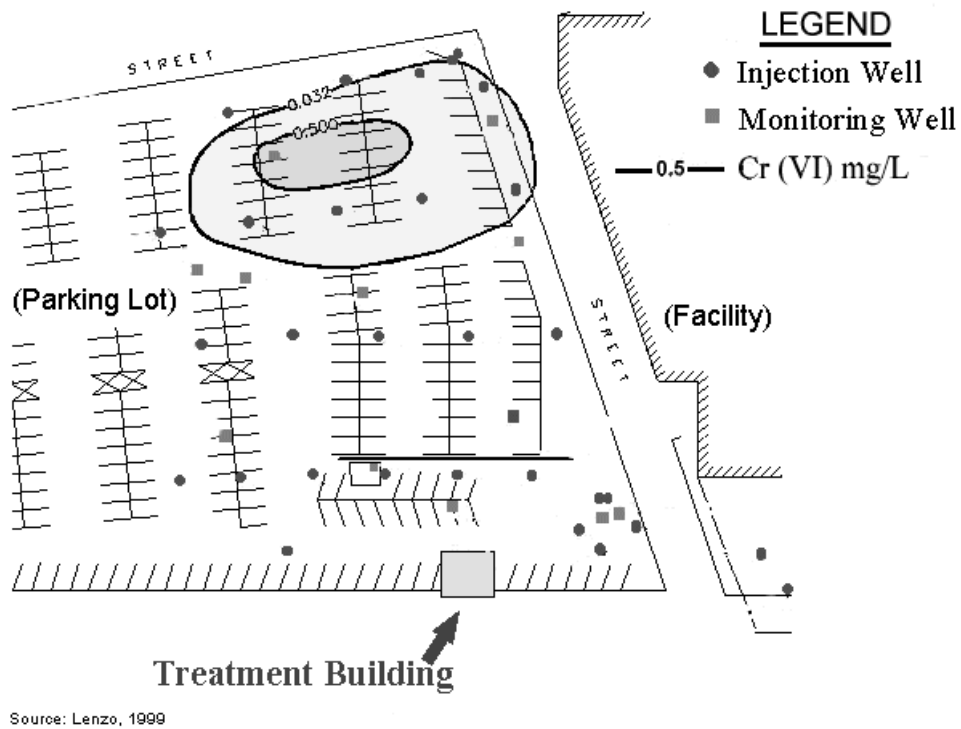

**Figure 3-13. Plot of hexavalent chromium contaminant plume at central Pennsylvania site - July 1998.**

### **Other Biotic-Based Reactive Zones**

**Unicellular Yeast:** Laboratory studies were performed using amended groundwater to investigate the use of the yeast *S. cerevisiae* as an agent to remove Cr(VI). These studies also examined the effects of pH, temperature, and energy source concentration on Cr(VI) removal. Results of these studies showed *S. cerevisiae* removed Cr(VI) at the moderate rate of 0.227 mg/h (g dry wt biomass)<sup>-1</sup> (Krauter et al., 1996).

**DMRB:** Experiments were conducted examining the effects of starvation on a model DMRB, *Shewanella alga* BrY. *Shewanella alga* bacteria were shown to reduce Fe(III) to Fe(II), which in turn reduces Cr(VI). By starving the *S. alga* BrY, thereby reducing its cell size and endogenous metabolic activity, and resuscitating it with a variety of electron acceptors, including oxygen, Fe(III) and natural subsurface materials, the DMRB can be delivered into a reactive zone contaminated with chromium in a faster, more effective manner (Caccavo, 1996). Studies have shown that starved *S. alga* BrY can reduce 90 percent of Fe(III) in subsurface material to Fe(II) within 4 days (Caccavo, 1996).

**Biomineralization:** Work to date with biomineralization has focused on the treatment of metal bearing ores and mine process solutions. Treatment strategies have been applied both *in situ* as well as *ex situ*. This technology was accepted into the EPA Emerging Technology Program in 1995 for evaluation. Further development of the process could result in a field-ready *in situ* biomineralization technology. However, biomineralization is still an emerging technology, and is not yet proven for *in situ* applications. Investigators have demonstrated biomineralization of metals in laboratory and pilot-scale tests for mining industry clients at mines in the U.S. (Idaho, Nevada, Arizona,

California, Colorado), Mexico, and Canada. Performance and cost data for *in situ* metals treatment using the biomineralization process were not available during preparation of this Guide.

## **3.4 Soil Flushing/Chromium Extraction**

### **3.4.1 Technology Description**

*In situ* soil flushing is used to mobilize metals by leaching contaminants from soils so that they can be extracted without excavating the contaminated materials. Water or an aqueous solution is injected into or applied onto the area of contamination to mobilize the contaminants. The flushing solution can be applied by surface flooding, sprinklers, leach fields, vertical or horizontal injection wells, basin infiltration systems, or trench infiltration systems. After contact with the contaminated material, the flushing solution is collected using pump-and-treat methods for disposal or treatment and reuse.

*In situ* soil flushing can enhance conventional pump-and-treat by providing a hydraulic push in an aquifer, by increasing the hydraulic gradient, and by solubilizing/mobilizing metal contaminants more rapidly. This can result in an accelerated rate of contaminant removal (Steimle, 1997).

Metal contaminants are mobilized *in situ* by solubilization, formation of emulsions, or a chemical reaction with the flushing solution. Various water treatment techniques can be applied to remove the extracted metals and to recover the extraction fluid (if other than water) for reuse. The separation of surfactants from recovered flushing fluid for reuse in the process is a major factor in the cost of soil flushing. Treatment of flushing fluid results in process sludges and residual solids. Residual flushing additives in the soil may be a concern and should be evaluated on a site-specific basis. Figure 3-14 shows a generalized schematic of the *in situ* flushing process.

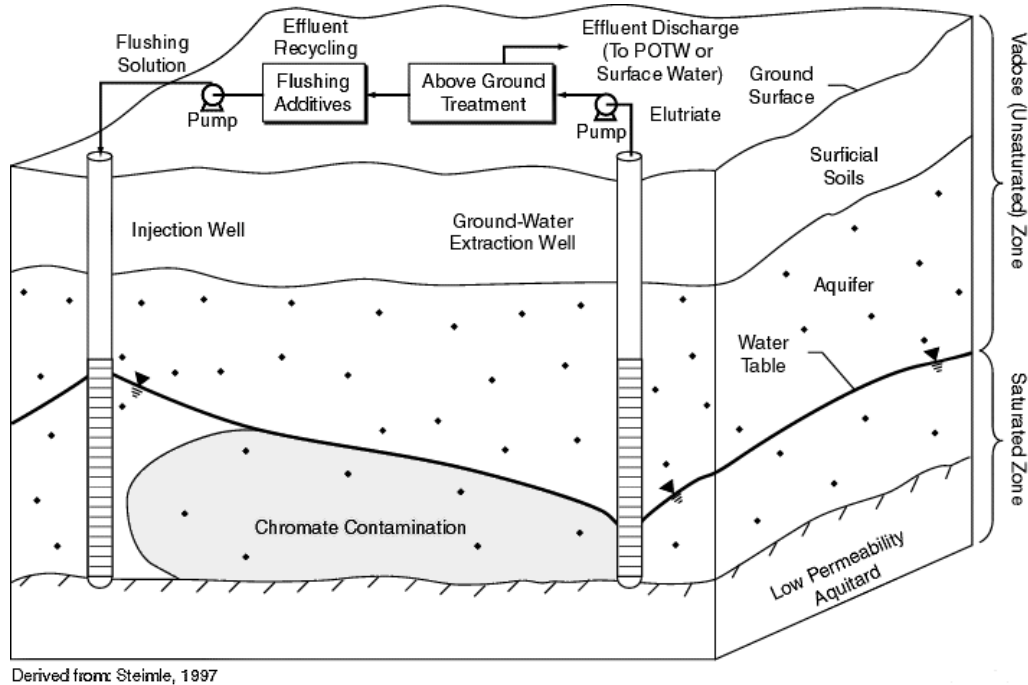

**Figure 3-14. Schematic of *in situ* flushing system.**

Subsurface containment barriers (e.g., a slurry wall) can be used in conjunction with soil flushing technology to help control the flow of flushing fluids. Soil flushing is most applicable to contaminants that are relatively soluble in the extracting solution, and that will not tend to sorb onto soil as the metal-laden flushing fluid proceeds through the soil to the extraction point. The selected flushing fluid must be compatible with the metal(s) of concern and the soil properties to work effectively. Optimal conditions for extraction of Cr(VI) using soil flushing are permeable soil with low iron oxide, low clay, and high pH. Flushing enhancements that are currently being researched include acids, bases, chelating agents, and surfactants/cosolvents to aid in the desorption/dissolution of the target metals (U.S. EPA, 1997). The use of chelating

additives for treating metals *in situ* has not yet been found to be effective (USEPA, 1996).

Surfactant-enhanced extraction can be used to expedite the removal of chromium from source zone soils in order to mitigate the continual leaching of the contaminant into the groundwater plume. Lately, surfactant-enhanced pump-and-treat remediation has received considerable attention. Surfactants have an amphiphilic structure that results in their surface active nature, and causes them to concentrate in interfacial regions (Sabatini et al., 1997). A surfactant adsorbs to interfaces and significantly decreases the interfacial tension and alters the wetting properties of the soil matrix (Palmer and Fish, 1992). It is hypothesized that surfactants can displace adsorbed chromate by either ion exchange, precipitation-dissolution, and/or counterion

binding mechanisms, and that further enhancement in extraction may be achieved if surfactants with solubilized complexing agents are used (Sabatini et al., 1997). In effect, the use of surfactants helps to overcome mass transfer limitations for contaminant removal.

Soil flushing can be applied to source zone soils if additives are used to accelerate treatment. Soil flushing with water alone can be applied to the concentrated or dilute portions of the groundwater plume, depending on how easily the metals contamination can be mobilized.

The applicability of *in situ* soil flushing technologies to contaminated sites will depend largely on site-specific properties, such as hydraulic conductivity, that influence the ability to contact the contaminants with the extractant and to effectively recover the flushing solution with collection wells (Evanko and Dzombak, 1997).

Some factors that are critical for the success of soil washing for chromium and metals extraction include hydraulic conductivity, cation exchange capacity (CEC), clay content, and carbon content. Sites with higher hydraulic conductivity are more conducive to effective soil flushing. Higher levels of CEC, clay content, and organic carbon increase sorption and inhibit metals contaminant removal.

Aboveground sprayers, infiltration galleries, and injection/extraction wells can be used to accomplish flushing of soil and groundwater. Some equipment can be mobile. Tanks or ponds are needed for washwater preparation and wastewater treatment. Slurry walls or other containment structures may be needed along with hydraulic controls to ensure capture of contaminants and flushing additives. Cold weather freezing must be considered for shallow infiltration galleries, aboveground sprayers, and extracted wastewater treatment. Permits may be required for operation, air discharges, and injection of flushing additives, depending on the system being utilized and the contaminants of concern (U.S. EPA, 1997).

## Advantages

- Can potentially accelerate removal of chromium in source areas and meet clean-up goals.
- Removal of chromium source contamination will beneficially impact down gradient groundwater plume.
- Contaminant is removed from the soil or aquifer material and may be applicable to recovery.
- Eliminates the need to excavate, handle, and dispose of large quantities of contaminated soil.
- Can reuse some flushing solutions after treatment for separation, providing cost savings.
- Equipment used for the technology is relatively easy to construct and operate.
- Useful in treatment train applications.

## Limitations

- May be more applicable to organic contaminants than metals.
- Still in the developing stage; limited field experience.
- Not considered Resource Conservation and Recovery Act (RCRA) Best Demonstrated Available Technology (BDAT) for chromium, lead, mercury, arsenic, and cadmium.
- May not be applicable for certain site characteristics such as low hydraulic conductivity and high organic matter content.
- May be difficult to apply to sites contaminated with more than one type of metal.

- Treatment time may be very long unless additives are used for enhanced treatment.
- Surfactant solutions may leave residual surfactant in aquifer materials.
- Has a potential for spreading contaminants horizontally or vertically.
- It may be difficult to gain regulatory approval for injection of surfactant solutions due to concerns over residuals and toxicity.

### 3.4.2 Status

In the U.S., where full-scale site remedies have utilized *in situ* flushing, water is typically used as the flushing solution. This technology has been applied for a limited number of metal-contaminated sites; it is still in a developing stage. There has been more research and application of the technology for organic forms of contamination. At least two applications of soil flushing with water for chromium removal have been documented: the United Chrome Products Superfund site in Corvallis, Oregon, and the Lipari Landfill site in New Jersey. Remediation at the United Chrome site began in 1985 and has used infiltration basins and trenches to flush contaminated soils, a 23-well groundwater extraction network, on-site treatment of wastewater, and off-site disposal of contaminated soil and debris (Evanko and Dzombak, 1997; USEPA, 1997).

Sabatini et al. (1997) and Nivas et al. (1996) showed the ability of surfactants to enhance the elution of chromate in column studies significantly. Their laboratory batch and column studies also evaluated hypotheses concerning the displacement of adsorbed chromium by surfactants and complexing agents. Their work showed that while this technology has great promise for enhancing chromium extraction from soils, further laboratory and field-scale studies are necessary to evaluate operational considerations prior to full-scale implementation. This work was conducted

using chromium-contaminated soil samples from the USCG Support Center site in Elizabeth City, North Carolina.

Researchers are also investigating the effects of numerous soil factors on heavy metal sorption and migration in the subsurface. Such factors include pH, soil type, soil horizon, CEC, particle size, permeability, specific metal type and concentration, and type and concentrations of organic and inorganic compounds in solutions (U.S. EPA, 1997). Major concerns for *in situ* flushing are the uncertainty of the fate and effects of washing reagents in the subsurface environment, and preventing mobilized contaminants from migrating into the surrounding environment (Yin and Allen, 1999).

### 3.4.3 Performance and Cost Data

#### **United Chrome Products Superfund Site**

At the United Chrome Products site, soil and groundwater were heavily contaminated with chromium, having total chromium levels in the soil as high as 60,000 mg/kg and levels in the groundwater reaching up to 19,000 mg/L. The *in situ* flushing procedure used at this site leached contaminants from the unsaturated and saturated zones, and provided for recharge of the groundwater to the extraction wells. According to investigators, this cleanup operation removed significant amounts of chromium from the soil and groundwater, and the pumping strategy achieved hydraulic containment of the plume. Cr(VI) levels in extracted groundwater decreased from a maximum measured concentration of more than 5,000 mg/L to approximately 50 mg/L during the first 2.5 years of operation using water flushing. The average chromium concentration from multiple measurements in the groundwater plume decreased from 1,923 mg/L to 207 mg/L after flushing the first 1.5 pore volumes (approximately 2.6 million gallons for one pore volume). This removal rate was expected to continue for the first few pore volumes of treatment until Cr(VI) removal began to tail off to the asymptotic level (Sturges et al., 1992).



### **Elizabeth City, North Carolina USCG Site**

Batch and column extraction studies using surfactants were performed on chromium-contaminated source zone soils from the Elizabeth City, North Carolina USCG site. These studies were designed to evaluate the efficiency of chromate extractions for selected surfactants and complexing agents, and to evaluate the mechanisms of removal. In the batch studies, the amount of Cr(VI) removed was observed to increase with anionic surfactant concentration. At concentrations greater than the critical micelle concentration (CMC), where micelles or droplets form, Cr(VI) removal was relatively constant.

enhanced the extraction of Cr(VI) by an order of magnitude greater than that obtained with DI water.

The column study results supported the batch study results. As seen in Table 3-6, the ratio of Cr(VI) removed by surfactant (with or without the solubilizing complexing agent, diphenyl carbazide (DPC)) was greater than for DI water only, and the number of pore volume flushes required was less with the surfactants. These studies demonstrated that surfactant-enhanced systems have the potential to enhance chromium extraction by a factor of 2 to 3 versus water alone, and surfactant with complexing agent systems can enhance

**Table 3-5. Results of Cr(VI) Extraction Studies by Surfactants and Hydrotropes from Elizabeth City Soil.**

Extracting Agent	Extracting Agent Conc. at Max. Cr(VI) Removal, mM	Ratio to CMC	Max. Cr(VI) Conc., ppm	Ratio of Cr(VI) Removal by Extracting Agent to That by Water
D.I. Water	—	—	2.6	1
AOT	3	2.7	5.2	2.0
SDS	10	1.2	6.4	2.5
Dowfax 8390	1	0.3	5.6	2.1
Deriphath-160	5	—	7.4	2.8

Source: Sabatini et al., 1997

The ratio of maximum Cr(VI) removal by surfactants to that of deionized (DI) water ranged from 2.1 for the surfactant Dowfax 8390, to 2.8 for the surfactant Deriphath-160 (see Table 3-5). It was postulated, based on test results, that ion exchange was the primary extraction mechanism. Tests were also conducted to see if solubilizing complexing agents would enhance Cr(VI) extraction. In all cases, the surfactant with solubilized complexing agent additive outperformed the surfactant only results; the addition of a chromium (solubilizing) complexing agent

chromium extraction by an order of magnitude greater versus water alone systems. The researchers also concluded that operational considerations for surfactant extraction of chromium require additional research. For example, it was suggested that the removal of Cr(VI) from the soil can be further enhanced by optimizing the time of switching from injection of surfactant with DPC to surfactant alone and/or by increasing the surfactant concentration. Laboratory and field studies are critical prior to full-scale implementation (Sabatini et al., 1997).

**Table 3-6. Cr(VI) Extraction From Columns by Water, Surfactants Alone, and Surfactant Solubilized DPC**

Extracting Agent	Max. Cr(VI) Removed in Effluent, ppm	Ratio of Cr(VI) Removed by Extracting Agent to that by D.I. Water	
DI Water	5.3	1	35.9
AOT	7.0	1.3	26.5
Dowfax 8390	11.8	2.2	24.4
AOT with DPC	10.3	1.9	24.3
Dowfax with DPC	19.7	3.7	18.9

Source: Sabatini et al., 1997

Cost data for chromium or metals-specific site remediations using *in situ* soil flushing/extraction were not available during preparation of this Guide. However, cost estimates for use of the technology on a variety of contaminants have been compiled from EPA documents. One source provides an estimated cost range for soil flushing of \$60 to 163/ton (U.S. EPA, 1997). These cost estimates generally do not include pretreatment, site preparation, regulatory compliance costs, costs for additional treatment of process residuals, or profit. The actual cost of employing soil flushing technology at a specific site may be significantly different than these estimates.

Another source estimates the operating costs for soil flushing/extraction technology at approximately \$70 to 170/ton (Evanko and Dzombak, 1997). The initial and target contaminant concentrations, soil permeability, and the depth of the aquifer will influence costs. Chemically enhanced (surfactants, etc.) flushing systems will have additional costs associated with reagents and equipment needed to handle the flushing solution.

### 3.5 Electrokinetics

#### 3.5.1 Technology Description

The theory of applying electric current to groundwater for remediation of heavy metal and other wastes is called electrokinetic

remediation. It is also called electroreclamation and electrochemical decontamination. Electrokinetics is a process that separates and extracts heavy metals, radionuclides, and organic contaminants from saturated or unsaturated soils, sludges, and sediments.

Basically, a series of electrodes are placed in a contaminated area to which a low voltage (50 to 150 volts) direct charge is then applied. Because of the charge on water and the contaminant, desorption and subsurface migration will occur towards the oppositely charged electrodes. Active electrodes in water cause an acid front at the anode and a base front at the cathode. The pH will drop at the anode and increase at the cathode. To prevent this pH imbalance, the electrodes are placed inside ceramic casings which are filled with a processing fluid. This processing fluid not only keeps a balance of pH at the anode and the cathode, it can also help solubilize and move contaminants. Electrokinetic treatment concentrates contaminants in the solution around the electrodes. Contaminants can be removed from this solution by electroplating or precipitation/coprecipitation at the electrodes, or by pumping the contaminant and processing fluid to the surface and treating with ion exchange resins other methods to recover the extracted metal and reuse the processing fluid in the electrokinetic system. Figure 3-15 is a schematic of the process.

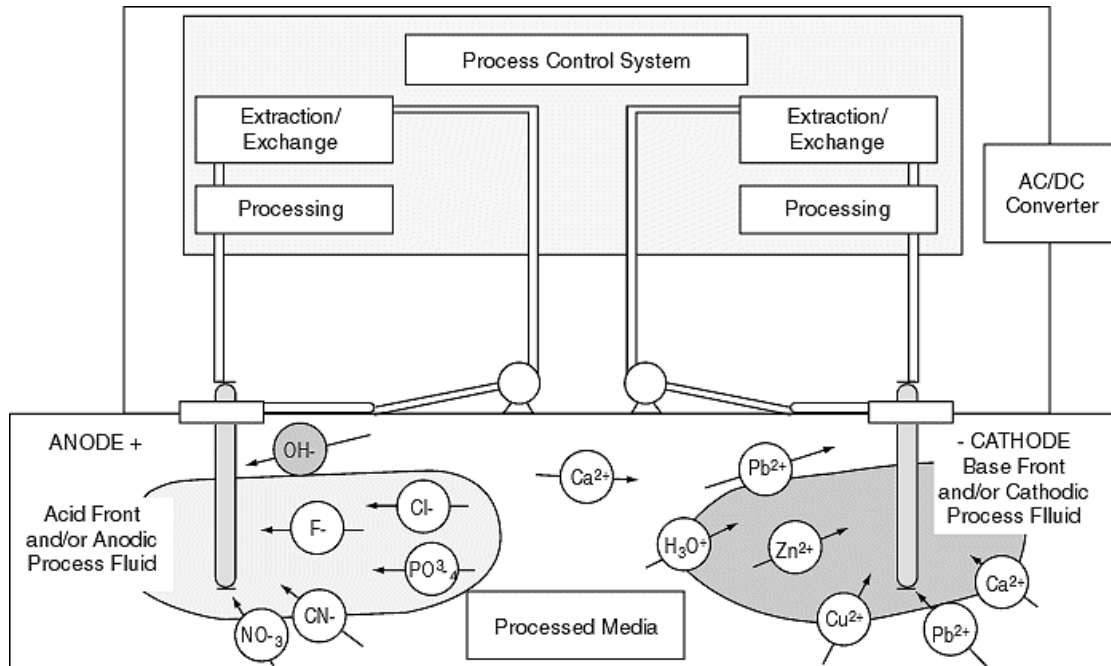

**Figure 3-15 Electrokinetic remediation process.**

Electrokinetic remediation is possible in saturated and unsaturated soils. The soil moisture content must be high enough to allow electromigration, but for optimum results, should be less than saturation, to avoid the competing effects of tortuosity and pore water content. Surfactants and complexing agents can be used in subsurface media to increase solubility and assist in the movement of the contaminants. Also, reagents may be introduced at the electrodes to enhance contaminant removal rates. The efficiency of metal removal by this process will be influenced by the type and concentration of contaminant, the type of soil, soil structure, and interfacial chemistry of the soil (U.S. EPA, 1997b and 1995a; Evanko and Dzombak, 1997). Conditions that can produce optimal electrokinetic performance include soil moisture near saturation, adequate pore water electroconductivity, metal solubility, low CEC, and low salinity (Van Cauwenberghe, 1997).

Equipment required for the *in situ* field application of this technology is of a fairly specialized nature. Anodes and cathodes are

placed in permeable or porous casings *in situ*.

The aboveground system requires a pump to remove contaminated water from the cathode to a processing system. Tanks and meters are needed for holding waste to be processed, and water solutions or chemical additives that are used *in situ*. A low voltage power supply is required. Other specialized equipment such as controllers, valves, vacuum pumps, and gauges may be required.

*In situ* electrokinetic remediation is primarily for the remediation of sites with low permeability and in order to overcome subsurface heterogeneities. Several variations of the electrokinetic process include:

- A technology called the “Pool Process” is used to remediate toxic heavy metals such as chromium. Through this process, ion-permeable electrolyte casings are placed in the contaminated media and connected to a centralized electrochemical ion-exchange (EIX) based electrolyte management system.

Each casing has an electrode inside. Together, these form alternating rows of anodes and cathodes. Electrolyte is circulated in a closed loop between the electrode casings and the EIX. Electrolysis of water in the electrolyte results in the formation of H<sup>+</sup> ions at the anodes and OH<sup>-</sup> at the cathodes. These ions migrate through the casing into the soil generating a temporary and localized pH shift that desorbs contaminating ions. Once desorbed, the contaminating ions migrate under the influence of the applied potential to their respective electrodes (anodes for anions, cathodes for cations). Here they pass through the electrode casing walls and are taken up by the circulating electrolytes. The pH at the anode and the cathode is managed by the addition of acid or alkali, as required. Contamination is selectively recovered from the circulating electrolytes as they pass through the EIX units. Soluble but benign elements are returned to the media. Periodically, the EIX units are regenerated by polarity reversal, which recovers the contamination in a concentrated and reusable form (U.S. EPA, 1997b).

- Another process operates similarly to the process described previously. It is potentially applicable to saturated and unsaturated soils. Conditioning pore fluids may need to be added to the soil matrix or circulated at the electrodes to control process electrochemistry. The process is being used to stimulate and sustain *in situ* bioremediation for treatment of organics and heavy metals. This is done by introducing nutrients and process additives to the subsurface.

Theoretically, the rate of additive transport and the efficiency of its dispersion in the subsurface matrix will be enhanced by the use of electrokinetics, especially at sites with aquifer heterogeneities (U.S. EPA, 1996a).

- An *in situ* electrokinetic extraction (ISEE) system is being developed that can be used to treat anionic heavy metals such as chromate in unsaturated soil without adding significant amounts of water to control process electrochemistry. Water is only circulated (added) to the electrode casing to help remove collected contaminants. Bench-scale studies have shown the technology to be effective in sandy soils with a moisture content as low as 7 percent. The technology can be expanded to treat saturated soils (U.S. EPA, 1996a).

Some of the potential advantages of the use of electrokinetic technology are listed below.

#### **Advantages**

- Effective method for inducing movement of water and ions through fine-grained, low-permeability, or heterogeneous soils that may be an obstacle to more traditional technologies.
- Mobilizes metal contaminants without use of strong acids for pH modification.
- May be used to remediate heavy metals contamination in unsaturated soils; technically and cost competitive.
- Applicable to a broad range of contaminants.

A number of potential limitations in using this technology exist; most of these limitations are site-specific. These limitations are listed below (Van Cauwenberghe, 1997):

#### **Limitations**

- The contaminant needs to be solubilized either by a dilute acid solution front or by a processing fluid in order for it to be extracted by most electrokinetic processes.

- Process is limited by the solubility of the contaminant and the desorption of contaminants from the soil matrix.
- Process may not be efficient for treating multiple metals if concentrations are significantly different.
- Incomplete remediation could result if there are areas of poor electrical conductivity (stagnant zones) between wells, or the contaminant migration path is long.
- Heterogeneities or subsurface anomalies such as building foundations or large rocks can reduce removal efficiencies.
- Immobilization of metal ions can occur by undesirable chemical reactions with naturally occurring and co-disposed chemical constituents.
- Heavy metals can prematurely precipitate close to the cathode.
- Excessive treatment depths may not be cost-effective for use of the technology.

### **3.5.2 Status**

Electrokinetic remediation is a developing innovative technology with a specialized nature. Its main focus has been the treatment of low permeability soils where other technologies would not be successful or their use may not be cost-effective. Because of its specialized nature,

relatively few commercial vendors apply the technology (Van Cauwenberghe, 1997).

The success of various electrokinetic remediation technologies for removal of metals, including chromium, from soils has been shown via bench- and pilot-scale experiments. Currently, several of these technologies are being implemented in comprehensive field-scale demonstration studies for further evaluation (Evanko and Dzombak, 1997).

A technology vendor using the Pool Process continues to perform several electrokinetics remediation projects both in the U.S. and abroad (see Table 3-7). The commercial scale electrokinetic remediation technology is mainly used for the extraction of toxic metals and toxic anions from soil and groundwater (U.S. EPA, 1997b). The technology has also been demonstrated under the Superfund Innovative Evaluation Technology (SITE) Program in chromate-contaminated soil at Sandia National Laboratories (SNL), in New Mexico (U.S. EPA, 1996a).

Other processes have also been demonstrated under the SITE Program. A field pilot-scale test was conducted at a site contaminated with lead, copper, and zinc. A field study of the ISEE Process was conducted at an unlined chromic acid pit within a landfill (U.S. EPA, 1996a).

**Table 3-7. Case Studies for the Pool Process**

Year	Location	Client	Description	
1997 – ongoing	Alameda Naval Air Station, California	U.S. Navy and EPA Office of Tech. Development	Pilot-scale recovery of Cr from former plating operations	ongoing
1996	California	Large U.S. industrial and communications company	Bench scale recovery of Cr from former plating operations	\$16,000
1992 – 1994	Temporary landfill at the Airbase of Woensdrecht, Germany	Ministry of Defense/DGWT	Formed on-site lagoon and <i>in situ</i> remediation of 3,400 yd <sup>3</sup> sludge contaminated with Cr, Ni, Cu, Zn, and Cd	\$1,040,000

### 3.5.3 Performance and Cost Data

Most of the applications of this technology to date have been for bench- or pilot-scale testing. There has been very little actual *in situ* remediation of chromium at full-scale using this technology. Electrokinetic remediation of metals *in situ* is still a developing technology. Due to the developing nature of the technology, available performance and cost data are estimated and should be used with caution.

The Pool Process has had the most application, mostly at sites in Europe, and often as an *ex situ* treatment or on sediment lagoons, not on undisturbed sites where some of the listed advantages of the technology can be evaluated. Investigators estimate that concentrations of target species in the range of 10 to 500 ppm can be reduced to less than 1 ppm. Remediation costs are expected to be in the range of \$200 to \$325/m<sup>3</sup> (\$150 to \$250/yd<sup>3</sup>) (Van Cauwenberghe, 1997).

Testing of another electrokinetics process has shown removal efficiencies between 75 and 95 percent for lead, chromium, cadmium, and uranium at levels up to 2,000 mg/kg (Van Cauwenberghe, 1997). Bench-scale testing at SDL in sandy soils at approximately 40 to 60 percent soil moisture saturation resulted in

removal by the process of 75 to 90 percent of the initial chromium (USEPA, 1995).

A field-scale demonstration of the ISEE System for treatment of chromate-contaminated soil was conducted at SDL under the SITE Program (USEPA, 1998). The ISEE System was developed to remove Cr(VI) from unsaturated soil. The field-scale demonstration results showed that the ISEE removed approximately 200 g of Cr(VI) during operation, and had an overall removal efficiency of approximately 0.14 g of Cr(VI) per kilowatt hour (kWh). However, comparison of pre- and post-treatment soil sample results did not show much improvement in Cr(VI) levels or TCLP levels in the treatment zone. The post-treatment median TCLP concentration of 20.4 mg/L exceeded the TCLP regulatory limit of 5.0 mg/L for the demonstration site. The total treatment costs for the ISEE System to treat 16 yd<sup>3</sup> of soil were estimated to be \$1,830/m<sup>3</sup> (\$1,400/yd<sup>3</sup>) for removing 200 g of Cr(VI). This cost will vary depending on cleanup goals, soil type, treatment volume, and system design changes. The ISEE System used for the SITE demonstration was a prototype. The treatment cost for a full-scale system should be significantly reduced due to design

improvements based on the SITE demonstration results (U.S. EPA, 1998).

The cost of using electrokinetic remediation is dependent on specific chemical and hydraulic properties present at the contaminated site. Cost is strongly influenced by soil conductivity because energy consumption is directly related to the conductivity of the soil between the electrodes. Electrokinetic treatment of soils with high electrical conductivities may not be feasible due to the high cost (Evanko and Dzombak, 1997). Estimated price ranges per unit of waste (non-specific) treated by various vendors include:

- DuPont R&D: \$85/m<sup>3</sup> (\$65/yd<sup>3</sup>)
- Electrokinetics, Inc.: \$25 to \$130/m<sup>3</sup> (\$20 to \$100/yd<sup>3</sup>)
- Geokinetics International: \$80 to \$300/m<sup>3</sup> (\$60 to \$225/yd<sup>3</sup>)

These price estimates do not include indirect costs associated with remediation, such as permits and treatment of residues (Van Cauwenberghe, 1997).

Other factors that have a significant effect on unit price are:

- Depth of contamination: greater treatment depth interval is more cost effective.
- Residual waste processing.
- Site preparation and system installation requirements.
- Local electricity and labor costs.

Pilot-scale field studies indicate that the energy consumption in extracting heavy metals from soil may be approximately 500 kW-hr/m<sup>3</sup> or more at an electrode spacing of 1.0 to 1.5 m. The direct energy cost would be approximately \$25/m<sup>3</sup> (\$20/yd<sup>3</sup>) or \$0.05/kW-hr at this level of energy consumption.

## 3.6 Natural Attenuation

### 3.6.1 Technology Description

The EPA accepted form of natural attenuation, “monitored natural attenuation,” refers to the reliance on natural attenuation processes (within the context of a carefully controlled and monitored site cleanup approach) to achieve site-specific remedial objectives within a time frame that is reasonable compared to that offered by other more active methods. The natural attenuation processes that are at work in such a remediation approach include a variety of physical, chemical, or biological processes that, under favorable conditions, act without human intervention to reduce the mass, toxicity, mobility, volume, or concentration of contaminants in groundwater. These *in situ* processes include biodegradation; dispersion; sorption; dilution; volatilization; and chemical or biological stabilization, transformation, or destruction of contaminants. Other commonly used terms referring to natural attenuation include “intrinsic remediation,” “intrinsic bioremediation,” “passive bioremediation,” “natural recovery” and “natural assimilation” (U.S. EPA, 1997d).

#### **Use of Natural Attenuation**

The use of monitored attenuation is not new to remediation. It has been incorporated in contaminant remediation plans since 1985. Since that time, monitored natural attenuation has continued, slowly increasing with greater program experience and scientific understanding of the processes involved. Though recent scientific advances have resulted in a heightened interest in this approach, complete reliance is appropriate only in a limited set of circumstances at contaminated sites (U.S. EPA, 1997d).

Natural attenuation processes are typically occurring at all sites, but to varying degrees of effectiveness depending on the types and concentrations of contaminants present and the

physical, chemical, and biological characteristics of the soil and groundwater. Natural attenuation processes may reduce the potential risk posed by site contaminants in a number of ways: the contaminant may be converted to a less toxic form through destructive processes such as biodegradation or abiotic transformations; potential exposure levels may be reduced by lowering of concentration levels by dilution or dispersion; contaminant mobility and bioavailability may be reduced by sorption to the soil or rock matrix; Cr(VI) may be reduced to the less toxic and mobile Cr(III) by natural reductants; and metal contaminants may be incorporated into the crystalline structure of a rock or mineral.

Following source control measures, natural attenuation may be sufficiently effective to achieve remediation objectives at some sites without the aid of other (active) remedial measures. Typically, however, natural attenuation will be used in conjunction with active remediation measures (U.S. EPA, 1997d). Natural attenuation is often applicable to sites that are not highly contaminated. Usually the source area has been treated through active remediation measures that are then followed with natural attenuation to complete the remediation of residual contamination.

Sorption and oxidation-reduction (redox) reactions are the dominant mechanisms responsible for the reduction of mobility, toxicity, or bioavailability of inorganic contaminants. It is necessary to know what specific mechanism is responsible for the attenuation of inorganic contaminants because some mechanisms are more desirable than others. In the case of chromium, it is critical to have an understanding of the Chromium Cycle in the environment. Changes in a contaminant's concentration, pH, redox potential, and chemical speciation may reduce a contaminant's stability at a site and release it into the environment. Determining the existence and demonstrating the irreversibility of these mechanisms are key components of a

sufficiently protective monitored natural attenuation remedy (USEPA, 1997d).

### **Site Characterization**

If natural attenuation is to be considered as a viable option for chromium contaminated sites, then ideally, it must be demonstrated that: (1) there are natural reductants present within the aquifer; (2) the amount of Cr(VI) and other reactive constituents does not exceed the capacity of the aquifer to reduce them; (3) the time scale required to achieve the reduction of Cr(VI) to the target concentration is less than the time scale for the transport of the aqueous Cr(VI) from the source area to the point of compliance; (4) the Cr(III) will remain immobile; and (5) there is no net oxidation of Cr (III) to Cr(VI). The most difficult information to obtain is the time scale for the reduction and oxidation of chromium in the soil (Palmer and Puls, 1994).

Decisions to employ monitored natural attenuation as a contaminant remedy or remedy component should be thoroughly and adequately supported with site-specific characterization data and analysis. In general, the level of site characterization necessary to support a comprehensive evaluation of natural attenuation is more detailed than that needed to support active remediation. For example, to assess the contributions of sorption, dilution, and dispersion to natural attenuation of chromium-contaminated groundwater requires a very detailed understanding of aquifer hydraulics, recharge and discharge areas and volumes, and chemical properties of the aquifer system (U.S. EPA, 1997d).

Once the site characterization data have been collected and a conceptual model developed, the next step is to evaluate the efficacy of monitored natural attenuation as a remedial approach. This approach would more likely be appropriate if the plume is not expanding or threatening downgradient wells or surface water bodies, and where ample potable water supplies are available.



## **Monitoring**

Performance monitoring is of even greater importance for monitored natural attenuation than for other types of remedies due to the longer remediation time frames, potential for ongoing contaminant migration, and other uncertainties associated with it. Monitoring programs developed for each site should specify the location, sampling frequency, and type of samples and measurements necessary to evaluate technology performance as well as define the anticipated performance objectives of the technology. Performance monitoring should continue as long as contamination remains above required cleanup levels. Additionally, monitoring is continued for a specified period after cleanup levels have been achieved to ensure that concentration levels are stable and remain below target levels (U.S. EPA, 1997d).

Demonstrating Cr(VI) reduction in the aquifer by mass balances that rely primarily on the aqueous concentrations from monitoring well networks is valid only if it is demonstrated that Cr(VI) precipitates are not forming in the aquifer. The monitoring network must be sufficiently dense to ensure that estimates of Cr(VI) are accurate (Palmer and Puls, 1994).

## **Contingency Remedy Technologies**

It is often suggested that a facility using natural attenuation as a remediation remedy have a contingency remedy established. A contingency remedy is a cleanup technology or approach specified in the site remedy decision document that functions as a “backup” remediation approach in the event that the “selected” remedy fails to perform as anticipated. It is also recommended that one or more criteria (“triggers”) be established, as appropriate, in the remedy decision document that will signal unacceptable performance of the selected remedy and indicate when to implement contingency measures (U.S. EPA, 1997d).

As chromium concentrations decrease while using conventional, active remedial procedures, it becomes more difficult to remove the remaining chromium. These active procedures

can also be very costly. In response to these obstacles, natural reductants have been identified that transform the more toxic hexavalent form of chromium to the less toxic trivalent form. Under alkaline to slightly acidic conditions (pH>4.0), Cr(III) precipitates as a fairly insoluble hydroxide, thereby immobilizing it (Bartlett and Kimball, 1976a). Such natural attenuation may mean that strict water-quality standards do not have to be attained everywhere within and beneath the site. For instance, conventional pump-and-treat remediation could desist after the most contaminated groundwater has been removed, even if the MCL has not been achieved, if it is anticipated through analysis that natural attenuation will deal with the residual contamination. Under certain circumstances, expensive remedial measures may not even be necessary (Palmer and Puls, 1994).

There are several soil tests that are useful in determining the mass of Cr(VI) and Cr(III) in the source areas and the reduction and oxidation capacities of the aquifer materials. Using conceptual models, this information, combined with knowledge of the residence time of the chromium between the source and the point of compliance, can be used to determine the feasibility of natural attenuation of Cr(VI). The major limitation to this approach is the lack of information about the rate of oxidation and reduction of chromium under conditions likely to be encountered by plumes emanating from chromium sources. Until better information is developed about these rate processes under a wider range of conditions with respect to pH, the use of natural attenuation for contaminated soils and groundwater will continue to be a highly debated issue (Palmer and Puls, 1994).

## **Advantages**

- Much less costly than other *in situ* remedial technologies.
- Can remove the low concentration levels of chromium that pump-and-treat systems are unable to remediate.

- Generation of lesser volume of remediation wastes, reduced potential for cross-media transfer of contaminants commonly associated with *ex situ* treatment, and reduced risk of human exposure to contaminated media.
- Less intrusion as few surface structures are required.
- Potential for application to all or part of a given site, depending on site conditions and cleanup objectives.
- Use in conjunction with, or as a follow-up to other (active) remedial measures.

### Limitations

- There is no single test that can tell if natural attenuation will occur at a particular site.
- There is a lack of information about the rate of oxidation and reduction of chromium under conditions likely to be encountered by plumes emanating from chromium sources.
- Longer time frames may be required to achieve objectives, compared to active remediation.
- Site characterization may be more complex and costly.
- Long-term monitoring on a routine basis will generally be necessary.
- Institutional controls may be necessary to ensure long-term protectiveness.
- Potential exists for continued contamination migration, and/or cross-media transfer of contaminants.
- Hydrologic and geochemical conditions amenable to natural attenuation are likely to change over time and could result in

renewed mobility of previously stabilized contaminants, adversely impacting remedial effectiveness.

- More extensive education and outreach efforts may be required in order to gain public acceptance of monitored natural attenuation.

### 3.6.2 Status

Beginning in the late 1980s and continuing through the 1990s, examination of the acceptance of natural attenuation at the state level showed that almost every state was reviewing its positions with thoughts of changing them. As of 1996, 38 states were considering changing their policies toward acceptance of natural attenuation. The primary impetus for changing attitudes is the rising costs for more “active” remediation techniques. Recently, there has been a slow accumulation of case histories demonstrating that groundwater is sometimes better cleaned by natural processes. Further examination reveals that in many cases, the health risks do not merit the expense of engineered remediation (Brady et al., 1998).

### 3.6.3 Performance and Cost Data

One of the most successful attempts at quantifying natural attenuation of Cr(VI) was at the Trinity Sand Aquifer in Texas. Cr(VI) from a number of chrome plating operations seeped into the aquifer between 1969 and 1978. Maps of the resulting plume (1986 and 1991) were analyzed to show that nearly three quarters of the Cr(VI) initially present had been removed, according to investigators. Fe(II) and aquifer organic matter were thought to be the primary reducing agents. The primary sink for chromium was thought to be the formation of Cr(OH)<sub>3</sub>. Using best estimates for the remaining hydrologic inputs, it was calculated that contaminant levels would decrease through natural attenuation to below MCLs within a decade (Brady, et al., 1998).

## **3.7 Phytoremediation**

### **3.7.1 Technology Description**

Phytoremediation uses plants to remediate contaminated soil and groundwater by taking advantage of the plants' natural abilities to take up, accumulate, and/or degrade inorganic and organic constituents. All plants extract, through their root systems, necessary nutrients, including metals from their soil and water environments. Some plants have the ability to store large amounts of metals, even some metals that do not appear to be required for plant functioning. Metal contaminants that have been remediated in laboratory and/or field studies using phytoremediation include Cr(VI), Cd, Pb, Co, Cu, Ni, Se, and Zn (Miller, 1996).

Phytoremediation technologies are applicable to sites with low to moderate soil contamination over large areas, and to sites with large volumes of groundwater with low levels of contamination that have to be cleaned to low standards. They are most effective if soil contamination is limited to within 3 feet of the surface, and if groundwater is within 10 feet of the surface. Groundwater contaminated with metals can be treated through the use of deep-rooted trees such as poplars to capture groundwater, uptake the metals, and retard contaminant migration (Miller, 1996). Phytoremediation may be used as a follow-up technique after areas having high concentration of pollutants have been mitigated, or in conjunction with other remediation technologies (USEPA, 1996).

### **3.7.2 Status**

Phytoremediation technologies are in the early stage of development, with laboratory research

and limited field trials being conducted to determine processes and refine methods. Full-scale remediation projects have not been completed and regulatory approval may be difficult to acquire (Miller, 1996). Like bioremediation and natural attenuation, mathematical modeling and monitoring are necessary to demonstrate the effectiveness of the technology to regulatory agencies (Schnoor, 1997). At the current stage of development, this process is best suited for sites with widely dispersed contamination at low concentrations where only treatment of soils at the surface (within depth of the root zone) is required. In the future, phytoremediation may provide a low cost option under specific circumstances for treatment of soils contaminated with metals (U.S. EPA, 1996).

### **3.7.3 Performance and Cost Data**

This technology is attractive because of its potentially low cost compared to more "active" remedial approaches. The tradeoff is the amount of time that is required to achieve treatment to clean-up levels. Cost estimates for phytoremediation vary widely. Limited cost and performance data are currently available. Using phytoremediation to clean up one acre of sandy loam to a depth of 50 cm typically will cost \$60,000 to \$100,000, compared with a cost of at least \$400,000 for excavation and disposal storage without treatment (Salt, 1995). The processing and ultimate disposal of the biomass generated is likely to be a major percentage of overall costs, particularly when highly toxic metals and radionuclides are present at a site (U.S. EPA, 1996).

## Section 4

### REFERENCES

- ABB Environmental Services. 1998a. Technical Memorandum 2, Townsend Saw Chain Site, Pontiac, South Carolina, from Robin Futch to Ralph Howard, USEPA. April 7, 1998.
- ABB Environmental Services. 1998b. Technical Memorandum 3, Townsend Saw Chain Site, Pontiac, South Carolina, from Robin Futch to Ralph Howard, USEPA. April 24, 1998.
- Allen, H.E., C.P. Huang, G.W. Bailey, and A.R. Bowers. 1995. *Metal Speciation and Contamination of Soil*. Lewis Publishers, Ann Arbor, Michigan: 7 through 9.
- American Wood Preservers Institute (AWPI). 1996. *The 1995 Wood Preserving Industry Production Statistical Report*. September 1996.
- Amonette, J.E., J.E. Szecsody, H.T. Schaef, J.C. Templeton, Y.A. Gorby and J.S. Fruchter. 1994. "Abiotic Reduction of Aquifer Materials by Dithionite: a Promising *In Situ* Remediation Technology". In *Proceedings of the 33<sup>rd</sup> Hanford Symposium on Health and the Environment - In Situ Remediation: Scientific Bases for Current and Future Technologies*. Battelle Press, Richland, WA. Pages 851-882.
- Bartlett, R. J. and J. M. Kimble. 1976a. "Behavior of chromium in soils: I. Trivalent forms." *Journal of Environmental Quality*. Vol. 5, No. 4. Pages 379 through 383.
- Bartlett, R. J. and J. M. Kimble. 1976b. "Behavior of chromium in soils: II. Hexavalent forms." *Journal of Environmental Quality*. Vol. 5, No. 4. Pages 383 through 386.
- Bartlett, R.J. 1991. "Chromium cycling in soils and water: Links, gaps, and methods." *Environmental Health Perspectives*. Vol. 92. Pages 17 through 24.
- Bowman, R.S., L. Zhaohui, S.J. Roy, T. Burt, T.L. Johnson, and R.L. Johnson. 1999. *Surface-altered Zeolites as Permeable Barriers for In Situ Treatment of Contaminated Groundwater*. Phase II Topical Report for the U.S. Department of Energy, Pittsburgh, Pennsylvania. August 1999.
- Brady, P., M. Brady, and D. Borns. 1998. "Natural Attenuation: CERCLA, RBCA's and the Future of Environmental Remediation." Lewis Publishers, Boca Raton, 1998.
- Brown, A.B., M.C. Leahy, and R.Z. Pyrih. 1998. "In situ Remediation of Metals Comes of Age." In *Remediation/Summer 1998*, John Wiley & Sons, Inc., 1998.
- Burdick, J.S., and D.L. Jacobs. 1998. "Field Scale Applications to Demonstrate Enhanced Transformations of Chlorinated Aliphatic Hydrocarbons". Presented at the *Northeast Focus Ground Water Conference*, October 20-21, 1998, pp. 131-145.
- Caccavo, F., R. Niels, and W. Costerton. 1996. "Morphological and Metabolic Responses to Starvation by the Dissimilatory Metal-Reducing Bacterium *Shewanella alga* BrY." *Applied and Environmental Microbiology*. December, 1996, Vol 62, No. 12, p 4678.
- Calder, L.M., 1988. "Chromium Contamination of Groundwater" In: *Chromium in the Natural and Human Environments*. Vol. 20 (J.O. Nriagu and E. Nieboer, editors). John Wiley & Sons, New York: 215 through 230.

- Cercona Inc. 1995. "Status Report -Test Results Using Cercona Iron Based Foams for Dehalogenation Chlorinated Solvents & Adsorption of Heavy Metals". *Contaminated Groundwater*. June 8, 1995.
- Cohen, R.M., A.H. Vincent, J.W. Mercer, C.R. Fourst, and C.P. Spalding. 1994. *Methods for Monitoring Pump-and-Treat Performance*. EPA/600/R-94/123.
- Cummings, M. and S. Booth. 1997. "Cost Effectiveness of *In situ* Redox Manipulation for Remediation of Chromium-Contaminated Groundwater." LA-UR-97-165. March, 1997.
- Dragun, J. 1988. *The Soil Chemistry of Hazardous Materials*. Hazardous Materials Control Research Institute. Silver Spring, Maryland. Pages 75 through 195.
- Evanko, C.R. and D.A. Dzombak. 1997. "Remediation of Metals-Contaminated Soils and Groundwater." Ground-Water Remediation Technologies Analysis Center, *Technology Evaluation Report*. October 1997.
- Federal Register. Vol. 61, No. 247, 40 CFR Part 300. National Priorities List for Uncontrolled Hazardous Waste Sites (FRL-5668-3) and National Priorities List for Uncontrolled Hazardous Waste Sites, Proposed Rule No. 21(FRL-5668-4). December 23, 1996.
- Fruchter, J. 1999. "*In Situ* Manipulation for Treatment of Chromate and TCE in Groundwater". Presentation for the USEPA Conference on *Abiotic In Situ Technologies for Groundwater Remediation*, Dallas, Texas. August, 1999.
- Griffin, R. A., A. K. Au, and R.R. Frost. 1977. "Effect of pH on Adsorption of Chromium from Landfill-Leachate by Clay Minerals." *Journal of Environmental Science Health*. Part A, Vol. 12, No. 8. Pages 431 through 449.
- Harding Lawson Associates. 1999. "Draft Final Remedial Design Report for the Townsend Saw Chain Site, Pontiac, South Carolina". Submitted to the USEPA, Region IV, September, 1999.
- Harding Lawson Associates. 2000. Preliminary injection monitoring results and revisions to the "Final Remedial Design Report for the Townsend Saw Chain Site, Pontiac, South Carolina". Received from Ralph Howard, USEPA Region IV RPM, July 27, 2000.
- Howard, R., 1998. EPA, Region IV. Personal communication with Remedial Project Manager. May 1998.
- Howard, R., 2000. EPA, Region IV. Personal Communication with RPM. Sept. 2000.
- James, B. R. and R. J. Bartlett. 1983a. "Behavior of Chromium in Soils: V. Fate of Organically Complexed Cr(III) Added to Soil." *Journal of Environmental Quality*. Vol. 12, No. 2. Pages 169 through 172.
- James, B. R. and Richmond J. Bartlett. 1983b. "Behavior of Chromium in Soils: VII. Adsorption and Reduction of Hexavalent Chromium Forms." *Journal of Environmental Quality*. Vol. 12, No. 2. Pages 177 through 181.
- Khan, F. 1999. "*In Situ* Treatment of Chromium Source Area Using Redox Manipulation". Presentation for the USEPA Conference on *Abiotic In Situ Technologies for Groundwater Remediation*, Dallas, Texas. August, 1999.
- Krauter, P., R. Martinelli, K. Williams and S. Martins. 1996. "Removal of Cr(VI) from Ground Water by *Saccharomyces cerevisiae*." *Biodegradation* 7: 277-286. March 1996.
- Lau, M. 2000. Personal communication by telephone on August 10, 2000 with the USEPA Region IX RPM for the Valley Wood Preserving Site.

- Lenzo, F. 1999. "Precipitation of Metals using Non-Microbial *In situ* Reactive Zones." Presentation for the USEPA Conference on *Abiotic In Situ Technologies for Groundwater Remediation*, Dallas, Texas. August, 1999.
- Manz, C. and K Quinn. 1997. "Permeable Treatment Wall Design and Cost Analysis." In *International Containment Technology Conference*. St. Petersburg, Florida, Feb. 9-12. Pages 788-793.
- Miller, R. R. 1996. *Phytoremediation*. "Ground-Water Remediation Technologies Analysis Center Technology Overview Report." October 1996.
- Nivas, B.T., D.A. Sabatini, B. Shiau, and J.H. Harwell. 1996. "Surfactant Enhanced Remediation of Subsurface Chromium Contamination." *Water Resources*, Vol. 30, No. 3. Pages 511 through 520.
- Nriagu, J.O. 1988. "Production and Uses of Chromium". *Chromium in the Natural and Human Environments*. Vol. 20 (J.O. Nriagu and E. Nieboer, editors). John Wiley & Sons, New York: 81 through 104.
- Nyer, E. and P. Palmer. 1997. "*In situ* Treatments Using Water as the Carrier." *Environmental Technology-Journal of Advanced Science and Engineering*. Vol 7, Issue 4. July/August 1997.
- Nyer, E. and S. Suthersan. 1996. "Treatment Technology: *In situ* Reactive Zones." *Ground Water Monitor Remediation*, Summer 1996, v16, no 3. Page 70.
- O'Hannesin, S. 1999. "An Overview of Installation Methods for PRBs". Presentation for the USEPA Conference on *Abiotic In Situ Technologies for Groundwater Remediation*, Dallas, Texas. August, 1999.
- Palmer, C. and R. Puls. 1994. *Natural Attenuation of Hexavalent Chromium in Ground Water and Soils*. EPA/540/S-94/505. U.S. Environmental Protection Agency Ground Water Issue. October 1994.
- Palmer, C.D. and W. Fish. 1992. *Chemical Enhancements to Pump-and-Treat Remediation*. U.S. Environmental Protection Agency Ground Water Issue: EPA/540/S-92/001. January 1992.
- Palmer, C.D. and P.R. Wittbrodt. 1991. "Processes Affecting the Remediation of Chromium-Contaminated sites." *Environmental Health Perspectives*. Vol. 92. Pages 25 through 40.
- Pintail Systems, Inc. "Biomineralization of Metals." [www.clu-in.com/site/ongoing](http://www.clu-in.com/site/ongoing). July 2, 1998.
- Puls, R. 2000. Review comments on draft document. July, 2000.
- Puls, R.W., C.J. Paul, and R.M. Powell. 1999. "The Application of *In Situ* Permeable Reactive (zero-valent iron) Barrier Technology for the Remediation of Chromate-Contaminated Groundwater: a Field Test." *Applied Geochemistry*. Vol. 14, Pages 989-1000.
- Richard, F.C. and A.C.M. Bourg. 1991. "Aqueous Geochemistry of Chromium: A Review." *Water Resources*. Vol. 25, No. 7. Pages 807 through 816.
- Ross, D.S., R.E. Sjogren, and R.J. Bartlett. 1981. "Behavior of Chromium in Soils: IV. Toxicity to Microorganisms." *Journal of Environmental Quality*. Vol. 10, Pages 145-148.
- Rouse, J.V. 1994. "In-Situ Remediation of Dissolved Chromate-Ion Contamination of Ground Water." *Paper presentation for the 87th Annual Meeting of the Air & Waste Management Association*. June 1994.
- Rouse, J.V. 1997. "Natural and Enhanced Attenuation of CCA Components in Soil and Groundwater." *Paper Presentation for the 93rd Annual Meeting of the American*

- Wood-Preservers' Association. April 27 through 29, 1997.
- Rouse, J.V., and R.Z. Pyrih. 1990. "In-Place Cleanup of Heavy Metal Contamination of Soil and Ground Water at Wood Preservation Sites." *Paper Presentation for the 86th Annual Meeting of the American Wood-Preservers' Association*. April through May 1990.
- Rouse, J.V., M.C. Leahy, and R.A. Brown. 1996. "A Geochemical Way to Keep Metals at Bay." *Environmental Engineering World*. May through June 1996.
- Rouse, J.V. Personal communication with Jim Rouse of Montgomery Watson on August 23, 1999.
- Rouse, J., E Benker, M. Daud, and D. Lam. 1999. "In-Situ Remediation of Chromium Contaminated Soil and Ground Water." *Proceedings, Contaminated Site Remediation: Challenges Posed by Urban and Industrial Contaminants*. Conference in Freemantle, Western Australia, sponsored by Centre for Groundwater Studies, CSIRO Land and Water, March 21-25, 1999. Pages 623-631.
- Rouse, J.V. 1999a. Monitoring data and results. *Draft Remediation System Progress Report, South Australia*. February 24, 1999.
- Sabatini, D.A., R.C. Knox, E.E. Tucker, and R.W. Puls. 1997. *Innovative Measures for Subsurface Chromium Remediation: Source Zone, Concentrated Plume, and Dilute Plume*. U.S. Environmental Protection Agency, *Environmental Research Brief*. EPA/600/S-97/005. September 1997.
- Sacre, J. 1997. *Treatment Walls: A Status Update*. Ground-water Remediation Technologies Analysis Center. April 1997.
- SAIC (Science Applications International Corporation). 1998. "Fact Sheet: Biomineral Barrier Technology." September 1998.
- Salt, D.E., et al. 1995. "Phytoremediation: A Novel Strategy for the Removal of Toxic Metals from the Environment Using Plants." *Biotechnology*. Volume 13, May. Pages 468 through 474.
- Schmelling, S. 1999. "Overview of Abiotic *In Situ* Groundwater Remediation Approaches". Presentation for the USEPA Conference on *Abiotic In Situ Technologies for Groundwater Remediation*, Dallas, Texas. August, 1999.
- Schnoor, J.L. 1997. "Phytoremediation." *Ground-Water Remediation Technologies Analysis Center Technology Evaluation Report*. October 1997.
- Steimle, R. 1997. "*In Situ* Flushing Team Meeting." *Ground-Water Remediation Technologies Analysis Center Presentation*. TP-97-04. May 1997.
- Stollenwerk, K. G. and D. B. Grove. 1985. "Adsorption and desorption of hexavalent chromium in an alluvial aquifer near Telluride, Colorado." *Journal of Environmental Quality*. Vol. 14, No. 1. Pages 150 through 155.
- Sturges, S.G., Jr., P. McBeth, and R.C. Pratt. 1992. "Performance of Soil Flushing and Groundwater Extraction at the United Chrome Superfund Site." *Journal of Hazardous Materials*, 29:59-78.
- Suthersan, S. 1997. *Remediation Engineering: Design Concepts*. Lewis Publishers, Boca Raton. 1997.
- Thomasser, R.M. 1999. Pilot study groundwater monitoring results. *Monthly, Quarterly, and Annual Status Reports to the USEPA, Region IX, 1999*.
- Thomasser, R.M. 2000a. Pilot study groundwater monitoring results. *Quarterly Status Report to the USEPA, Region IX, July 14, 2000*.

- Thomasser, R.M. 2000b. Remedial program and monitoring results. *Combined Fourth Quarter and Annual Report for 1999*. January 15, 2000.
- Thomasser, R.M., and J.V. Rouse. 1999. "In Situ Remediation of Chromium Contamination of Soil and Ground Water". *Paper presentation for the American Wood Preservers Association, May, 1999 Conference on Assessment and Remediation of Soil and Ground Water Contamination at Wood Treating Sites*.
- Tremaine, J. 1999. "In Situ Remediation of Hexavalent Chromium in Groundwater: Practical Implementation." Presentation for the USEPA Conference on *Abiotic In Situ Technologies for Groundwater Remediation*, Dallas, Texas. August, 1999.
- U.S. Environmental Protection Agency. 1995. *In Situ Remediation Technology Status Report: Electrokinetics*. EPA 542-K-94-007. April 1995.
- U.S. Environmental Protection Agency. 1995a. *In situ Remediation Technology Status Report: Treatment Walls*. EPA 542-K-94-004. April 1995.
- U.S. Environmental Protection Agency. 1996. Report: *Recent Developments for In Situ Treatment of Metals-Contaminated Soils*. U.S. Environmental Protection Agency, Office of Solid Waste and Emergency Response, draft.
- U.S. Environmental Protection Agency. 1996a. *Superfund Innovative Technology Evaluation Program Technology Profiles, Ninth Edition*. EPA/540/R-97/502. December 1996.
- U.S. Environmental Protection Agency. 1996b. *Permeable Barriers Actions Team*. EPA 542-F-96-010C. September 1996.
- U.S. Environmental Protection Agency. 1997. *Technology Alternatives for the Remediation of Soils Contaminated with As, Cd, Cr, Hg, and Pb*. Engineering Bulletin. EPA/540/S-97/50. August 1997.
- U.S. Environmental Protection Agency. 1997a. *Permeable Reactive Subsurface Barriers for the Interception and Remediation of Chlorinated Hydrocarbon and Chromium (VI) Plumes in Ground Water*. U.S. EPA Remedial Technology Fact Sheet. EPA/600/F-97/008. July 1997.
- U.S. Environmental Protection Agency, 1997b. *Electrokinetic Laboratory and Field Processes Applicable to Radioactive and Hazardous Mixed Waste in Soil and Groundwater*. EPA/402/R-97/006. USEPA Office of Radiation and Indoor Air. July 1997.
- U.S. Environmental Protection Agency. 1997c. *Treatment Technology Performance and Cost Data for Remediation of Wood Preserving Sites*. EPA/625/R-97/009. October 1997.
- U.S. Environmental Protection Agency. 1997d. "Use of Monitored Natural Attenuation at Superfund, RCRA Corrective Action, and Underground Storage Tank Sites." Directive 9200.4-17. November 1997.
- U.S. Environmental Protection Agency. 1998. *In Situ Electrokinetic Extraction System, Sandia National Laboratories*. Technology Capsule. EPA/540/R-97/509a. December 1998.
- U.S. Environmental Protection Agency. 1999. *Field Applications of In Situ Remediation Technologies: Permeable Reactive Barriers*. EPA 542-R-99-002. June 1999.
- U.S. Environmental Protection Agency. 1999a. *An In Situ Permeable Reactive Barrier for the Treatment of Hexavalent Chromium and Trichloroethylene in Ground Water: Volume 1 Design and Installation*. EPA/600/R-99/095a. September 1999.
- U.S. Environmental Protection Agency. 1999b. *An In Situ Permeable Reactive Barrier for*



- the Treatment of Hexavalent Chromium and Trichloroethylene in Ground Water: Volume 2 Performance Monitoring.* EPA/600/R-99/095b. September 1999.
- U.S. Environmental Protection Agency. 1999c. *An In Situ Permeable Reactive Barrier for the Treatment of Hexavalent Chromium and Trichloroethylene in Ground Water: Volume 3 Multicomponent Reactive Transport Modeling.* EPA/600/R-99/095c. September 1999.
- Van Cauwenberghe, L., 1997. *Electrokinetics.* Technology Overview Report, Ground-Water Remediation Technologies Analysis Center. July 1997.
- Vance, D. 1997. "Reactive Barriers to Treat Areas Adjacent to Source Zone." *Environmental Technology-Journal of Advanced Science and Technology.* Vol 7, Issue 4. July/August 1997.
- Vidic, R. and F. Pohland. 1996. *Treatment Walls.* Ground-water Remediation Technologies Analysis Center. October 1996.
- Walker, W. 1999. "Chromium Reduction/Fixation at the Townsend Saw Chain Site." Presentation for the USEPA Conference on *Abiotic In Situ Technologies for Groundwater Remediation*, Dallas, Texas. August, 1999.
- Williams, M.D., V.R. Vermeul, J.E. Szecsody, J.S. Fruchter and C.R. Cole. 1998. *100-D Area In Situ Redox Treatability Test for Chromate - Contaminated Groundwater FY 1998 Year-End Report.* Subsurface Contaminant Focus Area, Office of Technology Development, U.S. Department of Energy, Washington. D.C. PNNL-12153.
- Yin, Yujun and H.E. Allen. 1999. *In Situ Chemical Treatment.* Technology Evaluation Report TE-99-01 prepared for the Ground-Water Remediation Technologies Analysis Center. July, 1999.
- Zachara, J. M., C.E. Cowen, R.L. Schmidt, and C.C. Ainsworth. 1988. "Chromate Adsorption by Kaolinite." *Clays and Clay Minerals.* Vol. 36, No. 4. Pages 317 through 326.
- Zachara, J.M., C.C. Ainsworth, C.E. Cowan, and C.T. Resch. 1989. "Adsorption of Chromate by Subsurface Soil Horizons." *Soil Science Society American Journal.* Vol. 53, Pages 418-428. March-April 1989.
- Zhaohui, L., H.K. Jones, R.S. Bowman, and R. Helfferich. 1999. "Enhanced Reduction of Chromate and PCE by Pelletized Surfactant-Modified Zeolite/Zerivalent Iron." *Environmental Science and Technology*, Vol. 33, No. 23. Pages 4326-4330.

## APPENDIX A

### SOURCES OF ADDITIONAL INFORMATION

This section lists sources that may be useful to the reader to locate additional information about *in situ* chromium contamination and remediation technologies. Many of these sources, but not all of them, were referred to during the preparation of this guide. Some of these sources may only address organic forms of site contamination.

#### ***COMPLETED NORTH AMERICAN INNOVATIVE REMEDIATION TECHNOLOGY DEMONSTRATION PROJECTS.***

***UNITED STATES ENVIRONMENTAL PROTECTION AGENCY. EPA 542-B-96-002. AUGUST 12, 1996***

Analyzes and summarizes information for close to 300 completed demonstration soil and groundwater remediation projects, including those performed, co-sponsored, or funded through programs developed by EPA, U.S. military services, DOE, Canadian government, and States of California and New Jersey. Information includes contaminants treated, technology type, media, vendor, project sponsor, reports available, and contacts.

#### ***ALTERNATIVE TREATMENT TECHNOLOGIES INFORMATION CENTER (ATTIC)***

(703) 908-2138

[WWW.EPA.GOV/ATTIC](http://WWW.EPA.GOV/ATTIC)

Provides access to a collection of hazardous waste databases. Information includes hazardous waste abstracts, news bulletins, conference information, and a message board. Remediation technology information is catalogued by contaminant.

#### ***CLEANUP INFORMATION (CLU-IN) BULLETIN BOARD***

(301) 598-8366

[WWW.EPA.GOV/CLUIN](http://WWW.EPA.GOV/CLUIN)

Database with current groundwater remediation technology information. Information includes bulletins, message and on-file exchange, and on-line databases and directories. Downloadable documents, abstracts, etc.

#### ***VENDOR INFORMATION SYSTEM FOR INNOVATIVE TREATMENT TECHNOLOGIES (VISITT)***

(800) 245-4505

[WWW.PRCEMI.COM/VISITT](http://WWW.PRCEMI.COM/VISITT)

Contains current information about the availability, performance, and cost of innovative technologies to remediate hazardous waste sites.

#### ***WATERLOO HOME PAGE***

[HTTP://DARCY.UWATERLOO.CA/HOME.HTML](http://DARCY.UWATERLOO.CA/HOME.HTML)

Only a scaled down version is available now.

### **REMEDIAION TECHNOLOGIES DEVELOPMENT FORUM (RTDF)**

[HTTP://WWW.RTDF.ORG](http://www.rtdf.org)

Contains information on the Bioremediation Consortium, Lasagna Partnership, INERT Soil-Metals Action Team, Phytoremediation of Organics Action Team, Permeable Reactive Barriers Action Team, *In situ* Flushing Action Team, and the Sediments Remediation Action Team.

### **GROUND-WATER REMEDIATION TECHNOLOGIES ANALYSIS CENTER**

[HTTP://WWW.GWRTAC.ORG](http://www.gwrtac.org)

A national environmental technology transfer center that provides information on the use of innovative technologies to clean-up contaminated groundwater.

### **SUPERFUND INNOVATIVE TECHNOLOGY EVALUATION (SITE) PROGRAM**

[HTTP://WWW.EPA.GOV/ORD/SITE](http://www.epa.gov/ord/site)

Contains information on innovative remediation technologies which includes technology profiles, program highlights, technical documents, and project status.

### **REMEDIAION AND RESTORATION AT UCLA'S CENTER FOR CLEAN TECHNOLOGY**

[HTTP://CCT.SEAS.UCLA.EDU/CCT.RR.HTML](http://cct.seas.ucla.edu/cct.rr.html)

Involves research and development in Transport and Transformation Technology, Simulation and Management Models, and Risk Assessment and Risk Management Frameworks. Site information includes brief descriptions of current research.

### **LAWRENCE LIVERMORE NATIONAL LABORATORY – ENVIRONMENTAL TECHNOLOGIES PROGRAM**

[HTTP://WWW-EP.ES.LLNL.GOV/WWW-EP/AET.HTML](http://www-ep.es.llnl.gov/www-ep/aet.html)

Fundamental and applied research on environmental topics including remediation technologies. Remediation focus areas include (1) *in situ* thermal remediation, including Dynamic Underground Stripping and *in situ* electrical heating methods, and (2) *in situ* bioremediation, including an *in situ* Microbial Filter method. Information provided about these technologies include descriptions of concepts and processes, field test results, and points of contact. Science and technology articles, including remediation issues, available on-line.

### **PACIFIC NORTHWEST NATIONAL LABORATORY (PNNL) TECHNOLOGY ABSTRACTS**

[HTTP://W3.PNL.GOV:2080/TRANSFER/T2HOME.HTML](http://w3.pnl.gov:2080/transfer/t2home.html)

On-line technology briefs and fliers about technologies available for licensing from PNNL. Technologies include *in situ* bioremediation, *in situ* vitrification. Remedial Action Assessment Software (RAAS), and *in situ* corona.

### **PACIFIC NORTHWEST LABORATORIES ProTECH (PROSPECTIVE TECHNOLOGIES) ONLINE**

[HTTP://GII-AWARDS.COM/NICAMPGN/244A.HTML](http://gii-awards.com/nicampgn/244a.html)

ProTech is a graphical communication application used by DOE's Office of Technology Development to describe information on over 150 innovative environmental technologies being developed and demonstrated at DOE sites. Information provided includes technical summaries of ongoing or planned site characterization and remediation technology applications at DOE facilities.

**USEPA ROBERT S. KERR ENVIRONMENTAL RESEARCH LABORATORY, NOW KNOWN AS SUBSURFACE PROTECTION REMEDIATION DIVISION (SPRD)**

[HTTP://WWW.EPA.GOV/ADA/KERRLAB.HTML](http://www.epa.gov/ada/kerrlab.html)

Bibliography with abstracts of scientific and technical publications developed by and through the SPRD relating to groundwater protection, fate and transport, and remediation. Information packets on bioremediation and other related topics are also available. Houses the Center for Subsurface Modeling Support (CSMoS), which provides free groundwater modeling software and services.

**USDOE OFFICE OF ENVIRONMENTAL MANAGEMENT**

[HTTP://WWW.EM.DOE.GOV](http://www.em.doe.gov)

Information about DOE's technology needs in the areas of characterization, storage, and disposal of hazardous radioactive wastes. Information on technology at DOE sites. Directory of technologies and points of contacts relating to sites and technologies.

**CANADIAN CENTER FOR INLAND WATERS GROUNDWATER REMEDIATION PROJECT**

[HTTP://GWRP.CCIW.CA/GWRP](http://gwrp.cciw.ca/gwrp)

Bibliography and abstracts of recent publications, covering groundwater remediation and related topics. Groundwater modeling and analysis software is also available.

**GLOBAL NETWORK FOR ENVIRONMENTAL TECHNOLOGIES**

[HTTP://WWW.GNET.ORG](http://www.gnet.org)

Contains extensive information under the "Technology Center" subsite.

**NATIONAL HYDROLOGY RESEARCH INSTITUTE (NHRI) ENVIRONMENT CANADA**

[HTTP://GWRP.CCIW.CA/NHRI/NHRIGW.HTML](http://gwrp.cciw.ca/nhri/nhrigw.html)

Investigation of natural processes in subsurface environments and development of remedial techniques for cleanup and containment of toxic contaminants. Research briefs include topics such as the effects of microbial biofilms on organic contaminants and *in situ* barriers for groundwater remediation and containment.

**GROUNDWATER AND SITE REMEDIATION CSIRO-AUSTRALIA, INCLUDING CENTER FOR GROUNDWATER STUDIES**

[HTTP://WWW.DWR.CSIRO.AU](http://www.dwr.csiro.au)

Brief description of current research and a bibliographic listing of publications (1985-1996) on topics such as natural BTEX biodegradation, enhanced bioremediation, trichloroethylene, munitions, aquifer bioclogging, and others.

**HAZARDOUS SUBSTANCE RESEARCH CENTER**

[HTTP://WWW.GTRI.GATECH.EDU/HSRC](http://www.gtri.gatech.edu/hsrc)

Research projects involve finding innovative technologies to remediate hazardous organic contaminants. Research topics include *in situ* bioremediation, surfactants, and bioventing. Also contains an accessible site and infrastructure for filed projects. Includes research project abstracts, research briefs, points of contact, and other publications.

**UNIVERSITY OF IDAHO CENTER FOR HAZARDOUS WASTE REMEDIATION RESEARCH**

[HTTP://UIDAHO.EDU/~CRAWFORD/CENTER2.HTML](http://uidaho.edu/~crawford/center2.html)

Focuses on the characterization of contaminated sites and the development and field application of novel technologies for hazardous waste remediation. Remediation technologies addressed include bioremediation and geochemical remediation. Site includes a bibliography of representatives.

**STANFORD HYDROGEOLOGY RESEARCH GROUP**

[HTTP://PANGEA.STANFORD.EDU/HYDRO/HYDRO.HTML](http://pangea.stanford.edu/hydro/hydro.html)

Current research topics include in-Well Vapor Stripping, Optimal Remedial Design, and Aquifer Heterogeneity. Information about these topics includes research abstracts and references.

**WATERNET**

[HTTP://WATERNET.COM](http://waternet.com)

Articles from Water Technology and International Ground Water Technology journals, including remediation and related topics.

**CENTER FOR GROUNDWATER RESEARCH (CGR) OREGON GRADUATE INSTITUTE OF SCIENCE AND TECHNOLOGY (OGI)**

[HTTP://WWW.ESE.OGI\\_DOCS/CGR.HTML](http://www.ese.ogi_docs/cgr.html)

Provides brief descriptions and points of contact for research activities being conducted at OGI, including "Research on Contaminant Remediation with Zero-Valent Iron Metal."

**NATIONAL INSTITUTE OF ENVIRONMENTAL HEALTH SCIENCES SUPERFUND BASIC RESEARCH PROGRAM (SBRP)**

[HTTP://NIEHS.NIH.GOV/SBRP/HOME.HTML](http://niehs.nih.gov/sbrp/home.html)

Presents brief highlights of their research activities, at universities across the country, in areas including remediation and bioremediation.

**BERKELEY ENVIRONMENTAL RESTORATION CENTER**

[HTTP://BERC3.ME.BERKELEY.EDU](http://berc3.me.berkeley.edu)

Includes abstracts of student research in the areas of remediation and fate and transport.

**THE CENTER FOR ENVIRONMENTAL BIOTECHNOLOGY (CEB)**

[HTTP://WWW.RA.UTK.EDU](http://www.ra.utk.edu)

Information includes a list and brief descriptions of current research projects, and contacts for further information.

**USEPA OFFICE OF RESEARCH AND DEVELOPMENT**

Bulletin Board Service (513) 569-7610

Provides a bibliography of over 19,000 documents and a message board.

**CENTER FOR ENVIRONMENTAL RESEARCH INFORMATION (CERI) – TECHNOLOGY TRANSFER**

[WWW.EPA.GOV/TTBNRMRL](http://www.epa.gov/ttbnrmrl)

Provides information and documents concerning the latest developments for environmental technologies and problems including monitoring, treatment, and other research.

***DIALOG DATABASE***

(800) 3-DIALOG

Contains files relevant to hazardous waste including Enviroline, CA Search, Pollution Abstracts, Compendex, Energy Science and Technology, National Technical Information Service (NTIS), etc. NTIS Database contains abstracts of government-sponsored research, development, and engineering analysis prepared by approximately 250 Federal agencies and some state and local governments.

***SOIL AND GROUNDWATER MAGAZINE (FORMERLY SOILS MAGAZINE)***

[HTTP://WWW.GVI.NET](http://www.gvi.net)

Current and back issues containing relatively brief articles on remediation and related topics.

***NATURAL ATTENUATION: CERCLA, RBCA'S, AND THE FUTURE OF ENVIRONMENTAL REMEDIATION***

PATRICK V. BRADY, MICHAEL V., BRADY, DAVID J. BORN. LEWIS PUBLISHERS, 1998

Book analyzes the historical evolution and current direction of environmental remediation in the United States and outlines why there is now and will be an increasing reliance on natural attenuation of hazardous substance toxicity in the coming years.

## **APPENDIX B**

# **TECHNOLOGY AND VENDOR CONTACT INFORMATION**

## TECHNOLOGY AND VENDOR CONTACT INFORMATION

Technology/Vendor	Contact Person	Address	
Geochemical Fixation/Montgomery Watson	Jim Rouse	370 Interlocken Blvd. Suite 300 Broomfield, CO 80021	303-410-4029 <a href="mailto:Jim.V.Rouse@mw.com">Jim.V.Rouse@mw.com</a>
Geochemical Fixation	Ralph Howard, RPM	EPA Region IV Atlanta Federal Center 100 Alabama Street, S.W. Atlanta, Georgia 30303	404-562-8829 <a href="mailto:howard.ralph@epa.gov">howard.ralph@epa.gov</a>
PRBs	Dr. Robert Puls	EPA Subsurface Protection and Remediation Division National Risk Management Research Laboratory Ada, OK 74820	580-436-8543 <a href="mailto:puls.robert@epa.gov">puls.robert@epa.gov</a>
PRBs/Waterloo Centre for Groundwater Research	Dr. David Blowes or Dr. Robert Gillham	Department of Earth Sciences University of Waterloo Ontario, N2L 3G1, Canada	519-888-4878 <a href="mailto:blowes@sciborg.uwaterloo.ca">blowes@sciborg.uwaterloo.ca</a> 519-888-4658 <a href="mailto:rwgillha@sciborg.uwaterloo.ca">rwgillha@sciborg.uwaterloo.ca</a>
PRBs/ISRM	Dr. John Fruchter	Battelle Pacific NW Lab PO Box 999 Richland, WA 99352	509-376-3937 <a href="mailto:john.fruchter@pnl.gov">john.fruchter@pnl.gov</a>
PRBs/Zeolite & ZVI	Dr. Robert Bowman	Dept. Of Earth and Environmental Science New Mexico Tech 801 Leroy Place Socorro, NM 87801	505-835-5992 <a href="mailto:bowman@nmt.edu">bowman@nmt.edu</a>
PRBs/Cercona of America, Inc.	Richard Helferich President	5911 Wolf Creek Pike Dayton, OH 45426	937-854-9860 <a href="mailto:rhelferich@coax.net">rhelferich@coax.net</a>
Reactive Zones/Arcadis Geraghty & Miller	Dr. Suthan Sutherson or Frank Lenzo	3000 Cabot Blvd. West Suite 300 Langhorne, PA 19047	215-752-6840 <a href="mailto:ssuthers@gmgw.com">ssuthers@gmgw.com</a> <a href="mailto:flenzo@gmgw.com">flenzo@gmgw.com</a>
Biom mineralization/Pintail Systems, Inc.	Leslie Thompson	11801 E. 33 <sup>rd</sup> Avenue Suite C Aurora, CO 80010	303-367-8443
Soil Flushing & Chromium Extraction	Dr. David Sabatini	Institute for Applied Surfactant Research University of Oklahoma Norman, OK 73019	405-325-4273 <a href="mailto:sabatini@mailhost.ecn.uo.knor.edu">sabatini@mailhost.ecn.uo.knor.edu</a>



<b>Technology/Vendor</b>	<b>Contact Person</b>	<b>Address</b>	
Soil Flushing & Chromium Extraction	Richard Steimle	U.S. EPA Technology Innovation Office 5702G, 401 M Street SW Washington DC 20460	703-603-7195 <a href="mailto:steimle.rich@epa.gov">steimle.rich@epa.gov</a>
Electrokinetics	Randy Parker	U.S. EPA National Risk Management Research Laboratory 26 W. Martin Luther King Dr. Cincinnati, OH 45268	513-569-7271 <a href="mailto:parker.randy@epa.gov">parker.randy@epa.gov</a>
Electrokinetics/Geokinetics International, Inc.	Robert Clarke or Stuart Smedley	829 Heinz Street Berkeley, CA 94710	510-704-2940 <a href="mailto:edarobert@aol.com">edarobert@aol.com</a>
Electrokinetics/ Electrokinetics, Inc.	Elif Acar or Robert Gale	11552 Cedar Park Ave. Baton Rouge, LA 70809	504-753-8004 <a href="mailto:ekinc@pipeline.com">ekinc@pipeline.com</a>
Electrokinetics/Sandia National Laboratories	Eric Lingren	P.O. Box 5800 Albuquerque, NM 87185	505-844-3820 <a href="mailto:erlindg@sandia.gov">erlindg@sandia.gov</a>
Natural Attenuation	Dr. Robert Puls	U.S. EPA Subsurface Protection and Remediation Division National Risk Management Research Laboratory Ada, OK 74820	580-436-8543 <a href="mailto:puls.robert@epa.gov">puls.robert@epa.gov</a>
Phytoremediation/ Phytotech, Inc.	Michael Blaylock or John Ehrler	One Deer Park Drive Suite 1 Monmouth Junction, NJ 08852	908-438-0900 <a href="mailto:soilrx@aol.com">soilrx@aol.com</a> or <a href="mailto:johnehrler@aol.com">johnehrler@aol.com</a>