



EPA 453/R-06-001
September 2006

Control Techniques Guidelines: Industrial Cleaning Solvents

This page intentionally left blank.

EPA 453/R-06-001
September 2006

Control Techniques Guidelines: Industrial Cleaning Solvents

Sector Policies and Programs Division
Office of Air Quality Planning and Standards

U.S. Environmental Protection Agency
RTP, NC

This page intentionally left blank.

TABLE OF CONTENTS

<u>Section Title</u>	<u>Page No.</u>
I. Introduction.....	1
II. Background and Overview	2
III. Applicability	5
IV. State and Local Regulatory Approaches.....	6
V. Recommended Control Options.....	7
A. Recommended Control Measures	7
1 Work Practices	7
2 VOC Content Limit.....	8
3 Alternative Composite Vapor Pressure Limit.....	8
B. Suggested Exclusions.....	8
1 Categories Listed for Regulation under CAA Section 183(e)	8
2 Categories with Specific Exemptions under Bay Area 8-4-116	9
3 Categories with Specific Exemptions under Bay Area 8-4-117	9
4 Categories with Special Limits in South Coast AQMD Rule 1171(c) and exemptions in 1171(h)	9
VI. Impacts of Recommended Controls.....	10
VII. References.....	12
Appendix A. 1994 Control Techniques Guidelines: Industrial Cleaning Solvents	A-1
Appendix B. Summary of Regulations in California Reviewed for Industrial Solvent Cleaning CTG	B-1
Appendix C. Summary of NAICS Codes for nonattainment facilities estimated to meet the applicability criteria recommended in the CTG.....	C-1
Appendix D. Number of nonattainment facilities organized by State that are estimated to meet the applicability criteria recommended in the CTG.....	D-1
Appendix E. Costs and Emission Reductions for the Recommendation Concerning Solvent Substitution	E-1

NOTICE

This report is issued by the Sector Policies and Programs Division of the Office of Air Quality Planning and Standards, U.S. Environmental Protection Agency to provide information to State and local air pollution control agencies. Mention of trade names and commercial products is not intended to constitute endorsement or recommendation for use. Copies of this report are available as supplies permit-from the Library Services Office (at 541-2777 or library.rtp@epa.gov) of the U S. Environmental Protection Agency, Research Triangle Park, North Carolina 27711 They can also be downloaded from the FDMS e-docket websited (www.fdms.gov) by searching under Docket No. EPA-HQ-OAR-0535 or, for a nominal fee, from the National Technical Information Service, 5285 Port Royal Road, springfield VA 22161 (800) 553-NTIS)

This page intentionally left blank.

I. Introduction

Clean Air Act (CAA) section 172(c)(1) provides that state implementation plans (SIPs) for nonattainment areas must include “reasonably available control measures” (RACM), including “reasonably available control techniques” (RACT), for sources of emissions. Section 182(b)(2) provides that for certain nonattainment areas, States must revise their SIPs to include RACT for sources of VOC emissions covered by a control techniques guidelines document (CTG) issued after November 15, 1990 and prior to the area’s date of attainment.

The United States Environmental Protection Agency (EPA) defines RACT as “the lowest emission limitation that a particular source is capable of meeting by the application of control technology that is reasonably available considering technological and economic feasibility.” 44 FR 53761 (Sept. 17, 1979). In subsequent Federal Register notices, EPA has addressed how states can meet the RACT requirements of the Act. Significantly, RACT for a particular industry is determined on a case-by-case basis, considering issues of technological and economic feasibility.

CAA section 183(e) directs EPA to list for regulation those categories of products that account for at least 80 percent of the VOC emissions, on a reactivity-adjusted basis, from consumer and commercial products in areas that violate the NAAQS for ozone (i.e., ozone nonattainment areas). EPA issued such a list on March 23, 1995, and has revised the list periodically. *See* March 23, 1995 (60 FR 15264); *see also* 71 FR 28320 (May 16, 2006), 70 FR 69759 (Nov. 17, 2005); 64 FR 13422 (Mar. 18, 1999). Industrial cleaning solvents are included on the current section 183(e) list.

This CTG is intended to provide state and local air pollution control authorities information that should assist them in determining RACT for industrial cleaning solvents. In developing this CTG, EPA, among other things, evaluated the sources of VOC emissions from the use of industrial cleaning solvents and the available control approaches for addressing these emissions, including the costs of such approaches. Based on available information and data, EPA provides recommendations for determining RACT for the categories at issue in this document.

States can use the recommendations in this CTG to inform their own determination as to what constitutes RACT in their particular areas. The information contained in this document is provided only as guidance. This guidance does not change, or substitute for, applicable sections of the CAA or EPA’s regulations; nor is it a regulation itself. This document does not impose any legally binding requirements on any entity. It provides only recommendations for state and local air pollution control agencies to consider in determining RACT. State and local pollution control agencies are free to implement other technically-sound approaches that are consistent with the CAA and EPA’s implementing regulations

The recommendations contained in this CTG are based on data and information currently available to EPA. These general recommendations may not apply to a particular situation based upon the circumstances of a specific source. Regardless of whether a State chooses to implement the recommendations contained herein through State rules, or to issue State rules that adopt different approaches for RACT for VOCs for offset lithographic printing and letterpress printing, States must submit their RACT rules to EPA for review and approval as part of the SIP process. EPA will evaluate the rules and determine, through notice and comment rulemaking in the SIP process, whether they meet the RACT requirements of the Act and EPA's regulations. To the extent a State adopts any of the recommendations in this guidance into its State RACT rules, interested parties can raise questions and objections about the substance of this guidance and the appropriateness of the application of this guidance to a particular situation during the development of the State rules and EPA's SIP approval process.

CAA section 182(b)(2) provides that a CTG issued after November 15, 1990 and before the date of attainment must include the date by which States must submit SIP revisions in response to the CTG. States subject to section 182(b) should submit their SIP revisions within one year of the date of issuance of this final CTG. States subject to CAA section 172(c)(1) may take action in response to this guidance, as necessary to attain.

The remainder of this document is divided into five (5) sections. Section II Provides Background and Overview, which lists the cleaning (unit) operations associated with industrial cleaning solvents and identifies the sources of VOC emissions from those cleaning operations. Section III describes the emissions threshold that applies to this CTG. Section IV summarizes state and local regulatory approaches for addressing such emissions. Section V describes the available control options for addressing VOC emissions and lists categories of industries we are recommending for exclusion from this CTG. This information supplements the survey of state CTG summarized in Appendix B of the 1994 ACT. Section VI provides our proposed recommendations for RACT for industrial cleaning solvents, and discusses the cost-effectiveness of the recommended controls. Section VII provides references.

II. Background and Overview

This category of consumer and commercial products includes the industrial cleaning solvents used by many industries. It includes a variety of products that are used to remove contaminants such as adhesives, inks, paint, dirt, soil, oil, and grease. Contaminants are removed from parts, products, tools, machinery, equipment, vessels, floors, walls, and other work production related work areas for a variety of reasons including safety, operability, and to avoid product contamination. The cleaning solvents used in these (unit) operations are, in many cases, generally available bulk solvents that are used for a multitude of applications not limited to cleaning. For example, petroleum distillates may be used as a cleaning solvent, as a paint thinner, or as an ingredient used in the manufacture of a coating, such as paint. Because a portion of all solvents

evaporate during use, such solvent-based cleaning materials result in large amounts of emissions of VOC.

In 1994, EPA completed a study of industrial cleaning solvents that characterized cleaning operations carried out within six focus industries (automotive, electrical equipment, magnetic tape, furniture, packaging, and photographic supplies) to evaluate sources of evaporative emissions from VOC solvents used as cleaning materials. (See Reference 1 in the reference section for the full citation to these documents.)

We believe that the range of cleaning activities performed in these focus industries provided a good variety of cleaning operations for the study, and that the information obtained relevant to VOC emission sources and possible control techniques can be applied to virtually any industry.

Data collected by EPA during the development of the 1994 Alternative Control Techniques (ACT) (to be referred to as 1994 ACT or ACT) document for industrial cleaning solvents show nationwide usage of VOC solvent from six industries studied is more than 360,000 Mg/yr (400,000 tpy).¹ We also reported in the ACT document that the estimated total VOC solvent usage for cleaning by all U.S. industry was more than 910,000 Mg/yr (1 million tpy). This number was estimated using multiple sources, and not based on data from the facilities we surveyed. In general, VOC emissions occur from industrial cleaning solvents through evaporation during cleaning activities such as wiping, flushing, and brushing, as well as from storage and disposal of used shop towels and solvent.

The 1994 ACT included as Appendix A to this CTG. The document provides a thorough discussion of cleaning activities and types of cleaning operations in a wide and diverse assortment of industrial facilities, frequently used cleaning solvents, and the practices (or lack of) for managing solvents. It, also, identifies a methodology for estimating VOC emissions by cleaning operation, discusses control techniques for addressing such emissions, the costs-benefit of setting up a solvent accounting and management system, and other items.

EPA surveyed 34 facilities in the six focus industries and collected approximately 300 individual cleaning data sets or unit operation systems (UOS) representing emissions from the nine types of cleaning unit operations (UO) in the focus industries for the ACT document. These nine UO are identified below together with the VOC emission distribution based on the UOS material balance data:

- 1 Spray Gun Cleaning (50 percent);
- 2 Spray Booth Cleaning (14 percent);
- 3 Large Manufactured Components Cleaning (14 percent);
- 4 Parts Cleaning (7.0 percent);
- 5 Equipment Cleaning (6.9 percent);
- 6 Line Cleaning (3.6 percent);
- 7 Floor Cleaning (2.9 percent);

- 8 Tank Cleaning (0.82 percent); and
- 9 Small Manufactured Components Cleaning (0.44 percent).

Because spray gun cleaning (one of the UO) accounted for 50 percent of the emissions from cleaning operations, the ACT dedicated appendix G of the document to describe procedures for determining, in a consistent way, VOC emissions from a number of subcategories of spray gun cleaning. The subcategories represented the range of gun cleaning practices in the focus industries in 1994. However, due to the availability of enclosed gun cleaners today, states have disallowed gun cleaning methods that result in high solvent emissions.

The purpose of identifying these UO is to assist State and local agencies in identifying the sources of VOC emissions from cleaning activities and to provide a structure for developing and applying control techniques to mitigate VOC emissions from industrial cleaning solvents used in these UO. This CTG is intended to cover all industrial cleaning operations. EPA believes that all categories of industrial cleaning operations are represented or can be classified under one of the nine cleaning categories listed in this CTG. See also ACT (describing nine UO in further detail). EPA has not, to date, identified any industrial cleaning activity that would not fall within one of the nine UO, but even if such a situation occurred, this CTG is intended to cover all industrial cleaning operations irrespective of whether they can be properly categorized as one of the nine UO. That said, we recognize that there are several cleaning operations that may already be the subject of regulatory requirements, and we urge States to consider the specific industries and operations in their jurisdictions and any existing regulatory requirements applicable to those operations and tailor their RACT rules in response to this CTG accordingly. Finally, janitorial supplies used for cleaning offices, bathrooms or other similar areas are not covered by this CTG.

The ACT document provided a quantitative overview of cleaning solvents used and a model for accounting and tracking solvent usage--a solvent management system. It also provided a methodology for calculating emissions in a consistent way. A brief outline on how to manage emissions from cleaning operations is presented in Fig 4-1 of the ACT (see Appendix A).

Although the industrial cleaning solvent product category includes a variety of different products with differing VOC contents, and although these products are used in different ways by a wide range of industries, we believe that there are several basic approaches to achieve VOC emission reductions. First, the users of the products can control emissions through work practices targeted at the activities and sources of emissions specific to the user's industry (e.g., keeping solvent containers covered, properly storing and disposing of used shop towels and solvent, etc.). Second, users can also reduce overall VOC emissions through solvent substitution (e.g., use of low - VOC, no -VOC, or low -vapor pressure solvents). They can also reduce VOC emissions by using add-on controls, modifying equipment, or upgrading to using a lower emitting cleaning technology.

Theoretically, solvent substitution could be achieved at the point of manufacture or at the point of use, but in practice it is usually the user who selects the solvent or mixture of solvents to use in the various industrial cleaning operations throughout a facility. These general approaches are effective strategies to achieve significant emission reductions from this product category, notwithstanding the variation in the products, their users, and their specific uses.

III. Applicability (Scope of Sources)

This CTG applies to industries that have to use organic solvent for cleaning unit operations such as mixing vessels (tanks), spray booths, and parts cleaners, where a facility emits at least 6.8 kg/day (15 lb/day) of VOC before consideration of controls in an ozone nonattainment area. The cleaning activities for removal of foreign material from substrate being cleaned include actions (activities) such as wiping, flushing, or spraying.

The applicability threshold of 6.8 kg/day (15 lb/day) of VOC is consistent with the threshold level contained in many previous final CTGs. It is also consistent with the purpose of the section 183(e) program. In section 183(e), Congress directed EPA to assist States in achieving VOC emission reductions from consumer and commercial products. These products individually may result in relatively small amounts of VOC emissions, but, in the aggregate, they contribute significantly to ozone formation in nonattainment areas. Given the nature of the products and sources at issue here, we believe that the 6.8 kg/day (15 lb/day) of VOC per day applicability threshold is appropriate. For purposes of determining whether this threshold is met at a given facility performing industrial cleaning operations, the facility should consider the VOC emissions from the use of organic solvent cleaning prior to controls.

Some industries with solvent cleaning operations are presently covered by an existing CTG (e.g., aerospace). Other industries with solvent cleaning operations may be the subject of a CTG that is presently being developed (e.g., printing) or may be the subject of a future CTG (e.g., automobiles and light trucks coatings). CTGs often recommend control approaches for a particular industry, like printing, and those approaches achieve important VOC emission reductions. We recommend that States consider excluding from the applicability of their State rules promulgated in response to this CTG, those industries relevant to the product categories listed for regulation under CAA section 183(e). See 71 FR 44540. We list below the section 183(e) industries that the States may wish to consider excluding from the applicability of their State rules. States should also consider the structure of the Bay Area cleaning solvent rule, which ensures that particular cleaning activities are only subject to one set of requirements, as opposed to duplicative requirements. For example, under the Bay area structure, there is a cleaning exemption that is common to all Bay Area AQMD rules. There are cleaning standards found in each individual rule, such as metal parts and products, plastic parts, etc. The exemption exempts cleaning that is subject to Regulation 8, Rule 16, which governs cleaning in vats, containers, cold cleaners, vapor degreasers, etc, in which there is some standing liquid, either in the cleaning area or a remote reservoir. "The only intent

here is to make it clear that only one rule applies to a type of cleaning operation.” For example, cleaning a metal part by dipping in liquid solvent is subject to a 50 g/l standard in Reg. 8, Rule 16. Wipe cleaning that same part is subject to a 50 g/l standard in Reg. 8, Rule 19. Cleaning of spray booths by solvent wiping, a stationary structure would be subject to the architectural coating rule, Regulation 8, Rule 3. Consequently, a State may wish to exclude industrial categories to parallel the Bay Area rule overall structure or may wish to follow a structure where all the wipe cleaning and cleaning in a container are kept together and then address the specific needs of various types of substrates all within the wipe cleaning standards. The South Coast AQMD is one example of a California district that uses this format (e.g., AQMD Rule 1171(c)).

We estimate that there are approximately 7360 facilities in nonattainment areas for 8-hour ozone standards of which 2520 would be potentially affected because they meet the 6.8 kg/day (15 lb/day) of VOC applicability threshold for this CTG. Of these facilities, we estimate that approximately 1290 are located in areas for which RACT is required under section 182(b) of the CAA. We derived these number based on available information concerning the use of industrial cleaning solvents from the 2002 EPA National Emissions Inventory. The cost aspects are presented in greater detail in Appendix E.

IV. State and Local Regulatory Approaches

We reviewed regulations issued by three different local air pollution control authorities in California. These regulations are aimed at reducing VOC emissions from industrial cleaning solvents by combining work practice standards and placing limits on the VOC content of the solvent used. They also provided as an additional option the use of add-on controls. The work practice standards are similar for the air pollution control authorities. However, the VOC content limits required for certain applications and the add-on control overall efficiency level that would need to be met, vary by district. Appendix B presents a summary of the industrial solvent cleaning regulations in the three California air pollution control districts.

EPA also reviewed various State rules including:

- 1 Michigan;
- 2 Florida;
- 3 New Jersey; and
- 4 Indiana.

The above State rules do not require VOC content limits. Instead, equipment standards, work practices, and recordkeeping are required by sources. Regulations in these States on parts cleaners have an overall similar structure. However, there are specific differences. For example, the New Jersey rule applies to cold cleaning machines that use 2 gallons or more of solvents with greater than 5 percent (by mass) VOC. This is similar to a VOC limit of approximately 50 g VOC/liter. Both New Jersey and Illinois do not allow the use of solvents with a vapor pressure greater than 1 mm Hg (at 68 degrees

F) in parts cleaners --“cold cleaning machines.” The other States listed do not have similar provisions.

V. Recommended Control Options

The recommended measures for controlling emissions of VOC from the use, storage, and disposal of industrial cleaning solvents includes work practice standards, limitations on VOC content of the cleaning materials, and an optional alternative limit on composite vapor pressure of the cleaning materials. They also include the use of add-on controls with an overall emission reduction of at least 85 percent by mass. The first two recommendations and the last one are based on the Bay Area AQMD rule. Following the section discussing recommended control measures is a discussion of the industrial categories that we are recommending that States and local agencies consider excluding from applicability of these recommended control measure.

States can adopt these recommendations and include them in their SIP revisions or adopt RACT rules that provide for different approaches. For example, for a given industrial sector or cleaning operation, where appropriate, a State may offer the flexibility of requiring only work practices. Regardless of the approach a State pursues in its RACT rule, EPA will review the State RACT rule as part of the SIP approval process and will make the final determination as to whether the State rule comports with the RACT requirements of the Act.

When developing RACT measures for industrial cleaning operations, we suggest specific category exclusions, similar to the ones provided for the Bay Area and South Coast rules and that State and local agencies consider the specific industries and operations in their jurisdictions and the individual requirements of those operations and tailor their rules to those specific scenarios accordingly.

Furthermore, in considering existing cleaning requirements as bases for specific exemptions from their general industrial cleaning solvents rules, State and local agencies should take into account how current those measures are. EPA believes that more recent rules are likely to be more effective than older, possibly outdated, rules. We remind the States that the ultimate determination of whether any specific State or local measures meet any applicable RACT requirement will occur during the notice and comment rulemaking process associated with EPA action on SIP submissions. For ease of reference, in discussing the control recommendations below, we refer to the nine unit operations that we believe are representative of all industrial cleaning operations.

A. Recommended Control Measures

1. Work Practices

Recommended work practices that will help reduce VOC emissions from the use, handling, storage, and disposal of cleaning solvents and shop towels include:

- 1 Covering open containers and used applicators;
- 2 Minimizing air circulation around cleaning operations;
- 3 Properly disposing of used solvent and shop towels; and
4. Implementing equipment practices that minimize emissions (e.g., keeping arts cleaners covered, maintaining cleaning equipment to repair solvent leaks, etc.).

2. VOC Content Limit

We recommend a generally applicable VOC content limit of 50 grams VOC per liter (0.42 lb/gal) of cleaning material for each of the nine cleaning UO identified in the Background and Overview section, unless emissions are controlled by an emission control system with an overall control efficiency of at least 85 percent. This limit is modeled on the “general use” category of the Bay Area AQMD solvent cleaning regulations, taking into account the specific exclusions provided for in the Bay Area AQMD rule and described below.

3. Alternative Composite Vapor Pressure Limit

In addition to the recommended VOC content limit, EPA is recommending inclusion of a composite vapor pressure limit of 8 millimeters of mercury (mmHg) at 20 degrees Celsius, as (1) a replacement for the 50 g/l VOC content limit entirely; or (2) an alternative limit that may be used in lieu of the 50 g/l VOC content limit for specific operations as determined by the State or local agency.

B. Suggested Exclusions

This section includes product categories that EPA has listed for regulation under section 183(e) as well as categories of cleaning operations that are specifically excluded from applicability in Bay Area Regulation 8 rule 4. The Bay Area exclusions are provided as examples for consideration by the State and local agencies.

1. Categories Listed for Regulation under CAA Section 183(e)

We recommend that the States exclude from applicability those cleaning operations in the following categories listed for regulation under CAA section 183(e):

- 1 Aerospace coatings;
- 2 Wood furniture coatings;
- 3 Shipbuilding and repair coatings;
- 4 Flexible packaging printing materials;
- 5 Lithographic printing materials;
- 6 Letterpress printing materials;
- 7 Flat wood paneling coatings;

- 8 Large appliance coatings;
- 9 Metal furniture coatings;
- 10 Paper film and foil coating;
- 11 Plastic parts coatings;
- 12 Miscellaneous metals parts coatings;
- 13 Fiberglass boat manufacturing materials;
- 14 Miscellaneous industrial adhesives; and
- 15 Auto and light-duty truck assembly coatings.

2. Categories with Specific Exemptions under Bay Area 8-4-116

- 1 Electrical and electronic components;
- 2 Precision optics;
- 3 Numismatic dies;
- 4 Stripping of cured inks, coatings, and adhesives;
5. Cleaning of resin, coating, ink, and adhesive mixing, molding, and application equipment;
- 5 Research and development laboratories;
- 6 Medical device or pharmaceutical manufacturing; and
- 7 Performance or quality assurance testing of coatings, inks, or adhesives.

3. Categories Subject to Specific Rules and Exemptions under Bay Area 8-4-

117

- 1 Architectural coating;
- 2 Metal container, closure, and coil coating;
- 3 Paper, fabric, and film coating;
- 4 Light and medium duty motor vehicle assembly plants;
- 5 Surface coating of metal furniture and large appliances;
- 6 Surface coating of miscellaneous metal parts and products;
- 7 Graphic arts printing and coating operations;
- 8 Coating of flat wood paneling and wood flat stock;
- 9 Magnet wire coating operations;
- 10 Aerospace assembly and component coating operations;
- 11 Semiconductor wafer fabrication operations;
- 12 Surface coating of plastic parts and products;
- 13 Wood products coating;
- 14 Coating, ink, and adhesive manufacturing;
- 15 Flexible and rigid disc manufacturing;
- 16 Marine vessel coating;
- 17 Motor vehicle and mobile equipment coating operations; and
- 18 Polyester resin operations.

Appendix C provides a summary of NAICS Codes for nonattainment facilities estimated to meet the applicability criteria recommended in this CTG.

4. Categories with special limits in South Coast AQMD Rule 1171(c)

In addition to the Bay Area exclusions, and as discussed earlier, the more stringent South Coast AQMD “general use” limit of 25 g/l (0.21 lb/gal) is accompanied by higher limits for several individual operations. Although we are not recommending higher limits for these categories beyond the 50 g/l limit in this CTG, State and local agencies should be aware of the individual performance requirements in these categories when developing individual State or local cleaning solvent rules based on the specific industries within their jurisdictions. We suggest that State and local agencies refer to the South Coast rule for more details on subcategories and specific limits. The broad categories are:

1. Product cleaning during manufacturing process or surface preparation for coating;
2. Repair and maintenance cleaning;
3. Cleaning of coatings or adhesives application equipment;
4. Cleaning of ink application equipment; and
5. Cleaning of polyester resin application equipment.

VI. Impacts of Recommended Controls

EPA estimates that there are approximately 2,524 facilities in ozone nonattainment areas that would be affected by this CTG. These facilities had emissions that exceed the emission threshold of 6.8 kg (15 lb) of VOC per day. Total aggregate VOC emissions from solvent cleaning operations from these nonattainment sources are approximately 64,000 Mg/yr (71,000 tpy). Appendix D summarizes the potential number of facilities and their emissions that may be subject to this CTG by State.

EPA used studies published by the Bay Area AQMD to estimate the cost of compliance for the measures recommended in this CTG. According to these estimates, EPA believes that affected sources may either incur minimal additional costs or realize a savings on a case - by - case basis, depending primarily on facts such as how much they currently spend to operate high-VOC content solvent - based parts cleaners, and the cost of organic solvent disposal. The Bay Area AQMD studies indicate that there is a cost savings associated with replacing high-VOC cleaning materials with low-VOC, waterbased cleaning materials.

The total VOC emissions from solvent cleaning operations (64,000 Mg/yr (71,000 tpy) were determined by first assigning the VOC emissions from solvent cleaning operations at each facility using the 2002 National Emissions Inventory (NEI) database to one of two general groups: parts cleaners, and other solvent cleaning operations. The parts cleaner subgroup included emissions from all SCC codes with a “degreasing” or cold solvent cleaning/stripping classification in SCC_L3. VOC emissions from this subcategory are approximately 4,000 Mg/yr (4,400 tpy). The other solvent cleaning operations included all other SCCs that were identified as solvent cleaning operations. The VOC emissions from the other subgroup are approximately 60,000 Mg/yr (66,000

tpy). These emissions do not include emissions from halogenated parts cleaners. Consistent with our recommendations to the States, we did not include in these emissions those from facilities represented by the 183(e) source categories listed in section V. They also do not include remissions from research and development facilities, or emissions from manufacturing and assembly of electrical and electronic components.

Costs associated with switchover to aqueous parts cleaners (cleaning systems or washers) include the initial cost of equipment, solvent costs, filters, electricity, and waste disposal costs. Many of these costs are also incurred when operating higher VOC solvent cleaners. A study on parts cleaners, for example, has shown typical annual costs for mineral spirits parts cleaners as \$1,453. Estimates on annual costs for aqueous parts cleaners, in comparison, range from \$1,171 to \$1,480, thus showing that facilities could either face a slight increase in cleaning costs or realize a cost savings as a result of the switchover.⁶

Facilities may either incur minimal additional costs or realize a savings on a case-by-case basis, depending primarily on how much they currently spend to operate the high VOC content solvent-based parts cleaners, the cost of organic solvent disposal, and air emission fees levied for VOC emissions. A study provided by the California Bay Area AQMD shows that the cost-effectiveness for meeting the 50 grams of VOC per liter of cleaning material limit for a parts cleaner is estimated at \$1,832/Mg (1,664/ton).^{6,7} This represents the annual cost of compliance (industry wide) for parts cleaners (Table 4 of the Bay Area Regulation 8, Rule 16). We determined that replacing high VOC content cleaning materials with low VOC water-based cleaning materials for the other cleaning (unit) operations (e.g., cleaning of large manufactured surfaces, tank cleaning, and gun cleaning, etc.) would result in an estimated cost savings of \$1,460/Mg. For this calculation we only considered the cost-difference in cleaning material cost and cost-difference in waste disposal cost. The savings is a result of lower cost of aqueous cleaners which offset the increase in waste disposal cost for aqueous cleaners. Appendix E explains how we calculated the cost of applying the solvent substitution option for reducing VOC emissions from the use of organic cleaning solvents.

As explained above, this CTG is guidance for the States to use in determining RACT for VOC from industrial cleaning solvents. State and local pollution control agencies are free to implement other technically-sound approaches for RACT that are consistent with the CAA and EPA's implementing regulations. Accordingly, there is necessarily some uncertainty in any prediction of costs and emission impacts associated with the recommendations in this document. Nevertheless, assuming that States adopt the recommendations in this CTG or comparable approaches, EPA anticipates a net cost savings. We based this prediction on an assumption that substitution of low-VOC materials for high-VOC materials is possible for all uses. Because this assumption is not true for some applications, this prediction may not be valid in all cases.

VII. References

1. U.S. Environmental Protection Agency, *Alternative Control Techniques Document—Industrial Cleaning Solvents*, February 1994. EPA-453/R-94-015. (NTIS PB 94-181-694).
2. Bay Area Air Quality Management District, Regulation 8, Rule 16: *Solvent Cleaning Operations*. [http:// www.arb.ca.gov/DRDB/BA/CURHTML/R8-16.PDF](http://www.arb.ca.gov/DRDB/BA/CURHTML/R8-16.PDF), (Accessed June 27, 2006).
3. South Coast Air Quality Management District, Rule 1171: *Solvent Cleaning Operations*.
4. Sacramento Metropolitan Air Quality Management District, Rule 466: *Solvent Cleaning*.
5. U.S. Environmental Protection Agency, *Control of Volatile Organic Emissions from Solvent Metal Cleaning*, November 1977. EPA-450/2-77-022.
6. Bay Area Air Quality Management District, Staff Report: *Proposed Amendments to BAAQMD Regulation 8, Rule 16: Solvent Cleaning Operations, September 2002*.
7. South Coast Air Quality Management District, *Staff Report for Proposed Amendment to Rule 1171 - Solvent Cleaning Operations*, August 15, 1996.

Appendix A

1994 Control Techniques Guidelines: Industrial Cleaning Solvents

This page intentionally left blank

**United States
Environmental Protection
Agency**

**Office of Air Quality
Planning and Standards
Research Triangle Park NC 27711**

**EPA-453/R-94-015
February 1994**

Air



Alternative Control Techniques Document-- Industrial Cleaning Solvents

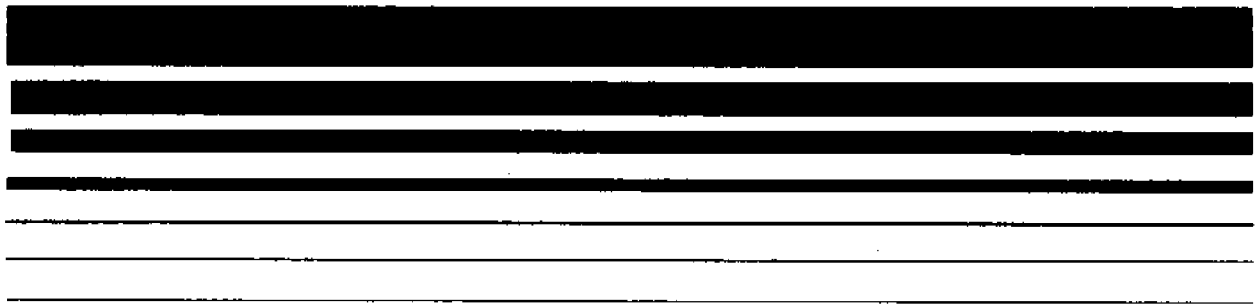

ACT

EPA-453/R-94-015

Alternative Control Techniques Document-- Industrial Cleaning Solvents

Emission Standards Division

**U. S. Environmental Protection Agency
Emission Standards Division
Research Triangle Park, NC 27711**

February, 1994

ALTERNATIVE CONTROL TECHNIQUES DOCUMENTS

This report is issued by the Emission Standards Division, Office of Air Quality Planning and Standards, U. S. Environmental Protection Agency, to provide information to State and local air pollution control agencies. Mention of trade names and commercial products is not intended to constitute endorsement or recommendation for use. Copies of this report are available--as supplies permit--from the Library Services Office (MD-35), U. S. Environmental Protection Agency, Research Triangle Park, North Carolina 27711 ([919] 541-2777) or, for a nominal fee, from the National Technical Information Service, 5285 Port Royal Road, Springfield, VA 22161 ([800] 553-NTIS).

TABLE OF CONTENTS

	<u>Page</u>
1.0 EXECUTIVE SUMMARY	1-1
2.0 INTRODUCTION	2-1
3.0 INDUSTRIAL CLEANING WITH ORGANIC SOLVENTS	3-1
3.1 OVERVIEW OF CLEANING	3-2
3.1.1 Cleaning Mechanisms	3-2
3.1.2 Description of Cleaning Activities	3-3
3.1.3 Factors that Affect Emissions	3-8
3.2 INDUSTRIES THAT USE VOC SOLVENTS FOR CLEANING	3-10
3.2.1 Quantitative Overview of Cleaning Solvents Use	3-10
3.2.2 Accounting/Tracking Procedures	3-14
3.2.3 Cleaning Solvent Use and Emissions in the Focus Industries	3-17
3.3 REFERENCES FOR CHAPTER 3	3-27
4.0 SOLVENT ACCOUNTING AND MANAGEMENT SYSTEMS	4-1
4.1 SOLVENT ACCOUNTING SYSTEM	4-4
4.2 SOLVENT MANAGEMENT	4-6
4.2.1 Testing of Alternative Solvents	4-7
4.2.2 Plant Management Actions	4-9
4.2.3 State Agency Actions	4-10
4.3 REFERENCES FOR CHAPTER 4	4-12
5.0 COSTS OF INSTITUTING ACCOUNTING AND MANAGEMENT	5-1
5.1 PLANTWIDE CASE STUDY COSTS	5-1
5.1.1 Qualitative Cost Information	5-2
5.1.2 Solvent Accounting Costs	5-5
5.1.3 Cost of Pollution Reduction Techniques	5-7
5.2 REFERENCES FOR CHAPTER 5	5-9
APPENDIX A. TERMS AND DEFINITIONS FOR SOLVENT CLEANING	A-1
APPENDIX B. REVIEW AND SUMMARY OF STATE AND LOCAL CLEANING REGULATIONS	B-1
APPENDIX C. UNIT OPERATION APPROACH	C-1
APPENDIX D. AMERICAN AUTOMOBILE MANUFACTURERS ASSOCIATION (AAMA) PROPOSAL	D-1
APPENDIX E. CASE STUDIES	E-1
APPENDIX F. DRAFT TEST METHOD FOR DETERMINING THE PERFORMANCE OF ALTERNATIVE CLEANING FLUIDS	F-1
APPENDIX G. PROCEDURES FOR DETERMINING VOC EMISSIONS FROM SPRAY GUN CLEANING	G-1
APPENDIX H. SPRAY GUN CLEANING PROCEDURES AND MATERIAL BALANCE CALCULATIONS FOR PAINT SPRAY GUN UOS AT CASE STUDY PLANT L	H-1

LIST OF FIGURES

<u>Number</u>		<u>Page</u>
1-1.	Distribution of nationwide emissions in the focus industries	1-3
3-1.	Distribution of nationwide emissions in the focus industries	3-26
4-1.	Controlling cleaning solvent usage	4-2

LIST OF TABLES

<u>Number</u>		<u>Page</u>
1-1	EXAMPLE PLANT MANAGEMENT AND STATE AGENCY ACTIONS	1-6
3-1	ESTIMATES OF THE AMOUNT OF VOC CLEANING SOLVENT USED BY INDUSTRY, x 10 ³ tons/yr	3-11
3-2	ESTIMATES OF THE AMOUNT OF VOC CLEANING SOLVENT USED BY INDUSTRY, x 10 ³ Mg/yr	3-12
3-3	AGENCY DATA GATHERING EFFORT	3-13
3-4	FREQUENTLY USED INDUSTRIAL CLEANING SOLVENTS	3-15
3-5	VOLUME OF SALES FOR COMMON CLEANING SOLVENTS	3-16
3-6	FREQUENCY OF UNIT OPERATION SYSTEM OCCURRENCE	3-19
3-7	UNIT OPERATION SYSTEMS REPORTED BY THE FOCUS INDUSTRIES	3-20
3-8	NATIONWIDE VOC SOLVENT USAGE ESTIMATES FOR FOCUS INDUSTRIES, (tons/yr)	3-22
3-9	NATIONWIDE VOC SOLVENT USAGE ESTIMATES FOR FOCUS INDUSTRIES, (Mg/yr)	3-23
3-10	NATIONWIDE VOC EMISSION ESTIMATE FOR FOCUS INDUSTRIES, (tons/yr)	3-24
3-11	NATIONWIDE VOC EMISSION ESTIMATE FOR FOCUS INDUSTRIES, (Mg/yr)	3-25
4-1	EXAMPLE PLANT MANAGEMENT AND STATE AGENCY ACTIONS	4-8
5-1	SUMMARY OF SOLVENT ACCOUNTING COSTS	5-3
5-2	SUMMARY OF POLLUTION REDUCTION TECHNIQUE COSTS	5-4

1.0 EXECUTIVE SUMMARY

Congress, in the Clean Air Act Amendments of 1990 (CAAA), supplemented previous mandates regarding control of ozone in nonattainment areas. A new Subpart 2 was added to Part D of Title I. Section 183(c) of the new Subpart 2 provides that:

...the Administrator shall issue technical documents which identify alternative controls for all categories of stationary sources of volatile organic compounds ... which emit, or have the potential to emit 25 tons per year or more of such air pollutant.

This report provides, alternative control techniques (ACT) for State and local agencies to consider for incorporating in rules to limit emission of volatile organic compounds (VOC's) that otherwise result from industrial cleaning with organic solvents.

A variety of cleaning solvents are used by industry to remove contaminants such as adhesives, inks, paint, dirt, soil, oil, and grease. Parts, products, tools, machinery, equipment, vessels, floors, walls, and other work areas are cleared for a variety of reasons including housekeeping, safety, operability, and to avoid product contamination. Solvents are used in enormous volumes and a portion of evaporates during use, making cleaning fluids a major source of emissions of VOC. Data collected by EPA show nationwide usage of VOC solvent from only six industries is about 380,000 megagrams per year (Mg/yr) (410,000 tons per year [tons/yr]). Less comprehensive data from other sources suggest total VOC solvent usage for cleaning by all U.S. industry is more than 1 million tons each year.

On average, 25 percent or more of the solvent that was used for cleaning purposes by the six industries (automotive, electrical equipment, metal furniture, photographic supplies, packaging, and magnetic tape) used for the study was lost by spillage or evaporation. This value varied significantly among industries depending on the type of cleaning performed.

The study of the six industries initially tried to quantitatively evaluate sources of evaporative emissions of VOC from solvents used as cleaning agents. The plan was to 1) examine cleaning "activities" such as wiping, spraying, and dipping to identify the most efficient options and 2) quantify the potential emission reductions and associated costs if use of the more efficient were widely mandated. This approach was not successful because data to support the necessary level of detail simply was not available. As a result, the Agency was unable to identify baseline emission levels, emission reductions or costs associated with this approach.

Subsequently, information was requested from industry using a different strategy. This time, respondents were asked to provide usage and waste information for objects or processes that had been cleaned rather than on the cleaning "activity". Nearly 300 sets of data sets based on this new approach were collected from the six industries. The responses were closely studied; numerous calls were made to maximize understanding of the information.

The data indicated that all use of solvent for cleaning can be evaluated on the basis of one of only nine general types: cleaning of spray guns, spray booths, equipment, large manufactured components, small manufactured components, floors, tanks, lines and parts. Within each group, however, there is considerable variation, including differences in cleaning techniques, soils removed, solvency, and a likely host of others.

Figure 1-1 displays the relative emissions from the nine types of unit operation systems. Somewhat surprisingly, cleaning of spray guns accounted for 50 percent of the total emissions

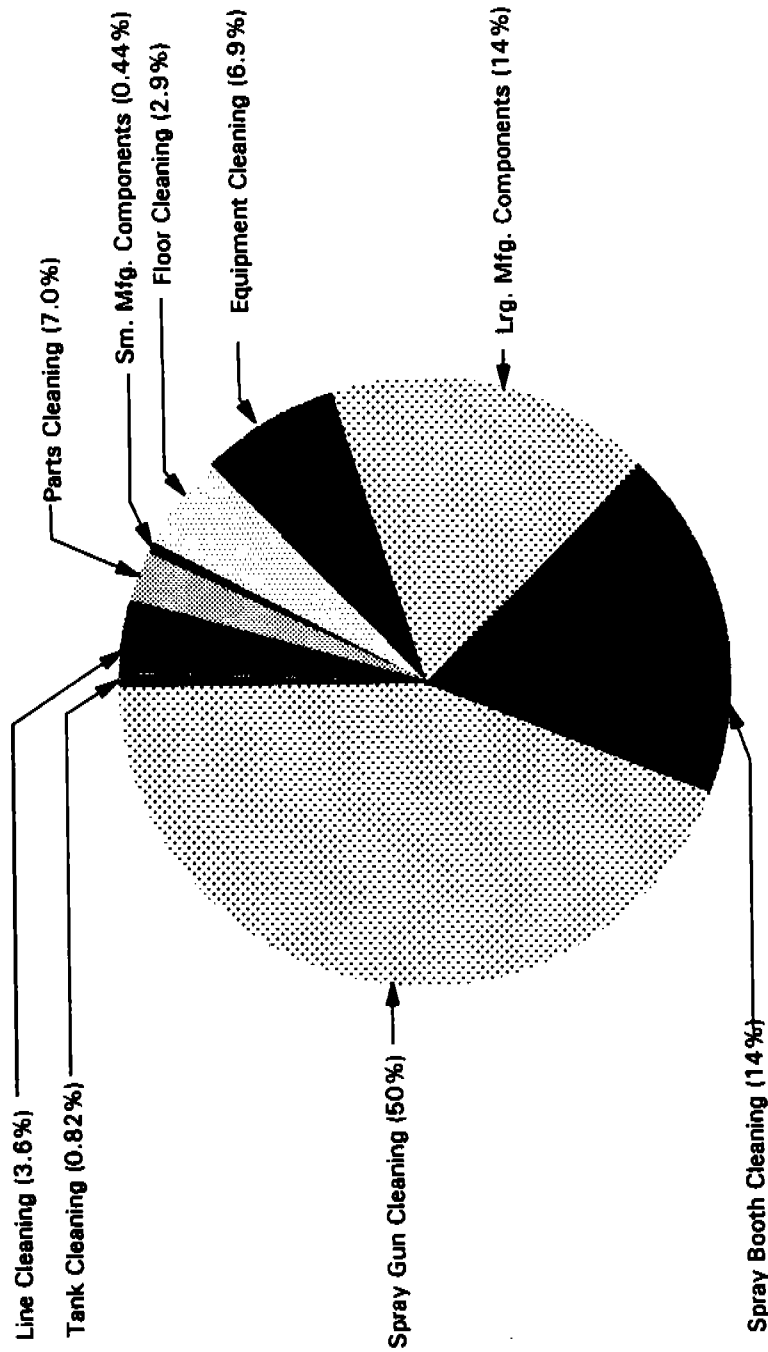

Figure 1-1. Distribution of nationwide emissions in the focus industries.

while most of the remaining were from wiping and spraying the exterior of various parts and equipment. Cleaning tanks and small manufactured components accounted for the least emissions. Equipment cleaning, the most common unit operation, produced only 7 percent of the total emissions.

Although this "unit operation system" approach generated more comprehensible information, the data were still of questionable accuracy for several reasons:

1. Most companies maintained only two types of records; solvents purchased and (as a result of hazardous waste rules) total contaminated solvent released for disposal as hazardous waste.

2. Of the total solvent purchased, only part is used for cleaning purposes; there was little or no information available to quantify how much.

3. Respondees attempted to estimate the desired information, but clearly the requisite details were not available.

4. Further, close review of the data that was submitted revealed that many of the numbers did not balance. The reason was that in many cases the usage estimates were based either on solvent inventories or "guesstimates." Also most plants did not segregate their waste solvent or inadvertently overestimated the solvent in the waste stream by not subtracting the amount of contaminants.

5. There was a large variety in the quantities and ways solvents are used for cleaning, both among and within industries.

6. Communications were difficult and imprecise; all companies did not closely follow the instructions (and vocabulary) that accompanied the questionnaire.

Many industrial facilities' solvent costs, at present, are carried as a plantwide expense item with essentially no records of where or how the materials are used. For example, for accounting purposes, solvents are frequently charged as a plant inventory item (rather than charged against different business

centers within the plant). Further, access is often as simple as opening a valve. No accountability is required. Even at plants where the cost of cleaning solvents is charged to various business or cost centers within the plant, usually it is not on a relative usage basis. Instead, the total solvent cost may be assigned to the individual cost centers using some surrogate such as cash flow or number of employees.

Despite the difficulties listed above and general lack of detailed information on cleaning solvent use, the study revealed that a number of companies, for a variety of reasons, had found it in their best interests to reduce the amount of solvent used for cleaning. The reasons varied, cost of disposal of hazardous waste, the cost of solvent, employee exposure and state air pollution rules were factors. Often, a common factor was that management expressed interest and set priorities on learning where and how solvents and other chemicals were consumed. Management concern usually resulted in reduced usage. Simultaneously, reduced usage resulted in lower emissions and costs and also moderated the rate and cost of waste generation.

A key element then, to reducing emissions from use of cleaning solvents is to learn where and how solvents are used. As demonstrated by some plants in the study, this can be done by institution of a solvent accounting system that quantitatively records where cleaning solvent is used. The general consensus of plants that implemented a solvent accounting system is that the resulting benefits and cost savings from changes in cleaning practices or equipment outweigh the costs to implement and maintain the accounting system.

As an alternative to the initial plan to describe specific emission control techniques, this document describes a program that is based on the above findings. The program consists of two main elements; solvent accounting and plant management (or State agency) actions. "Accounting" consists of records of the usage, fate, and cost of cleaning solvents in each business center. While accounting, in and of itself, may not result in reductions,

it will identify and allow attention to be placed on the largest uses of solvent and sources of emissions.

Once data are available via the solvent accounting system, plant management and State agencies have a number of options for reducing solvent usage and emissions. The plant management will likely focus on actions that affect usage rates, while the State agencies will emphasize ways to reduce emissions. Example actions are listed in Table 1-1. One widely applicable action is to search for alternative cleaning materials that would release less VOC's to the atmosphere. Avenues for success include use of either aqueous cleaning fluids or organic cleaning solvents that evaporate more slowly.

Plants with many cleaning activities, or with many unit operations, in each cost center may find the cost center level is too large to allow identification of the major emission sources in order to initiate steps to reduce solvent emissions. In that case, data must be assembled on a more focused basis. A particularly helpful concept is to collect data on a "unit operation system" (UOS) basis¹. A UOS is defined in this study as an ensemble around which a material balance for cleaning can be performed. Such a material balance aids detailed quantitative evaluations of usage and emissions of solvent. The boundaries of a UOS should be selected to include all possible points/sources leading to evaporative emission losses associated with cleaning a specific unit operation, including losses during dispensing the solvent, spilling virgin and used solvent, handling residual solvent in cleaning applicators, etc. The UOS approach is described in Appendix C.

Detailed accounting of data on the input and output streams for a UOS should result in the best chance to identify areas with the greatest emission, usage, or waste reduction potential. The more specific and better defined the UOS, the better the analysis will be. Implementing the UOS approach or taking other actions like those on Table 1-1 will ultimately lead to implementation of emission reduction techniques.

TABLE 1-1. EXAMPLES OF SOLVENT MANAGEMENT ACTIONS

Plant management actions	State agency actions
1. Collect data on a UOS basis in cost centers where high costs have been identified.	1. Require plants to consider accounting on a UOS level if cost center data cannot be compared among plants.
2. Compare usage between two like cost centers or UOS's and require action by larger user.	2. Require plants to submit individual solvent reduction plans.
3. Provide incentives and goals to similar cost centers.	3. Compare solvent usage from like UOS's within a given industry and require justification from higher users.
4. Evaluate potential alternative cleaning solutions.	4. Mandate implementation of specific solvent management techniques.
5. Conduct experiments to determine minimum amount needed for each cleaning task.	5. Require plants to conduct extensive, short-term studies and to commit to take action based on results.
6. Implement an employee suggestion program.	6. Compile and share information on the use of cleaning solutions. Mandate use where appropriate.
7. Form a task force with other plant managers to compare cleaning practices.	7. Compile and share results of alternative cleaning solution tests. Mandate use where appropriate.

In short, the first step in reducing emissions from use of cleaning solvents is to identify those locations within the plant boundaries where the cleaning solvents are used--and lost--in the greatest quantity. This can be accomplished by requiring companies to institute accounting procedures to track the use and emissions from different places within the plant that use cleaning solvents.

The second step is to use the knowledge obtained from the accounting system. Specific actions may be initiated by plant management or specified by the State Agency. The accounting system provides a quantitative measure of the results of corrective actions and helps guard against subsequent regression to former working conditions.

The automobile industry has suggested an alternative approach (Appendix D), use of short term intensive studies to identify methods for reducing emissions from solvent use. This would obviously be a positive activity, worthy of encouragement by the State, and perhaps equally effective over the near term. Some subsequent tracking steps would appear necessary to assure that the initial success is not subsequently lost.

1. Memorandum from Wyatt, S ., EPA, to project file. February 24, 1994. "Unit Operation System" - Originator of Concept.

2.0 INTRODUCTION

Congress, in the Clean Air Act Amendments of 1990 (CAAA), supplemented previous mandates regarding control of ozone in nonattainment areas. A new Subpart 2 was added to Part D of Title I. Section 183(c) of the new Subpart 2 provides that:

...the Administrator shall issue technical documents which identify alternative controls for all categories of stationary sources of volatile organic compounds ... which emit, or have the potential to emit 25 tons per year or more of such air pollutant.

The Act further directs that these documents are to be subsequently revised and updated at intervals determined by the Administrator.

This is an alternative control techniques (ACT) document that discusses industrial cleaning solvents and provides technical information for State and local agencies to reduce VOC emissions. Detailed information was collected from surveys of 6 different U.S. industries, hereafter referred to collectively as "focus industries," and more general information from a variety of other sources. Data collected by EPA's surveys show nationwide usage from the six focus industries is about 380,000 megagrams per year (Mg/yr) (410,000 tons per year [tons/yr]). Less comprehensive data from other sources suggest total solvent usage for cleaning by all U.S. industry is more than 1 million tons each year.

The remainder of this report consists of three chapters and several appendices. Chapter 3 presents estimates of nationwide solvent usage and emissions. It also includes discussions of the

types of cleaning activities and the contaminants removed during cleaning.

Chapter 4 presents approaches to prevent cleaning solvent emissions through better solvent accounting and management activities. Alternative actions that States and plants can take to effect reductions are also discussed in Chapter 4.

Chapter 5 presents incremental costs for the accounting procedures and reduction techniques adopted by those plants that served as case studies. It also presents the estimated cost impact (as reported by one plant) of switching the method of cleaning paint spray guns from manual cleaning procedures to a machine designed for cleaning such equipment (a gun washer).

The appendices present definitions of terms, a summary of State and local regulations, a method for estimating fugitive emissions, a different alternative for achieving reductions in solvent usage, solvent accounting case studies, a method for evaluating alternative cleaning fluids, a method for determining emissions from spray gun cleaning, and a spray gun cleaning case study.

3.0 INDUSTRIAL CLEANING WITH ORGANIC SOLVENTS

A variety of organic solvents are used in enormous volumes as cleaning fluids by industry. A portion of all solvents evaporate during use, making cleaning fluids a major source of emissions of volatile organic compounds (VOC's). This report describes alternative techniques that will reduce VOC emissions from those industrial cleaning solvents used to remove contaminants such as adhesives, inks, paint, dirt, soil, oil, and grease. (Vapor degreasers and conveyORIZED, batch-loaded, and remote reservoir cold cleaners, when used for cleaning metal parts, were not addressed in this study, but are addressed in another report titled "Control of Volatile Organic Emissions from Solvent Metal Cleaning," EPA-450/2-77-022, November 1977.) Contaminants must be periodically removed from parts, products, tools, machinery, equipment, vessels, floors, walls, and other work areas for a variety of reasons including safety, operability, and to avoid product contamination.

This chapter, the product of an extensive study of cleaning activities in a wide and diverse assortment of industrial facilities, presents an overview of how organic solvents are used by industry for cleaning. It discusses the industries that use cleaning solvents, the kinds of solvents used, the type of cleaning activities performed, and current practices, or lack there of, for managing the use of solvents.

Further, the chapter describes the material balance concept used for soliciting information and quantifying emissions. It also describes the nine categories of "unit operation systems" (UOS's) into which all types of industrial cleaning were grouped.

3.1 OVERVIEW OF CLEANING

This section presents an overview of the cleaning process. First, four mechanisms by which contaminants are removed are described. Also presented are discussions of cleaning "activities" (i.e., dipping, flushing, purging, spraying, and wiping) and factors, including the degree of cleanliness demanded, that affect emissions.

3.1.1 Cleaning Mechanisms

The cleaning activities that use organic solvents to remove contaminants used by industry rely on one or more of the following four mechanisms.

3.1.1.1 Solubilization. The contaminant must dissolve in the cleaning solvent which may be either a neat solvent or solvent mixture.

3.1.1.2 Surface Action. The (nonmechanical) displacement of the contaminant from the surface that is cleaned through changes in surface tension. Surface action can be achieved by a detergent or through emulsification of the contaminant.

For example, a detergent displaces a contaminant with its surface-active agent or surfactant. Because surfactants exhibit greater affinity to the surface than do the contaminants, the latter are displaced by surface phenomenon, the lowering of surface and interfacial tension.

Emulsification refers to the effect of the contaminant and the cleaning medium on each other. In the presence of an emulsifier, portions of the contaminant (e.g., oil) are coated with a thin film of the cleaning solvent, which prevents rebonding of the contaminant to itself or to the surface. The coated contaminant particles remain suspended in the cleaning medium.

3.1.1.3 Mechanical Action. The contaminant is physically displaced by mechanical agitation (e.g., brushing). Solvents are used to increase the efficiency of the mechanical action via solubilization or surface action.

3.1.1.4 Chemical Reaction. A material is added that reacts with the contaminant to form a soluble product, allowing the contaminant to be flushed away.

3.1.2 Description of Cleaning Activities

This section discusses dipping, flushing, purging, spraying, and wiping actions that have been deemed "cleaning activities." Each activity is discussed independently. In many cases, however, combinations of these activities may be used to meet the cleaning needs.

3.1.2.1 Dipping. Dipping involves immersing an item into a container of solvent to remove contaminants or residue. For purposes of this study, a dipping activity is an operation where the operator manually places the items to be cleaned into the solvent and also removes them. The objects being cleaned simply soak (partially or completely) in a solvent bath, contained in any of various-sized containers. The mechanism of contaminant removal is based on the solubility of contaminant in the solvent. Agitating the solvent by mechanical means (e.g., stirring) increases the rate of removal of the contaminants from the substrate but also increases evaporation.

Dipping is widely used for maintenance or tool cleaning during the manufacturing process. Dipping may be used to clean both the exterior and interior of the item. The container may have a lid to reduce solvent evaporation and splashing, as well as a mesh basket to allow convenient loading and unloading of parts.

The solvent used for a dipping activity is usually at ambient temperature. It may be stirred to speed the cleaning process or to improve cleaning efficiency. Spent solvent from this cleaning activity should be collected and recycled, reused, or disposed of as hazardous waste.

Three major sources of emissions are associated with dipping. The first is evaporation during the soak. The absence of a lid during soaking may also contribute to additional emissions by allowing solvent to splash out during any associated agitation.

The second major source is "dragout": evaporation of the cleaning solvent carried out of the container in recesses or the interior of the objects being cleaned.

The third source of emissions is associated with the handling of the spent solvent. If kept in an uncovered vessel, significant evaporation may take place. Even if the cover is well gasketed, some evaporative emissions may occur.

3.1.2.2 Flushing. Flushing involves pumping solvent from a reservoir through a pipe or hose onto or through equipment (e.g., pipes, hoses, tanks) to remove contaminants or residue.

During flushing, the solvent is moved through the object being cleaned. Flushing is frequently used for maintenance cleaning of the interior of objects or in conjunction with other manufacturing processes. Reservoirs or piping may be cleaned prior to storage of new materials (e.g., tank flushing). Process vessels (e.g., reactors) may be flushed between batches.

In general, flushing requires solvent, a storage tank, a hose, piping, and a spent solvent container. To flush an object, portable equipment may be used. The solvent is pumped from its reservoir through a hose onto or through the object being cleaned. In some cases, the solvent may be used on a once-through basis, discharged directly into a container (e.g., a waste solvent drum), and reused elsewhere in the plant, recycled, or disposed of as hazardous waste (We presume that operations no longer intentionally allow spent solvent to evaporate in order to reduce hazardous waste disposal costs.) In other cases, the solvent may circulate back to the feed reservoir for reuse the next time cleaning is required.

Once the solvent becomes so contaminated that it no longer performs satisfactorily, the entire contents of the reservoir may be transferred to another container to await recycling within the plant or disposal as hazardous waste. More elaborate (and usually fixed) systems are designed to flush large equipment (e.g., a reactor vessel) at the end of a batch or for periodic maintenance. In this case, the solvent may be delivered through built-in piping.

Flushing dissolves or disperses the contaminants in the solvent. A contributing factor is agitation, which results from the force or pressure exerted by the cleaning solvent stream from the piping.

Emissions from this cleaning activity are minimal provided that the system does not leak. However, the quantity of fugitive emissions and the number of emission points can vary depending on the object being cleaned and the technique used for flushing. Depending on their construction, emissions can also be associated with the storage tanks for virgin and spent solvent if they are open or loosely lidded and with the process line while being cleaned.

3.1.2.3 Purging. Purging is similar to flushing, but in this report it applies only to cleaning the interior of spray guns and other attached equipment (e.g., hoses, paint cups) cleaned simultaneously with the spray gun. Spray guns are used primarily to apply paints, other coatings (e.g., resin or wax), and oil to manufactured products. Typically, spray guns are cleaned periodically during operation and at the end of production shifts to prevent plugging. Paint spray guns must also be cleaned in preparation for a color change.

Spray guns are purged by a variety of techniques. For example, siphon-feed paint spray guns with attached paint cups are cleaned manually by adding solvent to the cup and pulling the trigger to force solvent through the gun and nozzle. Pressure-feed guns with variable lengths of hose also may be cleaned manually. Purge solvent in these cases may be used on a once-through basis or recirculated. Once-through solvent is sometimes sprayed directly into the air where it all evaporates; other plants direct the spent solvent to a collection vessel for disposal or reuse.

Plants that perform a lot of painting often have robotic spray systems that can recirculate paint and/or cleaning solvent. These systems are cleaned automatically by solvent that is delivered through permanent (and dedicated) fixed piping. Additional fixed piping attached to the base of the gun also

either directs most of the used solvent to a spent solvent storage tank or recirculates it back to the feed tank. Some robotic or reciprocal equipment have integral recovery systems that preclude the release of any liquid solvent into the air. Others permit only the briefest burst of solvent through the gun tube and nozzle into the air; where it evaporates.

The pressure exerted by the solvent pushes the bulk of the paint or other contaminant through the line and gun in semi plug flow. Some contaminants are dissolved in the solvent.

In addition to evaporation of some or all of the solvent discharged into the air, emissions may also occur from virgin and spent solvent storage vessels and leaks from fittings in the solvent and paint lines.

3.1.2.4 Spraying. Spraying involves applying cleaning solvent to a surface through a nozzle so that the solvent's energy of momentum is converted to mechanical pressure as it impacts the part to be cleaned. It can be used for cleaning outer or inner surfaces of objects (e.g., the inside or outside of a tank).

Spraying parts with cleaning solvent saves labor, time, and money compared to other cleaning activities such as wiping. Spraying can quickly wet many parts with solvent. Wiping requires that a worker wet each surface one at a time. Thus the labor costs of spraying can be several times lower than the costs of other cleaning activities. However, the equipment costs for spraying are somewhat higher.

Spray cleaning systems can be either automated or manual. Automated systems are typically fixed in one location (e.g., a spray booth), while manual systems can either be fixed or portable. Automated systems tend to be larger and more complex. They may include a solvent reservoir to hold virgin solvent, piping, a pump, spray arms, nozzles, a basket to hold the parts (for a cold cleaner), and a container to collect spent solvent. Manually activated spray systems consist of a fixed or portable reservoir of virgin solvent connected to a pump system and then

to a hose and nozzle. Portable solvent reservoirs hold several gallons of solvent, while fixed storage tanks are much larger.

Solubilization is the primary mechanism for contaminant removal in spray cleaning. It occurs when an object (e.g., process equipment) is completely wetted by solvent that dissolves the contaminant. The impact of pressurized solvent (i.e., a mechanical action) can also dislodge contaminants, although only those that adhere loosely to the surface to be cleaned.

Emission points from spraying activities include (1) the surface of the object being cleaned (e.g., paint spray booth walls), (2) the virgin and spent solvent vessels if they are open or loosely lidded, and (3) the spray equipment itself. The emissions from the object being cleaned account for a varying portion of the total emissions. For example, evaporative emissions from wetting a small part are small compared to those from cleaning a large object such as the walls of a spray booth. Factors affecting the relative importance of these emission points are the vapor pressure of the solvent, the period of time the solvent is exposed to the air, and the ambient temperature.

3.1.2.5 Wiping. Wiping is a simple form of solvent cleaning and relies on the solubility of the contaminant in the solvent or the surface action of the solvent plus the mechanical loosening of the contaminant from the substrate by rubbing. The absorbent wiper (e.g., rag, mop, or sponge) absorbs the solvent and transfers it to the substrate surface. Contaminant particles dissolve in the solvent, are loosened by surface action, or are dislodged by applied pressure. Dissolved contaminants are absorbed by the rag, while the loosened and dislodged particles either adhere to the rag or are pushed off of the object being cleaned. Wiping steps are repeated until the object is sufficiently clean. If the dirty rag, mop, or sponge is rinsed in the virgin solvent reservoir or the reclaimed solvent container, some of the contaminant will be transferred to the solvent in the reservoir. If not, the contaminant generally remains on the rag.

Wiping is perhaps the most common cleaning activity:

(1) the contaminant often is more quickly removed because of the associated mechanical energy used and (2) it is a mobile activity easily performed anywhere in the plant. Little equipment is needed. The only costs accrued are for labor and materials; there is no capital cost. This cleaning activity is most appropriate for maintenance (e.g., cleaning [machinery, floors, etc.] in place without disassembly or cleaning large pieces produced in small quantities that would be impractical to clean by alternative methods).

The major sources of emissions from wiping activities are evaporation from vessels that contain fresh and spent solvent, the solvent-soaked rags or other tools used, and spillage from containers. Evaporation of residual solvent from cleaned parts also contributes to emissions.

3.1.3 Factors that Affect Emissions

During cleaning, several factors contribute to the emissions of solvent. These can be divided into two categories: (1) those associated with the cleaning practice, and (2) those related to the physical or chemical properties of the solvent.

Higher evaporative emissions may result from careless or improper handling of cleaning tools (e.g., rags, brushes) or the part during and after cleaning. Another practice that increases solvent emissions is splashing and spillage during handling. Factors that increase emissions associated with the cleaning method itself include drying the tools or cleaned parts in areas ventilated directly to the atmosphere, not using covers (or using ineffective covers) for both the fresh and waste cleaning solvent, and using adsorbent or porous items (e.g., ropes, bags) for handling the solvent-wetted items.

The second category of factors that contribute to evaporative losses relates to chemical and physical properties of the solvents. Chemical factors include solvent volatility, viscosity, and any change in chemical properties caused by introducing the contaminant into the solvent, such as an increase or decrease in boiling point, surface tension, etc. Physical

factors are mainly associated with the air movement in the cleaning area and the ambient and process temperatures, all of which can contribute to increases in evaporation rates.

Still another physical factor is the degree of cleanliness demanded, that is, the specification for contaminant removal that must be met. There is no common standard of measurement, and "clean" varies depending on the application and the industry. Three general categories of cleanliness are:

1. Cleaning as a step in the manufacture of products.

The primary reason for this type of cleaning is to prepare an object for a subsequent manufacturing step, such as painting. As a result, complete removal of the residual cleaning materials or solvents is typically required. An example is cleaning the surfaces of a newly manufactured part (e.g., metal furniture) prior to painting or initiating another coating operation, where a high standard of cleanliness is necessary to ensure proper adhesion of the coating. Still another example is use of solvent to remove mold release compounds from molded plastic products (such as a fiberglass boat prior to painting the hull) or to remove all miscellaneous contaminants from a primed car body prior to topcoating.

In selecting the solvent for cleaning products during manufacture, performance is the critical test. The solvent must achieve the desired cleaning in a way that permits the product to be manufactured competitively. The cost of the solvent is relatively minor compared to the labor and cost of rework should the coating fail (or some other problem occur) as a result of insufficient cleaning. In selecting a cleaning material or considering a change, one must be mindful that residues of cleaning materials may be unacceptable. The only acceptable cleaner may be an organic solvent.

2. Cleaning of process equipment. This cleaning is often done to prevent cross-contamination between different batches of material prepared using the same equipment. An example is cleaning paint manufacturing tanks between production of batches of different colors. Another is purging coating application

spray guns and associated lines and hoses with solvent prior to a color change or at the end of the day's operations.

The cleaning requirement for process equipment may be fairly rigorous to preclude contamination that would spoil the next batch or next product (e.g., car). The solvent selected for cleaning is often the same solvent used in the manufacturing operation to avoid a compatibility problem.

3. Cleaning before maintenance. Parts and equipment may need cleaning prior to or during maintenance operations. Cost and convenience are important concerns affecting solvent selection. The level of cleanliness may be less important. Cleaning may be conducted for convenience--to remove grease, for example--rather than to meet more specific requirements. In other maintenance circumstances, the cleaning requirements may be very high.

3.2 INDUSTRIES THAT USE VOC SOLVENTS FOR CLEANING

This section presents a quantitative overview of cleaning solvent use by industry and a discussion of cleaning solvent accounting/tracking practices.

3.2.1 Quantitative Overview of Cleaning Solvents Use

Cleaning activities are an inherent and essential step of any production process. Solvents are used extensively for this purpose by many industries. Table 3-1 lists 13 industries known to so use organic solvents and presents estimates of nationwide use in each industry. (Corresponding metric values are shown in Table 3-2.) These tables reveal that the total usage for those industries are somewhere between 270 and 1,400 tons/yr (240 and 1,300 Mg/yr). This is a low estimate of total nationwide use because many other industries are known to also clean with organic solvents.

Estimates were obtained from five sources. Four are previous studies by the Agency that reported the nationwide use of organic solvents for all purposes by certain industries.¹⁻⁴ The fifth source is the current study.⁵ Tables 3-1 and 3-2 are based on information from the first four and a ratio of cleaning solvent to total solvent usage developed during the current

TABLE 3-1. ESTIMATES OF THE AMOUNT OF VOC CLEANING SOLVENT USED BY INDUSTRY, x 10³ tons/yr

Industry	Reference						Low	High
	1	2	3	4	5			
Automotive--manufacturing (3711)	89-410 ^a				72		72	410
Automotive--trucks and buses (3713)					16		16	16
Automotive--parts/access. (3714)					7.7		7.7	7.7
Automotive--stamping (3465)					1.0		1.0	1.0
Adhesives	73-330		46-210				46	330
Packaging					30		30	30
Plastics			28-130				28	130
Furniture	19-88				230		19	230
Rotogravure printing		14-62					14	62
FRP boats		8.3 ^b					8.3	8.3
Autobody refinishing	7.8-35		16-72	26-120			7.8	120
Electrical equipment					5.6		5.6	5.6
Magnetic tape		5.5 ^b			11		5.5	11
Photographic supplies (chemicals)		3.9 ^b			41		3.9	41
Offset lithographic printing		1.1-6.6 ^b					1.1	6.6
Total							270	1,400

^aThis range may represent usage in more than the 3711 SIC subcategory.
^bEstimate based on a usage = emissions assumption.

TABLE 3-2. ESTIMATES OF THE AMOUNT OF VOC CLEANING SOLVENT USED BY INDUSTRY, x 10³ Mg/Yr

Industry	Reference					Low	High
	1	2	3	4	5		
Automotive--manufacturing (3711)	81-370 ^a				65	65	370
Automotive--trucks and buses (3713)					15	15	15
Automotive--parts/access. (3714)					7.0	7.0	7.0
Automotive--stamping (3465)					0.9	0.9	0.9
Adhesives	67-300		42-190			42	300
Packaging					27	27	27
Plastics			25-120			25	120
Furniture	21-80				210	21	210
Rotogravure printing		12-56				12	56
FRP boats		7.5 ^b				7.5	7.5
Autobody refinishing	7.1-32		14-66	24-110		7.1	110
Electrical equipment					5.1	5.1	5.1
Magnetic tape		5.0 ^b			10	5.0	10
Photographic supplies (chemicals)		3.5 ^b			37	3.5	37
Offset lithographic printing		1.0-6.0 ^b				1.0	6.0
Total						240	1,300

^aThis range may represent usage in more than the 3711 SIC subcategory.

^bEstimate based on a usage = emissions assumption.

study. Table 3-3 summarizes the number of facilities and number of data sets obtained from the six focus industries in the current study. Data were gathered through information requests designed to obtain a variety of information on cleaning practices, including the type and volume of solvents used. Cleaning solvent usage and emissions in the six industries are discussed further in Section 3.2.3.

TABLE 3-3. AGENCY DATA GATHERING EFFORT

Industry	No. of facilities	No. of data sets ^a
Automotive--Manufacturing (3711)	8	78
Automotive--Trucks/buses (3713)	1	7
Automotive--Parts/access. (3714)	4	18
Automotive--Stamping (3465)	2	6
Electrical equipment	8	63
Magnetic tape	3	14
Furniture	6	87
Packaging	1	6
Photographic supplies (chemicals)	1	14
TOTAL	34	293

^aA data set is all the data gathered that pertained to the cleaning of one industrial unit operation or several similar unit operations, depending on how each facility reported data.

Cleaning solvent usage makes up 9 to 41 percent of total solvent usage, based on data from seven of the plants surveyed for this study.⁶ They were the only plants (four in the electrical equipment, and one each in the furniture, packaging, and photographic supplies industries) that provided sufficient data to calculate the ratio. This 4-fold range was used to calculate nationwide usage values for References 1 through 4 in Tables 3-1 and 3-2.

The 4-fold range was also used to estimate a lower bound of national cleaning solvent usage in all industry. These resulting values are believed low because they are based on sales of only 19 solvents; others may also be used as cleaners. Table 3-4 lists frequently used cleaning solvents at the plants in the focus industries. Only solvents used at three or more plants (as either a single compound or as a component of a mixture) are included in the table.⁷ Total annual U.S. sales of these same solvents are compiled in Table 3-5.⁸ Applying the cleaning-to-total solvent usage ratio to these sales resulted in an estimated national cleaning solvent usage of 1.3 to 5.7 million tons/yr (1.2 to 5.3 million Mg/yr).

Data from nine automotive assembly plants reveal cleaning solvent emissions ranging from 22 to 61 percent of the total emissions.⁶ (However, one furniture manufacturer reported cleaning emissions to be only 1 percent of the total.) Although the usage (9 to 41 percent) and emission (22 to 61 percent) ratios were based on data from plants in separate industries, conclusions can be drawn from the differences. The differences suggest that a plant cannot use a known usage ratio as an accurate approximation of an unknown emissions ratio. This result is to be expected, considering emissions from production uses of solvent are independent of emissions from cleaning uses. For example, a portion of cleaning solvent may be collected and reclaimed, while all production solvent may be used as a paint thinner and ultimately emitted either during manufacturing or later use of the paint.

3.2.2 Accounting/Tracking Procedures

The EPA's study also revealed that many industrial facilities carry the cost of solvents as a plantwide expense item with essentially no records of where or how the materials are used. For example, for accounting purposes, solvents are frequently charged as a plant inventory item (rather than charged against different profit centers within the plant). Further, access is often as simple as opening a valve. No accountability is required. Even at plants where the cost of cleaning solvents

TABLE 3-4. FREQUENTLY USED INDUSTRIAL CLEANING SOLVENTS⁷

Solvent name	Hazardous air pollutant ^a	Solvent occurrences		Solvent concentration in compound formulation, %
		As pure solvent	As part of compound formulation	
Acetone	No	5	8	11-57
Alcohols ^b	c	2	1	--
Butyl acetate	No	1	5	12-38
Cyclohexanone	No	4	--	--
Ethanol	No	13	5	49-95
Ethyl acetate	No	6	4	2-50
Ethyl benzene	Yes	--	6	1-20
Ethylene glycol	Yes	--	3	5-10
Isopropyl alcohol	No	9	8	9-35
Methanol	Yes	--	6	3-20
Methyl ethyl ketone	Yes	16	4	3-75
Methyl isobutyl ketone	Yes	1	9	2-50
Naphtha ^d	e	10	13	6-98
Perchloroethylene	Yes	--	3	1-36
Toluene	Yes	6	11	1-51
Xylene	Yes	12	19	1-83

^aSee Appendix A for the definition of a hazardous air pollutant (HAP). Those compounds that are HAP's are subject to regulation under Section 112 of the Clean Air Act.

^bTotal nonspecified production of C₁₁ or lower unmixed alcohols.

^cUnknown whether this class includes HAP's.

^dThis solvent includes naphthas, petroleum naphtha, VM&P naphtha, mineral spirits, stodard solvents, naphthols, and naphthanols.

^eNaphthas may include HAP's.

TABLE 3-5. VOLUME OF SALES FOR COMMON CLEANING SOLVENTS⁸

Solvent name	Total U.S. sales for 1990, Mg/yr	Total U.S. sales for 1990, tons/yr
Acetone	760,000	840,000
Alcohols ^a	4,100,000	4,500,000
Butyl acetate	930,000	100,000
Cyclohexanone	51,000	57,000
Ethanol	280,000	330,000
Ethyl acetate	110,000	130,000
Ethyl benzene	470,000	510,000
Ethylene glycol	230,000	250,000
Isopropyl alcohol	560,000	620,000
Methanol	2,400,000	2,600,000
Methyl ethyl ketone	240,000	260,000
Methyl isobutyl ketone	49,000	54,000
Naphtha	b	b
Perchloroethylene	170,000	180,000
Toluene	1,600,000	1,700,000
Xylene	1,300,000	1,500,000
TOTAL	13,000,000	14,000,000

^aTotal nonspecified production of C₁₁ or lower unmixed alcohols.

^bFigure unavailable.

is charged to various business or cost centers within the plant, usually it is not on a relative usage basis. Instead, the total solvent cost may be assigned to the individual cost centers using some surrogate such as cash flow or number of employees.

Only one response indicated that the amount of solvent used for cleaning is actually measured, and then only for the solvent added or removed from a parts washing dip tank. Most facilities responded that they record only the total amount of solvent purchased and disposed. The amount purchased is available from purchase orders, and disposal information is maintained in Resource Conservation and Recovery Act manifests, biannual reports, and Treatment, Storage, and Disposal Facilities disposal records. Regulatory requirements were cited as the primary reason for existing recordkeeping practices. In some larger facilities, some form of recordkeeping is mandated by corporate requirements.

Part of the reason for such imprecise accounting is historical, but another is the cost associated with a more quantitative tracking system. In many automobile manufacturing plants, for example, a solvent line (pipe) makes solvent available to every painter or cleaning employee in a spray booth.⁹ At the turn of a valve, the employee has access to an unlimited supply of solvent. To quantify the usage by booth, employee, or other plant segment would require an investment in both meters and labor to enter the results into a plant accounting system.

3.2.3 Cleaning Solvent Use and Emissions in the Focus Industries

Cleaning with solvents in an industrial setting may be perceived on a unit-operation (UO) basis. The conventional unit operation, a term common to the chemical engineering discipline, is an industrial operation classified or grouped according to its function in an operating environment. Unit operations vary considerably among industries.

Data were solicited during this study from the six focus industries based on a material balance around a unit operation system (UOS). The concept of the unit operation "system" extends

the boundaries of the conventional "unit operation." The UOS is defined as the ensemble around which a material balance for cleaning can be performed. The boundaries of a UOS should be selected to include all possible points/sources leading to evaporative emission losses associated with cleaning a specific unit operation, including losses during dispensing the solvent, spilling virgin and used solvent, handling residual solvent in cleaning applicators, etc.

Nine types of UOS's were identified in this study that are believed to be representative of most solvent cleaning performed by all industry. These are: spray gun cleaning, spray booth cleaning, large manufactured parts cleaning, equipment cleaning, floor cleaning, line cleaning, parts cleaning, tank cleaning, and small manufactured parts cleaning. A detailed explanation of UOS can be found in Appendix C.

3.2.3.1 Distribution of UOS's at Surveyed Plants.

Table 3-6 presents the relative numbers of each UOS received in response to the Agency's information request. Data on a total of 293 UOS's were provided by industry. The equipment cleaning UOS was the most common, 28 percent, and parts cleaning was second at 23 percent. Only one industry, automotive, reported all nine types of UOS. The automotive industry submitted 38 percent of the total entries, while three, automotive, electrical equipment, and furniture, submitted 90 percent of the total.¹⁰

Equipment and parts cleaning were performed by all focus industries. Large manufactured components cleaning (i.e., the cleaning of large components during manufacture) and line cleaning each appear in only two (large manufactured components cleaning was reported by the automotive and furniture industries, while line cleaning was reported by the automotive and magnetic tape industries). Spray booth cleaning was reported only by the automotive industry. Table 3-7 details the types of UOS's reported by each focus industry.

TABLE 3-6. FREQUENCY OF UNIT OPERATION SYSTEM OCCURRENCE

Focus industry	Distribution of unit operation systems, percent										Total
	Equipment cleaning	Floor cleaning	Large manufactured components cleaning	Line cleaning	Parts cleaning	Small manufactured components cleaning	Spray booth cleaning	Spray gun cleaning	Tank cleaning	Total	
Automotive-manufacturing (3711)	2.4	1.4	7.9	2.4	0.34	1.4	3.8	5.1	2.1	27	
Automotive-trucks/buses (3713)	--	--	1.4	--	--	--	--	1.0	--	2.4	
Automotive-parts/access. (3714)	.68	--	--	--	3.8	--	--	1.7	--	6.1	
Automotive-stamping (3465)	--	--	--	--	1.7	0.34	--	--	--	2.1	
Electrical equipment	7.5	1.7	--	--	6.1	4.4	--	1.7	--	22	
Furniture	12	--	2.7	--	8.5	4.4	--	2.4	--	30	
Magnetic tape	1.4	--	--	0.34	1.4	--	--	--	1.7	4.8	
Packaging	1.0	0.34	--	--	.68	--	--	--	--	2.1	
Photographic supplies (chemicals)	3.1	0.34	--	--	0.34	--	--	0.34	.68	4.8	
Total	28	3.8	12	2.7	23	11	3.8	12	4.4	100	

TABLE 3-7. UNIT OPERATION SYSTEMS REPORTED BY THE FOCUS INDUSTRIES

Industry	Unit operation system
Automotive - manufacturing (3711)	Equipment cleaning Floor cleaning Large manufactured components Line cleaning Small manufactured components Spray booth cleaning Spray gun cleaning Tank cleaning
Automotive - Trucks/buses (3713)	Large manufactured components Spray gun cleaning
Automotive - Parts/access. (3714)	Equipment cleaning Parts cleaning Spray gun cleaning
Automotive - Stamping (3465)	Parts cleaning Small manufactured components
Electrical components	Equipment cleaning Floor cleaning Parts cleaning Small manufactured components Spray gun cleaning
Furniture	Equipment cleaning Large manufactured components Parts cleaning Small manufactured components Spray gun cleaning
Magnetic tape	Equipment cleaning Floor cleaning Line cleaning Parts cleaning Tank cleaning
Packaging	Equipment cleaning Floor cleaning Parts cleaning
Photographic supplies (chemicals)	Equipment cleaning Parts cleaning Spray gun cleaning Tank cleaning

3.2.3.2 Usage. Estimates of the nationwide amount of VOC-based solvents used in the focus industries are shown in Table 3-8. (Metric values are in Table 3-9.) These estimates were based on nationwide extrapolation of usage-per-employee factors for the surveyed plants (using total plant employment).⁵ Equipment cleaning, the most common UOS, consumes only about 3 percent of the cleaning solvent used in the focus industries. Spray gun cleaning, which constituted only 12 percent of the UOS's, consumes more than 50 percent of the solvent used.

3.2.3.3 Emissions. Nationwide emission estimates of VOC's from the nine UOS in the focus industries are presented in Table 3-10 (metric values are in Table 3-11.) These estimates, limited to the focus industries, are useful primarily for comparing emissions among the variety of systems. They were developed using the same procedure used to estimate the nationwide usage estimates. First, emission factors were developed for each UOS using emissions and plant employment data from the surveyed plants. These factors were then used with total employment figures for each industry to estimate the nationwide emissions.⁵

The tables indicate that spray gun cleaning is the largest emission source in the focus industries, while cleaning tanks and small manufactured components is the smallest. Figure 3-1 displays the relative emissions from the nine types of UOS's. Although spray gun cleaning constituted only 12 percent of the entries shown in Table 3-6, it is by far the largest source of emissions, 50 percent. Equipment cleaning, the most common UOS, produces only 7 percent of the total. The three highest-emitting systems, cleaning of spray guns, spray booths, and large manufactured components, account for 78 percent of the total emissions.

Cleaning of internal surfaces (spray guns, lines, tanks, and spray booths) accounts for nearly 70 percent of the total emissions. Cleaning of external surfaces (equipment, floor, large and small manufactured components) accounts for nearly

TABLE 3-8. NATIONWIDE VOC SOLVENT USAGE ESTIMATES FOR FOCUS INDUSTRIES (TONS/YR) a

Focus industry	Nationwide VOC solvent usage by unit operation system, tons/yr										Total ^b
	Equipment cleaning	Floor cleaning	Large manufactured components cleaning	Line cleaning	Parts cleaning	Small manufactured components cleaning	Spray booth cleaning	Spray gun cleaning	Tank cleaning		
Automotive - Manufacturing	220	570	8,400	14,000	129	180	17,000	28,000	3,100		72,000
- Trucks/buses			6,900					8,800			16,000
- Parts/access.	15				7,600			130			7,700
- Stamping					1,000	13					1,000
Electrical equipment	500	77			1,900	290		2,800			5,600
Furniture	7,300		900	39,000	1,800	130		180,000			230,000
Magnetic tape	670			330	2,400				7,700		11,000
Packaging	1,300	5,900			23,000						30,000
Photographic supplies	4,400	3.1			130			5.3	36,000		41,000
Total ^b	14,000	6,600	16,200	53,000	38,000	610	17,000	220,000	47,000		410,000

1 ton = 2,000 lb_m.

^aEstimates based on nationwide extrapolation of usage-per-employee factors from surveyed plants (using total plant employment).
^bTotals are different due to rounding.

TABLE 3-9. NATIONWIDE VOC SOLVENT USAGE ESTIMATES FOR FOCUS INDUSTRIES (MG/YR) ^a

Focus industry	Nationwide VOC solvent usage by unit operation system, Mg/yr										Total
	Equipment cleaning	Floor cleaning	Large manufactured components cleaning	Line cleaning	Parts cleaning	Small manufactured components cleaning	Spray booth cleaning	Spray gun cleaning	Tank cleaning		
Automotive - Manufacturing	200	520	7,600	13,000	120	160	16,000	26,000	2,800		65,000
- Trucks/buses			6,300					8,000			14,000
- Parts/access.	14				6,900			120			7,000
- Stamping					940	12					950
Electrical equipment	450	70			1,700	270		2,600			5,100
Furniture	6,400		810	36,000	1,500	110		170,000			210,000
Magnetic tape	600			300	2,200				7,000		10,000
Packaging	1,200	5,400			21,000						27,000
Photographic supplies	4,000	2.8			120			4.8	33,000		37,000
Total	13,000	5,900	15,000	49,000	34,000	540	16,000	200,000	43,000		380,000

¹ Mg = 10⁶ g

^aEstimates based on nationwide extrapolation of usage-per-employee factors from surveyed plants (using total plant employment).

TABLE 3-10. NATIONWIDE VOC EMISSION ESTIMATE FOR FOCUS INDUSTRIES, tons/yr

Focus industry	Emissions per unit operation system										Total ^a
	Equipment cleaning	Floor cleaning	Large manufactured component cleaning	Line cleaning	Parts cleaning	Small manufactured component cleaning	Spray booth cleaning	Spray gun cleaning	Tank cleaning		
Automotive-manufacturing (3711)	220	570	7,700	130	130	180	15,000	9,500	110		34,000
Automotive-trucks/buses (3713)			6,900					8,800			16,000
Automotive-parts/access. (3714)	15				2,100			55			2,200
Automotive-stamping (3465)					320	13					330
Electrical equipment	450	77			520	220		1,100			2,400
Furniture	5,600		840	3,800	540	72		36,000			47,000
Magnetic tape	230			6.6	440				430		1,100
Packaging	960	2,500			3,500						7,000
Photographic supplies (chemicals)	110	3.1			1.3			5.3	360		480
Total ^a	7,600	3,200	15,400	3,900	7,600	490	15,000	55,000	900		109,000

¹ 1 ton = 2,000 lb_m

^aTotals do not match due to rounding.

TABLE 3-11. NATIONWIDE VOC EMISSION ESTIMATE FOR FOCUS INDUSTRIES, Mg/yr

Focus industry	Emissions per unit operation system										Total ^a
	Equipment cleaning	Floor cleaning	Large manufacturing components cleaning	Line cleaning	Parts cleaning	Small manufacturing components cleaning	Spray booth cleaning	Spray gun cleaning	Tank cleaning		
Automotive-manufacturing (3711)	200	520	7,000	120	120	160	14,000	8,700	95		30,000
Automotive-trucks/buses (3713)			6,300					8,000			14,000
Automotive-parts/access. (3714)	14				1,900			50			2,000
Automotive-stamping (3465)					290	12					300
Electrical equipment	410	70			470	200		1,000			2,100
Furniture	5,100		760	3,400	490	65		32,000			42,000
Magnetic tape	210			6	400				390		1,000
Packaging	870	2,300			3,200						6,400
Photographic supplies (chemicals)	100	3			1			5	330		440
Total ^a	6,900	2,900	14,000	3,500	6,900	440	14,000	50,000	820		99,000

¹ Mg = 10⁶ g.

^aTotals are not equal due to rounding.

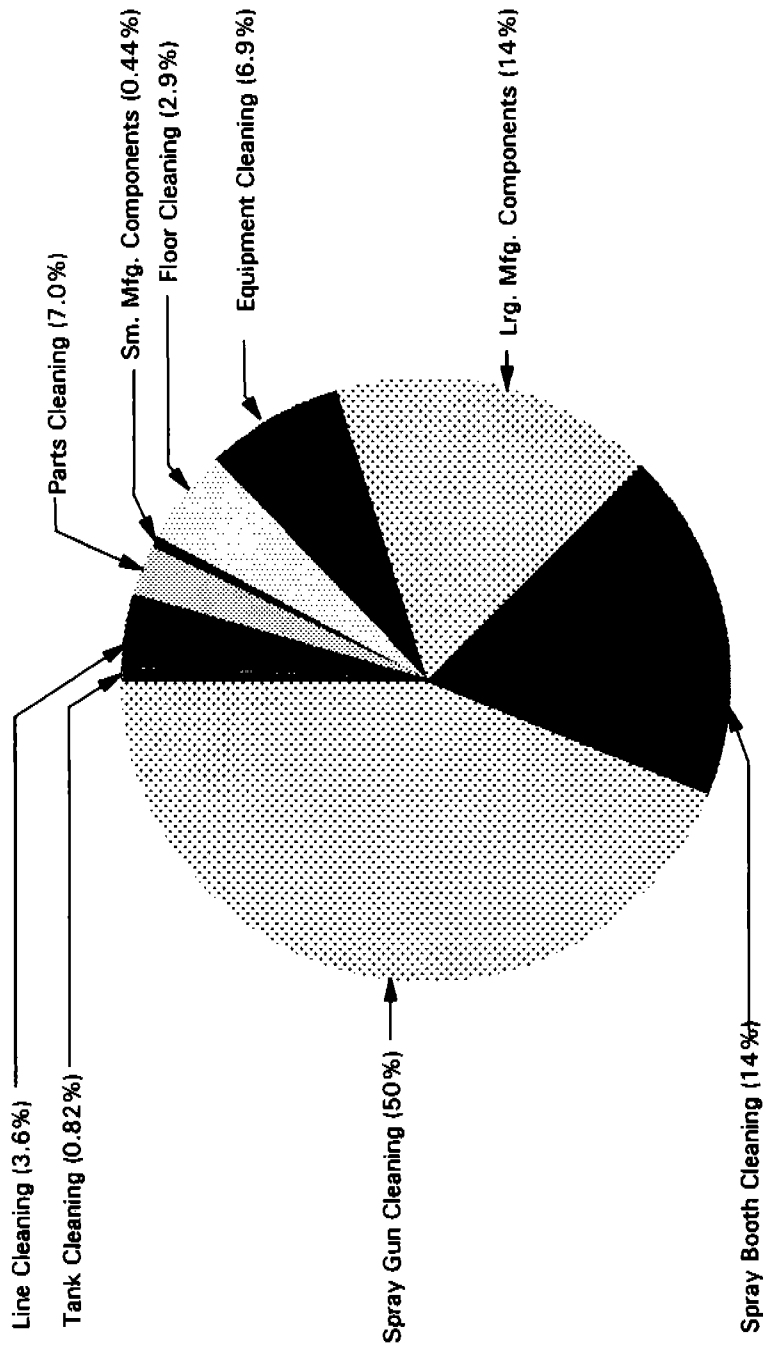

(NOTE: Emission estimates based on data for unit operation systems).
Figure 3-1. Distribution of nationwide emissions in the focus industries.

25 percent of the total emissions. Parts cleaning produces about 7 percent of the total emissions.

The percentage of solvent used that is lost through evaporation varies among the focus industries depending on the types of cleaning required. For example, the furniture industry, with a lot of spray gun cleaning that generates waste solvent, emitted about 20 percent of all cleaning solvent that it used. For the automotive assembly industry, which uses wiping activities as well as spray gun cleaning, the emissions were almost 50 percent of usage. Most of the other industries fell within this range.

Emissions are probably underestimated by most companies because values for the quantities of solvent in wastes are generally inflated. Many of the surveyed plants did not report and probably never account for contaminant concentrations in the waste solvent. Others merely estimated the values in response to a question of the Agency's survey, in the absence of analysis for VOC content of the waste. For spray gun cleaning, a similar underestimation occurs when plants do not account for paint in spraygun lines that is purged into a spent solvent tank during spraygun cleaning. This paint contains solvent as thinner, and plants do not account for this additional solvent.

3.3 REFERENCES FOR CHAPTER 3

1. Radian Corporation. Analysis of Solvent Consumption and End-Uses for Specific Chemicals. Draft Report. EPA Contract No. 69-02-4288. September 28, 1990. pp. 6.1-4.
2. Radian Corporation. Preliminary Review of 19 Source Categories of VOC Emissions. Final Report. EPA Contract No. 69-02-4378. May 20, 1988. pp. 19.2-6.
3. The Research Corporation of New England. End Uses of Solvent Containing Volatile Organic Compounds. Final Report. EPA Contract No. 68-02-4379. May 1979. Part I, p. 21.
4. Midwest Research Institute. Reduction of Volatile Organic Compound Emissions from Automobile Refinishing. CTC Report. EPA Contract No. 68-02-4379. October 1988. p. 6.

5. Memorandum from Schmidtke, K., MRI, to project file.
January 8, 1993. Calculations of Nationwide VOC Cleaning Solvent Usage and Emissions from Focus Industries.
6. Memorandum from Schmidtke, K., MRI, to project file.
July 2, 1993. Cleaning solvent as a percentage of total solvent usage and emissions at surveyed plants.
7. Memorandum from March, D., MRI, to project file. April 28, 1993. Summary of common cleaning solvents from the project data base.
8. U.S. Production and Sales 1990. In: Synthetic Organic Chemicals. U.S. Industry Trade Commission. Publication No. 2470. December 1991.
9. Telecon. Berry, J., EPA/CPB, with Mishra, R., General Motors Corporation. 1992. Program to reduce chemical use and costs.
1992.
10. Memorandum from March, D., MRI, to project file.
April 28, 1993. Number and frequency of unit operation system occurrences in data base.

4.0 SOLVENT ACCOUNTING AND MANAGEMENT SYSTEMS

Numerous VOC solvents are used for a multitude of industrial cleaning purposes. They are used to remove a variety of contaminants from many types of surfaces in all of the different unit operation systems (UOS's). This heterogeneity makes it difficult to identify "control techniques" that apply universally to all examples of one type of UOS (although it may be possible to develop such control techniques for a specific subcategory within one type of UOS, as discussed in Appendix H for spray gun cleaning).

Instead of specific control techniques, this chapter describes a program that is designed to reduce solvent usage, and allows plants wide latitude in selecting methods to achieve reductions. In this analysis, "usage" refers to the amount actually used in each cleaning activity. Thus, reducing usage also reduces emissions. Reuse and recycling of dirty solvent are not cleaning usage reduction techniques. They may reduce both the amount of solvent purchased and hazardous waste disposal, but they do not reduce the amount used for a cleaning activity.

Figure 4-1 outlines the program, which consists of two main elements: solvent accounting and solvent management. The first step toward reducing usage within a facility is to understand current solvent use practices, which is accomplished by establishing a solvent accounting system to track (i.e., measure and record) the use, fate, and cost of all cleaning solvents in the plant. The records would be developed at the cost center level at the plant. Such a tracking system, in and of itself, does not necessarily reduce solvent usage. It does, however, identify and allow attention to be focused on the largest points

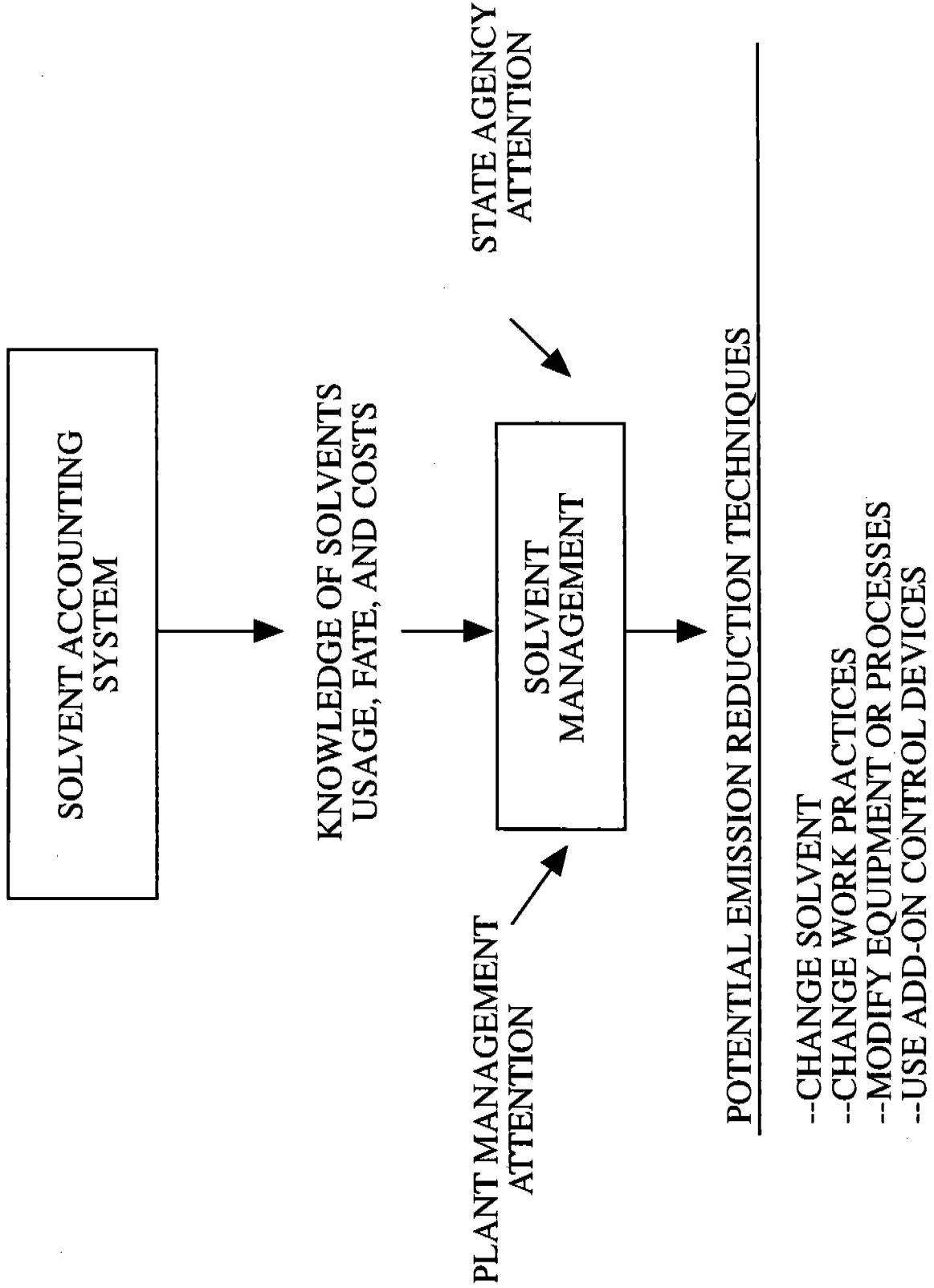

Figure 4-1. Controlling cleaning solvent usage.

of usage. It can set the stage for any of several subsequent activities that can have a profound impact on overall solvent consumption. Additional details about tracking procedures and options are presented in Section 4.1.

In the second phase of the program, plant managers and/or State agencies take action based on knowledge acquired via the solvent accounting system. Such actions include application of material balances around individual cleaning activities within the cost center to determine which have the highest emissions, evaluation of alternative cleaning solutions, and experimentation to determine the minimum amount of solvent needed for particular jobs. Ultimately, the knowledge and actions will result in the implementation of emission reduction techniques. Collectively, any combination of these or other actions is referred to as part of a "solvent management system." Additional information about possible plant management and State agency actions is presented in Section 4.2.

Emission reduction techniques can be grouped into two categories--those that reduce evaporation at the source (unit operation) and those that control emissions. Actions that may reduce emissions at the source include switching to a different cleaner, reducing usage rates, and increasing collection of used solvent. Reduced usage and increased collection may be accomplished by changing work practices, modifying equipment (e.g., tools used in cleaning, solvent storage vessels, solvent dispensers), or changing a process. After the release of emissions, the only way to reduce emissions is with containment or capture and use of an add-on air pollution control device.

Many plants that implemented a program similar to this have reported reduced cleaning solvent usage. Case studies are highlighted in Appendix E. Similar benefits were noted by researchers that reviewed the procedures many companies used to identify cost-effective source reduction programs in areas other than solvent cleaning. They found that plants with rigorous accounting procedures for both cost and materials implemented an average of three times as many pollution reduction techniques as

did plants with only rigorous accounting for materials. (All plants had materials accounting procedures.) Rigorous cost accounting procedures incorporate pollution costs and charge them against specific processes (i.e., unit operations) rather than to general overhead. Plant size was not a factor in a plant's ability to adopt accounting procedures. Both small and large plants implemented accounting systems and successfully identified reduction techniques. Most of the implemented reduction techniques were cost effective, about 75 percent with payback periods of less than 1 year.¹

The researchers also determined that other features of successful reduction programs include employee involvement and full managerial participation. Endorsement by both plant and environmental management has also proven to be integral to the success of reduction programs. Plants adopting these features implemented an average of twice as many reduction techniques as plants that failed to secure employee involvement and full managerial participation.¹ These concepts can also be used to reduce cleaning solvent usage. For example, operators and production personnel understand specific cleaning needs well, and soliciting suggestions from and involving them in reduction programs can provide a source of valuable information in identifying possible areas for attention.

4.1 SOLVENT ACCOUNTING

As noted in Section 3.2.2, the Agency's investigation into the use of solvent for cleaning revealed that for accounting purposes, solvents traditionally have been considered a plant "supply" or overhead item. That is, their use is so ubiquitous within a plant that the cost may be borne as a simple line item that is paid as overhead or is allocated across an entire plant or among the various internal cost centers on some artificial basis. Consequently, only the total amount of each solvent purchased and the total waste disposal shipments are a matter of record. This traditional process provides no real measure or paper trail of the relative usage by different segments of the plant. It provides no incentive (and perhaps significant

disincentives) to the individual cost center managers to conserve solvents (if everyone is paying, no one feels ownership). At best, such accounting procedures could lead to wasteful use because the charges to a specific cost (business) center are either zero or merely an artificially prorated portion of the incremental cost of wasted material.

The first step in problem solving is to define the problem. In the case of solvent usage, the Agency has concluded that successful "source reduction," or pollution-prevention, programs for reducing usage are possible only when management has more knowledge about use, fate, and associated costs (purchase and disposal) than presently exists in most American industries. The first step towards acquiring this knowledge is instituting a tracking program that enables the plant personnel to identify and quantify these parameters. Management interest should then focus where large quantities of the solvent are used (and emitted).

An avenue to increasing management awareness is to debit each cost center within the plant for the actual purchase and disposal costs associated with its use of solvent. The accounting systems can most easily be established within existing cost centers at a plant where other plant charges such as raw materials and utilities are already cumulated in periodic reports. There are advantages, however, to narrowing the focus even further to track data at the cleaning activity level within the cost centers because it identifies exactly where high solvent use and thus, cost occurs.

The accounting system generates line entries on the monthly cost sheet for each cost center that show the actual usage and waste disposal costs. To generate this information, all solvent inputs to and outputs from the cost center must be measured and recorded. Inputs include both virgin cleaning solvent and spent solvent from other processes that is used for cleaning. Outputs include the amounts of solvent collected for recycling, reclamation, and disposal. To be useful, the VOC portion of each input or output stream must be determined. (VOC emissions would

then be calculated as the difference between the usage and the collection rates.)

Tracking solvent use can be done in a number of ways. One is to include cleaning solvents in the plant's material inventory system. The information to be recorded includes the name of the solvent, the amount dispensed during the month, and the cost center in which the solvent is used. Ideally, meters would be installed in lines that supply large amounts of solvent, as in the case of spray gun/line cleaning in some major facilities such as auto assembly plants.

Tracking the fate of collected solvent also can be performed in a number of ways. An acceptable approach must record the total amount that is collected from its respective cost center. To determine the VOC content of spent solvent streams (for use in the material balance), samples should be analyzed periodically in order to correct the shipping weight to account for contaminants.

To properly sensitize middle management to the cost associated with cleaning solvents and improve its ability to identify and control costs, it is necessary to charge the cost of the solvents' use, for both purchase and waste disposal, to the individual cost centers within the plant. This procedure provides the incentive for and allows managers to use the same management techniques to control costs associated with cleaning solvents that they use to control costs for utilities such as steam or cooling water. Each month when the cost sheets are made available, the cost center manager can compare the current usage and costs to historical values. With it, the manager can measure success in reducing usage. Subsequently, when the cost sheet shows an increase in usage, it will signal that remedial action is required.

4.2 SOLVENT MANAGEMENT

Once data are available via the solvent accounting system, plant management and State agencies have a number of options for reducing solvent usage and emissions. The plant management will likely focus on actions that affect usage rates, while the State

agencies will emphasize ways to reduce emissions. Example actions are listed in Table 4-1.

One widely applicable action is to search for alternative cleaning materials that would release less VOC's to the atmosphere. This may be accomplished by evaluating the relative performance of alternative cleaning solutions to those solvents currently emitted in large amounts. Testing for alternatives is an essential step in a search for cleaning fluids that are less volatile and have lower-VOC content and even cleaning solutions with no VOC's that might replace current solvents. Testing alternatives and other actions are discussed separately below.

4.2.1 Testing of Alternative Solvents

A screening test of potential alternative cleaners is the first step. A screening test can identify whether the alternative cleans as well as, better than, or worse than the existing solvent. Solvents that pass the screening test should then be evaluated relative to other criteria (e.g., the effect on performance of a subsequent coating, the relative level of scrubbing effort, solvent and disposal costs, the impacts on the substrate, safety, and recyclability).

ASTM Method D-4828, "Standard Test Method for Practical Washability of Organic Coatings," would appear adaptable for use in comparing the cleaning effectiveness of solvents and other cleaners. It was developed originally to determine the effectiveness of removal of a variety of organic contaminants from a painted substrate by manual or mechanical washing with a sponge and a liquid or powdered cleaner. A modified version of this method, which allows the company to exercise wide latitude in selecting both the contaminants and substrates for test, is presented in Appendix F. The method describes how the contaminant is to be applied to test panels (i.e., the substrate), how the solvent or cleaner is to be applied to the sponge, and the number of wipes to be performed, if appropriate. As designed, the method requires evaluation of the performance based on a visual comparison of the degree to which the contaminants are removed from the test panel. The impact of the

TABLE 4-1. EXAMPLES OF SOLVENT MANAGEMENT ACTIONS

Plant management actions	State agency actions
1. Collect data on a UOS basis in cost centers where high costs have been identified.	1. Require plants to consider accounting on a UOS level if cost center data cannot be compared among plants.
2. Compare usage between two like cost centers or UOS's and require action by larger user.	2. Require plants to submit individual solvent reduction plans.
3. Provide incentives and goals to similar cost centers.	3. Compare solvent usage from like UOS's within a given industry and require justification from higher users.
4. Evaluate potential alternative cleaning solutions.	4. Mandate implementation of specific solvent management techniques.
5. Conduct experiments to determine minimum amount needed for each cleaning task.	5. Require plants to conduct extensive, short-term studies and to commit to take action based on results.
6. Implement an employee suggestion program.	6. Compile and share information on the use of cleaning solutions. Mandate use where appropriate.
7. Form a task force with other plant managers to compare cleaning practices.	7. Compile and share results of alternative cleaning solution tests. Mandate use where appropriate.

solvent on the test panel can also be evaluated qualitatively. Simultaneous tests of the alternative and the existing solvent are preferable to tests at different times.

Another approach would be to wipe each panel until the cleanliness requirements are met. The ratio of required wipes would be a gross measure of relative efficiency.

4.2.2 Plant Management Actions

As with testing for suitable alternative solvents, an accounting system does not, in itself, provide a plant manager with specific pollution information from a cleaning activity (unit operation) in a cost center, nor may it always provide incentive for him or her to take action. For example, if process solvents are reused as cleaning solvents, there may be no usage cost (although a line entry showing the amount used should still be shown). A cost center manager will, however, likely react even in the absence of any regulatory incentive, if the cost alone is incentive to reduce the solvent usage in the expense category. Further, if there are significant monthly fluctuations, the manager may on his or her own initiative, investigate to see how they can be reduced.

One action to focus reduction efforts is to require detailed usage (and waste) records at the cleaning activity level within a cost center. Such a specific analysis will likely be necessary to provide guidance on practical remedial action, especially when numerous cleaning activities are performed within a cost center. Measurement or estimation of additives in the cleaning solvent and contaminants in the collected solvent would also be necessary to determine the actual VOC emissions, and these values are likely to vary with the type of cleaning being performed.

Two approaches to conducting specific analyses at the cleaning activity level are presented in Appendices C and D. Appendix C describes the UOS concept defined as the ensemble around which a material balance for cleaning can be performed. Inputs for the material balance consist of the VOC fraction of all solvents used for cleaning in the system. Assuming no emissions are captured and measured, the outputs are the VOC

content of collected solvent. Emissions are then calculated as the difference between the inputs and outputs. Normalizing data for like UOS's would allow comparison within a plant or among plants within a company or an industry. Records may then be maintained at the UOS level to document gains achieved with subsequent emission reduction techniques and to ensure that the gains are maintained. The approach in Appendix D is similar, but the system boundaries may be more variable, and long term record keeping, if any, would be maintained at the cost center level rather than the UOS. Comparison of results for similar cleaning activities would be more difficult under this approach.

Another way the accounting system could be used is to give a manager of two similar cost centers a basis for comparing the relative solvent usage by those centers. By comparing solvent usage on the unit operation level, the manager could identify the reason for differences and subsequently require action by the larger user to reduce usage. Another option he or she has is to provide incentives and goals to encourage both centers to reduce manufacturing costs (solvent usage and disposal) and emissions.

Still another potential use of an established accounting system is to involve plant managers throughout an industry. One or more task forces could be formed to compare usage and work practices among their facilities and publicize the best for each of a variety of cleaning procedures.

After a cleaning task is targeted for reduction, the plant may conduct tests to determine the minimum amount of solvent necessary for the task and then stipulate that only that amount will be allocated. Implementing an employee suggestion program to encourage the submittal of cost-saving ideas is another possible action.

4.2.3 State Agency Actions

Despite the number of possible cost and environmental incentives for managers to conserve solvent, the cost of solvent in some industries will remain insignificant compared to the cost of labor and the value of enormously expensive parts, regardless of how much solvent is used. The aerospace industry is a good

example, and emissions from cleaning account for about 60 percent of their total emissions.² To effect solvent conservation in such an industry (or in any industry where the data collected in the solvent accounting system do not show acceptable improvement) may require that the State mandate that industry undertake specific solvent management techniques based on information gained from the solvent accounting system. (Some period would be required to ensure that the accounting system is providing valid information before management could be expected to take action based on its results.)

If direct comparisons among plants within an industry are not possible because of differences in the ways that the cost centers are constructed, the State may require detailed studies be initiated using the UOS regimen explained in Appendix C. Standardizing the system around which the material balance is performed is essential to obtain data that would allow comparisons within and perhaps even across industries, although the latter has yet to be demonstrated in practice. Significant differences would be cause for more detailed investigations. Confirmation that the differences are unwarranted could result in changes based on transfer of knowledge from plants that reduce emissions from the more wasteful sources.

A State may also require that plants submit individual solvent reduction plans. Development of such a plan would cause each plant to closely evaluate current emissions and costs associated with the solvent in order to project possibilities for reductions. The American Automobile Manufacturer's Association has suggested such an approach (see Appendix D). Again, for these plans to be useful, the plant would need to evaluate solvent usage on a UOS basis. (Note that there must be some sensitivity to previous reductions by individual plants. A State-imposed requirement for a defined "percent reduction" would penalize companies that previously implemented solvent conservation programs and reward the more wasteful plants.)

A third option is to require plants to conduct extensive, short-term studies of major solvent uses and commit to take

action based on results of the investigations. The State could also use the information from one plant to target corrective action at other plants with the same UOS's.

As a fourth option, the State may compile information on the use of cleaning solutions for an industry and share it with other plants. This action alone, of course, will not necessarily result in reductions in emissions unless the State follows through with subsequent requirements for action.

Finally, States could obtain and disseminate the results of many company's studies of alternative cleaning solutions and, where deemed practical, require companies to switch to alternatives.

4.3 REFERENCES FOR CHAPTER 4

1. Dorfman, M., W. Muir, and C. Miller, INFORM. Environmental Dividends: Cutting more chemical wastes. 1992. pp. 30-35.
2. Personal communication between Serageldin, M., EPA/CPB, and Booth, V., EPA/CPB. 1992. Solvent accounting and utilization procedures in the aerospace industry.

5.0 COSTS OF INSTITUTING ACCOUNTING AND MANAGEMENT

5.1 PLANTWIDE CASE STUDY COSTS

This section presents costs for six of the case studies described in Appendix E. Two plants provided costs for both the accounting system and reduction techniques. One plant provided only solvent accounting system costs. Three plants provided qualitative cost information. Although accounting was conducted at lower levels than the plant level (some at the UOS levels and others at the department level), all of these plants reported only collective, plantwide costs. Similarly, pollution reduction techniques were implemented for individual unit operations, but the plants reported only the plantwide usage and emission reductions, and the plantwide sum of the costs or savings, for all techniques.

Generally, the total capital investment (TCI) for a solvent accounting system includes computer hardware and software programs used to track usage, waste, and emissions. For three plants, however, new software was all that was needed. One plant provided the cost for its existing computer hardware.

Theoretically, the TCI for the reduction techniques undertaken after the accounting system is online would include the cost for changes in equipment to reduce usage, waste, and emissions. In practice, however, none of the pollution reduction techniques implemented by the surveyed plants required new equipment.

Direct annual costs related to solvent accounting include labor required for recording, entering, and analyzing cleaning solvent data; annual training; and maintenance of the computer system and software. Average 1991 wage rates for the labor

requirements at these plants were based on reported 1992 and 1993 wage rates (excluding overhead) that were adjusted downward by 4 percent per year to account for inflation. All labor costs in this section are based on these wage rates and reported hours shown in Appendix E for each plant.

Direct annual costs associated with actual pollution reduction techniques include cleaning solvent usage and waste disposal costs, emission tax charged by State or local air quality management districts, labor required for new equipment or changes in cleaning practices, and maintenance related to the new equipment. Cost impacts associated with changes in production were not considered.

Indirect annual costs for both solvent accounting systems and reduction techniques were calculated as described earlier. Computers and associated software are assumed to have a 10-year life, and the marginal rate of return is assumed to be 10 percent. Therefore, the capital recovery factor (CRF) is 0.16275.

The remainder of this section discusses costs and savings for six of the plants described in Appendix E. Of these, only qualitative information was provided by plants A, D, and F, which is discussed in Section 5.1.1. Accounting system costs for plants C, E, and G are discussed in Section 5.1.2 and summarized in Table 5-1. Costs associated with reduction techniques for plants E and G are presented in Section 5.1.3 and Table 5-2. A comparison with solvent accounting costs is also presented in Section 5.1.3.

5.1.1 Qualitative Cost Information²⁴

Facility A has not performed a cost analysis of its solvent accounting system or of the impact of changes made to better manage solvent. Plant management, however, believes that even if the costs to implement and maintain the accounting system and solvent management techniques are higher than the savings, the difference is small and the benefits are worth the cost. This conclusion is based on the following qualitative assessments.

TABLE 5-1. SUMMARY OF SOLVENT ACCOUNTING COSTS

	Facility C	Facility E	Facility G
A. Total capital investment, \$			
1. Purchased equipment ^a	160	2,200	2,500
2. Installation ^b	32	c	c
3. Initial training	<u>259</u>	<u>0</u>	<u>1,208</u>
	451	2,200	3,708
B. Direct annual costs, \$/yr			
1. Operating labor			
- recording	5,199	2,250	5,400
- data entry	2,790	1,700	9,449
- analysis	2,790	2,000	1,700
- maintenance	0	902	N/A
2. Training	1,109	98	36
3. Maintenance materials	<u>0</u>	<u>902</u>	<u>N/A</u>
	11,888	7,852	16,585
C. Indirect annual costs, \$/yr			
1. Overhead	6,467	3,452	9,929
2. Administrative charges	9	44	74
3. Property tax	4.5	22	37
4. Insurance	4.5	22	37
5. Capital recovery	<u>75</u>	<u>368</u>	<u>620</u>
	6,560	3,908	10,697
D. Total annual costs, \$/yr	18,448	11,760	27,282

N/A = Not available

^aAssumes taxes and freight are included in purchase costs.

^bAssumed to be 20 percent of purchased equipment cost.

^cIncluded in the purchased equipment costs.

TABLE 5-2. SUMMARY OF POLLUTION REDUCTION TECHNIQUE COSTS

	Facility E	Facility G
A. Total capital investment, \$	0	0
B. Annual costs for cleaning ^a		
1. Direct annual costs, \$/yr		
a. Cleaning solvent	(15,600)	(8,000)
b. Waste disposal	0	b
c. Emission fees/taxes	(1,950)	(138)
d. Cleaning labor	N/A	N/A
e. Training	N/A	N/A
f. Maintenance labor	0	N/A
g. Maintenance materials	0	N/A
2. Indirect annual costs, \$/yr	<u>N/A</u>	<u>N/A</u>
	(17,550)	(8,138)
C. Accounting system costs, \$/yr ^c	11,760	27,282
D. Total annual cost, \$/yr ^d	(5,790)	19,144

N/A = Not available

^aThe annual costs are the incremental costs (or savings) that resulted after implementation of pollution reduction techniques.

^bIncluded in the cleaning solvent cost.

^cSee Table 5-1 for the derivation of accounting costs.

^dTotal annual cost is the sum of the annual cost for the solvent accounting system and annual cost (savings) for the pollution reduction techniques.

Limitations on acetone, which is one solvent management technique implemented, have reduced the purchase and waste disposal costs for this solvent. Another change, replacing Tipsolve™, a proprietary cleaner composed of a mix of solvents, with dibasic acid ester (DBE) to lower evaporation, also reduced purchase and waste disposal costs. Plant management indicates that cleaning labor costs have increased slightly as a result. No equipment was purchased for the accounting system or to aid reductions.

Plant management at Facility D also has not performed a cost analysis, but it, too, provided qualitative information. Facility D indicates that costs for the accounting system may exceed any savings achieved during the first year of implementation but maintains that will change within a few years. Tracking data provided by the accounting system will help identify areas where solvent usage, waste, and costs can be reduced.

Facility F reports reduced usage and waste disposal and associated costs due to its accounting system and solvent reduction efforts. The plant estimates a combined annual cost reduction of \$1,000 to \$1,500 for both usage and waste due to solvent reduction techniques. Plant management indicates that implementing the solvent accounting system has made employees more conscious of solvent usage, and this awareness has contributed to reductions.

5.1.2 Solvent Accounting Costs

Plants C, E, and G provided data used to estimate the costs for solvent accounting systems. The data show both the TCI and the annual cost do not depend on facility size.

The TCI included only the cost for computer software and initial training to use the software because all three plants installed the new software on existing computers. The TCI for facilities E and G, both with approximately 100 employees, was estimated to be about \$2,200 and \$3,708, respectively. For facility C, a larger plant (believed to be approximately 800 employees), the TCI was estimated to be only \$451.

Total annual costs for accounting systems range from about \$12,000 to \$27,000 for the smaller Facilities E and G and \$18,000 for Facility C, an overall average of \$19,000/yr. Additional detail about the procedures used to determine these costs for the three plants is presented below.

5.1.2.1 Facility C.^{5,6} The total annual cost for the solvent accounting system at Facility C was estimated to be a little more than \$18,000/yr. The accounting system was implemented in 1992 on existing computer hardware and from an existing software package. The original cost for the existing computer and software was \$4,200. Because the plant already owned this equipment and software, these costs were not included as part of the cost of the accounting system. An initial labor cost of \$160 was incurred from in-house development of the software program used. Installation was assumed to equal 20 percent of the development cost. The plant provided initial training for operators regarding recording procedures at a cost of \$259. For analysis purposes, these initial labor costs were treated as a capital cost.

As shown in Table 5-1, annual labor costs for operating the accounting system include \$5,199/yr for recording information, \$2,790/yr for data entry, and \$2,790/yr for evaluating the data. The cost for annual training is \$1,109/yr. No maintenance costs are associated with the computer software.

5.1.2.2 Facility E.^{7,8} As noted in Appendix E, Case Study E, this facility has tracked cleaning solvent use since 1989. The tracking procedures have changed over the years; this analysis presents the costs for the computerized system that was implemented in 1991.

The TCI for the solvent accounting system was reported to be \$2,200 to develop and install the software system on an existing computer. No training costs were associated with implementing computerized accounting.

Annual operating labor costs for 1991 include \$2,250 for recording information, \$1,700 for data entry, and \$2,000 for

annual analysis. Annual training for the employee who performs data entry costs \$98. Annual maintenance and material costs for upkeep of the software system are \$1,804. In summary, total direct annual costs for the accounting system are \$7,852/yr. As shown in Table 5-1, total indirect costs are \$3,908/yr, and the total annual cost is \$11,760.

5.1.2.3 Facility G.^{9,10} Although facility G first implemented a solvent accounting system when the plant opened in 1985, this analysis presents the costs for the upgraded system and procedure implemented in 1991.

The TCI for implementing and installing the computer software on existing hardware was estimated to be \$3,708, of which \$2,500 was for the purchase and installation of software and \$1,208 was for initial employee training. Operators, the data entry employee, and the employee evaluating data were trained.

Annual labor costs for the solvent accounting system include \$5,400 for data recording, \$9,449 for data entry, and \$1,700 for data analysis. Annual training costs, which totaled \$36 in 1991, are incurred from the plant's annual training meeting and from training new hires. Indirect costs for the solvent accounting system are detailed in Table 5-1. The total annual cost for the solvent accounting system is \$27,282, with a direct cost of \$16,585 and an indirect cost of \$10,697.

5.1.3 Cost of Pollution Reduction Techniques

Only two facilities, E and G, provided the cost of implementing pollution reduction techniques; Facility C provided partial costs. As shown in Table 5-2, Facility E spends \$11,760/yr for its accounting system and saves \$17,550/yr due to pollution reduction techniques implemented, for an overall savings. Facility G also provided information for both the accounting system and pollution reduction technique costs; the plant spends \$27,282/yr on its accounting system and saves \$8,138/yr as a result of pollution reduction techniques. Plant management at Facilities E, F, and G all indicate that the

accounting system has made employees more conscious of solvent usage, and this awareness has contributed to reductions.

5.1.3.1 Facility C.^{3,4} As discussed in Appendix E, Facility C implemented a variety of reduction techniques before initiating a complete solvent accounting system in April 1992. The plant had maintained solvent disposal records for several years, and cleaning wastes were the only source. The plant used these records to show pollution reduction techniques resulted in waste reductions of 35,000 gal for a cost savings of \$100,000 in 1991. (Knowledge of the magnitude of waste generated also may have spurred development of the pollution reduction techniques.) Other cost savings also may have been achieved, but without accounting records, they could not be documented. Those savings in waste costs alone, though, exceed the cost of the current solvent accounting system by about \$75,000 annually. Eventually the plant expects to use the accounting results to identify additional areas where solvent use, waste, and costs can be reduced.

5.1.3.2 Facility E.^{7,8} As discussed in Appendix E, Facility E reduced VOC emissions from cleaning solvents two ways, by limiting access to the solvents and switching to using glycol ethers rather than methyl ethyl ketone (MEK) and methyl isobutyl ketone (MIBK). As a result, the plant reported cleaning solvent emissions were reduced by 6.5 tons per year (tons/yr) between 1988 and 1991. The plant did not report actual usage or waste generation. Instead, they assumed that the usage and emissions reductions are equal. Therefore, there is no change in waste generation. The plant did not indicate whether the pollution reduction techniques affected labor requirements.

The reduction techniques did not involve any equipment changes; thus, the TCI is zero. Unit costs for the glycol ethers, MEK, and MIBK were all reported by the plant as \$1.20/lb at the time of the substitution in 1990. Assuming these unit costs did not change in 1991, the usage reduction achieved a cost savings of \$15,600/yr. Waste disposal costs were assumed to be

unchanged. The local air quality management district charges \$300/ton of VOC emissions, resulting in another savings of \$1,950/yr. The impact, if any, on labor costs was not provided. In summary, the reduction techniques saved the plant \$17,550/yr. As shown in Table 5-2, these savings exceed the cost of the solvent accounting system by nearly \$5,800/yr.

5.1.3.3 Facility G.^{9,10} Facility G has tracked cleaning solvent usage since the plant opened. This allowed the plant to document cost reductions achieved with pollution reduction techniques implemented in 1986 and 1987 (no reduction techniques have been implemented since). The plant documented a reduction in solvent and waste costs of \$8,000 in 1987. The change in unit costs since 1987 for the solvent and waste were not provided to EPA; thus, the 1991 savings was assumed to be \$8,000. Emission fees (\$300/ton) paid to the plant's air quality management district declined from \$150/yr to \$12/yr, for a savings of \$138. The incremental cost of labor is unknown; as is that of the overhead costs. Total savings from solvent reduction techniques is \$8,138/yr. Since facility G spends \$27,282/yr on its current accounting system, the net annual cost is \$19,144.

5.2 REFERENCES FOR CHAPTER 5

1. Office of Air Quality Planning and Standards Control Cost Manual (4th ed.). U. S. Environmental Protection Agency. Research Triangle Park, NC. Publication No. EPA 450/3-90-006. January 1990.
2. Telecon. Randall, D., MRI, with Joyner, L., Hatteras Yachts. July 24, 1992. Solvent accounting and management procedures.
3. Telecon. Schmidtke, K., MRI, with Brown, G., Graphics Technology International. August 11 and 14, 1992. Solvent accounting and management procedures.
4. Telecon. Schmidtke, K., MRI, with Facility F. September 1, 1992. Solvent accounting and management procedures.
5. Telecon. Schmidtke, K., MRI, with Irish, D., Flexcon Corporation. August 11 and 17, 1992. Solvent accounting and management procedures.

6. Telecon. Schmidtke, K., MRI, with Irish, D., Flexcon Corporation. March 3, 1993. Costs and impacts of solvent accounting and management procedures.
7. Telecon. Schmidtke, K., MRI, with Facility E. August 27 and November 24, 1992. Solvent accounting and management procedures.
8. Telecon. Schmidtke, K., MRI, with Facility E's consultant. November 25, 1992. Costs and impacts of solvent accounting and management procedures.
9. Telecon. Schmidtke, K., MRI, with Koenig, J., SupraCote, Inc. September 2 and December 3, 1992. Solvent accounting and management procedures.
10. Letter from Koenig, J., SupraCote, Inc., to Schmidtke, K., MRI. January 11, 1993. Costs and impacts of solvent accounting and management procedures.

APPENDIX A.
TERMS AND DEFINITIONS FOR SOLVENT CLEANING

APPENDIX A.

TERMS AND DEFINITIONS FOR SOLVENT CLEANING

This Appendix presents a glossary of terms and definitions used in this report.

Cleaning activity

Physical removal of foreign material from substrate being cleaned. Includes actions such as wiping, brushing, flushing, or spraying.

Cleaning classification

For convenience, cleaning has been considered to have three main classifications: (1) cleaning of external surfaces, (2) cleaning of interior surfaces (i.e., containers), and (3) cleaning of removable parts.

Cleaning of external surfaces

Solvent is applied to the "external surface" being cleaned (as contrasted to the interior of tanks or pipes). Surfaces that fall within this classification include rollers in printing machines, wings of airplanes, floors, tables, and walls. The "cleaning activities" applied to the external surface may include mopping, brushing, or spraying and use "cleaning tools" such as rags, brushes, mops, or spraying equipment.

Cleaning of internal surfaces/containers

Solvent is applied to an interior surface for cleaning. Surfaces may include the inside of tanks/vessels, batch reactors, columns, heat exchangers, paint spray booths, and fuel tanks. The "cleaning activities" applied may include flushing, agitation, spraying, and mopping or brushing. Any combination of activities

may be used, depending on the shape and size of the "unit operation" and on the type residue that is being removed.

Cleaning of parts

Solvent engulfs the entire surface of the item (part) as it is dipped in a container of solvent, or the part is cleaned above the container by a cleaning activity such as spraying or wiping. Equipment, the "unit operation," where this might take place, includes part washers, batch-loaded cold cleaners, ultrasonic cleaners, and spray gun washers.

Cleaning practices

A repeated or customary action that is specific to an industry. An example is nightly maintenance of a spray booth in an automobile assembly plant

Cleaning tool

An item used to aid cleaning, such as wiping rags, brushes, scrapers, or water jets.

Closed-loop recycling (in-process recycling)

Reuse or recirculation of a chemical material within the boundaries used to develop a material balance around a "unit operation system." A recovery or reclamation (R or R) unit operation may be within the boundaries selected for the primary unit operation system if it is:

1. Solely dedicated. The chemical is reused only for cleaning the primary unit operation.
2. Physically integrated. The R or R operation is connected to the primary unit operation by means of piping, so that it is not possible to perform the material balance around the primary unit operation system without including it.

Hazardous Air Pollutant (HAP)

Any of almost 200 substances identified as air toxics in Section 112 of the Clean Air Act Amendments of 1990.

In-process recycling

(See closed-loop recycling).

Line flushing

Line flushing is the procedure of completely cleaning out a large paint circulating system such as those found at auto assembly plants. The system includes the paint mix tanks and perhaps hundreds of feet of pipe or piping. This procedure is only necessary when a system is inadvertently contaminated or for a routine color change.

Although the system is essentially closed loop, some losses can occur during the flushing (i.e. through various vents, from transfer operations and from the paint mix tanks). In the information supplied to the Agency, automobile assembly plants with closed loop systems estimated a 10 percent loss from the line flushing operation, independent of the solvent used, but they provided no data or rationale to support the estimates.

Onsite recycling

An R or R unit operation located within the plant boundaries from which clean solvent is returned to a process other than that which generated the waste solvent. A material balance for the R or R unit operation (distillation, filtration, etc.) should be developed independently.

See "storage containers." (Emissions during cleanup of the R or R unit operation should not be overlooked when determining the long-term solvent efficiency of the unit.)

Offsite recycling

An R or R unit operation system located outside of the plant boundaries.

Pollution prevention

Practices or process changes that decrease or eliminate the creation of emissions (or wastes) at the source. Such prevention techniques include use of new materials, modification of equipment, and changes in work practices.

Product substitution

Replacement of any product or raw material intended for an intermediate or final use with another. This substitution is a source reduction activity if either the VOC emissions or the quantity of waste generated is reduced.

Purging

The process wherein individual paint applicators and portions of paint delivery lines are emptied of one color paint, cleaned, and filled with another. This is a common cleaning practice in the automobile assembly industry.

Reclaim

"Reclaim" means a material is processed or regenerated to recover a usable product. (See recycle).

Recovery or regeneration (R or R) unit operation

A device for purifying solvent that may use any of a variety of techniques, including extraction, distillation, filtration, adsorption, or absorption.

Recycle

"Recycled" means used, reused, or reclaimed (40 CFR 261.1(b)(7)). A material is "used or reused" if it is either employed as an ingredient (including its use as an intermediate) to make a product. For example, when solvent recovered by distillation is reused in the plant.

Reuse

See "used."

Source reduction

Any activity or treatment that reduces or eliminates the generation of VOC emissions (or waste), including product substitution or elimination and pollution prevention.

Storage container

Emissions from storage containers are to be included in a material balance.

Treatment

Destruction or degradation of waste using techniques such as combustion or neutralization to produce material that is less toxic and more environmentally benign. (See recycle).

Unit operation (UO)

An industrial operation, classified or grouped according to its function in an operating environment. Examples include distillation columns, paint mixing vessels (tanks), spray booths, parts cleaners and printing machines. A unit operation may

consist of one or more items of equipment, e.g., both a reactor and a mixing vessel or several mixing vessels. There may be considerable variation in the type of unit operations from one industry to another. (See unit operation system.)

Unit operation system (UOS)

The ensemble of equipment around which a material balance is performed. A UOS includes all possible points/sources that could result in losses to the atmosphere as a result of its being cleaned, including losses during dispensing of solvent, losses from residual solvent on or in cleaning tools (such as rags), losses from solvent storage, etc. An item of equipment used for cleaning parts by definition is a unit operation, therefore, carry-out losses during removal of cleaned parts should be considered in a material balance.

Used (or reused)

A material is "used or reused" if it is employed as an ingredient (including use as an intermediate) in an industrial process to make a product (for example, in purifying a waste solvent, distillation bottoms from one column may be used as feedstock in another).

Volatile Organic Compounds (VOC)¹

[NOTE: This definition may change. The Code of Federal Regulations (40 CFR 51.100[s]) presents the current legal definition.] Any compound of carbon, excluding carbon monoxide, carbon dioxide, carbonic acid, metallic carbides or carbonates, and ammonium carbonate, which participates in atmospheric photochemical reactions.

1. This includes any such organic compound other than the following, which have been determined to have negligible photochemical reactivity: methane; ethane; methylene chloride (dichloromethane); 1,1,1-trichloroethane (methyl chloroform); 1,1,1-trichloro-2,2,2-trifluoroethane (CFC-113); trichlorofluoromethane (CFC-11); dichlorodifluoromethane (CFC-12); chlorodifluoromethane (CFC-22); trifluoromethane (FC-23); 1,2-dichloro 1,1,2,2-tetrafluoroethane (CFC-114); chloropentafluorethane (CFC-115); 1,1,1-trifluoro

2,2-dichloroethane (HCFC-123); 1,1,1,2-tetrafluoroethane (HFC-134a); 1,1-dichloro 1-fluoroethane (HCFC-141b); 1-chloro 1,1-difluoroethane (HCFC-142b); 2-chloro 1,1,1,2-tetrafluoroethane (HCFC-124); pentafluoroethane (HFC-125); 1,1,2,2-tetrafluoroethane (HFC-134); 1,1,1-trifluoroethane (HFC-143a); 1,1-difluoroethane (HFC-152a); and perfluorocarbon compounds which fall into these classes:

(a) Cyclic, branched, or linear, completely fluorinated alkanes;

(b) Cyclic, branched, or linear, completely with fluorinated ethers with no saturations;

(c) Cyclic, branched, or linear, completely fluorinated tertiary amines with no saturations; and

(d) Sulfur containing perfluorocarbons with no saturations and with sulfur bonds only to carbon and fluorine.

2. For purposes of determining compliance with emission limits, VOC will be measured by the test methods in the approved State implementation plan (SIP) or 40 CFR Part 60, Appendix A, as applicable. Where such a method also measures compounds with negligible photochemical reactivity, these negligibility-reactive compounds may be deducted from the reported VOC if the amount of such compounds is accurately quantified, and such exclusion is approved by the enforcement authority.

3. As a precondition to excluding these compounds as VOC or at any time thereafter, the enforcement authority may require an owner or operator to provide monitoring or testing methods and results demonstrating, to the satisfaction of the enforcement authority, the amount of negligibly-reactive compounds in the source's emissions.

4. For the purposes of Federal enforcement for a specific source, the EPA shall use the test method specified in the applicable EPA-approved SIP, in a permit issued pursuant to a program approved or promulgated under Title V of the Act, or under 40 CFR Part 51, Subpart I or Appendix S, or under 40 CFR Parts 52 or 60. The EPA shall not be bound by any State determination as to appropriate methods for testing or monitoring

negligibly-reactive compounds if such determination is not reflected in any of the above provisions.

Waste minimization

Means the reduction, to the extent feasible, of hazardous waste that is generated or subsequently treated, stored or disposed. It includes any source reduction or recycling activity undertaken by a generator that results in either (1) the reduction of total volume or quantity of hazardous waste, or both, so long as such reduction is consistent with the goal of minimizing present and future threats to human health and the environment. In order of preference there are: source reduction, recycling, and treatment.

Work practice

This term is reserved for specific human activities within industry that lead to a reduction in VOC emissions (or waste). The activities include increased operator training, management directives, segregation of the waste solvent, and practices that lead to a reduction in cleaning frequency. It does not include the use of specialized equipment, such as solvent dispensers.

REFERENCES FOR APPENDIX A

1. 40 CFR Part 51, Vol. 57, No. 22, February 3, 1992.

APPENDIX B.
REVIEW AND SUMMARY OF STATE AND LOCAL CLEANING REGULATIONS

APPENDIX B.

REVIEW AND SUMMARY OF STATE AND LOCAL CLEANING REGULATIONS

B.1 REVIEW OF STATE AND LOCAL REGULATIONS ON SOLVENT CLEANING

A survey of State and local agencies was conducted to obtain information on existing cleaning solvent regulations. Information was received from 45 agencies. Only 13 have specific requirements on the use of cleaning solvents, and each of these is summarized below. A list of all agencies have provided information is in Section B.2 of this appendix.

B.1.1 Alabama, Jefferson County¹

All regulated surface coating facilities are subject to recordkeeping requirements for cleaning solvents. For each solvent, a plant must record the daily amount used; the density; and the VOC, solids, water, and exempt VOC weight and volume fractions.

B.1.2 Alabama, Huntsville²

Surface coating regulations require maintenance of daily records on the quantity in gallons of all organic solvents used for wash or cleaning.

B.1.3 Arizona³

All VOC emissions from solvent washings shall be considered in the emission limitations for a facility unless the solvent is directed into containers that prevent evaporation to the atmosphere.

B.1.4 California, Bay Area⁴

Surface preparation, cleaning, and removal of coating, ink, or paint in surface coating and other specified industries is regulated under this rule. Specifically, the regulations require

that: (1) no open containers be used to store or dispose of cloth or paper impregnated with organic compounds, (2) no open containers be used to store spent or fresh organic compounds, and (3) no organic compounds be used to clean spray equipment unless some mechanism for collecting the cleaning compounds and minimizing their evaporation to the atmosphere is used.

B.1.5 California, South Coast⁵

This rule regulates cleaning during production, repair, and maintenance of parts, products, tools, machinery, equipment, and general work areas, as well as storage and disposal of VOC-containing materials used in solvent cleaning. Facilities affected by this rule include manufacturing plants, printing presses, shipyards, motor vehicle assembly plants, and repair and refinishing facilities such as auto garages, auto body shops, and workshops for repairing buses, aircraft, trains, and trucks.

Four broad categories of VOC and exempt compound emissions from solvent cleaning are regulated under this rule. These are emissions from surface preparation, repair and maintenance cleaning, cleaning of application equipment, and use of remote-reservoir cold cleaners. The main requirements specified in this rule are:

1. The VOC content and partial pressure limits on solvents used for:
 - a. Substrate cleaning during the manufacturing process and surface preparation for coating, adhesives, or ink applications;
 - b. Repair and maintenance cleaning;
 - c. Cleaning coating and adhesives application equipment;
 - d. Cleaning polyester resin application equipment;
 - e. Cleaning inks and varnishes application equipment in screen printing, lithographic printing, and other graphic arts printing operations; and
 - f. Manufacturing and maintenance cleaning of electronic assemblies;
2. Specific cleaning methods and devices must be used to clean;

3. Compliance with the rule may be achieved by using collection and control systems, subject to certain performance standards;

4. Atomizing any solvent into open air is prohibited;

5. The VOC-containing materials used in solvent cleaning and cloth and paper moistened with solvents shall be stored in nonabsorbent, nonleaking containers that shall be kept closed at all times except when filling or emptying; and

6. Daily records on the amount of solvent used are required.

Additionally, cleaning associated with semiconductor manufacturing, aerospace assembly and component manufacturing, coating and ink manufacturing, and motor vehicle assembly line coating are regulated under separate regulations.

B.1.6 California, Ventura County⁶

This rule regulates the use of cleaning solvents for paper, fabric, and film coating; surface coating of metal parts and products; aerospace assembly and component manufacturing; polyester resin material operations; motor vehicle and mobile equipment coating; graphic arts; adhesives; and semiconductor manufacturing. The county also has a proposed rule addressing general cleaning. The specific requirements per industry are listed below.

B.1.6.1 Paper, Fabric, and Film Coating.

1. Limit VOC content in cleaning solvents to 200 grams per liter (g/L) (1.7 lb/gal) of solvent; and

2. Maintain daily records of solvent used by type of solvent and corresponding State identification number.

B.1.6.2 Surface Coating of Metal Parts and Products

1. Limit VOC content of solvent used for surface preparation to 200 g/L (1.7 lb/gal) of solvent;

2. Use a solvent with a VOC content less than 200 g/L (1.7 lb/gal) for cleaning coating operations equipment or use a solvent with a vapor pressure less than 45 millimeters of mercury (mm Hg) (1.8 in. Hg) and flush the solvent through the equipment into a closed container; and

3. Maintain manufacturers' specifications on solvents used for equipment cleaning and surface preparation and maintain daily records on type of solvent, reactive organic compounds (ROC) content of solvents in g/L, volume of solvent used, and composite vapor pressure of solvent and how it was determined.

B.1.6.3 Aerospace Assembly and Component Manufacturing

1. Limit VOC content of solvent used for surface preparation to less than 250 g/L (2.1 lb/gal) of solvent;
2. Clean guns in an enclosed gun washer; and
3. Maintain daily usage records.

B.1.6.4 Polyester Resin Material Operations. Limit use on lines, brushes, spray equipment, and personnel of cleaning materials containing greater than 200 g/L (1.7 lb of VOC/gal) of material as applied, or where the initial boiling point of the cleaning agent is less 190°C (370°F), to less than 57 L (15 gal) per calendar week unless a reclamation process is in place.

B.1.6.5 Motor Vehicle and Mobile Equipment Coating Operations. Maintain monthly records consisting of the following information:

1. Identification of each solvent and its uses;
2. ROC content of each solvent in g/L; and
3. Volume of solvent used; if purchasing records are used for this, then manifests and recycling records must also be maintained.

B.1.6.6 Graphic Arts. Limit vapor pressure to less than 33 mm Hg (1.3 in. Hg) for all solvents and:

1. Limit VOC content to 450 g/L (3.8 lb/gal) for substrate surface cleaning;
2. Limit VOC content to 750 g/L (6.3 lb/gal) for repair and maintenance cleaning;
3. Limit VOC content to 950 g/L (7.9 lb/gal) for coating and adhesives equipment cleaning;
4. Limit VOC content to 800 g/L (6.7 lb/gal) for radiation curing ink removal cleaning;

5. Limit VOC content to 800 g/L (6.7 lb/gal) for ink application equipment cleaning from lithographic and letterpress printing, and 450 g/L (3.8 lb/gal) from other printing; and

6. Limit VOC content to 200 g/L (1.7 lb/gal) for all other cleaning operations.

B.1.6.7 Adhesives.

1. Limit VOC content in solvent used for surface preparation to less than 200 g/L (1.7 lb/gal) of solvent; and

2. Clean coating application equipment in an enclosed gunwasher with solvent with a vapor pressure less than 45 mm Hg (1.8 in. Hg).

B.1.6.8 Semiconductor Manufacturing.

1. Subject the solvent cleaning stations to degreasing regulations; and

2. Limit VOC content in solvent used for surface preparation to less than 200 g/L (1.7 lb/gal) of solvent.

In addition, Ventura County also has the following freestanding requirements:

1. Emissions of ROC's (Reactive Organic Compounds) from cleaning of any article, machine, or equipment should be included with other emissions of that type of emissions in order to determine compliance with Rule 66; and

2. Proposed Rule 317 focuses on substitution and reformulation of cleaning solvent as a means of reducing ROC emissions. The regulatory alternatives proposed include:

a. Use of closed containers for all cleaning activities;

b. Vapor pressure and ROC content limits on all cleaning solvents; and

c. Prohibition of certain cleaning activities, including flushing solvent from a solvent container greater than 0.47 L (16 fluid ounces) unless the used solvent is collected in a container; soaking objects in a container that is open except when depositing objects; wipe cleaning where the solvent drips from the materials, unless it is collected; atomizing solvent into open air; and removing solvents from objects with compressed air.

B.1.7 Kansas⁷

Rule 28-19-73 requires most miscellaneous metal parts and products and metal furniture facilities with total VOC potential emissions greater than 2.72 Mg/yr (3 tons/yr) to keep daily records of the type, density, and amount of solvent used for purge and equipment cleaning. Automobile, light duty truck, and metal car manufacturing plants; plants that perform customized top coating of automobiles and trucks; and automobile refinishing plants are exempted.

Rule 28-19-76 regulates the use of cleaning solvents at lithographic printing major sources (VOC potential emission rate ≥ 91 Mg/yr [≥ 100 tons/yr]). If such sources use cleaning solvents containing VOC's, the solvent container must be tightly covered during transport and storage, and cleaning rags used in conjunction with cleaning solvents must be placed, when not in use, in tightly closed containers and collected for proper disposal or recycle. Furthermore, solvent must be extracted from the rags prior to laundering, and monthly records on the quantity of cleaning solvents used must be maintained.

B.1.8 Michigan, Wayne County⁸

This rule requires that paint manufacturing equipment and paint shipping containers be cleaned by methods and materials that minimize the emission of VOC's. Such methods and materials shall include one of the following:

1. Hot alkali or detergent cleaning;
2. High-pressure water cleaning; or
3. Cleaning using an organic solvent if the equipment being cleaned is completely covered or enclosed, except for an opening that is no larger than necessary to allow for safe clearance based on the method and materials being used.

In addition, the wash solvent shall be stored only in closed containers, unless it is demonstrated to be a safety hazard, and disposed of in a manner such that not more than 20 percent, by weight, is allowed to evaporate into the atmosphere.

B.1.9 Missouri⁹

Cleaning solvents containing VOC's are regulated in offset lithographic, flexographic, and rotogravure printing operations. The cleaning solvents must be kept in a tightly covered tank or container during transport and storage, and the cleaning cloths used with the cleaning solvents must also be placed in tightly closed containers when not in use and while awaiting disposal. The cleaning cloths should be properly cleaned and disposed of and processed in such a way that as much of the solvent as possible is recovered for further use or is destroyed. Cleaning and disposal methods must be approved by the director, and an owner/operator may use an alternative method only if he or she can demonstrate that the emission reduction is significant and the method is approved by the director. Each printer subject to this regulation is required to maintain records on the quantity of cleaning solvents used monthly.

B.1.10 Ohio, Dayton¹⁰

This rule regulates organic material emissions from activities using photochemically reactive materials. The use of these materials in cleaning is specifically included in this rule. Emissions from cleaning activities must be included in the calculation of amount of photochemically reactive compound emissions. These emissions have set daily and hourly limits, and the requirements in Dayton specifically include cleaning emissions in the compliance determination process.

B.1.11 Pennsylvania, Allegheny County¹¹

The regulation restricts total VOC emissions from surface coating processes (and associated cleaning) to 1.4 kg/hr (3 lb/hr), 7 kg/d (15 lb/d), or 2,355 kg/yr (2.7 tons/yr). Plants are required to keep daily records of the quantity, composition, and density of solvents used for cleaning.

B.1.12 Tennessee, Metropolitan¹²

The State includes emissions of cleaning solvents in the total facility emissions. Good work practices, use of solvents that result in low VOC emissions, and daily and annual records of

solvent use, including cleaning, are required for plants manufacturing miscellaneous metal parts and products.

B.1.13 Wisconsin¹³

The State requires that good operating procedures for solvents be used in cleaning. Recordkeeping, including daily usage and VOC content, is required at facilities with air emissions of 0.25 ton/d (0.23 Mg/d) or more on any one day of operation or 50 tons/yr (45 Mg/yr) or more of all primary air contaminants. Wash solvents for cured and air-dried coatings are also regulated. Unless used wash solvent is collected in containers that prevent evaporation, VOC emissions from solvent washings will be considered in the emission limitations set for cured and air-dried coatings.

B.2 SUMMARY OF STATE AND LOCAL REGULATIONS ON SOLVENT CLEANING

Typical requirements in the State and local regulations described above for cleaning using organic solvents include:

1. Limits on the VOC content and partial pressure of cleaning solvents;
2. Daily or monthly records of solvents;
3. Storage of waste solvent in closed containers; and
4. Equipment cleaning while completely covered or enclosed.

In addition, the regulations:

1. Prohibit specific cleaning methods and devices; and
2. Restrict or prohibit certain cleaning activities.

This section summarizes responses to an information request that was sent to STAPPA/ALAPCO for distribution to State and local agencies. A total of 44 agencies responded to the request between July 1992 and February 1993. Information about proposed Rule 1171 in California's South Coast Air Quality Management District is also summarized.

The information is presented in three tables. Table B-1 identifies whether the agency regulates cleanup solvents, indicates the actions or industries that are regulated, and summarizes the regulatory requirements. Table B-2 summarizes how cleaning is addressed in the permitting process, the aspects of cleaning checked during plant inspections, and the plans for

future cleaning-solvent regulations. Table B-3 presents suggestions from the agencies for EPA guidance on cleanup solvent emission control techniques, the types of unit operations cleaned at inspected plants, and available case study information on control techniques.

Listed below are definitions for all of the acronyms that appear in the three tables:

1. VOC: Volatile Organic Compound;
2. ROC: Reactive Organic Compound;
3. MSDS: Material Safety Data Sheet;
4. NFPA: National Fire Protection Association;
5. BARCT: Best Available Retrofit Control Technology;
6. RACT: Reasonably Available Control Technology; and
7. BACT: Best Available Control Technology.

TABLE B-1. SUMMARY OF STATE QUESTIONNAIRE RESPONSES

State	Cleanup solvent specific regs?	What is regulated?	Specific requirements
Alabama, Jefferson County	Yes	All regulated surface coating facilities.	Daily records of all cleanup solvents.
Alabama, Huntsville	Yes	Coating line wash and cleanup associated with surface coating.	Record of daily quantity in gallons of all organic solvents used for wash or cleanup.
Alabama, State	No		
Arizona, State	Yes	All volatile organic compound (VOC) emissions from solvent washing shall be considered in emission limitations unless solvent is directed into containers that prevent evaporation.	NA
Arkansas, State	No		
California, Lassen County	No		
California, State ^a	No		

TABLE B-1. (continued)

State	Cleanup solvent specific regs?	What is regulated?	Specific requirements
California, South Coast	Yes, Proposed Rule 1171	<p>Cleaning during production, repair, or maintenance of parts, tools, machinery, equipment or general work areas, as well as to all persons who store and dispose of VOC-containing materials used in solvent cleaning operations.</p> <p>Facilities affected by this rule include: manufacturing plants; printing presses; shipyards; motor vehicle assembly plants; repair and refinishing facilities such as auto garages, auto body shops, and workshops for the repair of buses, aircraft, trains and trucks.</p>	<p>Sets limits on solvents used for substrate cleaning during <u>manufacturing process and surface preparation for coating, adhesives, or ink applications</u> to no more than 200 g VOC/L (1.7 lb/gal) of material being used; establishes limits for solvent used for <u>repair and maintenance cleaning</u> that the solutions used should not have a VOC content of more than 850 g/L (7.1 lb/gal) of material and a VOC composite partial pressure of more than 20 mm Hg (0.79 in. Hg) at 20°C (68°F); establishes limits for solvents used for <u>cleaning coating and adhesives application equipment</u> to be no more 950 g VOC/L (7.9 lb/gal) of material and VOC composite partial pressure of 35 mm Hg (1.4 in. Hg) at 20°C (68°F); establishes limits for solvents used for <u>cleaning inks or varnishes application equipment</u> in screen plating shall not have a VOC content of more than 1,070 g/L (8.9 lb/gal) of material and a VOC composite partial pressure of more than 5 mm Hg (0.20 in. Hg) at 20°C (68°F), in lithographic printing the VOC content should not exceed 850 g/L (7.1 lb/gal) of material and a composite partial pressure of more than 25 mm Hg (0.98 in. Hg) at 20°C (68°F), and all others should not have a VOC content of more than 100 g/L (0.83 lb/gal) of material and VOC composite partial pressure of more than 3 mm Hg (0.12 in. Hg) at 20°C (68°F); and requires use of specific cleanup devices and methods.</p>
California, Bay Area	Yes	<p>All surface preparation; cleanup; coating, ink, and paint removal in surface coating and other specified industries.</p>	<p>No open containers can be used for the storage or disposal of cloth or paper impregnated with organic compounds; no open container storage of spent or fresh organic compounds; and no usage of organic compounds for the clean-up of spray equipment unless equipment for collection of the cleaning compounds and minimizing its evaporation to the atmosphere is used.</p>

TABLE B-1. (continued)

State	Cleanup solvent specific regs?	What is regulated?	Specific requirements
California, Ventura County	Yes	Paper fabric and film coating, surface coating of metal parts and products, aerospace assembly and component manufacturing, polyester resin material operations, motor vehicle and mobile equipment coating operations, and graphic arts. Proposed rules include: adhesives, semiconductor manufacturing, and general cleanup operations.	<p>Paper, Fabric and Film Coating</p> <ul style="list-style-type: none"> - limit usage of cleanup solvents to 200 g of VOC per liter of solvent or the reactive organic compound (ROC) emissions from cleanup are < 120 g/L (< 1.0 lb/gal) of solvent used, or the emissions are collected and reduced. - maintain daily records on the amount of cleanup solvent used and its state I.D. number. <p>Surface Coating of Metal Parts and Products.</p> <ul style="list-style-type: none"> - limit use of equipment cleanup solvents to < 200 g ROC/L unless: the spray equipment is cleaned in a solvent container that prevents evaporation, the cleaned equipment is drained and the returned solvent is stored in a container that prevents evaporation, or the composite ROC vapor pressure of the solvent is < 45 mm Hg (1.8 in. Hg) at 20°C (68°F). - No ROC-containing solvents can be used for substrate surface cleaning. - coating operation equipment cleaning < 200 g/L (1.0 lb/gal) or use a solvent with a vapor pressure less than 45 mm of Hg (1.8 in. Hg) and flush solvent through equipment into a closed container. - maintain manufacturer's specification sheets on solvents used for equipment cleaning and surface preparation cleaning. - maintain records on a daily basis for the following: type, ROC content of solvent in g/L, volume of solvent used, composite vapor pressure of solvent and how it was determined.

TABLE B-1. (continued)

State	Cleanup solvent specific regs?	What is regulated?	Specific requirements
California, Ventura County (cont'd)			<p>Aerospace Assembly and Component Manufacturing.</p> <ul style="list-style-type: none"> - surface cleaning solvents must contain < 200 g ROC/L (1.7 lb/gal) or have a vapor pressure \leq 25 mmHg (0.98 in. Hg) at 20°C (68°F). - cleaning must be performed in an enclosed system or enclosed gun washer. - closed containers shall be used for disposal and storage of solvent-containing materials used for cleanup. - maintain usage records, along with MSDS, on a daily basis. <p>Polyester Resin Material Operations</p> <ul style="list-style-type: none"> - cleaning material used on lines, rollers, brushes, spray equipment, and personnel and containing > 200 g VOC/L of material as applied (1.7 lb/gal), or where the initial boiling point is less than 190°C (374°F) shall be limited in use to < 57 L (< 15 gal) per calendar week unless a reclamation system is in place. - all materials containing ROC's for cleaning shall be in closed containers. - generate weekly reports that list the manufacturer, product number, amount and application method for each cleaning material used, reclaimed, or recycled.

TABLE B-1. (continued)

State	Cleanup solvent specific regs?	What is regulated?	Specific requirements
California, Ventura County (cont'd)			<p>Motor Vehicle and Mobile Equipment Coating Operations</p> <ul style="list-style-type: none"> - closed containers shall be used to store solvent-containing materials from surface cleanup. Containers shall be nonabsorbent. - Organic compounds will not be used for spray equipment cleanup unless: <ul style="list-style-type: none"> - an enclosed gun washer or low emission spray gun cleaner is used for cleaning. - the composite vapor pressure of organic compounds is < 45 mm Hg (1.8 in. Hg) at 20°C (68°F). - no substrate surface cleaning materials with a ROC content of > 200 g/L (1.7 lb/gal) shall be used. - all ROC-containing materials shall be kept in closed containers when not in use. - MSDS on substrate surface cleaning and application equipment cleaning showing a monthly basis, the following: <ul style="list-style-type: none"> - I.D. of each solvent and its uses. - ROC content of each solvent, gallons per liter. - volume of solvent used; if purchase records are used, then manifests and recycling information should also be maintained. <p><u>Proposed Categories</u></p> <p>Adhesives</p> <ul style="list-style-type: none"> - surface preparation < 200 g/L (1.7 lb/gal). - coating application equipment cleaning: <ul style="list-style-type: none"> - use enclosed gun washer and solvent with vapor pressure < 45 mm Hg (< 1.8 in. Hg). <p>Semiconductor Manufacturing</p> <ul style="list-style-type: none"> - solvent cleaning stations subject to degreasing regs. - surface preparation < 200 g/L (1.7 lb/gal). - coating application equipment cleaning -- use of solvents with a vapor pressure < 33 mm Hg (1.3 in. Hg) at 20°C (68°F).

TABLE B-1. (continued)

State	Cleanup solvent specific regs?	What is regulated?	Specific requirements
California, Ventura County (cont'd)			<p>Rule 66 - Organic Solvents</p> <ul style="list-style-type: none"> - emissions of ROC's to the atmosphere from cleanup with photochemically reactive solvents of any article, machine, equipment, should be included with other emissions of that type of emissions in order to determine compliance. <p>Graphic Arts</p> <ul style="list-style-type: none"> - cleaning operations are limited to: wipe cleaning, remote reservoir cold cleaner, spray bottles with 0.125 L (0.03 gal) or less of solvent applied without propellants or, using a closable solvent container. - maintain daily records showing types of solvents used. Maintain monthly records showing the amount of solvents used and VOC content and density of each. <p>Proposed Rule 317</p> <ul style="list-style-type: none"> - Focus on cleanup solvent substitution and reformulation as a means of reducing ROC emissions. The regulatory alternatives discussed include: <ul style="list-style-type: none"> - closed containers. - vapor pressure limits of not greater than 20 mm Hg (0.79 in. Hg) at 20°C (68°F) and ROC content limits not greater than 200 g ROC/L (1.7 lb/gal) of cleaning solvent. - Prohibit certain cleaning methods: <ul style="list-style-type: none"> - solvent flushing from a solvent container greater than 0.47 L (16 fluid ounces) unless collected in a container. - soaking of objects in a container that is open except when depositing or removing objects. - wipe cleaning where the solvent drips from the material unless collected. - atomizing of solvent into open air. - removing solvent from objects with compressed air.
Colorado, State	No	Cold cleaning and vapor degreasing are regulated.	
Colorado, Denver City/County	NA	NA	NA

TABLE B-1. (continued)

State	Cleanup solvent specific regs?	What is regulated?	Specific requirements
Florida, Jacksonville	No	Cold cleaning and conveyORIZED degreasing are regulated.	The amount and VOC content of each washup solvent.
Georgia, State	No		
Indiana, Evansville	No		
Indiana, State	No	Miscellaneous metal coating	Specific handling methods for any source emitting > 15 lb VOC per day.
Iowa, State	No		
Iowa, Polk County	No		
Kansas, State	Yes	One regulation for miscellaneous metal parts and products and metal furniture and another for lithographic major sources.	<p>Miscellaneous metal parts -- Most facilities with a VOC potential emission rate (including cleaning solvents) equal to or greater than 3 tons/yr shall keep daily records of the type, density, and amount of solvent used for purge and equipment cleaning. Some types of plants are exempt.</p> <p>Lithographic printing -- If employing cleanup solvent containing VOC: the solvent container is tightly covered during transport and storage; cleanup rags used in conjunction with cleanup solvent are placed, when not in use, in tightly closed containers and collected for proper disposal or recycle. Requires that the solvent be extracted from rag before laundering; and monthly records be maintained on the quantity of cleanup solvent used.</p>
Kentucky, State	No	Solvent metal cleaning is regulated.	Maintain daily records of washup solvent used and VOC content of each.
Louisiana, State	No		
Maine, State	No		
Maryland, Baltimore	No		
Michigan, Wayne County	Yes	Paint Manufacturers > 18,900,000 L (500,000 gal) production.	Mixing tanks and paint shipping container cleaning are regulated with limits on VOC content.
Minnesota, State	No		

TABLE B-1. (continued)

State	Cleanup solvent specific regs?	What is regulated?	Specific requirements
Missouri, State	Yes	Lithographic, rotogravure and flexographic printing.	<p>Offset lithographic printing -- If the operation uses cleanup solvents containing VOCs: the cleanup solvents are kept in tightly covered tanks or containers during transport and storage; the cleaning cloths used with the cleanup solvents are placed in tightly closed containers when not in use and while awaiting offsite transportation. The cleaning cloths should be properly cleaned and disposed of; are processed in a way that as much of the solvent as practical is recovered for further use or destroyed. Cleaning and disposal methods shall be approved by the director; and an owner or operator may use an alternate method of reducing cleanup solvent VOC emissions, including the use of low VOC cleanup solvents, if the owner or operator shows that the emission reduction is significant and this method is approved by the director.</p> <p>Recordkeeping -- for each lithographic printing subject to this rule records should be maintained on the quantity of cleanup solvents used on a monthly basis.</p>
Montana, State	No		
Nebraska, State	No		
Nevada, Washoe County	No		
North Carolina, Buncombe County	No		
North Carolina, State	No		
North Carolina, Forsyth County	No		

TABLE B-1. (continued)

State	Cleanup solvent specific regs?	What is regulated?	Specific requirements
Ohio, Dayton	Yes	Organic material emissions from activities using photochemically reactive materials. Cleanup activities are specifically included.	<p>Quantity is restricted as:</p> <p>(1) 6.8 kg (15 lb) of organic compounds per day and 1.4 kg/hr (3 lb/hour) from all operations including cleanup activities from any article, machine, equipment, or other contrivance in which substances which contain liquid organic materials, come into contact with a flame or are baked, heat-cured, or polymerized, in the presence of oxygen, unless said discharge has been reduced by 85%. These limits also apply to non-photochemically reactive materials, including cleanup for sources which include a continuously moving sheet, web, strip, or wire which is subjected to any of the processes or any combination of processes as described above.</p> <p>(2) 18.1 kg/day (40 lb/day); 3.6 kg/hr (8 lb/hr) of organic compounds are limits for emissions, including cleanup, under conditions not described in (1) for employing, evaporating, or drying any photochemically reactive material or substance containing photochemically reactive materials, unless said discharge is reduced by at least 85%. These limits apply to any combination of processes as a continuously moving sheet, web, strip, or wire as described in (1) and (2).</p> <p>There are no recordkeeping requirements.</p>

TABLE B-1. (continued)

State	Cleanup solvent specific regs?	What is regulated?	Specific requirements
Oklahoma, Tulsa City/County	No		
Pennsylvania, Allegheny County	Yes	Emissions of solvents used for cleanup and purging of surface coating operations.	Restrict emissions from surface coating operations to < 1.4 kg/hr (3 lb/hr) or 7 kg/day (15 lb/day). Require daily records of solvent quantity, composition and density, and operating parameters.
Pennsylvania, Philadelphia	No		
Pennsylvania, State	No		
South Carolina, State	No	Cold cleaning, open top vapor degreasing and conveyORIZED degreasing are regulated.	Record nature, specific sources, and total monthly VOC emissions, including cleanup solvent.
Tennessee, Memphis & Shelby County	No		
Tennessee, Metropolitan	Yes	Solvent metal cleaning. Miscellaneous metal parts and products. Special provisions for new VOC sources and modifications.	Require good work practices, the use of solvents that will result in the lowest VOC emissions, and recordkeeping of daily and annual solvent use rates.
Tennessee, State	No		
Vermont, State	No		
Virginia, State	No	ConveyORIZED degreasing, open top vapor degreasing and cold cleaning are regulated.	NA
Washington, Puget Sound	No		

TABLE B-1. (continued)

State	Cleanup solvent specific regs?	What is regulated?	Specific requirements
Wisconsin, State	Yes	<p>Organic compound emissions from activities using organic compounds, solvents, or mixtures. Cleanup solvents are specifically included.</p> <p>Cleaning related to cured and air dried coating operations of miscellaneous metal parts and products is regulated.</p> <p>Cold cleaning, open top vapor degreasing, conveyORIZED vapor degreasing, and conveyORIZED nonvapor degreasing are regulated.</p>	<p>Use of good operating procedures with solvents used in cleanup operations.</p> <p>VOC emissions from solvent washings will be considered in the emission limitations set for cured and air dried coatings unless the used wash solvent is collected in containers that prevent evaporation.</p> <p>Reporting required for facilities with air emissions of ≥ 0.23 Mg/d (0.25 ton/day) or 45 Mg/yr (50 ton/yr) of any one or more primary air contaminants. Daily records for ink, coating, thinning and cleanup solvents contain at minimum daily usage and VOC content of each material.</p>

NA = Not answered

^aNo regulations provided - deferred to South Coast and Bay Area

TABLE B-2. CURRENT PRACTICE

Agency	How air permits include cleaning		VOC Definition used ^a	Aspects of cleaning operations checked during inspection	Plans for future cleaning solvent regulations
	Aggregate w/other sources	Considered separately			
Alabama, Jefferson County	✓	✓	EPA	<ul style="list-style-type: none"> VOC storage areas VOC handling methods Presence of open containers Spill cleanup methods Thinning solvents Equipment cleanup methods Daily records of solvent usage Waste solvent recovery method Final disposal of waste solvent 	None
Alabama, Huntsville	✓		EPA	<ul style="list-style-type: none"> Process operations/procedure Waste stream characteristics Storage/containment of solvent 	Automotive refinishing and restoration rule is in developmental stage
Alabama, State	✓		EPA	NA	None
Arizona, State	✓	✓	Previous EPA (plus methylene chloride)	<ul style="list-style-type: none"> Record of solvent usage VOC quantity emitted, etc. 	<ul style="list-style-type: none"> Permitting requirement for solvent cleaning Standards of performance for solvent cleaning
Arkansas, State	✓	✓	EPA	<ul style="list-style-type: none"> Record of solvent usage 	None

TABLE B-2. (continued)

Agency	How air permits include cleaning		VOC Definition used ^a	Aspects of cleaning operations checked during inspection	Plans for future cleaning solvent regulations
	Aggregate w/other sources	Considered separately			
California, Bay Area	✓	✓	EPA (plus ethane)	<ul style="list-style-type: none"> Look for uncovered rags or paper Open solvent containers Cleaning method for spray equipment Record of solvent usage Solvent storage methods 	<ul style="list-style-type: none"> Planning to set volatility and VOC limits for cleanup solvents with "Substitute Solvents Used for Surface Preparation/Cleanup of Coatings"
California, State	NA	NA	EPA	<ul style="list-style-type: none"> Amount and type of solvent Visually inspect application equipment Methods of cleanup Housekeeping techniques 	<ul style="list-style-type: none"> Guidance document is being developed
California, Lassen County			No specific definition	None	Possible
California, Ventura County	✓		EPA	<ul style="list-style-type: none"> Record of solvent usage Proper storage/disposal VOC (g/L) or vapor pressure limit Permit limits (g/L, type of solvents) 	1/93 general rule to cover all cleanup solvent use not currently addressed
Colorado, State	✓		Previous EPA (are adding additional compounds per EPA)	<ul style="list-style-type: none"> Records of solvent usage Compliance with rules 	None

TABLE B-2. (continued)

Agency	How air permits include cleaning			VOC Definition used ^a	Aspects of cleaning operations checked during inspection	Plans for future cleaning solvent regulations
	Aggregate w/other sources	Considered separately	Not considered			
Colorado, Denver City/County	NA	NA	NA	NA	<ul style="list-style-type: none"> Inventory records for solvent purchased Waste documentation such as manifests and recycling records Housekeeping procedures for storage, use, and disposal of solvents and associated materials 	NA
Florida, Jacksonville			✓	Previous EPA	<ul style="list-style-type: none"> Type of solvents Frequency of usage Duration of usage Quantity Mechanism of application Controls MSDS 	None
Georgia, State	✓			EPA	<ul style="list-style-type: none"> Records of solvent usage Physical evidence of usage 	None
Indiana, Evansville	✓			362 IAC	<ul style="list-style-type: none"> Solvent usage 	NA
Indiana, State	✓	✓ (if specific cleanup equipment is used)		Previous EPA	<ul style="list-style-type: none"> Records of amounts used Area where solvents are used Equipment used for cleanup 	None
Iowa, State				EPA	<ul style="list-style-type: none"> Compliance with permit conditions 	None

TABLE B-2. (continued)

Agency	How air permits include cleaning		VOC Definition used ^a	Aspects of cleaning operations checked during inspection	Plans for future cleaning solvent regulations
	Aggregate w/other sources	Considered separately			
Iowa, Polk County		✓	EPA	<ul style="list-style-type: none"> Recordkeeping report 	None
Kansas, State	✓		Previous EPA	<ul style="list-style-type: none"> Storage Usage Records 	NA
Kentucky, State	✓		EPA	<ul style="list-style-type: none"> Records of raw material usage Records of solvent usage Waste solvent disposal records 	None
Louisiana, State	✓		Previous EPA	<ul style="list-style-type: none"> Records of solvent usage 	None
Maine, State	✓		NA	None	<ul style="list-style-type: none"> Solvent Metal Cleaning regulations will be adopted Nov. 15, 1992
Maryland, Baltimore			Previous EPA	<ul style="list-style-type: none"> Look at all VOC's used at facility 	None
Michigan, Wayne County	✓ (depends on size and type of source)	✓ (depends on size and type of source)	(currently undergoing revision)	NA	Only if State adopts new regulations.
Minnesota, State		✓ (inconsistent)	NA	<ul style="list-style-type: none"> Permit requirements Records of solvent usage 	NA
Missouri, State		✓	Previous EPA	<ul style="list-style-type: none"> Solvent recordkeeping 	None
Montana, State	✓		EPA	Very cursory review	None

TABLE B-2. (continued)

Agency	How air permits include cleaning		VOC Definition used ^a	Aspects of cleaning operations checked during inspection	Plans for future cleaning solvent regulations
	Aggregate w/other sources	Considered separately			
Nebraska, State	✓	✓	NA	Cleaning operations are not generally inspected	None
Nevada, Washoe County	✓		vapor pressure definition of 78 mm Hg (<1.5 lb/in ²)	<ul style="list-style-type: none"> Solvent records MSDS Condition of equipment 	None
North Carolina, Buncombe County	✓		✓ (source dependent)	<ul style="list-style-type: none"> Records - use material balance 	None
North Carolina, State	✓		State	NA	None
North Carolina, Forsyth County	✓		EPA	<ul style="list-style-type: none"> Records of solvent usage 	NA
Ohio, Dayton	✓	✓ (when a facility does inventories by material balance)	Previous EPA	<ul style="list-style-type: none"> Review facility records Work practices Suggestions for minimizing emissions Recommend solvent substitutions 	None
Oklahoma, Tulsa City/County	✓		EPA and vapor pressure definition	<ul style="list-style-type: none"> Check annual Emissions Inventory Maintenance records Applicable equipment 	None
Pennsylvania, Allegheny County	✓		EPA	<ul style="list-style-type: none"> Record of solvent usage 	NA
Pennsylvania, Philadelphia	✓		EPA	<ul style="list-style-type: none"> Records of solvent purchase and usage 	None
Pennsylvania, State	✓		EPA	<ul style="list-style-type: none"> Records to determine compliance w/ permit Operating practices/good housekeeping 	NA

TABLE B-2. (continued)

Agency	How air permits include cleaning		VOC Definition used ^a	Aspects of cleaning operations checked during inspection	Plans for future cleaning solvent regulations
	Aggregate w/other sources	Considered separately			
South Carolina, State		✓	EPA	NA	NA
Tennessee, Metropolitan	✓	✓	EPA	<ul style="list-style-type: none"> Look for good work practice in use and storage Reports of annual emissions including cleanup losses 	None
Tennessee, Memphis and Shelby County	✓		EPA	<ul style="list-style-type: none"> Records of solvent usage 	None
Tennessee, State	✓	✓	EPA	<ul style="list-style-type: none"> Records of solvent usage 	None
Vermont, State	✓		Vapor pressure definition (are proposing EPA definition)	None	None
Virginia, State	✓	✓	EPA	<ul style="list-style-type: none"> Check material balance and other records 	NA
Washington, Puget Sound	✓ (depends on source size)	✓ (depends on source size)	EPA	<ul style="list-style-type: none"> Lids on VOC containers Spray equipment cleaning method 	<ul style="list-style-type: none"> Wood finishing regulations in preliminary development Marine surface coating regulations in preliminary development

TABLE B-2. (continued)

Agency	How air permits include cleaning		VOC Definition used ^a	Aspects of cleaning operations checked during inspection	Plans for future cleaning solvent regulations
	Aggregate w/other sources	Considered separately			
Wisconsin, State	✓ (coating and printing)	✓	Previous EPA	<ul style="list-style-type: none"> • Solvent containers • Dirty rags • Storage • Solvent reclamation 	None

NA = Not answered.
^aEPA: State uses current EPA definition of VOC from FR Vol.57 No. 22 February 3, 1992. Previous EPA: State defines VOC with EPA definition in FR Vol. 56 No. 52 March 18, 1990.

TABLE B-3. SUGGESTIONS AND INFORMATION FOR GUIDANCE ON CLEANUP SOLVENT EMISSION CONTROL TECHNIQUES

Agency	Comments on approach	Unit Operations cleaned at inspected plants	Available emission control case study information	Other information and VOC reduction ideas
Alabama, Jefferson County	<ul style="list-style-type: none"> Address types of painting equipment and paint used 	<ul style="list-style-type: none"> Roll applicators Flood and spray coaters Conveyors for painted products Floor areas 	None	<ul style="list-style-type: none"> Replace cleanup solvents with nonorganic detergents Use pyrolysis to clean parts
Alabama, Huntsville	None	<ul style="list-style-type: none"> Surface preparation Spray painting equipment and spray booths Press cleaning 	None	<ul style="list-style-type: none"> Maintain continuity with fire safety and environmental guidelines such as NFPA^a Guidelines for spray booths and storage of flammables
Alabama, State	None	<ul style="list-style-type: none"> Distillation columns Tanks Spray booths Printing machines Parts cleaners 	None	None
Arizona, State	None	<ul style="list-style-type: none"> Process equipment (molds, containers, etc.) Individual parts cleaning 	Spray painting operation	<ul style="list-style-type: none"> Substitution w/low VOC solvents Use vapor degreasing
Arkansas, State	Should not be too complex to understand	<ul style="list-style-type: none"> Fiberglass boat manufacturer 	Boat manufacturing	<ul style="list-style-type: none"> Ration cleanup solvent to workers Lids on container

TABLE B-3. (continued)

Agency	Comments on approach	Unit Operations cleaned at inspected plants	Available emission control case study information	Other information and VOC reduction ideas
California, Bay Area	<ul style="list-style-type: none"> Approach is practical only if all "acceptable" methods of cleaning are identified and specified Must identify current cleaning methods to develop emission reduction factors Could alternatively identify cleaning methods by source category and identify acceptable cleaning methods for each category 	<ul style="list-style-type: none"> Paint spray guns and components Cold solvent parts cleaners Printing presses General wipe cleaning of work areas, work benches, spray booth filters 	Aerospace industry contact provided	Include methods to clean auxiliary spray application equipment such as supply and distribution lines, large pressure pots, and in-line heating systems
California, State	<ul style="list-style-type: none"> Generalized guidance may not be possible since some sources have specific needs-must provide direction for specific requirements of these sources Allow alternative approaches to be approved via director 	<ul style="list-style-type: none"> Coating applications, manufacturing, and degreasing Surface preparation General maintenance Cleanup operations 	None	None
California, Lassen County	N/A	N/A	None	N/A

TABLE B-3. (continued)

Agency	Comments on approach	Unit Operations cleaned at inspected plants	Available emission control case study information	Other information and VOC reduction ideas
California, Ventura County	<ul style="list-style-type: none"> Wide variety of sources requires special consideration Alkaline cleaners not to be used for cleaning Aluminum Water-based solvent rusts some materials Purity required in electronics industry Should limit all solvent to 200 g/L (1.7 lb/gal) or 10 mm Hg (0.39 in. Hg) at 20°C (68°F) w/specific exemptions 	<ul style="list-style-type: none"> Oilfield equipment (well heads) Engines Rocket engines Spray guns Coating application equipment 	Boat manufacturing article provided	Provided contacts on Technical Review Group Solvents Committee developing BARCT/RAC ^{tb} for "Surface Preparation and Cleanup Solvents"
Colorado, State	None	<ul style="list-style-type: none"> Paint spray guns Printing presses Can coating lines Coating line blades 	None	NA
Colorado, Denver City/County	<ul style="list-style-type: none"> Should state that TCE is not an acceptable substitute for VOC solvents (Many small industries have made this change due to TCA's exemption.) 	NA	NA	NA
Florida, Jacksonville	None	None	None	None
Georgia, State	None	<ul style="list-style-type: none"> Printing press blanket wash Paint spray booth Aircraft stripping 	Provided 2 contacts for automotive spray booth cleaning data	<ul style="list-style-type: none"> Covers for tank cleaning Non-VOC agents for floor cleaning
Indiana, Evansville	NA	NA	NA	NA

TABLE B-3. (continued)

Agency	Comments on approach	Unit Operations cleaned at inspected plants	Available emission control case study information	Other information and VOC reduction ideas
Indiana, State	<ul style="list-style-type: none"> Recordkeeping is burdensome to both company and agency, not easily verified, is easily falsified, and not reliable for compliance Impose State or federal tax on cleanup solvents sold or manufactured as incentive to reduce usage. Then provide information on how sources can reduce emissions 	<ul style="list-style-type: none"> Distillation columns Tanks Spray booths Printing machines Parts cleaners Surface preparation 	None	<ul style="list-style-type: none"> Should be simple and field enforceable Inspectors need to check physical aspects Solvent taxes may be best way to reduce emissions Records are not reliable
Iowa, State	NA	<ul style="list-style-type: none"> Dip tanks Doctor blades Rolls 	None	None
Iowa, Polk County	<ul style="list-style-type: none"> Inclusion of fugitive VOC's in permanent total enclosure capture efficiency calculations motivates limiting usage 		NA	<ul style="list-style-type: none"> Avoid compliance costs of VOC's by using aqueous-based systems
Kansas, State	<ul style="list-style-type: none"> Should address handling and storage of solvents and rags Solvent should be extracted from rags before treating rags 	<ul style="list-style-type: none"> Printing presses 	None	<ul style="list-style-type: none"> MN and TX Air Control Boards have done work with solvent-laden rags
Kentucky, State	<ul style="list-style-type: none"> Should not apply to sources where the State currently includes cleanup as part of source specific RACT or BACT 	<ul style="list-style-type: none"> Chemical reactors Plastic injection molds Paint applicators 	None	None

TABLE B-3. (continued)

Agency	Comments on approach	Unit Operations cleaned at inspected plants	Available emission control case study information	Other information and VOC reduction ideas
Louisiana, State	None	<ul style="list-style-type: none"> • Assembly line operations • Aircraft maintenance • Auto/truck maintenance 	None	None
Maine, State	None	None	None	<ul style="list-style-type: none"> • New source categories are low priority compared with other CAAA requirements
Maryland, Baltimore	<ul style="list-style-type: none"> • Regulations will cover certain generic operations. Industry may have difficulty determining whether their cleaning activity is regulated 	<ul style="list-style-type: none"> • Spray booths • Printing presses 	None	None
Michigan, Wayne County	<ul style="list-style-type: none"> • Possible incompatibility of wipe solvent and surface coating system in automobile assembly 	<ul style="list-style-type: none"> • Paint shipping containers • Spray booths • Vehicle wiping prior to painting 	NA	NA
Minnesota, State	None	N/A	None	NA
Missouri, State	None	<ul style="list-style-type: none"> • Printing facilities • Paint spray booths 	None	None
Montana, State	None	<ul style="list-style-type: none"> • Particleboard finishing/printing line 	None	NA
Nebraska, State	None	<ul style="list-style-type: none"> • Safety Kleen solvent stations • Hand applications 	Example of add-on control (thermal incinerator)	NA
Nevada, Washoe County	N/A	<ul style="list-style-type: none"> • Dip tanks • Printing operations • Spray booths • Mixing operations • Packaging operations • Plastics production 	<ul style="list-style-type: none"> • Add-on control example • Distillation recovery example 	None

TABLE B-3. (continued)

Agency	Comments on approach	Unit Operations cleaned at inspected plants	Available emission control case study information	Other information and VOC reduction ideas
North Carolina, Buncombe County	None	None	None	None
North Carolina, State	<ul style="list-style-type: none"> Reasonable cutoff level to exempt small users 	NA	Provided contact at agency	None
North Carolina, Forsyth County	None	<ul style="list-style-type: none"> Roller and blanket wash Paint spray nozzle Printing press cylinders Parts washers 	None	None
Ohio, Regional	None	<ul style="list-style-type: none"> Grates in painting operations Spray booths Surface preparation for adhesive application. 	NA	<ul style="list-style-type: none"> Small facilities do not account for collected solvent, so that emissions appear to be usage Public relations incentives where facilities that reduce emissions by some percentage are listed as "Clean Facilities"
Oklahoma, Tulsa City/County	<ul style="list-style-type: none"> Should be directed at specific solvents Recordkeeping requirements and methods of controlling emissions should be enforced by State De minimus limits for emissions Define economic impact for affected industries Industry review prior to publication 	None	None	<ul style="list-style-type: none"> De minimus limits based on annual emissions rather than single cleaning event emissions Establish hourly limits to prevent exposure

TABLE B-3. (continued)

Agency	Comments on approach	Unit Operations cleaned at inspected plants	Available emission control case study information	Other information and VOC reduction ideas
Pennsylvania, Allegheny County	<ul style="list-style-type: none"> Specify industry or source category since broad regulations on equipment enclosure, solvent substitution, and work practice impacts a large number of industries 	<ul style="list-style-type: none"> Printing Spray booths Coil coaters Paper coaters Mixing tanks Automobile repairs Laboratories 	None	<ul style="list-style-type: none"> Use of low VOC solvents where feasible Better housekeeping Require solvent collection and recovery in extreme cases Require recordkeeping Charge \$25/ton for unrecovered solvents
Pennsylvania, Philadelphia	None	<ul style="list-style-type: none"> Printing press Coaters Parts cleaners 	Provided contact in shipbuilding industry	None
Pennsylvania, State	<ul style="list-style-type: none"> Generic requirements are better than none. 	NA	NA	NA
South Carolina, State	None	Fiberglass and paint spray gun	NA	NA
Tennessee, Metropolitan	<ul style="list-style-type: none"> Stress solvent substitution Stress work practice 	<ul style="list-style-type: none"> Printing presses Painting equipment Paint manufacturing Boat manufacturing Misc. boat manufacturing 	None	None
Tennessee, Memphis and Shelby County	<ul style="list-style-type: none"> Most of the agency's cleanup solvent sources are small businesses Equipment changes present financial burden for these firms Solvent substitution and work practice are more useful 	<ul style="list-style-type: none"> Printing presses Automobile/truck servicing shops Spray booth Paper making machines Wipe operations 	None	None
Tennessee, State	None	None	None	None

TABLE B-3. (continued)

Agency	Comments on approach	Unit Operations cleaned at inspected plants	Available emission control case study information	Other information and VOC reduction ideas
Vermont, State	NA	<ul style="list-style-type: none"> • Printers • Dip cleaning of plating materials • Coating equipment 	NA	NA
Virginia, State	NA	<ul style="list-style-type: none"> • Spray booths • Printing machines • Parts cleaners 	None	None

TABLE B-3. (continued)

Agency	Comments on approach	Unit Operations cleaned at inspected plants	Available emission control case study information	Other information and VOC reduction ideas
Washington, Puget Sound	<ul style="list-style-type: none"> • Military and commercial aircraft specifications limit solvent choices • List specific source categories • Include problems encountered and specific successes achieved in these categories • Case study information is helpful 	<ul style="list-style-type: none"> • Spray guns • Spray booth • Foam manufacturing • Paint and ink manufacturing • Mixing vats 	<ul style="list-style-type: none"> • Will provide aerospace and boatbuilding contacts • Provided contact for WA department which assists facilities in reducing hazardous waste 	<ul style="list-style-type: none"> • Emphasize case studies • Work with industries
Wisconsin, State	None	None	None	None

^aNational Fire Protection Association.

^bBest available retrofit control technology/reasonably available control technology.

^cBest available control technology.

B.3 REFERENCES FOR APPENDIX B

1. Jefferson County Department of Health. Section 8.11.12.
2. City of Huntsville, Alabama. Air Pollution Control Rules and Regulations. Department of Natural Resources and Environmental Management. Ch.8, 8.11.12(a)(3). April 1992.
3. Arizona Department of Environmental Quality. Arizona Administrative Code, Title 18, Chapter 2, R18-2-530.
4. Bay Area Air Quality Management District. Regulation 8: Organic Compounds. 8-1-300, -320, -321, -322. May 1988.
5. South Coast Air Quality Management District. Staff Report for Rule 1171: Solvent Cleaning Operations. SCAQMD No. 910626MG. June 1991.
6. Ventura County Air Pollution Control District. Summary of Cleaning Solvent Regulations.
7. Air Pollution Control Section. Kansas Department of Health and Environment, Proposed New Regulation No. 28-19-76. June 1991.
8. Air Pollution Control Division. Wayne County Health Department. Michigan Department of Natural Resources. Rule 630.
9. Air Conservation Commission. Code of State Regulations. Department of Natural Resources. 10 CSR 10-2.340, 10-2.290. March 1992.
10. Regional Air Pollution Control Agency. Regulation No. 3745-21-07(G)4.
11. Bureau of Air Pollution Control. Allegheny County Health Department. Section 505.
12. Metropolitan Health Department. Pollution Control Division. Sections 7-14(c)(6), 7-16(f), and 7-23.
13. Wisconsin Department of Natural Resources. Section NR 419.03(2), NR 101.21(4), NR 101.22(3), NR 422.15(8), Wisconsin Administrative Code.

APPENDIX C.

APPENDIX C.

C.1 UNIT OPERATION APPROACH

Cleaning with solvents in an industrial setting may be perceived on a unit-operation basis.¹⁻⁴ The conventional unit operation, a term common to the chemical engineering discipline, is an industrial operation classified or grouped according to its function in an operating environment. Unit operations vary considerably among industries. Examples include items of traditional production equipment such as a distillation column, a paint mixing vessel (tank), or a printing machine. Other less traditional examples could be defined as areas in which manufactured parts are handled or cleaned, a spray booth, or a parts cleaner.

A manufactured product may require cleaning to prepare it for a subsequent manufacturing step. An example is to remove contaminants from a primed car body prior to topcoating. A high standard of cleanliness is required both to ensure proper adhesion of the coating and to remove any contaminant that would signal its presence through the paint, resulting in a blemish or unevenness.

In some cases, unit operations are production equipment that must be cleaned to avoid contamination between different batches of material manufactured using the same equipment. Cleaning mixing vessels between batches of different adhesive compounds is an example. Another is solvent purging of spray guns and associated hoses between color changes. Cleaning production equipment or work areas is also done to maintain equipment and provide clean working environments for employees.

Data were solicited from the focus industries based on a material balance around a unit operation system (UOS). For purposes of material balance calculations, the concept of the unit operation "system" extends the boundaries of the conventional "unit operation". The UOS is defined as the ensemble around which a material balance for cleaning can be performed. The boundaries of a UOS should be selected to include all possible points/sources leading to evaporative emission losses associated with cleaning a specific unit operation, including losses during dispensing the solvent, spilling virgin and used solvent, handling residual solvent in cleaning applicators, etc. Emissions from waste management (e.g., recycling or subsequent treatment) are not to be included within a UOS.

A material balance is a mathematical statement that expresses the law of conservation of mass (i.e., at equilibrium, the mass that flows into a process or UOS equals the mass out). It can be used to calculate the quantity or composition of one stream when all others flowing in and out of the UOS are known. For this study, material balances are written for the VOC-containing solvents used within a UOS. In many cases, the unknown "stream" is the cumulative emissions from within the UOS. The material balance can quantify this total.

An example of a unit operation system for a "wiping-cleaning" activity is provided in Figure C-1. Whereas a conventional material balance around this unit operation might attempt to limit an evaluation of Streams A and B (see small box within Figure C-1), the "system" concept is more pragmatic. It incorporates any inefficiencies (additional evaporative losses) that precede or follow the unit operation but would not have happened were it not for the activity at the unit operation. The "system" encompasses the virgin solvent container, the cleaning applicators (rags), the unit operation being cleaned, the spent solvent remaining in the virgin solvent container (dirtied from dipping the rag in the container), and the container for used cleaning applicators. Note that the UOS encompasses the entire

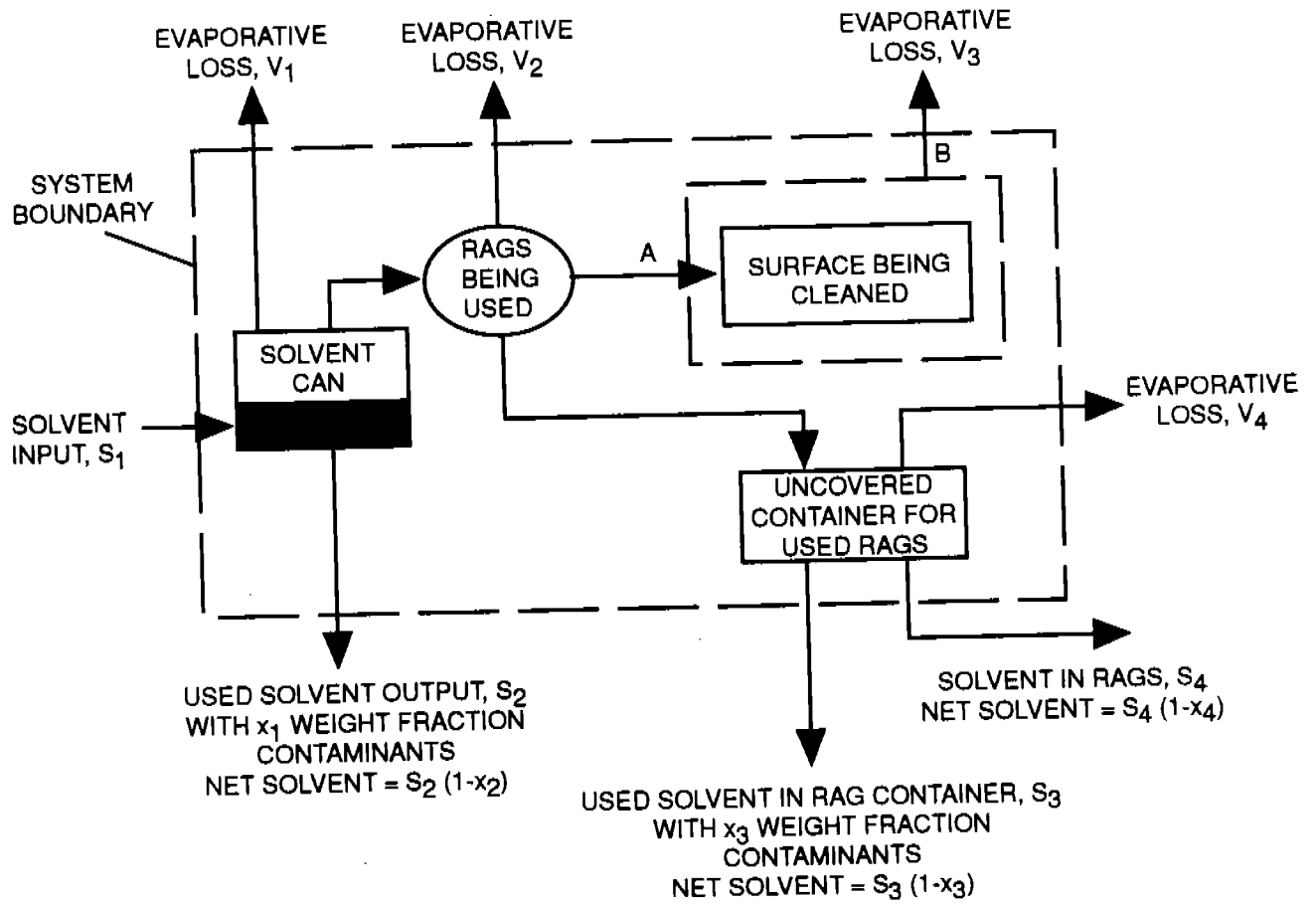

Figure C-1. Example unit operation system (uncontrolled).

path of the solvent from the time it leaves a controlled environment (closed vessel) until it is physically removed (e.g., taken offsite for disposal or removed from storage for reuse onsite). The following equation represents the VOC material balance for the UOS in Figure C-1:

$$V_1 + V_2 + V_3 + V_4 = S_1f_1 - S_2f_2(1-X_2) - S_3f_3(1-X_3) - S_4f_4(1-X_4)$$

where:

- $V_1, V_2, V_3,$ and V_4 = VOC emissions, lb/yr;
- $S_1, S_2, S_3,$ and S_4 = Solvent streams, lb/yr;
- $f_1, f_2, f_3,$ and f_4 = VOC weight fraction in solvent, lb VOC/lb solvent; and
- x_1, x_2, x_3 and x_4 = Contaminant weight fraction in spent solvent, lb contaminant/lb waste.

Completion of the material balance around a UOS requires measurement (or estimates) of all input and output VOC-based liquid solvent streams. The difference between these streams, (after accounting for the contaminants and the VOC content of the solvent), may be assumed to have evaporated as solvent emissions. In the example of Figure C-1, there is one input stream, S_1 , into the UOS. If the solvent is not 100 percent VOC, the total solvent input must be multiplied by the solvent's VOC weight fraction.

Material balances around a UOS should be applied with care to obtain precise and accurate emission estimates. In general, the more complex the UOS the more difficult it is to obtain precise answers. Simpler UOS's will have fewer, more easily measured input and output streams. Another factor that may affect the precision of the emission estimates is the time frame over which data are collected and averaged. Longer term tests generally have more precision. In the example of Figure C-1, an annual basis is used.

There are seven output streams in the example of Figure C-1; three are solvent and four are gaseous. The three output solvent

streams, S_2 , S_3 , and S_4 , represent collection of liquids from the system. The S_2 stream is the amount of solvent remaining in the solvent container; S_3 and S_4 are, respectively, any solvent accumulated in the container that houses used cleaning applicators and the solvent remaining in the cleaning applicators. In some cases, S_3 and S_4 may be zero because the container permits it all to evaporate before it can be reclaimed, recycled, or disposed.

These solvent streams likely contain contaminants, a consequence of cleaning. Contaminant removed from a cleaning applicator may be introduced into the solvent container if the applicator (rag) is dipped. Contaminant levels in the output streams include the weight fractions in the spent solvent (x_1), in the applicators (x_2), in any container used for the soiled applicators (x_3), and contaminants in cleaning applicators (x_4). Knowledge of these contaminant levels may be necessary to determine the mass of solvent in the waste stream. This could be an essential interim step to accurately determine the total VOC-based solvent that evaporated during cleaning. If compensation is not made for the contaminant level, estimates of emission levels will be biased low. The output solvent streams would be assumed to be all solvent, thereby inflating the discharge value.

In this UOS, contamination of S_2 can be eliminated if solvent is dispensed onto the applicator, rather than dipping the applicator into the solvent. That is, the contaminant level in the virgin solvent container will remain zero. For UOS's that include flushing, purging, spraying, or dipping, contamination of the solvent is unavoidable because it occurs by direct contact of solvent with the contaminant on the surface of the unit operation.

The VOC content of the liquid fraction of the spent solvent may need to be determined in cases where input solvents consist of mixtures of VOC's and non-VOC's. In cases where solvent volatility is low (where evaporation losses are not significant), a practical approximation is to assume that the VOC weight

fraction in each spent solvent stream (after correcting for contaminant) is the same as that in the input solvent (i.e., f_1 , f_2 , f_3 , and f_4 are equal).

The gaseous output streams from the cleaning shown in Figure C-1 include evaporative losses from the solvent container, the cleaning applicators, the surface being cleaned, and the spent solvent container. Other emission streams may exist, not shown here, such as evaporation from virgin and spent solvent storage vessels. These should also be attributed to the UOS.

Another factor to consider in some UOS's is process solvent that is collected with spent cleaning solvent. For example, paint in a spray gun contains thinning solvent, a process-derived VOC. Spent solvent collected from cleaning the spray gun includes both process and cleaning solvent. Therefore, a rigorous material balance would require correction for the amount of process solvent associated with the paint in the gun. This amount may be estimated based on knowledge of the solids (contaminant) content in the spent solvent and the solids (nonvolatile matter) content in the purchased paint. See Appendix G for additional details.

In response to EPA's information request, companies identified the unit operations that they clean and defined UOS's for each. They then performed a material balance to calculate the emission rate for each UOS. The variety of systems submitted by the surveyed plants in the focus industries were found to be of nine distinctively different types of UOS's (although there may be subcategories within some). The nine, listed and explained below are believed to be representative of most solvent cleaning performed by all industry:

1. Spray gun cleaning includes spray guns, attached paint lines, and any other gun equipment used in applying a coating;
2. Spray booth cleaning includes all interior surfaces of booths and all equipment within the booth such as conveyors, robots, etc.;
3. Large manufactured components cleaning (i.e., the cleaning of large parts as a step in the manufacture process)

includes large manufactured products, such as automobile bodies, furniture sheet metal, etc.;

4. Equipment cleaning includes all production equipment that may be cleaned in place (not moved to a cleaning area) to prevent cross-contamination or merely for maintenance purposes. Examples are punch presses, electrical contacts on a major piece of equipment, pump parts, packaging equipment, rollers, ink pans, carts, press frames, and table tops;

5. Floor cleaning includes floors in all production areas of a facility;

6. Line cleaning includes lines that transport raw material (e.g., paint, resin) and that are cleaned separately from tanks, spray guns, and other process equipment. In some cases a small tank may be part of the system;

7. Parts cleaning includes miscellaneous items that might be moved to dip into a container of solvent. Examples of parts include applicator tips, brushes, machine parts, pumps, circuit boards, truck parts, engine blocks, gauges, cutoff steel/machined parts, tool dies, motors and assemblies, screws, oil guns, welded parts, bearings, and filters;

8. Tank cleaning includes mixing pots, process vessels, and tanks. In some instances, tank lines are cleaned in conjunction with the tanks and would be considered part of the system; and

9. Small manufactured components cleaning (i.e., the cleaning of small parts as a step in the manufacture process) includes small manufactured products such as glass windows, engine components, subassemblies, sheet metal panels, molded parts, electrical contacts, steel and copper components, tin/silver-plated terminals, plastic parts, upholstered parts, circuit breaker cases, switch covers, and threads and bolts.

These nine types of UOS's provide a framework for describing and understanding cleaning. They were selected based on differences in the level of cleanliness required, method of cleaning, type of contaminants removed, size and use of the item being cleaned, and types of solvents used. In some cases it also may be possible to define subcategories within a given UOS

category; for example, several spray gun cleaning subcategories are discussed in Chapter 4.

The large and small manufactured components and equipment UOS's share a number of similarities. They were developed as three separate categories because of the following differences. First, the data from surveyed plants revealed different reasons for cleaning. Large components were typically cleaned in preparation for painting. Smaller components tended to be more complex shapes and were cleaned as part of a product-assembly process. Equipment was cleaned for maintenance and to provide a safe workplace.

Second, although the data from the surveyed plants did not show a difference, it was initially believed that equipment would more likely be cleaned to remove oil, grease, and dirt, whereas manufactured components would more likely be cleaned to remove glue, wax, markings, and other production-related contaminants. A specific size cutoff between large and small manufactured components was not established, but it was roughly based on whether the component could be moved by an individual.

Tank and line UOS's are similar in that both may consist of a tank and process lines. The tank UOS, however, is perceived as having only a short amount of piping that is cleaned with the tank so that the majority of surface area cleaned is in the tank. Conversely, the line UOS consists of an extensive piping network that may also include a tank; the majority of the surface area cleaned is in the lines.

C.2 UNIT OPERATION SYSTEM DESCRIPTIONS

Figures C-2 through C-10 and their accompanying narratives provide detailed information for the nine UOS's developed from responses to the Agency's request. The diagrams provide a pictorial presentation of the components and boundaries of each UOS. The narratives each explain industrial application, frequency and purpose of cleaning, emission points, and common solvents used within the system.

Equipment Cleaning Unit Operation System

Equipment (rollers, pumps, coaters, paint buckets, machines, conveyors, screw bowl machines, bearings, packaging machines, punch press, electrical contacts, ink templates, etc.) is primarily cleaned with some type of applicator and solvent. Due to the varying nature of equipment, the solvent can be applied in many different ways. However, an applicator is commonly used to spread the solvent and wipe the surface clean. The applicator is usually dipped into the solvent, applied to the equipment, wrung, and stored in barrels before being sent offsite. The type of contaminants removed are gelatin, small particles, ink, dirt, grease, paint, and wax. Emission sources include the solvent container, the soaked applicator, the equipment while being cleaned, and the final storage container, where the applicator may be air-dried. Ethanol, isopropyl alcohol (IPA), butyl acetate, propane, isobutane, butane, cyclohexane, naphthalene, toluene, acetone, xylene, and ethyl acetate are frequently used solvents for equipment cleaning, as seen in the focus industries.

Any equipment parts that are cleaned in a dedicated cleaning vessel are classified in the parts UOS.

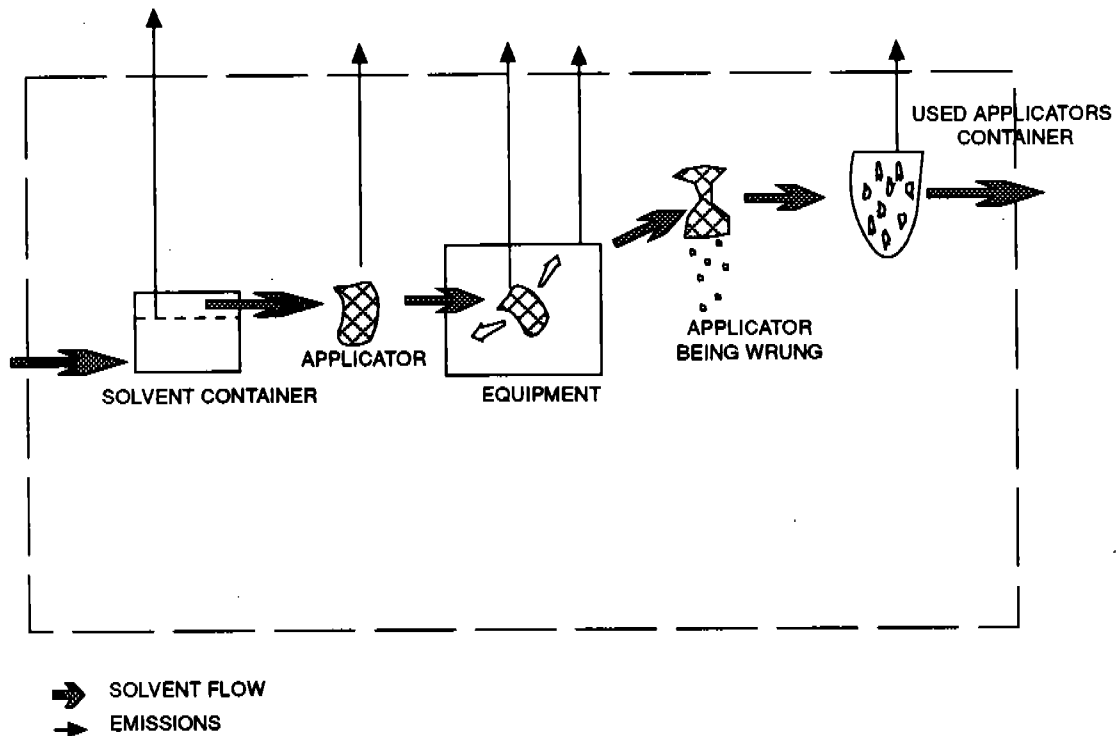

Figure C-2. Equipment cleaning unit operation system.

Floor Cleaning Unit Operation System

The floor cleaning UOS consists of a solvent container, an applicator (e.g., mop, rag), a floor surface, a used applicator storage container, and a dirty solvent collection container. Routine floor cleaning is conducted to remove paint, grease, oil, and grime. The frequency of cleaning ranges from once a week to five times a day. Emission points include the open solvent container, the applicator while in use, the floor after solvent is applied, the used applicator storage container, and the solvent collection container. Typical solvents used to clean floors include acetone, methyl ethyl ketone (MEK), and ethyl acetate.

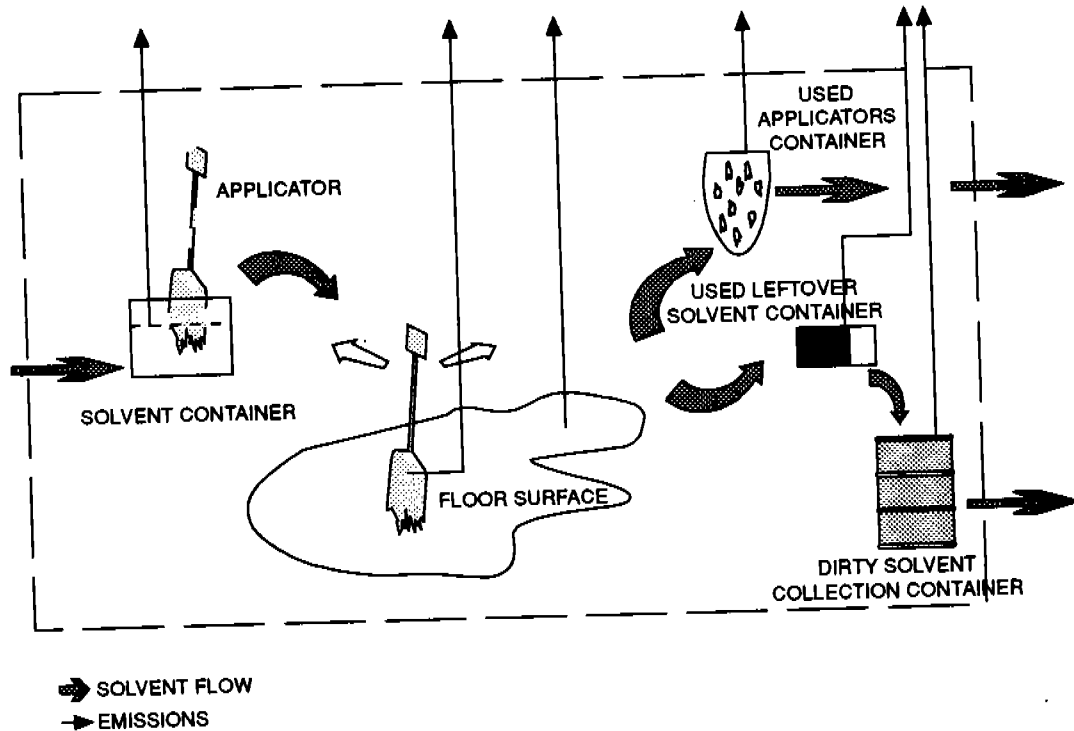

Figure C-3. Floor cleaning unit operation system.

Large Manufactured Components Unit Operation System

Large manufactured components (e.g., auto bodies, furniture components, and sheet metal prior to stamping processes) are cleaned during manufacture using a solvent container and an applicator (brush or paper towel). These components are cleaned to prepare the surface for future treatment by removing grease, oil, grime, dye, polyurethane and polysulfide sealants, and adhesives. Emission sources are the solvent container, the applicator, the component, and the spent applicator. Commonly used solvents include xylene, IPA, naphthalene, MEK, and acetone.

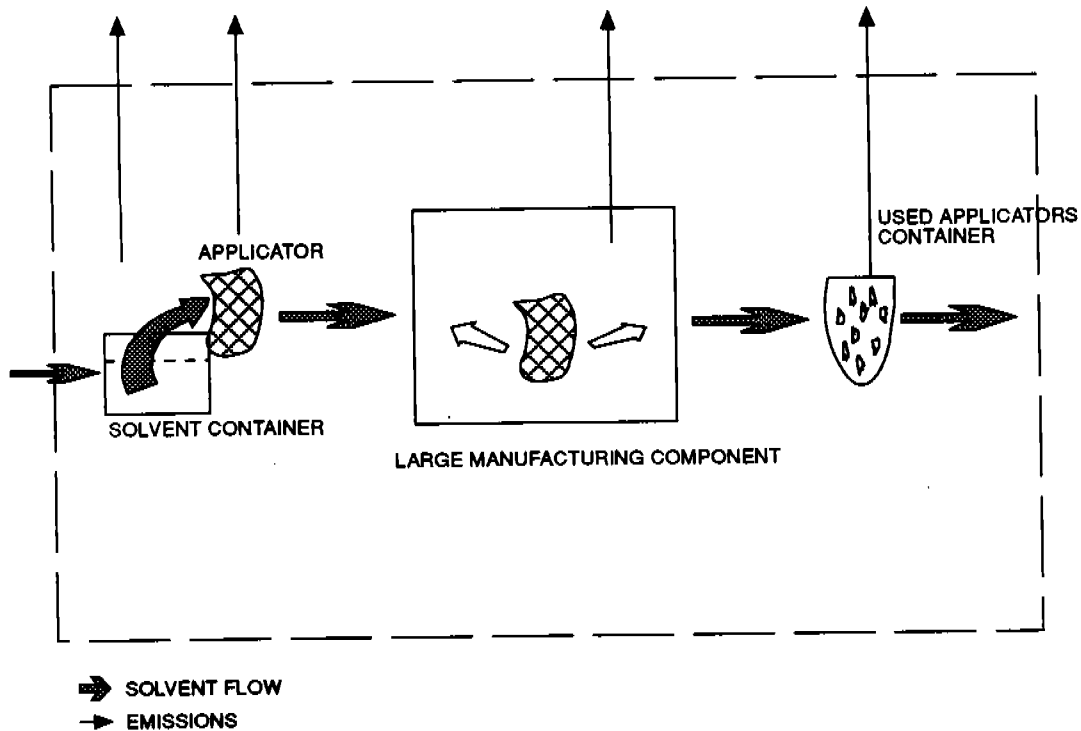

Figure C-4. Large manufactured components unit operation system.

Small Manufactured Components Unit Operation System

Small manufactured components (e.g., contacts, switches, machined parts, and circuit breaker cases) are cleaned during manufacture by applying the solvent from a solvent container onto an applicator and wiping the unit. Small components have contaminants similar to the large manufacturing components. Emission points include the solvent container, the applicator, the manufacturing component, and the used applicator storage container. Acetone, xylene, toluene, ethanol, IPA, and butyl acetate are commonly used to clean small manufactured components.

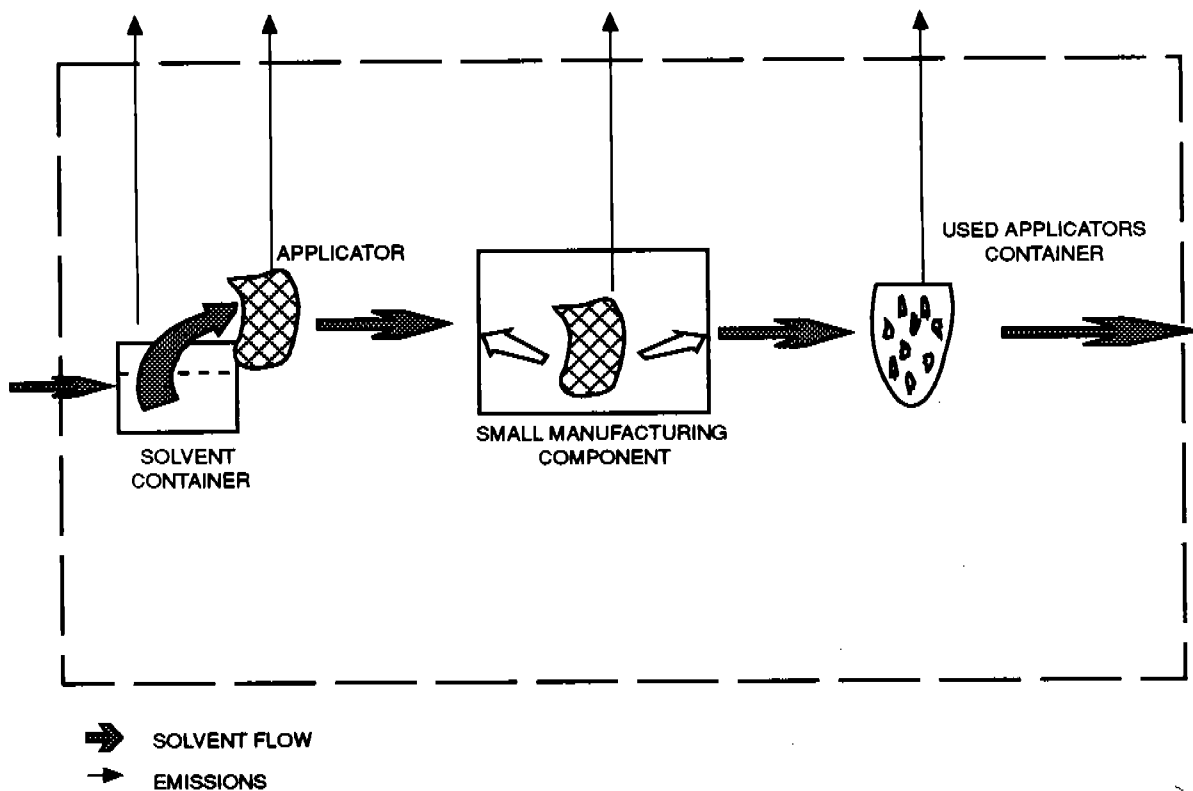

Figure C-5. Small manufactured components unit operation system.

Line Cleaning Unit Operation System

The lines unit operation consists of a line alone or an extensive network of piping with a tank. Lines and associated tanks are cleaned to remove contaminants, typically paint or other coatings, between batches or for maintenance. The solvent is flushed through the tank and lines and sent to the spent solvent container, and the spent solvent is then disposed of or recycled. Emission points are the solvent container, tank, line fittings, and spent solvent container. Xylene, butyl acetate, ethyl benzene, toluene, tetrahydrofuran, cyclohexanone, and MEK are often used to perform this task.

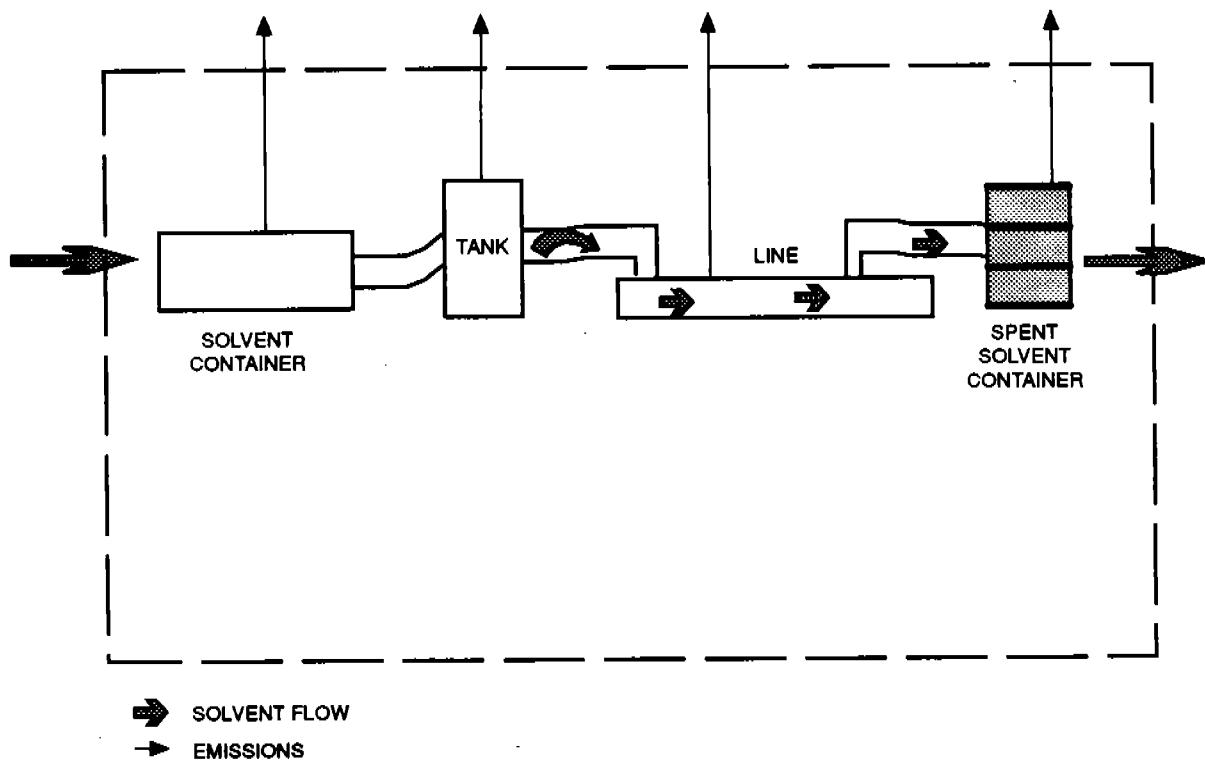

Figure C-6. Line cleaning unit operation system.

Spray Booth Cleaning Unit Operation System

The solvent is typically applied by spraying or wiping the surfaces within the spray booth (e.g., spray booth walls, conveyors, floor, and grating). After application, the solvent is wiped with an applicator (brush or rag). The applicator is usually stored after use in a plastic sealed drum and sent offsite. Emission sources are the solvent containers, the applicator, surfaces in the booth, and the used applicator container. Many different solvents are used for this operation, and the solvent choice depends on the industry. Common choices include mineral spirits, toluene, acetone, xylene, IPA, ethyl glycol butyl ether, and diisopropylene glycol monoethyl ether.

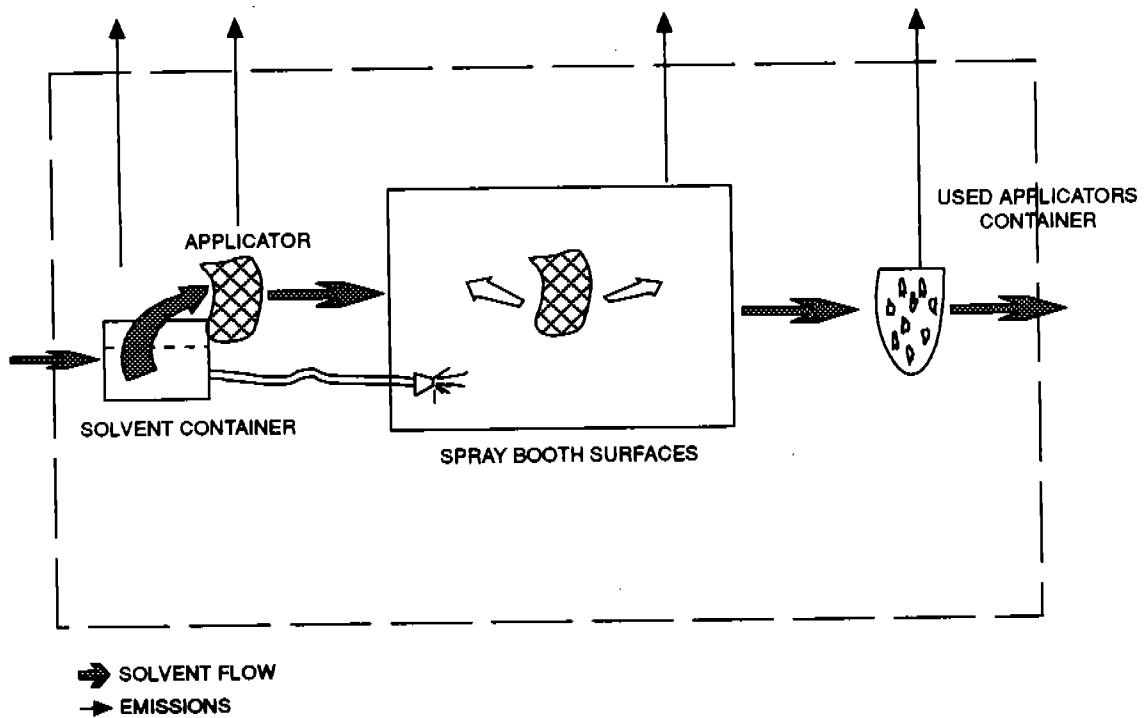

Figure C-7. Spray booth cleaning unit operation system.

Spray Gun Cleaning Unit Operation System

The spray gun cleaning unit operation system consists of a solvent container, a solvent transfer container, the spray gun, attached lines that are cleaned with the gun, possibly a paint collection vat, and a spent solvent collection container. Spray guns are typically used by industries that paint as part of their manufacturing process. The frequency of cleanings is based on the industry's need to change paints. Every time a new color or type of paint is used, the gun has to be cleaned. Some industries use spray guns to apply oil as well. In some instances, the gun is purged into a sink in or near the spray booth and the dirty solvent is drained to the spent solvent container. Emission points include the solvent container, the transfer container, the gun, the spent solvent transfer unit, and the spent solvent storage containers. Xylene, MEK, lacquer thinner, diethylene glycol monobutyl ether, acetone, acetic acid, naphthalene, methyl benzene, ethyl benzene, butyl acetate, methyl isobutyl ketone (MIBK), or methanol are frequently used solvents for this operation, as seen at plants in the focus industries.

The diagram below shows manual cleaning in which all spent solvent is discharged through the nozzle; the solvent that does not evaporate in this process is collected. Different procedures are used for cleaning automated spray equipment: solvent is introduced directly into the paint line, and most of the used solvent is drained from the base of the gun to a spent solvent storage tank or recirculated to the feed tank. Only a short burst through the gun tube and nozzle is discharged to the atmosphere, and this discharge is allowed to evaporate.

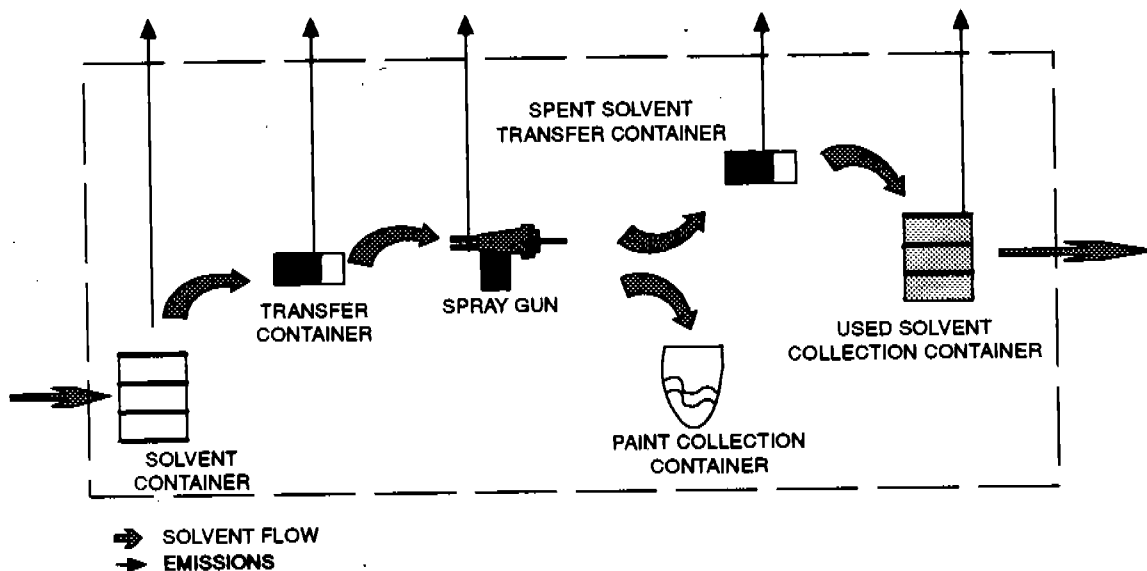

Figure C-8. Spray gun cleaning unit operation system.

Tank Cleaning Unit Operation System

The tanks UOS consists of a tank or reactor vessel alone or with a small amount of attached piping that is cleaned with the tank. Solvent is poured into the tank, and the tank is wiped with an abrasive tool (a brush). The spent solvent is generally used to flush short chemical lines and is then disposed of. Tanks are cleaned to remove residues, grease, and sludge bottoms. The emission sources include the pouring operation, the used brush or rag, and the solvent evaporating from the tank. Commonly used solvents for tank cleaning by plants in the focus industries include ethanol, MEK, acetic acid, naphthalene, ethyl benzene, methyl benzene, MIBK, xylene, cyclohexanone, tetrahydrofuran, toluene, and ethyl acetate.

In some cases, tanks are cleaned without manual scrubbing. Tanks can also be cleaned either manually by spraying the interior surfaces with the lid opened or automatically with the tank lid closed. A spray arm is lowered into the tank, the tank lid is closed, and solvent is sprayed on the interior tank surfaces.

At some facilities, a combination of the above cleaning methods is used.

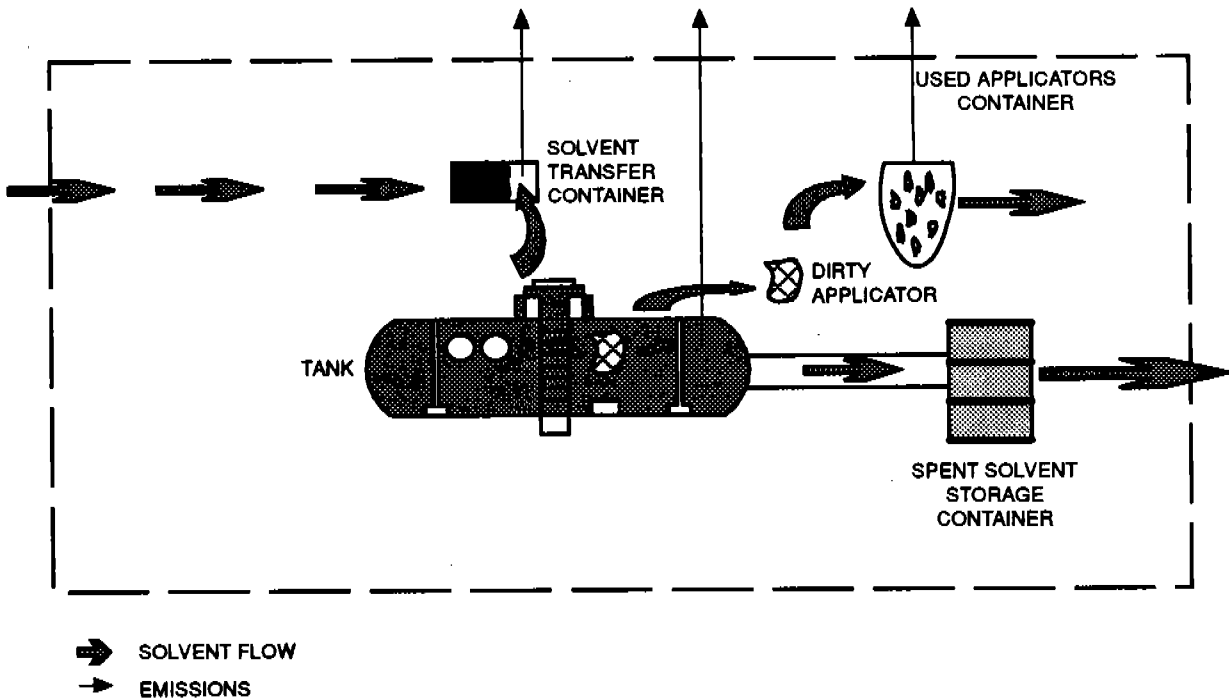
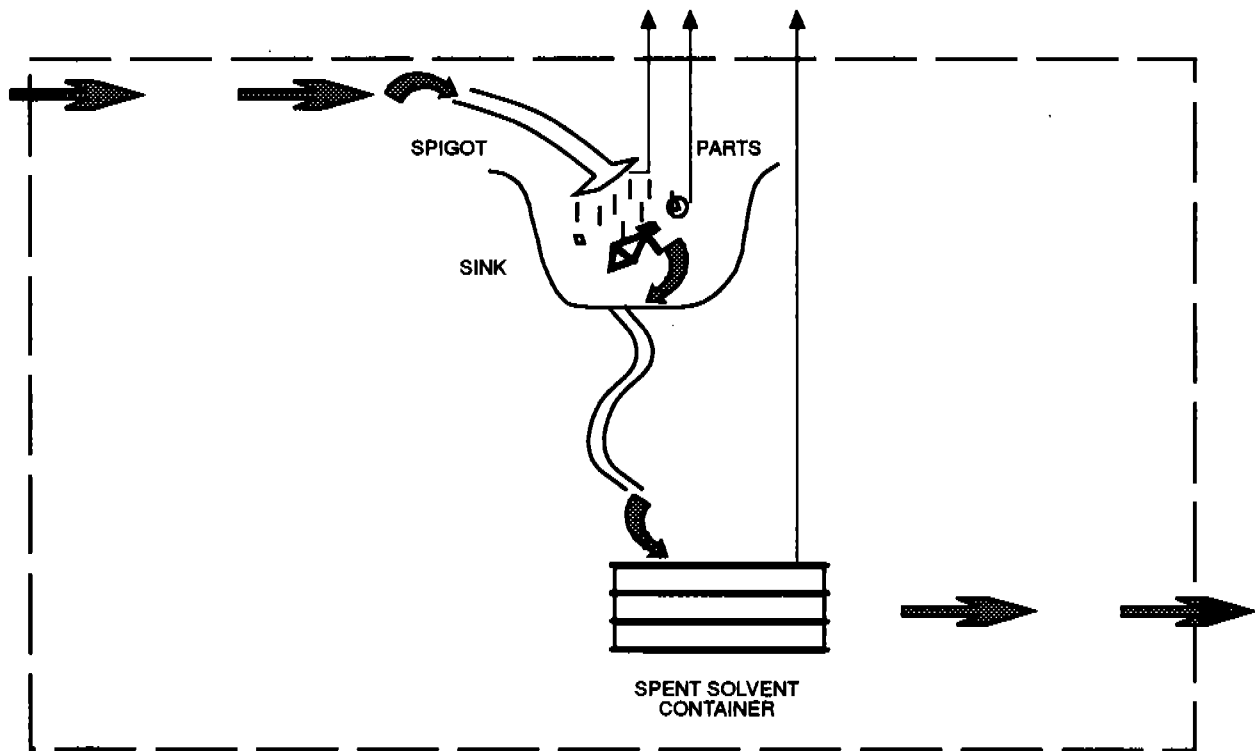

Figure C-9. Tank cleaning unit operation system.

Parts Cleaning Unit Operation System

There are many varied ways of cleaning parts. The most common means of cleaning parts is to put them in a sink and spray solvents from a spigot on the parts. The solvent then drains back to a storage container to be reused later. Another method of cleaning parts is to dip the parts into solvent contained in a sink or bucket. The contaminants of interest are grime, grease, paint, wax, ink, etc. In both methods, there are potential emissions from the solvent application, the part, and the spent solvent storage container. Parts commonly cleaned in this manner include filters, tools, punch press dies, paint brushes, and spray gun tips. Naphthalene, MEK, toluene, ethyl benzene, xylene, IPA, kerosene, tetrahydrofuran, MIBK, cyclohexanone, and ethyl acetate are often used to clean parts.

In some cases, a machine similar to a dishwasher is used. The contaminated part is placed in the machine, the cover is closed, spray nozzles introduce solvent into the machine, and the dirty solvent is piped into a storage or waste tank. An air pollution control device is often attached to the unit to control air emissions.¹⁹ The entire operation is a closed loop. From such equipment, emissions are greatly reduced.



- ➔ SOLVENT FLOW
- ➔ EMISSIONS

Figure C-10. Parts cleaning unit operation system.

C.3 REFERENCES FOR APPENDIX C

1. Serageldin, M. A. Information Requested from Manufacturers. U. S. Environmental Protection Agency, Research Triangle Park, NC. October 16, 1991.
2. Serageldin, M. A., J. C. Berry, and D. I. Salman. A Novel Approach for Gathering Data on Solvent Cleaning. U. S. Environmental Protection Agency. Research Triangle Park, NC. Publication No. EPA/600/R-92/131. May 1992. 7 pp.
3. Memorandum from Serageldin, M.A. EPA/CPB, to Trenholm, A., MRI. September 30, 1992. List of definitions for the Industrial Cleanup Solvent CTG.
4. Serageldin, M.A., "The Unit Operation System--A New Solvent Management System." U. S. Environmental Protection Agency APTI Course No. 582: Issues Related to VOC Control Systems Teleconference Workshop. July 22-23, 1993 (North Carolina State University, Environmental Program -IES).

APPENDIX D.

AMERICAN AUTOMOBILE MANUFACTURERS ASSOCIATION (AAMA) PROPOSAL

Motor Vehicle Manufacturers Association
of the United States, Inc.

October 2, 1992

Thomas H. Hanna
President and Chief Executive Officer

Mr. James C. Berry, Chief
Chemical Application Section
Chemicals and Petroleum Branch
Emission Standards Division
U.S. Environmental Protection Agency
Office of Air Quality Planning and Standards
Research Triangle Park, North Carolina 27711

Dear Mr. Berry:

This letter is a followup to our meeting on August 26, 1992 when we discussed an Engineering Project Study related to the current Environmental Protection Agency (EPA) effort to prepare a Cleanup Solvent Control Technology Guideline (CTG). The enclosed proposal has been prepared along the lines discussed.

It is proposed that the enclosed study procedure be incorporated into the draft CTG. The Motor Vehicle Manufacturers Association of the United States, Inc. (MVMA) is proposing this study in lieu of detailed recordkeeping and reporting procedures under consideration by EPA. Requiring detailed records for individual point sources (i.e., a topcoat booth) on a routine basis would not be cost effective, and potentially would provide inaccurate data. The added cost resulting from such inappropriate requirements for detailed records is not justified and runs counter to one of the objectives of the Clean Air Act -- to promote the productive capacity of the Nation. The MVMA approach will identify opportunities for potential recordkeeping control points unique to each plant and its capabilities and will result in appropriate emission reductions.

As you know, our members are not in the business of performing CTG studies but they do know a lot about cleanup solvents and how to best evaluate their usage in a production environment. Please contact me with any questions or discussion points you may have. We will be interested in learning of your reaction to this proposal.

Sincerely,



E. A. Praschan
Manager, Emissions & Control

Enclosure

A PROJECT STUDY PROPOSAL
ON
CLEANUP SOLVENT USE
IN
MOTOR VEHICLE MANUFACTURING ASSEMBLY OPERATIONS

For
A CONTROL TECHNOLOGY GUIDELINE (CTG)
The Environmental Protection Agency (EPA)

October 2, 1992

Submitted By
The Motor Vehicle Manufacturers Association of the United States, Inc.
7430 Second Avenue, Suite 300
Detroit, Michigan 48202

A PROJECT STUDY PROPOSAL
ON
CLEANUP SOLVENT USE
IN
MOTOR VEHICLE MANUFACTURING ASSEMBLY OPERATIONS

This is an Engineering Project Study Proposal on Cleanup Solvent usage and control in motor vehicle manufacturing assembly operations. It is intended that this study be incorporated into the Control Technology Guideline (CTG) on Cleanup Solvent now being addressed by the Environmental Protection Agency (EPA). The study could be performed either by individual company and plant personnel or in cooperation with an outside contractor.

The study would be done in lieu of detailed recordkeeping and reporting procedures under consideration by EPA. The MVMA approach will identify potential recordkeeping control points in addition to identifying appropriate emission reductions. Containing the impact of inappropriate recordkeeping and reporting will help to balance two key Clean Air Act goals – to protect and enhance air quality and to promote the Nation's productive capacity.

Applicability

The 1990 Clean Air Act (CAA) Amendments require that State Implementation Plans (SIPs) for certain ozone nonattainment areas be revised to require the implementation of Reasonably Available Control Technology (RACT). EPA, in the Federal Register notice 44 FR 53761 (September 17, 1979), defines RACT as: "the lowest emission limitation that a particular source is capable of meeting by the application of control technology that is reasonably available considering technological and economic feasibility." RACT is to be used to control volatile organic compound (VOC) emissions from sources for which the EPA has already published, or is required to publish a CTG.

A CTG for Cleanup Solvents is one of eleven CTG's that EPA must publish within three years of enactment of the 1990 CAA Amendments, i.e., by November 15, 1993. It will identify RACT for control of VOC emissions generated from cleaning solvents used in manufacturing assembly operations. The CTG's are intended to provide State and local air

pollution authorities with an information base for proceeding with their own analyses of RACT to meet statutory requirements. The CTG's review current knowledge and data concerning the technology and costs of various emission control techniques. Each CTG contains a "presumptive norm" for RACT for a specific source category, based on EPA's evaluation of the capabilities and problems general to that category. Where applicable, EPA recommends that States adopt requirements consistent with the presumptive norm.

Consequently, it is appropriate that the draft CTG provide guidance on studies of cleanup solvent operations in existing plants and that the studies identify those capabilities, problems, concerns and any potential exemptions or de minimis levels considered appropriate for cleanup solvent usage in RACT plants.

Description of Plan

The study would identify sources and usage of cleanup solvent through a comprehensive (suggest minimum of three months) review of purchase records, plant distribution sources, identifiable cleanup operations, and recycling and waste disposal records where quantities are justified. The study would also identify potential VOC usage reductions at each applicable RACT plant.

The study would not include non-manufacturing area cleanup such as cafeterias, restrooms, office buildings, etc., nor would it include non-routine, "one time only type" maintenance cleanup of manufacturing facilities and equipment. To prevent duplication, a source for which there has been a RACT, BACT (best achievable control technology) or LAER (lowest achievable emission rate) determination made within 18 months of the date of this proposed study would be excluded from this new study. Likewise, where there has been, or will be, a cleanup solvent case study involving an identical or similar operation that is transferrable, that case study would not be repeated to fulfill the requirements of this study for that operation. Of course, similarities and differences would be discussed and taken into account in the rationale used to justify the case study transfer.

Where a potential improvement is identified, it would be evaluated, with usage data recorded both before and after. Where potential improvements could not be applied, or trial results are found to be unacceptable, the study would provide appropriate supporting documentation. Any unique plant features or conditions preventing such application of cleanup solvent usage improvements would be identified.

Work procedures and material and equipment changes that have potential for reducing the use of cleaning solvents would be included in this improvement study. All the potential improvements may not be applicable to other motor vehicle manufacturing facilities inasmuch as some will require conditions that are available only at specific plants. For example, efficient collection of purge solvent may only apply where high volume painting is done with automatic spray guns designed with that capability. For various reasons, including retrofit

cost, plant specific configuration, and production materials in use, incorporation of such improvements may not be feasible in every plant industry-wide.

RACT must address "technological and economic feasibility" through evaluation of actual VOC reduction, cost, and feasibility of all factors involved in a decision to change a proven material or procedure. For example, there would not be a net VOC reduction if a cleaning material containing only half as much solvent requires twice as much material to perform the same job. Likewise, there is an identifiable cost burden if a lower VOC cleaner or procedure produces an equivalent cleanup but requires twice as much labor and/or costs more per gallon. An acceptable cleaning liquid for one operation may not be feasible for another if different materials, shapes or surfaces are being cleaned.

MVMA members do not support, nor does this study propose to establish, a cleanup solvent RACT standard based on usage per unit because there are too many other variables. A typical plant painting 30 units per hour does not generally use half as much cleanup solvent as one painting 60 units per hour. There is a given amount of cleaning required once a facility has been used regardless of the number of units produced. Among other things, the amount of cleaning varies depending on the coating material used (chemical nature and ease of clean up), equipment (complexity and shape of equipment), and the parts being sprayed (shapes producing more overspray, and complexity of vehicle model mix).

Maintaining the ability to produce a quality product is also a major MVMA concern. The proposed MVMA study would show those solvent cleanup operations that are important for quality. One level of cleaning may be needed periodically for appearance, but that same level of cleanliness may not be adequate for quality. An area inappropriately cleaned may cause defects on a vehicle. For example, paint particles on overhead equipment that were not removed regularly, have led to multiple "droppings" and defects on the tops of units being painted that had to be repaired. Even though cleanup is an "indirect" use of material and labor, its importance to overall quality and productivity should not be minimized. To do so could lead to arbitrary and erroneous conclusions on what constitutes RACT for cleanup solvents.

Recordkeeping has been demonstrated as a viable and acceptable control tool as part of the Automotive and Light Duty Truck "Protocol" and would be the foundation for performing the proposed study. If accurate records are kept on cleanup solvents entering and leaving a plant, then current or appropriately modified material usage records and material balance calculations, such as those already being used, should present an adequate picture of cleanup solvent usage in each applicable plant.

The recordkeeping required for such a study to identify usage is initially much greater and requires more detail than for ongoing tracking and control purposes. Among the major benefits anticipated for MVMA members in this proposed study would be the identification of realistic key inventory, usage, and control points. Such control points could be used for recording and reporting cleanup solvent usage once rules and permits are established for

plants in each state. Continuing detailed records for individual point sources (i. e., a topcoat booth) on a routine basis would provide little, if any, environmental benefit, be replete with potential inaccuracies, and not be productive. This is in part due to the fact that many cleanup solvents are supplied directly to multiple spraybooths, and/or obtained from a single plant source, rendering accurate tracking of the quantities of solvent used at a specific point source very difficult and burdensome, if not impossible.

In the highly competitive industrial sector where resources must be applied productively, unnecessary recordkeeping must be kept to a minimum. For example, it should not be necessary to show that for a gallon of solvent used in the cleanup of a spray booth that one oz. was used to clean spray gun nozzles, twenty ozs for "wiping down" an automatic reciprocator, and the other 107 ozs. broken down by usage within the spraybooth. It should be sufficient to record that one gallon was used to clean the spraybooth. Likewise, estimating the usage of one, twenty and 107 ozs. should be sufficient so long as there is full accounting for the entire gallon. Further, it should not be necessary over the long run to detail that five gallons of solvent were used to clean the Main Enamel booth and five gallons were used to clean the adjacent Tutone booth so long as the total ten gallons are recorded. A similar rationale can and should be applied to the reporting of data.

The MVMA approach will identify appropriate recordkeeping control points as well as opportunities for potential emission reductions that are unique to each plant and its capabilities.

In summary, the major elements of this proposed study and the content of the sections are as follows:

- Identify Cleanup Solvent Usage
- Identify and Critique Potential Improvements
- Evaluate Most Promising Improvements
- Prepare Report Summarizing Results and Recommendations
- Project Schedule
- Followup Actions

I. Identify Cleanup Solvent Usage

The following areas would be included in the proposed study to identify cleanup solvent usage:

- Body Shop
- Paint Shop
- Trim Shop
- Chassis Area
- Final Prep Area
- General Manufacturing Maintenance Areas

II. Identify and Critique Potential Improvements

Potential improvements found in the study that could reduce cleanup solvent use would be critiqued and screened by plant management for possible adoption. The report in item VI below would provide the rationale should any potential improvement not be trialed for adoption.

III. Evaluate Most Promising Improvements

Those promising improvements that appear beneficial in reducing cleanup solvent usage will be scheduled for appropriate trials, with both before and after usage recorded and evaluated. They will include:

Material Changes

Materials normally evaluated for solvent reduction, cost, usage and labor effect in motor vehicle operations include caustic cleaners, lower VOC cleaners and peelable type booth coatings. The evaluation and decision to incorporate an alternative material such as a cleaner requires site-specific analysis. Many factors determine the effectiveness of a cleaner. These include the type of coating to be removed, time available for cleaning, amount of material to be removed, the type surface being cleaned (walls of glass and stainless, galvanized or mild steel; configuration and detail of equipment, etc.) as well as physical booth constraints such as piping, structural steel present, and space between equipment.

Equipment and Facility Changes

Examples of equipment that could be included in the evaluation study are high pressure water equipment to reduce solvent stripping, floor scrubbers, and removable or replaceable equipment covers. For equipment and facility changes or improvements, not all plants are expected to be capable of incorporating a given change. Booth design, specific operations occurring within a booth, existing equipment within a booth and availability of space to accommodate any retrofit must be considered. In addition, paint quality ~~effects~~ must be carefully considered when any change is contemplated for the paint shop. A faulty trial can produce many vehicles requiring repair before a problem can be reversed.

IV. Prepare Report Summarizing Results and Recommendations

A summary report would be prepared incorporating study data, with a narrative on each area of study. The report will provide a summary of the positive and negative aspects of those material, process and cleanup changes found to be reasonably

effective. Recommendations would be made based on the study results at each applicable RACT plant.

V. Project Schedule

A mutually appropriate schedule will be developed between each affected plant and state or local agency for the proposed study.

VI. Follow-up Actions

Based upon the study results, plans for implementation would be developed in cooperation with EPA, State or local control agency representatives. Consideration for operational flexibility and for equivalency of reduction by alternative means over the longer run, will be needed for any material, process or procedural changes to be implemented. It is anticipated that individual company representatives would work as needed with EPA, State or local agencies to incorporate cleanup solvent plans into permits on a timely basis.

APPENDIX E.
CASE STUDIES

APPENDIX E.

CASE STUDIES

Many companies and industrial facilities now use cleaning solvent accounting systems. They do so routinely as with other raw materials. This section reports on several plants, most of which (1) track usage at a level comparable to the UOS concept, (2) account for purchase costs by department, and (3) account for waste and disposal cost on a plantwide basis.

Many of these plants have analyzed the resulting data to ascertain which areas (unit operations) within the plant would most benefit from changes in cleaning practices, and they have implemented changes. A few of these facilities implemented reduction programs or techniques before initiating their accounting systems, but plant management expects to use information from the systems to quantify the effects of the changes and to identify additional reduction techniques.

The general consensus by the plants is that the overall benefits and cost savings of the changes outweigh the costs to implement and maintain the accounting system. The benefits reported by these plants include reduced cleaning solvent usage, waste, emissions, and costs related to both solvent purchases and waste disposal. In some instances, plants also report reductions in State-imposed emission fees. One facility reduced its usage of one cleaning solvent by 76 percent. Another changed production schedules so that fewer cleanings were needed. They reduced the amount of waste disposal by 35,000 gallons (gal) in 1 year and saved \$100,000. Another plant reports having reduced

its solvent usage by 20 percent in 1 year due to changes in several cleaning procedures.

Many facilities have recordkeeping systems that record material usage for inventory, production, waste disposal, or other purposes that are similar to the needs of a solvent accounting system. While some may not currently track cleaning solvent, the necessary information to do so could be incorporated into the existing tracking programs. For example, one facility in the adhesive manufacturing industry has initiated programs tracking production materials.¹ This plant will eventually incorporate all cleaning solvents with the expectation that data from the tracking system will be used to identify techniques to reduce operating costs associated with cleaning.

Each of the following case studies provides details of different solvent accounting and management systems that have been implemented. Each is presented with an introductory discussion of the approach, followed by specific details on accounting procedures, reduction techniques implemented, and the resulting environmental impacts. Costs related to implementing the solvent accounting systems and reduction techniques are presented in Chapter 5 and Appendix G.

E.1 CASE STUDY A^{2,3}

A facility in the fiberglass boat manufacturing industry, Facility A, implemented a solvent accounting system that tracks the amount of cleaning solvent issued to each department (cost center) and the amount used per boat. The accounting system also tracks the total (plantwide) amount of spent solvent, or waste generated, from cleaning. After analyzing the resulting information, management encouraged substitution of specific solvents and restricted the use of others. Significant reductions in use, emissions, and waste disposal resulted. Although one of the changes made was a greater transition to use of an "exempt" solvent, the case study demonstrates use of a solvent accounting system and subsequent management remedial activities.

The plant uses solvents to clean spray guns, tools, and workers' hands. Acetone, Tipsolve™ (a mixture of methylene chloride, 1,1,1-trichloroethane, acetone, and toluene), lacquer thinner, 1,1,1-trichloroethane, alcohol, and naphtha are traditional solvents used for cleaning. Dibasic acid ester (DBE) was introduced in 1990 and has replaced much of the Tipsolve™ usage.

The solvent accounting system tracks actual allocations of cleaning solvent to each department and the total (plantwide) amount of spent cleaning solvent that is shipped offsite for recycling or waste disposal each month. Historically, this plant tracked acetone and Tipsolve™, the two major solvents. After its introduction, the plant incorporated DBE into the system.

Their normal procedure is to estimate emissions as the difference between usage and total waste. However, because total waste includes both spent solvent and contaminants, it is periodically analyzed to determine the contaminant level, and at the end of the year, a correction is made to more accurately estimate annual emissions.

At this plant, the accounting system distributes the cost of solvents as an overhead expense to user departments based on the historical distribution of usage. The plant is now considering using the allocation records to charge user departments on an actual-use basis. At this plant, waste disposal costs are not back-charged by department, but rather are charged to the maintenance department, which is responsible for collecting and disposing of hazardous waste.

The plant made a number of changes in its cleaning program. The solvent accounting system has documented the impact of these changes on usage rate, emissions, and collection rates for recycling and waste disposal. Reductions occurred both because of these changes and because of reduced production rates. At the end of the year, the plant normalizes only Tipsolve™ emissions relative to production levels (as described below) but believes that overall, normalized solvent usage, emissions, waste generation, and cost have all declined.

Solvent accounting helped management identify at least one example of how acetone was clearly being wasted. As production declined, acetone use remained nearly constant because the daily allocation to each employee did not change. This procedure increased waste because unused solvent had to be disposed; it could not be returned to storage. To correct the problem, daily employee allocations of acetone were reduced from 5 to 2.5 gal. Five-gal safety cans are gradually being replaced with 2.5-gal cans. Tighter lids are being required to prevent emissions. The reduction in unit issue of acetone has reduced not only usage but also the amount of waste generated. Cost savings are dual, both the purchase cost of solvent and the cost of waste disposal.

To facilitate the switch from Tipsolve™ to DBE, management placed limits on individual usage of Tipsolve and allowed unlimited use of DBE. In April 1990, prior to the changeover, management issued an allowance of 5 gal/d of Tipsolve™ per production line. In September 1990, when DBE was introduced, management further restricted Tipsolve™ use to 2.5 gal per line but allowed unlimited access to DBE. Management verbally encouraged employees to use even less Tipsolve™.

Tipsolve™ usage from September 1990 to February 1991 showed a steady decrease from 484 gal per month (gal/mo) to 114 gal/mo, a 76 percent reduction in usage. (This trend is shown in Figure E-1).³ Total usage has since continued to decline, as has the amount of waste Tipsolve™ generated. The plant has calculated a "normalized emission rate" based on production; emissions for 1990 decreased by 34 percent over 1988 and 1989.² Emissions for 1991 decreased 83 percent from 1988, and a reduction of 95 percent over 1988 is expected by the end of 1992 or early 1993.

Usage of DBE, also shown in Figure E-1, increased from 0 to 90 gal/mo from September 1990 to February 1991. Since February 1991, the DBE usage has declined as employees have improved application procedures. The DBE is less volatile, employees do not need to soak rags as with Tipsolve™, and DBE can

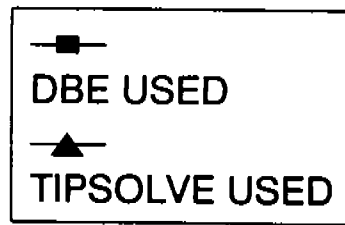
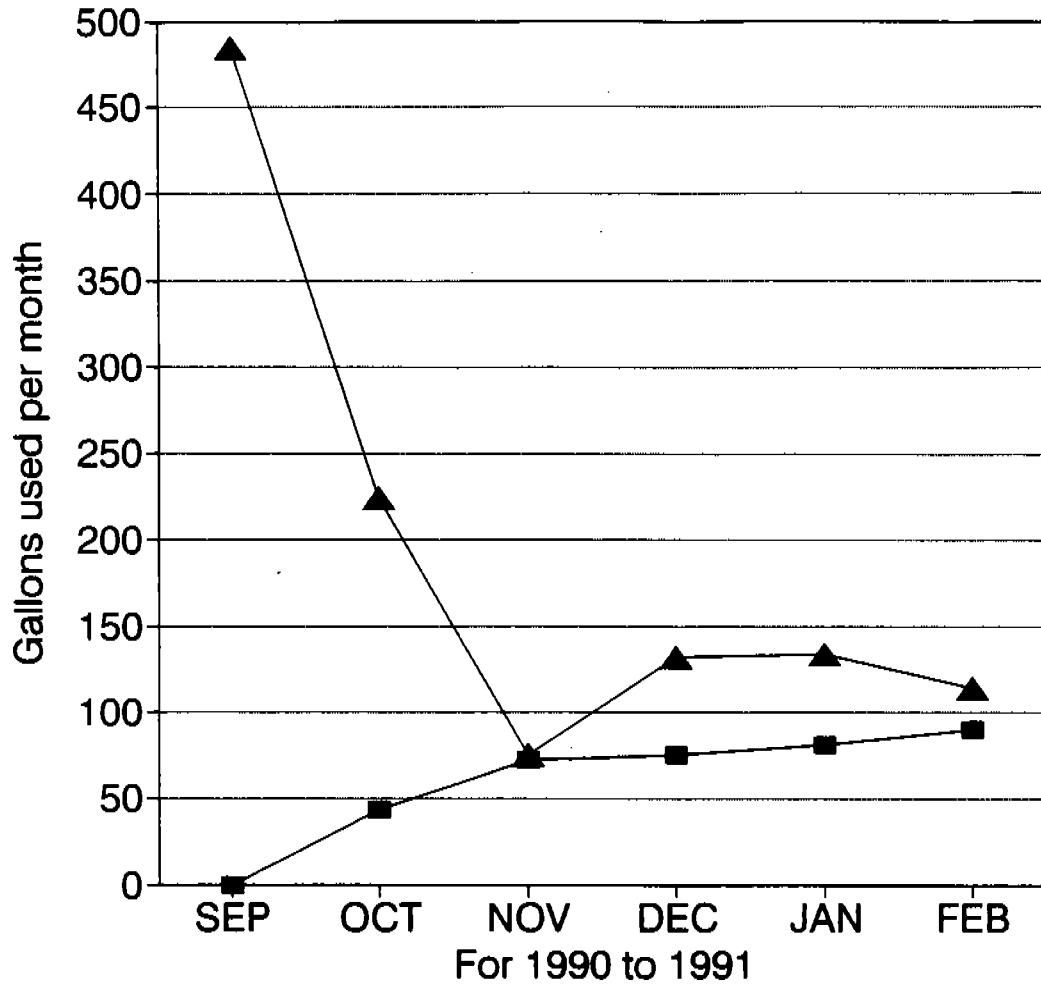

Note: Data are not normalized for all accompanying decline in production.

Figure E-1. Substitution of DBE for Tipsolve™.³

be used longer than Tipsolve™ for dipping. Usage stabilized in late 1992.

Training was provided for employees before and after the change to DBE. The initial 90-minute training session was attended by 75 to 100 employees. It presented a description of DBE, how to handle it, an explanation of why the switch was being made, and a lengthy question-and-answer period. In a followup session, employees provided feedback on the performance of and problems with DBE.

E.2 CASE STUDY B⁴

A textile company reduced its solvent usage at five separate but geographically close textile mills by changing accounting procedures. Under its previous accounting system, cleaning solvent (and other supplies) for all five plants was stored in a common location. The solvent was not inventoried (i.e., usage at each plant was not recorded), and the purchase cost for solvent was prorated equally among all five plants; each plant was charged for 20 percent of the total. In effect, then, any single mill paid for only 20 percent of its incremental solvent usage. With the new computerized system, actual usage at each plant is recorded, and each plant is charged for its usage. Solvent purchases declined after introduction of the new system.

E.3 CASE STUDY C^{5,6}

Facility C, in the paper and vinyl coating industry, implemented a solvent accounting system in which cleaning solvent usage is tracked at each coating machine and parts washer (i.e., two types of unit operations). Plant management believes that this accounting system will provide valuable information in its effort to reduce the usage, waste disposal, and associated costs. Although the plant implemented several new cleaning procedures in 1991, before implementing the accounting system in April 1992, management expects the accounting system to help identify other possible efficiencies in cleaning procedures.

Numerous VOC-based solvents are used at the plant including methyl ethyl ketone (MEK), ethyl acetate, and toluene. Coating machines are flushed with solvent, and various parts are removed

from the coating machines and dipped in wash tanks. Historically, these cleaning activities were performed after each production run. (Their coating machines are vented to a control device during cleaning; wash tanks are not.)

In late 1991, this plant implemented both a process change and several changes in cleaning procedures that have reduced solvent usage, emissions, and waste generation. The process change eliminates some cleaning steps by scheduling compatible coating formulations successively on the coating machine. One work practice change is to reuse cleaning solvent until it becomes too contaminated. The plant now also restricts the cross-sectional area of wash tanks and the amount of solvent the wash tank may contain. New, smaller, wash tank equipment was purchased that reduces the solvent-to-air interface. Management standardized cleaning procedures that operators are to follow. Floor cleaning with MEK, an extremely volatile solvent, was eliminated. Floors are now cleaned with an aqueous solution (The facility reported that this change had a relatively small impact compared to the other changes they made.).

Although the plant recognizes reductions achieved by the changes, all are not quantifiable because the changes predated implementation of the accounting system. Significantly, however, records of cleaning waste disposal indicate a reduction of 35,000 gal from 1991 to 1992.

The plant implemented the accounting system in April 1992 and plans to consider additional changes after collecting data for a year. Tracking will continue to provide data that will be used to quantify the benefits of subsequent changes relative to the base year.

Operators now manually record the amount of solvent used to clean each coating machine and the amount added to the wash tanks (parts cleaners) to clean removable parts. The information is subsequently entered into a computer data base. Operators spend approximately 5 minutes per day (min/d) recording information for each of 19 machines, and one spends 0.5 hour per day (hr/d) entering the information into the data base. Analyzing and

compiling the information to identify changes or to track trends requires an average of 0.5 hr/d. The same employee enters and analyzes the cleaning data. The plant used an existing computer, and 8 to 10 hr were devoted to developing the data base spreadsheet.

The costs of solvents used for production and cleaning, as well as disposal costs, are charged as overhead expenses. Waste from cleaning is tracked by the safety and environmental department. All waste solvent from the plant is from cleaning.

The labor required for each cleaning has not changed at this plant, but the number of cleanings per year has declined due to scheduling changes. The total manhours per year on cleaning has declined.

Because tracking of cleaning solvents at the plant required changes on recordkeeping forms, initial training sessions were held for eight operators and supervisors to explain the new procedures; a total of about 14 manhours were devoted to these sessions. Additional training for operators is an ongoing process that is conducted by the employee who evaluates the data base information. This employee sends memoranda to management and operators clarifying issues that appear to be problems or to implement new procedures. He also chairs a bimonthly quality improvement meeting. Total manhours in ongoing training are about 5 per month.

E.4 CASE STUDY D^{7,8}

Facility D, in the coated films and paper industry, implemented a solvent accounting system in which cleaning solvent usage is tracked by individual coating machine, mix tank, or wash tank (parts cleaner). Based on information it provided, the plant has also implemented changes in cleaning procedures. Numerous small programs were initiated to reduce solvent usage and waste generation. Management expects to identify more cleaning solvent usage and waste reduction techniques. A new system with special material tracking abilities for product formulations will be started in 1993. It will allow real-time input of solvent usage into a data base by operators.

Cleaning activities at the plant include flushing coating machines and pipes, flushing and wiping tanks, and dipping parts in wash tanks (parts cleaners). Acetone is the most common solvent. No limits are placed on the amount that employees can use; the amount used is based upon the operator's judgement of his or her needs. Changes in procedures may be implemented without supervisory review and approval. Usage of solvents is manually recorded on mix tickets on the basis of cleaning one machine, one tank, the parts washer, etc. These tickets are first routed to the inventory department, where a clerk enters information into a computer for inventory control. The information is later entered into a second data base by a manager in the environmental department. Most equipment is vented to a control device during cleaning, and emissions to the atmosphere due to cleaning are reportedly very small.

Each department within the plant is charged for the actual materials it uses and is allocated appropriate waste disposal costs as explained below. Waste solvent information is kept by the solvent recovery department. The total cost of waste disposal is reported to the environmental department, which in turn, allocates costs to individual departments based on the usage information reported on the mix tickets.

Information from this solvent accounting system has been monitored over the years to help management identify areas to reduce usage. Several changes in cleaning procedures have been made, such as use of the "third-cycle rinse solvent" for the first rinse cycle of next cleaning. Some of the dirtiest solvent from the first rinse cycle is then used in production formulations. Additional reductions in usage have been achieved after several small programs to investigate possibilities. In one, operators tried using less solvent to clean tanks, in some instances only half of normal use. The results were acceptable, and the smaller amount is now used for tank cleaning. In another program, operators discovered that merely soaking a tank (allowing it to sit full of solvent) for a period of time cleaned as well as did rinsing it several times. Less solvent is needed

to clean a tank. Downtime increased, of course, so a compromise of soak time and the number of rinses was necessary.

No one change has resulted in major reductions, but collectively, numerous changes have led to sizable reductions in both usage and waste generation. From 1990 to 1991, cleaning solvent usage declined 20 percent. Waste generation was reduced, but the plant did not track or keep records on the amount of the reduction.

The plant reports that costs exceeded savings in the first year following implementation of the accounting system. Within a year or two, as the reduction techniques were phased in, savings began to exceed costs. The plant did not quantify the costs but indicated they are low. For example, recordkeeping costs are incidental because operators spend little time recording chemical usage.

The accounting program will be modernized in 1993 using a new plantwide computer system. Operators will directly enter information into the data base rather than on mix tickets. The new equipment, which will cost \$2 to \$3 million, was justified for process purposes. Incorporation of a chemical tracking program is a minor incremental use and tracking of cleaning solvent even smaller. The company was unable to estimate the incremental cost of the cleaning solvent accounting system to the base computer system's cost.

E.5 CASE STUDY E^{9,10}

Facility E, in the can coating industry, implemented a solvent accounting system that tracks process materials, including cleaning solvents. This accounting system resulted from the South Coast Air Quality Management District's (SCAQMD's) Rule 109, which requires coating facilities to record solvent used to clean equipment and to calculate emissions from cleaning practices. In 1991, the plant began to enter solvent usage into a computer data base, and limits were placed on the amount of solvent to be used for cleaning the equipment. The plant also implemented a solvent substitution program. Records reveal that these practices have resulted in reductions in usage, waste

generated, and emissions. Further, after analysis of accounting data, the plant identified areas of apparent "overuse" but has not yet taken remedial action.

Solvent accounting procedures at this plant have evolved over the years. Prior to Rule 109, daily solvent usage and waste generation records were kept on a plantwide basis. After passage of Rule 109¹¹ in 1989, operators manually recorded the actual solvent usage for each coating machine and wash tank (individual unit operations). In 1991, the plant employed a consultant to develop/implement a software system for tracking solvent usage on their existing computers. Daily, a manager enters data from the usage records into the computer data base. The system is programmed to calculate VOC usage based on the total solvent usage data and the compositional analysis of the solvents. It is also programmed to compare the actual usage rates with accepted rates and automatically generates a notification if overuse occurs. The amount of waste solvent collected from cleaning is recorded on an overall plant basis. Wastes are not segregated; coating and cleaning solvents are collected together.

Emissions are calculated by two procedures. First, Rule 109 requires daily records of emissions, assuming they equal usage. The plant realizes this procedure overestimates emissions because the plant collects some spent solvent for disposal. (At the end of the year, therefore, the plant also estimates actual emissions based on the difference between usage and the VOC content of the waste. Analyses show the waste is about 71 percent VOC.)

Each department is allocated a quantity of solvent for its cleaning needs. Supervisors distribute cleaning solvents, thereby limiting operator access. The plant also provides specific guidelines for its operators on the amount of solvent used for cleaning each coating machine. (No such limitations on solvent use are placed on wash tanks.) These guidelines were developed from information collected by the solvent accounting system. The department and equipment guidelines and supervisory distribution of solvent have been in effect since 1991.

Cleaning solvents are overhead costs charged to a department on the basis of actual usage. Waste disposal costs are borne by the plant.

Plant management investigated solvent substitution and in 1990 began using glycol ether, a low-vapor-pressure solvent, in place of methyl isobutyl ketone and MEK. The plant changed to aqueous coatings and adhesives for several of its operations in the spring of 1992 and, with this change, also switched to aqueous cleaning solutions to reduce both employee exposure and emissions. Most equipment and the floors at the plant are now also cleaned with aqueous solutions. Some cleaning procedures, such as flushing coating equipment, wiping rollers, and dipping parts into one wash tank, however, still involve the use of VOC solvents.

The plant reports that implementing and maintaining the accounting system has not been burdensome. Operators spend a total of 3 hours per week (hr/wk) recording usage information. One manager spends approximately 2 hr/wk entering information into the data base. The plant's consultant annually evaluates and analyzes information in the data base.

The plant has reduced cleaning solvent usage and emissions. Management attributes the reduction to both the accounting practice and the allocation limits but affirms that the reduction is primarily due to the accounting, which has made employees conscious of their individual solvent usage. Emissions declined 65 percent (from 10 to 3.5 tons) from 1988 to 1991. The plant, as required by the rule, assumes usage and emissions reductions are equal. Thus, waste disposal rates have remained constant.

The plant plans to use the information from the accounting system to identify other areas of waste and overuse. The plant reports that such identification efforts are much easier when information is recorded at the equipment level rather than the plant level.

The plant has historically trained employees on cleaning practices. When the data base was implemented and the limitations on solvent use began, management explained that

solvent was being limited to reduce usage and emissions. Further, they explained that the amount of solvent used would be compared to the allocated amount of solvent needed for cleaning equipment. Training for the employee that enters information into the data base required 6 hr and was provided by the plant consultant who also maintains the computer system.

E.6 CASE STUDY F¹²

A plant in the can coating industry, Facility F, implemented a solvent accounting system that tracks solvent used for cleaning both equipment and parts. The facility is subject to several SCAQMD rules, including Rule 109 (explained for Facility E). Prior to Rule 109, the plant tracked cleaning solvent for each unit operation for the inventory and to monitor the amount of solvent used for cleaning. Accounting procedures did not change after Rule 109, but the plant did implement a few successful reduction techniques.

Cleaning at the plant includes wiping rollers used in the coating operations and dipping coater parts into wash tanks (parts cleaners). Butyl Solvent™, composed of xylene and ethylene glycol, is used for cleaning. Cleaning is required between customer orders. General guidelines on the amount of cleaning solvent needed for particular tasks were obtained from an audit conducted when the plant first opened in 1985.

Operators manually record cleaning solvent usage for each coating machine, press, and wash tank. They spend approximately 30 to 40 min/d manually entering usage information on log sheets and double-checking their numbers. A manager spends approximately 10 to 15 min/d reviewing records from operators for inconsistencies, and if more solvent is used on a particular piece of equipment than the amount normally required, the operator is questioned. The information is later added to a written inventory by a manager, and the amount used is subtracted from inventory. Handling accounting activities related to material usage consumes a major part of one manager's time.

The cost for cleaning solvent is charged to each department based on actual usage. Accounting by department has been a

driving force in reducing usage because the accounting provides the department manager, who is striving to reduce costs, with actual usage and cost information. Waste from cleaning is not tracked by equipment but rather on a plantwide total basis, so these costs are not charged to individual departments.

Evaluation of information from the accounting system revealed several work practices that resulted in overuse of solvent. The plant then implemented a few changes. For example, unnecessary cleanings, such as cleaning ink pails when they are ready to be disposed of offsite, were eliminated. The use of spray bottles was also discontinued, which has helped to decrease the evaporation rate of cleaning solvent.

While the plant did not quantify specific results of their program, management reports these changes led to reductions in both cleaning solvent usage and waste generation. Careful attention from management on recording practices has made operators more aware of their solvent usage, and this awareness has also led to reductions.

It is also likely that the changes in work practices reduced emissions. In fact, the plant reports reductions because it assumes emissions equal usage, as required by Rule 109. However, the plant also collects some spent solvent for waste disposal, which means it overestimates emissions using this assumption. It also means the actual emission reductions cannot be calculated without before and after usage and waste data, which the plant did not share with EPA.

Operators are trained regarding cleaning practices. Monthly departmental meetings are held that include discussion of topics such as production efficiency, recordkeeping inconsistencies, safety, and refresher training for a variety of practices. These meetings last approximately 1 to 1.5 hr and approximately 35 to 40 people attend. A manager holds an additional monthly meeting to discuss any planned changes in practices or problems that have occurred.

E.7 CASE STUDY G^{13,14}

Facility G, in the coil coating industry, has implemented a solvent accounting system that tracks solvent usage for equipment cleaning (i.e., a unit operation). This facility is also subject to California's SCAQMD Rule 109, which requires recording of solvent used for and emitted from cleaning. The plant has also implemented a solvent reduction program that changed some cleaning practices. The accounting system and the reduction program are reported to have reduced cleaning solvent usage, waste, and emissions.

Coating equipment is cleaned at the plant with Cleanup Solvent™, which contains MEK, toluene, isopropanol, and petroleum distillate. Cleaning is necessary between customer orders. Coating equipment (the paint pan, roller machinery, and roller surfaces) is cleaned as one unit operation.

The plant has manually tracked solvent usage on a unit operation basis since the plant first opened to confirm that expected inventory was used on schedule. After Rule 109, this information has been entered into a computer data base by a clerk in the production control department.

The quantity of cleaning waste generated is recorded plantwide. It is easy to track because it is generated in only one area of the plant. Also, except for a small amount of coating solvent that remains in the paint pan, waste cleaning solvent is collected separately from other waste.

Emissions are estimated by subtracting the amount of waste collected from cleaning (corrected for the contaminants) from the solvent used. These emissions are captured and vented to a control device. The capture and destruction efficiencies of the control system are used to calculate the actual emissions to the atmosphere.

The plant implemented a few cleaning procedural changes to reduce solvent usage and waste. The plant provides guidelines for operators on the specific amount of solvent needed for cleaning equipment. It was determined by trial and error that the least possible amount of solvent that cleans effectively is

2 gal per coating machine. This guideline has been in effect since shortly after the plant opened. The plant has also prescribed changes in cleaning practices such as scraping coater pans and rollers to remove excess coating material prior to cleaning.

These changes reduced solvent usage, waste, and emissions related to cleaning between 1986 and 1987. Usage was reduced 45 percent, from 40.8 to 22.4 tons. Waste disposal decreased 25 percent from 41.0 to 30.6 tons. Emissions were calculated as the difference between usage and the VOC content of the waste, which, according to the plant, was about 70 percent in both years. Thus, emissions decreased 92 percent from 12.1 to 0.98 tons. (These emissions are captured and sent to a control device, so emissions to the atmosphere reportedly declined from 0.5 to 0.04 ton.) These reductions are shown in Table E-1.

TABLE E-1. REDUCTIONS AT FACILITY G

	1986	1987	Net reduction	Percent reduction
Usage	40.8 tons	22.4 tons	18.4 tons	45
Waste ^a	41.0 tons	30.6 tons	10.4 tons	25
Emissions	12.1 tons	0.98 ton	11.1 tons	92

^aAt 70 percent VOC.

Recordkeeping associated with the accounting system has made operators more aware of their cleaning practices and made them more frugal and efficient with usage. Upkeep of the accounting system requires some labor input from operators and managerial staff. A total for all operators of 8 hr/wk is spent recording cleaning solvent usage, and the clerk in the production control department spends 14 hr/wk inputting these data into the data base. A manager then spends 1 hr/wk evaluating the information.

The plant provides training for all operators before they perform cleaning. Before implementation of the accounting system, training was provided for eight operators and the

employees that enter and evaluate data. New personnel also receive this training as part of their orientation. An annual meeting, which lasts approximately 15 min and is attended by three people, is held to provide refresher training to operators.

When the plant initiated its program several years ago, a meeting was held to explain the planned changes and their purposes to operators. A roundtable meeting including both management and operators was also held when the plant began its reduction program. Many viable ideas were presented by operator staff, and some of the techniques implemented originated with operators.

E.8 CASE STUDY H¹⁵

An automotive company implemented a program to reduce the variety and amounts of chemicals, including cleaning solvents, used by its plants and to reduce the cost to dispose of hazardous waste. The reduction program included a team that first examined the usage of "indirect," or nonproduct, chemicals. This team discovered that corporatewide, the company used thousands of different cutting oils to perform equivalent operations and that even within an individual plant there often were many similar commercial products used by different people to accomplish the same cleaning. This assortment of supplies, including cleaning materials, resulted from personal preferences of employees and also from a large number of visits by salesmen to the plants. Duplication produced additional inventory, storage, and disposal costs for the plants. The team's conclusion was that normal market forces tended to swell the number and types of products that must be kept in inventory.

The corporation began an experimental program by hiring a contract firm to be responsible for supplying chemicals, defining and performing cleaning procedures (as long as production is unaffected), and handling waste disposal for a single plant. This firm acted as liaison between the plant and suppliers. Its responsibility was to reduce indirect or nonproduction chemical usage and costs by various methods. It, in effect, became the holding company for those chemicals and the resulting waste using

just-in-time delivery principles and minimizing inventoried products. In previous practices, indirect chemical and disposal costs were charged to plant overhead. With the new program, the contract firm bids a fixed price for supplying segments of the plant and is responsible for meeting these contractual costs. This provides the contractor with the profit incentive to reduce the costs of supplying the indirect chemicals. In effect, the experiment made these chemicals, which are incidental to the assembly of automobiles, the major profit mechanism for the contractor. The company has been adding plants to the program since 1987.

The contractor has recommended several changes to reduce the use of solvents (and the cost of cleaning). One engine plant was able to reduce cleaning frequency by making a process change in its honing operation. Engines were previously honed with a solvent-oil solution, followed by a washing operation. The solvent-oil honing solution contaminated the washer, necessitating emptying and cleaning the washer every other day. After switching to an aqueous honing solution, the washer now requires cleaning only once every 4 weeks.

Another change reduced the wasteful use of purge solvent in paint shops. Previously, solvent was readily available to the painters via manual valves on the solvent distribution lines within each spray booth. These lines have been blocked at some plants.

The failure rate of engines at one engine manufacturing plant was reduced by improving cleaning practices. A management team established specifications for cleanliness of engine parts and then developed methods to meet the specifications. The failure rate of engines has declined from 30 per month to only 2 (when the car is ready for shipping and the engine will not start, a new engine is installed, a very costly step).

One of their plants targeted waste disposal of paint residue from paint spray booths. This plant made changes in the technology used to detoxify paint sludge from its spray booths and was able to reduce disposal costs.

The company's plants have reduced the usage, waste, and cost of indirect chemicals by an average of 30 percent overall in the plants that have implemented accounting and managerial techniques and by 50 percent in some cases. One plant saved more than \$2 million on paint sludge waste disposal costs. Management attributes its success to the accounting system, which permitted management to identify where major quantities are used. The next step was an aggressive effort by management to change practices.

E.9 CASE STUDY I¹⁶

Several plants in the aerospace industry have assessed their solvent usage and subsequently changed cleaning practices to reduce usage; others are starting or planning assessment programs. One plant instituted a sophisticated accounting system where employees are required to check out solvent by project and employee number from a "chemical crib" and return any leftover chemical for storage or waste disposal. At the same time, the plant established limits on the amount of solvent to be allocated for specific cleaning tasks. These procedures reportedly achieved significant usage reductions.

In many cases the accounting results revealed that the initial allocation limits were generous and could be reduced for even greater savings. In response to their own assessment programs, plants at other aerospace companies have also implemented the procedure of dispensing solvents from a centralized chemical crib and tracking their use. Some have also implemented various work practice procedures (such as replacing 5-gal pour spout and immersion containers with 1-quart dispensing bottles), solvent substitutions, and training programs to teach good work practices and to inform employees of the environmental benefits of reduced usage.

E.10 REFERENCES FOR APPENDIX E

1. Letter from Gelli, J., Courtald's Aerospace, to Schmidtke, K., MRI. August 13, 1992. Summary of material tracking information.

2. Telecon. Randall, D., MRI, with Joyner, L., Hatteras Yachts. July 24, 1992. Solvent accounting and management procedures.
3. Memorandum from Trenholm, A., and K. Schmidtke, MRI, to Serageldin, M., EPA/CPB. June 25, 1992. Site visit report of Hatteras Yachts in High Point, North Carolina.
4. Telecon. Berry, J., EPA/CPB, with Linker, J., Wiscassette Mills. August 12, 1992. Solvent accounting techniques.
5. Telecon. Schmidtke, K., MRI, with Irish, D., Flexcon Corporation. August 11 and 17, 1992. Solvent accounting and management procedures.
6. Telecon. Schmidtke, K., MRI, with Irish, D., Flexcon Corporation. March 3, 1993. Costs and impacts related to solvent management techniques.
7. Telecon. Schmidtke, K., MRI, with Brown, G., Graphics Technology International. August 11 and 14, 1992. Solvent accounting and management procedures.
8. Telecon. Schmidtke, K., MRI, with Brown, G., Graphics Technology International. December 8, 1992. Solvent accounting and management procedures.
9. Telecon. Schmidtke, K., MRI, with Facility E. August 27 and November 24, 1992. Solvent accounting and management procedures.
10. Telecon. Schmidtke, K., MRI, with Facility E's Consultant. November 25, 1992. Costs and impacts related to solvent management techniques.
11. South Coast Air Quality Management District. Regulation I - General Provisions, Rule 109 - Recordkeeping for Volatile Organic Compound Emissions. Adopted May 5, 1989.
12. Telecon. Schmidtke, K., MRI, with Facility F. September 1, 1992. Solvent accounting and management procedures.
13. Telecon. Schmidtke, K., MRI, with Koenig, J., SupraCote, Inc. September 2 and December 3, 1992. Solvent accounting and management procedures.
14. Letter from Koenig, J., SupraCote, Inc., to Schmidtke, K., MRI. January 11, 1993. Costs and impacts of solvent management techniques.
15. Telecon. Berry, J., EPA/CPB, with Mishra, R., General Motors Corporation. 1992. Solvent accounting and management procedures.

16. Personal communication between Serageldin, M., EPA/CPB, and Booth, V., EPA/CPB. 1992. Solvent accounting and utilization procedures in the aerospace industry.

APPENDIX F.

DRAFT TEST METHOD FOR DETERMINING THE PERFORMANCE
OF ALTERNATIVE CLEANING FLUIDS

APPENDIX F.

DRAFT TEST METHOD FOR DETERMINING THE PERFORMANCE OF ALTERNATIVE CLEANING FLUIDS

This appendix presents a draft test method for evaluating the performance of alternative cleaning fluids. Any fluids may be tested, but the primary intent is that it will be used to evaluate the performance of alternatives relative to a VOC solvent. It is a screening technique designed to determine whether the alternative(s) cleans at least as well as a currently used VOC solvent in a simple, standardized wiping application. The results of this procedure may not mimic those that would be achieved for a different scenario in an industrial setting (e.g., spraying or wiping a complex shape). However, any cleaning fluids that are unsatisfactory in this test can be eliminated from consideration for more complicated site-specific tests. This test method has not yet been validated.

F.1 STANDARD TEST METHOD FOR DETERMINING THE PERFORMANCE OF ALTERNATIVE CLEANING FLUIDS

F.1.1 Introduction

Industrial plants use VOC solvents to clean numerous contaminants from a variety of materials in different configurations. Alternative solvents and cleaning fluids exist that would produce lower VOC emissions from many of these cleaning applications. This method involves comparative testing of an existing VOC solvent with alternatives using one standardized cleaning procedure. It is a screening technique that identifies which alternative fluids clean as well as or better than an existing VOC solvent. Because it may not reproduce the plants' actual cleaning procedure, nor determine

the effect of the alternative on the performance of coatings applied to the cleaned surface, it is likely that additional site- or industry-specific tests will be needed before the alternatives that pass this screening test are adopted.

This method is based on ASTM Method D 4828-91 for determining the practical washability of organic coatings. Changes were made to the method to allow its use in new applications. The changes include a wider variety of acceptable test panel materials, contaminants, and cleaning fluids. Procedures for evaluating the results are also different. The cleaning apparatus and procedure were not modified.

F.2 APPLICABILITY AND PRINCIPLE

F.2.1 Applicability

This method applies to the determination of the relative ease of removal of contaminants from a variety of materials/ surfaces by manual or mechanical cleaning with a sponge and various solvents or other cleaning solutions.

F.2.2 Principles

A contaminant is applied to a test panel to represent a typical industrial cleaning situation. One portion of the soiled panel is scrubbed with a sponge and the existing solvent, and another portion is scrubbed with a sponge and an alternative solvent or cleaning solution that produces lower VOC emissions. The performance of the alternative is then rated as (1) worse than the existing solvent, or (2) as good as or better than the existing solvent.

F.3 APPARATUS

1. Sponge and Holder¹
2. Contaminant Applicator
3. Weight, 100 g

¹A sponge, 3 by 3¼ by 1¼ in. (75 by 95 by 45 mm), Part No. AG-8116, and a metal holder, Part No. AG-8115, available from BYK-Gardner, Inc., 2435 Linden Lane, Silver Spring, MD 20910 or a sponge, Part No. WA 2222, and metal holder, Part No. WA 2220, available from Paul N. Gardner Co., 316 N.E. First Street, Pompano Beach, Florida 33060-6699 have been found acceptable for this purpose. An equivalent may be used.

4. Balance, Weighing Accurately to 0.1 g
5. Doctor or Bird Film Applicator, having a 7-mil (0.18-mm) clearance by 6-in. (150-mm) film width
6. Panels of various materials, 17½ by 6½ by ¼ in. (455 by 165 by 6.3 mm)
7. Washability Machine²
8. Masking Tape
9. Straightedge, approximately 17 in. (430 mm) in length
10. Cotton Tipped Swabs
11. Medicine Droppers
12. Suction Plate, for drawdowns

F.4 REAGENTS AND MATERIALS

F.4.1 Contaminants

Examples that may be used with this test method include, but are not limited to pencil, crayon, ball-point pen, waterborne felt-tip markers, grease, and mineral oil.

F.4.2 Solvents and Cleaning Solutions

Examples that may be used with this test method include any VOC solvent or alternative cleaning fluid.

F.4.3 Test Panels

Different types of panels may be selected to match the cleaning application. Examples include, but are not limited to, glass, stainless steel, aluminum, and plastic. The surface may be painted or unpainted.

F.5 PREPARATION OF APPARATUS

F.5.1 Washability Machine

Level the apparatus before use and operate at 37 ± 1 cpm. (A cycle consists of a complete forward and reverse stroke.)

²Washability machine, Model AG-8100, available from BYK-Gardner, Inc. or Model WA 2037D, available from the Paul N. Gardner Co., have been found suitable for this purpose. Other straight-line wash testers may be adapted to meet the requirements of this test method.

F.5.2 Sponge and Holder

Add sufficient weight to the holder in the form of metal sheets or other flat weights to give a combined weight of 1000 g, including the dry sponge.

F.5.3 Test Panel

Prepare paint coated panels by the following procedure. Stir the material thoroughly and strain, if necessary, to remove all skins and particles. Draw down the coating on the panel. Apply the coating in 3 to 4 s from end to end to prevent pin holes or holidays in the film. Air dry all panels in a horizontal position for 7 days in a room maintained at $73 \pm 3.5^{\circ}\text{F}$ ($23 \pm 2^{\circ}\text{C}$) and $50 \pm 5\%$ relative humidity as described in Specification D3924, or under conditions specifically applicable to the material under test. Prepare enough panels with each paint for all the projected tests.

Before use, clean the top of the test panel (painted or unpainted) to be sure it is free of specks.

F.6 PROCEDURE

F.6.1 Application of Contaminants

1. Apply the selected contaminants to the test panel (or coating on the panel) in one straight line parallel to the length of the panel for the manual method of cleaning, or in a pair of lines perpendicular to the length of the panel for the mechanical method of cleaning.

2. Apply solid contaminants using the apparatus shown in Figure F-1. Insert pencil, crayon, pen or similar items into the appropriately sized hole and secure its position so it extends $1\frac{1}{2}$ in. (40 mm) beyond the panel (see Figure 1(a)). Secure the medium in position with a piece of masking tape (see Figure 1(b)). Put the wooden applicator panel at one end of the test panel and place the 100-g weight on its top face at the end nearest to the marking device, as shown in Figure 1(b), securing it with a piece of tape. Allow the nonweighted end of the wooden applicator panel to rest on the surface of the test panel, then hold it by the outer edges and pull it along the entire length of the panel (see Figure 1(c)).

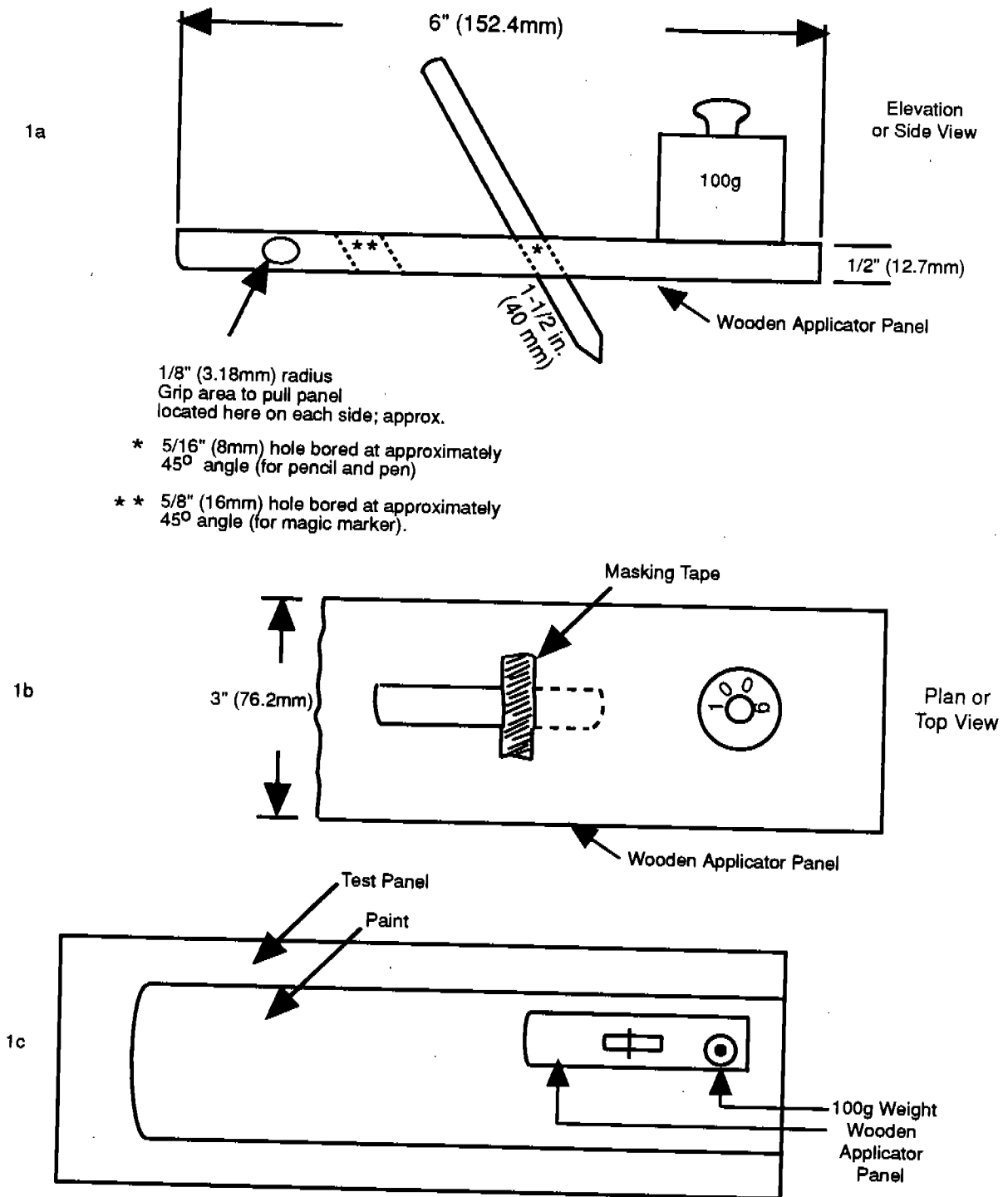

Figure F-1. Contaminant application.

3. Apply liquid contaminants using hand-held cotton-tipped swabs. Immerse one end of a cotton-tipped swab in an appropriate solvent or cleaning solution and allow to remain totally immersed until the cotton tip is saturated (approximately 10 to 15 sec). Remove the tip from the liquid and apply the first of two parallel lines to the test panel using the straightedge to assist in drawing the lines. Adjustment of pressure on the cotton tip may be required to provide a line of uniform intensity. Reimmerse the cotton tip in the liquid and then draw the second line. Repeat with a clean or unused cotton tip for each liquid being used. Permit the contaminants to dry at least 1 hr under the same temperature and humidity conditions as in 5.4.

Note 1—Only one contaminant may be tested at one time.

Typically, as noted above, this will mean the application of one line for manual cleaning or two parallel lines of contaminant for mechanical cleaning. As shown in Figure F-2, one section of the panel will be used to test the VOC solvent and another section will be used to test an alternative cleaning fluid. However, the panel may be long enough to allow evaluation of more than one alternative cleaning fluid in a single test.

F.6.2 Cleaning

1. Soak the sponge in the solvent or solution at ambient temperature until saturated. Remove the sponge and squeeze with one hand until no more liquid drips from the sponge. Replace the sponge in the holder and pour 15 ± 1 mL of solvent or cleaning solution on the exposed face of the sponge.

2. Apply 5 mL of solvent or cleaning solution in parallel bands to each contaminant line.

F.6.3 Manual Method

1. Place the sponge and holder at one end of the panel so that its long axis is perpendicular to the length of the panel (see Figure F-2). Rub the sponge across the panel over the contaminant lines, exerting minimum downward pressure. Continue rubbing until all the contaminants are removed or to a maximum of 100 cycles. If all the contaminants are removed prior to

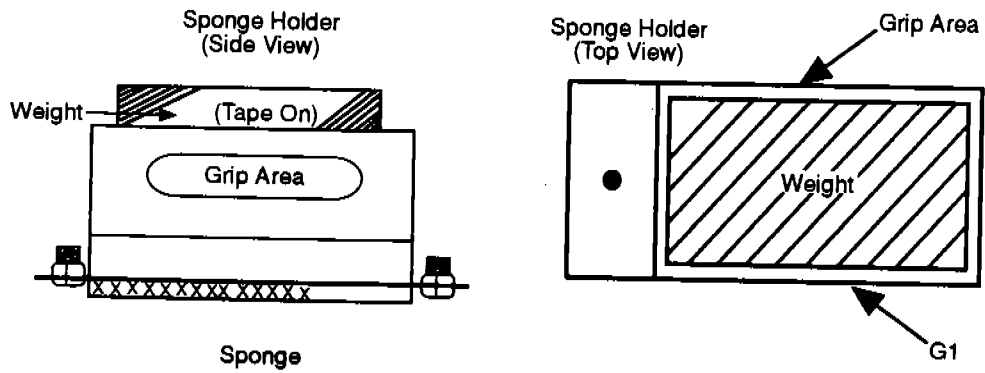
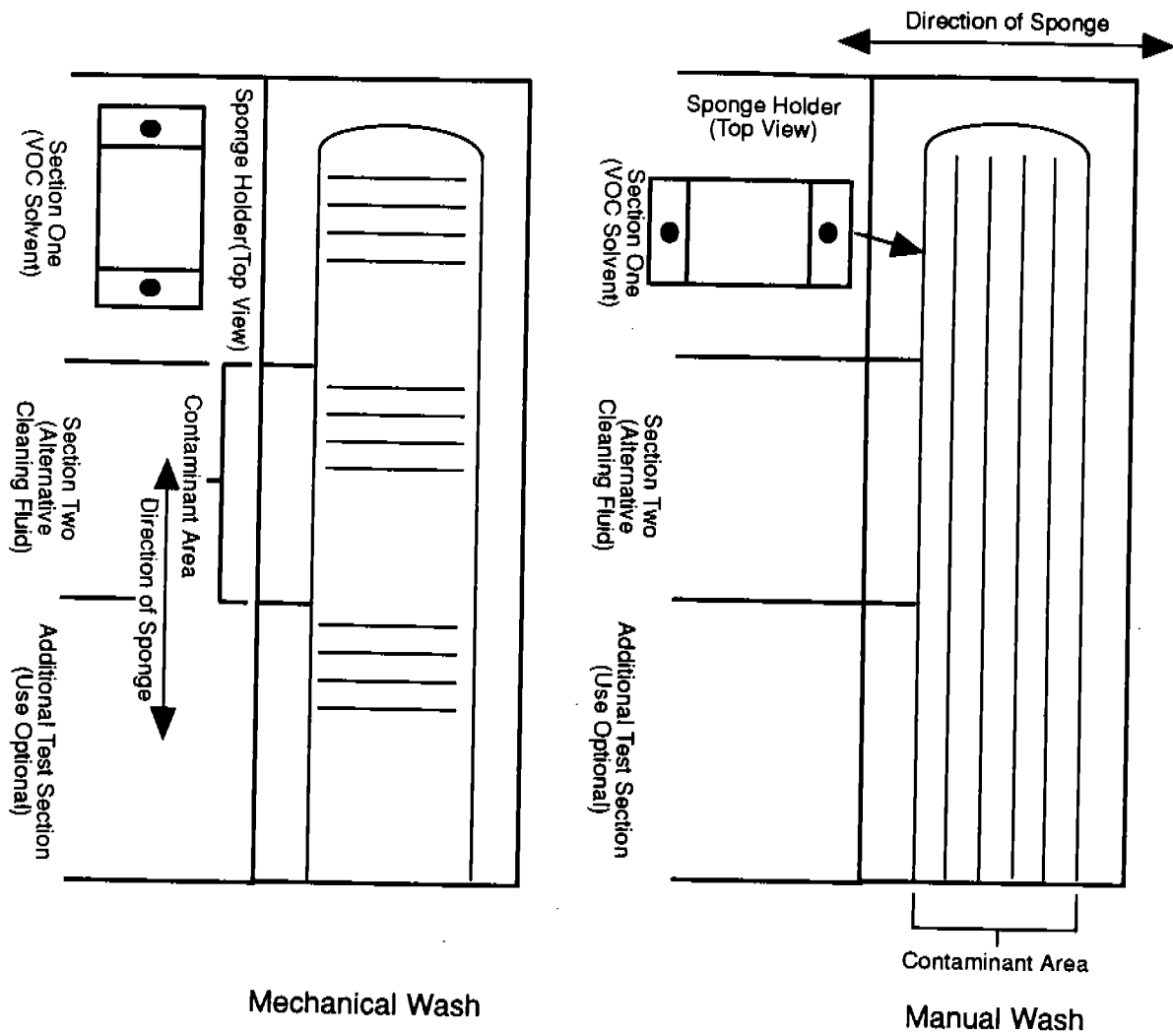

Figure F-2. Panel layout and brush holder diagram

100 cycles, stop and record the number of cycles before proceeding to 6.5.

F.6.4 Mechanical Method

1. Place the sponge and holder at one end of the panel so that its long axis is parallel to the length of the panel (see Figure F-2). Attach the sponge and holder to the cable of the washability machine. Allow the sponge to travel a maximum of 100 cycles. If all the contaminants are removed prior to 100 cycles, stop and record the number of cycles before proceeding to 6.5.

2. Remove the test panel and evaluate the condition of each in the path of the sponge and rate as follows:

- a. Worse than existing solvent
- b. As good as or better than existing solvent

When a contaminant is removed prior to 100 cycles, note the number of cycles in which each contaminant was removed.

F.7 REPORT

F.7.1 Report the Following Information

1. Type of contaminants, solvents, or cleaning solutions, and washing method used and the results obtained in 6.5.
2. Any contaminants that were removed in less than 100 cycles, and
3. Any deviation from the recommended procedure.

F.8 PRECISION AND BIAS

1. Precision — Unknown.
2. Repeatability — Unknown.
3. Reproducibility — Unknown.
4. Bias — Unknown.

APPENDIX G.
PROCEDURES FOR DETERMINING VOC EMISSIONS FROM
SPRAY GUN CLEANING

APPENDIX G.

PROCEDURES FOR DETERMINING VOC EMISSIONS FROM SPRAY GUN CLEANING

This appendix presents procedures for analyzing cleaning solvent usage and emissions for several subcategories of the spray gun cleaning unit operation system. This appendix focuses on spray gun cleaning for two reasons. First, more quantifiable data are available for this unit operation than for any of the other eight unit operations identified by this study. Second, as noted in Chapter 2, more emissions are associated with this unit operation than with any of the others. Similar analyses could be developed for the other UOS's.

A total of six subcategories were developed, based on the cleaning procedure used. Four are for cleaning manual guns and two are for cleaning automatic guns: (1) uncontrolled manual cleaning, (2) manual cleaning with collection of "once-through" solvent, (3) manual cleaning with recirculated solvent, (4) cleaning manual guns with a commercial gun washer, (5) automatic cleaning with collection of "once-through" solvent, and (6) automatic cleaning with recirculated solvent. In most cases, the plant has a choice, and the choice affects both the usage and emissions. Information from this study is used to illustrate each of the subcategories, and usage and waste data from several plants are used in example material balance calculations for most subcategories.

A State agency, over a period of time, could receive sufficient information on solvent usage for cleaning spray guns that it would be able to develop usage factors, preferably per unit area cleaned, with some confidence that they are

representative of the subcategories. Subsequently, those usage factors would provide a powerful tool with which to screen future reports on solvent usage. For example, if one knew with some confidence that to clean a gun generally required from 4 to 6 pints per cleaning cycle and someone reported 2 (or 10), then the State would be interested in knowing more about how that facility did so well (or poorly).

A State agency could also develop emissions factors for each subcategory by using the usage (and waste) information from facility reports in the appropriate material balances. The emissions factors would allow the State to quantify the emissions associated with each cleaning procedure and rank the procedures.

The remainder of this chapter has five sections. Section G.1 describes the components within the spray gun cleaning UOS subcategories and the important factors that must be considered to secure complete material balances for each. Section G.2 describes the four UOS subcategories for cleaning manual spray guns. One case study is reported for the first subcategory and three are reported for the second. No site specific case study on commercial gun washers was available, but data from an emissions test is presented. Section G.3 describes the two UOS subcategories for cleaning automatic equipment and presents information about cleaning automated spray guns in the metal furniture and automotive industries. Section G.4 compares the waste collection and emissions data for cleaning manual and automatic guns. Section G.5 contains information on spray gun cleaning UOS costs. Section G.6 contains references.

G.1 DESCRIPTION OF SPRAY GUN UNIT OPERATION SYSTEM

To estimate emissions associated with cleaning a spray gun, it is recommended that a material balance around a UOS be considered for that purpose. A spray gun UOS consists of the spray gun and ancillary equipment like hoses or paint cups that are cleaned at the same time as the gun. It should also include solvent and waste storage vessels. The cleaning activities include purging the gun; purging the hose or flushing the paint

cup (depending on the painting equipment used); and wiping the exterior of the gun (and the cup, if so equipped).

Cleaning of the exterior surface is an integral activity inherent when a gun washer is used. Therefore, to compare emissions from different cleaning requires on an equal basis, all spray gun UOS's must consider both external and internal cleaning. A UOS may include more than one spray gun (i.e., multiple guns that are cleaned by the same procedure and with the same solvent can be included in one UOS).

As described above, six general subcategories for spray gun cleaning UOS's were developed. When no waste solvent is collected, the uncontrolled subcategory, the emissions equal usage, and only the quantity of solvent used is needed to estimate emissions. If waste is collected, as in subcategories 2 through 6, three additional factors must be considered for an accurate estimate of emissions. These are (1) the total amount of spent solvent generated, (2) the contaminant content of the spent solvent, and (3) any solvent contribution from the paint. Each of these subcategories is discussed further in Sections G.2 and G.3.

G.2 CLEANING MANUAL SPRAY GUNS

This section describes the four manual spray gun cleaning UOS subcategories. Information from four case studies is summarized. Analyses include (1) estimates of usage and emissions factors normalized for the number of cleaning cycles and the surface area cleaned and (2) the effect of the remedial alternatives on emissions, solvent usage, and waste generation. Although these case studies reveal useful information, none is complete. All include some assumptions because none of the plants maintained all of the data needed to complete a rigorous material balance. Appendix B includes descriptions of operations and an example material balance calculation for a spray gun UOS from one of the case study plants.

G.2.1 Uncontrolled Emissions (Subcategory No. 1)

Uncontrolled emissions is the term used when all of the solvent used for cleaning a spray gun evaporates (i.e., no spent solvent is generated); emissions equals usage. Figure G-1 shows how the unit operation (cleaning of a spray gun) and associated potential sources of emissions created by cleaning can be considered as a system (UOS) for the purposes of quantifying the resulting emissions. The material balance for this UOS, assuming the solvent is 100 percent VOC, is shown in equation 1:

$$V_o = V_1 + V_2 + V_3 + V_4 + V_5 = S_1 \quad (1)$$

where:

V_o = total VOC emissions, lb/yr

V_1, V_2, V_3, V_4, V_5 = Emissions from individual activities within the UOS, lb/yr

S_1 = total weight of solvent usage, lb/yr

The time frame in the material balance is arbitrary; in this case, an annual basis was used.

The first action within the UOS is transfer of solvent from a storage drum or tank to the painting work station. This can be accomplished by transferring a portion to a solvent bucket, as shown in Figure 4-1. Some plants may have a solvent line from the storage tank to the paint work station. A line would eliminate the possibility of spillage between the storage drum and the work station, thereby offering a distinct advantage over manual transportation in a open bucket.

The second action is the actual cleaning activity, e.g., use of the solvent to purge the gun, flush the paint cup for a siphon- or gravity-feed gun, flush the hose for a pressure-feed system, and wipe the exterior of some or all components. The third action is post-cleaning activity, where more solvent evaporates. Purge solvent may be discharged from the gun directly into the air or into either a container or a wastewater

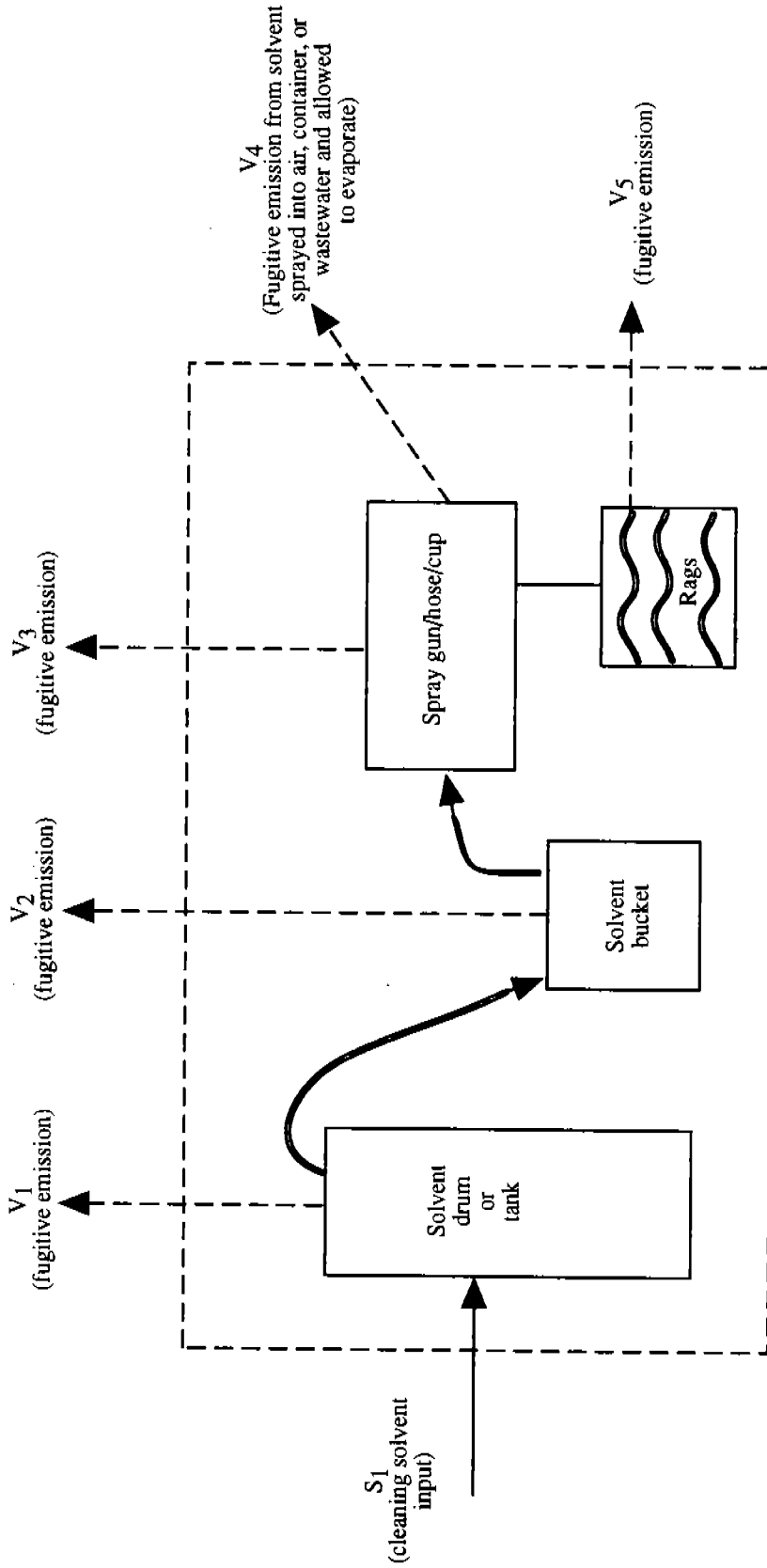

Figure G-1. Schematic of uncontrolled spray gun cleaning unit operation system (spent solvent directly released to the atmosphere).

system from which it evaporates. Rags used to wipe the exterior surfaces may be subsequently handled in such a way that the spent solvent is lost before it can be collected.

The only VOC input to the UOS is in the cleaning solvent (S_1). Specific records of the amount of cleaning solvent used in the UOS provide the best data for use in the material balance. Alternatively, estimates may be needed if detailed (UOS-specific) records are not kept. When usage is known in gallons, it must be multiplied by the VOC content of the solvent (lb VOC/gal solvent) to determine the amount of VOC that enters the UOS.

Outputs consist of emissions from the storage tank, solvent bucket (or fittings in a solvent line), surface of cleaned components, and evaporation of spent solvent (V_1 through V_5). Collectively, the VOC emissions (V_0) are equal to the usage because no waste solvent is collected in the rags.

One plant (Plant I) in the electrical components industry reported uncontrolled cleaning procedures for a siphon-feed gun. The plant did not maintain records of solvent usage for this UOS but estimated that the gun is cleaned 500 times per year (based on cleaning at the end of each of two operating shifts per day, 5 days per week, and 50 weeks per year). To clean a gun, the painter adds about a pint (0.93 lb) of lacquer thinner to the paint cup and sprays it into the air in an uncontrolled spray booth. Therefore, annual purge usage and emissions are equal, about 0.93 lb VOC per cleaning cycle and 464 lb/yr. The exterior of the gun and cup are also wiped occasionally with solvent, but the amount of solvent used for this purpose was not reported.^{1,2}

The procedure used by this plant appears typical for cleaning this type of gun and is common to many industries, including automobile refinishing shops. Estimates of the amount of solvent used range from about 0.6 to 1.8 lb/cycle (based on a VOC content of 7.3 lb/gal).^{3,4} The cleaning cycle is used as normalizing parameter because it is available, but the time for cleaning would be a better parameter.

G.2.2 "Once-Through" With Collection of Spent Solvent
(Subcategory No. 2)

One alternative that may reduce gun cleaning emissions is to collect spent solvent for disposal or other reuse. When spent solvent is collected after a "once-through" cleaning, emissions are calculated by subtracting the amount of VOC in the collected spent solvent from the amount used. The extent of emissions reduction will depend on the care and skill of operator and how well the collection container is sealed.

G.2.2.1 Description of the UOS. Figure 4-2 shows how the boundary was established around the UOS, the actions or steps inside the UOS, and the input and output streams that cross the boundary. Congruities between this subcategory and the uncontrolled case (Figures G-1 and G-2) are the solvent storage, solvent transfer to the work station, and solvent use in cleaning. The two primary differences are: (1) spent solvent is collected, and (2) the total solvent collected must be adjusted to correct for the paint solvent that is associated with the collected paint nonvolatile matter.

Emissions occur from the same locations in both this UOS, shown in Figure G-2 (V_1 through V_5), and the uncontrolled UOS (Figure G-1). Additional locations for emissions shown in Figure G-2 include paint collection containers, spent solvent collection buckets, and spent solvent drums or tanks (V_6 through V_8). Figure G-2 also shows one VOC input stream (S_1) and one spent solvent output stream (W for waste disposal).

Measuring and recording the amount of solvent used and the amount collected for waste disposal provide the best data for use in the material balance. Further, samples of the waste stream should be analyzed periodically for contaminants (nonvolatile material) and non-VOC's (e.g., all material not determined to be a VOC by EPA Method 24), and the difference is the VOC content of the stream. In the absence of UOS-specific records and sample analyses, estimates will be needed to complete the material balance.

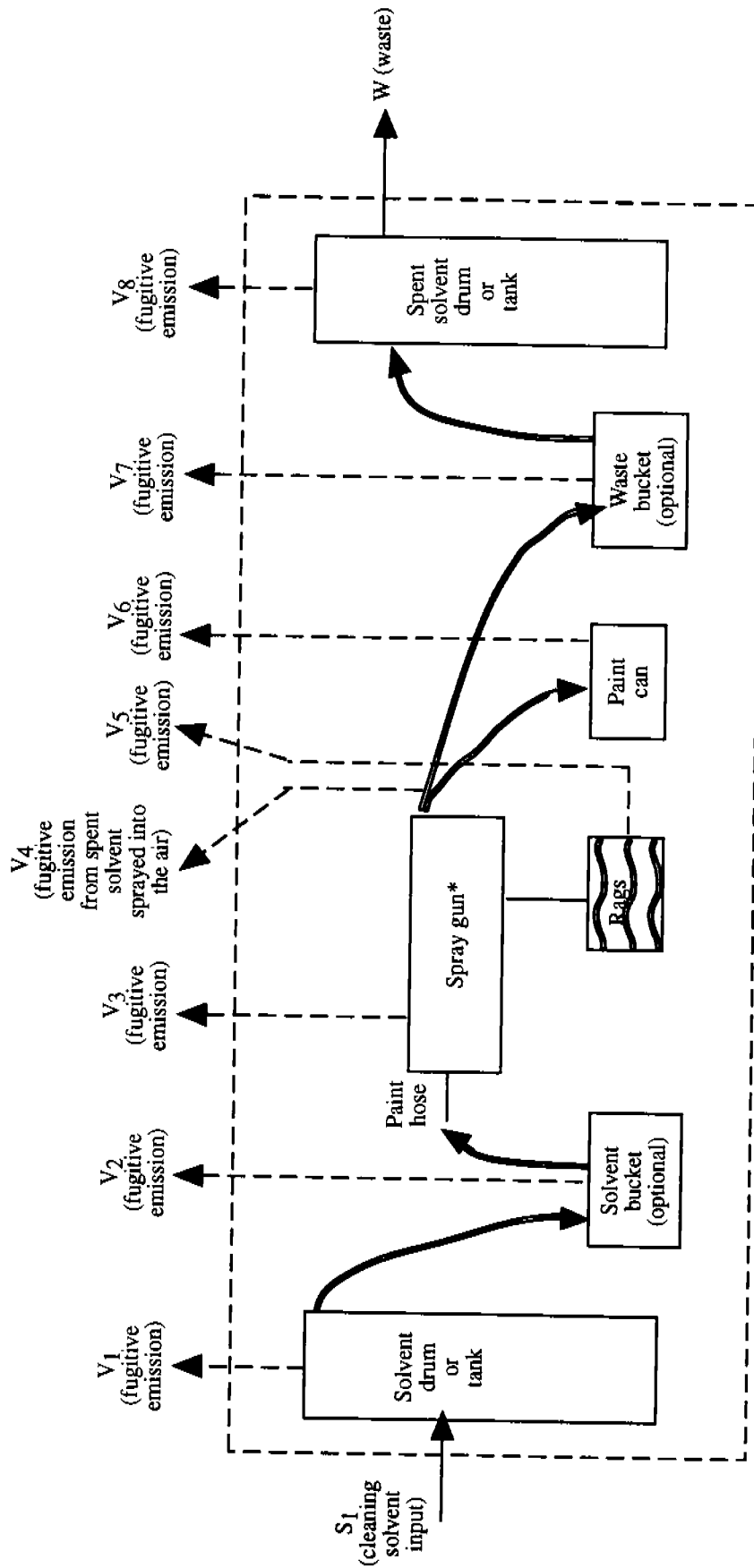

*NOTE: Thinning solvent associated with the paint nonvolatile matter removed from the hose and gun while cleaning must also be included in the material balance.

Figure G-2. Schematic of manual spray gun cleaning unit operation system with once-through solvent use and collection of spent solvent.

The material balance for this UOS is shown in Equation 2:

$$V_O = V_1 + \dots + V_8 = S_1 - (W) \times (x_w) \quad (2)$$

where:

W = total weight of waste solvent, lb/yr

x_w = VOC weight fraction of waste solvent, lb VOC/lb waste

Because "wet" paint (residual matter from painting) is removed during the purge, the cleaning solvent emissions calculated from Equation 2 are underestimated by the amount of paint solvent collected in the spent solvent container (Figure G-2). Thus, the cleaning solvent emissions have to be increased by the amount of collected paint solvent:

$$V_C = V_O + W_P \quad (3)$$

where:

V_C = cleaning solvent emissions, lb VOC/yr

W_P = weight of collected paint solvent, lb VOC/yr

If the cleaning and paint solvents are different, the amount of collected paint solvent can be determined by analysis of the waste; otherwise, the amount must be estimated. When the composition of the solvent fraction of the waste is unavailable or the cleaning solvent and paint solvent are identical, the collected paint solvent cannot be determined. In these cases, the UOS is modified to include the amount of paint solvent originally associated with the paint solids in the waste stream (P) as an input. (The amount of collected paint solids is assumed to be equal to the amount of nonvolatile matter in the waste stream.) The material balance is modified to calculate the total cleaning and paint solvent emissions by adding P to the right side of Equation 2. Assuming the cleaning solvent and paint solvents have similar volatilities, equal portions of both solvents are assumed to evaporate. The amount of cleaning solvent that evaporates is then estimated by multiplying the total emissions by the ratio of the cleaning solvent input to the total cleaning and paint solvent input.

The VOC paint solvent associated with the nonvolatile matter in as-applied paint comes from both the purchased paint and thinning solvent added at the plant. The amount from the purchased paint is estimated from the ratio of solvent to nonvolatile matter in the purchased paint. The amount of additional thinning solvent is estimated based on knowledge of the dilution ratio and the VOC weight fraction of the purchased paint. This procedure for estimating the amount of paint solvent originally associated with the nonvolatiles in the waste stream (P) is expressed mathematically in Equation 4.

$$P = (W) \times (1 - X_w) \times (R_p) \times (1 + R_T/X_p) \quad (4)$$

where:

R_p = ratio of VOC to nonvolatile matter in the purchased paint, lb VOC/lb nonvolatile matter

X_p = VOC weight fraction of purchased paint, lb VOC/lb paint

R_T = weight ratio of thinning VOC solvent added to a pound of purchased paint, lb VOC/lb paint

G.2.2.2 Case Studies. Table G-1 summarizes the use of cleaning solvent at three plants that conduct once-through cleaning according to the procedure shown in Figure G-2.⁵⁻¹⁴ Each plant cleaned two spray guns. One plant has siphon-feed guns. About 1 pound of solvent is used for cleaning a siphon-feed gun, about the same as for the siphon-feed example described in Section G.2.1 and Figure G-1. The other two plants have pressure-feed systems with 5 ft and 107 ft of hose, respectively. Usage there is higher and is a function of the length and area of hose, although not in direct proportion. The operating procedures and the calculations used to develop these usage factors for Plant L are shown in Appendix H.

TABLE G-1. SUMMARY OF CLEANING SOLVENT USAGE AT PLANTS THAT CONDUCT ONCE-THROUGH MANUAL CLEANING⁵⁻¹⁴

Plant	No. of guns in UOS	No. of cleaning cycles per year	Hose length, ft	Area cleaned, ft ² /cycle	Cleaning solvent usage		
					lb/yr	lb/cycle	lb/ft ²
J	2	1,476	0 ^a	0.9	1,459	0.99	1.1
K	2	2,040	5 ^b	N/A	3,781	1.85	N/A
L	2	796	107 ^b	5.5	12,292	15.4	2.8

^aThis plant uses siphon-feed gun.

^bThe hose O.D. is 0.25 in.; ID is 0.1968 in.

N/A = not available.

Table G-2 summarizes the spent solvent parameters for the only plant that provided sufficient information to allow estimation of the solvent contribution from the paint.⁵⁻⁷ The plant maintains segregated waste records for this UOS, and an analysis was made of a small sample of the waste (18.3 percent paint contaminants). The plant uses several paints. Data were available for only one of the several paints used in the plant. According to the MSDS, its VOC content is between 50 and 70 percent; the remaining 30 to 50 percent is nonvolatiles. A nonvolatiles content of 40 percent was used for estimating the contribution of paint solvent in the waste. The plant also adds 0.022 lb of virgin thinning solvent per lb of paint.

Emissions at this plant were calculated using equations 2 through 4 as described in Appendix H. As shown in Table G-2 (and in Appendix H), the emissions for the paint spray gun were calculated to be 2,370 lb/yr. Normalized emission factors for this case are 3.0 lb/cleaning cycle and 0.5 lb/ft² of area cleaned. The emissions per cleaning cycle are higher than those for the uncontrolled example presented in Section G.2.1, perhaps because this is a pressure-feed gun system. However, the emissions per unit area cleaned may be similar or even lower (the area cleaned was not reported for the uncontrolled example, but it may be similar to that for Plant J). Also, because spent

solvent is collected, the emissions for this plant are only 25 percent of usage rather than 100 percent. Appendix H presents the calculations for this case study.

TABLE G-2. SUMMARY OF SPENT SOLVENT COLLECTION AND EMISSIONS FROM CLEANING THE PAINT SPRAY GUN AT PLANT L⁵⁻⁷

Parameter	Quantity
Spent solvent collected	
Total, lb/yr	16,820
VOC, lb/yr	13,742
Paint nonvolatiles, lb/yr	3,078
Associated paint solvent, lb VOC/yr	4,784
Emissions	
lb/yr	2,370
lb/cycle	3.0
lb/ft ²	0.5

G.2.3 Recirculating Cleaning Solvent (Subcategory No. 3)

A second alternative that clearly reduces usage and may reduce gun cleaning emissions is to recirculate solvent for additional gun cleanings. As shown in Figure G-3, this results in a simpler UOS than that for subcategory No. 2. The steps up to cleaning the gun are the same for both. In this case, however, spent solvent is returned to the solvent vessel (either the solvent bucket, if used, or directly to a solvent tank). This recirculation can be accomplished by aiming the gun to spray the spent solvent directly into the solvent vessel or into a basin that drains into the container.

The material balance for this subcategory is the same as for subcategory No. 2 (Equation 2). However, there are fewer emission locations, which may result in lower emissions. Because of recirculation within the UOS, this subcategory also has the potential to achieve significantly lower usage and waste generation. Although this cleaning procedure was identified at one of the plants that responded to the EPA survey, the reported data were inadequate to quantify the material balance.

G.2.4 Cleaning With Commercial Gun Washers (Subcategory No. 4)

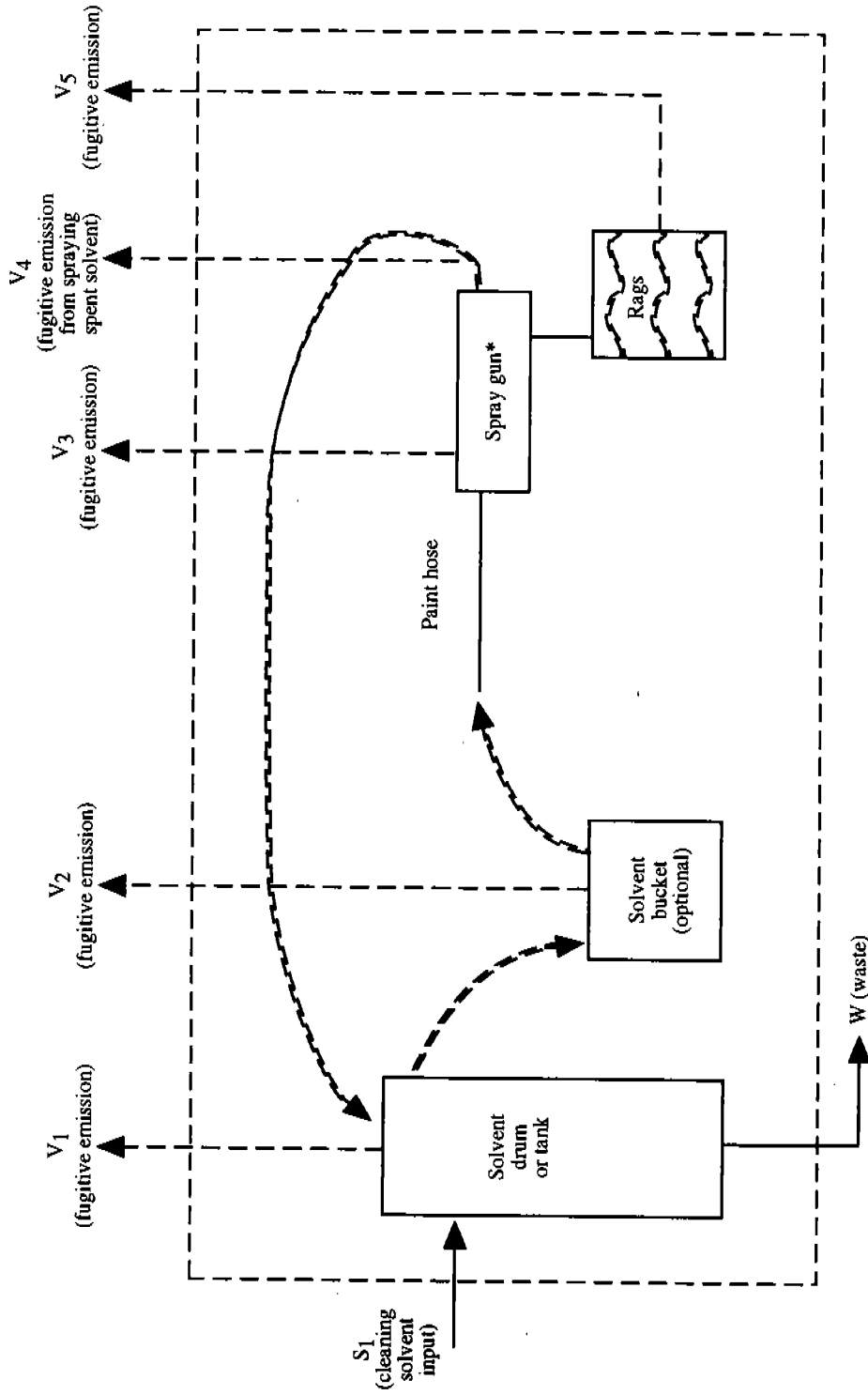

*NOTE: Thinning solvent associated with the paint nonvolatile matter removed from the hose and gun while cleaning must also be included in the material balance.

Figure G-3. Schematic of manual spray gun cleaning unit operation system with recirculated solvent.

Equipment that is designed specifically for cleaning spray guns, sprays cups/pots from siphon- or gravity-feed systems, and even flexible paint hoses is available from a number of manufacturers. Such equipment is typically referred to as a gun washer. Most manufacturers produce an enclosed cabinet in which solvent is both sprayed over the gun and cup and drawn through the gun. Hose flushing capabilities are often options that consist of appropriate fittings on the outside of the gun washer to which a hose can be connected. At least one company makes an open gun washer. Figures G-4 and G-5 present diagrams of closed and open gun washers, respectively.^{4,15,16}

The schematic for a gun washer UOS is shown in Figure G-6. The material balance is the same as that for subcategory No. 2 (Equation 2). All gun washers recirculate solvent, as in Subcategory No. 3, but because the recirculation occurs inside the gun washer, the steps are not diagramed in Figure G-6. Rags are illustrated in Figure G-6 because they may be used to wipe the exterior of a hose. All other exterior surfaces are cleaned within the gun washer.

Because gun washers recirculate solvent, they can achieve significant usage and emissions reductions relative to uncontrolled cleaning (subcategory No. 1). One manufacturer claims usage reductions of 80 to 90 percent, and another calculates payback time for automotive refinishing shops based on "a very conservative estimate" of about 50 percent.^{4,15}

Very little case data on washers was available. One automobile engine manufacturing plant reported that spent solvent collection from a gun washer was 80 percent of the annual usage (emissions were only 20 percent). This value was based on judgement, not measurement, and they believe it is conservatively low.^{17,18} However, it does not account for paint solvent collected in the waste. Also, the plant was unable to provide the nonvolatile matter content of the waste, the number of cleaning cycles, or the area cleaned. These data are critical to calculating the amount of paint solvent in the waste, emissions,

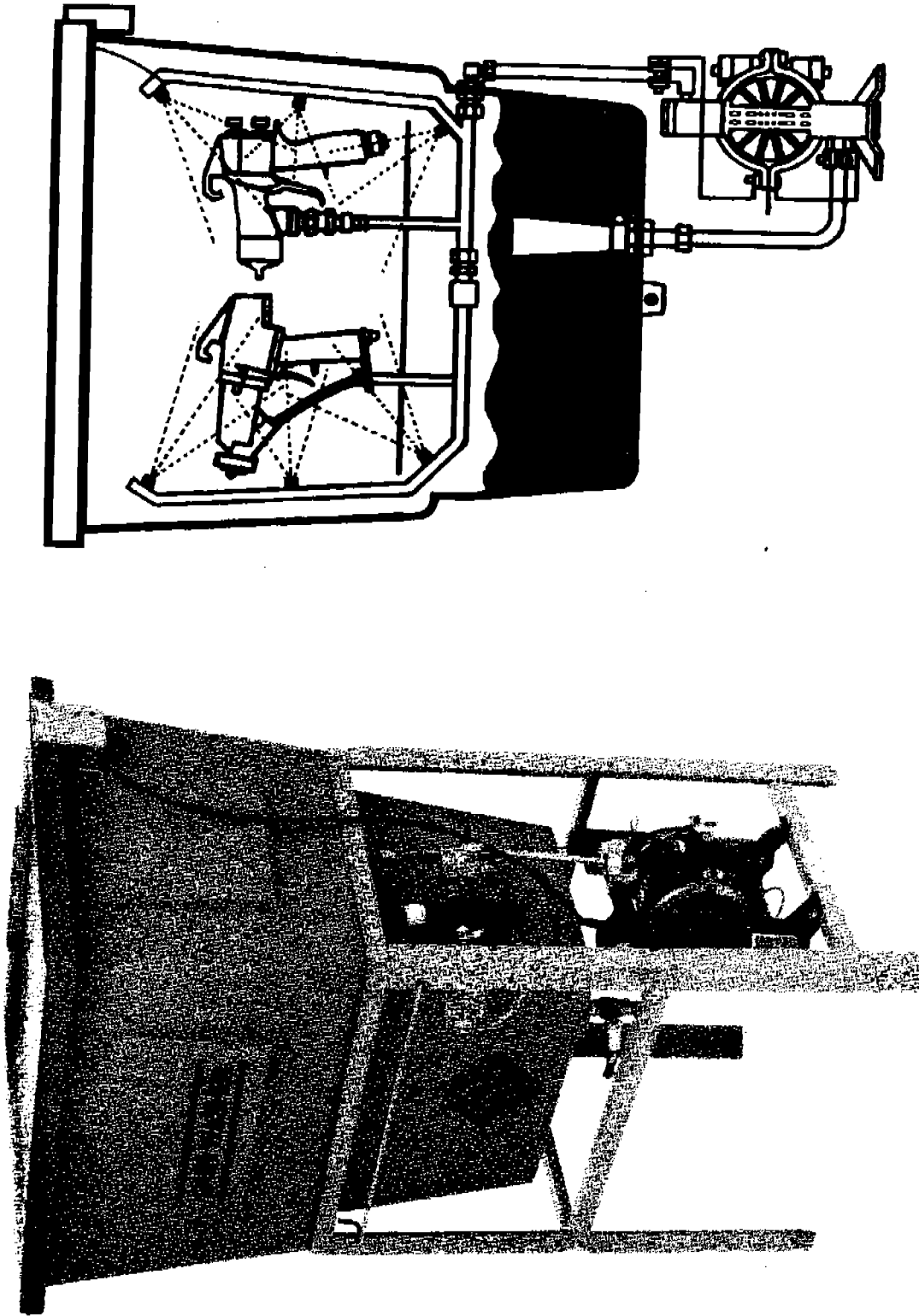

Figure G-4. Picture and schematic of typical closed gun cleaner.⁴

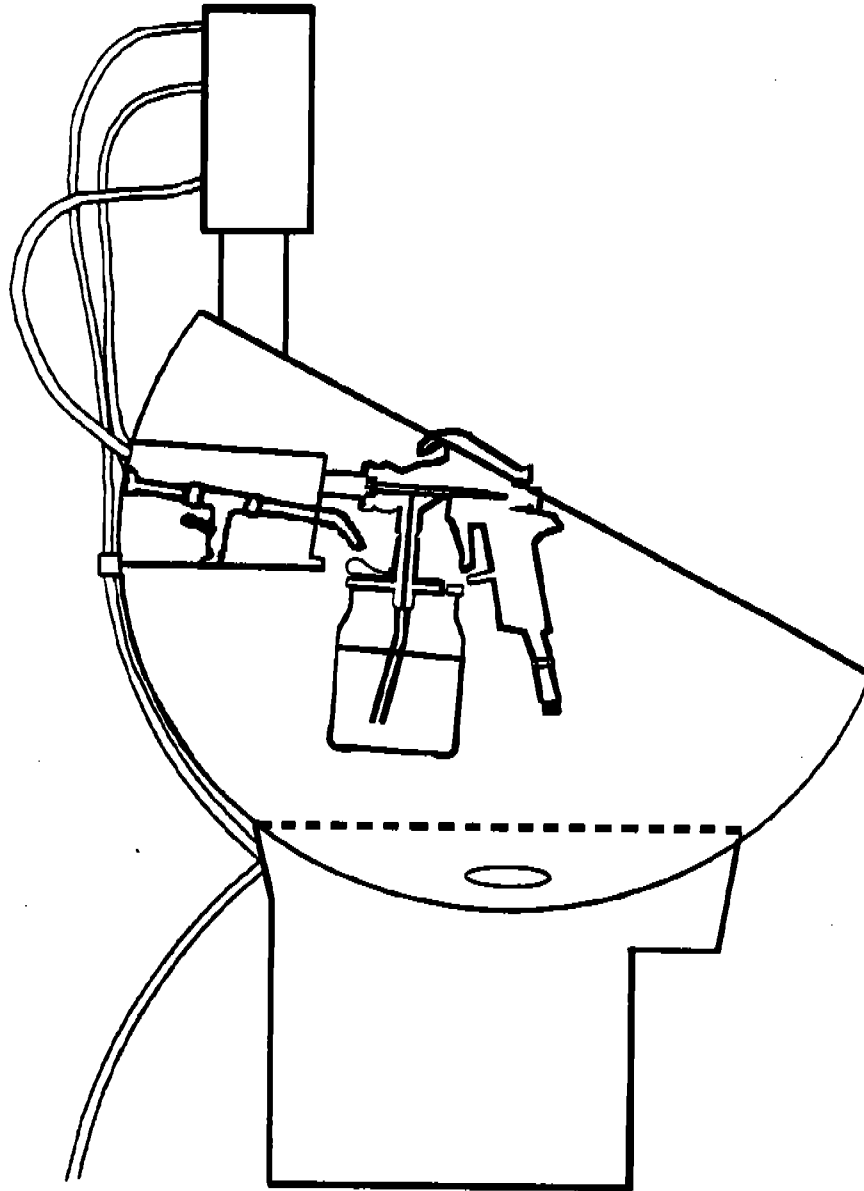
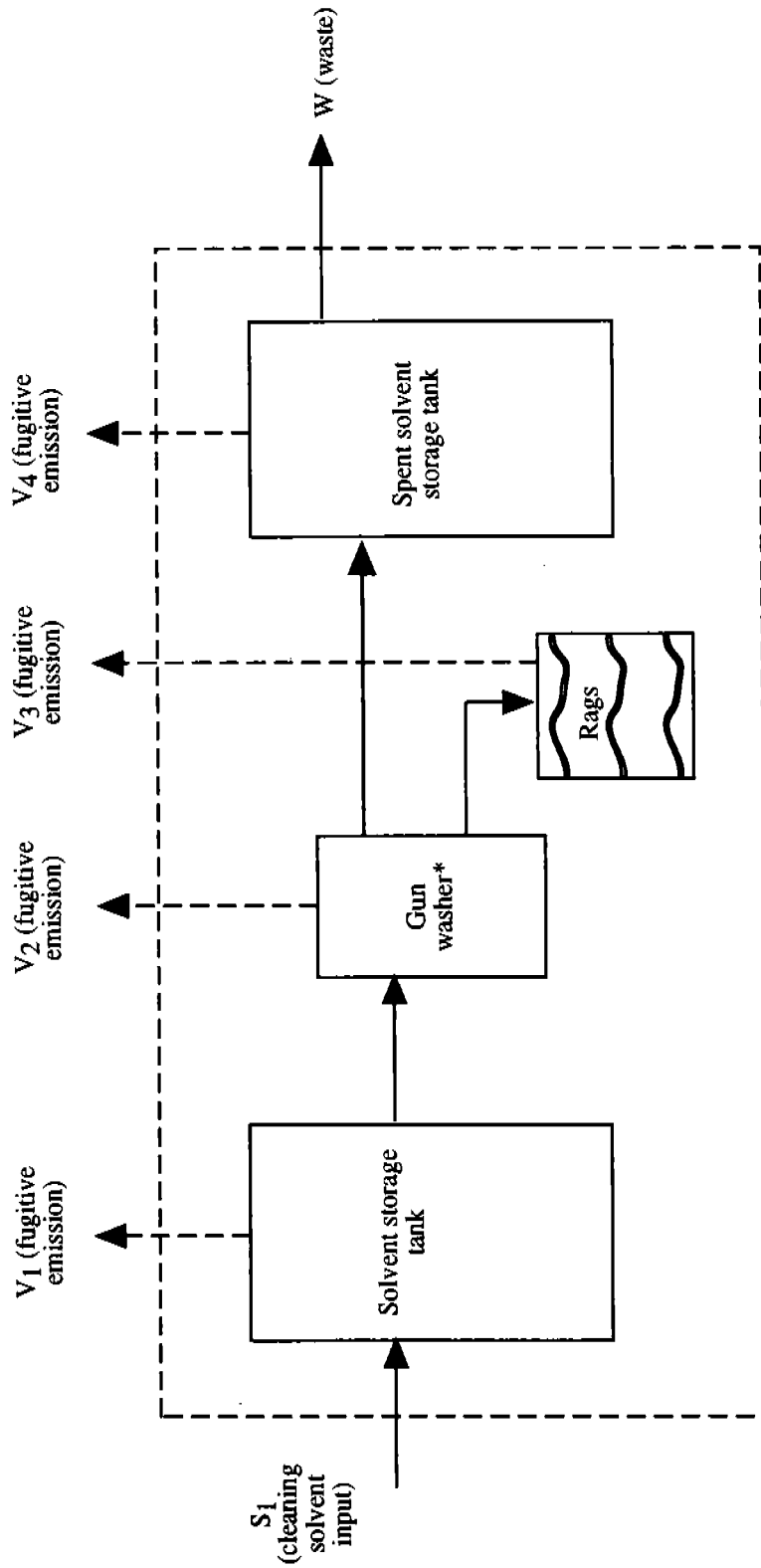

Figure G-5. Typical open gun cleaner.¹⁶



*NOTE: Thinning solvent associated with the paint nonvolatile matter removed from the hose and gun while cleaning must also be included in the material balance.

Figure G-6. Schematic of gun washer unit operation system.

and normalized usage and emissions factors. Consequently, the solvent efficiency for gun washers cannot be compared to the other subcategories.

In 1990, an emissions test of gun washers was commissioned by Safety-Kleen, using a protocol developed by SCAQMD. According to the test report, one clean gun and paint cup were used in each test run, BASF lacquer thinner was used as the solvent, and manufacturer-recommended operating procedures were followed. The test did not examine hose cleaning.¹⁹

Surprisingly, the test results showed higher emissions from the closed gun washers than from the open units. These results were disputed by one manufacturer (of closed units) because, he reported, outdated closed models were tested, and the operating procedures used for the open unit were significantly simpler than recommended by the manufacturer.²⁰ The potential improvement of newer closed models or of using different operating procedures for the open models are unknown. The most conservative (i.e., highest) estimate, however would use the existing data on closed gun washers. The average active losses (emissions during the cleaning cycle) for these units were about 32 g/cycle (0.07 lb/cycle), and passive losses (emissions while the unit is idle) were about 2.8 g/hr (0.0062 lb/hr).¹⁹

Based on these emission factors, the emissions from the uncontrolled plant described in Section G.2.1 could be reduced from 460 to 90 lb/yr ($0.07 \times 500 + 0.0062 \times 8,760 \times 0.99 = 90$); a reduction of 80 percent. The relative efficiency of a gun washer and the procedures for subcategory Nos. 2 and 3 cannot be determined without additional data.

G.3 CLEANING AUTOMATIC PAINT SPRAY SYSTEMS

Automatic spray systems are used in plants with repetitive painting requirements, particularly assembly line work. Just as when cleaning a manual gun, solvent may be used on a once-through basis (subcategory No. 5) or recirculated (subcategory No. 6). Descriptions of both subcategories are presented below. Also presented are case study data to illustrate the use of the

material balance for subcategory No. 6. No data are available for subcategory No. 5.

G.3.1 Description of UOS Subcategory Nos. 5 and 6

The UOS diagrams are shown in Figures G-7 and G-8. The primary difference between the cleaning procedures in these UOS's and those in Figures 4-2 and 4-3 is that the hose and part of the gun are purged with solvent that is not discharged through the nozzle. Rather, it is forced through a tube attached to the base of the gun and either collected for disposal or recirculated to the feed storage tank. Only a small, short burst exits the gun nozzle, and it evaporates. Minor fugitive losses may occur from fittings and during transfer to storage tanks. Solvent may also be used to clean the exterior of the guns and hoses, if they are not covered. Except for the number of emission locations, the material balance shown in Equation 2 for cleaning manual guns also applies to these subcategories.

G.3.2 Case Studies

Data from five plants (all of the same metal furniture company) were used to normalize usage and emission factors for cleaning automated spray guns for subcategory No. 6. Four plants in the automotive industry provided additional support data.

Several assumptions are included in this analysis. First, material balances for calculating emissions for these plants are based on the assumption that all of the reported data are for cleaning automatic equipment. This assumption was necessary because the plant cleans both automatic and manual guns, but the amount of solvent used for each purpose is not monitored. However, it was reported that "automatic systems predominate" at each plant. A second, related assumption is that all of the reported cleaning cycles and areas cleaned are for automatic equipment. This assumption was necessary because the plants identified only the totals, not the amount for each type of gun. Finally, the nonvolatile matter content of the paint as-applied

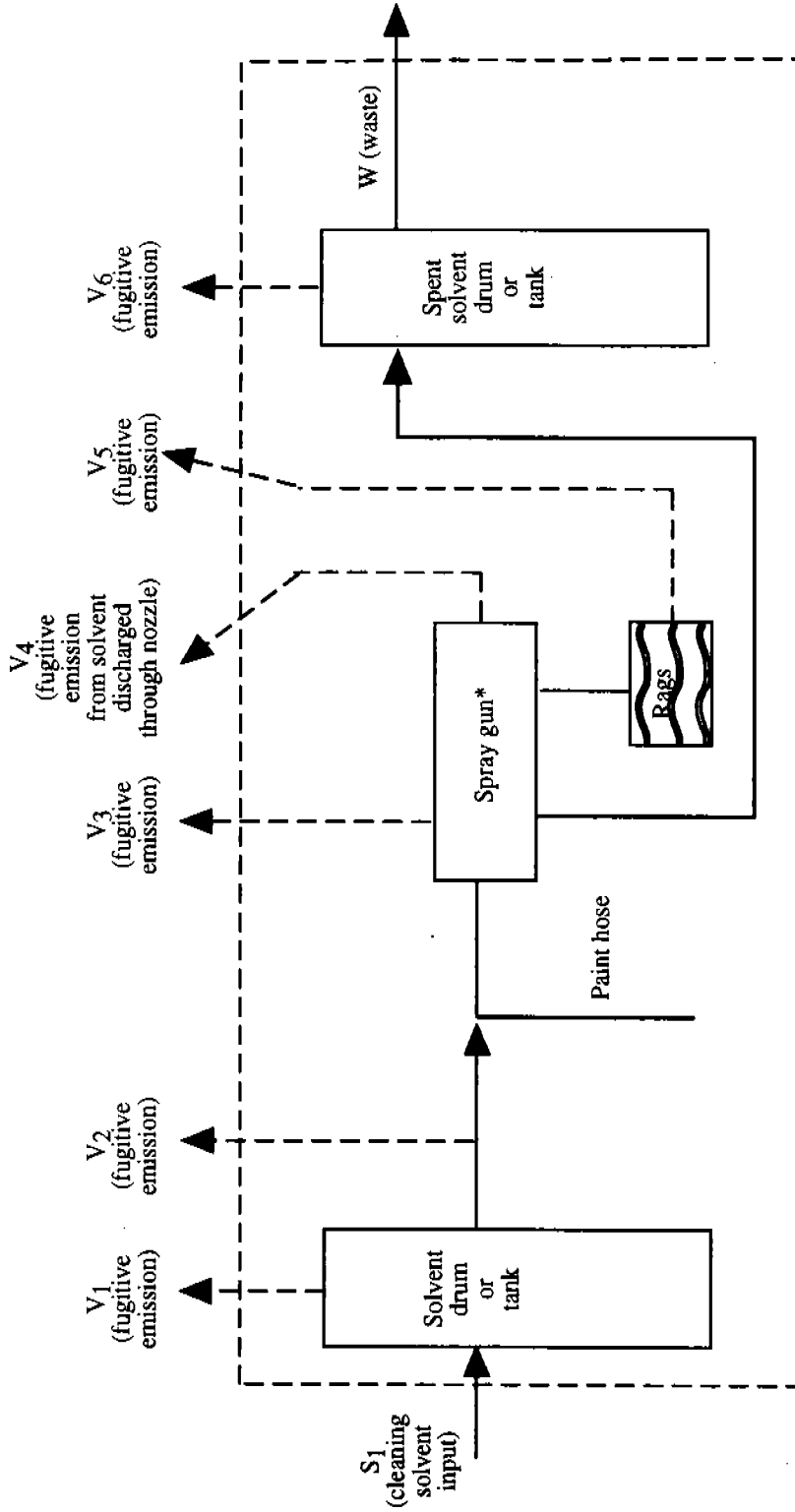

*NOTE: Thinning solvent associated with the paint nonvolatile matter removed from the hose and gun while cleaning must also be included in the material balance.

Figure G-7. Schematic of automatic spray gun cleaning unit operation system with "once-through" solvent use and collection of spent solvent (subcategory No. 5).

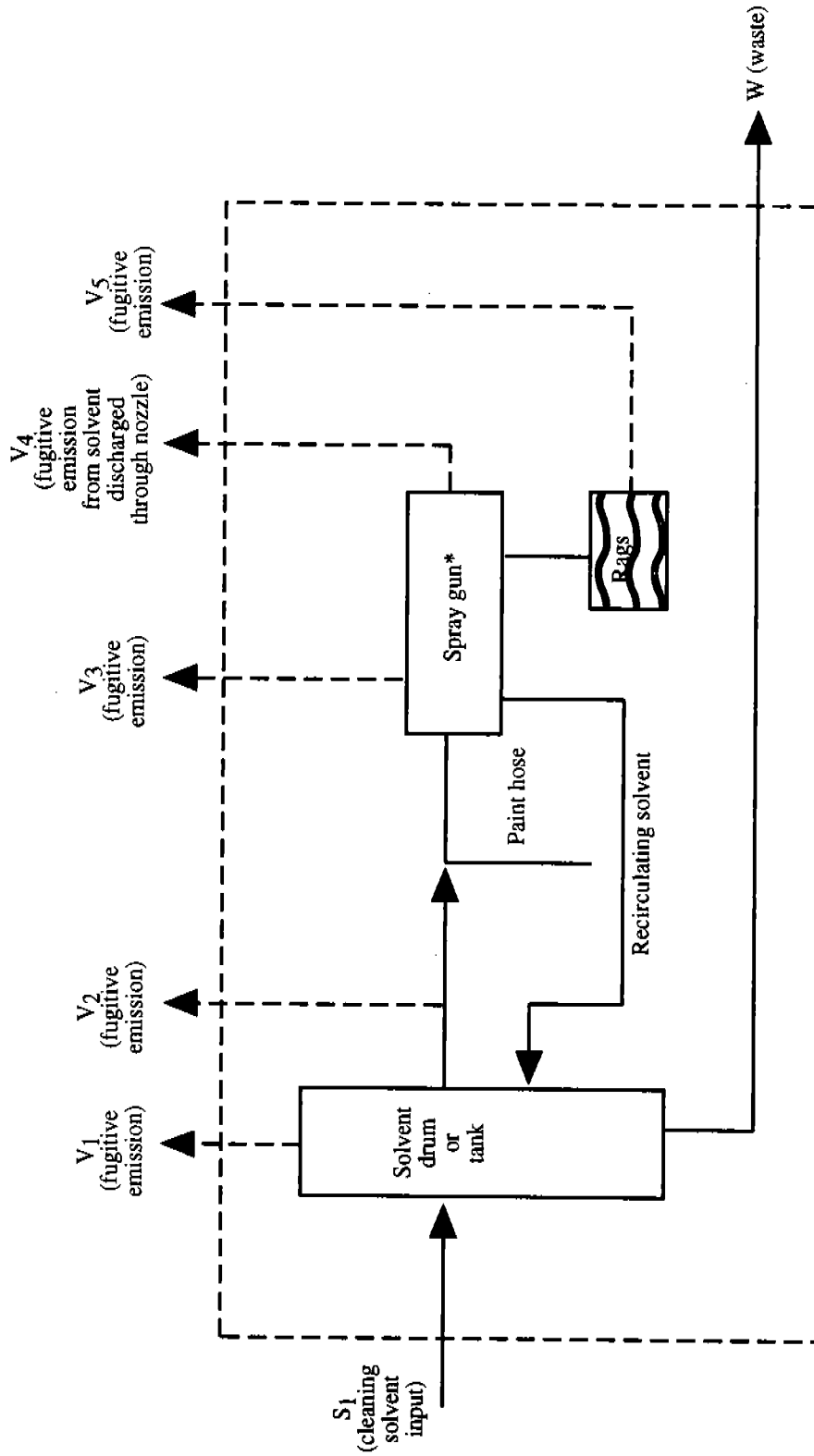

*NOTE: Thinning solvent associated with the paint nonvolatile matter removed from the hose and gun while cleaning must also be included in the material balance.

Figure G-8. Schematic of automatic spray gun cleaning unit operation system with recirculating solvent (subcategory No. 6).

was assumed in order to estimate the amount of paint solvent collected in the waste solvent.

G.3.2.1 Cleaning Solvent Usage. As shown in Table G-3, each of the five metal furniture plants reported the total number of cleaning cycles and the total cleaning solvent usage.²¹⁻²⁸ Assuming all of the usage and cleaning cycles are for cleaning automated equipment, the usage factors range from about 1 to 9 lb per cleaning cycle. This range is within the range of usage factors for manual cleaning noted above.

The five plants also reported the total surface area cleaned during each cycle. Table G-3 shows the usage factors range from nearly zero to more than 6 lb/ft² cleaned.²¹⁻²⁷ The reason is not clear, but perhaps because long lines may be purged simultaneously with the guns at two of the plants (the length of hose/line was not reported).²⁸ These values differ by a wider range than those for the manual cleaning in Section G.2.2.

These results suggest it is unlikely that combining manual and automatic gun cleaning significantly affected the usage factors for automatic cleaning. Assuming that the data industry provided are correct, these results would suggest that neither the number of cleaning cycles nor the area cleaned characterize usage by themselves. Other factors such as worker practices or the amount of paint that must be removed (i.e., because paints have different nonvolatile matter contents or because nonvolatile matter settled in the painting equipment) may also be important.

a. Collected Waste Solvent. According to each of the five metal furniture plants, the cleaning solvent is recirculated until the paint contaminants level in the collecting container reaches 33 percent. The spent solvent is then disposed. Four of the plants indicated that the amount of solvent in the collected waste is equal to 80 to 90 percent of the fresh cleaning solvent feed; the fifth plant indicated the amount is only about 50 percent.²¹⁻²⁴ The basis for these values (either records or estimates) is uncertain.

TABLE G-3. SUMMARY OF CLEANING SPRAY GUNS AT METAL FURNITURE PLANTS 21-28

Plant	Number of cleaning cycles per year	Area cleaned, ft ² /cycle	Cleaning solvent usage			Paint solvent, ton/yr ^a	Collected Solvent		Emissions		
			ton/yr	lb/cycle	lb/ft ²		ton/yr	% of all usage	ton/yr	lb/cycle	lb/ft ²
M	213,642	1.47	997	9.33	6.35	606	820	51	782	7.32	4.98
N	330,000	0.78	198	1.20	1.54	134	182	55	150	0.91	1.17
O	91,200	16.9	133	2.92	0.17	51	69	37	115	2.52	0.15
P	135,065	238	295	4.36	0.02	196	265	54	225	3.34	0.01
Q	16,250	1.45	42	5.18	3.57	25	34	50	33	4.10	2.82

^aBased on assumption that paint is 40 percent solids and 60 percent organic solvent (all VOC).

The plants did not determine the amount of paint solvent in the waste solvent, and they did not provide the nonvolatile matter content of the paint. Thus, it was assumed the paint as applied is 40 percent nonvolatiles. Using Equation 4 with $R_T = 0$, the paint solvent in the waste was estimated to range from 25 to 600 tons/yr, as shown in Table G-3. When these values were subtracted from the waste solvent, the cleaning solvent in the waste ranges from 37 to 55 percent of the total cleaning feed.

Similar information was obtained from four automotive assembly plants. These plants, which use solvent on a once-through basis, reported waste solvent collection to be about 85 percent of usage.^{29,30} The plants based these estimates on actual waste disposal records corrected for contaminant levels and on total usage rates corrected for estimated amounts used in booth cleaning. The amount of solvent contributed by the paint in the gun was not reported. It could not be estimated because the amount of contaminants in the waste was not reported. The actual solvent in the collected waste, then, is unknown, but certainly is less than the reported 85 percent.

G.3.2.3 Emissions. Based on the data and assumptions discussed above, the emissions factors for the metal furniture plants range from about 1 to 7 lb/cleaning cycle and nearly zero to 5 lb/ft². No data are available for direct comparisons with subcategory No. 3 (manual cleaning with recirculated solvent) or subcategory No. 5 (automatic cleaning with once-through solvent). However, the values from Section G.2.2 for Plant L, which cleans manual guns with once-through solvent, were well within these ranges. These data suggest there may be little difference in emissions between subcategory Nos. 2, 3, 5, and 6.

The official position of the American Automobile Manufacturers Association (AAMA) (formerly the Motor Vehicle Manufacturers Association [MVMA]) is that emissions from cleaning automatic robotic and reciprocating spray guns (and hoses between

color changers and the guns) are equal to about 10 percent of the solvent used.³¹ The basis for this statement is unclear.

A. AUTOMATIC VS. MANUAL CLEANING

Two automotive assembly plants reported recently switching from extensive use of manual guns to automatic equipment. They indicated that solvent collection rates were only 28 and 46 percent of the usage for the manual cleaning.³² The rates were low because the painters were purging the manual guns into the wastewater system. Since increasing their level of automation, one plant increased its waste collection from 46 to 87 percent of usage.³⁰ Usage was not reported, but assuming it did not change significantly, emissions must have been reduced. The number of cleaning cycles and area cleaned also were not reported, which precluded development of normalized usage and emissions factors for comparison of manual and automatic cleaning.

G.5 SPRAY GUN CLEANING UOS COSTS

This section presents estimated accounting system costs and cleaning costs under spray gun cleaning UOS subcategories 1 and 4 (i.e., uncontrolled and in an enclosed commercial gun washer) for Plant I. The accounting system costs are based on assumptions about recordkeeping requirements for Plant I and accounting system cost data presented in Chapter 5. The cleaning costs are also based on the operating data described in this appendix for Plant I. This is the only plant for which sufficient data are available to develop the cost analyses for both subcategories. All costs are in second quarter 1992 dollars. The accounting costs are shown in Table G-4, and cleaning costs for both subcategories are shown in Table G-5.

G.5.1 Accounting System Costs

The accounting system costs are assumed to be equal regardless of the cleaning procedure that is used. Purchased equipment costs are based on the average of costs for plants C, E, and G. Recordkeeping was assumed to require 5 minutes per cleaning cycle, and an identical amount of time was assumed for

TABLE G-4. SOLVENT ACCOUNTING SYSTEM COSTS
 FOR SPRAY GUN UOS AT PLANT I

Costing parameters	Costs
A. Total capital investment, \$	
1. Purchased equipment costs ^a	1,600
2. Installation ^b	0
3. Initial training ^a	<u>477</u>
	2,077
B. Direct annual costs, \$/yr	
1. Operating labor	500
-recording ^c	500
-data entry/analysis ^c	<u>500</u>
2. Maintenance labor and materials ^d	1,500
C. Indirect annual costs, \$/yr	
1. Overhead ^e	900
2. Administrative charges	41
3. Property tax	21
4. Insurance	21
5. Capital recovery	<u>347</u>
	1,330
D. Total annual cost	2,830

^aAverage of purchased equipment and training costs for Plants C, E, and G (assumes existing computer equipment can be used).

^bAssumed to be included in the purchased equipment cost.

^cAssuming 5 min/cycle, \$12/hr.

^dAssuming equal to recording operating labor.

^eEqual to 60 percent of labor and maintenance materials costs.

TABLE G-5. COSTS FOR CLEANING SPRAY GUNS AT PLANT I

	Subcategory No.1	Subcategory No.4
A. Total capital investment, \$		
1. equipment	0	2,000
2. taxes & freight	0	160
3. installation	<u>0</u>	<u>200</u>
	0	2,360
B. Annual costs for cleaning		
1. Direct annual costs, \$/yr		
a. cleaning solvent	247	49
b. operator labor	1,000	200
c. supervisory labor	150	30
d. maintenance labor	0	104
e. maintenance materials	0	104
f. waste disposal	0	21
2. Indirect annual costs, \$/yr		
a. overhead	690	263
b. property taxes, insurance, and administrative charges	0	94
c. capital recovery	<u>0</u>	<u>384</u>
	2,087	1,249
C. Accounting system cost, \$/yr ^a	2,830	2,830
D. Total annual cost, \$/yr	4,917	4,079
E. Savings achieved with control alternative, \$/yr	N/A	838

N/A = Not applicable.

^aSee Table 5-3 for derivation of accounting costs.

data entry and analysis. Indirect annual costs are based on the procedures described above. The resulting total annual cost is about \$2,800.

1. Costs for Uncontrolled Cleaning

Uncontrolled costs consist of solvent and labor costs. As noted in Section G.2.1, Plant I uses 464 lb/yr of cleaning solvent for cleaning two guns. The plant also reported 500 cleaning cycles per year, a solvent unit cost of \$3.86/gal, and a VOC content of 7.26 lb/gal.^{33,34} The operator labor time needed to clean the guns was assumed to be 10 minutes per cleaning cycle.^{35,36} The operator wage rate was assumed to be \$12/hr. Based on these data, the solvent cost is \$247/yr, and the operator labor cost is \$1,000/yr. Based on OAQPS cost factors, supervisory labor costs were estimated to be equal to 15 percent of the operator labor costs, and overhead was estimated to be equal to 60 percent of all labor and maintenance materials costs.^{37,38} As shown in Table G-5, the resulting total annual cost is about \$2,100/yr.

G.5.3 Gun Washer Costs

List prices for enclosed gun washers range from about \$800 to \$2,500. This analysis uses a cost of \$2,000, which is the cost for the most popular gun washers.^{35,36} Based on OAQPS cost factors, taxes and freight were estimated to be equal to eight percent of the equipment cost.³⁹ According to one gun washer manufacturer, the installation cost is equal to 10 percent of the equipment cost.³⁵

Assuming solvent usage is reduced by 80 percent (to 93 lb/yr), the solvent cost would be reduced to \$49/yr. According to gun washer manufacturers, labor requirements to set up and operate the gun washer are about 2 minutes per cleaning cycle (time to allow the guns and other parts to drain are not included).^{35,36} One gun washer manufacturer estimated weekly cleaning of the equipment takes about 10 minutes/wk; it was assumed that this time is sufficient for all maintenance labor requirements.³⁵ Thus, operator labor costs are reduced to

\$200/yr, supervisory labor costs are reduced to \$30/yr, and maintenance labor costs are about \$104/wk.

The amount of spent solvent collected for waste disposal was assumed to be equal to 50 percent of the usage (i.e., 0.5 x 93 lb/yr), and the density was assumed to be 8 lb/gal (a little higher than the density of the virgin solvent). According to the plant, waste disposal costs are \$198/55-gal drum.³⁴

Based on OAQPS cost factors, costs for maintenance materials (i.e., miscellaneous items need to keep the gun washer in working order) were estimated to be equal to the maintenance labor costs; overhead costs were estimated to be equal to 60 percent of all labor and maintenance material costs; and property taxes, insurance, and administrative costs were estimated to be equal to four percent of the TCI.^{38,40} Capital recovery costs were estimated to be equal to 16.275 percent of the TCI, based on an assumed equipment life of 10 years and a marginal rate of return of 10 percent. As shown in Table G-5, the resulting total annual cost is about \$1,250.

2. Comparison of Costs

This analysis shows annual costs for spray gun cleaning at Plant I could be reduced by about 17 percent by installing a gun washer. Assuming emissions are reduced by 90 percent (to be consistent with the above usage and waste assumptions), the cost effectiveness of this control alternative is a savings of about \$2.00/lb of VOC (\$4,000/ton VOC). Plants with a higher cleaning frequency may achieve even greater savings.

B. REFERENCES FOR APPENDIX G

1. Letters and attachments from Kasper, T., Westinghouse Electric Corporation, to Jordan, B. EPA/ESD. February 5 and June 16, 1992. Response to Section 114 information request.
2. Telecon. D. Randall, MRI, with T. Kasper, Westinghouse Electric Corporation. February 5 and March 1, 1993. Spray gun cleaning procedures.

3. U. S. Environmental Protection Agency. Automobile Refinishing Control Techniques Guideline. Research Triangle Park, NC. Draft. September 27, 1991. p. 4-9.
4. Letter and attachments from Muir, G., Graco, Inc., to Randall, D., MRI. February 5, 1993. Cost and operation of gun washers.
5. Letter and attachments from O'Reilly, B., Westinghouse Electric Corporation, to Jordan, B., EPA/ESD. August 15, 1991. Response to Section 114 information request.
6. Letter and attachments from O'Reilly, B., Westinghouse Electric Corporation, to Serageldin, M., EPA/CPB. June 26, 1992. Response to Section 114 information request.
7. Telecon. D. Randall, MRI, with B. O'Reilly, Westinghouse Electric Corporation. March 24, March 26, and April 14, 1993. Spray gun cleaning procedures.
8. Letter and attachments from Self, T., Westinghouse Electric Corporation, to Jordan, B., EPA/ESD. August, 1991. Response to Section 114 information request.
9. Letter and attachments from Self, T., Westinghouse Electric Corporation, to Schmidtke, K., MRI. January 27, 1992. Followup to Section 114 information request.
10. Letter and attachments from Domrese, J., Westinghouse Electric Corporation, to Serageldin, M., EPA/CPB. June 15, 1992. Followup to Section 114 information request.
11. Telecon. D. Randall, MRI, with J. Domrese, Westinghouse Electric Corporation. March 8, 1993. Spray gun cleaning procedures.
12. Letters and attachments from Stephens, R., Square D Company, to Jordan, B., EPA/ESD. July 29, 1991, and January 17, 1992. Response to Section 114 information request.
13. Letter and attachments from Stephens, R., Square D Company, to Wyatt, S., EPA/CPB. June 3, 1992. Followup to Section 114 information request.
14. Telecon. D. Randall, MRI, with R. Stephens, Square D Company. February 19 and April 5, 1993. Spray gun cleaning procedures.
15. Letter and attachments from Robb, R., Herkules Equipment Corporation, to Serageldin, M., EPA/CPB. March 23, 1993. Gun washer design, operation, and costs.

16. Promotional literature from Safety-Kleen Corporation.
17. Letter and attachments from Praschan, E., Motor Vehicle Manufacturers Association to Serageldin, M., EPA/CPB. February 19, 1992. Plant No. 10 response to survey questionnaire.
18. Telecon. D. Randall, MRI, with J. Baguzis, Ford Motor Company. February 16, 1993. Spray gun cleaning procedures with gun washer at MVMA plant No. 10.
19. ENSR Consulting and Engineering. Comparison of Solvent Emissions From Two Types of Spray Gun Cleaning Systems. Prepared for Safety-Kleen Corporation. ENSR Document No. 5831-005-800. March, 1990.
20. Letter from Robb, R., Herkules Equipment Corporation, to South Coast Air Quality Management District. April 25, 1990. Comments on gun washer emission test.
21. Letter and attachments from Herman, K., Steelcase, Inc., to Jordan, B., EPA/ESD. February 4, 1992. Response to Section 114 information request for Chair plant.
22. Letter and attachments from Herman, K., Steelcase, Inc., to Jordan, B., EPA/ESD. April 15, 1992. Response to Section 114 information request for Panel and Systems II plants.
23. Letter and attachments from Herman, K., Steelcase, Inc., to Jordan, B., EPA/ESD. April 1992. Response to Section 114 information request for Systems I plant.
24. Letter and attachments from Herman, K., Steelcase, Inc., to Jordan, B., EPA/ESD. June 25, 1992. Response to Section 114 information request for File plant.
25. Letter and attachments from Herman, K., Steelcase, Inc., to Jordan, B., EPA/ESD. September 18, 1992. Followup response to Section 114 information request for Panel and Systems I plants.
26. Letter and attachments from Herman, K., Steelcase, Inc., to Jordan, B., EPA/ESD. October 5, 1992. Followup response to Section 114 information request for File and Systems II plants.
27. Letter and attachments from Herman, K., Steelcase, Inc., to Jordan, B., EPA/ESD. October 15, 1992. Followup response to Section 114 information request for Chair plant.

28. Telecon. D. Randall, MRI, with K. Herman, Steelcase, Inc. February 1 and 16, 1993. Spray gun cleaning procedures at five Steelcase plants.
29. Reference 18, plant Nos. 2, 3, 4, and 5.
30. Telecon. D. Randall, MRI, with P. Strabbing, Chrysler Corporation. February 23, March 4, and March 22, 1993. Spray gun cleaning procedures at Chrysler plants.
31. Letter and attachments from Praschan, E., American Automobile Manufacturers Association, to Serageldin, M., EPA/CPB. January 13, 1993. Descriptions of automatic line flushing and purging processes.
32. Reference 18, plants 1 and 6.
33. Letters and attachments from Kasper, T., Westinghouse Electric Corporation, to Jordan, B., EPA/ESD. February 5 and June 16, 1992. Response to Section 114 information request.
34. Telecon. D. Randall, MRI, with T. Kasper, Westinghouse Electric Corporation. February 5 and March 1, 1993. Spray gun cleaning procedures.
35. Letter and attachments from Muir, G., Graco, Inc., to Randall, D., MRI. February 5, 1993. Cost and operation of gun washers.
36. Letter and attachments from Robb, R., Herkules Equipment Corporation, to Serageldin, M. EPA/CPB. March 23, 1993. Gun washer design, operation, and costs.
37. Office of Air Quality Planning and Standards Control Cost Manual (4th ed.). U. S. Environmental Protection Agency. Research Triangle Park, NC. Publication No. EPA 450/3-90-006. January 1990.
38. Reference 1. p. 2-29.
39. Reference 1. p. 2-22.
40. Reference 1. p. 2-26.

APPENDIX H.

SPRAY GUN CLEANING PROCEDURES AND
MATERIAL BALANCE CALCULATIONS FOR THE "PAINT
SPRAY GUN" UOS AT CASE STUDY PLANT L

APPENDIX H.

SPRAY GUN CLEANING PROCEDURES AND MATERIAL BALANCE CALCULATIONS FOR THE "PAINT SPRAY GUN" UOS AT CASE STUDY PLANT L

This Appendix describes the spray gun cleaning procedures at case study plant L and presents calculations used for completing the material balance for the "paint spray gun" UOS at this plant. The completed UOS diagram is shown in Figure H-1.

H.1 CLEANING PROCEDURES

Plant L has two hand-held, pressure-feed paint spray guns that are purged with xylene. The plant estimated each gun, and an attached 107-ft paint line, is purged 398 times per year, for a total of 796 cleaning cycles per year. To purge a gun and attached paint line, an unspecified amount of xylene is hand pumped into a 5-gallon pail. The end of the paint line is put in the pail, and solvent is pumped through the hose and gun. Paint is not drained from the system before purging with solvent. Instead, discharge from the gun is first directed into a paint can. When the xylene starts to come through, the painter redirects the discharge to a waste pail. The waste pail is later emptied into a 55-gallon waste drum. The exterior of the lines do not need cleaning. The exterior of the guns may be cleaned occasionally, but the procedure was not reported.

H.2 MATERIAL BALANCE CALCULATIONS FOR SPRAY GUN UOS

As described in Appendix G, the material balance for the UOS at this plant is:

$$V_o = V_1 + \dots + V_8 = S_1 - (W)x(X_w) \quad (1)$$

where:

V_o = total VOC emissions, lb/yr

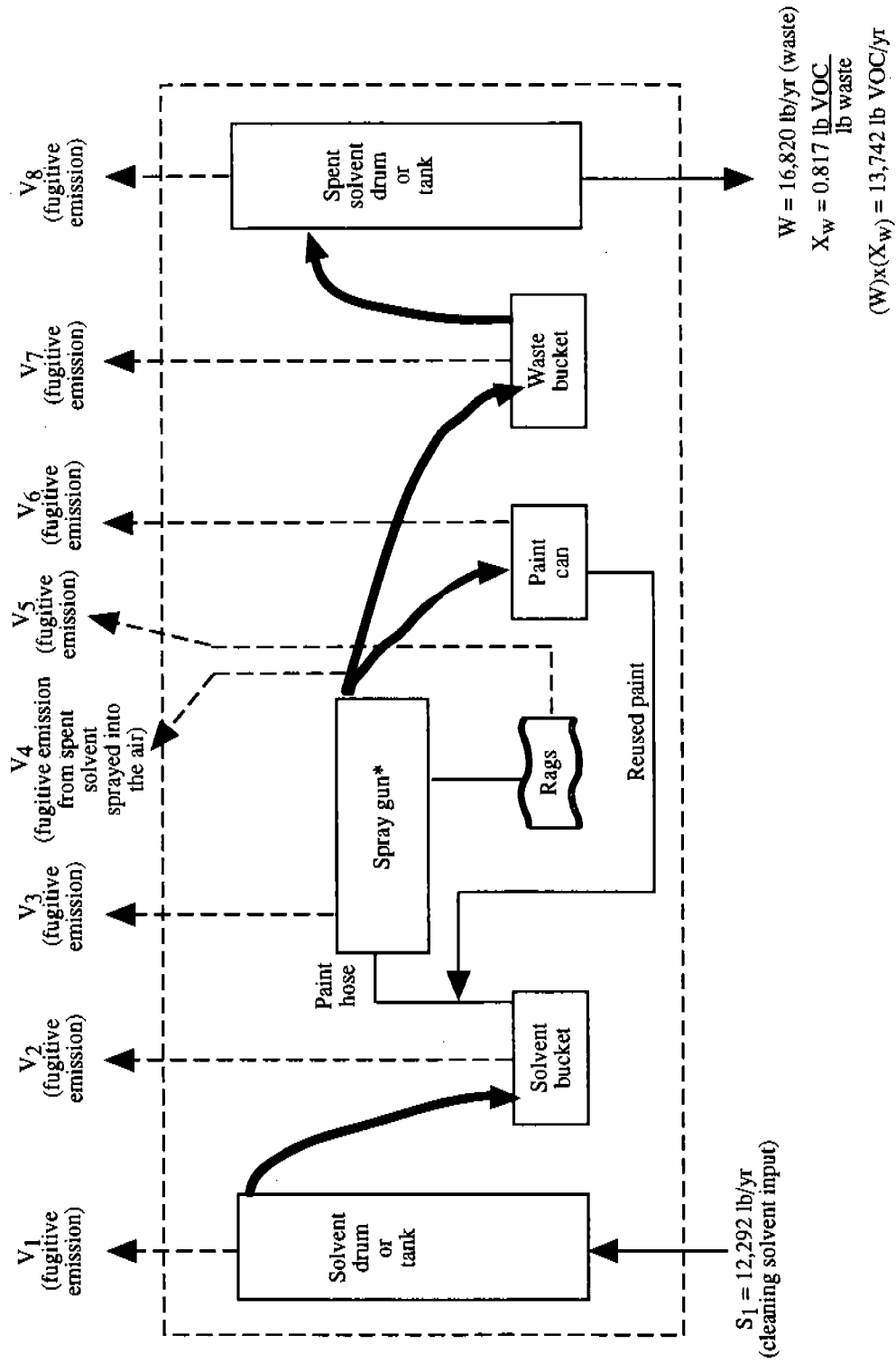

*Note: Up to 4,784 lb VOC/yr of paint solvent are collected in the cleaning solvent waste.

Figure H-1. Schematic of spray gun cleaning unit operation system for case study Plant L.

$V_1 \dots V_8$ = emissions from individual activities within the UOS, lb/yr

S_1 = total weight of solvent usage, lb/yr

W = total weight of waste solvent, lb/yr

X_w = VOC weight fraction of waste solvent, lb VOC/lb waste

For this plant, the calculation is complicated by the fact that the cleaning solvent (xylene) used in the spray gun UOS is also used in several other UOS's, but only the total usage was recorded. Because approximately 97 percent of the xylene was used in the "paint spray gun" UOS and an "epoxy spray gun" UOS, this analysis assumes all of the xylene was used in these two UOS's. Another complicating factor is that a portion of the solvent in the waste came from residual paint in the spray gun that was carried off with the cleaning solvent (this is referred to as "paint solvent" in the rest of this Appendix). Thus, to calculate the cleaning solvent emissions from the spray gun UOS, the emissions calculated by Equation 1 must be increased by the amount of collected paint solvent in the waste container.

For this plant, however, the amount of collected paint solvent is unknown. The plant recorded both W and x_w , but the composition of the waste solvent was not determined. In the absence of this information, it is assumed that the paint solvent volatility is similar to that of xylene (the cleaning solvent). Thus, equal proportions of both solvents are assumed to evaporate.

Adding the paint solvent originally associated with the nonvolatiles (i.e., paint solids) in the waste as an input allows Equation 1 to be used to calculate the total cleaning and paint solvent emissions. (The associated paint solvent is referred to as the "paint solvent input" in the rest of this appendix.) The cleaning solvent emissions are calculated by multiplying the ratio of cleaning solvent input to total solvent input (cleaning plus paint solvent) by the total emissions. Procedures for calculating these values are described below.

H.2.1 Estimation of Paint Solvent Input

The paint solvent input is calculated using the following equation that was also presented in Appendix G:

$$P = (W) \times (1 - X_w) \times (R_p) \times (1 + R_T/X_p) \quad (2)$$

where:

- P = weight of paint solvent associated with the nonvolatile matter in the waste, lb VOC/yr
- W = total weight of waste solvent, lb/yr
- X_w = VOC weight fraction of waste solvent, lb VOC/lb waste
- R_p = ratio of VOC to nonvolatile matter in the purchased paint, lb VOC/lb nonvolatile matter
- R_T = ratio of thinning VOC solvent to paint matter, lb thinning VOC/lb paint
- X_p = fraction of VOC in purchased paint, lb VOC/lb paint
- R_T/X_p = lb thinning VOC/lb paint VOC

According to plant records, waste shipments from the paint spray gun UOS in 1991 were:

$$W = 16,820 \text{ lb waste/yr}$$

Analysis of the contents of two waste drums showed the average VOC content was:

$$X_w = 0.817 \text{ lb VOC/lb waste}$$

The MSDS for the most commonly used paint at Plant L showed the VOC content was between 50 and 70 percent. The nonvolatile matter content, therefore, was between 50 and 30 percent. This is the only paint for which data were available. Thus, X_p was assumed to equal 0.6 for all paint used at the plant, and R_p was assumed to equal 1.5 (i.e., $0.6/0.4 = 1.5$).

Plant records also showed about 1 gal of xylene per week (378 lb/yr) was added to thin 17,415 lb of paint used during the year. Thus, R_T equals 0.0217 for the paint spray gun UOS.

Substituting these data into Equation 2 results in the following estimate of the amount of paint solvent originally associated with the nonvolatiles collected in the paint spray gun UOS waste:

$$\begin{aligned} P_P &= (16,820) \times (1-0.817) \times (1.5) \times (1 + 0.0217/0.6) \\ &= 4,784 \text{ lb VOC/yr} \end{aligned}$$

Equation 2 is used to estimate the paint solvent input for the epoxy spray gun UOS. According to plant records, waste shipments from the epoxy spray gun UOS in 1991 were:

$$W = 7,915 \text{ lb waste/yr}$$

Analysis of the waste showed the VOC content was:

$$X_W = 0.814 \text{ lb VOC/lb waste}$$

No data were available for epoxies. Thus, X_P , R_P , and R_T were assumed to be the same as those noted above for the paints. Substituting these data into Equation 2 results in the following estimate of the solvent originally associated with the epoxy nonvolatiles collected in the epoxy spray gun UOS waste:

$$\begin{aligned} P_E &= (7,915) \times (1-0.814) \times (1.5) \times (1 + 0.0217/0.6) \\ &= 2,288 \text{ lb VOC/yr} \end{aligned}$$

H.2.2 Estimation of Cleaning Solvent Usage

Purchasing and inventory records show the plant used 2,475 gal of xylene (VOC content of 7.27 lb/gal) in the paint and epoxy spray gun UOS's. To determine the amount used in the paint spray gun UOS, it was assumed that the ratio of usage in the two UOS's was equal to the ratio of paint solvent inputs for these UOS's. Thus, the fraction of cleaning solvent used in the paint spray gun UOS is:

$$\begin{aligned} f &= \frac{4,784}{4,784 + 2,288} \\ &= 0.6765 \end{aligned}$$

Therefore, the cleaning solvent usage in the paint spray gun UOS is:

$$\begin{aligned} S_P &= 0.6765 \times 2,475 \text{ gal/yr} \times 7.27 \text{ lb/gal} \\ &= 12,172 \text{ lb solvent/yr} \end{aligned}$$

And, the amount of cleaning solvent used in the epoxy spray gun UOS is:

$$\begin{aligned} S_E &= (1 - 0.6765) \times 2,475 \text{ gal/yr} \times 7.27 \text{ lb/gal} \\ &= 5,821 \text{ lb solvent/yr} \end{aligned}$$

H.2.3 Estimation of Cleaning Solvent Emissions

The total solvent input (cleaning and paint solvents) is given by:

$$S_I = S_p + S_E + P_p + P_E \quad (3)$$

where:

S_I = total solvent input to both the paint spray gun and epoxy spray gun UOS's, lb solvent/yr

Substituting values for the variables in Equation 3 yields:

$$\begin{aligned} S_I &= 12,172 + 5,821 + 4,784 + 2,288 \\ &= 25,065 \text{ lb solvent/yr} \end{aligned}$$

The total solvent in the waste collected from both UOS's is given by:

$$\begin{aligned} W_O &= W_p \times X_{wp} + W_E \times X_{WE} \\ &= (16,820) \times (0.817) + (7,915) \times (0.814) \\ &= 20,185 \text{ lb solvent/yr} \end{aligned}$$

Using the material balance in Equation 1 over both UOS's results in the following total emissions:

$$\begin{aligned} V_O &= 25,065 - 20,185 \\ &= 4,880 \text{ lb solvent/yr} \end{aligned}$$

The assumptions that the volatilities of the cleaning solvent and the paint solvents in both UOS's are comparable, and thus equal portions of each solvent evaporate, are used to calculate the amount of cleaning solvent that evaporates in the spray gun UOS (V_C) as follows:

$$\begin{aligned} V_C &= (V_O) \times (S_p/S_I) \\ &= (4,880) \times (12,172/25,065) \\ &= 2,370 \text{ lb VOC evaporated/yr} \end{aligned}$$

TECHNICAL REPORT DATA
 (Please read Instructions on the reverse before completing)

1. REPORT NO. EPA-453/R-94-015		2.	3. RECIPIENT'S ACCESSION NO.	
4. TITLE AND SUBTITLE Alternative Control Techniques Document - Industrial Cleaning Solvents			5. REPORT DATE February 1994	
			6. PERFORMING ORGANIZATION CODE	
7. AUTHOR(S)			8. PERFORMING ORGANIZATION REPORT NO.	
9. PERFORMING ORGANIZATION NAME AND ADDRESS Midwest Research Institute 401 Harrison Oaks Boulevard, Suite 350 Cary, North Carolina 27513			10. PROGRAM ELEMENT NO.	
			11. CONTRACT/GRANT NO. 68-D1-0115	
12. SPONSORING AGENCY NAME AND ADDRESS U.S. Environmental Protection Agency Emission Standards Division Office of Air Quality Planning and Standards Research Triangle Park, NC 27711			13. TYPE OF REPORT AND PERIOD COVERED Final	
			14. SPONSORING AGENCY CODE	

15. SUPPLEMENTARY NOTES
 EPA Work Assignment Manager: Mohamed Serageldin

16. ABSTRACT

The use of cleaning solvents in industry is a large source of volatile organic compound (VOC) emissions. The study was conducted to identify emission reduction and control techniques that have general application across all industry. The initial approach, which focused on how the cleaning was accomplished, was unsuccessful. The requisite data for such detailed evaluation was unavailable. A second strategy, which focused on the parts and processes being cleaned, produced more meaningful data.

The study's conclusions were that most industries must first quantify how much and where solvents are used for cleaning. With that information, management is then positioned to influence improvements. The report recommends that companies establish a formal accounting system that quantitatively traces where they use cleaning solvents. It also provides suggestions for action by management (or State agencies) to use the resulting information to effect reductions.

17. KEY WORDS AND DOCUMENT ANALYSIS

a. DESCRIPTORS	b. IDENTIFIERS/OPEN ENDED TERMS	c. COSATI Field/Group
Cleaning Solvents Volatile Organic Compound Emissions VOC's	Cleaning Solvents Solvent Accounting and Management Pollution Prevention VOC's	
18. DISTRIBUTION STATEMENT	19. SECURITY CLASS (This Report) Unclassified	21. NO. OF PAGES
	20. SECURITY CLASS (This page) Unclassified	22. PRICE

This page intentionally left blank.

This page intentionally left blank

Appendix B

Summary of Regulations in California Reviewed for Industrial Cleaning Solvents CTG

Appendix B. Summary of Regulations in California Reviewed for Industrial Solvent Cleaning CTG

Regulation	Exemptions	Standards
<p>BAAQMD Regulation 8, Rule 16</p>	<ul style="list-style-type: none"> •1 Semiconductor Solvent Cleaners •2 Aerospace Stripping Operations •3 Vapor Phase Solder Reflow Operations •4 Dry Cleaning Operations •5 Stripping Operations •6 Aerospace components •7 Electrical and electronic components •8 Precision optics •9 Medical devices •10 Cleaning of resin, coating, ink, and adhesive mixing, molding and application equipment •11 Cleaning associated with research and development operations. •12 Performance testing to determine coating, adhesive or ink performance •13 Testing for QA/QC purposes 	<ul style="list-style-type: none"> •14 Work practices to minimize emissions, and •15 Use solvent with VOC content of 50 g/l or less, or •16 Vent emissions to an emission control device achieving 90% reduction
<p>SMAQMD Rule 466</p>	<ul style="list-style-type: none"> •1 Cleaning of solar cells, laser hardware, scientific instruments, and high precision optics, •2 Cleaning of cotton swabs to remove cottonseed oil before cleaning of high precision optics •3 Cleaning of paper-based gaskets and clutch assemblies where rubber is bonded to metal by means of an adhesive •4 Cleaning of application 	<ul style="list-style-type: none"> •17 Work practices to minimize emissions, and •18 Vent emissions to an emission control device achieving 95% reduction through a collection system with a collection efficiency of 90%, or •19 Use solvent with VOC content of 50 g/l or less, except for the following activities: <ul style="list-style-type: none"> ○ 500 g/l for product cleaning during

	<p>equipment used to apply coatings on satellites and radiation effect coatings,</p> <ul style="list-style-type: none"> •5 Cleaning of electrostatic coating application equipment •6 Janitorial cleaning •7 Cleaning of sterilization ink indicating equipment if solvent usage is less than 1.5 gpd. •8 Cleaning with aerosol provided that 160 fluid oz or less of aerosol is used per day 	<p>manufacture of electrical apparatus components and electronic components</p> <ul style="list-style-type: none"> ○ 800 g/l for product cleaning during manufacture of medical devices and pharmaceuticals, platelets, ○ 900 g/l for repair and maintenance of electrical apparatus components and electrical components ○ 800 g/l for repair and maintenance of medical devices and pharmaceuticals tools, equipment, and machinery, and platelets ○ 600 g/l for repair and maintenance of medical devices and pharmaceuticals general work surfaces ○ 300 g/l for solvent based architectural coating application equipment
<p>SCAQMD Rule 1171</p>	<ul style="list-style-type: none"> •1 Cleaning carried out in batch loaded cold cleaners, vapor degreasers, conveyerized degreasers, •2 Motion picture film cleaning equipment •3 Dry cleaning subject to Rule 1102 or 1422 •4 Semiconductor manufacturing subject to Rule 1164 	<ul style="list-style-type: none"> •21 Work practices to minimize emissions, and •22 Vent emissions to an emission control device achieving 95% reduction through a collection system with a collection efficiency of 90%, or •23 Use solvent with VOC content of 25 g/l or less, except for the following

	<ul style="list-style-type: none"> •5 Aerospace assembly and component manufacturing operations (except coating application equipment cleaning, and storage and disposal of VOC containing materials used in solvent cleaning operations) subject to Rule 1124 •6 Resin manufacturing subject to Rule 1141 •7 Coatings and ink manufacturing subject to Rule 1141.1 •8 Janitorial cleaning •9 Stripping of cured coatings, cured ink, or cured adhesives <p>The following do not have to comply with VOC content limits in the rule:</p> <ul style="list-style-type: none"> •10 Cleaning solar cells, laser hardware, scientific instruments, and high precision optics •11 Medical and pharmaceutical facilities using up to 1.5 gpd solvents •12 Cleaning motor vehicles on application lines subject to Rule 1115 •13 Cleaning of photocurable resins from stereolithography equipment and models •14 Cleaning of adhesive application equipment for thin metal laminating if VOC content is no more than 950 g/L •15 Cleaning of electronic cables if VOC content is no more than 400 g/l •16 Circuit board touch up if 	<p>activities:</p> <ul style="list-style-type: none"> ○ 100 g/l for product cleaning during manufacture of electrical apparatus components and electronic components ○ 800 g/l for product cleaning during manufacture of medical devices and pharmaceuticals, ○ 100 g/l for repair and maintenance of electrical apparatus components and electrical components ○ 800 g/l for repair and maintenance of medical devices and pharmaceuticals tools, equipment, and machinery, ○ 600 g/l for repair and maintenance of medical devices and pharmaceuticals general work surfaces ○ 100 g/l for gravure printing on publications ○ 100 g/l for lithographic or letterpress printing (roller wash-step 1, and step 2) ○ 100 g/l for screen printing ○ 100 g/l for ultraviolet ink/electron beam ink application equipment
--	---	---

	<p>VOC content is nor more than 800 g/l</p> <ul style="list-style-type: none">•17Transdermal drug delivery product manufacturing using less than 3 gpd ethyl acetate•18Cleaning of application equipment used for solvent-borne fluopolymer coatings if VOC content is no more than 900 g/l•19Facilities cleaning sterilization indicating ink using less than 1.5 gpd solvent•20Cleaning operations in printing pre-press or graphic arts pre-press areas, including the cleaning of film processors, color scanners, plate processors, film cleaning, and plate cleaning•9 Cleaning of cotton swabs to remove cottonseed oil before cleaning of high precision optics•10Cleaning of paper-based gaskets and clutch assemblies where rubber is bonded to metal by means of an adhesive•11Cleaning of application equipment used to apply coatings on satellites and radiation effect coatings,•21Cleaning with aerosol provided that 160 fluid oz or less of aerosol is used per day•20Cleaning associated with research and development operations.•22Testing for QA/QC	<ul style="list-style-type: none">○ 100 g/l specialty flexographic printing
--	--	---

	purposes	
--	----------	--

This page intentionally left blank

This page intentionally left blank

Appendix C

Summary of NAICS Codes for nonattainment facilities Estimated to meet the applicability criteria recommended in this CTG

This page intentionally left blank

This page intentionally left blank

Appendix C: Summary of NAICS Codes for nonattainment estimated to meet the applicability criteria recommended in the CTG

NAICS	NAICS DESCRIPTION
42	Wholesale Trade
321	Wood Product Manufacturing
325	Chemical Manufacturing
327	Nonmetallic Mineral Product Manufacturing
331	Primary Metal Manufacturing
332	Fabricated Metal Product Manufacturing
333	Machinery Manufacturing
334	Computer and Electronic Product Manufacturing
337	Furniture and Related Product Manufacturing
339	Miscellaneous Manufacturing
3336	Engine, Turbine, and Power Transmission Equipment Manufacturing
3399	Other Miscellaneous Manufacturing
11112	Oilseed (except Soybean) Farming
23511	Plumbing, Heating, and Air-Conditioning Contractors
23521	Painting and Wall Covering Contractors
31212	Breweries
31321	Broadwoven Fabric Mills
31323	Nonwoven Fabric Mills
31331	Textile and Fabric Finishing Mills
31332	Fabric Coating Mills
31611	Leather and Hide Tanning and Finishing
32191	Millwork
32199	All Other Wood Product Manufacturing
32213	Paperboard Mills
32311	Printing
32551	Paint and Coating Manufacturing
32552	Adhesive Manufacturing
32591	Printing Ink Manufacturing
32613	Laminated Plastics Plate, Sheet (except Packaging), and Shape Manufacturing
32614	Polystyrene Foam Product Manufacturing
32615	Urethane and Other Foam Product (except Polystyrene) Manufacturing
32721	Glass and Glass Product Manufacturing
32739	Other Concrete Product Manufacturing
32791	Abrasive Product Manufacturing
33121	Iron and Steel Pipe and Tube Manufacturing from Purchased

	Steel
33231	Plate Work and Fabricated Structural Product Manufacturing
33251	Hardware Manufacturing
33281	Coating, Engraving, Heat Treating, and Allied Activities
33291	Metal Valve Manufacturing
33299	All Other Fabricated Metal Product Manufacturing
33312	Construction Machinery Manufacturing
33322	Plastics and Rubber Industry Machinery Manufacturing
33329	Other Industrial Machinery Manufacturing
33341	Ventilation, Heating, Air-Conditioning, and Commercial Refrigeration Equipment Manufacturing
33392	Material Handling Equipment Manufacturing
33511	Electric Lamp Bulb and Part Manufacturing
33611	Automobile and Light Duty Motor Vehicle Manufacturing
33612	Heavy Duty Truck Manufacturing
33621	Motor Vehicle Body and Trailer Manufacturing
33632	Motor Vehicle Electrical and Electronic Equipment Manufacturing
33634	Motor Vehicle Brake System Manufacturing
33635	Motor Vehicle Transmission and Power Train Parts Manufacturing
33636	Motor Vehicle Seating and Interior Trim Manufacturing
33651	Railroad Rolling Stock Manufacturing
33699	Other Transportation Equipment Manufacturing
33711	Wood Kitchen Cabinet and Countertop Manufacturing
33712	Household and Institutional Furniture Manufacturing
33721	Office Furniture (including Fixtures) Manufacturing
33995	Sign Manufacturing
42131	Lumber, Plywood, Millwork, and Wood Panel Wholesalers
42183	Industrial Machinery and Equipment Wholesalers
42213	Industrial and Personal Service Paper Wholesalers
44211	Furniture Stores
45431	Fuel Dealers
48821	Support Activities for Rail Transportation
49211	Couriers
51223	Music Publishers
53112	Lessors of Nonresidential Buildings (except Miniwarehouses)
54138	Testing Laboratories
54171	Research and Development in the Physical, Engineering, and Life Sciences
61131	Colleges, Universities, and Professional Schools
81121	Electronic and Precision Equipment Repair and Maintenance
81131	Commercial and Industrial Machinery and Equipment (except Automotive and Electronic) Repair and Maintenance
81149	Other Personal and Household Goods Repair and Maintenance
92214	Correctional Institutions
92612	Regulation and Administration of Transportation Programs
211111	Crude Petroleum and Natural Gas Extraction

211112	Natural Gas Liquid Extraction
221111	Hydroelectric Power Generation
221112	Fossil Fuel Electric Power Generation
221113	Nuclear Electric Power Generation
221310	Water Supply and Irrigation Systems
236118	Residential Remodelers
236220	Commercial and Institutional Building Construction
237120	Oil and Gas Pipeline and Related Structures Construction
237310	Highway, Street, and Bridge Construction
238170	Siding Contractors
238290	Other Building Equipment Contractors
38320	Painting and Wall Covering Contractors
238350	Finish Carpentry Contractors
238910	Site Preparation Contractors
311111	Dog and Cat Food Manufacturing
311320	Chocolate and Confectionery Manufacturing from Cacao Beans
311340	Nonchocolate Confectionery Manufacturing
311812	Commercial Bakeries
311919	Other Snack Food Manufacturing
311942	Spice and Extract Manufacturing
311991	Perishable Prepared Food Manufacturing
312111	Soft Drink Manufacturing
312112	Bottled Water Manufacturing
312120	Breweries
312221	Cigarette Manufacturing
313112	Yarn Texturizing, Throwing, and Twisting Mills
313113	Thread Mills
313221	Narrow Fabric Mills
313230	Nonwoven Fabric Mills
313311	Broadwoven Fabric Finishing Mills
313312	Textile and Fabric Finishing (except Broadwoven Fabric) Mills
313320	Fabric Coating Mills
314110	Carpet and Rug Mills
314912	Canvas and Related Product Mills
314991	Rope, Cordage, and Twine Mills
314992	Tire Cord and Tire Fabric Mills
314999	All Other Miscellaneous Textile Product Mills
315111	Sheer Hosiery Mills
315991	Hat, Cap, and Millinery Manufacturing
315999	Other Apparel Accessories and Other Apparel Manufacturing
316110	Leather and Hide Tanning and Finishing
316213	Men's Footwear (except Athletic) Manufacturing
316999	All Other Leather Good Manufacturing
321114	Wood Preservation
321219	Reconstituted Wood Product Manufacturing
321911	Wood Window and Door Manufacturing

321918	Other Millwork (including Flooring)
321920	Wood Container and Pallet Manufacturing
321991	Manufactured Home (Mobile Home) Manufacturing
321992	Prefabricated Wood Building Manufacturing
321999	All Other Miscellaneous Wood Product Manufacturing
322110	Pulp Mills
322121	Paper (except Newsprint) Mills
322122	Newsprint Mills
322130	Paperboard Mills
322211	Corrugated and Solid Fiber Box Manufacturing
322212	Folding Paperboard Box Manufacturing
322214	Fiber Can, Tube, Drum, and Similar Products Manufacturing
322221	Coated and Laminated Packaging Paper and Plastics Film Manufacturing
322222	Coated and Laminated Paper Manufacturing
322231	Die-Cut Paper and Paperboard Office Supplies Manufacturing
322232	Envelope Manufacturing
322299	All Other Converted Paper Product Manufacturing
323110	Commercial Lithographic Printing
323111	Commercial Gravure Printing
323112	Commercial Flexographic Printing
323113	Commercial Screen Printing
323116	Manifold Business Forms Printing
323117	Books Printing
323122	Prepress Services
324110	Petroleum Refineries
324122	Asphalt Shingle and Coating Materials Manufacturing
324191	Petroleum Lubricating Oil and Grease Manufacturing
324199	All Other Petroleum and Coal Products Manufacturing
325110	Petrochemical Manufacturing
325131	Inorganic Dye and Pigment Manufacturing
325132	Synthetic Organic Dye and Pigment Manufacturing
325188	All Other Basic Inorganic Chemical Manufacturing
325199	All Other Basic Organic Chemical Manufacturing
325211	Plastics Material and Resin Manufacturing
325212	Synthetic Rubber Manufacturing
325222	Noncellulosic Organic Fiber Manufacturing
325411	Medicinal and Botanical Manufacturing
325412	Pharmaceutical Preparation Manufacturing
325413	In-Vitro Diagnostic Substance Manufacturing
325510	Paint and Coating Manufacturing
325520	Adhesive Manufacturing
325611	Soap and Other Detergent Manufacturing
325612	Polish and Other Sanitation Good Manufacturing
325613	Surface Active Agent Manufacturing
325620	Toilet Preparation Manufacturing
325910	Printing Ink Manufacturing
325991	Custom Compounding of Purchased Resins

325992	Photographic Film, Paper, Plate, and Chemical Manufacturing
325998	All Other Miscellaneous Chemical Product and Preparation Manufacturing
326112	Plastics Packaging Film and Sheet (including Laminated) Manufacturing
326113	Unlaminated Plastics Film and Sheet (except Packaging) Manufacturing
326121	Unlaminated Plastics Profile Shape Manufacturing
326130	Laminated Plastics Plate, Sheet (except Packaging), and Shape Manufacturing
326140	Polystyrene Foam Product Manufacturing
326150	Urethane and Other Foam Product (except Polystyrene) Manufacturing
326160	Plastics Bottle Manufacturing
326191	Plastics Plumbing Fixture Manufacturing
326192	Resilient Floor Covering Manufacturing
326199	All Other Plastics Product Manufacturing
326211	Tire Manufacturing (except Retreading)
326212	Tire Retreading
326220	Rubber and Plastics Hoses and Belting Manufacturing
326291	Rubber Product Manufacturing for Mechanical Use
326299	All Other Rubber Product Manufacturing
327112	Vitreous China, Fine Earthenware, and Other Pottery Product Manufacturing
327121	Brick and Structural Clay Tile Manufacturing
327123	Other Structural Clay Product Manufacturing
327124	Clay Refractory Manufacturing
327125	Nonclay Refractory Manufacturing
327211	Flat Glass Manufacturing
327212	Other Pressed and Blown Glass and Glassware Manufacturing
327213	Glass Container Manufacturing
327215	Glass Product Manufacturing Made of Purchased Glass
327310	Cement Manufacturing
327331	Concrete Block and Brick Manufacturing
327332	Concrete Pipe Manufacturing
327390	Other Concrete Product Manufacturing
327910	Abrasive Product Manufacturing
327991	Cut Stone and Stone Product Manufacturing
327993	Mineral Wool Manufacturing
327999	All Other Miscellaneous Nonmetallic Mineral Product Manufacturing
331111	Iron and Steel Mills
331112	Electrometallurgical Ferroalloy Product Manufacturing
331210	Iron and Steel Pipe and Tube Manufacturing from Purchased Steel
331221	Rolled Steel Shape Manufacturing
331222	Steel Wire Drawing
331312	Primary Aluminum Production
331314	Secondary Smelting and Alloying of Aluminum

331315	Aluminum Sheet, Plate, and Foil Manufacturing
331316	Aluminum Extruded Product Manufacturing
331319	Other Aluminum Rolling and Drawing
331421	Copper Rolling, Drawing, and Extruding
331422	Copper Wire (except Mechanical) Drawing
331423	Secondary Smelting, Refining, and Alloying of Copper
331491	Nonferrous Metal (except Copper and Aluminum) Rolling, Drawing, and Extruding
331511	Iron Foundries
331512	Steel Investment Foundries
331513	Steel Foundries (except Investment)
331524	Aluminum Foundries (except Die-Casting)
331525	Copper Foundries (except Die-Casting)
331528	Other Nonferrous Foundries (except Die-Casting)
332112	Nonferrous Forging
332114	Custom Roll Forming
332115	Crown and Closure Manufacturing
332116	Metal Stamping
332117	Powder Metallurgy Part Manufacturing
332211	Cutlery and Flatware (except Precious) Manufacturing
332212	Hand and Edge Tool Manufacturing
332213	Saw Blade and Handsaw Manufacturing
332214	Kitchen Utensil, Pot, and Pan Manufacturing
332311	Prefabricated Metal Building and Component Manufacturing
332312	Fabricated Structural Metal Manufacturing
332313	Plate Work Manufacturing
332321	Metal Window and Door Manufacturing
332322	Sheet Metal Work Manufacturing
332323	Ornamental and Architectural Metal Work Manufacturing
332410	Power Boiler and Heat Exchanger Manufacturing
332420	Metal Tank (Heavy Gauge) Manufacturing
332431	Metal Can Manufacturing
332439	Other Metal Container Manufacturing
332510	Hardware Manufacturing
332611	Spring (Heavy Gauge) Manufacturing
332612	Spring (Light Gauge) Manufacturing
332618	Other Fabricated Wire Product Manufacturing
332721	Precision Turned Product Manufacturing
332722	Bolt, Nut, Screw, Rivet, and Washer Manufacturing
332811	Metal Heat Treating
332812	Metal Coating, Engraving (except Jewelry and Silverware), and Allied Services to Manufacturers
332813	Electroplating, Plating, Polishing, Anodizing, and Coloring
332911	Industrial Valve Manufacturing
332919	Other Metal Valve and Pipe Fitting Manufacturing
332991	Ball and Roller Bearing Manufacturing
332993	Ammunition (except Small Arms) Manufacturing
332994	Small Arms Manufacturing

332996	Fabricated Pipe and Pipe Fitting Manufacturing
332998	Enameled Iron and Metal Sanitary Ware Manufacturing
332999	All Other Miscellaneous Fabricated Metal Product Manufacturing
333111	Farm Machinery and Equipment Manufacturing
333120	Construction Machinery Manufacturing
333131	Mining Machinery and Equipment Manufacturing
333132	Oil and Gas Field Machinery and Equipment Manufacturing
333210	Sawmill and Woodworking Machinery Manufacturing
333291	Paper Industry Machinery Manufacturing
333292	Textile Machinery Manufacturing
333293	Printing Machinery and Equipment Manufacturing
333295	Semiconductor Machinery Manufacturing
333298	All Other Industrial Machinery Manufacturing
333314	Optical Instrument and Lens Manufacturing
333315	Photographic and Photocopying Equipment Manufacturing
333319	Other Commercial and Service Industry Machinery Manufacturing
333412	Industrial and Commercial Fan and Blower Manufacturing
333414	Heating Equipment (except Warm Air Furnaces) Manufacturing
333415	Air-Conditioning and Warm Air Heating Equipment and Commercial and Industrial Refrigeration Equipment Manufacturing
333512	Machine Tool (Metal Cutting Types) Manufacturing
333515	Cutting Tool and Machine Tool Accessory Manufacturing
333516	Rolling Mill Machinery and Equipment Manufacturing
333611	Turbine and Turbine Generator Set Units Manufacturing
333612	Speed Changer, Industrial High-Speed Drive, and Gear Manufacturing
333613	Mechanical Power Transmission Equipment Manufacturing
333618	Other Engine Equipment Manufacturing
333911	Pump and Pumping Equipment Manufacturing
333912	Air and Gas Compressor Manufacturing
333921	Elevator and Moving Stairway Manufacturing
333922	Conveyor and Conveying Equipment Manufacturing
333923	Overhead Traveling Crane, Hoist, and Monorail System Manufacturing
333924	Industrial Truck, Tractor, Trailer, and Stacker Machinery Manufacturing
333991	Power-Driven Handtool Manufacturing
333994	Industrial Process Furnace and Oven Manufacturing
333999	All Other Miscellaneous General Purpose Machinery Manufacturing
334111	Electronic Computer Manufacturing
334112	Computer Storage Device Manufacturing
334113	Computer Terminal Manufacturing
334119	Other Computer Peripheral Equipment Manufacturing
334220	Radio and Television Broadcasting and Wireless Communications Equipment Manufacturing

334290	Other Communications Equipment Manufacturing
334310	Audio and Video Equipment Manufacturing
334411	Electron Tube Manufacturing
334412	Bare Printed Circuit Board Manufacturing
334413	Semiconductor and Related Device Manufacturing
334414	Electronic Capacitor Manufacturing
334415	Electronic Resistor Manufacturing
334416	Electronic Coil, Transformer, and Other Inductor Manufacturing
334417	Electronic Connector Manufacturing
334418	Printed Circuit Assembly (Electronic Assembly) Manufacturing
334419	Other Electronic Component Manufacturing
334510	Electromedical and Electrotherapeutic Apparatus Manufacturing
334511	Search, Detection, Navigation, Guidance, Aeronautical, and Nautical System and Instrument Manufacturing
334512	Automatic Environmental Control Manufacturing for Residential, Commercial, and Appliance Use
334513	Instruments and Related Products Manufacturing for Measuring, Displaying, and Controlling Industrial Process Variables
334516	Analytical Laboratory Instrument Manufacturing
334517	Irradiation Apparatus Manufacturing
334518	Watch, Clock, and Part Manufacturing
334519	Other Measuring and Controlling Device Manufacturing
334613	Magnetic and Optical Recording Media Manufacturing
335110	Electric Lamp Bulb and Part Manufacturing
335121	Residential Electric Lighting Fixture Manufacturing
335122	Commercial, Industrial, and Institutional Electric Lighting Fixture Manufacturing
335129	Other Lighting Equipment Manufacturing
335211	Electric Housewares and Household Fan Manufacturing
335221	Household Cooking Appliance Manufacturing
335222	Household Refrigerator and Home Freezer Manufacturing
335228	Other Major Household Appliance Manufacturing
335311	Power, Distribution, and Specialty Transformer Manufacturing
335312	Motor and Generator Manufacturing
335313	Switchgear and Switchboard Apparatus Manufacturing
335314	Relay and Industrial Control Manufacturing
335911	Storage Battery Manufacturing
335921	Fiber Optic Cable Manufacturing
335929	Other Communication and Energy Wire Manufacturing
335932	Noncurrent-Carrying Wiring Device Manufacturing
335999	All Other Miscellaneous Electrical Equipment and Component Manufacturing
336111	Automobile Manufacturing
336112	Light Truck and Utility Vehicle Manufacturing

336211	Motor Vehicle Body Manufacturing
336212	Truck Trailer Manufacturing
336213	Motor Home Manufacturing
336214	Travel Trailer and Camper Manufacturing
336311	Carburetor, Piston, Piston Ring, and Valve Manufacturing
336312	Gasoline Engine and Engine Parts Manufacturing
336321	Vehicular Lighting Equipment Manufacturing
336322	Other Motor Vehicle Electrical and Electronic Equipment Manufacturing
336340	Motor Vehicle Brake System Manufacturing
336350	Motor Vehicle Transmission and Power Train Parts Manufacturing
336360	Motor Vehicle Seating and Interior Trim Manufacturing
336370	Motor Vehicle Metal Stamping
336399	All Other Motor Vehicle Parts Manufacturing
336412	Aircraft Engine and Engine Parts Manufacturing
336413	Other Aircraft Parts and Auxiliary Equipment Manufacturing
336414	Guided Missile and Space Vehicle Manufacturing
336510	Railroad Rolling Stock Manufacturing
336611	Ship Building and Repairing
336612	Boat Building
336999	All Other Transportation Equipment Manufacturing
337110	Wood Kitchen Cabinet and Countertop Manufacturing
337121	Upholstered Household Furniture Manufacturing
337122	Nonupholstered Wood Household Furniture Manufacturing
337124	Metal Household Furniture Manufacturing
337125	Household Furniture (except Wood and Metal) Manufacturing
337127	Institutional Furniture Manufacturing
337129	Wood Television, Radio, and Sewing Machine Cabinet Manufacturing
337211	Wood Office Furniture Manufacturing
337212	Custom Architectural Woodwork and Millwork Manufacturing
337214	Office Furniture (except Wood) Manufacturing
337215	Showcase, Partition, Shelving, and Locker Manufacturing
337920	Blind and Shade Manufacturing
339111	Laboratory Apparatus and Furniture Manufacturing
339112	Surgical and Medical Instrument Manufacturing
339113	Surgical Appliance and Supplies Manufacturing
339115	Ophthalmic Goods Manufacturing
339911	Jewelry (except Costume) Manufacturing
339912	Silverware and Hollowware Manufacturing
339914	Costume Jewelry and Novelty Manufacturing
339920	Sporting and Athletic Goods Manufacturing
339932	Game, Toy, and Children's Vehicle Manufacturing
339941	Pen and Mechanical Pencil Manufacturing
339942	Lead Pencil and Art Good Manufacturing
339950	Sign Manufacturing

339991	Gasket, Packing, and Sealing Device Manufacturing
339992	Musical Instrument Manufacturing
339993	Fastener, Button, Needle, and Pin Manufacturing
339995	Burial Casket Manufacturing
339999	All Other Miscellaneous Manufacturing
423110	Automobile and Other Motor Vehicle Merchant Wholesalers
423310	Lumber, Plywood, Millwork, and Wood Panel Merchant Wholesalers
423510	Metal Service Centers and Other Metal Merchant Wholesalers
423810	Construction and Mining (except Oil Well) Machinery and Equipment Merchant Wholesalers
423990	Other Miscellaneous Durable Goods Merchant Wholesalers
424690	Other Chemical and Allied Products Merchant Wholesalers
424950	Paint, Varnish, and Supplies Merchant Wholesalers
425110	Business to Business Electronic Markets
425120	Wholesale Trade Agents and Brokers
441110	New Car Dealers
441120	Used Car Dealers
442110	Furniture Stores
442210	Floor Covering Stores
443111	Household Appliance Stores
444120	Paint and Wallpaper Stores
444190	Other Building Material Dealers
446199	All Other Health and Personal Care Stores
451110	Sporting Goods Stores
453998	All Other Miscellaneous Store Retailers (except Tobacco Stores)
454312	Liquefied Petroleum Gas (Bottled Gas) Dealers
481219	Other Nonscheduled Air Transportation
482111	Line-Haul Railroads
485111	Mixed Mode Transit Systems
485113	Bus and Other Motor Vehicle Transit Systems
485410	School and Employee Bus Transportation
485999	All Other Transit and Ground Passenger Transportation
488190	Other Support Activities for Air Transportation
488210	Support Activities for Rail Transportation
488490	Other Support Activities for Road Transportation
488999	All Other Support Activities for Transportation
491110	Postal Service
493110	General Warehousing and Storage
511110	Newspaper Publishers
511120	Periodical Publishers
512110	Motion Picture and Video Production
512220	Integrated Record Production/Distribution
515120	Television Broadcasting
523930	Investment Advice
531120	Lessors of Nonresidential Buildings (except Miniwarehouses)
532299	All Other Consumer Goods Rental

532411	Commercial Air, Rail, and Water Transportation Equipment Rental and Leasing
541330	Engineering Services
541360	Geophysical Surveying and Mapping Services
541380	Testing Laboratories
541710	Research and Development in the Physical, Engineering, and Life Sciences
541720	Research and Development in the Social Sciences and Humanities
541850	Display Advertising
541940	Veterinary Services
561499	All Other Business Support Services
562212	Solid Waste Landfill
562910	Remediation Services
562998	All Other Miscellaneous Waste Management Services
611110	Elementary and Secondary Schools
611210	Junior Colleges
611310	Colleges, Universities, and Professional Schools
611513	Apprenticeship Training
621511	Medical Laboratories
621512	Diagnostic Imaging Centers
622110	General Medical and Surgical Hospitals
622210	Psychiatric and Substance Abuse Hospitals
622310	Specialty (except Psychiatric and Substance Abuse) Hospitals
711310	Promoters of Performing Arts, Sports, and Similar Events with Facilities
711510	Independent Artists, Writers, and Performers
713110	Amusement and Theme Parks
722310	Food Service Contractors
811111	General Automotive Repair
811118	Other Automotive Mechanical and Electrical Repair and Maintenance
811121	Automotive Body, Paint, and Interior Repair and Maintenance
811122	Automotive Glass Replacement Shops
811211	Consumer Electronics Repair and Maintenance
811310	Commercial and Industrial Machinery and Equipment (except Automotive and Electronic) Repair and Maintenance
811412	Appliance Repair and Maintenance
811420	Reupholstery and Furniture Repair
811490	Other Personal and Household Goods Repair and Maintenance
812320	Drycleaning and Laundry Services (except Coin-Operated)
812921	Photofinishing Laboratories (except One-Hour)
812922	One-Hour Photofinishing
812990	All Other Personal Services
921190	Other General Government Support
922140	Correctional Institutions
923130	Administration of Human Resource Programs (except Education, Public Health, and Veterans' Affairs Programs)

923140	Administration of Veterans' Affairs
926120	Regulation and Administration of Transportation Programs
927110	Space Research and Technology

This page intentionally left blank

Appendix D

Number of Nonattainment Facilities organized by State that are
Estimated to Meet the Applicability Criteria Recommended in the
CTG,

This page intentionally left blank.

Appendix D. Number of nonattainment facilities organized by State that are estimated to meet the applicability criteria recommended in the CTG

State	Number of Facilities	Baseline VOC Emissions from Solvent Utilization (Mg/yr)
Alabama	17	665
Arkansas	1	23
Arizona	51	1,567
California	619	5,730
Colorado	203	2,191
Connecticut	21	349
Delaware	3	18
Georgia	9	639
Illinois	130	2,293
Indiana	162	5,825
Kentucky	23	1,329
Louisiana	5	111
Massachusetts	268	2,960
Maryland	19	442
Maine	4	24
Michigan	157	3,469
Missouri	60	1,583
North Carolina	154	12,013
New Hampshire	11	447
New Jersey	32	657
New York	11	381
Ohio	17	1,823
Pennsylvania	166	3,660
Rhode Island	27	465
South Carolina	36	2,538
Tennessee	82	4,307
Texas	92	2,558
Virginia	36	2,762
Wisconsin	97	1,625
West Virginia	11	807
Totals:	2,524	63,261

This page intentionally left blank

Appendix E

Costs and Emission Reductions for the Recommendations Concerning Solvent Substitution

Appendix E

Costs and Emission Reductions for the Recommendation Concerning Solvent Substitution

I. Introduction

This memorandum addresses how we calculated the costs and VOC emission reductions for the recommended option involving substituting a high VOC solvent with a cleaning solution with 50gram per liter VOC.

According to the 2002 National Emissions Inventory (NEI), there are 2,524 facilities conducting solvent cleaning operations in the United States that are located in ozone nonattainment areas (based on April 2004 designations). These facilities had emissions that exceed the emission threshold of 6.8 kg (15 lb) of VOC per day before control. Total aggregate VOC emissions from solvent cleaning operations from these nonattainment sources are approximately 64,000 Mg/yr (71,000 tpy). We identified the facilities above the recommended daily VOC emission limit threshold from all SCC codes at the facility with source category classifications of interest.

The total VOC emissions from solvent cleaning operations were first determined by identifying SCCs that corresponded to solvent evaporation or solvent utilization at a facility. In this analysis, the SCCs that fit this category included SCC codes with an SCC level 1 description of "Petroleum and Solvent Evaporation" or "Solvent Utilization." Next, this list of applicable SCC codes was narrowed to codes where the SCC level 2 code included "surface coating", "degreasing", "dry cleaning", "graphic arts", "rubber/plastics", "All Solvent User Categories", or "organic solvent evaporation" it was included in the population of total VOC emissions from solvent cleaning operations.

This list of applicable SCC codes was further divided into one of three general groups: halogenated solvents, parts cleaners, and other solvent cleaning operations. Halogenated solvents were identified by reviewing the name of the solvent listed in the SCC level 4 description for halogenated compounds. As a result, all SCC codes representing halogenated solvents were removed from our estimate of total VOC emissions from solvent cleaning operations. SCC codes with "degreasing" or "cold solvent cleaning/stripping" in the SCC level 3 description were identified as parts cleaners. The final subgroup covers "other solvent cleaning operations," and this group includes all of the applicable SCC codes that were not classified as halogenated solvents or parts cleaners.

Several industries with solvent cleaning operations are covered under either section 183(e) of the Clean Air Act or are part of a category with a specific exemption to

a Bay Area Rule. These are listed in the CTG, and were removed from the total VOC calculation.

This list of applicable SCC codes was further divided into one of three general groups: halogenated solvents, parts cleaners, and other solvent cleaning operations. Halogenated solvents were identified by reviewing the name of the solvent listed in the SCC level 4 description for halogenated compounds. As a result, all SCC codes representing halogenated solvents were removed from our estimate of total VOC emissions from solvent cleaning operations. SCC codes with “degreasing” or “cold solvent cleaning/stripping” in the SCC level 3 description were classified as part cleaners. The final subgroup covers “other solvent cleaning operations,” and this group includes all of the applicable SCC codes that were not classified as halogenated solvents or parts cleaners.

As a result of this analysis, we determined that there were approximately 64,000 Mg/yr (71,000 tpy) VOC from solvent cleaning operations. Of this total, 4,000 Mg/yr (4,400 tpy) were identified as parts cleaners and the remaining 60,000 Mg/yr (66,000 tpy) were classified as other solvent cleaning operations. We did not include in this analysis cleaning solvent emissions from 183(e) category of sources. Nor did we include emissions from research and development facilities, or emissions from manufacturing and assembly of electrical and electronic components.

II. Cost Analysis

For this analysis, it was assumed that the total VOC emitted is equal to the total VOC used for solvent cleaning. This value was converted to a volume by using an average specific gravity (900g/l) for a typical all VOC cleaning solvents found in the ACT.

The study provided by the California Bay Area AQMD shows that the cost-effectiveness for meeting the 50 grams of VOC per liter of cleaning material limit for a parts cleaner is estimated at \$1,832/Mg (1,664/ton).^{1,2} This represents the annual cost of compliance (industry wide) for parts cleaners (Table 4 of the Bay Area Regulation 8, Rule 16). We determined that replacing high VOC content cleaning materials with low VOC water-based cleaning materials for the other cleaning (unit) operations (e.g., cleaning of large manufactured surfaces, tank cleaning, and gun cleaning, etc.) would result in an estimated cost savings of \$1,460/Mg. For this calculation we only considered the cost-difference in cleaning material cost and cost-difference in waste disposal cost. The savings is a result of lower cost of aqueous cleaners which offset the increase in waste disposal cost for aqueous cleaners. .¹

Therefore, the national annual costs for complying with the 50 grams of VOC per liter limit on a cleaning (unit) operation basis are a summation of the costs of operating parts cleaners, and the savings realized by the other solvent cleaning operations. The annual national cost and emission impacts are a cost savings of \$76 million and 61,000 Mg/yr (67,000 tpy) reduction in VOC emissions. Table 2 summarizes the cost estimates

by attainment classification. Attachment 1 presents a sample calculation of cost and emission reductions for an individual facility. Lastly, facilities may either incur minimal additional costs or realize a savings on a case-by-case basis, depending primarily on how much they currently spend to operate the high VOC content solvent-based parts cleaners, the cost of organic solvent disposal, and air emission fees levied for VOC emissions. Also, the costs and VOC reductions will differ with the option that a facility would be required to use by a State for a cleaning operation.

References

1. Bay Area Air Quality Management District, Staff Report: *Proposed Amendments to BAAQMD Regulation 8, Rule 16: Solvent Cleaning Operations, September 2002.*
2. South Coast Air Quality Management District, *Staff Report for Proposed Amendment to Rule 1171 - Solvent Cleaning Operations, August 15, 1996.*

Table 2. Summary of Costs and Emission Reductions for Nonattainment Facilities for the Recommendation Concerning Solvent Substitution

Solvent Cleaning Operation	Affected facilities with VOC emissions ≥6.8 kg per day	2002 NEI* Baseline VOC emissions (Mg/yr)	Controlled VOC for facilities in NAICS (2002 Mg/yr)	Emission Reduction for Facilities in NAICS (tpy)	Cost Effectiveness (2002 \$ per Mg)	Nationwide Cost (2002 \$)
Parts Cleaners	613	3,990	221	3,768	1,833	6,905,900
Other Solvent Cleaning Operations	2,408	59,271	3,286	55,986	-1,459	-81,697,307
Totals (100% of facilities)*	2,524	63,261	3,507	59,754		-74,791,407
Totals (75% of facilities)**	1893	47,446	2,630	44,816		-56,093,556
Totals (50% of facilities)**	1262	31,630	1,753	29,877		-37,395,704
Totals (25% of facilities)**	631	15,815	877	14,939		-18,697,852

* Some facilities have emissions from both parts cleaners and other solvent cleaning operations. The total number of facilities represents the number of facilities considered in this analysis (see Appendix C).

Attachment 1. Costs and Emission Reductions Example Calculation for the Recommendation Concerning Solvent Substitution

An example is presented to illustrate the procedure we used to calculate the cost and VOC emission reductions resulting when the recommended 50 g/l VOC limit option is applied. In this example, we show an overall negative cost, which is representative of most of the nonattainment facilities the 2002 NEI database which cleaning solvents above the threshold limit. However, the net cost for a facility, that will be using this option, will depend on the level of VOC solvent emissions from parts cleaning relative to that for the other cleaning operations.

Procedure:

- 1 Estimated baseline VOC emissions from solvent cleaning operations for the facilities in the EPA 2002 NEI database. Only emissions identified as originating from "VOC" were included, due time constraints. Individually listed compounds were not screened for VOC status. Therefore, total VOC from cleaning solvents are somewhat underestimated.
- 2 Identified the facilities in nonattainment areas that emitted VOC from the use of organic solvents above a 6.8 kg/day (15 lb/day) threshold level.
- 3 Calculate separately, as identified in the NEI database, the cost of parts cleaners and other cleaning operations.
- 4 Used an average VOC concentration of 900 g/l, which we determined from the 1994 ACT, to convert VOC emissions to volume of solvent used. For this analysis we are assuming that the VOC emissions from solvent cleaning determined from the NEI database are equal to the volume of solvent used.
- 5 Multiplied by the VOC limit (50 g/l) by solvent usage to determine the VOC emissions after compliance with the limit.
- 6 Subtracted the value determined under 5 above from the NEI baseline emissions to estimate emission reductions
- 7 Used cost-effectiveness information from the Bay Area AQMD to calculate costs of reducing VOC.

**Table 1A. Emissions from Solvent Cleaning Operations
 (8-hour Ozone Non-Attainment Area based on 2002 NEI) ***

NEI Unique Facility ID	County FIPS	SCC	VOC emissions (tpy)	Category	Pollution Category	NAICS Code	SIC Code
NEI22046	06059	40100308	0	NHPC	VOC	713110	7996
NEI22046	06059	40100398	2.17	NHPC	VOC	713110	7996
NEI22046	06059	40200210	0.08	otherNH	VOC	713110	7996
NEI22046	06059	40200310	0.04	otherNH	VOC	713110	7996
NEI22046	06059	40200410	0	otherNH	VOC	713110	7996
NEI22046	06059	40200510	0.01	otherNH	VOC	713110	7996
NEI22046	06059	40200610	0.19	otherNH	VOC	713110	7996
NEI22046	06059	40200710	0.01	otherNH	VOC	713110	7996
NEI22046	06059	40200901	0.01	otherNH	VOC	713110	7996
NEI22046	06059	40200926	0	otherNH	VOC	713110	7996
NEI22046	06059	40200998	2.02	otherNH	VOC	713110	7996
NEI22046	06059	40201901	0.01	otherNH	VOC	713110	7996
NEI22046	06059	40299995	0.64	otherNH	VOC	713110	7996
NEI22046	06059	49000601	0.47	otherNH	VOC	713110	7996

Step 1: Calculate total facility emissions of VOC from solvent cleaning operations and determine if they are above threshold level of 6.8 kg/day (15 lb/day).

$$\text{Total Facility Emissions} = 0 + 2.17 + 0.08 + 0.04 + 0 + 0.01 + 0.19 + 0.01 + 0.01 + 0 + 2.02 + 0.01 + 0.64 + 0.47 = 5.64 \text{ tpy}$$

$$\text{VOC Threshold} = 15 \text{ lb/day} * 1 \text{ ton}/2000 \text{ lb} * 365 \text{ days/yr} = 2.74 \text{ tpy}$$

$$\text{or } 2.17 \text{ ton/yr} * 907,185 \text{ g/ton} = 2,485 \text{ kg/yr (2.48 Megagrams/yr)}$$

Since the facility emissions are above the VOC threshold limit of 6.8 kg/yr, go to step 2.

Step 2: Estimate baseline emissions and emission reductions from (1) parts cleaners and (2) other solvent cleaning operations.

2a. Parts Cleaners

$$\text{The total VOC Emissions from Parts Cleaners used by this Facility} = 2.17 \text{ ton/yr} * 907.2 \text{ kg/ton} = 1,967 \text{ Kg/yr}$$

We will assume that the average VOC concentration (density) of the solvents used by this facility was 900 g/liter. If we replace the organic solvent with a cleaning solution with a VOC content (concentration) of 50 g/liter, the controlled emissions would be as follows:

$$= 1,967 \text{ kg/yr} * (50 \text{ g/liter}/900 \text{ g.liter})$$

$$= 109.2 \text{ kg/yr (0.12 ton/yr)}$$

2a. Other Cleaning Operations

*The total VOC Emissions from the Other Cleaners Operations in this Facility = 3.48 ton/yr * 907.2 kg/ton = 3,154 kg/yr*

Therefore, the controlled VOC emissions after solvent substitution are
*= 3,154 kg/yr * (50 g/liter/900 g.liter)*
= 175.2 kg/yr (0.19 ton/yr)

Step 3: Estimate the costs of switching to aqueous solvent.

3a. Parts Cleaners

Assumption \$1,664 per ton of VOC emissions reduced

Tons VOC reduced due to solvent substitution = 2.17 ton/yr – 0.12 ton/yr = 2.05 ton/yr
*Cost to Facility = \$1,664/ton reduced * 2.05 ton/yr = \$3,408*

3b. Other Solvent Cleaning Operations

Assumption -\$1,325 (net savings) per ton of VOC reduced.

Tons VOC reduced to solvent substitution = 3.48 ton/yr – 0.19 ton/yr = 3.29 ton/yr
*Cost to Facility = -\$1,325/ton reduced * 3.29 ton/yr = -\$4,351 (savings)*

3c. Calculate Total Facility Cost:

Cost from VOC reduced from Parts Cleaners + Cost from VOC reduced from Other Cleaning Operations = \$3,408 + -\$4,351 = - \$943(net savings)

This page intentionally left blank

United States
Environmental Protection
Agency

Office of Air Quality Planning and Standards
Air Quality Strategies and Standards Division
Research Triangle Park, NC

Publication No. EPA 453/R-06-001
September, 2006

Postal information in this section where appropriate.