

**CHATFIELD**

**TECHNICAL  
CONSULTING  
LIMITED**

2071 Dickson Road  
Mississauga, Ontario  
CANADA L5B 1Y8  
Telephone: (905) 896-7611  
Fax: (905) 896-1930

**DRAFT**

**Analytical Method  
for Determination of Asbestos in  
Vermiculite and Vermiculite-Containing Products**

Prepared for:

Mr. Wayne R. Toland  
U.S. Environmental Protection Agency  
1 Congress Street, Suite 1100  
Boston, MA 02114



---

Dr. Eric J. Chatfield  
President  
Chatfield Technical Consulting Limited

**DISCLAIMER**

This analytical method has not been submitted for formal peer review nor has it been tested in a competent lab to determine its accuracy and precision. As a result, EPA does not endorse, recommend, or otherwise encourage its use in any way until that process is completed. This method, which is presented here in draft form only, is being provided at your request and any decision to use it for analytical purposes rests entirely at the readers/users discretion.

## TABLE OF CONTENTS

<b>1</b>	<b>INTRODUCTION AND BACKGROUND</b>	<b>1</b>
1.1	General	1
1.2	Required Characteristics for an Analytical Method for Determination of Asbestos in Vermiculite	1
1.3	Analytical Considerations Specific to Vermiculite from Libby, Montana	2
1.4	Analytical Considerations for Vermiculite Sources Other Than Libby	3
<b>2</b>	<b>PRINCIPLE OF METHOD</b>	<b>3</b>
2.1	Background	3
2.2	Types of Measurement	4
<b>3</b>	<b>SCOPE AND FIELD OF APPLICATION</b>	<b>5</b>
3.1	Substance determined	5
3.1.1	Weight Percent Asbestos	5
3.1.2	Concentration of Respirable Fibers	6
3.2	Type of Sample	6
3.3	Range	6
3.4	Limit of Detection	6
<b>4</b>	<b>DEFINITIONS</b>	<b>8</b>
<b>5</b>	<b>ABBREVIATIONS</b>	<b>12</b>
<b>6</b>	<b>EQUIPMENT AND APPARATUS</b>	<b>12</b>
6.1	General	12
6.2	Sample preparation	13
6.3	Rapid Screening Method	13
6.4	Measurement of Respirable Fibers by TEM	13
<b>7</b>	<b>REAGENTS</b>	<b>14</b>
<b>8</b>	<b>SELECTION AND PRE-TREATMENT OF SUB-SAMPLE FOR ANALYSIS</b>	<b>14</b>
8.1	Types of Sample	14
8.2	Obtaining a Representative Sub-Sample for Analysis	15
8.3	Pre-Treatment of Sub-Samples	16
8.3.1	Background	16
8.3.2	Exfoliated Vermiculite	16
8.3.3	Potting Soil	16

8.3.4	Lawn Fertilizer	18
8.3.5	Beneficiated Crude Vermiculite Ore	18
8.3.6	Soil Samples Containing Crude Vermiculite Ore	21
8.3.7	Soil Samples Containing Exfoliated Vermiculite	21
8.3.8	Samples of insulation incorporating materials in addition to vermiculite	21
<b>9</b>	<b>PROCEDURE FOR ANALYSIS</b>	<b>23</b>
9.1	Introduction	23
9.2	Rapid Screening Analysis to Determine the Weight Percent of Amphibole Asbestos	24
9.2.1	General	24
9.2.2	Separation of Vermiculite from other Components by Flotation on Water	24
9.2.3	Optional Preparation of TEM Specimens From the Aqueous Suspension of Vermiculite	25
9.2.4	Density Adjustment of Heavy Liquid	25
9.2.5	Separation of Amphibole Fragments by Centrifugation in a Heavy Liquid	30
9.2.6	Stereo-Binocular Microscope Examination of the Centrifugate	37
9.3.1	Introduction	41
9.3.2	Separation of Coarse Vermiculite	42
9.3.3	Separation of Respirable Fibers by Displacement Sedimentation	42
9.3.4	Preparation of TEM Specimens From Displaced Suspension	43
9.3.5	Examination of TEM Specimens	49
9.4	Combined Procedure	49
<b>10</b>	<b>DATA REPORTING</b>	<b>49</b>
10.1	Rapid Screening Analysis to Determine Weight Percent of Amphibole Asbestos	49
10.2	Concentration of Respirable Fibers	50
<b>11</b>	<b>ACCURACY AND PRECISION</b>	<b>51</b>
<b>12</b>	<b>REFERENCES</b>	<b>51</b>
	<b>APPENDIX A. RECOVERY OF HEAVY LIQUIDS FOR RE-USE</b>	<b>53</b>
A.1	Background	53
A.2	Purification of Heavy Liquids by Distillation	53

# **1 INTRODUCTION AND BACKGROUND**

## **1.1 General**

As is the case for most minerals, deposits of vermiculite contain other mineral phases, and most of these other mineral phases are removed during processing. This process by which vermiculite is concentrated from the crude ore is referred to as beneficiation. During beneficiation of crude vermiculite ore, the vermiculite is also segregated into different size fractions for different applications. Larger sizes of vermiculite flakes command a higher price.

Most deposits of vermiculite that are the sources of current production contain low concentrations of amphibole minerals, and some of these fragments of amphibole may have chemical compositions that are within the ranges of the regulated amphibole asbestos species. However, these amphibole fragments are usually present in a non-asbestiform crystal habit. Rarely, a small proportion of the amphibole may be present in a fibrous crystalline habit, conforming to the conventional definition of asbestos. During beneficiation, much of any non-asbestiform amphibole or amphibole asbestos present in the original ore is separated, but some of the material passes through the beneficiation process and appears in the beneficiated vermiculite.

Chrysotile has not been detected in any of the vermiculite marketed in North America. Moreover, chrysotile would be unlikely to survive the exfoliation process, since the temperatures used for exfoliation exceed those at which chrysotile degrades. Some vermiculite, particularly that from the Republic of South Africa, contains scrolls of vermiculite which are short and exhibit morphological features similar to those of chrysotile. However, these scrolls can be discriminated from chrysotile by transmission electron microscopy (Chatfield and Lewis, 1980)

## **1.2 Required Characteristics for an Analytical Method for Determination of Asbestos in Vermiculite**

Vermiculite is normally used as purchased, and there are no uses for which it is necessary to grind or pulverize vermiculite to a powder. Accordingly, any risks presented by use of vermiculite are those presented by the material as used, and the analytical method should measure the required parameter without crushing of the vermiculite. If vermiculite is pulverized or crushed prior to analysis, the results of the analysis will probably mis-represent any risks associated with its use. In particular, crushing of any associated non-asbestiform amphibole fragments will generate numerous cleavage fragments which will complicate the interpretation of

the results. This is because these cleavage fragments were not present as such in the material as used, and once they are generated, the analytical methods cannot always discriminate between these cleavage fragments and fibers of true asbestos.

Assuming that amphibole fragments are present in the beneficiated vermiculite, the amount of amphibole present in the final exfoliated product depends on the practices of the exfoliation facility. During exfoliation, the vermiculite expands to 5 - 15 times its original volume, and these very light fragments are separated by air entrainment. The other minerals present in the original beneficiated vermiculite are not useful, and represent material (usually referred to as "rock") that must be disposed of by the exfoliation facility. Some facilities return the "rock" to the vermiculite after the exfoliation process, and it is therefore incorporated into the final product. Other facilities dispose of the "rock" as a waste material. The importance of this to the analyst is that non-vermiculite fragments may be common in some samples but relatively rare in others.

Transmission electron microscopy (TEM) is not an appropriate method for determination of the weight percent amphibole asbestos in vermiculite, because the size range of fiber bundles of amphibole asbestos that may be present in vermiculite extends up to approximately the dimensions of the vermiculite flakes, and the majority of the weight of amphibole asbestos is represented by these larger fiber bundles that are very much larger than can be examined by TEM. Any attempt to measure the weight concentration by TEM will usually yield a value that significantly under-estimates the actual concentration.

TEM is an appropriate method for determination of the numerical concentration of respirable fibers, and is, in fact, the only method by which an accurate determination can be made. An analytical method, therefore, must incorporate a procedure by which respirable fibers can be separated from the bulk material, without generating additional respirable fibers by crushing or grinding of the material.

It is most important to recognize that reliable and reproducible results cannot be obtained by analysis of small samples. Any amphibole particles present in vermiculite are usually much fewer in number than the flakes of vermiculite, and if only a small sample size is analyzed the number of amphibole particles included in the sample will be small and often unrepresentative.

### **1.3 Analytical Considerations Specific to Vermiculite from Libby, Montana**

Prior to 1990, a large proportion of the U.S. consumption of vermiculite

originated from the mine at Libby, Montana. The vermiculite originating from this mine was quite unique in that substantial concentrations of amphibole asbestos were present, and in this respect it was unlike vermiculite from any other source. During the life of the Libby mine, attempts were made to reduce the level of amphibole asbestos in the beneficiated vermiculite, but it was never possible to remove it completely. Depending on the date of production, beneficiated vermiculite from Libby may have contained several percent of amphibole asbestos, down to a fraction of a percent shortly before the mine was closed in 1990.

From an analytical perspective, it is important to recognize that, with relatively simple, but appropriate, analytical procedures specified in this method, the amphibole asbestos in vermiculite from the Libby mine can be readily recognized and the weight percent of amphibole asbestos reliably determined in the range of less than approximately 0.01% to several percent by weight. This measurement can be made using conventional chemical laboratory equipment, a stereo-binocular microscope and a polarized light microscope. Samples of products containing vermiculite from the Libby mine will generally yield sufficient amphibole asbestos to determine the approximate weight concentration by weighing.

#### **1.4 Analytical Considerations for Vermiculite Sources Other Than Libby**

Analysis of vermiculite from current production is generally a matter of establishing a sufficiently low limit of detection, and distinguishing between asbestiform and non-asbestiform amphibole fragments.

## **2 PRINCIPLE OF METHOD**

### **2.1 Background**

If handling of a particular vermiculite sample and its associated mineral fragments presents any risk, the risk is represented by the vermiculite as it is normally used. Therefore, in this analytical method, the vermiculite is analyzed in the condition that it is normally used, and it is not crushed. Crushing of vermiculite samples prior to analysis misrepresents any hazards and introduces ambiguities of interpretation as follows:

- (a) if asbestiform minerals are present in vermiculite, the fibers and fiber bundles usually have a large size spectrum ranging from a few micrometers in length up to the size of the vermiculite flakes themselves. The risk, therefore, results from only those fibers and

fiber bundles that have diameters lower than the upper limit of respirability;

- (b) if fragments of non-asbestiform amphibole are present in vermiculite, they are usually large and very few of them have diameters within the respirable size range. However, if the material is crushed, any non-asbestiform amphibole fragments present will cleave along crystal planes to generate large numbers of countable fibers that are not representative of the material as it is used. Moreover, after such crushing, the only way to determine whether the amphibole fibers measured originated from amphibole asbestos or from cleavage of non-asbestiform amphibole fragments is to measure the lengths and widths of several hundred fibers and then to examine the aspect ratio distribution. In this case, the fibers being measured would not have been present in the original material, and reporting of these fibers as asbestos would be misleading.

## 2.2 Types of Measurement

Two types of measurement are specified in this method.

- (a) A rapid screening procedure for determination of the weight percent amphibole or the weight percent amphibole asbestos is specified. For this measurement, a known weight of the sample containing exfoliated vermiculite is first suspended in water. Most of the vermiculite floats to the top of the suspension, and this vermiculite is removed and discarded. After allowing time for most of the suspended material to settle, the water is decanted, and the sediment is dried and weighed. The dried sediment, or a known weight of it, is placed into a centrifuge tube and suspended in a heavy liquid of density 2.75. After centrifuging, the centrifugate is separated and weighed. The centrifugate is examined under a stereo-binocular microscope. If there is more than approximately 0.01% of amphibole asbestos in the original sample, the fiber bundles are readily recognized during the stereo-microscope examination, and it is possible to hand-pick these fiber bundles from the centrifugate and weigh them. Representative amphibole particles are identified by PLM, with confirmation by either SEM-EDXA or TEM-EDXA if necessary.
- (b) A TEM procedure is specified for determination of the number of

respirable fibers per gram of sample, or per gram of respirable particles. This procedure can be applied to samples containing exfoliated vermiculite, samples containing unexfoliated vermiculite, or crude vermiculite ore. The sample is first suspended in room temperature distilled water, and any floating material is removed. Colder water is then introduced at the base of the container such that the vertical rate of filling is equivalent to the falling speed of the maximum-sized respirable particle. The displaced suspension is collected, and the admission of cold water is terminated when all of the original suspension has been displaced. The displaced and collected suspension contains all of the respirable particles. Aliquots of the suspension are filtered through membrane filters, and TEM specimens are prepared from the filters. The TEM specimens are examined, and fibers are identified and their dimensions are recorded. The balance of the suspension is filtered on to a pre-weighed membrane filter. The filter is dried and weighed to obtain the weight of respirable particles.

If the rapid screening determination of weight percent amphibole and the concentration of respirable fibers are both required, it is possible to combine the two procedures during processing of the sample.

In order to obtain an acceptable detection limit for determination of the weight percent asbestos in vermiculite, the method relies on density separation methods to remove as much of the vermiculite as possible prior to microscopical analysis. Organic materials, if present, are removed by treatment of the sample in a muffle furnace. If the sample contains unexfoliated vermiculite, the sample is exfoliated either thermally or chemically in order to allow the maximum degree of separation of the vermiculite by density separation methods.

### **3 SCOPE AND FIELD OF APPLICATION**

#### **3.1 Substance determined**

##### **3.1.1 Weight Percent Asbestos**

The rapid screening method specifies a procedure to determine the weight percent of amphibole asbestos.



### **3.1.2 Concentration of Respirable Fibers**

The method specifies a TEM procedure to determine the concentration of respirable asbestos fibers in vermiculite or vermiculite-containing samples. The concentration of respirable asbestos fibers is expressed as the numerical concentration per gram of sample, and as the numerical concentration per gram of potentially respirable particulate material. The lengths, widths and aspect ratios of the asbestos fibers and bundles are measured. The method allows determination of the type(s) of asbestos fibers present. As for all routine TEM analytical methods, this TEM method cannot discriminate between an individual fiber of the asbestos and non-asbestos analogues of the same amphibole mineral.

### **3.2 Type of Sample**

The method is defined for solid samples containing vermiculite, including beneficiated vermiculite, loose fill attic insulation, horticultural vermiculite, potting soil, slow release horticultural fertilizers and fireproofing materials.

### **3.3 Range**

The range of amphibole asbestos weight concentration that can be measured is approximately 0.01% to 100%.

The minimum respirable fiber concentration that can be measured is dependent on the volume of the suspension that can be filtered while still yielding filters that are appropriately-loaded for preparation of TEM specimens. The minimum for the respirable fiber concentration can be lowered by examination of a larger area of the TEM specimens. There is no maximum, since the analytical parameters can always be adjusted to accommodate high fiber concentrations. For a sub-sample of 50 grams, it is usually possible to filter approximately 0.3 mL of the suspension without overloading of the filter, and examination of 19 grid openings of the TEM specimens yields an analytical sensitivity of approximately 100,000 fibers/g of original sample. However, the actual analytical sensitivity that can be achieved is dependent on the nature of the sample.

### **3.4 Limit of Detection**

For the rapid screening method, the limit of detection for amphibole asbestos is less than approximately 0.01% by weight.

Theoretically, for determination of the concentration of respirable fibers, the limit of detection can be lowered indefinitely by increasing the volume of liquid filtered during specimen preparation, and by increasing the area of the TEM specimens examined in the electron microscope. In practice, for a particular area of TEM specimens examined, the lowest achievable limit of detection is controlled by the total amount of particulate material in the respirable size range. There is an upper limit to the volume of the final suspension that can be filtered, if TEM specimens of appropriate particulate loading are to be obtained. Lower limits of detection can be achieved by increasing the area of the TEM specimens that is examined. In order to achieve lower limits of detection for fibers and bundles longer than 5  $\mu\text{m}$ , and for PCM equivalent fibers, lower magnifications are specified which permit more rapid examination of larger areas of the TEM specimens when the examination is limited to these dimensions of fiber.

# DRAFT

## 4 DEFINITIONS

**Acicular:** The shape shown by an extremely slender crystal with cross-sectional dimensions which are small relative to its length, i.e. needle-like.

**Amphibole:** A group of rock-forming ferromagnesium silicate minerals, closely related in crystal form and composition, and having the nominal formula:

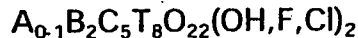

where:

A = K, Na;

B = Fe<sup>2+</sup>, Mn, Mg, Ca, Na;

C = Al, Cr, Ti, Fe<sup>3+</sup>, Mg, Fe<sup>2+</sup>;

T = Si, Al, Cr, Fe<sup>3+</sup>, Ti.

In some varieties of amphibole, these elements can be partially substituted by Li, Pb, or Zn. Amphibole is characterized by a cross-linked double chain of Si-O tetrahedra with a silicon:oxygen ratio of 4:11, by columnar or fibrous prismatic crystals and by good prismatic cleavage in two directions parallel to the crystal faces and intersecting at angles of about 56° and 124°.

**Amphibole asbestos:** Amphibole in an asbestiform habit.

**Analytical filter:** A filter through which an aqueous suspension of particles is passed, and from which TEM specimen grids are prepared.

**Analytical sensitivity:** The calculated asbestos structure concentration in asbestos structures/g, equivalent to counting of one asbestos structure in the analysis.

**Asbestiform:** A specific type of mineral fibrosity in which the fibers and fibrils possess high tensile strength and flexibility.

**Asbestos:** A term applied to a group of silicate minerals belonging to the serpentine and amphibole groups which have crystallized in the asbestiform habit, causing them to be easily separated into long, thin, flexible, strong fibers when crushed or processed. The Chemical Abstracts Service Registry Numbers of the most common asbestos varieties are: chrysotile (12001-29-5), crocidolite (12001-28-4), grunerite asbestos (Amosite) (12172-73-5), anthophyllite asbestos (77536-67-5), tremolite asbestos (77536-68-6) and actinolite asbestos

(77536-66-4). Less common asbestos varieties include the amphibole minerals richterite and winchite in asbestiform habits.

**Asbestos structure:** A term applied to an individual fiber, or any connected or overlapping grouping of asbestos fibers or bundles, with or without other particles.

**Aspect ratio:** The ratio of length to width of a particle.

**Beneficiation:** The process in which vermiculite is concentrated from the crude ore and separated into different size fractions.

**Blank:** A structure count made on TEM specimens prepared from an unused filter, to determine the background measurement.

**Camera length:** The equivalent projection length between the specimen and its electron diffraction pattern, in the absence of lens action.

**Chrysotile:** A fibrous mineral of the serpentine group which has the nominal composition:

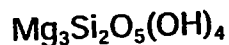

Most natural chrysotile deviates little from this nominal composition. In some varieties of chrysotile, minor substitution of silicon by  $\text{Al}^{3+}$  may occur. Minor substitution of magnesium by  $\text{Al}^{3+}$ ,  $\text{Fe}^{2+}$ ,  $\text{Fe}^{3+}$ ,  $\text{Ni}^{2+}$ ,  $\text{Mn}^{2+}$  and  $\text{Co}^{2+}$  may also be present. Chrysotile is the most prevalent type of asbestos.

**Cleavage:** The breaking of a mineral along one of its crystallographic directions.

**Cleavage fragment:** A fragment of a crystal that is bounded by cleavage faces.

**Cluster:** An structure in which two or more fibers, or fiber bundles, are randomly oriented in a connected grouping.

**Density separation:** A procedure in which particles of different densities are separated by suspension in a liquid of selected density.

**d-spacing:** The distance between identical adjacent and parallel planes of atoms in a crystal.

**Electron diffraction:** A technique in electron microscopy by which the crystal structure of a specimen is examined.

**Electron scattering power:** The extent to which a thin layer of substance scatters electrons from their original directions.

**Energy dispersive X-ray analysis:** Measurement of the energies and intensities of X-rays by use of a solid state detector and multi-channel analyzer system.

**Eucentric:** The condition when the area of interest of an object is placed on a tilting axis at the intersection of the electron beam with that axis and is in the plane of focus.

**Exfoliation:** A process in which vermiculite flakes are expanded by sudden heating or by chemical action.

**Falling speed:** The speed at which a particle falls through a fluid when the downward force due to the particle mass is in equilibrium with the resistive force due to viscosity of the fluid.

**Fibril:** A single fiber of asbestos, which cannot be further separated longitudinally into smaller components without losing its fibrous properties or appearances.

**Fiber:** An elongated particle which has parallel or stepped sides. A fiber is defined as having an aspect ratio equal to or greater than 5:1 and a minimum length of 0,5  $\mu\text{m}$ .

**Fiber bundle:** A structure composed of parallel, smaller diameter fibers attached along their lengths. A fiber bundle may exhibit diverging fibers at one or both ends.

**Fibrous structure:** A fiber, or connected grouping of fibers, with or without other particles.

**Funnel blank:** A structure count made on TEM specimens prepared by the direct-transfer method from a filter used for filtration of a sample of distilled water.

**Habit:** The characteristic crystal growth form or combination of these forms of a mineral, including characteristic irregularities.

**Limit of detection:** The calculated airborne asbestos structure concentration in structures/g, equivalent to counting of 2,99 asbestos structures in the analysis.

**Matrix:** A structure in which one or more fibers, or fiber bundles, touch, are

attached to, or partially concealed by, a single particle or connected group of non-fibrous particles.

**Miller index:** A set of either three or four integer numbers used to specify the orientation of a crystallographic plane in relation to the crystal axes.

**PCM equivalent fiber:** A fiber of aspect ratio greater than or equal to 3:1, longer than 5 µm, and which has a diameter between 0,2 µm and 3,0 µm.

**Replication:** A procedure in electron microscopy specimen preparation in which a thin copy, or replica, of a surface is made.

**Respirable fiber:** A fiber of aspect ratio greater than or equal to 3:1, longer than 5 µm, and which has a diameter equal to or lower than 3,0 µm.

**Selected area electron diffraction:** A technique in electron microscopy in which the crystal structure of a small area of a sample is examined.

**Serpentine:** A group of common rock-forming minerals having the nominal formula:

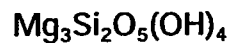

**Spherical Equivalent Diameter:** The diameter of a sphere of unit density that has the same falling speed in air as the particle under consideration.

**Structure:** A single fiber, fiber bundle, cluster or matrix

**Twinning:** The occurrence of crystals of the same species joined together at a particular mutual orientation, and such that the relative orientations are related by a definite law.

**Unopened fiber:** A large diameter asbestos fiber bundle which has not been separated into its constituent fibrils or fibers.

**Zone-axis:** The line or crystallographic direction through the center of a crystal which is parallel to the intersection edges of the crystal faces defining the crystal zone.

## **5 ABBREVIATIONS**

<b>DMF</b>	-	Dimethyl formamide
<b>ED</b>	-	Electron diffraction
<b>EDXA</b>	-	Energy dispersive X-ray analysis
<b>FWHM</b>	-	Full width, half maximum
<b>HEPA</b>	-	High efficiency particle absolute
<b>MEC</b>	-	Mixed esters of cellulose
<b>PC</b>	-	Polycarbonate
<b>PCM</b>	-	Phase contrast optical microscopy
<b>SAED</b>	-	Selected area electron diffraction
<b>SEM</b>	-	Scanning electron microscope
<b>STEM</b>	-	Scanning transmission electron microscope
<b>TEM</b>	-	Transmission electron microscope
<b>UICC</b>	-	Union Internationale Contre le Cancer

## **6 EQUIPMENT AND APPARATUS**

### **6.1 General**

General laboratory equipment, such as glass beakers, disposable pipets, disposable plastic beakers and measuring cylinders, is required, with the addition of the specific items listed below. Some analyses do not require all of the equipment listed.

## **6.2 Sample preparation**

- 6.2.1 Laboratory balance, sensitivity 0.0001 gram
- 6.2.2 Muffle furnace, temperature range up to 800°C
- 6.2.3 Fused silica tray, approximately 15 cm x 9 cm
- 6.2.4 Laboratory magnetic stirrer
- 6.2.5 Teflon coated magnetic stirrer bars

## **6.3 Rapid Screening Method**

- 6.3.1 SINK-FLOAT® Standard, density  $2.75 \pm 0.005$  g/cc at 23°C. Cargille Laboratories, Inc., Cedar Grove, New Jersey 07009.
- 6.3.2 Centrifuge, capable of 3600 rpm and accommodating four or more 15 mL centrifuge tubes
- 6.3.3 Water aspirator
- 6.3.4 Stereo-binocular microscope, 10x to 40x magnification
- 6.3.5 Polarized light microscope
- 6.3.6 Scanning electron microscope, with energy dispersive x-ray analysis system

## **6.4 Measurement of Respirable Fibers by TEM**

- 6.4.1 Peristaltic pump capable of pumping 15-25 mL/minute
- 6.4.2 Glass filtration system, 25 mm diameter
- 6.4.3 Transmission electron microscope, as specified in ISO 13794
- 6.4.4 Energy dispersive x-ray analysis system, as specified in ISO 13794



## **7 REAGENTS**

7.1 High density liquid, either 1-1-2-2-tetrabromoethane or tribromomethane

7.2 Ethanol, reagent grade

7.3 Reagent water, either freshly-distilled or deionized water, filtered through an MCE filter of maximum porosity 0.22  $\mu\text{m}$ , and meeting the requirements of ASTM D 1193 for reagent water.

Note: For analyses incorporating TEM specimen preparation, it is important that the reagent water be freshly produced and filtered, in order to minimize bacterial interferences on TEM specimens.

7.4 Dimethylformamide, reagent grade

7.5 Acetone, reagent grade

7.6 Glacial acetic acid, reagent grade

7.7 Diaminoethane, reagent grade

7.8 Hydrochloric acid, concentrated reagent grade

## **8 SELECTION AND PRE-TREATMENT OF SUB-SAMPLE FOR ANALYSIS**

### **8.1 Types of Sample**

Samples presented for analysis may include:

- (a) Exfoliated vermiculite used as loose-fill attic insulation or as horticultural soil conditioner;
- (b) Potting soil containing vermiculite, peat moss, fertilizers and other constituents;
- (c) Beneficiated crude vermiculite ore, which is the form in which vermiculite is transported from a mine to an exfoliation facility;
- (d) Soil samples containing exfoliated vermiculite, originating from land to which vermiculite products have been applied in the past;

# DRAFT

- (e) Soil samples containing crude vermiculite ore, such as could be found on the ground in the vicinity of vermiculite mines or vermiculite exfoliation facilities;
- (f) Samples of insulation incorporating materials in addition to vermiculite.

## 8.2 Obtaining a Representative Sub-Sample for Analysis

Products such as potting soil often have a substantial water content, and such products shall be dried before analysis. The sample shall be weighed before and after drying to obtain the weight of water, so that the final results can be expressed in terms of the original weight or dry weight of the sample.

If amphibole is present in a vermiculite product, the size range of the fragments of amphibole is usually approximately the same as that of the vermiculite flakes, because during the beneficiation process the material is segregated into several different size categories. The fragments of amphibole are distributed randomly throughout the vermiculite, and the number of these fragments is generally much lower than the numbers of vermiculite flakes. Accordingly, if a reproducible analysis is to be obtained, it is necessary to select a sub-sample of vermiculite sufficiently large that a statistically-valid number of the amphibole fragments are included. The weight of sub-sample required is dependent on the size grade of the vermiculite, and the percentage of vermiculite in the sample. Table 1 gives recommended approximate weights of vermiculite that should be used for the initial sub-sample. For products containing vermiculite, a visual estimate of the proportion of vermiculite in the product should be made and the starting weights in Table 1 should be proportionately increased.

**Table 1. Recommended Sub-Sample Weights of Vermiculite for Analysis**

Size of Vermiculite Flakes, mm	Recommended Minimum Starting Weight for Analysis, grams
< 2	5
> 2 · < 5	10
> 5	50

The sub-sample shall be obtained from the original sample by the cone and quarter method. On a clean surface, such as a sheet of aluminum foil, form the sample into a cone. Using a thin flat sheet of metal or rigid plastic, divide the cone into two parts, vertically from the apex. Form either of the two fractions into a cone, and repeat the procedure until one of the separate fractions is of a suitable weight for analysis.

### **8.3 Pre-Treatment of Sub-Samples**

#### **8.3.1 Background**

In order to obtain the best detection limits and reproducibility for determination of asbestos, pre-treatment is required for samples other than exfoliated vermiculite. The pre-treatments are summarized in the flow-chart shown in Figure 1. This analytical method is based on selective removal of exfoliated vermiculite by water flotation, so any sample that contains unexfoliated vermiculite shall be exfoliated prior to analysis. If the analyses are intended to measure only amphibole asbestos, exfoliation in a muffle furnace may be used. As is the case for industrial exfoliation, chrysotile is unlikely to survive the thermal treatment received during laboratory exfoliation, since chrysotile degrades at temperatures exceeding approximately 500°C.

#### **8.3.2 Exfoliated Vermiculite**

Exfoliated vermiculite, as marketed for application as loose attic fill insulation or for horticultural use, requires no pre-treatment before analysis. Vermiculite insulation samples originating from attics, and samples identified as horticultural vermiculite may be submitted directly to the analytical procedure.

#### **8.3.3 Potting Soil**

Vermiculite may represent only a fraction of the weight of potting soil. The other components are generally organic, with some plant nutrients. Water may also represent a significant proportion of the weight. The results of the analysis should generally be expressed in terms of dry weight, because the water content may vary depending on the storage conditions. Weigh a container (a disposable container formed from aluminum foil is suitable), place the sub-sample in the container and weigh again. Dry the sub-sample for a period of approximately

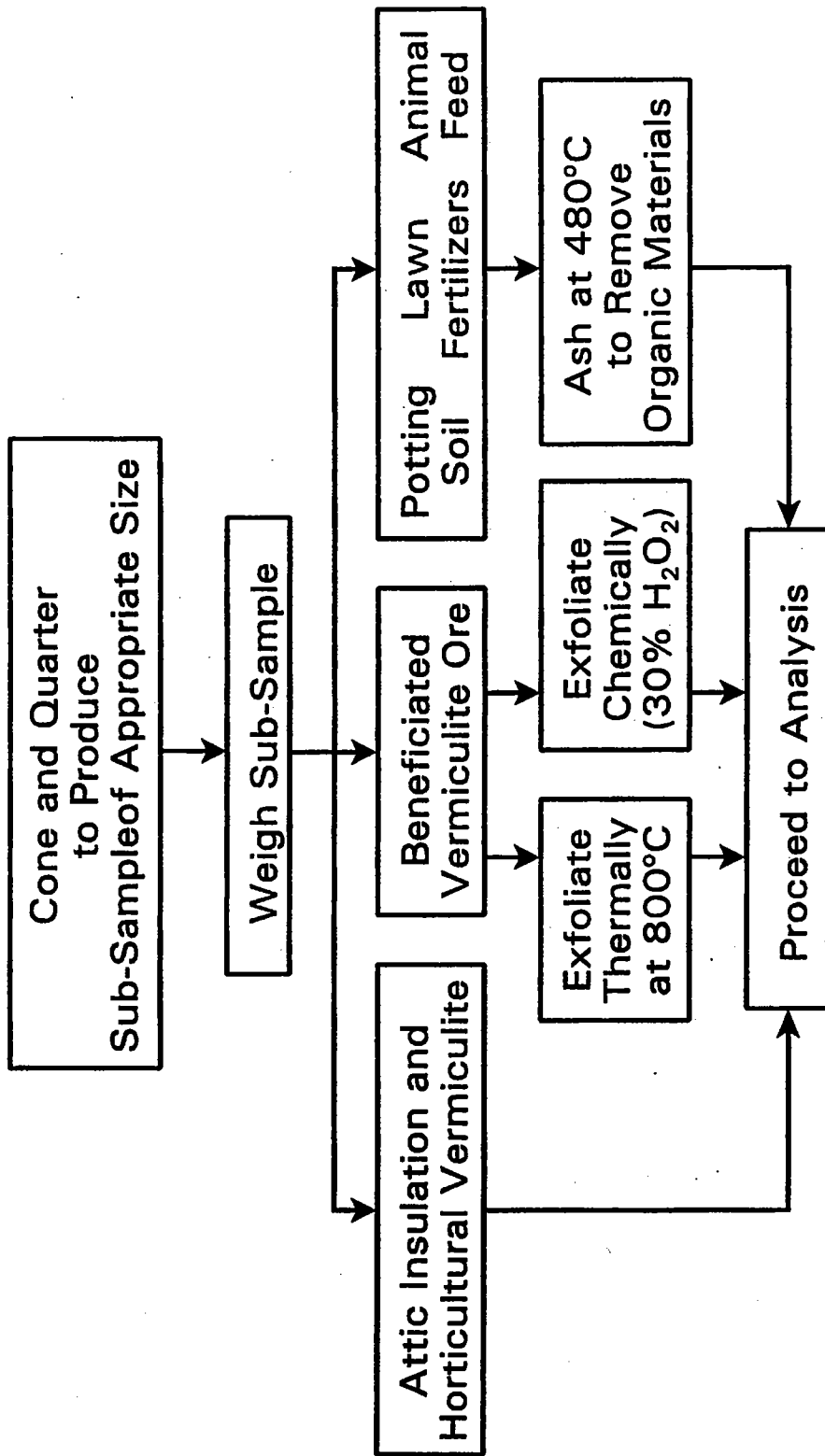

Figure 1. Pre-treatment of samples containing vermiculite

10 hours, either on a slide warmer or in an oven at a temperature of approximately 60°C, and then re-weigh. Calculate the weight of water evaporated from the sample.

Transfer the sub-sample to a fused quartz tray or other suitable open container for ashing at 480°C. Place the sub-sample in a muffle furnace operating at a temperature of 480± 10°C for a period of approximately 10 hours. Weigh the residual ash, and calculate the percentage as a proportion of the original dried sub-sample. The residual ash may be submitted directly to the analytical procedure.

#### 8.3.4 Lawn Fertilizer

Vermiculite-based lawn fertilizers contain water-soluble plant nutrients and sometimes organic herbicides. Vermiculite generally represents only a small proportion of the weight. Although it is possible to dissolve out most of the nutrients and herbicides by extraction with hot water,

#### 8.3.5 Beneficiated Crude Vermiculite Ore

The analytical procedure takes advantage of the low density of exfoliated vermiculite to allow separation of the majority of the vermiculite by flotation on water. Samples of beneficiated crude vermiculite ore must therefore be exfoliated prior to analysis. There are two ways by which beneficiated vermiculite can be exfoliated.

- (a) The vermiculite can be exfoliated at high temperature in a muffle furnace, which simulates the manner in which vermiculite is exfoliated commercially. This procedure is rapid and inexpensive. Weigh the sub-sample of vermiculite. An example of a sub-sample of beneficiated vermiculite is shown in Figure 2. Set the temperature of the muffle furnace to 800°C, and place a fused silica tray into the furnace. Have available a large glass or metal container available to receive the exfoliated vermiculite. A sheet of aluminum foil, formed into a container, has been found satisfactory. Using crucible tongs, remove the silica tray from the muffle furnace. The tray will be at a red heat. Sprinkle a small amount of the vermiculite sample into the silica tray as shown in Figure 3. Return the silica tray to the muffle furnace, as shown in Figure 4, and close the furnace door for approximately 15 seconds to complete the exfoliation. Remove the silica tray from the muffle furnace,

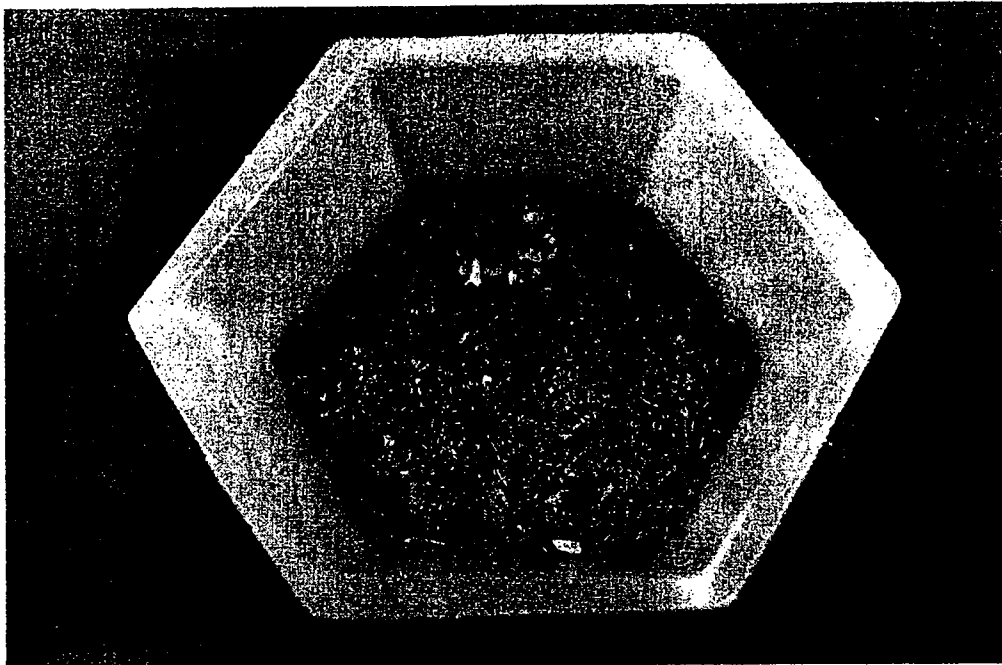

**Figure 2 Example of Sub-Sample of Beneficiated Vermiculite**

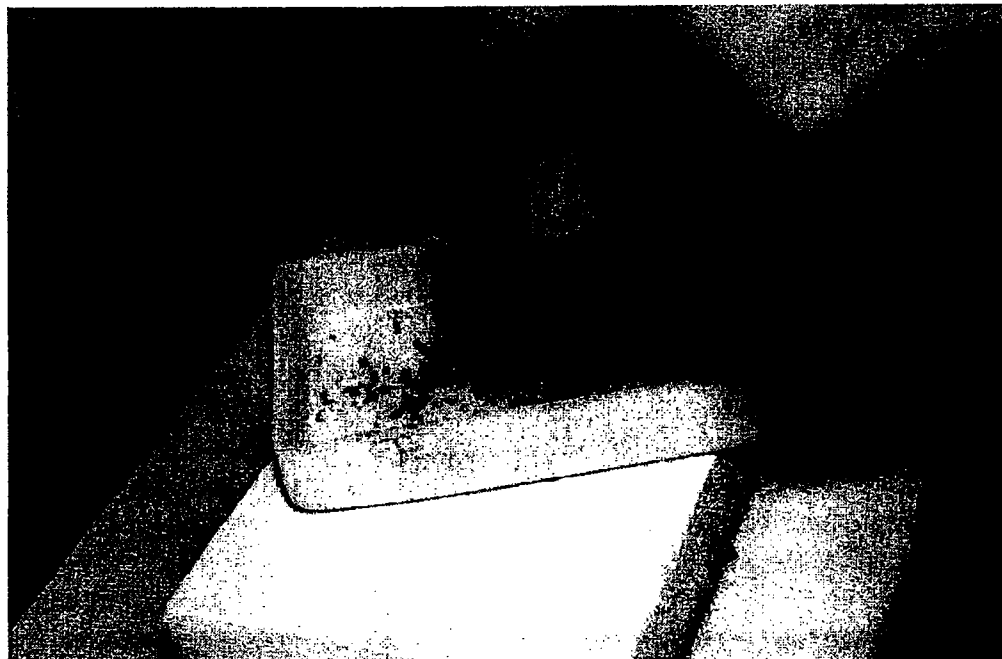

**Figure 3 Sprinkling of Beneficiated Vermiculite into Heated Silica Tray**

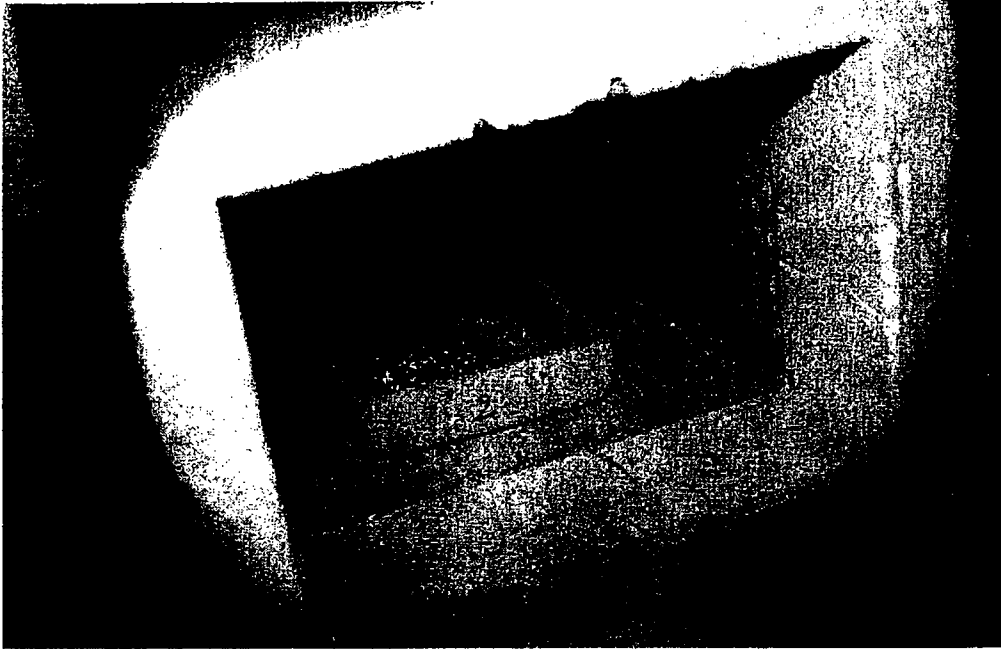

**Figure 4** Portion of Sub-Sample Before Exfoliation in Muffle Furnace

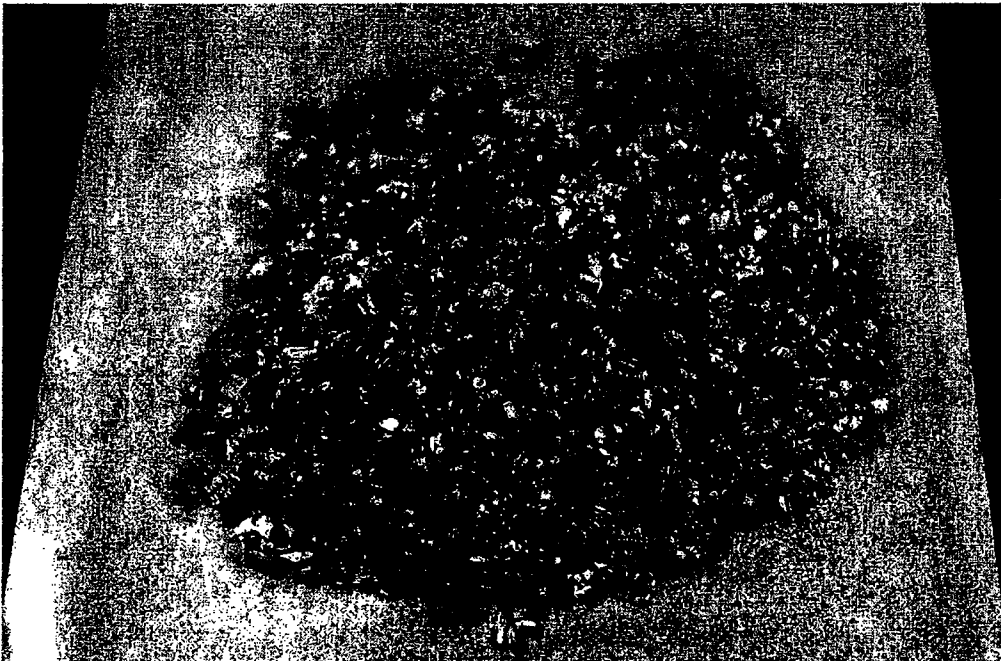

**Figure 5** Example of Exfoliated Sub-Sample

and pour the exfoliated vermiculite into the container. Repeat this procedure as many times as necessary, until all of the vermiculite has been exfoliated. The exfoliated product is shown in Figure 5

- (b) The vermiculite can be exfoliated chemically, using 30% hydrogen peroxide solution. This procedure permits the vermiculite to be exfoliated at low temperatures. As shown in Figure 6, place the vermiculite sub-sample into a glass beaker sufficiently large to accommodate the volume of the exfoliated product. Add 30% hydrogen peroxide, equal to approximately twice the volume of the vermiculite, and allow the container to stand for approximately 48 hours at room temperature. The sub-sample will exfoliate as shown in Figures 7 and 8. Dry the exfoliated product either on a hotplate or in an oven.

#### 8.3.6 Soil Samples Containing Crude Vermiculite Ore

Soil samples containing crude (unexfoliated) vermiculite ore probably also contain organic constituents which need to be removed prior to analysis. Exfoliation in a muffle furnace is the optimum approach, because in one operation the vermiculite is exfoliated and the organic constituents are oxidized. However, if chrysotile is suspected to be present and is of concern, the organic materials may be oxidized in a muffle furnace at a temperature of 480°C and the vermiculite may then be exfoliated chemically using 30% hydrogen peroxide as described in 8.3.5.

#### 8.3.7 Soil Samples Containing Exfoliated Vermiculite

Soils which have been amended with products containing exfoliated vermiculite will probably also contain substantial amounts of organic materials. The organic constituents shall be oxidized in a muffle furnace at 480°C.

#### 8.3.8 Samples of insulation incorporating materials in addition to vermiculite.

Vermiculite-based insulation and fireproofing products often contain as much as 60% of other materials such as gypsum and calcium carbonate, and also possibly chrysotile. Constituents such as gypsum and calcium carbonate can be removed by treatment in 10% hydrochloric acid, without affecting the vermiculite. If chrysotile is present, the treatment will cause the refractive indices to be lowered slightly, but the optical properties of any amphibole asbestos present will not be affected.



DRAFT

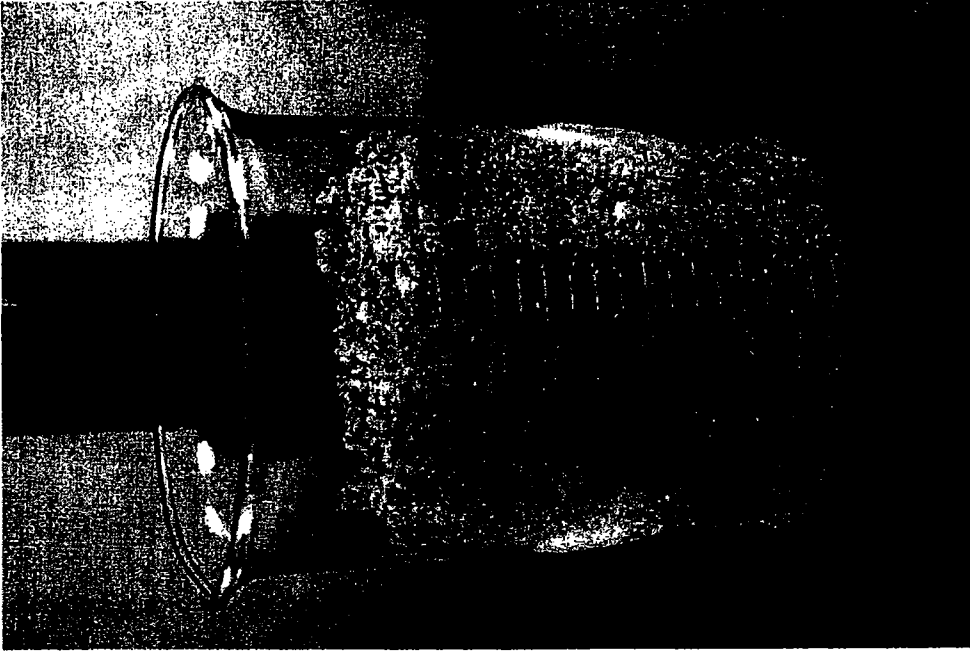

Figure 7 Sub-Sample of Beneficiated Vermiculite  
After Chemical Exfoliation

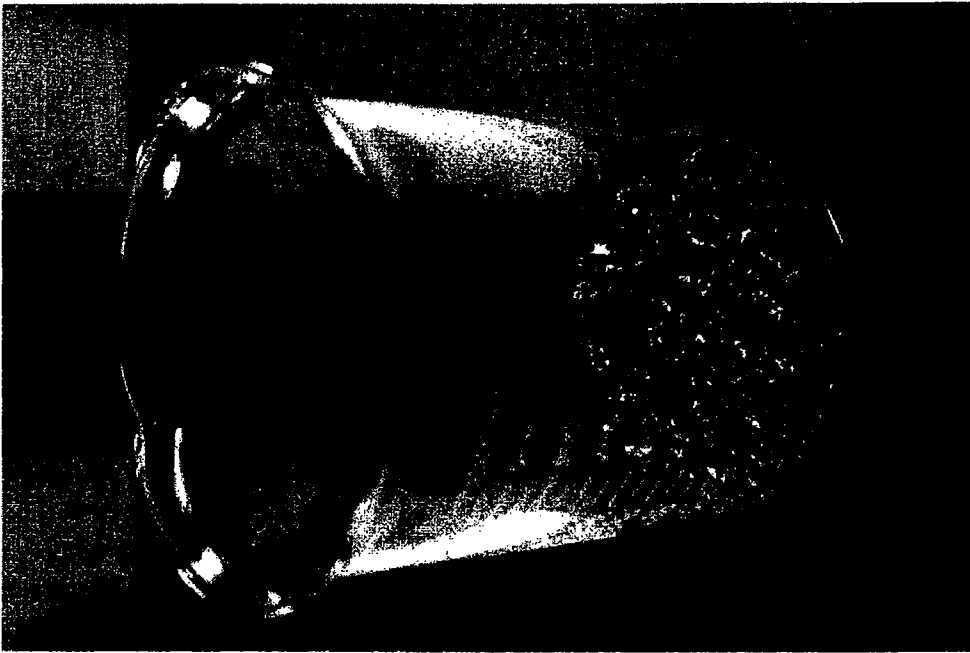
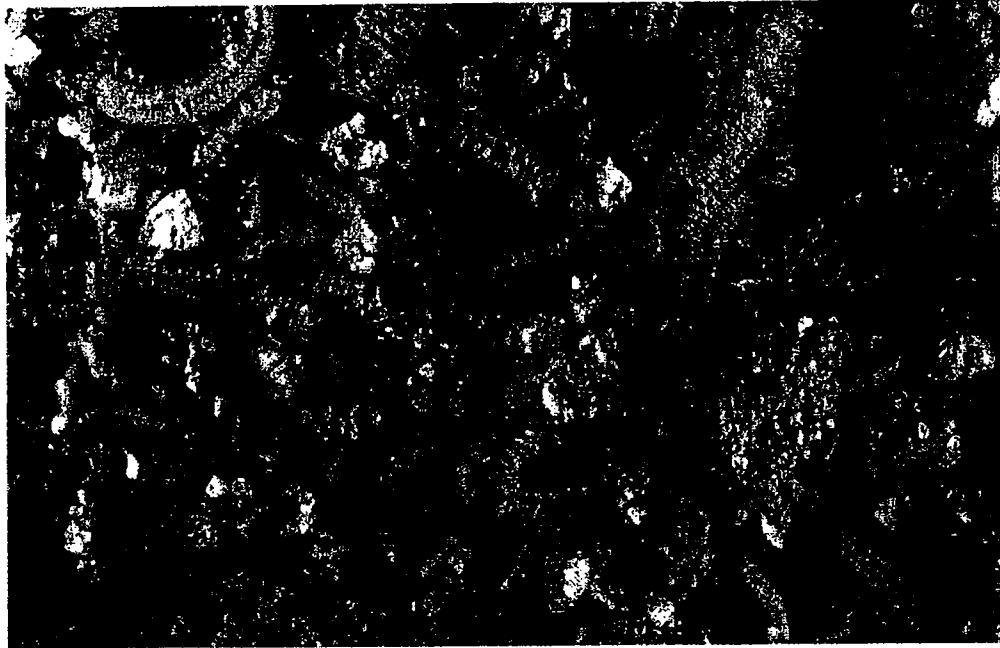

Figure 6 Sub-Sample of Beneficiated Vermiculite  
Before Chemical Exfoliation



**Figure 8 Appearance of Vermiculite After Chemical Exfoliation**

Gently break the product into fragments of about 0.5 cm dimension, using a mortar and pestle. The purpose of this crushing is to facilitate the dissolution of the carbonates and gypsum by hydrochloric acid. Place the product into a beaker with a Teflon coated magnetic stirring bar. Add an excess of 10% hydrochloric acid. The amount of acid to be added is dependent on the weight of the sample and the proportion of carbonates and gypsum. For gypsum, the solubility in water is approximately 2.4 g/L. Perform the dissolution procedure at room temperature, because gypsum is unusual in that its solubility in water reduces with increase of temperature. Stir the suspension for approximately 15 minutes, and filter using a pre-weighed polycarbonate filter of maximum pore size 0.8  $\mu\text{m}$ . Dry and weigh the filtered residue.

## **9 PROCEDURE FOR ANALYSIS**

### **9.1 Introduction**

In some situations, it is required only to determine if amphibole asbestos is present, and if so, to determine the percentage by weight. In this case, the rapid screening analysis as described in 9.2 should be used. The rapid screening analysis also incorporates an optional TEM procedure to be used if no amphibole

asbestos is detected in the residue from the analysis. This TEM examination can give additional assurance that asbestos is not present.

In other situations, the number of respirable fibers per gram of the respirable dust fraction, or the number of respirable fibers per gram of original sample is required. The analysis as described in 9.3 should be used. If all three measurements are required for the same sample, the analysis described in 9.4 should be used.

## **9.2 Rapid Screening Analysis to Determine the Weight Percent of Amphibole Asbestos**

### **9.2.1 General**

The rapid screening analysis is designed to determine the weight percent of amphibole asbestos in an exfoliated vermiculite sample, in which the particle sizes range up to some millimeters in dimension. Figure 9 shows a flow-chart which summarizes the analytical procedure.

### **9.2.2 Separation of Vermiculite from other Components by Flotation on Water**

Place 800 mL of reagent water into a 1000 mL glass beaker. Using a spoon, place a portion of the exfoliated vermiculite sub-sample into the beaker, and immerse the vermiculite several times by pushing it under the surface using the spoon. Remove the floating vermiculite and discard it. Continue to wash portions of the vermiculite in this manner until all of the sub-sample has been treated. Carefully remove all fragments of vermiculite from the surface of the water, and allow the suspension to settle for 60 minutes. After this period of time, all amphibole fibers thicker than approximately 3  $\mu\text{m}$  will have settled to the bottom of the beaker. Using a pump or syphon, transfer the supernatant liquid to a second beaker. Using ethanol, wash the sediment from the first beaker into a glass petri-dish and dry the sediment by placing the petri-dish on a slide warmer at a temperature of approximately 60°C. Use of an oven for drying the sediment is not recommended, because of the hazards associated with evaporation of ethanol in a closed environment. Transfer the sediment to a pre-weighed dish, and weigh the dish to obtain the weight of the sediment. Figure 10 shows an example of sediment after the water sedimentation procedure.

### 9.2.3 Optional Preparation of TEM Specimens From the Aqueous Suspension of Vermiculite

If amphibole asbestos is detected in the centrifugate, it can be assumed that respirable amphibole asbestos fibers are present in the aqueous suspension, and that some would be present in airborne dust generated from the vermiculite. If amphibole asbestos is not detected in the centrifugate, there is still a possibility that fine amphibole asbestos fibers, too small for detection by the stereo binocular microscope or PLM, could be present. This possibility can be confirmed or discounted by examination of particles in the aqueous suspension by TEM. Prepare analytical filters by the procedure described in 9.3.4. It is beyond the scope of this document to describe the preparation of TEM specimens from membrane filters; these procedures are fully described in ISO 13794

### 9.2.4 Density Adjustment of Heavy Liquid

Prepare a heavy liquid of density 2.75 g/mL, by addition of reagent ethanol to either 1-1-2-2-tetrabromoethane or tribromomethane (bromofom). Pure 1-1-2-2-tetrabromoethane has a density of 2.96 g/mL, and tribromomethane has a density of 2.89 g/mL.

Use of a SINK-FLOAT® standard is the most convenient and rapid method for adjustment of the liquid density. Figure 11 shows a SINK-FLOAT standard. This device is a short, sealed, glass tube containing weights, the overall weight of which is calibrated such that it does not sink or float in a liquid of the specified density. Determine the required volume of heavy liquid, and place approximately 90% of this volume of 1-1-2-2-tetrabromoethane or tribromomethane into a glass beaker. Place the SINK-FLOAT® standard into the beaker, and add reagent ethanol until the SINK-FLOAT® standard is suspended in the liquid without either sinking or floating, as shown in Figure 12. It is recommended to add the ethanol in small amounts, and to stir with a glass rod after each addition to ensure thorough mixing before adding further ethanol. If too much ethanol is added, the SINK-FLOAT® standard will sink, indicating that the density is lower than 2.75 g/mL. In this case, more of the heavy liquid can be added to adjust the density upwards to the correct value.

If a SINK-FLOAT® standard is not available, the density of the heavy liquid can be adjusted using a calculated addition of ethanol. Figure 13 shows the concentration of ethanol that must be present in a mixture with either of these heavy liquids in order to achieve a density of 2.75 g/mL. Before use, the density of the liquid produced by this method shall be confirmed by the density bottle method, and the density adjusted if necessary.

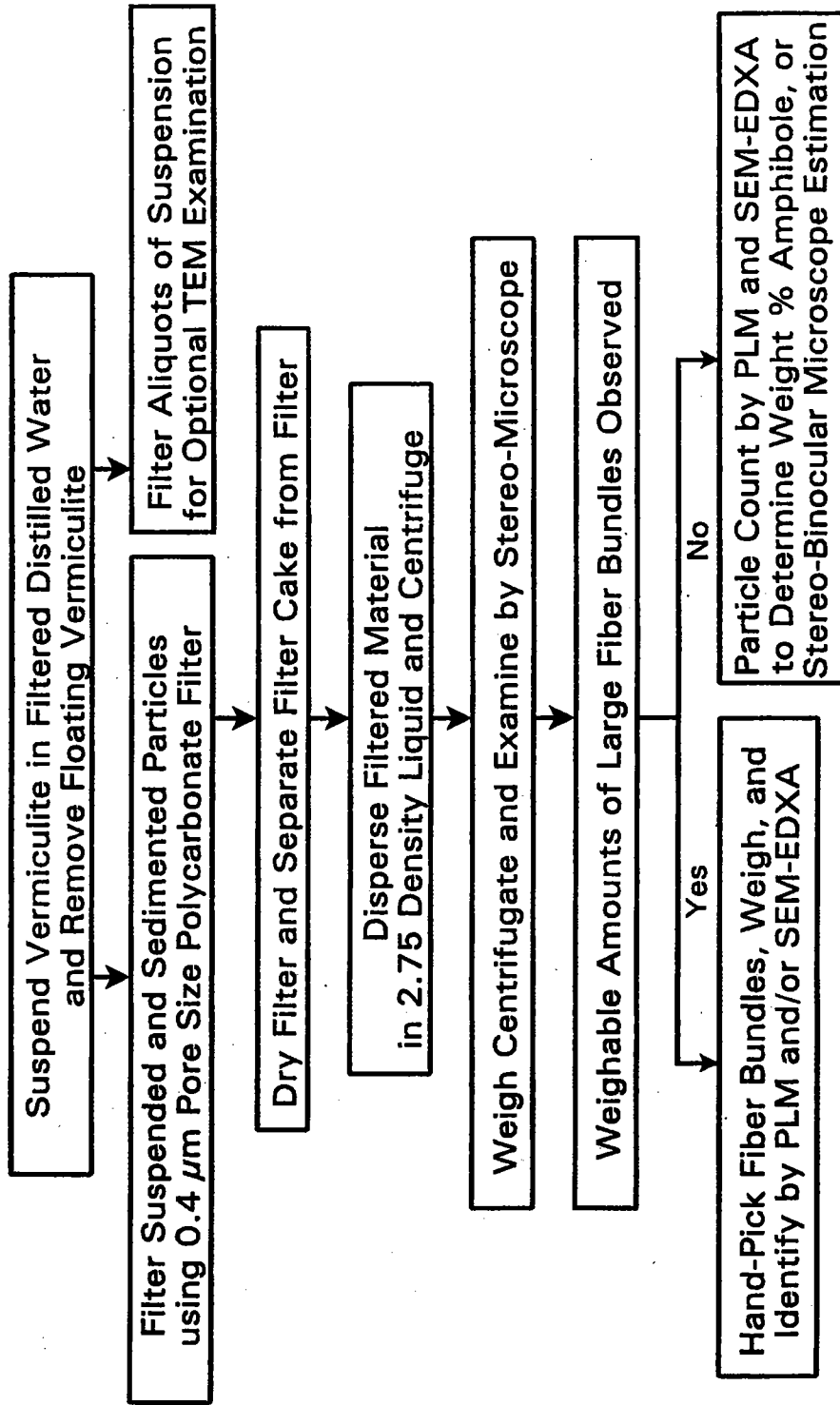
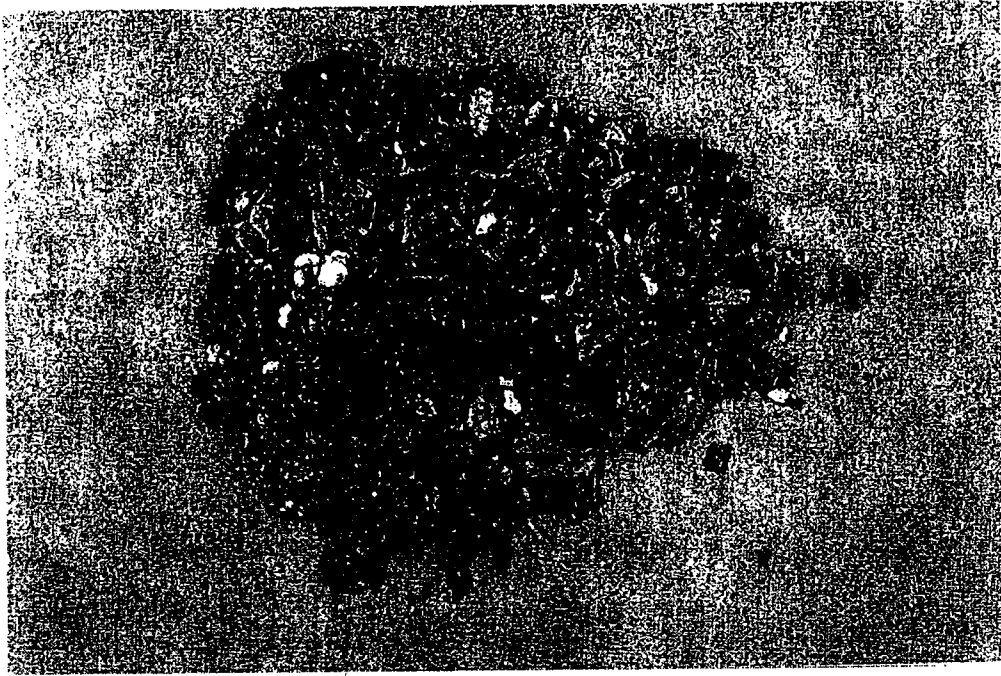

Figure 9 Flow-Chart for Rapid Screening Method for Determination of Weight Percent Asbestos in Vermiculite

**DRAFT**



**Figure 10 Example of Sediment After Water Sedimentation**

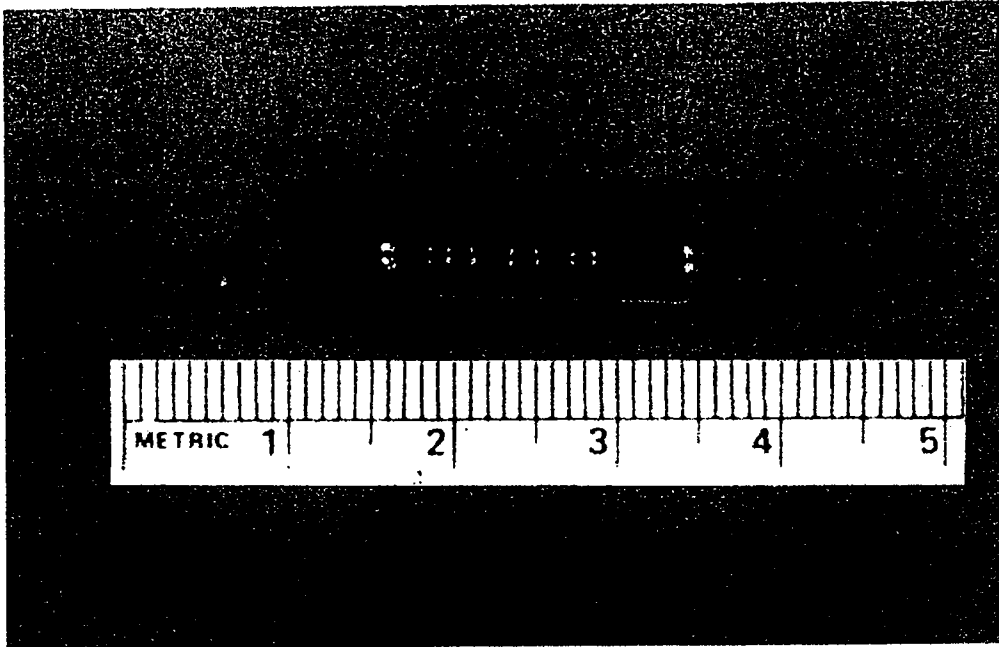

Figure 11 SINK-FLOAT® Standard For Adjustment of Liquid Density



Figure 12 Position of SINK-FLOAT® at Liquid Density of 2.75 g/mL

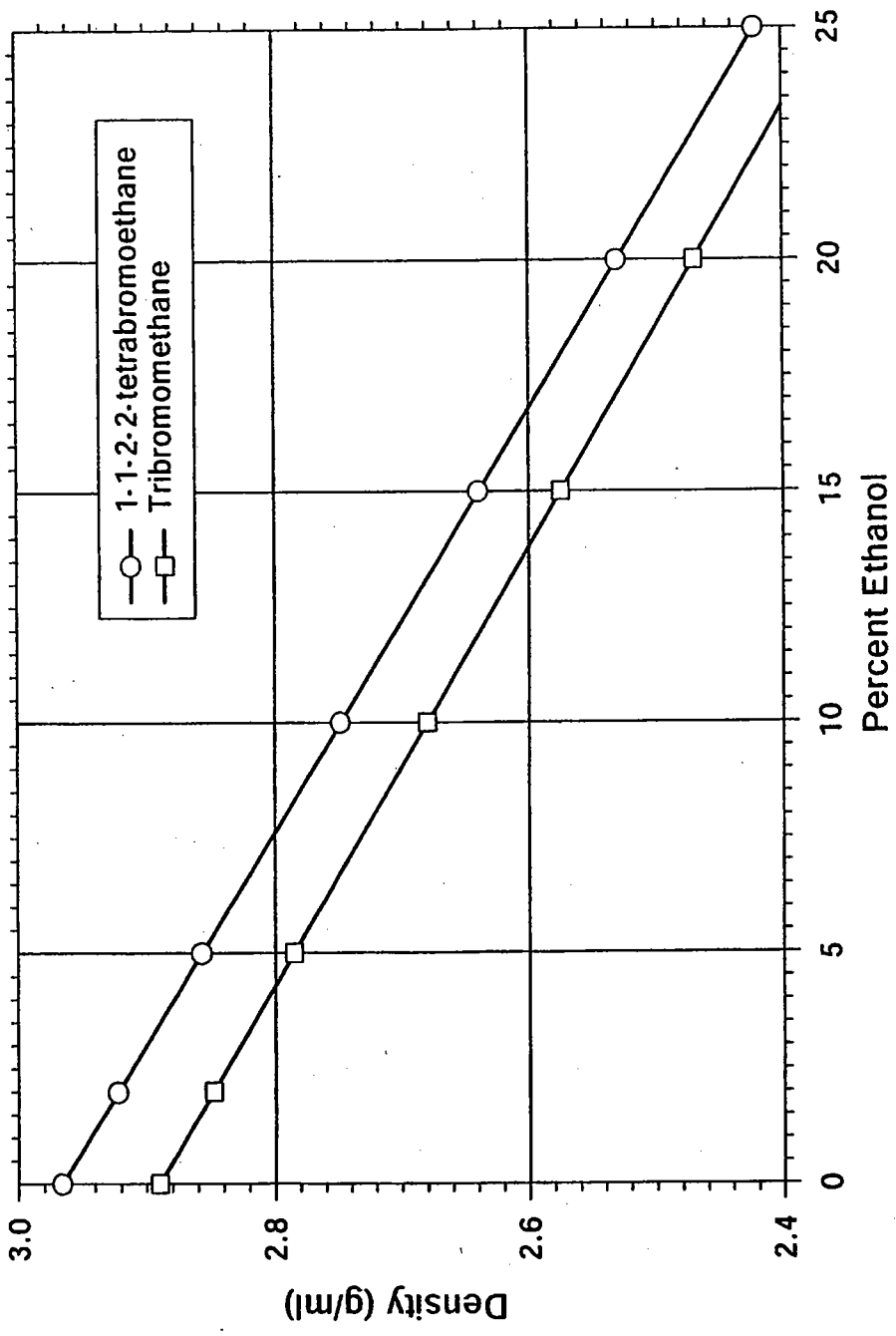

Figure 13 Volume Percent Ethanol Required for Adjustment of Heavy Liquid Density



### 9.2.5 Separation of Amphibole Fragments by Centrifugation in a Heavy Liquid

If possible, it is preferable to perform the heavy liquid separation on the entire weight of sediment from the water sedimentation. Using 15 mL centrifuge tubes, it may be necessary to divide the sediment into more than one centrifuge tube. It is recommended that no more than approximately 3-4 cm depth of sediment be processed in each 15 mL centrifuge tube. Add the density-adjusted heavy liquid to each of the centrifuge tubes until the level is approximately 0.5 cm from the top of the tube. Place the centrifuge tubes into the head of the centrifuge, balancing the head with one or more tubes containing heavy liquid if necessary. The dimensions and rotation speed of the centrifuge determine the centrifugation time necessary. The time required for sedimentation of particles can be calculated from the formula:

$$t = \frac{18 \cdot 10^8 \cdot \eta}{60 \cdot (a - b) \cdot \omega^2 \cdot d^2} \cdot \ln(R/S)$$

- Where:
- t = the time in minutes for particles of diameter d to sediment
  - $\eta$  = the coefficient of viscosity of the heavy liquid in poise
  - a = the density of the particle in g/cc
  - b = the density of the heavy liquid
  - $\omega$  = the angular velocity of the centrifuge in radians/second
  - d = the diameter of the particle in micrometers
  - R = the outer radius of the centrifuge
  - S = the inner radius of the centrifuge

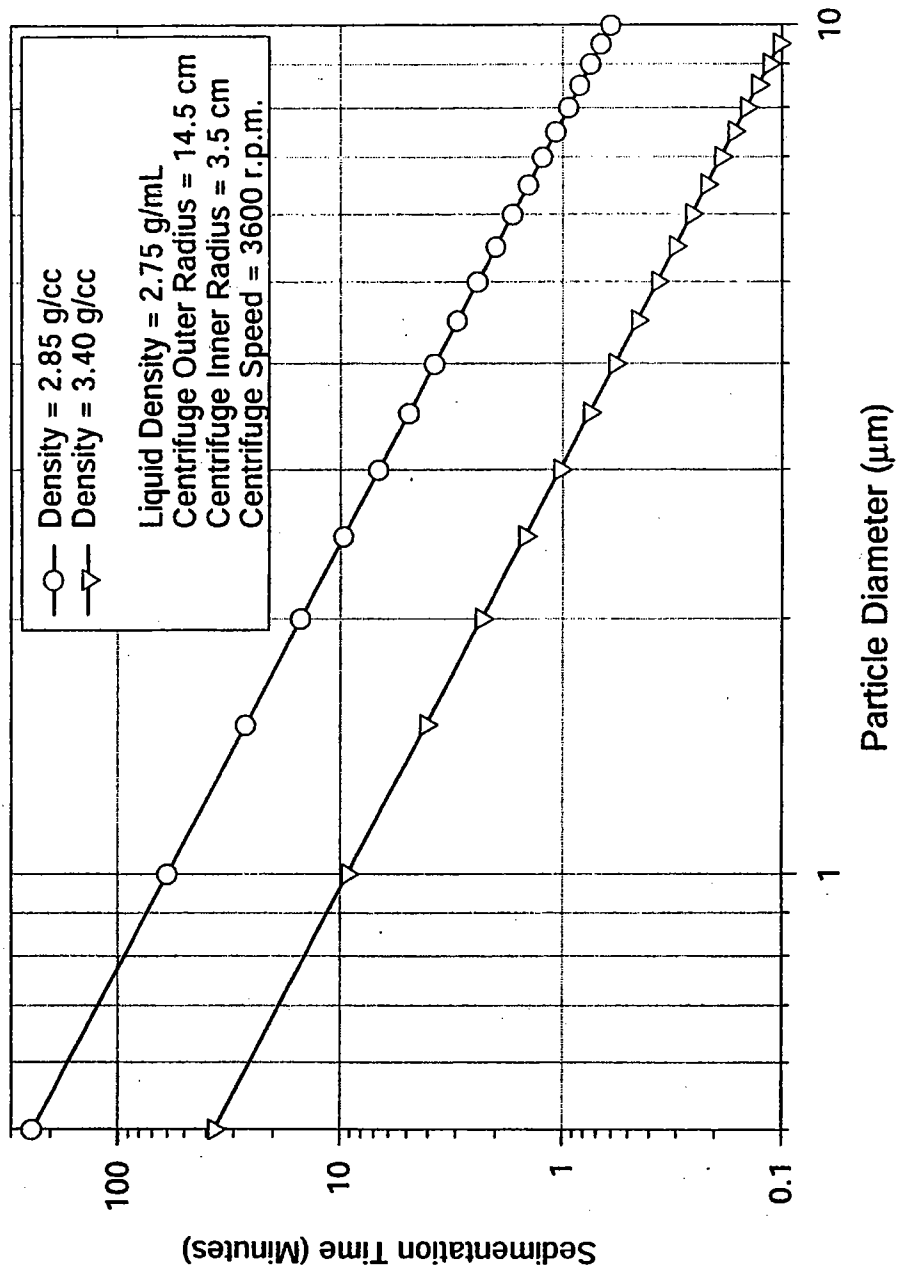
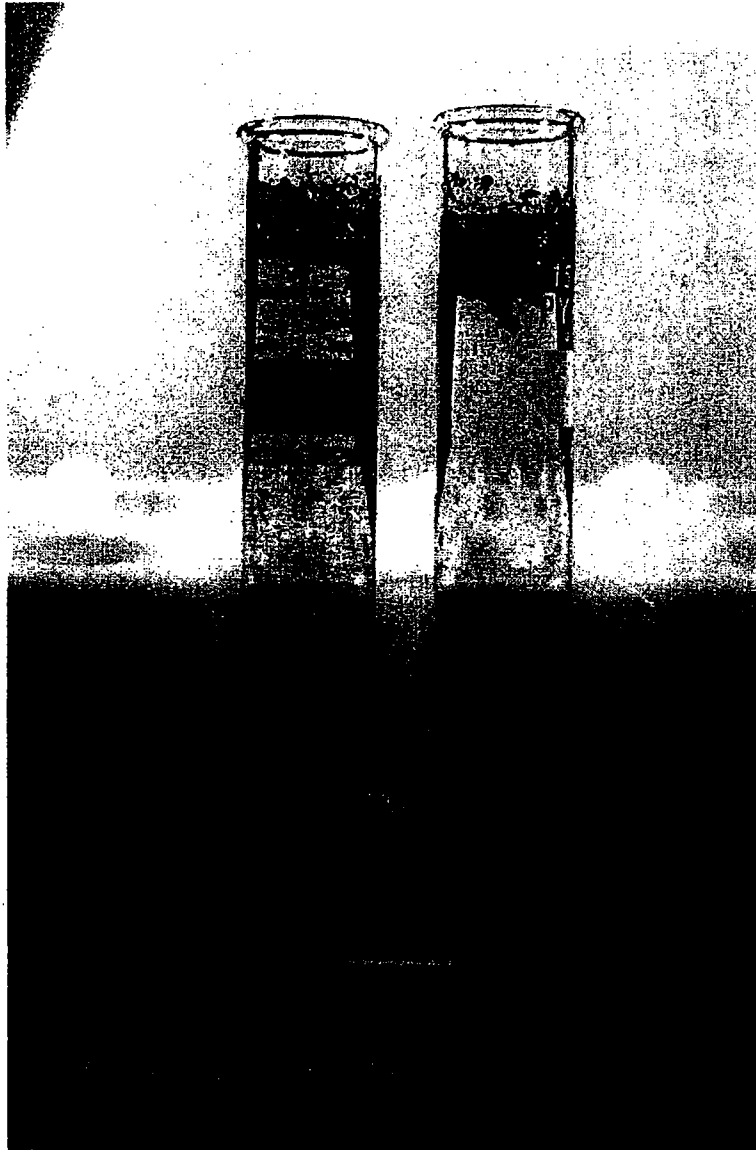

Figure 14 Example of Sedimentation Times for Particles Centrifuged in Liquid of Density 2.75

Figure 14 shows an example of times for sedimentation, using a liquid of density 2.75 g/mL, and a typical bench-top centrifuge. The centrifuge parameters used in Figure 13 are 3600 revolutions per minute, with an outer radius of 14.5 cm and an inner radius of 3.5 cm.



**Figure 15 Example of Centrifuge Tubes After Centrifugation**

With the example centrifuge, centrifugation for 10 minutes ensures that all amphibole particles larger than approximately 3  $\mu\text{m}$  will have sedimented. During centrifugation, the residue separates into a sedimented fraction (centrifugate) and a floating fraction, with very little material remaining suspended. Figure 15 shows an example of centrifuge tubes after centrifugation of the sediment from water suspension.

The next step in the analysis is to remove the floating and suspended fractions, leaving a clean centrifuge tube from which the centrifugate can be washed out. Using a small spatula, remove as much of the floating material as possible, particularly any large particles, as shown in Figure 16. Discard this material. The rest of the floating material and any particles remaining suspended in the heavy liquid is removed using a suction tube. Set up an Erlenmeyer flask as shown in Figure 17. Turn on the water aspirator, and lower the thinned polyethylene tube into the centrifuge tube as shown in Figure 18. Aspirate all of the floating material first, and then lower the polyethylene tube to remove nearly all of the supernatant liquid, avoiding any disturbance of the centrifugate at the bottom of the tube. Around the inside of the top of the centrifuge tube, some of the floating material will remain. This must be removed carefully using paper towel, in order to avoid contaminating the centrifugate with the floating material. Wrap a strip of paper towel, approximately 5 cm in width and 20 cm long, around the end of a small spatula. Holding the centrifuge tube almost horizontal so that residual floating material does not accidentally fall into the tube while it is being removed, insert the end of the spatula with the rolled paper towel into the centrifuge tube, and wipe around the inside with an upwards motion as shown in Figure 19. As the paper towel collects material, tear off a portion to expose clean paper, and continue the action of removing all of the floating material from the inside of the centrifuge tube. When all of the floating material has been removed, it is necessary to wash the centrifugate several times with ethanol in order to remove all traces of the heavy liquid. Fill the centrifuge tube with ethanol from a wash-bottle. Aim the stream of the wash-bottle at the base of the centrifuge tube as shown in Figure 20, in order to disturb and disperse the cake of particulate. Repeat this procedure with any other centrifuge tubes used for sample processing.

Pour out the heavy liquid in the tubes that were used for balancing the centrifuge, and this clean heavy liquid may be re-used. Fill these centrifuge tubes with ethanol for use in balancing the centrifuge during washing of the centrifugates

Centrifuge the tubes for 3 minutes to allow the particulate to sediment. Set up a second Erlenmeyer flask suction tube system. Turn on the water aspirator, and lower the thinned polyethylene tube into the centrifuge tube. Aspirate all of ethanol, taking care not to disturb the centrifugate at the bottom of the tube.

**DRAFT**



**Figure 16 Removal of Large Floating Particles Using Spatula**

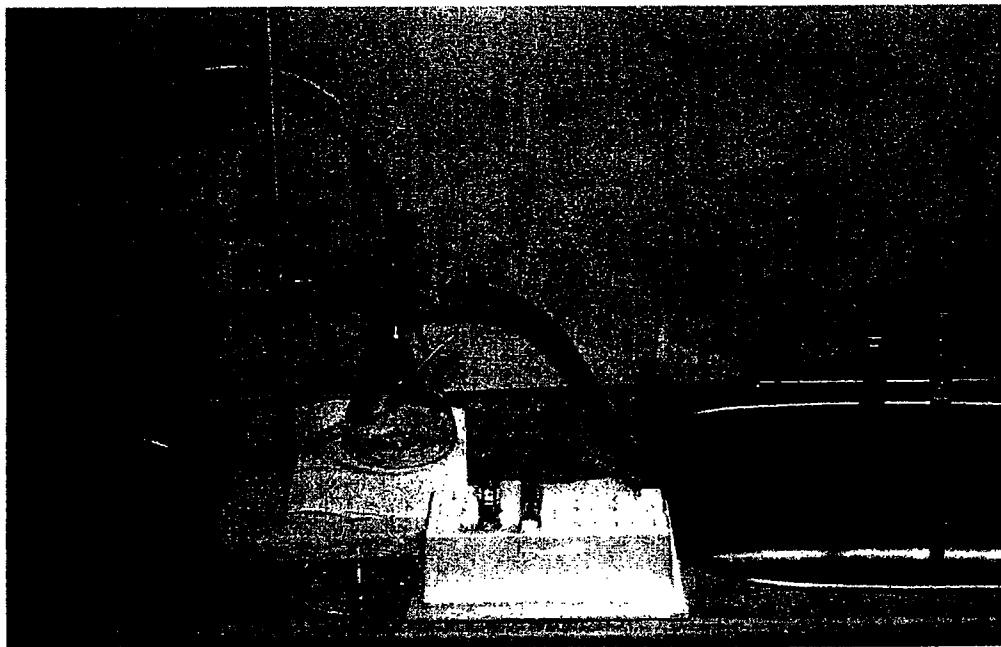

**Figure 17 Example of Suction Device to Aspirate Liquid From Centrifuge Tubes**



**Figure 18 Removal of Floating Particles and Liquid Using Aspirator**

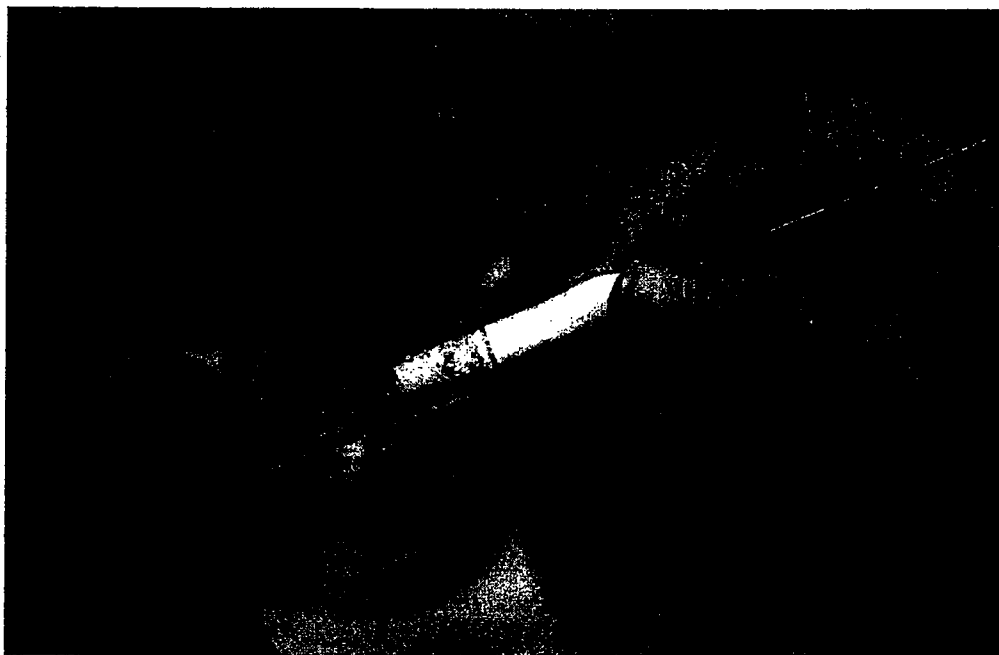

**Figure 19 Removal of Residual Floating Material From Inside of Centrifuge Tube Using Strips of Paper Towel**

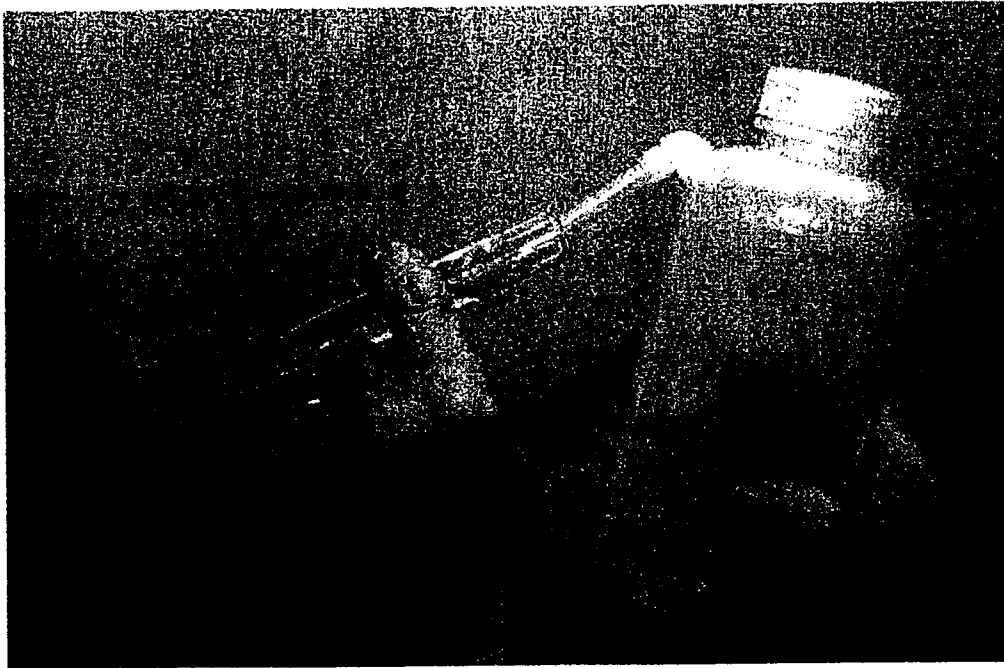

**Figure 20 Washing of Centrifugate With Ethanol**

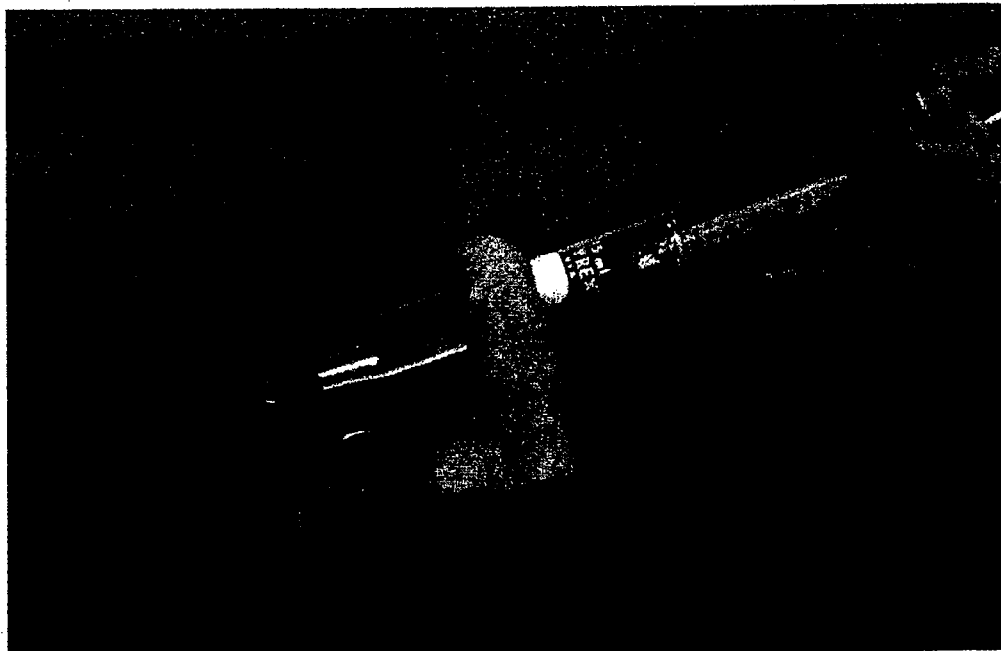

**Figure 21 Removal of Ethanol Washings Using Aspirator Tube**

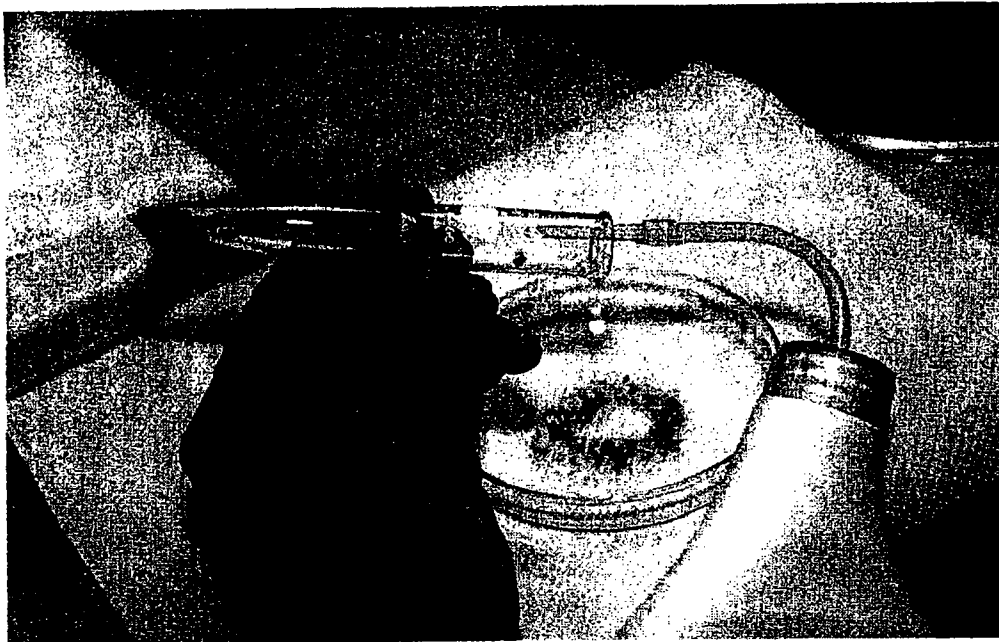

**Figure 22 Rinsing of Centrifugate from Centrifuge Tube Using Ethanol**

Repeat this ethanol washing procedure two more times. Hold the centrifuge tube inverted at an angle of approximately  $45^\circ$  over a pre-weighed, 47 mm diameter, plastic petri-dish. Using the wash-bottle with ethanol, aim the jet at the bottom of the centrifuge tube as shown in Figure 22 and wash all of the centrifugate from the tube to the petri-dish. If more than one centrifuge tube was used because the sample size was large, combine all centrifugates into the one petri-dish. During combination of centrifugates, it may be necessary to decant some of the ethanol from the petri-dish in order to avoid overflow. Place the petri-dish on the slide warmer to evaporate the ethanol. After the centrifugate is dry, weigh the dish to obtain the weight of the centrifugate.

#### **9.2.6 Stereo-Binocular Microscope Examination of the Centrifugate**

The centrifugate contains particles with densities exceeding 2.75 g/cc, which includes any amphibole particles present in the original sub-sample. There are three possible outcomes which define the extent to which further analytical work is necessary. The procedure shall be either (a), (b) or (c).

- (a) If the sample originated from Libby, Montana, the centrifugate will contain a major proportion of large fiber bundles that are gray-green in



color, and are easily visible under the stereo-binocular microscope at magnifications up to 40. If a sub-sample of sufficient size was used, numerous fiber bundles should be present in the centrifugate, as shown in Figure 23. The analyst will generally have no difficulty recognizing these fiber bundles. To quantify the fiber bundles, the analyst must determine whether the more efficient approach is to pick the fiber bundles from the centrifugate for weighing, or to remove non-asbestos particles from the centrifugate and weigh the balance of the material. The fiber bundles picked from such a centrifugate are shown in Figure 24. After the fiber bundles have been weighed, representative bundles shall be selected for identification by either PLM, SEM or TEM. The morphology, color and optical properties of the amphibole asbestos fibers in vermiculite originating from Libby are characteristic, and with experience, the analyst need go no further than mounting representative fiber bundles in a high dispersion liquid of refractive index 1.630, in which the very fine fibers exhibit dispersion staining colors of magenta to gold (parallel) and blue (perpendicular). Representative fiber bundles may be examined by SEM or TEM, and the EDXA spectra obtained may be used as the basis for identification.

- (b) If the sample originated from a mine other than Libby, Montana, few amphibole asbestos fiber bundles, if any, may be observed in the centrifugate during the stereo-binocular microscope examination. However, the centrifugate may contain a large proportion of non-asbestiform amphibole fragments. These fragments are not asbestos. Non-asbestos amphibole fragments are recognized by cleavage planes parallel to the length of the crystal, intersecting at angles of approximately  $56^\circ$  and  $124^\circ$ . In well-crystallized material, these angles can be recognized by examination of the ends of elongated fragments, such as in the centrifugate from another vermiculite sample shown in Figure 25. The total amount of non-asbestiform amphibole may be estimated by hand-picking of fragments and weighing, using the same procedure as defined in (a). If required, identification and quantification of the individual non-asbestiform amphiboles present are best performed by SEM, since there is an overlap in the optical properties of amphiboles such as actinolite and hornblende, and mixtures of amphibole types may be present.
- (c) One situation that sometimes occurs is that, during the stereo-microscope examination, only a few amphibole asbestos fiber bundles may be visible in the centrifugate, along with fragments of non-asbestiform amphiboles and other minerals. In this case, it is unlikely

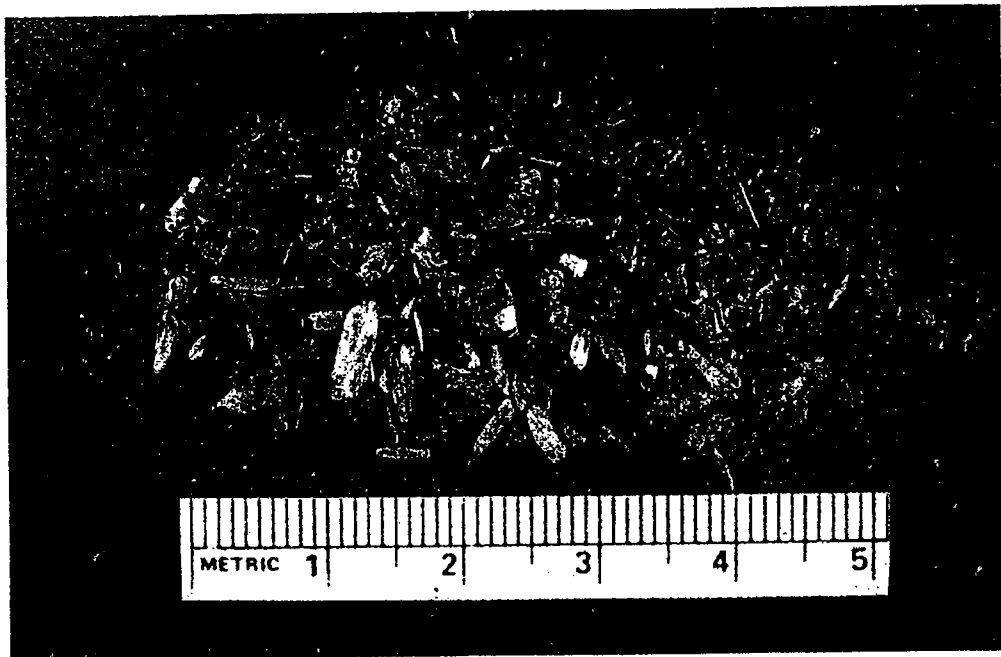

**Figure 23 Example of Centrifugate Containing Asbestos Fiber Bundles**



**Figure 24 Asbestos Fiber Bundles Hand Picked From Centrifugate**

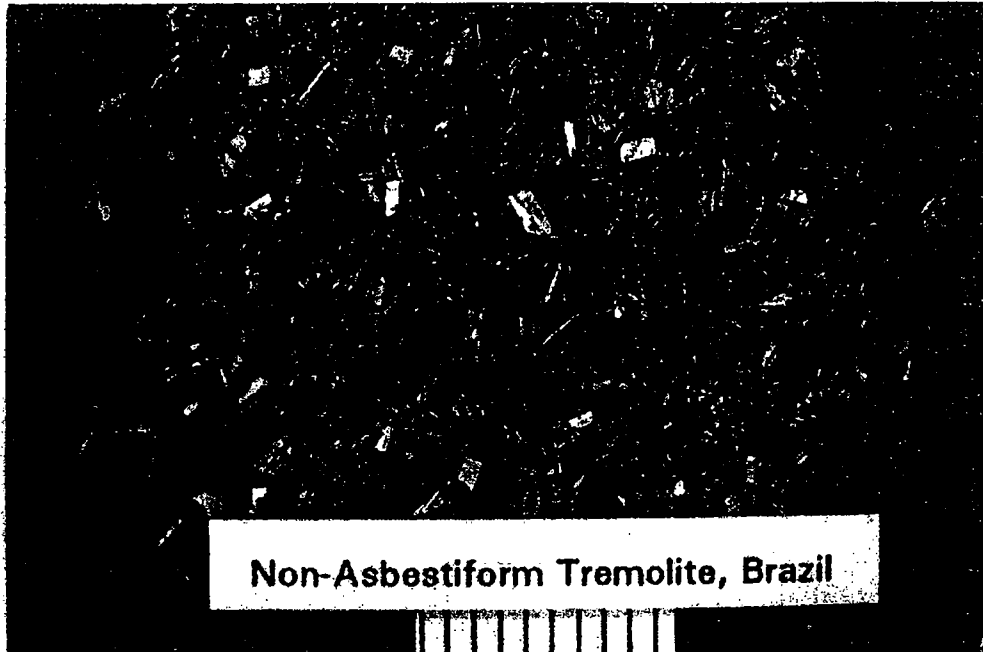

**Figure 25 Example of Non-Asbestiform Actinolite Detected in the Centrifugate from a Vermiculite Sample**

that random sampling of particles for either SEM particle counting or PLM examination would include any of these asbestos fiber bundles, and a false-negative result would be reported. If the aggregate of the amphibole asbestos fiber bundles is within the range of the chemical balance, the best approach is to pick them from the centrifugate and weigh them. The statistical validity of the calculated concentration may be limited by the low number of fiber bundles, but in general this is inconsequential since the result is close to the limit of detection.

If it is found that the aggregate weight of the fiber bundles is below the sensitivity of the balance, it is necessary to approximate their weight concentration by other methods. Two approaches to determining an estimate of the amphibole asbestos concentration are available, as described in (1) and (2).

- (1) an estimate of the upper bound of the amphibole asbestos concentration may be made by assuming the sensitivity of the balance as the weight of amphibole asbestos. In many cases, this may be sufficient for the purpose;

- (2) An approximation of the number of particles in the centrifugate may be made by estimation of the average particle size and assuming that they all have a density of 2.75. The weight percentage of any observed amphibole asbestos fiber bundles may then be approximated by a simple ratio of the number of amphibole asbestos fiber bundles to the calculated number of particles in the centrifugate. While this approach yields only an approximation of the concentration, the approximate nature of the result is generally inconsequential because the value obtained is close to the limit of detection.

In the event that a low concentration of amphibole asbestos is reported, representative fiber bundles shall be identified either by SEM or PLM. In the majority of cases, amphibole asbestos can be identified satisfactorily by PLM alone.

### **9.3 Determination of Concentration of Respirable Fibers by Transmission Electron Microscopy**

#### **9.3.1 Introduction**

In this procedure, the sample of exfoliated vermiculite is first dispersed in water, and all floating vermiculite is removed. Using a peristaltic pump, cold water is then introduced at the base of the container at a rate such that the vertical velocity in the suspension container is slightly higher than the rate of fall of the largest respirable size particle. The cold water remains at the bottom of the beaker and the suspension is displaced. The displaced suspension overflows the container and is collected in a second container. TEM specimens are then prepared from the displaced suspension, and the balance of the suspension is filtered through a pre-weighed filter. After drying, the filter is weighed to determine the total weight of respirable particles. Readily-available laboratory apparatus is used to perform this measurement. Alternative apparatus may be used, provided that the basic parameters of the measurement remain constant. Figure 26 shows a flow chart which illustrates the procedure. If the purpose is to measure only the respirable fiber concentration, and there is no interest in the weight percent measurement, the sedimentation and TEM procedure in Figure 26 should be followed.

### 9.3.2 Separation of Coarse Vermiculite

Place 800 mL of reagent water into a 1000 mL glass beaker. Using a spoon, place a portion of the exfoliated vermiculite sub-sample into the beaker, and immerse the vermiculite several times by pushing it under the surface using the spoon. Remove the floating vermiculite and discard it. Continue to wash portions of the vermiculite in this manner until all of the sub-sample has been treated. Carefully remove all floating fragments of vermiculite from the surface of the water, using a spatula. A piece of paper towel touched to the surface of the water has been found useful in removing the final traces of floating vermiculite.

### 9.3.3 Separation of Respirable Fibers by Displacement Sedimentation

After all of the floating vermiculite has been removed, make the suspension up to a volume of 1 liter using reagent water at room temperature or several degrees above room temperature. Place the beaker into a calibrated ultrasonic bath for 2 minutes. Remove the beaker from the ultrasonic bath, and mix the contents by air bubbling using filtered air. Attach the polyethylene tube to the beaker as illustrated in Figure 27, and connect it to the peristaltic pump set at a suitable volume flow rate to produce the correct upward displacement velocity. Figure 28 shows the falling speeds in water of specific size particles in the density range exhibited by amphiboles. Respirable particles of aerodynamic diameter  $10\ \mu\text{m}$ , with a density of 3.4 (the maximum density for the amphibole asbestos varieties) have a physical diameter of approximately  $5.42\ \mu\text{m}$ . Particles of this diameter have a falling speed in water of  $3.82 \times 10^{-3}\ \text{cm/s}$ , and this upward velocity must be established during the displacement sedimentation. Attach the cold water supply to the peristaltic pump, and activate the pump. Depending on the size of the container used for the vermiculite suspension, the displacement process may take up to 1 hour for completion. The water supply to the peristaltic pump must remain cold for this period. One way of ensuring this is to cool the water supply container by immersion in a larger container containing ice cubes. Progress of the displacement process may be monitored visually if the cold water supply is colored. Normal red food color has been found satisfactory as an indicator.

#### 9.3.4 Preparation of TEM Specimens From Displaced Suspension

After all of the vermiculite suspension has been displaced, pour the displaced suspension into a 1 liter glass beaker, and homogenize the suspension by agitation using filtered air. Filtration of the aqueous suspension is a very critical procedure because it is important to obtain uniform deposits of particulate on the analytical filters. The following procedure shall be used.

- (a) Set up the filtration system and connect to a vacuum source;
- (b) add freshly distilled water to the filtration unit base component until there is a raised meniscus;
- (c) place a 5  $\mu\text{m}$  pore size cellulose ester filter on to the water meniscus. The filter will centralize. Apply the vacuum very briefly in order to bring the filter into contact with the base component;
- (d) add freshly distilled water to the top of the cellulose ester filter, and place the analytical filter (either a 0.2  $\mu\text{m}$  maximum pore size capillary-pore polycarbonate filter or a 0.22  $\mu\text{m}$  maximum pore size cellulose ester filter) on to the water surface. Apply the vacuum very briefly again in order to bring both filters into contact with the base component;
- (e) install the filtration reservoir and clamp the assembly together.
- (f) Before filtering the aqueous suspensions, prepare a funnel blank by filtration of 40 mL of freshly-distilled water. This sample is a control to ensure that the filtration equipment is clean and the reagent water is not contaminated by fibers.

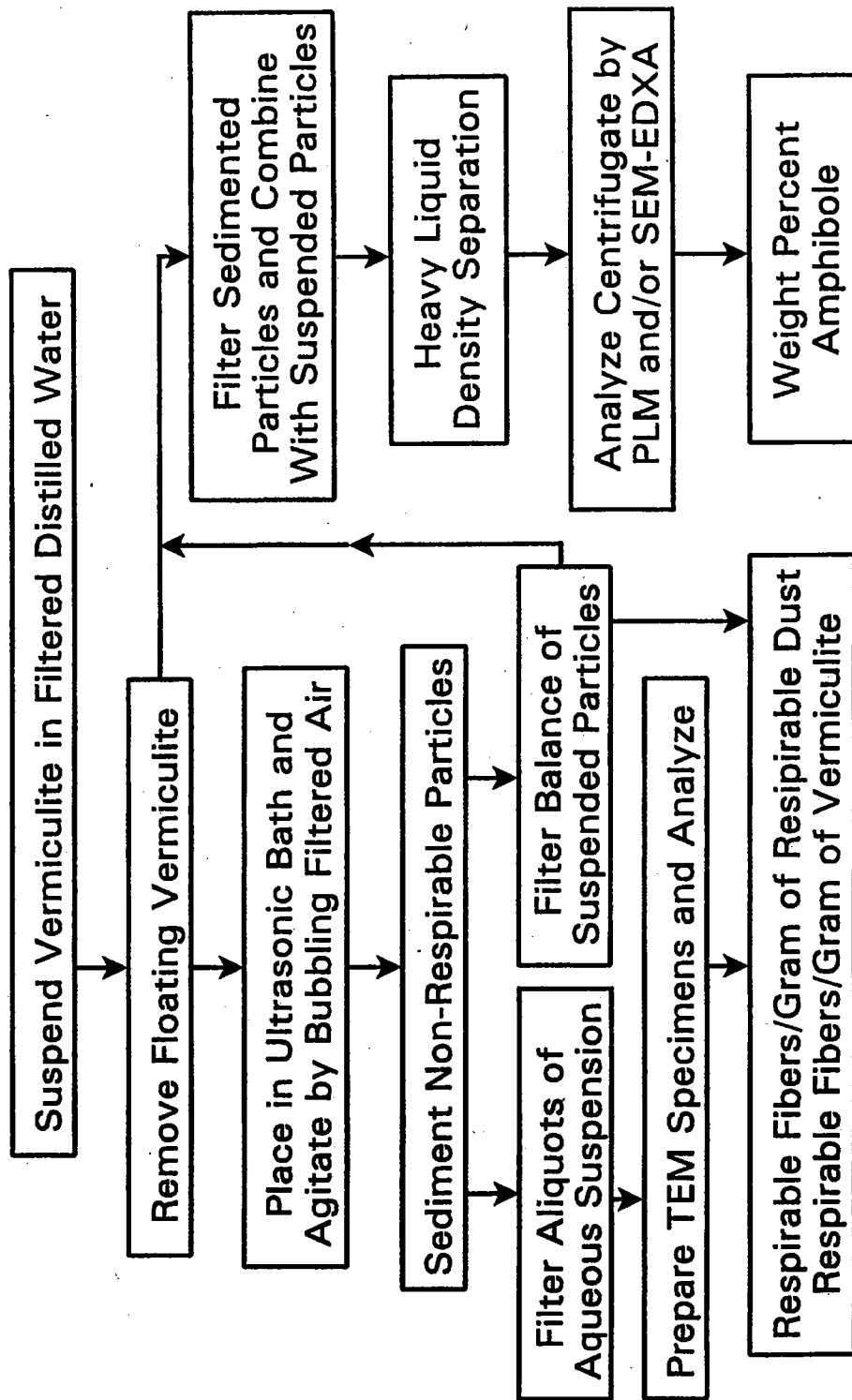

Figure 26 Summary of Analytical Method for Determination of Asbestos in Vermiculite

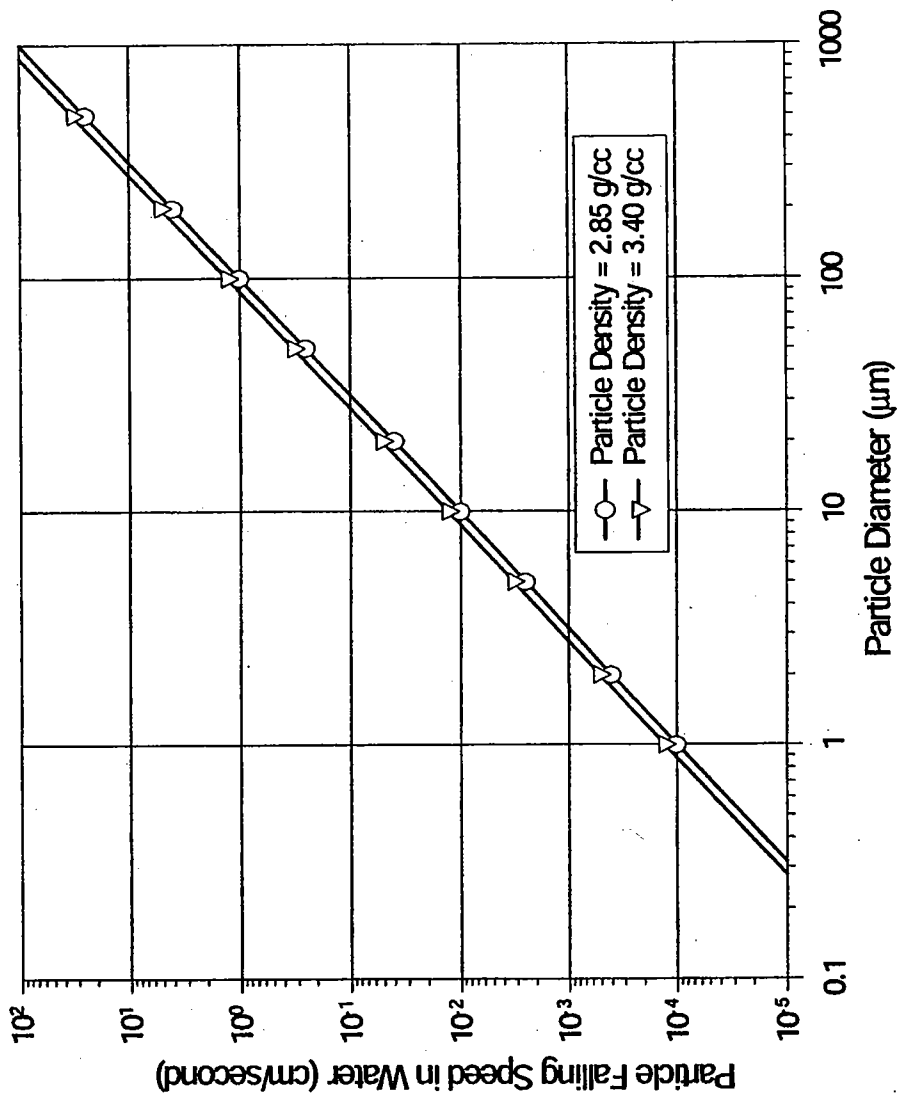
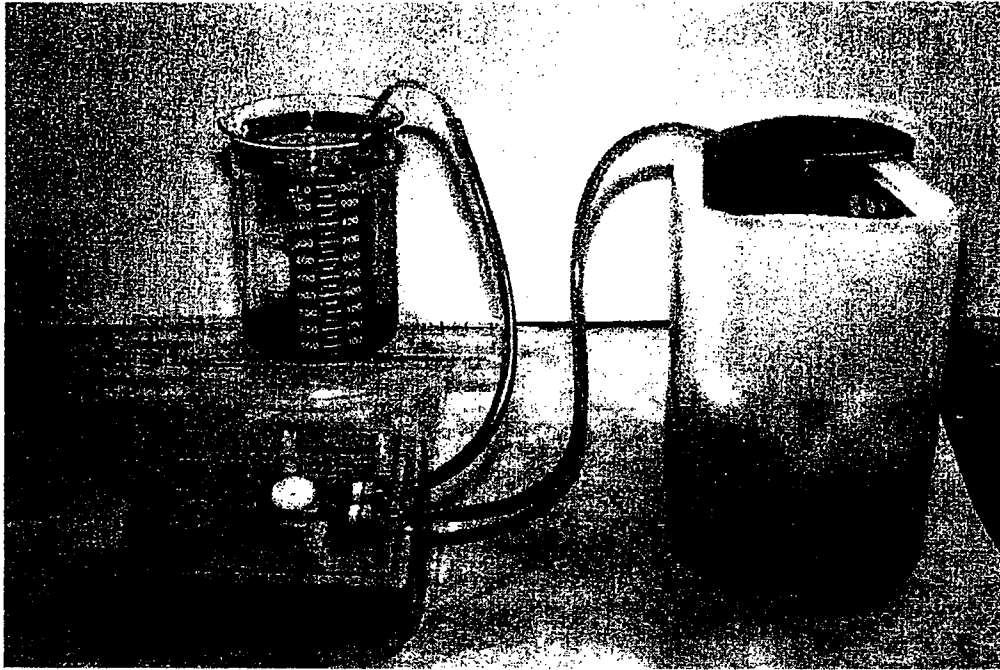

Figure 27 Falling Speeds of Particles in Water



**DRAFT**



**Figure 28 Apparatus for Displacement Sedimentation Procedure**

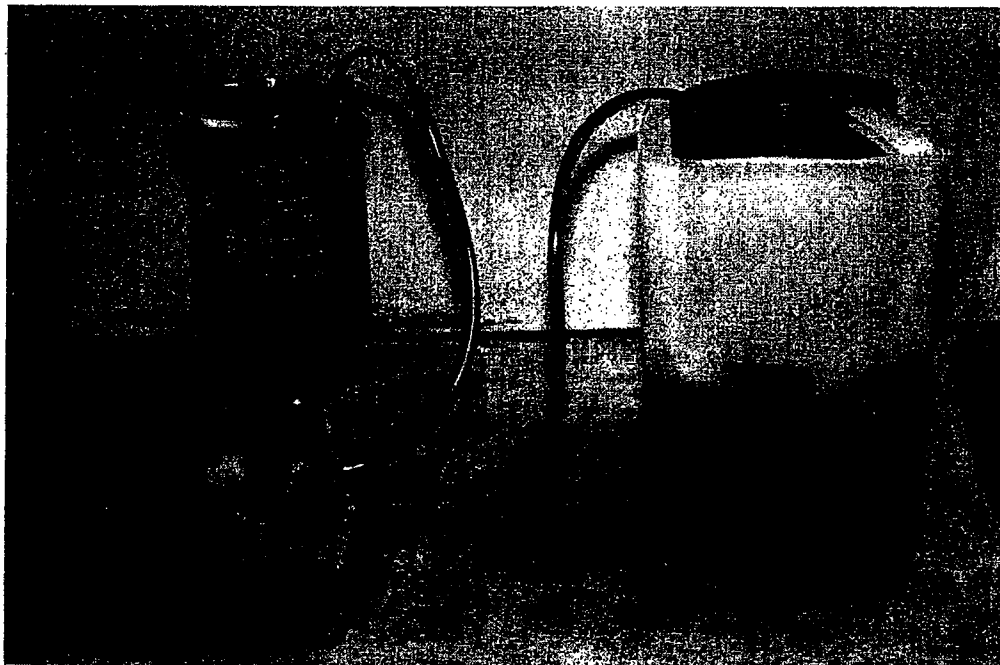

**Figure 29 Displacement Sedimentation at Approximately 40% Completion**

- (g) The volume of the aqueous suspension to be filtered depends on either the particulate concentration or the asbestos fiber concentration. The volume of the aqueous suspension required to produce an analytical filter with a suitable particulate or fiber loading for analysis often cannot be predicted, and it is usually necessary to prepare several analytical filters corresponding to filtration of different aliquots. The number of grid openings on the TEM specimens that require examination in order to achieve a particular analytical sensitivity are shown in Table 2.

Table 2 - Examples of the minimum number of grid openings of TEM specimens required to be examined to achieve a particular analytical sensitivity and limit of detection

Analytical sensitivity (10 <sup>6</sup> Fibers/g)	Limit of detection (10 <sup>6</sup> Fibers/g)	Volume of Suspension Filtered (mL)				
		0.01	0.03	0.1	0.3	1
0.1	0.3	551	184	56	19	6
0.2	0.6	276	92	28	10	4
0.3	0.9	184	62	19	7	4
0.4	1.2	138	46	14	5	4
0.5	1.5	111	37	12	4	4
0.7	2.1	79	27	8	4	4
1	3	56	19	6	4	4
2	6	28	10	4	4	4
3	9	19	7	4	4	4
4	12	14	5	4	4	4
5	15	12	4	4	4	4
7	21	8	4	4	4	4
10	30	6	4	4	4	4

**NOTES**

In Table 1, it is assumed that the initial sample weight was 50 grams, the volume of water used to disperse the sample is 1 liter, the active area of the analytical filter is 199 mm<sup>2</sup>, and the TEM grid openings are square with a linear dimension of 85 μm. The limit of detection is defined as the upper 95% confidence limit of the Poisson distribution for a count of zero structures. In the absence of background, this is equal to 2.99 times the analytical sensitivity. Non-zero backgrounds observed during analysis of blank filters will degrade the limit of detection.

- (h) The aqueous suspensions are generally not stable; it is therefore necessary to prepare all analytical filters immediately. Uniform deposits of particulate on the analytical filters cannot be assured if liquid volumes smaller than 5 mL are filtered using filtration systems of 199 mm<sup>2</sup> active area; accordingly, where it is required to filter volumes smaller than 5 mL, the aliquot shall be diluted with freshly-distilled and filtered water to a volume exceeding 5 mL.
- (i) Pour the aliquot of the suspension into the filtration reservoir, and apply the vacuum. If the volume of the aliquot is larger than the capacity of the filtration reservoir, do not allow the level of liquid in the reservoir to fall below 5 cm depth before the remaining volume is added. Failure to observe this precaution may result in disturbance of the filtered particulate and non-uniform deposition.
- (j) With the vacuum still applied, unclamp the filtration assembly and remove the filtration reservoir. Using clean tweezers, remove the analytical filter and transfer it to a petri-dish. Allow the filter to dry before placing the cover on the petri-dish.
- (k) For the beaker blank, prepare only one analytical filter by filtration of the entire 40 mL suspension.
- (l) After filtration of the aliquots for preparation of TEM specimens, filter the balance of the suspension through a pre-weighed, 0.4 µm pore size polycarbonate filter. Dry the filter with the particulate deposit and re-weigh to determine the weight of respirable particulate material and fibers. This measurement is needed in order to express the concentration of respirable fibers relative to the weight of total respirable particulate material.

#### NOTES

It is recommended to prepare several analytical filters from the suspension. If the particulate or fiber concentration is thought to be such that it is required to filter an aliquot of lower volume than 1 mL, use a dilution procedure in which 1 mL of the original suspension is transferred to a clean beaker and diluted with freshly-distilled water to a total volume of 100 mL. After stirring to ensure complete mixing, aliquots of 1 mL, 3 mL, 10 mL and 30 mL from this diluted suspension can then be filtered, corresponding to volumes of 0.01 mL, 0.03 mL, 0.1 mL and 0.3 mL of the original suspension. From the original dispersion, volumes of 1 mL and 3 mL can also be filtered, giving 6 analytical filters with a concentration range of a factor of 300. The requirement for washing of the filtration apparatus is minimized if the aliquots are filtered in order of increasing concentration.

It is beyond the scope of this method to provide detailed instructions for preparation of TEM specimens from membrane filters; these instructions are published in ISO 13794. It is recommended that aliquots of the aqueous suspension of vermiculite be filtered using the method specified in ISO 13794. If polycarbonate filters are used, they shall be cleaned to remove the asbestos contamination frequently present on this type of filter (Chatfield, 2000). Prepare TEM specimens from the filters using the methods specified in ISO 13794.

#### **9.3.5 Examination of TEM Specimens**

Criteria for examination of TEM specimens are specified in ISO 10312 and ISO 13794. For the purpose of deriving risk estimates, only asbestos structures longer than 5  $\mu\text{m}$  need be considered. The above ISO Standards specify that a magnification of approximately 10,000 is sufficient for determination of the concentration of asbestos structures longer than 5  $\mu\text{m}$ . Identify amphiboles according to the International Mineralogical Association classification (Leake, 1997)

#### **9.4 Combined Procedure**

If both the concentration of respirable fibers and the weight percent of amphibole asbestos are required, follow the full flow chart as specified in Figure 25, along with the more detailed instructions for determination of the individual parameters.

### **10 DATA REPORTING**

#### **10.1 Rapid Screening Analysis to Determine Weight Percent of Amphibole Asbestos**

In the test report, all relevant measurements shall be reported, including:

- (a) the initial weight of the sub-sample;
- (b) the weight loss on drying (if applicable);
- (c) the weight loss on ashing (if applicable);
- (d) the weight of sediment after water sedimentation;
- (e) the weight of centrifugate after centrifugation;
- (f) the manner by which asbestos in the centrifugate was quantified; and one of the following:

- (1) the weight of hand-picked asbestos;
  - (2) the number of centrifugate particles and the number of asbestos fiber bundles;
  - (3) the assumed sensitivity of the chemical balance;
- (g) the weight percent of amphibole asbestos in the original sub-sample, calculated by procedures (1), (2) or (3).

## 10.2 Concentration of Respirable Fibers

Report all of the analytical parameters, and from these parameters calculate the analytical sensitivity  $S$ , in structures/gram, using the formula:

$$S = \frac{(A_a \cdot V_d)}{(k \cdot A_g \cdot V_f \cdot M_s)}$$

where:

$S$	=	Required analytical sensitivity in structures/gram
$A_a$	=	Active area of analytical filter in $\text{mm}^2$
$V_d$	=	Volume of water in mL used for dispersal of sample
$k$	=	Number of grid openings examined
$A_g$	=	Area of TEM specimen grid opening in $\text{mm}^2$
$V_f$	=	Volume of aqueous dispersion filtered in mL
$W_s$	=	Weight of solid material

Report the lengths, widths and identifications of all respirable fibers detected that have compositions consistent with any asbestos varieties specified in Section 4 (Definitions). Using the calculated analytical sensitivity, report the concentration of respirable fibers per gram of original sub-sample, and per gram of total respirable particulate material. Also report the 95% confidence interval of these measurements, and the numbers of fibers on which the measurements are based.

## **11 ACCURACY AND PRECISION**

### **11.1 Rapid Screening Analysis to Determine Weight Percent of Amphibole Asbestos**

The accuracy of this analysis is limited only by transfer losses during processing, and by the sensitivity of the laboratory balance. The precision is limited by the initial size of the sub-sample, and the statistical effects of large asbestos fiber bundles when there are only small numbers present, or when one or more asbestos fiber bundles represent a large proportion of the weight of asbestos detected.

### **11.2 Concentration of Respirable Fibers**

There is no independent method to establish the accuracy of measurements of the concentration of respirable fibers. The precision of measurements, for measurements based on water suspensions of fibers, is usually limited by the Poisson distribution if filtrations are performed using the specified procedures. Accordingly, the precision can be improved by examination of greater areas of the TEM specimens in order to collect data on larger numbers of fibers.

## **12 REFERENCES**

**Chatfield, E.J. and Lewis, G.M. (1980):** Development and application of an analytical technique for measurement of asbestos fibers in vermiculite. In: Scanning Electron Microscopy/1980/I, (O. Johari, Ed.). SEM Inc., AMF O'Hare, Chicago, Illinois 60666, U.S.A.

**Chatfield, E.J. (2000):** A rapid procedure for preparation of transmission electron microscopy specimens from polycarbonate filters. ASTM STP 1342, Advances in Environmental Measurement Methods for Asbestos, Michael E. Beard and Harry L. Rook, Eds., 242-249

**International Mineralogical Association (1978):** Nomenclature of amphiboles (compiled by B.E. Leake), Canadian Mineralogist, 16:501

**International Mineralogical Association (1997):** Nomenclature of amphiboles: Report of the Subcommittee on Amphiboles of the International Mineralogical Association Commission on New Minerals and Mineral Names (compiled by B.E. Leake), Mineralogical Magazine, April 1997, Vol 61, pp 295-321

**International Organization for Standardization (1999): ISO 13794, Ambient air -  
Determination of asbestos fibres - Indirect-transfer Transmission electron  
microscopy method**

## APPENDIX A. RECOVERY OF HEAVY LIQUIDS FOR RE-USE

### A.1 Background

The heavy liquids used in this analytical method are quite expensive, and for both economic and environmental reasons they should not be discarded after use. Accordingly, a method for recovery of these liquids is required.

For use in screening analyses, it is usually sufficient to remove the larger fragments of material by filtration through a coarse Whatman paper filter, followed by pressure filtration through a 0.22  $\mu\text{m}$  porosity mixed esters of cellulose filter. Both liquids are compatible with this type of filter, but compatibility with filter unit components must be considered before such components are used. The liquid will acquire a coloration on the first use, but this does not interfere with screening analyses. If the analytical procedure includes measurement of fine fibers by transmission electron microscopy, the retention of particles by a 0.22  $\mu\text{m}$  porosity filter may be insufficient to prevent cross-contamination between samples, and for these types of analyses the heavy liquid must be purified by distillation.

### A.2 Purification of Heavy Liquids by Distillation

The boiling point of 1-1-2-2-tetrabromoethane is approximately 243.5°C, but unfortunately it decomposes at this temperature, liberating bromine. It is therefore not possible to distill this liquid at the boiling point at atmospheric pressure. If vacuum distillation equipment is available, 1-1-2-2-tetrabromoethane can be distilled at reduced atmospheric pressures. The boiling point of tribromoethane (bromoform) is approximately 150.5°C, and it can be distilled at atmospheric pressure without decomposition. Table A1 shows the vapor pressure of 1-1-2-2-tetrabromoethane and tribromoethane at various temperatures below the atmospheric pressure boiling point. Suitable distillation conditions can be selected from Table A1.

A non-boiling still is the optimum method for recovery of the heavy liquids, because this method of distillation avoids carry-over of solid particles into the distillate by the spray generated from the boiling liquid during conventional distillation. A non-boiling still can be operated at a temperature significantly below the boiling point at atmospheric pressure, but still have an acceptable distillation rate. Even with good design, the distillation rate is relatively slow, but the advantage is that the distillate is very pure and contains far fewer particles than distillates from conventional distillation. Satisfactory distillation rates are obtained at vapor pressures of 40 mm and higher.



**Table A.1 Vapor Pressure - Temperature Data for 1-1-2-2-Tetrabromoethane and Tribromomethane (Bromoform)**

Vapor Pressure, mm	Temperature, °C	
	1-1-2-2-Tetrabromoethane	Tribromomethane
1	65	(Solid)
10	110	34
40	144	63.6
100	170	85.9
400	217.5	127.9
760	243.5	150.5

A suitable non-boiling still can be constructed very simply, and a diagram of one design is illustrated in Figure A1. Liquid in the base of the container is heated by an annular heater attached to the base. The condenser consists of a 250 mL glass flask through which there is a circulation of cold water. Vapor from the heavy liquid condenses on the outer surface of the condenser, and the condensed liquid falls into a glass funnel which passes through the base of the container. The power supply to the heater is controlled by a light dimmer. A simple still of this design can be operated at a temperature of approximately 150°C, and an example of the construction is shown in Figure A2.

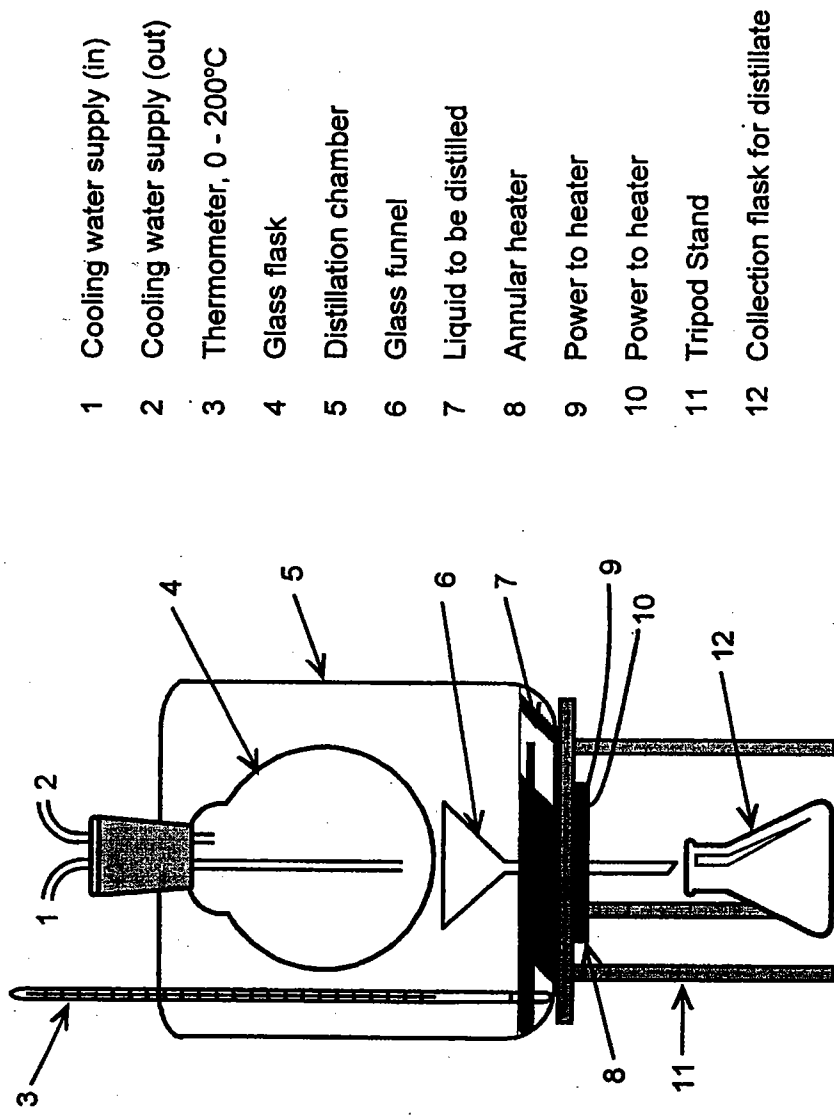
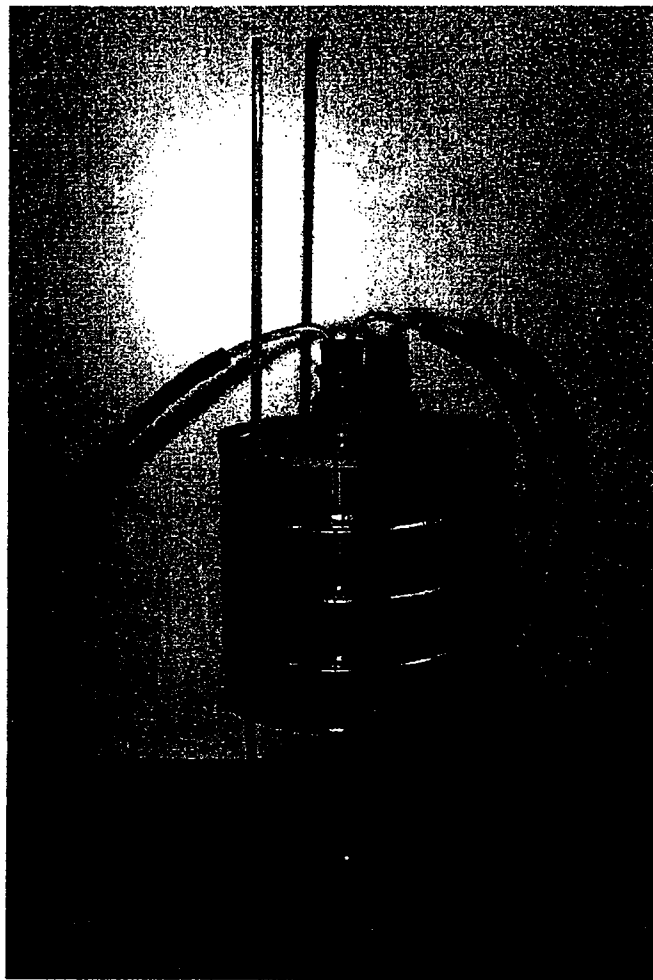

Figure A1 Example of Design of Non-Boiling Still for Recovery of Heavy Liquids

**DRAFT**



**Figure A2 Example of Non-Boiling Still For Recovery of Heavy Liquids**