

**Arsenic Removal from Drinking Water by Adsorptive Media  
EPA Demonstration Project at Rollinsford, NH  
Six-Month Evaluation Report**

by

**Jeff Oxenham  
Abraham S.C. Chen  
Lili Wang**

**Battelle  
Columbus, OH 43201-2693**

**Contract No. 68-C-00-185  
Task Order No. 0019**

for

**Thomas J. Sorg  
Task Order Manager**

**Water Supply and Water Resources Division  
National Risk Management Research Laboratory  
Cincinnati, Ohio 45268**

**National Risk Management Research Laboratory  
Office of Research and Development  
U.S. Environmental Protection Agency  
Cincinnati, Ohio 45268**

## **DISCLAIMER**

The work reported in this document was funded by the United States Environmental Protection Agency (EPA) under Task Order 0019 of Contract 68-C-00-185 to Battelle. It has been subjected to the Agency's peer and administrative reviews and has been approved for publication as an EPA document. Any opinions expressed in this paper are those of the author(s) and do not, necessarily, reflect the official positions and policies of the EPA. Any mention of products or trade names does not constitute recommendation for use by the EPA.

## FOREWORD

The U.S. Environmental Protection Agency (EPA) is charged by Congress with protecting the nation's land, air, and water resources. Under a mandate of national environmental laws, the Agency strives to formulate and implement actions leading to a compatible balance between human activities and the ability of natural systems to support and nurture life. To meet this mandate, EPA's research program is providing data and technical support for solving environmental problems today and building a science knowledge base necessary to manage our ecological resources wisely, understand how pollutants affect our health, and prevent or reduce environmental risks in the future.

The National Risk Management Research Laboratory (NRMRL) is the Agency's center for investigation of technological and management approaches for preventing and reducing risks from pollution that threaten human health and the environment. The focus of the Laboratory's research program is on methods and their cost-effectiveness for prevention and control of pollution to air, land, water, and sub-surface resources; protection of water quality in public water systems; remediation of contaminated sites, sediments and groundwater; prevention and control of indoor air pollution; and restoration of ecosystems. NRMRL collaborates with both public and private sector partners to foster technologies that reduce the cost of compliance and to anticipate emerging problems. NRMRL's research provides solutions to environmental problems by developing and promoting technologies that protect and improve the environment; advancing scientific and engineering information to support regulatory and policy decisions; and providing the technical support and information transfer to ensure implementation of environmental regulations and strategies at the national, state, and community levels.

This publication has been produced as part of the Laboratory's strategic long-term research plan. It is published and made available by EPA's Office of Research and Development to assist the user community and to link researchers with their clients.

Sally Gutierrez, Director  
National Risk Management Research Laboratory

## ABSTRACT

This report documents the activities performed and the results obtained from the first six months of the arsenic removal treatment technology demonstration project at the Rollinsford Water and Sewer District facility in Rollinsford, NH. The objectives of the project are to evaluate the effectiveness of AdEdge Technologies' AD-33 media in removing arsenic to meet the new arsenic maximum contaminant level (MCL) of 10 µg/L. Additionally, this project evaluates the reliability of the treatment system (Arsenic Package Unit [APU]-100), the simplicity of required system operation and maintenance (O&M) and operator's skills, and the cost-effectiveness of the technology. The project also characterizes the water in the distribution system and process residuals produced by the treatment process.

The APU-100 treatment system consisted of two 36-inch-diameter, 72-inch-tall fiberglass reinforced plastic (FRP) vessels in parallel configuration, each containing approximately 27 ft<sup>3</sup> of AD-33 media. The AD-33 media is an iron-based adsorptive media developed by Bayer AG and packaged under the name of AD-33 by AdEdge. This media is identical to Severn Trent Services' SORB 33™ media used at larger arsenic removal systems. The system was designed for a peak flowrate of 100 gallons per minute (gpm) (50 gpm to each vessel) corresponding to a design empty bed contact time (EBCT) of about 4 minutes per vessel and a hydraulic loading to each vessel of about 7 gpm/ft<sup>2</sup>.

The AdEdge treatment system began regular operation on February 9, 2004. The types of data collected included system operation, water quality (both across the treatment train and in the distribution system), process residuals, and capital and O&M costs. Through the period from February 9 to August 13, 2004, the system treated approximately 7,158,000 gallons of water or about 19,500 bed volumes. Breakthrough of total arsenic concentrations above the 10 µg/L target level was first observed during the May 25, 2004 sampling event at 12,500 bed volumes. Concentrations in the treated water were below 10 µg/L during the next sampling event on June 8, but again exceeded the target level of 10 µg/L on June 22. Based on this data, it appears that breakthrough of arsenic at concentrations above the target level occurred somewhere between 12,500 and 15,000 bed volumes (or approximately 4.5 to 5.5 million gallons of water treated). This volume represents about 15 to 20% of the vendor-estimated working capacity of AD-33 media. Prior to breakthrough, the system reduced total arsenic levels from between 28.7 and 46.3 µg/L in raw water to <10 µg/L in the treated water. The soluble arsenic concentration in the raw water included an average of 18.3 µg/L of As(III) and 14.8 µg/L of As(V). In March, 2004 total arsenic levels in the treated water were observed at concentrations of 5.5 to 7.7 µg/L, and the majority of arsenic passing through the AD-33 media was As(III). Prechlorination was added to the treatment train on March 24, 2004 and was effective at oxidizing As(III) to As(V). Following the switch to prechlorination, the average As(III) concentration in the treated water dropped to 0.6 µg/L, which was very similar to the As(III) concentration seen in untreated water sampled upstream of the adsorption system.

Total and free chlorine residuals measured before and after the adsorption vessels were similar, ranging from 0.05 to 0.40 mg/L (as Cl<sub>2</sub>) for free chlorine and 0.20 to 0.71 mg/L (as Cl<sub>2</sub>) for total chlorine before the adsorption vessels, to 0.04 to 0.05 mg/L (as Cl<sub>2</sub>) for free chlorine and 0.23 to 0.26 mg/L (as Cl<sub>2</sub>) for total chlorine after the vessels. This indicates little or no chlorine consumption by the AD-33 media.

Influent total iron concentrations ranged from 37 to 489 and averaged 156.4 µg/L with the majority of iron present in the soluble Fe(II) form. Upon prechlorination, iron precipitated immediately and was filtered by the media. Influent total manganese levels ranged from 52 to 245 µg/L and averaged 114.0 µg/L with the majority of manganese present in the soluble Mn(II) form. Prior to prechlorination, manganese quickly broke through the AD-33 media, reaching about 100% breakthrough after about 3,700 bed volumes of water treated. Unlike iron, manganese remained mostly in the soluble form upon

prechlorination, indicating slow oxidation kinetics. However, following the adsorption vessels, manganese was removed to below 10 µg/L, suggesting that the presence of chlorine promoted the removal of manganese on the surface of the AD-33 media.

Results of the distribution samples collected before and after the installation and operation of the APU-100 system showed no discernable trend in any of the distribution sampling results collected, indicating that the treatment system had little to no effect on the water quality in the distribution system. This was likely due to the blending of the treated water with untreated water from another well location used to supply water to the town's looped distribution system. The blending of the treated water with the untreated water might have masked any detectable effects of the APU-100 system on the water quality in the distribution system.

Three backwash water samples were collected during the first six months of system operation. Arsenic concentrations in the backwash water ranged from 11.1 to 33.4 µg/L. In most cases, arsenic, iron, and manganese concentrations were lower than those in the raw water (backwash was performed using raw water from the supply wells), indicating some removal of these metals by the media during backwash.

The capital investment cost of \$106,568 included \$82,081 for equipment, \$4,907 for site engineering, and \$19,580 for installation. Using the system's rated capacity of 100 gpm (144,000 gallon per day (gpd)), the capital cost was \$1,066 per gpm of design capacity (\$0.74/gpd) and equipment-only cost was \$821 per gpm of design capacity (\$0.57/gpd). These calculations did not include the cost of the building construction.

O&M costs included only incremental costs associated with the adsorption system, such as media replacement and disposal, chemical supply, electricity, and labor. Although not incurred during the first six months of system operation, the media replacement cost represented the majority of the O&M cost and was estimated to be \$16,810 to change out both vessels. This cost was used to estimate the media replacement cost per 1,000 gallons of water treated as a function of the projected media run length to the 10 µg/L arsenic breakthrough.

Since startup, the APU-100 system experienced higher than expected pressure drops across the treatment system and elevated inlet pressure. In multiple attempts to address these elevated pressure conditions, backwashing was conducted repeatedly with flowrates up to 11 gpm/ft<sup>2</sup>, as recommended by the vendor. However, the aggressive backwashing did not appear to be effective in solving the elevated pressure problems. Additionally, there were periods when the system was bypassed due to the elevated pressure conditions. Extensive troubleshooting and replacement of certain system components also were performed to address the problems encountered. However, as of the end of the first six months of the evaluation period, the system continued to operate under elevated pressure higher than that expected based on original design information.

# CONTENTS

FOREWORD .....	iii
ABSTRACT.....	iv
FIGURES .....	viii
TABLES .....	viii
ABBREVIATIONS AND ACRONYMS .....	ix
ACKNOWLEDGMENTS .....	xi
1.0 INTRODUCTION .....	1
1.1 Background.....	1
1.2 Treatment Technologies for Arsenic Removal.....	1
1.3 Project Objectives.....	2
2.0 CONCLUSIONS.....	3
3.0 MATERIALS AND METHODS.....	5
3.1 General Project Approach.....	5
3.2 System O&M and Cost Data Collection.....	6
3.3 Sample Collection Procedures and Schedules .....	7
3.3.1 Source Water Sample Collection.....	7
3.3.2 Treatment Plant Water Sample Collection .....	7
3.3.3 Backwash Water Sample Collection .....	7
3.3.4 Backwash Solid Sample Collection.....	7
3.3.5 Distribution System Water Sample Collection.....	8
3.4 Sampling Logistics .....	9
3.4.1 Preparation of Arsenic Speciation Kits.....	9
3.4.2 Preparation of Sampling Coolers.....	9
3.4.3 Sample Shipping and Handling .....	10
3.5 Analytical Procedures.....	10
4.0 RESULTS AND DISCUSSION.....	11
4.1 Existing Facility Description .....	11
4.1.1 Source Water Quality .....	11
4.1.2 Pre-Demonstration Treated Water Quality .....	13
4.1.3 Distribution System .....	13
4.2 Treatment Process Description .....	13
4.3 System Installation .....	16
4.3.1 Permitting .....	16
4.3.2 Building Construction.....	19
4.3.3 Installation, Shakedown, and Startup .....	19
4.4 System Operation .....	19
4.4.1 Operational Parameters.....	19
4.4.2 Differential Pressure .....	20
4.4.3 CO <sub>2</sub> Injection .....	24
4.4.4 Backwash.....	24
4.4.5 Residual Management .....	25
4.4.6 System/Operation Reliability and Simplicity .....	25
4.5 System Performance .....	27
4.5.1 Treatment Plant Sampling .....	27
4.5.2 Backwash Water Sampling.....	35

4.5.3	Distribution System Water Sampling .....	36
4.6	System Costs.....	36
4.6.1	Capital Costs.....	36
4.6.2	Operation and Maintenance Costs .....	38
5.0	REFERENCES .....	41
APPENDIX A: OPERATIONAL DATA		
APPENDIX B: ANALYTICAL DATA		

## FIGURES

Figure 4-1.	Existing Porter Well House .....	11
Figure 4-2.	Schematic of APU-100 System .....	15
Figure 4-3.	Process Flow Diagram and Sampling Locations .....	17
Figure 4-4.	Gas Injection Point for the CO <sub>2</sub> System Used for pH Adjustment .....	18
Figure 4-5.	APU-100 Treatment System.....	18
Figure 4-6.	New Treatment Building (Right) and Existing Porter Well House (Left).....	19
Figure 4-7.	Differential Pressure Loss ( $\Delta p$ ) and System Flowrate Across Vessel A During the First Six Months of Operation .....	21
Figure 4-8.	Differential Pressure Loss ( $\Delta p$ ) and System Flowrate Across Vessel B During the First Six Months of Operation .....	22
Figure 4-9.	Concentration of Arsenic Species at the IN, AP, and TT Sample Locations .....	31
Figure 4-10.	Total Arsenic Breakthrough Curve.....	32
Figure 4-11.	Total Manganese Concentrations over Time .....	33
Figure 4-12.	Concentration of Manganese Species at the IN, AP, and TT Sample Locations.....	34
Figure 4-13.	pH Values over Time.....	35
Figure 4-14.	Media Replacement and Operation and Maintenance Costs .....	40

## TABLES

Table 1-1.	Summary of Arsenic Removal Demonstration Technologies and Source Water Quality Parameters.....	2
Table 3-1.	Pre-Demonstration Study Activities and Completion Dates.....	5
Table 3-2.	General Types of Data .....	6
Table 3-3.	Sampling Schedule for Rollinsford, NH Facility .....	8
Table 4-1.	Rollinsford, NH Source Water Quality Data .....	12
Table 4-2.	Physical and Chemical Properties of AD-33 Media .....	14
Table 4-3.	Design Features of the APU-100 System.....	16
Table 4-4.	Summary of APU-100 System Operation.....	20
Table 4-5.	Summary of pH Readings Recorded at the AP Sample Location and the Inline pH Probe .....	25
Table 4-6.	Summary of Critical Analytical Results after Relocation of Chlorination Point Upstream of Adsorption Vessels.....	28
Table 4-7.	Summary of Water Quality Parameter Sampling Results after Relocation of Chlorination Point Upstream of Adsorption Vessels .....	29
Table 4-8.	Backwash Water Sampling Results .....	35
Table 4-9.	Distribution System Sampling Results.....	37
Table 4-10.	Capital Investment Costs for the APU-100 System .....	38
Table 4-11.	Operation and Maintenance Costs for the APU-100 System.....	39



## ABBREVIATIONS AND ACRONYMS

AAL	American Analytical Laboratories
Al	aluminum
AM	adsorptive media process
APU	arsenic package unit
As	arsenic
BET	Brunauer, Emmett and Teller
BV	bed volume
Ca	calcium
Cl	chloride
C/F	coagulation/filtration process
CRF	capital recovery factor
DO	dissolved oxygen
EBCT	empty bed contact time
EPA	U.S. Environmental Protection Agency
F	fluoride
Fe	iron
FRP	fiberglass reinforced plastic
GFH	granular ferric hydroxide
gpd	gallons per day
gpm	gallons per minute
HDPE	high-density polyethylene
H <sub>2</sub> SO <sub>4</sub>	sulfuric acid
HTA	Hoyle, Tanner & Associates, Inc.
ICP-MS	inductively coupled plasma-mass spectrometry
ID	identification
IX	ion exchange
LCR	Lead and Copper Rule
MCL	maximum contaminant level
MDL	method detection limit
MDWCA	Mutual Domestic Water Consumers Association
Mg	magnesium
Mn	manganese
mV	millivolts
Na	sodium
NaOCl	sodium hypochlorite
NHDES	New Hampshire Department of Environmental Services
NRML	National Risk Management Research Laboratory

NS	not sampled
O&M	operation and maintenance
ORD	Office of Research and Development
ORP	oxidation-reduction potential
psi	pounds per square inch
PO <sub>4</sub>	orthophosphate
PVC	polyvinyl chloride
QA	quality assurance
QAPP	Quality Assurance Project Plan
QA/QC	quality assurance/quality control
RPD	relative percent difference
Sb	antimony
SDWA	Safe Drinking Water Act
SiO <sub>2</sub>	silica
SM	system modification
SO <sub>4</sub> <sup>2-</sup>	sulfate
STMGID	South Truckee Meadows General Improvement District
TBD	to be determined
TCLP	toxicity characteristic leaching procedure
TDS	total dissolved solids
TOC	total organic carbon

## **ACKNOWLEDGMENTS**

The authors wish to extend their sincere appreciation to the staff of the Rollinsford Water and Sewer District in New Hampshire. Mr. Jack Hladick and his staff monitored the treatment system daily and collected samples from the treatment system and distribution system on a regular schedule throughout this reporting period. This performance evaluation would not have been possible without their efforts.

## 1.0 INTRODUCTION

### 1.1 Background

The Safe Drinking Water Act (SDWA) mandates that the U.S. Environmental Protection Agency (EPA) identify and regulate drinking water contaminants that may have adverse human health effects and that are known or anticipated to occur in public water supply systems. In 1975 under the SDWA, EPA established a maximum contaminant level (MCL) for arsenic at 0.05 mg/L. Amended in 1996, the SDWA required that EPA develop an arsenic research strategy and publish a proposal to revise the arsenic MCL by January 2000. On January 18, 2001, EPA finalized the arsenic MCL at 0.01 mg/L (EPA, 2001). In order to clarify the implementation of the original rule, EPA revised the rule text on March 25, 2003 to express the MCL as 0.010 mg/L (10 µg/L) (EPA, 2003). The final rule requires all community and non-transient, non-community water systems to comply with the new standard by January 23, 2006.

In October 2001, EPA announced an initiative for additional research and development of cost-effective technologies to help small community water systems (<10,000 customers) meet the new arsenic standard, and to provide technical assistance to operators of small systems in order to reduce compliance costs. As part of this Arsenic Rule Implementation Research Program, EPA's Office of Research and Development (ORD) proposed a project to conduct a series of full-scale, on-site demonstrations of arsenic removal technologies, process modifications, and engineering approaches applicable to small systems. Shortly thereafter, an announcement was published in the *Federal Register* requesting water utilities interested in participating in the first round of this EPA-sponsored demonstration program to provide information on their water systems. In June 2002, EPA selected 17 sites from a list of 115 sites to be the host sites for the demonstration studies. The Rollinsford Water and Sewer District was selected as one of the 17 Round 1 host sites for the demonstration program.

In September 2002, EPA solicited proposals from engineering firms and vendors for cost-effective arsenic removal treatment technologies for the 17 host sites. EPA received 70 technical proposals for the 17 host sites, with each site receiving from one to six proposals. In April 2003, an independent technical review panel reviewed the proposals and provided its recommendations to EPA on the technologies that it determined were acceptable for the demonstration at each site. Because of funding limitations and other technical reasons, only 12 of the 17 sites were selected for the demonstration project. Using the information provided by the review panel, EPA in cooperation with the host sites and the drinking water programs of the respective states selected one technical proposal for each site. AdEdge Technologies (AdEdge), using the Bayoxide E33 media developed by Bayer AG, was selected for the Rollinsford facility. AdEdge has given the E33 media the designation "AD-33."

### 1.2 Treatment Technologies for Arsenic Removal

The technologies selected for the 12 Round 1 EPA arsenic removal demonstration host sites include nine adsorptive media systems, one anion exchange system, one coagulation/filtration system, and one process modification with iron addition. Table 1-1 summarizes the locations, technologies, vendors, and key source water quality parameters (including arsenic, iron, and pH) of the 12 demonstration sites. The technology selection and system design for the 12 demonstration sites have been reported in an EPA report (Wang et al., 2004) posted on an EPA Web site (<http://www.epa.gov/ORD/NRMRL/arsenic/resource.htm>).

**Table 1-1. Summary of Arsenic Removal Demonstration Technologies and Source Water Quality Parameters**

Demonstration Site	Technology (Media)	Vendor	Design Flowrate (gpm)	Source Water Quality		
				As (µg/L)	Fe (µg/L)	pH
Bow, NH	AM (G2)	ADI	70 <sup>(a)</sup>	39	<25	7.7
Rollinsford, NH	AM (E33)	AdEdge	100	36 <sup>(b)</sup>	46	8.2
Queen Anne's County, MD	AM (E33)	STS	300	19 <sup>(b)</sup>	270 <sup>(c)</sup>	7.3
Brown City, MI	AM (E33)	STS	640	14 <sup>(b)</sup>	127 <sup>(c)</sup>	7.3
Climax, MN	C/F	Kinetico	140	39 <sup>(b)</sup>	546 <sup>(c)</sup>	7.4
Lidgerwood, ND	SM	Kinetico	250	146 <sup>(b)</sup>	1,325 <sup>(c)</sup>	7.2
Desert Sands MDWCA, NM	AM (E33)	STS	320	23 <sup>(b)</sup>	39	7.7
Nambe Pueblo, NM	AM (E33)	AdEdge	145	33	<25	8.5
Rimrock, AZ	AM (E33)	AdEdge	90 <sup>(a)</sup>	50	170	7.2
Valley Vista, AZ	AM (AAFS50)	Kinetico	37	41	<25	7.8
Fruitland, ID	IX	Kinetico	250	44	<25	7.4
STMGID, NV	AM (GFH)	USFilter	350	39	<25	7.4

AM = adsorptive media process; C/F = coagulation/filtration process; IX = ion exchange process; SM = system modification; MDWCA = Mutual Domestic Water Consumer's Association  
STMGID = South Truckee Meadows General Improvement District.

- (a) Due to system reconfiguration from parallel to series operation, the design flowrate is reduced by 50%.
- (b) Arsenic exists mostly as As(III).
- (c) Iron exists mostly as soluble Fe(II).

### 1.3 Project Objectives

The objective of the Round 1 arsenic demonstration program is to conduct 12 full-scale arsenic treatment technology demonstration studies on the removal of arsenic from drinking water supplies. The specific objectives are to:

- Evaluate the performance of the arsenic removal technologies for use on small systems.
- Determine the simplicity of required system operation and maintenance (O&M) and operator's skill levels.
- Determine the cost-effectiveness of the technologies.
- Characterize process residuals produced by the technologies.

This report summarizes the results gathered during the first six months of the AdEdge treatment system operation from February 9 through August 13, 2004. The types of data collected include system operational data, water quality data (both across the treatment train and in the distribution system), residuals characterization data, and capital and preliminary O&M cost data.

## 2.0 CONCLUSIONS

Based on the information collected during the first six months of system operation, the following conclusions were made relating to the overall objectives of the treatment technology demonstration study.

### *Performance of the arsenic removal technology for use on small systems:*

- In the absence of prechlorination, the AD-33 media was not effective at removing As(III) as demonstrated by arsenic breakthrough as high as 7.7 µg/L after only about 2,700 bed volumes of water treated.
- After switching to prechlorination, arsenic removal improved with total arsenic concentrations decreasing to less than 5 µg/L. The total arsenic concentration remained below the target level of 10 µg/L in the treated water for a throughput of 12,500 and 15,000 bed volumes. Even with pretreatment steps in place, including prechlorination and pH adjustment, arsenic breakthrough occurred sooner than predicted by the technology vendor at about 15 to 20% of the estimated working capacity of 74,000 bed volumes.
- Prior to prechlorination, manganese quickly broke through the AD-33 media, reaching about 100% breakthrough after about 3,700 bed volumes. Following prechlorination, manganese remained mostly in the soluble form; however, manganese was removed to below 10 µg/L following the adsorption vessels, indicating that the presence of chlorine promoted the removal of manganese on the surface of the AD-33 media.
- Total and free chlorine residuals measured before and after the adsorption vessels were similar, indicating little or no chlorine consumption by the AD-33 media.

### *Simplicity of required system O&M and operator's skill levels:*

- Operational issues related to higher than expected pressure drops across the treatment system, elevated inlet pressure, and the operation of the CO<sub>2</sub> injection system were the primary factors affecting system reliability and operation simplicity. Aggressive backwashing was not effective in solving the elevated pressure problems.
- Unscheduled downtime of 22% was caused by the needs to address the elevated pressures and operational problems with the CO<sub>2</sub> injection system.
- Under normal operating conditions, the skill requirements to operate the APU-100 system were minimal with a typical daily demand on the operator of 15-20 minutes. Normal operation of the system did not appear to require additional skills beyond those necessary to operate the existing water supply equipment. However, due to the  $\Delta p$  and elevated inlet pressure problems, the operator spent much more time troubleshooting the operation of the treatment system than would normally be expected.

*Process residuals produced by the technology:*

- Residuals produced by the operation of the treatment system included backwash water and spent media. Because the media was not replaced during the first six months of system operation, the only residual produced was backwash water.
- Arsenic concentrations in the backwash water ranged from 11.1 to 33.4 µg/L. In most cases, arsenic, iron, and manganese concentrations were lower than those in the raw water (backwash was performed using raw water from the supply wells), indicating some removal of these metals by the media during backwash.

*Cost-effectiveness of the technology:*

- Using the system's rated capacity of 100 gpm (144,000 gpd), the capital cost was \$1,066 per gpm of design capacity (\$0.74/gpd) and equipment-only cost was \$821 per gpm (\$0.57/gpd). These calculations did not include the cost of the building construction.
- Although not incurred during the first six months of system operation, the media replacement cost represented the majority of the O&M cost for the system and was estimated to be \$16,810 to change out both vessels.

### 3.0 MATERIALS AND METHODS

#### 3.1 General Project Approach

Following the pre-demonstration activities summarized in Table 3-1, the performance evaluation study of the AdEdge treatment system began on February 9, 2004. Table 3-2 summarizes the types of data collected and/or considered as part of the technology evaluation process. The overall performance of the system was determined based on its ability to consistently remove arsenic to the target MCL of 10 µg/L; this was monitored through the collection of weekly and monthly water samples across the treatment train. The reliability of the system was evaluated by tracking the unscheduled system downtime and the frequency and extent of repair and replacement. The unscheduled downtime and repair information were recorded by the plant operator on a Repair and Maintenance Log Sheet.

**Table 3-1. Pre-Demonstration Study Activities and Completion Dates**

<b>Activity</b>	<b>Date</b>
Introductory Meeting Held	August 5, 2003
Request for Quotation Issued to Vendor	August 7, 2003
Draft Letter of Understanding Sent Out	August 13, 2003
Final Letter of Understanding Sent Out	September 9, 2003
Vendor Quotation Received	September 10, 2003
Purchase Order Completed and Signed	October 6, 2003
Letter Report Issued	October 17, 2003
Building Construction Began	November 3, 2003
Draft Study Plan Issued	November 26, 2003
Engineering Package Submitted to NHDES	December 19, 2003
Building Construction Completed	December 22, 2003
APU-100 Shipped by AdEdge	December 23, 2003
APU-100 Delivered to Site and System Installation Began	January 8, 2004
Permit for Treatment System Issued by NHDES	January 12, 2004
Final Study Plan Issued	January 21, 2004
System Installation Completed	January 23, 2004
System Shakedown Completed	January 30, 2004
Performance Evaluation Begun	February 9, 2004

NHDES = New Hampshire Department of Environmental Services.

Simplicity of the system operation and the level of operator skill required were evaluated based on a combination of quantitative data and qualitative considerations, including any pre-treatment and/or post-treatment requirements, level of system automation, operator skill requirements, task analysis of the preventive maintenance activities, frequency of chemical and/or media handling and inventory requirements, and general knowledge needed for safety requirements and chemical processes. The staffing requirements on the system operation were recorded on a Field Log Sheet.



**Table 3-2. General Types of Data**

<b>Evaluation Objectives</b>	<b>Data Collection</b>
Performance	-Ability to consistently meet 10 µg/L of arsenic in effluent
Reliability	-Unscheduled downtime for system -Frequency and extent of repairs to include man hours, problem description, description of materials, and cost of materials
Simplicity of Operation and Operator Skill	-Pre- and post-treatment requirements -Level of system automation for data collection and system operation -Staffing requirements including number of operators and man hours -Task analysis of preventive maintenance to include man hours per month and number and complexity of tasks -Chemical handling and inventory requirements -General knowledge needed of safety requirements and chemical processes
Cost-Effectiveness	-Capital costs including equipment, engineering, and installation -O&M costs including chemical and/or media usage, electricity, and labor
Residual Management	-Quantity of the residuals generated by the process -Characteristics of the aqueous and solid residuals

The cost-effectiveness of the system is evaluated based on the cost per 1,000 gallons (\$/1,000 gallons) of water treated. This requires the tracking of capital costs such as equipment, engineering, and installation costs, as well as O&M costs for media replacement and disposal, chemical supply, electrical power use, and labor hours. The capital costs have been reported in an EPA report (Chen et al., 2004) posted on an EPA Web site (<http://www.epa.gov/ORD/NRMRL/arsenic/resource.htm>). Data on O&M costs were limited to chemicals, electricity, and labor hours because media replacement did not take place during the six months of operation.

The quantity of aqueous and solid residuals generated was estimated by tracking the amount of backwash water produced during each backwash cycle and the need to replace the media upon arsenic breakthrough. Backwash water was sampled and analyzed for chemical characteristics.

### **3.2 System O&M and Cost Data Collection**

The plant operator performed daily, weekly, and monthly system O&M and data collection following the instructions provided by the vendor and Battelle. On a daily basis, the plant operator recorded system operational data, such as pressure, flowrate, totalizer, and hour meter readings on a Battelle-provided Daily Field Log Sheet; checked the sodium hypochlorite drum level; checked the CO<sub>2</sub> injection system used for pH adjustment; and conducted visual inspections to ensure normal system operations. In the event of problems, the plant operator would contact the Battelle Study Lead, who then would determine if the vendor should be contacted for troubleshooting. Often times, after the Battelle Study Lead was notified, the plant operator and the vendor would confer directly to troubleshoot an operational problem. Once a week, the plant operator measured water quality parameters, including temperature, pH, dissolved oxygen (DO)/oxidation-reduction potential (ORP), and residual chlorine and recorded the data on a Weekly Water Quality Parameters Log Sheet. The original system design and operational information provided by the vendor suggested that a monthly backwash of the media would be necessary. In multiple attempts to address elevated pressure drop problems observed across the treatment system, backwashing was conducted repeatedly with aggressive flowrates up to 11 gpm/ft<sup>2</sup>, as recommended by the vendor. See Section 4.4 for further discussion of the operational conditions experienced at the site.

Capital costs for the AdEdge treatment system consisted of costs for equipment, site engineering, and system installation. The O&M costs consisted primarily of costs for the media replacement and spent media

disposal, chemical and electricity consumption, and labor. The sodium hypochlorite and CO<sub>2</sub> usage, as well as electricity consumption, were tracked using the Daily Field Log Sheet. Labor hours for various activities, such as the routine system O&M, system troubleshooting and repair, and demonstration-related work, were tracked using an Operator Labor Hour Record. The routine O&M included activities such as completing the daily field logs, replenishing the sodium hypochlorite solution, replacing the CO<sub>2</sub> tanks, performing system inspection, and other miscellaneous routine requirements. The demonstration-related work included activities such as performing field measurements, collecting and shipping samples, and communicating with the Battelle Study Lead. The demonstration-related activities were recorded but not included in the cost analysis.

### **3.3 Sample Collection Procedures and Schedules**

To evaluate the performance of the system, samples were collected from the source, treatment plant, distribution system, and adsorptive vessel backwash. Table 3-3 provides the sampling schedules and analytes measured during each sampling event. Specific sampling requirements for analytical methods, sample volumes, containers, preservation, and holding times are presented in Table 4-1 of the EPA-endorsed Quality Assurance Project Plan (QAPP) (Battelle, 2003).

**3.3.1 Source Water Sample Collection.** During the initial visit to the site, Battelle collected one set of source water samples for detailed water quality analyses. The source water also was speciated for particulate and soluble arsenic, iron (Fe), manganese (Mn), aluminum (Al), and As(III) and As(V). The sample tap was flushed for several minutes before sampling; special care was taken to avoid agitation, which might cause unwanted oxidation. Arsenic speciation kits and containers for water quality samples were prepared as described in Section 3.4.

**3.3.2 Treatment Plant Water Sample Collection.** During the system performance evaluation study, water samples were collected weekly across the treatment train by the plant operator. After receiving training from Battelle, the plant operator also performed on-site arsenic speciation once every four weeks. Sampling taps were installed by the vendor before the commencement of the evaluation study. Samples were collected weekly, on a four-week cycle. For the first week of each four-week cycle, treatment plant samples were collected at three locations: at the wellhead (IN), after pH adjustment but before splitting to the two vessels (AP), and from the combined effluent of Vessels A and B (TT) (as designated in Table 3-3). The three samples (IN, AP, and TT) collected during this first week were analyzed for the monthly treatment plant analyte list shown in Table 3-3. For the second, third, and fourth week of each cycle, treatment plant samples were collected at four locations: IN, AP, after Vessel A (TA), and after Vessel B (TB). These samples were analyzed for the weekly treatment plant analyte list shown in Table 3-3.

**3.3.3 Backwash Water Sample Collection.** Three backwash water samples were collected on April 26, June 8, and July 22 from sample taps installed in the backwash water effluent line from each vessel. Unfiltered samples were sent to American Analytical Laboratories (AAL) for pH, total dissolved solids (TDS) and turbidity measurements. Filtered samples using 0.45- $\mu$ m disc filters were sent to Battelle's inductively coupled plasma-mass spectrometry (ICP-MS) laboratory for soluble As, Fe, and Mn analyses. Arsenic speciation was not performed for the backwash water samples.

**3.3.4 Backwash Solid Sample Collection.** Backwash solid samples were not collected in the initial six months of this demonstration. Two to three solid/sludge samples will be collected from the backwash leach area if possible during the course of the second half of the demonstration study. The solid/sludge samples will be collected in glass jars and submitted to TCCI Laboratories for toxicity characteristic leaching procedure (TCLP) tests.

**Table 3-3. Sampling Schedule for Rollinsford, NH Facility**

Sample Type	Sample Locations	No. of Samples	Frequency	Analytes	Date(s) Samples Collected
Source Water	Wellhead (IN)	1	Once during the initial site visit	As(total), particulate and soluble As, As(III), As(V), Fe (total and soluble), Mn (total and soluble), Al (total and soluble), Na, Ca, Mg, F, Cl, SO <sub>4</sub> , SiO <sub>2</sub> , PO <sub>4</sub> , TOC, and alkalinity.	08/05/03
Treatment Plant Water (Three of every four weeks)	Wellhead (IN), after pH adjustment (AP), after Vessel A (TA), and after Vessel B (TB)	4	Weekly	On-site: pH, temperature, DO/ORP, Cl <sub>2</sub> (free and total, except at wellhead). Off-Site: As (total), Fe (total), Mn (total), SiO <sub>2</sub> , PO <sub>4</sub> , turbidity, and alkalinity.	<b>02/10/04</b> , 02/17/04, 02/24/04, 03/02/04, <b>03/09/04</b> , 03/30/04, 04/06/04, 04/14/04, <b>04/19/04</b> , 04/29/04, 05/05/04, 05/18/04, <b>05/25/04</b> , 06/08/04, 06/22/04, <b>07/13/04</b> , 07/20/04, 07/29/04, 08/04/04, <b>08/10/04</b>
Treatment Plant Water (Once every four weeks)	Wellhead (IN), after pH adjustment (AP), and combined effluent (TT)	3	Monthly	On-site: pH, temperature, DO/ORP, and Cl <sub>2</sub> (free and total, except at wellhead). Off-Site: As(total), particulate and soluble As, As(III), As(V), Fe (total and soluble), Mn (total and soluble), Ca, Mg, F, NO <sub>3</sub> , SO <sub>4</sub> , SiO <sub>2</sub> , PO <sub>4</sub> , turbidity, and alkalinity	06/22/04, <b>07/13/04</b> , 07/20/04, 07/29/04, 08/04/04, <b>08/10/04</b>
Distribution Water	One home (a non-LCR sampling site) and two non-residences within the area served by Wells No. 3 and No. 4	3	Monthly	pH, alkalinity, As, Fe, Mn, Pb, and Cu.	Baseline sampling <sup>(a)</sup> : 12/10/03, 01/06/04, 01/21/04  Monthly sampling: 03/03/04, 04/09/04, 05/26/04, 07/27/04
Backwash Water	From backwash discharge line	2	Monthly	TDS, turbidity, pH, As (soluble), Fe (soluble), and Mn (soluble)	04/26/04, 06/08/04, 07/22/04
Residual Sludge	From backwash discharge area	2-3	TBD	TCLP Metals	TBD

(a) Three baseline sampling events were performed before the system became operational.

LCR = Lead and Copper Rule.

TBD = to be determined.

Bold font indicates that field speciation was performed.

**3.3.5 Distribution System Water Sample Collection.** Samples were collected from the distribution system to determine what impact the addition of the arsenic treatment system would have on the water chemistry in the distribution system, specifically, the lead and copper level. In December 2003 and January 2004, prior to the startup of the treatment system, three baseline distribution sampling events were conducted at three locations per sampling event within the distribution system. Following the installation of the arsenic adsorption system, distribution system sampling continued on a monthly basis at the same three locations.

Baseline and monthly distribution system samples were collected by the plant operator and by one homeowner. Samples were collected at one home, not included as a Lead and Copper Rule (LCR) sampling residence, as well as two non-residences. The locations were selected to maximize the likelihood that the water supplied to these locations was produced by Wells No. 3 and No. 4, which were treated by the arsenic removal system. Because the system was a looped drinking water system and was served by additional wells besides Wells No. 3 and No. 4, it was possible that the water collected from the distribution system was from a source other than Wells No. 3 and No. 4 (see Section 4.1). Analytes for the baseline samples coincided with the monthly distribution water samples as described in Table 3-3. Arsenic speciation was not performed on the distribution water samples. The samples collected for the distribution study were taken following an instruction sheet developed according to the *Lead and Copper Monitoring and Reporting Guidance for Public Water Systems* (EPA, 2002). Sampling at the two non-residence locations was performed with the first sample taken at the first draw and the second sample taken after flushing the sample tap for several minutes. The first draw sample was collected from a cold-water faucet that had not been used for at least six hours to ensure that stagnant water was sampled. The sampler recorded the date and time of last water use before sampling and the date and time of sample collection for calculation of the stagnation time.

### **3.4 Sampling Logistics**

All sampling logistics including arsenic speciation kits preparation, sample cooler preparation, and sample shipping and handling are discussed as follows:

**3.4.1 Preparation of Arsenic Speciation Kits.** The arsenic field speciation method used an anion exchange resin column to separate the soluble arsenic species, As(V) and As(III) (Edwards et al., 1998). Arsenic speciation kits were prepared in batches at Battelle laboratories according to the procedures detailed in Appendix A of the EPA-endorsed QAPP (Battelle, 2003).

**3.4.2 Preparation of Sampling Coolers.** All sample bottles were new and contained appropriate preservatives. Each sample bottle was taped with a pre-printed, color-coded, and waterproof label. The sample label consisted of sample identification (ID), date and time of sample collection, sampler initials, location, sent to, analysis required, and preservative. The sample ID consisted of a two-letter code for a specific water facility, the sampling date, a two-letter code for a specific sampling location, and a one-letter code for the specific analysis to be performed. The sampling locations were color-coded for easy identification. For example, red, orange, yellow, and green were used to designate sampling locations for IN, TA, TB, and TT, respectively. Pre-labeled bottles were placed in one of the plastic bags (each corresponding to a specific sampling location) in a sample cooler. When arsenic speciation samples were to be collected, an appropriate number of arsenic speciation kits also were included in the cooler.

When appropriate, the sample cooler was packed with bottles for the three distribution system sampling locations and/or the two backwash sampling locations (one for each vessel). For the distribution system sampling, each set of bottles consisted of one 1-L high-density polyethylene (HDPE) wide-mouth bottle with no preservative for pH and alkalinity analyses, and one 250-mL plastic bottle for metals analysis (As, Fe, Mn, Pb, and Cu), which was preserved with nitric acid upon receipt at the laboratory. For the backwash sampling, each set of bottles consisted of one 1-gal wide-mouth HDPE jar with no preservative used for analysis of pH, TDS, and turbidity, and one 125-mL HDPE bottle preserved with 0.625 mL of 40% ultrapure nitric acid, which was to be filled with 60 mL of a filtered sample for analysis of soluble As, Fe, and Mn.

In addition, a packet containing all sampling and shipping-related supplies, such as latex gloves, sampling instructions, chain-of-custody forms, prepaid Federal Express air bills, ice packs, and bubble wrap, also was placed in the cooler. Except for the operator's signature, the chain-of-custody forms and prepaid

Federal Express air bills had already been completed with the required information. The sample coolers were shipped via Federal Express to the facility approximately one week prior to the scheduled sampling date.

**3.4.3 Sample Shipping and Handling.** After sample collection, samples for off-site analyses were packed carefully in the original coolers with wet ice and shipped to Battelle. Upon receipt, sample custodians verified that all samples indicated on the chain-of-custody forms were included and intact. Sample label identifications were checked against the chain-of-custody forms and the samples were logged into the laboratory sample receipt log. Discrepancies, if noted, were addressed by the field sample custodian, and the Battelle Study Lead was notified.

Samples for water quality analyses by Battelle's subcontract laboratories were packed in coolers at Battelle and picked up by a courier from either AAL (Columbus, OH) or TCCI Laboratories (New Lexington, OH). The samples for arsenic speciation analyses were stored at Battelle's ICP-MS Laboratory. The chain-of-custody forms remained with the samples from the time of preparation through analysis and final disposition. All samples were archived by the appropriate laboratories for the respective duration of the required hold time, and disposed of properly thereafter.

### **3.5 Analytical Procedures**

The analytical procedures are described in detail in Section 4.0 of the EPA-endorsed QAPP (Battelle, 2003). Field measurements of pH, temperature, and DO/ORP were conducted by the plant operator using a WTW Multi 340i handheld meter, which was calibrated prior to use following the procedures provided in the user's manual. The plant operator collected a water sample in a 400-mL plastic beaker and placed the Multi 340i probe in the beaker until a stable measured value was reached. The plant operator also performed free and total chlorine measurements using Hach chlorine test kits.

Laboratory quality assurance/quality control (QA/QC) of all methods followed the guidelines provided in the QAPP (Battelle, 2003). Data quality in terms of precision, accuracy, method detection limit (MDL), and completeness met the criteria established in the QAPP, i.e., relative percent difference (RPD) of 20%, percent recovery of 80-120%, and completeness of 80%. The quality assurance (QA) data associated with each analyte will be presented and evaluated in a QA/QC Summary Report to be prepared under separate cover and to be shared with the other 11 demonstration sites included in the Round 1 arsenic study.

## 4.0 RESULTS AND DISCUSSION

### 4.1 Existing Facility Description

The treatment system supplies water to the town of Rollinsford and services about 450 connections. The water source is supplied by three bedrock wells, two of which, Wells No. 3 and No. 4, are controlled through the Porter well house shown in Figure 4-1. The Porter well house is located in a wooded area approximately ¼ of a mile south of the town of Rollinsford. Water from these two wells are combined and treated before being sent to the distribution system. The third supply well, the General Sullivan well, is located approximately 1.5 miles north of the Porter well house. Because the General Sullivan well is completely separated from the Porter well house, this well was not treated by the AdEdge APU-100 treatment system as part of the demonstration study.



**Figure 4-1. Existing Porter Well House**

**4.1.1 Source Water Quality.** Source water samples were collected at a sampling tap inside the Porter well house from the combined flow from Wells No. 3 and No. 4 on August 5, 2003 and subsequently analyzed for the analytes shown in Table 3-3. The results of the source water analyses, along with those provided by the facility to EPA for the demonstration site selection and those independently collected and analyzed by EPA, are presented in Table 4-1.

Total arsenic concentrations of the source water ranged from 33.8 to 55.9 µg/L. Based on the August 5, 2003 sampling results, total arsenic concentration in the source water was 36.2 µg/L, of which 33.9 µg/L was soluble As and 2.3 µg/L was particulate As. Of the soluble As, 20.1 µg/L existed as As(III) (59%) and 13.9 µg/L as As(V) (41%).

The pH values of the raw water samples ranged between 7.4 and 8.4. At pH values greater than 8.0 to 8.5, AdEdge recommended that the water be adjusted for pH in order to maintain the adsorption capacity

**Table 4-1. Rollinsford, NH Water Quality Data**

Parameter	Units	Utility Raw Water Data <sup>(a)</sup>	EPA Raw Water Data <sup>(b)</sup>	EPA Raw Water Data <sup>(c)</sup>	Battelle Raw Water Data <sup>(a)</sup>	NHDES Raw Water Data <sup>(a)</sup>	NHDES Treated Water Data <sup>(d)</sup>
<i>Sampling Date</i>		NA	09/16/02	09/16/02	08/05/03	2000 – 03	2000 – 03
pH	–	8.4	NS	NA	7.4	8.4 <sup>(f)</sup>	8.6 <sup>(g)</sup>
Total Alkalinity	mg/L (as CaCO <sub>3</sub> )	176.0	179.2	189.4	171.0	176 <sup>(f)</sup>	110 <sup>(g)</sup>
Hardness	mg/L (as CaCO <sub>3</sub> )	50.0	46.6	40.9	50.9	49.7 <sup>(f)</sup>	24.2 – 26.1
Turbidity	mg/L	NS	NS	NS	NS	NS	NS
Chloride	mg/L	42.0	42.3	47.7	48.0	42.0 <sup>(f)</sup>	8.7 <sup>(g)</sup>
Fluoride	mg/L	NS	NS	NS	0.8	0.57 <sup>(f)</sup>	0.37 – 0.38
Sulfate	mg/L	38.0	40.5	29.0	36.0	38	21
Silica (as SiO <sub>2</sub> )	mg/L	13.7	14.3	13.1	13.6	NS	NS
Orthophosphate	mg/L	0.07 <sup>(e)</sup>	NS	NS	<0.10	NS	NS
TOC	mg/L	NS	NS	NS	<1.0	NS	NS
As(total)	µg/L	34.0-55.0	39.0	45.0	36.2	33.8 – 55.9	19.6 – 24.0
As (total soluble)	µg/L	NS	NS	NS	33.9	NS	NS
As (particulate)	µg/L	NS	NS	NS	2.3	NS	NS
As(III)	µg/L	NS	NS	NS	20.1	NS	NS
As(V)	µg/L	NS	NS	NS	13.9	NS	NS
Total Fe	µg/L	206.0	189.0	114.0	46.3	206 <sup>(f)</sup>	<50 <sup>(g)</sup>
Soluble Fe	µg/L	NS	NS	NS	<30	NS	NS
Total Al	µg/L	NS	<25	<25	<10	NS	NS
Soluble Al	µg/L	NS	NS	NS	<10	NS	NS
Total Mn	µg/L	88.0	100.5	56.7	70.8	88.2 <sup>(f)</sup>	20.0 – 20.8
Soluble Mn	µg/L	NS	NS	NS	68.6	NS	NS
Total V	µg/L	NS	NS	NS	<0.1	NS	NS
Soluble V	µg/L	NS	NS	NS	<0.1	NS	NS
Total Mo	µg/L	NS	NS	NS	<0.1	NS	NS
Soluble Mo	µg/L	NS	NS	NS	<0.1	NS	NS
Total Sb	µg/L	NS	<25	<25	<0.1	<2 <sup>(f)</sup>	<2 <sup>(g)</sup>
Soluble Sb	µg/L	NS	NS	NS	<0.1	NS	NS
Total Na	mg/L	93.0	108.9	98.8	101.8	93.2 <sup>(f)</sup>	50.8 – 52.0
Total Ca	mg/L	10 <sup>(e)</sup>	9.9	10.1	11.6	NS	NS
Total Mg	mg/L	5 <sup>(e)</sup>	5.3	3.8	5.3	NS	NS

(a) Collected from combined flow from Wells No. 3 and No. 4.

(b) Well No. 3.

(c) Well No. 4.

(d) Treated water data collected at residences.

(e) Data provided by EPA.

(f) Only one data point available for this time period for this parameter (Sample date – 11/19/01).

(g) Only one data point available for this time period for this parameter (Sample date – 04/12/00).

NS = Not Sampled.

of the AD-33 media. Therefore, the treatment process included a carbon dioxide (CO<sub>2</sub>) injection module for pH adjustment prior to arsenic adsorption. The target pH after adjustment was 7.0.

The source water iron levels ranged from 46.3 to 206 µg/L, and did not require removal prior to the adsorption process. Manganese concentrations ranged from 56.7 to 100.5 µg/L. The concentrations of orthophosphate and silica were sufficiently low (i.e., <0.1 mg/L and <14.3 mg/L, respectively) to have no affect on the adsorption of arsenic by the AD-33™ media.

**4.1.2 Pre-Demonstration Treated Water Quality.** Treated water samples (postchlorination) were collected by the NHDES prior to the demonstration study and analyzed for the constituents shown in Table 4-1. The concentrations of these constituents were somewhat lower than those in the raw water, with the exception of pH, which was slightly higher (8.6 in the treated water versus 8.4 in the raw water sample).

**4.1.3 Distribution System.** The town of Rollinsford receives its water via a looped drinking water distribution system, with water supplied from the three wells described in Section 4.1. Wells No. 3 and No. 4 are combined and sent to the distribution system from the Porter well house shown in Figure 4-1. Excess water generated by the supply wells is sent under pressure to an elevated storage tank. The water distribution mains are constructed of either asbestos cement, cast iron, or ductile iron. The connections to the water system and piping within the residences themselves are primarily copper or polyvinyl chloride (PVC) pipe.

The Rollinsford Water and Sewer District samples water from the distribution system for various parameters. Each month, two locations within the distribution system are sampled for bacterial analyses including *E. coli* and total coliform. The Porter well is sampled quarterly at the wellhead for total arsenic. Under the LCR, samples are collected from customer taps at 25 residences every three years.

## 4.2 Treatment Process Description

AdEdge's APU is designed for arsenic removal for small systems in the flow range of 5-100 gpm. It uses Bayoxide E33 media (branded as AD-33 by AdEdge), an iron-based adsorptive media developed by Bayer AG, for the removal of arsenic from drinking water supplies. Table 4-2 presents physical and chemical properties of the media. AD-33 media is delivered in a dry crystalline form and is listed by NSF under Standard 61 for use in drinking water applications.

The AdEdge APU is a fixed bed down-flow adsorption system using the AD-33 media for the adsorption of dissolved arsenic. Figure 4-2 is a simplified instrumentation diagram of the APU-100 system. When the media reaches its capacity, it is removed and disposed of after being tested for EPA's TCLP.

AdEdge provided an APU-100 adsorption system for demonstration at the Rollinsford site. The APU-100 system consists of two pressure vessels operating in parallel. Due to the slightly elevated pH of the raw water, a pH adjustment module was included as part of the arsenic adsorption system. Table 4-3 presents the key system design parameters. Figure 4-3 shows the generalized process flow for the system including sampling locations and parameters to be analyzed. Five key process components are discussed as follows:

- **Intake.** Raw water was pumped from Wells No. 3 and No. 4 and combined at the Porter well house before feeding the APU-100 treatment system.
- **pH Adjustment.** The pH of the feed water was adjusted to approximately 7.0 (±0.2 pH units) through the use of a CO<sub>2</sub> injection module. pH adjustment of the



**Table 4-2. Physical and Chemical Properties of AD-33 Media<sup>(a)</sup>**

<i>Physical Properties</i>	
<b>Parameter</b>	<b>Value</b>
Matrix	Iron oxide composite
Physical form	Dry granules
Color	Amber
Bulk Density (lb/ft <sup>3</sup> )	28.1
BET Area (m <sup>2</sup> /g)	142
Attrition (%)	0.3
Moisture Content (%)	<15% (by weight)
Particle size distribution	10 × 35 mesh
Crystal Size (Å)	70
Crystal Phase	$\alpha$ – FeOOH
<i>Chemical Analysis</i>	
<b>Constituents</b>	<b>Weight %</b>
FeOOH	90.1
CaO	0.27
MgO	1.00
MnO	0.11
SO <sub>3</sub>	0.13
Na <sub>2</sub> O	0.12
TiO <sub>2</sub>	0.11
SiO <sub>2</sub>	0.06
Al <sub>2</sub> O <sub>3</sub>	0.05
P <sub>2</sub> O <sub>5</sub>	0.02
Cl	0.01

(a) Provided by Bayer AG.

BET = Brunauer, Emmett, and Teller

raw water was used to help enhance the adsorption capacity of the AD-33 media. The pH adjustment module consisted of CO<sub>2</sub> storage (in liquid form) and a feed vaporizer, which vaporized the liquid CO<sub>2</sub> prior to injection into the system. Figure 4-4 shows the injection point for the CO<sub>2</sub> into the piping system. The CO<sub>2</sub> pH adjustment module was located upstream of the arsenic adsorption vessels as shown in the instrumentation diagram in Figure 4-2. Dosage in the water line was controlled by a pH loop. The use of CO<sub>2</sub> for pH adjustment in this application has two advantages: 1) it is not inherently corrosive as compared to using acids such as sulfuric acid (H<sub>2</sub>SO<sub>4</sub>) for lowering pH, and 2) when the water is depressurized, upon exiting the adsorption vessels, some CO<sub>2</sub> gasifies, thus raising the pH value of the treated water.

- Post-/Prechlorination.** The existing chlorine injection system was used to chlorinate the source water. During the first one and a half months of operation, chlorine was fed at the end of the treatment train following the APU-100 adsorption system. In March 2004, total arsenic levels in the treated water measured as high as 7.7 µg/L, much earlier than projected, and the majority of arsenic passing through the AD-33 media was As(III). In late March 2004, the treatment system was retrofitted with a new chlorine addition point upstream of the adsorption vessels and after the CO<sub>2</sub> injection point. With this prechlorination step in place, As(III) was oxidized to As(V) to improve the adsorption capacity of the media.

**Process Flow Diagram**  
**AdEdge Arsenic Reduction System w/ pH Control**  
**APU 100 System**

**Rollinsford, New Hampshire**

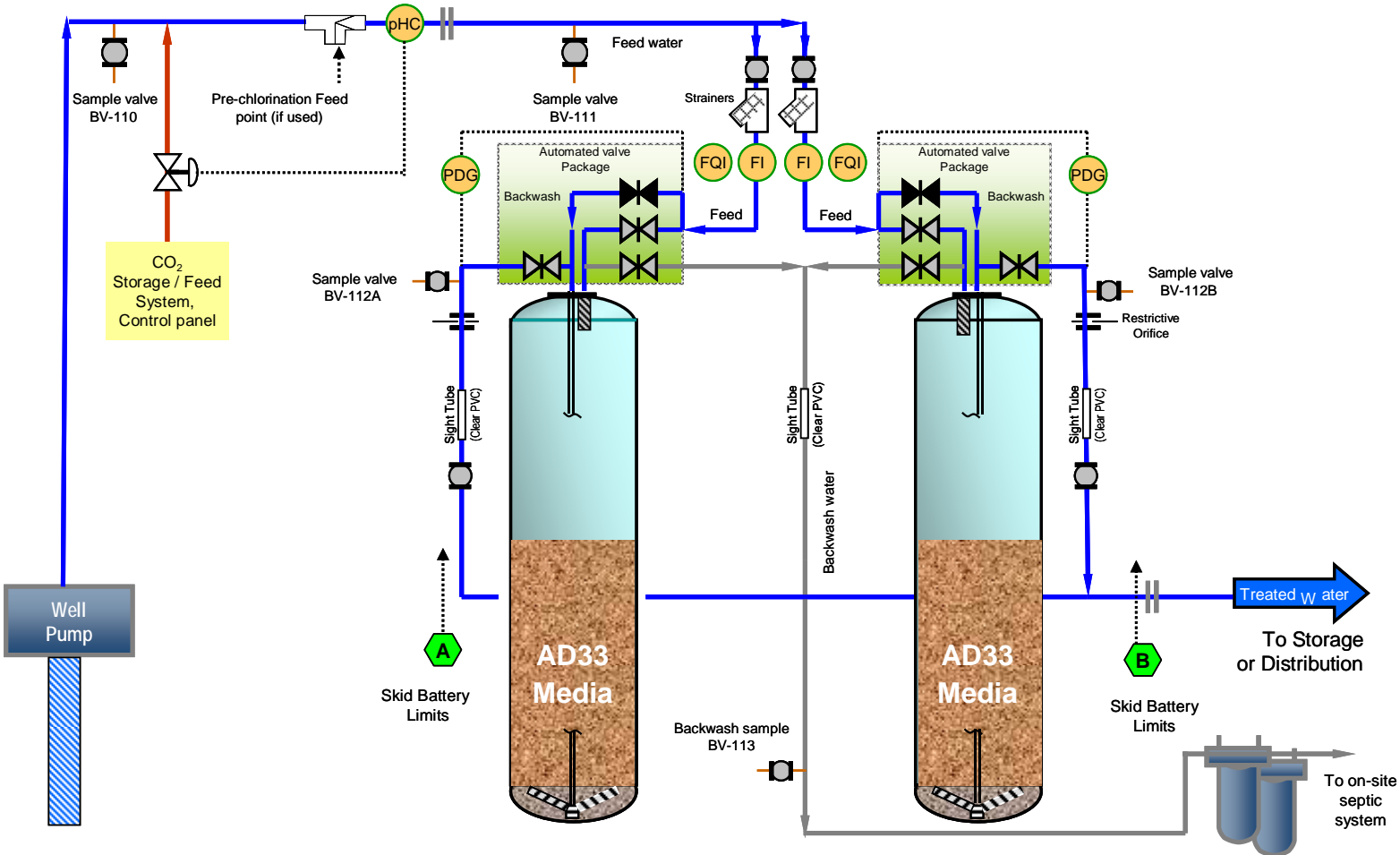

15

**Figure 4-2. Schematic of APU-100 System**

**Table 4-3. Design Features of the APU-100 System**

<b>Design Parameter</b>	<b>Value</b>	<b>Remarks</b>
Number of adsorbers	2	–
Configuration	Parallel	–
Vessel size (inches)	36 × 72	–
Type of media	Bayoxide E33	–
Quantity of media (ft <sup>3</sup> /vessel)	27	–
Pre-treatment	pH adjustment	Using CO <sub>2</sub>
Backwash Frequency (per month)	1 (or as needed)	Based on differential pressure increase across vessels
Backwash Duration (min/vessel)	20-25	10-15 bed volumes
Peak flowrate (gal/min)	100	Typical expected
EBCT (min)	4.0	Based on peak flow of 100 gpm
Average use rate (gal/day)	60,000	Based on 10 hours of daily operation at 100 gpm
Estimated working capacity (BV)	74,000	Bed volumes to breakthrough
Estimated volume to breakthrough (gal)	29,890,080	1BV = 400 gal (both vessels)
Estimated media life (months)	16.8	Based on 10 hours of daily operation at 100 gpm

- **Adsorption System.** The APU-100 system consisted of two 36-inch-diameter, 72-inch-tall pressure vessels in parallel configuration, each initially containing 27 ft<sup>3</sup> of AD-33 media supported by a gravel underbed. The tanks were fiberglass-reinforced plastic (FRP) construction, rated for 150 pounds per square inch (psi) working pressure, skid-mounted, and piped to a valve rack mounted on a polyurethane-coated, welded frame. Empty bed contact time (EBCT) for the system was approximately 4.0 minutes based on a media volume of 27 ft<sup>3</sup> per vessel. Hydraulic loading to each vessel based on a design flowrate of 100 gpm (50 gpm to each vessel) was about 7 gpm/ft<sup>2</sup>. Figure 4-5 shows the installed APU-100 system.
- **Backwash.** Based upon a set time or a set pressure differential, the adsorption vessels were taken off-line one at a time for backwash using raw water from the source well. The purpose of the backwash was to remove particulates and media fines accumulating in the beds. The backwash water produced was discharged to an on-site subsurface infiltration area for disposal.

### 4.3 System Installation

The installation of the APU-100 system was completed in January 2004. The system installation was completed by Waterline Services, a construction subcontractor to AdEdge. The building construction activities were carried out primarily by the local plant operator.

**4.3.1 Permitting.** Two permits were applied for and received from the NHDES. In late September 2003, design drawings for the proposed treatment system, new treatment building, and subsurface disposal area were submitted to the NHDES by Hoyle, Tanner, & Associates (HTA), an engineering consultant hired by the Rollinsford Water and Sewer District. Also, an Application for Nondomestic Wastewater Discharge to groundwater was submitted for backwash disposal into the subsurface infiltration area. NHDES granted the discharge permit on December 30, 2003 and the treatment system permit on January 12, 2004.

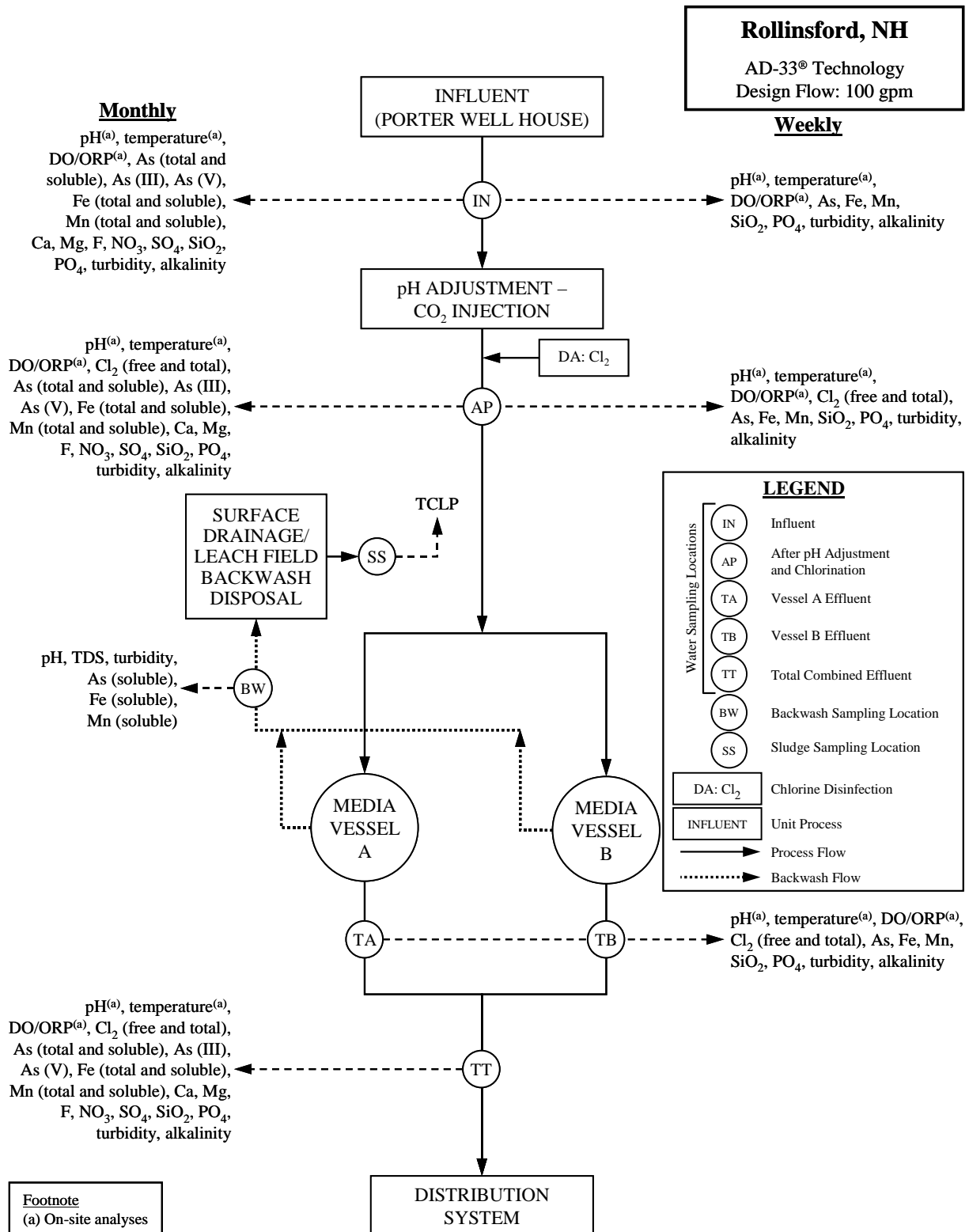

Figure 4-3. Process Flow Diagram and Sampling Locations



**Figure 4-4. Gas Injection Point for the CO<sub>2</sub> System Used for pH Adjustment**



**Figure 4-5. APU-100 Treatment System**

**4.3.2 Building Construction.** Building construction began on November 3, 2003 and was completed on December 22, 2003. The 33-ft × 13-ft building has a concrete foundation and floor and a wood frame with vinyl siding. It includes two 10-ft roll-up doors on the front allowing access to the treatment equipment, and one walk-through door on the end of the building (Figure 4-6). Additionally, the Water and Sewer District installed a subsurface drainage structure in the parking area in front of the building to handle the disposal of backwash water generated by the treatment system.



**Figure 4-6. New Treatment Building (Right) and Existing Porter Well House (Left)**

**4.3.3 Installation, Shakedown, and Startup.** The treatment system was shipped on December 23, 2003 and arrived at the site on January 8, 2004. Waterline Services, the installation subcontractor, began system installation that same day. AdEdge and Waterline completed system installation on January 16, 2004.

Battelle, AdEdge, Waterline, and the local operator completed system shakedown and startup procedures on January 29 and 30, 2004. During the first day, the media in both vessels was backwashed and the flows to each vessel adjusted so that they were balanced. Battelle provided operator training on data and sample collection and conducted a review of the piping and instrumentation diagram and system checklist with the vendor.

On January 30, the system was put into service mode for the first time. While operating, leaks were detected in the CO<sub>2</sub> injection system caused by cracks in the plastic seals in the piping joints. Because of these leaks and required repairs, the system was not put into regular service until February 9, 2004.

## **4.4 System Operation**

**4.4.1 Operational Parameters.** The operational parameters for the first six months of the system operation are tabulated and attached as Appendix A. Key parameters are summarized in Table 4-4. From February 9 through August 13, 2004, the APU-100 system operated for approximately 1,800 hours, based on readings collected daily at the well pump hour meters. The operating time for each well shown in Table 4-4 was lower than the total operating time for the system due to both wells being inoperable during certain periods of time. The 1,800 hours of operation represented a use rate of approximately 40% during this 27-week period. The system typically operated for a period of approximately 10 hours per day. The well pumps, which were controlled by a timer, normally came on in the evening about 10:00 P.M. and went off at approximately 8:00 A.M.



**Table 4-4. Summary of APU-100 System Operation**

Operational Parameter	Value / Condition		
Duration	02/09/04 – 08/13/04 (Week 1 – Week 27)		
	Well No. 3	Well No. 4	
Cumulative Operating Time (hr)	1676	1193	
Average Daily Operating Time (hr) <sup>(a)</sup>	~ 10 with both wells operating	~ 10 with both wells operating	
	Vessel A	Vessel B	Total
Throughput (kgal)	3,439	3,718	7,158
Average Flowrate (gpm) <sup>(b)</sup>	38	40	82
Range of Flowrate (gpm) <sup>(b)</sup>	19-62	25-63	42-115
Average EBCT (min) <sup>(c)</sup>	5.1	4.8	NA
Range of EBCT (min) <sup>(c)</sup>	3.0-9.0	2.9-7.5	NA
Average Inlet Pressure (psi)	NA	NA	83
Range of Inlet Pressure (psi)	NA	NA	71-100+ <sup>(d)</sup>
Average Outlet Pressure (psi)	NA	NA	65
Range of Outlet Pressure (psi)	NA	NA	60-68
Pressure Loss, $\Delta p$ (psi)	7-30+ <sup>(d)</sup>	8-30+ <sup>(d)</sup>	8-36+ <sup>(d)(e)</sup>
Time between Consecutive Backwash Events (days) <sup>(f)</sup>	1-19 (6)	1-19 (6)	NA

- (a) Average daily operating times include only those days when the treatment system was in operation. The average does not include periods when the treatment system was not in service. Overall average daily operating time was 10 hours/day.
- (b) Average flowrate and range of flowrates including periods when only one supply well was operating, resulting in lower flow to the system.
- (c) Calculated based on 49 ft<sup>3</sup> of media in the system.
- (d) “+” indicates the reading was past the highest value that could be read on the gauge
- (e) Pressure loss across the entire system.
- (f) Number in parenthesis is the average number of days between backwashes during the period from 02/09/04 through 08/13/04.
- NA = not applicable.

During the first six months, the APU-100 system treated approximately 7,158,000 gallons of water (19,503 bed volumes) based on totalizer readings from each vessel. Bed volume calculations are based on a total bed volume of 49 ft<sup>3</sup> rather than 52 ft<sup>3</sup>. This revised bed volume was estimated based on information provided by the vendor that 3 ft<sup>3</sup> of media was lost from Vessel A during the initial system backwash and media conditioning performed in late January 2004. The average flowrate to the system was 82 gpm with a relatively balanced split between Vessel A and Vessel B. The range of flowrates to each vessel was 19-62 gpm and 25-63 gpm in Vessels A and B, respectively. The average flowrate and range of flowrates shown in Table 4-4 include periods when only one supply well was operating, resulting in lower total flow to the system. Based on the wide range of flows to the system, the EBCT in the two vessels varied from 2.9 to 9.0 minutes.

**4.4.2 Differential Pressure.** The APU-100 system experienced elevated inlet pressure and higher than expected pressure drop across the treatment system. Figures 4-7 and 4-8 show a histogram of differential pressures for each vessel and total system flowrate. In multiple attempts to address these elevated pressure conditions, backwash was conducted repeatedly with flowrates up to 11 gpm/ft<sup>2</sup>, as recommended by the vendor. Each backwash event is noted on Figures 4-7 and 4-8. The aggressive backwashes did not

### Vessel A Differential Pressures

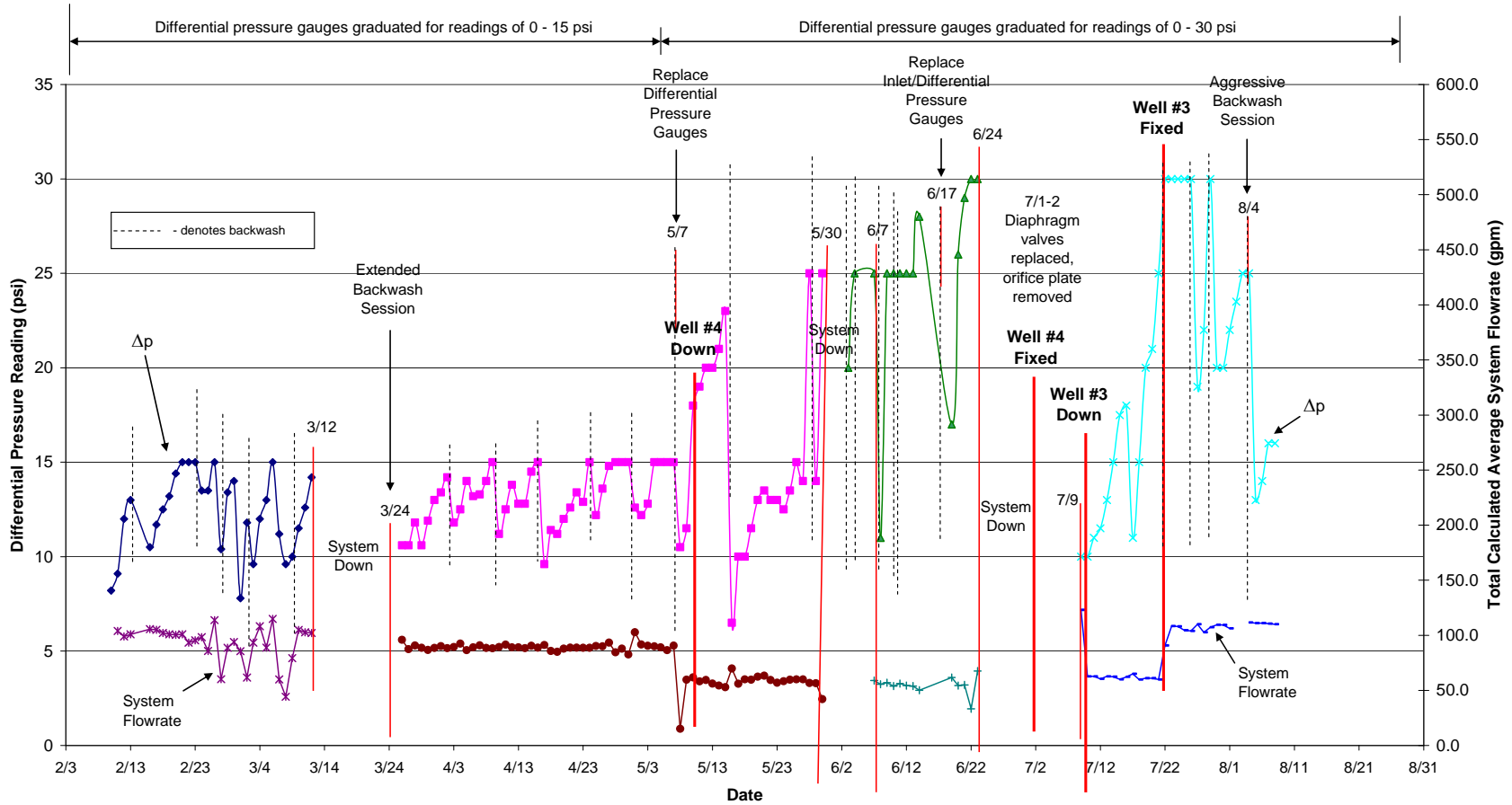

Figure 4-7. Differential Pressure Loss ( $\Delta p$ ) and System Flowrate Across Vessel A During the First Six Months of Operation



### Vessel B Differential Pressures

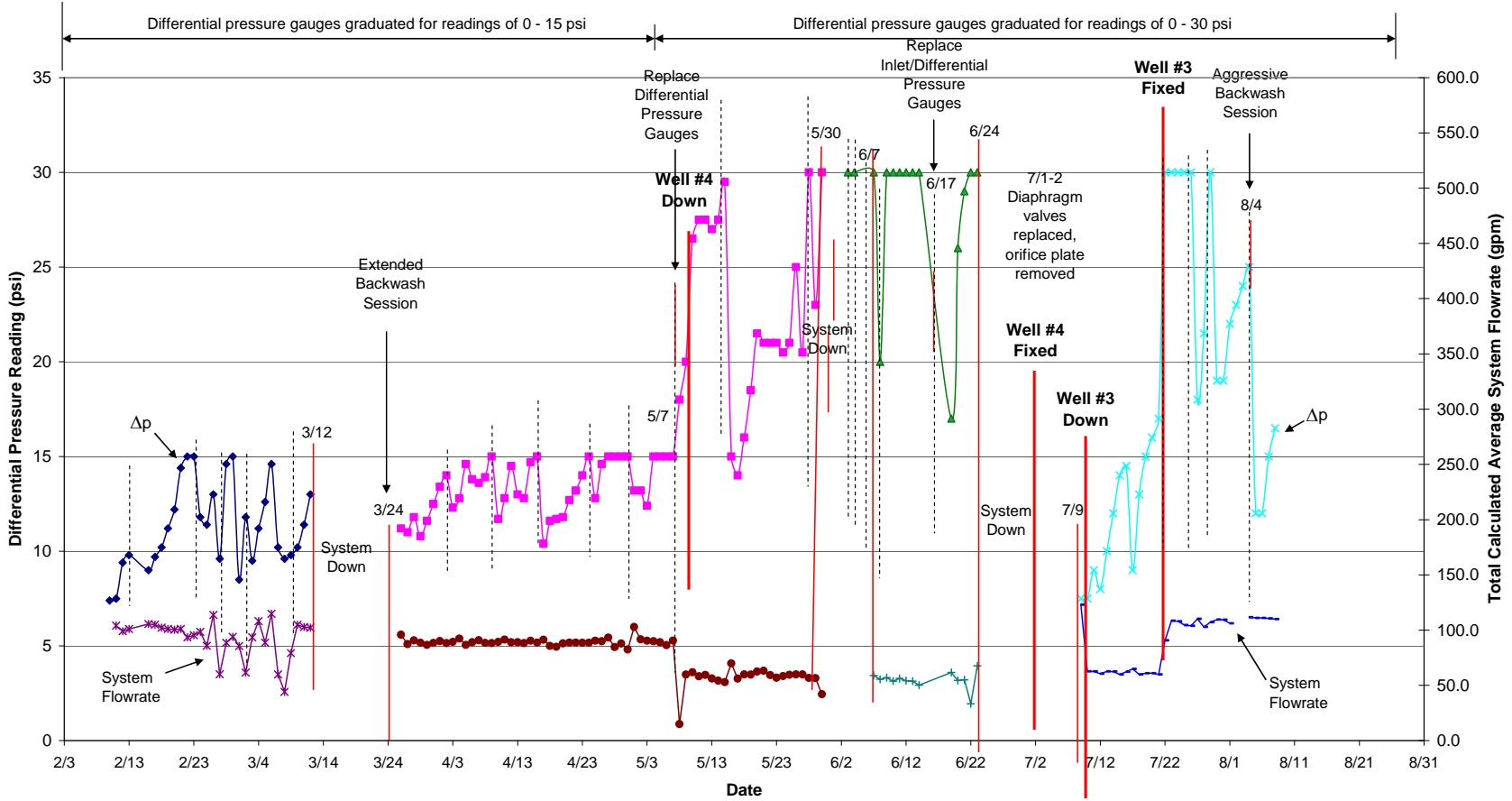

Figure 4-8. Differential Pressure Loss ( $\Delta p$ ) and System Flowrate Across Vessel B During the First Six Months of Operation

appear to be effective in resolving the elevated pressure problems. Additionally, there were periods when the system was bypassed due to the elevated pressure conditions at the system inlet. Extensive troubleshooting and replacement of several system components also were performed to address the problems encountered. The following is a brief summary of the differential pressure issues experienced.

Based on the system design, no more than 2-3 psi of pressure drop,  $\Delta p$ , would be expected across each vessel, and backwash would be performed when the  $\Delta p$  reached 10 psi. However, as shown in Figures 4-7 and 4-8,  $\Delta p$  consistently exceeded 10 psi for the majority of time the system operated.

During the first month of operation (from February 9 to March 12), the system was backwashed five times in response to the elevated  $\Delta p$  readings. Backwashes were initiated when the  $\Delta p$  reached 15 psi, which was the upper limit of the gauges originally installed on the system. The  $\Delta p$  returned to 10-11.5 psi following each backwash event. In order to extend the time between backwash events, the operator sometimes had to operate only one supply well to reduce the flowrate to the system, and reduce the inlet pressure and  $\Delta p$  levels in the system.

The vendor speculated at the time that the elevated  $\Delta p$  readings across the vessels were caused by media fines present at the laterals that had not been removed during the initial backwash. On March 24 and 25, a series of aggressive backwashes were performed at increased hydraulic loadings of 8-9 gpm/ft<sup>2</sup> (vs. 4-5 gpm/ft<sup>2</sup>, initially) in an attempt to remove the fines. The  $\Delta p$  readings immediately following the aggressive backwash were 9-9.5 psi. Upon being put back into service on March 26, the  $\Delta p$  readings were 10.6 and 11.2 psi in Vessel A and B, respectively. The readings rose to approximately 14 psi within one week of operation. For six weeks following the aggressive backwash, the system required backwashing weekly. The  $\Delta p$  returned to about 10-12 psi immediately after each backwash and climbed steadily to 15+ psi within one week.

On May 7, 2004, the differential pressure gauges were replaced with gauges that read up to 30 psi. On May 9, 2004, Well No. 4 went down and remained inoperable through July 2, 2004. Throughout the month of May, with only Well No. 3 operating and total system flowrates typically of 60 gpm or less, the system continued to experience elevated pressure conditions. On May 30, 2004, the system was shut down due to excessive pressure (more than 100 psi) at the inlet. During the next two weeks, the system was backwashed five times in an attempt to lower the inlet pressure and  $\Delta p$  levels.

On June 17, 2004, the vendor returned to the site to replace the inlet pressure gauge and the  $\Delta p$  gauges to ensure that the high pressure readings were not due to faulty gauges. While on site, the vendor also removed, cleaned, and inspected the variable diaphragm valves located upstream of each vessel for flow control. The diaphragm valves were determined to be in satisfactory condition and re-installed into the system. The system was put back into service on June 19 and the inlet pressure was observed to be lower at 80 psi. Within five days, the inlet pressure levels had again increased to over 90 psi and the  $\Delta p$  levels had again been above what the gauges were able to read at 30+ psi.

Due to the continuing high pressure conditions, the system was taken off-line between June 24 and July 9, 2004. The vendor returned to the site on July 1 and 2 to replace the diaphragm valves with simple non-actuated valves. The orifice plates that controlled and balanced the flows to the vessels also were removed from the discharge side of the vessels to help eliminate flow restrictions. After it was put back online on July 9, 2004, the system operated at lower pressure for a short while. The pressures began to steadily rise over the week of July 12, 2004 and by July 22, 2004 were back to the same levels (~100 psi at the inlet and 30+ psi  $\Delta p$  across each vessel) as before. During the period of July 10 through July 22, 2004, Well No. 3 was down and not operating. (Note that as mentioned above, Well No. 4 was down during the period May 9 to July 2, 2004. Well No. 3 went down 8 days after Well No. 4 was fixed.) The

elevated  $\Delta p$  conditions seen during the period when Well No. 3 was inoperable were at reduced flowrates of approximately 60 gpm. After Well No. 3 was back in service on July 22, 2004, the inlet pressure went to 100+ psi and the  $\Delta p$  for both vessels went to 30+ psi, exceeding the measurable pressure on all three gauges.

The system operated under similar conditions for the next eight days before being bypassed again on August 2, 2004. On August 4, the vendor returned to the site to retrofit the system with a larger diameter (2-inch vs. 1-inch, originally) backwash flowmeter to allow for an even more aggressive backwash at 10-11 gpm/ft<sup>2</sup>. Following this backwash, the  $\Delta p$  reading fell to 12-13 psi across each vessel, and the inlet pressure was recorded at 76 psi.

As of the end of the six-month evaluation period, close monitoring of the system operational parameters continued in order to assess the effectiveness of the aggressive backwash.

**4.4.3 CO<sub>2</sub> Injection.** As described in Section 4.2, pH adjustment using a CO<sub>2</sub> injection module was a process component. This module also experienced operational irregularities during the first 6 months of the demonstration study. First, leaks were detected in the CO<sub>2</sub> system resulting in frequent change-outs of the CO<sub>2</sub> gas cylinders during the first few weeks of the system operation. Second, the CO<sub>2</sub> injection module was not functioning properly, which was caused by a broken gas regulator and damaged O-rings located at the CO<sub>2</sub> injection point. Following maintenance, the CO<sub>2</sub> system operated more consistently by maintaining pressure and requiring regular change-outs about every 2-3 weeks.

Besides the mechanical problems, the CO<sub>2</sub> system failed to consistently adjust the pH to the target value of 7.0 with the pH values measured by the inline pH probe varying between 4.70 and 9.05. However, the average pH reading from the inline probe was 6.94, which was just slightly below the target value of 7.0.

The accuracy of the CO<sub>2</sub> system to control the incoming pH was another problem issue as noted by the differences between the pH readings measured by the inline pH probe and those by a laboratory pH probe (with samples taken from the AP [after pH adjustment] sampling location). As shown in Table 4-5, the readings from the inline probe varied from 4.70 to 9.05, while the readings from the laboratory pH probe were about 0.1 to 0.6 pH units higher than the target pH value of 7.0. Some of the variation in the inline readings was thought to be attributed to manual adjustments to the CO<sub>2</sub> gas flowrate, although a similar swing should have been observed in the AP readings. Another possible explanation for the variations might be degassing of dissolved CO<sub>2</sub> from water samples collected from the AP location, thus resulting in elevated readings measured by the laboratory probe. Further, buildup of a white film on the probe, first observed near the end of April, also might affect the inline probe performance, as elevated pH readings (see Table 4-5, inline probe readings for April 19 and April 29) were recorded during this period. Following cleaning, the probe reading returned to below 6.8 on May 7. Since then, the probe was removed every one to two weeks for regular cleaning.

**4.4.4 Backwash.** AdEdge recommended that the APU treatment system be backwashed, either manually or automatically, approximately once per month. Automatic backwash could be initiated either by timer or by differential pressure in the vessels. However, due to the ongoing elevated  $\Delta p$  and inlet pressure problems (see Section 4.4.2), the APU-100 system was backwashed far more frequently than was originally anticipated. Backwash has been conducted only on a manual basis. The system was backwashed 25 times during the first 27 weeks of operation, with the interval between two consecutive backwash events varying between 1 and 19 days (see Table 4-4).

As discussed in Section 4.4.2, in an attempt to address the elevated pressure issues, the backwash flowrate was increased from 30-35 gpm (or approximately 4-5 gpm/ft<sup>2</sup>) to 55-65 gpm (or 8-9 gpm/ft<sup>2</sup>) in late

**Table 4-5. Summary of pH Readings Recorded at the AP Sample Location and the Inline pH Probe**

<b>Date</b>	<b>pH Reading at AP Sample Location</b>	<b>pH Reading by Inline pH Probe</b>	<b>Difference</b>
01/30/04	7.30	–	–
02/16/04	6.82	7.26	–0.44
02/24/04	7.38	6.81	0.57
03/02/04	7.54	6.49	1.05
03/10/04	7.48	7.05	0.43
04/06/04	7.50	6.51	0.99
04/13/04	7.34	7.04	0.30
04/19/04	7.16	9.05	–1.89
04/29/04	7.12	8.08	–0.96
05/07/04	7.58	6.77	0.81
05/18/04	7.48	6.50	0.98
05/25/04	7.46	4.70	2.76
06/09/04	7.01	7.07	–0.06
07/13/04	NM	7.38	–
07/20/04	7.22	7.72	–0.50
08/04/04	7.64	6.20	1.44
08/10/04	7.37	7.37	0.00

March 2004, and then to 75-77 gpm (or 10-11 gpm/ft<sup>2</sup>) following system retrofit with a larger diameter backwash flowmeter. Depending on the flowrate, a single 20-minute backwash cycle for one vessel produced between 600 and 1,500 gallons of water. Based on the backwash log sheet recorded by the operator, approximately 60,000 gallons of backwash water were generated from the 25 backwash events conducted during this period.

**4.4.5 Residual Management.** Residuals produced by the operation of the APU-100 system included backwash water and spent media. The media was not replaced during the first six months of system operation; therefore, the only residual produced was backwash water. Piping for backwash water from both vessels is combined aboveground inside the treatment building before exiting the building through the floor. The pipe then travels underground to a subsurface drainage structure located in the parking area in front of the treatment building. The backwash water then infiltrates to the ground from this disposal structure. Any particulates or fines carried in the backwash water remain in the drainage structure.

**4.4.6 System/Operation Reliability and Simplicity.** The operational issues related to the elevated  $\Delta p$  and inlet pressure and the operation of the CO<sub>2</sub> injection system were the primary factors affecting system reliability and operation simplicity.

Unscheduled downtime during the first six months of system operation was caused by the needs to address the elevated pressures and operational problems with the CO<sub>2</sub> injection system. As described in Section 4.4.3, the system was bypassed between March 12 to March 26, 2004 due to some damaged parts in the CO<sub>2</sub> injection system. Unscheduled downtime due to the elevated inlet pressure and  $\Delta p$  issues occurred from May 30 through June 2, June 5 and 6, June 16 through 18, June 24 through July 9, and August 2, 2004. During the first 185 days of operation, the system was down for a total of 39 days, resulting in an operational efficiency of 78%.

The simplicity of system operation and operator skill requirements are discussed below in relation to pre- and post-treatment requirements, levels of system automation, operator skill requirements, preventive maintenance activities, and frequency of chemical/media handling and inventory requirements.

***Pre- and Post-Treatment Requirements.*** Initially, the only pre-treatment performed at this site was pH adjustment using CO<sub>2</sub> injection. The raw water (IN) sample tap was re-located further upstream of the CO<sub>2</sub> injection point in late March 2004 to avoid possible influence by the CO<sub>2</sub> injection. During the first one and a half months of operation, chlorine addition was added at the end of the treatment train to provide chlorine residual as was performed prior to the arsenic demonstration study. In March 2004, total arsenic levels in the treated water measured as high as 7.7 µg/L, much earlier than projected by the vendor, and the majority of arsenic passing through the AD-33 media was As(III). In late March 2004, the chlorination point was moved upstream of the APU treatment vessels and after the CO<sub>2</sub> injection point to oxidize As(III) to As(V) and improve arsenic removal efficiency. Post-chlorination was not required because up to 0.05 mg/L (as Cl<sub>2</sub>) free chlorine residual remained in the treated water before entering the distribution system.

***System Automation.*** The APU-100 system was fitted with automated controls that would allow for the backwash cycle to be controlled automatically; however, due to the pressure problems these automated controls were not used during the first six months of system operation.

***Operator Skill Requirements.*** Under normal operating conditions, the skill requirements to operate the APU-100 system were minimal. The daily demand on the operator was typically 15-20 minutes to perform daily checks of the system, visual inspection, and record the system operating parameters on the daily log sheets. Normal operation of the system did not appear to require additional skills beyond those necessary to operate the existing water supply equipment. On days when the system was backwashed, the operator typically spent approximately two hours on site to complete this process.

Due to the  $\Delta p$  and elevated inlet pressure problems, the operator spent much more time troubleshooting the operation of the treatment system than would normally be expected. As requested by the vendor, the operator conducted backwash far more frequently than originally anticipated and worked with the vendor to troubleshoot, modify, and replace several system components. The majority of the labor to modify or replace system components was performed by the installation subcontractor hired by the vendor; however, all of the additional visits and coordination of additional work required the plant operator to be on site on several occasions for periods of two to four hours or more, depending on the type of work being conducted.

***Preventive Maintenance Activities.*** Preventive maintenance tasks included such items as periodic checks of the flowmeters and pressure gauges and inspection of system piping and valves. As mentioned in Section 4.4.3, weekly cleaning of the inline pH probe was found to be necessary to remove the buildup of a film on the probe. The vendor suggested inspection of the vessel internals, including adsorber laterals and replacement of the underbedding gravel during media replacement. Due to the operational issues that existed, the operator spent additional time at the site troubleshooting and working with AdEdge technicians during their return visits to the site. Typically the operator was on site an additional 30 minutes to as much as two to three hours per week working to address these issues. Under normal operation, it is not expected that this additional time would be required.

***Chemical/Media Handling and Inventory Requirements.*** The only chemicals required for the system operation included the sodium hypochlorite solution used for chlorination, which was already in use at the site, and the CO<sub>2</sub> gas cylinders used for the pH adjustment. The CO<sub>2</sub> cylinders required change-out typically once every two to three weeks, and the 50-gallon drum of 4% chlorine solution required refilling once every two to three weeks.

## 4.5 System Performance

The performance of the APU-100 system was evaluated based on analyses of water samples collected from the treatment plant, the system backwash, and the distribution system.

**4.5.1 Treatment Plant Sampling.** Samples were collected at five locations through the treatment process: the inlet (IN), after pH adjustment and prechlorination (AP), at the effluent of Vessels A and B (TA and TB, respectively), and at the combined effluent (TT). Field-speciated samples at IN, AC, and TT were collected once every four weeks throughout this reporting period. Table 4-6 summarizes the analytical results of critical constituents including arsenic, iron and manganese concentrations measured at the five sampling locations through the treatment train. Table 4-7 summarizes the results of other water quality parameters. Appendix B contains a complete set of analytical results through the first six months of operation. The results of the water samples collected throughout the treatment plant are discussed below.

**Artenic.** The key parameter for evaluating the effectiveness of the APU-100 was the concentration of arsenic in the treated water. During the first one and a half months of operation, chlorine was added at the end of the treatment train following the APU-100 adsorption system. In March 2004, total arsenic levels in the treated water, existing primarily as As(III), increased to as high as 7.7 µg/L after only about 2,700 bed volumes of water had been treated. In late March 2004, to improve arsenic removal by the media, prechlorination was implemented. The analytical results shown in Tables 4-6 and 4-7 include only the results collected after the switch to prechlorination. Since then, water samples were collected on 16 occasions with field speciation performed on four occasions. Raw water from the IN location was sampled at each of the 16 sampling events. AP was sampled 15 times, TA and TB 12 times, and TT was sampled 4 times.

Figure 4-9 contains three bar charts showing the concentrations of total arsenic, particulate arsenic, As(III), and As(V) at the IN, AP, and TT locations for each sampling event. Total arsenic concentrations in raw water ranged from 28.7 to 46.6 µg/L and averaged 39.3 µg/L. Particulate arsenic concentrations averaged 4.3 µg/L. Typically, As (III) was slightly higher than As(V), with As(III) averaging 20.8 µg/L and As(V) averaging 13.7 µg/L. The arsenic concentrations measured were consistent with raw water samples collected previously during the source water sampling at this site (Table 4-1).

The pre-treatment step (including chlorination and pH adjustment) oxidized As(III) to As(V), lowered the pH of the incoming raw water, and provided the required chlorine residual to the distribution system. After switching to prechlorination, samples collected downstream of the chlorine injection/pH adjustment point (AP) had average As(III) and As(V) concentrations of 0.6 and 33.2 µg/L, respectively. Analytical results for As(III) and As(V) were not available from the AP sampling location for the March 9, 2004 sample, so only the soluble and particulate concentrations are shown in Figure 4-9 for that date.

Free and total chlorine were monitored at the AP and TT sampling locations to ensure that the target chlorine residual levels were properly maintained. Free chlorine measurements at the AP and TT locations ranged from 0.04 to 0.40 mg/L and total chlorine levels ranged from 0.20 to 0.71 mg/L (Table 4-7). The residual chlorine measured at the TT location was very similar to that measured at the AP location, indicating little or no chlorine consumption through the AD-33 media.

After switching to prechlorination, total arsenic concentrations at the combined treated water sample location (TT) ranged from 2.4 to 20.3 µg/L (Table 4-6). As shown in Figure 4-10, breakthrough of total arsenic at concentrations above the 10 µg/L target level were first observed at 12,500 bed volumes during the May 25, 2004 sampling event. Arsenic concentrations returned to below 10 µg/L at the TA/TB locations the following week, but increased to over 10 µg/L again at the TA location on June 22. The system

**Table 4-6. Summary of Critical Analytical Results after Relocation of Chlorination Point  
Upstream of Adsorption Vessels**

Parameter	Sampling Location <sup>(a)</sup>	Units	Number of Samples	Minimum Concentration	Maximum Concentration	Average Concentration	Standard Deviation
As (total)	IN	µg/L	16	28.7	46.3	38.2	4.7
	AP	µg/L	15	30.0	75.2	43.3	10.5
	TA	µg/L	12	2.1	17.2	6.4	4.2
	TB	µg/L	12	1.7	21.9	6.5	5.6
	TT	µg/L	4	2.4	20.3	8.5	8.0
As (total soluble)	IN	µg/L	4	29.8	35.7	33.2	2.9
	AP	µg/L	3	30.7	35.5	33.8	2.7
	TT	µg/L	4	2.1	19.1	7.8	7.6
As (particulate)	IN	µg/L	4	0.3	6.2	3.8	2.8
	AP	µg/L	3	0.1	7.1	3.9	3.6
	TT	µg/L	4	0.1	1.2	0.6	0.5
As (III)	IN	µg/L	4	12.4	25.8	18.3	5.6
	AP	µg/L	3	0.5	0.8	0.6	0.2
	TT	µg/L	4	0.4	0.8	0.6	0.2
As (V)	IN	µg/L	4	4.0	19.2	14.8	7.3
	AP	µg/L	3	30.2	34.8	33.2	2.6
	TT	µg/L	4	1.5	18.3	7.3	7.5
Fe (total)	IN	µg/L	16	37.1	489.1	156.4	115.6
	AP	µg/L	15	< 25	898.2	255.8	242.5
	TA	µg/L	12	< 25	131.0	24.0	34.2
	TB	µg/L	12	< 25	280.0	36.2	76.9
	TT	µg/L	4	< 25	< 25	< 25	0.0
Fe (dissolved)	IN	µg/L	4	< 25	183.0	59.2	82.9
	AP	µg/L	3	< 25	< 25	< 25	0.0
	TT	µg/L	4	< 25	< 25	< 25	0.0
Mn (total)	IN	µg/L	16	51.9	245.0	114.0	58.2
	AP	µg/L	15	59.5	241.0	115.7	50.7
	TA	µg/L	12	0.6	24.2	7.2	6.7
	TB	µg/L	12	1.1	65.3	9.1	18.1
	TT	µg/L	4	0.6	1.6	1.2	0.5
Mn (dissolved)	IN	µg/L	4	48.9	235.0	119.8	81.0
	AP	µg/L	3	50.2	104.9	74.9	27.7
	TT	µg/L	4	0.6	1.9	1.1	0.6

(a) See Figure 4-3.

One-half of the detection limit was used for samples with concentrations less than the detection limit for calculations.

Duplicate samples were included in the calculations.

Only samples collected after the switch to prechlorination, beginning with the sample collected on March 30, 2004, are included.

**Table 4-7. Summary of Water Quality Parameter Sampling Results after Relocation of Chlorination Point Upstream of Adsorption Vessels**

Parameter	Sampling Location <sup>(a)</sup>	Units	Number of Samples	Minimum Concentration	Maximum Concentration	Average Concentration	Standard Deviation
Alkalinity	IN	mg/L	16	164	259	190	25
	AP	mg/L	15	162	236	185	22
	TA	mg/L	12	160	219	182	17
	TB	mg/L	12	163	207	181	13
	TT	mg/L	4	160	196	181	16
Fluoride	IN	mg/L	4	0.5	0.6	0.6	0.1
	AP	mg/L	3	0.6	0.6	0.6	0.0
	TT	mg/L	4	0.5	0.6	0.6	0.1
Sulfate	IN	mg/L	4	35	72	48	17
	AP	mg/L	3	33	46	40	7
	TT	mg/L	4	33	80	48	21
Orthophosphate (as PO <sub>4</sub> )	IN	mg/L	15	< 0.10	0.12	0.1	0.02
	AP	mg/L	14	< 0.10	0.12	0.1	0.02
	TA	mg/L	11	< 0.10	< 0.10	< 0.10	0.00
	TB	mg/L	11	< 0.10	< 0.10	< 0.10	0.00
	TT	mg/L	4	< 0.10	< 0.10	< 0.10	0.00
Silica	IN	mg/L	16	13.6	16.1	14.8	0.7
	AP	mg/L	15	13.7	16.5	14.8	0.7
	TA	mg/L	12	13.8	15.4	14.9	0.4
	TB	mg/L	12	13.5	15.7	14.9	0.6
	TT	mg/L	4	13.9	15.3	14.5	0.6
Nitrate (as N)	IN	mg/L	4	< 0.04	< 0.08	< 0.04	0.00
	AP	mg/L	3	< 0.04	< 0.08	< 0.04	0.00
	TT	mg/L	4	< 0.04	< 0.08	< 0.04	0.00
Turbidity	IN	NTU	16	0.4	36.0	5.1	10.8
	AP	NTU	15	0.3	14.0	2.0	3.4
	TA	NTU	12	0.3	7.4	1.4	2.0
	TB	NTU	12	0.4	13.0	1.8	3.6
	TT	NTU	4	0.2	1.3	0.6	0.5
pH	IN	S.U.	12	7.4	8.2	7.9	0.2
	AP	S.U.	11	7.0	7.6	7.4	0.2
	TA	S.U.	8	7.1	7.7	7.4	0.2
	TB	S.U.	8	7.1	7.6	7.4	0.2
	TT	S.U.	4	6.9	8.0	7.5	0.5
Temperature	IN	°C	12	10.1	19.5	14.2	2.6
	AP	°C	11	8.9	17.7	13.5	2.4
	TA	°C	8	9.0	16.4	13.5	2.3
	TB	°C	8	9.1	17.5	13.7	2.5
	TT	°C	4	10.7	15.0	13.3	1.9
Dissolved Oxygen	IN	mg/L	12	2.0	5.4	3.8	0.9
	AP	mg/L	11	2.4	4.3	3.4	0.7
	TA	mg/L	8	1.9	3.9	3.0	0.7
	TB	mg/L	8	2.2	4.1	3.1	0.7
	TT	mg/L	4	2.0	2.2	2.1	0.1



**Table 4-7. Summary of Water Quality Parameter Sampling Results after Relocation of Chlorination Point Upstream of Adsorption Vessels (Continued)**

Parameter	Sampling Location <sup>(a)</sup>	Units	Number of Samples	Minimum Concentration	Maximum Concentration	Average Concentration	Standard Deviation
ORP	IN	mV	12	-66	-7	-49	19
	AP	mV	11	-50	1	-26	14
	TA	mV	8	-41	-2	-22	13
	TB	mV	8	-43	-3	-22	14
	TT	mV	4	-50	-1	-30	21
Free Cl <sub>2</sub>	AP	mg/L	7	0.05	0.40	0.17	0.13
	TT	mg/L	2	0.04	0.05	0.05	0.01
Total Cl <sub>2</sub>	AP	mg/L	7	0.20	0.71	0.45	0.19
	TT	mg/L	2	0.23	0.26	0.25	0.02
Total Hardness (as CaCO <sub>3</sub> )	IN	mg/L	3	54.1	62.7	57.2	4.8
	AP	mg/L	3	53.9	68.1	58.8	8.1
	TT	mg/L	3	54.7	79.6	66.3	12.5

(a) See Figure 4-3.

One-half of the detection limit was used for samples with concentrations less than the detection limit for calculations.

Duplicate samples were included in the calculations.

Only samples collected after the switch to prechlorination, beginning with the sample collected on March 30, 2004, are included.

was bypassed from June 24 and July 9, 2004 due to the elevated pressure problems. Samples of treated water collected on July 13 and July 22 were again below 10 µg/L; however, the concentrations were above 10 µg/L on July 29 and August 4, 2004. Based on this data, breakthrough of arsenic at 10 µg/L occurred somewhere between 12,500 and 15,000 bed volumes representing about 15 to 20% of the estimated working capacity of 74,000 bed volumes (see Table 4-3).

As expected, Figure 4-10 shows a close similarity in total arsenic concentrations at the IN and AP locations, and similarly reduced concentrations at the outlet of each vessel (TA and TB) and the combined outlet (TT). The total arsenic concentration measured at the AP location on June 8, 2004 (about 13,500 bed volumes) and at the TT location on May 25, 2004 (about 12,500 bed volumes) were unusually high at 75.2 and 20.3 µg/L, respectively. It was not clear why these concentrations were higher than the other relevant data points.

**Iron.** Total iron concentrations at the inlet (IN) ranged from 37.1 to 489.1 µg/L with an average of 156.4 µg/L. Iron concentrations following pH adjustment and prechlorination (AP) ranged from <25 to 898.2 µg/L with an average concentration of 255.8 µg/L. Total iron from the effluent of the adsorption vessels (TA and TB) ranged from less than detect (<25 µg/L) to 280.0 µg/L with an average of 24.0 and 36.2 µg/L at TA and TB, respectively. Following the switch to prechlorination, however, the iron concentrations in the treated water were almost always less than the detection limit. Dissolved iron levels ranged from <25 to 183 µg/L at the inlet (IN), and were always <25 µg/L at the AP and TT locations. These data indicate that the majority of iron entering the adsorption vessels existed in particulate form, and that the iron particles were captured by the media beds.

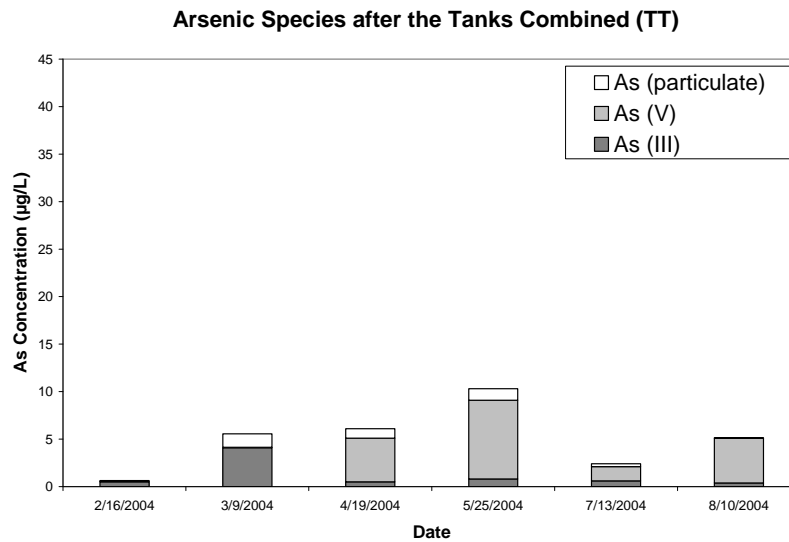
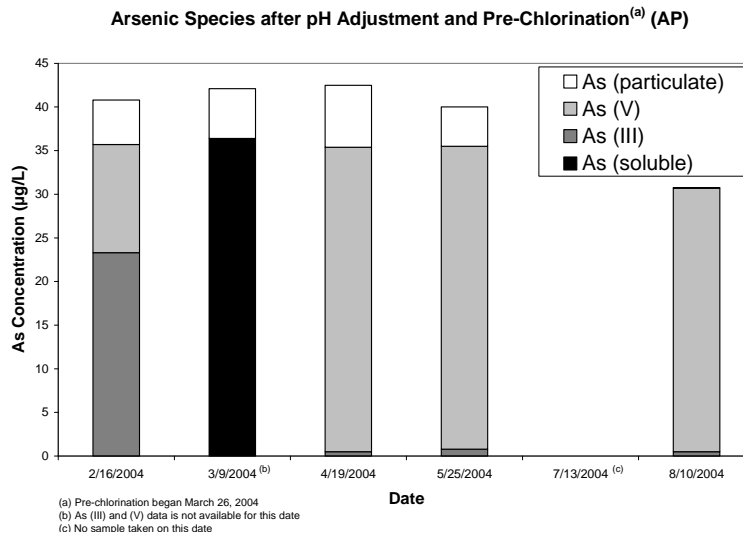
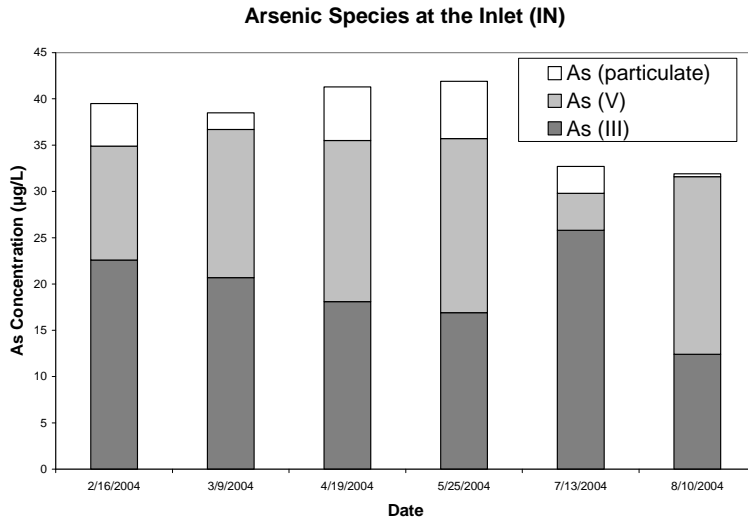

**Figure 4-9. Concentration of Arsenic Species at the IN, AP, and TT Sample Locations**

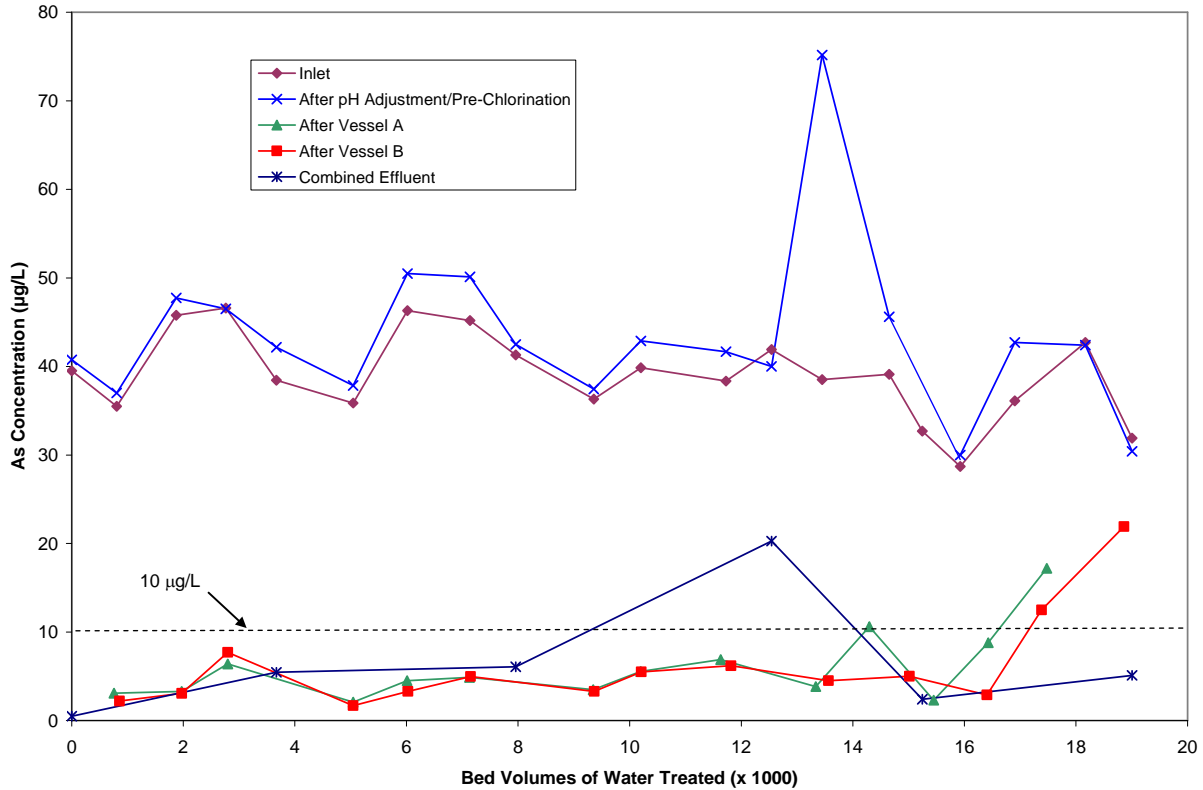

**Figure 4-10. Total Arsenic Breakthrough Curve**

**Manganese.** The treatment plant water samples were analyzed for total manganese at each sampling event and soluble manganese only during speciation sampling. Total manganese concentrations at the various sampling locations are plotted over time in Figure 4-11. Total and soluble manganese concentrations are shown in Figure 4-12. Influent total manganese levels ranged from 51.9 to 245.0 µg/L and averaged 114.0 µg/L (Table 4-6), with the majority of manganese present in the soluble form. In contrast to complete iron precipitation, chlorination precipitated less than 20% of soluble manganese before water entered the adsorption vessels. This observation was consistent with previous findings that free chlorine was relatively ineffective at oxidizing Mn(II) at pH values less than 8.0 to 8.5 (Knocke et al., 1987 and 1990). Total manganese concentrations at the TA, TB, and TT locations were typically reduced to <10 µg/L, indicating removal of manganese within the adsorption vessels. Prior to the switch to prechlorination, manganese quickly broke through the AD-33 adsorbents and reached about 100% breakthrough after only about 3,700 bed volumes. Knocke et al. (1990) reported that the presence of free chlorine in the filter promoted Mn(II) removal on MnO<sub>x</sub>-coated media; and that in the absence of free chlorine, Mn(II) removal was by adsorption only. Apparently, AD-33 media had a limited capacity for Mn(II) in the absence of free chlorine. After switching to prechlorination, the presence of chlorine promoted the removal of manganese on the AD-33 surface, probably via a mechanism similar to that proposed by Knocke on MnO<sub>x</sub>-coated media.

**Other Water Quality Parameters.** In addition to arsenic analyses, other water quality parameters were analyzed to provide insight into the chemical processes occurring within the treatment system. The results of the water quality parameters are included in Appendix B, and are summarized in Table 4-7.

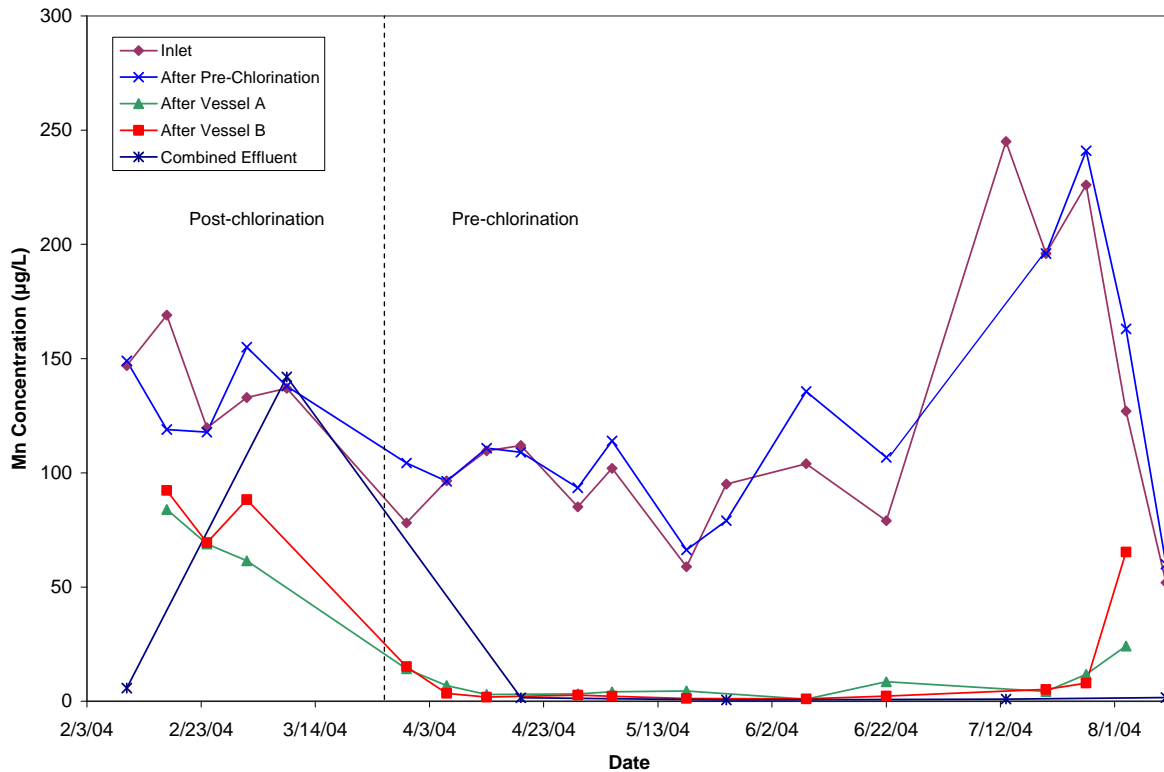

**Figure 4-11. Total Manganese Concentrations over Time**

pH values of the raw water measured at the IN sample location varied from 7.0 to 8.2 with the lowest reading of 7.0 measured twice in a row soon after the system began operation. After the IN sampling location was relocated about 6 ft farther upstream from the CO<sub>2</sub> injection point, the lowest pH reading recorded was 7.4. Following the CO<sub>2</sub> injection, the pH values at the AP sample location ranged from 7.0 to 7.6 with an average reading of 7.4. As noted in Section 4.4.3, the readings at the AP sample location were not consistent with those measured by the inline probe used to regulate CO<sub>2</sub> gas injection. Possible explanations for the differences were provided in Section 4.4.3. pH values recorded from the treated water sampling locations (TA, TB, TT) ranged from 6.9 to 8.0 with an average of 7.4 to 7.5. pH values at the various sampling locations throughout the treatment train are plotted versus time in Figure 4-13.

Sulfate concentrations ranged from 33 to 80 mg/L, and remained constant throughout the treatment train. Alkalinity, measured as CaCO<sub>3</sub>, ranged from 160 to 259 mg/L. The results indicate that the alkalinity was not affected by the prechlorination or the media. The treatment plant samples were analyzed for hardness only on speciation weeks. Total hardness ranged from 53.9 to 79.6 mg/L as CaCO<sub>3</sub>, and also remained constant throughout the treatment train.

Fluoride results ranged from 0.5 to 0.6 mg/L in all samples. Fluoride was measured only during speciation weeks and did not appear to be affected by the AD-33 media. Orthophosphate was below or very near the detection limit of 0.10 mg/L for all samples. Silica (as SiO<sub>2</sub>) concentration ranged from 13.5 to 16.5 mg/L, and appeared unaffected by the prechlorination and media.

DO levels ranged from 1.9 to 5.4 mg/L and did not appear to be affected by the prechlorination or the media. ORP readings ranged from -66 to 1 mV across all sampling locations. ORP readings were consistently higher in the raw water sample collected at the IN sample location than the readings from

### Manganese at the Inlet (IN)

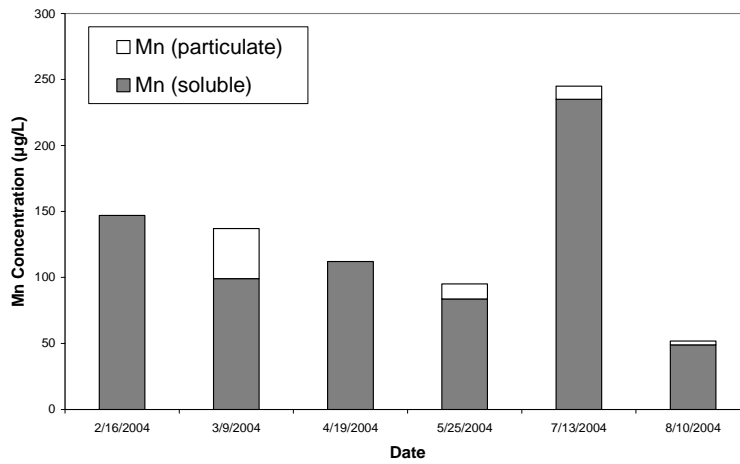

### Manganese after pH Adjustment and Pre-Chlorination<sup>(a)</sup> (AP)

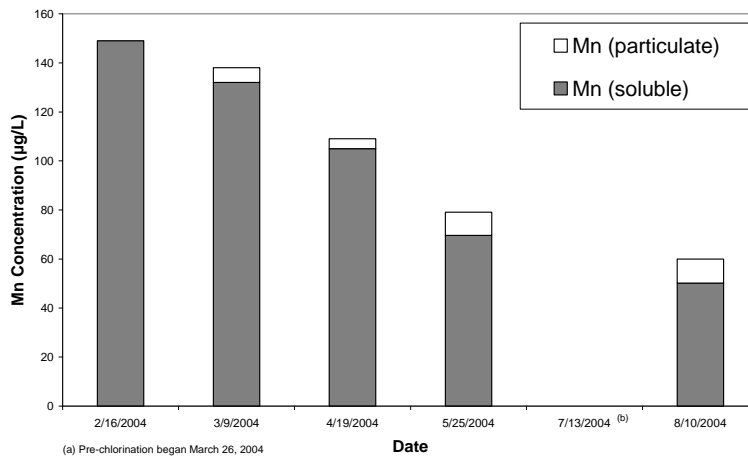

### Manganese after the Tanks Combined (TT)

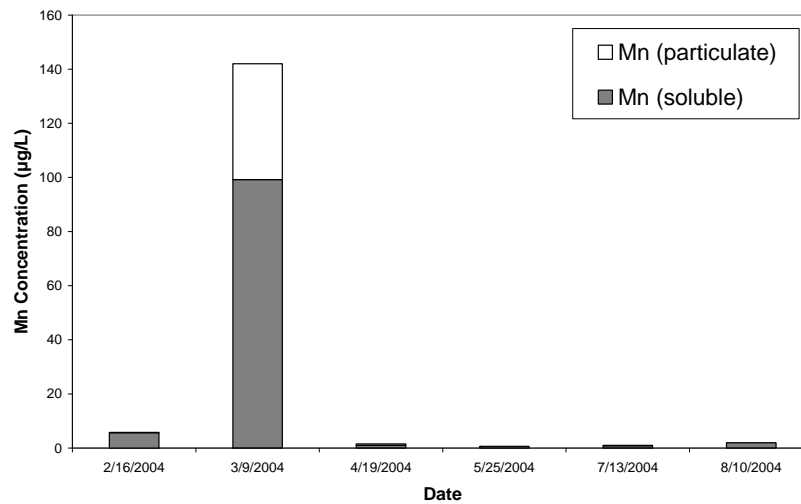

Figure 4-12. Concentration of Manganese Species at the IN, AP, and TT Sample Locations

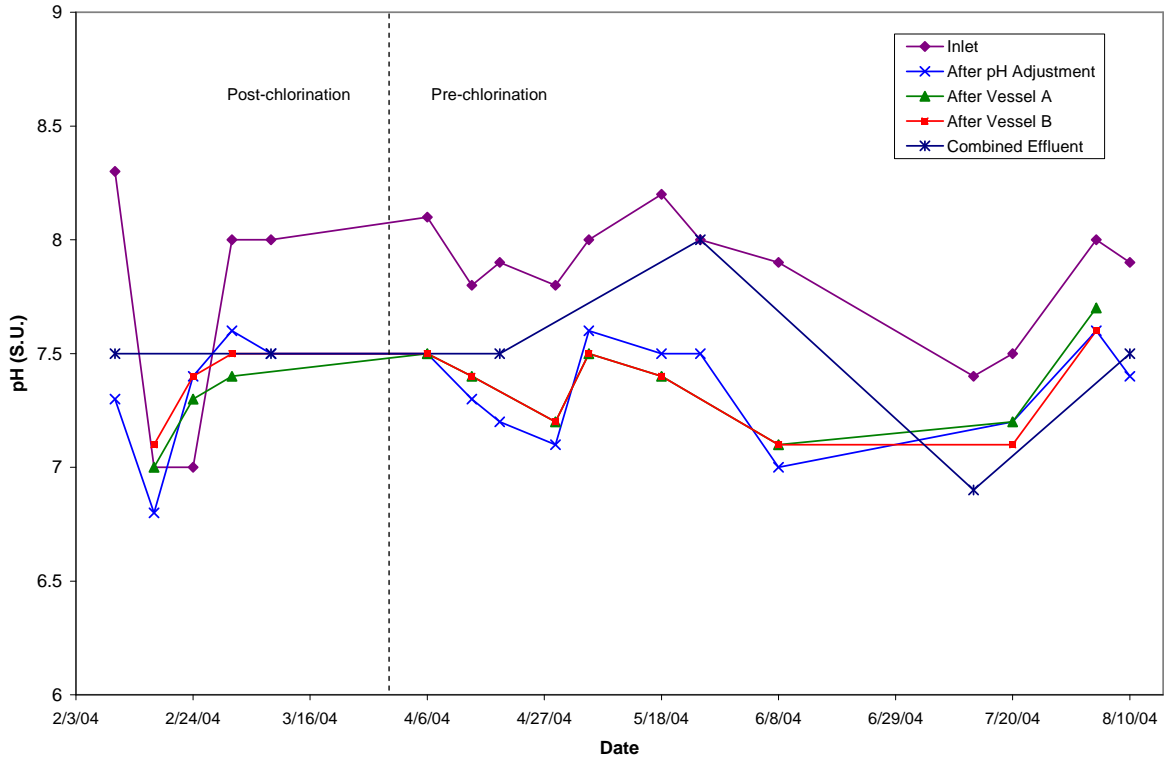

Figure 4-13. pH Values over Time

AP or the treated water samples. There did not appear to be a significant difference in the ORP readings between the AP samples and the treated water samples (TA, TB, TT), indicating that the AD-33 media did not have an effect on the ORP value.

**4.5.2 Backwash Water Sampling.** Backwash water was sampled on April 26, June 8, and July 22, 2004. Samples were collected from the sample ports located in the backwash effluent discharge lines from each vessel. The backwash was performed using raw water (non-chlorinated). The unfiltered samples were analyzed for pH, turbidity, and TDS/TSS. Filtered samples using 0.45- $\mu\text{m}$  disc filters were analyzed for soluble arsenic, iron, and manganese. In most cases, arsenic, iron, and manganese concentrations were lower than those in the raw water, indicating some removal of these metals by the media during backwash. Soluble arsenic concentrations in the backwash water ranged from 11.1 to 33.4  $\mu\text{g/L}$ . The analytical results from the three backwash water samples collected are summarized in Table 4-8.

Table 4-8. Backwash Water Sampling Results

Date	Vessel A						Vessel B					
	pH	Turbidity	TDS	As	Fe	Mn	pH	Turbidity	TDS	As	Fe	Mn
	-	mg/L	NTU	$\mu\text{g/L}$	$\mu\text{g/L}$	$\mu\text{g/L}$	-	NTU	mg/L	$\mu\text{g/L}$	$\mu\text{g/L}$	$\mu\text{g/L}$
4/26/2004 <sup>(a)</sup>	7.41	470	734	18.9	<25	20.9	7.42	360	308	21.8	<25	27.7
6/8/2004	7.15	110	320	21.3	<25	22.9	7.22	260	352	17.5	<25	12.5
7/22/2004	7.30	23	402	33.4	47	240.3	7.18	820	450	11.1	83	32.3

(a) Samples were analyzed for TSS rather than TDS.

**4.5.3 Distribution System Water Sampling.** Distribution system samples were collected to investigate if the water treated by the arsenic adsorption system would impact the lead and copper level and water chemistry in the distribution system. Prior to the installation/operation of the treatment system, baseline distribution water samples were collected on December 10, 2003 and January 6, and 21, 2004. Following the installation of the treatment system, distribution water sampling continued on a monthly basis at the same three locations, with samples collected on March 3, April 9, May 26, and July 27, 2004.

The samples were analyzed for pH, alkalinity, arsenic, iron, manganese, lead, and copper. Samples at the DS1 location were collected according to the procedures in EPA's Lead and Copper Rule (first draw samples). Both first draw and flushed samples were collected at the DS2 and DS3 locations which were non-residences.

Results of the distribution samples from all three locations following installation of the treatment system were similar to the results from the baseline sampling (Table 4-9). Copper levels did seem to fluctuate slightly more than the other metals analyzed, especially at the DS3 location; however, there was no discernable trend in any of the distribution sampling results collected. Based on this data, it appeared that the treatment system had little to no effect on the water quality in the distribution system. This was likely due to the fact that the distribution system in place was a looped system, combining water from Wells No. 3 and No. 4 at the Porter Well House, which typically operated at 100 gpm for about 10 hr/day, and was treated with the APU-100 system, with water produced from the General Sullivan Well, which typically operates at 80-100 gpm for about 12 hr/day, and was not treated (see Section 4.1). The blending of the treated water with the untreated water from General Sullivan might have masked any detectable effects of the APU-100 system on the water quality in the distribution system.

## **4.6 System Costs**

The cost-effectiveness of the system is evaluated based on the capital cost per gpm (or gpd) of the design capacity and the O&M cost per 1,000 gallons of water treated. The capital costs included equipment, engineering, and installation costs and O&M costs included media replacement and disposal, chemical supply, electrical power use, and labor.

**4.6.1 Capital Costs.** The capital investment costs for equipment, site engineering, and installation for the Rollinsford treatment system were \$106,568 (see Table 4-10). The equipment costs were \$82,081 (or 77% of the total capital investment), which included \$23,781 for the skid-mounted APU-100 unit, \$16,600 for the CO<sub>2</sub> injection module, \$13,230 for the AD-33 media (\$245/ft<sup>3</sup> or \$8.75/lb to fill two vessels), \$15,895 for miscellaneous materials required for installation, and \$12,575 for labor.

The engineering costs included the costs for the preparation of a process flow diagram of the treatment system, mechanical drawings of the treatment equipment, and a schematic of the building footprint and equipment layout to be used as part of the permit application submittal (see Section 4.3.1). The engineering costs were \$4,907, which was 5% of the total capital investment.

The installation costs included the equipment and labor to unload and install the skid-mounted unit and CO<sub>2</sub> injection loop and module, perform the piping tie-ins and electrical work, and load and backwash the media (see Section 4.3.3). The installation was performed by AdEdge and Waterline Services, a local contractor subcontracted by AdEdge to perform the installation. The installation costs were \$19,580, or 18% of the total capital investment.

Table 4-9. Distribution System Sampling Results

No. of Sampling Events	Address	DS1								DS2								DS3																							
		50 Water Street								Silver St. (Town Garage)								679 Main Street																							
		Non-LCR								Non-Residence								Non-Residence																							
		1st Draw								1st Draw				Flushed				1st Draw				Flushed																			
Sample Type	Flushed / 1st Draw	Stagnation Time (hrs)	pH	Alkalinity	As	Fe	Mn	Pb	Cu	Stagnation Time (hrs)	pH	Alkalinity	As	Fe	Mn	Pb	Cu	Stagnation Time (hrs)	pH	Alkalinity	As	Fe	Mn	Pb	Cu	Stagnation Time (hrs)	pH	Alkalinity	As	Fe	Mn	Pb	Cu								
BL1	12/10/2003	6.2	8.6	35	3.3	53	7.1	0.3	7.2	20.2	7.6	27	1.0	<25	4.8	6.2	70.7	NS	NS	NS	NS	NS	NS	NS	NS	20.2	7.6	27	3.5	108.0	13.0	0.9	289.8	NS	NS	NS	NS	NS	NS		
BL2	1/6/2004	6.0	7.67	41	3.9	100	8.5	1.4	200.0	14.3	6.9	29	0.6	<25	8.6	8.8	103.0	NA	7.58	31	0.5	<25	8.9	3.1	44.5	9.8	7.29	66	7.1	<25	6.5	2.2	326.0	NA	7.56	70	6.9	<25	6.3	0.5	328.0
BL3	1/21/2004	18.0	8.1	49	4.4	149	13.0	2.1	187.7	12 d	7.82	35	0.6	<25	8.0	1.2	95.6	NA	7.86	29	0.5	<25	7.9	0.6	41.5	14.5	7.83	31	2.7	<25	5.8	3.5	869.4	NA	7.76	146	24.9	93	62.8	1.5	109.7
1	3/3/2004	6.5	7.24	110	6.6	46	10.3	1.9	192.0	6 d	6.91	25	0.4	<25	6.3	3.6	77.2	NA	6.8	23	0.3	<25	6.5	0.5	12.4	14.5	6.95	88	5.6	<25	5.6	4.3	531.0	NA	7.52	157	9.9	<25	22.2	1.8	515.0
2	4/9/2004	7.0	7.84	98	6.7	<25	12.1	0.7	130.5	23.8 d	7.8	16	0.5	<25	9.2	1.5	148.1	NA	7.66	26	0.6	<25	8.1	0.3	22.8	14.8	7.6	90	8.8	<25	4.4	3.1	528.3	NA	7.64	115	8.3	<25	4.4	2.1	313.6
3	5/26/2004 <sup>(a)</sup>	6.0	NA	NA	3.0	74	8.9	1.2	192.0	9.5	NA	NA	0.5	<25	4.1	2.7	377 <sup>(a)</sup>	NA	NA	NA	0.4	<25	7.4	0.9	79.1	12.8	NA	NA	2.8	<25	4.1	9.4	830.0	NA	NA	NA	7.2	<25	2.8	2.3	463.0
4	7/27/2004 <sup>(b)</sup>	7.0	7.2	77	3.9	108	6.8	2.3	186.0	3.2 d	6.8	32	0.8	<25	7.2	7.4	61.5	NA	6.9	20	0.6	<25	8.8	0.9	31.2	13.8	NA	NA	6.0	<25	5.3	9.5	709.0	NA	7	99	13.2	<25	15.4	3.5	195.0

BL = baseline sampling

NS = not sampled

NA = not analyzed

(a) DS1 was sampled on May 27, 2004

(b) DS1 and DS3 were sampled on July 26, 2004

The unit for analytical parameters is µg/L except for alkalinity (mg/L as CaCO<sub>3</sub>)

Lead action level = 15 µg/L; copper action level = 1.3 mg/L



**Table 4-10. Capital Investment Costs for the APU-100 System**

Description	Quantity	Cost	% of Capital Investment Cost
<i>Equipment Costs</i>			
APU Skid-Mounted System	1 unit	\$23,781	–
AD-33 Media	54 ft <sup>3</sup>	\$13,230	–
Miscellaneous Equipment and Materials	–	\$15,895	–
pH Adjustment Module	1	\$16,600	–
Vendor Labor	–	\$12,575	–
<b>Equipment Total</b>	–	<b>\$82,081</b>	<b>77%</b>
<i>Engineering Costs</i>			
Material	–	\$75	–
Vendor Labor	–	\$3,800	–
Vendor Travel	–	\$1,032	–
<b>Engineering Total</b>	–	<b>\$4,907</b>	<b>5%</b>
<i>Installation Costs</i>			
Material	–	\$400	–
Subcontractor	–	\$14,850	–
Vendor Labor	–	\$3,040	–
Vendor Travel	–	\$1,290	–
<b>Installation Total</b>	–	<b>\$19,580</b>	<b>18%</b>
<b>Total Capital Investment</b>	–	<b>\$106,568</b>	<b>100%</b>

The Rollinsford Water and Sewer District constructed a new treatment building next to the existing Porter Well House. The wood frame structure measured 33 ft × 13 ft and has a concrete foundation and floor. The building cost was approximately \$57,000, including design and construction of the subsurface leach field directly adjacent to the building, used for disposing of the backwash water from the system.

The total capital cost of \$106,568 and equipment cost of \$82,081 were converted to a unit cost of \$0.14/1,000 gallons and \$0.10/1,000 gallons, respectively, using a capital recovery factor (CRF) of 0.06722 based on a 3% interest rate and a 20-year return period (Chen et al., 2004). These calculations assumed that the system operated 24 hours a day, 7 days a week at the system design flowrate of 100 gpm. The system operated only about 10 hours per day (see Table 4-4), producing 7,158,000 gallons of water during the six-month period, so the total unit cost and equipment-only unit cost increased to \$0.50/1,000 gallons and \$0.38/1,000 gallons, respectively, at this reduced rate of usage. Using the system's rated capacity of 100 gpm (144,000 gpd), the capital cost was \$1,066 per gpm of design capacity (\$0.74/gpd) and equipment-only cost was \$821 per gpm of design capacity (\$0.57/gpd). These calculations did not include the cost of the building construction.

**4.6.2 Operation and Maintenance Costs.** O&M costs include such items as media replacement and disposal, chemical supply, electricity, and labor. These costs are summarized in Table 4-11. Although not incurred during the first six months of system operation, the media replacement cost represented the majority of the O&M cost and was estimated to be \$16,810 to change out both vessels. This media change-out cost included costs for media, freight, labor, travel expenses, and media profiling and disposal fee. This cost was used to estimate the media replacement cost per 1,000 gallons of water treated as a function of the projected media run length to the 10 µg/L arsenic breakthrough (Figure 4-14).

**Table 4-11. Operation and Maintenance Costs for the APU-100 System**

<b>Cost Category</b>	<b>Value</b>	<b>Assumptions</b>
Volume processed (kgal)	7,158	Through August 13, 2004
<b>Media Replacement and Disposal</b>		
Media cost (\$/ft <sup>3</sup> )	\$245	Vendor quote
Total media volume (ft <sup>3</sup> )	44	Both vessels
Media replacement cost (\$)	\$10,780	Vendor quote
Under-bedding replacement cost (\$)	\$310	Vendor quote
Freight	\$440	Vendor quote
Labor cost (\$)	\$4,390	Vendor quote
Waste analysis	\$420	Vendor quote
Media disposal fee (\$)	\$470	Vendor quote
Subtotal	\$16,810	Vendor quote
Media replacement and disposal cost (\$/1,000 gal)	See Figure 4-14	Based upon media run length at 10-µg/L arsenic breakthrough
<b>Chemical Usage</b>		
CO <sub>2</sub> Cylinders(\$)	\$823	9 change-outs, delivery included
Chemical cost (\$/1,000 gal)	\$0.11	Cost for CO <sub>2</sub> only, no additional costs for chlorination included
<b>Electricity</b>		
Electricity cost (\$/1,000 gal)	\$0.001	Electrical costs assumed negligible
<b>Labor</b>		
Average weekly labor (hrs)	2.33	20 minutes/day
Labor cost (\$/1,000 gal)	\$0.18	Labor rate = \$20/hr
<b>Total O&amp;M Cost/1,000 gallons</b>	See Figure 4-14	Based upon media run length at 10-µg/L arsenic breakthrough

The chemical cost associated with the operation of the treatment system included the use of sodium hypochlorite for prechlorination and the CO<sub>2</sub> gas for pH adjustment. Sodium hypochlorite was already being used at the site prior to the installation of the APU-100 for disinfection purposes prior to distribution. The presence of the APU-100 system did not affect the use rate of the sodium hypochlorite solution. Therefore, the incremental chemical cost for chlorine was negligible. The CO<sub>2</sub> cylinders were replaced nine times during the first six months of system operation (approximately every two to three weeks). Each change-out costs \$91.45 and includes the replacement of two CO<sub>2</sub> cylinders and delivery charges. The CO<sub>2</sub> costs for the first six months of operation were calculated to be \$823 or \$0.11/1,000 gallons of water treated.

Comparison of electrical bills supplied by the utility prior to system installation and since startup did not indicate that the APU-100 system caused a noticeable increase in power consumption. Therefore, electrical costs associated with operation of the APU-100 system were assumed to be negligible.

Under normal operating conditions, routine labor activities to operate and maintain the system consumed only 15-20 minutes per day, as noted in Section 4.4.6. Therefore, the estimated labor cost is \$0.18/1,000 gallons of water treated.

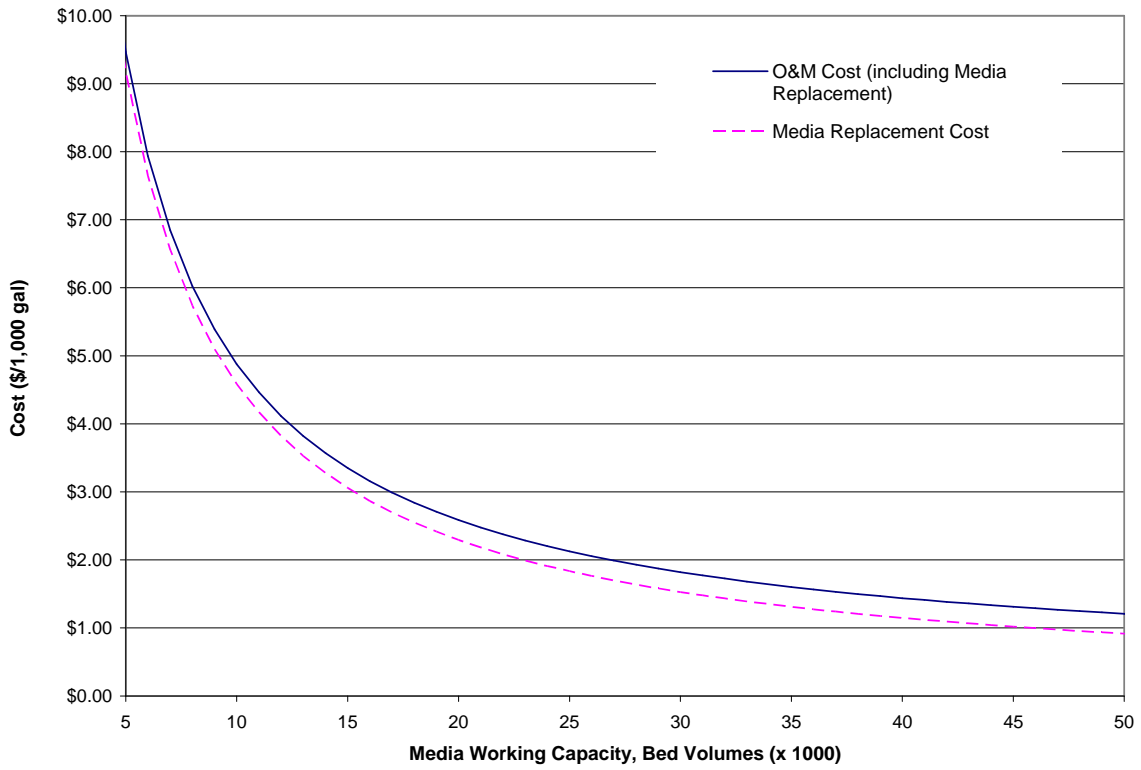

**Figure 4-14. Media Replacement and Operation and Maintenance Costs**

## 5.0 REFERENCES

- Battelle. 2003. *Revised Quality Assurance Project Plan for Evaluation of Arsenic Removal Technology*. Prepared under Contract No. 68-C-00-185, Task Order No. 0019, for U.S. EPA NRMRL. November 17.
- Battelle. 2004. *Final System Performance Evaluation Study Plan: U.S. EPA Demonstration of Arsenic Removal Technology at Rollinsford, New Hampshire*. Prepared under Contract No. 68-C-00-185, Task Order No. 0019 for U.S. EPA NRMRL. January 21.
- Chen, A.S.C., L. Wang, J. Oxenham, and W. Condit. 2004. *Capital Costs of Arsenic Removal Technologies: U.S. EPA Arsenic Removal Technology Demonstration Program Round 1*. EPA/600/R-04/201. U.S. EPA NRMRL, Cincinnati, OH.
- Edwards, M., S. Patel, L. McNeill, H. Chen, M. Frey, A.D. Eaton, R.C. Antweiler, and H.E. Taylor. 1998. "Considerations in As Analysis and Speciation." *J. AWWA* (March): 103-113.
- EPA, see United States Environmental Protection Agency.
- Knocke, W.R., et al. 1987. "Using Alternative Oxidants to Remove Dissolved Manganese from Waters Laden with Organics." *J. AWWA*(March), 79:3:75.
- Knocke, W.R., et al. 1990. *Alternative Oxidants for the Remove of Soluble Iron and Manganese*. Final report prepared for the AWWA Research Foundation, AWWARF, Denver, Colorado (March).
- United States Environmental Protection Agency. 2003. Minor Clarification of the National Primary Drinking Water Regulation for Arsenic. *Federal Register*, 40 CFR Part 141. March 25.
- United States Environmental Protection Agency. 2002. *Lead and Copper Monitoring and Reporting Guidance for Public Water Systems*. Prepared by EPA's Office of Water. EPA/816/R-02/009. February.
- United States Environmental Protection Agency. 2001. National Primary Drinking Water Regulations: Arsenic and Clarifications to Compliance and New Source Contaminants Monitoring. *Fed. Register.*, 66:14:6975. January 22.
- Wang, L., W. Condit, and A. Chen. 2004. *Technology Selection and System Design: U.S. EPA Arsenic Removal Technology Demonstration Program Round 1*. EPA/600/R-05/001. U.S. EPA NRMRL, Cincinnati, OH.

**APPENDIX A**

**OPERATIONAL DATA**

**EPA Arsenic Demonstration Project at Rollinsford, NH - Daily System Operation Log Sheet**

Week No.	Date	Pump House			Instrument Panel								
		Avg Operation Hours	Cumulative Operation Hours	Avg Flowrate	Flow Totalizer Vessel A	Flow Totalizer Vessel B	Cumulative Flow Totalizer	Cumulative Bed Volumes Treated	Head Loss		System Pressure		
									Tank A	Tank B	Influent	Effluent	ΔP
hr	hr	gpm	kgal	kgal	kgal	BV	psi	psi	psi	psi	psi		
1	02/09/04												
	02/10/04	0.0	0.0					8.2	7.4	79	64	15	
	02/11/04	16.5	16.5	104	27	29	56	151	9.1	7.5	80	64	16
	02/12/04	10.1	26.6	99	55	61	116	317	12.0	9.4	82	65	17
	02/13/04	9.9	36.5	101	80	92	172	470	13.0	9.8	82	64	18
	02/14/04	0.6	37.1	103	83	95	178	485	0.0	0.0	0	0	0
	02/15/04	0.1	37.2	-	83	96	179	487	12.5	11.2	84	64	20
2	02/16/04	10.1	47.3	106	112	126	238	649	10.5	9.0	80	64	16
	02/17/04	10.0	57.3	105	139	157	296	807	11.7	9.7	81	64	17
	02/18/04	10.0	67.3	102	167	187	354	964	12.5	10.2	81	64	17
	02/19/04	9.9	77.1	101	193	216	410	1,116	13.2	11.2	82	64	18
	02/20/04	9.9	87.1	101	220	246	466	1,269	14.4	12.2	83	64	19
	02/21/04	9.9	97.0	101	246	276	522	1,422	15+	14.4	84	64	20
	02/22/04	10.3	107.3	93	272	304	577	1,571	15+	15+	88	65	23
3	02/23/04	10.0	117.3		297	332	629	1,715	15+	15+	90	66	24
	02/24/04	10.5	127.8	98	325	362	687	1,873	13.5	11.8	85	68	17
	02/25/04	11.8	139.7	86	352	392	744	2,028	13.5	11.4	84	67	17
	02/26/04	8.3	148.0	114	378	420	797	2,172	15.0	13.0	85	67	18
	02/27/04	9.7	157.7	60	392	437	829	2,260	10.4	9.6	77	64	13
	02/28/04	11.9	169.5	89	428	461	889	2,423	13.4	14.6	86	67	19
	02/29/04	10.7	180.2	94	460	485	945	2,575	14.0	15+	88	68	20
4	03/01/04	7.2	187.4	86	481	499	980	2,670	7.8	8.5	76	65	11
	03/02/04	10.0	197.4	62	501	513	1014	2,762	11.8	11.8	80	66	14
	03/03/04	11.6	209.0	93	533	542	1075	2,930	9.6	9.5	82	66	16
	03/04/04	9.4	218.4	108	563	569	1132	3,083	12.0	11.2	82	66	16
	03/05/04	11.4	229.9	89	593	596	1188	3,238	13.0	12.6	83	66	17
	03/06/04	8.9	238.7	115	632	623	1255	3,420	15+	14.6	86	66	20
	03/07/04	10.0	248.7	60	639	640	1278	3,484	11.2	10.2	78	66	12
5	03/08/04	9.8	258.5	44	657	656	1313	3,577	9.6	9.6	77	65	12
	03/09/04	10.1	268.6	79	674	672	1347	3,670	10.0	9.8	79	67	12
	03/10/04	11.4	280.0	105	708	705	1414	3,852	11.5	10.2	82	67	15
	03/11/04	10.1	290.1	103	736	734	1470	4,005	12.6	11.4	83	66	17
	03/12/04	9.9	300.0	102	764	762	1526	4,158	14.2	13.0	84	66	18



**EPA Arsenic Demonstration Project at Rollinsford, NH - Daily System Operation Log Sheet (Continued)**

Week No.	Date	Pump House			Instrument Panel								
		Avg Operation Hours	Cumulative Operation Hours	Avg Flowrate	Flow Totalizer Vessel A	Flow Totalizer Vessel B	Cumulative Flow Totalizer	Cumulative Bed Volumes Treated	Head Loss		System Pressure		
									Tank A	Tank B	Influent	Effluent	ΔP
hr	hr	gpm	kgal	kgal	kgal	BV	psi	psi	psi	psi	psi		
11	04/19/04	10.0	567.2	85	1,460	1,462	2922	7,961	11.2	11.7	84	68	16
	04/20/04	10.8	578.0	88	1,486	1,488	2974	8,103	12.0	11.8	83	67	16
	04/21/04	9.9	587.9	89	1,510	1,508	3018	8,225	12.6	12.7	83	67	16
	04/22/04	10.0	597.9	89	1,534	1,538	3072	8,371	13.4	13.2	84	66	18
	04/23/04	11.1	609.0	89	1,562	1,566	3128	8,522	12.9	14.0	84	66	18
	04/24/04	10.1	619.2	89	1,586	1,592	3178	8,660	15+	15+	86	66	20
	04/25/04	11.3	630.4	90	1,615	1,619	3234	8,812	12.2	12.8	85	67	18
12	04/26/04	10.0	640.4	90	1,640	1,644	3284	8,949	13.6	14.6	84	67	17
	04/27/04	10.0	650.4	93	1,666	1,669	3334	9,085	14.8	15+	87	67	20
	04/28/04	10.0	660.4	85	1,690	1,694	3384	9,220	15.0	15+	87	66	21
	04/29/04	10.1	670.5	88	1,715	1,719	3434	9,356	15+	15+	86	65	21
	04/30/04	11.3	681.8	83	1,740	1,745	3486	9,497	15+	15+	87	64	23
	05/01/04	10.1	691.9	103	1,770	1,773	3543	9,654	12.6	13.2	82	65	17
	05/02/04	10.0	701.9	92	1,796	1,798	3594	9,793	12.2	13.2	81	65	16
13	05/03/04	9.9	711.8	90	1,821	1,823	3644	9,930	12.8	12.4	82	65	17
	05/04/04	10.0	721.8	90	1,846	1,848	3694	10,067	15.0	15+	85	64	21
	05/05/04	10.1	731.9	89	1,871	1,873	3745	10,203	15.0	15.0	85	66	19
	05/06/04	10.4	742.3	87	1,896	1,898	3794	10,338	15+	15+	85	66	19
	05/07/04	9.8	752.1	91	1,919	1,924	3843	10,472	15+	15+	86	66	20
	05/08/04	12.1	764.2	15	1,926	1,930	3855	10,505	10.5	18.0	80	66	14
	05/09/04	10.1	774.3	60	1,941	1,948	3889	10,596	11.5	20.0	76	64	12
14	05/10/04	9.7	783.9	62	1,957	1,966	3923	10,688	18.0	26.5	78	62	16
	05/11/04	10.3	794.3	58	1,973	1,983	3956	10,778	19.0	27.5	78	62	16
	05/12/04	10.1	804.3	59	1,988	2,000	3988	10,866	20.0	27.5	79	62	17
	05/13/04	24.9	829.3	56	2,023	2,043	4065	11,077	20.0	27.0	80	64	16
	05/14/04	23.6	852.8	54	2,055	2,083	4138	11,275	21.0	27.5	82	65	17
	05/15/04	25.5	878.3	53	2,089	2,124	4213	11,480	23.0	29.5	82	64	18
	05/16/04	6.2	884.5	70	2,101	2,135	4236	11,543	6.5	15.0	76	64	12
15	05/17/04	10.7	895.3	56	2,118	2,152	4270	11,634	10.0	14.0	72	64	8
	05/18/04	10.0	905.3	60	2,135	2,168	4303	11,725	10.0	16.0	75	64	11
	05/19/04	10.6	915.8	60	2,153	2,186	4339	11,823	11.5	18.5	75	64	11
	05/20/04	0.8	916.6	63	2,155	2,187	4342	11,831	13.0	21.5	76	63	13
	05/21/04	10.0	926.6	63	2,172	2,205	4376	11,924	13.5	21.0	74	62	12
	05/22/04	25.0	951.6	59	2,213	2,246	4459	12,150	13.0	21.0	76	62	14
	05/23/04	24.6	976.3	57	2,251	2,285	4536	12,360	13.0	21.0	77	64	13



**EPA Arsenic Demonstration Project at Rollinsford, NH - Daily System Operation Log Sheet (Continued)**

Week No.	Date	Pump House			Instrument Panel								
		Avg Operation Hours	Cumulative Operation Hours	Avg Flowrate	Flow Totalizer Vessel A	Flow Totalizer Vessel B	Cumulative Flow Totalizer	Cumulative Bed Volumes Treated	Head Loss		System Pressure		
									Tank A	Tank B	Influent	Effluent	ΔP
hr	hr	gpm	kgal	kgal	kgal	BV	psi	psi	psi	psi	psi		
16	05/24/04	10.0	986.3	58	2,268	2,302	4570	12,452	12.5	20.5	79	64	15
	05/25/04	20.4	1,006.7	60	2,284	2,319	4603	12,542	13.5	21.0	78	65	13
	05/26/04	NA	NA	NA	2,302	2,336	4638	12,636	15.0	25.0	78	62	16
	05/27/04	10.0	1,016.7	60	2,317	2,353	4671	12,726	14.0	20.5	76	64	12
	05/28/04	10.0	1,026.7	57	2,332	2,372	4703	12,816	25.0	30.0	82	63	19
	05/29/04	11.2	1,037.9	57	2,350	2,390	4740	12,915	14.0	23.0	84	63	21
	05/30/04	10.3	1,048.2	42	2,360	2,405	4765	12,984	25.0	30.0	100	64	36
17	05/31/04	0.0	1,048.2	0	NA	NA	NA	NA	NM	NM	NM	NM	NM
	06/01/04	NA	NA	NA	NA	NA	NA	NA	NM	NM	NM	NM	NM
	06/02/04	9.9	1,058.1	64	NA	NA	NA	NA	NM	NM	NM	NM	NM
	06/03/04	10.1	1,068.2	66	2,363	2,407	4770	12,996	20.0	30.0	100	64	36
	06/04/04	11.0	1,079.2	47	2,378	2,421	4799	13,078	25.0	30.0	96	64	32
	06/05/04	NA	NA	NA	NA	NA	NA	NA	NM	NM	NM	NM	NM
	06/06/04	NA	NA	NA	NA	NA	NA	NA	NM	NM	NM	NM	NM
18	06/07/04	32.5	1,111.7	59	2,431	2,474	4905	13,365	25.0	30+	96	64	32
	06/08/04	9.9	1,121.6	56	2,447	2,490	4937	13,452	11.0	20.0	75	62	13
	06/09/04	11.1	1,132.7	57	2,462	2,510	4972	13,548	25.0	30+	87	63	24
	06/10/04	23.8	1,156.5	54	2,497	2,550	5046	13,750	25.0	30+	88	62	26
	06/11/04	24.0	1,180.5	56	2,524	2,599	5123	13,959	25.0	30+	80	60	20
	06/12/04	18.4	1,198.9	54	2,545	2,637	5182	14,121	25.0	30+	92	62	30
	06/13/04	10.2	1,209.1	54	2,554	2,657	5211	14,200	25.0	30+	96	62	34
19	06/14/04	10.3	1,219.4	50	2,567	2,685	5252	14,310	28.0	30+	100+	64	36+
	06/15/04	21.6	1,241.0	62									
	06/16/04												
	06/17/04								<b>System Not Operating</b>				
	06/18/04												
	06/19/04	NM	1,316.3		2,586	2,699	5285	14,402	17.0	17.0	80	63	17
	06/20/04	10.1	1,326.4	54	2,599	2,718	5316	14,486	26.0	26.0	86	62	24
20	06/21/04	10.0	1,336.4	55	2,620	2,737	5357	14,598	29.0	29.0	90	61	29
	06/22/04	10.0	1,346.4	33	2,623	2,755	5378	14,655	30+	30+	93	60	33
	06/23/04	10.1	1,356.5	68	2,635	2,769	5404	14,725	30+	30+	93	60	33
	06/24/04												
	06/25/04												
	06/26/04												
	06/27/04												

A-4

**EPA Arsenic Demonstration Project at Rollinsford, NH - Daily System Operation Log Sheet (Continued)**

Week No.	Date	Pump House			Instrument Panel									
		Avg Operation Hours hr	Cumulative Operation Hours hr	Avg Flowrate gpm	Flow Totalizer Vessel A kgal	Flow Totalizer Vessel B kgal	Cumulative Flow Totalizer kgal	Cumulative Bed Volumes Treated BV	Head Loss		System Pressure			
									Tank A psi	Tank B psi	Influent psi	Effluent psi	ΔP psi	
21	06/28/04													
	06/29/04													
	06/30/04													
	07/01/04													
	07/02/04													
	07/03/04													
	07/04/04													
22	07/05/04													
	07/06/04													
	07/07/04													
	07/08/04													
	07/09/04	96.4	1,452.8	123	2,657	2,793	5450	14,851	10.0	7.5	72	63	9	
	07/10/04	10.1	1,462.9	63	2,673	2,814	5487	14,951	10.0	7.5	71	63	8	
	07/11/04	10.1	1,473.0	63	2,693	2,834	5526	15,058	11.0	9.0	74	63	11	
23	07/12/04	10.2	1,483.2	60	2,706	2,854	5560	15,149	11.5	8.0	73	62	11	
	07/13/04	10.1	1,493.3	63	2,722	2,874	5596	15,248	13.0	10.0	74	62	12	
	07/14/04	10.4	1,503.7	62	2,739	2,894	5633	15,349	15.0	12.0	75	62	13	
	07/15/04	10.0	1,513.7	60	2,754	2,914	5668	15,444	17.5	14.0	78	62	16	
	07/16/04	9.9	1,523.6	62	2,770	2,934	5703	15,541	18.0	14.5	79	63	16	
	07/17/04	10.0	1,533.6	65	2,786	2,954	5740	15,640	11.0	9.0	72	64	8	
	07/18/04	10.3	1,543.9	60	2,802	2,974	5775	15,737	15.0	13.0	78	63	15	
24	07/19/04	10.1	1,554.0	61	2,817	2,993	5811	15,833	20.0	15.0	82	62	20	
	07/20/04	10.1	1,564.1	61	2,835	3,010	5846	15,928	21.0	16.0	82	62	20	
	07/21/04	10.3	1,574.4	60	2,853	3,028	5881	16,024	25.0	17.0	85	62	23	
	07/22/04	12.3	1,586.7	91	2,883	3,055	5939	16,181	30+	30+	100+	64	36+	
	07/23/04	10.3	1,597.0	108	2,916	3,086	6003	16,356	30+	30+	100+	64	36+	
	07/24/04	10.8	1,607.8	108	2,940	3,109	6049	16,482	30+	30+	98	64	34	
	07/25/04	10.2	1,618.0	105	2,963	3,137	6100	16,622	30+	30+	100	66	34	
25	07/26/04	10.1	1,628.1	104	2,991	3,156	6148	16,751	30+	30+	100	66	34	
	07/27/04	10.9	1,639.0	110	3,015	3,190	6204	16,906	19.0	18.0	84	66	18	
	07/28/04	10.7	1,649.7	103	3,036	3,221	6256	17,047	22.0	21.5	88	66	22	
	07/29/04	16.0	1,665.7	107	3,066	3,268	6334	17,260	30+	30+	100	65	35	
	07/30/04	10.8	1,676.5	110	3,094	3,298	6392	17,417	20.0	19.0	84	64	20	
	07/31/04	10.0	1,686.6	109	3,116	3,329	6445	17,561	20.0	19.0	82	63	19	
	08/01/04	14.8	1,701.3	106	3,147	3,372	6519	17,762	22.0	22.0	87	64	23	

A-5

**System Not Operating**

**EPA Arsenic Demonstration Project at Rollinsford, NH - Daily System Operation Log Sheet (Continued)**

Week No.	Date	Pump House			Instrument Panel								
		Avg Operation Hours hr	Cumulative Operation Hours hr	Avg Flowrate gpm	Flow Totalizer Vessel A kgal	Flow Totalizer Vessel B kgal	Cumulative Flow Totalizer kgal	Cumulative Bed Volumes Treated BV	Head Loss		System Pressure		
									Tank A psi	Tank B psi	Influent psi	Effluent psi	$\Delta P$ psi
26	08/02/04	0.0	1,701.3		3,167	3,402	6569	17,899	23.5	23.0	90	64	26
	08/03/04	20.2	1,721.5	51	3,188	3,431	6619	18,035	25.0	24.0	92	64	28
	08/04/04	10.0	1,731.5	112	3,207	3,461	6668	18,169	25.0	25.0	90	64	26
	08/05/04	12.0	1,743.5	111	3,242	3,497	6739	18,362	13.0	12.0	76	64	12
	08/06/04	9.9	1,753.4	111	3,270	3,527	6797	18,520	14.0	12.0	74	64	10
	08/07/04	10.1	1,763.5	111	3,300	3,558	6857	18,685	16.0	15.0	78	64	14
	08/08/04	10.2	1,773.7	110	3,329	3,588	6917	18,847	16.0	16.5	80	65	15
27	08/09/04	9.7	1,783.4	113	3,356	3,619	6975	19,006	17.0	16.0	82	65	17
	08/10/04	0.0	1,783.4		3,356	3,619	6975	19,006	17.0	17.0	80	64	16
	08/11/04	11.6	1,795.0	108	3,387	3,654	7041	19,185	16.5	16.0	80	64	16
	08/12/04	NM	NM	NM	NM	NM	NM	NM	NM	NM	NM	NM	NM
	08/13/04	19.7	1,814.7	114	3,439	3,718	7158	19,503	19.0	18.0	82	64	18
	08/14/04	10.1	1,824.8	114	3,465	3,752	7217	19,664	21.0	20.0	84	64	20
	08/15/04	10.3	1,835.0	109	3,489	3,785	7274	19,821	21.0	20.0	86	65	21

**APPENDIX B**  
**ANALYTICAL DATA**

### Analytical Results from Long-Term Sampling at Rollinsford, NH

Sampling Date		02/10/04 <sup>(c)</sup>			02/17/04 <sup>(d)</sup>				02/24/04				03/02/04			
Sampling Location	Parameter	IN	AP	TT	IN	AP	TA	TB	IN	AP	TA	TB	IN	AP	TA	TB
Unit	Unit															
Bed Volume		-	-	0	-	-	759	855	-	-	1,773	1,972	-	-	2,728	2,796
Alkalinity	mg/L <sup>(a)</sup>	165	165	161	149	174	170	170	176	176	185	189	164	180	164	164
Fluoride	mg/L	0.6	0.6	0.6	-	-	-	-	-	-	-	-	-	-	-	-
Sulfate	mg/L	40	40	45	-	-	-	-	-	-	-	-	-	-	-	-
Orthophosphate	mg/L <sup>(b)</sup>	<0.10	<0.10	<0.10	<0.10	<0.10	<0.10	<0.10	<0.10	<0.10	<0.10	<0.10	<0.10	<0.10	<0.10	<0.10
Silica (as SiO <sub>2</sub> )	mg/L	13.9	13.7	6.6	15.0	15.2	15.2	15.1	15.5	15.4	14.4	14.6	14.1	13.9	14.9	14.0
NO <sub>3</sub> -N	mg/L	<0.08	<0.08	<0.08	-	-	-	-	-	-	-	-	-	-	-	-
Turbidity	NTU	0.8	0.8	0.3	0.6	0.6	0.6	0.5	0.5	0.5	0.5	0.3	1.8	0.3	1.0	0.7
pH	-	8.3	7.3	7.5	7.0	6.8	7.0	7.1	7.0	7.4	7.3	7.4	8.0	7.6	7.4	7.5
Temperature	°C	10.6	11.3	11.1	10.0	10.2	10.6	11.5	9.8	11.6	11.8	11.8	12.8	13.0	13.1	13.3
DO	mg/L	2.2	1.0	2.0	4.7	3.1	2.8	2.8	4.5	3.6	3.6	4.2	4.4	3.2	3.2	3.8
ORP	mV	-86	-28	-25	0	7	-2	-4	4	24	18	18	-60	-33	-23	-27
Free Chlorine	mg/L	-	-	-	-	-	-	-	-	-	-	-	-	-	-	-
Total Chlorine	mV	-	-	-	-	-	-	-	-	-	-	-	-	-	-	-
Total Hardness	mg/L <sup>(a)</sup>	73.0	78.4	93.5	-	-	-	-	-	-	-	-	-	-	-	-
Ca Hardness	mg/L <sup>(a)</sup>	40.5	42.4	51.8	-	-	-	-	-	-	-	-	-	-	-	-
Mg Hardness	mg/L <sup>(a)</sup>	32.5	36.0	41.7	-	-	-	-	-	-	-	-	-	-	-	-
As (total)	µg/L	39.5	40.8	0.5	35.5	37.0	3.1	2.2	45.8	47.7	3.3	3.1	46.6	46.5	6.4	7.7
As (total soluble)	µg/L	34.9	35.7	0.4	-	-	-	-	-	-	-	-	-	-	-	-
As (particulate)	µg/L	4.6	5.1	0.1	-	-	-	-	-	-	-	-	-	-	-	-
As (III)	µg/L	22.6	23.3	0.5	-	-	-	-	-	-	-	-	-	-	-	-
As (V)	µg/L	12.3	12.4	<0.1	-	-	-	-	-	-	-	-	-	-	-	-
Total Fe	µg/L	170	166	45	236	148	105	51	100	120	<25	<25	166	276	31	106
Dissolved Fe	µg/L	74	81	<25	-	-	-	-	-	-	-	-	-	-	-	-
Total Mn	µg/L	147	149	5.8	169	119	83.9	92.3	120	118	68.9	69.5	133	155	61.5	88.3
Dissolved Mn	µg/L	147	149	5.7	-	-	-	-	-	-	-	-	-	-	-	-

(a) Measured as CaCO<sub>3</sub>. (b) Measured as PO<sub>4</sub>. (c) Water quality parameters and metals sampled on January 30, 2004. (d) On-site water quality measurements performed on February 16, 2004.  
 IN = inlet; AP = after pH adjustment; TA = after tank A; TB = after the tank B; TT = after tanks combined.  
 NA = data not available.

### Analytical Results from Long-Term Sampling at Rollinsford, NH

Sampling Date		03/09/04 <sup>(c)</sup>			03/30/04 <sup>(d)</sup>				04/06/04				04/14/04 <sup>(e)</sup>			
Sampling Location	Parameter	IN	AP	TT	IN	AP	TA	TB	IN	AP	TA	TB	IN	AP	TA	TB
Bed Volume		-	-	3,670	-	-	5,043	5,045	-	-	6,012	6,025	-	-	6,994	7,011
Alkalinity	mg/L <sup>(a)</sup>	164	156	160	175	167	165	163	176	180	180	176	182	176	172	174
Fluoride	mg/L	0.6	0.6	0.6	-	-	-	-	-	-	-	-	-	-	-	-
Sulfate	mg/L	37	35	38	-	-	-	-	-	-	-	-	-	-	-	-
Orthophosphate	mg/L <sup>(b)</sup>	<0.10	<0.10	<0.10	<0.10	<0.10	<0.10	<0.10	<0.10	<0.10	<0.10	<0.10	<0.10	<0.10	<0.10	<0.10
Silica (as SiO <sub>2</sub> )	mg/L	13.3	13.4	13.2	14.1	14.1	13.8	13.5	16.0	16.5	15.1	15.7	15.2	14.8	15.4	15.0
NO <sub>3</sub> -N	mg/L	<0.04	<0.04	<0.04	-	-	-	-	-	-	-	-	-	-	-	-
Turbidity	NTU	1.0	1.6	0.4	1.0	2.0	0.8	0.5	0.9	1.1	1.1	0.7	0.4	2.1	0.3	0.7
pH	-	8.0	7.5	7.5	NA	NA	NA	NA	8.1	7.5	7.5	7.5	7.8	7.3	7.4	7.4
Temperature	°C	10.4	10.5	10.3	NA	NA	NA	NA	12.5	12.4	12.4	12.4	10.1	8.9	9.0	9.1
DO	mg/L	4.7	3.5	2.0	NA	NA	NA	NA	4.2	3.2	2.9	3.4	4.5	3.9	2.8	2.8
ORP	mV	-59	-29	-27	NA	NA	NA	NA	-64	-31	-32	-33	-51	-27	-30	-31
Free Chlorine	mg/L	-	-	-	-	-	-	-	-	-	-	-	-	-	-	-
Total Chlorine	mV	-	-	-	-	-	-	-	-	-	-	-	-	-	-	-
Total Hardness	mg/L <sup>(a)</sup>	80.1	83.3	82.4	-	-	-	-	-	-	-	-	-	-	-	-
Ca Hardness	mg/L <sup>(a)</sup>	51.4	52.8	53.4	-	-	-	-	-	-	-	-	-	-	-	-
Mg Hardness	mg/L <sup>(a)</sup>	28.7	30.5	29.0	-	-	-	-	-	-	-	-	-	-	-	-
As (total)	µg/L	38.5	42.1	5.5	35.9	37.8	2.1	1.7	46.3	50.5	4.5	3.3	45.2	50.1	4.9	5.0
As (total soluble)	µg/L	36.7	36.4	4.1	-	-	-	-	-	-	-	-	-	-	-	-
As (particulate)	µg/L	1.8	5.7	1.4	-	-	-	-	-	-	-	-	-	-	-	-
As (III)	µg/L	20.7	NA	4.1	-	-	-	-	-	-	-	-	-	-	-	-
As (V)	µg/L	16.0	NA	<0.1	-	-	-	-	-	-	-	-	-	-	-	-
Total Fe	µg/L	127	485	<25	130	359	<25	<25	97	133	<25	<25	75	276	<25	<25
Dissolved Fe	µg/L	22	51	<25	-	-	-	-	-	-	-	-	-	-	-	-
Total Mn	µg/L	137	138	142	78.1	104	14.2	15.2	96.5	96.3	6.9	3.5	110	111	3.0	1.8
Dissolved Mn	µg/L	99.1	132	99.2	-	-	-	-	-	-	-	-	-	-	-	-

(a) Measured as CaCO<sub>3</sub>. (b) Measured as PO<sub>4</sub>. (c) On-site water quality parameters measured on March 10, 2004. (d) Prechlorination started on March 30, 2004.

(e) On-site water quality parameters measured on April 13, 2004.

IN = inlet; AP = after pH adjustment and after prechlorination; TA = after tank A; TB = after the tank B; TT = after tanks combined.

NA = data not available.

### Analytical Results from Long-Term Sampling at Rollinsford, NH

Sampling Date		04/19/04			04/29/04				05/05/04				05/18/04			
Sampling Location	Parameter	IN	AP	TT	IN	AP	TA	TB	IN	AP	TA	TB	IN	AP	TA	TB
Bed Volume	10 <sup>3</sup>	–	–	8.0	–	–	9.3	9.4	–	–	10.2	10.2	–	–	11.6	11.8
Alkalinity	mg/L <sup>(a)</sup>	188	188	196	195	191	187	171	259	231	219	207	176 197	181 185	189 185	193 185
Fluoride	mg/L	0.6	0.6	0.6	–	–	–	–	–	–	–	–	–	–	–	–
Sulfate	mg/L	46	46	40	–	–	–	–	–	–	–	–	–	–	–	–
Orthophosphate	mg/L <sup>(b)</sup>	<0.10	<0.10	<0.10	NA	NA	NA	NA	0.11	<0.10	<0.10	<0.10	<0.10 0.12	0.12 <0.10	<0.10 <0.10	<0.10 <0.10
Silica (as SiO <sub>2</sub> )	mg/L	15.3	15.6	15.3	14.0	14.2	15.1	15.2	15.6	15.4	15.3	15.7	14.2 14.7	14.4 14.7	14.8 14.7	14.7 14.7
NO <sub>3</sub> -N	mg/L	<0.05	<0.05	<0.05	–	–	–	–	–	–	–	–	–	–	–	–
Turbidity	NTU	0.4	0.3	0.6	1.0	1.4	0.7	0.7	1.3	0.9	0.4	0.5	0.7 2.4	0.7 0.9	0.5 0.6	0.5 0.4
pH	–	7.9	7.2	7.5	7.8	7.1	7.2	7.2	8.0	7.6	7.5	7.5	8.2	7.5	7.4	7.4
Temperature	°C	12.4	12.5	13.5	13.6	12.8	12.6	12.5	14.8	14.2	14.3	13.9	14.8	14.1	14.0	13.9
DO	mg/L	5.4	3.3	2.0	4.3	2.0	1.9	2.3	4.3	3.6	3.4	4.1	3.9	4.1	3.9	4.0
ORP	mV	-64	-16	-33	-50	-7	-10	-11	-56	-30	-27	-26	-66	-24	-18	-19
Free Chlorine	mg/L	–	–	–	–	0.40	–	–	–	0.06	–	–	–	0.14	–	–
Total Chlorine	mV	–	–	–	–	0.60	–	–	–	0.30	–	–	–	0.30	–	–
Total Hardness	mg/L <sup>(a)</sup>	54.9	54.3	64.6	–	–	–	–	–	–	–	–	–	–	–	–
Ca Hardness	mg/L <sup>(a)</sup>	30.2	29.7	35.4	–	–	–	–	–	–	–	–	–	–	–	–
Mg Hardness	mg/L <sup>(a)</sup>	24.7	24.6	29.2	–	–	–	–	–	–	–	–	–	–	–	–
As (total)	µg/L	41.3	42.5	6.1	36.3	37.4	3.5	3.3	39.9	42.9	5.6	5.5	38.3 37.0	41.7/38.1 <sup>(c)</sup> 40.1/35.6 <sup>(c)</sup>	6.9 6.5	6.2 5.9
As (total soluble)	µg/L	35.5	35.4	5.1	–	–	–	–	–	–	–	–	–	–	–	–
As (particulate)	µg/L	5.8	7.1	1.0	–	–	–	–	–	–	–	–	–	–	–	–
As (III)	µg/L	18.1	0.5	0.5	–	–	–	–	–	–	–	–	–	–	–	–
As (V)	µg/L	17.4	34.9	4.6	–	–	–	–	–	–	–	–	–	–	–	–
Total Fe	µg/L	68	53	<25	115	214	<25	<25	211	144	<25	<25	83 89	350/426 <sup>(c)</sup> 46/44 <sup>(c)</sup>	<25 <25	<25 <25
Dissolved Fe	µg/L	29	<25	<25	–	–	–	–	–	–	–	–	–	–	–	–
Total Mn	µg/L	112	109	1.5	85.1	93.4	3.3	2.7	102	114	4.1	2.2	58.9 58.1	66.3/66.5 <sup>(c)</sup> 59.5/59.8 <sup>(c)</sup>	4.5 0.6	1.2 1.1
Dissolved Mn	µg/L	112	105	1.0	–	–	–	–	–	–	–	–	–	–	–	–

(a) Measured as CaCO<sub>3</sub>. (b) Measured as PO<sub>4</sub>. (c) (/) indicates re-run data with original result/re-run result.

IN = inlet; AP = after pH adjustment and after prechlorination; TA = after tank A; TB = after the tank B; TT = after tanks combined.

NA = data not available.

### Analytical Results from Long-Term Sampling at Rollinsford, NH

Sampling Date		05/25/04			06/08/04 <sup>(d)</sup>				06/22/04				07/13/04 <sup>(e)</sup>	
Sampling Location	Parameter	IN	AP	TT	IN	AP	TA	TB	IN	AP	TA	TB	IN	TT
Unit	Unit													
Bed Volume	10 <sup>3</sup>	–	–	12.5	–	–	13.3	13.6	–	–	14.3	15.0	–	15.2
Alkalinity	mg/L <sup>(a)</sup>	182	186	190	240	236	203	199	179	162	162	171	184	176
Fluoride	mg/L	0.6	0.6	0.6	–	–	–	–	–	–	–	–	0.5	0.5
Sulfate	mg/L	37	40	40	–	–	–	–	–	–	–	–	72	80
Orthophosphate	mg/L <sup>(b)</sup>	<0.10	<0.10	<0.10	<0.10	<0.10	<0.10	<0.10	<0.10	<0.10	<0.10	<0.10	<0.10	<0.10
Silica (as SiO <sub>2</sub> )	mg/L	15.0	14.9	13.9	15.0	14.8	15.1	15.0	16.1	15.2	14.9	15.6	14.7	14.5
NO <sub>3</sub> -N	mg/L	<0.04	<0.04	<0.04	–	–	–	–	–	–	–	–	<0.04	<0.04
Turbidity	NTU	3.3	1.0	1.3	0.5	1.3	3.1	0.7	2.6	14	0.7	1.6	0.5	0.2
pH	–	8.0	7.5	8.0	7.9	7.0	7.1	7.1	NA	NA	NA	NA	7.5	7.0
Temperature	°C	10.9	11.0	10.7	17.2	16.0	15.9	16.0	NA	NA	NA	NA	14.1	12.1
DO	mg/L	4.6	4.1	2.2	4.4	2.8	2.6	3.1	NA	NA	NA	NA	3.4	3.0
ORP	mV	-58	-25	-50	-48	1	-2	-3	NA	NA	NA	NA	-30	-3
Free Chlorine	mg/L	–	1.75	3.20	–	0.28	–	–	–	NA	–	–	–	0.05
Total Chlorine	mV	–	2.52	3.24	–	0.58	–	–	–	NA	–	–	–	0.23
Total Hardness	mg/L <sup>(a)</sup>	54.1	53.9	54.7	–	–	–	–	–	–	–	–	101.0	103.1
Ca Hardness	mg/L <sup>(a)</sup>	31.9	32.1	32.6	–	–	–	–	–	–	–	–	52.8	53.4
Mg Hardness	mg/L <sup>(a)</sup>	22.2	21.8	22.1	–	–	–	–	–	–	–	–	48.2	49.7
As (total)	µg/L	41.9	40.0	20.3/ 17.8 <sup>(c)</sup>	38.5	75.2/ 67.6 <sup>(c)</sup>	3.9	4.5	39.1	45.6	10.6/ 19.4 <sup>(c)</sup>	5.0	32.7	2.4
As (total soluble)	µg/L	35.7	35.5	19.1	–	–	–	–	–	–	–	–	29.8	2.1
As (particulate)	µg/L	6.2	4.5	1.2	–	–	–	–	–	–	–	–	2.9	0.3
As (III)	µg/L	16.9	0.8	0.8	–	–	–	–	–	–	–	–	25.8	0.6
As (V)	µg/L	18.8	34.7	18.3	–	–	–	–	–	–	–	–	4.0	1.5
Total Fe	µg/L	489/ 484 <sup>(c)</sup>	36	<25/ <25 <sup>(c)</sup>	37	898/ 911 <sup>(c)</sup>	<25	<25	175	624	<25	29	307	<25
Dissolved Fe	µg/L	<25	<25	<25	–	–	–	–	–	–	–	–	183	<25
Total Mn	µg/L	95.1/ 92.9 <sup>(c)</sup>	79.1	0.6/ 0.6 <sup>(c)</sup>	104	136/ 134 <sup>(c)</sup>	1.0	1.1	79.1	107	8.5	2.3	245	1.0
Dissolved Mn	µg/L	83.7	69.6	0.6	–	–	–	–	–	–	–	–	235	0.9

(a) Measured as CaCO<sub>3</sub>.

(b) Measured as PO<sub>4</sub>.

(c) ( / ) indicates re-run data with original result/re-run result.

(d) On-site water quality parameters measured on June 9, 2004.

(e) AP sample tap removed during system maintenance on July 1-2 and later re-installed.

IN = inlet; AP = after pH adjustment and after prechlorination; TA = after tank A; TB = after the tank B; TT = after tanks combined.

NA = data not available.



### Analytical Results from Long-Term Sampling at Rollinsford, NH

Sampling Date		07/20/04				07/29/04				08/04/04				08/10/04		
Sampling Location	Parameter	IN	AP	TA	TB	IN	AP	TA	TB	IN	AP	TA	TB	IN	AP	TT
Bed Volume	10 <sup>3</sup>	-	-	15.5	16.4	-	-	16.4	17.4	-	-	17.4	18.7	-	-	19.0
Alkalinity	mg/L <sup>(a)</sup>	164	164	160	172	177	177	177	181	192	188	184	180	176	168	160
Fluoride	mg/L	-	-	-	-	-	-	-	-	-	-	-	-	0.6	0.6	0.5
Sulfate	mg/L	-	-	-	-	-	-	-	-	-	-	-	-	35	33	33
Orthophosphate	mg/L <sup>(b)</sup>	<0.10	<0.10	<0.10	<0.10	<0.10	<0.10	<0.10	<0.10	<0.10	<0.10	<0.10	<0.10	<0.10	<0.10	<0.10
Silica (as SiO <sub>2</sub> )	mg/L	13.9	13.9	14.3	14.2	15.2	14.9	14.7	15.0	14.7	15.3	15.0	14.7	13.6	13.7	14.4
NO <sub>3</sub> -N	mg/L	-	-	-	-	-	-	-	-	-	-	-	-	<0.04	<0.04	<0.04
Turbidity	NTU	0.8	0.6	0.7	0.7	36 <sup>(d)</sup>	2.3	7.4	2.1	0.7	0.3	0.3	13	29	0.8	0.4
pH	-	7.5	7.2	7.2	7.1	NA	NA	NA	NA	8.0	7.6	7.7	7.6	7.9	7.4	7.5
Temperature	°C	14.1	13.6	13.6	14.1	NA	NA	NA	NA	19.5	17.7	16.4	17.5	15.1	15.3	15.0
DO	mg/L	3.4	2.7	3.8	2.2	NA	NA	NA	NA	3.2	2.8	2.6	3.2	3.2	2.4	2.0
ORP	mV	-30	-17	-13	-11	NA	NA	NA	NA	-61	-44	-41	-43	-60	-27	-34
Free Chlorine	mg/L	-	0.07	-	-	-	NA	-	-	-	0.21	-	-	-	0.05	0.04
Total Chlorine	mV	-	0.71	-	-	-	NA	-	-	-	0.44	-	-	-	0.20	0.26
Total Hardness	mg/L <sup>(a)</sup>	-	-	-	-	-	-	-	-	-	-	-	-	62.7	68.1	79.6
Ca Hardness	mg/L <sup>(a)</sup>	-	-	-	-	-	-	-	-	-	-	-	-	34.2	38.2	41.6
Mg Hardness	mg/L <sup>(a)</sup>	-	-	-	-	-	-	-	-	-	-	-	-	28.5	29.9	38.0
As (total)	µg/L	28.7	30.0	2.3	2.9	36.1	42.7	8.8/ 7.9 <sup>(c)</sup>	12.5/ 11.9 <sup>(c)</sup>	42.7	42.4	17.2/ 17.2 <sup>(c)</sup>	21.9/ 16.6 <sup>(c)</sup>	31.9	30.4	5.1
As (total soluble)	µg/L	-	-	-	-	-	-	-	-	-	-	-	-	31.6	30.7	5.1
As (particulate)	µg/L	-	-	-	-	-	-	-	-	-	-	-	-	0.3	<0.1	<0.1
As (III)	µg/L	-	-	-	-	-	-	-	-	-	-	-	-	12.4	0.5	0.4
As (V)	µg/L	-	-	-	-	-	-	-	-	-	-	-	-	19.2	30.2	4.7
Total Fe	µg/L	178	171	<25	<25	260	373	32/ 37.5 <sup>(c)</sup>	<25/ <25 <sup>(c)</sup>	99	146	131/ 125 <sup>(c)</sup>	280/ 186 <sup>(c)</sup>	89	<25	<25
Dissolved Fe	µg/L	-	-	-	-	-	-	-	-	-	-	-	-	<25	<25	<25
Total Mn	µg/L	196	196	4.3	5.2	226	241	11.8/ 12.3 <sup>(c)</sup>	8.0/ 7.4 <sup>(c)</sup>	127	163	24.2/ 27.7 <sup>(c)</sup>	65.3/ 69.6 <sup>(c)</sup>	51.9	60.0	1.6
Dissolved Mn	µg/L	-	-	-	-	-	-	-	-	-	-	-	-	48.9	50.2	1.9

(a) Measured as CaCO<sub>3</sub>. (b) Measured as PO<sub>4</sub>. (c) (/) indicates re-run data with original result/re-run result.

IN = inlet; AP = after pH adjustment and after prechlorination; TA = after tank A; TB = after the tank B; TT = after tanks combined

NA = data not available.