



Improved ATV Trail Cattle Guard

Deb Mucci, *Mechanical Engineering Technician*; Brian Vachowski, *Program Leader*

The Southwest Montana ATV (all-terrain vehicle) Trail Cattle Guard (MTDC-1049) has been developed to replace an earlier design, the Deerlodge Trail Cattle Guard (MTDC-951-2).

The Deerlodge Trail Cattle Guard proved to be too short (only 34 inches on each side of a wire fence) to prevent livestock from trying to jump over it. Also, cattle got their legs caught in the 4-inch gap between the rails and could not free themselves. The Deerlodge Trail Cattle Guard was featured as one of four OHV (off-highway vehicle) trail cattle guard designs in MTDC's 1998 report, *Cattle Guards for Off-Highway Vehicle Trails* (9823-2826-MTDC), available at: <http://www.fs.fed.us/eng/pubs/htmlpubs/htm98232826/>

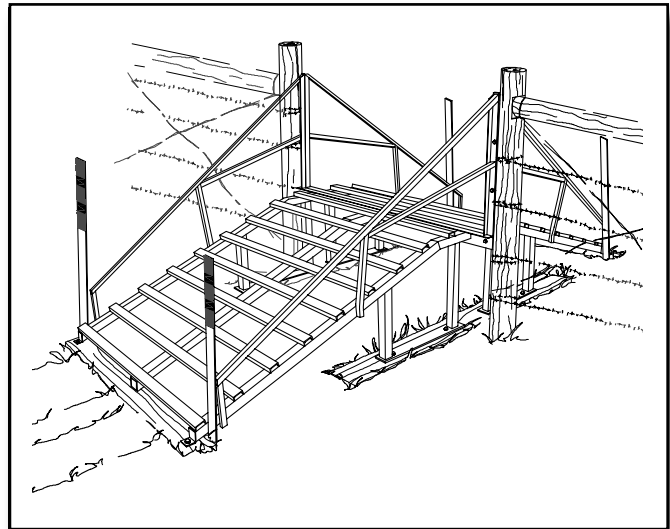

Figure 1—The Southwest Montana ATV Trail Cattle Guard is being used on national forests and BLM public lands in Montana. Object markers may be placed on the center posts instead of on fiberglass stakes at the corners.

Features of the New Cattle Guard

Eric Tolf from the Beaverhead-Deerlodge National Forest and Tim Hippert from McGrew Machine and Fabricating, Inc., designed the Southwest Montana ATV Trail Cattle Guard, borrowing some ideas from other designs (figure 1). The deck is fabricated from 2- by 1-inch steel channel, with a 6-inch gap between the pieces of channel. The two halves of the deck join at the middle. The halves can be bolted to each other, or to wooden fenceposts. Attaching the halves directly to the posts will not reduce the effective width (54 inches) of the cattle guard.

The deck is about 22 inches above the ground and the top of the sides are about 51 inches above the ground. The sides flare out from the bottom to the top, providing a visual cue to keep cattle from trying to jump the cattle guard, and serving as a physical barrier to stop ATVs from sliding off the cattle guard. The cattle guard is painted with flat brown oil-based paint.

Installation

Usually, these cattle guards are installed along an existing fence. Choose crossing locations where cattle are not accustomed to bunching up, because cattle that are pushed or bunched up may be forced to step onto the cattle guard or may be tempted to jump it. Sites need to be fairly level. Preservative-treated timbers or thick planks usually are placed beneath the structure, with the soil excavated so that the buried timbers are nearly flush with the ground surface. Timbers support the cattle guard and help keep it in place. Lag screws fasten the cattle guard to the timbers.

Typically, treated wood fenceposts are part of a brace panel that supports the fence on both sides of the cattle guard. Although the two halves of the deck can be screwed directly to these posts, normally they are bolted to each other instead of to the posts.



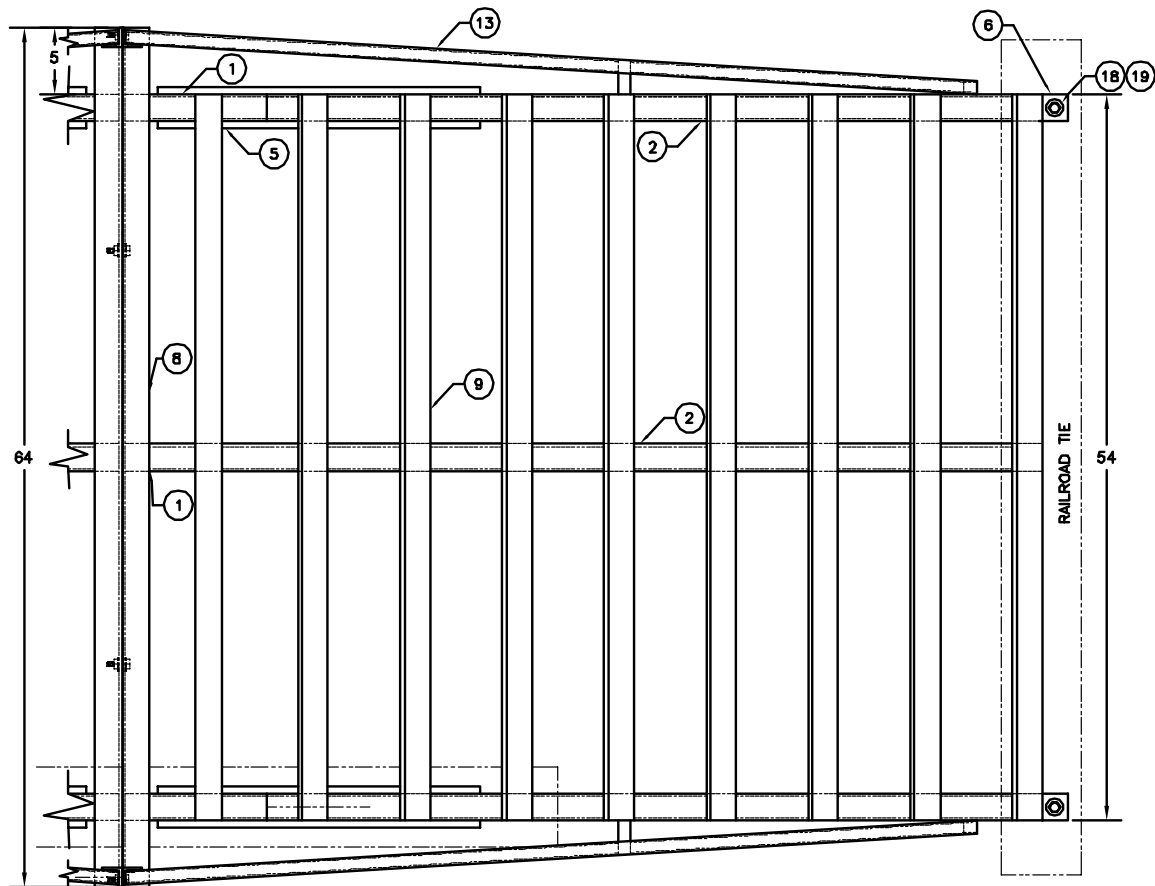

1 FRAME (T)
SCALE X2

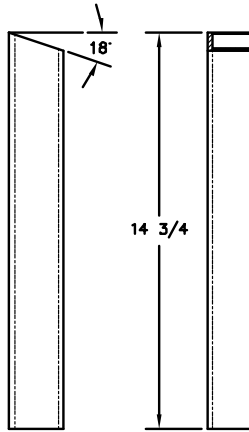

4 BACK LEG
SCALE X2

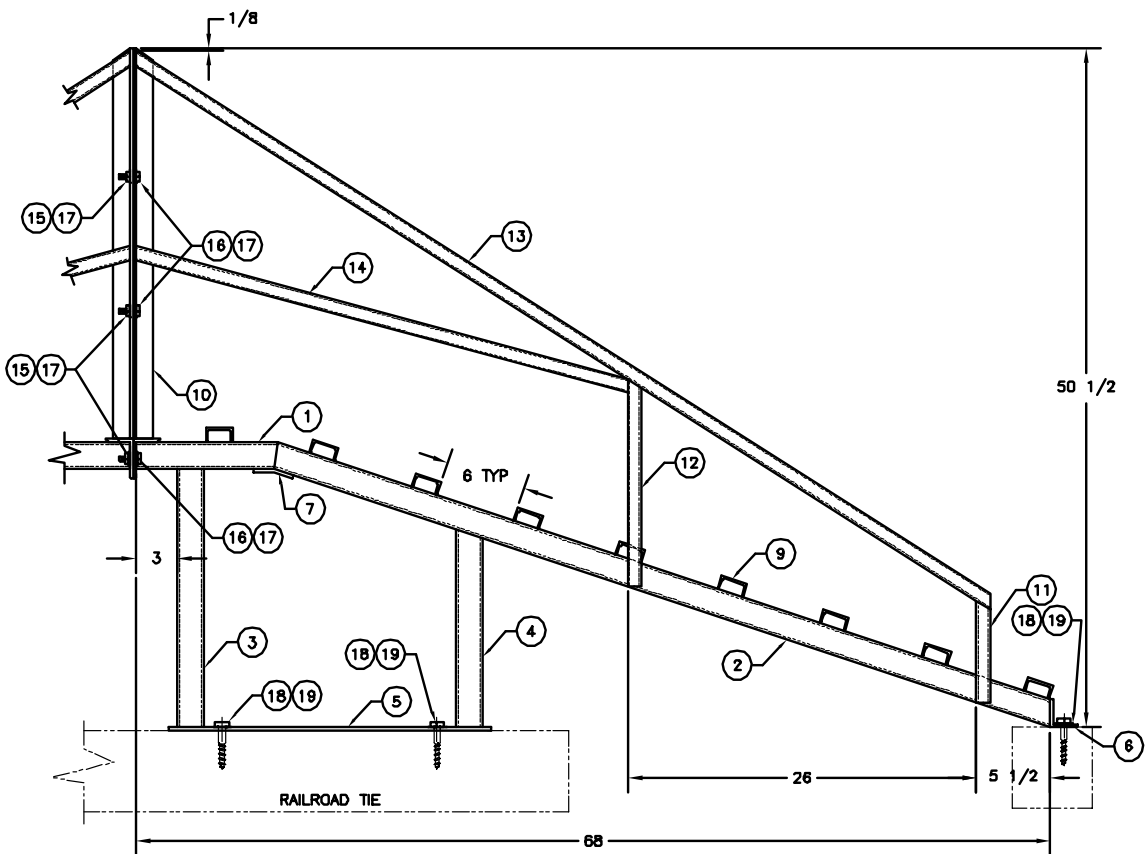
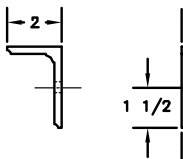

11 BOTTOM SUPPORT
SCALE X2

WELDED CONSTRUCTION

MATERIAL LIST

NO	PART NAME	REQD	MATERIAL-DESCRIPTION
1	FRAME (TOP)	3	3/16 X 2 X 10-1/2 LG SQ. MECH TUBING, STEEL
2	FRAME	3	3/16 X 2 X 61-1/4 LG SQ. MECH TUBING, STEEL
3	FRONT LEG	2	3/16 X 2 X 19-1/4 LG SQ. MECH TUBING, STEEL
4	BACK LEG	2	3/16 X 2 X 14-3/4 LG SQ. MECH TUBING, STEEL
5	BASE	2	1/4 X 3 X 24 LG FLAT, STEEL
6	TAB	2	1/4 X 2 X 2 ANGLE, STEEL
7	STIFFENER	3	1/4 X 1-1/2 X 3 LG FLAT, STEEL
8	CENTER RAIL	1	1/4 X 2 X 3 X 64 LG ANGLE, STEEL
9	TREADS	9	1/8 X 1 X 2 X 54 LG STANDARD "C" CHANNEL, STEEL
10	POST RAIL	2	3/16 X 1-1/2 X 1-1/2 X 29 LG ANGLE, STEEL
11	BOTTOM SUPPORT	2	11 GAUGE X 1 X 7-5/8 LG SQ TUBING, STEEL
12	CENTER SUPPORT	2	11 GAUGE X 1 X 16-5/8 LG SQ TUBING, STEEL
13	TOP RAIL	2	11 GAUGE X 1 X 75-1/4 LG SQ TUBING, STEEL
14	CROSS SUPPORT	2	11 GAUGE X 1 X 38-3/16 LG SQ TUBING, STEEL
15	NUT	8	3/8-16NC HEX NUT
16	BOLT	8	3/8-16NC X 1 LG HEX HEAD BOLT
17	WASHER	16	3/8-INCH FLAT WASHER
18	BOLT	6	1/2 X 3 LG HEAVY DUTY HEX HEAD LAG BOLT
19	WASHER	6	1/2-INCH FLAT WASHER

NOTES:

- PARTS SHOWN FOR 1 ASSEMBLY - 2 REQ'D.
- CATTLE GUARD SECTIONS ARE DESIGNED TO BE INSTALLED ALONG AN EXISTING FENCE LINE USING THE EXISTING POST(S) OR PLACED TOGETHER AND BOLTED ALONG THE CENTER RAIL - PART NO. 8. PARTS SHOWN ARE FOR BOLTING THE TWO SECTIONS TOGETHER.
- CENTER FRAME SECTION CAN BE CONSTRUCTED OF 3/16 X 2 X 2 ANGLE IF DESIRED.

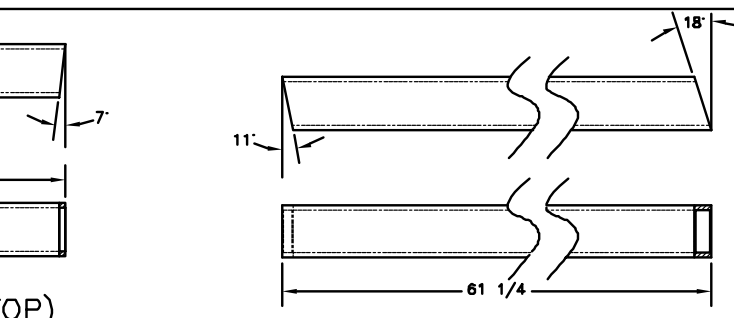

2 FRAME (SIDE)
SCALE X2

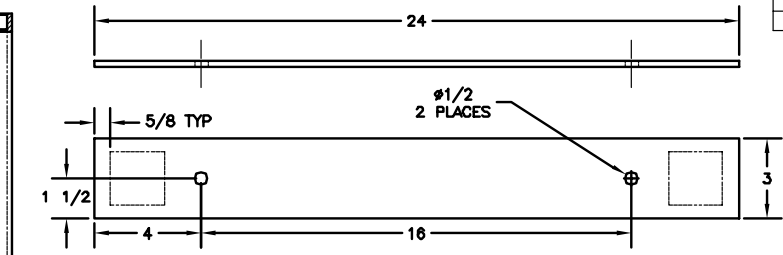

5 BASE
SCALE X2

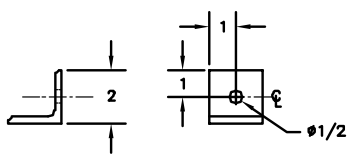

6 TAB
SCALE X2

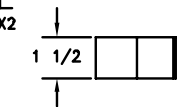

7 STIFFENER
SCALE X2

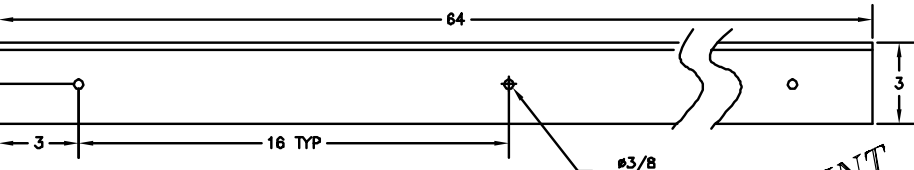

8 CENTER RAIL
SCALE X2

THIS IS A REDUCED PRINT

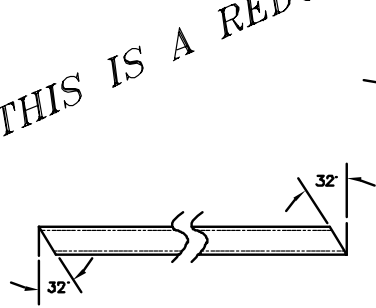

14 CROSS SUPPORT
SCALE X2

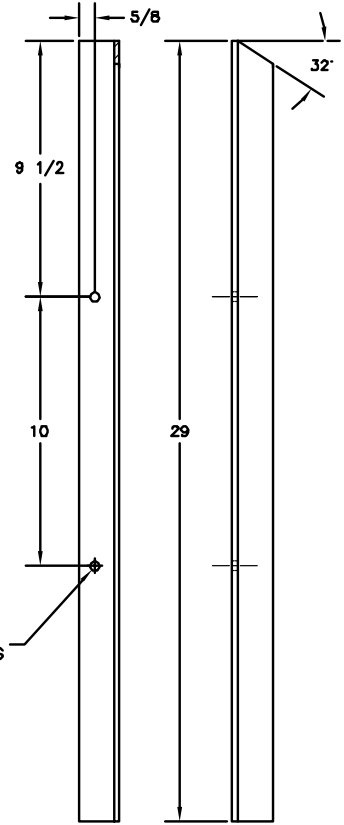

10 POST RAIL
SCALE X2

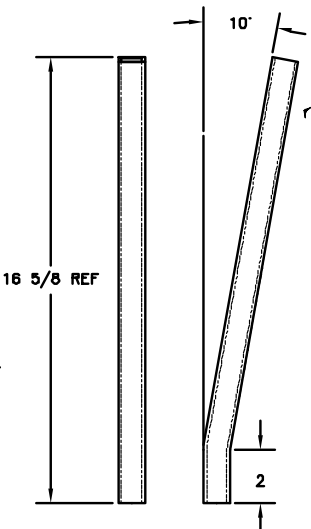

12 CENTER SUPPORT
SCALE X2

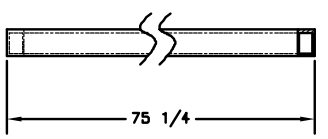

13 TOP RAIL

UNLESS OTHERWISE SPECIFIED		DATE	REVISION	BY
TOLERANCES:		U. S. DEPT. OF AGRICULTURE FOREST SERVICE		
FRACTIONS +/-		TECHNOLOGY & DEVELOPMENT CENTER		
DECIMALS +/-		MISSOULA, MT		
ANGLES +/-		TITLE		
DIMENSIONS ARE IN INCHES BREAK SHARP EDGES		SOUTHWEST MONTANA ATV TRAIL CATTLE GUARD		
DRAWN MUCCI		1049-01.dwg		
DESIGNED BEAVERHEAD-		SHEET 1 OF 1		
DEERLODGE NF, MCGREW		MTDC- .1049		
MACHINE & FABRICATING				
REVIEWED KEES				
SCALE FULL & NOTED DATE DEC 2005				

Yellow retroreflective object markers are mounted on each side of the two posts to help ATV riders see the edges of the structure after dark. Instead, markers could be placed on flexible fiberglass stakes or posts at each of the four corners of the cattle guard. The markers (figure 2) may be type 2 or modified type 2 object markers. If a cattle guard constricts or narrows the trail, the larger type 3 object markers (figure 2) may be required. In the Forest Service, a recreation review serves to document the size and type of object markers that are needed.

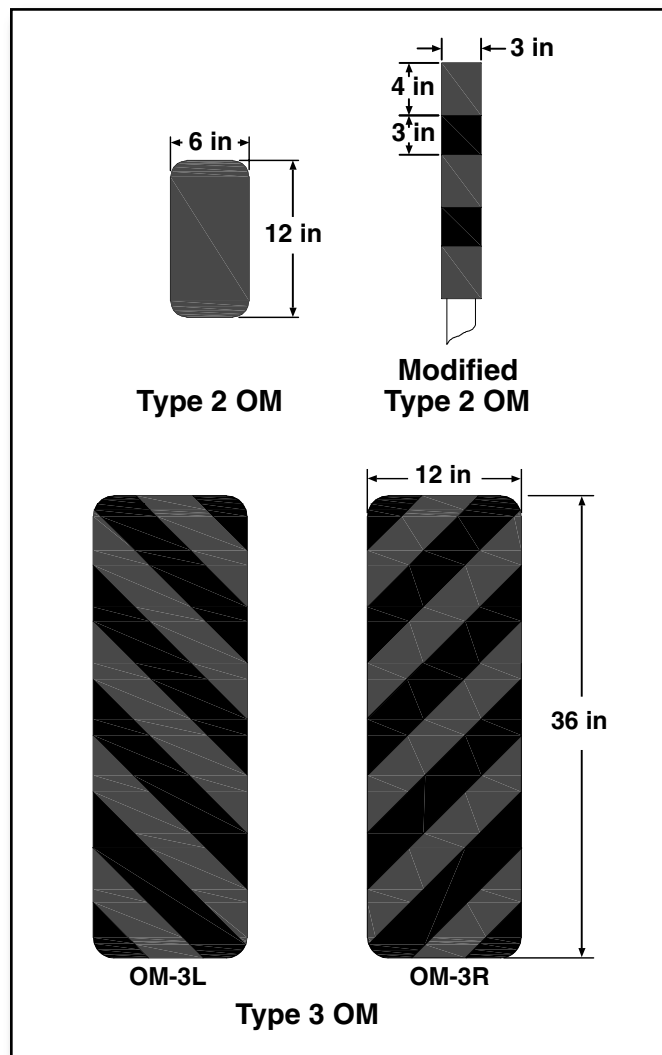

Figure 2—The type 2 or modified type 2 object markers meet Forest Service guidelines, except where the cattle guard narrows or constricts a wide trail. In such cases, the type 3 object marker may be needed as determined by a recreation review.

Availability

The cattle guard can be fabricated from the drawing on the inside pages. McGrew Machine and Fabricating, Inc., Whitehall, MT, fabricates and sells these cattle guards.

McGrew Machine and Fabricating, Inc.

5 South Division St.

Whitehall, MT 59759

Phone: 406-287-3916

Thanks to...

Grant Godbolt, Beaverhead-Deerlodge National Forest

Tim Hippert, McGrew Machine and Fabricating, Inc.

Donna Sheehy, Northern Region, USDA Forest Service

Eric Tolf, Beaverhead-Deerlodge National Forest

Additional single copies of this document may be ordered from:

USDA Forest Service, Missoula Technology and Development Center

5785 Hwy. 10 West

Missoula, MT 59808-9361

Phone: 406-329-3978

Fax: 406-329-3719

E-mail: wo_mtdc_pubs@fs.fed.us

For additional information about improved ATV trail cattle guards, contact Brian Vachowski at MTDC.

Phone: 406-329-3935

Fax: 406-329-3719

E-mail: bvachowski@fs.fed.us

Electronic copies of MTDC's documents are available on the Internet at: <http://www.fs.fed.us/eng/t-d.php/>

Forest Service and Bureau of Land Management employees can search a more complete collection of MTDC's documents, videos, and CDs on their internal computer networks at: <http://fsweb.mtdc.wo.fs.fed.us/search/>



The Forest Service, United States Department of Agriculture (USDA), has developed this information for the guidance of its employees, its contractors, and its cooperating Federal and State agencies, and is not responsible for the interpretation or use of this information by anyone except its own employees. The use of trade, firm, or corporation names in this document is for the information and convenience of the reader, and does not constitute an endorsement by the Department of any product or service to the exclusion of others that may be suitable.

The U.S. Department of Agriculture (USDA) prohibits discrimination in all its programs and activities on the basis of race, color, national origin, age, disability, and where applicable, sex, marital status, familial status, parental status, religion, sexual orientation, genetic information, political beliefs, reprisal, or because all or part of an individual's income is derived from any public assistance program. (Not all prohibited bases apply to all programs.) Persons with disabilities who require alternative means for communication of program information (Braille, large print, audiotape, etc.) should contact USDA's TARGET Center at (202) 720-2600 (voice and TDD). To file a complaint of discrimination, write to USDA, Director, Office of Civil Rights, 1400 Independence Avenue, S.W., Washington, D.C. 20250-9410, or call (800) 795-3272 (voice) or (202) 720-6382 (TDD). USDA is an equal opportunity provider and employer.