

# COMPUTER TESTING SUPPLEMENT FOR COMMERCIAL PILOT



**DO NOT MARK IN THIS BOOK**



U.S. Department of Transportation  
**Federal Aviation Administration**

**COMPUTER TESTING SUPPLEMENT  
FOR  
COMMERCIAL PILOT**

**2005**

U.S. DEPARTMENT OF TRANSPORTATION  
**FEDERAL AVIATION ADMINISTRATION**

Flight Standards Service



## PREFACE

This computer testing supplement is designed by the Flight Standards Service of the Federal Aviation Administration (FAA) for use by computer testing designees (CTDs) and testing centers in the administration of airman knowledge tests in the following knowledge areas:

Commercial Pilot—Airplane (CAX)  
Commercial Pilot—Glider (CGX)  
Commercial Pilot—Lighter-Than-Air—Airship (CLA)  
Commercial Pilot—Rotorcraft/Gyroplane (CRG)  
Commercial Pilot—Rotorcraft/Helicopter (CRH)  
Commercial Pilot—Balloon Gas (CBG)  
Commercial Pilot—Balloon—Hot Air (CBH)  
Military Competence—Airplane (MCA)  
Military Competence—Rotorcraft/Helicopter (MCH)

FAA-CT-8080-1C supercedes FAA-CT-8080-1B, Computer Testing Supplement for Commercial Pilot, dated 1998.

Comments regarding this supplement should be sent to:

U.S. Department of Transportation  
Federal Aviation Administration  
Flight Standards Service  
Airman Testing Standards Branch, AFS-630  
P.O. Box 25082  
Oklahoma City, OK 73125





# CONTENTS

Preface .....	iii
Contents .....	v
FIGURE 1.—Drag vs. Speed .....	1
FIGURE 2.—Stall Speeds .....	1
FIGURE 3.—Angle of Attack, Degrees .....	2
FIGURE 4.—Stall Speed/Load Factor .....	3
FIGURE 5.—Velocity vs. G-Loads .....	4
FIGURE 6.—Adiabatic Chart .....	5
FIGURE 7.—Stability Chart .....	6
FIGURE 8.—Fuel Consumption vs. Brake Horsepower .....	7
FIGURE 9.—Fuel, Time, and Distance to Climb .....	8
FIGURE 10.—Fuel, Time, and Distance to Climb .....	9
FIGURE 11.—Cruise and Range Performance .....	10
FIGURE 12.—Cruise Performance .....	11
FIGURE 13.—Fuel, Time, and Distance to Climb .....	12
FIGURE 14.—Fuel, Time, and Distance to Climb .....	13
FIGURE 15.—Fuel, Time, and Distance to Climb .....	14
FIGURE 16.—Magnetic Compass/ADF .....	15
FIGURE 17.—Horizontal Situation Indicator (HSI) .....	16
FIGURE 18.—Magnetic Heading/Radio Compass .....	17
FIGURE 19.—Magnetic Heading/Radio Compass .....	17
FIGURE 20.—Radio Magnetic Indicator (RMI) .....	18
FIGURE 21.—Isosceles Triangle .....	19
FIGURE 22.—Isosceles Triangle .....	19
FIGURE 23.—Isosceles Triangle .....	20
FIGURE 24.—Isosceles Triangle .....	20
FIGURE 25.—ILS RWY 13L (DSM) .....	21
FIGURE 26.—ILS RWY 24R (LAX) .....	22
FIGURE 27.—ILS/DME RWY 35R (DEN) .....	23
FIGURE 28.—ILS RWY 31R (DSM) .....	24
FIGURE 29.—ILS RWY 8L (ATL) .....	25
FIGURE 30.—VOR/DME—A (7D3) .....	26
FIGURE 31.—Wind Component Chart .....	27
FIGURE 32.—Obstacle Take-off Chart .....	28
FIGURE 33.—Maximum Rate-of-Climb Chart .....	29
FIGURE 34.—Cruise Performance Chart .....	30
FIGURE 35.—Normal Landing Chart .....	31
FIGURE 36.—Stations Diagram .....	32
FIGURE 37.—Center-of-Gravity Envelope and Loading Graph .....	33
FIGURE 38.—Loading Graph and Center-of-Gravity Envelope .....	34
FIGURE 39.—Stations Diagram .....	35
FIGURE 40.—Weight and Balance Chart .....	36
FIGURE 41.—Hover Ceiling vs. Gross Weight .....	37
FIGURE 42.—Rate of Climb (Ft/Min) .....	38
FIGURE 43.—Best Rate-of-Climb Speed .....	39
FIGURE 44.—Rate of Climb .....	40

## CONTENTS—Continued

FIGURE 45.—Running Takeoff .....	41
FIGURE 46.—Jump Takeoff .....	42
FIGURE 47.—(Withdrawn) PAGE INTENTIONALLY LEFT BLANK .....	43
FIGURE 48.—Performance Curves Chart .....	44
FIGURE 49.—Performance Curves Chart .....	45
FIGURE 50.—Flight Envelope .....	46
FIGURE 51.—Airport Signs .....	47
FIGURE 52.—Sectional Chart Excerpt .....	48
FIGURE 53.—Sectional Chart Excerpt .....	49
FIGURE 54.—Sectional Chart Excerpt .....	50
FIGURE 55.—En Route Low Altitude Chart Segment .....	51
FIGURE 56.—Two Signs .....	52
FIGURE 57.—Sign .....	52
FIGURE 58.—Airport Diagram and Sign .....	52
FIGURE 59.—Taxiway Diagram and Sign .....	53
FIGURE 60.—Two Signs .....	53
FIGURE 61.—Sign .....	54
FIGURE 62.—Sign .....	54
FIGURE 63.—Sign and Intersection Diagram .....	54
FIGURE 64.—Sign .....	55
FIGURE 65.—Sign .....	55

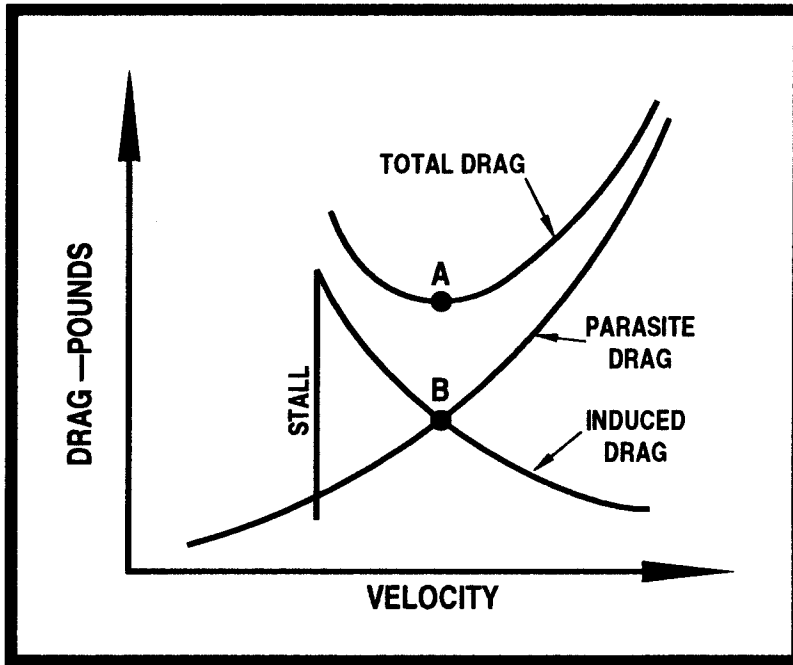

FIGURE 1.—Drag vs. Speed.

GROSS WEIGHT 2750 LBS		ANGLE OF BANK			
		LEVEL	30°	45°	60°
	POWER	GEAR AND FLAPS UP			
ON	MPH	62	67	74	88
	KTS	54	58	64	76
OFF	MPH	75	81	89	106
	KTS	65	70	77	92
		GEAR AND FLAPS DOWN			
ON	MPH	54	58	64	76
	KTS	47	50	56	66
OFF	MPH	66	71	78	93
	KTS	57	62	68	81

FIGURE 2.—Stall Speeds.

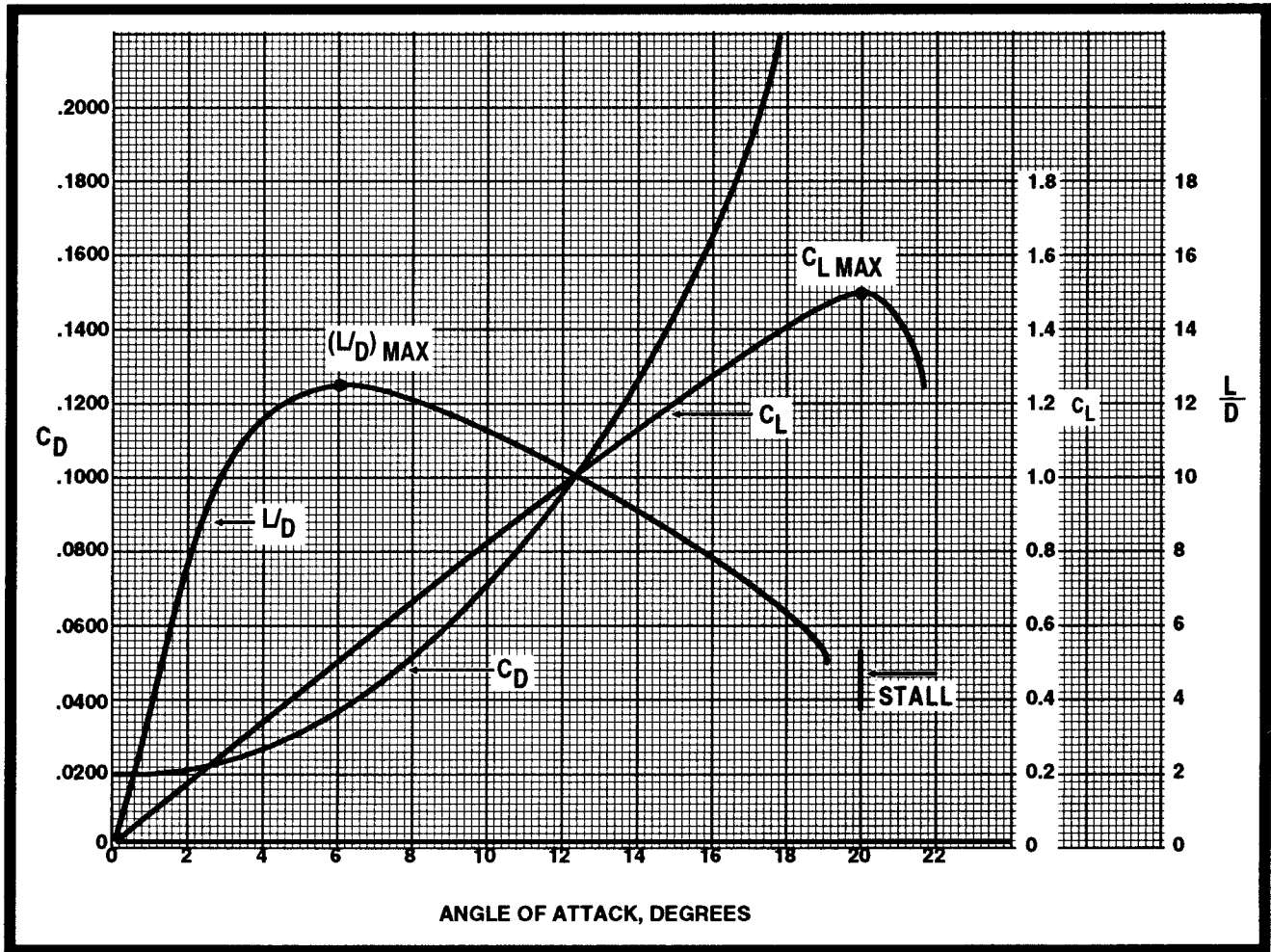

FIGURE 3.—Angle of Attack, Degrees.

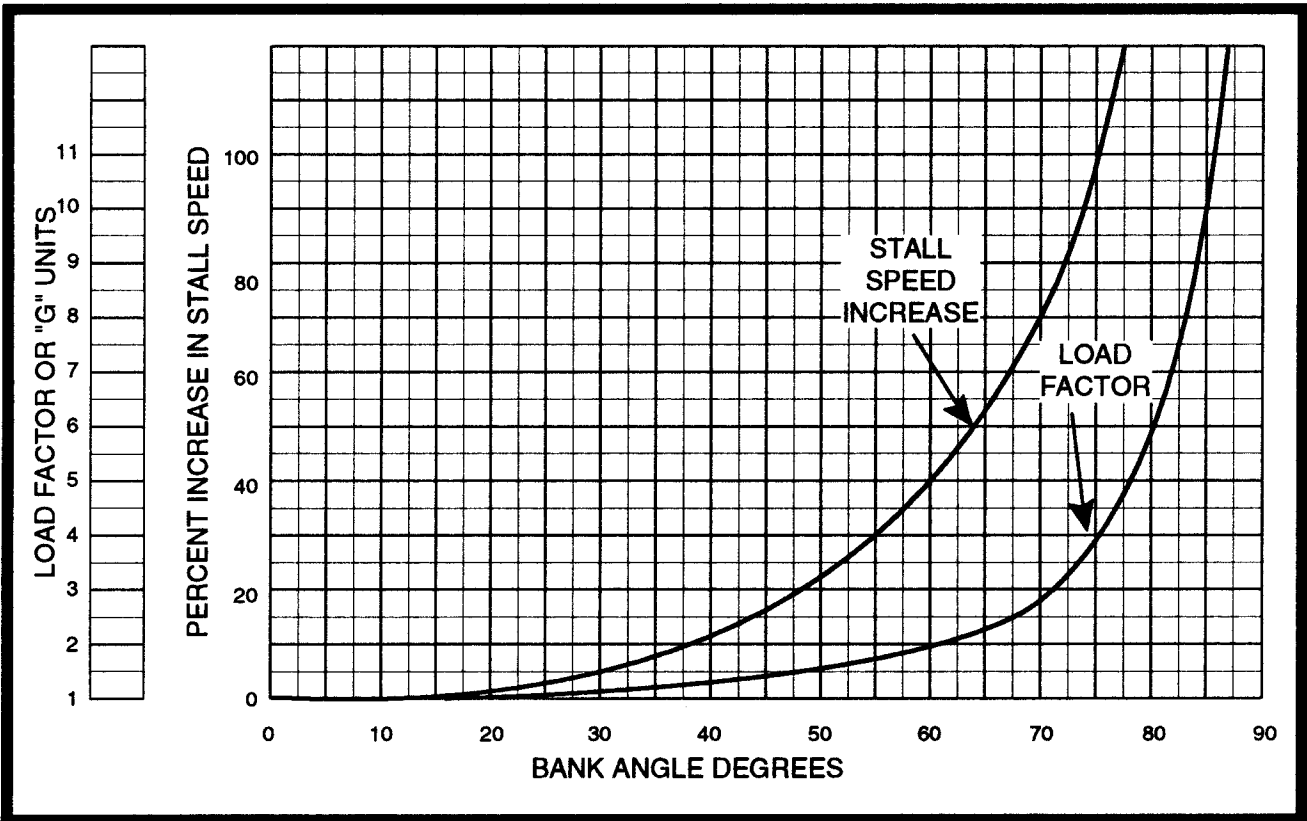

FIGURE 4.—Stall Speed/Load Factor.

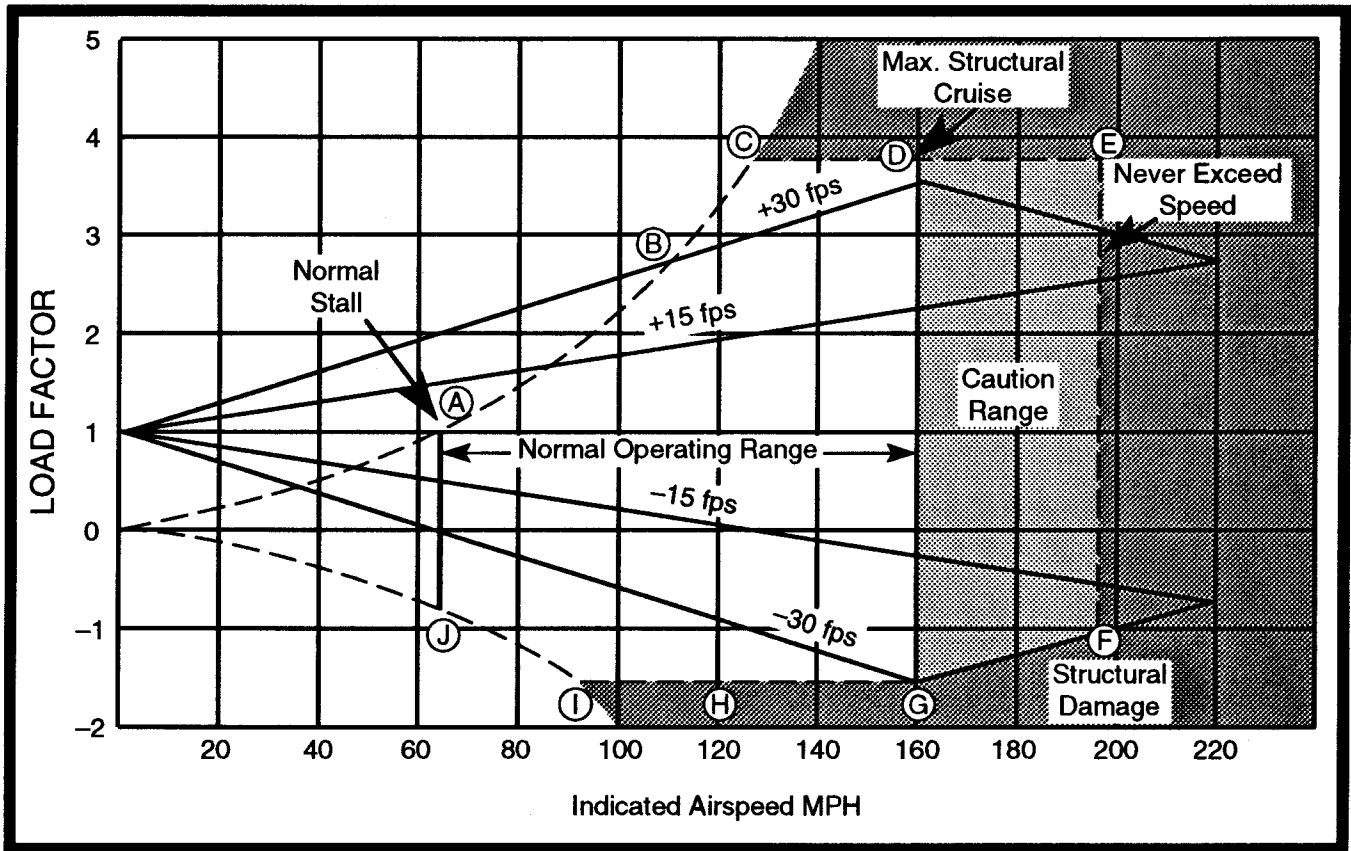

FIGURE 5.—Velocity vs. G-Loads.

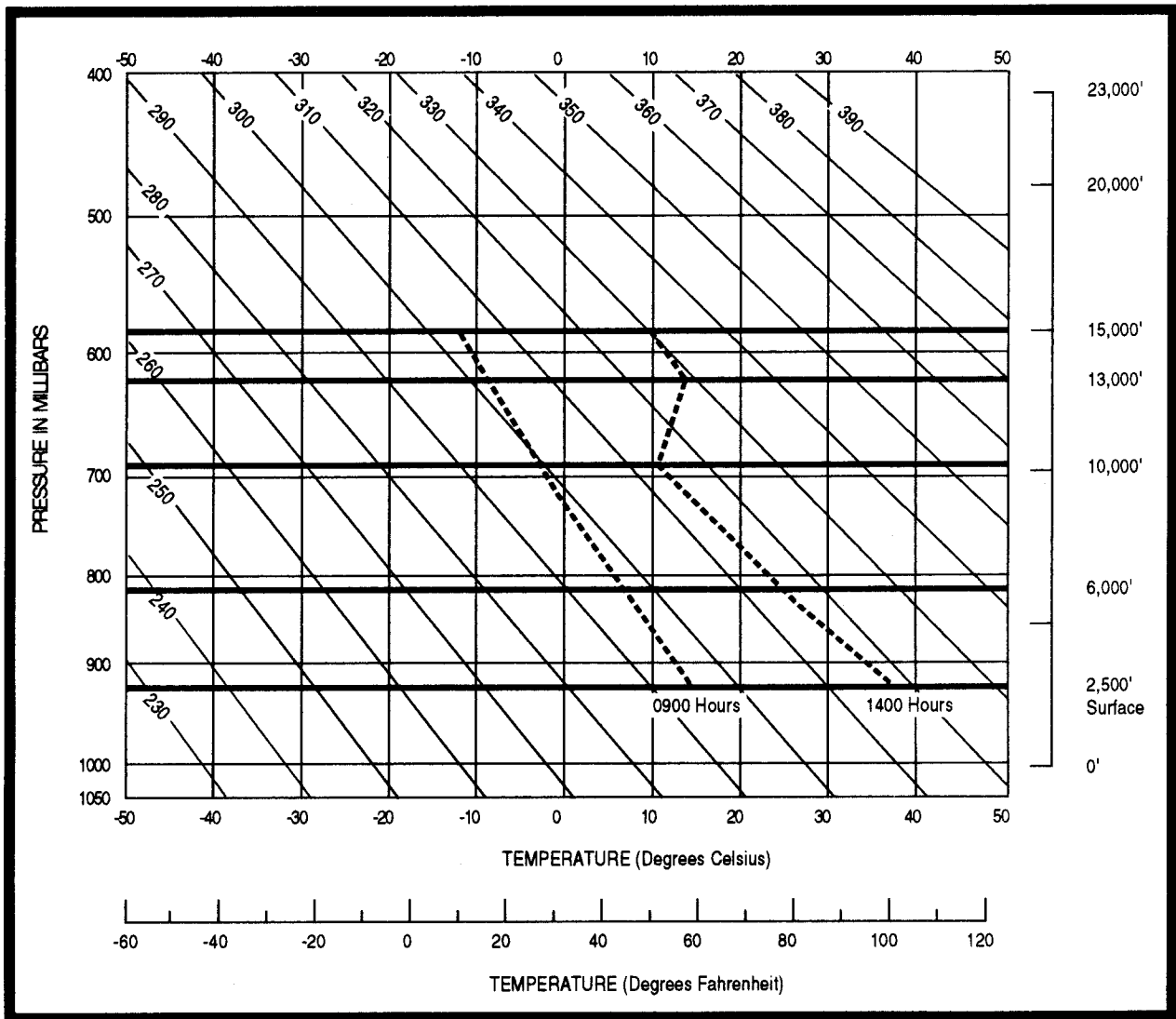

FIGURE 6.—Adiabatic Chart.



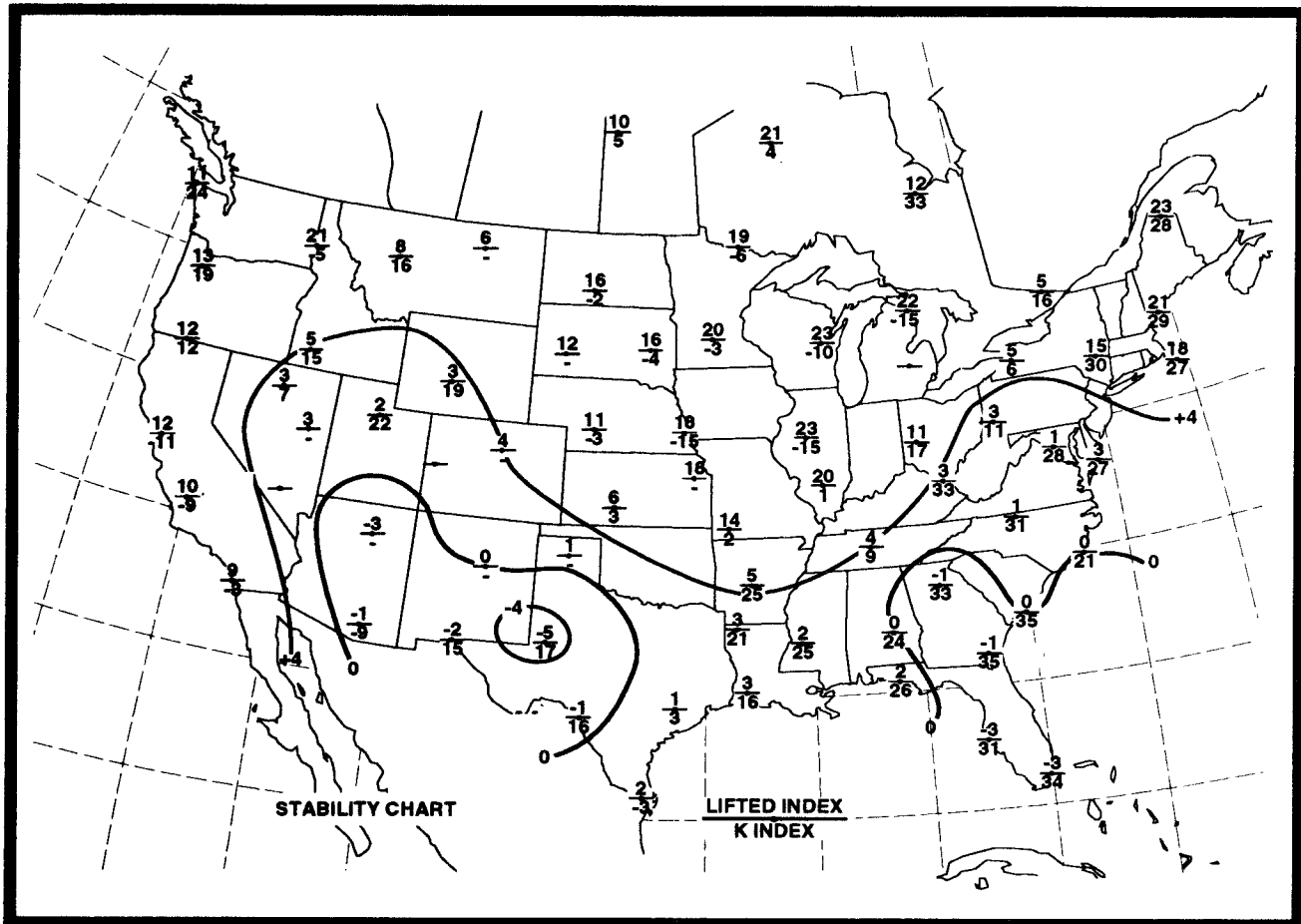

FIGURE 7.—Stability Chart.

NOTE:  
 TAKEOFF AND CLIMB FUEL FLOW  
 PROVIDES ADDITIONAL COOLING IN  
 HIGH AMBIENT TEMPERATURES

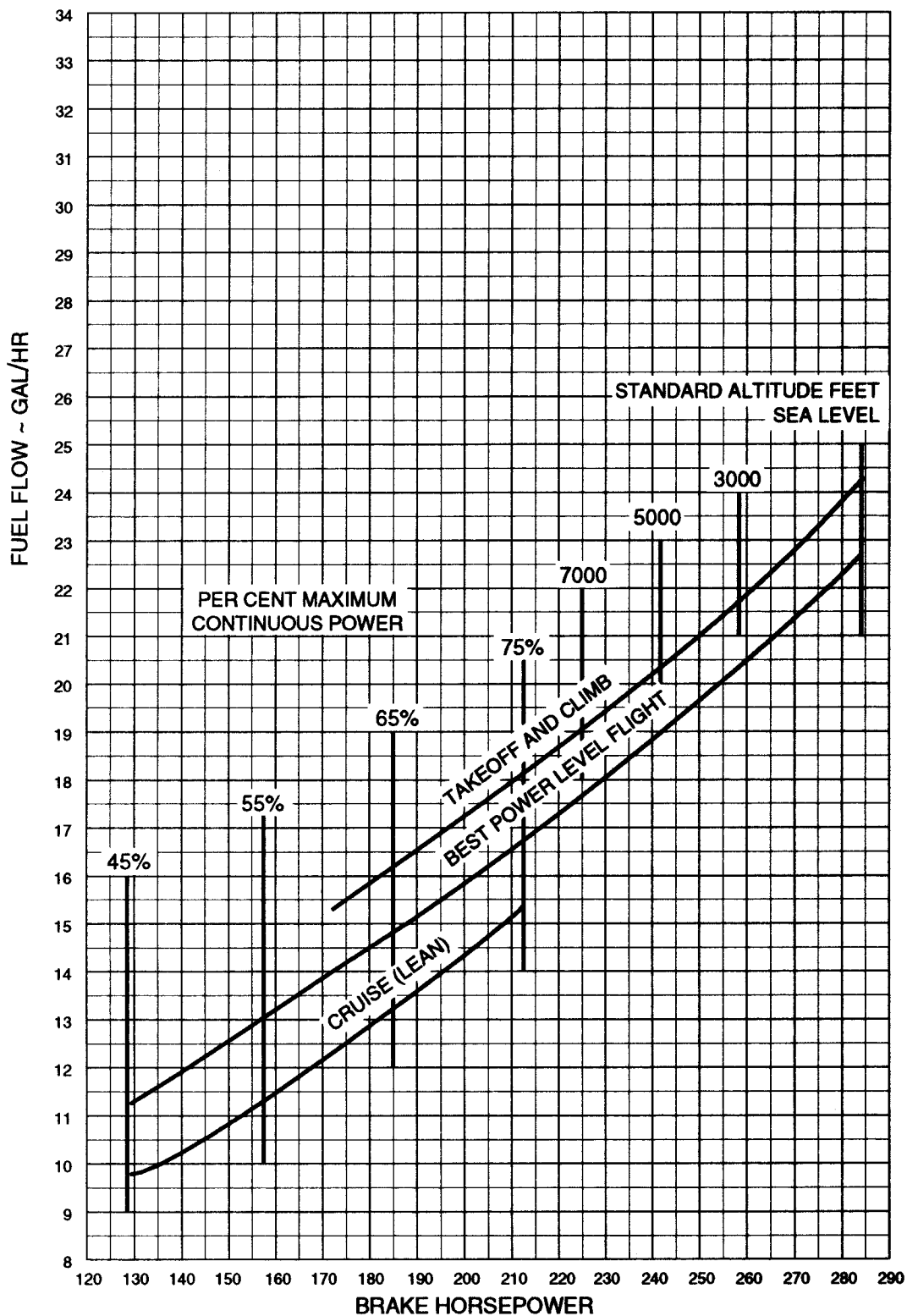

FIGURE 8.—Fuel Consumption vs. Brake Horsepower.

## NORMAL CLIMB – 100 KIAS

**CONDITIONS:**

Flaps Up  
 Gear Up  
 2550 RPM  
 25 Inches MP or Full Throttle  
 Cowl Flaps Open  
 Standard Temperature

MIXTURE SETTING	
PRESS ALT	PPH
S.L. to 4000	108
8000	96
12,000	84

**NOTES:**

1. Add 12 pounds of fuel for engine start, taxi and takeoff allowance.
2. Increase time, fuel and distance by 10% for each 10 °C above standard temperature.
3. Distances shown are based on zero wind.

WEIGHT LBS	PRESS ALT FT	RATE OF CLIMB FPM	FROM SEA LEVEL		
			TIME MIN	FUEL USED POUNDS	DISTANCE NM
3800	S.L.	580	0	0	0
	2000	580	3	6	6
	4000	570	7	12	12
	6000	470	11	19	19
	8000	365	16	27	28
	10,000	265	22	37	40
	12,000	165	32	51	59
3500	S.L.	685	0	0	0
	2000	685	3	5	5
	4000	675	6	11	10
	6000	565	9	16	16
	8000	455	13	23	23
	10,000	350	18	31	33
	12,000	240	25	41	46
3200	S.L.	800	0	0	0
	2000	800	2	4	4
	4000	795	5	9	8
	6000	675	8	14	13
	8000	560	11	19	19
	10,000	445	15	25	27
	12,000	325	20	33	37

**FIGURE 9.—Fuel, Time, and Distance to Climb.**

## MAXIMUM RATE OF CLIMB

**CONDITIONS:**

Flaps Up  
 Gear Up  
 2700 RPM  
 Full Throttle  
 Mixture Set at Placard Fuel Flow  
 Cowl Flaps Open  
 Standard Temperature

MIXTURE SETTING	
PRESS ALT	PPH
S.L.	138
4000	126
8000	114
12,000	102

**NOTES:**

1. Add 12 pounds of fuel for engine start, taxi and takeoff allowance.
2. Increase time, fuel and distance by 10% for each 10 °C above standard temperature.
3. Distances shown are based on zero wind.

WEIGHT LBS	PRESS ALT FT	CLIMB SPEED KIAS	RATE OF CLIMB FPM	FROM SEA LEVEL		
				TIME MIN	FUEL USED POUNDS	DISTANCE NM
3800	S.L.	97	860	0	0	0
	2000	95	760	2	6	4
	4000	94	660	5	12	9
	6000	93	565	9	18	14
	8000	91	465	13	26	21
	10,000	90	365	18	35	29
	12,000	89	265	24	47	41
3500	S.L.	95	990	0	0	0
	2000	94	885	2	5	3
	4000	93	780	5	10	7
	6000	91	675	7	16	12
	8000	90	570	11	22	17
	10,000	89	465	15	29	24
	12,000	87	360	20	38	32
3200	S.L.	94	1135	0	0	0
	2000	92	1020	2	4	3
	4000	91	910	4	9	6
	6000	90	800	6	14	10
	8000	88	685	9	19	14
	10,000	87	575	12	25	20
	12,000	86	465	16	32	26

**FIGURE 10.—Fuel, Time, and Distance to Climb.**

Gross Weight- 2300 Lbs.  
Standard Conditions  
Zero Wind Lean Mixture

NOTE: Maximum cruise is normally limited to 75% power.

ALT.	RPM	% BHP	TAS MPH	GAL/HOUR	38 GAL (NO RESERVE)		48 GAL (NO RESERVE)	
					ENDR. HOURS	RANGE MILES	ENDR. HOURS	RANGE MILES
2500	2700	86	134	9.7	3.9	525	4.9	660
	2600	79	129	8.6	4.4	570	5.6	720
	2500	72	123	7.8	4.9	600	6.2	760
	2400	65	117	7.2	5.3	620	6.7	780
	2300	58	111	6.7	5.7	630	7.2	795
	2200	52	103	6.3	6.1	625	7.7	790
5000	2700	82	134	9.0	4.2	565	5.3	710
	2600	75	128	8.1	4.7	600	5.9	760
	2500	68	122	7.4	5.1	625	6.4	790
	2400	61	116	6.9	5.5	635	6.9	805
	2300	55	108	6.5	5.9	635	7.4	805
	2200	49	100	6.0	6.3	630	7.9	795
7500	2700	78	133	8.4	4.5	600	5.7	755
	2600	71	127	7.7	4.9	625	6.2	790
	2500	64	121	7.1	5.3	645	6.7	810
	2400	58	113	6.7	5.7	645	7.2	820
	2300	52	105	6.2	6.1	640	7.7	810
10,000	2650	70	129	7.6	5.0	640	6.3	810
	2600	67	125	7.3	5.2	650	6.5	820
	2500	61	118	6.9	5.5	655	7.0	830
	2400	55	110	6.4	5.9	650	7.5	825
	2300	49	100	6.0	6.3	635	8.0	800

FIGURE 11.—Cruise and Range Performance.

## PRESSURE ALTITUDE 18,000 FEET

CONDITIONS:  
 4000 Pounds  
 Recommended Lean Mixture  
 Cowl Flaps Closed

**NOTE**

For best fuel economy at 70% power or less, operate at 6 PPH leaner than shown in this chart or at peak EGT.

		20 °C BELOW STANDARD TEMP -41 °C			STANDARD TEMPERATURE -21 °C			20 °C ABOVE STANDARD TEMP -1 °C		
RPM	MP	% BHP	KTAS	PPH	% BHP	KTAS	PPH	% BHP	KTAS	PPH
2500	30	---	---	---	81	188	106	76	185	100
	28	80	184	105	76	182	99	71	178	93
	26	75	178	99	71	176	93	67	172	88
	24	70	171	91	66	168	86	62	164	81
	22	63	162	84	60	159	79	56	155	75
2400	30	81	185	107	77	183	101	72	180	94
	28	76	179	100	72	177	94	67	173	88
	26	71	172	93	67	170	88	63	166	83
	24	66	165	87	62	163	82	58	159	77
	22	61	158	80	57	155	76	54	150	72
2300	30	79	182	103	74	180	97	70	176	91
	28	74	176	97	70	174	91	65	170	86
	26	69	170	91	65	167	86	61	163	81
	24	64	162	84	60	159	79	56	155	75
	22	58	154	77	55	150	73	51	145	65
2200	26	66	166	87	62	163	82	58	159	77
	24	61	158	80	57	154	76	54	150	72
	22	55	148	73	51	144	69	48	138	66
	20	49	136	66	46	131	63	43	124	59

FIGURE 12.—Cruise Performance.

### MAXIMUM RATE OF CLIMB

CONDITIONS:  
 Flaps Up  
 Gear Up  
 2600 RPM  
 Cowl Flaps Open  
 Standard Temperature

PRESS ALT	MP	PPH
S.L. TO 17,000	35	162
18,000	34	156
20,000	32	144
22,000	30	132
24,000	28	120

**NOTES:**

1. Add 16 pounds of fuel for engine start, taxi and takeoff allowance.
2. Increase time, fuel and distance by 10% for each 10 °C above standard temperature.
3. Distances shown are based on zero wind.

WEIGHT LBS	PRESS ALT FT	CLIMB SPEED KIAS	RATE OF CLIMB FPM	FROM SEA LEVEL		
				TIME MIN	FUEL USED POUNDS	DISTANCE NM
4000	S.L.	100	930	0	0	0
	4000	100	890	4	12	7
	8000	100	845	9	24	16
	12,000	100	790	14	38	25
	16,000	100	720	19	52	36
	20,000	99	515	26	69	50
	24,000	97	270	37	92	74
3700	S.L.	99	1060	0	0	0
	4000	99	1020	4	10	6
	8000	99	975	8	21	13
	12,000	99	915	12	33	21
	16,000	99	845	17	45	30
	20,000	97	630	22	59	42
	24,000	95	370	30	77	60
3400	S.L.	97	1205	0	0	0
	4000	97	1165	3	9	5
	8000	97	1120	7	19	12
	12,000	97	1060	11	29	18
	16,000	97	985	15	39	26
	20,000	96	760	19	51	36
	24,000	94	485	26	65	50

**FIGURE 13.—Fuel, Time, and Distance to Climb.**

**NORMAL CLIMB – 110 KIAS**

**CONDITIONS:**

Flaps Up  
 Gear Up  
 2500 RPM  
 30 Inches Hg  
 120 PPH Fuel Flow  
 Cowl Flaps Open  
 Standard Temperature

**NOTES:**

1. Add 16 pounds of fuel for engine start, taxi and takeoff allowance.
2. Increase time, fuel and distance by 10% for each 7 °C above standard temperature.
3. Distances shown are based on zero wind.

WEIGHT LBS	PRESS ALT FT	RATE OF CLIMB FPM	FROM SEA LEVEL		
			TIME MIN	FUEL USED POUNDS	DISTANCE NM
4000	S.L.	605	0	0	0
	4000	570	7	14	13
	8000	530	14	28	27
	12,000	485	22	44	43
	16,000	430	31	62	63
	20,000	365	41	82	87
3700	S.L.	700	0	0	0
	4000	665	6	12	11
	8000	625	12	24	23
	12,000	580	19	37	37
	16,000	525	26	52	53
	20,000	460	34	68	72
3400	S.L.	810	0	0	0
	4000	775	5	10	9
	8000	735	10	21	20
	12,000	690	16	32	31
	16,000	635	22	44	45
	20,000	565	29	57	61

**FIGURE 14.—Fuel, Time, and Distance to Climb.**



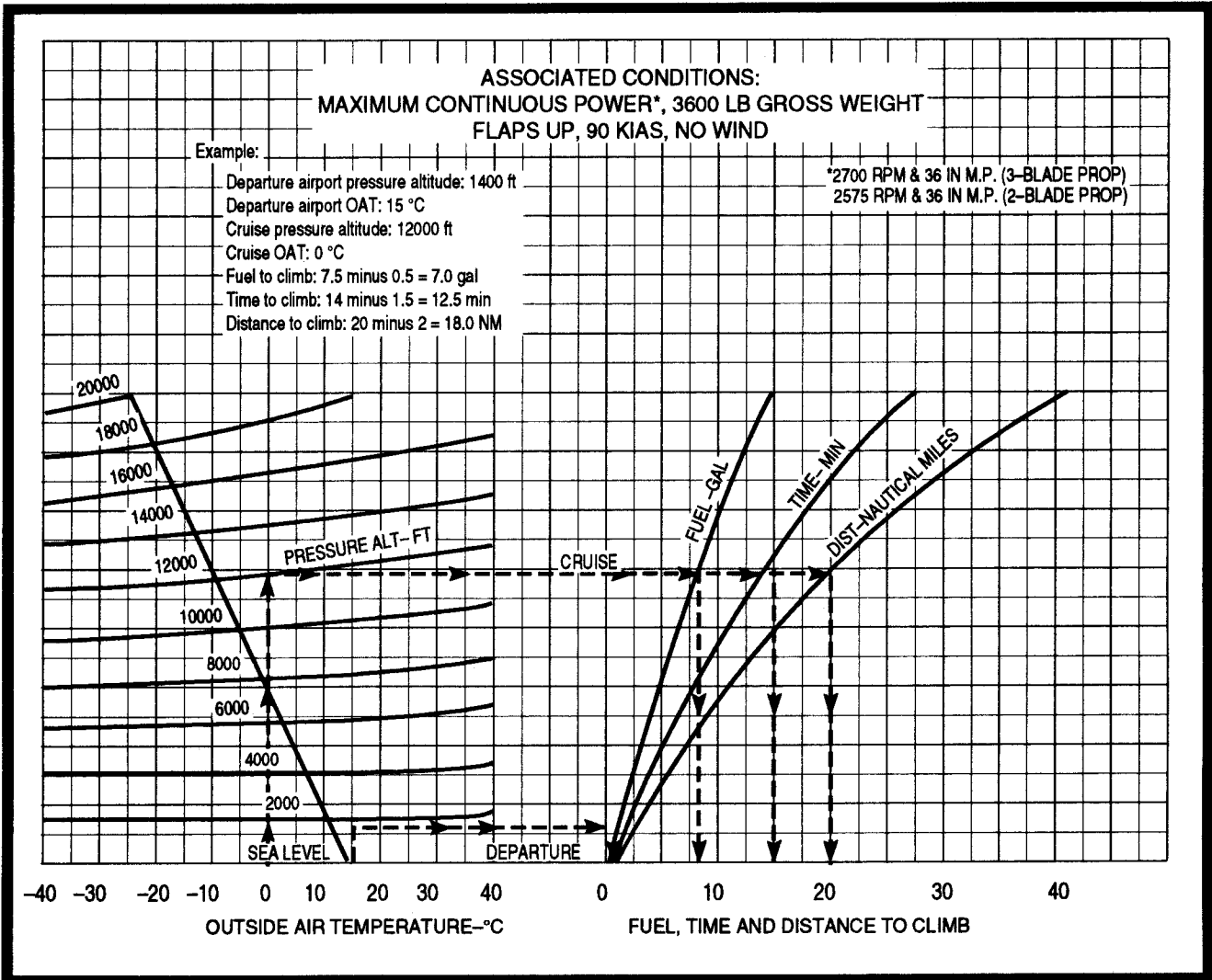

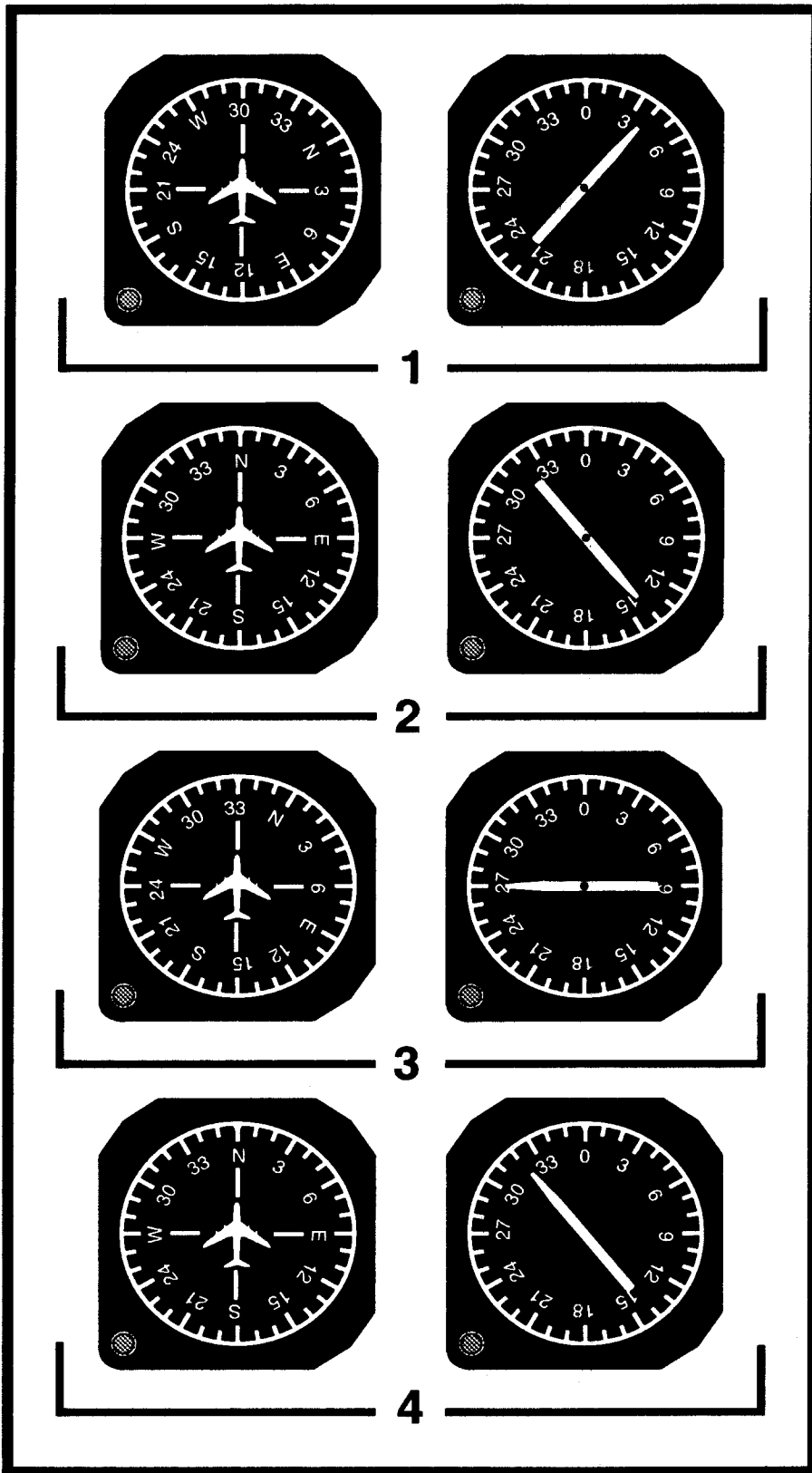

FIGURE 16.—Magnetic Compass/ADF.

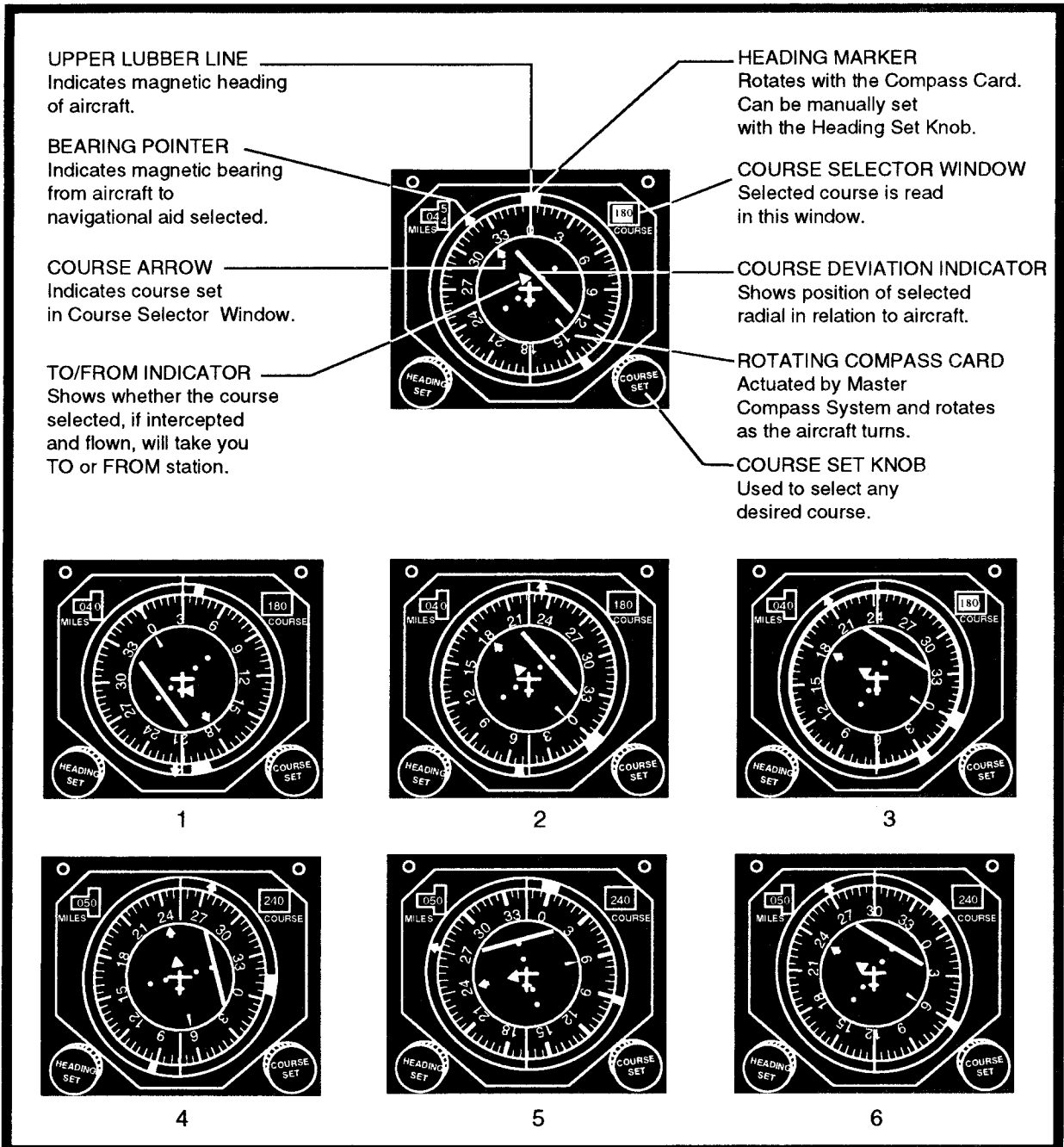

FIGURE 17.—Horizontal Situation Indicator (HSI).

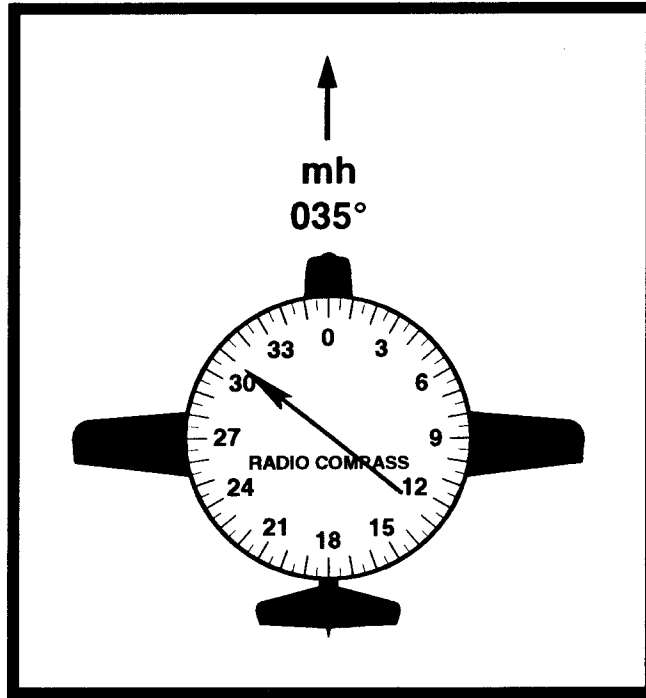

FIGURE 18.—Magnetic Heading/Radio Compass.

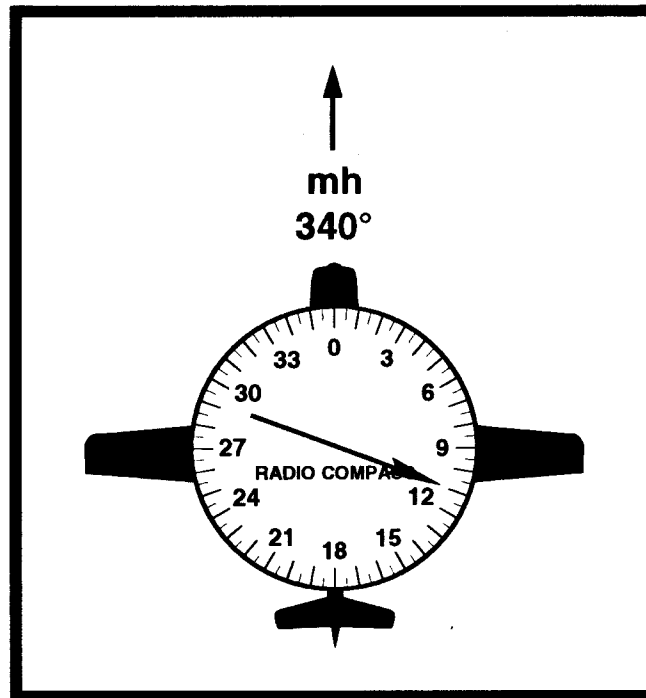

FIGURE 19.—Magnetic Heading/Radio Compass.

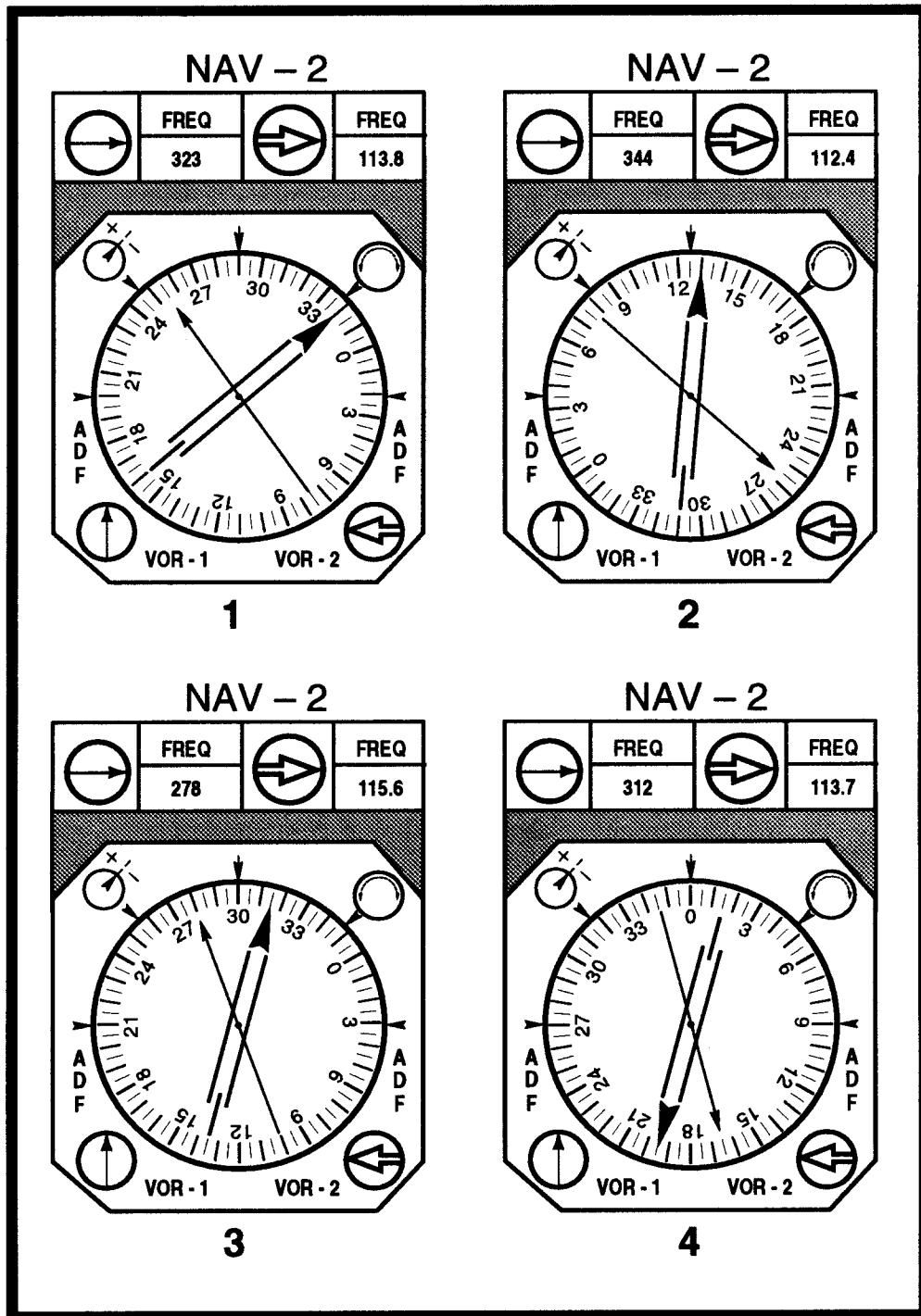

FIGURE 20.—Radio Magnetic Indicator (RMI).

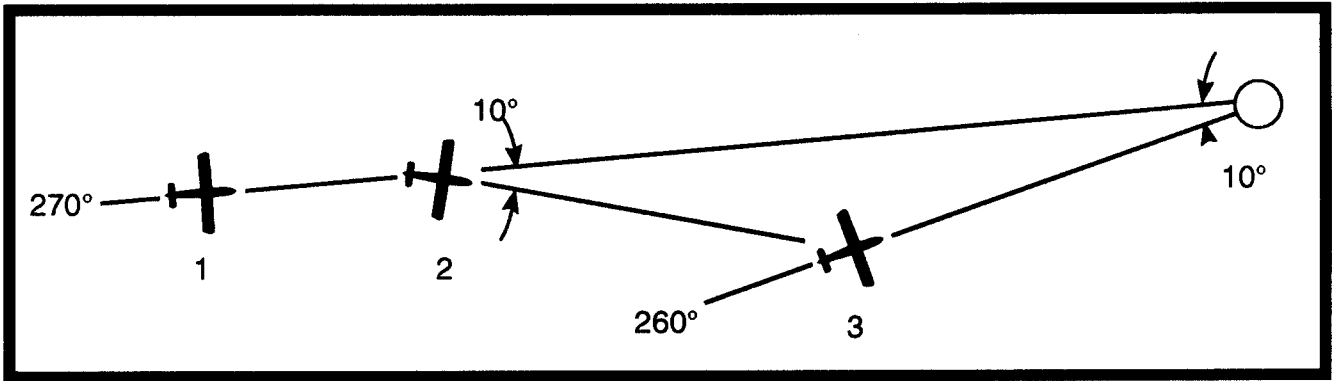

FIGURE 21.—Isosceles Triangle.

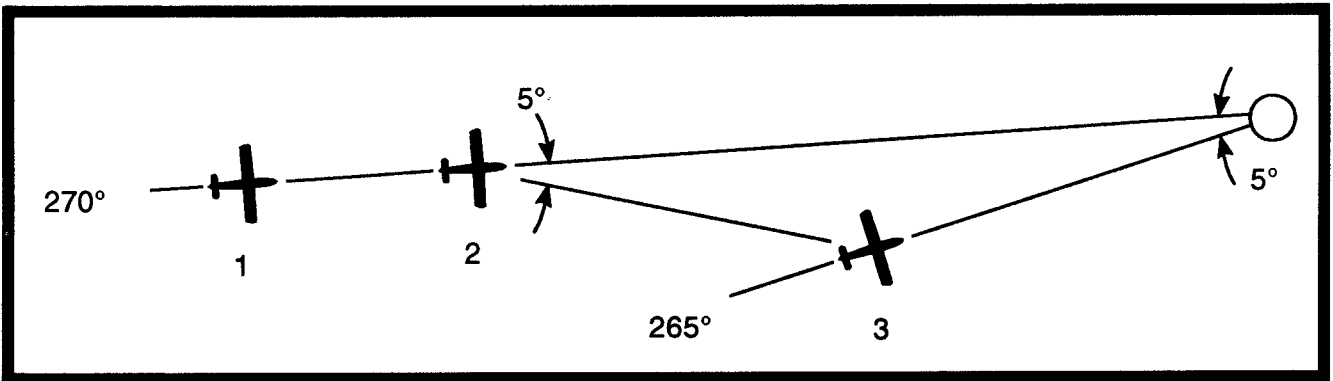

FIGURE 22.—Isosceles Triangle.

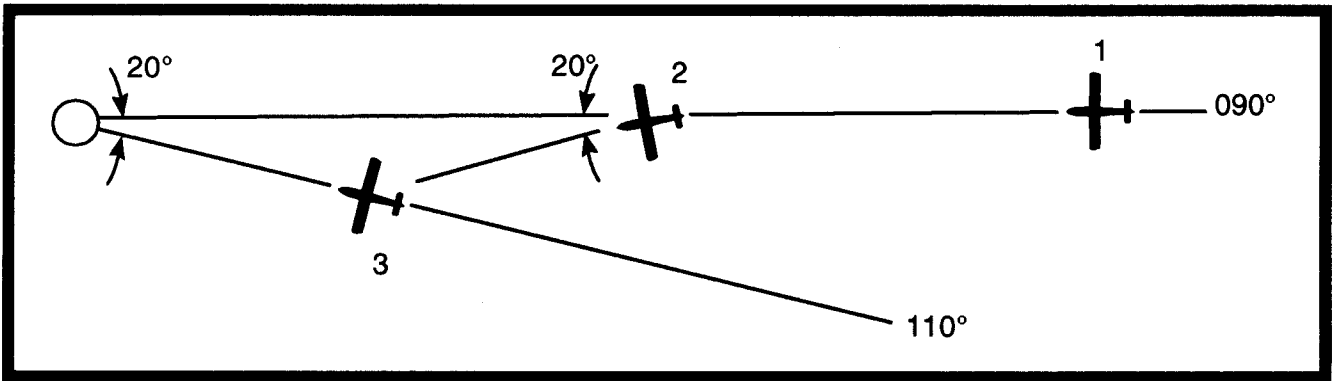

FIGURE 23.—Isosceles Triangle.

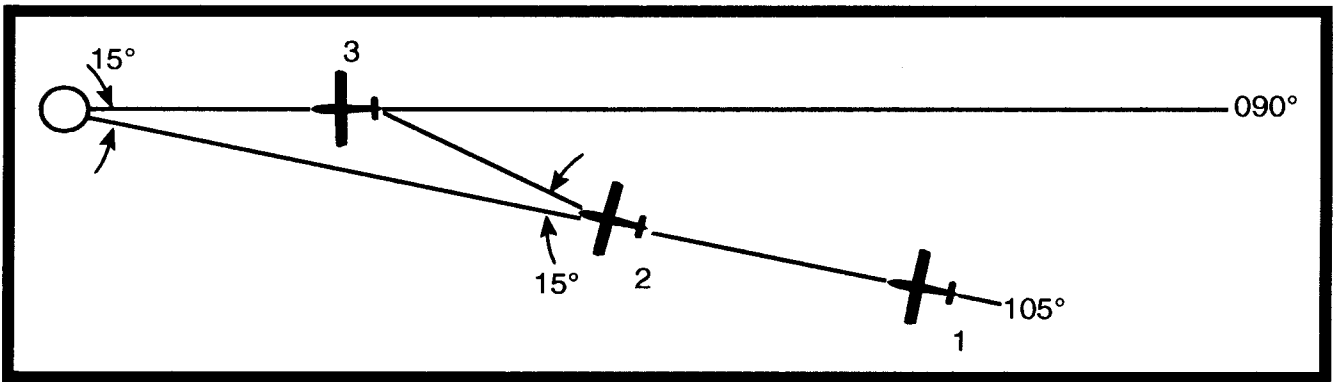

FIGURE 24.—Isosceles Triangle.

Amdt 7 97254

# ILS RWY 13L

AL-117 (FAA)

DES MOINES INTL (DSM)

DES MOINES, IOWA  
 ATIS 119.55 283.0  
 DES MOINES APP CON  
 135.2 360.7  
 DES MOINES TOWER  
 118.3 257.8  
 GND CON  
 121.9 348.6  
 CLNC DEL 134.15 321.1

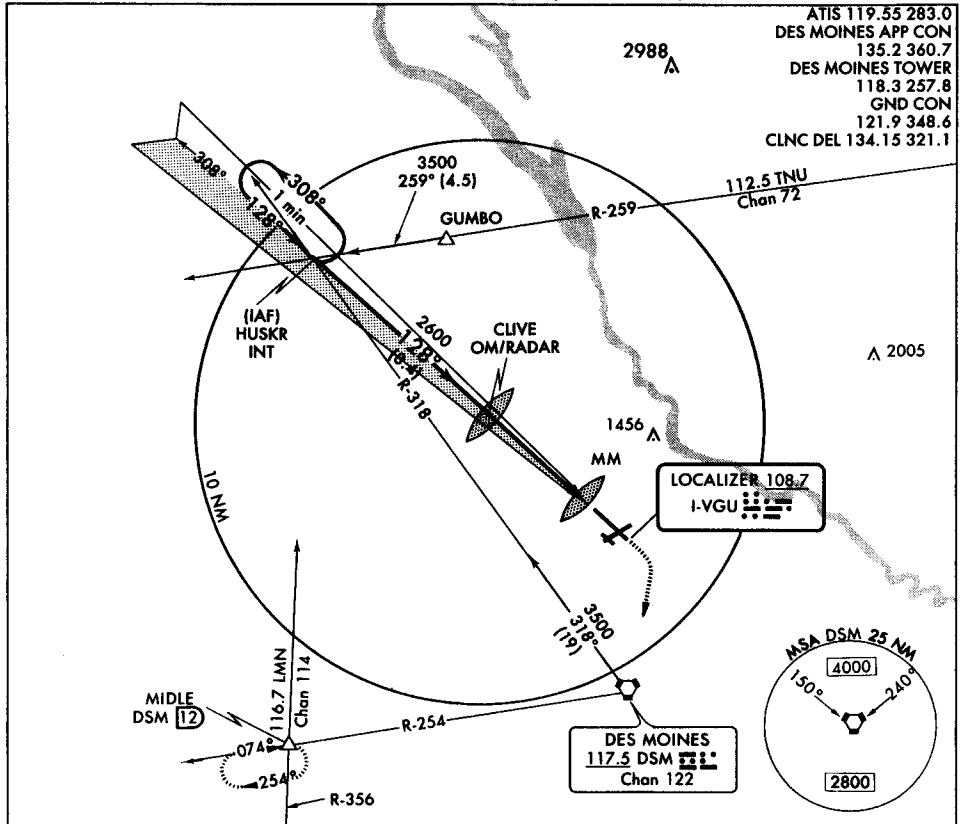

One Minute Holding Pattern

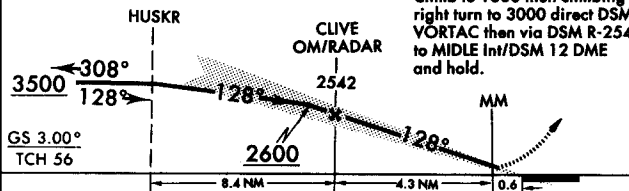

CATEGORY	A	B	C	D
S-ILS 13L	1121/24 200 (200-½)			
S-LOC 13L	1340/24	419 (400-½)	1340/40	419 (400-¾)
CIRCLING	1380-1 423 (500-1)	1420-1 463 (500-1)	1420-1½ 463 (500-1½)	1520-2 563 (600-2)

ELEV 957

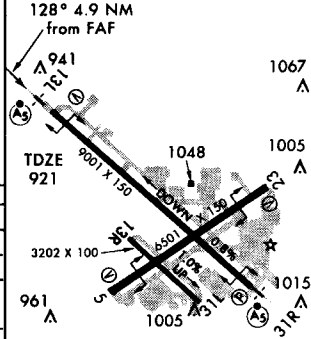

HIRL Rwy 13L-31R  
 MIRL Rwys 5-23 and 13R-31L  
 REIL Rwys 5, 13R, 23, and 31L

FAF to MAP 4.9 NM					
Knots	60	90	120	150	180
Min:Sec	4:54	3:16	2:27	1:58	1:38

# ILS RWY 13L

Amdt 7 97254

41°32'N-93°40'W

DES MOINES, IOWA  
 DES MOINES INTL (DSM)

FIGURE 25.—ILS RWY 13L (DSM).



Amdt 21 96172

# ILS RWY 24R

AL-237 (FAA)

LOS ANGELES INTL (LAX)  
LOS ANGELES, CALIFORNIA

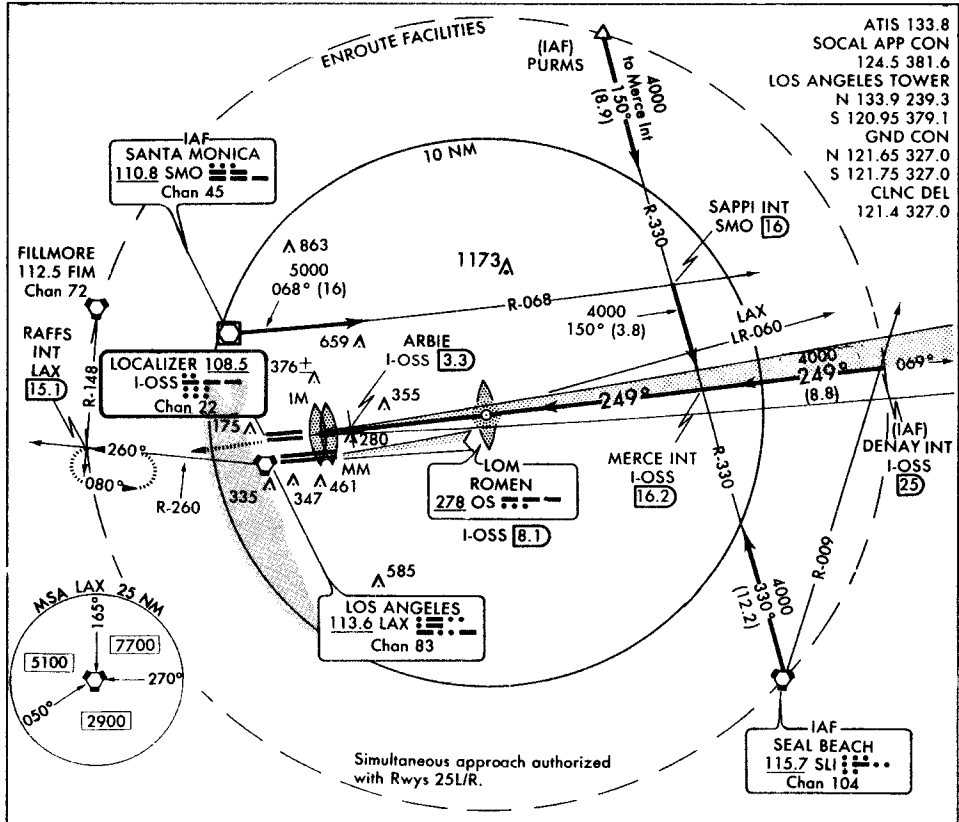

ATIS 133.8  
SOCAL APP CON 124.5 381.6  
LOS ANGELES TOWER  
N 133.9 239.3  
S 120.95 379.1  
GND CON  
N 121.65 327.0  
S 121.75 327.0  
CLNC DEL 121.4 327.0

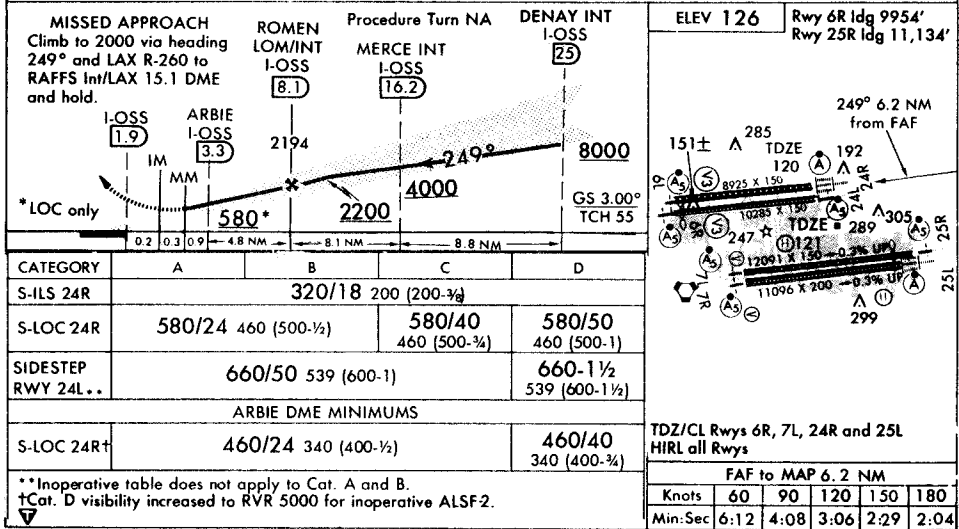

CATEGORY	A	B	C	D
S-ILS 24R	320/18 200 (200-¾)			
S-LOC 24R	580/24	460 (500-½)	580/40 460 (500-¾)	580/50 460 (500-1)
SIDESTEP RWY 24L..	660/50 539 (600-1)			660-1 ½ 539 (600-1 ½)
ARBIE DME MINIMUMS				
S-LOC 24R†	460/24 340 (400-½)		460/40 340 (400-¾)	

\*\*Inoperative table does not apply to Cat. A and B.  
†Cat. D visibility increased to RVR 5000 for inoperative ALSF2.

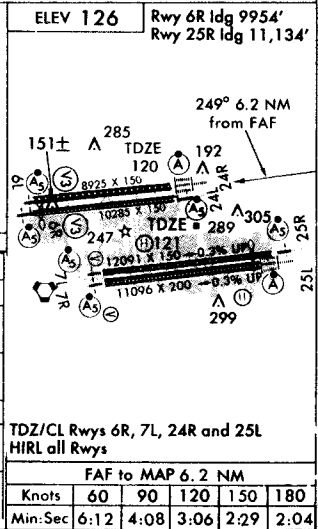

## ILS RWY 24R

Amdt 21 96172

33°57'N - 118°24'W

LOS ANGELES, CALIFORNIA  
LOS ANGELES INTL (LAX)

FIGURE 26.—ILS RWY 24R (LAX).

Amdt 1 96340

# ILS/DME RWY 35R

AL-9077 (FAA)

DENVER INTL (DEN)  
DENVER, COLORADO

ATIS 125.6 379.9  
DENVER APP CON  
119.3 307.3 (NORTH)  
120.35 381.5 (SOUTH)  
DENVER TOWER  
133.3 322.45  
GND CON  
127.5 380.3  
CLNC DEL 118.75

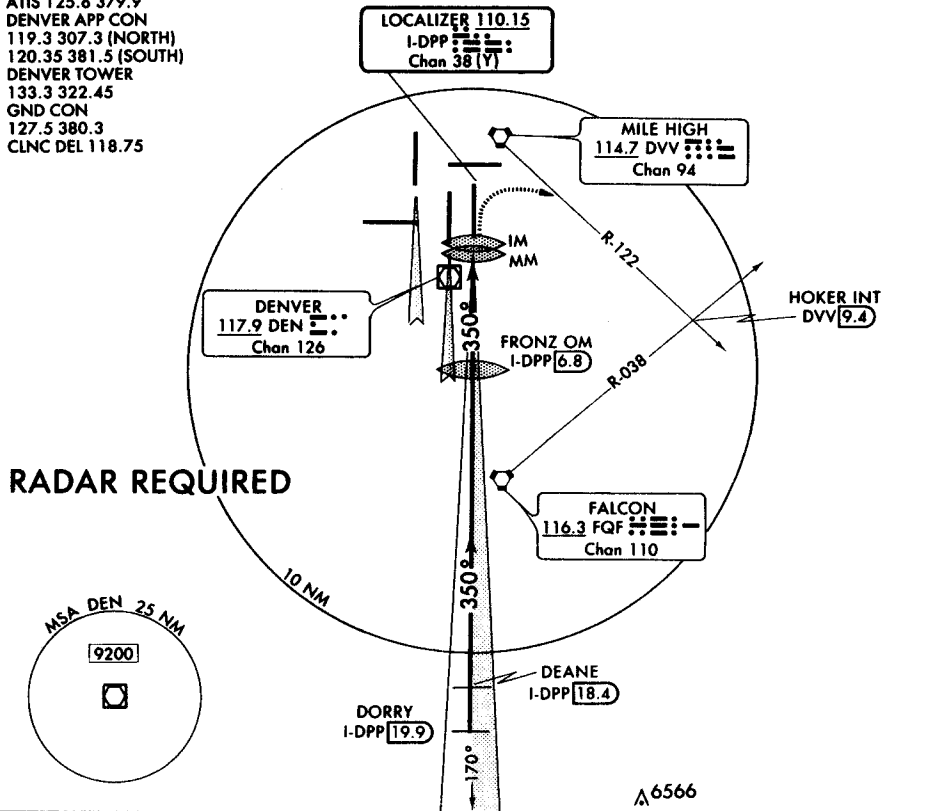

**RADAR REQUIRED**

**MISSED APPROACH**  
Climb to 5800 then climbing right turn to 8000 via heading 090° and DVV VORTAC R-122 to HOKER Int.

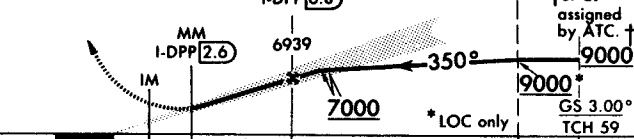

CATEGORY	A	B	C	D
S-ILS 35R	5567/18 200 (200-¾)			
S-LOC 35R	5940/24 573 (600-½)	5940/50 573 (600-1)	5940/60 573 (600-1 ½)	
CIRCLING	NA			

Simultaneous approaches authorized with Rwy 34 and Rwy 35L.  
S-LOC minima not authorized during simultaneous operations.

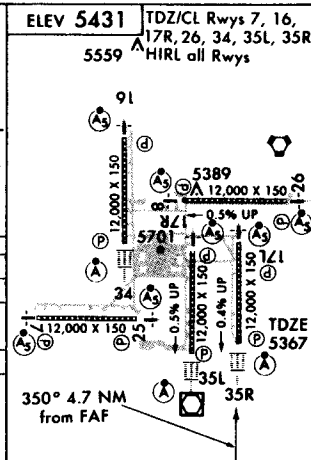

Knots	60	90	120	150	180
Min:Sec					

# ILS/DME RWY 35R

39°52'N-104°40'W

DENVER, COLORADO  
DENVER INTL (DEN)

Amdt 1 96340

FIGURE 27.—ILS/DME RWY 35R (DEN).





Orig 90151

**VOR/DME-A**

AL-6787 (FAA)

**BALDWIN MUNI (7D3)**  
BALDWIN, MICHIGAN

MINNEAPOLIS CENTER  
132.9 398.9  
CTAF 122.9

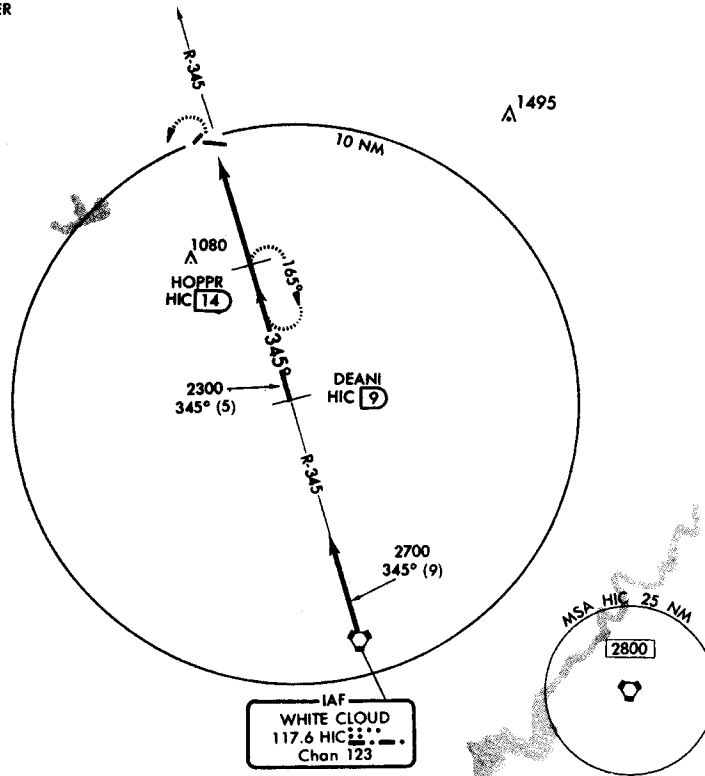

**MISSED APPROACH**  
Climbing left turn to 2600 via  
HIC R-345 to Hopper 14 DME  
and hold.

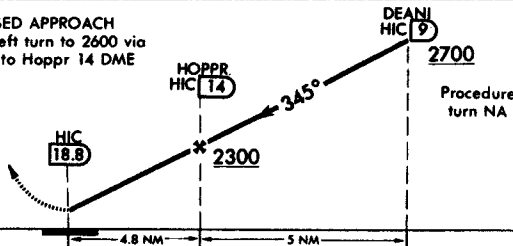

ELEV 828

Procedure  
turn NA

CATEGORY	A	B	C	D
CIRCLING	1540-1 712 (800-1)		1540-2 712 (800-2)	NA

Use Muskegon altimeter setting.  
Procedure not authorized at night.

△ NA

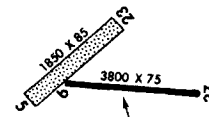

345° 4.8 NM  
from FAF

Knots	60	90	120	150	180
Min:Sec					

**VOR/DME-A**

43°53'N-85°50'W

BALDWIN, MICHIGAN  
**BALDWIN MUNI (7D3)**

FIGURE 30.—VOR/DME-A (7D3).

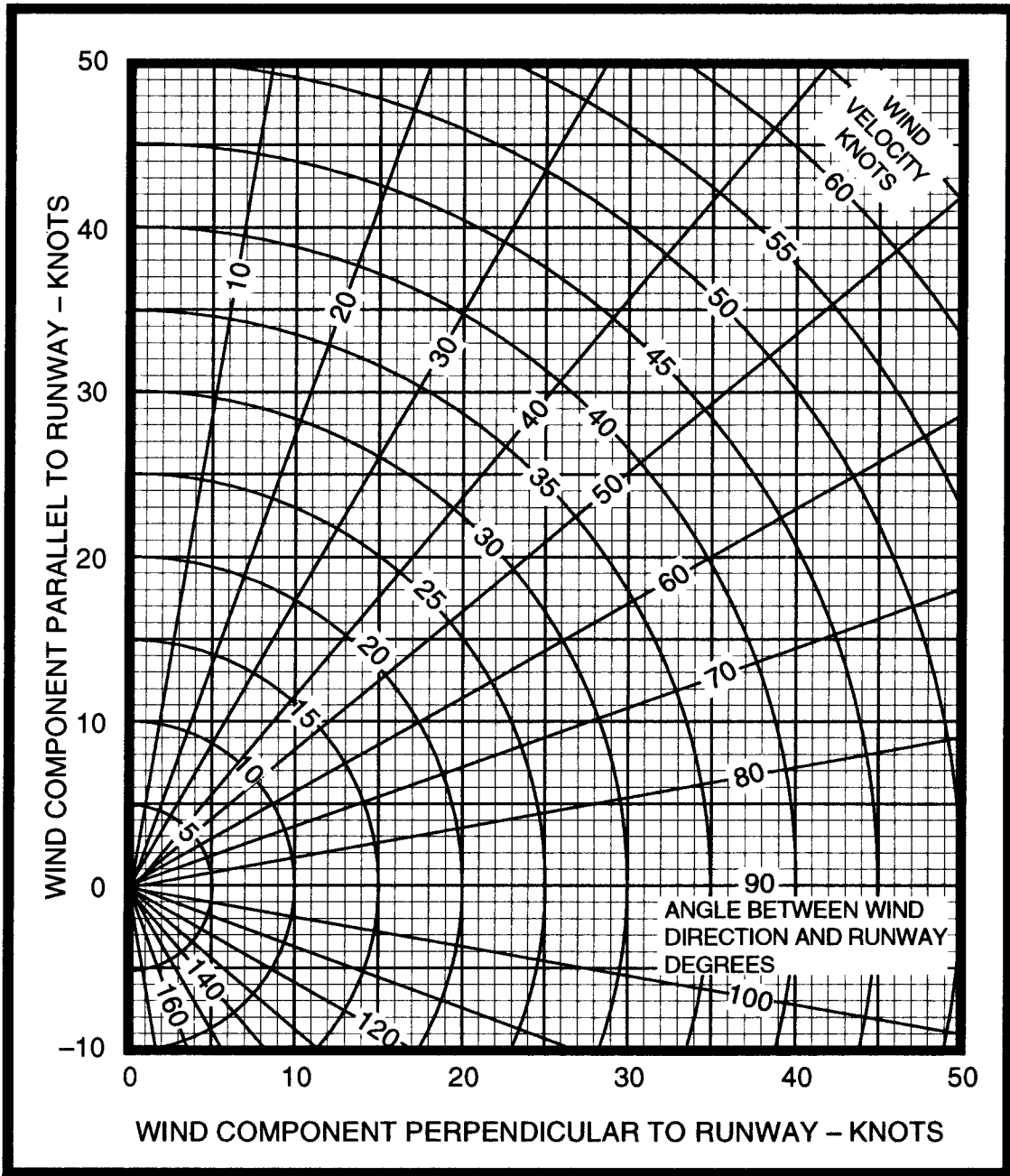

FIGURE 31.—Wind Component Chart.

**ASSOCIATED CONDITIONS:**

POWER TAKEOFF POWER  
 SET BEFORE  
 BRAKE RELEASE  
 FLAPS 20\*  
 RUNWAY PAVED, LEVEL,  
 DRY SURFACE  
 TAKEOFF SPEED IAS AS TABULATED

NOTE: GROUND ROLL IS APPROX. 73%  
 OF TOTAL TAKEOFF DISTANCE  
 OVER A 50 FT OBSTACLE

**EXAMPLE:**

OAT 75 °F  
 PRESSURE ALTITUDE 4000 FT  
 TAKEOFF WEIGHT 3100 LB  
 HEADWIND 20 KNOTS

TOTAL TAKEOFF DISTANCE  
 OVER A 50 FT OBSTACLE 1350 FT  
 GROUND ROLL (73% OF 1350) 986 FT  
 IAS TAKEOFF SPEED  
 LIFT-OFF AT 50 FT 74 MPH

WEIGHT POUNDS	IAS TAKEOFF SPEED (ASSUMES ZERO INSTR. ERROR)			
	LIFT-OFF		50 FEET	
	MPH	KNOTS	MPH	KNOTS
3400	77	67	77	67
3200	75	65	75	65
3000	72	63	72	63
2800	69	60	69	60
2600	66	57	66	57
2400	63	55	63	55

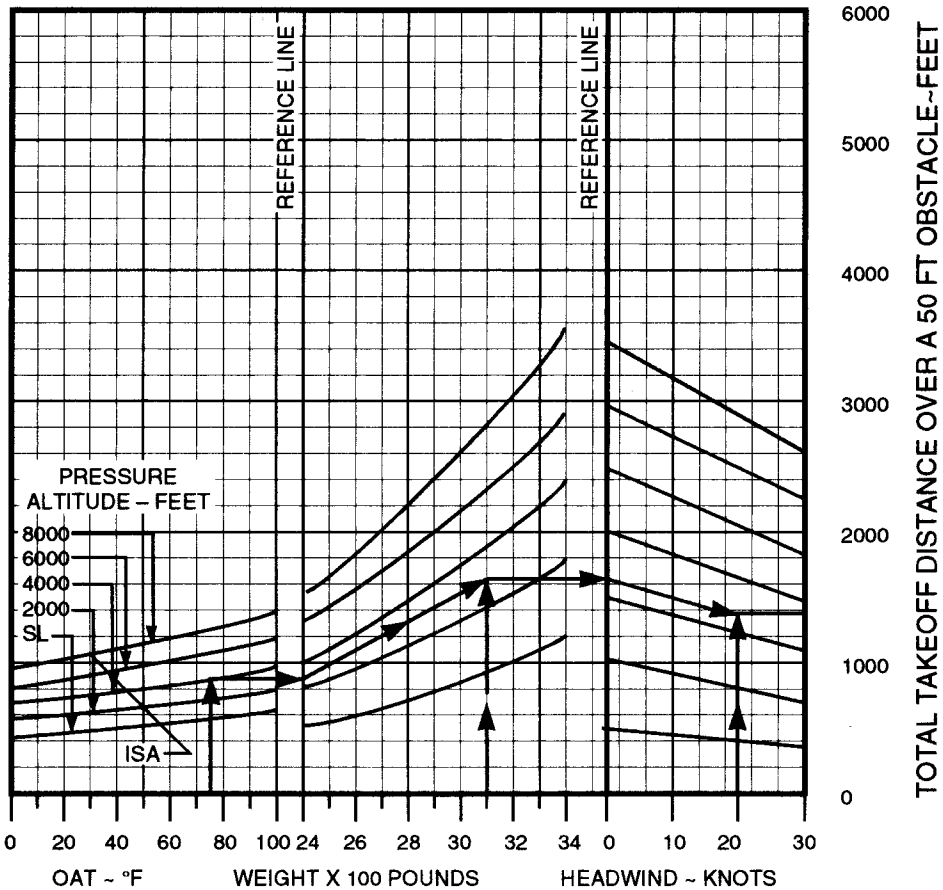

FIGURE 32.—Obstacle Take-off Chart.

CONDITIONS:  
 Flaps Up  
 Gear Up  
 2600 RPM  
 Cowl Flaps Open

PRESS ALT	MP	PPH
S.L. TO 17,000	35	162
18,000	34	156
20,000	32	144
22,000	30	132
24,000	28	120

WEIGHT LBS	PRESS ALT FT	CLIMB SPEED KIAS	RATE OF CLIMB - FPM			
			-20 °C	0 °C	20 °C	40 °C
4000	S.L.	100	1170	1035	895	755
	4000	100	1080	940	800	655
	8000	100	980	840	695	555
	12,000	100	870	730	590	---
	16,000	100	740	605	470	---
	20,000	99	485	355	---	---
	24,000	97	190	70	---	---
3700	S.L.	99	1310	1165	1020	875
	4000	99	1215	1070	925	775
	8000	99	1115	965	815	670
	12,000	99	1000	855	710	---
	16,000	99	865	730	590	---
	20,000	97	600	470	---	---
	24,000	95	295	170	---	---
3400	S.L.	97	1465	1320	1165	1015
	4000	97	1370	1220	1065	910
	8000	97	1265	1110	955	795
	12,000	97	1150	995	845	---
	16,000	97	1010	865	725	---
	20,000	96	730	595	---	---
	24,000	94	405	275	---	---

FIGURE 33.—Maximum Rate-of-Climb Chart.



## PRESSURE ALTITUDE 6,000 FEET

CONDITIONS:  
 Recommended Lean Mixture  
 3800 Pounds  
 Cowl Flaps Closed

		20 °C BELOW STANDARD TEMP -17 °C			STANDARD TEMPERATURE 3 °C			20 °C ABOVE STANDARD TEMP 23 °C		
RPM	MP	% BHP	KTAS	PPH	% BHP	KTAS	PPH	% BHP	KTAS	PPH
2550	24	---	---	---	78	173	97	75	174	94
	23	76	167	96	74	169	92	71	171	89
	22	72	164	90	69	166	87	67	167	84
	21	68	160	85	65	162	82	63	163	80
2500	24	78	169	98	75	171	95	73	172	91
	23	74	166	93	71	167	90	69	169	87
	22	70	162	88	67	164	85	65	165	82
	21	66	158	83	63	160	80	61	160	77
2400	24	73	165	91	70	166	88	68	167	85
	23	69	161	87	67	163	84	64	164	81
	22	65	158	82	63	159	79	61	160	77
	21	61	154	77	59	155	75	57	155	73
2300	24	68	161	86	66	162	83	64	163	80
	23	65	158	82	62	159	79	60	159	76
	22	61	154	77	59	155	75	57	155	72
	21	57	150	73	55	150	71	53	150	68
2200	24	63	156	80	61	157	77	59	158	75
	23	60	152	76	58	153	73	56	154	71
	22	57	149	72	54	149	70	53	149	67
	21	53	144	68	51	144	66	49	143	64
	20	50	139	64	48	138	62	46	137	60
	19	46	133	60	44	132	58	43	131	57

FIGURE 34.—Cruise Performance Chart.

**ASSOCIATED CONDITIONS:**

POWER AS REQUIRED TO MAINTAIN 800 FT/MIN DESCENT ON APPROACH  
 FLAPS DOWN  
 RUNWAY PAVED, LEVEL, DRY SURFACE

APPROACH SPEED IAS A TABULATED

NOTE: GROUND ROLL IS APPROX. 53% OF TOTAL LANDING DISTANCE OVER A 50 FT OBSTACLE.

**EXAMPLE:**

OAT 75 °F  
 PRESSURE ALTITUDE 4000 FT  
 LANDING WEIGHT 3200 LB  
 HEADWIND 10 KNOTS  
 TOTAL LANDING DISTANCE OVER A 50 FT OBSTACLE 1475 FT  
 GROUND ROLL (53% OF 1475) 782 FT  
 IAS APPROACH SPEED 87 MPH IAS

WEIGHT POUNDS	IAS APPROACH SPEED (ASSUMES ZERO INSTR. ERROR)	
	MPH	KNOTS
3400	90	78
3200	87	76
3000	84	73
2800	81	70
2600	78	68
2400	75	65

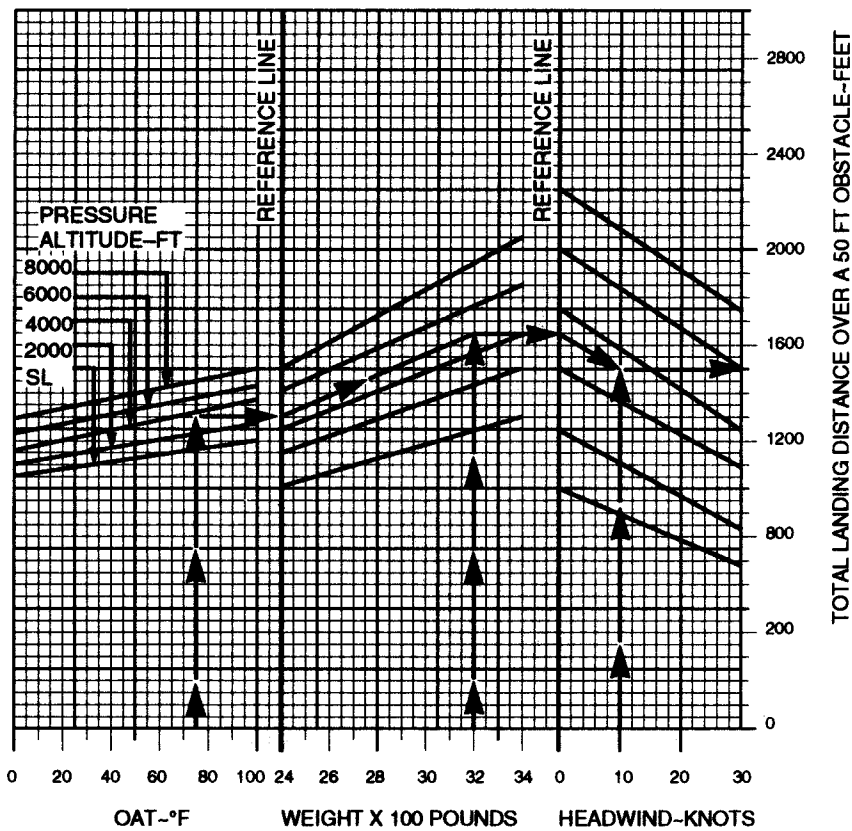

**FIGURE 35.—Normal Landing Chart.**

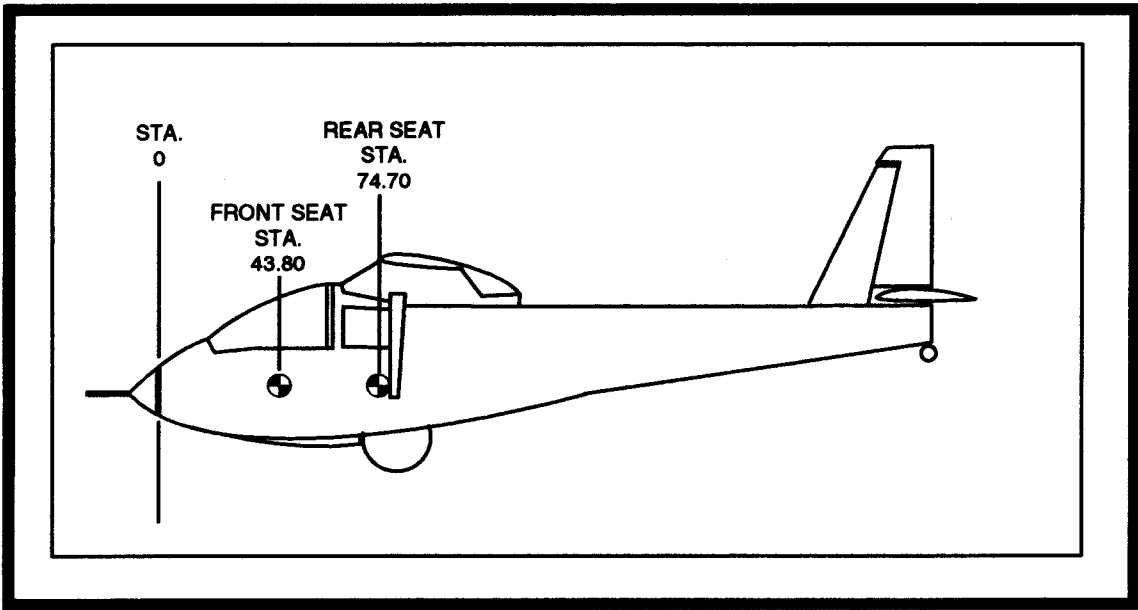

FIGURE 36.—Stations Diagram.

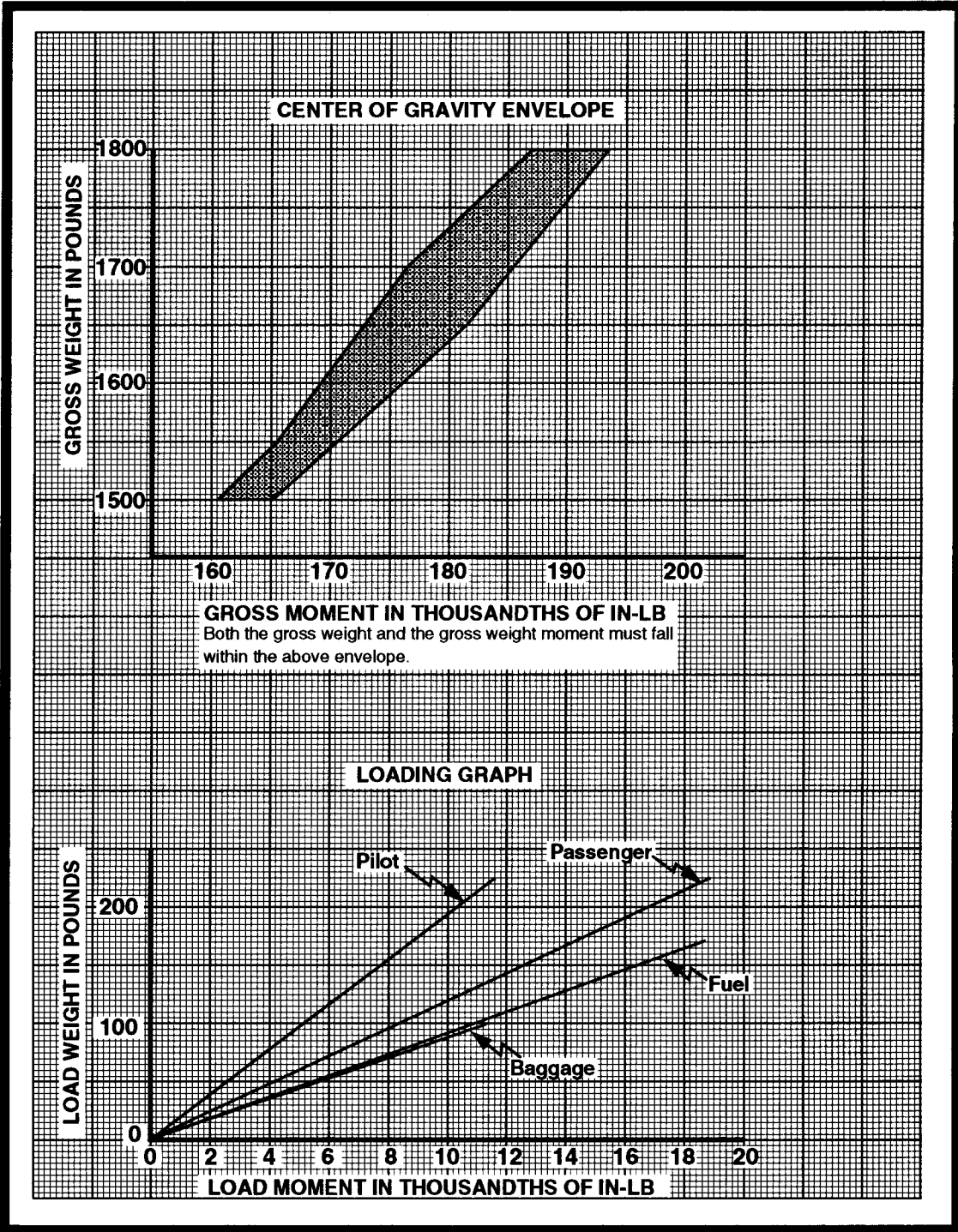

FIGURE 37.—Center-of-Gravity Envelope and Loading Graph.

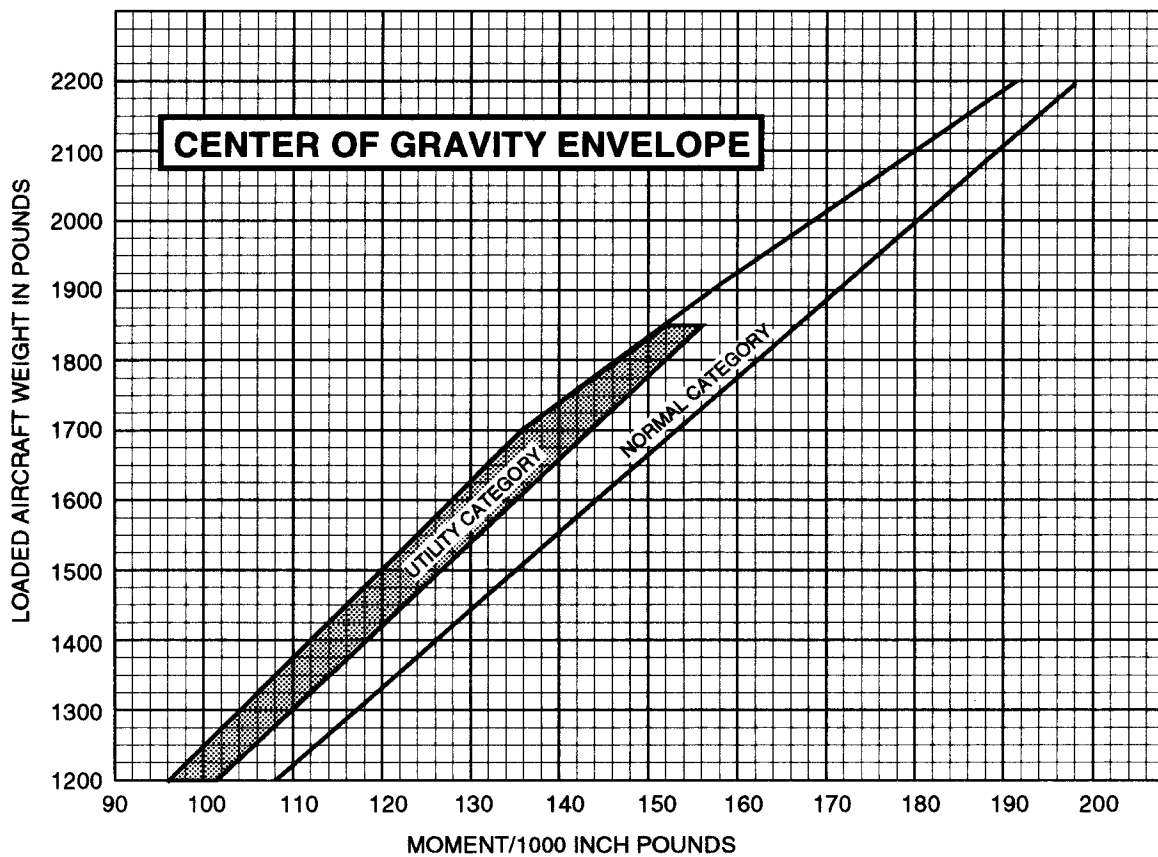
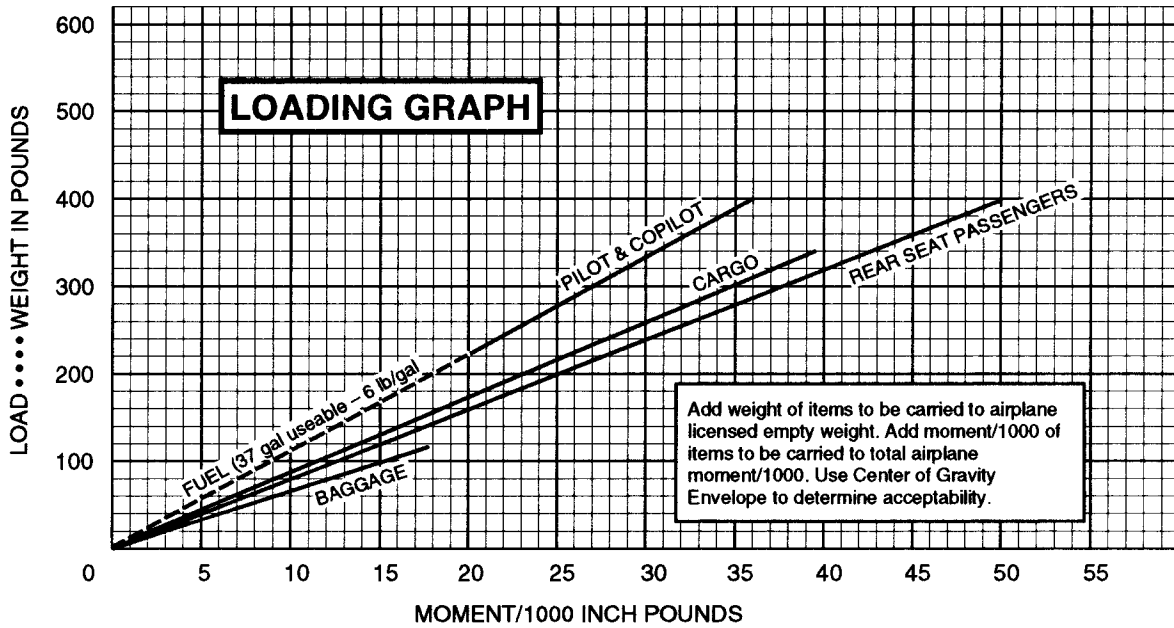

FIGURE 38.—Loading Graph and Center-of-Gravity Envelope.

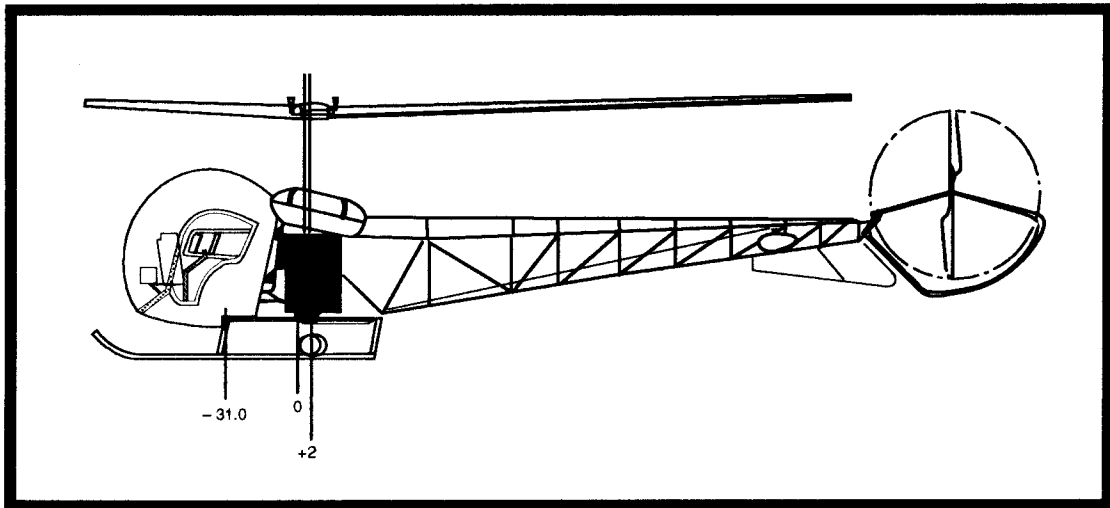

FIGURE 39.—Stations Diagram.

The following CG locations may be used when determining the helicopter CG position.

Item	Long CG	Lat CG
Pilot & Baggage under R seat	79.0	+10.7
Passenger & Baggage under L seat	79.0	-9.3
Main Fuel	108.6	-11.0
Aux Fuel (optional)	103.8	+11.2

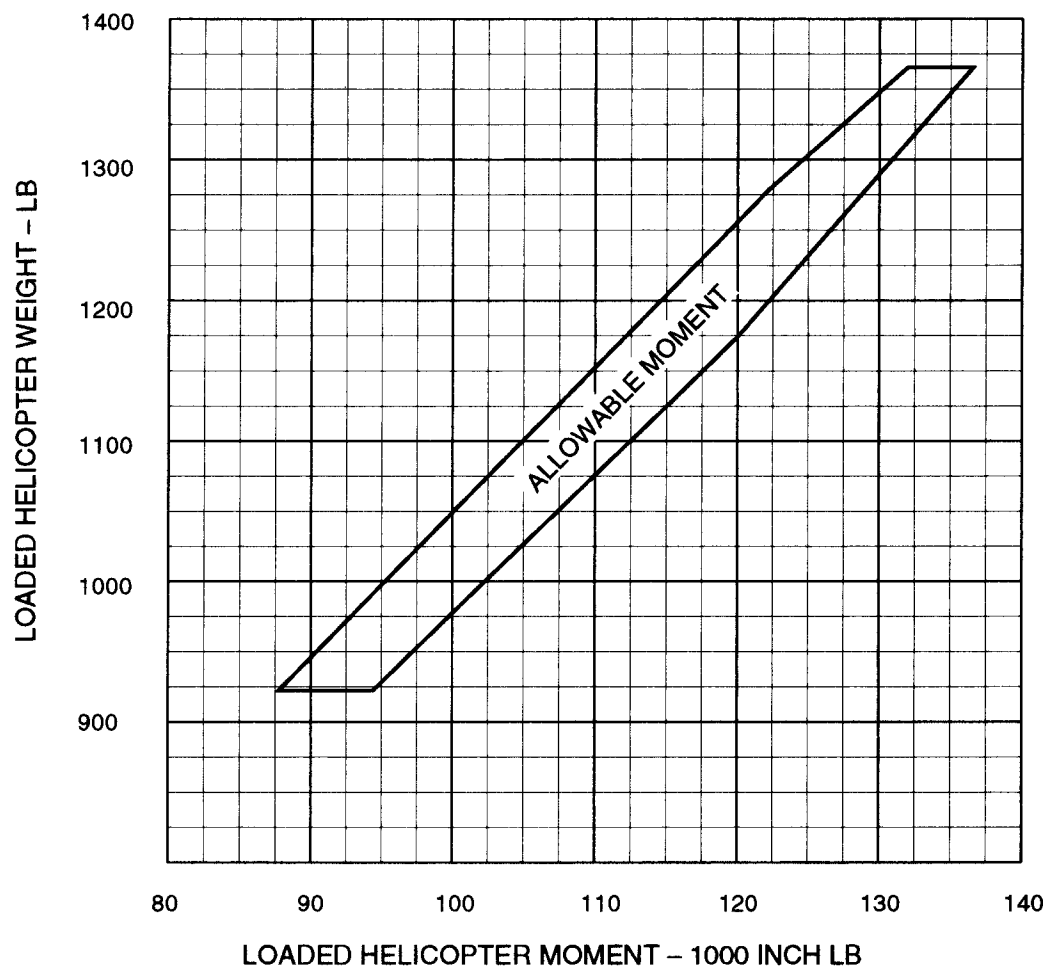
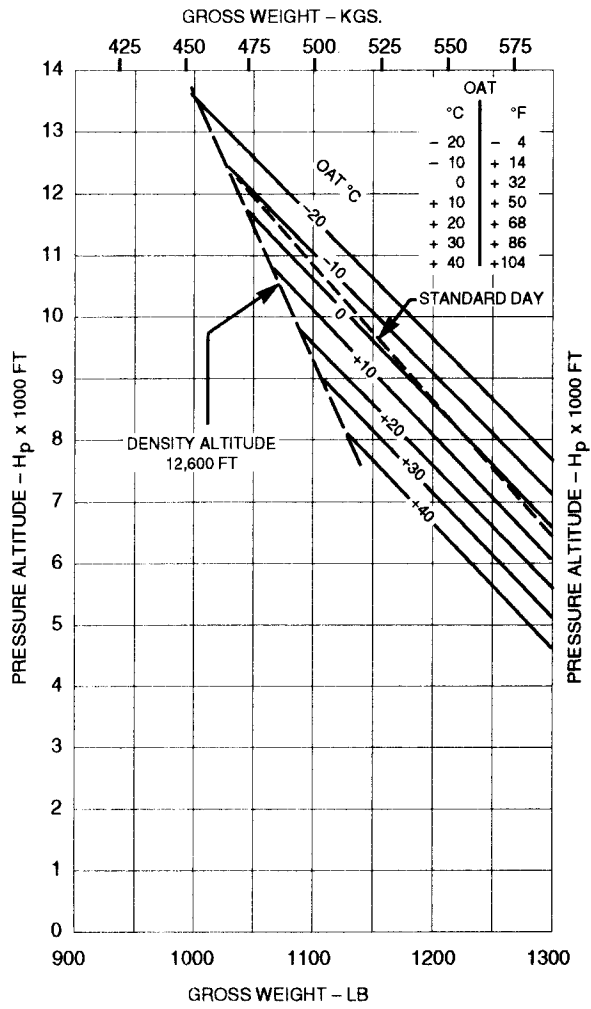

FIGURE 40.—Weight and Balance Chart.

IN GROUND EFFECT AT 2 FOOT SKID CLEARANCE  
FULL THROTTLE AND 104% RPM



OUT OF GROUND EFFECT  
FULL THROTTLE (OR LIMIT MANIFOLD PRESSURE) AND 104% RPM

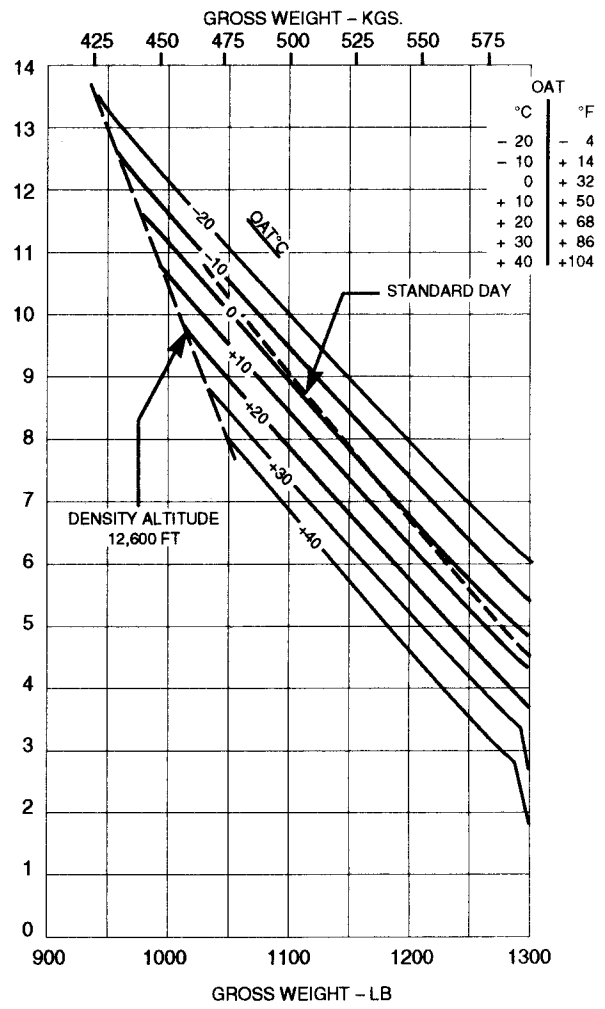

FIGURE 41.—Hover Ceiling vs. Gross Weight.



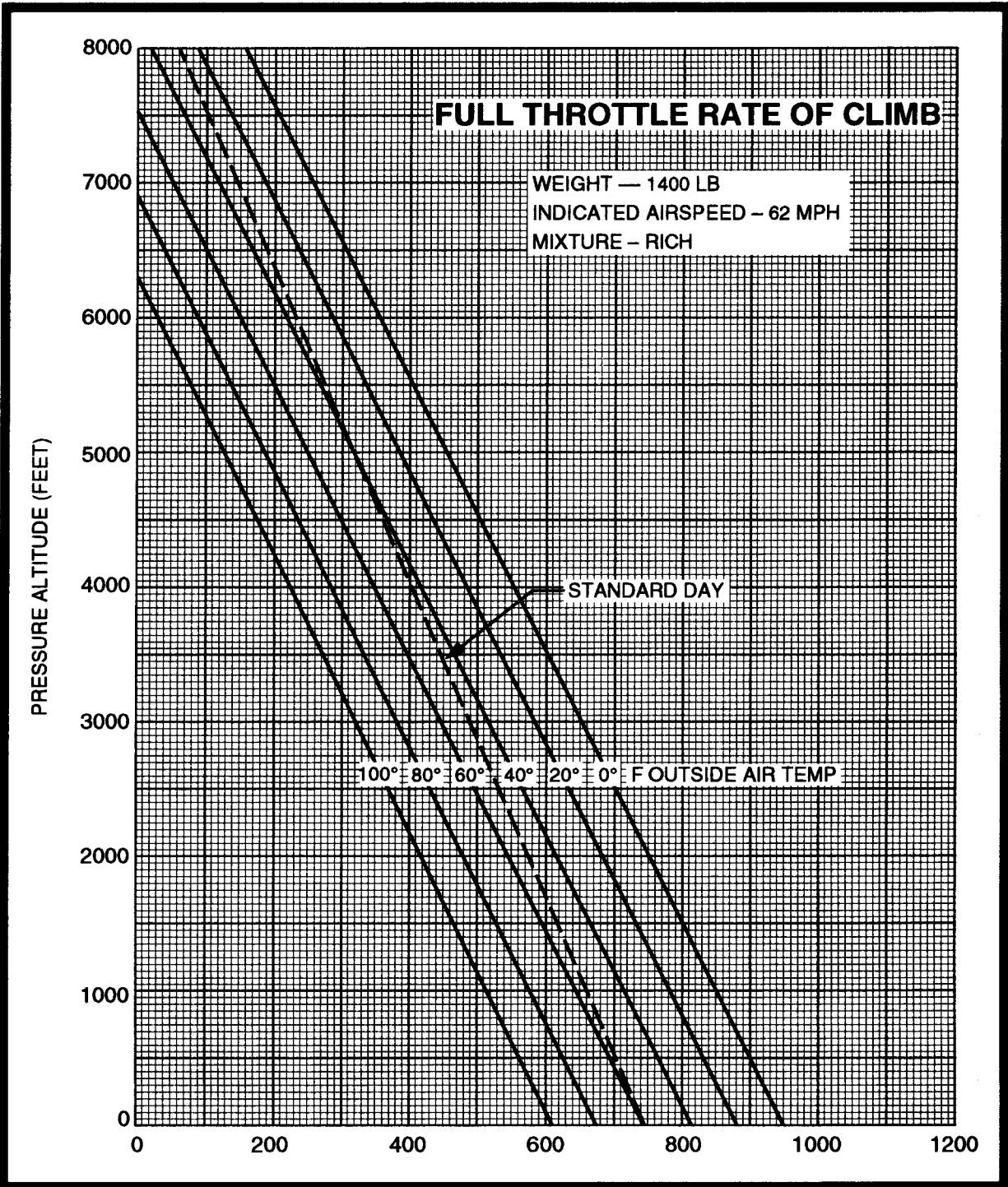

FIGURE 42.—Rate of Climb (Ft/Min).

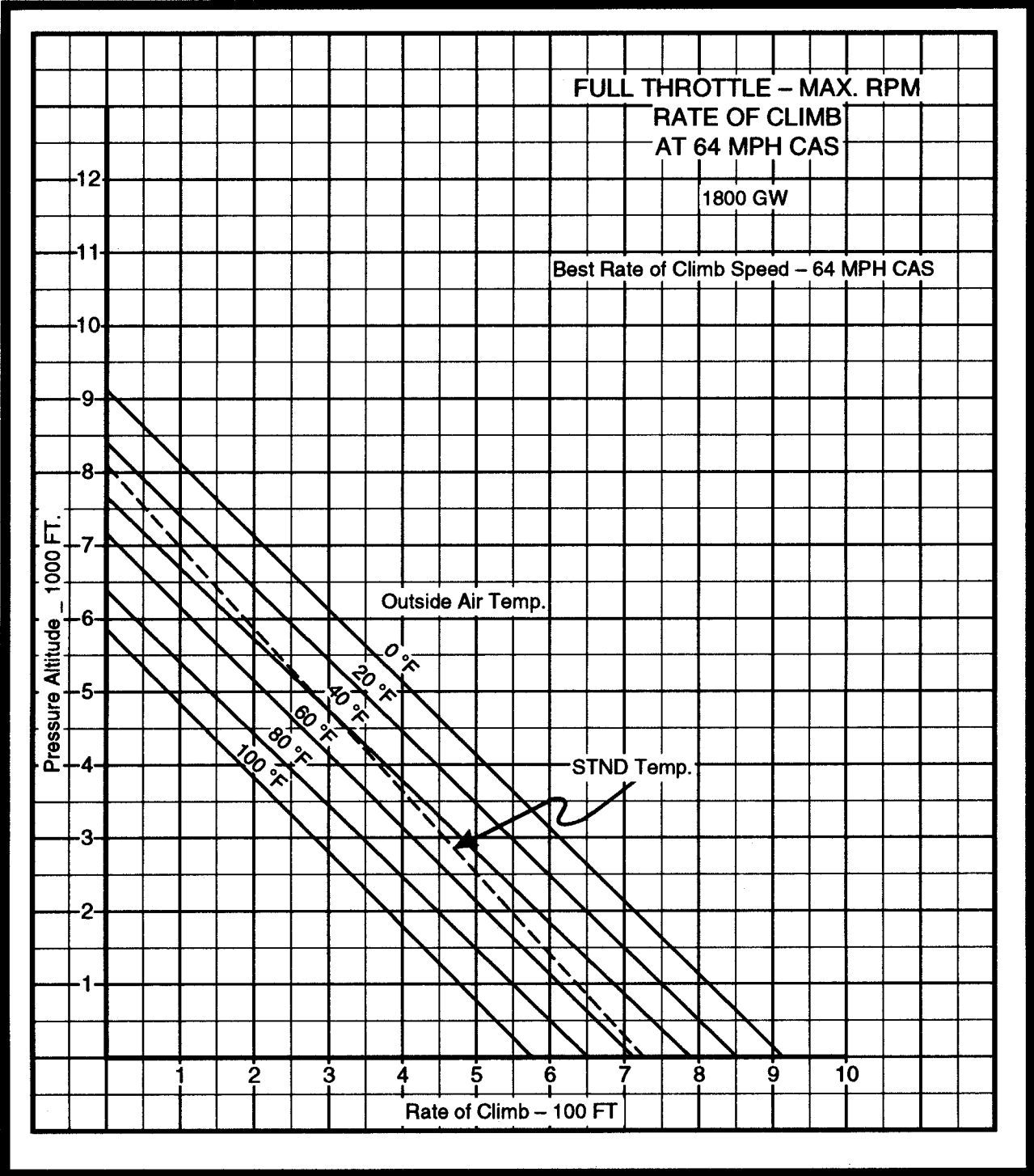

FIGURE 43.—Best Rate-of-Climb Speed.

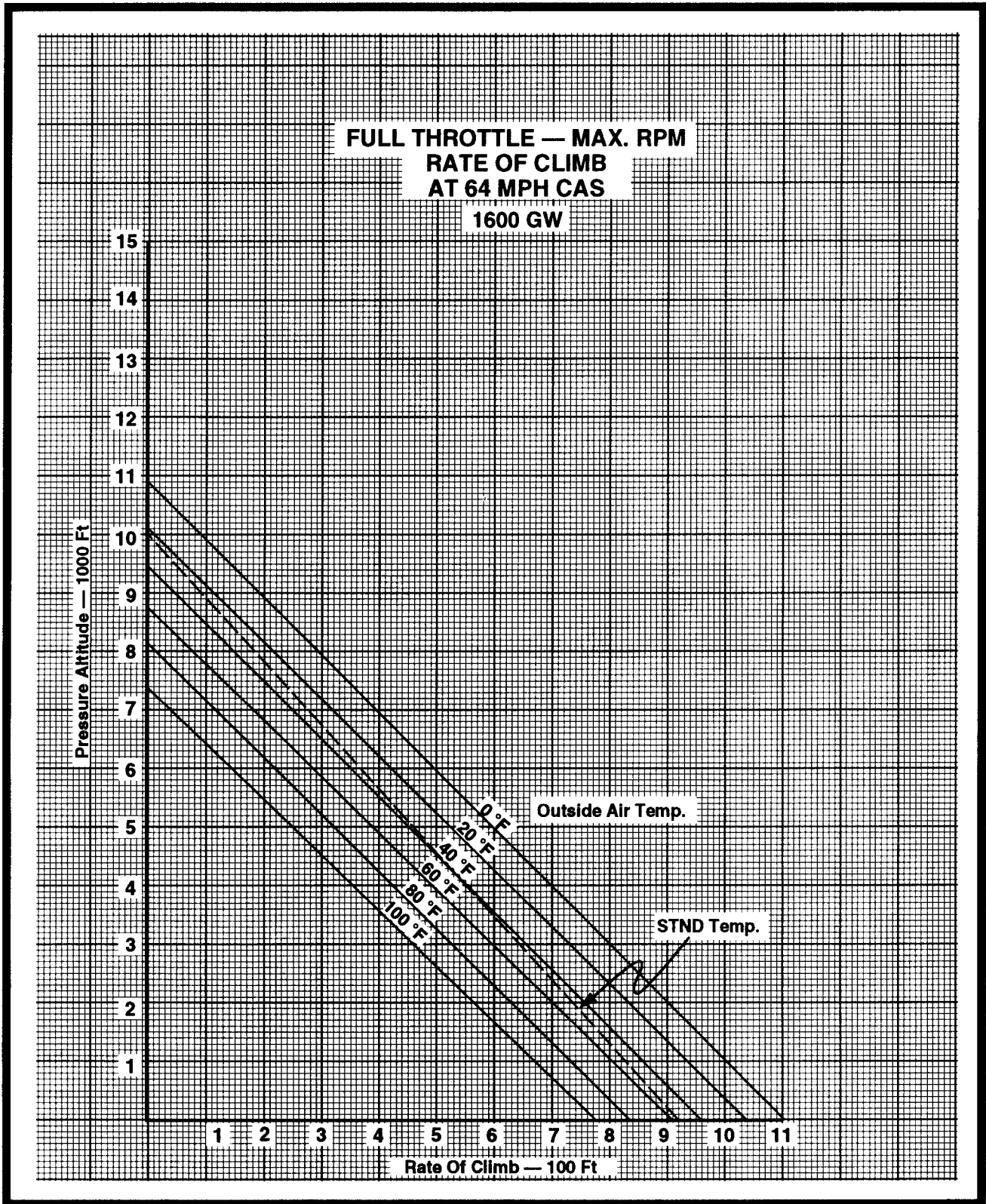

FIGURE 44.—Rate of Climb.

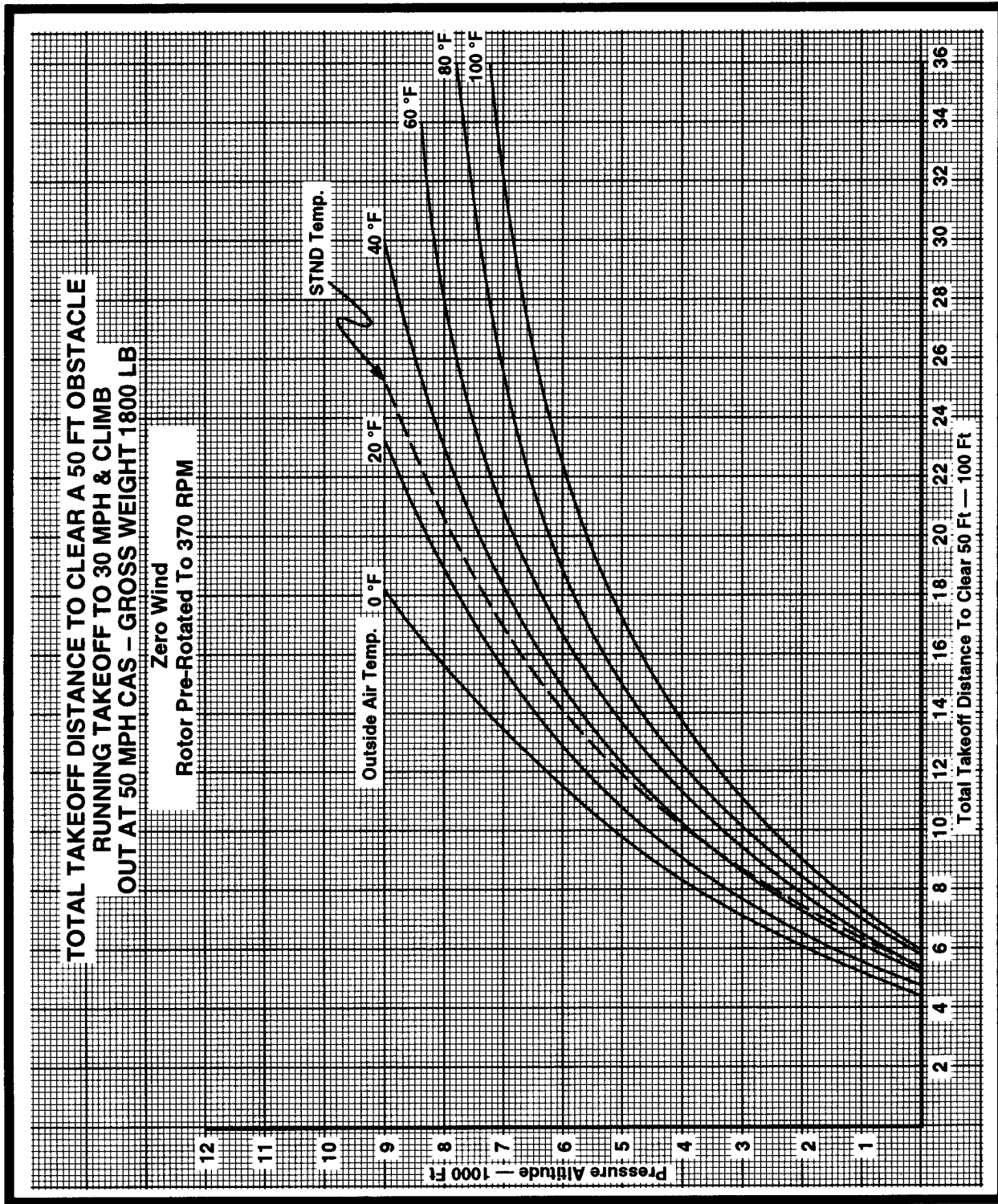

FIGURE 45.—Running Takeoff.

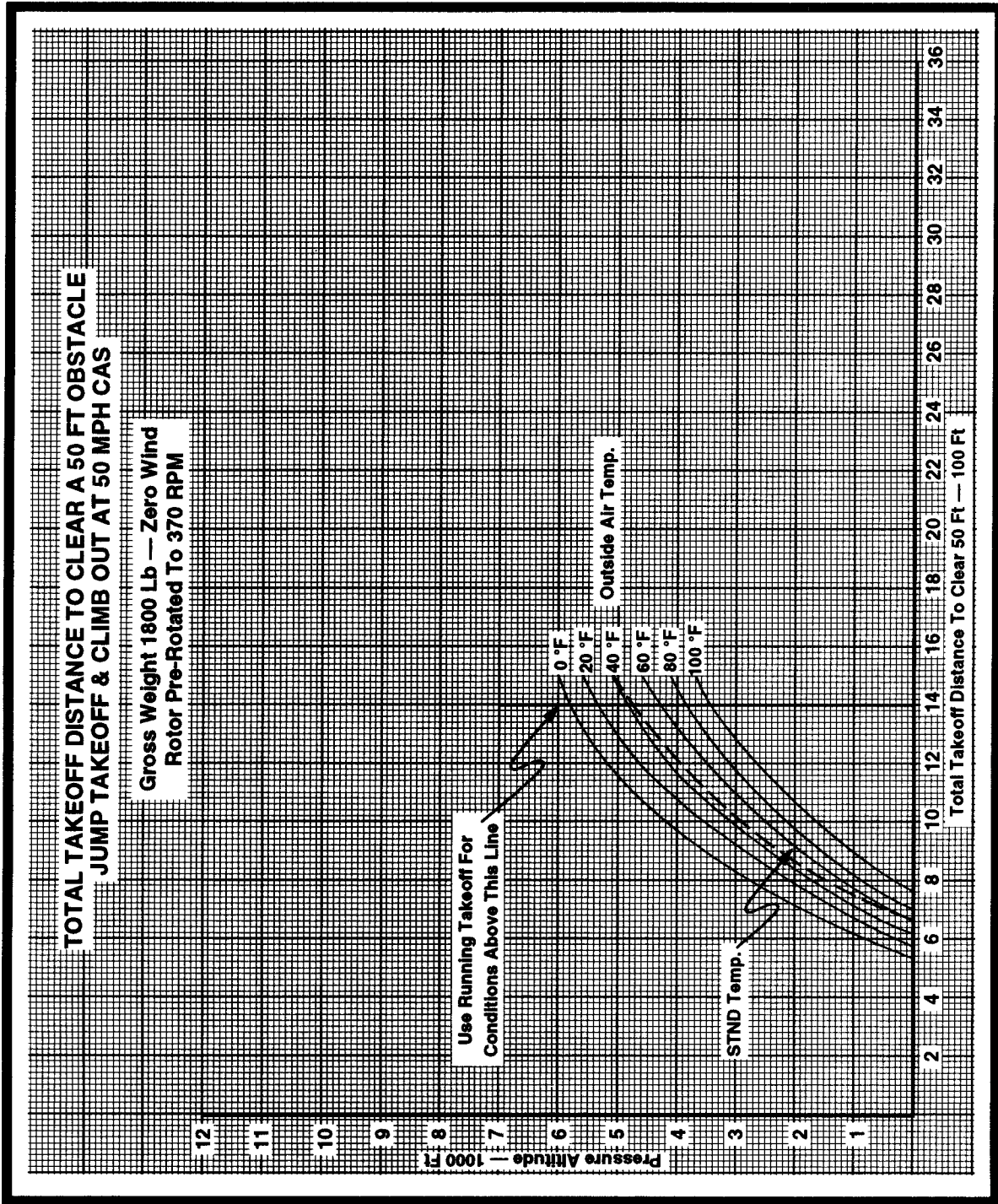

FIGURE 46.—Jump Takeoff.

**THIS PAGE INTENTIONALLY LEFT BLANK**

DESIGN DATA

Wing Span	51'	Empty Weight	600 lb
Length	25' 9"	Gross Weight	1,040 lb
Height	9' 3-1/2"	Wing Area	219.5 sq ft
Aspect Ratio	11.85	Wing Loading	4.74 psf

PERFORMANCE

Max. Speed	98 MPH	Stall (Dual)	35 MPH
Airplane Tow	98 MPH	L/D MPH Solo	22.25 to 1 at 45
Auto Winch	69 MPH	L/D MPH Dual	22.25 to 1 at 52
Dive brake			
Extend. Max.	98 MPH	Sink Speed Solo	2.6 fps at 38
Stall (solo)	31 MPH	Sink Speed Dual	3.1 fps at 42

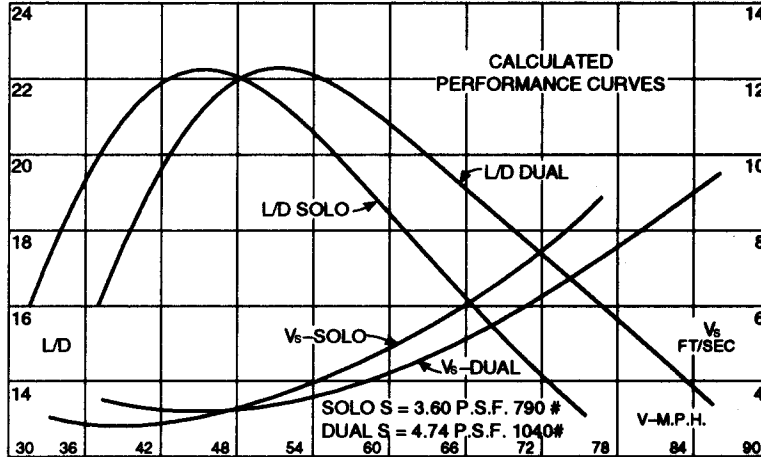

FIGURE 48.—Performance Curves Chart.

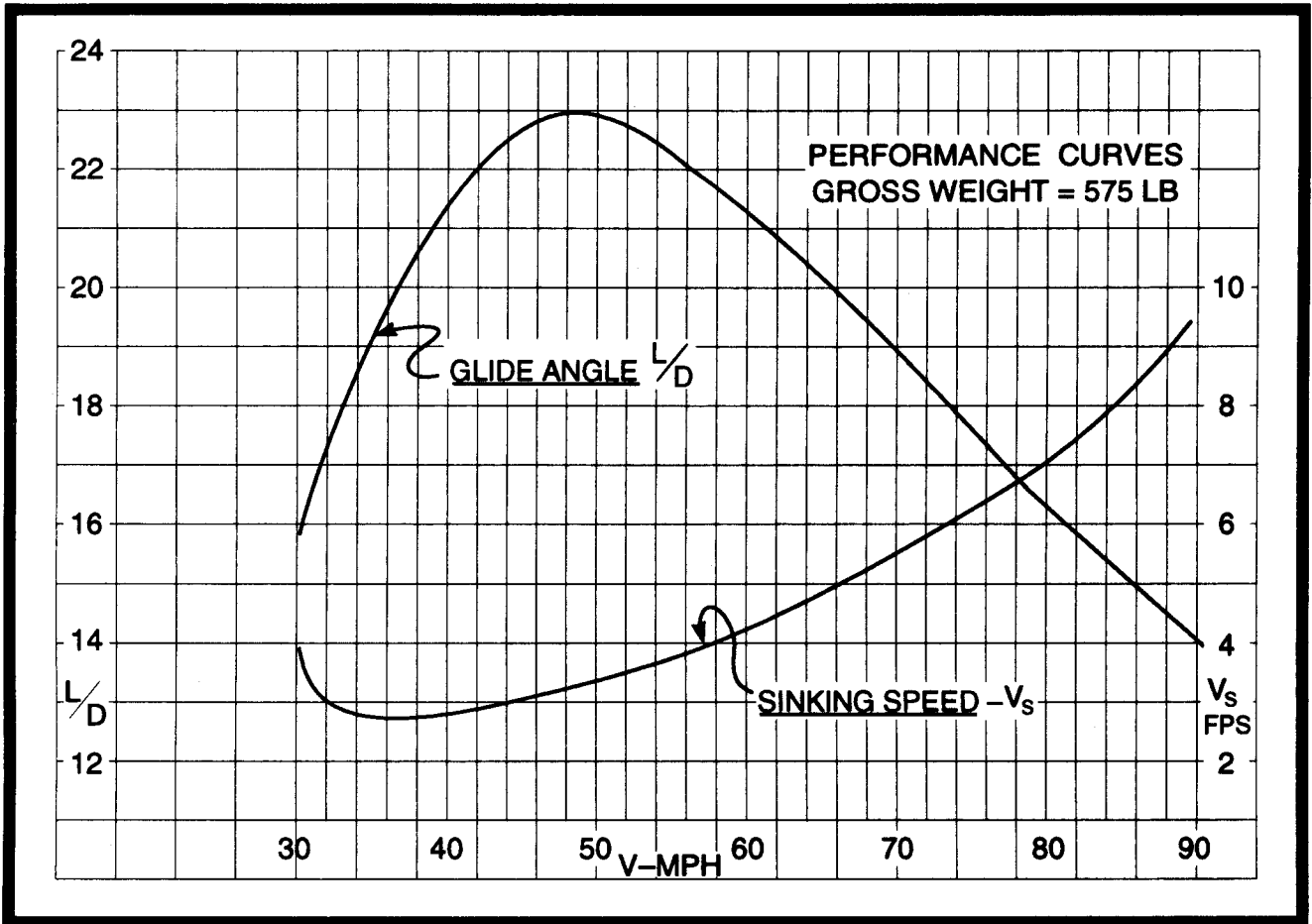

FIGURE 49.—Performance Curves Chart.



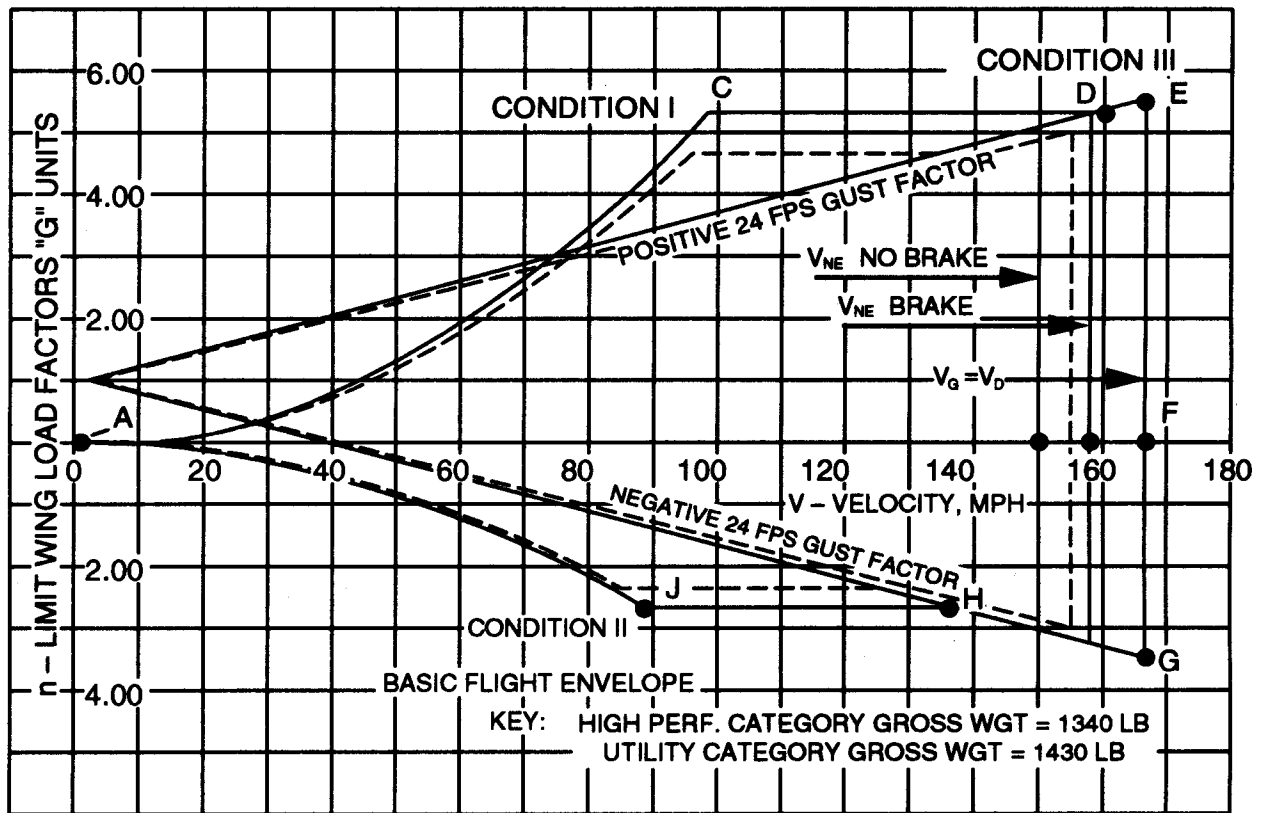

FIGURE 50.—Flight Envelope.

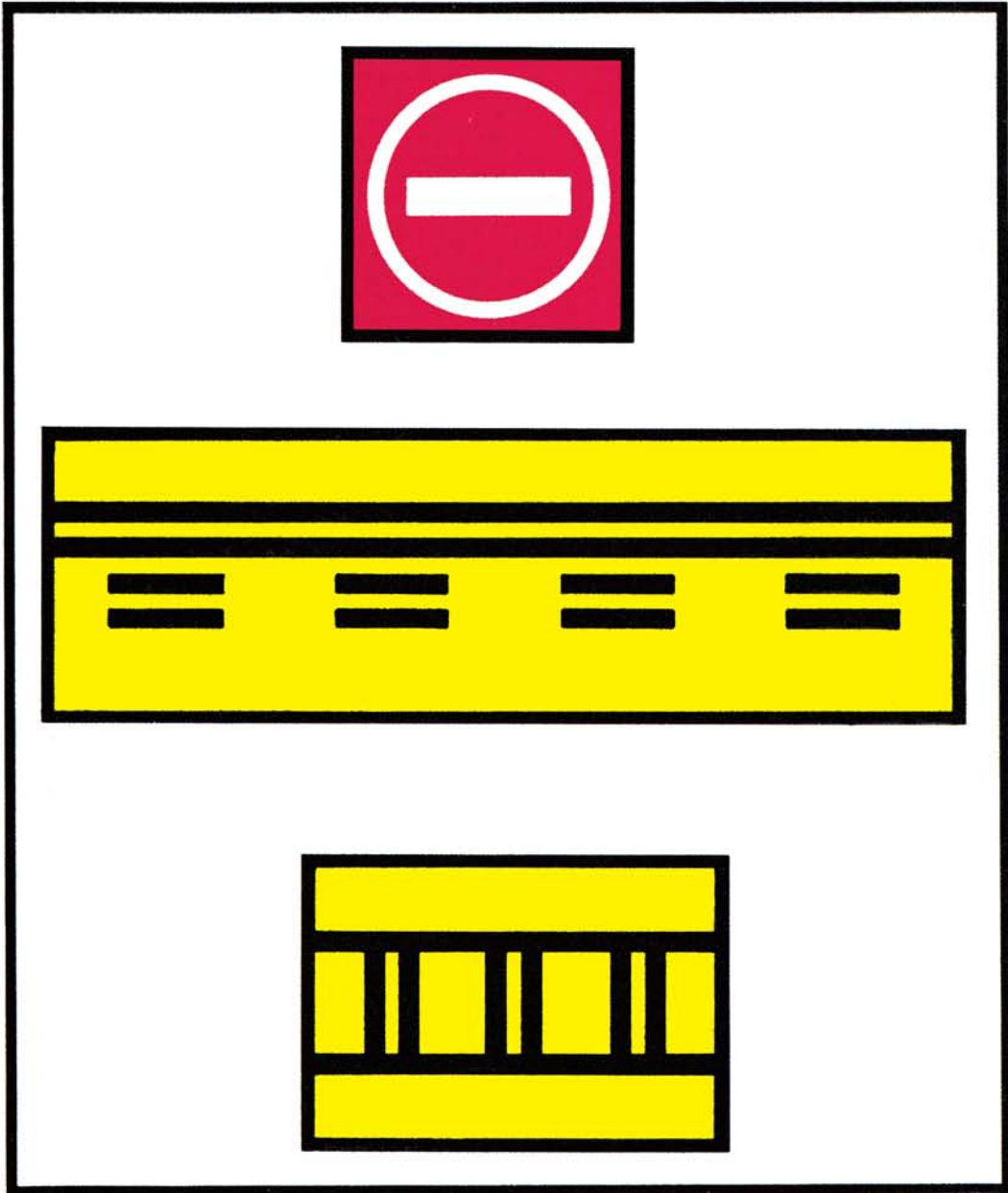

FIGURE 51.—Airport Signs.





FIGURE 52.—Sectional Chart Excerpt.



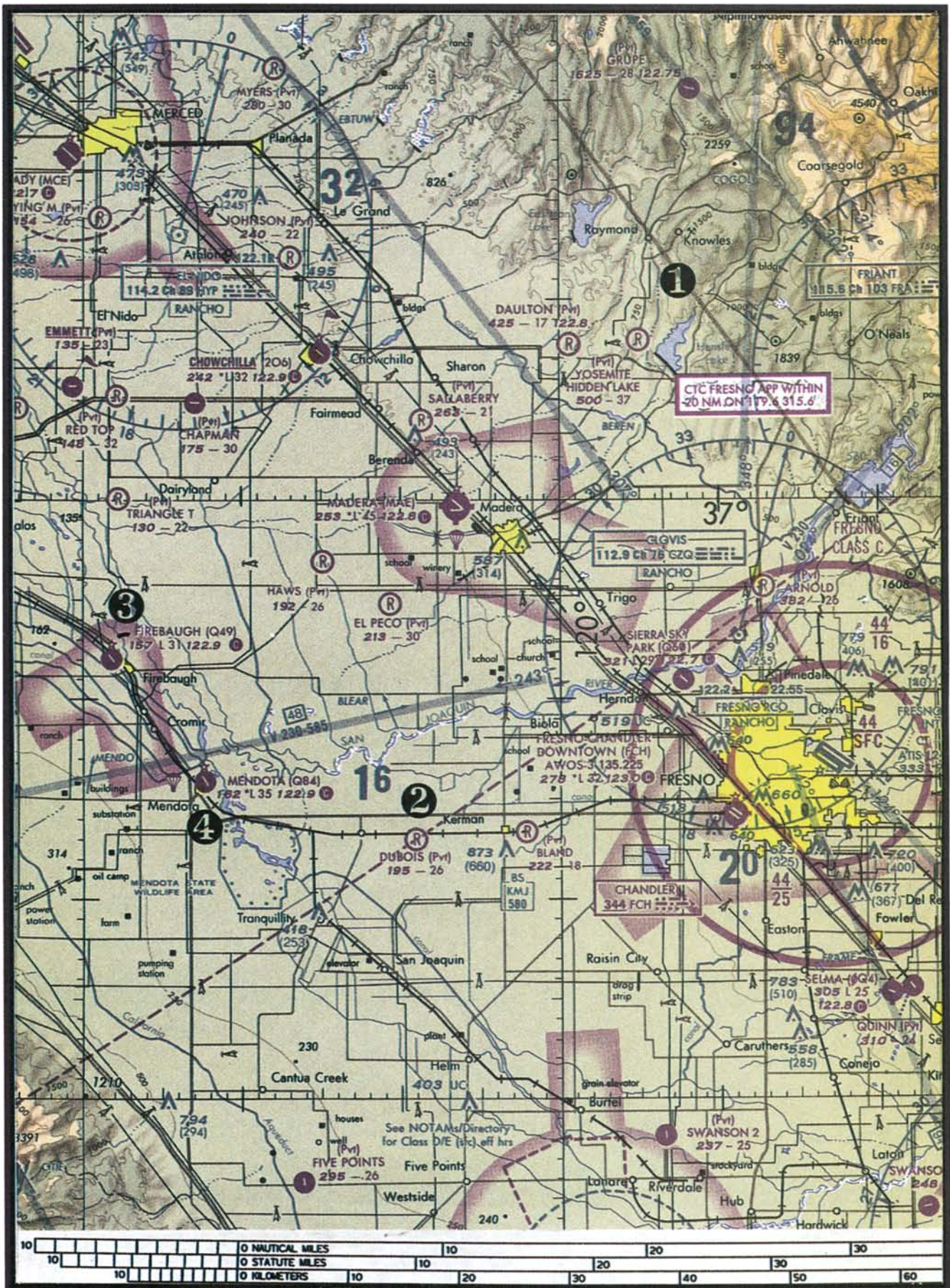

FIGURE 53.—Sectional Chart Excerpt.



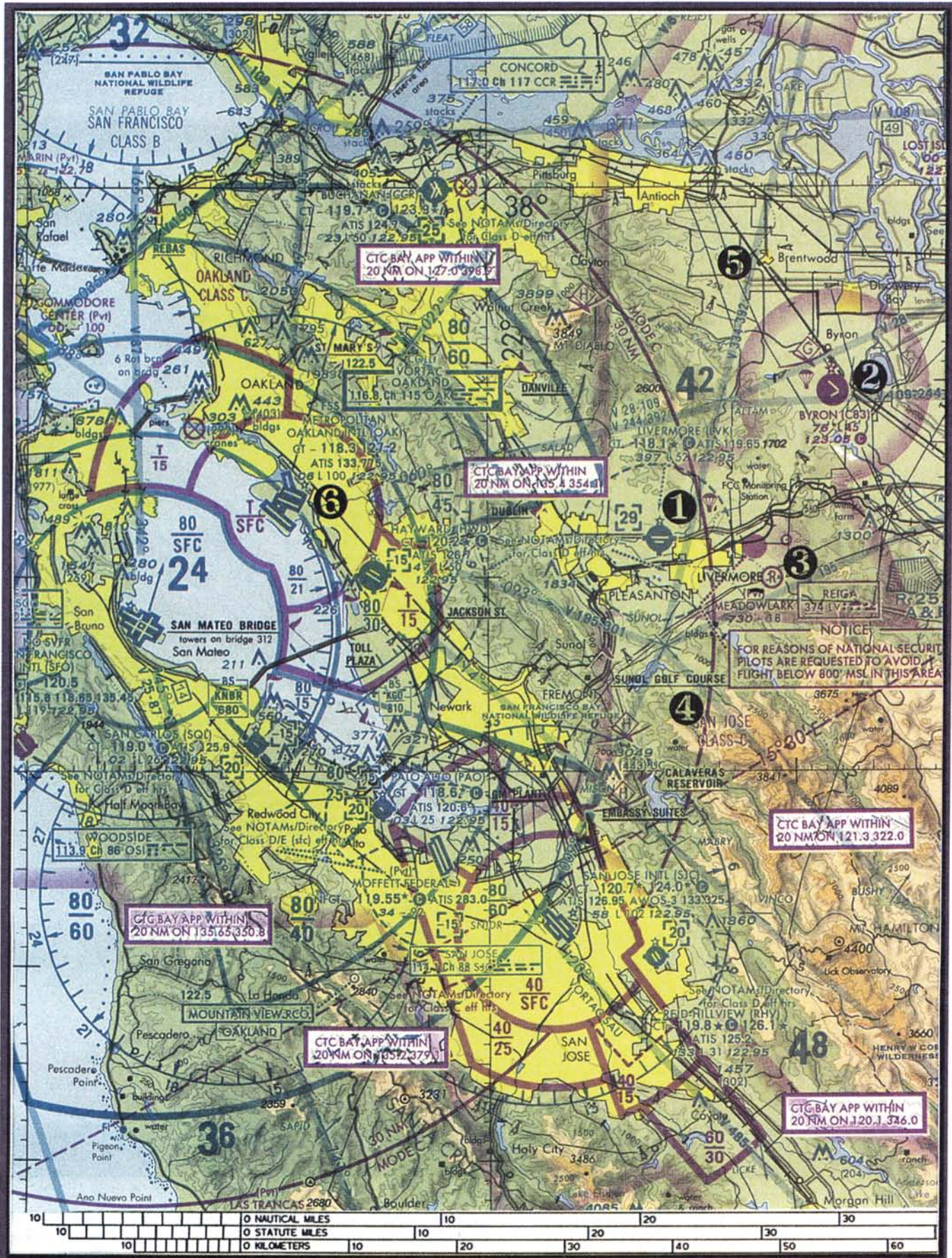

FIGURE 54.—Sectional Chart Excerpt.



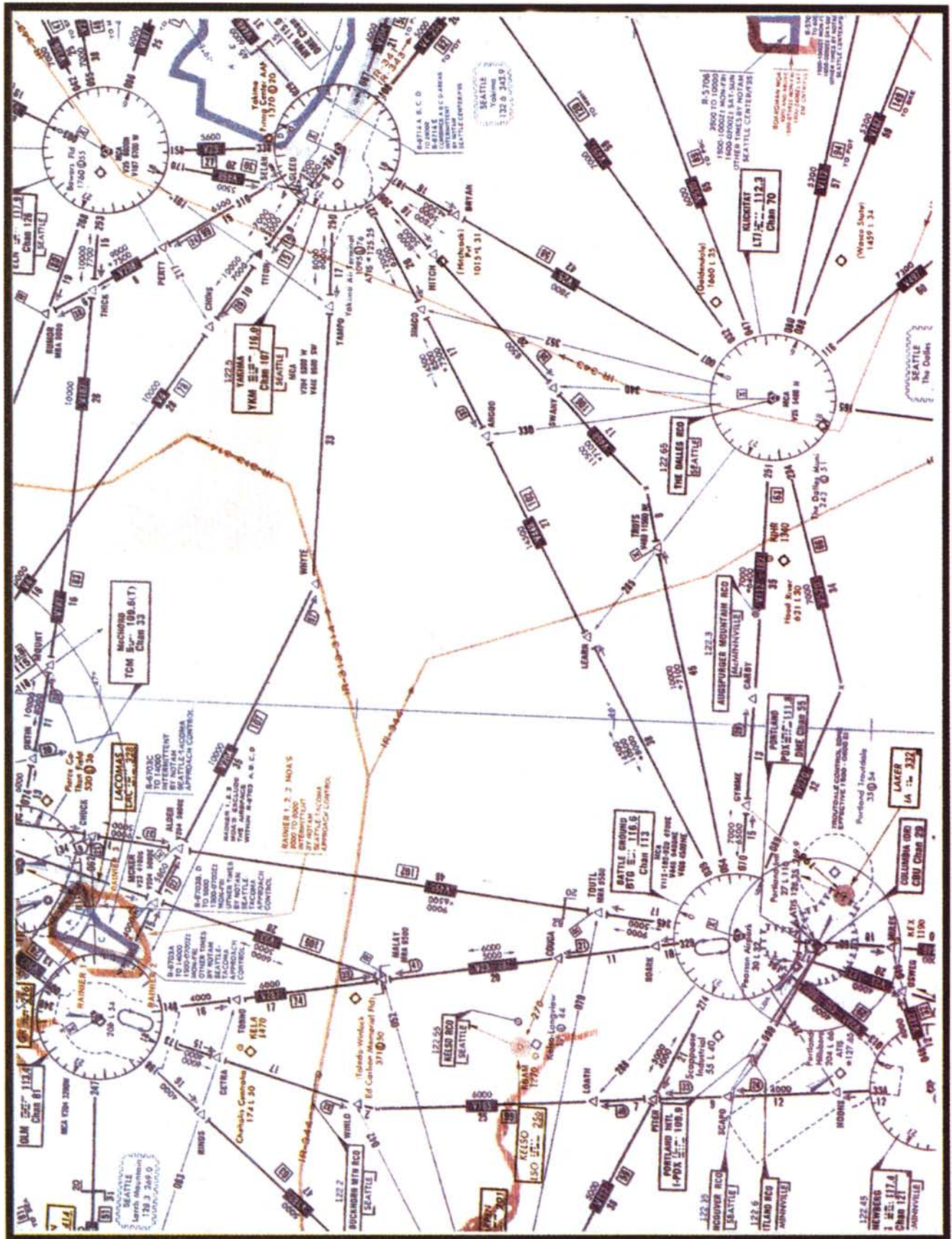

FIGURE 55.—En Route Low Altitude Chart Segment.



FIGURE 56.—Two signs.



FIGURE 57.—Sign.

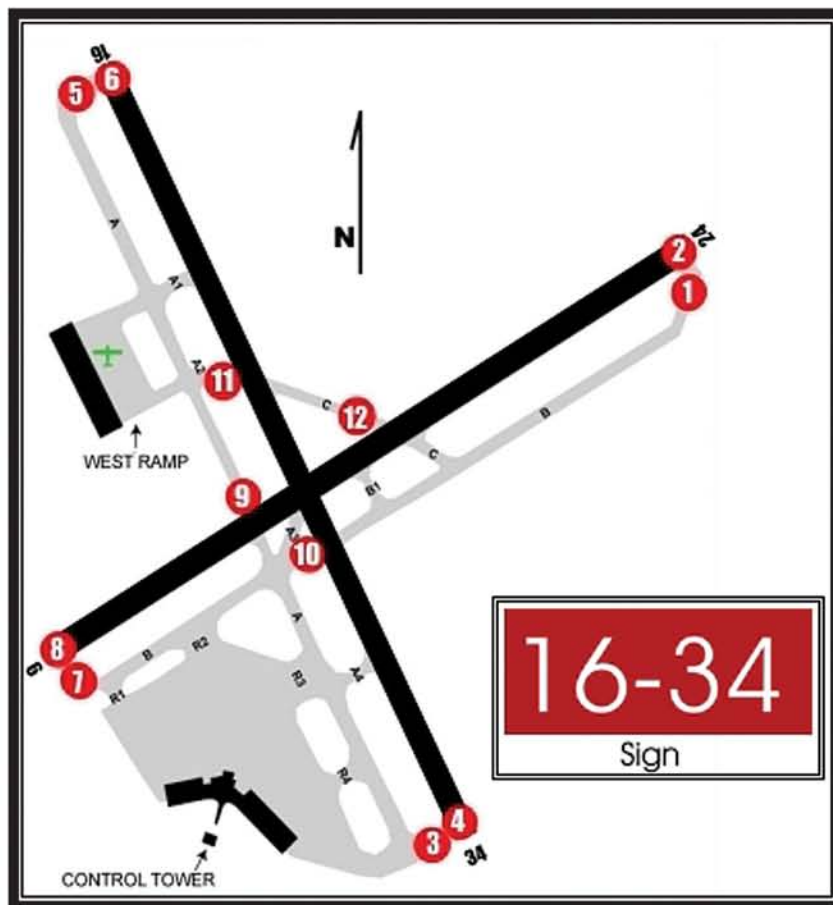

FIGURE 58.—Airport Diagram and Sign.

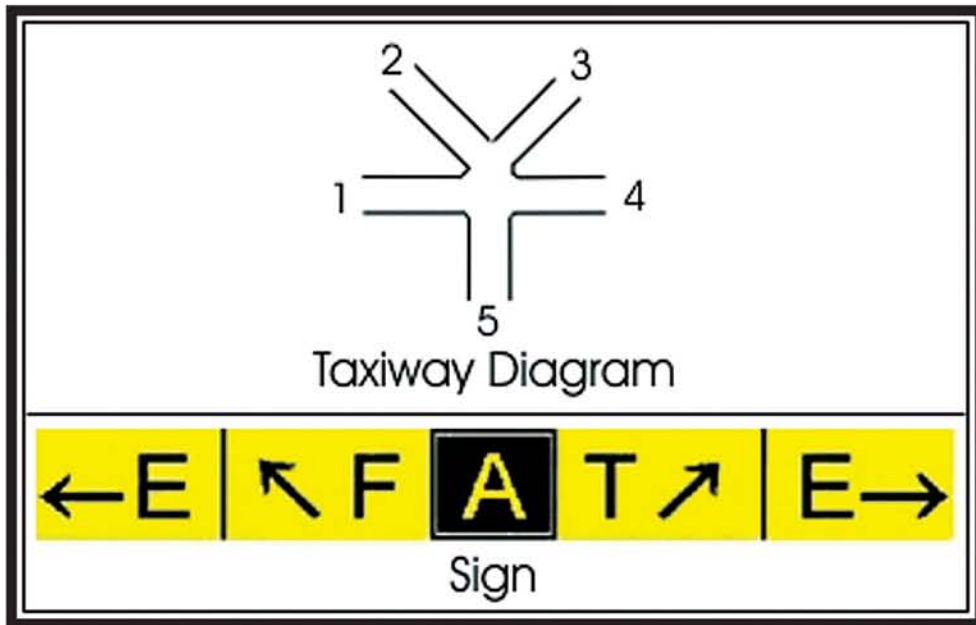

FIGURE 59.—Taxiway Diagram and Sign.

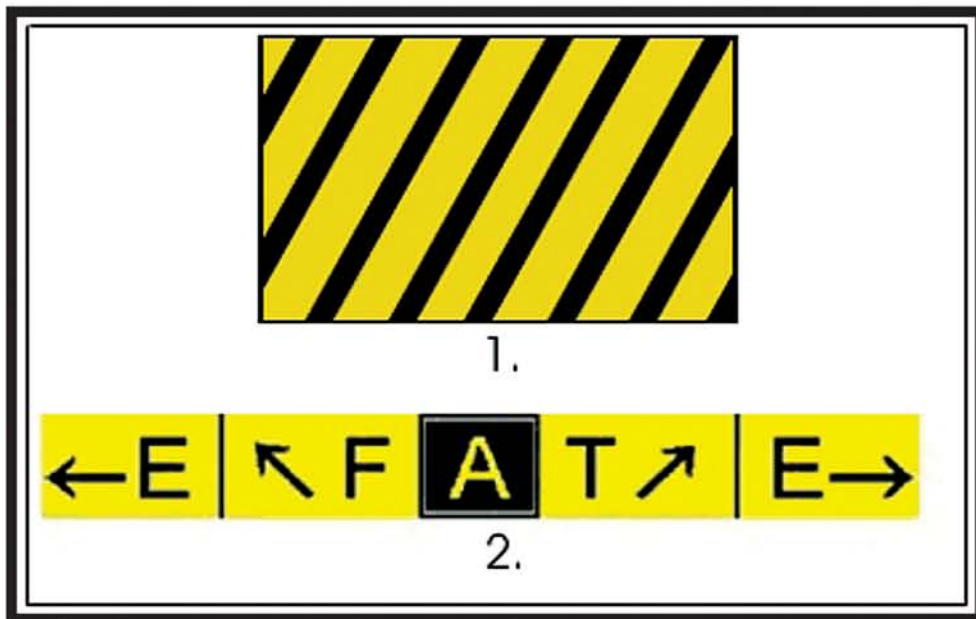

FIGURE 60.—Two signs.





FIGURE 61.—Sign.



FIGURE 62.—Sign.

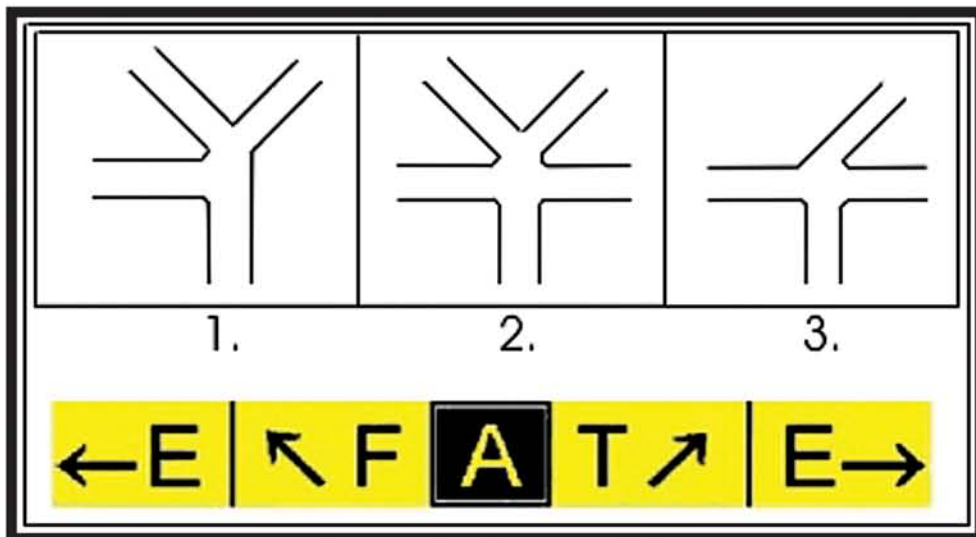

FIGURE 63.—Sign and Intersection Diagram.



FIGURE 64.—Sign.



FIGURE 65.—Sign.