

**BIENNIAL REPORT TO CONGRESS**

**ON THE STATUS OF**

***GPO Access***

**A Service of the U.S. Government Printing Office**

**Established Under  
Government Printing Office Electronic Information  
Access Enhancement Act of 1993**

**Public Law 103-40 – June 8, 1993**

**U.S. Government Printing Office  
December 31, 1995**

For additional information contact the Office of Congressional, Legislative and Public Affairs  
• U.S. Government Printing Office • Washington, DC 20401 •  
Telephone: (202) 512-1991

## TABLE OF CONTENTS

	Page
I. Overview	1
II. Key Provisions of the <i>GPO Access</i> Legislation	2
III. Statement of GPO Objectives	3
IV. Consultation	4
V. Online Access to the <i>Congressional Record</i> and <i>Federal Register</i>	5
VI. The Locator Service	9
VII. The Storage Facility	12
VIII. The Federal Bulletin Board	13
IX. Future Plans	14
X. Costs and Financing	16

### List of Exhibits

Exhibit A:	Legislative History of Public Law 103-40
Exhibit B:	Current Equipment Configuration for the <i>GPO Access</i> Service
Exhibit C:	<i>GPO Access</i> Now Free! (Press Release, December 1, 1995)
Exhibit D:	List of Databases Available Online Via <i>GPO Access</i> as of December 1, 1995
Exhibit E:	<i>Federal Register</i> Page with Instructions for Free Online Access; ACFR Resolution Supporting Free Public Access
Exhibit F:	<i>Congressional Record</i> Page with Instructions for Free Online Access
Exhibit G:	Sample Screens from the GPO World Wide Web Site
Exhibit H:	1994 Federal Technology Leadership Award (Press Release, November 18, 1994); 1995 James Madison Award (Press Release, March 15, 1995)
Exhibit I:	Federal Depository Libraries Sponsoring <i>GPO Access</i> Gateways

## STATUS REPORT

# *GPO Access*

A Service of the U.S. Government Printing Office

### I. OVERVIEW

Early in the 103d Congress two similar bills (H.R. 1328 and S. 564) were introduced, leading to the enactment of Public Law 103-40, entitled the "Government Printing Office Electronic Information Access Enhancement Act of 1993" (*GPO Access*) on June 8, 1993.

The *GPO Access* legislation had bipartisan support. It was introduced in the Senate by Senator Wendell H. Ford (KY) and co-sponsored by Senator Ted Stevens (AK) and Senator Larry Pressler (SD). In the House it was introduced by Representative Charlie Rose (NC) and co-sponsored by Representative Newt Gingrich (GA), Representative Sam Gejdenson (CT), Representative Gerald D. Kleckza (WI), Representative Pat Roberts (KS) and Representative William M. Thomas (CA). President Clinton signed it into law on June 8, 1993.

When it was launched in June, 1994, the *GPO Access* service was a combination of free services at and through Federal depository libraries and direct subscription services. On December 1, 1995, the Public Printer announced that *GPO Access* would be available without charge to all users. The press release announcing free public access is attached as Exhibit C.

As required, the *GPO Access* services were made available on June 8, 1994. The initial online databases were the *Congressional Record*, the *Federal Register*, the *Congressional Record Index* and Enrolled Bills. By September 30, 1995, the available databases had expanded to include all Congressional Bills, the History of Bills from the *Congressional Record Index*, the *United States Code*, Public Laws, and General Accounting Office (GAO) Reports. In early October, 1995, the following additional databases were added: the *Congressional Directory*; *Economic Indicators*; the *Government Manual*; House and Senate Calendars; House, Senate, and Executive Reports; House, Senate, and Treaty Documents; and several Government Information Locator Service (GILS) databases. A complete list of the *GPO Access* databases is provided in Exhibit D.

The *GPO Access* service has won two awards: the 1994 Federal Technology Leadership Award from *Government Executive* magazine and the 1995 James Madison Award from the Coalition on Government Information. The press releases announcing these awards are attached as Exhibit H.

Over 700 subscriptions were ordered during the first three weeks of operation and thousands of inquiries were received and processed. One year later, there were 6,900 workstations registered. By December 1, 1995, when free access was announced, there were over 8,900 workstations registered, approximately 80% from depository libraries or depository gateways.

From August, 1994, through September, 1995, there were approximately 730,000 searches conducted, resulting in the downloading of over 2.9 million documents from the *GPO Access* databases. By December 1, 1995, the *GPO Access* databases had responded to over 1.4 million searches, resulting in the downloading of more than 5.7 million documents, and usage has increased dramatically since the availability of free public access.

A brief legislative history is attached as Exhibit A. A diagram of the current equipment configuration for the portions of *GPO Access* that are accessible to the public is attached as Exhibit B.

## II. KEY PROVISIONS OF THE *GPO ACCESS* LEGISLATION

Summarized below are the key provisions of the Government Printing Office Electronic Information Access Enhancement Act of 1993 (Public Law 103-40).

### 1. Electronic Directory, Online Access and Storage Facility

Under the *GPO Access* legislation, the Superintendent of Documents is required to (1) maintain an electronic directory of Federal electronic information (the Locator Service); (2) provide a system of online access to the *Congressional Record*, the *Federal Register* and other appropriate publications (the Online Interactive Service); (3) operate an electronic storage facility for Federal electronic information (the Storage Facility). Collectively these are referred to as *GPO Access*.<sup>1</sup>

### 2. Departmental Requests

To the extent practicable, the Superintendent of Documents will accommodate requests by department or agency heads to disseminate their information through *GPO Access*.

### 3. Consultation

The Superintendent of Documents will consult with users of *GPO Access*, and with other providers of information services, to assess the quality and value of these services.

### 4. Fees

The Superintendent of Documents may charge reasonable fees for use of *GPO Access* services, except that Federal depository libraries will have access at no charge. If fees are charged, they must be set so as to recover the incremental cost of dissemination. Depository library access will be paid from the appropriation provided for the Federal Depository Library Program.<sup>2</sup>

### 5. Status Report: Biennial Report

By June 30, 1994, the Public Printer shall submit to Congress a report on the status of the *GPO Access* services. The Public Printer must submit to the Congress a biennial report, beginning December 31, 1995, on odd-numbered years. This report shall include a description of the functions in this Act and a statement of cost savings in comparison with traditional forms of information distribution.

### 6. Operational Deadline

*GPO Access* shall be operational by June 8, 1994.

---

<sup>1</sup>The Senate Report [103-27] acknowledged the existence of The Federal Bulletin Board and incorporated that service as well. A World Wide Web site [<http://www.access.gpo.gov>] was added in October, 1994, and significantly expanded in June, 1995. It is now a significant, and growing, component of *GPO Access*.

<sup>2</sup>As noted in Section II, when it was introduced in June, 1994, the *GPO Access* service was a combination of free services at and through Federal depository libraries and direct subscription services. On December 1, 1995, the Public Printer announced that *GPO Access* would be free to all users.

### III. STATEMENT OF GPO OBJECTIVES

When it was introduced in June, 1994, the *GPO Access* service was available for free public use on site at Federal depository libraries and from GPO as a subscription service. By October, 1994, free public use was extended to remote users accessing the services through depository library "Gateways." On December 1, 1995, the Public Printer announced that *GPO Access* would be available without charge to all users. This free public access is made possible through the Congressional funding of the Federal Depository Library Program.

Following is a listing of the objectives that guide the development of *GPO Access* services. These have evolved from the objectives agreed upon as governing principles in the initial endeavor, but remain substantially unchanged.

- To improve access to Federal Government information in electronic formats by defining a life cycle beginning with the original document created by the author and ending with archiving in appropriate data formats.
- To provide services for electronic document delivery and online interactive access that are well-designed, easy to use, and available to the public without charge through the Federal Depository Library Program.
- To assure access to a broad spectrum of users with a wide variety of technical capabilities, both directly and through an active partnership with Federal Depository Libraries. GPO will utilize network access, particularly the Internet, as well as the more traditional asynchronous (telephone and modem) communications as a means of direct access to its online information services. This will be augmented by depository libraries that (a) provide public access terminals, so that users without computer equipment can go to the library to obtain access, and (b) operate Gateways, so that users without Internet access can connect to the library by modem using a local telephone call, and the library can connect them to *GPO Access* through the Internet. A complete list of the *GPO Access* Gateways is provided in Exhibit I.
- To establish and operate an Online Interactive Service that is capable of rapid expansion to meet the needs of agency publishers and public users. Initially, the Online Interactive Service provided access to seven databases, including, as required by statute, the *Congressional Record* and the *Federal Register*. The service has already expanded to offer more than twenty-four databases.
- To coordinate and facilitate the operation of a comprehensive Locator Service, or Pathway, for Federal electronic information products and other appropriate Government information. This service will be compliant with, and facilitate the implementation of, the Government Information Locator Service (GILS) mandated by the Paperwork Reduction Act (Public Law 104-13).
- To establish and operate an electronic Storage Facility for Federal electronic information to which online access is provided, in order to assure availability of electronic information beyond the short-term use for producing print products or initial electronic dissemination.
- To encourage the use of electronic database standards, such as SGML-structured data files; industry standard page description languages, such as PostScript; and standardized document interchange file formats, such as the Acrobat Portable Document Format (PDF), that permit dissemination of the original document, without rekeying, in print and/or electronic format.
- To utilize a variety of dissemination media and methods to achieve cost-effective information delivery that is appropriate to both the type of information being disseminated and the needs of users of that

information, including online interactive search and retrieval; World Wide Web and bulletin board services; CD-ROM; magnetic tape, cartridge or diskette; facsimile transmission; and satellite broadcast or other affirmative transmission.

- To keep system development and operating costs low and manage growth carefully in order to keep the costs to publishing agencies and the Federal Depository Library Program as low as possible while permitting GPO to recover its costs.
- To establish and expand the *GPO Access* services as part of an agency-wide initiative which anticipates future workforce, technology and budget requirements.

Multi-disciplined organizational elements selected from within GPO were assigned critical tasks to facilitate initial implementation of Public Law 103-40. Managers from these organizational elements formed a Task Force to plan and coordinate its implementation to assure timely, cost-effective completion of the necessary tasks. This Task Force has been the basis for the ongoing cooperative efforts within GPO to operate, expand and enhance *GPO Access* services.

#### IV. CONSULTATION

In developing and implementing *GPO Access*, the Public Printer, the Superintendent of Documents, and other GPO staff have consulted with a variety of publishers and users of electronic government information, both from within and outside of the Federal government. Presentations have been made at numerous public meetings, including the Federal Depository Conferences, meetings of the Depository Library Council to the Public Printer, the Electronic Media (E-Media) conferences held as part of the National Information Infrastructure initiative, as well as local, regional and national library association meetings. Demonstrations and presentations have been made individually and in small groups to representatives of a variety of Congressional offices, Federal agencies, trade and professional organizations, and companies as well as to the general public. Presentations and training sessions have been held in eighteen states and the District of Columbia; public outreach sessions have been held in ten cities and the District of Columbia. There have been numerous letters, telephone calls and electronic mail messages from individuals and organizations seeking information about the implementation of the *GPO Access* legislation and offering their comments. These have been answered individually.

The *GPO Access* User Support Team was established to assist users and answer questions from potential users. The team collects comments and suggestions from more than 1,300 hundred telephone calls each week, and this information is used to improve the existing services and as an aid in determining the content and characteristics of future services. During the past six months, the User Support Team has handled approximately 33,000 user support calls.

We have also conducted two surveys of *GPO Access* users. The first survey was conducted in November, 1994, and went to all subscribers to the *GPO Access* Congressional Bills database. It obtained information from users that resulted in enhancement of that database at the start of the 104th Congress. The second survey was conducted in December, 1995, to obtain information on customer satisfaction. This survey were sent to all *GPO Access* subscribers. *GPO Access* received its strongest positive ratings for data reliability (96.9%) and for providing timely access to the *Record*, *Register* and Congressional Bills (97.5%). Ratings for ease of access and quality of user support are also good. The "typical" survey respondent accesses the databases with WAIS client software (45.4%) from 1 to 10 times per week (80.1%).

From its inception there was strong interest in having the *GPO Access* services available without charge to all users, not just those who could come to, or through, a Federal depository library. Recommendations to this effect were received from a number of individuals and organizations, including the Depository Library Council to the Public Printer.

## V. ONLINE ACCESS TO THE *CONGRESSIONAL RECORD* AND *FEDERAL REGISTER*

Under the *GPO Access* legislation, the Superintendent of Documents is required to provide a system of online access to the *Congressional Record*, the *Federal Register* and other appropriate publications (the Online Interactive Service). The initial implementation of the Online Interactive Service uses a Wide Area Information Server (WAIS) at GPO. It provides full text search and retrieval for the *Congressional Record* and the *Federal Register* and a growing number of other databases.

When the *GPO Access* services were made available on June 8, 1994, the initial online databases were the *Congressional Record*, the *Federal Register*, the *Congressional Record Index* and Enrolled Bills. By September 30, 1995, the available databases had expanded to include all Congressional Bills, the History of Bills from the *Congressional Record Index*, the *United States Code*, Public Laws, and General Accounting Office (GAO) Reports. In early October, 1995, the *Congressional Directory*; *Economic Indicators*; the *Government Manual*; House and Senate Calendars; House, Senate, and Executive Reports; House, Senate, and Treaty Documents; and several Government Information Locator Service (GILS) databases were made available. A complete list of the *GPO Access* databases is provided in Exhibit D.

### 1. Initial Requirements

In designing the initial WAIS server applications, GPO identified requirements that this service should:

- Be capable of meeting the operational deadline stipulated in the law.
- For the most part, utilize existing equipment, in order to minimize costs.
- Be compatible and work with Internet, as well as accessible through asynchronous communications (telephone and modem).
- Satisfy publisher and public requirements that online access to the *Record* and *Register* include the complete publications, including all tables, graphics, etc.
- Include at least one means of access that is compliant with the Americans With Disabilities Act (Public Law 101-336)

Although the above requirements were met with the WAIS server, additional requirements were identified that mandate the employment of alternative methods with a longer development cycle. These are discussed in Section IX: Future Plans.

### 2. Mandatory Databases on the WAIS Server

The *GPO Access* databases required by Public Law 103-40 are the *Congressional Record* and the *Federal Register*.

- *Congressional Record Online via GPO Access* contains daily issues of the *Congressional Record* from the 103d Congress, 2d Session (Volume 140, 1994) forward. The 1995 database is usually updated between 9:00 and 11:00 a.m. each day the *Record* is published, but the schedule varies depending on the time that Congress adjourns the preceding day. The text of the Daily Digest, Extensions of Remarks and House and Senate pages are all included in the database as ASCII text files. From the 104th Congress, 1st Session (Volume 141) forward, the *Record* is also available in the Adobe Acrobat

Portable Document Format (PDF). This allows users with the free Acrobat Reader software to display and print the typeset pages of the *Record*, including the graphics. The 1995 database also offers searching by date or page number and the ability to easily limit searches to specific sections of the *Record*. For the 1994 *Record*, all graphics are available as individual scanned-image files in TIFF format.

• *Federal Register Online via GPO Access* contains daily issues of the *Federal Register* from the beginning of calendar year 1994 (Volume 59) forward. The database is updated by 6:00 a.m. each day the *Register* is published. The text of Notices, Final Rules, Proposed Rules, Presidential Documents, and Executive Orders, as well as the contents and finding aids, are included in the database as ASCII files, with all graphics included as individual scanned-image files in TIFF format. Brief ASCII text summaries of each major entry are also available. From the beginning of calendar year 1995 (Volume 60) forward, the *Register* is also available in the Adobe Acrobat Portable Document Format (PDF). This allows users with the free Acrobat Reader software to display and print the typeset pages of the *Register*, including the graphics. The 1995 database also offers searching by date or page number and the ability to easily limit searches to specific sections of the *Register*. For the 1994 *Register*, all graphics are available as individual scanned-image files in TIFF format.

The Unified Agenda, also known as the Semi-Annual Regulatory Agenda, is provided from the first issue of calendar year 1994 (Volume 59). The database is updated twice a year when the Agenda is published. The text of the Unified Agenda is included in the database as ASCII files. From 1995 (Volume 60) forward, the Agenda is also available in the Adobe Acrobat Portable Document Format (PDF). This allows users with the free Acrobat Reader software to display and print the typeset pages of the Agenda.

### 3. Methods of Access; Software

Users with full Internet access (or a SLIP/PPP connection through an Internet service provider) and either a World Wide Web browser or local WAIS client software can search all of the *GPO Access* databases and retrieve the text files as well as the TIFF files containing scanned-image graphics and the Adobe Acrobat PDF files for all databases that offer those options. Customized WAIS client software for Windows or Macintosh systems is available from GPO for \$15 per copy. Sample searches and the appropriate source selections (database addresses) are provided with this client software and the installation has been customized for the special file format requirements of the *GPO Access* databases. The WAIS client software also includes a text viewer and a graphics (TIFF) viewer. The Acrobat Reader software is available free of charge from Adobe Systems, Inc., and a number of other sources, including several *GPO Access* servers.

Those who do not have full Internet connections can still use the *GPO Access* databases through the Simple WAIS (SWAIS) client software on the GPO server. This provides the ability to search the ASCII text files through an Internet Telnet session or by using a modem to dial directly into GPO and offers a means of access that is compliant with the Americans With Disabilities Act. Graphic (TIFF) and Acrobat PDF files are not available through SWAIS.



A substantial number of Federal depository libraries have Internet service and can use SWAIS, a Web browser, or the customized WAIS client software to search the *GPO Access* databases. GPO provides limited 800 service for a small number of depository libraries that do not have, and cannot obtain, Internet service, and are outside of the Washington metropolitan area. Because of the potential expense, GPO anticipates that this will be only a short term solution, and that the depository libraries will actively seek to obtain Internet access. Depository libraries using this service have special procedures to follow and are issued an identification number to use in conjunction with the 800 number. They are limited to SWAIS service.

#### 4. Federal Depository Library Access; Gateways

As required by Section 4102 of the *GPO Access Act*, the Superintendent of Documents is providing Federal depository libraries with access to the *GPO Access* databases without charge. The libraries, in turn, provide free public access to these services. There is at least one Federal depository library in most Congressional Districts. Costs for this access are paid from the appropriation provided for the Federal Depository Library Program.

Initially each depository library was offered one subscription to the online databases. During June and July, 1994, GPO considered additional means to improve public availability of the *GPO Access* services, resulting in the decision in October, 1994, to expand the availability of *GPO Access* by offering a maximum of ten subscriptions to each depository library and by encouraging depository libraries to use the expanded subscriptions to develop public access "gateways" to *GPO Access*. In general, the gateway concept was to utilize existing depository library networks or allow depository libraries to partner with public access networks in their local area. Members of the public would connect to the depository library gateway host, which in turn would establish a transparent connection to the *GPO Access* online services. This action was lauded as "a major breakthrough in the way the Federal government distributes information to the public."<sup>3</sup>

The availability of additional subscriptions permitted the rapid expansion of the number of public access workstations available for use on-site in depository libraries. This is particularly important for the many individuals who cannot access online services from their home or office, and therefore, must rely on equipment and communications services at depository libraries. This approach also capitalized on strengths of the FDLP, by involving the professional documents librarians as intermediaries to assist the public with the service.

The initiative to establish gateways enabled free, off-site, public access to the *GPO Access* services, around the clock, from users in classrooms, offices, or homes. All depository libraries are eligible to become gateway sites, either on their own, or in partnership with public networks. Users can connect to a gateway by using a computer with a modem or through the Internet. GPO's initial goal was to have at least one gateway in each state, to reduce the necessity for long distance calls by remote users.

The first gateway was a partnership effort between the regional depository library at the University of Missouri at Columbia and COIN, the Columbia Online Information Network, a community network. The second gateway at Seattle Public Library. Both became operational in October, 1994. Nine gateways were operating by the end of March, 1995, and by December, 1995, there were 26 gateways serving the public in 20 states and Washington, D.C. Over eighty depository libraries or public network partners have contacted GPO about becoming a gateway, with more contacts coming in daily. Geographic coverage, based on these expressions of interest, spans all 50 states, Washington, D.C., and the U.S. Virgin Islands. A complete list of the current gateways is attached as Exhibit I.

---

<sup>3</sup>"Citizen Groups Laud GPO for Free Online Access to Federal Legislation Texts, Congressional Record, Federal Register." News Release dated October 6, 1994, from Taxpayer Assets Project and Congressional Accountability Project.

Most of the early gateways elected to offer the SWAIS terminal emulation interface for *GPO Access*. Other gateway partners have elected to offer capabilities beyond SWAIS. For example, the University of North Carolina developed a WAIS client using a Lynx Web browser and html (hypertext markup language) for menus and instructional screens. In May, 1994, Purdue University opened the first Web gateway to *GPO Access*. Since then nearly all of the gateways have used Web home pages to launch sessions with *GPO Access*.

The gateway libraries accept full responsibility for providing user support to both on-site and off-site users. Some of these responsibilities include connection of off-site users to the gateway server, use of communications software, and assisting users with limited technical expertise.

The availability of gateways resulted in a substantial increase in traffic on the *GPO Access* service, and it became clear that gateways would eventually result in a decrease in the sale of subscriptions. As a result of the growing availability of no-charge access, to reduce administrative costs, and to promote public access, the decision was reached that the FDLP was the proper channel for *all* public use of the *GPO Access* services, and on December 1, 1995, Public Printer Michael F. DiMario announced that the public could have free access to *GPO Access* services, directly from GPO or at or through a Federal depository library.

#### 5. Fees Prior to Free Public Access

Fees for *GPO Access* were set so as to recover the incremental cost of dissemination. Section X contains additional information on the costs for the development and operation of the *GPO Access* services.

Until free public access was announced on December 1, 1995, databases were grouped into one of three subscription services: the *Federal Register* service, the *Congressional Record* service, and the Legislative service. The subscription fees for any one of these services were as follows:

- The annual subscription price for a single workstation (not a server) or an individual user-id was \$375. Six-month (26 week) subscriptions were available for \$200. One month (30 days) of access could be purchased for \$35.
- Annual subscriptions were also available for multiple workstations. Rates were as follows:

2 to 10 Workstations:	\$750 per year
11 to 50 Workstations:	\$1,875 per year
51 to 100 Workstations:	\$2,815 per year
101 to 150 Workstations:	\$3,755 per year
151 to 500 Workstations:	\$3,755 per year plus \$188 per 10 additional workstations over 150 (round up)
501 to 1000 Workstations:	\$10,335 per year plus \$94 per 10 additional workstations over 500 (round up)

A special comprehensive service provided an annual subscription price for all *GPO Access* databases for a single workstation (not a server) or an individual user-id for \$995, with a comparable scale for multiple workstations. The above rates were based on GPO's best estimates of the number of subscriptions that would be sold, or delivered without charge to Federal depository libraries, during the first year of service. An assessment in August, 1995, confirmed that *GPO Access* had reached full cost recovery; however, approximately 80% of the revenue was from subscriptions for Federal depository libraries purchased using the S&E appropriation.

A brochure that is used to respond to customer inquiries and otherwise promote the *GPO Access* services is attached as Exhibit D, along with a list of the available databases. A reproduction of the *Federal Register* page providing the instructions for free access to the online *Federal Register* that appears in each daily issue is in

Exhibit E, along with a resolution from the Administrative Committee of the Federal Register (ACFR) supporting free public access. A reproduction of the instructions for free access to the online *Congressional Record* that appears in each daily issue is Exhibit F.

6. Equipment

At present the equipment acquired as the hosts for the *GPO Access* WAIS applications are DEC 3000 Model 600 Alpha Workstations, running OSF/1. Each server has over 36 gigabytes of hard disk storage. The primary application software is WAIS Server 2.1.2 from WAIS, Inc.

## VI. THE LOCATOR SERVICE

Under the *GPO Access* legislation, the Superintendent of Documents is required to maintain an electronic directory of Federal electronic information (Locator Service). The idea of a Federal locator or directory for electronic data files is not a new one. There have been a number of studies and legislative initiatives seeking to address the vast quantity of government information that is not easy to acquire in large part because it is not easy to find.

Assignment of the responsibility for a government-wide locator to GPO is a logical extension of its responsibility for the publication of the *Monthly Catalog of U.S. Government Publications* (MoCat). Title 44 USC §1711 requires GPO to "prepare a catalog of Government publications which shall show the documents printed during the preceding month, where obtainable, and the price." MoCat production receives modest funding (about \$2.5 million a year) as part of the Legislative Branch Appropriations to fulfill the requirements of Title 44.

MoCat lists a wide variety of paper, microform and electronic government publications -- over 32,000 records per year. However, coverage of electronic information products has largely resulted from the inclusion of CD-ROM and diskette based products in the GPO Sales Program and obtained for distribution to Federal depository libraries. While it is not limited to such items, that has been a major source of information for MoCat.

The new legislation gives GPO the responsibility to provide a more comprehensive directory or locator of electronic information available from the Federal government. Consequently, GPO established a contract with the University of Kentucky Research Foundation, on behalf of the University of Kentucky and the National Distance Learning Center, to develop a Prototype Locator. The contract was for \$380,000 and it was completed in December, 1994.

The information gained from the development of the Prototype Locator, in combination with the rapid expansion of the World Wide Web as a tool for sharing information through the Internet, led to the introduction of the *GPO Access* Locator Service as a component of the Superintendent of Documents' Home Page on the GPO Web site in June 1995. Sample screens from the GPO Web site are attached as Exhibit G.

### 1. Characteristics of the Locator Service

It is important to understand that the Locator Service is intended to identify and describe – but not necessarily to directly deliver – the full content of information resources in response to a user query. As presently implemented, the *GPO Access Locator Service*:

- Provides users with descriptive data on a wide variety of Federal information services and products as well as facilitating access to the referenced information.
- Uses linkages to integrate the locator applications with the other components of *GPO Access* on the Superintendent of Documents World Wide Web site, including the online databases available through the WAIS server.
- Is compliant with, and facilitates the implementation of, the Government Information Locator Service (GILS) mandated by the Paperwork Reduction Act (Public Law 104-13).
- Is accessible to a wide range of users through the Internet at no charge.
- Refers users to holdings of Federal depository libraries and takes orders for the GPO Sales Program.
- Provides the basis for an extensive Pathway to Federal government information.

### 2. GPO's Roles in the Locator Service

In developing the *GPO Access Locator Service*, GPO sought to design a system that permits and encourages agencies to make data about their electronic information available locally, in a distributed system, under the control of the participating agencies, while also offering GILS-compliant locator development services and the opportunity for agencies to utilize GPO's Web and WAIS servers to disseminate their locator information. The GPO Web site thus acts as a major host for locator applications and a point-of-entry to identify and link to locator applications at other sites. As the point of entry, *GPO Access* will be the place where a user might start if they are not sure which agency is likely to have information that would assist them.

GPO will publicize the availability of the *GPO Access Locator Service* and assist users in making their initial connection to it. Although GPO will not be the only source for locating Federal information, GPO is committed to offering services that go beyond the requirements of GILS and offer depository libraries and the public enhanced capability to locate and obtain Federal government information. The current locator applications exemplify this commitment and demonstrate some of the means by which it will be met.

### 3. Current Locator Applications

The *Monthly Catalog of U.S. Government Publications (MoCat)* is one of the core applications for the current Locator. MoCat identifies print and electronic publications from a wide range of government agencies. The MoCat locator application permits the user to identify a document and then obtain a list of nearby Federal depository libraries that select that type of material. This application is augmented by a link to a Department of Energy Web application that links the Energy Reports Bibliographic Database that identifies depository libraries receiving DOE reports in microfiche.

Another core locator application is the development of GILS databases. In addition to establishing a GILS-compliant database for GPO's own information services, GPO has worked with the National Archives and Records Administration (NARA) and the Office of the Federal Register (OFR) to establish a central database that meets the obligations of all Federal agencies to have GILS records for their Privacy Act systems. Through

the Web, the Privacy Act database is linked to *Federal Register* notices that update the biennial compilation prepared by the OFR. As of December 1, 1995, GPO was developing GILS databases for dissemination through *GPO Access* for twenty other agencies. Each of these databases is accessible through WAIS, SWAIS and the Web, either individually or as a group. GPO is actively seeking the highest level GILS record for each Federal agency for incorporation into its own GILS database as well as creating its own Pathway GILS records to direct depository libraries and the public to important Federal agency information sources. This will provide a point-of-entry, or link, to assist the public in finding all of the sites in the Federal government where GILS records are available.

Finally, GPO is already identifying, evaluating and linking to Federal World Wide Web and Gopher sites to create a pathway through the maze of government information available on the Internet. At present this service provides information on a small number of sites and covers only three topics: Business, Cancer and Solar Energy. These entries are the initial paving stones along a Pathway that will eventually guide users in searching and discovering government information on a wide variety of topics.

#### 4. Future Locator Applications: Pathway Services

Pathway services will utilize information management skills of GPO staff and depository librarians as well as advanced indexing, search, and retrieval tools to identify, describe, and dynamically link users to Federal electronic information. Pathway will be an evolving system since indexing and Internet technology are constantly changing. The services will change as technology changes.

Pathway will link to Federal Internet sites which are operated by government agencies or in cooperation with government agencies. Pathway will analyze only Federal government electronic sites. These sites are limited to .gov and .mil Internet domains, and sites which are operated as official government sites in cooperation with private companies, universities or other organizations. Pathway will link to these sites by two methods. One is the use of an indexer which will generate an index of electronic government sites. The other is the use of GPO staff to categorize government sites by subject and arrange them by organizational structure.

The Pathway index will enable an individual to find specific government information on any topic, using their own words to structure a search. It will index not only GILS records, but the words on Web pages and Gopher menus as well. This is similar to other applications using web indexers or crawlers, but it will be the first such effort to focus exclusively and comprehensively on Federal government information.

The Pathway will also identify government information sites by subject area and organizational structure and to provide links to them. This categorization of government sites by subject terms will be effective for those who wish to see what is available in broad subject areas.

As part of its future plans, GPO intends to review the government sites linked through its Pathway services in order to identify, and provide cataloging records for, specific electronic documents that should be available for long-term public access through the *GPO Access* services. This will require establishing relationships with the agencies that create and disseminate these documents, so that GPO can provide long-term access for the depository libraries and the public if the agency is unable or unwilling to do so at some future time.

#### 5. Free Public Access: Methods of Access

The FDLP will fund access to the Locator Services for depository libraries and the general public. These costs will be paid from the appropriation provided for the FDLP in the Legislative Branch Appropriation.

Currently users can access the Locator Service through an Internet Lynx session or by using a Web browser. The address is <http://www.access.gpo.gov>. The page for the locator services can be accessed directly by adding [/su\\_docs/aces/aces700.html](http://su_docs/aces/aces700.html).

## 6. Equipment

At present the equipment acquired as the host for the GPO World Wide Web applications, including the Locator Service, is a DEC 1000 Model 4/200 Alpha Workstation, running OSF/1. This server has over 7 gigabytes of hard disk storage.

## VII. THE STORAGE FACILITY

The *GPO Access* legislation requires the GPO to "operate an electronic storage facility for Federal electronic information to which online access is made available." This facility began receiving data on March 31, 1994. It is located in Owensboro, Kentucky.

### 1. Purposes; Methods of Access

The Storage Facility permits GPO to retain electronic files for extended periods of time after their short-term use for production of print products or active electronic dissemination, and it provides a mechanism for access to and retrieval of stored data files as a service to Federal agencies, depository libraries and the public. It will be a major component of the Federal Depository Library Program which is rapidly evolving from the distribution of print and microfiche documents into an almost entirely electronic access and dissemination service.

Data files in the Storage Facility will be referenced in the Locator Service to facilitate identification and retrieval. The FDLP will fund the storage of electronic documents created or obtained for Federal depository libraries as well as access to the Storage Facility for depository libraries and the general public. Agencies will be able to reimburse the costs for storing files that are not selected for inclusion by the FDLP.

The facility is currently accessible through the Internet. Users can search the *GPO Access* databases using either a Web browser or local WAIS client software as well as through the Simple WAIS (SWAIS) client software on the GPO server.

### 2. Content

The Storage Facility provides immediate remote access to the historical databases from the *GPO Access* online services, thus assuring that these files are never "out of print." The initial data sets in the Storage Facility include the 1994 *Congressional Record* and *Federal Register*, the *Congressional Record Index* from 1992 through 1994, and *Congressional Bills for the 103d Congress (1993-1994)*. This information is currently available as WAIS databases. The text files from these databases are ASCII files, with graphics from the *Record* and *Register* stored as separate files in the TIFF format. Congressional bills are also available as Adobe Acrobat PDF (portable document format) files. The volume and variety of information will increase as additional information is disseminated through the *GPO Access* online services.

In the future, the Storage Facility will also be used as the original point for storing and providing on-demand access to data files that are anticipated to have limited usage and/or are not appropriate for dissemination through the other online services.

### 3. Equipment

The current equipment includes a DEC 3000 Model 400 Alpha Workstation running OSF/1, with 36 gigabytes of hard disk capacity. GPO is evaluating the use of a CD-ROM jukebox and/or an optical disc jukebox for storage of document images and other files not suitable for full-text retrieval.

## VIII. THE FEDERAL BULLETIN BOARD

The House and Senate Reports on the *GPO Access* legislation acknowledged the existence of The Federal Bulletin Board and incorporated it into *GPO Access*.

### 1. Purpose

The bulletin board service (BBS) enables Federal agencies to provide the public with immediate, self-service access to Government information in electronic form. Like the Storage Facility, it provides a means for on-demand delivery of information that is not suitable for, or not time sensitive enough to warrant, online interactive access. Consequently, GPO is evaluating the feasibility of incorporating the bulletin board as a component of the Storage Facility. Since June, 1994, over 56,000 files have been download, transferring over 4.7 gigabytes of information to users of The Federal Bulletin Board.

### 2. Content of Files

As of September, 1995, the bulletin board has over 7,400 files representing more than 22 Federal agencies and organizations from all three branches of the Federal government, including files from such agencies as:

- Congress
- The Supreme Court
- Department of Justice
- Environmental Protection Agency
- Food and Drug Administration
- Government Printing Office
- Internal Revenue Service
- Office of Foreign Assets Control
- Public Health Service
- The White House
- Department of Energy
- Department of State
- Federal Highway Administration
- General Accounting Office
- Health Care Financing Administration
- Merit Systems Protection Board
- Office of the Federal Register
- Social Security Administration

The bulletin board includes files on subjects such as:

- Federal Budget
- Foreign Countries
- Health Care Reform
- Human Rights
- National Export Strategy
- National Performance Review
- Pending and Enacted Legislation
- Press Releases
- Federal Depository Library Program
- General Agreement on Tariffs and Trade (GATT)
- Iran-Contra Report
- National Information Infrastructure
- North American Free Trade Agreement (NAFTA)
- Proposed and Final Rules

This information is available in a variety of formats, including:

- ASCII
- PostScript
- Lotus 123
- Executable Software
- WordPerfect
- Acrobat PDF
- dBase

3. Methods of Access: Software

Currently users can access The Federal Bulletin Board through an Internet Telnet or FTP session addressed to fedbbs.access.gpo.gov or by using a modem to dial directly into GPO at (202) 512-1387. A variety of standard off-the-shelf communications software and Telnet or FTP session managers can be used to access the bulletin board.

4. Depository Library Access: Fees

Until December 1, 1995, Federal depository libraries had access to fee-based services of The Federal Bulletin Board without charge. Costs for this access were paid from the appropriation provided for the Federal Depository Library Program.

Fees for other users were set so as to recover the incremental cost of dissemination. Users did not pay a minimum fee or any charge for the time spent online. All charges were based on the size of file downloaded. The minimum charge was \$2 per file. The average price of a file downloaded from The Federal Bulletin Board was \$5. Payment methods included MasterCard, VISA, or GPO Deposit Account. Users were charged only when a fee-based file is downloaded.

The Federal Bulletin Board is now a free service as part of *GPO Access*. A few files, such a software requiring a licensing fee, continue to be sold through the bulletin board, and the online ordering requires payment for items purchased.

5. Equipment

The current equipment includes a 486 EISA computer, running DOS 6.22 as the operating system, with 2 gigabytes of hard disk capacity and a RAID Unit (Random Array of Inexpensive Disks) that provides 4 additional gigabytes of storage. The bulletin board software is The Major BBS 6.25 from Galacticcomm.

## IX. FUTURE PLANS

GPO concluded that the type of online interactive service that must be provided to meet the broader spectrum of Federal depository library and public needs while completely satisfying requirements of the Legislative Branch, requires a longer development cycle than the one year provided in the *GPO Access* legislation. Consequently, while developing the WAIS and WWW server applications to meet the statutory deadlines, GPO has also been working toward installation of an enhanced Online Interactive Service. This endeavor is commonly referred to at GPO as "Phase II." The necessary steps to fulfill these requirements are being taken and some preliminary results should appear online during 1996.



## 1. Use of SGML

GPO recognized that to garner potentially significant economies throughout the Federal sector, an acceptable standardized data structure must be employed. This structure should begin at the authoring level and remain usable throughout the publishing processes, whether publishing in electronic or traditional printed format. Standard Generalized Markup Language (SGML), prescribed by Federal Information Processing Standard 152, was selected as the appropriate means to accomplish these objectives. The use of SGML offers a far-greater potential for savings than methods presently employed, not only at GPO, but throughout the Federal sector.

Consequently, GPO is in the process of changing its production procedures to process the *Congressional Record* and *Code of Federal Regulations* (CFR), and related publications, using SGML. Preliminary Document Type Definitions (DTD's) for both the *Record* and CFR have been completed, and refinements will be made as we gain experience in actual production of these publications.

Input routines of GPO's PC-based composition software (MicroComp) have been modified to accept SGML-encoded data as input. GPO's markup personnel are receiving on-going training in its use. In addition to preparing documents in-house using SGML, GPO now offers training so that Federal agencies can incorporate SGML during their authoring process.

Use of this standardized data structure provides a coherent and unambiguous syntax for describing the elements of information in the textual data and delineating the inter-relationships between those elements, thus providing a greatly enhanced search and retrieval capability.

## 2. Software Procurement

A notice was published in the *Commerce Business Daily* on August 18, 1993, announcing that GPO would procure an off-the-shelf build engine and retrieval software site license for use in electronically disseminating Government publications. This software was to be used to produce CD-ROMs and online interactive databases from SGML-structured files.

A Request for Proposal (RFP) to procure this software was issued in mid-November 1993. A pre-proposal conference was held in December 1993. Although the RFP solicited commercially available software, GPO recognized that the procured software might require substantial customization for these particular applications and issued an amendment in March 1994, addressing these and other issues raised during the pre-proposal conference. Proposals were received in mid-May 1994, and a contract for SGML-based build/search/retrieval software was awarded to OpenText Corporation on November 3, 1995.

A provision of the contract allows 90 days for delivery of CD-ROM retrieval software which employs the same user interface and search conventions as those used in searching the online databases. This will permit users to employ the same criteria for searching both media, while obtaining like results. Training in the use of this software began December 18, 1995, for selected GPO employees.

## 3. SGML-Based Interactive Search and Retrieval

In addition to providing a greatly enhanced search and retrieval capability, five additional features of the Phase II service are regarded as very important. The SGML database structure will permit:

- Creation of databases at the authoring stage that are suitable for publication via conventional or demand printing methods, online interactive access and CD-ROMs, without the need for GPO to manipulate the data to produce one product or the other, and with the online and CD-ROM versions capable of employing the same user interface.

- Incorporation of data from one publication into another with a different printed format (such as Bills into the *Congressional Record* or *Federal Register* documents into the CFR) without manipulation.
- GPO to eliminate the need to re-key and proofread publication data, because it makes it possible for publishing customers to submit validated, machine-readable data.
- Automated composition (print on demand) of data extracted from electronically disseminated databases in the same format as the "official" printed publication, or in a variety format(s) chosen by the user.
- Exponential increases in the amount of Federal information that can be made available electronically to the public, if a conforming database is specified as a deliverable in future commercially-procured printing/information products, along with other requirements.

### 3. Alternative Forms of Dissemination

CD-ROM publications may be used to provide archival copies of the data from the Online Interactive Service and/or to serve users who cannot or do not choose to use the online services. These CD-ROMs will employ the same user interface as the Online Interactive Service, thus reducing retraining of users who do use both formats.

## X. COSTS AND FINANCING

Although no appropriations were made directly for the development of *GPO Access*, appropriations made to publishing agencies are available to create databases, maintain information in electronic formats, and otherwise participate in the *GPO Access* services. In the absence of appropriations to cover the other costs for maintaining the system and providing services to users, GPO must recover all such costs from the fees charged for its services and from the funds appropriated for the Federal Depository Library Program. Revenue from these sources totaled \$92,400 in FY 1994 and \$1,598,548 in FY 1995.

### 1. Sources of Funding

GPO is a self-supporting agency, receiving fees for its production and procurement services to Congress and Federal agencies and for its sale of Government information to the public. Publishing agencies, including the Congress, have paid, and generally will continue to pay, the "first copy" or development costs, as they do with current paper and CD-ROM products. This means that agencies have a very substantial voice in deciding on the content and characteristics of the services that GPO offers.

The Legislative Branch Appropriation includes funding for Congress' printing and binding through the annual Congressional Printing & Binding (CP&B) appropriation. It also provides funding for four programs, including the Federal Depository Library Program, through the annual Salaries & Expenses (S&E) appropriation. The appropriate congressional database development costs are being charged to CP&B. The expenses for Federal depository library use of the *GPO Access* services were charged to the S&E appropriation during FY 1994 and FY 1995.

During FY 1994 and FY 1995, when information was disseminated through the *GPO Access* services, the incremental cost of dissemination was recovered from the recipients or, in the case of the Federal depository libraries, from the S&E appropriation provided to the Superintendent of Documents for that program. This included any costs necessary for maintaining the system; providing user support; training and documentation; and software licensing fees, as well as general and administrative expenses.

The law requires that the *GPO Access* services be self-sustaining. As a result, the selection of publications and services to be offered will partially depend on:

- The willingness of publishing agencies to fund development of, and public access to, these services.
- The continued availability of funding for the Federal Depository Library Program to disseminate *GPO Access* services to the depository libraries and the public.

As currently occurs with other print and electronic publications, reimbursement for development costs incurred by GPO will come from fees paid to GPO by the publishing agencies or from the FDLF.

## 2. Pricing of Current and Future Services

GPO priced the online services at the estimated "incremental cost" as directed by law. *GPO Access* has reached full cost recovery; however, approximately 80% of the revenue was from subscriptions for Federal depository libraries purchased using the S&E appropriation. On December 1, 1995, Public Printer Michael F. DiMario announced that the public could have free access to *GPO Access* services, directly from GPO or at or through a Federal depository library.

When *GPO Access* began in June, 1994, GPO set up a subscription service. Rapid changes in technology and policy decisions promoting free access to government information made this subscription-based method of operation impractical and costly. GPO has taken steps to make it easier for the public to get government information online over the *GPO Access* service. It is now clear that no-charge access without the need for a subscription or registration promotes public use and reduces administrative costs. An increasing number of citizens are using the Internet to get information. Requiring subscriptions and computer addresses created artificial barriers and inhibited public access.

Under the subscription service, the incremental cost of dissemination was charged to subscribers. By far, the largest number of subscriptions went to Federal depository libraries, whose fees were paid by the Superintendent of Documents Salaries and Expense (S&E) appropriation. Other users paid for their own subscriptions. Because government information can now be obtained at no charge through various alternative sources, including the gateways sponsored by Federal depository libraries, the relatively small proportion of subscribers who paid their own fees was expected to disappear. Furthermore, the subscription service created substantial costs for taking orders, billing renewals, recording users' Internet Protocol addresses, maintaining customer information, and providing customer consultation and assistance.

GPO does not pay user telecommunications costs. Access via the Internet is growing rapidly. Depository libraries in many states are providing "gateway" connections, permitting public access with a local phone call for those who have modems. People without the appropriate computer equipment or skills can use *GPO Access* by visiting a depository library.

Providing general access at no-charge does not increase GPO appropriation requirements. It provides a proper incentive for agencies to publish in cost-effective electronic formats and eliminates certain administrative costs inherent in the earlier system. The net result of this action is dramatically reduced costs per transaction, as access is expanded. Information is more equitably available to educational institutions, public libraries, and others with limited resources.

### 3. Development Expenditures and Operating Costs

Capital expenditures for equipment and software for *GPO Access* (the Locator, the Online Interactive Service, and the Storage Facility) amounted to \$133,100 in FY 1994 and \$171,500 in FY 1995. In addition, there was a one time expense of \$380,000 in FY 1994 for the Prototype Locator Contract. Total GPO operating expenditures for FY 1994 were \$563,600 and for FY 1995 were \$1,222,700. Publishing agencies incurred additional expenses in developing databases for the online services and participating in the Locator Service.

### 4. Benefits and Savings from Dissemination of Electronic Information

Distribution of paper documents by the Document Sales Program and the Federal Depository Library Program has been declining for several years as agencies decrease their print publications and increase their electronic publications. While it is impossible to calculate exact savings to GPO and other government agencies, and to the public, an analysis of the *Federal Register* subscriptions confirms the trend. When the *Federal Register* Online via *GPO Access* was introduced in June, 1994, there were 19,775 subscriptions to the paper *Federal Register*. The price for a paper subscription was \$490 per year while the price for an annual subscription through *GPO Access* was only \$375, a difference of \$115. By September, 1995, subscriptions to the online *Federal Register* had reached 3,725 workstations and the paper subscriptions had dropped to 17,320 subscriptions. This indicates that online service has expanded access to the *Federal Register* to individuals who did not have subscriptions to the paper copies as well as replacing some paper subscriptions.

Between August, 1994, and December, 1995, there were approximately 620,000 searches of the online *Federal Register*, resulting in the retrieval of 2.9 million *Federal Register* documents. If one assumes that a search equates to the acquisition of a single issue of the *Register*, then *GPO Access* delivered the equivalent of 620,000 single issues which would have cost almost \$5 million, at \$8 each, if delivered as paper copies. These statistics also confirm that many individuals want only selected documents from the *Federal Register*, which can be most easily accomplished through electronic dissemination.

Net savings in terms of reduced distribution of paper copies, if any, as a result of online dissemination may not be realized for several years. Cost reductions due to electronic formats, including CD-ROM, can be substantial for individual publications, if paper copies are eliminated. Making information contained in government electronic databases available online promotes equity and accessibility in information dissemination. Data is available online nationwide substantially before paper copies can be distributed. Benefits accrue to the users in terms of increased productivity and timely access to information as well as through reduced storage costs.

CD-ROM and other electronic formats are continuing to replace paper publications and are being used to disseminate information never published in paper formats. Certain publications that would have been prohibitively expensive to produce in paper are being published as CD-ROMs. Given the cost advantage per volume of data afforded by CD-ROM over traditional paper alternatives, efficiency in information dissemination is greatly increased by the growing use of CD-ROM.

Microfiche publications presently account for about 60 percent of depository library distributions. The use of electronic dissemination will begin to replace microfiche in FY 1996. In the early years of implementation, the savings will be minimal, if any. Much of the potential savings as compared with paper copies, have already been realized through the use of microfiche.

In the longer term, significant savings may be possible, even for publications presently distributed only in microfiche format, as the government moves toward implementation of Standard Generalized Markup Language (SGML) format. Creation of databases in SGML format will facilitate the storage, search, and retrieval of data. SGML will allow microfiche formats as well as paper to be replaced with online full text that can be accessed just when needed. These trends, which are driven by the pace of technology, should eventually result in reduced dissemination costs and increased services.

## LIST OF EXHIBITS

- Exhibit A: Legislative History of Public Law 103-40
- Exhibit B: Current Equipment Configuration for the *GPO Access* Service
- Exhibit C: *GPO Access Now Free!* (Press Release, December 1, 1995)
- Exhibit D: List of Databases Available Online Via *GPO Access* as of December 1, 1995
- Exhibit E: *Federal Register* Page with Instructions for Free Online Access;  
ACFR Resolution Supporting Free Public Access
- Exhibit F: *Congressional Record* Page with Instructions for Free Online Access
- Exhibit G: Sample Screens from the GPO World Wide Web Site
- Exhibit H: 1994 Federal Technology Leadership Award (Press Release, November 18, 1994);  
1995 James Madison Award (Press Release, March 15, 1995)
- Exhibit I: Federal Depository Libraries Sponsoring *GPO Access* Gateways

**Exhibit A:**

**Legislative History of Public Law 103-40**

**Legislative History of Public Law 103-40  
[S. 564] June 8, 1993, 107 Stat. 112, 44 USC § 4101-**

**Government Printing Office  
Electronic Information Access Enhancement Act of 1993**

**Legislative History citations:**

**103d Congress**

- S. 564 Government Printing Office Electronic Information Access Enhancement Act of 1993**  
March 11, 1993, Congressional Record, p. S2781-, introductory statement by Mr. Ford  
March 18, 1993, Senate Report 103-27, Committee on Rules and Administration  
March 22, 1993, Congressional Record, p. S3383-, considered and passed Senate  
May 25, 1993, House Report 103-108, Committee on House Administration  
May 25, 1993, Congressional Record, p. H2771-, considered and passed House  
June 8, 1993, Weekly Compilation of Presidential Documents, vol. 29, p. 1043, President's  
Statement on Signing

**Parallel bill:**

- H.R. 1328 Government Printing Office Electronic Information Access Enhancement Act of 1993**  
March 11, 1993, Congressional Record, p. H1231, introduced by Rep. Rose  
April 1, 1993, House Report 103-51, Committee on House Administration

**Precursor bills:**

**102d Congress**

- H.R. 5983 Government Printing Office Electronic Information Access Enhancement Act of 1992**  
September 22, 1992, Congressional Record, p. H8965, introduced by Rep. Rose; p. E2737, statement  
September 29, 1992, House Report 102-933, Committee on House Administration  
September 29, 1992, Congressional Record, p. H9683, passed in House; received in Senate, referred  
to Committee on Rules
- S. 2813 GPO Gateway to Government Act of 1992**  
June 4, 1992, Congressional Record, p. S7599, introduced by Sen. Gore, statement  
July 23, 1992, Joint Hearing on S. 2813 and H.R. 2772, Senate Committee on Rules and Committee  
on House Administration
- H.R. 2772 GPO Wide Information Network for Online Act of 1991 ("WINDO")**  
June 26, 1991, Congressional Record, introduced by Rep. Rose (37 cosponsors)  
April 8, 1992, Congressional Record, p. H2465, statement by Mr. Owens on National Library Week,  
discussing WINDO bill and inserting American Library Association Fact Sheet  
July 23, 1992, Joint Hearing on H.R. 2772 and S. 2813, Committee on House Administration and  
Senate Committee on Rules



## **101st Congress**

### **H.R. 3849 Government Printing Office Improvement Act of 1990**

January 24, 1990, Congressional Record, p. E35, statement on introduction by Jim Bates,  
January 23, 1990

March 7-8, 1990, Hearings on H.R. 3849, Subcommittee on Procurement and Printing, Committee  
on House Administration

### **Other Background:**

Hearing, Joint Committee on Printing, New Technology and the Government Printing Office, S. Hrg. 102-114,  
June 19, July 24, 1991

Hearing, Joint Committee on Printing, Government Information as a Public Asset, S. Hrg. 102-114, April 24,  
1991

Hearings, Subcommittee on Procurement and Printing, Committee on House Administration, "Title 44 U.S.C.  
Review", May 23-24, June 28-29, 1989

Informing the Nation: Federal Information Dissemination in an Electronic Age. United States Congress, Office  
of Technology Assessment, October 1988

Provision of Federal Government Publications in Electronic Format to Depository Libraries. Report of the Ad  
Hoc Committee on Depository Library Access to Federal Automated Data Bases to the Joint Committee  
on Printing, S. Prt. 98-260, December 1984

Legislative Branch Appropriations Hearings, Part 2, testimony, various years

**Exhibit B:**

**Current Equipment Configuration for the *GPO Access Service***

# Current Equipment Configuration for the GPO Access Service

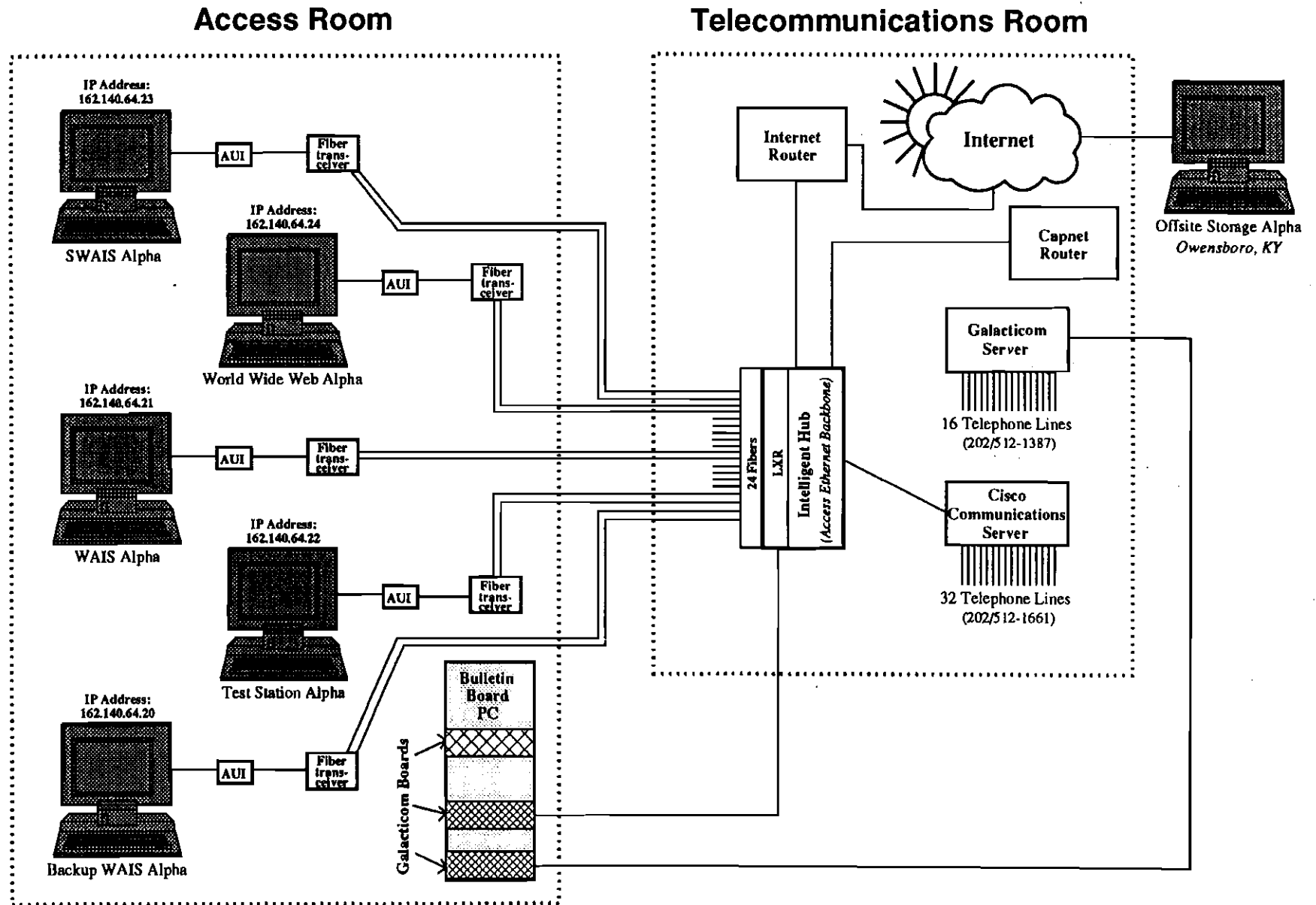

**Exhibit C:**

***GPO Access Now Free!***  
**(Press Release, December 1, 1995)**

# News Release



UNITED  
STATES  
GOVERNMENT  
PRINTING  
OFFICE

For Release :IMMEDIATE  
December 1, 1995

Contact: 202-512-1991  
No. 95-33

## **GPO ACCESS NOW FREE! GOVERNMENT INFORMATION AVAILABLE TO INTERNET/DIAL-IN USERS**

The U.S. Government Printing Office (GPO) announces free use of its award-winning GPO Access online service beginning December 1, 1995. All Internet and dial-in users can now receive electronically, at no charge, the Congressional Record, Federal Register, congressional bills, and a growing list of important government documents on the same day of publication.

"We believe the public should have timely access to vital information about the activities of their government without charge," says head of the GPO, Public Printer Michael F. DiMario. "This service is made possible through the congressional funding of the Federal Depository Library Program at a time when more and more citizens are receiving their information by computer."

The GPO Access service was created by an Act of Congress in 1993 and went online in June 1994. The service earned the 1994 Federal Technology Leadership Award and a 1995 James Madison Award sponsored by the Coalition on Government Information.

Until now, GPO Access has been free only to users on-site in some 600 of the Nation's nearly 1,400 Federal Depository Libraries and to remote users connecting through over 20 depository library "gateways." It was available to others on a subscription basis for a low fee. Under the new program, the subscription fee has been dropped and refunds of unused portions will be sent to current subscribers.

DiMario emphasizes that depository libraries will continue as an essential link between GPO Access and the public. "Citizens lacking either computers or computer skills can visit a local depository for assistance," he explains.

The new system now gives equal and free access to those utilizing a depository library and to those who are linked already by dial-up or Internet connections to electronic information. As the Federal Depository Library Program becomes more electronic in nature, additional databases will be available through GPO Access. Since its creation in 1994, the number of databases offered online via GPO Access has increased from seven to more than two dozen.

Government databases can be reached via the Internet or by dial-in through a modem.

**Internet users can access the databases with a World Wide Web browser through the Superintendent of Documents' home page at: [http://www.access.gpo.gov/su\\_docs/](http://www.access.gpo.gov/su_docs/) or with WAIS client software.**

**Internet users can also telnet to [swais.access.gpo.gov](http://swais.access.gpo.gov); then login as guest.**

**Dial-in users should use a modem to call 202-512-1661; type swais and then login as guest.**

In more than 20 States, users with modems can connect to GPO Access through depository library "gateways" with a local phone call. Listings of depository libraries and "gateways" can be found on the Superintendent of Documents' home page.

General information on accessing these databases is available by:

**e-mail - [help@eids05.eids.gpo.gov](mailto:help@eids05.eids.gpo.gov)**

**phone - 202-512-1530**

**fax - 202-512-1262**

Questions about the GPO Access service can also be directed to a nearby Federal Depository Library. At least one such library is located in each congressional district.

**Exhibit D:**

**List of Databases Online Via *GPO Access*  
As of December 1, 1995**

## **List of Databases Online Via *GPO Access* As of December 1, 1995**

The *GPO Access* databases required by Public Law 103-40 are the *Congressional Record* and the *Federal Register*, which includes the Unified Agenda. As of December 1, 1995, the following additional databases were available online via *GPO Access*:

### **Congressional Bills Online via *GPO Access***

The Congressional Bills databases contain all published versions of Congressional Bills from the 103d Congress (1993-1994) and 104th Congress (1995-1996). All bills are available as both ASCII text and Adobe Acrobat Portable Document Format (PDF) files.

### **Congressional Documents Online via *GPO Access***

The Congressional Documents database contains a selection of House, Senate and Treaty Documents for the 104th Congress (1995-1996). Documents are available as both ASCII text and Adobe Acrobat Portable Document Format (PDF) files.

### **Congressional Directory Online via *GPO Access***

The Congressional Directory database contains the full text of Congressional Directory, 1995-1996 (Senate Publication 104-14, revised). Documents are available as both ASCII and Adobe Acrobat Portable Document Format (PDF) files.

### **Congressional Reports Online via *GPO Access***

The Congressional Reports database contains all published House, Senate and Executive Reports for the 104th Congress (1995-1996). Reports are available as both ASCII text and Adobe Acrobat Portable Document Format (PDF) files.

### **Economic Indicators Online via *GPO Access***

The Economic Indicators database contains Economic Indicators for the 104th Congress from April 1995 forward. Documents are available as both ASCII text and Adobe Acrobat Portable Document Format (PDF) files.

### **Congressional Record Index Online via *GPO Access***

The Congressional Record Index databases contain the cumulative text of the Index for the 102d Congress, Second Session (Volume 138, 1992), the 103d Congress (Volumes 139-140, 1993-1994) and the 104th Congress, First Session (Volume 141, 1995). Index entries are available as ASCII text files.

### **GAO Reports Online via *GPO Access***

The GAO Reports database contains all published reports for FY 1995, except correspondence and reports that are restricted or classified. Reports are available as both ASCII text and Adobe Acrobat Portable Document Format (PDF) files.

### **Government Manual Online via *GPO Access***

The Government Manual database contains the text of the Government Manual, 1995-1996. Documents are available as both ASCII text and Adobe Acrobat Portable Document Format (PDF) files.

### **History of Bills Online via *GPO Access***

The History of Bills and Resolutions is a section of the Congressional Record Index. The databases contain the cumulative text of the History of Bills for the 103d Congress, Second Session (Volume 140, 1994) and the 104th Congress, First Session (Volume 141, 1995). Entries are available as ASCII text files.



**House Calendar Online via GPO Access**

The House Calendar database contain the current issue of the House Calendar for the 104th Congress (1995-1996). Documents are available as both ASCII text and Adobe Acrobat Portable Document Format (PDF) files.

**Public Laws Online via GPO Access**

The Public Laws databases contains all laws enacted during the 104th Congress (1195-1996). Individual laws are available as both ASCII text and Adobe Acrobat Portable Document Format (PDF) files.

**Senate Calendar Online via GPO Access**

The Senate Calendar database contains the current issue of the Senate Calendar for the 104th Congress (1995-1996). Documents are available as both ASCII text and Adobe Acrobat Portable Document Format (PDF) files.

**United States Code Online via GPO Access**

The United States Code database contains the general and permanent laws of the United States in effect as of January, 1994 or January, 1995 (depending on the Title). Code sections are available as ASCII text files. Graphics are provided as separate scanned-image TIFF files. Notification of a change to a section of the United States Code will usually occur within five business days of the enactment of the law; the text of a revision is incorporated as the annual bound volumes are published.

**Exhibit E:**

***Federal Register* Page with Instructions for Free Online Access;  
ACFR Resolution Supporting Free Public Access**



FEDERAL REGISTER Published daily, Monday through Friday, (not published on Saturdays, Sundays, or on official holidays), by the Office of the Federal Register, National Archives and Records Administration, Washington, DC 20408, under the Federal Register Act (49 Stat. 500, as amended; 44 U.S.C. Ch. 15) and the regulations of the Administrative Committee of the Federal Register (1 CFR Ch. I). Distribution is made only by the Superintendent of Documents, U.S. Government Printing Office, Washington, DC 20402.

The Federal Register provides a uniform system for making available to the public regulations and legal notices issued by Federal agencies. These include Presidential proclamations and Executive Orders and Federal agency documents having general applicability and legal effect, documents required to be published by act of Congress and other Federal agency documents of public interest. Documents are on file for public inspection in the Office of the Federal Register the day before they are published, unless earlier filing is requested by the issuing agency.

The seal of the National Archives and Records Administration authenticates this issue of the Federal Register as the official serial publication established under the Federal Register Act. 44 U.S.C. 1507 provides that the contents of the Federal Register shall be judicially noticed.

The Federal Register is published in paper, 24x microfiche and as an online database through *GPO Access*, a service of the U.S. Government Printing Office. The online database is updated by 6 a.m. each day the Federal Register is published. The database includes both text and graphics from Volume 59, Number 1 (January 2, 1994) forward. Free public access is available on a Wide Area Information Server (WAIS) through the Internet and via asynchronous dial-in. Internet users can access the database by using the World Wide Web; the Superintendent of Documents home page address is [http://www.access.gpo.gov/su\\_docs/](http://www.access.gpo.gov/su_docs/), by using local WAIS client software, or by telnet to [swais.access.gpo.gov](mailto:swais.access.gpo.gov), then login as guest, (no password required). Dial-in users should use communications software and modem to call (202) 512-1661; type swais, then login as guest (no password required). For general information about *GPO Access*, contact the *GPO Access* User Support Team by sending Internet e-mail to [help@eids05.eids.gpo.gov](mailto:help@eids05.eids.gpo.gov); by faxing to (202) 512-1262; or by calling (202) 512-1530 between 7 a.m. and 5 p.m. Eastern time, Monday-Friday, except for Federal holidays.

The annual subscription price for the Federal Register paper edition is \$494, or \$544 for a combined Federal Register, Federal Register Index and List of CFR Sections Affected (LSA) subscription; the microfiche edition of the Federal Register including the Federal Register Index and LSA is \$433. Six month subscriptions are available for one-half the annual rate. The charge for individual copies in paper form is \$8.00 for each issue, or \$8.00 for each group of pages as actually bound; or \$1.50 for each issue in microfiche form. All prices include regular domestic postage and handling. International customers please add 25% for foreign handling. Remit check or money order, made payable to the Superintendent of Documents, or charge to your GPO Deposit Account, VISA or MasterCard. Mail to: New Orders, Superintendent of Documents, P.O. Box 371954, Pittsburgh, PA 15250-7954.

There are no restrictions on the republication of material appearing in the Federal Register.

How To Cite This Publication: Use the volume number and the page number. Example: 60 FR 12345.

**SUBSCRIPTIONS AND COPIES**

**PUBLIC**

<b>Subscriptions:</b>	
Paper or fiche	202-512-1800
Assistance with public subscriptions	512-1806
<b>General online information</b>	
	202-512-1530
<b>Single copies/back copies:</b>	
Paper or fiche	512-1800
Assistance with public single copies	512-1803

**FEDERAL AGENCIES**

<b>Subscriptions:</b>	
Paper or fiche	523-5243
Assistance with Federal agency subscriptions	523-5243
For other telephone numbers, see the Reader Aids section at the end of this issue.	

**THE FEDERAL REGISTER**

**WHAT IT IS AND HOW TO USE IT**

- FOR:** Any person who uses the Federal Register and Code of Federal Regulations.
- WHO:** Sponsored by the Office of the Federal Register.
- WHAT:** Free public briefings (approximately 3 hours) to present:
  1. The regulatory process, with a focus on the Federal Register system and the public's role in the development of regulations.
  2. The relationship between the Federal Register and Code of Federal Regulations.
  3. The important elements of typical Federal Register documents.
  4. An introduction to the finding aids of the FR/CFR system.
- WHY:** To provide the public with access to information necessary to research Federal agency regulations which directly affect them. There will be no discussion of specific agency regulations.

**WASHINGTON, DC**

- WHEN:** December 5 at 9:00 am
- WHERE:** Office of the Federal Register Conference Room, 800 North Capitol Street, NW., Washington, DC (3 blocks north of Union Station Metro)
- RESERVATIONS:** 202-523-4538

**LONG BEACH, CA**

- WHEN:** December 12, 1995 at 9:00 am
- WHERE:** Glenn M. Anderson Federal Building, Conference Room—Room 3470, 501 West Ocean Boulevard, Long Beach, CA 90802
- RESERVATIONS:** 310-980-3447

**SEATTLE, WA**

- [Two Sessions]
- WHEN:** December 13, 1995 at 9:00 am and 1:00 pm
- WHERE:** National Archives—Pacific Northwest Region, Conference Room, 6125 Sand Point Way, NE., Seattle, WA 98115
- RESERVATIONS:** 206-526-6507



## **ACFR Resolution Supporting Free Public Access**

The Administrative Committee of the Federal Register (ACFR) met on December 12, 1995, at the National Archives, and passed the following resolution:

Resolved,

That the Administrative Committee of the Federal Register supports the availability of online access to electronic databases of the *Federal Register*, the *Code of Federal Regulations* and other publications authorized by the ACFR at no charge to the user; and that to improve Governmental efficiency, recipients of official copies of these publications should review their requirements for reductions in the number of paper copies distributed as online access is made available.

**Exhibit F:**

***Congressional Record* Page With Instructions for Free Online Access**

Next Meeting of the SENATE  
9:30 a.m., Tuesday, December 5

Senate Chamber

Program for Tuesday: Senate will consider the conference report on H.R. 1058, Securities Litigation.

(Senate will recess from 12:30 p.m. until 2:15 p.m. for respective party conferences.)

Next Meeting of the HOUSE OF REPRESENTATIVES  
12:30 p.m., Tuesday, December 5

House Chamber

Program for Tuesday: Consideration of the following 11 Suspensions:

1. H.R. 826, Big Thicket National Preserve Land Exchange;
  2. H.R. 2336, Amending the Doug Barnard, Jr. 1996 Atlanta Centennial Olympic Games Commemorative Coin Act;
  3. H.R. 2614, Commemorative Coin Authorization and Reform Act of 1995;
  4. H.R. 308, Hopewell Township Investment Act of 1995;
  5. H.R. 255, Designating the James Lawrence King Federal Justice Building;
  6. H.R. 395, Designating the Bruce R. Thompson U.S. Courthouse and Federal Building;
  7. H.R. 653, Designating the Thurgood Marshall U.S. Courthouse;
  8. H.R. 840, Designating the Walter B. Jones Federal Building and U.S. Courthouse;
  9. H.R. 869, Designating the Thomas D. Lambros Federal Building and U.S. Courthouse;
  10. H.R. 965, Designating the Romano L. Mazzoli Federal Building;
  11. H.R. 1804, Designating the Judge Isaac C. Parker Federal Building; and
- Consideration of H.R. 1350, Maritime Security Act of 1995 (open rule).

Extensions of Remarks, as inserted in this issue

HOUSE

Gunderson, Steve, Wis., E2280  
Heineman, Fred, N.C., E2279  
Pelosi, Nancy, Calif., E2279  
Solomon, Gerald B.H., N.Y., E2279  
Waxman, Henry A., Calif., E2280



# Congressional Record

The public proceedings of each House of Congress, as reported by the Official Reporters thereof, are printed pursuant to directions of the Joint Committee on Printing as authorized by appropriate provisions of Title 44, United States Code, and published for each day that one or both Houses are in session, excepting very infrequent instances when two or more unusually small consecutive issues are printed at one time. ¶Public access to the Congressional Record is available online through GPO Access, a service of the Government Printing Office, free of charge to the user. The online database is updated each day the Congressional Record is published. The database includes both text and graphics from the beginning of the 103d Congress, 2d session (January 1994) forward. It is available on the Wide Area Information Server (WAIS) through the Internet and via asynchronous dial-in. Internet users can access the database by using the World Wide Web; the Superintendent of Documents home page address is [http://www.access.gpo.gov/su\\_docs](http://www.access.gpo.gov/su_docs), by using local WAIS client software or by telnet to [swais.access.gpo.gov](mailto:swais.access.gpo.gov), then login as guest (no password required). Dial-in users should use communications software and modem to call (202) 512-1661; type swais, then login as guest (no password required). For general information about GPO Access, contact the GPO Access User Support Team by sending Internet e-mail to [help@eids05.eids.gpo.gov](mailto:help@eids05.eids.gpo.gov), or a fax to (202) 512-1262; or by calling (202) 512-1530 between 7 a.m. and 5 p.m. Eastern time, Monday through Friday, except for Federal holidays. ¶The Congressional Record paper and 24x microfiche will be furnished by mail to subscribers, free of postage, at the following prices: paper edition, \$112.50 for six months, \$225 per year, or purchased for \$1.50 per issue, payable in advance; microfiche edition, \$118 per year, or purchased for \$1.50 per issue payable in advance. The semi-monthly Congressional Record Index may be purchased for the same per issue prices. Remit check or money order, made payable to the Superintendent of Documents, directly to the Government Printing Office, Washington, D.C. 20402. ¶Following each session of Congress, the daily Congressional Record is revised, printed, permanently bound and sold by the Superintendent of Documents in individual parts or by sets. ¶With the exception of copyrighted articles, there are no restrictions on the republication of material from the Congressional Record.

**Exhibit G:**

**Sample Screens from the GPO World Wide Web Site**

## Sample Screens from the GPO World Wide Web Site

List of sample screens from the GPO World Wide Web site:

**GPO Home Page** (<http://www.access.gpo.gov>)

**Superintendent of Documents' Home Page** (/su\_docs/)

**Superintendent of Documents' Services to the Public** (/su\_docs/amiss001.html)

**Electronic Information: Online, On-Demand and Locator Services** (/su\_docs/aces/aaces001.html)

**Connect to Databases Online via GPO Access** (/su\_docs/aces/aaces002.html)

**1995 Federal Register** (/su\_docs/aces/aces140.html)

**1995 Congressional Record** (/su\_docs/aces/aces150.html)

**Connect to GPO Access ... Through a Federal Depository Library Gateway** (/su\_docs/aces/aaces004.html)

**GPO Access Federal Locator Services** (/su\_docs/aces/aces700.html)

**Pathway to Government Information** (/su\_docs/aces/aces760.html)

**GPO Access On-Demand Delivery Services** (/su\_docs/aces/aaces800.html)

**Information Available for Free Public Use in Federal Depository Libraries** (/su\_docs/dpos/adpos001.html)

**Locate Federal Depository Libraries by State or Area Code** (/su\_docs/dpos/adpos003.html)

**Identify Information Available in Federal Depository Libraries** (/su\_docs/dpos/adpos400.html)

**Identify Information Available in Federal Depository Libraries** (/su\_docs/dpos/adpos430.html)

**Monthly Catalog Search Results** (Generated in Response to Query)

**Locate Federal Depository Libraries by State or Area Code** (Generated in Response to Query)

**Information for Sale by the Superintendent of Documents** (/su\_docs/sale/sale001.html)

**Location of U.S. Government Bookstores by City** (/su\_docs/sale/abkst001.html)

**U.S. Government Bookstore Denver, Colorado** (/su\_docs/sale/abkst009.html)

The address for the GPO World Wide Web site is <http://www.access.gpo.gov>; this retrieves the GPO Home Page. Specific screens, other than search results, can be addressed directly by adding the phrase in parentheses after each page listed above, or by following the menu choices.



# UNITED STATES GOVERNMENT PRINTING OFFICE

*Keeping  
America  
Informed*

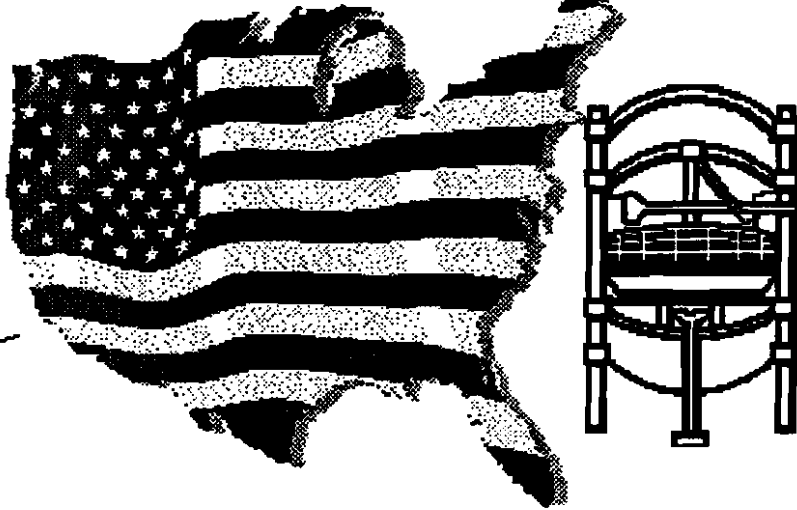

---

Welcome to the U.S. Government Printing Office Home Page

## About the Government Printing Office

Access to Federal Government Publications  
Superintendent of Documents

GPO Access: On-line, On-Demand & Locator Services  
Information Available for Free Public use in Federal Depository Libraries  
Information for Sale

Congress of the United States  
Department of Interior Office of Inspector General   
General Accounting Office  
National Archives and Records Administration's Office of the Federal Register  
Office of Management and Budget  
Office of Technology Assessment  
State Department

## Services Available to Federal Agencies

Printing and Binding (Under Construction)  **FUTURE**  
Electronic Prepress and Document Creation  
Institute for Federal Printing and Publishing

## Business and Contracting Opportunities

Printing Procurement  
Materials Management Service

## Navigation Aids

---

Questions or comments regarding this service? Contact [wwwadmin@www.access.gpo.gov](mailto:wwwadmin@www.access.gpo.gov).

Keeping  
America  
Informed



---

---

**Welcome to the Superintendent of Documents' Home Page on the U.S. Government Printing  
Office Web Site**

**The Pathway to Federal Government Information**



**Electronic Information: Online, On-Demand & Locator Services**

Search the full text of the *Federal Register*, *Congressional Record*, *Congressional Bills* and other Federal government information online via *GPO Access*. Locate and download electronic information from numerous Federal agencies.



**Information Available for Free Public Use in Federal Depository Libraries**

Identify Federal government information available at or through any of 1,400 Federal Depository Libraries located throughout the country.

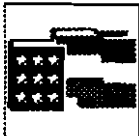

**Information for Sale by the Superintendent of Documents**

Purchase books, maps, posters, periodicals and electronic information products from numerous Federal agencies. Find the nearest U.S. Government Bookstore or connect to the electronic Consumer Information Catalog.



**Superintendent of Documents' Services to the Public**

The Superintendent of Documents keeps Americans informed about the activities of their Government by providing free or low-cost access to information published by the U.S. Congress, Federal agencies and the Federal courts.

---

---

Questions or comments regarding this service? Contact the *GPO Access* User Support Team  
by Internet e-mail at [help@eids05.eids.gpo.gov](mailto:help@eids05.eids.gpo.gov), by telephone at 202-512-1530; or by fax at 202-512-1262.



Keeping  
America  
Informed



---

---

Superintendent of Documents' Services to the Public

The Superintendent of Documents keeps Americans informed about the activities of their Government by providing free or low-cost access to information published by U.S. Congress, Federal agencies and the Federal courts.

This mission is achieved through four major programs:

▶ **Online Information Via GPO Access Services**

The *Federal Register*, *Congressional Record*, *Congressional Bills* and other Federal government information are available online via *GPO Access*, a service of the U.S. Government Printing Office.

▶ **The Federal Depository Library Program**

You may have free access to Government information by visiting one of the approximately 1,400 Federal Depository Libraries located throughout the country. Online information is available on site and through Depository Library Gateways.

▶ **The Documents Sales Program**

You may purchase books, periodicals and electronic information products from the Documents Sales Service by mail, phone or fax, or by visiting one of 24 U.S. Government Bookstores nationwide.

▶ **The Consumer Information Program**

You may order free or low-price consumer publications from the GPO's Public Documents Distribution Center in Pueblo, CO. Information is provided by the Consumer Information Center of the General Services Administration.

---

---

Questions or comments about this service? Contact [help@eids05.eids.gpo.gov](mailto:help@eids05.eids.gpo.gov).





# ***GPO Access*** **Keeping America Informed Electronically**

---

---

## **Electronic Information: Online, On-Demand and Locator Services Through *GPO Access***

The *Federal Register*, *Congressional Record*, *Congressional Bills* and other Federal government information are available online via *GPO Access*, a service of the U.S. Government Printing Office (GPO). Public access is available through the Federal Depository Library, or directly from GPO.

- [!\[\]\(cdf2842d82858164c68c92720a337fb9\_img.jpg\) Connection to the Online Databases](#)
- [!\[\]\(3973dad7f2f3eafb2c144deb79d5c822\_img.jpg\) Description of the Online Databases](#)
- [!\[\]\(78688513da7a924039ac16e546d7bf8b\_img.jpg\) Access methods for Online Databases](#)
- [!\[\]\(508a1136d49b79584e89f03b586dfa9e\_img.jpg\) Free Public Access Through a Federal Depository Library Gateway](#)
- [!\[\]\(857a1917d2813fe7f9df1c2d3a9286e1\_img.jpg\) Free Public Access On Site at a Federal Depository Library](#)
- [!\[\]\(6c12030baa33d7760a5e4c7c9e008d93\_img.jpg\) \*GPO Access\* Federal Locator Services](#)
- [!\[\]\(38d8e1eba6db628aa66110ffbf829043\_img.jpg\) \*GPO Access\* On-Demand Delivery Services](#)

---

---

Questions or comments about this service? Contact [help@eids05.eids.gpo.gov](mailto:help@eids05.eids.gpo.gov).



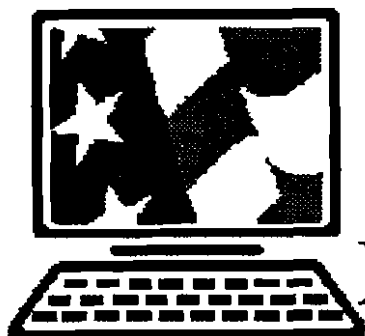

# GPO Access

## Keeping America Informed Electronically

---

---

### Connect to Databases Online via *GPO Access*

Select databases and enter searches below. Access is also available through [Federal Depository Library Gateways](#) or on-site at a [Federal Depository Library](#). [Helpful Hints](#) provide instructions for searching the databases.

Advanced searches are currently supported for three databases: [1995 Federal Register](#), [1995 Congressional Record](#), and the [GAO Reports](#) database. Fields in these databases make it possible to perform more specific (advanced) searches, such as limiting results by date or by section of the *Register* or *Record*, but are specific to the individual databases.

For simple searches select one **OR MORE** databases from the list below:

Congressional Record Index (1992)
Congressional Record Index (1993)
Congressional Record Index (1994)
Congressional Record Index (1995)
Congressional Reports, 104th Congress
Economic Indicators, 104th Congress
Federal Register, Volume 59 (1994)
Federal Register, Volume 60 (1995)

Enter search terms in the space below. Phrases must be in quotation marks (" "). The operators ADJ (adjacent), AND, OR and NOT can be used, but must be capital letters. For example: "environmental protection agency" AND superfund. Word roots can be searched using an asterisk ( \* ) following the word stem. For example: legislat\* will retrieve both legislation and legislative. [Additional instructions and examples](#).

Maximum Records Returned:  Default is 40. Maximum is 200.

Search Terms:

SUBMIT

CLEAR

---

---

Questions or comments regarding this service? Contact the *GPO Access* User Support Team  
by Internet e-mail at [help@eids05.eids.gpo.gov](mailto:help@eids05.eids.gpo.gov), by telephone at 202-512-1530; or by fax at 202-512-1262.



# Federal Register Online via GPO Access

## Database for the 1995 Federal Register (Volume 60)

The *Federal Register* is the official publication for Presidential Documents and Executive Orders as well as Notices, Rules and Proposed Rules from Federal Agencies and Organizations. [Helpful Hints](#) provide instructions for searching the database.

Enter search terms in the space below. Phrases must be in quotation marks ( " "). The operators ADJ (adjacent), AND, OR and NOT can be used, but must be in capital letters. For example: "environmental protection agency" AND superfund. The page cited as 60 FR 12345 can be retrieved using the search "page 12345". CFR parts should also be searched as phrases; for example: "40 CFR part 55". Word roots can be searched using an asterisk ( \* ) following the word stem. For example: regulat\* will retrieve both regulation and regulate. [Additional instructions and examples.](#)

To search the [Unified Agenda](#), return to the [list of databases](#) available for simple searches. **Maximum Records Returned:**

Default is 40. Maximum is 200.

**Federal Register Sections** (Select one or more):

- |                          |  |                          |  |
|--------------------------|--|--------------------------|--|
| <input type="checkbox"/> | <a href="#">Contents and Preliminary Pages</a> | <input type="checkbox"/> | <a href="#">Presidential Documents</a> |
| <input type="checkbox"/> | <a href="#">Final Rules and Regulations</a>    | <input type="checkbox"/> | <a href="#">Sunshine Act Meetings</a>  |
| <input type="checkbox"/> | <a href="#">Proposed Rules</a>                 | <input type="checkbox"/> | <a href="#">Reader Aids</a>            |
| <input type="checkbox"/> | <a href="#">Notices</a>                        | <input type="checkbox"/> | <a href="#">Corrections</a>            |

Search Terms:

Issue Date (Enter either a range of dates or a specific date in the format mm/dd/yy):

Date Range: From

to

OR

ON  BEFORE  AFTER

SUBMIT

CLEAR

Questions or comments regarding this service? Contact the *GPO Access* User Support Team  
by Internet e-mail at [help@eids05.eids.gpo.gov](mailto:help@eids05.eids.gpo.gov), by telephone at 202-512-1530; or by fax at 202-512-1262.



# Congressional Record Online via GPO Access

## 1995 Congressional Record (Volume 141)

The *Congressional Record* is the official record of the proceedings and debates of the United States Congress. It is published daily when Congress is in session. [Helpful Hints](#) provide instructions for searching the *Congressional Record* database.

Enter search terms in the space below. Phrases must be in quotation marks (" "). The operators ADJ (adjacent), AND, OR and NOT can be used, but must be in capital letters. For example: "environmental protection agency" AND superfund. Specific page numbers can be retrieved using the search "page h1234" for House pages or "page s1234" for Senate pages. Bill numbers should also be searched as phrases; for example: "H.R.1234" for a House bill or "S.123" for a Senate bill. Word roots can be searched using an asterisk ( \* ) following the word stem. For example: legislat\* will retrieve both legislation and legislative. [Additional instructions and examples.](#)

Return to the [list of databases](#) available for simple searches. Maximum Records Returned:  Default is 40. Maximum is 200.

**Congressional Record Sections** (Select one or more):

- |                          |                                |                          |                                       |
|--------------------------|--------------------------------|--------------------------|---------------------------------------|
| <input type="checkbox"/> | <a href="#">Daily Digest</a>   | <input type="checkbox"/> | <a href="#">Extensions of Remarks</a> |
| <input type="checkbox"/> | <a href="#">House Section</a>  | <input type="checkbox"/> | <a href="#">Lobby List</a>            |
| <input type="checkbox"/> | <a href="#">Senate Section</a> |                          |                                       |

Search Terms:

**Issue Date** (Enter either a range of dates or a specific date in the format mm/dd/yy):

Date Range: From  to

OR

ON  BEFORE  AFTER

SUBMIT

CLEAR

Questions or comments regarding this service? Contact the *GPO Access* User Support Team  
by Internet e-mail at [help@eids05.eids.gpo.gov](mailto:help@eids05.eids.gpo.gov), by telephone at 202-512-1530; or by fax at 202-512-1262.



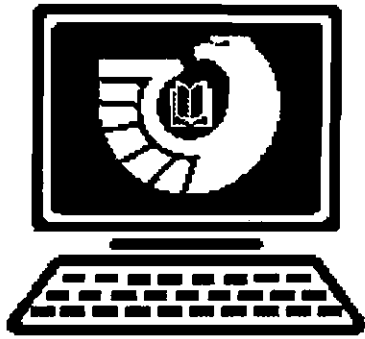

# Federal Depository Library GATEWAYS

---

---

## Connect to *GPO Access* Online Databases Through A Federal Depository Library Gateway

GPO Access databases are also accessible directly from GPO or on-site at a Federal Depository Library

▶ [Auburn University State Library \(WWW\)](#)

[Instructions](#) for using the Auburn University Library Gateway Service

▶ [North Carolina State University Libraries Gateway](#)

[Instructions](#) for using the North Carolina State University Libraries Gateway

▶ [Oklahoma State University \(WWW\)](#)

[Instructions](#) for using the (Oklahoma State University) Oklahoma Gateway Service

▶ [Purdue University \(WWW\)](#)

[Instructions](#) for using the Purdue University Gateway Service

▶ [Renne Library, Montana State University-Bozeman](#)

[Instructions](#) for using the Renne Library, Montana State University-Bozeman

▶ [SAILOR-Maryland's Online Public Information Network \(WWW\)](#)

[Instructions](#) for using SAILOR - Maryland's Online Public Information Network

▶ [University of California \(WWW\)](#)

[Instructions](#) for using the University of California Gateway Service

▶ [University of Tennessee, Knoxville \(WWW\)](#)

[Instructions](#) for using the University of Tennessee, Knoxville Libraries

▶ [University of New Mexico, Zimmerman Library \(WWW\)](#)

[Instructions](#) for using the University of New Mexico, Zimmerman Library Gateway

▶ [University of North Carolina \(Lynx\)](#)

[Instructions](#) for using the University of North Carolina Gateway Service

▶ [WINSLO-Web Information Network, State Library of Ohio \(WWW\)](#)



Instructions for using the WINSLO, Web Information Network, State Library of Ohio

**▣ Gateways Offering SWAIS Access via Telnet and Gopher**

---

---

Questions or comments regarding this service? Contact the **GPO Access User Support Team**  
by Internet e-mail at [help@eids05.eids.gpo.gov](mailto:help@eids05.eids.gpo.gov), by telephone at 202-512-1530; or by fax at 202-512-1262.



Page #AACES004 DECEMBER 19, 1995 ©MDBO



# GPO Access

## Keeping America Informed Electronically

---

---

### **GPO Access Federal Locator Services**

Through its Federal Locator Services GPO offers a Pathway to Government Information, much of which is available to the public without cost. The following Pathway services identify and locate Federal government publications, subscriptions and electronic resources on topics of interest.

- [Information Available for Free Public Use in Federal Depository Libraries](#)
  - [Department of Energy Reports Available for Free Public Use in Federal Depository Libraries](#)
  - [Information for Sale by the Superintendent of Documents](#)
  - [Consumer Information Catalog \(Free and Low Cost Government Publications\)](#)
  - [The Federal Bulletin Board \(Free and Low Cost Government Data On Demand\)](#)
  - [Pathway to Other Government Information \(Including GILS Records\)](#)
- 
- 

**Questions or comments regarding this service? Contact the GPO Access User Support Team**  
by Internet e-mail at [help@eids05.eids.gpo.gov](mailto:help@eids05.eids.gpo.gov), by telephone at 202-512-1530; or by fax at 202-512-1262.



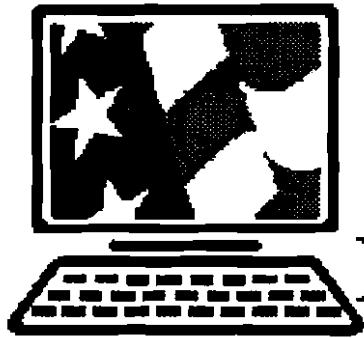

# GPO Access

## Keeping America Informed Electronically

---

---

### Pathway to Government Information

As part of its Federal Locator Services, GPO is identifying, evaluating and linking to Federal World Wide Web and Gopher sites to create a pathway through the maze of government information available on the Internet. At present this service provides information on a small number of sites and covers only three topics: Business, Cancer and Solar Energy. These entries are the initial paving stones along a Pathway that will eventually guide users in searching and discovering government information on a wide variety of topics.

---

Locate Information Resources Described in Government Information Locator Service (GILS) Records by Using a Keyword Search:

[GILS Records](#)

[Privacy Acts](#)

---

Locate Individual Pages on Federal Web Sites by Using a Keyword Search: [Under Development]

[Index of Business Sites](#)

[Index of Cancer Sites](#)

[Index of Solar Energy Sites](#)

---

Review Lists of Federal Web Sites by Topic:

[Topics A-C](#)

[Topics D-Q \[Under Development\]](#)

[Topics R-T](#)

[Topics U-Z \[Under Development\]](#)

---

---

Questions or comments regarding this service? Contact the *GPO Access User Support Team*  
by Internet e-mail at [help@eids05.eids.gpo.gov](mailto:help@eids05.eids.gpo.gov), by telephone at 202-512-1530; or by fax at 202-512-1262.



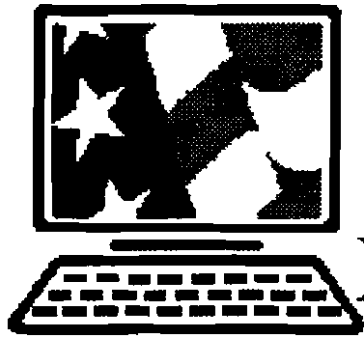

# GPO Access



## Keeping America Informed Electronically

---

---

### GPO Access On-Demand Delivery Services

Files from selected CD-ROM titles are available for viewing and downloading as a demonstration. The CD-ROM titles containing these files are also available for free on site use in Federal Depository Libraries and for sale from the U.S. Government Printing Office (GPO).

- ▶ [The Budget of the United States Government \(FY1996\)](#) 
- ▶ [Department of State Country Studies \(Background Notes\)](#) 
- ▶ [Selected Foreign Affairs Documents from the Department of State](#) 

---

### Washington Watch

The *Federal Register*, *Congressional Record*, *Congressional Bills* and other Federal government information are available online via GPO Access and provide on-demand delivery of the major Federal legislative and regulatory documents on the day of publication. Access is provided through Federal Depository Library Gateways, and on-site at Federal Depository Libraries, Direct Access is also available from GPO.

---

The *Congressional Record* is published daily when Congress is in Session. The *Daily Digest* from the most recent issue is available here on the day of publication. The issue date is always the day before the date of publication.

- ▶ [Daily Digest of the Actions of the U.S. Senate and House of Representatives](#)  87K

also available as [ASCII text](#)  22K

---

The *Federal Register* is published Monday through Friday, except Federal holidays. The Contents from the current issue is available here on the day of publication. The issue date is always the same as the day of publication.

- ▶ [Table of Contents](#)  25K

also available as [ASCII text](#)  16K





# Federal Depository Library Program

---

---

## Information Available for Free Public Use in Federal Depository Libraries

There are nearly 1,400 Federal depository libraries located throughout the United States and its territories, at least one in every Congressional District. All provide free public access to a wide variety of Federal government information, in both print and electronic formats, and have expert staff available to assist users.

### Locate Depository Libraries by State or Area Code

All depository libraries have government information. Most collections are tailored to meet local community needs and interests.

### Locate Regional Depository Libraries by State

Fifty-three regional depository libraries collect and permanently retain all information distributed under the Federal Depository Library Program.

### Locate Electronic Federal Depository Libraries by State or Area Code

Electronic depository libraries provide free public use of the *GPO Access* online services, either through on site computers or via Federal Depository Library Gateways.

### Identify Information Available for Free Public Use in Federal Depository Libraries

Federal government information can be identified by searching the *Monthly Catalog of U.S. Government Publications*. Once publications are identified, a further search may identify depository libraries that receive those publications.

### Identify Department of Energy Reports Available for Free Public Use in Federal Depository Libraries

Energy information can be identified by searching the *DOE Reports Bibliographic Database*. Once publications are identified, a further search may identify depository libraries that receive those publications.

### GPO Access On-Demand Delivery Services

### GPO Access Federal Locator Services

---

---

Questions or comments about this service? Contact [help@eids05.eids.gpo.gov](mailto:help@eids05.eids.gpo.gov).





# Federal Depository Library Program

---

---

## Locate Federal Depository Libraries by State or Area Code

There are approximately 1,400 Federal depository libraries throughout the United States and its territories, at least one in every Congressional District. All provide free public access to a wide variety of Federal government information in both print and electronic formats, and have expert staff available to assist users.

Locate the Federal depository libraries in any state or territory by entering one or more 2-letter U.S. Postal Service codes (state abbreviations):

For a more specific listing, enter one or more 3-digit telephone area codes.

---

---

Questions or comments regarding this service? Contact the *GPO Access User Support Team*  
by Internet e-mail at [help@eids05.eids.gpo.gov](mailto:help@eids05.eids.gpo.gov); by telephone at 202-512-1530; or by fax at 202-512-1262.



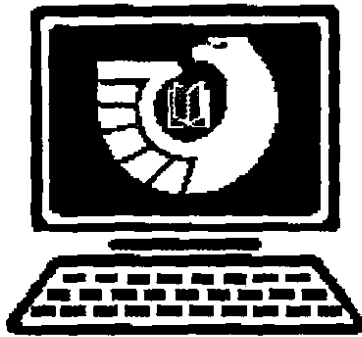

# Electronic Federal Depository Libraries

---

---

## Locate Electronic Federal Depository Libraries by State or Area Code

There are approximately 1,400 Federal depository libraries throughout the United States and its territories, at least one in every Congressional District. All provide free public access to a wide variety of Federal government information in both print and electronic formats, and have expert staff available to assist users. Approximately 500 are certified as electronic Federal depository libraries and provide *GPO Access* online services through on site personal computers and terminals. Some of these electronic libraries provide off-site access through Federal depository library Gateways.

Locate the Federal depository libraries in any state or territory by entering one or more 2-letter U.S. Postal Service codes (state abbreviations):

For a more specific listing, enter one or more 3-digit telephone area codes.

---

---

Questions or comments regarding this service? Contact the *GPO Access* User Support Team by Internet e-mail at [help@eids05.eids.gpo.gov](mailto:help@eids05.eids.gpo.gov), by telephone at 202-512-1530, or by fax at 202-512-1262.



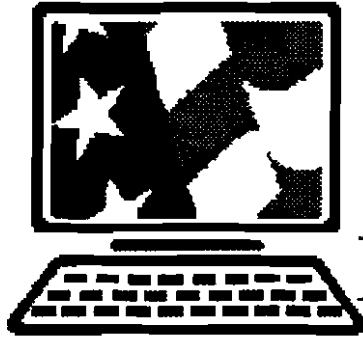

# GPO Access

## Keeping America Informed Electronically

Federal Locator Services

---

---

### Identify Information Available in Federal Depository Libraries

Most information available through the Federal Depository Library Program is cataloged by GPO. These cataloging records are published in the *Monthly Catalog of United States Government Publications* (MOCAT) and made available for online searching as part of the *GPO Access* Federal Locator services. Once a publication is identified, a link is available to locate depository libraries that receive that publication.

The database contains cataloging records published in MOCAT since January 1994 and is updated daily with preliminary cataloging records that will be edited and published in future issues of MOCAT.

Select the fields to be searched. Select only fields that will be used. Selected fields cannot be left blank. Once you have selected the fields, use the SUBMIT button to request a search form. [Additional instructions and examples.](#)

- Search Full Text of MOCAT Records
- Title
- Publication Year
- Superintendent of Documents Class Number
- Depository Item Number
- GPO Sales Stock Number

SUBMIT

CLEAR

---

---

Questions or comments regarding this service? Contact the *GPO Access* User Support Team by Internet e-mail at [help@eids05.eids.gpo.gov](mailto:help@eids05.eids.gpo.gov), by telephone at 202-512-1530; or by fax at 202-512-1262.



Page #ADPOS400 August 11, 1995



## *GPO Access* Federal Locator Services

---

---

### Identify Information Available in Federal Depository Libraries

Enter search terms in the space below. Phrases must be in quotation marks (" "). The operators ADJ (adjacent), AND, OR and NOT can be used, but must be capital letters. For example: "foreign affairs" AND "cd-rom". Word roots can be searched using an asterisk (\*) following the word stem. For example: legislat\* will retrieve both legislation and legislative. [Additional instructions and examples.](#)

Maximum Record Returned:

Default is 40. Maximum is 200.

Search Terms:

Words and phrases entered above will be searched in the full MOCAT record.  
For example, Aviation AND Weather

---

---

Questions or comments regarding this service? Contact the *GPO Access User Support Team*  
by Internet e-mail at [help@eids05.eids.gpo.gov](mailto:help@eids05.eids.gpo.gov); by telephone at 202-512-1530; or by fax at 202-512-1262.



Page #ADPOS430 August 11, 1995

# Monthly Catalog Search Results

The search was:

("foreign affairs" AND "cd-rom")  
Records returned: 3

To locate Federal depository libraries that are likely to have a publication, select [[Locate Libraries](#)]. For the cataloging information for a publication, select [[Full Record](#)].

Publications with a GPO Stock Number may be available for purchase. Contact the nearest [GPO Bookstore](#) to determine if a publication is currently for sale from GPO. (Note the Title and Stock Number)

---

[ 1 ]

U.S. foreign affairs on CD-ROM : USFAC. computer file! : 1993-. Annual. United States. Dept. of State. S 1.142/2:990-93. GPO stock no.: 044-000-02355-5. [[0863-B]].

Rank: 1000 [[Full Record](#)]

[LOCATE LIBRARIES](#)

---

[ 2 ]

US Department of State dispatch /. 1990-. Weekly. United States. Dept. of State. Bureau of Public Affairs. S 1.3/5:(V.NO. NOS.). GPO stock no.: 744-010-00000-4. [[0864]].

Rank: 267 [[Full Record](#)]

[LOCATE LIBRARIES](#)

---

[ 3 ]

Query Report for this Search

Rank: 1 [[Full Record](#)]

[LOCATE LIBRARIES](#)

---

---

Questions or comments regarding this service? Contact the [GPO Access User Support Team](#)  
by Internet e-mail at [help@eids05.eids.gpo.gov](mailto:help@eids05.eids.gpo.gov), by telephone at 202-512-1530; or by fax at 202-512-1262.



Page #adpos430\_results May 31, 1995 □

# GPO Access Federal Locator Services

---

---

## Locate Federal Depository Libraries by State or Area Code

The selected publication is:

U.S. foreign affairs on CD-ROM : USFAC. computer  
file : . 1993-. Annual. United States. Dept.  
of State. S 1.1422:990-93. GPO stock no.: 044-  
000-02355-5.

Item Number:

Locate the Federal depository libraries that are likely to have this publication by entering one or more 2-letter U.S. Postal Service codes (state abbreviations):

<input type="text"/>	<input type="text"/>	<input type="text"/>	<input type="text"/>	<input type="text"/>
----------------------	----------------------	----------------------	----------------------	----------------------

For a more specific listing, enter one or more 3-digit telephone area code(s).

<input type="text"/>	<input type="text"/>	<input type="text"/>
----------------------	----------------------	----------------------

Please contact the libraries to determine their hours of service and confirm the availability of the specific publication.

Browse the entire list of Federal depository libraries that have selected this publication by selecting the ALL button below.

ALL	SUBMIT	CLEAR
-----	--------	-------

---

---

Questions or comments regarding this service? Contact the **GPO Access User Support Team**  
by Internet e-mail at [help@eids05.eids.gpo.gov](mailto:help@eids05.eids.gpo.gov), by telephone at 202-512-1530; or by fax at 202-512-1262.



Page #LOCATE.BLANK August 11, 1995

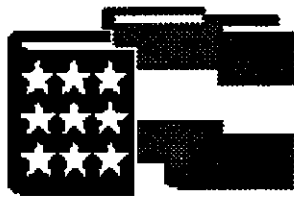

# United States Government INFORMATION

PUBLICATIONS ★ PERIODICALS ★ ELECTRONIC PRODUCTS

---

---

## Information for sale by the Superintendent Of Documents, U.S. Government Printing Office (GPO)

GPO's Superintendent of Documents sells information published by a wide variety of Federal government agencies. Information products may be ordered by mail, telephone or fax, or purchased at one of 24 U.S. Government Bookstores. GPO accepts prepayment by MasterCard, VISA and GPO Deposit Account, as well as by check or money order.

 [Publications](#)

 [Subscriptions](#)

 [CD-ROMs](#)

 [Consumer Information Catalog \(Free and Low Cost Publications\)](#)

 [U.S. Government Bookstores](#)

---

---

Questions or comments about this service? Contact [help@eids05.eids.gpo.gov](mailto:help@eids05.eids.gpo.gov).



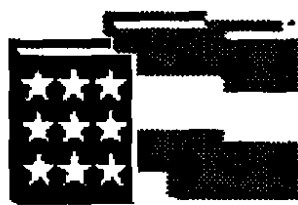

# United States Government BOOKSTORE

## Location of U.S. Government Bookstores by City

Through the Superintendent of Documents, the U.S. Government Printing Office (GPO) operates 24 U.S. Government Bookstores throughout the country. Each bookstore carries a selection of at least 1,500 of the most popular Federal government publications, subscriptions and electronic products. Every bookstore can order any of over 12,000 titles for sale by GPO. Visit or contact any bookstore for more information. MasterCard and VISA are welcome.

- |                                 |                               |                                  |                               |
|---------------------------------|-------------------------------|----------------------------------|-------------------------------|
| ▶ <a href="#">Atlanta</a>       | ▶ <a href="#">Birmingham</a>  | ▶ <a href="#">Boston</a>         | ▶ <a href="#">Chicago</a>     |
| ▶ <a href="#">Cleveland</a>     | ▶ <a href="#">Columbus</a>    | ▶ <a href="#">Dallas</a>         | ▶ <a href="#">Denver</a>      |
| ▶ <a href="#">Detroit</a>       | ▶ <a href="#">Houston</a>     | ▶ <a href="#">Jacksonville</a>   | ▶ <a href="#">Kansas City</a> |
| ▶ <a href="#">Laurel</a>        | ▶ <a href="#">Los Angeles</a> | ▶ <a href="#">Milwaukee</a>      | ▶ <a href="#">New York</a>    |
| ▶ <a href="#">Philadelphia</a>  | ▶ <a href="#">Pittsburgh</a>  | ▶ <a href="#">Portland</a>       | ▶ <a href="#">Pueblo</a>      |
| ▶ <a href="#">San Francisco</a> | ▶ <a href="#">Seattle</a>     | ▶ <a href="#">Washington, DC</a> |                               |

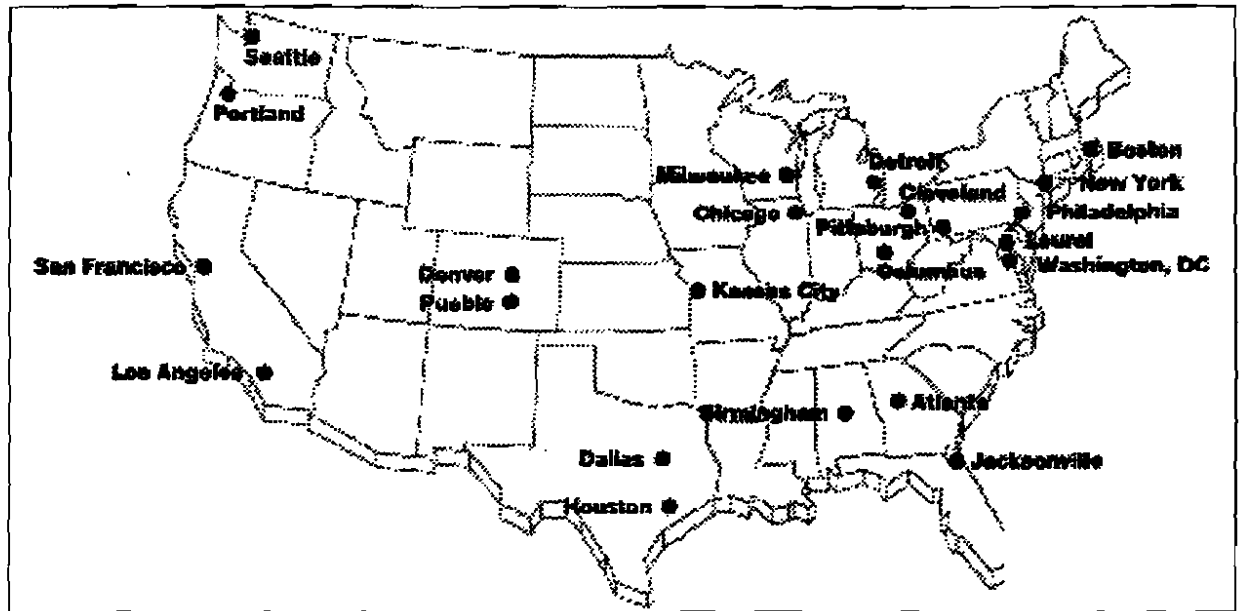

Questions or comments regarding this service? Contact the GPO Access User Support Team by Internet e-mail at [help@eids05.eids.gpo.gov](mailto:help@eids05.eids.gpo.gov), by telephone at 202-512-1530; or by fax at 202-512-1262.



# U.S. Government Bookstore Denver, Colorado

Room 117, Federal Building  
1961 Stout Street  
Denver, CO 80294

Hours: 8:30 a.m. - 4:00 p.m., Monday through Friday, except Federal holidays

Phone: (303) 844-3964  
Fax: (303) 844-4000

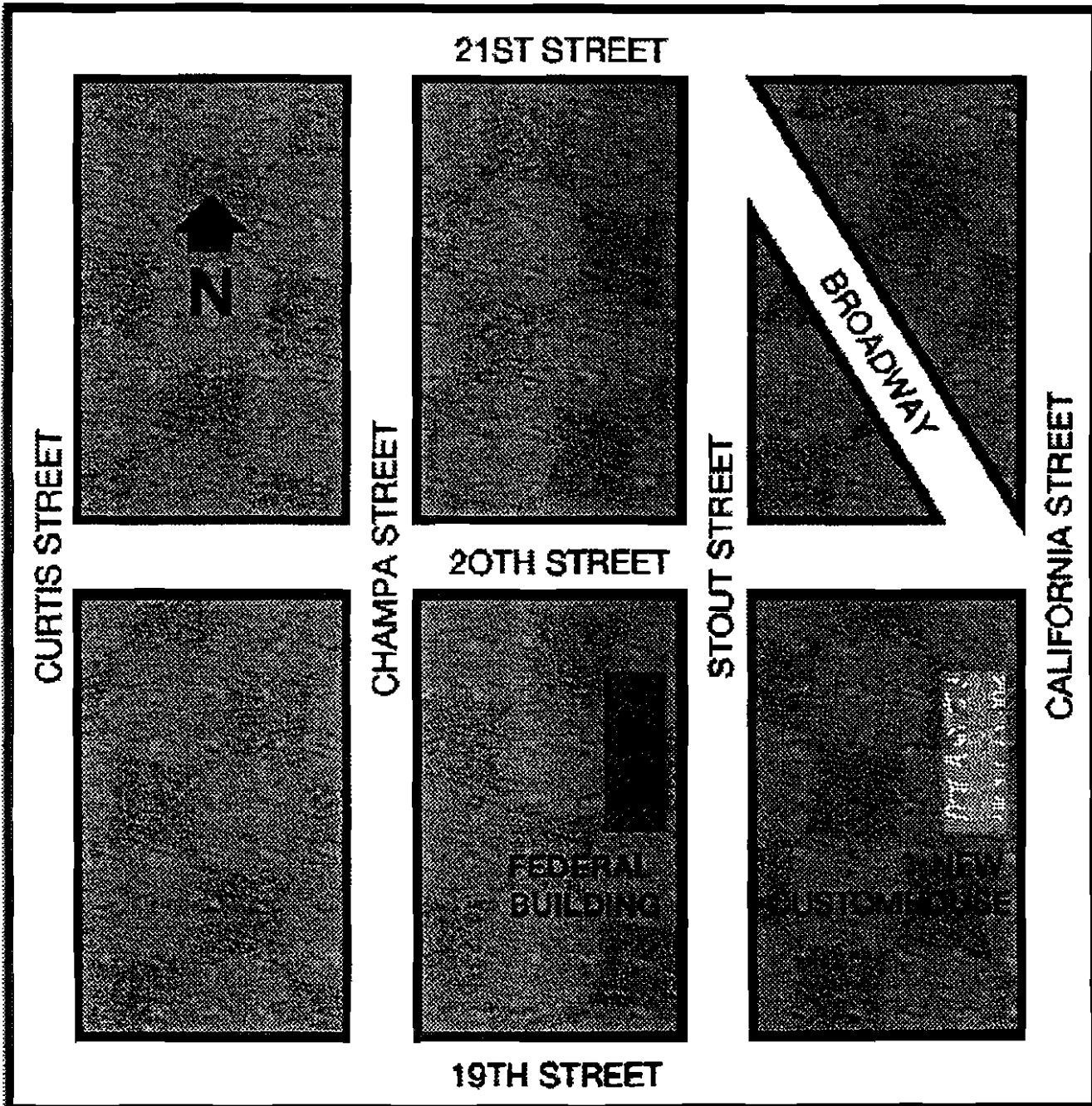

**Exhibit H:**

**1994 Federal Technology Leadership Award  
(Press Release, November 18, 1994);  
1995 James Madison Award  
(Press Release, March 15, 1995)**

# News Release



UNITED  
STATES  
GOVERNMENT  
PRINTING  
OFFICE

For Release : IMMEDIATE  
November 18, 1994

Contact: 202-512-1991  
No. 94-12

## GPO ACCESS EARNS 1994 FEDERAL LEADERSHIP AWARD

"To be able to serve the American public is in itself a reward. To see our efforts recognized with the presentation of such a prestigious honor serves to multiply our commitment to that service and increase our pride in what we do." With these words, Public Printer Michael F. DiMario responded to the announcement that GPO Access, the U.S. Government Printing Office (GPO) electronic information dissemination program, has earned a 1994 Federal Leadership Award.

The GPO Access service provides online access to the Congressional Record, the Federal Register, the full text of all published versions of bills introduced in Congress, the Congressional Record Index, the History of Bills, the Lobby List, the Unified Agenda, and, through the Federal Bulletin Board, more than 6,000 other files from 25 Federal agencies. In operation since June 1994, a recent addition to the program is 24-hour free online access to this valuable Government information through a telephone call to participating Federal depository libraries. The availability of this information at no cost has earned



GPO praise from citizens across the Nation.

GPO Access has four primary components for dissemination of Federal information:

- \* a system of online access to Federal publications, including the free access;
- \* an electronic directory or locator;
- \* an electronic storage facility;
- \* an electronic bulletin board service.

Federal Leadership Awards recognize "the Federal projects and programs that have made exceptional contributions to mission effectiveness, cost-effectiveness, and service to the public through the use of automated information systems." Recipients are judged by representatives of the General Services Administration, the Office of Management and Budget, the Department of Defense, and **Government Executive** magazine.

The 1994 Federal Leadership Awards will be presented on December 1, 1994, by John A. Koskinen, Deputy Director for Management, Office of Management and Budget.

# News Release



UNITED  
STATES  
GOVERNMENT  
PRINTING  
OFFICE

For Release: IMMEDIATE  
March 15, 1995

Contact: 202-512-1991  
No. 95-7

## GPO ACCESS EARNS 1995 JAMES MADISON AWARD

**GPO Access**, the electronic dissemination service of the U.S. Government Printing Office (GPO), has won a 1995 James Madison Award sponsored by the Coalition on Government Information. The Madison Awards are presented in celebration of Freedom of Information Day, March 16th, the birthdate of James Madison, and honor those who champion the public's right to know. The Coalition is composed of more than 40 member organizations committed to creating public awareness of access to and dissemination of Government information.

"Once again, it is particularly gratifying to see GPO recognized for its efforts to serve the American public. Our employees have great pride in the role they play in helping to keep their fellow citizens informed," Public Printer Michael F. DiMario said in acknowledging GPO's selection for a Madison Award.

Implemented in June 1994, the GPO Access system provides online access to the Congressional Record, the Federal Register, the full text of all published versions of bills introduced in Congress, the Congressional Record Index, the History of Bills, the Lobby List, the Unified Agenda of Federal Regulations, the

U.S. Code, Public Laws of the 104th Congress, and, through the Federal Bulletin Board, more than 6,000 other files from 25 Federal agencies. In addition, the program offers 24-hour free online access to Government information via the Internet from participating Federal depository libraries. Since its inception, citizens around the Nation have downloaded more than 750,000 Government documents.

GPO received the Madison Award, along with several other recipients, at a ceremony Wednesday, March 15, 1995, at the National Press Club. Other winners include: Town Hall, a production of the Internet Multicasting Service; the Sailor project - Maryland's Online Public Information Network; and the Seattle Public Library for its kiosk and other services that have expanded public access to information about Federal, State, and local government.

Among those singled out previously for Madison Awards were Vice President Albert Gore; Secretary of Energy Hazel O'Leary; Senators Wendell Ford, Ted Stevens, Frank Lautenberg, and Patrick Leahy; Representatives Charlie Rose, Bill Thomas, Henry Waxman, and Don Edwards; the EPA Office of Toxic Substances; and journalists Nina Totenberg, Brian Lamb, Scott Armstrong, and Philip Shabecoff.

The GPO Access service was previously honored in 1994 with a Federal Technology Leadership Award which was determined by representatives of the General Services Administration, the Office of Management and Budget, the Department of Defense, and Government Executive magazine.

**Exhibit I:**

**Federal Depository Libraries Sponsoring *GPO Access Gateways***

# Gateway Connections to *GPO Access*

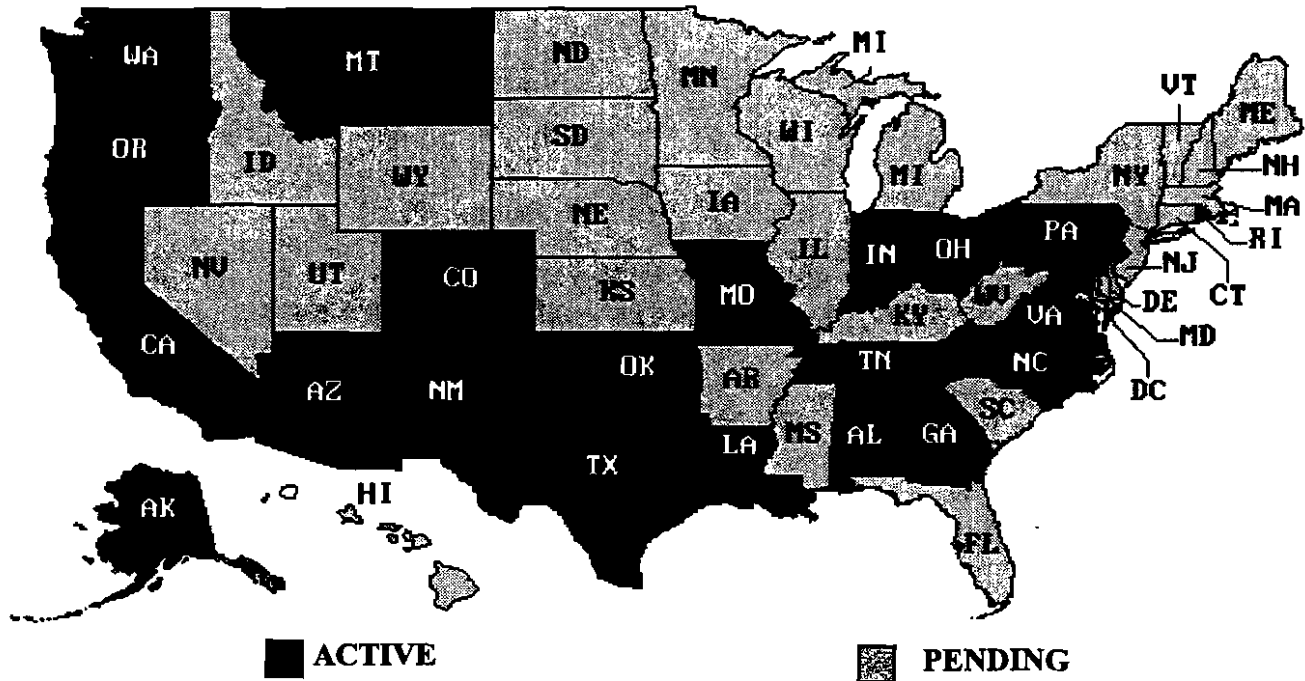

.....

Connect to a *GPO Access* Federal Depository Gateway  
See below for details.

## • WAIS Client Access via World Wide Web (WWW):

### Auburn University Library Gateway

**Instructions:** Point your Web browser to <http://www.lib.auburn.edu/gpo> or <http://auburn.edu/gpo/index.html>

**User Support:** Faculty of Microforms and Documents Department (334)884-1702

**Technical Contact:** Beth Nicol (334)844-1731 or [bnicol@lib.auburn.edu](mailto:bnicol@lib.auburn.edu)

### California - University of California

**Instructions:** Point your Web browser to <http://ssdc.ucsd.edu/gpo>

**User Support:** Trisha Cruse (619)534-4175 or [pcruse@ucsd.edu](mailto:pcruse@ucsd.edu)

### Indiana - Purdue University

**Instructions:** Point your Web browser to <http://thorplus.lib.purdue.edu/gpo>

**User Support:** Carl Snow (317) 494 - 2764 or [carl@smart.lib.purdue.edu](mailto:carl@smart.lib.purdue.edu)

**Technical Contact:** Bert Chapman at [chapmanb@sage.cc.purdue.edu](mailto:chapmanb@sage.cc.purdue.edu) or

### Louisiana State University Libraries

**Instructions:** Point your Web browser to <http://www.lib.lsu.edu/gpo>

Telnet to [indigo.lib.lsu.edu](http://indigo.lib.lsu.edu); login as `gpo` or dial 504-334-1096; press enter; type "dtigerla"; press enter 3 times at the 'connected' message; at the username prompt. press ctrl z; at the Xyplex prompt type "telnet indigo.lib.lsu.edu; login as gpo"

**User Support:** Kiran Prasana (504)388-4236 or [kprasa@unix1.sncc.lsu.edu](mailto:kprasa@unix1.sncc.lsu.edu)

**Maryland - SAILOR - Maryland's Online Public Information Network**

**Instructions:** Point your Web browser to <http://sailor.lib.md.us/forms/gpo.html>

**User Support:** Arleen Talley (410)396-5426 or [atalley@epfl.epflbalto.org](mailto:atalley@epfl.epflbalto.org)

**Tech Contact:** Agnes Tatarka (410)396-5551 or [admin@sailor.lib.md.us](mailto:admin@sailor.lib.md.us)

**Montana - Renne Library, Montana State University - Bozeman**

**Instructions:** Point your Web browser to <http://www.lib.montana.edu:80/GOVDOC/gpo.html>

**User Support:** Patrick Ragains (406)994-5294 or [alpr@gemini.oscs.montana.edu](mailto:alpr@gemini.oscs.montana.edu)

Bruce Albert (406) 994-5306 or [aliba@gemini.oscs.montana.edu](mailto:aliba@gemini.oscs.montana.edu)

**New Mexico - University of New Mexico Zimmerman Library**

**Instructions:** Point your Web browser to <http://www.unm.edu/~cmclean/gpo.html>

**User Support:** Maria Teresa Marquez or Clark McLean or [govref@unm.edu](mailto:govref@unm.edu) or phone (505) 277-5441  
or fax: 505-277-6019

**North Carolina - North Carolina State University Libraries Gateway**

**Instructions:** Point your Web browser to <http://www.lib.ncsu.edu/stacks/gpo/>

(Telnet option) Telnet to [library.ncsu.edu](http://library.ncsu.edu) and login as LIBRARY. From the NCSU Libraries Information System Main Menu, choose #2, Journal Article Indexes, then #2, GPO Access.

**User Support:** Mary Ellen Spencer (919)515-4221 or [me\\_spencer@ncsu.edu](mailto:me_spencer@ncsu.edu)

**Ohio - WINSLO - (World Wide Web Information Network, State Library of Ohio)**

**Instructions:** Point your Web browser to <http://winslo.ohio.gov/gpo>

**User Support:** State Library of Ohio Help Desk (614)728-8627 or [nberends@mail.slonet.ohio.gov](mailto:nberends@mail.slonet.ohio.gov)

**Oklahoma - Oklahoma State University**

**Instructions:** Point your Web browser to <http://www.okstate.edu.gpolink.htm>

**User Support:** Suzann Holcombe (405)744-6546 or [slatour@okway.okstate.edu](mailto:slatour@okway.okstate.edu)

**Tennessee - University of Tennessee, Knoxville Libraries**

**Instructions:** Point your Web Browser to <http://www.lib.utk.edu/gpo/govdoc.html>

**User Support:** Bill Britten (615)974-4304 or [bill@aztec.lib.utk.edu](mailto:bill@aztec.lib.utk.edu)

**• WAIS Client Access via Lynx World Wide Web browser:**

**North Carolina - University of North Carolina-Chapel Hill**

**Instructions:** Telnet to [library.unc.edu](http://library.unc.edu), or dial (919) 962-9911, at 300-14.4 baud. Login as **library**. There is no password. Users of GPO Access should select Government Databases (#2) and option 2 again for GPO Access.

**User Support:** Ridley Kessler (919) 962-1151 or [kessler.davis@mhs.unc.edu](mailto:kessler.davis@mhs.unc.edu) Tech. Contact: Derek Rodriguez (919)962-1288 or [Derek\\_Rodriguez@unc.edu](mailto:Derek_Rodriguez@unc.edu)

## • Via SWAIS:

### Alaska - SLED - Alaska's Statewide Library Electronic Doorway

**Instructions:** Telnet to sled.alaska.edu. Within Alaska dial into via the AlaskaNet node nearest you or, for questions, dial 1- (800) 478-4667. Once connected with SLED, press the return key to continue; at the SLED Main Menu, choose Government Information (#5); then choose Federal Government Information (#2); choose GPO Access under Federal Government Information (#4).

**User Support:** Walt Herried ffw@aurora.alaska.edu

### Arizona - Aztec (Arizona Telecommunication Community)

**Instructions:** Telnet to aztec.asu.edu or dial in (602) 965-4151 or at 9.6, 14.4 or 28.8 baud at (602) 965-6699. Login as **guest**; password is **visitor**. From the Main Menu, select option #2, Government Databases, then option #2 Federal Government, and finally option #3 for GPO Access Online Services.

**User Support:** Joe Askins (602)965-5985 or joe.askins@asu.edu

### Colorado - CARL Colorado Assoc. of Research Libraries, in cooperation with Univ. of CO - Denver

**Instructions:** Telnet to csn.carl.org. Dial in (2400 baud or higher) at 303-758-1551. No login or password is required. From Groups of Databases, select option #1, Library Catalogs. Then select #22, Government Publications, then #75 for GPO Access.

**User Support:** George Machovec (303)758-3030 ext. 156 or gmachove@carl.org

### Colorado - Pueblo Library District

**Instructions:** Telnet to PLDVAX.PUEBLO.LIB.CO.US or use the IP address of 198.247.6.1) Dial (719) 542-7629 (up to 9600 baud). Press <enter> to obtain a prompt. Login as **library**. Then select (#6) from the Main Menu.

**User Support:** Robert Farries (719) 543-9600 or bob@pueblo.lib.co.us

### District of Columbia - Georgetown University

**Instructions:** Telnet to library.georgetown.edu. Login as **gpo**. Follow the prompts.

*For a modem connection up to 9600 baud, dial 202-687-3052. To obtain the prompt, press <enter> twice. When prompted for a login password, type **access**, all lower case. Press <enter> to continue, then select GPO Access. (#1). When prompted for the next login, type **gpo**.*

**User Support:** Joan Cheverie (202)687-7467 or jcheverie@guvax.georgetown.edu Tech. Contact: Steve Jackson sjackson@guvax.georgetown.edu

### Georgia - Georgia Southern University

**Instructions:** Telnet to gsvms2.cc.gasou.edu, or dial into GSnet at (912) 681-0005 (9600 baud). To obtain the GSnet prompt, press <enter> twice. From the GSnet prompt, enter the following commands: **connect gsvms2**. Users with slower modems (1200 baud) may dial PeachNet at (912) 681-0500. From the PeachNet prompt, enter: **connect gsvms2.cc.gasou.edu**. (All four periods in the command are significant, including the final one.) Once connected with gsvms2, users should enter **INFO** as their username; no password required. From the Public Information Services menu select GPO Access.

**User Support:** Lynn Walshak (912)681-5032 or soliblw@gsvms2.cc.gasou.edu Tech. Contact: David Ewing (912) 681-5364 or dewing@gasou.edu

### **Louisiana - Louisiana State University Libraries**

**Instructions:** Telnet to indigo.lib.lsu.edu; Login as gpo, no password. Dial 504-334-1096; press enter; type "dtigerla", press enter three times at the 'connected' message; at the username> prompt, press <ctrl> z; at the Xyplex> prompt type "telnet indigo.lib.lsu.edu"; login "gpo".

**User Support:** Kiran Prasana (504-388-4236 or kprasa@unix1.sncc.lsu.edu)

### **Missouri - COIN - Columbia (Mo.) Online Information Network**

**Instructions:** Telnet to telnet.coin.missouri.edu, or dial (314) 884-7000. Login as guest; no password. From the Main Menu select "Government Center; then #6, United States of America and finally; #14, GPO Access.

**User Support:** Marilyn McLeod (314)443-3161 or mmcleod@mail.coin.missouri.edu

### **Ohio - Case Western Reserve University**

**Instructions:** Telnet to catalog.cwru.edu. Once connected with EuclidPLUS, select "GPO Access." Dial into Cleveland Free-Net at (216) 368-3888 at 300-14.4 baud. In order to use Cleveland Free-Net, users must be registered, which can be done online free of charge. Once registered, select "The Library", then "CWRU Libraries", then "University Library", then "EuclidPLUS." Within EuclidPLUS, select "GPO Access."

**User Support:** George Barnum (216)368-6512 or gdb2@po.cwru.edu

### **Oregon - Portals Oregon**

**Instructions:** Gopher to portals.pdx.edu. No login is required. From the Portals Main Menu, select option #1, Databases; then option #6, Federal Government Documents. From there, options 1-6 will connect to GPO Access. Users can dial (503)227-3962 up to 9600 baud. From the Multnamah County Library Dialup Information System Main Menu, select option 36 Portals; then follow the instructions above.

**User Support:** Millard Johnson (503) 725-5049 or zendog@lib.pdx.edu

### **Pennsylvania - Penn State University's Library Information Access System**

**Instructions:** Telnet to LIAS.psu.edu, or dial (814) 865-5427, at 300-14.4 baud. Once connected with LIAS, press <enter> and respond to the prompts for terminal emulation. When prompted for a "Penn State ID Number," press <enter>. No password is required. The LIAS Welcome Screen will appear. From there type SELECT to go to the selection menu, and then choose "GPO Access." An extensive help message is available by typing " help gpo" at the LIAS prompt.

**User Support:** Debora Cheney (814) 863- 1345 or dlc@psulias.psu.edu

### **Pennsylvania - Ursinus College**

**Instructions:** Telnet to lib.ursinus.edu. Login as library. GPO Access is choice #7 on the gateway menu. Modem users dial (610) 409-3616. Once connected, press the return key once or twice. Choose the library option; GPO Access should be choice #7 on the menu.

**User Support:** Bebbie Malone (610) 489-4111 ext. 2460 or dmalone@lib.ursinus.edu  
Tech. Contact: David Mill (610)489 - 4111 ext 2283 or dmill@lib.ursinus.edu

### **Rhode Island - Ocean State Free Net - ( in cooperation with Rhode Island Federal Depository Libraries)**

**Instructions:** Telnet to osfn.rhilinet.gov, or dial (401) 658-3995. (Other numbers available.) Login as guest. password is guest. From the Main Menu, choose Gov't Cntr. (# 8); then Federal information; then select GPO Access.

*Please Note: A limited number of simultaneous connections is available on GPO Access. If all connections are in use, you'll be told to "try again later."*

**User Support:** Dan O'Mahony (410) 863-2522 or ap201159@brownvm.brown.edu



### Tennessee Technological University

**Instructions:** Telnet to atlas.tntech.edu, or dial (615) 372-6160. Username is **PAC**. Choose Find from the menu bar, then choose Database, and select GPO Access (Federal Info).

**User Support:** Regina Lee (615)372-6105 or ral5467@tntech.edu

### Tennessee - University of Memphis

**Instructions:** Telnet to msuvx1.memphis.edu, and login as **library** or dial (901) 678-3600 (19,200 baud) and login as **guest**. Connect to University Library. From the Main Menu select Find: Then choose Database; select **GPO Access**.

**User Support:** Sandra Williams (901) 678-2206 or willias@cc.memphis.edu  
Tech. Contact: Phil Smith (901) 678-4399 or smithp@cc.memphis.edu

### Texas - Texas State Library

**Instructions:** Telnet to link.tsl.texas.gov, or dial (512)475-4444. Login as **link**, all lower case. Once connected to the Texas State Electronic Library, select choice (#15), Find a Menu Item in the Electronic Library by Keyword. Enter **gpo** as the word to search. You will then see a gopher client listing of **GPO Access** databases.

**User Support:** Diana Houston (512)463-5426 or diana\_houston@tsl.texas.gov  
Tech.Support Christine Masleid (512) 463-5528.

### Virginia - University of Virginia

**Instructions:** Telnet to gwis.virginia.edu. Login as **gwis**. Choose Library Services: Social Sciences Data Center; Government Printing Office; **GPO Access**. *For a modem connection, dial (804)982-5966. At the "Connect" prompt, type telnet gwis<enter>; login and password are both gwis.*

**User Support:** Walter Newsome (804)924-4963 or wln@virginia.edu

### Washington - Seattle Public Library

**Instructions:** Telnet to spl.lib.wa.us (198.137.188.2), or dial (206) 386-4140. Login as **library** (all lower case) and answer the terminal emulation questions. Select "Internet" off both the first and second menus. From the Gateways menu, select **GPO Access**.

**User Support:** Patrick Grace (206)386-4139 Technical Contact: Jim Taylor (206) 386-4169 or jtaylor@spl.lib.wa.us

**NOTE:** Modem settings are 8 data bits, full duplex, no parity, 1 stop bit; terminal emulation is VT100. Unless otherwise specified, modem connections are at 2400 baud.

**Interested in becoming a gateway?** Contact Gil Baldwin or William Thompson at (202) 512-1002, Fax (202) 512-1432, or Internet email <manage@access.digex.net>.