

V-1

D1737

Filed: Vol. 3

historic structure report

march 1981

VICKSBURG

U.S.S. CAIRO

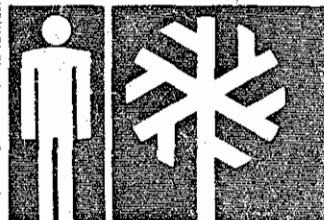

NATIONAL MILITARY PARK / MISSISSIPPI

ON MICROFILM

PLEASE RETURN TO:
 TECHNICAL INFORMATION CENTER
 DENVER SERVICE CENTER
 NATIONAL PARK SERVICE

SCANNED

7/19/01

HISTORIC STRUCTURE REPORT

U.S.S. CAIRO
VICKSBURG NATIONAL MILITARY PARK
VICKSBURG, MISSISSIPPI

By
Tom McGrath
Doug Ashley

United States Department of the Interior
National Park Service
Denver Service Center

CONTENTS

PREFACE / ix

SYNOPSIS / xi

I. ADMINISTRATIVE DATA SECTION / 1

- A. Project Identification / 1
- B. Significance / 1
- C. Management / 1
- D. Description of the Cairo Site / 1
- E. Cooperative Agreements / 2

II. HISTORICAL DATA SECTION / 3

III. ARCHITECTURAL DATA SECTION / 4

- A. Summary of Prior Documentary Materials / 4
 - 1. Historic City Class Gunboat Plans and Specifications, 1861 / 4
 - 2. Historic Photographs, 1862 / 4
 - 3. Modern Photographs, 1960-1978 / 4
 - a. Cairo Raising and Reassembly in Pascagoula, 1960-1965 / 4
 - b. Cairo Existing Conditions, November 1976 / 5
 - c. Film Stereopairs of Cairo, February 1977 / 5
 - d. Dismantling and Cleanup of the Cairo at Pascagoula, 1977 / 5
 - 4. Prior Cairo Research / 5
 - a. "U.S.S. Cairo, Planning and Research," Barry Howard and Assoc. Inc., 1976 / 5
 - b. "Boat Restoration Study," Barry Howard and Assoc. Inc., 1976 / 5
 - c. Schematic Drawings (Geoghegan) / 5
 - (1) Drawings Prepared in 1960 / 5
 - (2) Drawing Prepared in 1970 / 5
 - (3) Drawings Prepared in 1977-1978 / 6
 - d. Reports and Drawings by Naval Architectural Consultant Comdr. USCG (ret.) J. Delano Brusstar / 6
 - (1) "Planning Schedule - Gunboat Cairo," 1968 / 6
 - (2) "Feasibility of Transportation and Reconstruction, 1968 / 6
 - (3) Record Drawings, 1968 / 6
 - e. NPS Records of Dismantling and Transport of Cairo from Pascagoula to Vicksburg National Military Park / 8
 - (1) Site Cleanup and Transport Log, 1977 / 8
 - (2) Wood Preservation Data Notebook, 1977 / 8
 - (3) Sketch Detail Drawings, 1977 / 8

- B. Description of Recovery and Existing Conditions / 8
 - 1. Discovery to Vicksburg, 1956-1977 / 8
 - a. Operation Cairo, 1960-1964 / 8
 - b. Cairo raising, 1960-1964 / 11
 - c. Storage and Reassembly in Pascagoula, 1965-1977 / 15
 - d. Transport to Vicksburg, 1977 / 21
 - 2. Description of the Cairo Complex / 23
 - a. Display Berth / 23
 - b. Cover Structure / 23
 - c. Restoration Shop / 26
 - d. Cairo Museum / 26
 - 3. NPS Cairo Research and Fabric Investigation / 26
 - a. Historic Description of the Cairo / 26
 - (1) The Development of the City Class Design / 26
 - (2) Technical and Descriptive Data on the Historic Cairo / 30
 - (3) Discussion of the Historic Propulsion System / 36
 - (4) Discussion of Historic Armor / 38
 - b. Discussion of Hull Structure / 39
 - c. The Cairo Research Model and "As-Built" Cairo Drawings / 41
 - d. 1980 Status/Current Fabric Condition / 44
 - (1) Wood Fabric / 47
 - (a) Biological Decay / 48
 - (b) Chemical Decay / 49
 - (c) Weathering / 49
 - (d) Moisture-Related Dimensional Changes / 50
 - (2) Metal Fabric / 52
 - (3) Cairo Structural Integrity / 52
 - (a) Historic Gunboat Framework / 52
 - (b) Pascaquola Reassembly Support Remains / 53
 - (c) Transport Structure / 53
 - e. Technical Alternatives for Treatment / 54
 - (1) Wood Preservation / 54
 - (a) Types of Wood Preservation / 54
 - (i) Oilborne Fungicides / 54
 - (aa) Cresote / 54
 - (bb) Pentachlorophenol / 55
 - (cc) Tricutyln Oxide / 55
 - (ii) Waterborne Preservatives / 55
 - (aa) CZC (Chromated Zinc Chloride) / 55
 - (bb) FCAP (Flour-chrome-arsenic, phenol) / 55
 - (cc) CCA (Chromated Copper Arseuate) / 56
 - (dd) ACA (Ammoniacal copper) / 56
 - (ee) ACC (Acid Cupric Chromate) / 56
 - (b) Application of Preservatives / 56
 - (c) Wood Fabric Preservation Options / 57
 - (i) Option I - Wood Fume / 58
 - (ii) Option II - Hydrozo/Penta / 59
 - (iii) Option III - Linseed Oil/Penta / 60
 - (iv) Option IV - Peg/PG - 57 / 61

- (2) Metal Preservation / 62
 - (a) In-place Metal Fabric Preservation Options / 62
 - (i) Option I - No Treatment / 63
 - (ii) Option II - Zinc Paint, Black Enamel Paint / 63
 - (iii) Option III - Coal Tar Epoxy / 64
 - (b) Unattached Metal Fabric Preservation Options / 65
 - (i) Option I - No Treatment / 65
 - (ii) Option II - Sand Blasting Followed by Primer and Black Enamel Paint / 65
- C. Cairo Restoration Program Alternatives / 67
 - 1. Alternative A - Minimum Preservation / 67
 - a. Discussion / 67
 - b. Estimated Cost / 67
 - 2. Alternative B - Minimal Preservation and Restoration / 67
 - a. Discussion / 67
 - b. Necessary Tasks to Complete Alternative B / 68
 - c. Estimated Costs / 69
 - 3. Alternative C - Partial Restoration I / 69
 - a. Discussion / 69
 - b. Necessary Steps to Complete Alternative C / 70
 - c. Estimated Costs / 71
 - 4. Alternative D - Partial Restoration II / 71
 - a. Discussion / 71
 - b. Necessary Steps to Complete Alternative D / 72
 - c. Estimated Costs / 73
 - 5. Alternative E - Partial Restoration III (Selected Alternative) / 73
 - a. Discussion / 73
 - b. Necessary Steps to Complete Alternative E / 74
 - c. Estimated Costs / 76
 - d. Package Estimating Detail / 77
 - 6. Alternative F - Half Preservation/Half Reconstruction / 78
 - a. Discussion / 78
 - b. Necessary Steps to Complete Alternative F / 78
 - c. Estimated Costs / 79
 - 7. Alternative G - Theatrical Reconstruction, and Alternative H - Historical Reconstruction / 79
 - a. Discussion / 79
 - b. Estimated Costs / 79
 - 8. Alternative I - Restoration Plus Full Reconstruction / 81
 - a. Discussion / 81
 - b. Estimated Costs / 82
 - 9. Notes / 82

DRAWINGS FOR CAIRO RESTORATION / 83

APPENDIXES / 145

GLOSSARY / 167

BIBLIOGRAPHY / 171

ILLUSTRATIONS

Title Page: Historic Photo: U.S.S. <u>Cairo</u>	/	vii
1: Pilothouse Raising	/	12
2: Raising the Gunboat	/	14
3: Midships Recovery	/	16
4: Arrival in Pascagoula	/	18
5: <u>Cairo</u> Reassembly	/	19
6: <u>The Cairo</u> Rotting	/	22
7: Site Plan of <u>Cairo</u> Display Area	/	24
8: Section and Elevation of Cover Structure	/	25
9: <u>Cairo</u> Sister Ship, the U.S.S. <u>Cincinnati</u>	/	27
10: Gunboats Under Construction	/	31
11: The Carondelet Shipyard	/	32
12: The Research Model	/	42
13: Port View, <u>Cairo</u> Research Model	/	43
14: Interior View of <u>Cairo</u> Research Model	/	45
15: Model Detail	/	46

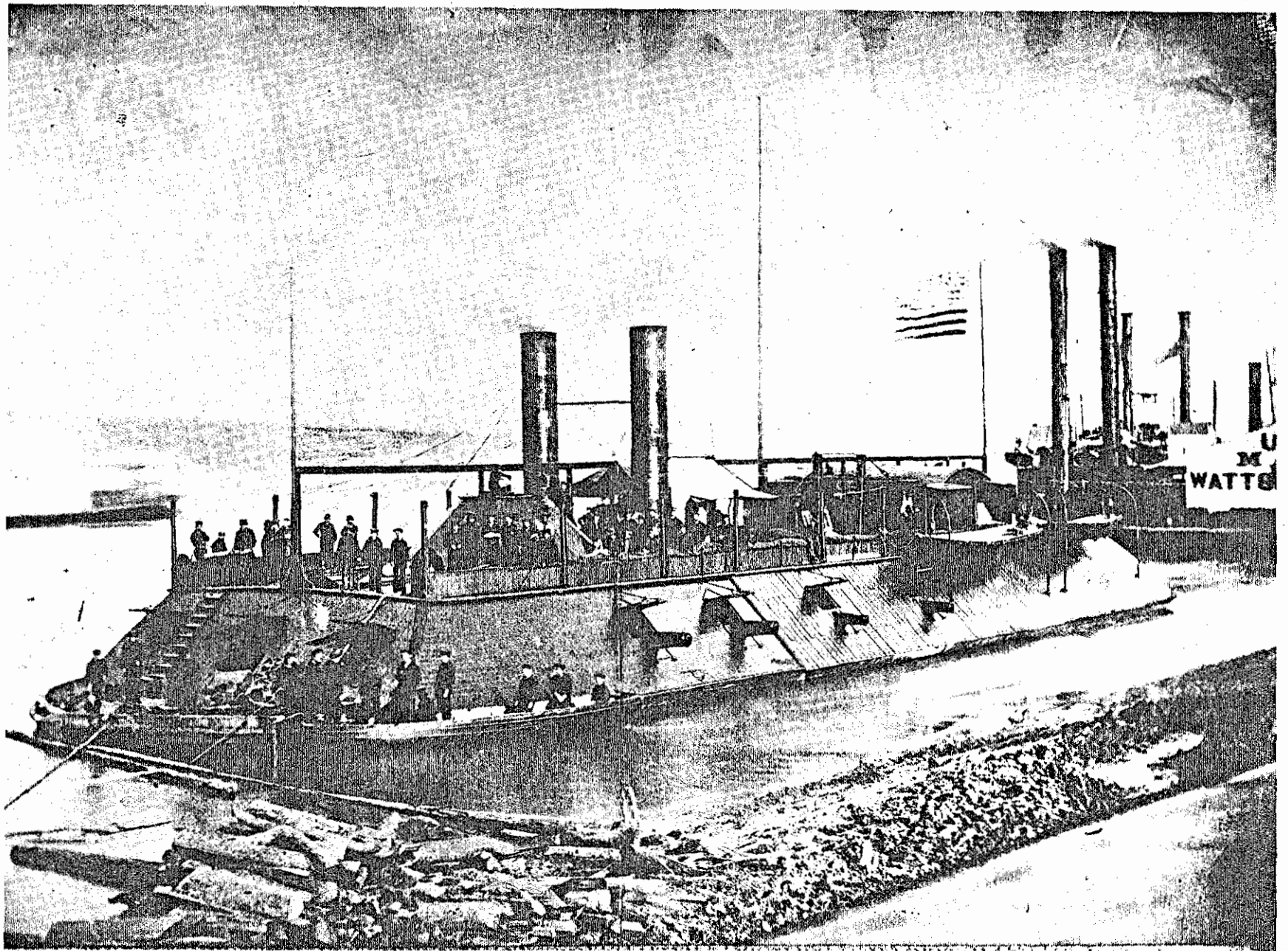

PREFACE

This document describes the program for the preservation and display of the Civil War gunboat U.S.S. Cairo located at Vicksburg National Military Park, Vicksburg, Mississippi. The analysis and recommendations in the following pages were first outlined for National Park Service management in an interim Cairo report in April 1979, at which time restoration alternative E was selected. Since this selection, we have been able to develop and expand our analysis, discussion, and cost evaluations for this "Historic Structure Report." The unchosen alternatives from our April report have been included without change.

Those familiar with the Cairo project understand that the nature of the work will preclude normal construction documents and specifications. Accordingly, most specific design, assembly, and preservation decisions will be made during the course of work by the project supervisor. Where the work can be accurately described beforehand, as with the ironclad's support structure and fabric preservation techniques, our report is quite specific and is intended, along with the Cairo study model, to be a working guide for the project supervisor and his day-labor staff. Miscellaneous drawings for project work will be produced by the Denver Service Center as required.

We would like to thank Vicksburg National Military Park Superintendent Dan Lee, Administrative Officer Geri Herrmann, Chief of Maintenance David Lyons, and the rest of the park staff for their continued support and friendship during our lengthy and frequently demanding research effort. Denver Service Center architects Harold LaFleur and George Thorson have provided invaluable assistance, guidance, and advice throughout the preparation of this report. Finally, we would like to thank Mr. and Mrs. Edwin Bearss for sharing their vast personal knowledge and records of the U.S.S. Cairo.

Doug Ashley
Tom McGrath

SYNOPSIS

The U.S.S. Cairo served Union forces for approximately 11 months, from January 1862 to December 1862, when she was sunk by a submerged Confederate torpedo (mine) in the Yazoo River near Vicksburg, Mississippi. She was rediscovered in 1956 and has since been salvaged.

The treatment for the Cairo will be preservation and partial restoration. Where replacement of missing or unsalvageable Cairo fabric is essential to the structural integrity of existing parts of the ship or to the visitor's understanding of her operation, partial reconstruction will take place. All remaining historic fabric will be preserved and identifiable surviving fabric will be remounted onboard the restored gunboat to once again become part of the original ship form. The restoration will permit interpretation of the blast hole in the Cairo bow and represent the vessel as she was when sunk.

Upon completion of the restoration project, public access will be by a pedestrian bridge traversing the Cairo at approximately midships. Interpretation onboard and around the perimeter of the Cairo will be conducted on a self-guided tour basis.

This program is described in detail in the body of this report and was selected in April 1979 after study of a full range of technical preservation options and restoration program alternatives. Other proposals studied are briefly described. In summary, the following steps are to be taken:

Wood Fabric Preservation. The recommended Cairo wood preservation treatment is option IV, seven to ten consecutive days spray application of a PEG/PQ-57 solution to all Cairo wood fabric.

Metal Fabric Preservation. For in-place metal fabric, option II is recommended. This calls for a four-step, three-coat process consisting of (1) mechanical cleaning of the rusted metal, (2)

brush-on treatment with manganese-phospholene, (3) painting with a zinc silicate solution, and 4) a final paint coat of black enamel. For unattached fabric, the recommendation is option II: mechanical cleaning of the exfoliated metal fabric by sandblasting followed by a red lead primer and a final coat of black enamel paint.

Restoration Program. Alternative E - "Partial Restoration III" is the selected course of action. At an estimated cost of \$2,450,000, this proposal will stabilize and mount on the Cairo all existing identifiable historic fabric, build a covering structure, and provide for visitor interpretation. A specially designed glue-laminated wood structural system will permit limited onboard visitation, provide support for the gunboat fabric, and "ghost" the lines and forms of the missing parts of the warship. Work has begun on this alternative.

I. Administrative Data Section

A. Project Identification

This "Historic Structure Report" is concerned with the Civil War gunboat U.S.S. Cairo, which is located within the 1,753-acre Vicksburg National Military Park in and around the city of Vicksburg, Mississippi. The vessel will be the central focus of an interpretive complex including a museum displaying artifacts from the boat and describing its history, a temporary restoration shop (completed), and a covering structure for the gunboat. The shelter and museum were completed in 1980, and target for the Cairo restoration is 1982.

B. Significance

The Cairo is listed on the National Register of Historic Places and is classified as a structure of national significance. The vessel is on the list of classified structures, #07283. The level of investigation for the gunboat will be class "A" in accordance with the National Park Service "Activity Standards."

C. Management

Vicksburg National Military Park is part of the southeast region of the National Park System and is managed by a superintendent whose address is Box 349, Vicksburg MS 39180. Planning is guided by a General Management Plan approved in July 1980 and a 1974 "Interpretive Prospectus."

D. Description of the Cairo Site

The entire Cairo complex site is within Vicksburg National Military Park in a picturesque field at the base of a small rise. Adjoining the national cemetery in the northwest section of the park, the site overlooks the Yazoo channel which now follows what was the De Soto bend of the Mississippi River.

The developed gunboat site will be fully landscaped with brick-paved viewing terraces, platforms, and walkways immediately surrounding the excavated ship foundation. Set at her approximate waterline within a dry berth, the Cairo is intended to be symbolically

viewed as within a river environment and will dominate the scene. Accentuating the torpedo-damaged bow will be an architecturally exciting brick-paved terrace, which by radiating from the blast hole, will visually represent the explosion that sank the ironclad.

Access to the Cairo site is by the Fort Hill entrance to the park or by Union Avenue, a 13-mile loop from the park's visitor center. No public transit facilities serve the location. Access to the display area from the parking lot is by pedestrian ramps. The entire site will be fully accessible to the physically handicapped.

E. Cooperative Agreements

There will be no cooperative agreements concerning the gunboat's preservation, but an agreement may be made for sales of related items within the museum.

II. Historical Data Section

Hardluck Ironclad, The Sinking and Salvage of the Cairo by Edwin C. Bearss, is the historical data section for this report. It was published by the Louisiana State University Press in 1966 and revised in 1980. Mr. Bearss is a National Park Service historian.

III. Architectural Data Section

A. Summary of Prior Documentary Materials

1. Historic City Class Gunboat Plans and Specifications, 1861

The research for engine, doctor, auxillary engine, pitman arm and assembly, and boiler face drawings in this report utilized field notes and the original drawings. A copy of the historic set of construction specifications and a framing plan for the entire City Class series gunboats are included in appendix A. During the course of construction, as well as during the wartime service of the Cairo, several details of the boat were changed significantly from the original City Class design and specifications. The Cairo is being restored to her appearance at the time of sinking.

2. Historic Photographs, 1862

Most known Cairo or City Class gunboat photographs taken during the war are in Miller's Photographic History of the Civil War, volume I, Opening Battles, and volume VI, The Navies. The title page photograph is the only known photo of the Cairo. Figures 10 and 11 show two City Class gunboats under construction at Carondolet, Missouri.

3. Modern Photographs, 1960-1978

a. Cairo Raising and Reassembly in Pascagoula, 1960-1965

The collection of photographs taken by the Mississippi Agricultural and Industry Board during the raising and by the Ingalls Shipyard just after the reassembly of salvaged Cairo fabric was the single most important source of documentary information for this research effort. Although these photographs were not the result of a preconceived systematic photo documentation, they do show most Cairo fabric before the onset of the massive deterioration that occurred during the 12 years of storage in Pascagoula. Without the aid of these photographs, the accuracy and scope of any Cairo preservation effort would be severely limited.

b. Cairo Existing Conditions, November 1976

This set of approximately 25 black-and-white prints taken by NPS architect Jim Smeal clearly illustrates the advanced state of deterioration and neglect that the Cairo had reached after her stay at Ingalls Shipyard.

c. Film Stereopairs of Cairo, February 1977

A set of 42 two-inch-square film stereopairs was taken at Pascagoula in early 1977 under a NPS contract by P.E. Borchers of Ohio State University. They were intended to ensure a photographic record of the Cairo prior to dismantling and transport to Vicksburg. Because of their small size, these photographs have contributed little to the project research.

d. Dismantling and Cleanup of the Cairo at Pascagoula, 1977

A one-volume set of both color slides and black-and-white prints taken by Jim Smeal documents the 1977 cleanup, dismantling, and crating of the Cairo components at Pascagoula, Mississippi, for shipment to Vicksburg NMP.

4. Prior Cairo Research

a. "U.S.S. Cairo, Planning And Research," Barry Howard and Assoc., Inc., 1976

This report develops a comprehensive exhibit strategy for the Cairo project. Historic, artifact, and interpretive research, as well as preliminary exhibit design schemes for the gunboat and adjacent museum, are analyzed. Although this report assumed major reconstruction of the Cairo, which would have included extensive onboard visitation and interpretation, it is nonetheless the seminal source for the exhibit themes and interpretive directions planned for the Cairo complex.

b. "Boat Restoration Study," Barry Howard and Assoc., Inc., 1976

Three years after acquiring title to the Cairo, the National Park Service commissioned the Howard firm to analyze structural

and interpretive considerations pertinent to the anticipated restoration/reconstruction of the ironclad.

The report first evaluated the then-current notion of 3/4 restoration-1/4 reconstruction of the gunboat; because of the noticeable deterioration of the vessel during the previous decade in Pascagoula and because of escalating costs, the report dismissed this approach as infeasible. Three alternative plans for the restoration and display of the Cairo were then developed. All three alternatives envisioned substantial reconstruction of the warship. Although major reconstruction is not the chosen alternative in this "Historic Structure Report," many of the concepts introduced under option III of the Howard study have been incorporated in this report's recommended gunboat display treatment. The Howard firm's "Boat Restoration Study" also recommended further investigation into areas that the research for the "Historic Structure Report" has covered: first, complete documentation of the remaining Cairo structure, and second, a specific analysis of the proper chemical preservation treatment for the gunboat wood and metal fabric.

c. Schematic Drawings (Geoghegan)

(1) Drawings Prepared in 1960

Prior to the raising of the Cairo, Mr. W.E. Geoghegan of the Smithsonian Institution prepared two schematic drawing sheets of a City Class type gunboat. These sheets include an inboard profile, port-side gun deck plan, partial longitudinal section at the wheelhouse, a one-half transverse section, hurricane deck plan, outboard profile, one-half profile of both bow and stern, and a one-half transverse section forward of the boilers and the port engine at the wheelhouse.

(2) Drawing Prepared in 1970

In 1970 Mr. Geoghegan completed an additional Cairo drawing sheet containing sketches depicting a schematic port-side gun deck plan, inboard profile, body plan, and partial longitudinal section through the starboard catamaran at the paddle wheel block.

(3) Drawings Prepared in 1977-1978

Mr. Geoghegan added new information to a three-sheet set of Cairo drawings completed during 1977-78 showing preliminary plans of the port-side half hurricane deck framing, inboard framing profile, transverse framing section at frame #60, port-side gun deck framing, inboard profile of the starboard hull side, boiler deck hold plan, and a boiler and gundeck longitudinal section.

The last of the Geoghegan drawings are three separate sheets drafted in 1977-1978 dealing respectively with (1) the interior forwarded casemate at the gundeck centerline; (2) navy 8-inch-shell gun loading positions (plan and profile); and (3) the port engine, block, and pitman arm (plan and profile).

d. Reports and Drawings Prepared by Naval Architectural Consultant Comdr. USCG (Ret.) J. Delano Brusstar

This material is among the papers describing the Cairo but was not considered a reliable source of information by the NPS team.

(1) Planning Schedule - Gunboat "Cairo", 1968

This three page report outlines the time the author estimated it would take to move the Cairo from Pascagoula to Vicksburg and then complete the proposed reconstruction work.

(2) Feasibility of Transporting and Reconstruction, 1968

This brief and cursory report is based on numerous doubtful assumptions about reconstructing the Cairo.

(3) Record Drawings, 1968

One sheet of drawings shows a longitudinal plan, starboard-side gun deck plan, section through the wheelhouse, section between stations (meaning frames 60 and 70), and officers' and captains' quarters layout. These are not fully accurate.

e. NPS Records of Dismantling and Transport of Cairo from Pascagoula to Vicksburg National Military Park

(1) Site Cleanup and Transport Log, 1977

A daily log kept by Jim Smeal from February 19 to April 19, 1977, notes the daily events that occurred during the dismantling, cleaning, and shipping of the Cairo fabric from Pascagoula to Vicksburg. One item of particular interest was the spray treatment of the Cairo with Hydrozo/5% penta wood preservative prior to its transit to Vicksburg.

(2) Wood Preservation Data Notebook, 1977

This notebook is a collection of miscellaneous articles and manufacturers' technical data relating to wood preservation compiled by Mr. Smeal during his tenure in Pascagoula.

(3) Sketch Detail Drawings, 1977

Mr. Smeal's drawings consist of a set of ten small sheets of miscellaneous Cairo construction details. Mr. Smeal also prepared a shipping section identification plan, utilizing Mr. Geoghegan's earlier plan, which labels the major shipping sections of the Cairo hull.

B. Description of Recovery and Existing Conditions

Prior to a discussion of the current state of the Cairo, a brief review of her raising, storage in Pascagoula, and transport to Vicksburg, of current storage conditions within the park, and of the impact of these events upon the Cairo fabric will be enlightening to those unfamiliar with the project. For an in-depth account of this period in the Cairo's history, the reader should refer to Edwin C. Bearss' definitive Cairo work, Hardluck Ironclad.

1. Discovery to Vicksburg, 1956-1977

a. Operation Cairo, 1960-1964

The Cairo was virtually intact in her tomb beneath the muddy left bank of the Yazoo riverbed when discovered in 1956. The riverborne silt overburden that had filled the interior and covered the Cairo to the upper few feet of the pilothouse had done a remarkable job

of preserving the Cairo and her contents when she was sunk by a Confederate torpedo (mine) in December 1862. Survey divers found that engine valves and wheels still turned; rubber hoses were still intact; and even organic materials such as hemp tackle, leather goods, and chewing tobacco had resisted major deterioration. Multitudes of tools, equipment, and weapons were strewn within the confines of the Cairo casemates. Beneath the gun deck her holds were packed with ammunition, coal, and ship's stores. Having abandoned the sinking ironclad in considerable haste, the Cairo crew also left a vast array of personal items onboard.

Following a three-year hiatus of exploration, 1959 reconnaissance dives on the Cairo site determined conclusively that the gunboat was complete and in an apparently excellent state of preservation. The significance of the discovery of an intact, undisturbed, important Civil War vessel filled with a potentially vast repository of historic artifacts excited area residents. Lacking any official state, federal, or institutional interest in recovering either the gunboat or its artifacts, local residents took it upon themselves to further explore and if possible recover what they had discovered. For this purpose Operation Cairo, Inc., was chartered in the winter of 1959-60 by citizens of Vicksburg to undertake and oversee the Cairo work.

The sponsors of Operation Cairo felt that a grass-roots program of operation would, after the vessel or its artifacts were raised, result in governmental funding due to increased public interest. Ironically, the group's strategy of recovery first and funding later was ultimately successful, albeit after irreversible damage was done to the historic fabric. The Mississippians' persistent interest in the Cairo did result in the federal government, through the National Park Service, assuming in 1972 the financial, planning, and research obligations for displaying the forlorn ironclad at Vicksburg. Unfortunately, the work done in the interim by the well-intentioned individuals of Operation Cairo did not reflect the professional expertise necessary to surmount the natural, technological, and bureaucratic obstacles they constantly faced. The controlled, mapped, and recorded recovery of ship parts and artifacts during four years of work at the Cairo site did not occur, thus

setting the stage for what many consider to have been a major archeological disaster.

By the time the U.S. Congress had appropriated sufficient funds to allow the Park Service to begin restoration and stabilization work on the Cairo, the deterioration of the ship was exceedingly advanced. The decayed fragments and pieces of gunboat that have survived to this day are a tragic reminder of a well-intentioned project that was conceived and executed without an adequate understanding of the need for funding guarantees that would ensure a professional program.

This lamentable situation has had one beneficial side effect: The disastrous experience of the Cairo recovery has helped prevent a similar fate from befalling the sunken Civil War ironclads U.S.S. Tecumseh and U.S.S. Monitor.

Operation Cairo's economic and technical problems negated the possibility of state-of-the-art nautical archeological work. Contemporary Scandinavian work on the Wasa and Roskilde boats pioneered nautical preservation techniques, and that technology could easily have been applied to the Cairo recovery project. However, with the Cairo the traditional dichotomy between the concerns of the nautical archeologist and the goals of the marine salvor were resolved in favor of the latter. Operation Cairo personnel were undoubtedly aware of the Scandinavian recovery projects but seemed to have forced themselves into a position of foregoing the careful planning, study, analysis, and documentation typical of the two foreign projects by their well-meant assumption and belief that an engineering feat somehow would bring the ship to the surface intact.

Aided by two decades of hindsight, it is readily apparent why Operation Cairo was never really able to accomplish a successful recovery effort. Blinded because of the complete lack of visibility beneath the Yazoo surface, volunteer sport divers had to do the initial survey work by touch. In 1960, the existing records of the

construction and tonnage of the city series warships were extremely sketchy. River currents, submerged log piles, and fluctuating water levels all increased the difficulty of nonprofessionals assessing the best method of raising the gunboat.

b. Cairo Raising, 1960-1964

As the sixties began, Operation Cairo's enterprising businessmen, buffs, and other assorted local volunteers began their activities at the Cairo site in earnest. Although earlier site dives had resulted in the recovery of several spikes and some pilothouse port flaps (which have since disappeared), a September 1960 dive began the recovery of many significant objects.

First to be raised was a gun port, winched from its mounting on an inclined casemate. In a sense, this rather primitive removal of the gun port would foreshadow the salvage efforts by Operation Cairo over the next four years.

The next two items to surface were the pilothouse (figure 1) and an 8-inch naval cannon. Both were initially recovered intact, but the pilothouse is now in pieces, part of the tragic succession of broken and twisted objects from the Cairo's piecemeal recovery. Like those that were to follow, these objects received insufficient documentation, possibly some haphazard preservation treatment, and certainly nothing near adequate storage.

Between 1960 and 1964, most hurricane deck planking, car lines, skylight assemblies, and possibly some related hurricane deck hardware were removed and discarded by Operation Cairo personnel, whose primary interest seemed to be in the recovery of artifacts.

In 1963, recovery efforts for the main structure of the gunboat resumed with an unsuccessful attempt to lift the Cairo based on a Jackson, Mississippi, engineering firm's recommended technique. Apparently no damage was done to the submerged craft.



Figure 1: The pilothouse as it appeared immediately after removal from the hurricane deck in September 1960. Allowed to deteriorate since this photo, now only the armor sheathing survives. Mississippi Agricultural and Industry Board photo.

Undaunted by the 1963 failure, a newly reorganized Operation Cairo steering committee secured funding for a second salvage attempt scheduled for the summer of 1964. With the promise of \$40,000 from the Warren County Board of Supervisors after the Cairo was recovered, the steering committee immediately contracted with a Louisiana salvor for recovery of the ironclad. The salvor proposed to lift the gunboat from the riverbed using six 3-inch cables that were to be drawn under the vessel's hull bottom. Then, three large barge-mounted derricks would force the gunboat to the surface (figure 2). Regrettably, an upcoming deadline involving loss of title to the Cairo if she was not surfaced prompted the committee into acceptance of the firm's proposal without any independent analysis of the salvage scheme's potential effect upon the Cairo fabric. It appears that the salvor's proposal was based on his experience in raising smaller iron-hulled river craft and was not developed out of any particular concern for an extremely heavy, wooden-planked national cultural resource.

What developed into a very inexpert excavation occurred not because of a lack of skill or sincerity of purpose upon any one individual's part, but really because no one possessed or sought an accurate assessment of the condition of the submerged gunboat and its underwater site. Ignorance of the ironclad's dimensional and physical aspects and the material condition of the hull increased the probability that intact recovery would not be successful.

Later events proved that the waterlogged oak hull planking did not possess the surface strength to resist the cutting force of all-too-few unspread lifting wires. The back-breaking effect of the lifting wires was exacerbated by the Cairo's flat-bottomed construction. Similar to other types of western river steamboats, the flat-bottomed gunboat had very little beam strength along the longitudinal axis of her hull. Lacking a strong beam, the Cairo hull construction was incapable of supporting the stress occasioned by the lifting pressure of the hoist cables at six points athwart the hull bottom. The additional load of the tons of mud within the Cairo's hull that was not removed prior to raising and of the increased weight of her saturated timbers provided added adverse factors in the gunboat's salvage.



Figure 2: This awesome flotilla of river salvor's mechanical might was gathered above the sunken Cairo in 1964. It might have been better utilized under the direction of a nautical archeologist. Mississippi Agricultural and Industry Board photo.

One catastrophe followed another during the raising of the Cairo. First, a section of the port side casemate collapsed while the salvors attempted to maneuver a lifting wire under the gunboat's hull. In all likelihood, the collapsing of the side casemate section and the later failure of all the casemate sides was due in part to the earlier removal of the hurricane deck planking and carlines. Next, the aft 10 to 15 feet of both port and starboard catamarans were severed from the boat by the cutting action of the stern lifting wire. Perhaps the greatest mishap befell the ironclad when the midships lifting wires, acting like wire cheese cutters, sliced so deeply into the hull that the project backers and salvor felt they had to raise the vessel in three sections. Even in a segmented recovery, none of the sections survived in any state approximating their original submerged condition.

Although the bow section was recovered relatively intact with the exception of the missing hurricane deck, the midships part of the boat was almost totally demolished when raised (figure 3). When first surfaced, the stern section fared only slightly better than the midships section. The stern, unfortunately, slipped from its lifting slings back into the river, demolishing the casemates, cabins, and wheelhouse above the gun deck level. Further damage was done to the stern section at the fantail when it was separated into port and starboard catamaran sections as it fell back into the river.

Many gunboat parts and artifacts were lost when they broke off the raised sections and then fell back into the Yazoo during the salvage. Contrary to a commonly held belief that the entire boat was salvaged, the wheelhouse, hurricane deck, large sections of the casemates and armor plate, machinery, bulkheads, gun deck, and stern fantail were either left in the river or completely obliterated in the course of the salvage operations. Many people familiar with the raising maintain that pilferage also claimed a quantity of Cairo artifacts.

c. Storage and Treatment in Pascagoula, 1965-1977

The wreckage aboard the salvage barges that docked at Vicksburg in early 1965 presented a drastically different termination to

Figure 3: This destructive handling of the midships section exemplifies the harm that can befall a historic shipwreck during recovery by non-archeologists. Mississippi Agricultural and Industry Board photo.

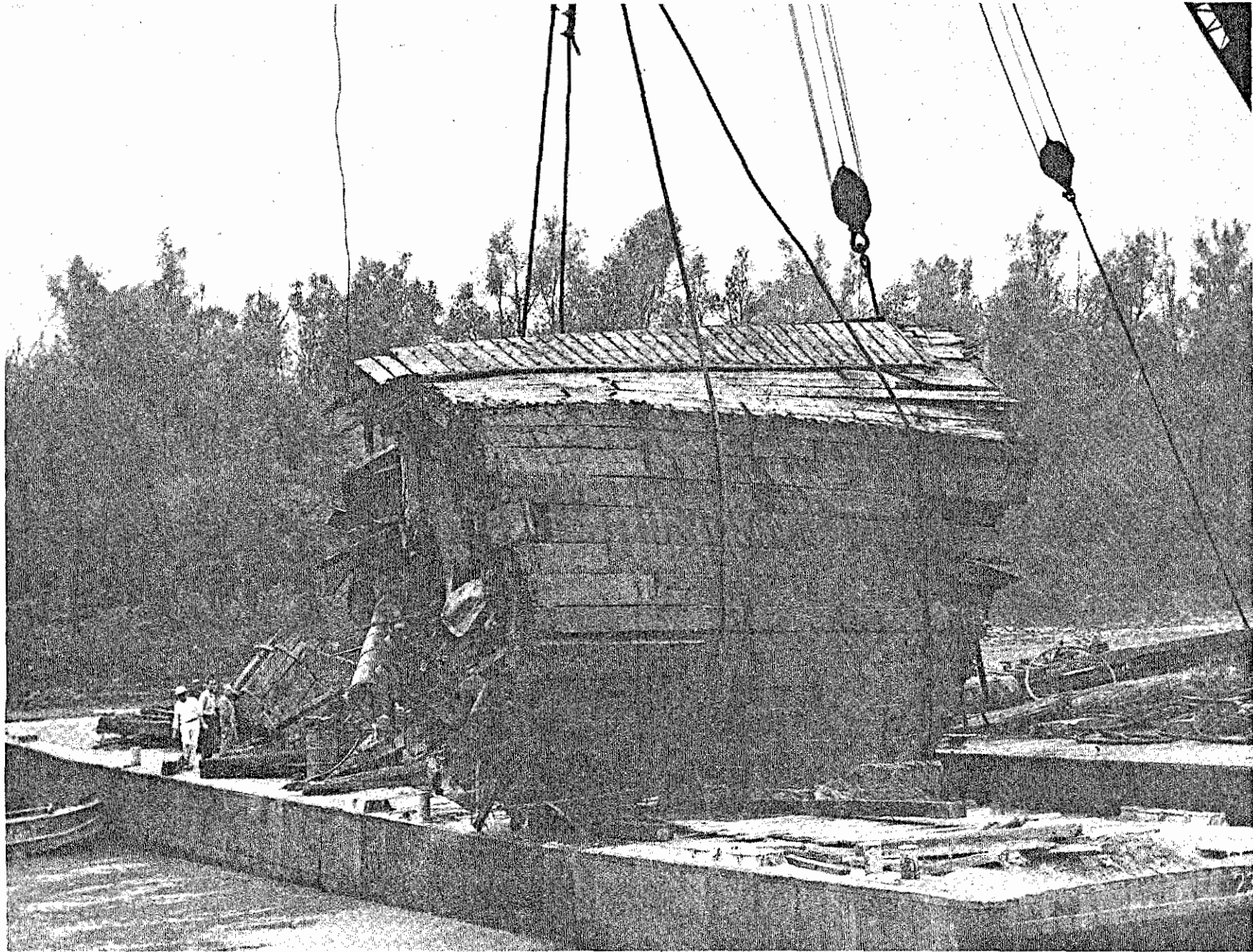

the recovery of the Cairo than most local people had envisioned (figure 4). It was apparent that for the Cairo to become the tourist attraction that Vicksburgers had anticipated, extensive reconstruction and restoration work would have to be performed on the boat. Therefore, the Mississippi Agricultural and Industry Board arranged to barge the Cairo pieces to a shipyard in Pascagoula, Mississippi, where it was hoped that the boat could be restored. After arrival in Pascagoula in 1965, the ironclad received a preliminary cleaning, partial preservation treatment for a limited number of objects (mostly iron), and temporary reassembly of all the existing wood fabric (figure 5).

The reassembly and shoring of the Cairo parts to their original positions was done by shipyard employees, not people involved with the salvage operation. This change of personnel increased the possibility of ship parts being lost or further dismantled without proper documentation because of a lack of familiarity with the ship structure. The authors' assumption on this point appears to be supported by photographs of the Cairo in Pascagoula that indicate the shipyard personnel inaccurately located a section of the starboard casemate too far forward on the reassembled gunboat.

After reassembly and cleaning, additional funding for the Cairo restoration was never allocated by the new title holder, the state of Mississippi. Ideally, conservation facilities and trained personnel should have been awaiting the Cairo in Pascagoula, but this crucial aspect of the project was neglected. The opportunity for experimentation with appropriate conservation techniques on the pilothouse, recovered four years earlier than the rest of the ironclad, was never utilized. In fact, while Operation Cairo was struggling to raise the gunboat, the pilothouse was rotting and rusting away on the Vicksburg waterfront.

No record of either a post-salvage preservation plan for the Cairo or of the few conservation measures that were taken at Pascagoula has been found. The Cairo's gun carriages and small wooden artifacts, which were left at Vicksburg National Military Park, were treated by extended immersion (less than six months) in jerry-built



Figure 4: Cairo fabric upon arrival at Pascagoula in 1965. The undocumented dismantling of many components that later magnified the difficulty of an accurate restoration had not yet begun. Mississippi Agricultural and Industry Board photo.

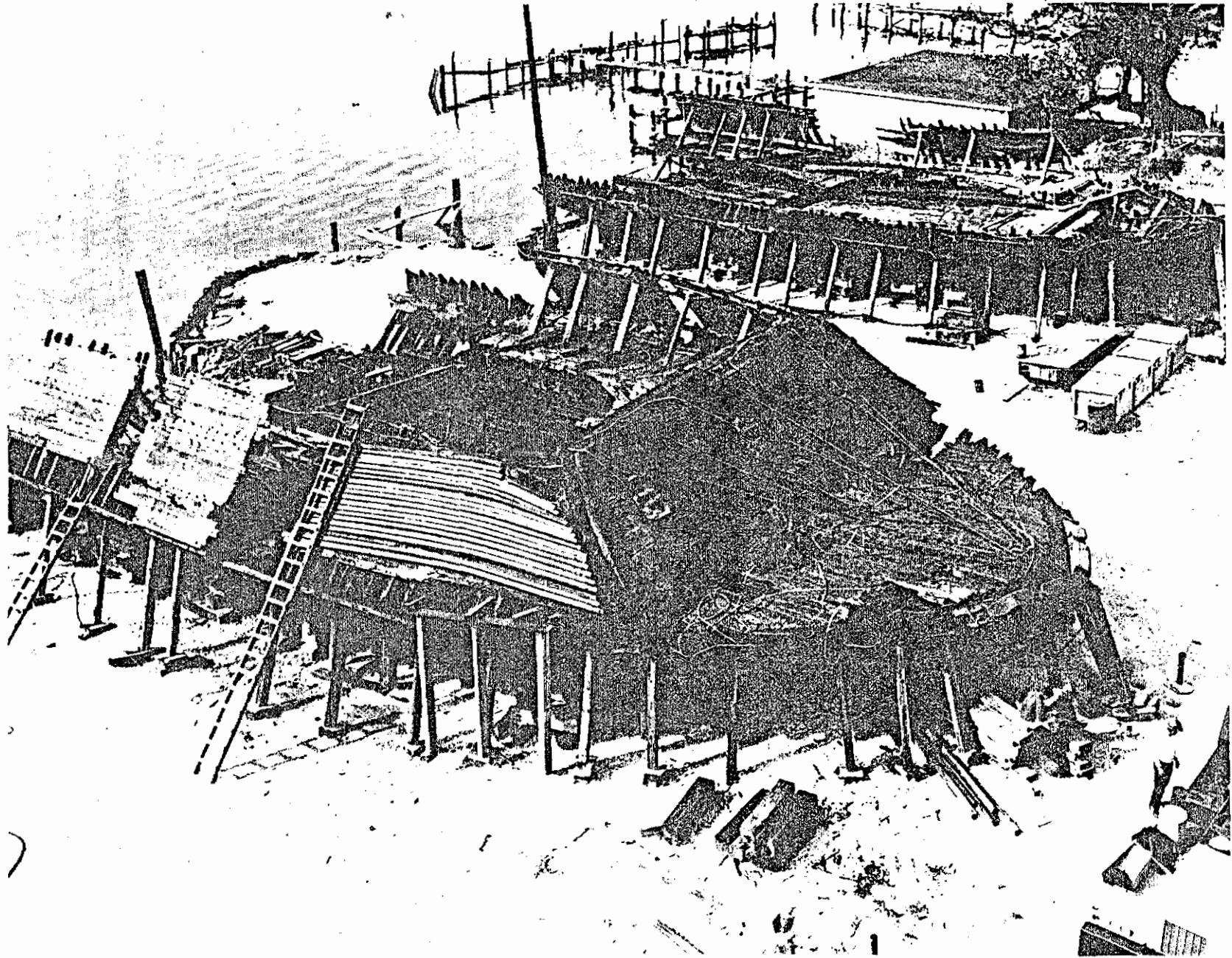

Figure 5: Cairo components after reassembly on the beach at Ingalls Shipyard in Pascagoula. Much of the historic wood fabric in this 1965 photo, particularly the side casemates and the pine decks, have completely rotted away since that time. Mississippi Agricultural and Forestry Experiment Station.

polyethylene glycol tanks. The larger wood items at the park were treated in a 25 percent polyethylene glycol solution tank with pentachlorophenol added. The smaller items were treated in two other tanks containing 40 percent and 50 percent solutions of polyethylene glycol respectively. Neither of the smaller tank solutions contained pentachlorophenol. All of the items treated at the national park have been in covered storage since their treatment in 1965 and are now quite well preserved. These treated objects demonstrate the effectiveness of even minimal preservation treatment and are all that is left to indicate the initial condition of all the Cairo fabric following the salvage.

Once a submerged wreck is brought to the surface, a critical phase in controlling the condition of the salvaged vessel begins. The Operation Cairo volunteers recognized that preservation measures were necessary, but were able to accomplish very little of what was needed for even a minimal level of stabilization. While the Cairo was submerged, biological destruction of the strength-giving material of the oak cell walls had been slight, so that the main conservation task was not reinforcement but controlled drying of the gunboat's wood fabric. As an interim measure to mitigate the change of environment caused by the salvage, the Cairo wood fabric was constantly sprayed with fresh water after the salvaged remains were brought to Pascagoula. Continuous spraying to prevent rapid drying of the ironclad's parts, begun a considerable length of time following the salvage and after the wood had assuredly become partially dried, was a questionable measure. Confusing saturating wood by spraying with water rather than submerging the fabric is, given the nature of the entire operation, perhaps excusable; however, when permanent restoration funds for the Civil War gunboat failed to materialize, the program should have been reevaluated.

The Gulf Coast proved to be an extremely unkind storage site for the U.S.S. Cairo. Far removed from those people who worked so long and hard for her recovery, the "hardluck ironclad" was easily forgotten in her isolated storage at the shipyard. The final touch in the regrettable history of the Cairo's storage in Pascagoula was the area itself. Pascagoula possesses a highly destructive combination of

sun, salt air, and moisture in its environment. Ultimately, these extremely adverse atmospheric conditions caused damage to the Cairo fabric which far exceeded any deterioration prior to the gunboat salvage and almost matched the destruction done in the course of the recovery operation.

Basically, two factors caused the loss of at least half of the wooden portions of the ironclad during the Cairo's 13 years at Pascagoula. First, the intense Gulf Coast sun had an extremely adverse, long-term destructive effect on the unsheltered wood surfaces of the gunboat. The second and more detrimental factor was the freshwater spray program. Maintenance of the spray program by the shipyard apparently was slipshod. Eventually, the alternating cycles of wetting and drying produced a rot-conducive microclimate that far exceeded the destructive capabilities of the natural surrounding area. The unbelievable aspect of the wetting of the fabric is that what began as a misguided spray program was maintained and funded past the time when parts of the shored Cairo casemates began collapsing upon themselves because their braces had either rusted or rotted away and grasses and wood-consuming fungus flourished upon the wood. Photographs of the ironclad after a decade of this sort of treatment are mute testimony to the curatorial indifference that the gunboat suffered while in storage at Pascagoula (figure 6). This treatment was terminated in the early- to mid-1970s, but the ironclad stayed at Pascagoula until 1977.

d. Transport to Vicksburg, 1977

In 1977, four years after gaining title to the Cairo from the state of Mississippi, the National Park Service contracted with a retired marine colonel to supervise moving the ironclad from Pascagoula to its present site within Vicksburg National Military Park. In the course of preparing the Cairo for transport, workers discarded unidentifiable, highly deteriorated lumber that had separated from the gunboat sections reassembled in 1965. All the wooden Cairo sections that were transported to Vicksburg were sprayed with a hydrozo/5 percent pentachlorophenol wood preservative solution before shipment.

Figure 6: The reassembled Cairo had collapsed and was rotting by the time this 1977 photo was taken in Pascagoula. Note the pieces of garden hose in the upper left. NPS photo by Jim Smeal.

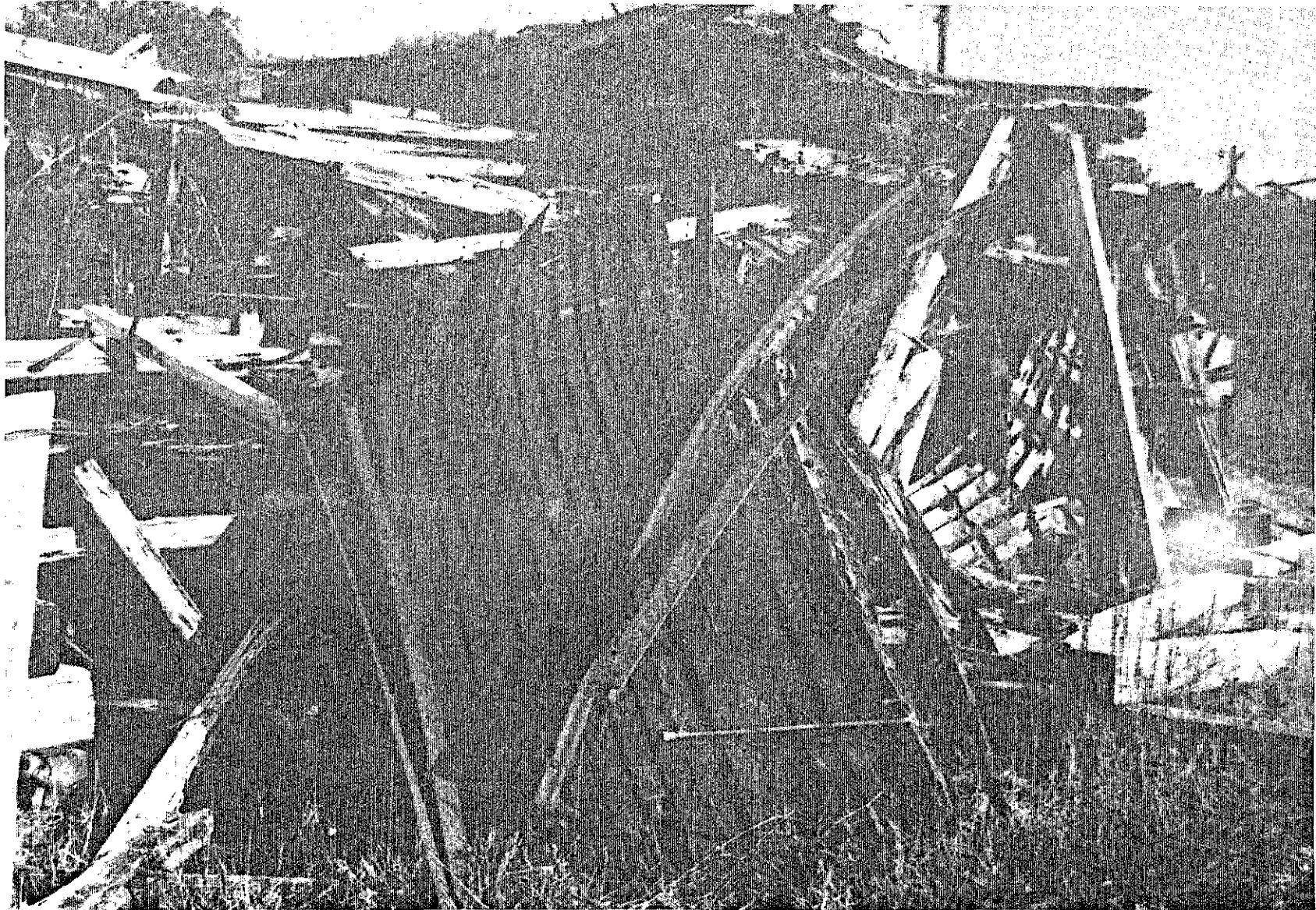

The bulk of the wooden remains of the Cairo was comprised of approximately 17 large separate wooden sections after the gunboat was set up in Pascagoula in 1965. To facilitate truck transit to the park, many of these 17 sections were further divided by chain saw into smaller sections. The bow section and the midships section in particular were divided into smaller segments for the move. By the time the Cairo arrived at Vicksburg, there were approximately 27 separate significant wooden sections. Restoration has progressed at Vicksburg since that time.

2. Description of the Cairo Complex

The overall site for the Cairo complex is described in the Administrative Data Section. A description of the display of the restored gunboat and companion structures follows (see figure 7).

a. Display Berth

The Cairo will be displayed in a reinforced concrete dry-berth foundation that is set below-grade and so that grade represents the water line. Direct support will be provided by five concrete skids which will run lengthwise beneath the ship at the keels and bilge strakes. The berth is completed.

b. Cover Structure

A 245' x 130' five-column shelter to protect the Cairo from further weathering damage was completed in 1980 (figure 8). It includes skylights, roof drainage, and lighting in its construction. The shelter design supplements the angular site scene and protects the boat without impairing views of the craft from the immediate area (figure 8).

The steel cover is allowing the Cairo timbers to achieve an air-dry condition that should inhibit further decay. Chemical preservation treatment will supplement the protective benefits of the cover by providing long-term insecticide, shrinkage protection, and water repellancy for the wooden portions of the Cairo hull. Similar cover structures successfully protect the remains of three other Civil War

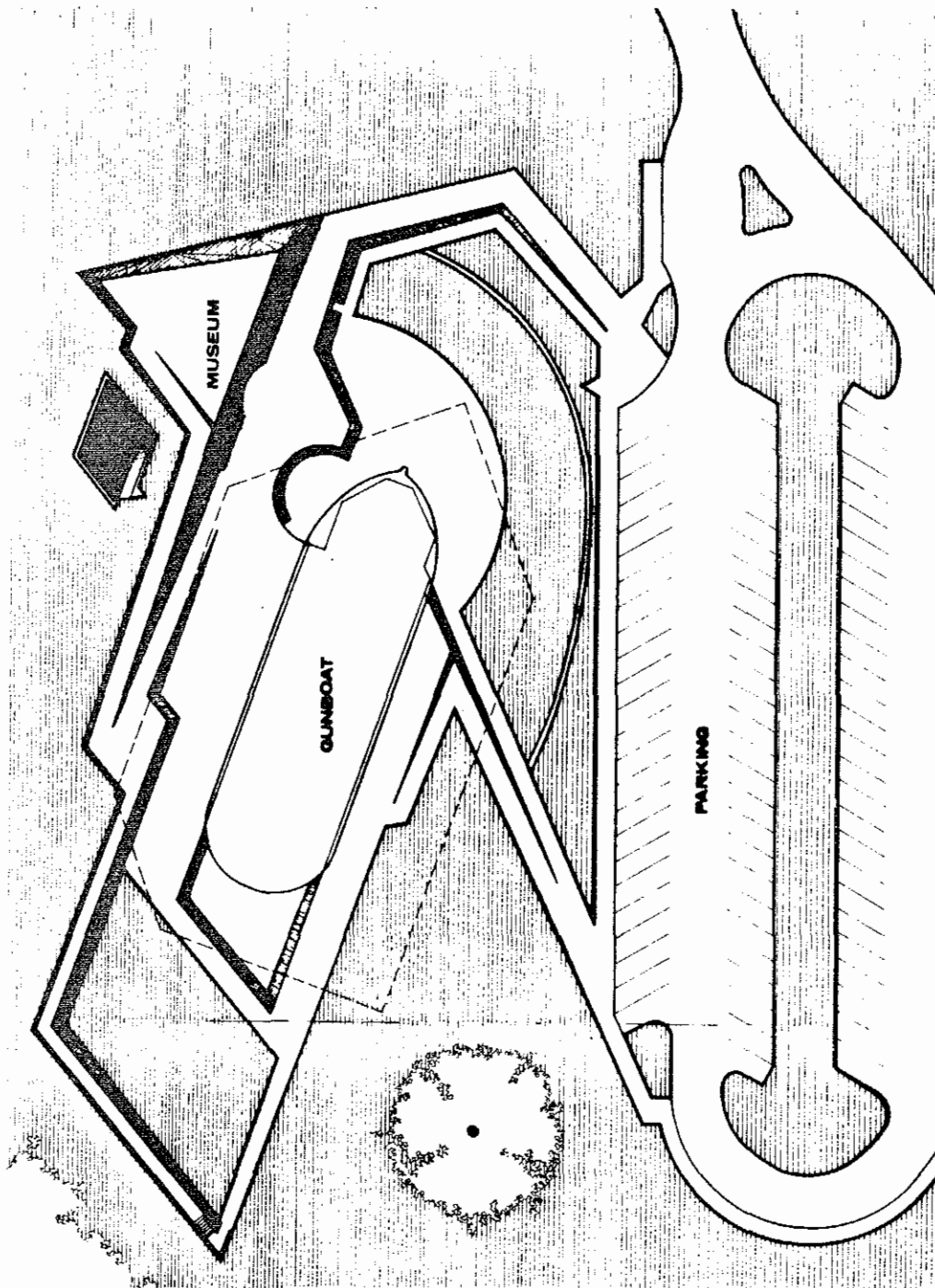

Figure 7: Site plan of the Cairo complex, showing the dry berth, museum, parking, access, and viewing ramps.

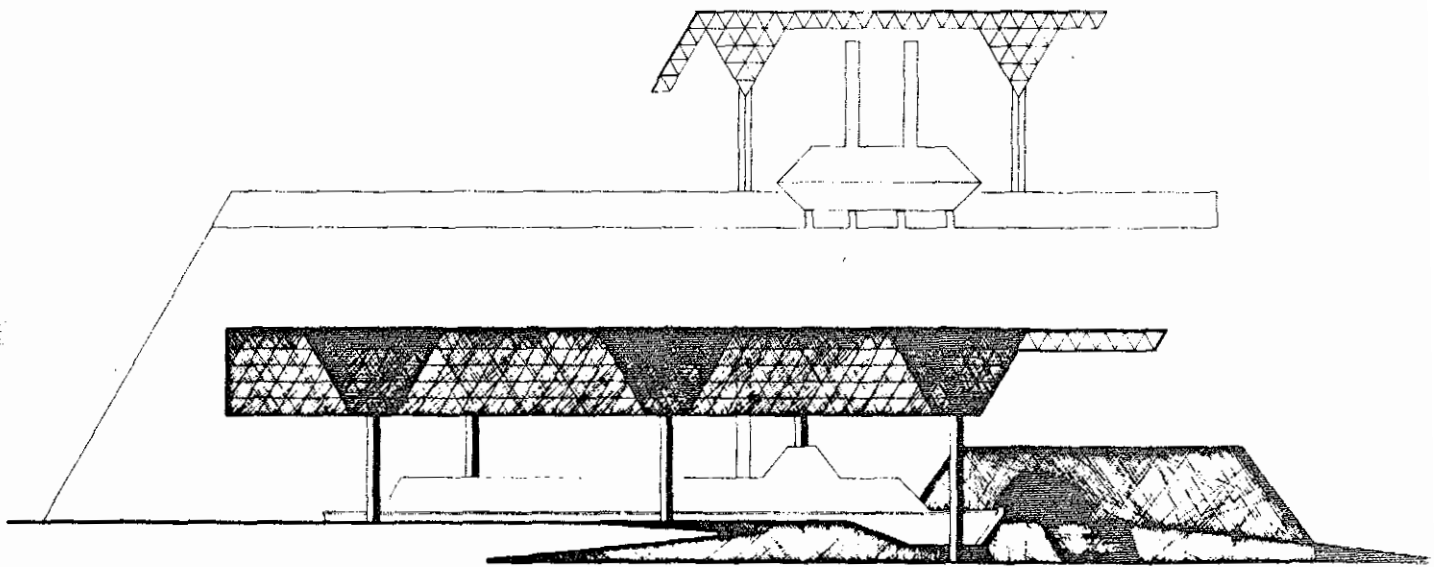

Figure 8: Section and west side elevation of the Cairo space frame cover. The entrance to the museum is on the lower right.

vessels at the C.S.S. Neuse Historic Site in Kinston, North Carolina, and the Confederate Naval Museum in Columbus, Georgia.

c. Restoration Shop

A prefabricated, temporary Cairo conservation shop and a concrete paved work apron have also been completed. Convenient to, but not visible from, the display site, the 2,400 square foot shop provides a protected work space for the Cairo preservation/restoration effort. Office, tool, equipment, and storage space are provided within the shop building.

d. Cairo Museum

The Cairo museum and visitor center is situated against a hill on the southeastern perimeter of the brick-paved terrace overlooking the port bow of the Cairo. Construction of the massive triangular museum features battered concrete walls and a bunker-like emplacement within the hillside. The formidable exterior of the structure is intended to harmonize with the displayed warship; inside, subdued lighting, running water, and wood block floors will suggest a ship's interior. Information, sales, office, curatorial, storage, and restroom facilities are located within the museum building.

The primary purpose of the museum building is for the permanent display and storage of thousands of Cairo artifacts. They are in excellent condition and will graphically depict the lives and times of the crew that manned the ironclad during the Civil War Mississippi River campaign.

3. NPS Cairo Research and Fabric Investigation

a. Historic Description of the Cairo

(1) The Development of the City Class Design

The Cairo was one of a group of Civil War gunboats of the City Class design (figure 9). A general discussion of the City Class ships will put the technical data on the Cairo in perspective.

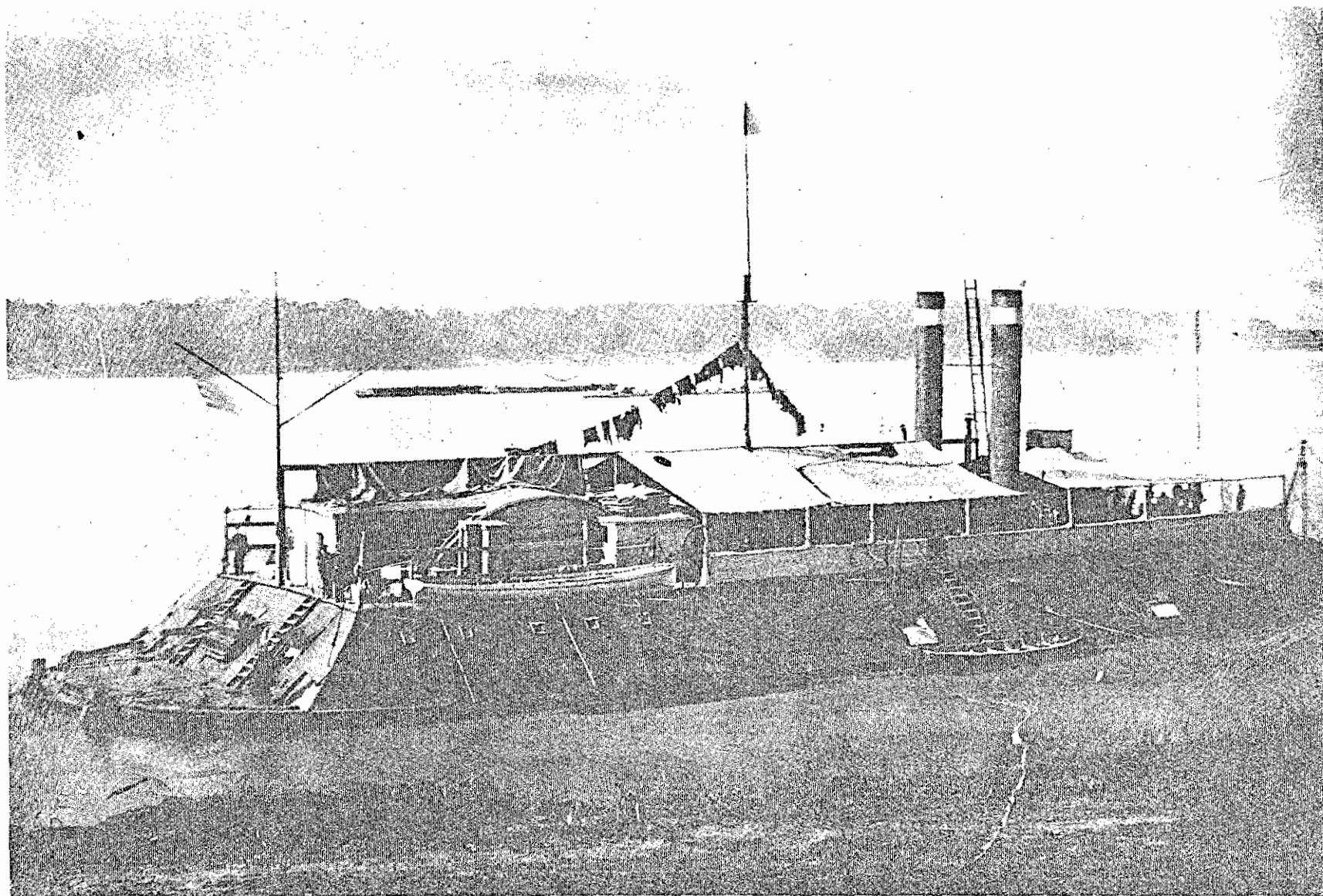

Figure 9: The U.S.S. Cincinnati, a sister ship to the Cairo, which was sunk by a Confederate ram at Plum Point. National Archives photo.

The bombardment of Fort Sumter in April 1861 sounded the prelude for rapid development and deployment of a variety of revolutionary technological and design innovations in naval propulsion, armament, and construction that not only influenced the outcome of the American Civil War but also changed the character of the entire concept of war at sea.

Although there was the potential for new ship types for several decades prior to the Civil War, developments in warship design were usually refinements of an already established ship configuration. Other than Lord Nelson's brilliant tactical strategies devised at Trafalgar in 1805, European and American naval planners were generally unaffected by the changing world around them and thus naval practice remained unaltered. However, by mid-century, advances in science fell in step with the maturing Industrial Revolution to produce an overwhelming potential for completely new ship designs. By 1865, the changes in naval warfare that had germinated a decade before the Civil War had achieved a blossom that would affect the development of the world's navies for the next 50 years.

The 1861 design of the Union City Class Mississippi squadron gunboats merged the two great naval advancements of the first half of the 19th century: steam power and iron construction. The subject of this study, the City Class vessel U.S.S. Cairo, was the first warship sunk by a submerged electronically detonated torpedo (mine) and thus is a monument to the clash of the new generation of naval weapons pioneered during the war between the states. Although preliminary European development of steam-powered iron armored vessels, largely during the Crimean War, had marked the demise of the majestic sail-powered ship-of-the-line, it was the uniquely inventive talents of the American combatants and their innovative ship designs that decisively proved the foresight of French and British ironclad builders of the 1850's.¹

1. James Phinney Baxter III, Introduction of the Ironclad Warship (Cambridge University Press, 1933), p. 140.

The primary historical significance of the Ead's gunboats is the story of their overwhelming success in the North's campaign to open the Mississippi. These seven City Class gunboats were an affirmation of the change in naval warfare, but they were rapidly rendered technologically obsolete by the introduction of the river versions of Ericsson's Monitor.

Incorporating many of the distinctive features of the western river snag boat with respect to hull design, materials, construction, and propulsion, the City Class vessels were well suited to the swift and shallow rivers of the Mississippi basin. Naval architect Samuel M. Pook's empirical design drawing for the City Class gunboat combined available Northern-manufactured materials and industrial skills. Undoubtedly influenced by the French floating batteries Devestation, Lave, and Tonnante used so successfully at Kinburn Kosa, Pook's design was nonetheless innovative and original.

American proposals for armored vessels with inclined sides date from the War of 1812.² The first steam-powered warship, "The Steam Battery," built by Robert Fulton in 1814 pioneered the same type recessed paddle wheel alignment that Pook's design was to incorporate. With respect to the all-timber construction of the City Class gunboat, the warships seem to have been constructed according to riverboat-building principles long since established on the Mississippi

2. Ibid., p. 9.

(figures 10 and 11). The James B. Eads-constructed City Class gunboats, then, are best summarized as brilliant improvisational river theater hybrids of the typical twin hulled snag boat which combined Mississippi River practice, Yankee ingenuity, and the industrial materials and machines of an emerging technological society to meet the uncompromising demands of war.

(2) Technical and Descriptive Data on the Historic Cairo

The following data was compiled by the personnel of the Ingalls Shipbuilding Corporation of Pascagoula, Mississippi, in August 1965, and has been slightly revised and corrected based on NPS research for this report. For a further historic description of the Cairo's framing, materials, fastenings, etc., the reader should refer to "Specifications For Building a Gunboat" in appendix A.

General

Type: ironclad river gunboat
Class: City Class
Number of vessels in class: seven
Area of operations: lower Mississippi River

Principal Characteristics

Overall length : 175'
Breadth: ±52'
Full load keel draft: 6'
Displacement, full load, FW: 888 tons
Tonnage: 512
Number of hull compartments: 15
Speed: 6 knots
Estimated built-weight of wood hull and casemate: 350 tons
Hull form: flat bottom, knuckle bilge
Number of keels: 3
Paddlewheel arrangement: recessed wheel
Decks: 3 (boiler deck, gun deck, hurricane deck)
Frame timbers and hull planking and ceiling: white oak
Deck planking: white pine
Ship's boats: 3 cutter, 1 launch
Anchors: 2 forward
Rudder arrangement: 2 stern-post hung
Hurricane deck awning arrangement: stanchion mounted

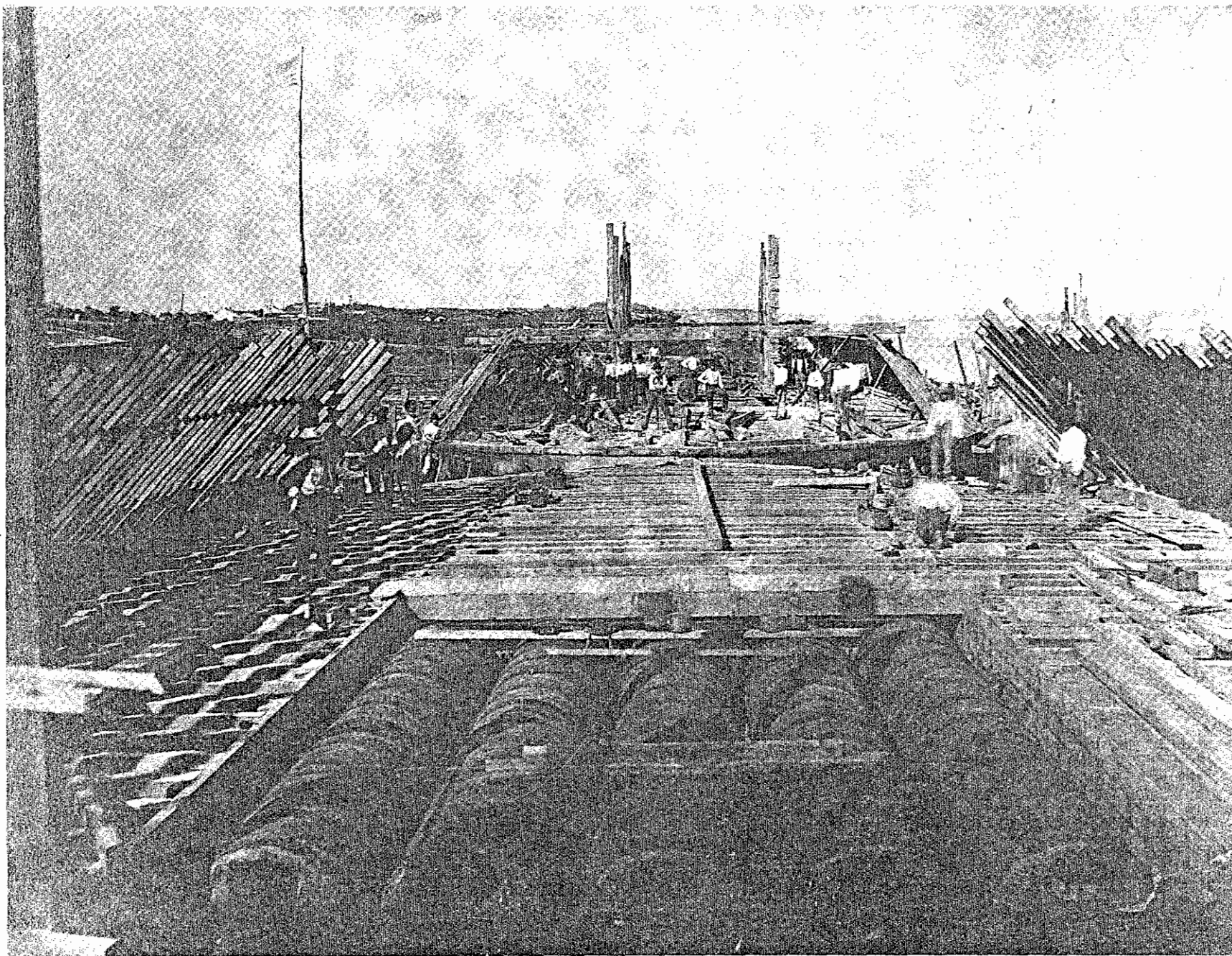
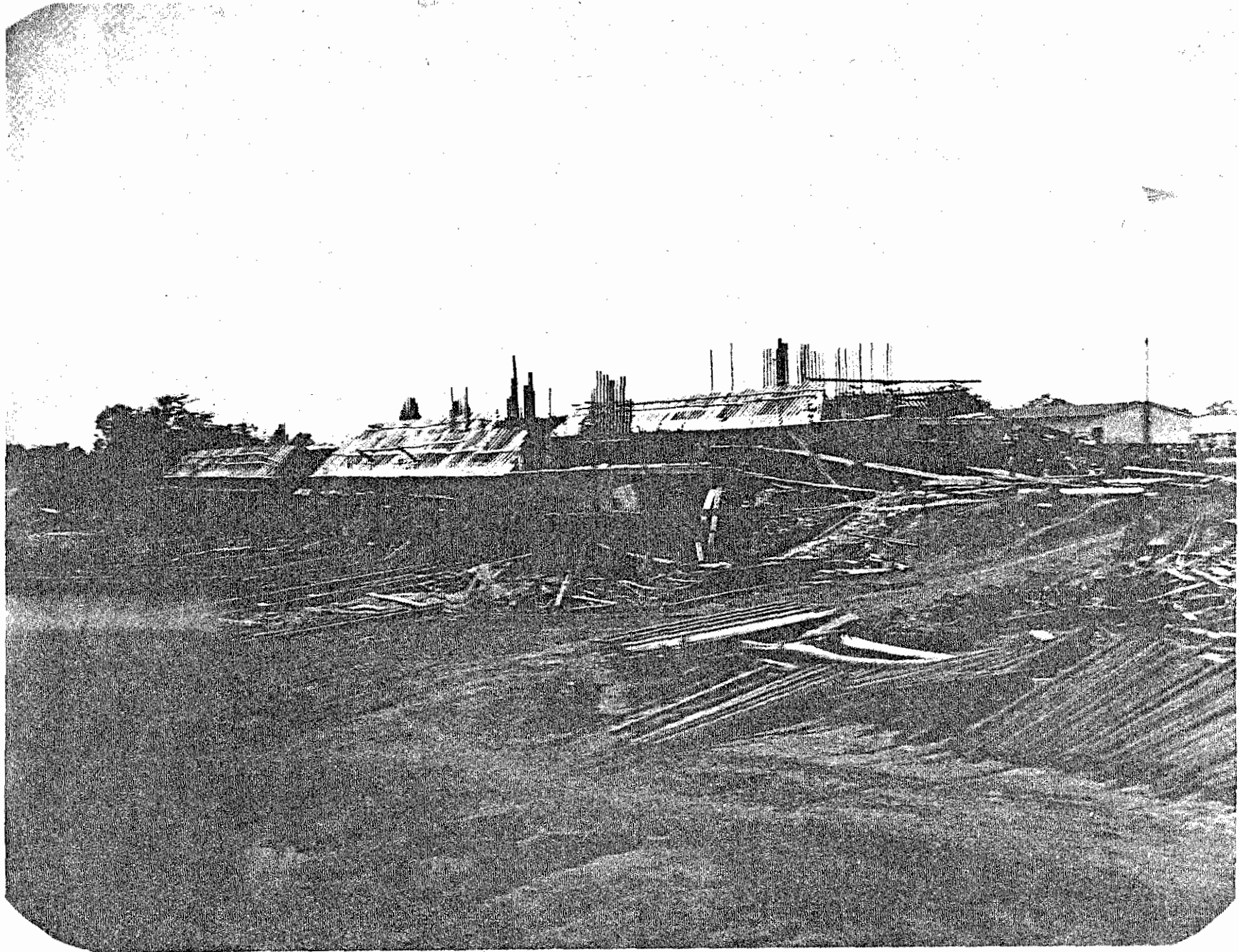

Figure 10: Gunboats under construction, built bow to bow. The five boilers are in place on the vessel in the foreground. National Archives photo.

Figure 11: Two City Class gunboats on the shipways at the yard in Carondelet, Missouri. National Archives photo.



Accommodations: captain's cabin (aft of the waterway), 8 officer's cabins (4 cabins port and starboard), medicine room (port)

Armament

Three 7-inch bore 42-pounder army rifles
Three 8-inch 64-pounders, 63 cwt navy smoothbores
Six 32-pounders, 42 cwt navy smoothbores
One 30-pounder Parrott rifle, navy
One 12-pounder boat howitzer (removed November 1862 by USN)

Bow ports: 3
Side ports: 4 each side
Stern ports: 2
Note: See appendix D for tabulation of Cairo armament location and markings

Armor

Thickness of plate armor: 2 1/2"
Designed weight of plate armor: 75 tons
Weight of plate armor added by changes: 47 tons
Total weight of plate armor: 122 tons
Plate armor material: charcoal iron
Armor plate sizes: 13" wide x 2' 5" to 8' 1 1/2" long
Wood backing for armor on three front panels of pilothouse: 19 1/2"
Wood backing for armor on five sides and back panels of pilot-house: 12"
Casemate side inclination: 45°
Casemate end inclination: 45°
Thickness of casemate timbers and sheathing: 25" forward, 12 1/2" port, starboard, and aft
Location of plate armor: forward casemate and side casemates athwart engine machinery and pilothouse
Railroad iron armor: 3 1/2" iron rails from the forward-most side gun port to the front casemate, both port and starboard

Machinery

Type: reciprocating steam--noncondensing
Number of engines: 2
Cylinder size: 22" diameter x 72" stroke
Cylinder inclination: 15°
Piston rods: 4" diameter x 110" long
Paddle wheel diameter: 22'
Paddle wheel deck opening: 28' x 18'
Type: return flue
Number of boilers: 5
Boiler size: 36" diameter x 24' long
Smoke stacks: 3'6" diameter twin abreast--28' high

Fuel: coal
 Boiler pressure: 140 lbs./sq. in.
 Fuel consumption per hour: 18 to 20 bushels, 1980 lbs./0.885 tons
 Auxiliary Machinery
 Steam driven capstan
 Steam driven pumps
 Hand pumps
 Feedwater steam engine ("Doctor")

Paint Colors

Exterior: black
 Interior: whitewashed
 Smoke stacks: colored bands for identification
 (Cairo colors - light grey)

Complement

Officers	17
Petty officers	27
Seamen	111
Landsmen	3
Apprentices	1
Firemen	12
Coal heavers	<u>4</u>
Total Complement	175
Enlisted men:	158
Officers:	17

Historic Cost Data

Contract price for each of seven boats	\$ 89,600
Average cost of changes	<u>\$ 12,208</u>
Total average cost	\$101,808
Uniforms and clothing for crew	\$ 6,430
Small stores	\$ 1,142
Ground tackle, hawes, hammocks, bags, coal, engineer's and carpenter's stores	\$ 7,150

Carpenter's wages--\$2.00 per 10 hour day
 Carpenter's overtime wages--\$0.25 per hour

Hulls built by 600 men using wood from 7 sawmills

Names

Designer: Samuel M. Pook, Naval Constructor, USN

Contractor: James B. Eads

Engine Designer: A.T. Merritt, Cincinnati, Ohio

Hull Builders: Hambleton, Collier and Co., Mound City, Illinois,
3 hulls

The Carondelet Marine Railway and Drydock Co.,
Carondelet, Missouri, 4 hulls

Engine and Boiler Builders:

Hartuppee and Co., Pittsburgh, Pennsylvania, 2 sets of machinery

Eagle Foundry, St. Louis, Missouri, 5 sets of machinery

Fulton Foundry, St. Louis, Missouri

Armor Plate Manufacturer: Gaylord, Son and Co., Portsmouth,
Ohio and Newport, Kentucky

Gun Carriage and Ordinance Implement Manufacturers:

Eagle Iron Works, Cincinnati, Ohio

Owner: United States Army, later United States Navy
(October 1, 1862)

Owner's Representative: (Q.M. Gen.) Montgomery C. Meigs, USA

Commanders: Lt. James M. Pritchett, USN

Lt. Nathaniel Bryant, USN

Lt. Comdr. Thomas O. Selfridge, USN

Places

Building Sites: Mound City, Illinois, for Cairo, Cincinnati,
Mound City

Carondelet, Missouri, for St. Louis (later
Baron de Kalb), Louisville, Pittsburgh,
Carondelet

Cairo's Namesake: Cairo, Illinois

(3) Discussion of the Historic Propulsion System

Paddle Wheel

The Cairo employed a recess wheel.³ This type of paddle wheel alignment is similar to the well-known stern wheel. The Cairo recessed wheel was located within the protected raceway, between the casemates to protect it from enemy fire. Five paddle wheel spiders, made of iron arms and circles, were attached to flanges built around an iron shaft driven at either end by cranks mounted at 90° to each other. This entire shaft assembly was in turn supported both port and starboard by bearings mounted on massive triangular-shaped timber paddle wheel blocks. The paddle wheel buckets were most likely made of uniform width wood and could have easily been replaced when damaged. The wheel was probably balanced by doubling the thickness of the bucket planks opposite the cranks.

Connecting Gear

The iron and wood pitman arms served as the connecting rods between the steam driven engines and both paddle shaft cranks. The Cairo pitman arms were constructed with iron straps on both top and bottom, bolted through the center wooden member. Two iron full-stroke and cut-off cam rods connected the two cam frames to the engine valve gear on both port and starboard.

3. William D. Sawyer, "The Western River Engine," Steamboat Bill 14 (Summer 1948):76.

Engine

The two inclined, one-cylinder Cairo steam engines were controlled separately. By manipulation of the camrods by means of lifters, or "hooks," the engineer could control the forward, starting out, and reverse turn of the paddle wheel.

Steam entered the engine cylinder from a steam pipe that passed through a throttle to the steam valve. After driving the piston, the used steam was vented out the exhaust valve to the water preheater, where the heat of the steam was transferred to the boiler feedwater before exhausting via the "scape pipe" to the stacks.⁴ The Cairo also possessed an ingenious system of venting steam to the wheelhouse where it provided winter heat for the prevention of icing on the paddle wheel.

Two aspects of the Cairo steam engines allowed a certain degree of distortion of the engine components; due to an intentionally flexible hull structure, without damaging the equipment: (1) the lever valve gear previously discussed, and (2) extra clearance within the ends of the cylinder called "dunnage," which prevented the piston from striking the cylinder heads due to "working the hull."⁵

Auxiliary Engine

The auxiliary engine, or "doctor" (so named because it cured the ills of the steamboat), pumped feed water to the boilers, thereby maintaining a safe water level within them by means of pressurized supply. Although

4. Ibid., p. 77.

5. Alan Bates, The Western Rivers Steamboat Cyclopoedum or American Riverboat Structure and Detail, Salted with Lore with a Nod to the Modelmaker (Leonia, New Jersey: Hustle Press, 1968), p. 96.

the Cairo doctor was lost during her salvage, traditional river practice would place this small steam-powered beam engine aft of the boilers between the engines.⁶

Steam Drum, Boilers, and Mud Drum

The five Cairo boilers produced steam from the heat transferred through their respective flues to the water in the boilers surrounding the flues. The boiler firebox with its brick lining was located under the forward section of each cylindrical boiler. It supplied the hot gasses which ran aft from the firebox, under the boilers, and to the aft flue mouths, all the while contained within the boiler casing. The gasses then reversed direction, drawn forward within the flue pipe by the natural draft of the tall stacks, where the smoke was then vented.

The boilers were joined in their after section by a steam drum mounted laterally above them. The steam drum served as a collector and manifold and was connected to both engines and the steam-driven capstan and doctor by steam lines. The mud drum both supported the boilers and collected the sediment of the pumped feed water drained through the boiler bottoms. Periodically the mud drum was cleaned by blow down pipes that passed through the hull bottom.⁷

(4) Discussion of Historic Armor

Original Armor

The City Class gunboats were conceived and designed as forward fighting vessels and consequently were most heavily protected at the forward casemate. American and European armor experiments conducted prior to

6. Sawyer, "The Western River Engine," p. 80.

7. Ibid., p. 79.

and at the commencement of the Civil War determined that the most effective shield against cannon fire was an inclined surface of a thick laminated-oak backing sheathed by iron plate. The Cairo's armor protection was similar to the systems developed before the war and was typical of casemated wood and iron naval armor of the mid-century conflict.

Weight restrictions caused by the shallow draft requirements for the western rivers prevented sheathing the entire casemated surface of the City Class vessels. The octagonal pilothouse was protected with iron plate for obvious reasons. The only other area of the City Class gunboats protected by an armor belt installed prior to commissioning were the casemate and hull sides athwart the boilers and engines.

During the Civil War the use of shot-proof iron plate was an innovation of immediate tactical importance to vessels thus shielded, but it did not guarantee invulnerability. The City Class gunboats were wooden ships with wood decks, and so were particularly susceptible to plunging fire. The upperworks, stacks, wheelhouse, and unarmored casemate sections could be and were damaged by enemy shells, and as the Cairo was the first to prove, the gunboats were vulnerable to the newly developed rebel torpedo (mine).

Supplemental Historic Armor

After the Cairo was commissioned, the captain requested that railroad iron be placed on the ship as additional armor. It was placed laterally along the entire height of both port and starboard casemate abaft the front casemate and afore the first side casemate gun port.

b. Discussion of Hull Structure

The Cairo was typical of river steamers of the day in her extreme length in proportion to her depth and in that she was

flat-bottomed.⁸ Because such vessels did not have the stabilizing "beam effect" of deep-hulled craft, their typical reaction to the stresses caused by loading and movement was to "hog," or have the ends drop and the midships rise.⁹ To compensate for this, a hull-bracing system for flat-bottomed boats based on "hog chains" was developed in the 1840s.

Hog chains utilized a system of iron tension rods called chains, which ran from bow to stern and were supported by poles called braces. The braces were placed amidships on the keelsons and ran through the upper decking and works of the steamship. The chains prevented the bow and stern from dropping and the braces prevented the midships section from raising.

Constructed to withstand inward hydrostatic pressure and unevenly spaced hydrodynamic loads, the Cairo's historic timber framework and hog bracing combined to form a complex tension and compression structure designed to interact with the surrounding water pressure.¹⁰ Afloat, the hydrostatic pressure of the water placed the hull frame and deck beams in compression. When a riverboat is out of the water, local and overall loads shift, hydrostatic pressure is removed, and the compression members are put in tension; thus, the entire structure is stressed in a manner inconsistent with its intended design and use. The glue-laminated hull support framework proposed for the Cairo approximates the even support of the water, similar to the blocks and shores used when a ship is in dry dock or on its construction ways.

8. Bates, Steamboat Cyclopoedium, p. 24.

9. Ibid.

10. "The Monitor, Its Meaning and Future," 1978, Papers from a National Conference, The Preservation Press.

c. The Cairo Research Model and "As Built" Cairo Drawings

In March 1977 the interdisciplinary NPS Cairo project team, recognizing the unusual preservation problems inherent in the decaying and broken ironclad components, decided that careful construction of an exact large-scale research model of the Cairo was the best way to both conduct the necessary fabric investigation and formulate a guide for management decisions on the project. Choosing a research model as the vehicle for the Cairo fabric investigation was a unique departure from the normal methods of Park Service historic structure investigation and, as such, warrants further discussion (figure 12).

Although the use of admiralty, dockyard, and builder's half-models is well documented over the last four centuries, the use of construction models in shipbuilding has been largely supplanted this century by drafted plans. The increased development of maritime museums over the past three decades has been accompanied by increased scholarly use of interpretive and reconstruction models of historic ship types. The benefits to researchers in the field of maritime preservation include the easily discernable ship configuration, arrangement, and construction method that a scale model imparts. The Cairo project is the most extensive and ambitious ship preservation project in this country that has been guided almost completely by decisions made based on a research model (figure 13).

This approach was also developed to combat problems caused by the frequent turnover of individuals responsible for work with the Cairo historic fabric. Recognizing the time-consuming investigation required for sufficient familiarity with the vast assortment of ship components, a 1976 "Boat Restoration Study" commissioned by the Park Service recommended that a chief conservator be found to guide all the Cairo work, from transit to final display. Park Service management instead adopted a team approach to the gunboat project. In addition, it was decided to contract the preparation and shipment of the boat to Vicksburg. This resulted, after the departure of the transit staff, in a loss of first-hand knowledge of the Cairo's Pascagoula condition and

Figure 12: The Cairo research model, placed within a scaled model of the dry berth, provides a view of the completed gunboat restoration plan. NPS photo by Les Siroky.

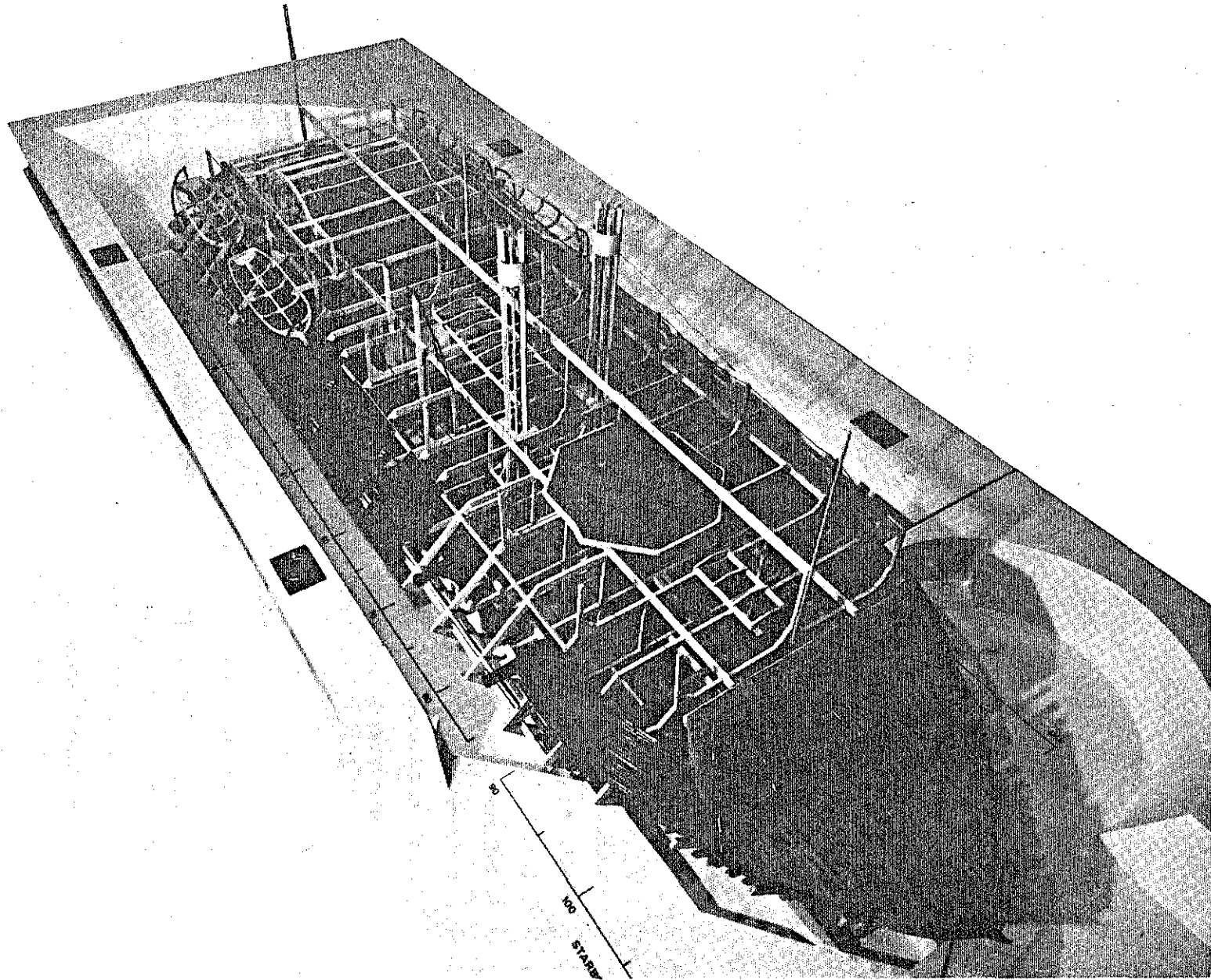

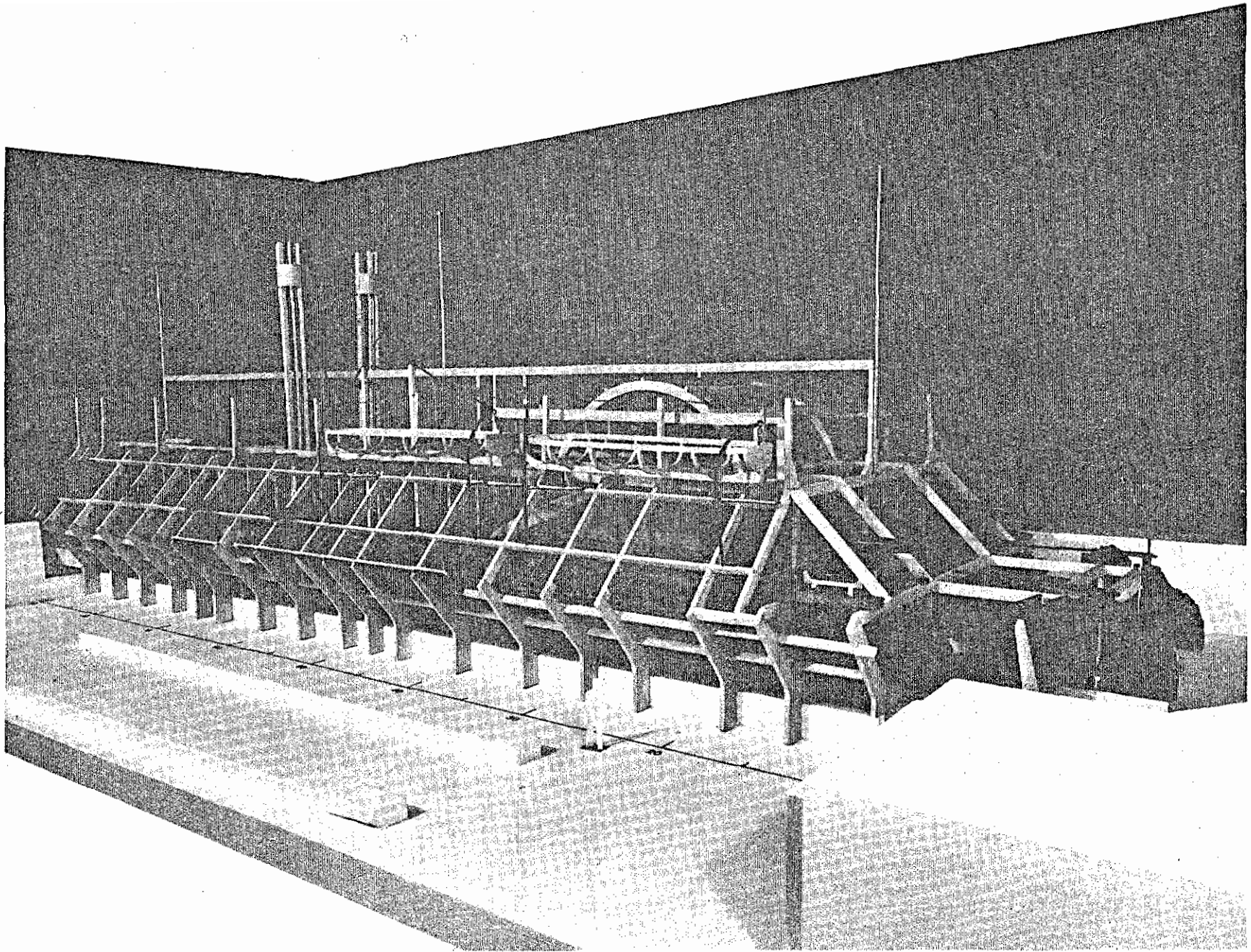

Figure 13: The scale torpedo (mine) blast hole in the port bow is evident in this photo of the model. Modelmaking was helpful in solving the oft-conflicting requirements of engineering, interpretive, and preservation problems that faced the architects. NPS photo by Les Siroky.

accompanying clues to the ironclad's original construction. The decision to build the Cairo research model permitted documentation of the ship's construction and identification of individual components, lessening the problems associated with continuing deterioration and changes in team membership.

The construction of the $\frac{1}{2}$ ":1' scale Cairo model was based on copious field notes, historic and raising/reassembly photographs, and onsite observations, practices all common to a traditional historic resource fabric investigation. The notes, measurements, and sketches of the gunboat fabric have been compiled into as-built drawings, included in this report in appendix I. Important as these drawings are, they are intended to supplement the data amassed in the ironclad model, for it is only in the three-dimensional scale model form that one can conceptualize the structural condition, construction, and appearance of the disassembled Civil War vessel (figure 14).

Upon completion in April 1979, the Cairo model provided the project architects and engineers with a comprehensive design tool from which nine restoration alternatives and associated costs were developed. Following preliminary management approval of alternative E, the proposed structural support and "ghosting" of missing areas were incorporated into the model (figure 15). This modeling process allowed the project designers and engineers to detect errors and reveal problems prior to any actual construction. In addition, the now-complete model of the structural system and the ghosting will provide both an accurate guide for the restoration's project supervisor work and interim interpretation for the public during the work.

d. 1980 Status/Current Fabric Condition

Two major problems consistently plagued the Cairo restoration effort. A description of them has bearing on the ship's current status.

The first, changing personnel, was mitigated by the construction of the model, as described in section c.

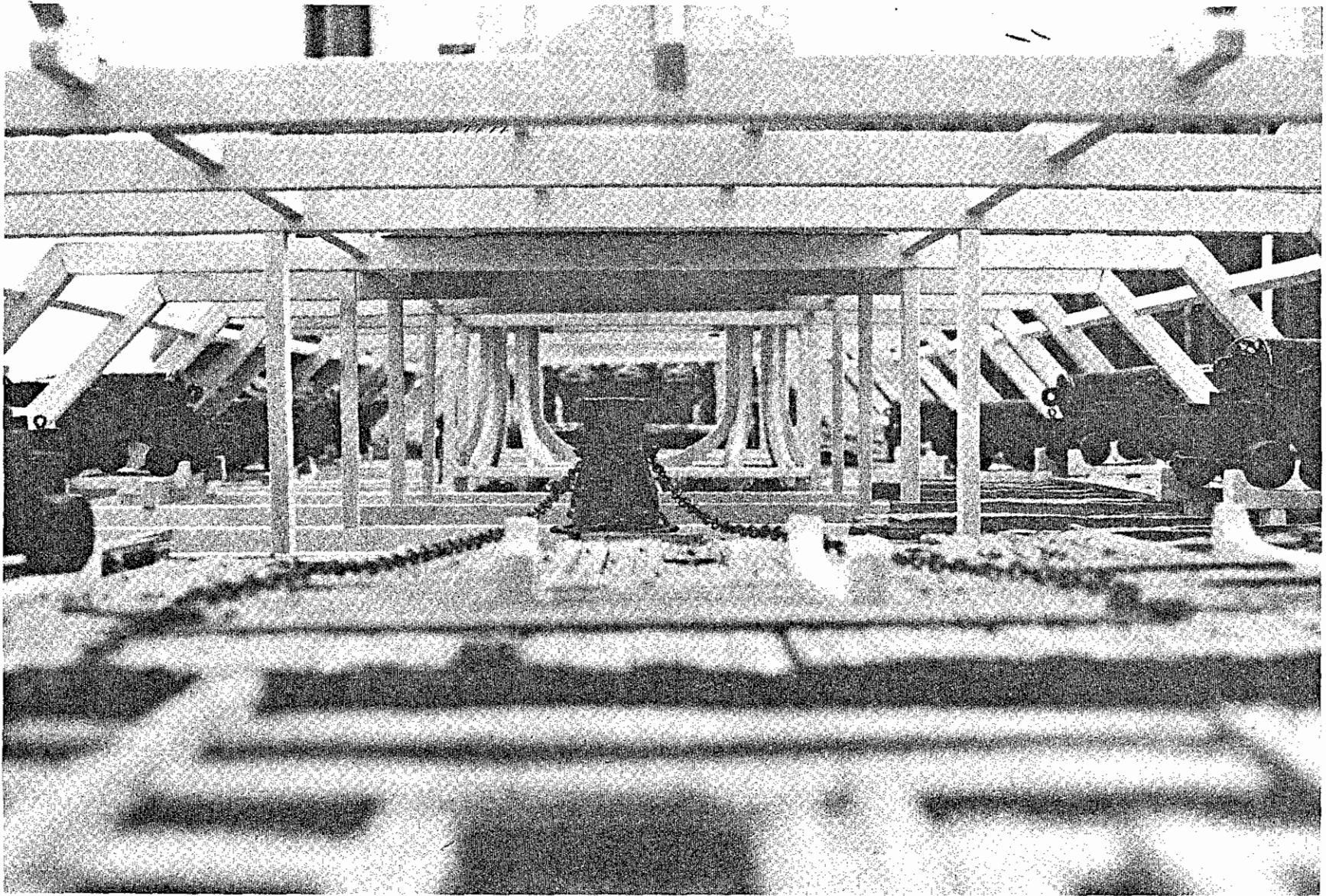
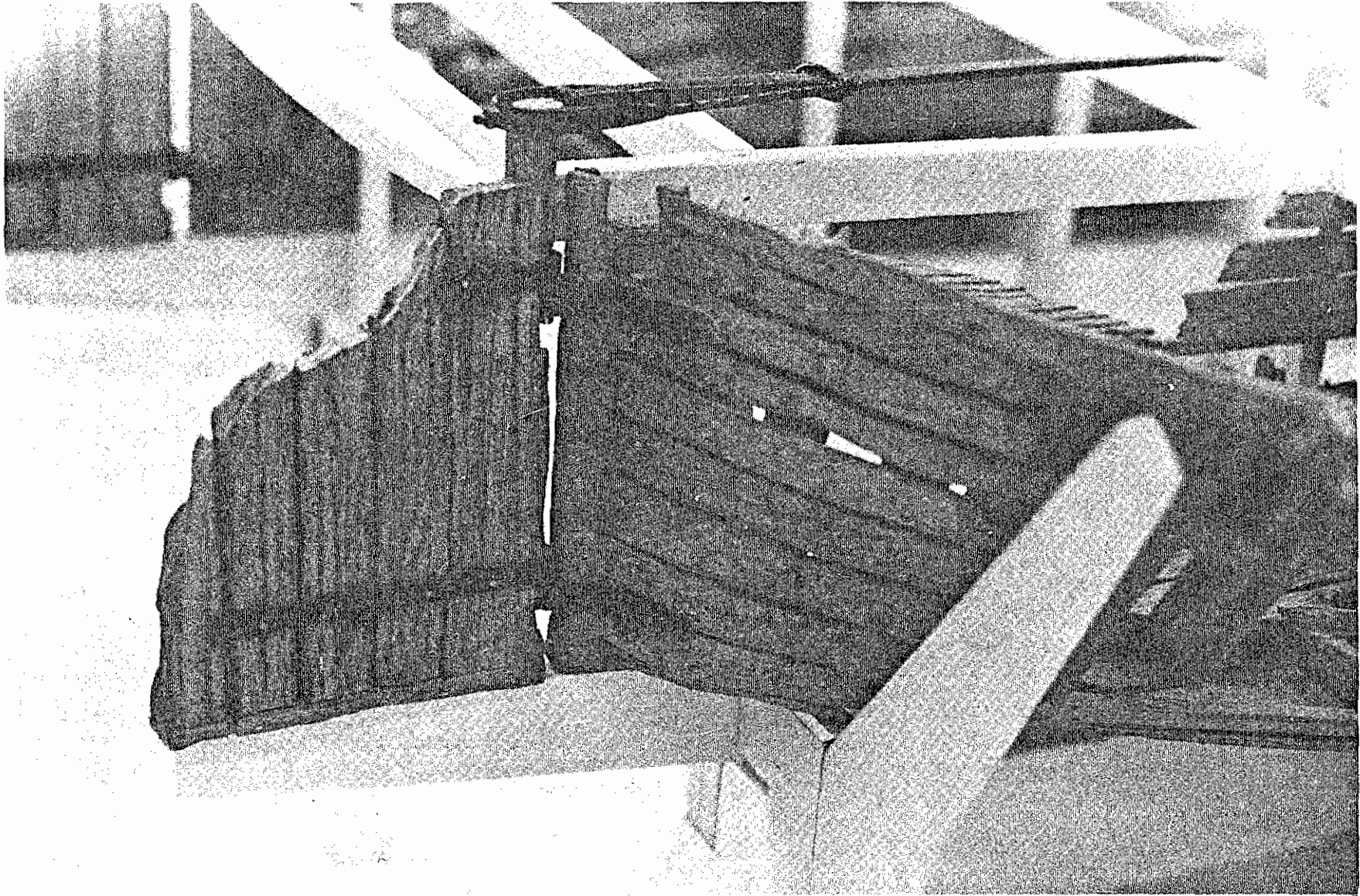

Figure 14: Interior view of the Cairo model, looking aft, simulates the eventual visitor's perspective. NPS photo by Doulgas Ashley.

Figure 15: Detail of the modeled sternpost section and rudder, supported by the scaled version of the specially designed glue-laminated structure. NPS photo by Douglas Ashley.



The second has been a change in the display plan for the Cairo. In 1977, at the time of transit, NPS plans were to reconstruct the Cairo, so the shippers sectionalized the hull in a manner that would ease transit. Unfortunately, this was not the most desirable method in terms of the final selected alternative, which calls for restoration instead of reconstruction. An example of how this affected the project is the forward casemate, which was assumed to be beyond restoration in 1977 and thus was divided into four parts for use as a pattern piece in the presumed reconstruction.

Therefore, when active stabilization work began in 1980, a team whose knowledge was based on extensive fabric investigation and of the model was faced with saving severely deteriorated and sometimes broken or unidentifiable fabric. The ironclad sections that had been brought to Vicksburg in spring of 1977 had continued to suffer from the elements. The toxic effects of the preshipping pentachlorophenol treatment were so diminished by the leeching action of the Mississippi rains that grasses, fungus, and insect life began to return to the ironclad remains in 1979. Ship parts not stored within the completed concrete display berth required constant maintenance just to keep the wood free of weed growth and construction debris.

Long-term stabilization of the Cairo began in 1979 with specific treatment for each degenerative ill that afflicted the surviving historic gunboat fabric. The following discussion characterizes the conditions that affected the Cairo at the time stabilization efforts began.

(1) Wood Fabric

The heartwood of white oak is a grayish brown, and the sapwood is nearly white. With age, the pores of the heartwood of white oak can become plugged by a growth known as tyloses. These plugs tend to make the wood impenetrable to liquids. For this reason, white oak has traditionally been the ideal choice for ship planks, frames, and all types of cooperage work. Heartwood oak is preferred over sapwood because of its superior decay resistance.

The bulk of the remaining Cairo fabric is white oak lumber that is essentially sound, with most biological damage confined to considerable surface decay. There is some chemical decay and significant weathering. The deep checks in most members are usually the result of repeated wet/dry cycles. These checks can present serious preservation problems where they have allowed moisture to penetrate to the timber center, thereby causing internal pockets of decay.

The 1980 shelter structure combined with a chemical preservation program can undoubtedly stabilize the Cairo's wood fabric. The timbers are affected by several conditions.

(a) Biological Decay

Wood kept constantly dry resists decay, as does wood kept continuously submerged in an anaerobic freshwater environment (such as the Cairo had been until its recovery). Bacteria and certain soft rot fungi can attach submerged wood, but the resulting deterioration is extremely slow. Cellular material in wood submerged for extended periods tends to leach away, resulting in a tremendous loss of strength with little change in physical appearance.

Moisture and temperature, which vary greatly with local conditions, are the principal factors affecting the rate of biological decay in wood exposed to the elements. Serious decay occurs only when the moisture content of the wood is above the fiber saturation level (average 30 percent). Only in cases such as the Cairo, where previously dried wood contacts water, such as rain, condensation, or wet ground, will the saturation point be reached. Water vapor in humid air alone will not wet wood sufficiently to support massive decay.

Fully air-dried wood usually will have a moisture content from 15 percent to 20 percent (depending on temperature and humidity) and should provide a margin of safety against fungus growth. Previous fungus or bacteria infections will not progress if the wood is dry and protected from moisture penetration.

Three kinds of wood decay are easily recognized: brown rot, white rot, and soft rot. These different types of fungi require air, food, moisture, and favorable temperature for growth. Deprived of the above conditions for fungus growth, wood can be prevented from rotting almost indefinitely.

(b) Chemical Decay

Chemical solutions can affect Cairo wood by two general types of action: the first is an almost completely reversible swelling of the wood; the second type is irreversible and involves permanent degenerative changes in the wood structure.

Iron salts, which develop at points of contact between wood, bolts, spikes, and the like, have an irreversible degradative action on wood, especially in the presence of moisture. The oxide layer formed on iron objects is transformed through a chemical reaction with wood acids into soluble iron salts which degrade the wood surrounding the iron. In addition, iron salts can precipitate toxic extractives from the wood and thus lower the natural resistance of wood to decay. The discoloration and softening of lumber around corroded iron fastenings is common; it becomes especially pronounced in acid woods, such as oak, which contain tannin and related compounds.

(c) Weathering

Without protective treatment, freshly cut wood exposed to the weather will change materially in color. Other changes to exposed lumber include warping, loss of surface fibers, and surface roughening and checking.

In the weathering process, wood degradation is influenced greatly by the wave-length of light; the most severe degradation is produced by exposure to the ultraviolet rays of the sun. As cycles of wetting and drying repeatedly occur, most exposed woods develop visible physical changes such as checks or cracks. Moderate- to low-density woods will acquire fewer checks than high-density woods, such as the Cairo's oak, in the weathering process.

d. Moisture-Related Dimensional Changes

Cut lumber is dimensionally stable when the moisture content is at the fiber saturation point of 30 percent. Wood changes dimensionally as it gains or loses moisture, shrinking when losing moisture and swelling when gaining moisture. Continued swelling and contraction causes warping, checking, and splitting in unseasoned green timber.

The practical objective of all wood handling and preservation should be to minimize moisture content changes. Favored procedures are those that bring the wood to a moisture content in equilibrium with the average atmospheric conditions. Dry wood undergoes small fluctuations in dimension with normal changes in relative humidity. These changes, however, are considerably less severe than dimensional changes caused by direct wet/dry cycles in wood.

Wood is usually exposed to both long-term and short-term changes in humidity and temperature. Thus, wood virtually always is undergoing at least slight changes in moisture content.

On March 9, 1979, NPS historical architects Tom McGrath and Doug Ashley performed a series of moisture content readings on the existing fabric of the U.S.S. Cairo. These readings were taken randomly over the existing historic wood fabric of the vessel and portray a representative sample of the moisture content of the vessel's timbers. Prior to the day of the tests, the ship had not been wetted by rain for a period of six days. The test utilized a Delmhorst Instrument Company. Moisture Detector, Model RC-1B. Compared against the more accurate dry weight moisture content testing of five core samples of Cairo timbers conducted in January 1977 (see appendix C), the following readings indicate that the surface areas of the gunboat timbers have dried somewhat in the last two years.

The results indicated that the vessel was rotting and that the situation would persist as long as the fabric was exposed to rain wetting (causing an average moisture content of over 25 percent). The

shelter completed in 1980 will control this problem. The 1979 moisture readings were:

<u>Frame 110</u>	
Bottom breast	65%+
Pine gun deck	22%
<u>Frame 105</u>	
Center keelson	42%
Ceiling (port)	24%
Gundeck beam	50%
<u>Frame 97</u>	
Frame member	65%
<u>Frame 96</u>	
Center keelson	65%+
Port keelson	38%
<u>Frame 81</u>	
Ceiling	25%
Frame member	65%+
<u>Frame 67</u>	
Frame member	12%
<u>Frame 65</u>	
Frame member	65%+
Port gun deck shelf	30%
PORT CATAMARAN	
<u>Frame 54</u>	
Engine block	12%
<u>Frame 49</u>	
Engine block (pine)	20.5%
Frame member	45%
Gun deck beam	64%+
<u>Frame 27</u>	
Paddle wheel block (pine)	12%
<u>Frame 25</u>	
Decking	35%
<u>Frame 20</u>	
Bildge keelson	12%
Frame member	12%
<u>Frame 18</u>	
Gun deck beam	29%
STARBOARD CATAMARAN	
<u>Frame 45</u>	
Engine block	12%
Gun deck beam	12%
Ceiling	44%
<u>Frame 42</u>	
Frame member	31%
<u>Frame 20</u>	
Frame member	65%+

<u>Frame 21</u>	
Pine decking	40%
Gun deck beam	12%
<u>Frame 23</u>	
Bilge keelson	25%
Ceiling	65%+

(2) Metal Fabric

Oxidation or rust is the overwhelming problem which must be faced in any metal preservation program. Although extremely slow, rust is a highly destructive process to metal fabric. In any successful preservation effort rust must be either stabilized or removed from the metal that is to be preserved. Moisture either within the layers of rust or in the atmosphere will cause an ongoing process of oxidation that is then followed by exfoliation, the eventual result being the conversion of metallic iron into iron oxide.

Iron free of chlorides is normally easily stabilized. Harpers Ferry Center laboratory analysis has revealed no evidence of chlorides in the Cairo ferrous metals. There should be no special problems in removing the moderate corrosion covering the metal fabric of the Cairo.

The most important factor in the successful long-term stabilization of iron objects is the maintenance of a protective preservative coating. As long as the coating remains free of dents, scarring, or abrasion the preservation treatment will remain effective. The proposed smooth black surface coating for the Cairo iron will minimize the adverse visual effect of a sealer coat over the metal objects while at the same time marking those objects immediately as being original historic fabric (metal fabric preservation option II).

(3) Cairo Structural Integrity

(a) Historic Gunboat Framework

The integral body of the Cairo framework was irrevocably fragmented at the time of her salvage. However, most of the individual recovered sections did retain varying degrees of structural

unity. Restoration of these components, with a minimum of new internal bracing, was an alternative considered in the years immediately following the ironclad's raising. However, 15 years of neglect and decay have reduced most recovered sections to frail assemblages of wood fabric that in most cases will not support their own dead loads. With the exception of most sections of hull bottom, the structural integrity of the surviving gunboat timber parts is highly questionable.

(b) Pascagoula Reassembly Support Remains

The crew at Ingalls shipyard positioned ½-inch wire tension cables across the Cairo reassembly to support the forward and side casemates in their original positions. At the same time, 3" x 3" angle iron frames were installed within both port and starboard catamaran sections. Wood blocks and shores propped the rest of the Cairo hull and surviving timber fabric.

The wire support cables had disintegrated by 1977, leaving only a scattering of anchor bolts as evidence of their existence. The wooden shoring was totally removed when the Cairo was cleaned before transport to Vicksburg. Only the substantially weakened, heavily exfoliating internal catamaran angle-iron frames now remain onboard the Cairo.

The long-term results of both the cable and steel angle supports have been adverse to the current ship preservation effort. The wire cables' anchor-bolt holes make identification of historic construction evidence confusing. Chemical degradation of wood abutting the rusting steel catamaran frames is notable and will be difficult to stabilize.

(c) Transport Structure

The crates, pallets, and steel and plywood shipping frames that now surround or support most Cairo sections were not intended as long-term supports. The wooden crates and pallets are so obviously impermanent that they deserve no further discussion.

The steel and plywood hull supports within the concrete tub are discussed in this report only as one alternative support system for the permanent display of the Cairo. However, besides the undesirable aesthetic and safety problems of the present temporary hull support system, it is also detrimental to fabric preservation because the plywood sheathing between the steel frames and hull planking retains moisture and inhibits ventilation.

e. Technical Alternatives for Treatment

This section describes the technical stabilization and preservation measures that are possible in such a project. For each type of fabric, a series of treatment alternatives follows a discussion of the state of the art. These technical alternatives are followed by section C, "Cairo Restoration Program Alternatives," which presents a series of restoration program proposals that incorporate a variety of the techniques described in this section.

(1) Wood Preservation

The shrinkage, warping, and checking of the Cairo timbers cannot be corrected short of actual replacement and it would be fruitless to attempt to remedy the extensive deterioration of the wood surfaces, so these types of actions will not occur. Rather, a program realistically aimed at preserving and displaying the fabric, rather than correcting major deficiencies, is planned. Following such treatment, curatorial vigilance and periodic retreatment will be necessary. The following discussion characterizes some of the potential preservation treatments.

(a) Types of Wood Preservatives

(i) Oilborne Fungicides

(aa) Creosote

Constituents: tar acids, tar bases, and acridines composed of numerous active components that render the treated lumber resistant against almost all types of wood-destroying bacteria and fungi.

Characteristics: black, oily, petroleum color
Application: Pressure retort
Penetration: 1/4" to 4"
Typical life: 30 years
Finishes: cannot be finished (painted)
Toxicity: toxic to touch, skin and eye irritant

(bb) Pentachlorophenol

Constituents: methylene chloride, light solvents, LPG systems,
blended petroleum solvents or water repellents
Characteristics: brown, generally clear
Application: penetration:
 pressure retort 1/4" to 4"
 thermal 1" to 2"
 brush-on 1/16" to 1/8"
Typical life: pressure retort, thermal--30 years; brush-on--10
years
Finishes: range from non-paintability (heavy oil solvents) to
indistinguishable in change (LPG)
Toxicity: highly toxic to breath and touch

(cc) Tributyltin oxide

Constituents: organotin, petroleum solvents
Characteristics: staining; clear and various colors; easier to use
than pentachlorophenol; less toxic; inexpensive
Application: brush-on
Penetration: 1/16" to 1/8"
Typical life: 10 years
Finishes: paintable
Toxicity: skin irritant

(ii) Waterborne Preservatives

(aa) CZC (Chromated Zinc Chloride

Constituents: zinc chloride and sodium dichromate
Characteristics: Corrosive to metal fasteners; greenish tinge fading
to natural; possible warping; checking or weathering
Application: pressure retort
Penetration: 1/4" to 4"
Typical life: 30 years
Finishes: clean and paintable
Toxicity: harmful to swallow

(bb) FCAP (Fluoro-chrome-arsenic-phenol)

Constituents: multi-salt preservative
Characteristics: protects out-of-ground timber, not sufficiently
insoluble for in-ground long-term protection; yellow staining,
using dinitrophenol; greenish tinge
Application: pressure retort
Penetration: 1/4" to 4"
Typical life: 30 years
Finishes: clean and paintable
Toxicity: harmful to swallow, skin and eye irritant

(cc) CCA (Chromated Copper Arsenate), Type A, B, and C

Constituents: salts or oxides
Characteristics: greenish tinge; high permanance; possible fire hazard
Application: pressure retort
Penetration: 1/4" to 4"
Typical life: 50 years
Finishes: clean and paintable
Toxicity: harmful to swallow, skin and eye irritant

(dd) ACA (Ammoniacal Copper Arsenite)

Constituents: copper hydroxide, arsenic trioxide, acetic acid and ammonia
Characteristics: fire hazards; possible warping and checking; greenish staining; possible leaching of copper
Application: pressure retort
Penetration: 1/4" to 4"
Typical life: 30 years
Finishes: clean and paintable
Toxicity: skin and eye irritant; harmful to swallow

(ee) ACC (Acid Cupric Chromate)

Constituents: liquid-copper carbonate and chromic acid
Characteristics: reduced slugging; possible warping and checking
greenish tinge
Application: pressure retort
Typical life: 30 years
Finishes: clean and paintable
Toxicity: skin and eye irritant

(b) Application of Preservatives

Wood preserving methods are of two general types: nonpressure processes, which vary widely in method and are generally less effective in penetration and retention of preservatives than the pressure methods, and pressure processes, in which the wood is impregnated in closed vessels under pressures considerably above normal.

Nothing short of completely dismantling the existing fabric of the Cairo will allow for the use of any pressure process now commercially available. Even if the dismantling were completed, the effectiveness of the pressure treatment would eventually wane and a retreatment would be necessary. This would entail another dismantling. A pressure application method is out of the question financially and would cause irreversible damage to the integrity of the historic craftsmanship.

The most simple nonpressure application is by brush or spray nozzle. Other nonpressure methods such as soaking or steeping in solutions, diffusion processes with waterborne preservatives, thermal bath processes, vacuum treatments, etc., are available but require dismantling of the fabric.

(c) Wood Fabric Preservation Options

During the Cairo's 100 years submersion, the natural wood saps and resins were leached from the wood surface areas. This did not, however, severely affect the appearance of the timbers. When the Cairo was raised, the bulk of the vessel parts were in like-new condition. Upon removal from the water, their surface areas dried rapidly and began shrinking and separating from the solid interiors.

Now, each time they are wetted, these lifeless surface fibers wash away or become saturated, depending on the extent of decay. The fibers swell with wetting and when the sun returns, the moisture evaporates and the surface areas shrink. This continual leaching and movement has been responsible for most deep checks in the Cairo wood fabric. These checks, which reach to the center of many members, allow water deep into each timber. In fact, some members that are apparently dry on the surface have been found to contain large percentages of moisture within the interior.

If the ongoing surface movement caused by periodic wet/dry cycles were allowed to continue, the existing fabric of the Cairo would not survive. Impregnation with a consolidating and penetration chemical treatment is a necessary first step in stabilization. Even though it is protected by the cover structure, the wood will continue to shrink as it dries, but eventually it should stabilize.

The following options for wood preservative treatment were selected as the most likely applicable of many that were evaluated. An analysis of each is included as a guide for selection.

(i) Option 1 - Wood Fume

Chemical Composition: Vapor, e.g., wood fume (sodium N-methyldithiocarbonate).

Method of application: Soil fumigants were developed in the early 1950s to prepare seedbeds that would be free of insects and of fungus. Following ground insertion, the fumigants dissipate rapidly in the soil. However, when used in wood, it is several years before dissipation occurs.

Fumigants should offer deep travel, no color change, and low material cost. Basically, these fumigants are fluids which turn to a gas over a period of time. Application is achieved through bored holes that are filled with the chemical and then plugged with wooden corks. The fluid, when changed to gas, is forced by increased pressure into the surrounding wood. The bored holes should be 1/2", be 1' apart, and be drilled at 45° angle.

The advantages of using the fumigant method of wood preservation are a deep penetration and very little change in appearance of the fabric. The anticipated penetration could be anywhere from 1' to 3', depending on the wood species, but this is significantly greater than the 24" maximum anticipated with other nonpressure methods.

Anticipated adverse effects: The most glaring adverse effect is in the method of application. The drilling of holes and the subsequent plugging would definitely produce visual intrusion on the fabric. Also care must be taken during the application to prevent eye and skin contact with the preservative. Goggles, gloves, and breathers must be worn. One variety marketed under the trade name Timber Fume is a cousin to tear gas and is dangerous during application. However, these fumigants do not present a toxic hazard after the application process.

Man-hours for initial application:

Boring of holes	500
Application of chemical	200
Plugging of holes	<u>500</u>
Total man-hours	1,200

Maintenance schedule: The anticipated retreatment cycle would be 8 to 10 years. The same holes drilled for the initial application could be reused for subsequent treatments. Constant visual surveying of the fabric for problem areas is necessary.

Informational source:

Professor Robert Graham
Department of Forest Products
Forestry Research Laboratory
Oregon State University, Oregon

(ii) Option II - Hydrozo Penta

Chemical composition:

Hydrozo clear water repellent	95%
Pentachlorophenol	5%

Hydrozo is a modified oil material making a mineral gum in formula with a volatile thinner.

Method of application: Application can be accomplished with a standard 3-gallon garden-type tank sprayer. The surfaces should be clean and dry, and temperature should be between 60° and 80°F.

Application is normally achieved with a good wetting action but does not require flooding. The chemical should be allowed to dry for 24 hours and then a second coat should be applied.

A hydrozo solution should leave no glossy surface, will not retard the natural aging process, and will not discolor the wood surfaces. This preservative is also resistant to sunlight and will virtually eliminate moisture infiltration.

Before application, all loose materials, dirt, sand, loose wood, and compost should be removed. This could be accomplished by a pressure wash with warm water to blow all loose materials from within the ship, taking care to clean deep cracks and crevices thoroughly.

Anticipated adverse effects: The hydrozo alternative may be inadequate in displacing moisture as the wood dries (after the cover is completed). The penetrative qualities are acceptable, but actual data on the replacement qualities to prevent shrinkage are unknown. Adverse effects in other areas like visual distortion, etc., are not anticipated.

A fire hazard exists during application due to the thinning vehicle used.

Man-hours for initial application:

Cleaning	500
Initial application of hydrozo	100
Second application	<u>50</u>
Total man hours	650

Maintenance schedule: The treatment should be repeated on an eight-to-ten year cycle. The poor condition of the remaining wood fabric will justify sporadic spot retreatment.

Information source: This alternative was chosen for study because hydrozo has already been applied to the Cairo fabric. Col. Robert Calland and Jim Smeal applied this treatment in early 1977 prior to the relocation of the Cairo to Vicksburg NMP. For additional information contact:

P.L. Salussolia
Hydrozo Products, Co.
Eastern Sales Division
P.O. Box 1381
Myrtle Beach, SC 29577

Note: A variation of this composition is also recommended by the Forest Service.

(III) Option III - Linseed Oil/Penta

Chemical composition:

Linseed oil
Pentachlorophenol (40%)
Mineral spirits

Method of application: Preliminary cleaning will be needed as in option II, followed by three separate spray applications with approximately ten days between them.

First Application -	45% linseed oil 45% mineral spirits 10% pentachlorophenol (40%)
Second Application -	45% linseed oil 45% mineral spirits 10% pentachlorophenol (40%)
Third Application -	100% linseed oil

After allowing two months for maximum evaporation/penetration, two coats of wood sealer should be applied to stop any future bleeding of the linseed oil.

Sealer Application - Wood sealer 6-10 75%
Mineral spirits 25%

Anticipated adverse effects: During the application process, a fire hazard is present because of the use of mineral spirits as a diluting agent.

The application of this solution will undoubtedly cause a major darkening of the wood. When treatment samples are completed, we will know this option's exact effect on white oak. The pine used to construct the Confederate ram Neuse turned almost black when this treatment was applied to the displayed vessel. Another problem may be caused by the final coating of the diluted wood sealer, which may cause problems during any retreatment effort. The need for a final coating should be established by analysis of treated samples.

Man-hours for initial application:

Cleaning	500
First application dilute linseed oil	150
Second application dilute linseed oil	150
Third application 100% linseed oil	150
Final application wood sealer	<u>100</u>
Total man-hours	1,050

Maintenance schedule: The application of the above preservation treatment on the Confederate ram Neuse, in combination with a covering structure, appears to be an adequate method of wood stabilization. The application of a linseed oil preservation treatment was made to check for problem areas and to keep the ship clean of accumulations of foreign matter. It appears that major reapplications of this preservative should be on a ten-year schedule.

Informational source:

Leslie S. Bright
N.C. Dept. of Cultural Resources
Preservation Laboratory
P.O. Box 58/Doire Beach, NC 28449
Tel. 919/458-5203

(iv) Option IV - Peg/PQ-57

Chemical composition:

Polyethylene Glycol (Peg 4000)
PQ-57 copper-8-quinoliontate

Method of application: The Cairo timbers, even after placement under the covering structure, will undergo additional physical damage caused by shrinkage and checking as the wood dries. The initial applications of these chemicals should therefore be made before the cover is completed. Steps are as follows:

- Clean as in earlier options. The hot water spray will facilitate absorption of the PEG and PQ-57 mixture.
- Spray daily until saturated for one week with 10% PEG, 5% PQ-57, and warm water. Spraying can be continued for additional days depending on the absorption rates of the solution in the wood.
- Repeat with same process in five to six months.

Anticipated adverse effects: The PQ-57 may impart a greenish cast to the wood as well as darken the timbers.

The PQ-57 may cause foaming problems during the application. If this occurs, Dr. Fritz Nagel of the Chapman Chemical Co. should be able to help.

Man-hours for initial application:

Cleaning and hot water spray	500
Seven applications of dilute PEG-PQ57	300
Reapplication in 6 months	<u>400</u>
Total man-hours	1,200

Maintenance schedule: Annual application has been recommended; however regular visual surveying of the condition of the wood will determine if this is necessary.

Informational source:

Terry L. Amburgey
 Plant Pathologist
 US Dept. of Agriculture
 Southern Forest Exp. Station
 P.O. Box 2008, GMF
 Gulf Port, MS 39503

(2) Metal Preservation

(a) In-place Metal Fabric Preservation Options

Rusted iron is normally easily stabilized by removing the corrosion covering and treating the underlying metal. This is especially true with large objects without any significant surface detail or highlights. Restoration of the twisted and bent iron components may be rather difficult and will require forge heating to straighten to their original configuration; during this process the existing corrosion layer will be removed so that sealing and painting will become an important preservation item.

(i) Option I: No Treatment

This option is unacceptable. Option I will do nothing to stabilize the existing metal fabric of the U.S.S. Cairo. Unlike the rot and decay now continuing in the wood portions of the vessel, the exfoliation of Cairo metal components will not cease when the vessel is placed under cover. This deterioration is chemical in nature and chemical neutralization is warranted to prevent further corrosion of the metal fabric.

(ii) Option II - Zinc Paint/Black Enamel
Paint

Constituents:

Manganese-Phospholene #7 (primer coat)
Zinc silicate coating (protective coat)
Black enamel (final protective coat)

Method of application: The existing fabric of the Cairo contains approximately 10,000 metal spikes, pins, nails, hooks, and rods in varying degrees of oxidation, which are partially exposed and still serve to connect the Cairo timbers. The majority of these spikes and pins contain heavy surface rust and scale in their exposed sections. There are three steps:

- Mechanical cleaning is necessary to remove the worst of the rust and scale from the exposed portions of the fasteners. The majority of fasteners still connect the timbers and cannot be removed from the wood fabric. Cleaning can be accomplished with electric drills with wire cap brushes or by hand brushing.
- Manganese-phospholene #7 primer can then be brushed on all cleaned exposed metal to consolidate the remaining rust. This chemical requires no after washing or neutralization; it does not harm wood and will act as a paint primer upon drying. Excess chemical and loose rust should be wiped away.
- An inorganic zinc silicate compound should then be applied to the metal as a protective coating for all exposed portions of the iron nails and spikes. Final coating with zinc silicate paint leaves an appearance very similar to galvanizing. If this appearance is deemed unacceptable, an additional coating of black enamel can be added for aesthetic reasons.

Anticipated adverse effects: Care must be taken in the application of the manganese-phospholene. If spilled on the wood, the chemical would probably lighten its color. The ultimate final appearance of the nails and spikes, whether similar to galvanizing or painted black, will alter the appearance of the vessel from its present state. Black

paint treatment, however, will match the larger metal artifact treatment since these objects will also be given a final coating of black paint.

Man-hours for initial application:

Mechanical cleaning	400
Application of primer	150
Wipe clean	50
Protective coat	200
Final coat	<u>200</u>
Total man-hours	1,000

Estimated maintenance schedule: In-place iron on the Confederate ram Neuse was treated similarly ten years ago and shows no sign of further chemical decay. Maintenance should be scheduled periodically as spot conditions warrant.

Informational source:

Mr. Leslie S. Bright
N.C. Dept. of Cultural Resources
Div. of Archives and History
Archaeology Branch
P.O. Box 58
Kure Beach, NC 28449

(iii) Option III - Coal Tar Epoxy

Constituents: This two-coat process involves a primer coat of manganese-phospholene #7 and then an epoxy coal tar protective coating.

Method of application:

- Mechanical cleaning
- Application of manganese-phospholene #7 primer
- Wiping clean
- Application of coal tar epoxy coating

Anticipated adverse effects: The epoxy coal tar is designed for installations where highly corrosive chemicals are present. It is a very thick coating and quite irreversible. Epoxy coal tars are hard to paint and have a relatively short pot-life after mixing. Their curing process is a chemical reaction rather than air drying.

Man-hours for initial application:

Mechanical cleaning	400
Rust removal	150
Protective coating	<u>400</u>
Total man-hours	950

Estimated maintenance schedule: It is anticipated that this treatment will last a minimum of ten years, with or without a cover.

Informational source:

Lee Gjouic
Forest Products Lab
Madison, WI
608-257-2211

Leslie Bright
N.C. Dept. of Cultural Resources
Div. of Archives and History
Archaeology Branch
P.O. Box 58
Kure Beach, NC 28449

(b) Unattached Metal Fabric Preservation

Options

(i) Option I - No Treatment

This alternative is unacceptable whether the larger metal Cairo components are to be remounted onboard or displayed separately. Metal stabilization is a relatively simple matter and should not be neglected with these items. Although most of these components (boilers, engines, armor plate, and paddle wheel elements) are in good condition, some pieces (i.e. railroad iron) show heavy exfoliation. These components should be treated so that all pieces are stabilized for present or future mounting aboard the Cairo.

(ii) Option II - Sand Blasting Followed by
Primer and Black Enamel Paint

Process: Due to the large size and non-fragile nature of these items, mechanical abrasion is a feasible alternative to remove rust. Glass bead peening would be the preferred cleaning method over sand or steel shot blasting. Some of these components, such as the engines, paddle wheel, and other pieces, were sandblasted at Pascagoula during 1965. They were then coated with a thick petroleum-based

substance labelled "cosmoline". The remains of the cosmoline can still be seen and should be scraped off before any new blasting. Other areas of thick scale or rust should also be scraped before mechanical cleaning.

Method of application:

- Precleaning--the worst scale, rust, and old coatings should be scraped from the surface before blasting.

- Sand Blasting--to achieve adequate force to peen the subject piece, a spray system capable of 10 CFM, with a constant pressure of 100 to 150 psi should be used. However, the lowest operable pressures are desirable.

- Cleaning--after sand blasting, the component should be cleaned and dried.

- Protective Coating--the metal fabric will need one primer and two final protective coats to prevent further oxidation. For the coating to be effective, however, the surface to be coated must be clean and dry and the coating itself must be continuous, without scratches or nicks. One coat of a red lead primer followed by two final black enamel coats should provide sufficient protection from oxidation.

Man-hours for initial application:

Precleaning	1,500
Peening with glass beads	2,000
Cleaning	500
Protective coating	<u>3,000</u>
Total man-hours	7,000

The above figures only deal with the preservation coatings. These calculations do not include any restoration measures such as straightening, bolting, rewelding, or other techniques designed to reassemble the metal fabric.

Estimated maintenance schedule: Minimum 10 years life with cover structure.

Informational source:

Accumulated from several sources including:

Dan Riss
Metals Conservator
Harpers Ferry Center
National Park Service
Harpers Ferry, WV 25425

C. Cairo Restoration Program Alternatives

The following alternatives combine in various ways the philosophies and the various technical treatment options described earlier in this document. Alternative E is the program selected in 1979 on preliminary presentation of this information and thus is most fully developed.

1. Alternative A--Minimum Preservation

a. Discussion

This alternative only treats existing wood and in-place metal components currently in the dry berth and is not recommended. Alternative A is not consistent with National Park Service management policies and requirements. Furthermore, the legislative and public expectations concerning the Cairo involve a more substantial presentation of the gunboat than this alternative would attempt.

b. Estimated cost

Preservation treatment	\$27,000
Temporary structural system to remain "as is"	0
No preservation of unattached metal fabric	0
No onboard interpretation	0
Subtotal	<u>\$27,000</u>
20% Contingency	<u>5,400</u>
Total	\$32,400

2. Alternative B - Minimal Preservation and Restoration

a. Discussion

This is probably the least desirable alternative that is minimally consistent with NPS management policies. This minimal restoration will not fulfill Vicksburg NMP management objectives or public expectations concerning the Cairo. Therefore, alternative B is not recommended.

Alternative B proposes to shim the Cairo hull to its proper shape. Shimming will provide space between the existing steel structure and the wooden hull. The space could then be blocked to keep

the hull sides separated from the steel support frames. After shimming, the existing plywood sheathing could be removed. The exposed hull planking could then be properly treated with wood preservatives. One additional benefit of shimming the hull sides will be the access allowed to the steel frames for painting the entire surface area of the steel.

b. Necessary Tasks to Complete Alternative B

- Jack wood fabric of vessel currently in berth back into its original shape
- Remove in-place nails, spikes, etc., that are not required
- Remove all temporary internal support systems
- Provide new support at bow and catamarans as necessary to replace existing internal supports
- Remove portions of vessel fabric that are not attached (i.e. loose gun deck beams, strakes, etc.)
- Remove all plywood sheathing that is currently part of the temporary system
- Block vessel back into its original shape so that no fabric rests on steel supports
- Clean all in-place metal fabric of loose scale and rust
- Clean fabric of construction debris as well as any loose organic material, dirt, soft rot, scaling, etc.
- Apply preservation treatment to all wood fabric stored onsite and in berth
- Provide wood supports for all wood fabric not currently in berth; display around site
- Apply chemical treatments to all in-place metal fabric throughout wood sections
- Paint in-place metal fabric
- Scrape, blast, clean, and paint all metal fabric not physically associated with major wooden portions
- Provide wooden supports for all metal fabric for display around site

Note: Alternative B proposes only minimal interpretation outside the museum.

c. Estimated Cost

Preserve all existing wood fabric and in-place metal fabric	\$ 30,000
Shim fabric back into its proper shape	50,000
Preserve metal components and display near ship	50,000
Minimum shelter	450,000
No onboard interpretation	0
No reconstruction	0
Subtotal	<u>\$580,000</u>
20% contingency	<u>116,000</u>
Total	<u>\$696,000</u>

3. Alternative C - Partial Restoration I

a. Discussion

The biggest single improvement of alternative C over B is the replacement of the steel support system with a laminated wood beam system. A laminated wood support system would provide an immeasurable aesthetic benefit by visually simplifying the support structure. The major defects in utilizing the existing steel system are twofold:

the steel structure should not be allowed to touch the historic wooden fabric, as it presently does; and

the maintenance involved in painting the steel would be expensive.

It should be noted that the 15-year-old steel supports now used for internal bracing are badly deteriorated and are virtually useless.

A glue-laminated replacement system should present a clean and simple structural framework, providing a good contrast between old and new fabric, and should be relatively maintenance free. The wooden members would have considerably less deterioration and future

maintenance than the steel system presently used. The initial cost of a glue-laminated system is anticipated to be quite similar to other new systems of different materials.

The major disadvantage of alternative C is that it does not consider mounting fabric not already in the berth. The other wood fabric sections currently stored elsewhere on the site are not considered in this alternative. These unmounted sections could be displayed on wooden supports elsewhere on the site. This is, however, a less than optimum solution. All the ship components should surely be remounted in their proper positions.

Also, no provisions would be made to allow the visitor on board the Cairo; all viewing would be from the berth's perimeter. Alternative C is not recommended.

b. Necessary Steps To Complete Alternative C

- Jack wood fabric of vessel back into its original shape
- Remove in-place nails, spikes, and rods that are not needed
- Remove earlier internal support systems
- Remove existing external steel and plywood support system
- Provide new support system of laminated wood beams to replace existing internal and external support systems
- Clean, treat, remove, and store all existing wood members currently laying loose in the berth (i.e., hull side sections, strakes, etc.)
- Clean loose scale and rust from all in-place metal fabric
- Clean the existing sections of wood fabric of all construction debris, organic material, dirt, loose scale, etc.
- Apply preservation treatment to all wood fabric stored onsite and in the berth.
- Provide wooden stands or supports for all wood fabric not currently attached and display onsite
- Apply chemical preservation treatments to all in-place metal fabric on all wooden sections
- Provide protective coatings to all in-place metal fabric as discussed in this report
- Provide scraping, blasting, and cleaning for all pieces of metal fabric not currently attached to major wooden sections of the fabric
- Provide protective coatings for all above pieces
- Provide wooden display supports for all preserved metal fabric and display on-site

Note: The removal of the existing system must be accomplished in such a manner as to facilitate the new glue-laminated system. This new system is intended only to provide structural support for the wooden fabric now in the berth; it does not provide for mounting other wood or metal components.

c. Estimated Cost

Preservation treatment of all existing wood fabric and in-place metal fabric	\$ 30,000
Provide new structural system for wood fabric in berth only, plus removal of existing systems	275,000
Preservation of metal components and provision for display near ship	50,000
Minimum shelter	450,000
Minimum interpretation	75,000
No reconstruction	0
Subtotal	<u>\$ 880,000</u>
20% Contingency	<u>176,000</u>
Total	\$1,056,000

4. Alternative D - Partial Restoration II

a. Discussion

The major advantage of alternative D over alternative C is the additional mounting of all wood fabric not currently in the concrete berth. The front casemate, portions of the gun deck, paddle wheel blocks, and some gun deck beams are all included in the additional fabric to be mounted under this option. This alternative does not, however, propose to mount all the metal fabric currently available onsite. The metal fabric can be displayed elsewhere, but this would also be less than an optimum solution. The bulk of the propulsion system could be mounted with minimal additional expense under this alternative. This would include the paddle wheel, engines and mounts, boilers, and pitman arms. Viewing ledges for visitors which would allow a closer view of these propulsion mechanisms could be added for an additional expense to alternative D.

This alternative falls short of fulfilling the legislative and public expectations as well as management objectives/requirements for this project and it is not recommended.

b. Necessary Steps to Complete Alternative D

In addition to the steps outlined under alternative C, the following steps must be carried out to complete alternative D:

- Provide an additional laminated wood beam structural system, integrated with that built in alternative C, to support the additional noncontinuous wood fabric stored around the site
- Provide for the restoration of some of the metal fabric, primarily the components of the propulsion system, including:

all pieces of the paddle wheel shall be straightened and bolted back together

pillow blocks shall be restored and mounted for acceptance of the paddle wheel shaft

the engine mounts shall be restored and mounted to accept engines

engines shall be remounted and connected to pitman arms

pitman arms shall be reassembled around reconstructed wood cores and remounted to wheel cranks and engine piston rods

the five boilers and their associated hardware should be repaired and remounted

- Provide the necessary structural support for all restored metal fabric to be remounted onboard the vessel. These supports should become an integral part of the other wood support systems previously described
- Provide concrete viewing ledges to the fabric edge (at about the location where the knuckle once was) to allow the visitor a closer view of the mounted mechanisms

Note: Preservation treatment is the same as that included under alternative C for both wood and metal historic fabric located onsite.

c. Estimated Costs

Preservation treatment of all existing wood fabric and in-place metal fabric	\$ 30,000
Provide new structural support system for all wooden fabric and some metal components	300,000
Restore metal components as necessary for mounting onboard; also provide for display for remaining fabric near ship	250,000
Minimum shelter	450,000
Minimal interpretation	150,000
Reconstruct individual members as necessary	20,000
Subtotal	<u>\$1,200,000</u>
20% Contingency	<u>240,000</u>
Total	\$1,440,000

5. Alternative E - Partial Restoration III (Selected Alternative)

a. Discussion

Alternative E presents a good coalition of preservation and restoration and is the recommended program treatment for the Cairo. This alternative preserves and stabilizes all the Cairo historic fabric, places all wood and metal components in their correct location on the gunboat, and provides a substantially restored gunboat without any conjectural or expensive reconstruction.

All the existing boat fabric, both wooden and metal, would be preserved in a manner outlined in the preceding alternatives. Every identifiable part and component would be mounted on a new Cairo glue-laminated wood support structure.

The proposed new structural support system is designed to both support all the Cairo historic fabric remains in their proper places and visually link the various surviving components together by ghosting the outline and form of the missing gunboat sections (figure 12). Ghosting will unify and define the existing disjunct image that the Cairo fabric now conveys. Totally missing parts of the boat such as the hurricane deck, after casemates, stacks, ship's boats, and wheelhouse will be outlined in framework form by the ghosting of alternative E.

Clean detailing of the new structural system connections and locating the new support members in positions approximate to the original ironclad's construction will enhance the display without overwhelming the historic fabric (figure 13).

The use of laminated wood beams for the support system will provide a distinct visual contrast between old and new. The visitor will have very little doubt as to the distinction between new National Park Service work and the Civil War construction.

Alternative E also proposes a visitor access ramp or "bridge" across the Cairo at approximately midships (figures 14 & 15). This midships bridge, spanning the berth, will allow views of the propulsion system, armament, and interior spaces from an "onboard" position.

b. Necessary Steps to Complete Alternative E

- Jack wooden fabric of vessel back into its original shape
- Remove in-place nails, spikes, and rods that are not required
- Remove previously installed internal support systems
- Remove existing external steel and plywood support system
- Provide new support system of laminated wood beams to replace existing internal and external systems. The laminated wood support system should support the mounting of all existing metal and wooden fabric now on site. Its visual goal is a continuous and clean quality. An additional benefit of this system is its ghosting, which simplifies envisioning the vessel's original form when only partial fabric exists
- All unattached wooden fabric should be cleaned and remounted if its original location can be determined
- Clean loose scale and rust from all in-place metal fabric
- Clean all construction debris, loose organic material, dirt, scale, soft rot, etc., from the existing fabric
- Apply preservation treatment to all portions of the wooden fabric
- When the support system is completed, mount all portions of the wood fabric that are currently stored onsite
- Apply chemical preservation treatment to all in-place metal fabric on all major portions of the wooden fabric
- Provide protective coatings to all in-place metal fabric
- Restore the identifiable metal fabric. The following list includes most larger objects needing work:
 - All pieces of the paddle wheel require straightening prior to reassembly

Pillow blocks shall be restored and mounted for acceptance of the paddle wheel shaft

Engine mounts shall be restored, reassembled, and remounted to accept engines

Engines shall be restored, remounted, and connected to the pitman arms

Pitman arms shall be reassembled around reconstructed wood cores and remounted to wheel cranks and engine piston rods

Boilers and associated hardware (breeching, steam drum, mud drum, etc.,) shall be repaired and remounted

All existing armor plate shall be remounted

Iron plating for the pilothouse shall be preserved and remounted in its position at the hurricane deck level

Railroad iron shall be remounted and straightened as necessary

All remaining iron artifacts for which a positive identification is possible will also be remounted such as davits, roller chocks, rods and cams, rudder hardware, etc.)

- Scrape, blast, and clean all iron fabric as deemed necessary
- Provide protective coatings for all metal fabric
- Provide for display and/or storage for any unidentified artifacts not remounted

c. Estimated Costs

Preservation treatment of all existing wood fabric and in-place metal fabric	\$ 63,000
Provide new structural support system for all wooden fabric and all metal components, plus removal of existing systems	500,000
Provide for restoration and preservation of all metal components and mount all pieces "onboard"	750,000
*Space frame shelter	700,000
Interpretation and visitor access over fabric by bridge	60,000
Reconstruction of individual members as necessary	200,000
Subtotal	<u>\$2,273,000</u>
7% contingency**	<u>177,000</u>
Total	\$2,450,000

*Work on the space frame shelter was completed on 11/1/80 at a cost of \$689,924.00. This element dropped from package estimating detail of 12/1/80 because complete.

**The contingency amount has been adjusted to reflect budget updates since this alternative was selected.

UNITED STATES DEPARTMENT OF THE INTERIOR
NATIONAL PARK SERVICE

PACKAGE ESTIMATING DETAIL

REGION Southeast	PARK Vicksburg N.M.P.
PACKAGE NUMBER 101	PACKAGE TITLE Cairo Development

(If more space is needed, use plain paper and attach)

ITEM	QUANTITY	COST
1. Preservation treatment of all existing wood fabric and in-place metal fabric.		63,000
2. Provide new structural support system for all wooden fabric and all metal components plus removal of existing structural systems.		500,000
3. Provide for restoration and preservation of all metal components and mount all pieces "on board".		750,000
4. Interpretation and visitor access over fabric by bridge.		60,000
5. Reconstruction of individual members as necessary.		200,000
Sub Total		1,573,000
6. Contingency.		177,000
Total		1,750,000

SUMMARY OF CONSTRUCTION ESTIMATES		CLASS OF ESTIMATE		
		<input type="checkbox"/> Working Drawings	<input type="checkbox"/> Preliminary Plans	<input checked="" type="checkbox"/> Similar Facilities
Proj. Type		Totals from Above B & U R & T		
52	Museum Exhibits			XXXXX
55	Wayside Exhibits			XXXXX
62	Audio-Visual			XXXXX
89	Ruins Stabilization			XXXXX
91	Construction			
92	Utility Contracts			XXXXX
ESTIMATES APPROVED (Signature) <i>A. James McLeath</i>		(title)	(date) 12/1/80	

6. Alternative F - Half Preservation/Half Reconstruction

a. Discussion

This alternative has been repeatedly considered during Cairo development planning. In previous reports, this concept has been discussed in terms of a longitudinal division: the port side would be preserved and the starboard side would be preserved and reconstructed where fabric is now missing. This is a logical approach since the starboard side is subjected to more weathering from afternoon sun and prevailing winds. It would also be possible for the visitor to view the total ship from the viewing ramps and museum roof.

This alternative does offer the visitor a comparison of existing fabric in situ with a reconstruction technically accurate in terms of methods and fairly accurate in terms of materials available today.

The visitor could have access only to the gun deck level. Entrance at the hurricane deck level is structurally complicated and expensive, offering a minimal return in visitor experience. He or she could have a close view of the propulsion system, two typical gun mountings, a typical officer's stateroom, and, most important, could get a feeling of the cramped, dark space available to the fighting men on these vessels. This is similar to Option III of the 1976 Barry Howard report.

However, current thinking is that partial reconstruction would be less detrimental to existing fabric and provide the visitor with the same advantages noted above if the work was done at the midship section of the gunboat (approximately from frames 60 to 85, or approximately 40 feet in length). A midships section reconstruction would be very similar to a portion of Option II in the Barry Howard report. Either of these programs would be quite expensive and neither is recommended.

b. Necessary Steps to Complete Alternative F

- Remove existing gun deck beams and existing decking and replace with new material to provide a structural base for visitor entry

- Remove stanchions on port catamaran waterway and replace with new material to give support to the catamaran gun deck
- Replace missing sections of the gun deck shelf up to frame 90 with new material to offer a continuous gun deck from the fantail to frame 90. Other areas will be preserved and visitor access will not be allowed
- Reconstruct the gun deck with new beams and decking
- Retain hull sides below the knuckle to minimize the destruction of existing fabric. This will also minimize interface of old and new, eliminating many joining problems
- Reconstruct the side and rear casemates
- Reconstruct the hurricane deck on the starboard side
- Reproduce the interior features, such as officers' cabins and armament rigging finishes, as accurately as possible
- Reconstruct the starboard portion of the wheelhouse

c. Estimated Costs

Preservation treatment of all existing wood fabric and in-place metal fabric	\$ 30,000
Provide new structural support system for all existing wood fabric plus removal of existing systems	450,000
Provide for restoration and preservation of all metal components and mount all pieces	500,000
Space frame shelter	650,000
Full "on board" interpretation in the reconstructed areas of the gun deck level	150,000
Reconstruct the starboard portion of the vessel from (and including) the gun deck up, from the fantail forward to frame	700,000
Subtotal	<u>\$2,480,000</u>
20% Contingency	<u>496,000</u>
Total	\$2,976,000

7. Alternative G - Theatrical Reconstruction, and Alternative H - Historical Reconstruction

a. Discussion

In a theatrical reconstruction, the end product will look like the historic one, but contemporary methods and materials may be used. A historic reconstruction requires use of historic methods and materials or material types. In both of these alternatives, all missing portions of the gunboat fabric would be reconstructed and all existing fabric deemed useable would be incorporated onboard the Cairo. Structural considerations, however, would probably eliminate certain

portions of the existing fabric. Those portions of unsound Cairo fabric would have to be sacrificed in order to support the weight of reconstructed areas as well as to be structurally sufficient to support visitors onboard.

A distinct disadvantage of both alternatives G and H is the irreversible damage to historic fabric; between the structural support system and the new fabric involved in these two proposals, the existing fabric is either obscured or eliminated by the demands of a new structure superimposed on the boat remains.

The major advantage of both alternatives G and H would be to provide the added interest of onboard interpretation of Cairo artifacts and the clear presentation of the ship's spatial relationships to the visitor. The above benefits do not appear to be significant enough to justify the increased costs, therefore alternatives G and H are not recommended.

b. Estimated Costs - Alternative G

Preservation treatment of all wood fabric and in-place metal fabric	\$ 30,000
Provide new structural support system for wood fabric and remove existing systems	450,000
Restore and preserve all metal components and mount all pieces onboard	500,000
Space frame shelter	650,000
Full onboard interpretation in the reconstructed gundeck level	200,000
Reconstruct the missing portions of the vessel from the gun deck up, using techniques and materials not necessarily historically accurate, but that appear similar to the original construction	1,000,000
Subtotal	<u>\$2,830,000</u>
20% Contingency	566,000
Total	\$3,396,000

c. Estimated Costs - Alternative H

Same as alternative G except all reconstructed areas would be accomplished using materials and techniques closely following

those historically appropriate. A supplier is not currently available that can produce the historically correct white oak heavy timbers, therefore no correct pricing is really available and pine is substituted for cost analysis.

Subtotal	\$3,200,000
20% Contingency	<u>640,000</u>
Total	\$3,840,000

8. Alternative I - Restoration Plus Full Reconstruction

a. Discussion

This final alternative is probably the best from the interpretation, preservation, and visitation viewpoints. It is the most complex and most expensive alternative.

The alternative I proposal includes completion of a full restoration as discussed under part E of this section plus a full or partial reconstruction of the Cairo to be placed in a similar berth adjacent to the original fabric.

Essentially, this alternative includes the monetary obligation of alternative E and the price of a complete reconstruction from scratch (including the price of another berth and related site work). Alternative I is beyond the reality of the present budget, but it is the logical culmination of the previous alternatives.

A slight variation of this proposal would be to eliminate the bulk of the existing portions of wooden fabric. Some fabric could be reused, but the gun boat would basically be a total reconstruction.

The above variation is one of the least desirable alternatives from a preservation standpoint. However, it does offer other advantages: the covering structure could be eliminated and the visitor could wander freely on the ship (a detailed structural analysis would be necessary for this alternative).

Alternative I is not a feasible option considering present budget and management policies. The previous alternatives are all much more consistent with present policies than the complete replacement of the existing historic fabric with a modern reconstruction. Given an unlimited budget the "side-by-side" alternative, preserving what has survived and building a replica next to the historic remains, probably best incorporates all the divergent demands involved in displaying the Cairo to the public.

b. Estimated Costs

Cost of alternative E		\$2,450,000
No additional shelter (Maintenance would be less with a shelter and should be compared)		0
Reconstruction of the total vessel using materials and techniques closely following those used historically		<u>1,500,000</u>
	Subtotal	<u>\$3,950,000</u>
	20% Contingency	<u>790,000</u>
	Total	\$4,740,000

9. Notes

a. Alternatives G, H, I

All the reconstruction alternatives would involve a significant amount of construction and detailing conjecture as all records and evidence of those now-missing gunboat sections have either been destroyed or never existed.

b. General Note

All the above alternative costs do not include costs involved with the Cairo shop and tools, crane, site work, museum work, or supervision. Funds for the above work have already been allocated from the original \$4,973,000 Cairo appropriation, leaving an unused balance of \$2,650,000 available for the Cairo program treatment.

**DRAWINGS FOR
CAIRO RESTORATION**

U.S.S. Cairo Development Vicksburg National Military Park

HISTORIC STRUCTURE REPORT



VICINITY MAP

SITE

LOCATION MAP

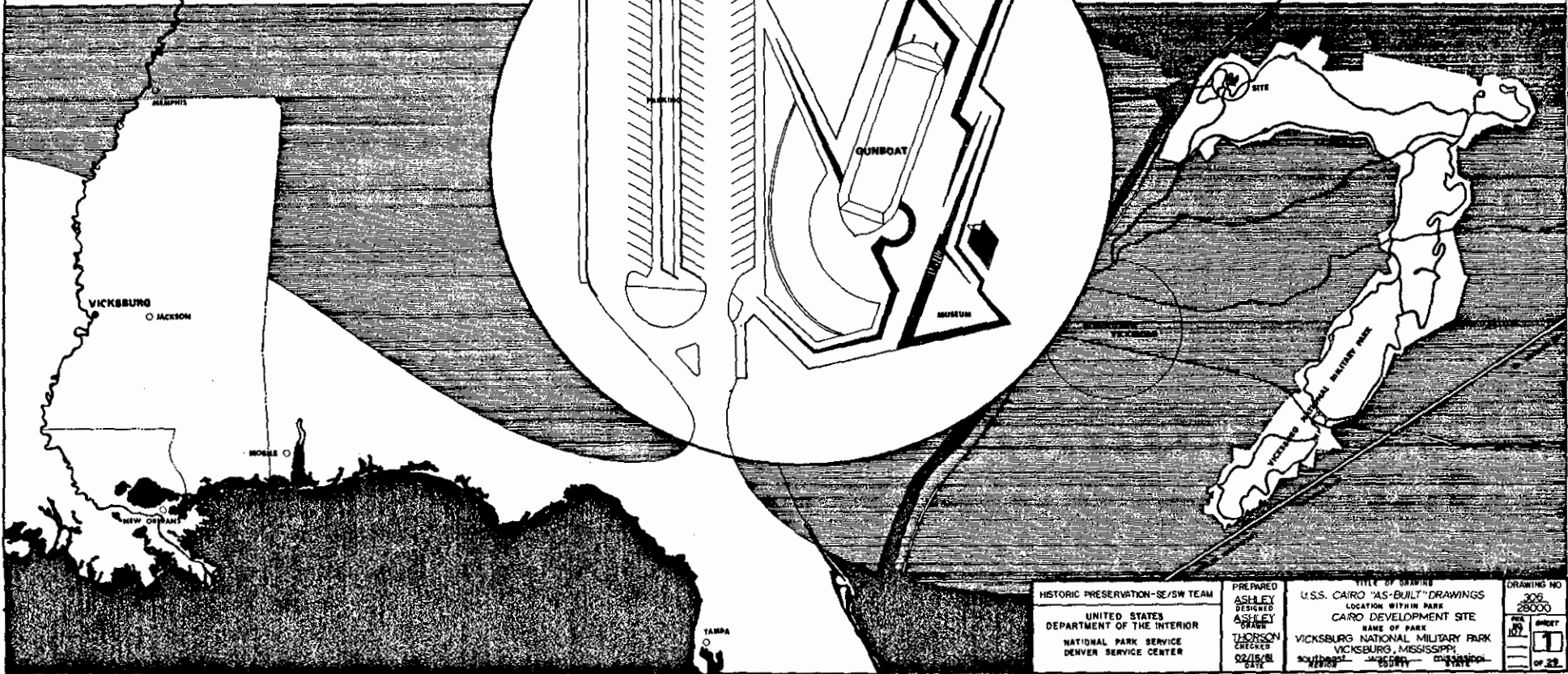
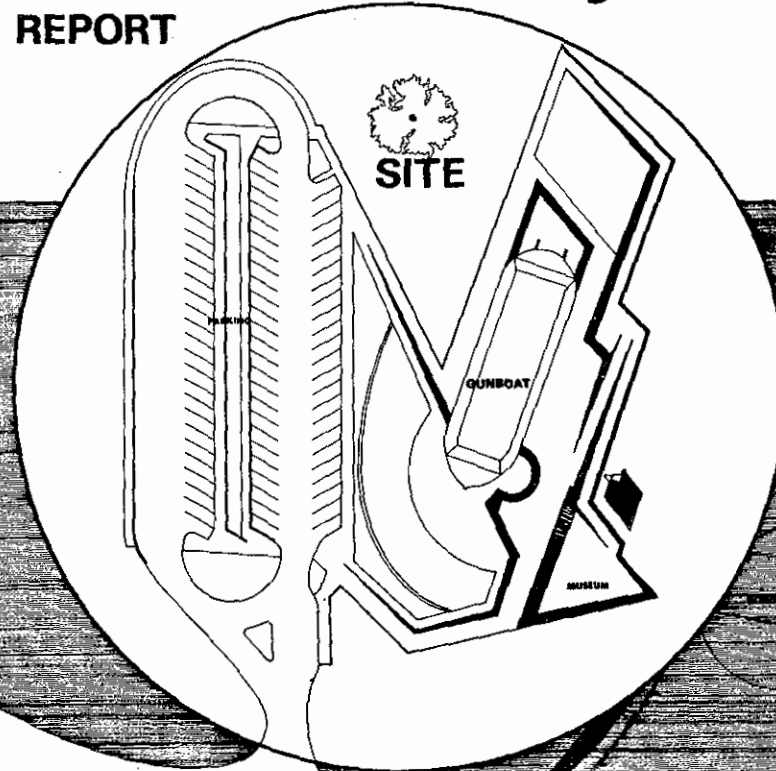

HISTORIC PRESERVATION-SE/SW TEAM
UNITED STATES
DEPARTMENT OF THE INTERIOR
NATIONAL PARK SERVICE
DENVER SERVICE CENTER

PREPARED
ASHLEY
DESIGNED
ASHLEY
CHECKED
THORSON
DATE

TITLE OF DRAWING
U.S.S. CAIRO "AS-BUILT" DRAWINGS
LOCATION WITHIN PARK
CAIRO DEVELOPMENT SITE
NAME OF PARK
VICKSBURG NATIONAL MILITARY PARK
VICKSBURG, MISSISSIPPI
SCALE 1" = 250 FT

DRAWING NO.
306
28000
SHEET
1
OF 22

ON MICROFILM

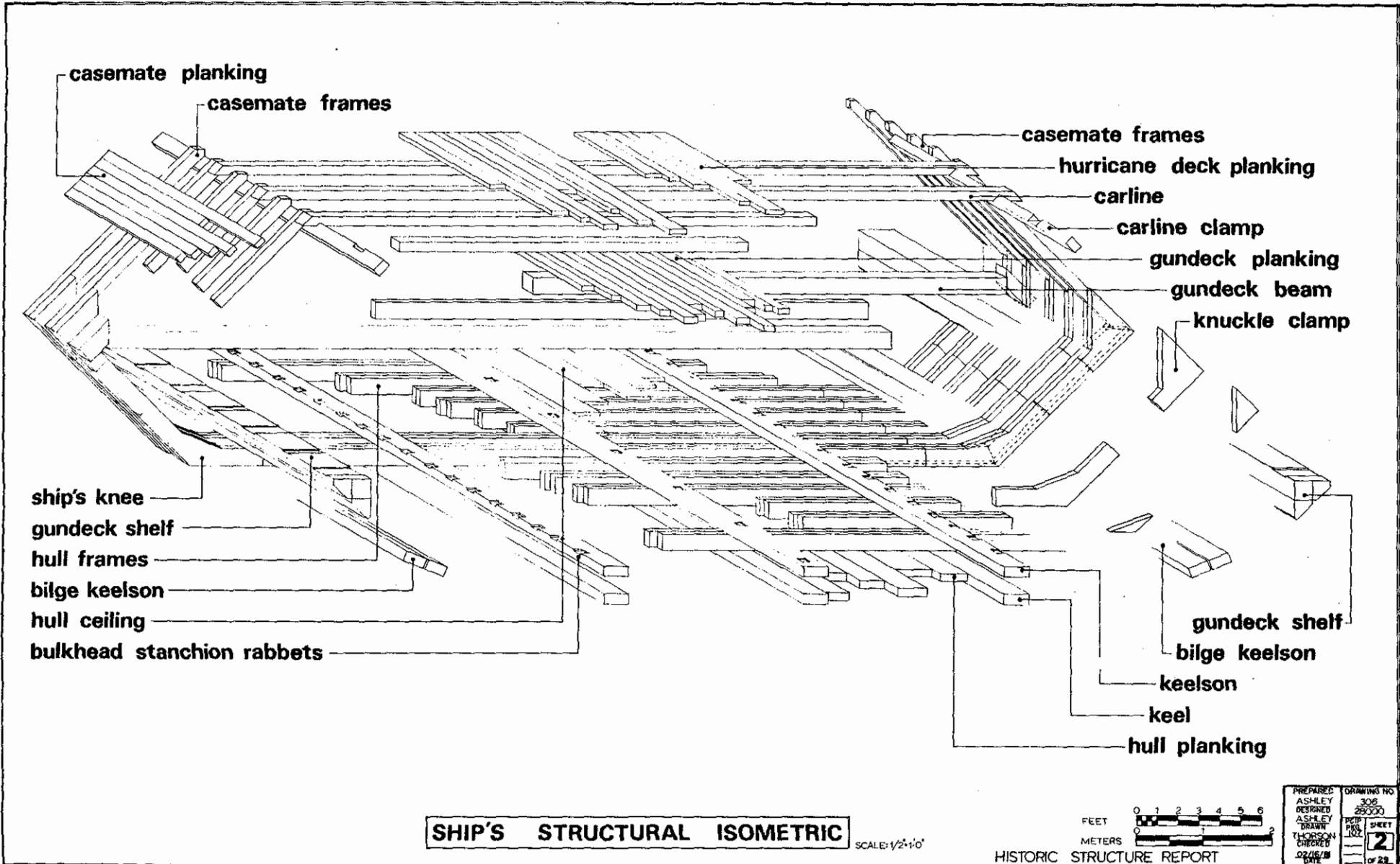

SHIP'S STRUCTURAL ISOMETRIC

SCALE: 1/2"=1'-0"

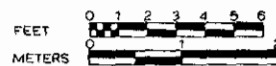

HISTORIC STRUCTURE REPORT

PREPARED	ASHLEY	DRAWING NO.	306
DESIGNED	ASHLEY		28300
DRAWN	ASHLEY		
CHECKED	THORSON		
DATE	02/16/58		
		PAGE	102
		SHEET	2
		OF 22	

ON MICROFILM

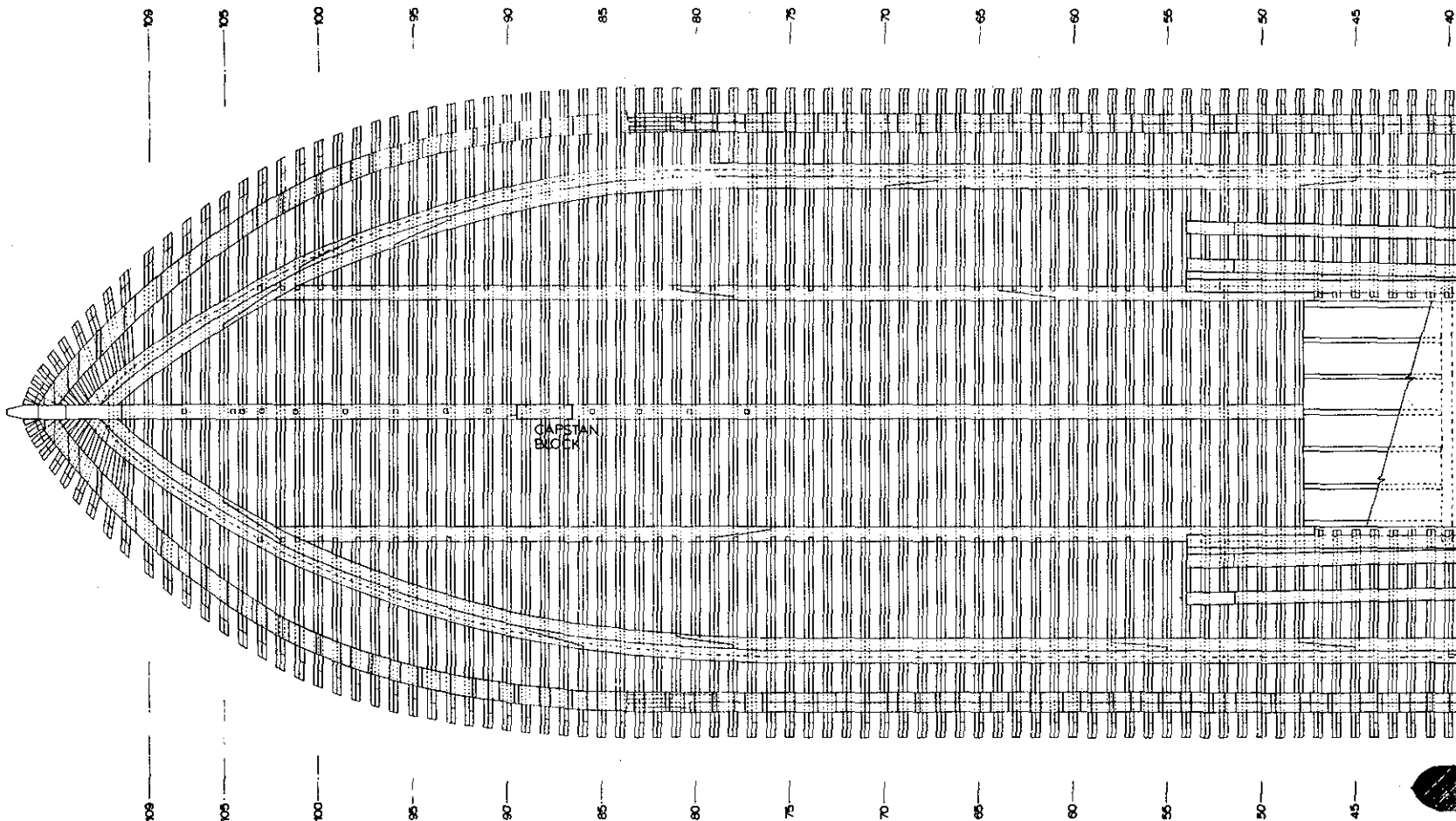

HULL FRAMING - FORWARD

SCALE: 1/4"=1'-0"

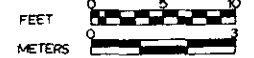

HISTORIC STRUCTURE REPORT



key

PREPARED DA/TM DESIGNED ASHLEY DRAWN THORSON CHECKED DRA/CI	DRAWING NO 306 28000	SHEET 3 OF 28
--	----------------------------	---------------------

GPC 1314-878-715

ON MICROFILM

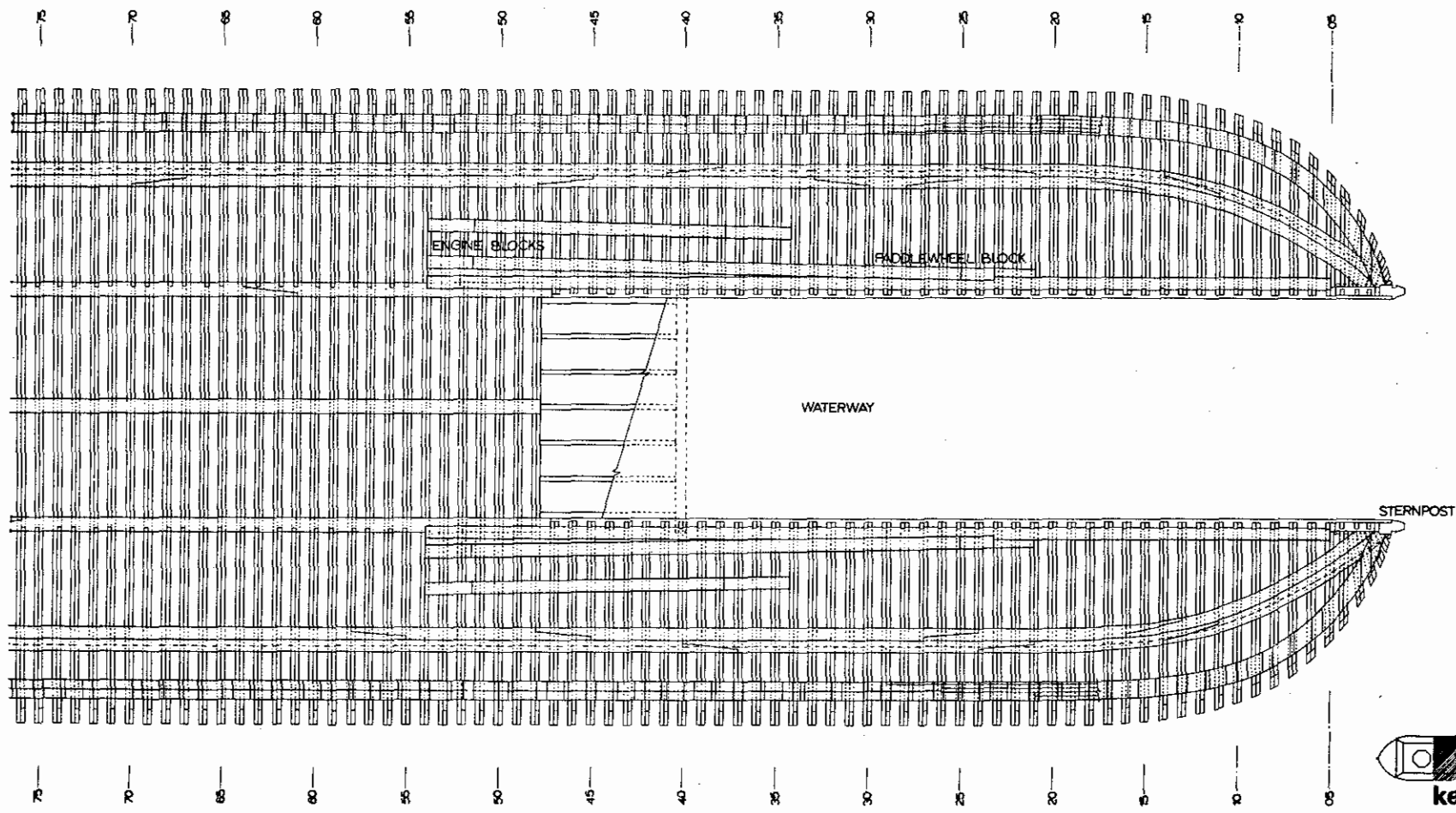

HULL FRAMING - AFT

SCALE 1/4"=1'-0"

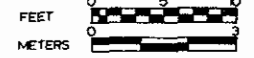

HISTORIC STRUCTURE REPORT



PREPARED	DA/TM	DRAWING NO.	305
DESIGNED	ASHLEY	NO.	25000
DRAWN	THORSON	SHEET	4
CHECKED	DATE	OF 23	

ON MICROFILM

OPC-174-678-774

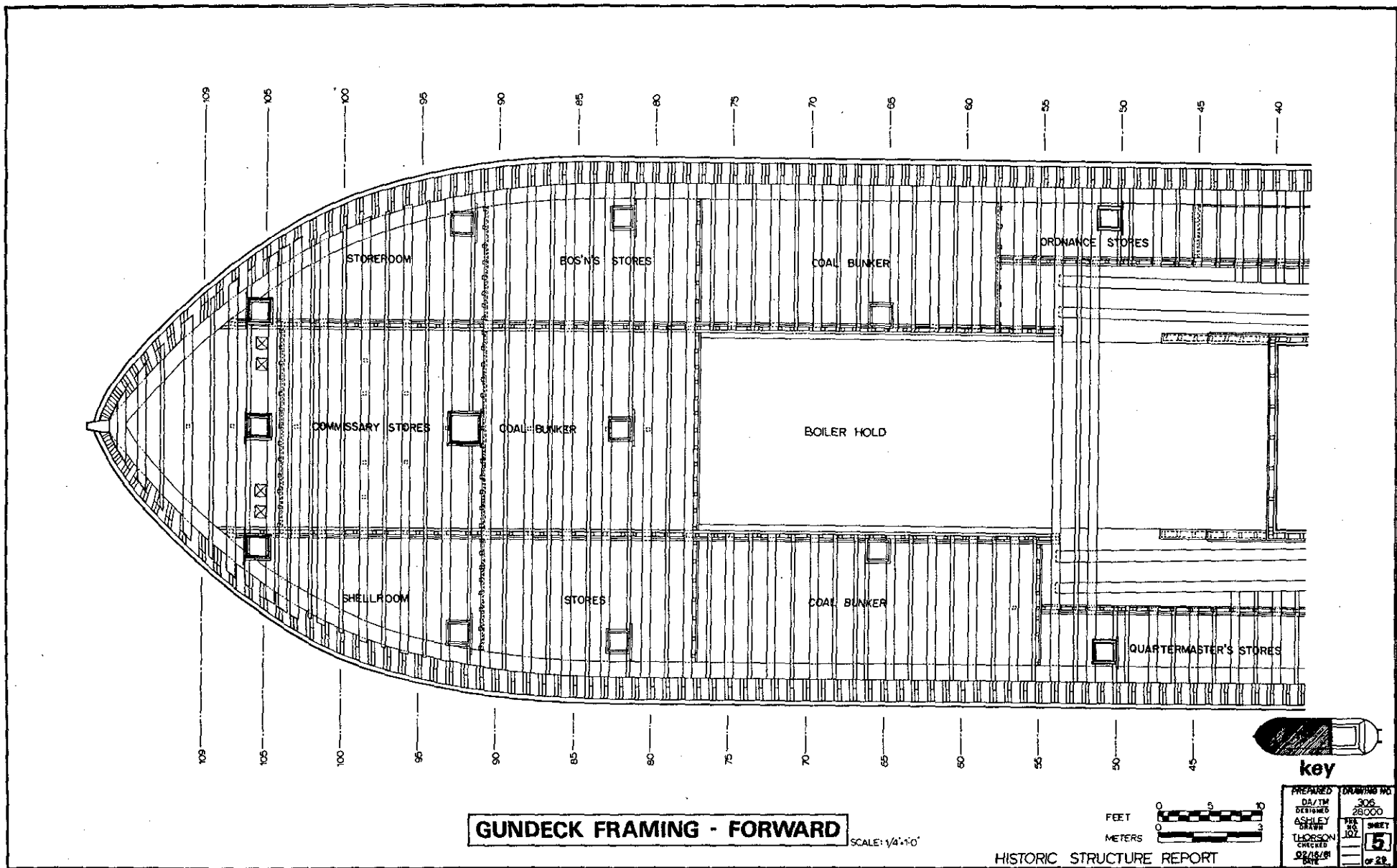

GUNDECK FRAMING - FORWARD

SCALE: 1/4"=1'-0"

FEET



METERS



HISTORIC STRUCTURE REPORT

key

PREPARED	DRAWING NO.
DA/TM	306
DESIGNED	28000
ASHLEY	
DRAWN	
THORSON	
CHECKED	
02/15/01	
DATE	
	SHEET
	5
	of 28

ON MICROFILM

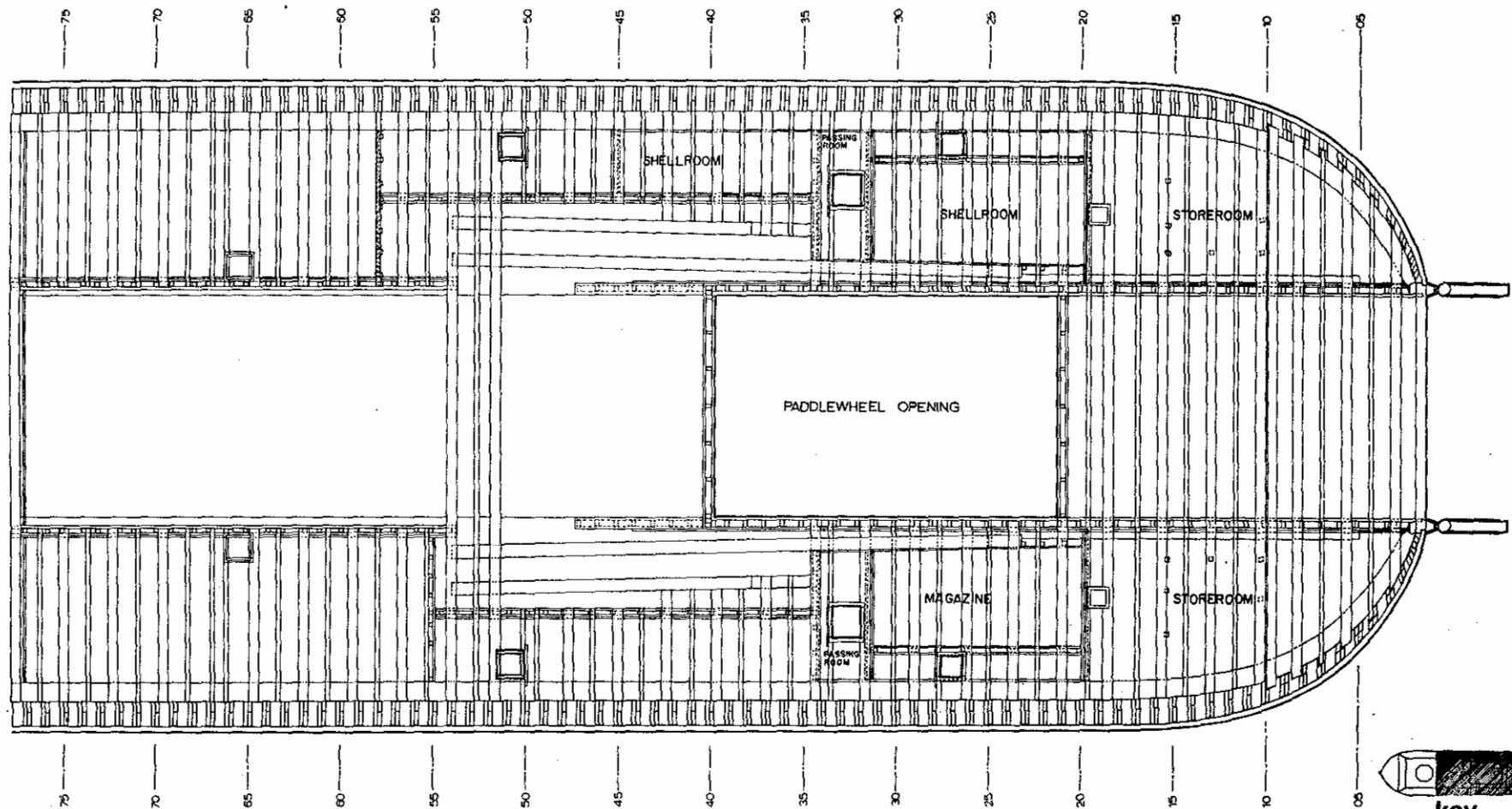

GUNDECK FRAMING - AFT

SCALE: 1/4"=1'-0"

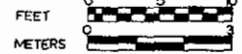

HISTORIC STRUCTURE REPORT



PREPARED BY	DRAWING NO.
DA/TM	306
REVISIONS	28000
ASHLEY	
SHAW	
THORSON	
CHERRY	
DATE	
	SHEET
	6
	OF 28

ON MICROFILM

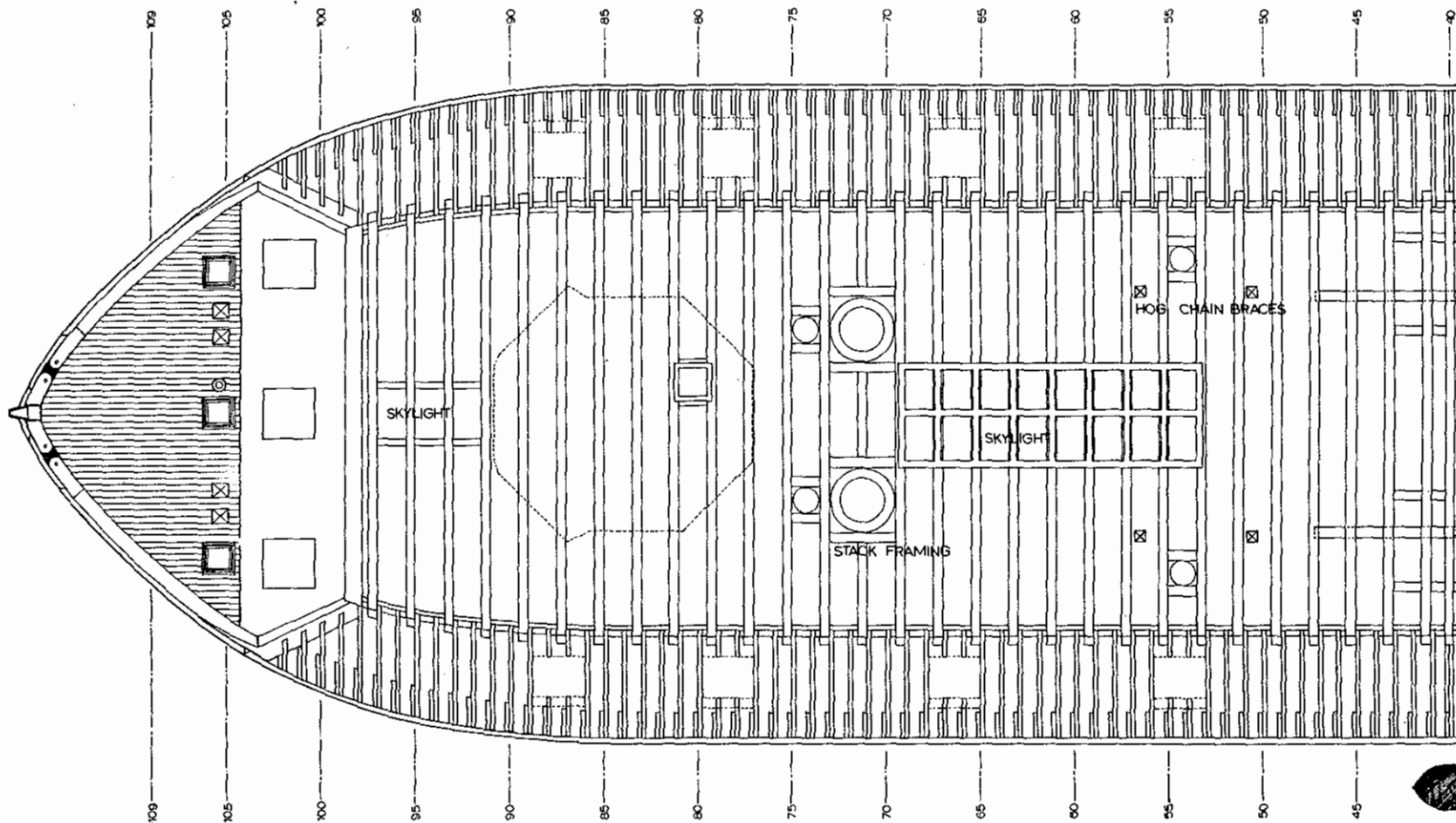

HURRICANE DECK FRAMING - FORWARD

SCALE: 1/4"=1'-0"

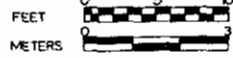

HISTORIC STRUCTURE REPORT

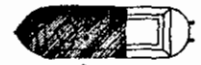

key

PREPARED DA/IN DESIGNED ASHLEY DRAWN THORSON CHECKED 02/18/03 DATE	DRAWING NO. 306 28000 PCIP 08 07 7 OF 23
--	---

ON MICROFILM

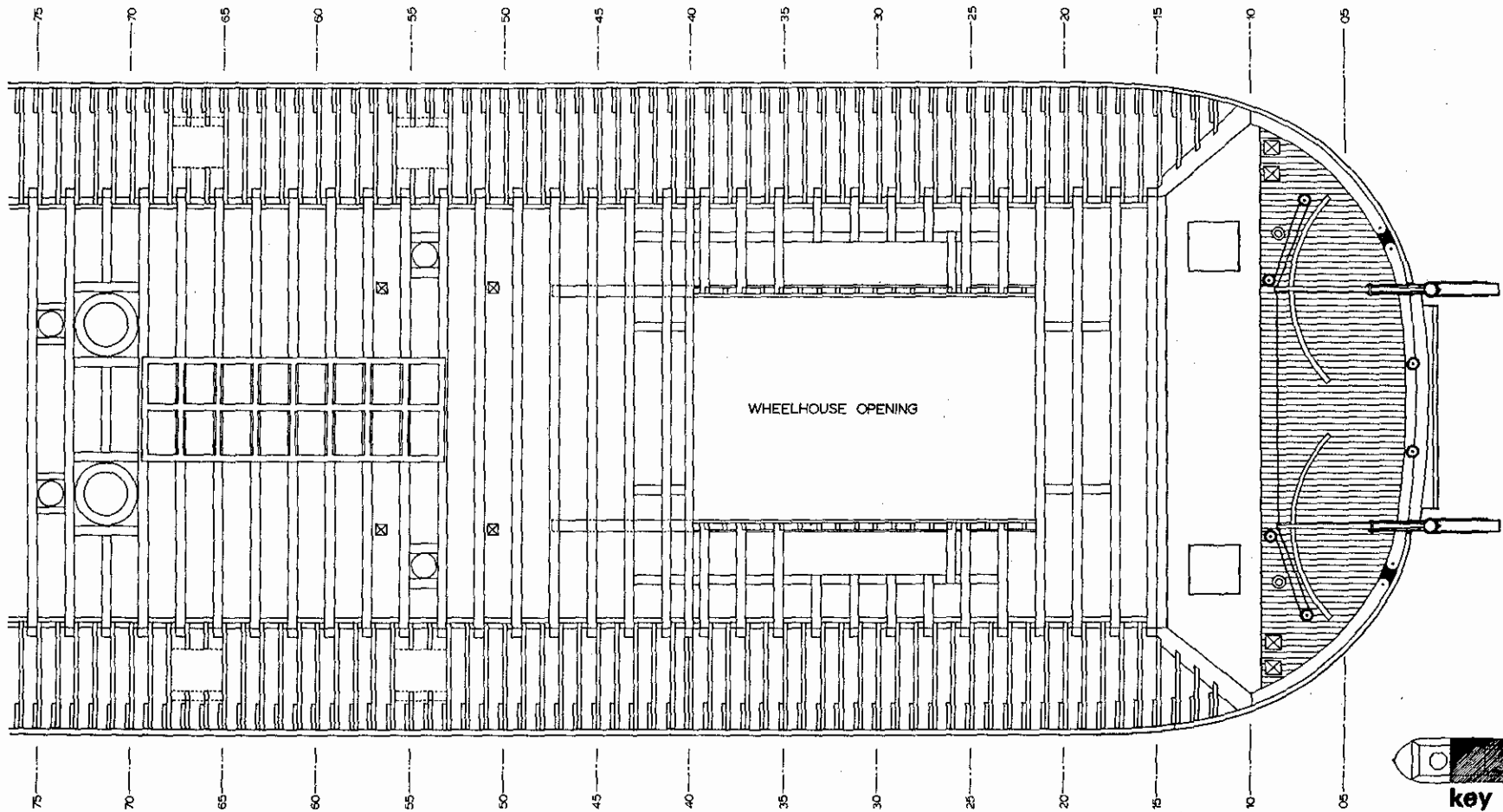

HURRICANE DECK FRAMING - AFT

SCALE: 1/4"=1'-0"

FEET
METERS

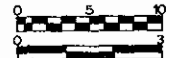

HISTORIC STRUCTURE REPORT

ON MICROFILM



key

PREPARED	DRAWING NO.
DA/TM	306
DESIGNED	28000
ASHLEY	PLOT
TRINNY	DATE
THORSON	CHECKED
DRAWN	DATE
	SHEET
	8
	OF 32

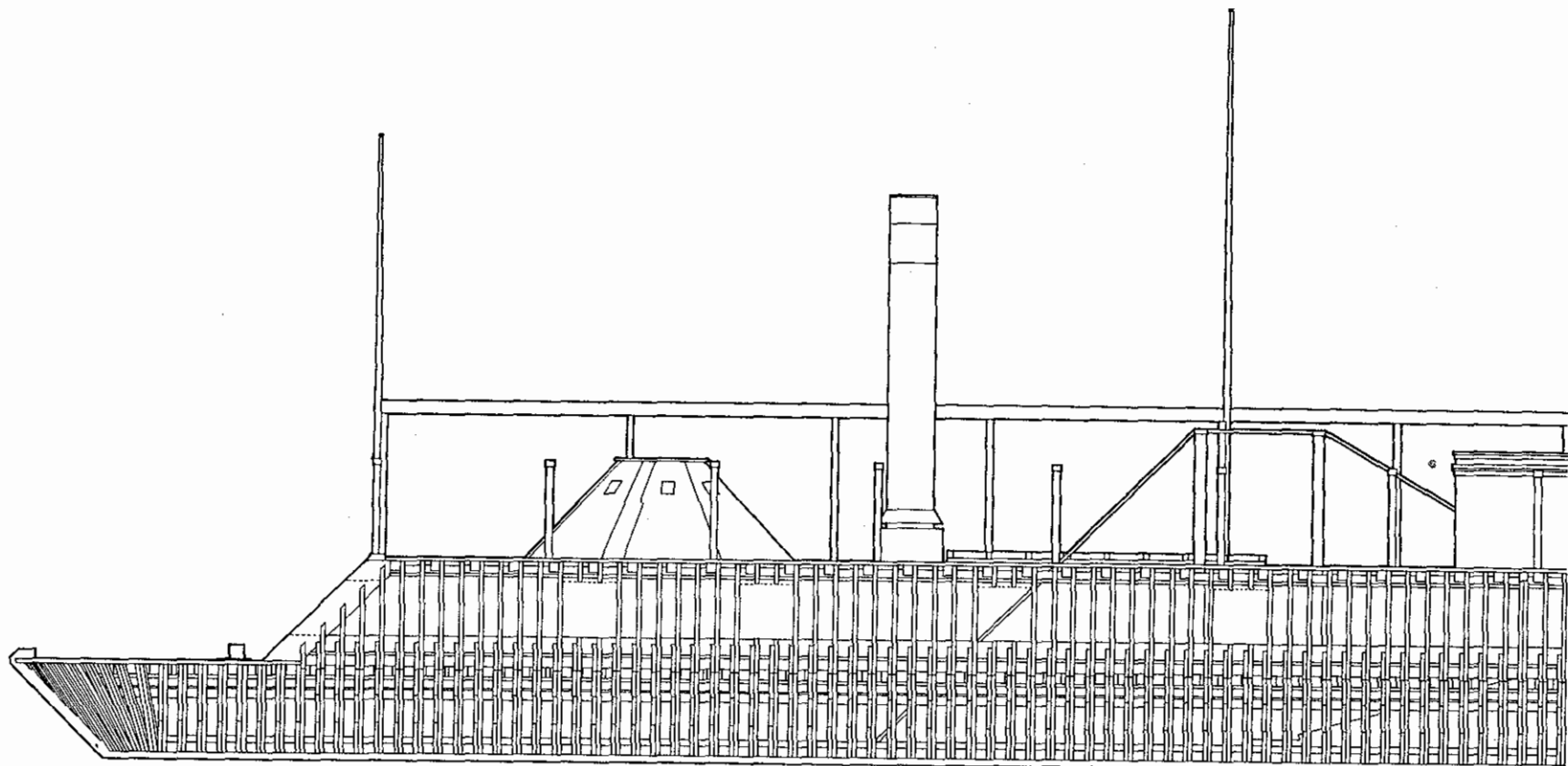

109 105 100 95 90 85 80 75 70 65 60 55 50 45



key

PORT HULL FRAMING ELEVATION - FORWARD

SCALE: 1/4" = 10'

HISTORIC STRUCTURE REPORT

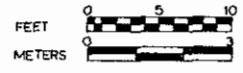

PREPARED DA/TM RESTORED	DRAWING NO. 306 28000
ASHLEY DRAWN	PCIP 891
T. JOHNSON CHECKED	SHEET 9
02/16/81 DATE	OF 23

ON MICROFILM

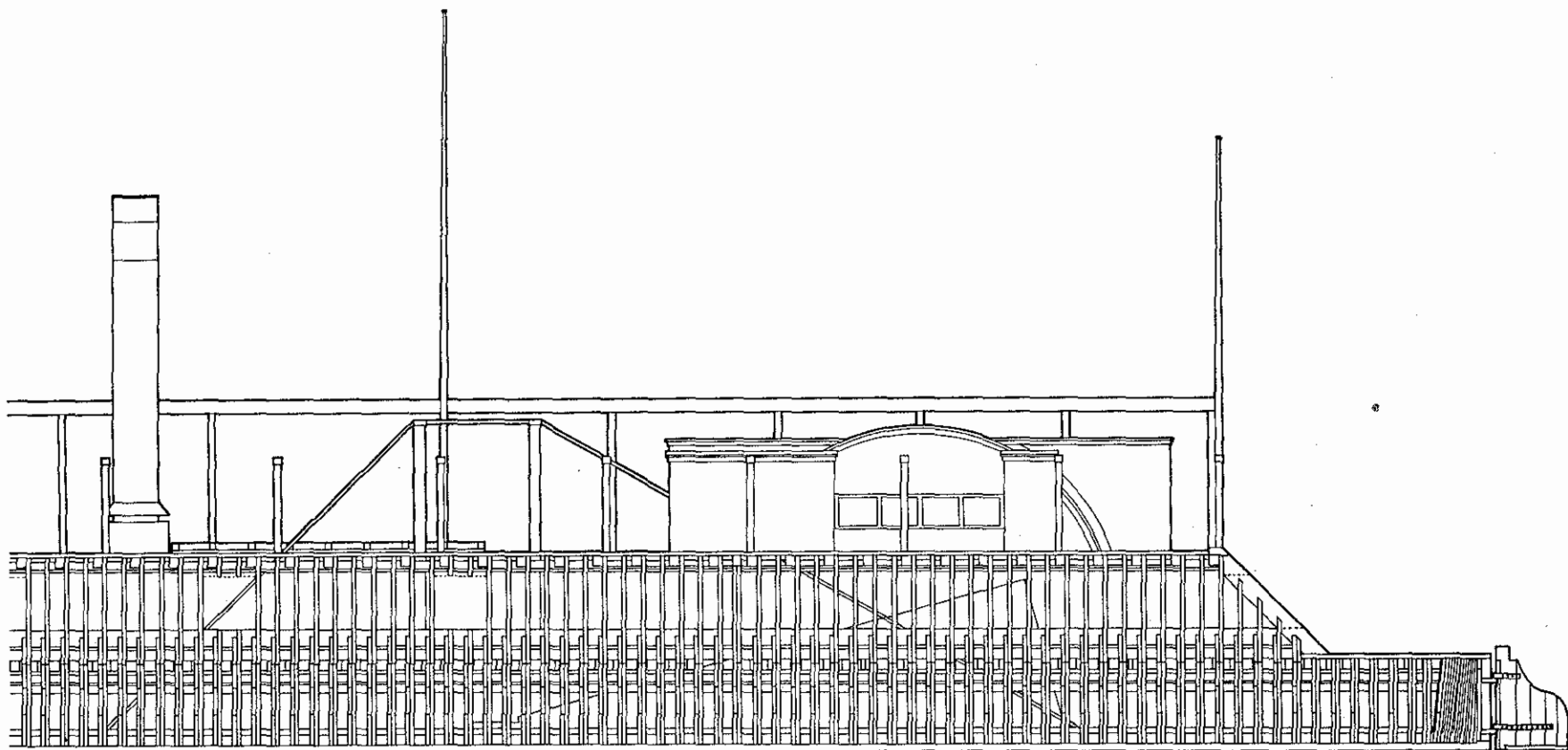

75 70 65 60 55 50 45 40 35 30 25 20 15 10 05



key

PORT HULL FRAMING ELEVATION - AFT

SCALE: 1/4" = 1'-0"

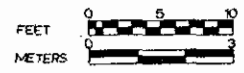

HISTORIC STRUCTURE REPORT

PREPARED	DRAWING NO.
DA 7/4	308
DESIGNED	26000
ASHLEY	
DRAWN	
THORSON	
CHECKED	
02/06/81	
DATE	
	SHEET
	10
	OF 23

ON MICROFILM

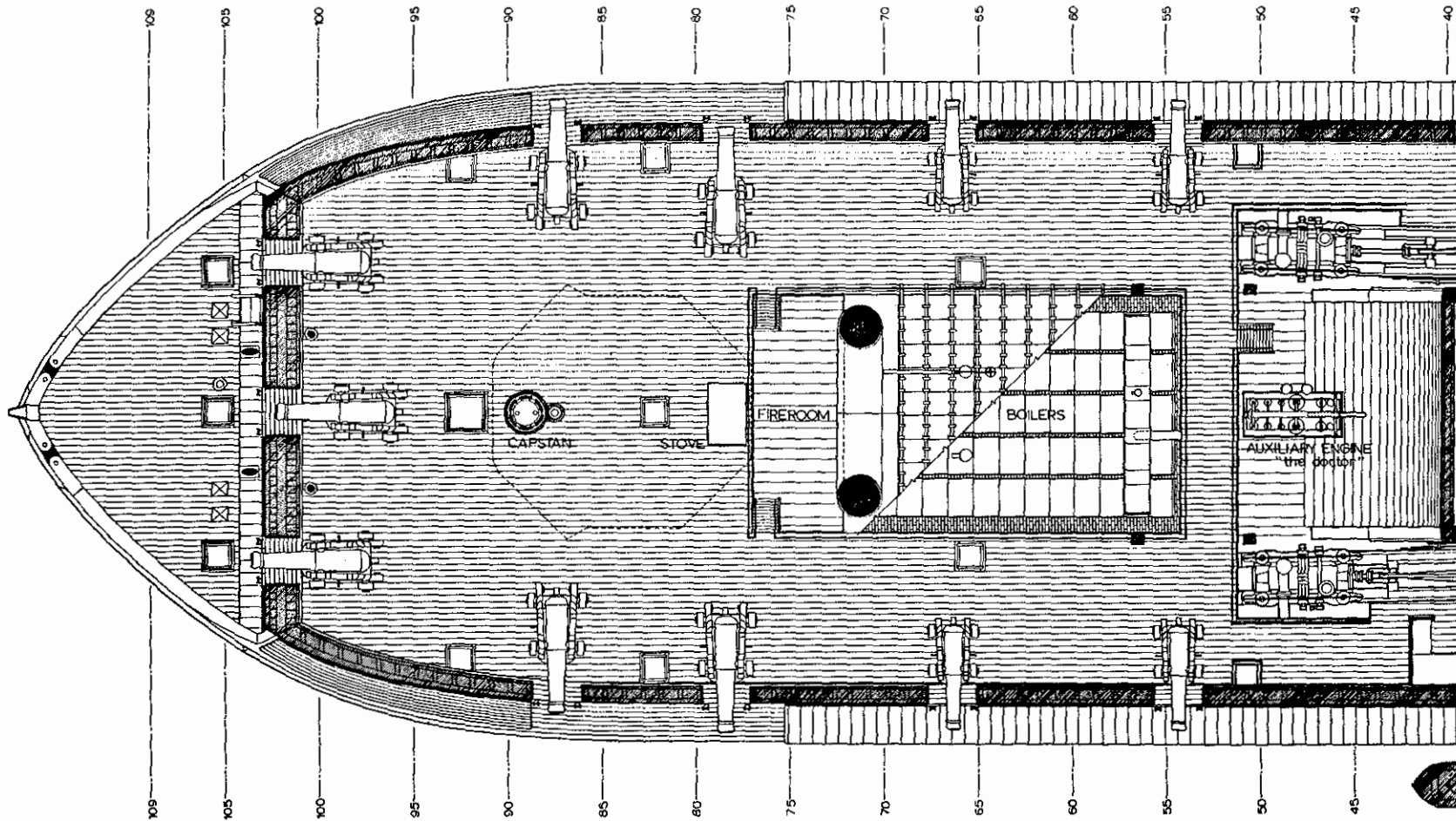

GUNDECK PLAN / SECTION - FORWARD

SCALE: 1/4"=10'

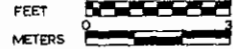

HISTORIC STRUCTURE REPORT



key

PREPARED DA/TM DESIGNED ASHLEY DRAWN THORSON CHECKED CR/HR/81 DATE	DRAWING NO. 308 28000	SHEET 11 OF 22
--	-----------------------------	----------------------

ON MICROFILM

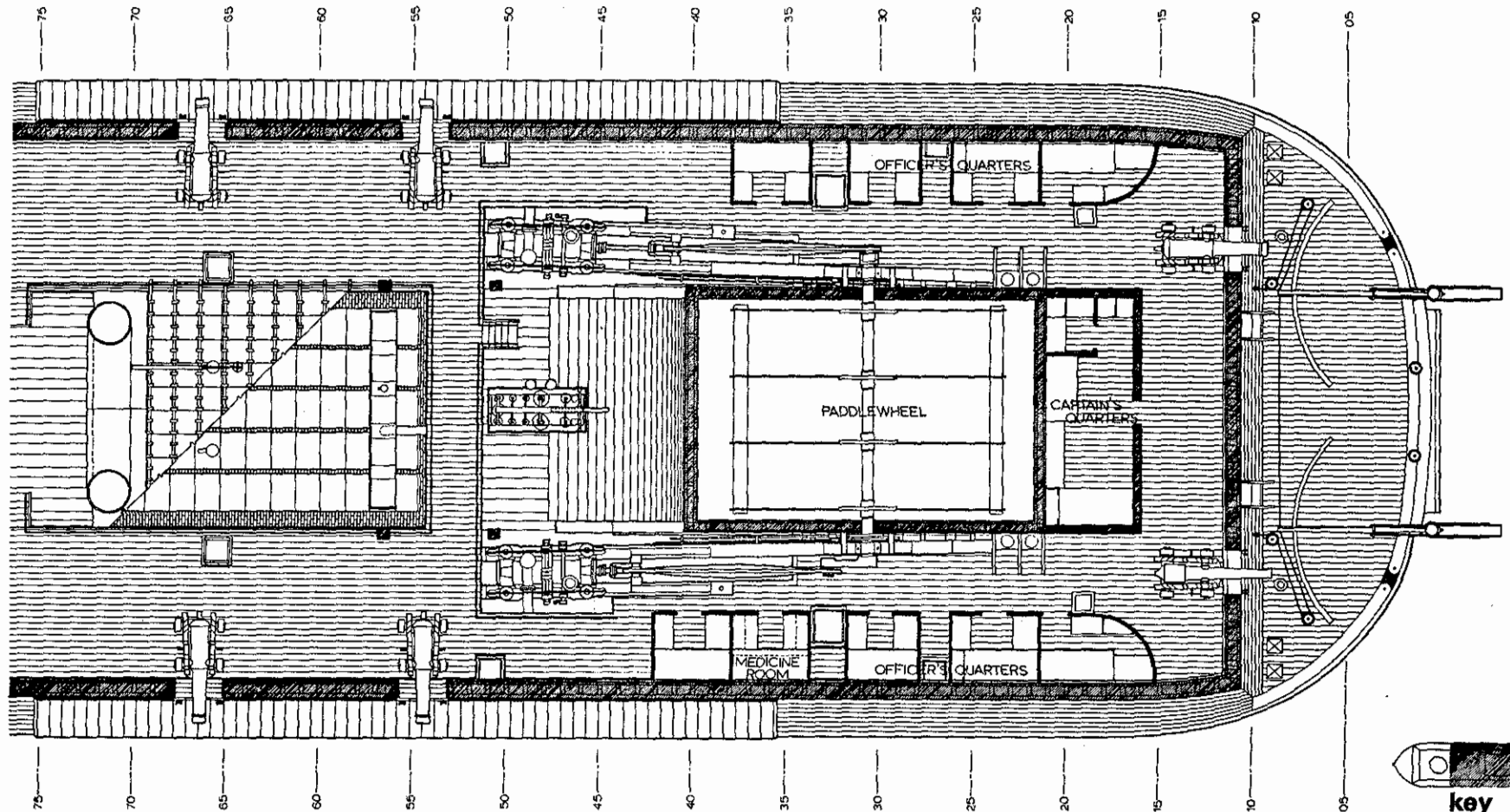

GUNDECK PLAN / SECTION - AFT SCALE: 1/4"=1'-0"

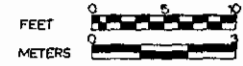

HISTORIC STRUCTURE REPORT



key

PREPARED BY DA/TM REDFORD ASHLEY DRAWN BY T. JOHNSON CHECKED BY GZ/18/CR DATE	DRAWING NO. 300 28000 SHEET 12 OF 22
---	---

ON MICROFILM

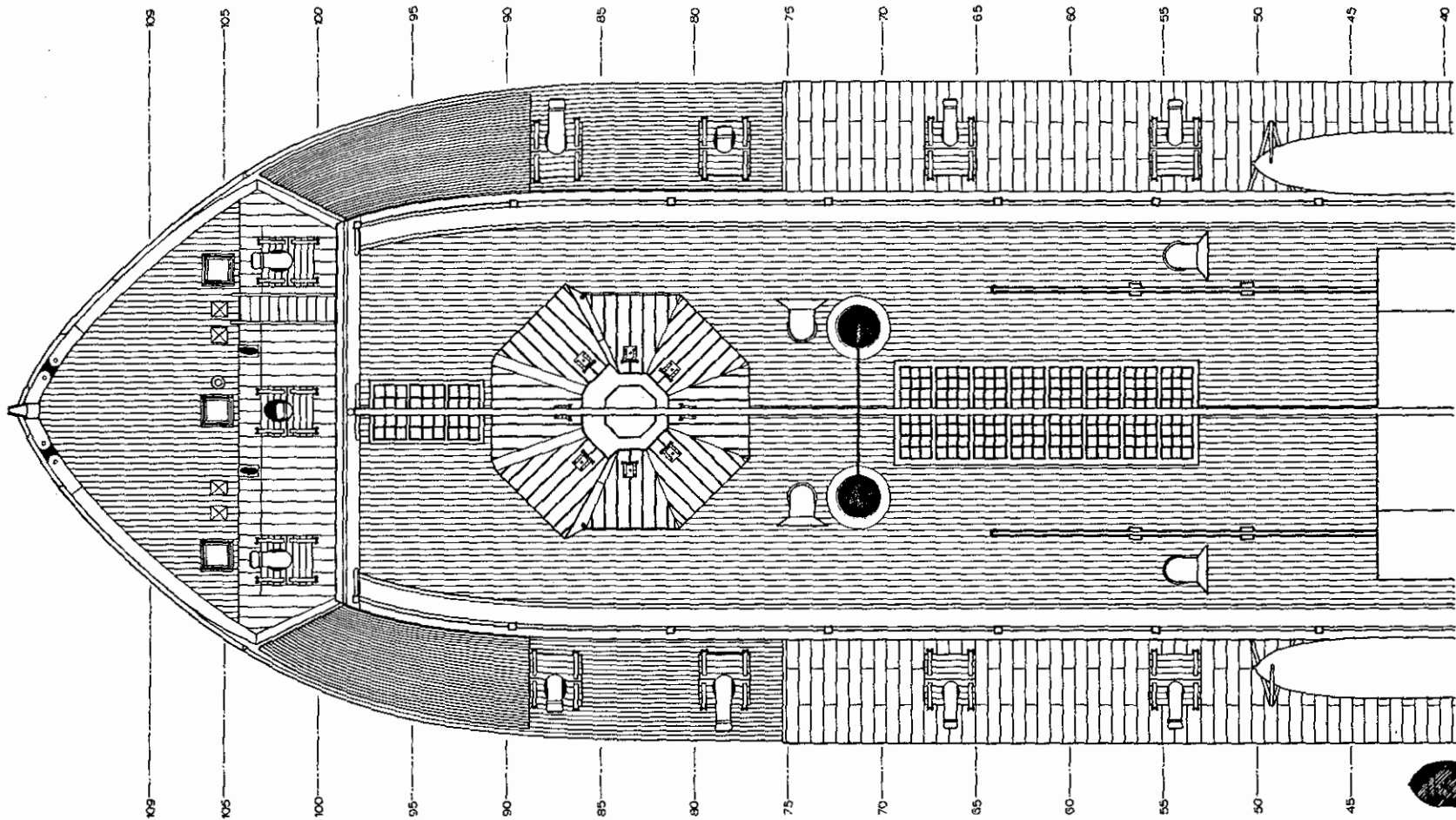

HURRICANE DECK PLAN - FORWARD

SCALE: 1/4"=1'-0"

FEET

METERS

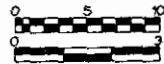

HISTORIC STRUCTURE REPORT

key



PREPARED	DRAWING NO.
DAY/TM	305
DESIGNED	28000
ASHLEY	
DRAWN	
THORSON	
CHECKED	
DATE	
	SHEET
	13
	OF 29

ON MICROFILM

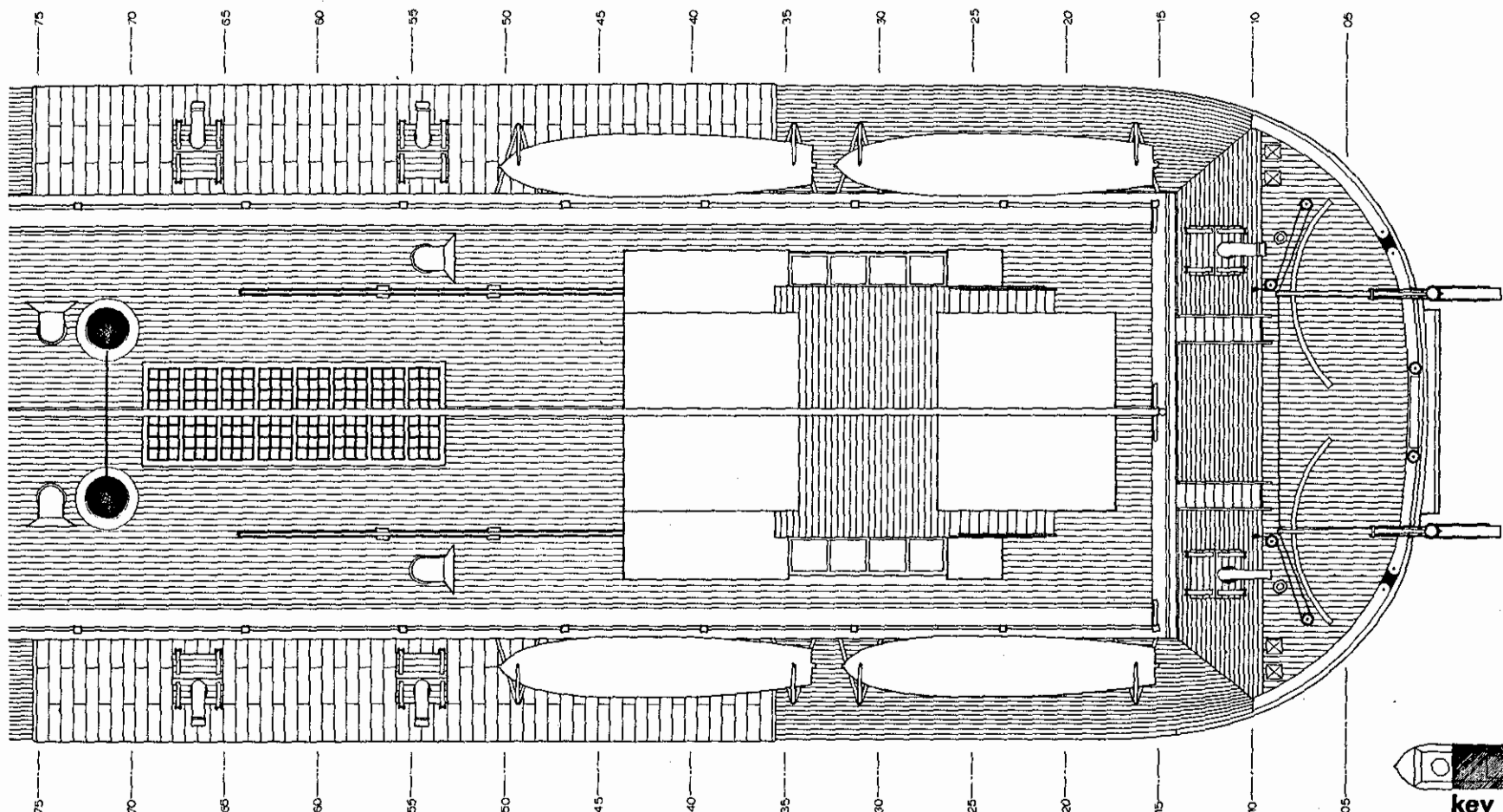

HURRICANE DECK PLAN - AFT

SCALE: 1/4"=10'

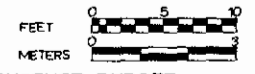

key

HISTORIC STRUCTURE REPORT

PREPARED BY DA/TM	DRAWING NO. 306
DESIGNED BY ASHLEY	28000
DRAWN BY THORSON	14
CHECKED BY DATE	OF 22

ON MICROFILM

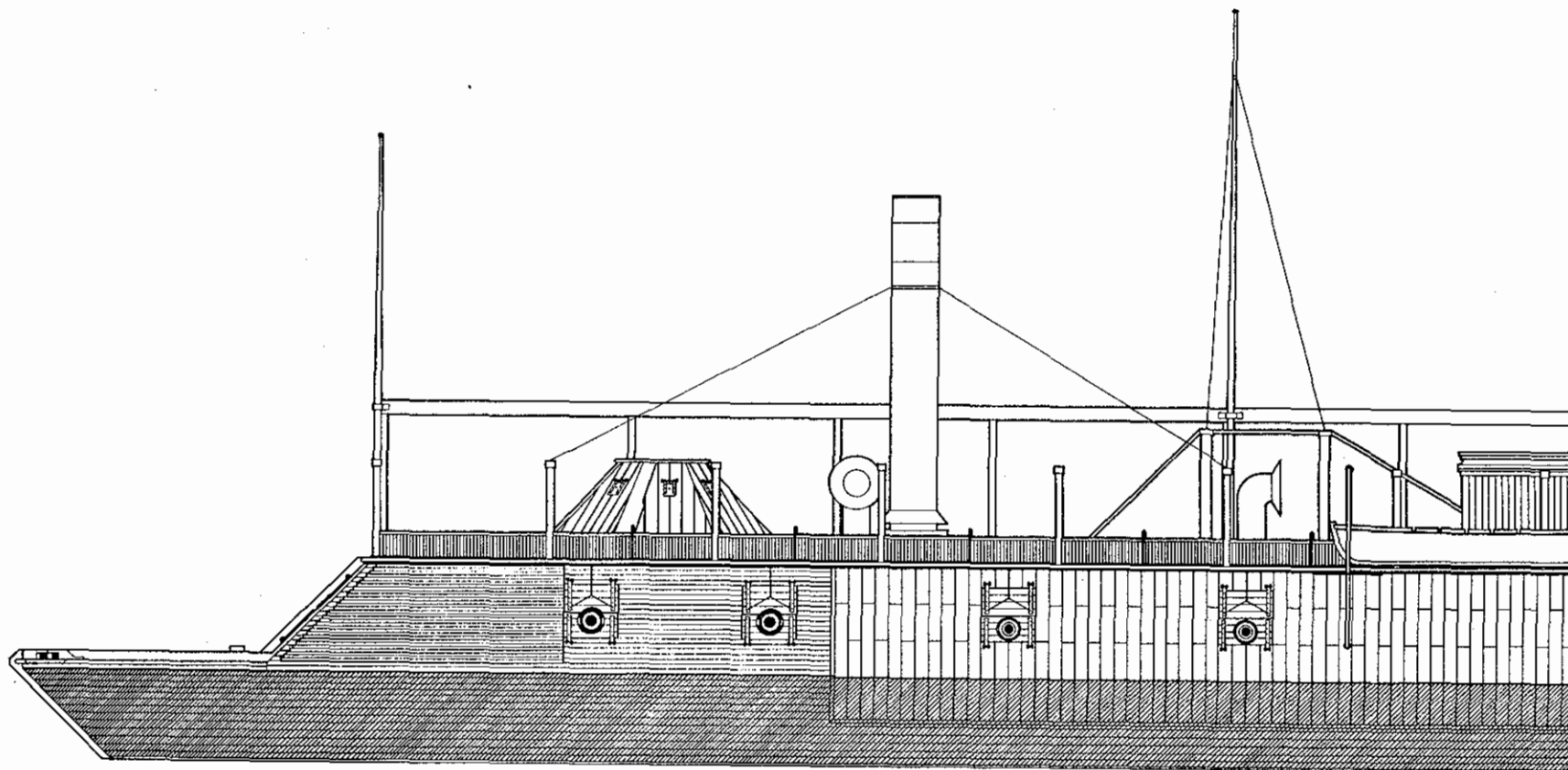

109 105 100 95 90 85 80 75 70 65 60 55 50 45

PORT ELEVATION - FORWARD

SCALE: 1/4" = 10'



key

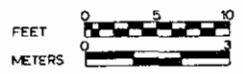

HISTORIC STRUCTURE REPORT

PREPARED	DRAWING NO.
DA/TM	306
DESIGNED	28000
ASHLEY	
DRAWN	
THORSON	
CRUZED	
02/16/24	
DATE	
	SHEET
	15
	OF 22

ON MICROFILM

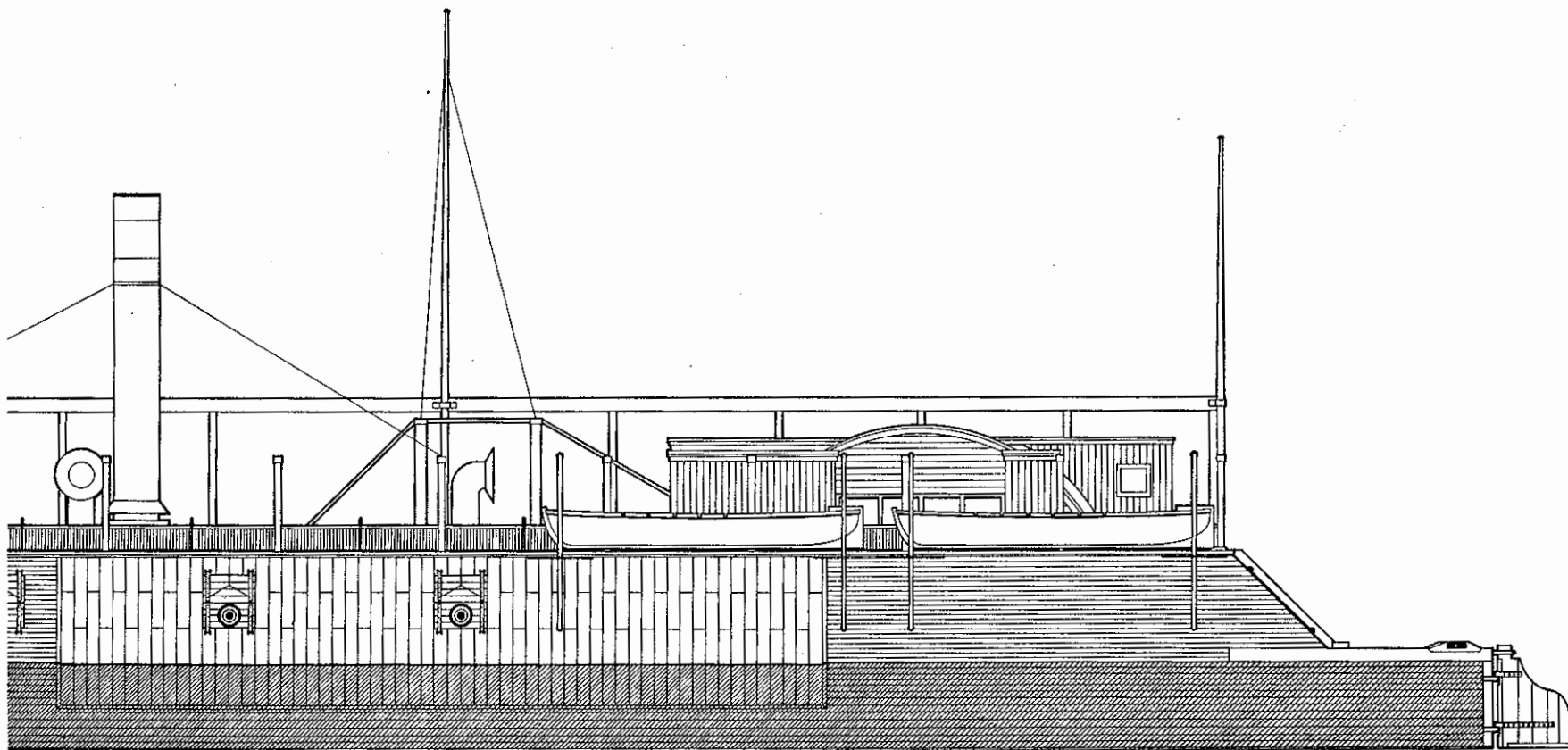

75 70 65 60 55 50 45 40 35 30 25 20 15 10 05



key

PORT ELEVATION - AFT

SCALE: 1/4"=1'-0"

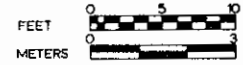

HISTORIC STRUCTURE REPORT

PREPARED	DRAWING NO.
DA/TM	206
DESIGNED	28000
ASHLEY	
DRUM	
THORSON	
ENGINEER	
DATE	
	SHEET
	16
	of 22

ON MICROFILM

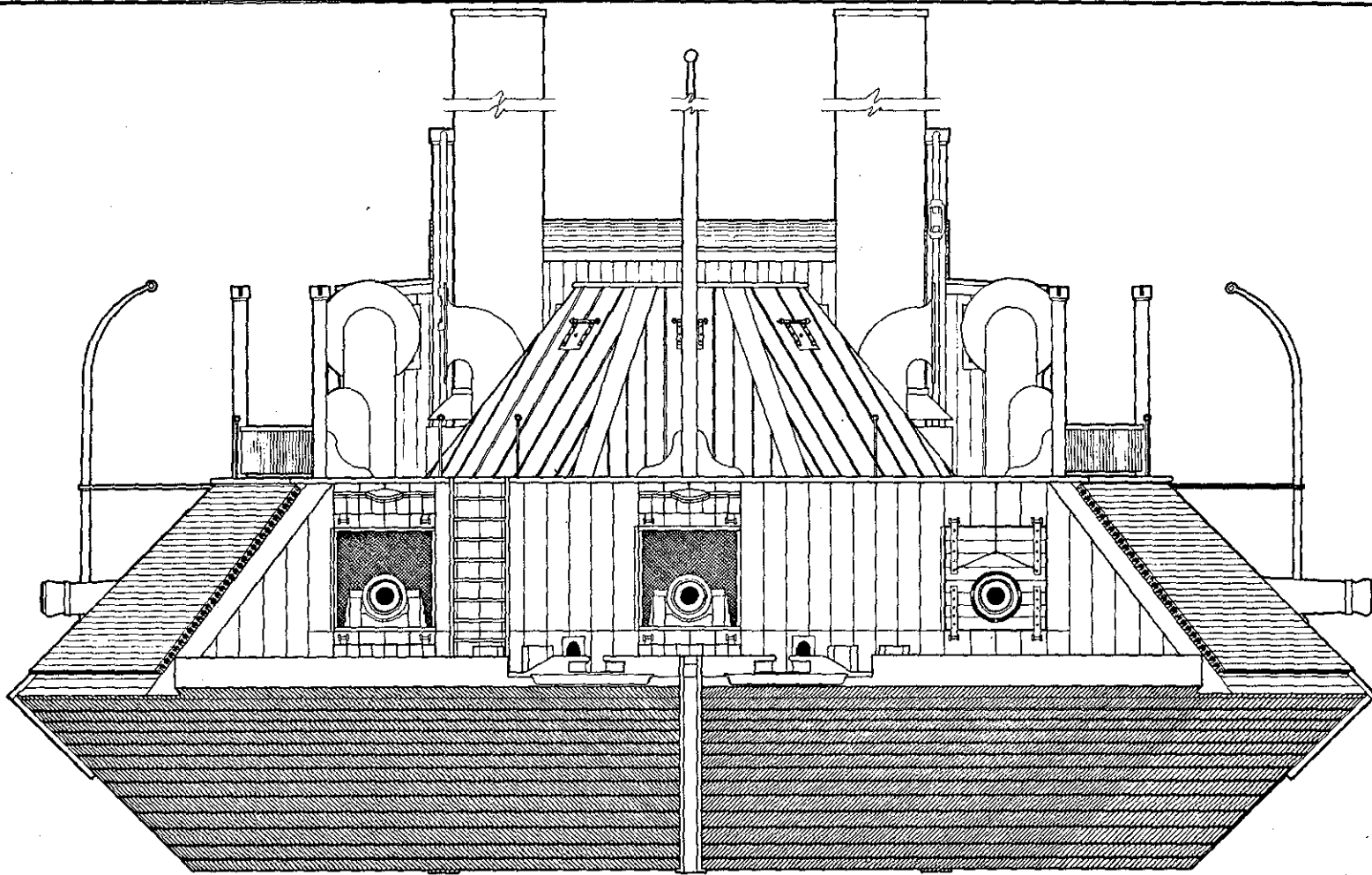

BOW ELEVATION

SCALE: 1/2"=1'-0"

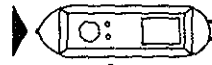

key

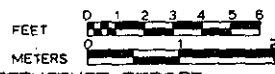

HISTORIC STRUCTURE REPORT

PREPARED DA/TM DESIGNED ASHLEY DRAWN THORSON CHECKED DATE	DRAWING NO. 306 28000	SHEET 17 OF 22
--	-----------------------------	----------------------

ON MICROFILM

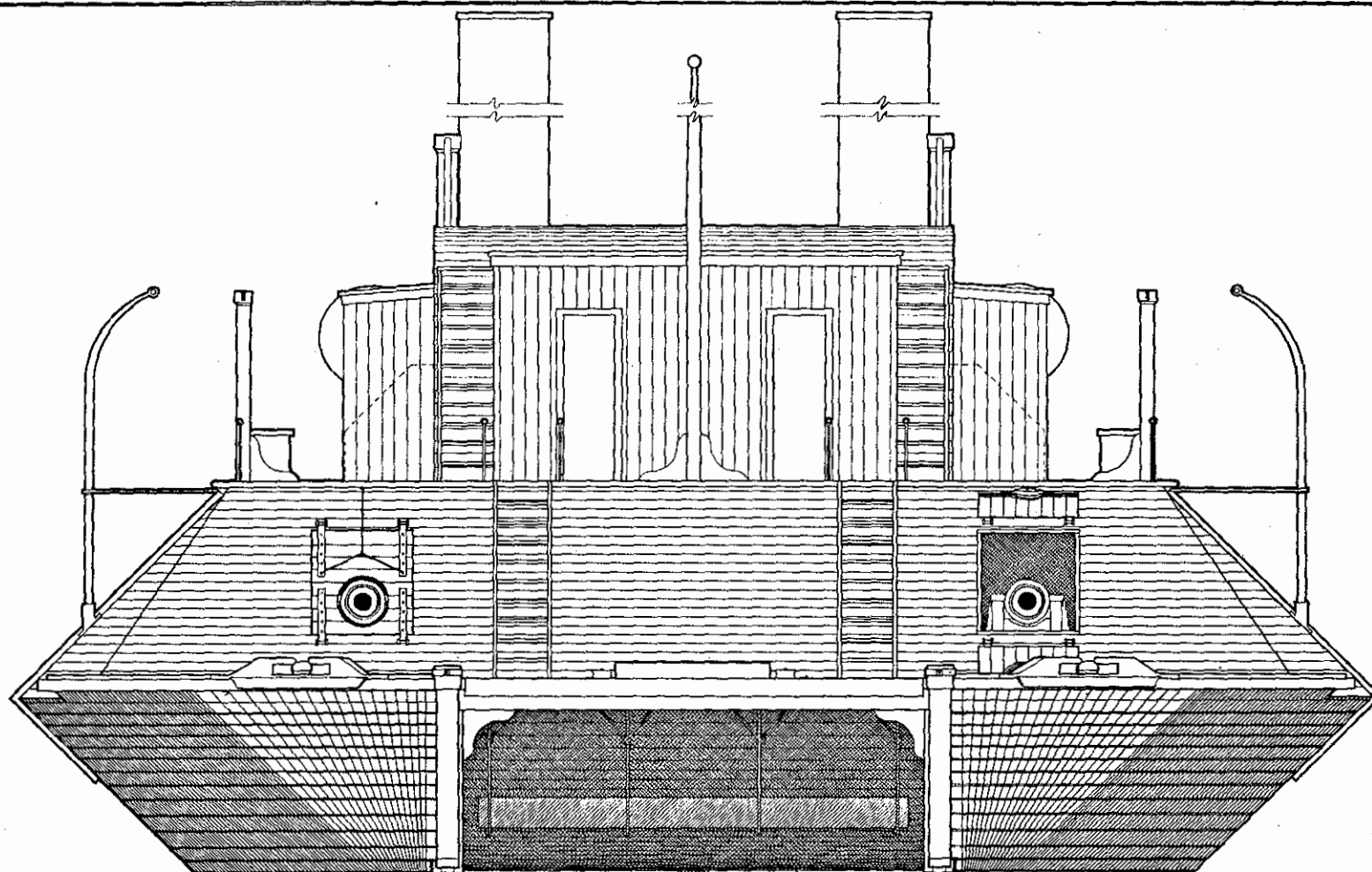

STERN ELEVATION

SCALE: 1/2"=1'-0"

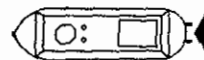

key

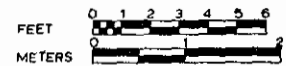

HISTORIC STRUCTURE REPORT

PREPARED	DATE	DRAWING NO.	SHEET
DAVID M.	1966	28000	18
REVIEWED	DATE		
ASHLEY	1966		
DRAWN	DATE		
THOMPSON	1966		
CHECKED	DATE		
DE/18/W	1966		

ON MICROFILM

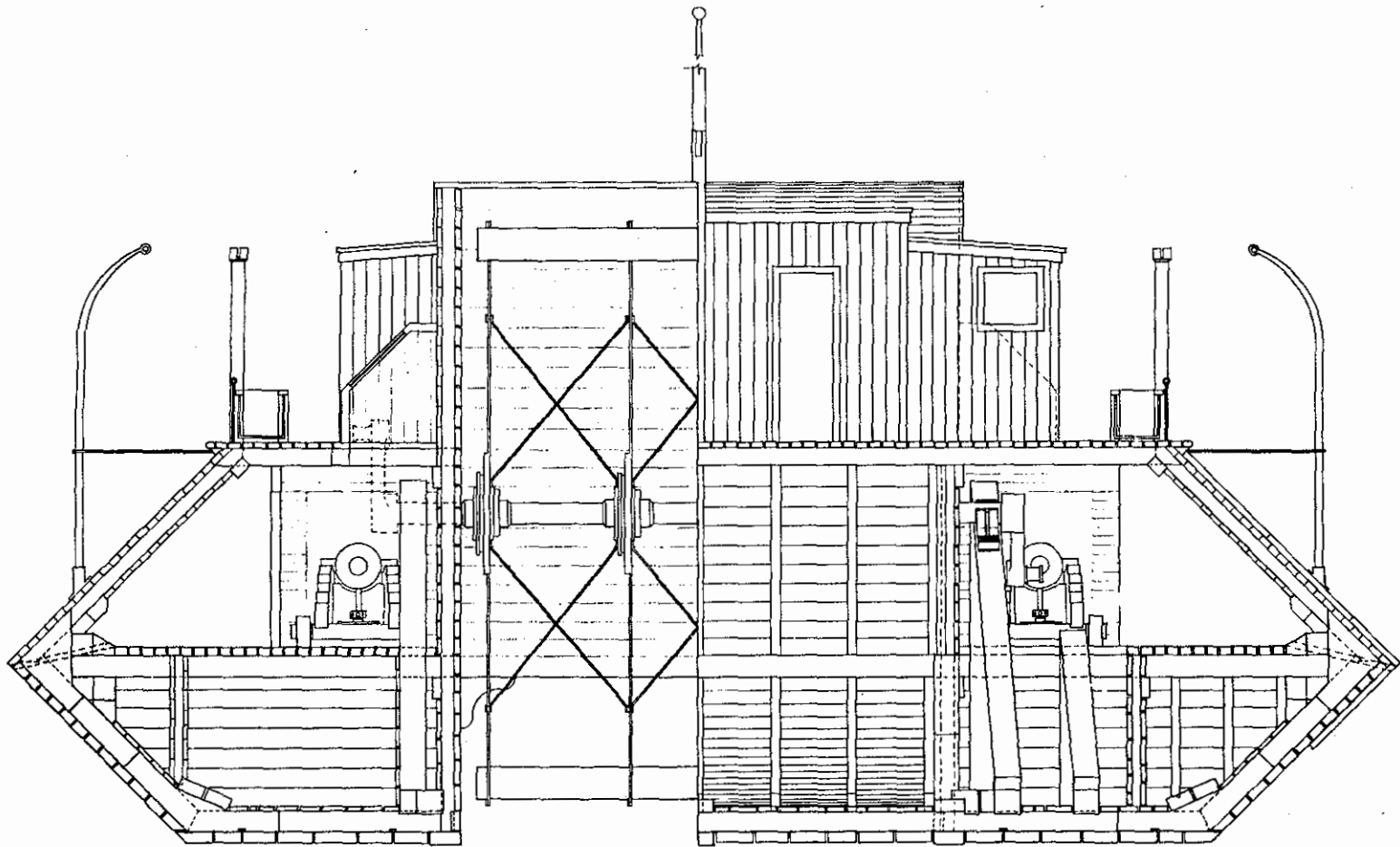

frame # 25

frame # 50



key

LATERAL SECTION

SCALE: 1/2"=1'-0"

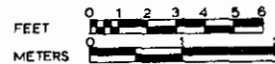

HISTORIC STRUCTURE REPORT

PREPARED	DRAWING NO.
DA/TM	306
DESIGNED	28000
AS BUILT	PROP. BY
THORSON	19
CHECKED	OF 22
02/18/81	
DATE	

ON MICROFILM

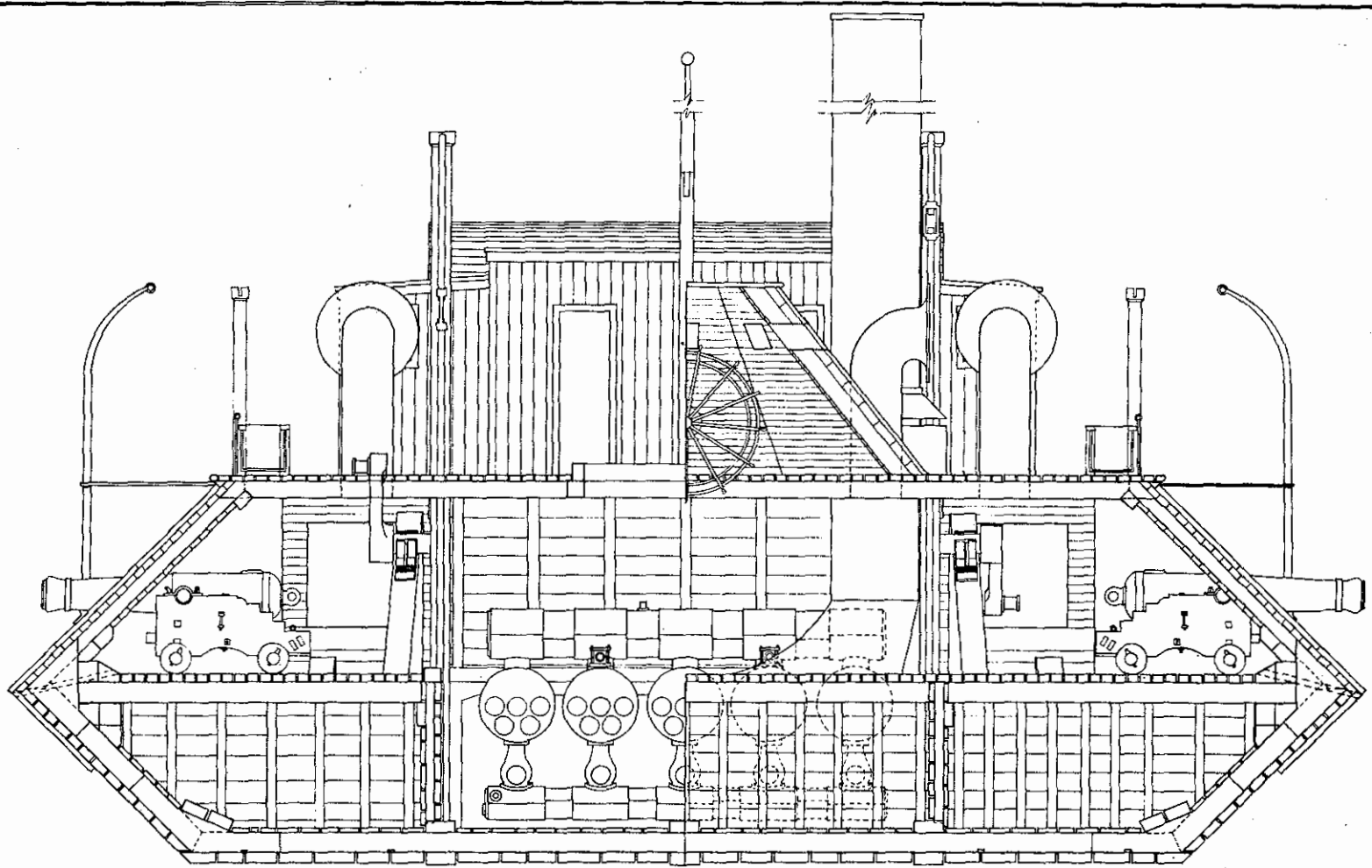

frame # 72

frame # 84

LATERAL SECTION

SCALE: 1/2"=10'

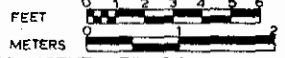
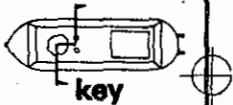

HISTORIC STRUCTURE REPORT

PREPARED DA/TM DESTROYED ASHLEY DRAWN LUCASON CHECKED 02/18/84 DATE	DRAWING NO. 308 25000	SHEET 20 OF 28
---	-----------------------------	----------------------

ON MICROFILM

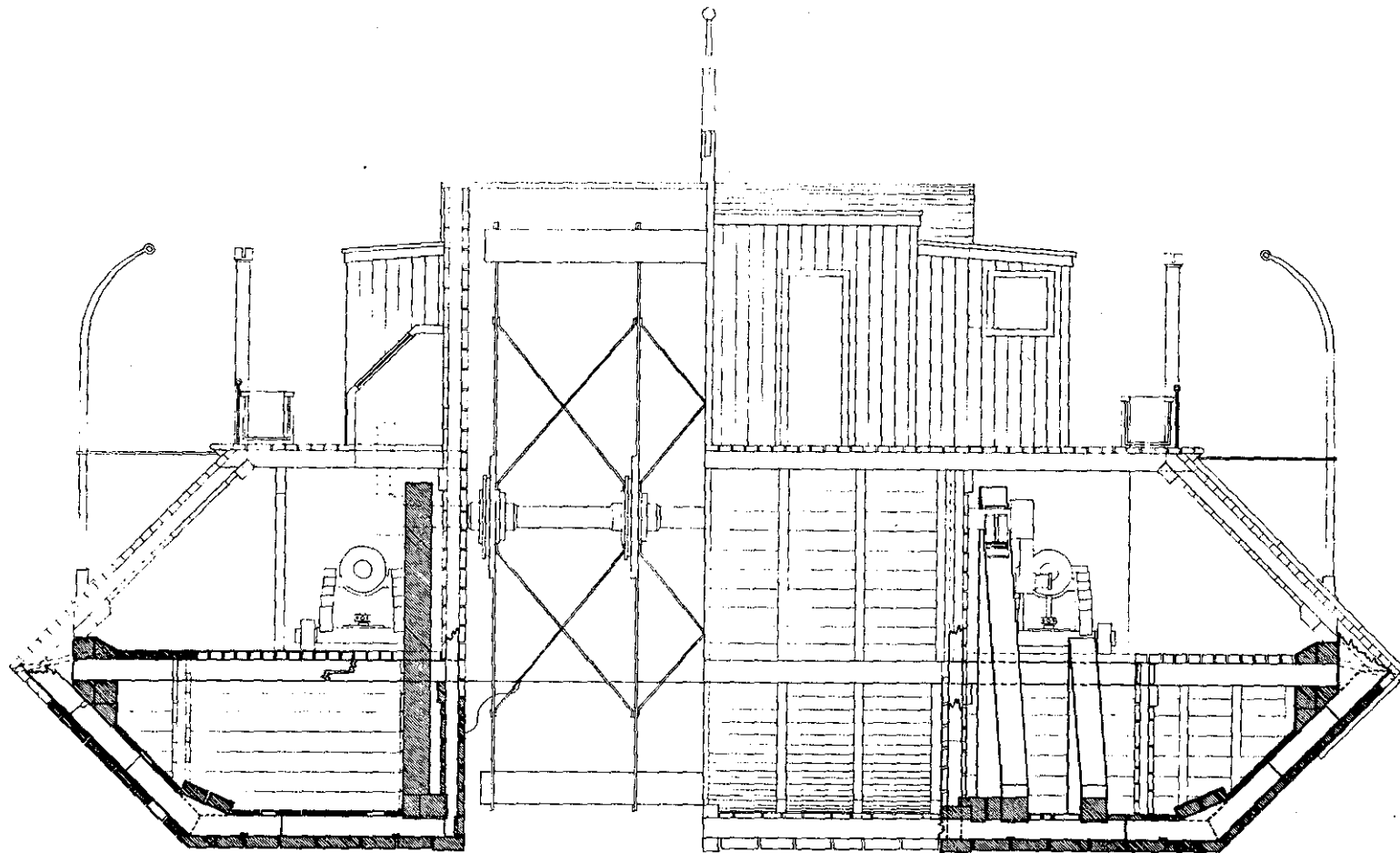

frame # 25

frame # 50

SECTION COMPOSITE SHOWING
EXISTING FABRIC

LATERAL SECTION

SCALE: 1/2" = 1'-0"

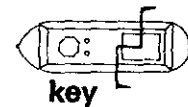

key

FEET



METERS



HISTORIC STRUCTURE REPORT

PREPARED ASHLEY DESIGNED ASHLEY DRAWN THORSON CHECKED DATE	DRAWING NO. 306 28000 DATE BY 21 OF 22
---	--

ON MICROFILM

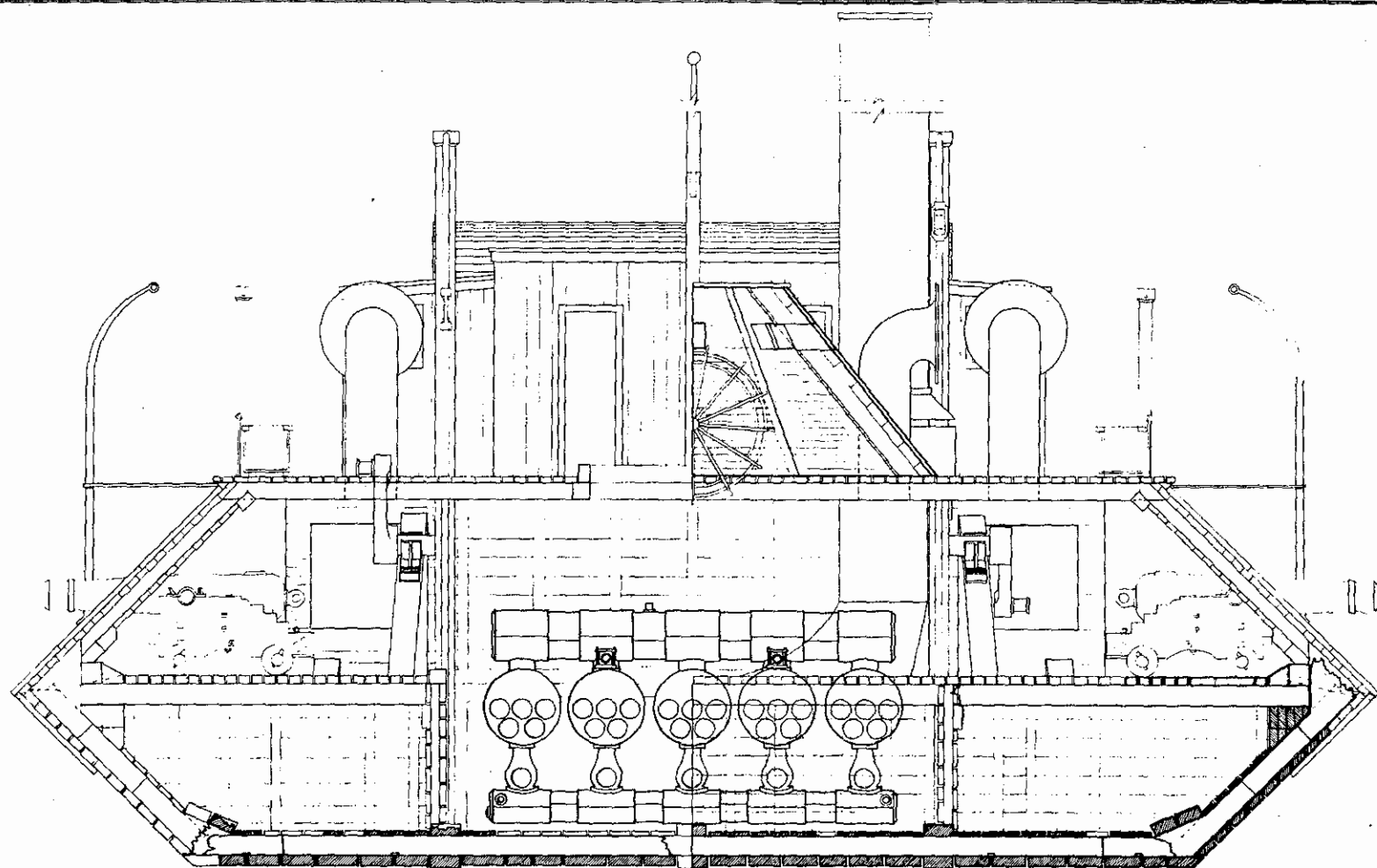

frame # 72

frame # 84

SECTION COMPOSITE SHOWING
EXISTING FABRIC

LATERAL SECTION

SCALE: 1/2" = 10'

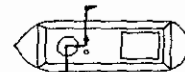

key

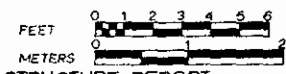

HISTORIC STRUCTURE REPORT

PREPARED	DRAWING NO.
ASHLEY DESIGNED	305
ASHLEY DRAWN	28000
THORSON CHECKED	DATE
UNIT	02/16/58
	SHEET
	22
	OF 22

ON MICROFILM

LARGE CARRIAGE to fit:
8" smoothbores
42 pounder rifles

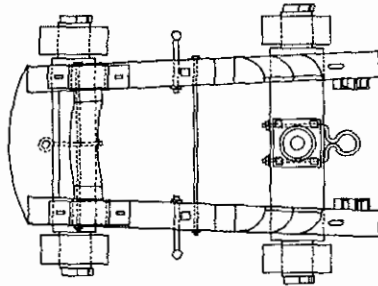

SMALL CARRIAGE to fit:
32 pounder smoothbores
30 pound parrot rifle

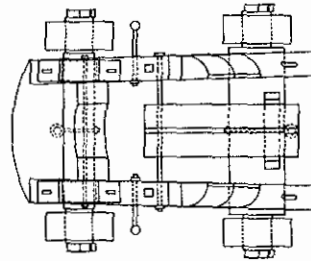

PLANS

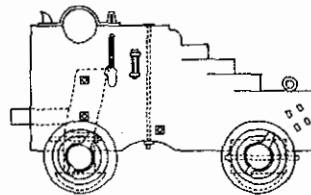
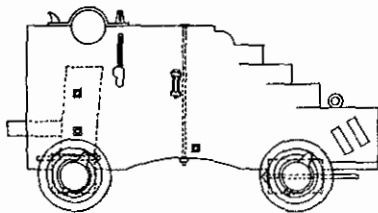

ELEVATIONS

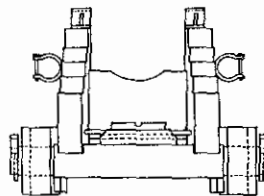
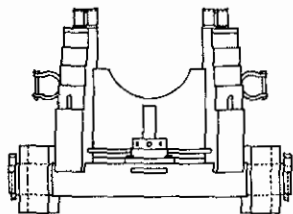

GUN CARRIAGES & TUBES

SCALE: 1"=1'-0"

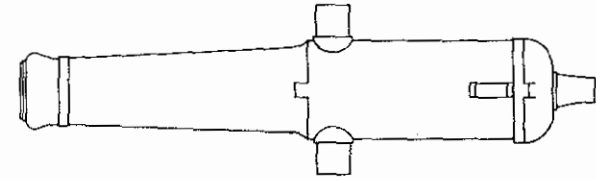

8 INCH SMOOTHBORE - 63 HUNDREDWEIGHT

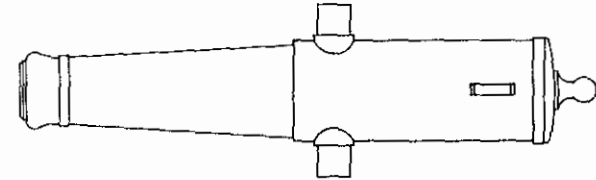

ARMY 42 POUNDER - RIFLED

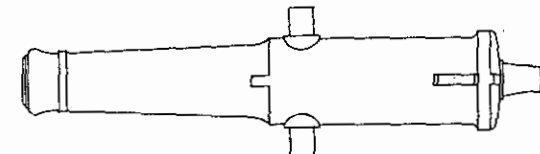

32 POUNDER SMOOTHBORE - 42 HUNDREDWEIGHT

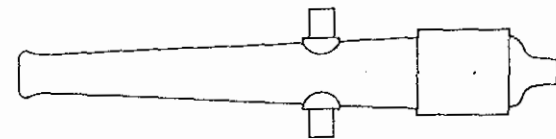

30 POUND NAVY PARROT RIFLE

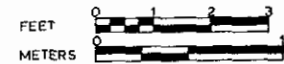

HISTORIC STRUCTURE REPORT

PREPARED	DA/TM	DRAWING NO.
DESIGNED	306	306
DRAWN	28000	
THORSON		SHEET
02/15/09		23
DATE		OF 28

ON MICROFILM

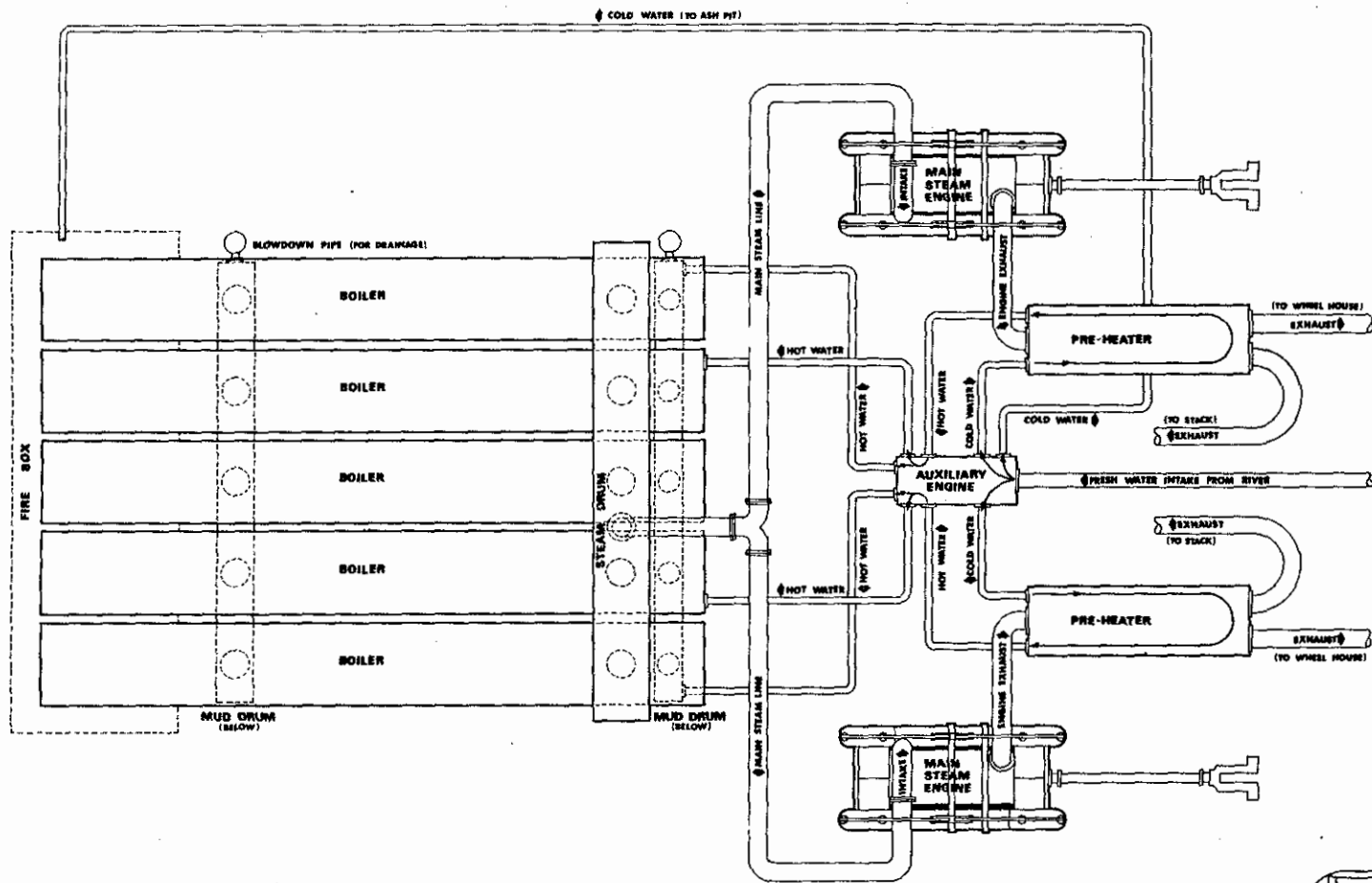

PROPULSION SYSTEM SCHEMATIC N.T.S.



key

PREPARED	DRAWING NO.
DA/TM	306
DESIGNED	26000
ASHLEY	PREP
BY	107
THORSON	SHEET
CHECKED	24
DATE	OF 28

HISTORIC STRUCTURE REPORT

ON MICROFILM

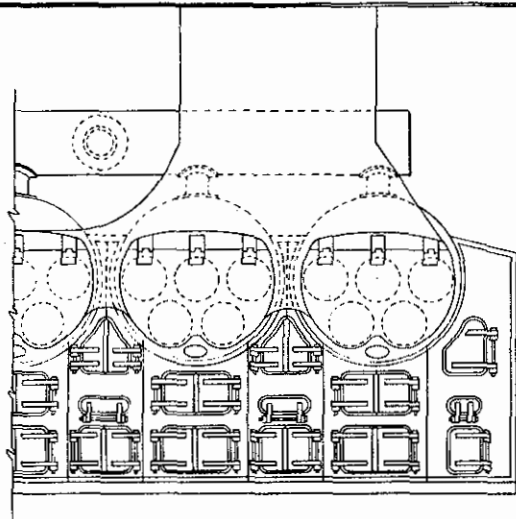

1/2 forward elevation SCALE: 3/4"-1'-0"
 (AS DESIGNED)
 BASIC DATA FROM NATIONAL ARCHIVES RECORD GROUP 52

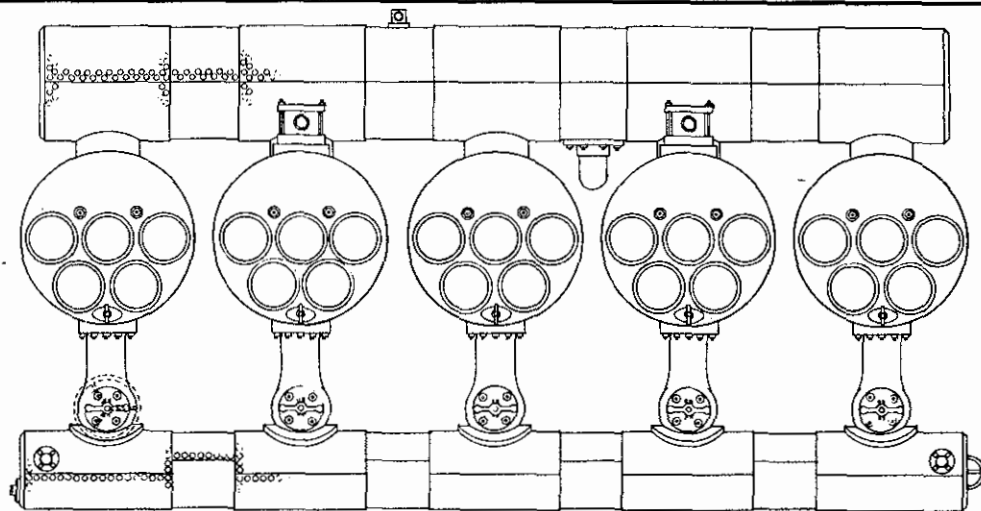

lateral elevation - forward SCALE: 1"-1'-0"
 (AS BUILT)

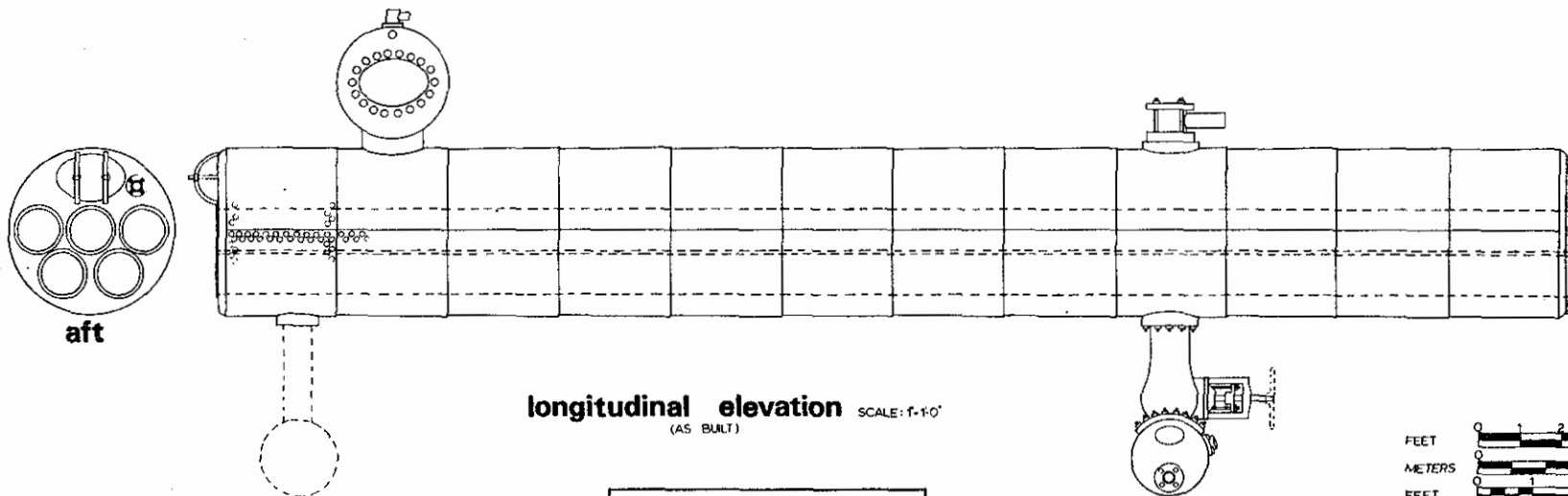

longitudinal elevation SCALE: 1"-1'-0"
 (AS BUILT)

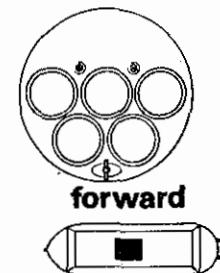

key

BOILER DETAILING

SCALE VARIES

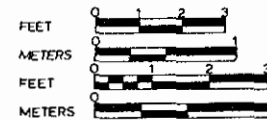

HISTORIC STRUCTURE REPORT

PREPARED BY	DA/TM	DRAWING NO.	206
DESIGNED BY	ASHLEY	CHECKED BY	25000
DRAWN BY	THORSON	SHEET NO.	25
DATE	02/18/83	OF 22	

CN MICROFILM

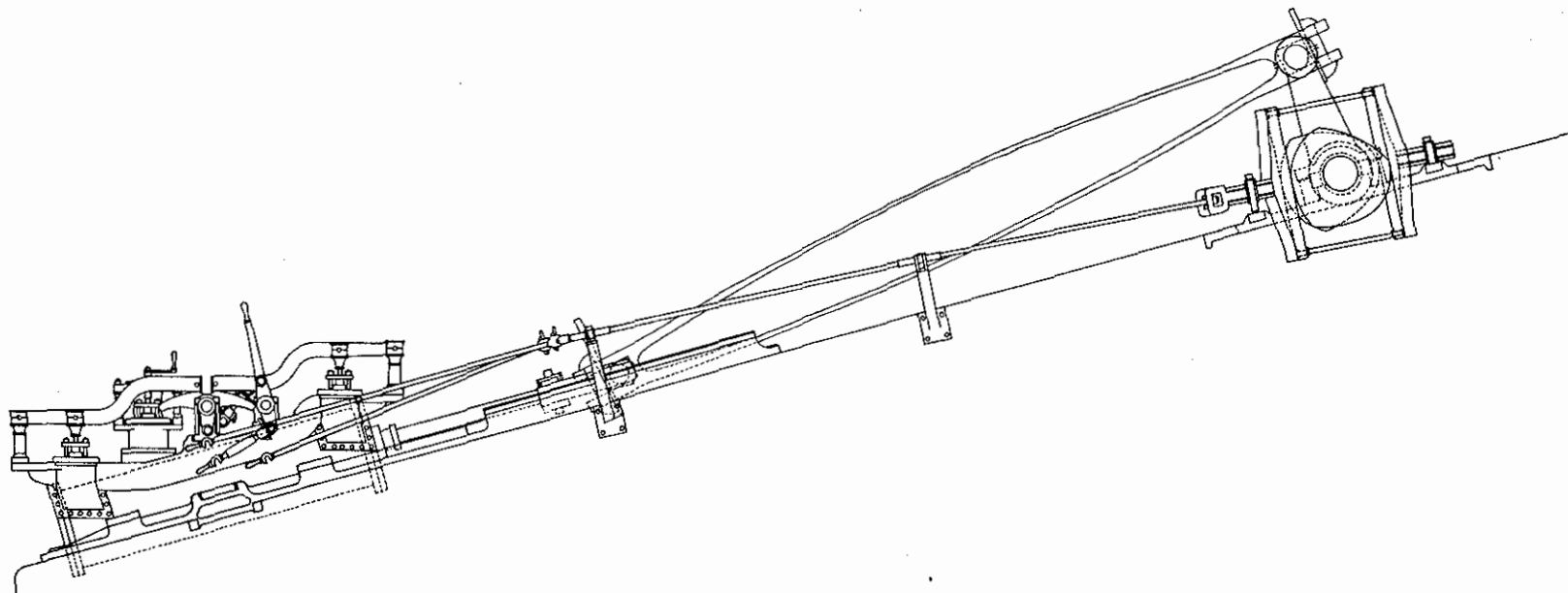

elevation

HULL CEILING ELEVATION

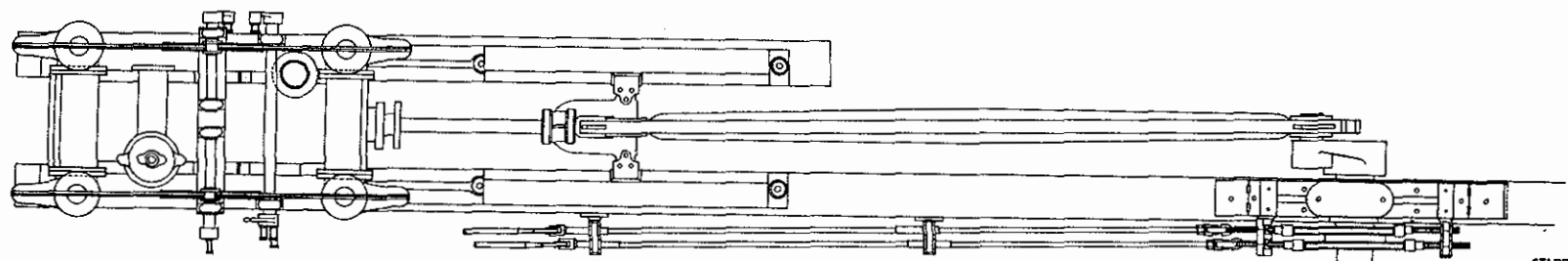

plan

STARBOARD SIDE SHOWN



key

ENGINE, CAM & PITMAN ARM DETAILING

SCALE: 3/4"=1'-0"

BASIC DATA FROM NATIONAL ARCHIVES RECORD GROUP 92

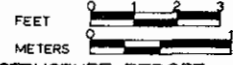

HISTORIC STRUCTURE REPORT

PREPARED	DAFTM	DRAWING NO.	306
DESIGNED	ASHLEY	SHIP NO.	28000
DRAWN	THORSON	SHEET	26
CHECKED		OF 29	
DATE	02/28/81		

ON MICROFILM

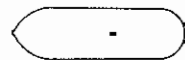
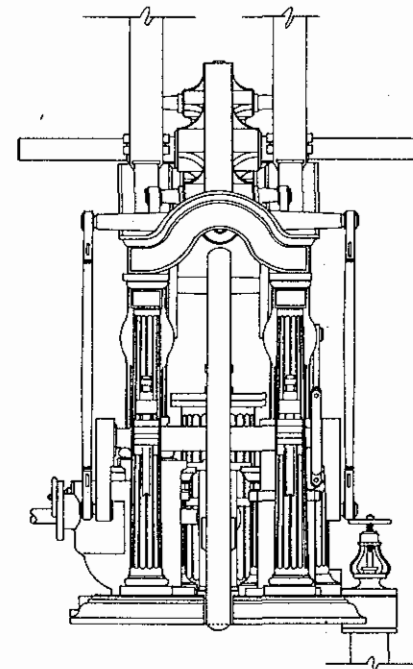
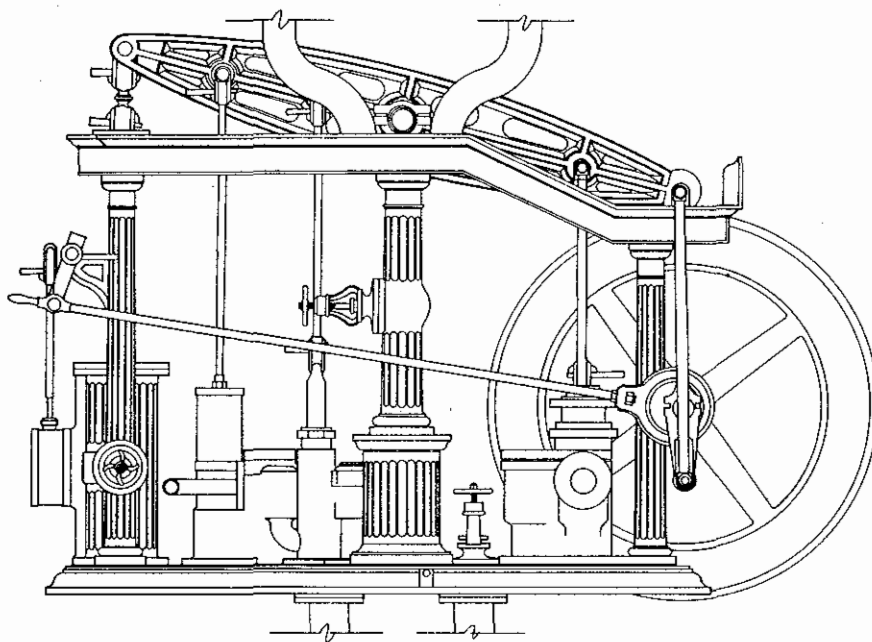

key

MAIN AUXILIARY ENGINE "The Doctor"

SCALE: 1/2" = 1'0"

BASIC DATA FROM NATIONAL ARCHIVES RECORD GROUP 92



HISTORIC STRUCTURE REPORT

PREPARED	ASHLEY	DRAWING NO.	306
DESIGNED	ASHLEY	NO.	28000
DRAWN	ASHLEY	SHEET	27
CHECKED	THORSON	DATE	02/16/81
DATE			of 29

ON MICROFILM

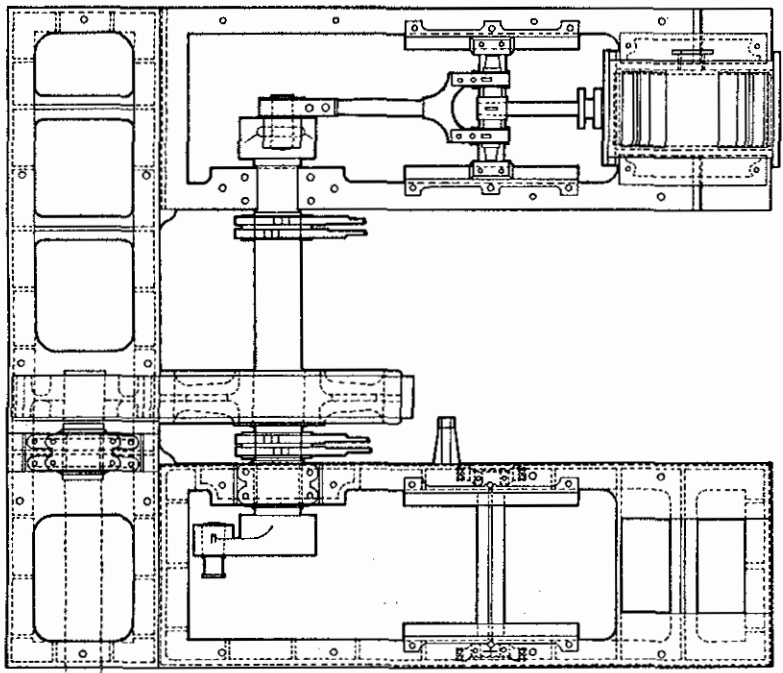
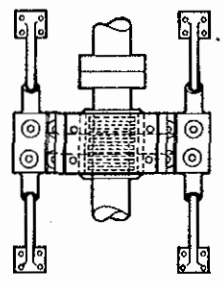
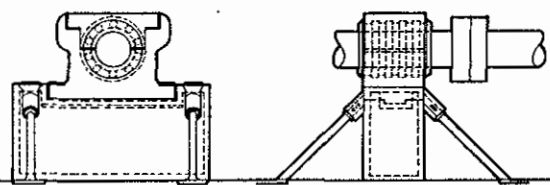
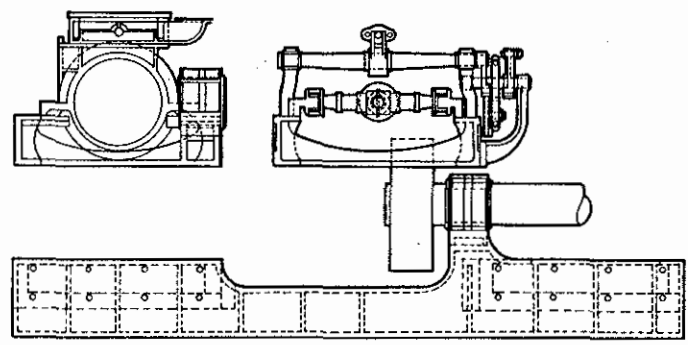
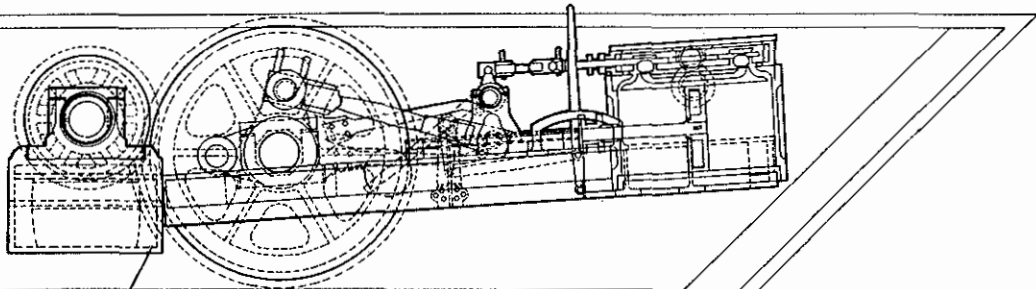

LOCATION UNKNOWN

AUXILIARY ENGINE

BASIC DATA FROM NATIONAL ARCHIVES RECORD GROUP 92

SCALE: 3/4"=1'-0"

HISTORIC STRUCTURE REPORT

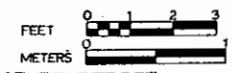

key

PREPARED	ASHLEY	DRAWING NO.	306
REVIEWED	ASHLEY	NO.	28000
DESIGNED	THOMPSON	SHEET	22
CHECKED	BYE	OF	22

ON MICROFILM

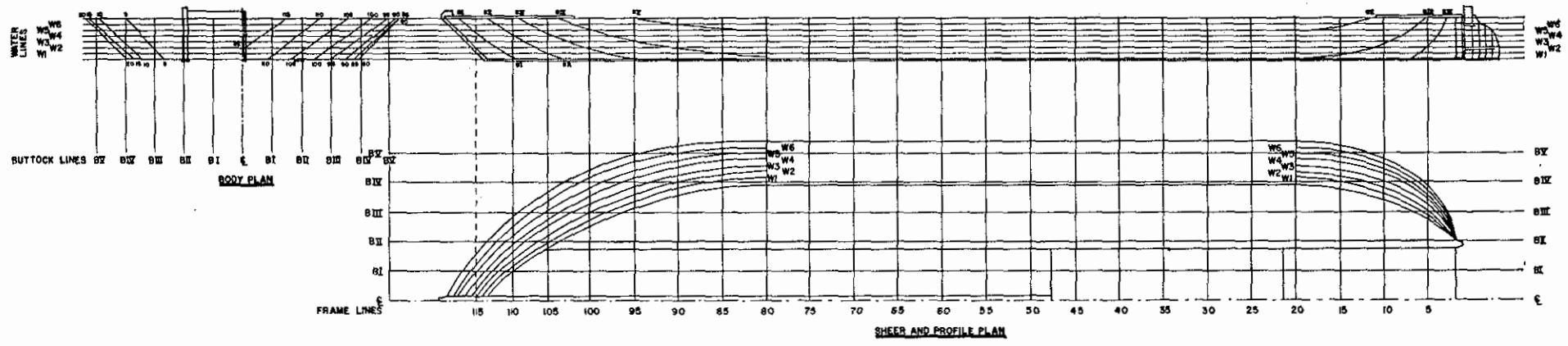

ON MICROFILM

HULL LINES

SCALE: 1/8" = 1'-0"

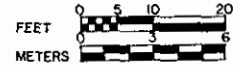

HISTORIC STRUCTURE REPORT

PREPARED MCGRATH	DRAWING NO. 306
DESIGNED MCGRATH	28000
DRAWN THORSON	SHEET 29
CHECKED 02/16/88	OF 22
DATE	

APPENDIXES

- A: "Specifications for Building a Gunboat" - 1861,
Historic City Class Plan
- B: Smithsonian Report on Moisture Content
- C: Cairo Project Chronology
- D: Enabling Legislation
- E: Cairo 106 Compliance Letter
- F: Tabulations of Cairo Cannon Markings

A: "Specifications for Building a Gunboat" - 1861

Note: This is Samuel M. Pooks' original set of specifications. The actual construction of the Cairo varied in some details from the specifications outlined in this historic document. The footnotes are the authors and show where these differences occurred.

The length on deck to be one hundred and seventy-five feet; the extreme breadth to be fifty feet,¹ and the depth of hold to be six feet from the top of the floor timber to the top of the gun-deck beams; to have seven feet clear height between decks under the beams.

The bottom plank to be five inches thick; the floor timber to be ten inches deep; to underside of gun-deck beams five feet;² beams nine inches deep;³ plank four inches; from top of deck to underside of upper deck beams seven feet; beams seven inches, and plank three inches. Total depth fifteen feet two inches.⁴

The frame timbers to be of the best quality white oak, free from sap and all other defects; to be sided four and one-half inches, and to be placed eighteen inches from center to center of frames; to be moulded ten inches at the floor, and

-
1. Actual beam is \pm 52'.
 2. Actual dimension is 5' 2".
 3. Beam is 10" deep.
 4. Actual total depth was 15'5".

diminished to four inches at the top of upper deck;⁵ the floor timbers may be got out nine inches square,⁶ and a scarp made in each end four feet long to receive the futtock at the turn of the bilge; no timbers to have less than three and one-half feet scarp, and each scarp to be bolted with three bolts three-fourths inch in diameter; the double frame to run up to the lower port sill; above this height the timber may be single except the frames which face the ports, where the timbers will be double.

There will be seven ports on each side; three in each end;⁷ the ports to be framed forty-six inches wide, forty-eight inches high, then lined with two-inch plank set back two and one-half inches, to form a rabbet for the port shutters. The shutters to be made two and one-half inches thick, of two thicknesses of one and one-fourth inch oak plank; to be hung below and above with suitable hinges and fixtures for raising, lowering, and securing them.

The outside plank to be four inches thick from the bottom to the port sills; above that height they will be two and one-half inches thick,⁸ planked outside and inside above the port sills; on the flat of the bottom the plank will be five inches thick; the plank to be fastened as follows: on the flat

-
5. Frame timbers were not diminished.
 6. Floor timbers were doubled, sided at $4\frac{1}{2}$ ".
 7. As built, there were four posts on each side, three on forward face of casemate, two on after face.
 8. Plank 4" thick above port sills outside, $2\frac{1}{2}$ " inside.

of the bottom the spikes to be eleven inches long; or five-eighths of one inch bolts may be used; on the sides nine-inch spikes to be the fastenings; and above the port sills the spikes to be five and one-half inches long; the regular fastenings to be two spikes in each timber in each strake; no plank on the sides to be more than nine inches wide, or more than six inches above the port sills.

There will be made in the after end of this vessel an opening to receive the paddle-wheel in the middle. It will be, when finished, eighteen feet wide in the clear, and extend about sixty forward of the stern post, as per plan. It will be framed with an easy curve from the bottom up to the water line, so as to allow the water to pass freely to the water-wheel; the timbers forming this opening will set upon the floor-timbers, and be secured to them by knees⁹, sided four and one-half inches; these timbers will be six inches moulded at the bottom¹⁰, and four inches at the top; they will run up thirty feet in wake of the paddle-wheel above the floor timbers to form the wheel-house, which occupies a space of thirty feet from the fore end of the opening. A tier of stanchions will be placed in the hold fore and aft the boat, on a line¹¹ with the timbers forming the opening for the wheel, to be four and one-half inches square, and placed one on each frame, secured above and below; and the planking in the opening formed for the paddle-wheel, which will be three inches thick, of white

9. No knees were installed.

10. Timbers were not diminished from bottom to top.

11. Stanchions were offset (see as-built plans).

oak, will be continued¹² fore and aft the boat, and spiked to the timbers with two spikes in each timber, thus forming two fore and aft bulkheads the entire length¹³ of the boat--the whole of which will be caulked.

In addition to the two fore and aft bulkheads, there will be four thwartships bulkheads,¹⁴ thus dividing the hold into fifteen water-tight compartments.

There will be three keels in this boat, fourteen inches wide and six and one-half inches¹⁵ thick, and kelsons to correspond--one placed in the center of the boat, and one under each fore and aft bulkhead; they will be bolted through the keelson, floor timber and keel with one bolt in each floor timber, driven on alternate edges of the kelsons and riveted upon rings under the keel.

There will be two bilge strakes on each side of the boat six inches thick and twelve inches wide, to be bolted through the side in the same manner as the keelson, viz: one bolt in each timber, driven through and riveted on rings.

12. Planking was not continuous.

13. Bulkheads do not run entire length of vessel.

14. There were more than four thwartship bulkheads as finally built (see as-built plans).

15. Keels are 6" thick.

The clamps, or shelf pieces, upon which the gun-deck beams rest will be made of two thicknesses of timber,¹⁶ each to be nine inches thick, to fit against the timbers under the beams, to be made square from the beams, and they will taper off to a feather edge two feet below the beams; they will be bolted through the timbers and outside plank with one bolt in each timber, on alternate edges of the clamps, and riveted to rings on the clamps; bolts seven-eighths of an inch in diameter.

There will be one deck hook forward and two breast hooks, sided seven¹⁷ inches, and two deck hooks aft, of the same size,¹⁷ the arm not less than eight feet long, to be bolted through each timber with one bolt in each driven through from the outside and riveted on the hooks; bolts seven-eighths inch diameter.

The boat will then be ceiled with two-inch white oak plank, fastened to the timbers with five inch spikes and caulked. The floors in the wake of the engines will be filled in solid before ceiling is put on.¹⁸ The gun-deck beams will be ten inches square, placed four feet from center to center,¹⁹ and bolted to the shelf pieces with three bolts in each end of each beam; the bolts will be seven-eighths inch diameter and two feet long.

16. Gundeck shelf was 12" thick on outboard piece, 9" on inboard.

17. Actual size 4".

18. Floors are not solid.

19. Gundeck beams alternate in size every other frame from 10" square to 10" x 4" at 2' on center.

A tier of fore and aft pieces, seven inches square, will be framed into and between the beams over the fore and aft bulkheads let into the beams one inch, then a ledge six inches square will be framed into the fore and aft pieces and between every two beams. The gun-deck plank will be of yellow pine, four inches thick, if to be had; if not, white pine, to be four and one-half inches thick,²⁰ will be substituted, spiked to the beams and ledges with spikes nine inches long; to be two spikes in each beam and one in each ledge; the strakes not to exceed eight inches wide.

The waterways of the gun-deck to be of white oak and made in two pieces, each to be ten inches square, the outside piece fitted against the timbers, and the inside piece fitted against it,²¹ the whole to be bolted in each frame, driven through from the outside and riveted upon the inside of the waterway on rings; the bolts seven-eighths inch diameter. There will also be one bolt driven down through the waterway into the end of each beam.

The height of the port sills above the deck will be twenty-four inches, and the spirketing above the waterways will be six inches thick worked two strakes up to the port sills champhered off to three inches at top, and made square with the beams below.

20. White pine was used.

21. The inside piece was not 10" square but was shaped.

The plank above the port sills to be two and one-half inches thick and about six inches wide, put on inside²² and outside, fastened with five and one-half inch spikes. The beams of the upper deck to be seven inches square, to be placed two feet²³ apart from center to center, to fit between the timbers, and cut off outside of the timbers, fastened to the timbers and clamps with two bolts in each end. The upper-deck clamps will be four inches thick and nine inches wide. The upper-deck plank to be of white pine, two and one-half inches thick,²⁴ fastened with six inch spikes and caulked; plank not to exceed seven inches wide.

There will be an opening in this deck eight feet wide fore and aft the boat for ventilation; a coaming will be formed around this opening three inches above the deck and six inches thick; there will also be a center piece of the same height fore and aft the opening, over each beam a thwartship piece will be fitted and fastened to the beam; the whole will then be covered with grating.

There will be awning stanchions fitted on this deck, one in each corner, to be well braced and about six on each side, to be eight feet high; also the same number in the center, to be ten feet high; the stanchions to be five and one-half inches square at the deck and four and one-half at the top; there will be an awning fitted to cover this deck.

22. See note 8.

23. Actual dimension is 3' with the beams located at alternate frames.

24. Actual dimension is 3".

There will be suitable cable bitts²⁵ at each end of the vessel for towing or securing the cables when at anchor, and chocks cased with iron for the cables to lay in when at anchor, and all the necessary fixtures; chain cables to have about five scuppers on each side, to be three by five inches when leaded.

To make a plain cabin with two state rooms,²⁶ two mess rooms, and eight state rooms for officers, fitted with berths and bureau and washstand in each room, to have a table for the cabin and each mess room.

To build a suitable magazine, shell room, and shot locker, as hereafter directed.

To have iron stanchions fitted all around the upper deck with an eye in the top two and one-half feet above the deck to reeve the ridge rope.

To make and fit four pair of iron boats' cranes, fitted to swing and secured by chain guys; to make a wheel-house and fit the steering apparatus in the most approved plan, with wire or chain wheel ropes leading to the upper deck before the smokestacks; to furnish a suitable capstan, to be placed as hereafter directed.

To put in the shackles for breechings and necessary eye bolts for working the bung, etc.

25. Bitt dimensions are 1' 2" x 1' 2".

26. According to diver's drawings made before destruction of the cabins, there was no evidence of a plain cabin with two staterooms (see as-built plans for probable cabin configuration).

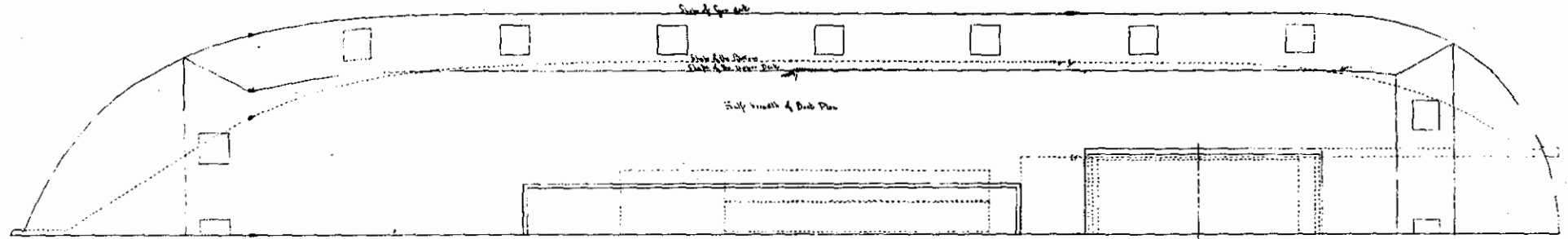

Side & Quarter

Half breadth of Deck Plan

Half breadth of Deck Plan

Transverse Section through the Middle

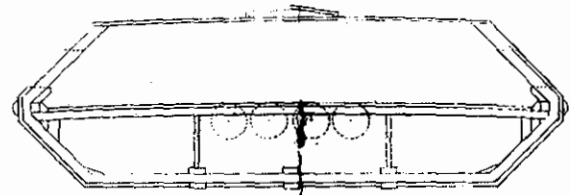

Scale 3/16" to 1 inch

Plan No. 2

Side elevation in Section through the Boat taken lengthwise

Scale horizontal 1/4" for 1 foot

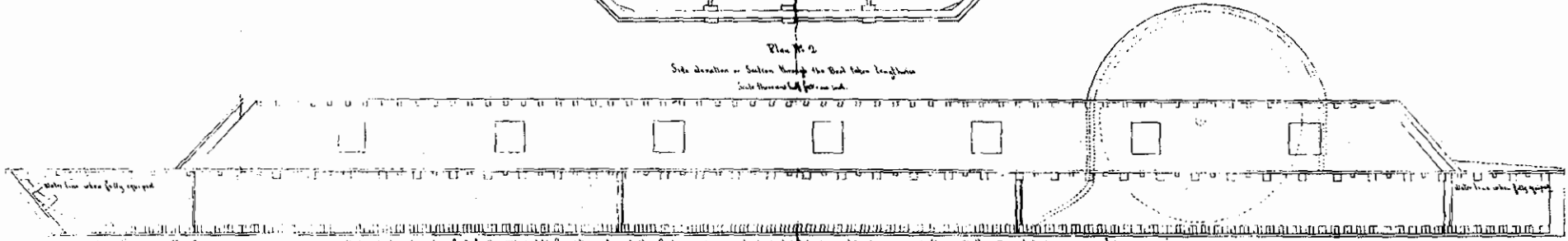

Especially for Riggers
Wm. Rogers
 1817

Vertical Elev. of a Gun Boat for the Mississippi River to be of such the Bunkers and engine to be protected by iron plates, beam against shot or shell. Principal dimensions as follows —
 Length of Boat 100 feet breadth of deck 14 feet 6 inches height of water 4 feet
 Height of water 4 feet
 Draft of water 4 feet
 Gun 18 inch
 Engine 10 horse power
 Bunkers 2 ft high
 to Major General Lee of the United States Army
 Commanding Department of the River.

Wm. Rogers
 P.O.

Mr. J. Cassin—U.S.N. 1817

Traced from original drawing in Patent Office Archives

B: Smithsonian Report on Moisture Content

W.R. Hopwood
R.M. Organ
January 18, 1977

Method

Comparison between Standard Test Method for Moisture Content of Wood, ASTM D 2016 (22) 1976 method A, and the method used here is given below:

	<u>ASTM D 2016</u>	<u>CAL 2740</u>
test specimen	increment core boring, e.g.	increment core boring
linear dimension	1 in preferred	dia. $\frac{1}{4}$ in
volume	2 in ³ preferred	0.05 to 0.2 in ³
precision of balance	± 2 percent	± 0.5 percent
delay in weighing	2 hr	2 days
oven temperature	103 \pm 2 C	101 to 105C
oven type	forced draft preferred	convection

Initial Weighing

The relative humidity in the balance room, as measured with a psychrometer, was found to be 28 percent. The following procedure was carried out for each of the seven specimens in turn: Near the balance, the protective plastics bag and aluminum foil wrappings were removed from the test specimen. The length of the specimen was measured and equal, arbitrary lengths were cut from both ends. The two end pieces were immediately weighed in tarred glass bottles. The closed bottles were kept in a desiccator for 12 days.

Results

The end pieces were then dried to constant weight in pairs. Finally, the average percent moisture, based on the dry weight, of each end piece was calculated.

Summary

By an oven drying method, percent moisture (based on dry weight) was determined for zones cut from the core borings:

<u>Specimen and site from which taken</u>	<u>(depth) Average Percent Moisture</u>	<u>(depth) Average Percent Moisture</u>
Bore #1, 4½", bottom of bow section (right side), planking sample, 2' up from keel, 5' back from bow	(0 - ¾") 82.5%	(3 ¾ - 4½") 103.8%
Bore #2, 2", right side of bow, FRAMING, 4' up from keel, 8' back from bow	(0 - ¾") 45.3%	(1¼ - 2") 92.5%
Bore #3, 6", right side of bow, sample from stem, 3½' up from keel	(0 - 9/16") 33.0%	(4 7/16 - 5") 55.5%
Bore #4, 2½", sample from side planking, same location as from keelson [Keelson] (below water line) - bow	(0 - ¼") 40.3%	(2¼ - 2½") 81.9%
Bore #5, 2½', sample from keel-from bottom up, approx. 12' back from stem-bow	(0 - ¾") 74.8%	(1 ¾ - 2½") 94.4%
Bore #6, 6", from keelson, just forward 2' ± from forward casemate	(0 - ½") 79.6%	(5½ - 6") 90.8%
Bore #7, 10", from engine block (thru block)	(0 - 1") 66.2%	(9 - 10") 82.8%
Ranges -	33.0 to 82.5%	55.5 to 103.8%

C: CAIRO PROJECT CHRONOLOGY

1/15/1862	<u>Cairo</u> commissioned
12/12/1862	<u>Cairo</u> sunk in Yazoo River
11/12/1956	<u>Cairo</u> located by historian Ed Bearss
Winter 1959-60	Operation <u>Cairo</u> , Inc. chartered
9/14/1960	Pilot house raised
3/29/1962	Michael Baker report completed (salvage feasibility)
3/12/1962	Underwater <u>Cairo</u> survey work completed
12/8/1962	Title transferred from federal government to Mississippi Agricultural and Industry Board
4/3/1963	<u>Cairo</u> steering committee named by Mississippi governor
9/6/1963	Dredging around <u>Cairo</u> perimeter begun
9/25/1963	Recovery of artifacts from <u>Cairo</u> begins
12/15/1963	First raising attempt of <u>Cairo</u> begins
7/1/1964	Enabling legislation becomes Mississippi law to allow municipalities and counties to raise funds for <u>Cairo</u> recovery
7/30/1964	<u>Cairo</u> title transferred to Warren County from A&I Board
7/31/1964	Second raising attempt of <u>Cairo</u> begins
12/22/1964	Severely damaged and in numerous pieces, the <u>Cairo</u> wreckage is brought to Pascagoula
1965	Mock up and restoration proposal research at Pascagoula
1968	National Park Service receives \$50,000 allotment for feasibility study of aquisition of the <u>Cairo</u>
March 1971	Companion bills introduced to Congress for <u>Cairo</u> restoraton funding
Fall 1971	House Committee recommends \$4,500,000 for the <u>Cairo</u>

12/4/1971 S1475 passes Senate allotting \$2,481,000 for the Cairo project

8/14/1972 S1475 passes House with a \$4,500,000 appropriation

October 1972 S1472 cost amended by House and Senate to not exceed \$3,200,000

10/12/1972 S1475 signed into law

Summer 1973 Mississippi A&I Board transfers Cairo title to National Park Service

October 1973 Harpers Ferry Center, Denver Service Center, and Vicksburg National Military Park personnel meet to define Cairo restoration/reconstruction guidelines

1973-1976 Cairo display complex construction planning begun by Denver Service Center

9/30/1976 "Preliminary Boat Restoration Study" completed (Barry Howard)

1976 Land Heritage Bill increases Cairo project ceiling to \$4,973,000

1/10/1977 Cairo moving process for Pascagoula to Vicksburg begun

1977 Preliminary "as-built" and existing condition drawings prepared by W.E. Geogehan and J. Smeal

March 1977 Cairo display site construction begins at Vicksburg

6/19/1977 Cairo arrives at Vicksburg NMP

Summer 1977 Contracts awarded for Cairo visitor center, parking facilities, walkways, and utilities

3/14/1978 Vicksburg meeting of National Park Service personnel reaffirms 1973 Cairo reconstruction/restoration goals

11/1/1978 D. Ashley and T. McGrath begin onsite research model and preservation technology phase of the Cairo project

4/9/1979 Research model and preservation technology findings presented to Park Service personnel at Vicksburg; program alternative E selected

10/1980

Shelter structure completed

11/21/1980

Cairo Museum opened

D: Enabling Legislation

4. Vicksburg (including Cairo)

An Act to consolidate Vicksburg National Military Park and to provide for certain adjustments necessitated by the installation of a park tour road, and for other purposes. (77 Stat. 55)

Be it enacted by the Senate and House of Representatives of the United States of America in Congress assembled, That, in order to preserve and protect the essential historical features of Vicksburg National Military Park in the State of Mississippi and to enhance visitor enjoyment and safety by means of a park tour road and through the consolidation of park lands, the Secretary of the Interior is authorized, in his discretion, and under such terms and conditions as he determines are in the public interest—

(a) to quitclaim to the city of Vicksburg, Mississippi, approximately one hundred and fifty-four acres of land, including the roads thereon and the park land abutting said roads, in exchange for the city's agreeing to place the roads in its road system and thereby assume jurisdiction and maintenance thereof, and upon the further agreement of the city to maintain the parklike character of so much of the park land conveyed to it and abutting the road as the Secretary may prescribe, said land being generally that part of Vicksburg National Military Park lying south of Fort Garrott with the exception of Navy Circle, South Fort, and Louisiana Circle: *Provided*, That title to so much of said abutting park land prescribed by the Secretary and covered by said agreement of the city to maintain the parklike character thereof shall revert to the United States if its parklike character is not maintained; to quitclaim to Warren County, Mississippi, upon like terms and conditions approximately twenty-four acres of land, including the road and abutting park land, being known as Sherman Avenue and the Sherman Avenue spur: to release or quitclaim to Warren County or any other appropriate political subdivision of the State all interest which the United States of America has, if any, in those portions of any public road located on park land which are no longer required for park purposes: *Provided*, That the United States shall reserve from the conveyance or conveyances made pursuant to this subsection title to all historical monuments, means of access thereto, and such other easements as the Secretary determines are required for the continued administration of said monuments as a part of Vicksburg National Military Park: and

(b) to acquire not in excess of five hundred and forty-four acres of land, or interests in land, for addition to Vicksburg National Military Park, such

216 IV. NATIONAL MILITARY PARKS—VICKSBURG

authority to include purchase and condemnation with appropriated funds but not to constitute a limitation upon existing authority to accept donations; and

(c) to enter into agreements with duly authorized officials of the city of Vicksburg and Warren County relative to the effect which the installation of a one-way park tour road with controlled access will have upon the existing local road systems; subject to the availability of funds, to obligate the United States to make provision for such alterations, relocations and construction of local roads, including procurement of rights-of-way therefor and the subsequent transfer thereof to the State or its appropriate political subdivisions which shall thereupon assume jurisdiction and maintenance, as the Secretary and said officials agree are directly attributable to the installation of the park tour road; and to transfer to the city or county jurisdiction and maintenance of service roads which the Secretary constructs on park lands to properties that otherwise would be denied access because of the installation of the park tour road.

The Secretary of the Interior shall not, without first obtaining the consent of the city and county officials referred to in subsection (c), convert the portion of the existing road known as Confederate Avenue lying between Graveyard Road and Fort Garrett into a one-way park tour road with controlled access, or otherwise limit the use of such portion by local traffic, until the United States has provided for such alterations, relocations, and construction of local roads (including procurement of rights-of-way) as the Secretary and said officials agree are directly attributable to the installation of such park tour road.

SEC. 2. Upon the delivery and acceptance of the conveyances herein authorized, any jurisdiction heretofore ceded to the United States by the State of Mississippi over the lands and roads transferred shall thereby cease and thereafter rest in the State of Mississippi.

SEC. 3. There are hereby authorized to be appropriated such sums, but not more than \$2,050,000, as are required for acquisition of lands and interests in lands and for construction and relocation of roads pursuant to this Act.

Approved June 4, 1963.

Legislative History

House Report No. 292 accompanying H.R. 1162 (Interior and Insular Affairs Committee).

Senate Report No. 115 (Interior and Insular Affairs Committee).

Congressional Record, Vol. 109, 1963:

Apr. 10: Considered and passed Senate.

May 20: Considered and passed House amended (in lieu of H.R. 1162).

May 21: Senate agrees to House amendment.

IV. NATIONAL MILITARY PARKS—VICKSBURG 217

An Act to authorize the Secretary of the Interior to provide for the restoration, reconstruction, and exhibition of the gunboat "Cairo", and for other purposes. (86 Stat. 796)

Be it enacted by the Senate and House of Representatives of the United States of America in Congress assembled, That in order to preserve an object having national significance as part of the history of the Civil War, for the benefit and inspiration of the people of the United States, the Secretary of the Interior shall, in such manner as he deems advisable, utilize the authorities contained in the Act of August 21, 1935 (49 Stat. 666) to provide for the restoration and reconstruction on the gunboat "Cairo", formerly of the Union Navy, sunk in action in the Yazoo River, Mississippi, and for its exhibition at the Vicksburg National Military Park.

SEC. 2. At such time as the restoration and reconstruction of the "Cairo" shall have been completed, and it has been located within the boundaries of the Vicksburg National Military Park, the "Cairo" shall be administered in accordance with all laws, rules, and regulations applicable to such park.

SEC. 3. There are hereby authorized to be appropriated not more than \$3,200,000 for the restoration of the "Cairo" and for the development of protective and interpretive facilities associated therewith.

Approved October 12, 1972.

Legislative History

House Report No. 92-1220 accompanying H.R. 6618 (Committee on Interior and Insular Affairs).

Senate Report No. 92-533 (Committee on Interior and Insular Affairs).

Congressional Record:

Vol. 117 (1971): Dec. 6, considered and passed Senate.

Vol. 118 (1972):

Aug. 14, considered and passed House, amended, in lieu of H.R. 6618.

Oct. 3, Senate concurred in House amendment with an amendment.

Oct. 4, House concurred in Senate amendment.

E: Cairo 106 Compliance Letter

Advisory
Council On
Historic
Preservation

1522 K Street NW.
Washington D.C. .
20005

October 5, 1979

Mr. Joe Brown
Regional Director
Southeast Region
National Park Service
75 Spring Street, SW
Atlanta, Georgia 30303

Dear Mr. Brown:

On September 27, 1979, the Council received your determination that preservation and restoration of the gunboat Cairo would not adversely affect Vicksburg National Military Park, Warren County, Mississippi, a property included in the National Register of Historic Places. In accordance with Section 800.6(a) of the Council's regulations (36 CFR Part 800), the Executive Director does not object to your determination.

As provided in Section 800.9 of the Council's regulations, a copy of your determination of no adverse effect, along with supporting documentation and this concurrence, should be included in any assessment or statement prepared for this undertaking in compliance with the National Environmental Policy Act and should be kept in your records as evidence of your compliance with Section 106 of the National Historic Preservation Act and the Council's regulations.

Thank you for your cooperation.

Sincerely,

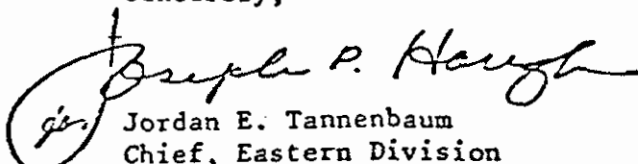
Jordan E. Tannenbaum
Chief, Eastern Division
of Project Review

13 October 1968

8-inch smoothbores of 63 hundredweight (approximately 7,050 pounds)

<u>location upon Cairo</u>	<u>right trunnion</u>	<u>left trunnion</u>	<u>base ring periphery</u>	<u>muzzle swell top filed to form front sight blade</u>
#2 starboard	8 in. 1845	P. G.A.M.	F.P.F. N ^Ω 348 64.0.8	yes
center bow	8 in. 1845	P. G.A.M.	F.P.F. N ^Ω 368 64.0.26	yes
#2 port	8 in. 1845	P. S.B.	W.P.F.A. No. 358. 63.0.18	yes
	*	*	*	*

30-pd Navy PARROTT rifle

<u>location upon Cairo</u>	<u>right trunnion</u>	<u>left trunnion</u>	<u>base ring periphery</u>	<u>right rimbase periphery behind rear sight</u>
aft port	1862	P.	R.P.P. N 61 3460 lbs.	61
	30 p ^{DR} 4.2			
	*	*	*	*

32-pounder smoothbores of 42 hundredweight (approximately 4,600 lbs.)

<u>location upon Cairo</u>	<u>right trunnion</u>	<u>left trunnion</u>	<u>base ring periphery</u>	<u>stop breaching Re chain</u>	<u>muzzle swell top filed to form front sight blade</u>
#3 starboard	32 1845	P. S.B.	W.P.F.A. No. ^o 275 42.2.21	777	yes
stern stbd.	32 1845	P. S.B.	W.P.F.A. No. ^o 280 42.2.7	796	yes
#1 port	32 1845	P. S.B.	W.P.F.A. No. ^o 283 42.1.11		yes
#3 port	32 1845	P. S.B.	W.P.F.A. No. 284 42.2.7	790	yes
#4 starboard	32 1845	P. A.S.W.	F.P.F. N ^Ω 226 42.2.20		yes
#4 port	32 1845	P. A.S.W.	F.P.P. N ^Ω 230 42.1.18		yes

Army 42-pounders, rifled

<u>location upon Cairo</u>	<u>right trunnion</u>	<u>right rimbase</u>	<u>left trunnion</u>	<u>breech over knob</u>	<u>base under knob</u>	<u>muzzle top</u>	<u>face bottom</u>	<u>tube over trunnions</u>	<u>muzzle swell top filed to form front sight blade</u>
port bow	K. & W. F.P.F.	312	1,856	8,359		N ^Ω 8	B.H.	U.S.	yes
starboard bow	K. & W. F.P.F.	324	1,856	8,397		N ^Ω 20	B.H.	U.S.	yes
#1 starboard	J.M. C.F.		1,837		8,620	N ^Ω 26		U.S.	yes

GLOSSARY OF TERMS

Arm	The spoke of the paddle wheel
Balance bucket	A heavy bucket plank in the paddle wheel used to balance the weight of the crank and pitman
Beams	The substantial pieces of timber that stretch across the ship from side to side to support the decks and keep the ship to her breadth
Berth	A bed or the place a ship is docked
Bilge	That part of the bottom of a vessel that is next to the keel
Bilge turn	The rounded part of the hull where the side meets the bottom
Bitts	Forecastle bitts are perpendicular timbers stepped in the keel and extending above the deck; used for securing towing-hawers, etc.
Bow	The front of the hull
Brasses	Bearings; the steel journal, or axle, run in brass bearings.
Breast hooks	The knees placed across the stem and apron for the purpose of uniting the bows
Breeching	The rope passing around the cascabel of a gun and employed to prevent the recoil beyond a certain limit--the ends of the breeching have eyes and are secured by pins (called breeching bolts) in the ship's side
Bulkhead	A partition or wall
Capstan	An upright winch used for pulling lines
Carline	A joist carrying any deck bove the main deck
Casemate	The inclined sides of the enclosure on a warship from which guns are fired through gun ports
Casing	The sheet metal enclosure around the boiler and its insulating firebrick
Ceiling	The lining or inside planking of a vessel
Chock	A deck fitting used for leading lines; a roller chock is fitted with a sheave to reduce friction

Davit	Crane used for lifting and lowering small boats, pronounced "davey"
Draft	The amount of the hull extending into the water, measured vertically
Fantail	The deck outboard of the cylinder timbers and aft of the hull
Fire box	The room where the fireman stands
Flange	The hub on the paddle wheel where the arms were attached
Forward	Toward the forepart of the vessel
Frames (also timbers or ribs)	The bends of timber which form the body of the ship, each of which is composed of one floor timber, two or three futtocks, and a top timber on each side, which, being united together, form the frame; of these frames, or bends, that which encloses the greatest space is called the midship or main frame or bend
Futtocks	The separate pieces of timber of which the frame timbers are composed
Grating	Lattice-work platforms used to cover hatches, yet provide ventilation and light
Hatch	An opening through a deck is a hatch
Heat shield	A sheet metal plate hung forward of the breeching to protect the firemen from the heat
Hog	The amount that a boat has sagged at the ends and risen amidship
Hog chain	A wrought iron rod used to hold up the ends of the hull
Hogging	The tendency for a hull to hump up in the center and droop at the ends
Hold	The inside of the hull
Hull	The portion of a vessel that does the floating and carries the rest.
Hurricane deck	The lowest roof deck
Inboard	Toward the center of the boat

Iron circle	The steel or iron parts just inside the bucket planks of a paddle wheel
Keelson	Longitudinal timber resting on the floors in the hull; pronounced "kelson"
Knees	The crooked pieces of oak timber by which the ends of the beams are secured to the sides of the ship; of these such as are fixed vertically to the sides are called hanging-knees, and such as are fixed parallel to, or with the hang of, the deck, are called lodging-knees
Knuckle	A sudden angle made on some timbers by a quick reverse of shape
Lines of a vessel	Drawings which show the lines of a vessel comprise three separate plans, depending one upon the other, and which must correspond in all particulars and be used in conjunction; these three plans are known as the shear plan, body plan, and half-breadth section
Mud drum	A drum located under the boilers to collect sediment and support the boilers
Pilothouse	The place where the pilot works; it is not called a bridge, but may occasionally have bridges out to the sides for the convenience of the pilot in looking over the sides of the boat
Pillow block	The supporting members of a shaft bearing
Pitman	The connecting rod between the engine crosshead and the paddle wheel crank
Pitman steps	Steel or wrought iron straps bolted to top and bottom of the pitman
Port	The left-hand side of the vessel looking forward; at one time called larboard
Quarter	That part of the vessel's side near the stern
Roller chock	A chock with a roller in it to reduce rope friction
Rudder	A movable underwater blade used to steer the vessel
Rudder irons	The name applied collectively to the pintles and gudgeons

Scantling	Any board used in framing; when steel replaced wood, the steel members were called by the same names as wooden ones and hull members are called scantlings to this day.
Scarphing	The letting of one piece of timber or plank into another with a lap, in such a manner that both may appear as one solid and even surface, as keel-pieces, stem pieces, clamps, yards, masts, etc.
Scupper	A deck drain pronounced "dreen"
Shaft	The axle of the paddle wheel
Sheer	The graceful swooping curve of the deck, when seen from the side
Stanchion	Vertical framing post supporting a deck
Starboard	The right hand side of a vessel when looking forward
Stem	The perpendicular piece of timber at the extreme forward part of the ship which is scarphed into the keel
Strake	One breadth of plank wrought from one end of the ship to the other, either within or without board
Trunnions	The projections on each side of a cannon which rest upon the gun-carriage and support the piece

BIBLIOGRAPHY

MANUSCRIPT MATERIALS

Denver. National Park Service, Denver Service Center, Cairo Research Team. Field notes (1972-1979) including:

Daily Logs, Project Development

Field Notes (Three Volumes)

Metal Preservation

Manufacturers' Product Data

Photograph Albums:

Condition in Pascagoula

Gunboat Bow, Front Casemate, Pilothouse (Historic)

Gunboat Engines, Paddle Wheel, Catamarans

Ingalls Shipyard Condition

Ingalls Shipyard Operation and Reassembly, 1976

Miscellaneous Artifacts

Slide Albums:

Comparative Data

Existing Conditions

Model Constructions (Two Volumes)

Technical Material, Preservation Material

Wood Preservation Data

Washington, D.C. National Archives. Record Group 92, Records of the Office of the Quartermaster General. Samuel M. Pook, "Specifications for Building a Gunboat."

_____, _____. Official Records of the Union and Confederate Armies, War of the Rebellion. Series III, Vol. II, pp. 816-832. Thomas Merritt, "Specifications for Engines on the Gun-Boats, No. 2."

OTHER WORKS

Bates, Alan. The Western Rivers Steamboat Cyclopoedium or American Riverboat Structure and Detail, Salted with Lore and a Nod to the Modelmaker. Leonia, N.J.: Hustle Press, 1968.

Baxter, James Phinney III. Introduction of the Ironclad Warship. Cambridge University Press, 1933.

Bearss, Edwin C. Hardluck Ironclad, The Sinking and Salvage of the Cairo. 2nd ed. Baton Rouge: Louisiana State University Press, 1980.

Brodie, Bernard. Seapower in the Machine Age. Princeton University Press, 1941.

Brodie, Bernard, and Brodie, Fawn M. From Crossbow to H-Bomb. Bloomington: Indiana University Press, 1973.

Chapelle, Howard I. "Fulton's 'Steam Battery' Blockship and Catamaran." United States National Museum Bulletin of History and Technology 39(1964):137-176.

Hamilton, Donny Leon. Conservation of Metal Objects from Underwater Sites: A Study in Methods. Miscellaneous Papers, no. 4. Texas Memorial Museum, 1976.

Barry Howard and Associates. "U.S.S. Cairo, Planning and Research." Prepared for the National Park Service, Denver Service Center, 1976.

_____. "Boat Restoration Study." Prepared for the National Park Service Denver Service Center, 1976.

Kihlber, Bengt, ed. The Lore of Ships. Crescent Books, 1975.

Marine Engines, Marine Pumps. International Textbook Company, 1906.

Miller, Francis Trevelyan, ed. The Photographic History of the Civil War. Vol. 6.: The Navies. A. S. Barnes and Company, 1906.

National Trust for Historic Preservation. The Monitor, Its Meaning and Future, Papers from a National Conference. Washington, D.C.: The Preservation Press, 1978.

Nautical Word Book. Bogota, N.J: Model Shipways, 1961.

Sawyer, William D. "The Western River Engine." Steamboat Bill 146 (Summer 1978).

The Third International Congress of Maritime Museums. Schedule and Papers. Mystic Seaport, 1978.

United States Department of the Interior, National Park Service. "The Steamboat Bertram, History, Excavation, and Architecture," by James Persche. 1974.

Wilson, H.W. Ironclads in Action, A Sketch of Naval Warfare from 1855 to 1895. Vol. 1. Sampson, Low, Marston, and Company, 1896.

As the nation's principal conservation agency, the Department of the Interior has basic responsibilities to protect and conserve our land and water, energy and minerals, fish and wildlife, parks and recreation areas, and to ensure the wise use of all these resources. The department also has major responsibility for American Indian reservation communities and for people who live in island territories under U.S. administration.

Publication services were provided by the graphics staff of the Denver Service Center.