



Emerging Technologies *for Biosolids Management*



Emerging Technologies

for

Biosolids Management



**Office of Wastewater Management
U.S. Environmental Protection Agency
Washington, D.C.**



Emerging Technologies for Biosolids Management

EPA 832-R-06-005

September 2006

Produced under U.S. EPA Contract No. 68-C-02-111

Prepared by the Parsons Corporation

Fairfax, Virginia

Technical review was provided by professionals with experience in biosolids management. Technical reviewers of this document were:

Michelle Hetherington and Michael Moore, *Orange County Sanitation District, Fountain Valley, California*

Robert Pepperman, *Environmental Group Services, White Marsh, Maryland*

Timothy G. Shea, *CH2M Hill, Herndon, Virginia*

Lori Stone, *National Biosolids Partnership, Alexandria, Virginia*

Robert Reimers, *Tulane University, New Orleans, Louisiana*

Paul Rom, *Black & Veatch, Chicago, Illinois*

Recycled/Recyclable

Printed with vegetable-based ink on paper that contains a minimum of 50 percent post-consumer fiber content chlorine free.

Electronic copies of this handbook can be downloaded from the

U.S. EPA Office of Wastewater Management web site at:

www.epa.gov/owm

Preface

The U.S. Environmental Protection Agency (U.S. EPA) is charged by Congress with protecting the nation's land, air, and water resources. Under a mandate of environmental laws, the Agency strives to formulate and implement actions leading to a balance between human activities and the ability of natural systems to support and sustain life. To meet this mandate, the Office of Wastewater Management (OWM) provides information and technical support to solve environmental problems today and to build a knowledge base necessary to protect public health and the environment well into the future.

This publication has been produced under contract to the U.S. EPA by Parsons Corporation and provides information on the current state of development as of the publication date. It is expected that this document will be revised periodically to reflect advances in this rapidly evolving area. Except as noted, information, interviews and data development were conducted by the contractor. It should be noted that neither Parsons nor U.S. EPA has conducted engineering or operations evaluations of the technologies included. Some of the information, especially related to embryonic technologies, was provided by the manufacturer or vendor of the equipment or technology and could not be verified or supported by full-scale case study. In some cases, cost data were based on estimated savings without actual field data. When evaluating technologies, estimated costs, and stated performance, efforts should be made to obtain current information.

The mention of trade names, specific vendors, or products does not represent an actual or presumed endorsement, preference, or acceptance by the U.S. EPA or the Federal government. Stated results, conclusions, usage, or practices do not necessarily represent the views or policies of the U.S. EPA.

Contents

	Page
Executive Summary	ES-1
1. Introduction and Approach.....	1-1
1.1 Introduction	1-1
1.2 Approach.....	1-2
1.2.1 Information Collection and New Process Identification	1-3
1.2.2 Initial Screening Technologies.....	1-4
1.2.3 Development of Technology Summary Sheets	1-11
1.2.4 Evaluation of Technologies	1-11
1.3 Guidance Document Format and Use	1-13
1.4 Chapter References	1-14
2. Conditioning.....	2-1
2.1 Introduction	2-1
2.2 Technology Assessment.....	2-1
3. Thickening.....	3-1
3.1 Introduction	3-1
3.2 Technology Assessment.....	3-1
4. Stabilization.....	4-1
4.1 Introduction	4-1
4.2 Technology Assessment.....	4-1
5. Dewatering.....	5-1
5.1 Introduction	5-1
5.2 Technology Assessment.....	5-1
6. Thermal Conversion.....	6-1
6.1 Introduction	6-1
6.2 Technology Assessment.....	6-1

Contents

	Page
7. Drying.....	7-1
7.1 Introduction	7-1
7.2 Technology Assessment.....	7-1
8. Other Processes.....	8-1
8.1 Introduction	8-1
8.2 Technology Assessment.....	8-1
9. Research Needs	9-1
9.1 Introduction	9-1
9.2 Research Needs	9-1
9.2.1 Analysis and Reduction of Risk Associated with Certain Beneficial Use Practices	9-2
9.2.2 Utilization of the Potential of Biosolids to Yield Energy	9-2
9.2.3 Improved Operation, Performance and Efficiency of Biosolids Treatment Processes	9-3
9.2.4 Research Needs	9-3
9.2.5 Chapter References.....	9-3
Appendix A	A-1
A.1 Introduction	A-1
A.2 Trade Associations.....	A-1

List of Tables

	Page
Table 1.1 Summary of Biosolids Technologies	1-6
Table 1.2 Descriptive Evaluation Criteria.....	1-12
Table 2.1 Conditioning Technologies – State of Development	2-1
Table 3.1 Thickening Technologies – State of Development	3-1
Table 4.1 Stabilization Technologies – State of Development.....	4-1
Table 5.1 Dewatering Technologies – State of Development	5-2
Table 6.1 Thermal Conversion Technologies – State of Development.....	6-2
Table 7.1 Drying Technologies – State of Development.....	7-1
Table 8.1 Other Processes – State of Development.....	8-1
Table 9.1 Research Needs Technologies: State of Development.....	9-2

List of Figures

	Page
Figure 1.1 Summary of Wastewater Solids Management in the U.S.	1-2
Figure 1.2 Flow Schematic for Guide Development.....	1-3
Figure 2.1 Evaluation of Innovative Conditioning Technologies.....	2-2
Figure 3.1 Evaluation of Innovative Thickening Technologies	3-2
Figure 4.1 Evaluation of Innovative Stabilization Technologies	4-2
Figure 5.1 Evaluation of Innovative Dewatering Technologies.....	5-2
Figure 6.1 Evaluation of Innovative Thermal Conversion Technologies	6-2
Figure 7.1 Evaluation of Innovative Drying Technologies	7-2
Figure 8.1 Evaluation of Other Innovative Processes.....	8-2

List of Abbreviations

ABR	anaerobic baffled reactor
AGF	anoxic gas flotation
ATAD	autothermal thermophilic aerobic digestion
ASCE	American Society of Civil Engineers
AWWA	American Water Works Association
BOD	biochemical oxygen demand
BTU	British thermal unit
CBFT3	Columbia biosolids flow-through thermophilic treatment
CFR	Code of Federal Regulations
CIP	capital improvement program
COD	chemical oxygen demand
cP	centipoise
CWMP	comprehensive wastewater management plan
DAFT	dissolved air flotation thickening
DC	direct current
DCWASA	District of Columbia Water and Sewer Authority
EPRI	Electric Power Research Institute
ERS	energy recovery system
FELL	Focused Electrode Leak Locator
g/ac/day	gallon per acre per day
gpcd	gallon per capita per day
gpd	gallon per day
GTI	Gas Technology Institute
HAPs	hazardous air pollutants
HIMET	high methane process
IEUA	Inland Empire Utilities Agency
JWPCP	Joint Water Pollution Control Plant
kg	kilogram
kWh	kilowatt-hour
MFP	master facilities plan

List of Abbreviations

MGD	million gallons per day
MLSS	mixed liquor suspended solids
MSO	molten salt oxidation
NOAA	National Oceanic and Atmospheric Administration
NPDES	National Pollutant Discharge Elimination System
OCS	oxygen combustion system
O&M	operation and maintenance
OWM	Office of Wastewater Management
POTW	publicly owned treatment works
PSI	pound per square inch
RHOX	reheat and oxidize process
RP	recycling plant
SRF	State Revolving Fund
SRT	solids retention time
SSDML	sewage sludge digestion and metal leaching
SW	southwest
SWSSD	Southwest Suburban Sewer District
TPAnD	temperature-phased anaerobic digestion
tpd	ton per day
U.S.	United States
U.S. EPA	U.S. Environmental Protection Agency
USDA	U.S. Department of Agriculture
VAR	vector attraction reduction
VS	volatile solids
VSR	volatile solids reduction
WEF	Water Environment Federation
WERF	Water Environment Research Foundation
WWTF	wastewater treatment facility
WWTP	wastewater treatment plant

Executive Summary

Biosolids (sewage sludge) are the nutrient-rich organic materials resulting from treatment and processing of wastewater residuals. U.S. Environmental Protection Agency (U.S. EPA) estimates that the publicly owned wastewater treatment works (POTW) generate over 8 million tons (dry weight) of sewage sludge annually. Figure 1.1 summarizes how this material is managed. The technologies in this document help reduce the volume of residuals, and produce biosolids that can be used, help improve soil fertility and tilth, while decreasing the use of inorganic fertilizers, and promote the conservation of energy.

This document provides information regarding emerging biosolids management technologies organized into three categories based on their stage of development:

Embryonic – Technologies in the development stage and/or tested at laboratory or bench scale. New technologies that have reached the demonstration stage overseas, but cannot yet be considered to be established there, are also considered to be embryonic with respect to North American applications.

Innovative – Technologies meeting one of the following qualifications: (1) have been tested at a full-scale demonstration site in this country; (2) have been available and implemented in the United States (U.S.) for less than 5 years; (3) have some degree of initial use (i.e. implemented in less than twenty-five utilities in the U.S.; and (4) are established technologies overseas with some degree of initial use in the U.S.

Established – Technologies widely used (i.e. generally more than 25 facilities throughout the U.S.) are considered well established.

The document also provides information on each technology—its objective, its description, its state of development, available cost information, associated contact names, and related data sources. For each innovative technology, this document further evaluates with respect to various criteria, although it does not rank or recommend any one technology over another. Research needs are also identified to help guide development of innovative and embryonic technologies and improve established ones.

References

U.S. EPA. Office of Solid Waste. Biosolids Generation, Use, and Disposal in the United States. EPA 530-R-99-009 (1999).

Introduction and Approach

1.1 Introduction

Wastewater treatment processes produce residuals, also called sewage sludge, as a by-product of the treatment processes. Biosolids are the nutrient-rich organic materials resulting from the treatment and processing of these residuals. U.S. EPA estimates that the publicly-owned wastewater treatment works generate over 8 million tons (dry weight) of sewage sludge annually. Figure 1.1 summarizes how this material is managed. The technologies in this document help reduce the volume of residuals, produce biosolids that can be used, help improve soil fertility and tilth, while decreasing the use of inorganic fertilizers, and promote the recovery of energy.

To meet the challenge of keeping progress in wastewater pollution abatement ahead of population growth, changes in industrial processes, and technological developments, U.S. EPA is providing this document to make information available on recent advances and emerging techniques. The goal of this document is straightforward—to provide a guide for persons seeking information on innovative and embryonic biosolids treatment technologies. The guide lists processing technologies, where available assesses their merits and costs, and provides sources for further technological information. This document is intended to serve as a tool for wastewater facility owners and operators. It should be noted that neither Parsons nor U.S. EPA has conducted engineering or operations evaluations of the technologies included. The information provided is from the vendors and/or practitioners; no detailed verification of vendors' claims has been undertaken.

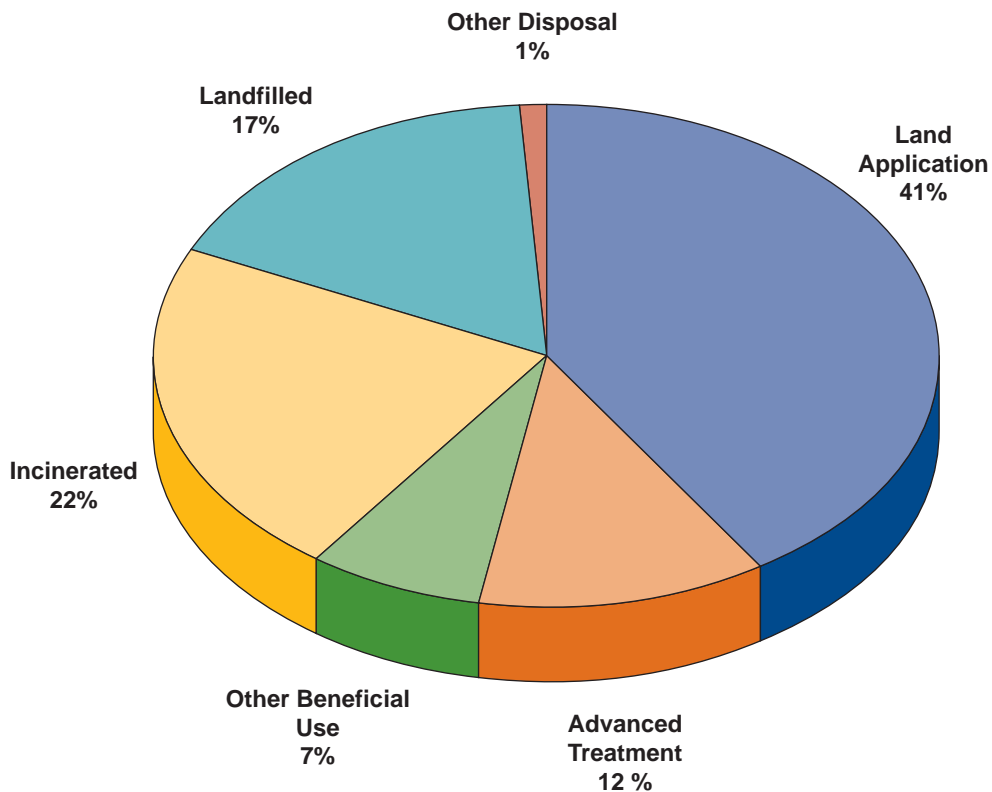

Figure 1.1 – Summary of Wastewater Solids Management in the U.S.
(Source: U.S. EPA 1999)

Emerging technologies typically follow a development process that leads from laboratory and bench-scale investigations to pilot studies and, subsequently, to initial use or “full-scale demonstrations” before the technology is considered established. Not all technologies survive the entire development process. Some fail in the laboratory or at pilot stages; others see limited application in the field, but poor performance, complications, or unexpected costs may cause them to lose favor. Even technologies that become established may lose favor in time, as technological advances lead to obsolescence. In short, technologies are subject to the same evolutionary forces present in nature; those that cannot meet the demands of their environment fail, while those that adapt to changing technological, economic, and regulatory climates can achieve long-standing success and survival in the market.

1.2 Approach

To develop this guide, the investigators sought information from a variety of sources, identified new technologies, prepared cost summaries, and evaluated technologies deemed to be innovative.

This method is described below and in Figure 1.2.

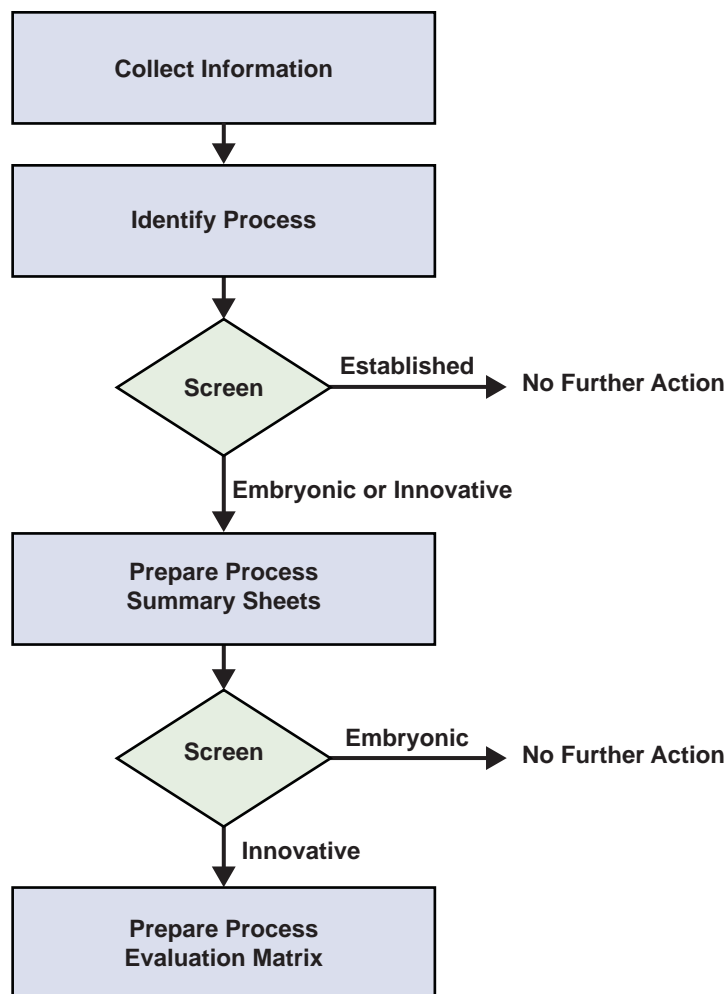

Figure 1.2 Flow Schematic for Guide Development

1.2.1 Information Collection and New Process Identification

Information collection on new technologies provided the foundation for subsequent work. To identify new biosolids processing technologies, investigators gathered information from a variety of sources, including the following:

Published Literature – An extensive literature review was performed to identify new technologies, and to evaluate their performance and applications. Specifically, the review focused on relevant Water Environment Federation (WEF) and American Society of Civil Engineers (ASCE) conference proceedings, as well as other publications from these and other organizations.

“Gray” Literature – Vendor-supplied information, Internet research, and consultants’ technical reports were the primary sources of gray literature.

Technical Associations – Investigators contacted a variety of professional and technical associations in the United States, including members of WEF, to identify emerging wastewater treatment technologies.

Interviews and Correspondence – Individuals known to the project investigation team, including consultants, academics, and municipal wastewater treatment plant owners and operators, were consulted.

Technologies identified through searches of the above sources were screened to determine their classification as described below.

1.2.2 Initial Screening Technologies

This project focuses on emerging technologies that appear to be viable, but have not yet been accepted as established processes in the United States. Specific screening criteria used to define the state of development for processes are described in the following paragraphs. This screening resulted in:

25 Embryonic Technologies

31 Innovative Technologies

Embryonic – These technologies are in the development stage and/or have been tested at laboratory or bench scale. New technologies that have reached the demonstration stage overseas, but cannot yet be considered to be established there, are also considered to be embryonic with respect to North American applications.

Innovative – Technologies that meet one of the following criteria were classified as innovative:

- They have been tested as a full-scale demonstration;
- They have been available and implemented in the United States for less than five years;
- They have some degree of initial use (i.e. implemented in less than 25 municipalities throughout the United States); or,
- They are established technologies from overseas.

Established – In most cases, these processes are used at more than 25 full-scale facilities in North America; but there are some exceptions based upon specific considerations. The established category may include technologies that are widely used although introduced more recently in North America. In some cases, an established technology such as Anaerobic Digestion may have been modified or adapted resulting in a new, innovative technology such as Thermally Phased Anaerobic Digestion. Due to the extensive number of established technologies and variations in each technology, established technologies are only listed. None are described in depth in this document and Technology Summary sheets are not provided for established technologies.

The focus of this document is on Innovative Technologies along with some coverage of Embryonic Technologies as well. Early in the development process (laboratory stage), data are usually insufficient to prove or disprove technology viability at full scale; available information on these embryonic technologies is presented in this document. Technologies on the other end of the developmental scale, those defined as established in North America, are excluded from the detailed assessments on the assumption that they are proven, although still relatively new.

The differentiation between technologies established in Europe or Asia and those that have reached similar status in the United States can be critical since technologies that have been applied successfully in other countries have not always flourished here. Because the viability of imported technologies is not guaranteed, established processes from overseas are classified as innovative technologies for this project unless they have been proven in North American applications.

Some technologies fall into a “gray area” between the embryonic and innovative categories. Technologies that fall into this category are incorporated into the innovative category. The screening assessment is summarized in Table 1.1.

Table 1.1 – Summary of Biosolids Technologies

Technology and Advancement(s)	Potential Benefit* as Compared to Established Technologies					
	Low Capital Cost	Low Annual Costs	Reduces Solids or Thickens	Produces Class A Biosolids	Reduces Odor	Beneficial Use (Non Agriculture)
Chapter 2 Conditioning						
Established						
Chemical Conditioning						
Heat Conditioning						
Innovative						
Cell Destruction						
Chemical (Microsludge™)		●	●			
Ultrasonic		●	●			
Embryonic						
Cell Destruction Biological (BODIET®)		●	●			
Electrocoagulation			●			
Enzyme Conditioning			●			
Chapter 3 Thickening						
Established						
Centrifuge						
Flotation Thickening						
Gravity Belt Thickening						
Gravity Thickening						
Rotary Drum Thickening						
Innovative						
Flotation Thickening – Anoxic Gas	●	●	●		●	
Membrane Thickening	●	●	●			
Recuperative Thickening	●	●	●			
Embryonic						
Metal Screen Thickening	●		●			

Table 1.1 – Summary of Biosolids Technologies (Contd)

Technology and Advancement(s)	Potential Benefit* as Compared to Established Technologies					
	Low Capital Cost	Low Annual Costs	Reduces Solids or Thickens	Produces Class A Biosolids	Reduces Odor	Beneficial Use (Non Agriculture)
Chapter 4 Stabilization						
Established						
Aerobic Digestion						
Autothermal Thermophilic Aerobic Digestion (ATAD)						
Alkaline Stabilization						
Advanced Alkaline Stabilization						
Anaerobic Digestion						
Dual Digestion						
Two-Stage Mesophilic						
Composting						
Pasteurization						
Solidification						
Synox						
Innovative						
Aerobic Digestion						
Aerobic/Anoxic	●	●	●			
Anaerobic Digestion						
Anaerobic Baffled Reactor (ABR)	●	●	●			
Columbia Biosolids Flow-Through – Thermophilic Treatment (CBFT3)	●	●	●	●		
High Rate Plug Flow (Bio Terminator 24/85)	●	●	●			
Temperature Phased Anaerobic Digestion (TPAND)	●	●	●	●		
Thermal Hydrolysis (CAMBI Process)	●	●	●	●		
Thermophilic Fermentation (ThermoTech™)	●	●	●	●		
Three-Phase Anaerobic Digestion			●	●		
Two-Phase-Acid/Gas Anaerobic Digestion	●	●	●	●		
Vermicomposting	●	●		●		
Embryonic						
Aerobic Digestion						
Simultaneous Digestion and Metal Leaching			●			

Table 1.1 – Summary of Biosolids Technologies (Contd)

Technology and Advancement(s)	Potential Benefit* as Compared to Established Technologies					
	Low Capital Cost	Low Annual Costs	Reduces Solids or Thickens	Produces Class A Biosolids	Reduces Odor	Beneficial Use (Non Agriculture)
Anaerobic Digestion						
Ozone Treatment				●		
Ferrate Addition				●	●	
Disinfection						
Irradiation				●	●	
Neutralizer®				●	●	
Chapter 5 Dewatering						
Established						
Belt Filter Press						
Centrifuge						
Chamber Press						
Drying Beds						
Auger-Assisted						
Natural Freeze-Thaw						
Vacuum-Assisted						
Vacuum Filters						
Innovative						
Drying Beds						
Quick Dry Filter Beds	●	●	●			
Electrodewatering	●	●	●			
Metal Screen Filtration						
Inclined Screw Press	●	●	●			
Textile Media Filtration						
Bucher Hydraulic Press	●	●	●			
DAB™ System	●	●	●			
Geotube® Container	●	●	●			
Embryonic						
Electro Dewatering						
Electroacoustic	●	●	●			
Electroosmotic	●	●	●			

Table 1.1 – Summary of Biosolids Technologies (Contd)

Technology and Advancement(s)	Potential Benefit* as Compared to Established Technologies					
	Low Capital Cost	Low Annual Costs	Reduces Solids or Thickens	Produces Class A Biosolids	Reduces Odor	Beneficial Use (Non Agriculture)
Membrane Filtration	●	●	●			
Membrane Filter Press						
Textile Media Filtration						
Simon Moos	●	●	●			
Tubular Filter Press	●	●	●			
Thermal Conditioning and Dewatering						
Mechanical Freeze-Thaw			●			
Chapter 6 Thermal Conversion						
Established						
Combustion						
Fluidized-Bed Furnace						
Multiple-Hearth Furnace						
Oxidation						
Wet Air Oxidation						
Innovative						
Combustion						
Reheat and Oxidize (RHOX)						
Oxidation						
Supercritical Water Oxidation						
Vitrification						
Minergy						
Embryonic						
Combustion						
Molten Salt Incineration						
Oxygen Enhanced Incineration						
Fuel Production						
Gasification						
Sludge-to-Oil						
SlurryCarb™						

Table 1.1 – Summary of Biosolids Technologies (Contd)

Technology and Advancement(s)	Potential Benefit* as Compared to Established Technologies					
	Low Capital Cost	Low Annual Costs	Reduces Solids or Thickens	Produces Class A Biosolids	Reduces Odor	Beneficial Use (Non Agriculture)
Oxidation						
Deep-Shaft Wet Air Oxidation (VERTAD™)		●	●	●		
Plasma Assisted Sludge Oxidation	●		●			
Vitrification						
Melting Furnace			●			●
Chapter 7 Drying						
Established						
Direct Drying						
Flash Drying						
Indirect Drying						
Innovative						
Belt Drying	●		●	●		●
Direct Microwave Drying	●		●	●		●
Flash Drying	●		●	●		●
Fluidized Bed Drying	●		●	●		●
Embryonic						
Chemical Drying	●		●	●	●	●
Multiple Effect Drying						
Carver-Greenfield (Not a viable technology)						
Chapter 8 Other Processes						
Innovative						
Cannibal Process	●	●	●			
Lystek	●	●		●		
Injection into Cement Kiln	●	●	●		●	●

* Potential Benefits require confirmation on a case-by-case basis. May enhance existing facilities, replace existing facilities, or offer an alternative choice for new facilities. For existing facilities, analysis of invested costs to date must be considered.

1.2.3 Development of Technology Summary Sheets

Technologies defined as embryonic or innovative are summarized on an individual Technology Summary sheet. Each process includes the following information:

Objective – Description of the goal of the technology.

State of Development – Where and how the technology has been applied (i.e. laboratory study, demonstration scale, full scale, etc.).

Description – A brief overview of the technology.

Comparison to Established Technologies – A brief comparison to established technologies that serve the same function in biosolids management.

Available Cost Information – An approximate range of capital and operation and maintenance (O&M) (on an annual basis) costs, and assumptions made in developing them. Annual O&M costs typically include labor, equipment replacement and/or parts, energy, and chemicals. For many of the technologies, sufficient information was not available for detail annual costs so general values are presented.

Contact Names – Names, addresses, and telephone numbers of contacts (vendors and practitioners) with additional information on the technology.

Key Words for Internet Search – Words used to enhance Internet searches for more information.

Data Sources – References used to compile the technology summary.

1.2.4 Evaluation of Innovative Technologies

Technologies defined as innovative in the initial screening were subjected to a detailed evaluation presented in tabular format. Each technology was evaluated with respect to the descriptive and comparative criteria described below. Descriptive criteria include:

State of Development – Describes the stage of development for each technology, ranging from demonstration stage to full-scale operations.

Applicability – Qualitatively assesses where the technology is designed to be used.

Beneficial Use – Describes the potential for the technology to produce a biosolids product suitable for beneficial use (e.g. agriculture, construction, or power generation).

Potential Benefits – Considers the benefits gained (e.g., capital or operational savings, reduces odor, produces Class A biosolids, etc.) from implementation of the technology.

Designations for each descriptive criterion are presented in Table 1.2.

Table 1.2 Descriptive Evaluation Criteria

Criterion	Designation	Description
State of Development	B	Bench scale
	P	Pilot scale
	I	Full-scale industrial applications, with demonstration or pilots for municipal sewage sludge
	O	Full-scale operations overseas
	D	Full-scale demonstration in North America
	N	Full-scale operations in North America
Applicability	I	Industrywide
	F	Few plants
	S	Primarily small plants
	L	Primarily large plants
Beneficial Use	A	Agriculture
	C	Construction
	P	Power
Potential Benefits	C	Low or lower capital costs
	O	Low or lower annual costs
	V	Reduces solids or produces thicker product Concentrations
	A	Produces Class A biosolids
	M	Reduces odors
	F	Produces high nutrient fertilizer
	R	Beneficial use (nonagricultural)

Comparative criteria are general attributes that the technology may possess relative to attributes of established technologies in the same category (e.g., conditioning etc.), for the same criteria. The innovative technologies may be rated positive, neutral or negative compared to expectations for established technologies. These criteria include:

Impact on Other Processes – Describes the degree to which the existing facilities will be disturbed.

Complexity – Considers the construction method and operation of the technology.

Air Emission – Considers the potential for air emissions including odor.

Beneficial Use – Considers the potential to produce a product that allows for more beneficial use options.

Energy – Considers the potential to directly produce power or to produce a product that has characteristics that make it suitable for energy generation.

Footprint – Considers the requirement for land to support the construction of the technology at full-scale.

Environmental – Considers other factors associated with the technology that may produce environmental impacts or enhance environmental conditions.

The criteria and ratings were applied to each innovative technology and the results are presented in matrix format. Where available information was insufficient to rate a technology for a criterion, no rating is given. The project team and reviewers assessed each technology based on the limited information gathered and their collective judgment, experience, and opinions. Results of the evaluation are presented in subsequent chapters.

1.3 Guidance Document Format and Use

The majority of the document is divided into chapters based upon general technologies. One chapter is dedicated to each of the following categories:

Conditioning (Chapter 2)

Thickening (Chapter 3)

Stabilization (Chapter 4)

Dewatering (Chapter 5)

Thermal Conversion (Chapter 6)

Drying (Chapter 7)

Other Processes (Chapter 8)

Each chapter overviews the technology included, discusses the state of development for each, presents an evaluation matrix for innovative and embryonic technologies, and concludes with a Technology Summary sheet for each innovative and embryonic technology.

The technology summaries and evaluation matrices are the cornerstones of each chapter, giving a broad overview of the innovative technologies. Neither the summaries nor the matrices should be considered definitive technology assessments. Rather, they should be considered stepping stones to more detailed investigations.

The final chapter, Chapter 9, discusses research needs related to biosolids management.

This document should be updated from time to time. Technologies were reviewed in mid-2006.

1.4 Chapter References

U.S. EPA. Office of Solid Waste. *Biosolids Generation, Use, and Disposal in the United States*. EPA 530-R-99-009 (1999).

U.S. EPA. Office of Water. *Clean Watersheds Needs Survey 2000 Report to Congress*. EPA 832-R-03-001 (2003)

Conditioning

2.1 Introduction

Conditioning processes enhance biosolids characteristics for subsequent processing. This chapter focuses on the latest developments in conditioning technologies.

2.2 Technology Assessment

Table 2.1 summarizes the state of development of conditioning technologies.

Recent technology innovations in the area of conditioning now include electro-coagulation, ultrasonic disintegration, and enzyme addition as well as a combination of conditioning processes. These processes aim at modifying the organic and inorganic characteristics of biosolids critical to other following processes. Conditioning is typically linked to other processes and the purpose of conditioning is based upon the goals of these other subsequent processes. Often the results achieved by conditioning are seen in the subsequent processes rather than the conditioning process itself.

Figure 2.1 includes an evaluation of the emerging technologies identified in this report. Summary sheets for each innovative and embryonic technology are provided at the end of this chapter.

Table 2.1 – Conditioning Technologies—State of Development

Established	Innovative	Embryonic
Chemical Conditioning Heat Conditioning	Cell Destruction <ul style="list-style-type: none"> ▪ Chemical (MicroSludge™) ▪ Ultrasonic 	Cell Destruction <ul style="list-style-type: none"> ▪ Biological (BIODIET®) Electrocoagulation Enzyme Conditioning

Figure 2.1 – Evaluation of Innovative Conditioning Technologies

Process	Evaluation Criteria										Comments
	Development	Applicability	Potential Benefits	Beneficial Use	Impact on Other Processes	Complexity	Air Emissions	Energy	Footprint	Environmental	
Chemical Cell Destruction (MicroSludge™)	D	I	V,O	N/A	⊖	▼	⊖	▼	▲	⊖	
Ultrasonic Cell Destruction	O	I	V,O	N/A	⊖	▼	⊖	▼	▲	⊖	

<p>Statement of Development</p> <p>B = Bench scale D = Full-scale demonstrations in North America I = Full-scale industrial applications, with demonstrations or pilots for municipal sewage sludge O = Full-scale operations overseas N = Full-scale operations in North America P = Pilot</p>	<p>Applicability</p> <p>F = Few plants I = Industrywide L = Primarily large plants S = Primarily small plants</p>	<p>Potential Benefits</p> <p>A = Produces Class A biosolids C = Capital savings O = Operational/maintenance savings F = Produces high-nutrient fertilizer M = Minimizes odors R = Provides beneficial use (nonagricultural) V = Sludge volume reduction</p>	<p>Beneficial Use</p> <p>A = Agriculture C = Construction N/A = Not Applicable P = Power</p>
<p>Comparative Criteria</p> <p>▲ Positive feature ⊖ Neutral or mixed ▼ Negative feature</p>			

Technology Summary

Chemical Cell Destruction (MicroSludge™)

Objective:

Destroy the cell membranes of microbes in waste activated sludge to increase the performance of anaerobic digestion. Increase the amount of biogas generated from anaerobic digestion of biosolids.

State of Development: Innovative

The first full-scale MicroSludge™ chemical biocell destruction demonstration was conducted at the Chilliwack Wastewater Treatment Plant (WWTP) near Vancouver, Canada in 2004. A second full-scale demonstration started at the Los Angeles County Sanitation Districts Joint Water Pollution Control Plant in October 2005. Neither is currently operating.

Description:

Waste-activated sludge from the secondary clarifier enters a central unit where caustic chemicals (NaOH) are added. The mixture is held for one hour to weaken cell membranes and significantly lower viscosity. As described by the developer of MicroSludge™, the technology employs an industrial-scale high-pressure homogenizer or “cell disrupter” to provide an enormous and sudden pressure drop to lyse the bacterial cells in the sludge. The processed sludge is liquefied, mixed with primary sludge, and anaerobically digested to produce stabilized biosolids and biogas.

The central unit of the process is a high-pressure cell disrupter that subjects waste-activated sludge to a large abrupt pressure drop. The sludge in the cell disruption valve is accelerated up to 300 meters per second (1,000 feet per second) in approximately 2 microseconds. The sludge then impinges on an impact ring, disrupting the cell membranes, and liquefying the waste-activated sludge.

Comparison to Established Technologies:

Similar to conventional chemical conditioning only in that chemicals are added to the solids with the goal of breaking cellular bonds. The caustic additive is not similar to chemicals traditionally used such as ferrous or aluminum salts.

Available Cost Information:

Approximate Capital Cost: \$1.7 million to \$2 million

Approximate O&M Costs: \$68 to \$119 per dry ton of activated sludge

The above range, provided by the vendor, is for a MicroSludge™ System 50 capable of processing approximately 50,000 U.S. gallons of thickened waste-activated sludge per day. According to the vendor, larger systems would cost proportionately less per dry ton to operate. These costs do not include installation costs.

The operating cost estimate, again provided by the MicroSludge™ vendor, includes electricity, chemicals, and maintenance. The above O&M cost estimate is for processing activated sludge to a range of 4 – 7% total solids. The estimate assumes electricity is purchased at \$0.07/kilowatt-hour and chemicals costs are \$0.21/pound. Electricity is the largest single operating cost contributor. Power consumption between 500 – 1,000 kWh/ton dry solids is required for this process.

Vendor Name(s):

Paradigm Environmental Technologies, Inc.
200, 1600 West 6th Avenue
Vancouver, BC
Canada V6J 1R3
Phone: 604-742-0360
Website: www.paradigmenvironmental.com

Practitioner(s):

The following were sites of technology demonstration but are not current practitioners:
Chilliwack Wastewater Treatment Plant
8550 Young Road
Chilliwack, British Columbia V2P 8A4
Joint Water Pollution Control Plant, Los Angeles County
Sanitation Districts
Carson, CA

Technology Summary

Chemical Cell Destruction (MicroSludge™) (Contd)

Key Words for Internet Search:

MicroSludge™, anaerobic digestion, cell lysis, chemical pretreatment, volatile solids reduction, sludge, biosolids

Data Sources:

Rabinowitz, B. and R. Stephenson "Full-Scale Demonstration of Waste-Activated Sludge Homogenization at the Los Angeles County Joint Water Pollution Control Plant." Proceedings of the WEF/AWWA Joint Residuals and Biosolids Management Conference, Cincinnati, Ohio, (12 – 15 March 2006).

Paradigm Environmental Technologies, Inc. (2006). Personal e-mail communication with Director of Marketing, Filipe Figueira, on 12 May 2006.

Technology Summary

Ultrasonic Cell Destruction

Objective:

Increase the rate at which anaerobic digestion of solids occurs; improve sludge settling; facilitate denitrification, promote recovery of biogas for energy production.

State of Development: Innovative

The full-scale technology has been used at the Bad Bramstedt Sewage Works, Germany, in Kävlinge, Sweden (2002) and at Mangere Wastewater Treatment Plant, New Zealand (2005).

Description:

Acoustic waves are applied to solids prior to digestion to attain extremely high pressures and temperatures within the biosolids. This results in the implosion of gas bubbles, which produces shear stresses that break up surfaces of bacteria, fungi, and other cellular matter. Different disintegration objectives can be achieved using either high- or low-frequency waves. The vendor claims that the process has been shown to increase cell disruption, reduce anaerobic digestion time, reduce sludge quantity and raise biogas production. Typically, this process is applied to waste activated solids, not primary solids.

Comparison to Established Technologies:

Ultrasonic disintegration is meant to enhance traditional anaerobic digestion by increasing the rate of floc and cell disintegration. Since hydrolysis can be a rate-limiting factor in anaerobic digestion, the claim is that ultrasonic disintegration increases the digestion rate, volatile suspended solids concentration, and gas production.

Available Cost Information:

Approximate Capital Cost: \$265,000

Approximate O&M Costs: \$10,000 – \$20,000 per year

Capital cost is based on a 5 – 8 million gallon per day facility treating 30% of the sludge produced per day. Operation and maintenance costs derived from a test plant in Riverside, southern California. Operation and maintenance cost assumptions include supervision, parts, and power. Current energy prices will significantly impact power-related expenses.

Vendor Name(s):

EIMCO® Water Technologies
2850 S. Decker Lake Drive
Salt Lake City, UT 84119
Phone: 801-526-2342
Fax : 801-526-2910
E-mail: info@eimcowater.com

Practitioner(s):

The following was the site of a demonstration system but is not a current practitioner:
Orange County Sanitation District
P.O. Box 8127
Fountain Valley, CA 92728-8127

Sonico LLC (North America)
3020 Old Ranch Parkway, Suite 180
Seal Beach, CA 90740
Phone: 562-314-4231

Technology Summary

Ultrasonic Cell Destruction (Contd)

Key Words for Internet Search:

Ultrasonic cavitation, ultrasonic disintegration, Sonolyzer, biosolids, sludge

Data Sources:

Vendor-supplied information

Technology Summary

Biological Cell Destruction (BIODIET®)

Objective:

Promote biological disintegration of organic matter in organic sludges to water and carbon dioxide, thereby reducing sludge volume.

State of Development: Embryonic

This technology is primarily marketed in Japan for highly organic industrial (i.e. food processing) sludges. Currently marketed as BIODIET®.

Description:

Activated sludge is diverted from the settling tank to a vessel where a chemical agent is added. The agent has strong oxidizing power, causing the cell walls of the bacteria to become weak and breakdown. The processed bacteria are then returned to the activated sludge unit where they decompose into carbon dioxide and water. The BIODIET® process is intended for organic sludges only; volume reduction will be impacted by the amount of inorganic material in the sludge.

Comparison to Established Technologies:

Not similar to any established technologies.

Available Cost Information:

Approximate Capital Cost: Not available

Approximate O&M Costs: Detailed information is not available but the vendor's website presents anecdotal information showing a cost savings of over 50% using BIODIET® compared to conventional methods of managing industrial waste.

Vendor Name(s):

Plant Engineering Division
Kankyo Engineering Company, Ltd.
1-9-8 Higashikanda, Chiyoda-ku
Tokyo 101-0031 Japan
Phone: 81-3-3862-1611
Fax : 81-3-3862-1617
E-mail: general@k-eng.co.jp

Practitioner(s):

No practitioner at this time.

Key Words for Internet Search:

BIODIET®, Japanese wastewater treatment, sludge

Data Sources:

Japanese Advanced Environment Equipment. BIODIET®. Global Environment Centre Environmental Technology Database NETT21. (2002).

T. Hagino, S. Gohda, H. Yoshida. "A Sludge-Thickening-Dehydrating System Featuring Single Polymer Conditioning" The Abstract of Ebara Engineering Review. (1999).

Vendor-supplied information.

Technology Summary

Electrocoagulation

Objective:

Increase the rate at which anaerobic digestion of solids occurs; improve sludge settling; facilitate denitrification, promote recovery of biogas for energy production.

State of Development: Embryonic

Electrocoagulation has been used for mining and metals industry applications since the 1900s. The wastewater treatment plant at the Vancouver Shipyards (British Columbia) has been using electrocoagulation for 4 years to successfully remove heavy metals and emulsified oils. The system does not, however, remove antifreeze or solvents, nor can it treat soluble biochemical oxygen demand (BOD) and other organic constituents of sewage.

Powell Water Systems, Inc. markets electrocoagulation technology for domestic wastewater treatment and claims anywhere from 85 to 99.99% removal of several wastewater constituents, including heavy metals, phosphates, fats and oils, insoluble BOD, and Total Coliforms.

Description:

Electrocoagulation uses an electrical current to dissolve a sacrificial anode and thereby introduce chemically reactive aluminum into the wastewater stream. These positively charged aluminum ions are attracted to the very fine negatively charged ions and particles in suspension. The resulting agglomerations of particulates increase in size until they no longer remain in suspension. Simultaneously, gases formed by hydrolysis form very fine bubbles that associate with the particulates and buoy them up to the surface of the treated wastewater for removal by flotation.

Comparison to Established Technologies:

Not similar to any established technologies

Available Cost Information:

Approximate Capital Cost: \$451,000 (500 gpd system) \$1,520,000 (3,000,000 gpd system)

Approximate O&M Costs: \$678 per day (500 gpd system) \$2,791 per day (3,000,000 gpd system)

Capital cost estimates are for the Powell electrocoagulation unit only, and they do not take into account additional construction costs that may be necessary to install the unit. Operation and maintenance costs include electricity, labor, replacement blades, and maintenance.

Vendor Name(s):

Powell Water Systems, Inc.
19331 Tufts Circle
Centennial, CO 80015-5820
Phone: 303-627-0320
Fax : 303-627-0116
E-mail: scottpowell@powellwater.com
Website: www.powellwater.com

Practitioner(s):

Vancouver Shipyards Co. Ltd.
North Vancouver, B.C.
Canada V7P 2R2
Phone: 602-988-6361
Fax: 604-990-3290
Email: info@vanship.com

Technology Summary

Electrocoagulation (Contd)**Key Words for Internet Search:**

Electrocoagulation, conditioning, dewatering, biosolids, sludge.

Data Sources:

Stephenson, R., B. Tennant, D. Hartle, G. Geatros. "Vancouver shipyards treat emulsified oily wastewater using electrocoagulation." Watermark Newsletter of the British Columbia Water & Waste Association. (2003).

Vendor-supplied information.

Technology Summary

Enzyme Conditioning

Objective:

Degrade organic material to increase the dewaterability of biosolids and, in some cases, to reduce odors and aid in digestion processes.

State of Development: Embryonic

Enzymes have shown promising results in breaking down fats and oils in meat industry pretreatment facilities, as well as in reducing odors, solvents, and chemical oxygen demand (COD) in aeration tanks, lagoons, and biosolids digesters. There has also been research with promising results showing significant increase in percent solids from conventional dewatering of enzyme-treated solids.

Description:

Mixtures of enzymes, specialized nutrients (i.e. humic acids, amino acids) and often aerobic and anaerobic bacteria cultures are added to thickening and digestion systems that produce enzymes specially engineered to degrade organic materials converting them into carbon dioxide and water. Reported advantages include limited damage to biological treatment systems and cost savings as the enzymatic reaction will continue to occur over several days.

Comparison to Established Technologies:

Enzyme destruction of cells is not similar to any established processes.

Available Cost Information:

Approximate Capital Cost: \$31 per pound of enzyme solution

Approximate O&M Costs: Not available

The manufacturer of Enviro-Zyme® recommends various amounts of solution depending on the amount of sludge to be treated. For example, 1 pound is needed to treat 1 to 5 tons of sludge, 2 pounds are required for 6 to 25 tons of sludge, and so on.

Vendor Name(s):

Eco-Cure, Inc.
1525 Casa Buena Drive Suite D
Corte Madera, CA 94925
Phone: 415-924-8450
Email: jimkritchever@yahoo.com
Website: www.eco-cure.com

Envoguard
298 Kings Mill Rd York, PA 17403
Phone: (800) 297-8266
Email: info@envoguard.com
Website: www.envoguard.com

Enviro-Zyme® International, Inc.
P.O. Box 169
Stormville, NY 12582
Phone: 800-882-9904
E-mail: info@envirozyme.com

Practitioner(s):

See websites for practitioners:
www.eco-cure.com/enzymeinfodert.htm

Technology Summary

Enzyme Conditioning (Contd)

Vendor Name(s) (Contd):

Vendor Name(s):

The Moorhead Group, Inc

108 Don Lorenzo Court

Aptos, CA 95003

Phone 831-685-1148

Fax 831-685-1259

info@moorheadgroup.com

www.moorheadgroup.com

NRP, Inc.

2948 N. W. 60th Street

Fort Lauderdale, FL 33309

Phone: 954-970-7773

Fax: 954-970-7778

hschure@nrp-inc.com

www.nrp-inc.com

Suez

www.suez.com

Western Bio-Tec Services

1265 W. 16th Street

Long Beach, CA 90813-1381

Phone: 949-456-0058

[Email: westernbiotec@aol.com](mailto:westernbiotec@aol.com)

[Website: www.westernbiotec.com](http://www.westernbiotec.com)

Key Words for Internet Search:

Enviro-Zyme, enzyme conditioning, odorants, ACE, Agricycle Catalyst Enzyme, WESBAC, Biolysis-e.

Data Sources:

Vendor-supplied information.

Dursun, D., A Ayol, S.K. Dentel. "Pretreatment of Biosolids by Multi-Enzyme Mixtures Leads to Dramatic Improvements in Dewaterability." Proceedings of the WEF Residuals and Biosolids Management Conference 2006: Bridging to the Future, Cincinnati, OH (12-14 March 2006).

Toffey, William E., Matthew Higgins. "Results of Trials and Chemicals, Enzymes and Biological Agents for Reducing Odorant Intensity of Biosolids." Proceedings of the WEF Residuals and Biosolids Management Conference 2006: Bridging to the Future, Cincinnati, OH (12-14 March 2006).

Thickening

3.1 Introduction

The goal of thickening is to increase the concentration of solids. Thickening enhances treatment processes that follow such as stabilization, dewatering, and drying. This chapter focuses on the latest developments in thickening technologies.

3.2 Technology Assessment

Table 3.1 summarizes the state of development of thickening technologies.

Recent technology developments in this area focus on various methods to increase solids concentrations such as anoxic gas flotation, membrane thickeners and recuperative thickeners. These technologies can help reduce chemicals and increase the efficiency of subsequent processes such as digestion. Some odor reduction during thickening also has been recognized.

Figure 3.1 includes an evaluation of the innovative technologies identified in this report. Summary sheets for each innovative and embryonic technology are provided at the end of this chapter.

Table 3.1 – Thickening Technologies—State of Development

Established	Innovative	Embryonic
Centrifuge Flotation Thickening Gravity-Belt Thickening Gravity Thickening Rotary Drum Thickening	Flotation Thickening <ul style="list-style-type: none"> ▪ Anoxic Gas Membrane Thickening Recuperative Thickening	Metal Screen Thickening

Figure 3.1 – Evaluation of Innovative Thickening Technologies

Process	Evaluation Criteria										Comments
	Development	Applicability	Potential Benefits	Beneficial Use	Impact on Other Processes	Complexity	Air Emissions	Energy	Footprint	Environmental	
Flotation Thickening – Anoxic Gas	P	I	C,O,V,M	N/A	▲	⊖	⊖	⊖	▲	⊖	
Membrane Thickening	N	I	C,O,V	N/A	▲	▲	⊖	⊖	▲	⊖	
Recuperative Thickening	P	I	C,O,V	N/A	▲	⊖	⊖	⊖	▲	⊖	

<p>Statement of Development</p> <p>B = Bench scale D = Full-scale demonstrations in North America I = Full-scale industrial applications, with demonstrations or pilots for municipal sewage sludge O = Full-scale operations overseas N = Full-scale operations in North America P = Pilot</p>	<p>Applicability</p> <p>F = Few plants I = Industrywide L = Primarily large plants S = Primarily small plants</p>	<p>Potential Benefits</p> <p>A = Produces Class A biosolids C = Capital savings O = Operational/maintenance savings F = Produces high-nutrient fertilizer M = Minimizes odors R = Provides beneficial use (nonagricultural) V = Sludge volume reduction</p>	<p>Beneficial Use</p> <p>A = Agriculture C = Construction N/A = Not Applicable P = Power</p>
<p>Comparative Criteria</p> <p>▲ Positive feature ⊖ Neutral or mixed ▼ Negative feature</p>			

Technology Summary

Flotation Thickening – Anoxic Gas

Objective:

Thicken contents of an anaerobic digester to reduce volume of solids to dewater and transport. Increase digester capacity.

State of Development: Innovative

The technology was used for over a year at the Salmon Creek Plant in Burien, King County, Washington. Volatile solids were increased from approximately 50% to 71%; resulting in a 34% reduction in volume of solids to be hauled off site. In addition, odors from the belt presses and the amount of polymer required for dewatering were both reduced. Plant operations, which used to experience frequent foaming incidents, improved; there were no foaming incidents while the technology was employed. The process is also used to treat dairy and potato processing wastes in the U.S.

Description:

This totally-enclosed process involves separating and thickening solids removed from anaerobic digestion using digester gas to float solids which are removed and returned to the digester. The technology is typically employed as an enhancement to existing conventional digesters. Solids are concentrated to 6 – 10%. All gases are discharged back to the anaerobic digester or to a biofilter.

Comparison to Established Technologies:

Similar to Dissolved Air Flotation Thickening (DAFT), however, uses digester gas instead of air.

Available Cost Information:

Approximate Capital Cost: \$7.50 per dry lb (at 6-8% solids, or \$1.90 per gallon) processed per day

Approximate O&M Costs: \$8.00 per dry ton of biosolids processed for polymer

Capital costs include associated equipment (saturator, controls, polymer feed, inlet/outlet pumps) and will vary with the surface loading rate to the separators. The quoted costs are based on processing 200 pounds of dry solids per square foot per day. According to the vendor, each gallon processed per day through an AGF will reduce feed through digester by 1.5 to 2.0 gallons per day.

Operational costs include a polymer requirement of 4 pounds per dry ton of biosolids processed at \$2.00 per pound. However, total polymer use may decrease.

Cost information supplied by vendor.

Vendor Name(s):

Environmental Energy Engineering Company
6007 Hill Road NE
Olympia, WA 98516
Phone: 360-923-2000
E-mail: dennis@makingenergy.com
www.makingenergy.com

Practitioner(s):

The following hosted a demonstration project but is not a current practitioner:
Southwest Suburban Sewer District (SWSSD)
Salmon Creek Wastewater Treatment Plant
431 Ambaum Blvd. SW
Burien, WA 98166
Phone: 206-244-2202
Fax: 206-433-8546
E-mail: millercreekWWTP@aol.com

Technology Summary

Flotation Thickening – Anoxic Gas (Contd)

Key Words for Internet Search:

Anoxic gas flotation, AGF, biosolids, Salmon Creek WWTP, King County Washington

Data Sources:

King County Applied Wastewater Program. "AGF – Anoxic Gas Flotation." Demonstration project evaluation. (2000).

Burke, D.A. "Application of AGF (Anoxic Gas Flotation) Process." Environmental Energy Company. (2000) Vendor-supplied information

Burke, D.A "Producing Exceptional Quality Biosolids through Digestion, Pasteurization, and Redigestion". Biosolids 2001: Building Public Support Conference Proceedings Water Environment Federation/AWWA/CWEA Joint Residuals and Biosolids Management Conference. (2001).

Technology Summary

Membrane Thickening

Objective:

Thickening of waste-activated sludge.

State of Development: Innovative

Membrane thickeners are operating in several locations throughout the U.S. Full-scale facilities are in use in Dundee, Michigan and Fulton County, Georgia among other locations.

Description:

A basin with suspended biomass and a membrane system that provides a barrier for the solid-liquid separation. These membranes can be used in an aerobic environment to achieve separation of liquid from biomass. Anaerobic environments have plugged membranes too quickly in tests. Therefore, aerobic environments are needed for oxygen mixing. Thickening to over 4% solids has been reported. Flux through the membrane is reduced to half the value for membranes used in activated sludge basins. The different types of membranes are described as modular and they are of the following types: tubular, hollow-fiber, spiral wound, plate and frame, and pleated cartridge filters.

Comparison to Established Technologies:

Similar to MBRs for wastewater treatment. Membranes for thickening require a smaller footprint than many established thickening technologies.

Available Cost Information:

Approximate Capital Cost: \$125,000 for a one-train system with two cassettes.

Approximate O&M Costs: Not provided by vendor.

Vendor Name(s):

Enviroquip, Inc.
2404 Rutland Drive, Suite 200
Austin, TX
Phone: 512-834-6019
[Website: www.enviroquip.com](http://www.enviroquip.com)

Infilco Degremont - U.S. Headquarters
P.O. Box 71390
Richmond, VA 23255-1390
8007 Discovery Drive
Richmond, VA 23229-8605 USA
Phone: (804) 756-7600
[Website: www.infilcodegremont.com/membrane_filtration.html](http://www.infilcodegremont.com/membrane_filtration.html)

Mitsubishi International Corporation
333 South Hope Street West, Suite 2500
Los Angeles, CA 90071
Phone: 213-687-2853
[Website: www.micusa.com](http://www.micusa.com)

Practitioner(s):

Village of Dundee Wastewater Treatment Plant
596 E Main St
Dundee, MI 48131-1208
Phone: 734-529-3001

Fulton County Public Works Department
Cauley Creek Water Reclamation Facility
141 Pryor Street, Suite 6001
Atlanta, GA 30303
Phone: 404-730-7442
www.co.fulton.ga.us/public_works_projects/index_new_pubwks1.html
See www.zenon.com/resources/case_studies/wastewater/ for additional practitioners.

Technology Summary

Membrane Thickening (Contd)

US Filter/MEMCOR

4116 Sorrento Valley Blvd.

San Diego, CA 92121

Contacts for regional offices that provide information on MEMCOR are available at

[www.usfilter.com/en/Product+Lines/Memcor Products/Contacts/memcor_us_contacts.htm](http://www.usfilter.com/en/Product+Lines/Memcor+Products/Contacts/memcor_us_contacts.htm)

Veolia Water Solutions & Technologies

L'Aquarène

1 place Montgolfier

94417, Saint Maurice

France

Phone: +33 (0)1 45 11 55 55

Website: www.veoliawater.com

Zenon Environmental Services, Inc.

3239 Dundas Street West

Oakville, Ontario

Phone: 905-465-3030

Fax: 905-465-3050

Website: www.zenon.com



Typical membrane unit

Key Words for Internet Search:

Membrane thickening, biosolids membrane treatment, sludge separation

Data Sources:

Metcalf and Eddy. Wastewater Engineering Treatment and Reuse. 4th Edition. (2003).

Vendor-supplied information.



*Overview of the Cauley Creek WRF
Fulton County, GA*



*MBR Technology at Cauley Creek WRF
Fulton County, GA*

Technology Summary

Recuperative Thickening

Objective:

Reduce biosolids volume, enhance biosolids destruction and gas production; reduce dewatering and beneficial use/disposal costs.

State of Development: Innovative

Recuperative thickening was the subject of a full-scale test at the Spokane, Washington, Advanced Wastewater Treatment Plant from September 2000 to May 2001. Two benefits were reported in the study: (1) Use of existing dissolved air flotation capacity allowed implementation with essentially no capital cost; (2) Co-thickening with waste-activated sludge showed no increase in thickening labor or power costs. Polymer use increased for thickening and decreased for dewatering. Recuperative thickening of 25% of the digesting solids increased solids retention time in the anaerobic digesters from 15.7 days to 24.0 days. Anaerobic digestion volatile solids reduction increased from 50% to 64%. Recuperative thickening did not affect effluent quality.

Description:

Digested biosolids are removed from the anaerobic digestion process, thickened, and returned to the anaerobic digestion process. Anoxic gas flotation is one type of recuperative thickening process, and it is described earlier in this chapter.

Comparison to Established Technologies:

Technology allows for the use of existing biosolids process equipment and does not have the additional capital costs associated with other innovative technologies that require greater capital investments.

Available Cost Information:

Approximate Capital Cost: Not provided by vendor.

Approximate O&M Costs: Not provided by vendor.

Capital and operations and maintenance cost estimates will vary depending on what thickening equipment currently exists at a treatment facility. According to the Spokane study, the net result was a net reduction of polymer requirements by 15% with an annual savings of \$28,000. Biosolids production (wet weight) was reduced 22% with a resultant annual savings of \$85,000. There is no specific equipment to be purchased.

Vendor Name(s):

Not applicable (procedural variation not requiring specific equipment)

Practitioner(s):

The following hosted a demonstration project but is not a current practitioner:
Spokane Advanced Wastewater Treatment Plant
4401 North A.L. White Parkway
Spokane, WA 99205
Phone: 509-625-4600

Technology Summary

Recuperative Thickening (Contd)

Key Words for Internet Search:

Recuperative thickening/thickener, anaerobic digestion

Data Sources:

Reynolds, D.T., M. Cannon, T. Pelton. "Preliminary Investigation of Recuperative Thickening for Anaerobic Digestion." WEFTEC Paper. (October 2001).

Technology Summary

Metal Screen Thickening	
Objective: This equipment performs conditioning and thickening in one basin	State of Development: Embryonic According to Ebara Corporation, a pilot test was conducted in a 24-hour operation biosolids treatment facility for a period of about 1 year. Test results indicated a sludge treatment rate of about 200 kg dissolved solids per hour.
Description: This system employs a set of slit screens with 1-millimeter openings. The screens are installed in a mixing tank. Sludge is thickened by cross-flow filtration through the screens. According to the vendor, this system is designed to prevent clogging (which often occurs with simple screening under atmospheric pressure) with low differential pressure through the submerged screens.	
Comparison to Established Technologies: Not similar to any established technologies.	
Available Cost Information: <i>Approximate Capital Cost:</i> Not provided by vendor. <i>Approximate O&M Costs:</i> Not provided by vendor.	
Vendor Name(s): Not applicable (procedural variation not requiring specific equipment)	Practitioner(s): The following hosted a demonstration project but is not a current practitioner: Spokane Advanced Wastewater Treatment Plant 4401 North A.L. White Parkway Spokane, WA 99205 Phone: 509-625-4600
Key Words for Internet Search: Recuperative thickening/thickener, anaerobic digestion	
Data Sources: Reynolds, D.T., M. Cannon, T. Pelton. "Preliminary Investigation of Recuperative Thickening for Anaerobic Digestion." WEFTEC Paper. (October 2001).	

Stabilization

4.1 Introduction

Biosolids are stabilized to reduce pathogens, eliminate offensive odors and inhibit, reduce or eliminate the potential for putrefaction that leads to odor production. Stabilization also reduces attraction to vectors. Stabilization processes may produce Class A or Class B biosolids, depending on the level and type of stabilization provided. This chapter focuses on the latest developments in stabilization technologies.

4.2 Technology Assessment

Table 4.1 summarizes the state of development of stabilization technologies.

Recent technology developments in this area include several adaptations to the anaerobic digestion process. Temperature-Phase Anaerobic Digestion (TPAnD), Two-Phase Acid/Gas, and Three-Phase Anaerobic Digestion are included as innovative technologies. Figure 4.1 includes an evaluation of the innovative technologies identified. Summary sheets for each innovative and embryonic technology are provided at the end of this chapter.

Table 4.1 – Thickening Technologies—State of Development

Established	Innovative	Embryonic
Aerobic Digestion <ul style="list-style-type: none"> ▪ Autothermal Thermophilic (ATAD) Alkaline Stabilization Advanced Alkaline Stabilization Anaerobic Digestion <ul style="list-style-type: none"> ▪ Dual Digestion ▪ Two-Stage Mesophilic Composting Pasteurization Solidification Synox	Aerobic Digestion <ul style="list-style-type: none"> ▪ Aerobic/Anoxic Digestion Anaerobic Digestion <ul style="list-style-type: none"> ▪ Anaerobic Baffled Reactor ▪ Columbus Biosolids Flow-Through ▪ Thermophilic Treatment ▪ High-Rate Plug Flow (BioTerminator 24/85) ▪ Temperature Phased Anaerobic Digestion ▪ Thermal Hydrolysis (CAMBI Process) ▪ Thermophilic Fermentation (ThermoTech™) ▪ Three-Phase Anaerobic Digestion ▪ Two-Phase Acid Gas Anaerobic Digestion Vermicomposting	Aerobic Digestion <ul style="list-style-type: none"> ▪ Simultaneous Digestion and Metal Leaching Anaerobic Digestion <ul style="list-style-type: none"> ▪ Ozone Treatment Disinfection <ul style="list-style-type: none"> ▪ Ferrate Addition ▪ Irradiation ▪ Neutralizer®

Figure 4.1 – Evaluation of Innovative Thickening Technologies

Process	Evaluation Criteria										Comments
	Development	Applicability	Potential Benefits	Beneficial Use	Impact on Other Processes	Complexity	Air Emissions	Energy	Footprint	Environmental	
Aerobic/Anoxic Digestion	D	F	C,O,V	N/A	▲	⊖	⊖	▲	▲	⊖	Enhances aerobic digestion
Anaerobic Baffled Reactor (ABR)	D	F	C,O,V	N/A	⊖	⊖	⊖	⊖	⊖	⊖	
Columbus Thermophilic Treatment (CBFT3)	N	I	C,O,V	A	▲	▼	⊖	▲	⊖	▲	Retrofits to produce Class A
High-Rate Plug Flow BioTerminator 24/85	P	I	C,O,V	N/A	▲	▼	⊖	⊖	▼	⊖	Requires screening and dewatering
Temperature-Phased Anaerobic Digestion	N	I	C,O,V	A	▲	▼	⊖	▲	⊖	▲	
Thermal Hydrolysis (CAMBI Process)	D	L	C,O,V	N/A	▲	▼	▼	▲	⊖	⊖	Odor issues
Thermophilic Fermentation (ThermoTech™)	I	F	C,O,V	N/A	▲	▼	⊖	▲	▲	⊖	
Three-Phase Anaerobic Digestion	N	I	C,O,V	A	▲	⊖	⊖	▲	▼	▲	
Two-Phase Acid/Gas Anaerobic Digestion	N	I	C,O,V	A	▲	⊖	⊖	▲	▲	▲	Low capital cost
Vermicomposting	N	S	C,O,V	A	▲	▲	⊖	▲	▼	▲	

Statement of Development	Applicability	Potential Benefits	Beneficial Use
B = Bench scale D = Full-scale demonstrations in North America I = Full-scale industrial applications, with demonstrations or pilots for municipal sewage sludge O = Full-scale operations overseas N = Full-scale operations in North America P = Pilot	F = Few plants I = Industrywide L = Primarily large plants S = Primarily small plants	A = Produces Class A biosolids C = Capital savings O = Operational/maintenance savings F = Produces high-nutrient fertilizer M = Minimizes odors R = Provides beneficial use (nonagricultural) V = Sludge volume reduction	A = Agriculture C = Construction N/A = Not Applicable P = Power
Comparative Criteria			
▲ Positive feature ⊖ Neutral or mixed ▼ Negative feature			

Technology Summary

Aerobic/Anoxic Digestion	
<p>Objective: Improve denitrification and enhance aerobic digestion.</p>	<p>State of Development: Innovative Full-scale aerobic/anoxic operation has been evaluated at treatment plants in Castle Rock, Colorado; Paris, Illinois; and Clyde, Ohio. In each case, the result was nearly complete nitrification and the ability to maintain approximately neutral pH values, enhanced digestion, near-complete nitrification, and nitrogen removal.</p>
<p>Description: Aerators in an aerobic digester cycle on and off so that denitrification occurs under the anoxic conditions produced when the aerators are turned off. Aerobic/anoxic digestion results in denitrification, which can provide approximately neutral pH that enhances nitrification, aerobic digestion, and nitrogen removal. Effective pathogen destruction is also observed. Aerobic/anoxic operation at several facilities has allowed the facilities to maintain approximately neutral pH values, enhanced digestion, near-complete nitrification, and nitrogen removal.</p>	
<p>Comparison to Established Technologies: Similar to aerobic/anoxic wastewater treatment nutrient removal technologies. Aerobic/anoxic sludge digestion has been shown to improve sludge dewaterability, filtrate quality, and pH control compared to aerobic digestion alone.</p>	
<p>Available Cost Information: <i>Approximate Capital Cost:</i> Process involved conversion of existing facilities. Vendor does not have unit capital costs. <i>Approximate O&M Costs:</i> Not provided by the vendor.</p>	
<p>Vendor Name(s): Enviroquip, Inc. 2404 Rutland Drive, Suite 200 Austin, TX 78758 Phone: 512-834-6000 Fax : 512-834-6039</p>	<p>Practitioner(s): Plum Creek Wastewater Authority 4255 N US Highway 85 Castle Rock, CO 80108 Phone: 303-688-1991 Fax: 303-688-1992</p>
<p>Key Words for Internet Search: Aerobic-anoxic, biosolids, sludge</p>	
<p>Data Sources: Daigger, G.T. and E. Bailey. "Improving Digestion by Prethickening, Staged Operation, and Aerobic-Anoxic Operation: Four Full-Scale Demonstrations." Water Environment Research. (May/June 2000).</p>	

Technology Summary

Anaerobic Baffled Reactor (ABR)

Objective:

Reduce sludge production by encouraging anaerobic biological degradation of the primary sludge in the primary treatment tank.

State of Development: Innovative

A full-scale pilot plant at Orange County Sanitation District was used to evaluate the performance of an ABR in Southern California. Full-scale prototypes have been constructed in the United Kingdom. The appropriateness of the ABR for on-site primary sanitation in low-income communities in South Africa also has been evaluated.

Description:

An anaerobic baffled reactor (ABR) consists of alternating hanging and standing baffles that compartmentalize the reactor and force liquid flow up and down from one compartment to the next. The compartmentalized design separates the solids retention time from the hydraulic retention time, making it possible to anaerobically treat wastewaters at short retention times (4 – 10 hours).

Comparison to Established Technologies:

Similar to baffled wastewater treatment basins used as a sequence of complete mix reactors. ABR systems have been shown to provide higher resilience to hydraulic and organic shock loads, longer biomass retention times, and lower sludge yields than other high rate anaerobic treatment systems. According to Orange County Sanitation District, volatile solids reduction was not clear from the test data. High BOD in effluent was observed.

Available Cost Information:

Approximate Capital Cost: \$400,000 to retrofit a 4-MGD rectangular primary clarifier with ABR

Approximate O&M Costs: \$10,000 per year

Costs are expected to vary based on rectangular versus circular retrofit.

Vendor Name(s):

Atkins Water
3020 Old Ranch Parkway
Suite 180
Seal Beach, CA 90740
Phone: (562) 314-4231
Email: rupert.kruger@atkinsglobal.com

Practitioner(s):

The following hosted a pilot project but is not a current practitioner:
Orange County Sanitation District
10844 Ellis Avenue
Fountain Valley, CA 92708-7018
Phone: (714) 962-2411
Email: forinformation@ocsd.com

Key Words for Internet Search:

Anaerobic Baffled Reactor, ABR, volatile solids reduction, biosolids

Technology Summary

Anaerobic Baffled Reactor (ABR) (Contd)

Data Sources:

Foxon, K.M., S. Pillay, T. Lalbahdur, N. Rodda, F. Holder and C.A. Buckley. "The anaerobic baffled reactor (ABR): An appropriate technology for on-site sanitation." *Water SA* 30:5 (2004) 44-50.

Kruger, R. and J. Brown. "Large-scale pilot trial of anaerobic baffled reactor: Assessment of key performance parameters and cost-benefit analysis of full-scale retrofit." *Proceedings of the WEF/AWWA Joint Residuals and Biosolids Management Conference, Nashville, Tennessee. (17-20 April 2005)*



ABR installation. Photo courtesy of Atkins Water, 2006.

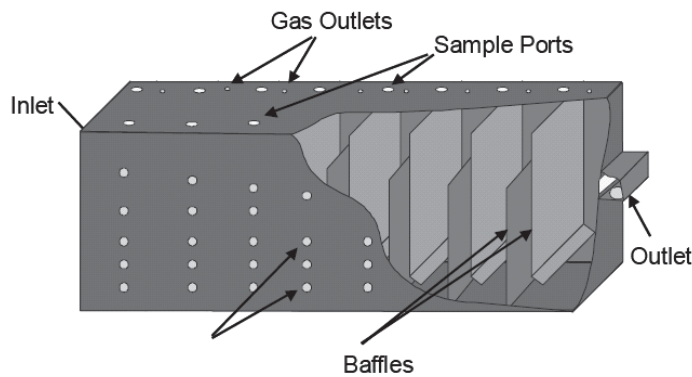

Schematic of ABR unit (Foxon, et al., 2004)

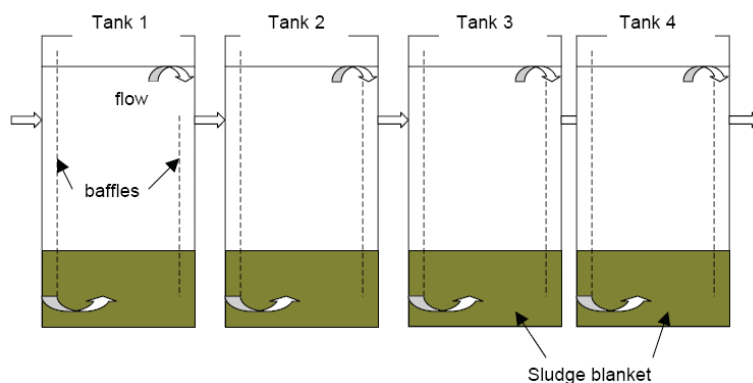

Cross-section of ABR (Kruger and Brown, 2005)

Technology Summary

Columbus Biosolids Flow-Through Thermophilic Treatment (CBFT3)

Objective:

Low-cost way for converting from Class B to Class A biosolids production.

State of Development: Innovative

Columbus Water Works (CWW), Georgia, completed a pilot-scale study of CBFT3 in June 2003 which showed successful production of Class A biosolids at digestion temperatures of 53°C > 6 days and 60°C for 30 minutes with a very specific treatment train. This has received site-specific approval for Class A biosolids production. In addition, testing for Helminth and viruses continue.

Description:

The CBFT3 design consists of a conventional, complete-mix, continuous-feed thermophilic anaerobic digester followed by a long, narrow plug-flow reactor. Mesophilic digestion is then used to minimize odors in the final product. The construction of a plug-flow reactor prototype was completed in February 2004, and ongoing studies are testing its effectiveness. Estimates indicate that the CBFT3 conversion process could save from \$0.6 million for a 5 MGD plant up to \$19 million for a 200 MGD plant. Patent rights of this process were given to the Water Environment Research Foundation (WERF) in 2005.

Comparison to Established Technologies:

An improved process from conventional anaerobic digesters potentially capable of yielding Class A biosolids.

Available Cost Information:

Approximate Capital Cost: \$12,000,000 (for a 90 MGD facility)

Approximate O&M Costs: Not available.

Capital cost estimate is based on construction loan for the South Columbus Water Resource Facility, Georgia. Maintenance activities are completed on an "as-needed" basis, a minimum of once annually.

Vendor Name(s):

Developed by the Columbus Water Works with:
Brown and Caldwell
4700 Lakehurst Court, Suite 100
Columbus, OH 43016
Phone: (614) 410-6144
Fax: (614) 410-3088

Practitioner(s):

Columbus Water Works
1421 Veterans Parkway, P.O. Box 1600
Columbus, GA 31901
Phone: 706-649-3400
Fax: 706-327-3845
Email: mailbox@cwvga.org
Website: www.cwvga.org

Key Words for Internet Search:

Columbus Biosolids Flow-Through Thermophilic Treatment, CBFT3, Columbus Water Works

Technology Summary

Columbus Biosolids Flow-Through Thermophilic Treatment (CBFT3) (Contd)

Data Sources:

Esters, K. "Columbus Water Works honored for technique that turns human waste into safe fertilizer." Water Industry News. (22 February 2005).

Water Environment Research Federation (WERF). "Columbus Retrofits Plants to Achieve Low-Cost Class A Biosolids." Compiled by Roy Ramani in WERF Progress Newsletter –Vol 15: Issue 3. (Summer 2004)

Willis, J. and P. Schafer. "Upgrading to Class A Anaerobic Digestion: Is Your Biosolids Program Ready to Make the Move?" Public Works Magazine. (1 January 2006).

Technology Summary

High-Rate Plug Flow BioTerminator 24/85

Objective:

Reduce total suspended solids of feed sludge by 85% in 24 hours. Generate methane that can be recovered and used for energy

State of Development: Innovative

Pilot studies of the BioTerminator system have been conducted at wastewater treatment plants in Daphne, Alabama; Galveston, Texas; Baton Rouge, Louisiana; and Fort Smith and Little Rock, Arkansas. Based on pilot study results, the BioTerminator appears to achieve exceptional total and volatile solids destruction. The first full-scale application of the BioTerminator technology is scheduled to be installed at the Daphne, Alabama WWTP in 2007.

Description:

The BioTerminator 24/85 anaerobic digester consists of a plug flow insulated tank with a patented arrangement of baffles. The tanks are rectangular in shape with a maximum capacity of 10,000 gallons.

A plant requiring more than the 10,000 gallon feed capacity would need to employ multiple reactors. Prior to entering the tank, the sludge may need to be screened and/or dewatered, and will have to be heated to 35°C (95°F). For some sludges, a minimal amount of carbon supplement, typically sugar, is added as a microbial stimulant. For mixed primary and secondary sludges, sodium bicarbonate is fed if necessary to maintain proper pH.

A portion of the methane generated by the process is used to preheat the sludge (<25%, depending on climate) and the rest may be flared or used to recover energy value. Additional descriptions of the various system components are provided in Burnett (2005).

Comparison to Established Technologies:

According to the vendor, the BioTerminator requires much shorter retention time and achieves a greater reduction in total solids in comparison to a well-operated conventional anaerobic digester. Studies are underway to support these claims.

Available Cost Information:

Approximate Capital Cost: \$1.2 million for first 10,000 gpd reactor and equipment skid
\$400,000 for subsequent two reactors, if added

Approximate O&M Costs: \$15,000/year for chemicals and \$4,000/year electricity
Recoverable energy value of methane, if used, would offset O&M costs

Vendor Name(s):

Shaw Environmental & Infrastructure, Inc.
17 Princess Road
Lawrenceville, NJ 08648
Phone: 609-895-5340

Practitioner(s):

Information on practitioners is available at
www.bioterminator.com/casestudies.phtml.

Key Words for Internet Search:

Anaerobic digester, volatile solids, mesophilic, plug flow, solids reduction, BioTerminator

Technology Summary

High-Rate Plug Flow BioTerminator 24/85 (Contd)

Data Sources:

Burnett, C. "Pilot test results of the BioTerminator high-rate plug flow anaerobic digester." *Proceedings of the WEF/AWWA Joint Residuals and Biosolids Management Conference*, Nashville, Tennessee. (17–20 April 2005).

The website www.totalsolidsolution.com provides information on this technology although this company is no longer a vendor for the BioTerminator system.

Also visit www.shawwatersolutions.com.



Technology Summary

Temperature-Phased Anaerobic Digestion (TPAnD)

Objective:

Improve the quality of biosolids by combining thermophilic and mesophilic anaerobic digestion.

State of Development: Innovative

The Western Lake Superior Sanitary District in Duluth, Minnesota uses the TPAnD system to process solids resulting from the treatment of 40 mgd of wastewater. The technology is also used at Madison, WI and in Orange County and Los Angeles in CA.

Blue Plains Advanced Wastewater Treatment Plant is planning to construct an egg-shaped TPAnD digester facility. The results of studies performed by Virginia Tech comparing a TPAnD system, a two-stage thermophilic system, and two mesophilic conventional digesters recommended that DC WASA continue to pursue TPAnD as a process option for their new anaerobic digestion facility.

Description:

Temperature-phased anaerobic digestion (TPAnD), also referred to as thermophilic/mesophilic digestion, is a promising process option for the wastewater treatment facilities due to its higher performance and ability to control product odor. The process employs thermophilic (>55°C) conditions in the first phase of digestion followed by mesophilic (35°C) conditions in the second phase of digestion.

Comparison to Established Technologies:

A combination of thermophilic digestion and mesophilic digestion processes. By their combined use, the performance is enhanced over either individual process.

Available Cost Information:

Approximate Capital Cost: \$4,700,000

Approximate O&M Costs: Not available.

Capital cost is based on the 2004 estimated cost to install a new 2,465 m³ temperature-phased anaerobic digester, associated piping upgrades, and upgrades to a secondary digester at the Ravensview Water Pollution Control Plant in Kingston, Ontario.

Vendor Name(s):

Not applicable

Practitioner(s):

Western Lake Superior Sanitary District

2626 Courtland St.

Duluth, MN 55806

218-722-3336

Website: www.wlssd.com

Key Words for Internet Search:

Anaerobic digestion, temperature phased, Blue Plains wastewater

Technology Summary

Temperature-Phased Anaerobic Digestion (TPAnD) (Contd)

Data Sources:

J.L. Richards & Associates, Ltd. *Ravensview WPCP Secondary Treatment and Capacity Upgrades Class EA Update*. Technical Memo No. 5 - Biosolids Management Upgrades. Prepared for Utilities Kingston. (May 2004).

Inman D.C., S. Murthy, P. Schafer, P. Schlegel, J. Webb, J.T. Novak. "A comparative study of two-stage thermophilic, single-stage mesophilic, and temperature-phased anaerobic digestion." *Proceedings of the WEF 2005 Residuals & Biosolids Specialty Conference*, Nashville, Tennessee. (17–20 April 2005).

Water Environment Federation Residuals and Biosolids Committee. "High-Performance Anaerobic Digestion (White Paper)". Water Environment Federation, Alexandria, Virginia. (January 2004)

Technology Summary

Thermal Hydrolysis (CAMBI Process)

Objective:

Biosolids mass reduction; increased production of biogas.

State of Development: Innovative

This process was used full scale in 2002 at the Nigg Bay Wastewater Treatment Plant in Aberdeen, Scotland, and is installed at additional wastewater treatment facilities across Europe, Australia and Japan. In Europe, it is also used by pulp manufacturers.

Description:

Prior to digestion, sludge is dewatered to 15%–20% solids and fed through a hydrolysis vessel. The process involves the oxidation of sludge under elevated temperature (approximately 320°F) and pressure (approximately 100 psi). Under these conditions, pathogens are destroyed and cell structures in the sludge breakdown, releasing energy-rich compounds.

Following hydrolysis, sludge is fed to an anaerobic digester where it readily breaks down, resulting in high volatile solids destruction (approximately 65%) and increased biogas production compared to conventional anaerobic digestion.

Odor issues need to be addressed for this process

Comparison to Established Technologies:

Similar to established technology by Zimpro Wet Air Oxidation process. Increased biogas production from hydrolyzed sludge.

Available Cost Information:

Approximate Capital Cost: \$6,000,000

Approximate O&M Costs: \$360 per dry ton treated

Capital and O&M costs are for the installation and 2000–2001 estimated operational costs of the CAMBI process at the 5 MGD Hamar Wastewater Treatment Plant, Norway. Operational costs include operating the treatment plant, disposal of waste biosolids, personnel costs, overhead costs, depreciation, and interest. The Hamar plant accepts biosolids from other treatment plants.

Vendor Name(s):

RDP Technologies, Inc.
2495 Boulevard of the Generals
Norrstown, PA 19403
Phone: 610-650-9900
E-mail: pchristy@rpdtech.com

Practitioner(s):

North of Scotland Water Authority
Denburn House
25 Union Terrace
Aberdeen, Scotland AB10 1NN
Phone: 845-743-7437
For additional practitioners see
www.cambi.com/sludge_frame.asp

Key Words for Internet Search:

Thermal hydrolysis, CAMBI Process, biosolids, sludge

Data Sources:

Stevens, D., Kelly, J., Liston, C., Oemeke, D. Biosolids Management in England and France. *Water*, 29(1):56–61. The Journal of the Australian Water Association. (2002).

Wilson, S. Panter, K. (2002). Operating Experience of Aberdeen CAMBI Thermal Hydrolysis Plant Proceeding of CIWEM/ AQUA Enviro 7th European Biosolids and Organic Residuals Conference. (November 2002).

Vendor-supplied information

Technology Summary

Thermophilic Fermentation (ThermoTech™)

Objective:

Converts sewage sludge and residuals into fertilizer-grade product by thermophilic fermentation process.

State of Development: Innovative

ThermoMaster™ plants in Canada convert food wastes into a high-protein animal feed supplement and wastewater treatment sludges into fertilizer material. This technology is not being actively marketed by the vendor at this time.

Description:

ThermoTech™ is a microbial organic waste digestion technology originally developed to create animal feed supplement from relatively high-solids-content food wastes. The process has been modified for wastewater sludge and materials with a lower solids content. In the ThermoMaster™ process, autoheated aerobic digestion is operated at a relatively short residence time of 30 hours to maximize single-cell protein production using the influent waste material as a substrate. The solids from the digestion process are then dried and pelletized.

Limited information was available on this technology as the vendor is no longer focusing its efforts on marketing this technology.

Comparison to Established Technologies:

Fermenting provides a number of benefits over established technologies, including a 20% increase in protein content and minimal energy requirements (as the process creates its own heat). Residuals are transformed into salable products in less time and with smaller space requirements.

Available Cost Information:

Approximate Capital Cost: \$15,000,000 – \$50,000,000 for a 400-tpd facility

Approximate O&M Costs: Not available.

Vendor Name(s):

ThermoTech™ Technologies
204-195 County Court Boulevard
Brampton, Ontario L8E 5V9 Canada
Phone: 905-451-5522 or 561-2662
Fax : 905-451-5833

Practitioner(s):

No practitioner at this time.

Key Words for Internet Search:

ThermoTech™, ThermoMaster™, waste digestion, autoheated aerobic digestion

Data Sources:

Glenn, Jim. "Nutrient Niches: Marketing Food Residuals As Animal Feed." *Biocycle*. (April 1997) 43-50.

PR Newswire. "ThermoTech™ Ventures, Inc. Signs US Dollars 200 Million Commitment to Secure Long-Term Debt Financing to Build and Operate ThermoMaster Mark II Plants." (2 March 1999).

Technology Summary

Three-Phase Anaerobic Digestion

Objective:

Increase dewaterability, produce Class A biosolids for direct land application, increase biogas production, and reduce odors.

State of Development: Innovative

Three-phase anaerobic digestion was implemented full scale at the Inland Empire Utilities Agency (IEUA) Regional Water Recycling Plant No. 1 (RP-1) in San Bernardino County, California, in November 2000.

Description:

This anaerobic digestion system operates using three phases. The first phase is a volatile fatty acid digester operating at a temperature of 35°C. The second is an anaerobic thermophilic gas digester operating in the range of 50°C to 56°C. The third phase is not heated but remains above 35°C. IEUA received U.S. EPA's approval for Class A Biosolids per Alternative 4 of CFR 503. The following operating parameters apply:

- Phase 1-Minimum HRT of 2 days (monthly average) at temperatures greater than 35°C;
- Phase 2-Minimum HRT of 14 days (monthly average) at temperatures greater than 50°C;
- Phase 2-Minimum HRT of 10 days (daily minimum) at temperatures greater than 55°C;
- Phase 3-Minimum HRT of 4 days (monthly average) at temperatures greater than 35°C.

Comparison to Established Technologies:

Three-phase anaerobic digestion reportedly results in improved pathogen destruction and very high volatile solids reduction and gas production as compared to single stage anaerobic digestion.

Available Cost Information:

Approximate Capital Cost: Not available.

Approximate O&M Costs: \$60 per wet ton treated

Operational and maintenance costs for IEUA include chemicals, labor, miscellaneous materials, power used, natural gas consumed, and power that was generate in its RP-1 facility (a credit). O&M costs do not include laboratory or monitoring costs, collection system or pretreatment costs, any administrative costs, contract labor or professional fees and services. IEUA estimated it saved \$270,000 in energy costs during the first 2 years of operation.

Vendor Name(s):

None identified.

Practitioner(s):

Inland Empire Utilities Agency
 Recycling Plant 1 (RP-1)
 2450 E. Philadelphia Avenue
 Ontario, California 91761
 Phone: 909-993-1800
 Fax: 909-947-2598
 City of Tacoma Wastewater Management
 2101 Portland Avenue
 Tacoma, WA 98421

Key Words for Internet Search:

Three-phase anaerobic digestion, thermophilic digestion, Inland Empire Utilities Agency, IEUA, biosolids

Technology Summary

Three-Phase Anaerobic Digestion (Contd)

Data Sources:

Lee, S.A., D.D. Drury, C.A. Baker, J.S. Bowers, R.H. Nienhuis. "Three-Phase Thermophilic Digestion Disinfects Biosolids." *Biosolids Technical Bulletin*. Water Environment Research Federation. Vol. 8: No. 6. (2003).

Salsali H.R., and W.J. Parker. "An Evaluation of 3 Stage Anaerobic Digestion of Municipal Wastewater Treatment Plant Sludges." *Proceedings of the WEF Residuals and Biosolids Management Conference 2006: Bridging to the Future*, Cincinnati, OH (12–14 March 2006).

Technology Summary

Two-Phase Acid/Gas Anaerobic Digestion

Objective:

Increase methane production and shorten biosolids digestion time.

State of Development: Innovative

Patented process developed by Dr. Samnabuth Ghosh during his tenure at Gas Technology Institute (GTI, also known as Institute of Gas Technology). It has been in operation for more than 10 years at a 12 MGD wastewater treatment plant in DuPage County, Illinois. The treatment generates sufficient methane to power a 1.5 mega watt generator.

Full-scale projects are either installed or underway in Denver, Dallas, Hampton Roads and Baltimore.

Description:

Two-phase anaerobic digestion utilizes an acid stage and a gas stage to break down biosolids. Hydrolysis reactions along with acidification and acetification occur in the acid phase digester where the pH is in the range of 5.5 to 6.0 because of the volatile fatty acid fermentation. The second (gas) stage is where high quality (>650 BTU per cubic foot) methane gas production occurs.

The two-phase anaerobic digestion process (called the HIMET or high-methane process) is based on physically separating two different groups of bacteria into two separate tanks and maximizing their growth by maintaining optimum conditions in each tank for that particular group of bacteria. The first group, the acidogenic bacteria, is grown in the acid phase digester where the pH is in the range of 5.5 to 6.0 because of the volatile fatty acid fermentation. The second group, the methanogenic bacteria, is grown in the methane digester where the pH is naturally much higher and where residence time can be between 7–10 days, depending upon the waste characteristics. The acidogenic bacteria will not thrive in the methane reactor as most of its feed material is used in the acid digester; the methanogenic bacteria cannot thrive in the acid digester as the retention time is too short and the pH is too low.

Comparison to Established Technologies:

This process is similar to fermentation processes. According to one vendor, upsets in conventional anaerobic digesters are often attributable to the methanogenic bacteria, which are difficult to grow and are sensitive to overloads. Two-phase digestion is resilient to changes in feed volume and composition because the acidogenic bacteria are hardy and do well under extreme loading conditions. It is also claimed that the technology minimizes or eliminates foaming problems.

Available Cost Information:

Approximate Capital Cost: Not available.

Approximate O&M Costs: Not available.

Vendor Name(s):

Vendor Name(s):

GTI

1700 S. Mount Prospect Road

Des Plaines, IL 60018

Phone: 847-768-0500

Fax: 847-768-0501

E-mail: enviromscienceandtech@gastechnology.org

Practitioner(s):

Woodridge – Greene Valley Wastewater Facility

7900 South Route 53

Woodridge, IL 60517

Email: Kbuoy@dupageco.org

Phone: 630-985-7400

Website: www.dupageco.org/publicworks/

Key Words for Internet Search:

Two-phase anaerobic digestion, two-stage anaerobic digestion, biosolids, sludge

Technology Summary

Two-Phase Acid/Gas Anaerobic Digestion (Contd)

Data Sources:

Kelly, H.G. Emerging Technologies in Biosolids Treatment. Dayton & Knight Ltd., West Vancouver, Canada. (2003).

GTI. "HIMET – A Two-Stage Anaerobic Digestion Process for Converting Waste to Energy." Company website: www.gastechnology.org. (September 2004).

DuPage County, Illinois, Department of Public Works website. (2005). Woodridge-Greene Valley Wastewater Facility. Available online at www.dupageco.org/publicworks/generic.cfm?doc_id=880.

Technology Summary

Vermicomposting

Objective:

Achieve pathogen reduction, produce a land application-quality compost from biosolids.

State of Development: Innovative

In July 2004, the first full-scale vermicomposting facility in the United States was commissioned for the township of Granville, Pennsylvania. This facility, which treats approximately 70 dry tons annually, processes aerobic digested biosolids.

Description:

Earthworms, added to biosolids, break down organic material and produce a fine-grained castings, considered by some to have greater value as a soil amendment than traditional composts. Generally operated in a semi-continuous flow. The earthworms stay in the bed with no need to restock regularly; generally, the worm population is self regulating and will increase to the point where available food and space constrain further expansion. The process must be monitored for such parameters as moisture content and temperature but is not labor-intensive. Flow of solids into the system is then adjusted to optimize living conditions for the worms. The castings are known to contain plant growth regulators and other substances that make them an effective form of bio-fertilizer and bio-pest control agent.

A full-scale demonstration in Orange County, Florida, showed greater reduction of indicator pathogens in biosolids composted with, versus without, the addition of worms. The Manure Management Program, Cornell University, is currently researching vermicomposting of animal manure.

Comparison to Established Technologies:

Vermicomposting involves earthworms and microorganisms working together. In contrast to conventional aerobic composting, it does not involve a thermophilic stage to achieve stabilization. As with other non-enclosed composting technologies, vermicomposting does have a fairly large footprint similar to aerated static pile composting.

Available Cost Information:

Approximate Capital Cost: \$1,600,000

Approximate O&M Costs: \$495,000

Vendor Name(s):

Vermitech USA Inc.
100 Helen Street
Lewistown, PA 17044
Phone: 717-994-4885
Website: www.vermitech.com
Email: shaun.ankers@vermitech.com

Practitioner(s):

Township of Granville
Junction Wastewater Treatment Facility
100 Helen St.
Lewistown, PA 17044
Email: lcraig@granville-twp.org
Phone: 717-242-1838

Key Words for Internet Search:

Vermicomposting, vermiculture, municipal waste, biosolids, sludge

Technology Summary

Vermicomposting (Contd)

Data Sources:

Eastman, Bruce R. "Achieving Pathogen Stabilization Using Vermicomposting". *Biocycle Journal of Composting*. (November 1999). 62-64.

Slocum, Kelly. "Pathogen Reduction in Vermicomposting." *Worm Digest*. Issue 23. (1999).

Vendor-supplied information



*Granville Township, PA vermicomposting facility
(Photo courtesy of Granville Township)*

Technology Summary

Simultaneous Digestion and Metal Leaching (SSDML)

Objective:

Increase the pathogen reduction and metals solubility during the digestion process.

State of Development: Embryonic

A 2003 pilot-scale study found that the SSDML process was successful in obtaining acidity and oxidation-reduction potential levels within a sludge bioreactor that were greater than necessary for solubilization of toxic metals. Nutrient levels (N, P, K) in the decontaminated sludge were preserved throughout the process. The study also found the process to be effective in reducing odors and indicator bacteria in the sludge.

Description:

The simultaneous sewage sludge digestion and metal leaching (SSDML) process involves the addition of elemental sulfur to biosolids during aerobic digestion. After several days, the pH of the mixture is very low (about 2), which is conducive to increasing the solubility of toxic metals within the biosolids.

Comparison to Established Technologies:

Not similar to other established technologies.

Available Cost Information:

Approximate Capital Cost: Not available.

Approximate O&M Costs: Not available.

Vendor Name(s):

Institut National de Recherche Scientifique
Universite du Quebec
2700 rue Einstein
C.P. 7500
Sainte-Foy, Quebec G1V 4C7
Phone: 418-654-2617
E-mail: tyagi@inrs-ete.uquebec.ca

Practitioner(s):

No practitioner at this time

Key Words for Internet Search:

Metals leaching, SSDML, aerobic digestion, biosolids, sludge

Data Sources:

Blais, J., N. Meunier, G. Mercier, P. Drogui, and R.D. Tyagi. "Pilot Plant Study of Simultaneous Sewage Sludge Digestion and Metal Leaching." *Journal of Environmental Engineering*. 130:5 (2004) 516-525.

Technology Summary

Anaerobic Digestion with Ozone Treatment

Objective:

Break down organic matter in biosolids to increase the effectiveness of anaerobic digestion.

State of Development: Embryonic

The Vranitsky and Lahnsteiner (2002) laboratory-scale study found that the average degradation rate of organic matter increase to 65%, as compared to 45% in a conventional (non-ozonated) system. The study also showed an increase in biogas production of 30%–40% due to the added biological disintegration from the ozone addition. The achieved removal rate of carbon and nutrients decreased, but remained within regulatory requirements.

Description:

Anaerobically digested biosolids are diverted from the digester to a reaction tank where they are exposed to low levels of ozone. One experiment by Vranitsky and Lahnsteiner (2002) showed that only 0.06 g of ozone per gram of dissolved solids was necessary to destroy the biological activity of the digested biosolids. The ozonated biosolids are then sent to the thickening tank and then back to the digester where they are mixed with both ozonated and non-ozonated biosolids. The biosolids either exit the digester to be dewatered, or they are again diverted back to the ozone reactor. The ozone generation is based on corona discharges that are capable of transforming molecular oxygen into ozone.

Comparison to Established Technologies:

Not similar to other established technologies.

Available Cost Information:

Approximate Capital Cost: Not available.

Approximate O&M Costs: \$1700 per million gallons treated

Operational cost estimate is based on a model wastewater treatment plant treating approximately 5 million gallons per day using an ozonation plant unit capable of producing 42.3 pounds of ozone per hour.

Vendor Name(s):

American Air Liquide
2700 Post Oak Blvd., Suite 1800
Houston, TX 27056
Phone: 800-820-2522
Website: www.us.airliquide.com

Practitioner(s):

No practitioner at this time

Key Words for Internet Search:

Ozone treatment, ozonation, biosolids, sludge

Data Sources:

Vranitsky, R., J. Lahnsteiner. "Sewage sludge disintegration using ozone – a method of enhancing the anaerobic stabilization of sewage sludge." Proceedings of the European Biosolids and Organic Residuals Workshop, Conference and Exhibition. (2002).

European Environmental Press. "Europe: Using Ozone to Reduce Sludge." (2005)

Water and Wastewater.com. Available online at

www.waterandwastewater.com/www_services/news_center/publish/article_00540.shtml. March 31.

Vendor-supplied information

Technology Summary

Ferrate Addition

Objective:

Stabilization and disinfection of wastewater solids as well as enhancement of biosolids products increasing beneficial use potential.

State of Development: Embryonic

Pilot-scale investigation was conducted using solids from a Washington DC area wastewater treatment plant.

Description:

Ferrate is a powerful oxidizing chemical with a higher reactivity than traditional oxidants. As a liquid, ferrate can be injected into the process stream without the addition of special mixing equipment. One study by the USDA showed dosing dewatered solids with ferrate inactivated 99.9% of *E. coli*. The resulting pH of the disinfected solids is generally between 12 and 13 depending on dose. Ferrates also have been shown to have an affinity to react with sulfides, mercaptans and alkyl amines, all odor-producing compounds common in wastewater solids.

Comparison to Established Technologies:

Depending on use of the ferrate, the process can be compared to various processes where a chemical is added to wastewater solids to increase the potential for beneficial use.

Available Cost Information:

Approximate Capital Cost: Not provided by the vendor.

Approximate O&M Costs: Ferrate liquid is available for approximately \$2 per pound

Vendor Name(s):

Ferrate Treatment Technologies, LLC
6432 Pine Castle Blvd, Unit #2C
Orlando, FL 32809
Phone: 407-857-5721
Fax : 407-826-0166
E-mail: calig@ferrate.biz
Website: www.ferratetreatment.com

Practitioner(s):

No practitioner at this time.

Key Words for Internet Search:

Ferrate, biosolids, sludge

Data Sources:

Chao, A. Quality Improvement of Biosolids by Ferrate (VI) Oxidation of Offensive Odour Compounds." IWA Publishing Journal Online at www.iwaponline.com/wst/03303/wst033030119.htm. 8 August 2006.

Kim, H. P. Millner, V. Sharma, L. McConnell, A. Torrents, M. Ramirez, C. Peot. "Ferrate: Nature's Most Powerful Oxidizer: It's Potential As a Disinfection Treatment for Thickened Sludge." Research Notes published at www.ars.usda.gov/research/publications/publications.htm?SEQ_NO_115=190364. 8 August 2006.

Reimers, R.S., V.K. Sharma, S.D. Pillai, and D.R. Reinhard. "Application of Ferrates in Biosolids and Manure Management with Respect to Disinfection and Stabilization." *WEF/AWWA Joint Residuals and Biosolids Management Conference 2005*, Nashville, Tennessee (17-20 April 2005).

Technology Summary

Irradiation	
Objective: Biosolids disinfection	State of Development: Embryonic Beta and gamma irradiation have been tested for at least 20 years based on the promise of their low space requirement; however, to date irradiation methods have not been implemented on a continuous full-scale basis at any wastewater treatment plants in the United States.
Description: Irradiation destroys organisms by altering the colloidal nature of cell protoplasm. Gamma rays are high-energy photons produced by certain radioactive elements; beta rays are electrons accelerated in velocity by electrical potentials in the vicinity of 1 million volts. Both types of radiation destroy pathogens; however, the effectiveness of beta radiation is dependent on the dose. A dose of 1 megarad or more at 2°C will reduce pathogenic viruses, bacteria, and helminthes to below detectable levels. Lower doses may successfully reduce bacteria and helminth ova but not viruses. Gamma rays from isotopes such as 60Cobalt and 137Cesium (at 1 megarad at 20°C) can penetrate substantial thicknesses and are easier to expose to sludge. Beta rays have limited penetration ability and therefore are introduced by passing a thin layer of sewage sludge under the radiation source. Because these processes, when used alone, do not reduce nuisance odors and the attraction of vectors, they are considered supplementary to typical stabilization and pathogen treatment processes.	
Comparison to Established Technologies: Low space requirement is an advantage irradiation offers. However, irradiation does not “stabilize” sludge to satisfy vector attraction reduction (VAR) requirements of U.S. EPA. An alternate approach is to incorporate the biosolids material into the soil within 8 hours, or lime can be added, an established method of vector attraction management.	
Available Cost Information: <i>Approximate Capital Cost:</i> Not available. <i>Approximate O&M Costs:</i> Not available.	
Vendor Name(s): No vendors at this time	Practitioner(s): No practitioner at this time.
Key Words for Internet Search: Ferrate, biosolids, sludge	
Data Sources: Pennsylvania Department of Environmental Protection. Training Course. “Biosolids – Characteristics and Treatment.” (1998). Available online at www.dep.state.pa.us/dep/biosolids/training/index.htm	

Technology Summary

Neutralizer®

Objective:

Disinfection of wastewater solids.

State of Development: Embryonic

The process has been tested in the laboratory on aerobically digested, anaerobically digested and raw solids. It has also been pilot tested at the Lagoon Wastewater and Sludge Facility, St. Thomas, U.S. Virgin Islands. Research has demonstrated the reduction of fecal coliforms and viral densities to below detectable limits and the viability of helminth eggs to 0%. The process has been tested on both raw and digested solids.

Description:

Neutralizer® is a sequenced batch process. First, chlorine dioxide is added to solids as they are fed into a mixing tank. Continuous mixing is provided during this initial two-hour contact time. Next, sulfuric acid is added to acidify the solids to a pH of between 2.3 to 3.0. Then sodium nitrite (which converts to nitrous acid at this pH) is added to the tank. The tank is completely filled to eliminate head space. The pressure in the tank builds to between 15 and 25 psig due to the acidification of the solids and generation of nitrous acid gas. The material is held for another two hour period with continuous mixing. After the two hour period, the pH of the material can be adjusted to create a biosolids favorable for beneficial use.

Comparison to Established Technologies:

Similar to Synox process but uses chlorine dioxide and nitrous acid instead of ozone. Chlorine dioxide is less expensive and more reliable than ozone.

Available Cost Information:

Approximate Capital Cost: varies with application; contract vendor for specific cost information

Approximate O&M Costs: varies with application; contract vendor for specific cost information

Vendor Name(s):

BioChem Resources
3540 Agricultural Center Drive
St. Augustine, FL 32092
Phone: 904-607-2223
Fax : 904-607-9224
E-mail: ws@biochemresources.com

Practitioner(s):

No practitioner at this time.

Key Words for Internet Search:

Neutralizer®, biosolids, sludge

Data Sources:

Reimers, R.S., L.S. Pratt-Ward, H.B. Bradford, F.P. Jussari and W. Schmitz. "Development of the Neutralizer® Process for Disinfection and Stabilization of Municipal Wastewater Residuals." *WEF/AWWA Joint Residuals and Biosolids Management Conference 2006*, Cincinnati, Ohio (12–14 March 2006).

Dewatering

5.1 Introduction

Dewatering removes water from biosolids making them easier and less expensive to transport, dry, compost, or incinerate. Dewatering is most often accomplished by drying beds or a physical process that separates water from the solids via presses or centrifuges. Often chemicals are used to enhance the processes. This chapter focuses on the emerging dewatering technologies.

5.2 Technology Assessment

Table 5.1 summarizes the state of development of dewatering technologies.

Physical separation techniques have dominated the practice of dewatering for decades. Recent advancements in dewatering use electricity rather than, or in combination with, mechanical devices. Electroacoustical, electroosmotic, and electrodewatering are three such processes. Membrane and tubular filter presses have had some reported success in overseas dewatering applications; however, these technologies have yet to gain popularity in the United States. Two more dewatering systems, DAB and Simon Moos, may be promising technologies for small wastewater treatment plants and septage dewatering applications.

Figure 5.1 includes an evaluation of the innovative technologies identified. Summary sheets for each innovative and embryonic technology are provided at the end of this chapter.

Table 5.1 – Dewatering Technologies—State of Development

Established	Innovative	Embryonic
Belt Filter Press Centrifuge Chamber Press Drying Beds <ul style="list-style-type: none"> ▪ Auger-Assisted ▪ Natural Freeze-Thaw ▪ Vacuum-Assisted Vacuum Filters	Drying Beds <ul style="list-style-type: none"> ▪ Quick Dry Filter Beds Electrodewatering Metal Screen Filtration <ul style="list-style-type: none"> ▪ Inclined Screw Press Textile Media Filtration <ul style="list-style-type: none"> ▪ Bucher Hydraulic Press ▪ DAB™ System ▪ Geotube® Container 	Electrodewatering <ul style="list-style-type: none"> ▪ Electroacoustic ▪ Electroosmotic Membrane Filtration <ul style="list-style-type: none"> ▪ Membrane Filter Press Textile Media Filtration Simon Moos <ul style="list-style-type: none"> ▪ Tubular Filter Press Thermal Conditioning and Dewatering <ul style="list-style-type: none"> ▪ Mechanical Freeze-Thaw

Figure 5.1 – Evaluation of Innovative Dewatering Technologies

Process	Evaluation Criteria										Comments
	Development	Applicability	Potential Benefits	Beneficial Use	Impact on Other Processes	Complexity	Air Emissions	Energy	Footprint	Environmental	
Quick Dry Filter Beds	N	S	C,O,V	N/A	▲	⊖	⊖	▲	▲	⊖	
Electrodewatering	B,P	F	V	N/A	▲	⊖	⊖	▼	⊖	⊖	
Inclined Screw Press	N	I	V,R	N/A	▲	▲	⊖	▲	▼	⊖	
Bucher Hydraulic Press	O	S	C	N/A	▲	▲	⊖	▲	⊖	⊖	
DAB™ System	N	S	C,O	N/A	⊖	▲	⊖	▲	▲	⊖	Similar to thickening
Geotube® Container	N	F	C,O,V	N/A	▲	⊖	⊖	▲	⊖	⊖	

Statement of Development B = Bench scale D = Full-scale demonstrations in North America I = Full-scale industrial applications, with demonstrations or pilots for municipal sewage sludge O = Full-scale operations overseas N = Full-scale operations in North America P = Pilot	Applicability F = Few plants I = Industrywide L = Primarily large plants S = Primarily small plants	Potential Benefits A = Produces Class A biosolids C = Capital savings O = Operational/maintenance savings F = Produces high-nutrient fertilizer M = Minimizes odors R = Provides beneficial use (nonagricultural) V = Sludge volume reduction	Beneficial Use A = Agriculture C = Construction N/A = Not Applicable P = Power
Comparative Criteria ▲ Positive feature ⊖ Neutral or mixed ▼ Negative feature			

Technology Summary

Quick Dry™ Filter Beds

Objective:

Drying biosolids to a higher solids percentage – 30%–60% dry cake

State of Development: Innovative

Drying beds with a difference in the drainage system and under bed construction.

Description:

The Quick Dry filter bed process consists of a series of pipes laid on the base of a bed to provide drainage and to presaturate water to enter the bed before the sludge is applied. These pipes are then covered with 20–25 mm rock. A honeycomb grid is placed on the base rock, filled with 10–15 mm rock and covered with a final layer of sand to complete the bed. The Quick Dry process also includes a flocculation system (RapidFloc Mixer), an in-line polymer preparation system that injects polymer into the flocculation device, and a self-contained harvesting unit.

Deskins Quick Dry filter bed is based on rapid gravity drainage with further water removal by natural solar evaporative processes. The Quick Dry media prevents compaction of the filtering media in conventional sand drying beds. Saturation of the bed forces out any air that has been trapped in the filter media and allows the sludge to flow evenly across the bed surface to achieve maximum distribution. When the underdrain is opened, a vacuum or siphoning effect is created and causes the rapid dewatering of the sludge. Along with this cracking or “opening up” of the sludge occurs and allows air to circulate around the cake and further increase drying. Around 90% of the water will exit in 12 hours and the sludge will continue to drain while it is on the bed. Results of several trials produced a cake of 45%–60% dry.

Comparison to Established Technologies:

Compares favorably with mechanical dewatering systems such as a belt filter press or centrifuge. Performs better than existing drying beds. Dewateres solids to greater than 50% within 5–7 days on a footprint about 30% of the size of standard drying beds.

Available Cost Information:

Approximate Capital Cost: Not provided by vendor.

Approximate O&M Costs: Not provided by vendor.

Vendor Name(s):

F D Deskins Company, Inc.

23 Fairway Drive

Alexandria, Indiana 46001

Phone: 765-724-7878

Fax : 765-724-7267

E-mail: deskins@netdirect.net

Practitioner(s):

McAllen Public Utilities

4001 N Bentsen Road

McAllen, TX 78504-9790

City of Casey

108 Main Street

Casey, IL 62420

Technology Summary

Quick Dry™ Filter Beds (Contd)

Key Words for Internet Search:

Deskins, Quick Dry filter bed, polymer mixing, floc

Data Sources:

Evans, Anthony. *Biosolid Reduction and the Deskin Quick Dry Filter Bed*. Australia Water Industry Operators Association Annual Conference Proceedings (220) www.wioa.org.au/conf_papers/02/paper10.htm

Fraser, Ross. *Latest Advance in Solids Dewatering*.



Deskins Quick Dry Filter Bed



Polymer Preparation Unit



Rapid Flocculation Mixer



Dried Solids Harvesting Unit

Technology Summary

Electrodewatering

Objective:

Enhance conventional dewatering using electric current.

State of Development: Innovative

Electrodewatering has been attempted by a variety of groups since the 1920s. A bench-scale demonstration was conducted by the Electric Power Research Institute (EPRI). An electroacoustic dewatering process using electric and ultrasonic fields that improved water removal over a conventional belt filter press by approximately 8% was demonstrated. Until recently, very little work has been done to develop a suitable system capable of meeting full-scale requirements, or to optimize such a system.

Description:

A direct current (DC) voltage is applied to the biosolids mixture. The application of the current in the initial stages of dewatering causes particles to migrate to the electrode of opposite charge (i.e., electrophoresis). Once a cake is formed, electroosmosis occurs as ions migrate to the appropriate electrode to compensate for particle charges. Electrodewatering can be combined with conventional filter presses. According to a recent study by the Water Environment Research Foundation (WERF), the cost benefit of electrodewatering is likely to be greatest for sludge that does not respond well to traditional pressure filtration. The study demonstrated that the novel electrodewatering technique is applicable to a wide range of sludges and indicated that performance might be limited for sludges with high conductivities.

Comparison to Established Technologies:

Not similar to any established technologies. May be combined with filter presses to enhance the thickening of highly conductive sludges.

Available Cost Information:

Approximate Capital Cost: Approximately \$5.25 million to retrofit 30 belt filter presses.

Approximate O&M Costs: \$5,100 –\$24,200 per dry ton

Operation and maintenance costs include electricity (\$70–\$140 per dry ton), labor (\$9–\$29 per dry ton), and maintenance (\$5,000–\$24,000 per dry ton). Cost savings anticipated over conventional dewatering costs.

Vendor Name(s):

Waste Technologies of Australia
Environmental Biotechnology CRC Pty Ltd
Suite G01 Bay 3 Locomotive Workshop
Australian Technology Park
Everleigh NSW 1430
Phone: +61 (0) 2 9209 4963
Website: www.wastetechnologies.com

Practitioner(s):

Electric Power Research Institute (EPRI)
3412 Hillview Avenue
Palo Alto, CA 94304
Phone: 800-313-3774
E-mail: askepri@epri.com
Website: www.epri.com

Technology Summary

Electrodewatering (Contd)

Key Words for Internet Search:

Electrodewatering, EPRI, biosolids, sludge

Data Sources:

Electric Power Research Institute (EPRI). "Emerging Environmental Technologies: An Analysis of New Treatment Technologies for the California Energy Commission." Palo Alto, California, California Energy Commission, Sacramento, California. 1007411. (2003).

Water Environment Research Foundation (WERF). "Demystifying the Dewatering Process: New Techniques and Technologies Shed Light on a Complex Process." WERF Progress Newsletter. WERF, Alexandria, Virginia. (April 2006). Available online at: www.werf.us/press/spring06/dewatering.cfm.

Vendor-supplied information.

Technology Summary

Inclined Screw Press

Objective:

Provide cost-effective dewatering with simplified operations and lower polymer usage.

State of Development: Innovative

The City of Old Town, Maine installed the first permanent inclined screw press in the United States in 2003 as part of a major plant upgrade. In the first year of operation, the inclined screw press successfully met its design criteria and demonstrated that it is a viable and cost-effective dewatering option. Inclined screw presses have since been installed in Utah and other installation projects are underway.

Description:

Liquid sludge (mixture of primary and secondary solids at 1½ to 2%) is pumped to a flocculation reactor. A polymer is introduced through a dosing ring in the feed sludge line and is mixed with the sludge in a static inline mixer.

Flocculated sludge overflows into an inclined screw (~20°) rotating inside a stainless steel, wedge wire screen (200 micron). As the sludge is advanced up the rotating screw, filtrate flows out through the screen. The frictional force at the sludge/screen interface coupled with increased pressure caused by the outlet restriction produces the dewatered sludge cake. The screw flights are provided with a brush for continuous internal cleaning of the screen. The screen basket is also cleaned periodically with spray water from the outside. Spray bars rotate around the basket, but within the enclosure of the press.

A lower and wider section of the basket serves as predewatering zone where free water drains by gravity. A second section of the basket with a reduced diameter serves as a pressure zone. Here the sludge is compressed between narrowing flights of the screw. The pressure in the pressure zone is controlled by the position of a cone at the discharge end of the basket. The dewatered sludge is driven through a gap between the cone and the basket. The dewatered sludge cake (at about 20% to 25% solids) drops on a conveyor or directly into a dumpster.

Two or three screw presses can be installed in parallel, with a single feed pump, polymer station, and flocculation reactor.

Comparison to Established Technologies:

The slow rotational speed results in less noise, vibration and overall wear, reducing anticipated long-term maintenance costs. The unit is constructed of stainless steel and is fully enclosed, reducing the corrosion potential and assisting with containing odors and improving working conditions. In addition, the operation of the unit is fully automated, reducing operational costs as compared to more traditional technologies.

Available Cost Information:

Approximate Capital Cost: Not Available

Approximate O&M Costs: Not available

Vendor Name(s):

Huber Technology, Inc.
9805 North Cross Center Court, Suite H
Huntersville, NC 28078
Phone: 704-949-1010
Fax: 704-949-1020
www.huber-technology.com

Practitioner(s):

City of Old Town
Pollution Control Facility
150 Brunswick Street
Old Town, Maine 04468
Phone: 207-827-3970
Fax: 207-827-3964

Technology Summary

Inclined Screw Press (Contd)

Key Words for Internet Search:

Inclined screw press, dewatering, biosolids, sludge, City of Old Town Maine

Data Sources:

Atherton, P.C., R. Steen, G. Stetson, T. McGovern, and D. Smith. "Innovative biosolids dewatering system proved a successful part of the upgrade to the Old Town, Maine water pollution control facility." Proceedings of the 2005 WEFTEC: The Water Quality Event, Washington, DC. (30 October – 2 November 2005) 6650-6665.

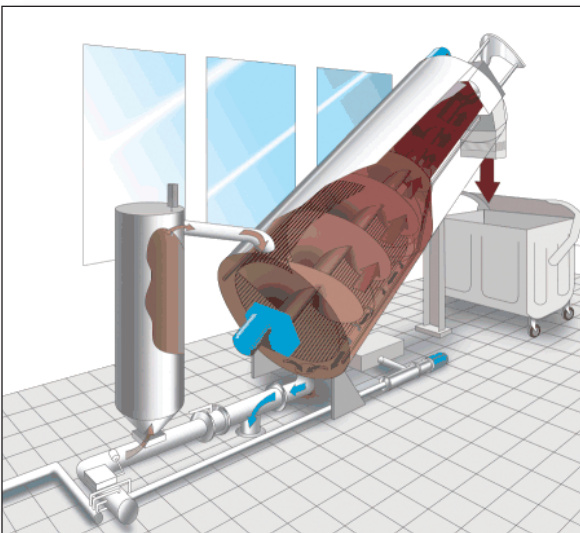

*Schematic of Incline Screw Press.
Image courtesy of Huber Technology, Inc., 2006*



*Installed incline screw press at Old Town Water Pollution
Control Facility. (Atherton et al., 2005)*

Technology Summary

Bucher Hydraulic Press

Objective:

Increase cake solids content in biosolids with lower energy requirements than typical dewatering processes.

State of Development: Innovative

The Bucher hydraulic de-juicing press was tested side-by-side with the existing belt filter presses on digested biosolids as well as digested manure at the Inland Empire Utilities Agency (IEUA) Regional Plant Number 1 (RP-1). The press was also tested at the Big Bear Area Regional Wastewater Authority for dewatering undigested oxidation ditch sludge.

The Bucher press is widely used in Europe and North America in food and beverage processing applications. Industrial-scale trials of hydraulic press sludge dewatering also have been conducted at solids treatment plants in Switzerland and Germany.

Description:

The Bucher press is a hydraulic dejuicing press consisting of a cylinder and a moving piston that squeezes the sludge allowing the water to pass through several filter elements made of porous cloth material. The sludge cake is retained inside the cylindrical shell. After the sludge enters the cylinder, it is continuously squeezed by the piston, thereby achieving a high degree of mechanical dewatering. Filtrate can be collected and discharged to the wastewater system.

Comparison to Established Technologies:

Side-by-side testing results with a belt filter press indicated that a hydraulic press can improve the biosolids and manure cake solids content by more than 25% compared to the belt filter press. The chemical conditioning requirements for the hydraulic press were similar to the belt filter press.

Available Cost Information:

Approximate Capital Cost: Not provided by vendor.

Approximate O&M Costs: Not provided by vendor.

Vendor Name(s):

Atkins Water
3020 Old Ranch Parkway, Suite 180
Seal Beach, CA 90740
Phone: 562-314-4231
Email: rupert.kruger@atkinsglobal.com

Practitioner(s):

The following tested the technology but is not a current practitioner.
Inland Empire Utilities Agency
Recycling Plant 1
2450 E. Philadelphia Avenue
Ontario, California 91761
Phone: 909-993-1800
Fax: 909-947-2598

Technology Summary

Bucher Hydraulic Press (Contd)

Key Words for Internet Search:

Hydraulic press, dewatering, sludge

Data Sources:

Kolisch G., M. Bohler, F.C. Arancibia, D. Pinnow, W. Krauss. "A new approach to improve sludge dewatering using a semi-continuous hydraulic press system." *Water Science Technology*, 52:10-11(2005) 211-8.

Soroushian, F., Y. Shang, E.J. Whitman, and R. Roxburgh. "Biosolids and manure dewatering with a hydraulic de-juicing press." Proceedings of the WEF/AWWA Joint Residuals and Biosolids Management Conference, Cincinnati, Ohio (12–15 March 2006).

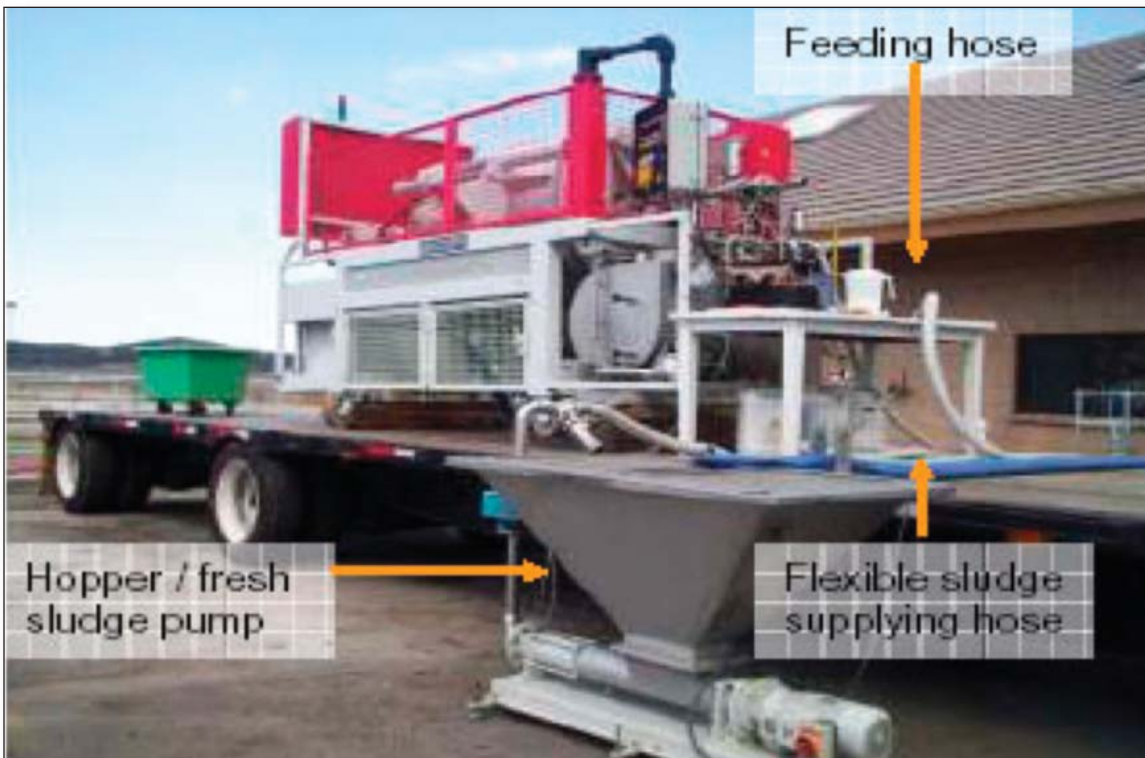

Bucher Hydraulic Press. (Soroushian et. al., 2006)

Technology Summary

DAB™ System

Objective:

Provide low-cost, low-maintenance dewatering.

State of Development: Embryonic

More than 20 DAB™ systems are operating around the world; seven are located in Quebec. Several are operating in Sweden, where the technology originated. DAB™ system installed at the Bowhouse Wastewater Treatment Works in Scotland has been operating successfully for 7 years.

Description:

The DAB™ dehydration unit consists of a conical gravity flow filtration-drainer mechanism that separates sludge liquids and solids, removing most of the free water from the sludge and producing a 90% solids product. The drainer consists of a double-walled cylinder of fine mesh filter medium on a stainless steel frame.

The mechanism is immersed in flocculated sludge. The filtrate flows by gravity in the space between the medium. Additional batches of flocculated sludge are added to the cone. The extra weight compresses the sludge at the base of the silo, increasing solids concentration. The filter medium is kept clean by an internal high-pressure jet system. Batches can be added several times a day, and thickened sludge withdrawn from the base of the tank. Depending on climate, it is not necessary to install the DAB™ unit in a building.

Comparison to Established Technologies:

Similar to an Imhoff tank with a vacuum filtration step to further reduce the water content of the solids.

Available Cost Information:

Approximate Capital Cost: \$150,000 for a 10-m³ unit to \$175,000 for a 25-m³ unit.

Approximate O&M Costs: \$8–\$12 per m³ of sludge treated.

A 10-m³ unit can dehydrate up to 130 m³/day (34,000 gal/day) of septic tank sludge, a 25 m³ unit can treat up to 240 m³/day (63,000 gal/day). Note: costs vary with currency conversion rate; consult with vendor for current cost information. Construction and installation requires 2 to 3 months.

Vendor Name(s):

GSI Environment
855 Pépin
Sherbrooke, Québec J1L 2P3
Phone: 819-829-2717
Fax: 819-829-2717
E-mail: shebriije@gsienv.ca

Practitioner(s):

No practitioner at this time.
Scottish Water
P.O. Box 8855
Edinburgh, Scotland EH10 6YQ
www.scottishwater.co.uk

Key Words for Internet Search:

DAB™ dewatering, GSI Environmental Quebec, biosolids, sludge.

Data Sources:

Vendor-supplied information

Rand, Chris (Editor). "East of Scotland Water cuts treatment costs." Published online in *Engineeringtalk* by Simon-Hartley at www.engineeringtalk.com/news/sim/sim102.html. (21 August 2000).

Technology Summary

Geotube® Container

Objective:

Provide on-site, low-maintenance, cost-effective dewatering.

State of Development: Innovative

Geotextile tubes have been used in the past to contain and dewater dredge materials from shipping harbors. Studies in California, Georgia, Ohio, and New Hampshire have shown improved dewatering of fine grained sewage sludge, successful containment of odors during dewatering, reduction in effluent suspended solids, and cost savings resulting from the use of Geotube® containers.

Description:

Geotube® brand geotextile tubes are comprised of high-strength polypropylene fabric and are fabricated to the project's requirements. The tube is filled by a pumping system conveying sludge material. The geosynthetic tube retains fine-grain fill material while allowing effluent water to permeate through the tube wall. With the addition of a chemical conditioning agent (i.e., a polymer), excess water drains from the Geotube® container through the geotextile resulting in effluent that is, according to the manufacturer, clear and safe enough to be returned to the plant. Volume reduction within the container allows for repeated filling. After the final cycle of filling and dewatering, retained fine grain materials continue to consolidate by desiccation because residual water vapor escapes through the geotextile. The dried biosolids are removed from the tube when retained solids meet dryness goals.

Comparison to Established Technologies:

A recent study of a Geotube® installation at a Midwestern WWTP stated that, compared to the previous year's belt press operations, the Geotube® dewatering system required little to no operation and maintenance time. A belt press or centrifuge requires full-time monitoring and constant adjusting with fluctuating influent conditions. However, if sufficient time is not available for a Geotube® system to dewater stored biosolids, a mechanical dewatering technique may be required. With a belt filter press, biosolids are open to the air where they can release odors or spill off the belt, and belt presses are often noisy. The closed-loop Geotube system reduces odors, the potential for spills, and general biosolids handling. Geotube® systems can be run through all seasons as long as the polymer delivery lines do not freeze. Mechanical dewatering systems are often in climate-controlled buildings and freezing is not an issue.

Available Cost Information:

Approximate Capital Cost: Approximately \$0.03/gallon of biosolids for the first 150,000 gallons. Includes one 60-ft-circumference by 100-ft-long Geotube® container, a polymer make-down system, 1,350 pounds of polymer, bench testing, and technical assistance during start-up.

Approximately \$0.02/gallon of biosolids for 250,000 gallons more. A more shear-resistant polymer and an additional 60-ft by 100-ft Geotube® container were added to the system described above for the subsequent 250,000 gallons of biosolids.

Approximate O&M Costs: Not Available.

Excavation, transportation, and disposal of dried solids were not included in calculation of project costs, as these costs would fluctuate depending on the percent solids in the containers and final mass disposed of at the landfill.

Technology Summary

Geotube® Container (Contd)

Vendor Name(s):

Miratech
 A Division of Ten Cate Nicolon
 3680 Mount Olive Road
 Commerce, Georgia 30529
 Phone: 706-693-1897
 Fax: 706-693-1896
 Website: www.geotubes.com

Practitioner(s):

Saticoy Sanitary District
 1001 Partridge Drive, Suite 150
 Ventura, CA 93003-0704
 Phone: 805-658-4605

City of Cambridge WWTP
 Cambridge, OH
 Phone: 740-432-3891

The vendor's website includes case studies for several practitioners.

Key Words for Internet Search:

Geotube containers, geotextiles, thickening and dewatering, polymers, biosolids, sludge

Data Sources:

Mastin, B.J. and G.E. Lebster. "Dewatering with Geotube® Containers: A Good Fit For A Midwest Wastewater Facility?" Proceedings of the WEF/AWWA Joint Residuals and Biosolids Management Conference, Cincinnati, Ohio. (12–15 March 2006).

Miratech™ Division, Ten Cate Nicolon. 2006. Company website, www.geotubes.com.

WaterSolve, LLC. 2006. Company website, www.gowatersolve.com/geotube.htm.



Geotube® Container at Cambridge WWTP after being filled with 250,000 gallons of biosolids. (Mastin and Lebster, 2006).



The phases of Geotube® Container operation. Image from Watersolve, LLC, 2006.

Technology Summary

Electroacoustic Dewatering

Objective:

Enhance dewatering of biosolids by combining electrical fields and ultrasound waves.

State of Development: Embryonic

Batelle Laboratories has conducted bench-scale studies on electroacoustical dewatering, and as a result have designed a commercial prototype belt filter press.

Description:

The combination of electrical fields and ultrasound waves has been shown to enhance dewatering. The electrical field allows for increased electrophoresis and electroosmosis, and the acoustical force of the ultrasound waves help maintain electrical continuity throughout the biosolids. It has also been shown in bench-scale studies that the ultrasonic waves decrease specific energy consumption, increase the filtration rate, and reportedly help keep the cathode clean.

Comparison to Established Technologies:

Tests of the prototype on four different types of wastewater sludges showed solid contents were increased by 3.4% to 10.4% over conventional dewatering, with final solids concentrations of 23% to 29%.

Available Cost Information:

Approximate Capital Cost: Not available

Approximate O&M Costs: \$19 to \$27 per ton of dry solids

Operational cost estimate is based on the energy costs for a bench-scale study by Batelle Laboratories.

Vendor Name(s):

OilTrap Environmental
(markets Electro-Pulse)
2775 29th Avenue SW
Tumwater, WA 98512
Phone: 360-943-6495
Fax : 360-943-7105
E-mail: support@oiltrap.com

Practitioner(s):

No practitioner at this time.

Key Words for Internet Search:

Electroacoustic dewatering, Electro-Pulse, electrodewatering, biosolids, sludge

Data Sources:

Abu-Orf, M., Muller, C.D., Park, C., and Novak, J.T. "Innovative Technologies to Reduce Water Content of Dewatered Municipal Residuals." *Journal of Residuals Science & Technology*. 1:2 (2001) 83-91.

Technology Summary

Electroosmotic Dewatering

Objective:

Enhance conventional dewatering using electric current.

State of Development: Embryonic

This phenomenon has been successfully used in the ceramics industry for product dewatering, as well as in the construction industry for soil dewatering at building foundations. Researchers have used this process on a bench scale to dewater a variety of agricultural products, including animal manure, without the drawbacks of thermal water removal.

Description:

This technology uses an imposed electric field to force ionic particles in a biosolids mixture to migrate to their attractive electrodes.

Comparison to Established Technologies:

Not comparable to established technologies.

Available Cost Information:

Approximate Capital Cost: Not available

Approximate O&M Costs: Not available

Vendor Name(s):

Not available

Practitioner(s):

The following tested this technology but is not a current practitioner.

Electric Power Research Institute (EPRI)

3412 Hillview Avenue

Palo Alto, CA 94304

Phone: 800-313-3774

E-mail: askepri@epri.com

Key Words for Internet Search:

Electroosmotic dewatering, electrodeewatering, biosolids, sludge.

Data Sources:

Electric Power Research Institute (EPRI). "Emerging Environmental Technologies: An Analysis of New Treatment Technologies for the California Energy Commission." Palo Alto, California. California Energy Commission, Sacramento, California. 1007411. (2003)

Technology Summary

Membrane Filter Press

Objective:

Increases percent of solids in biosolids cake.

State of Development: Embryonic

According to one vendor of membrane filter press technology, their press has been used in the following industries: chemical processing, pharmaceuticals, food product and ingredient manufacturers, wine and juice producers, industrial waste dewatering and recycling.

Description:

Membrane filter presses operate on what the manufacturer calls the "variable chamber principle." The liquid biosolids are pumped into a chamber. The clear filtered liquid passes through the filter cloth against a drainage surface built into the plate, just like on a conventional filter press. Once the filtration step has been completed, the flexible membrane, or diaphragm, is inflated with pressurized fluid, typically water, thereby compressing the formed filter cake. The final cake discharge volume is reduced in the process.

Comparison to Established Technologies:

Not comparable to established technologies.

Available Cost Information:

Approximate Capital Cost: Not available

Approximate O&M Costs: Not available

Vendor Name(s):

Komline-Sanderson Engineering Corp.
12 Holland Avenue
Peapack, NJ 07077
Phone: 800-225-5457
Fax : 908-234-9487
E-mail: info@komline.com

Practitioner(s):

No practitioner at this time.

Key Words for Internet Search:

Membrane filter press, biosolids sludge

Data Sources:

Vendor-supplied information

Technology Summary

Simon Moos	
<p>Objective: On-site dewatering for septic tanks and small wastewater treatment plants.</p>	<p>State of Development: Embryonic According to the manufacturer, the Simon Moos technology has been successfully demonstrated to pump and dewater septic tanks, grease traps, wastewater treatment plants, and various types of industrial sludge.</p>
<p>Description: The Simon Moos System consists of a dewatering container and a built-in or a separate pump and dosing plant. Dewatering of sludge is achieved by the injection of polymer into the sludge as it is being pumped by the sludge pump or pressed through the cyclone of the system's pump and dosing plant into the dewatering container. During this operation, polymer amounts are adjusted to achieve the best sludge flocculation possible. Once separated, the water flows through a special set of filter nets installed inside the container and out drain ports located on each side of the container. Solids remain inside the container until accumulation requires dumping and disposal.</p>	
<p>Comparison to Established Technologies: Not comparable to established technologies.</p>	
<p>Available Cost Information: <i>Approximate Capital Cost:</i> Not provided by vendor <i>Approximate Capital Cost:</i> Not provided by vendor</p>	
<p>Vendor Name(s): Simon Moos Maskinfabrik A/S Kallehave 33, Horup DK-6400 Sonderborg, Denmark Phone: +45 74 41 0 51 Fax : +45 74 41 52 08 E-mail: MW@simonmoos.com</p>	<p>Practitioner(s): Nykøbing Falster Wastewater Treatment Plant Denmark</p>
<p>Key Words for Internet Search: Simon Moos, mobile dewatering, biosolids, sludge.</p>	
<p>Data Sources: Vendor-supplied information</p>	

Technology Summary

Tubular Filter Press

Objective:

Dewater and thicken inorganic sludges.

State of Development: Embryonic

The tubular filter press has primarily been used for dewatering of mining waste waters. One pilot study showed that chromium discharge to the environment in mine wastewater could be nearly eliminated by concentrating the pollutants in the dried cake. The tubular filter press also has been used to treat drinking water in South Africa.

Description:

Sludge is pumped at a high velocity through a series of tube-shaped filter presses constructed of proprietary fabric. Cake from the tube walls is then dislodged by a roller cleaning and the cake, in the form of flakes, is simultaneously transported out of the tubes, drained, and conveyed to a collection hopper.

Comparison to Established Technologies:

Not comparable to established technologies.

Available Cost Information:

Approximate Capital Cost: Not available

Approximate O&M Costs: Not available

Vendor Name(s):

Explochem
P.O. Box 400
Ferndale, 2160, Gauteng, South Africa
Phone: +27 11 888-3926
Fax : +27 11 888-3942
E-mail: micheleb@explochem.co.za

Practitioner(s):

No practitioner at this time.

Key Words for Internet Search:

Tubular filter press, South African wastewater treatment, biosolids, sludge

Data Sources:

Coopman's, E.P.A., H.P. Schwarz, M.J. Pryor. "The dewatering of a mining sludge containing hexavalent chromium using a tubular filter press – a South African development." *Water Supply*. 1:5-6 (2001) 371-376.

Vendor-supplied information.

Technology Summary

Mechanical Freeze-Thaw

Objective:

Increase the dewaterability of sludge without chemical additives.

State of Development: Embryonic

Pilot-scale demonstrations of nonmechanical freeze/thaw drying beds have been successful in New York State. The mechanization of the process in order to speed up the freeze/thaw cycles is still being studied.

Description:

In freeze-thaw dewatering, the sludge is frozen using commercially available freezer equipment. The frozen sludge is crushed and allowed to thaw naturally. Freezing alters the chemical bonds between the solids in the sludge and the water, making the sludge more easily dewatered. The conditioned sludge is then processed using conventional sludge dewatering equipment. Conditioning the sludge increases the amount of water that can be removed from the sludge. Testing has shown this technology to be particularly successful with inorganic (e.g., alum and ferric iron) sludges.

Comparison to Established Technologies:

Similar to drying beds with refinements (addition of freezer equipment) which improves sludge dewatering.

Available Cost Information:

Approximate Capital Cost \$250,000 – \$1,500,000

Approximate O&M Costs: \$26,000 – \$960,000

The total installed cost of a freeze/thaw system is directly related to the amount of ice produced each day for use in the freezing process. Fewer freezer plates will reduce the installation cost. Properly maintained residuals freezing and refrigeration systems can be expected to provide many more years of service than the typical 10-year period assumed for economic evaluation. Frequently, annual maintenance costs are estimated as a percentage of total plant equipment cost, which has generally proven to be realistic and reasonable values. The above ranges of capital and O&M costs were estimated for residuals production ranging from 2,500 to 40,000 gallons per day. This process is typically more cost-effective in cooler climates where natural freezing may occur.

Vendor Name(s):

Not available

Practitioner(s):

The following tested the technology but is not a current practitioner.

Electric Power Research Institute

3420 Hillview Avenue

Palo Alto, CA 94304

Phone: 650-855-2000

Key Words for Internet Search:

Freeze-thaw dewatering, mechanical freeze-thaw, biosolids, sludge

Data Sources:

Energy Power Research Institute (EPRI). Mechanical Freeze/Thaw and Wastewater Residuals: Status Report. Palo Alto, California. TR-112063 (1998)

EPRI. Mechanical Freeze/Thaw and Freeze Concentration of Water and Wastewater Residuals: Status Report. Palo Alto, California. WO-671002. (2001)

Thermal Conversion

6.1 Introduction

Thermal conversion processes are used to significantly reduce volume by oxidizing the organic matter in the biosolids. Some treatment plants that use thermal conversion lower their energy costs by recovering energy as a part of these processes.

6.2 Technology Assessment

Table 6.1 summarizes the state of development of thermal conversion technologies.

In the past, thermal conversion of wastewater residuals has often been equated with incineration. However in recent years, some industries and municipalities have shown interest in creating a usable product, such as fuel from their thermal conversion processes. Four emerging thermal conversion technologies featured in this chapter—gasification, melting furnace, sludge-to-oil and supercritical water oxidation—aim to produce a usable end product. Both the reheat and oxidize (RHOX) process and oxygen-enhanced incineration have improved conventional incineration by making it more efficient and/or reducing air emissions. Molten salt oxidation has been used primarily for industrial applications where the wastewater residuals are hazardous, or in areas where biosolids must be destroyed.

Figure 6.1 includes an evaluation of the innovative technologies identified. A summary sheet for each innovative and embryonic technology is provided at the end of this chapter.

Table 6.1 – Thermal Conversion Technologies—State of Development

Established	Innovative	Embryonic
Combustion <ul style="list-style-type: none"> Fluidized-Bed Furnace Multiple-Hearth Furnace Oxidation <ul style="list-style-type: none"> Wet Air Oxidation 	Combustion <ul style="list-style-type: none"> Reheat and Oxidize (RHOX) Oxidation <ul style="list-style-type: none"> Supercritical Water Oxidation Vitrification <ul style="list-style-type: none"> Minergy 	Combustion <ul style="list-style-type: none"> Molten Salt Oxidation Oxygen-Enhanced Incineration Fuel Production <ul style="list-style-type: none"> Gasification Sludge-to-Oil SlurryCarb™ Oxidation <ul style="list-style-type: none"> Deep-Shaft Wet Air Oxidation (VERTAD™) Plasma Assisted Sludge Oxidation Vitrification <ul style="list-style-type: none"> Melting Furnace

Figure 6.1 – Evaluation of Innovative Thermal Conversion Technologies

Process	Evaluation Criteria										Comments
	Development	Applicability	Potential Benefits	Beneficial Use	Impact on Other Processes	Complexity	Air Emissions	Energy	Footprint	Environmental	
Reheat and Oxidize (RHOX)	I	I	O,V	N/A	⊖	⊖	▲	▲	⊖	▲	
Supercritical Water Oxidation	P,O	F	V,A	A	▲	▼	▲	▲	▲	▲	
Minergy	I	F	V,R	C	⊖	▼	⊖	▼	▼	▲	

Statement of Development B = Bench scale D = Full-scale demonstrations in North America I = Full-scale industrial applications, with demonstrations or pilots for municipal sewage sludge O = Full-scale operations overseas N = Full-scale operations in North America P = Pilot	Applicability F = Few plants I = Industrywide L = Primarily large plants S = Primarily small plants	Potential Benefits A = Produces Class A biosolids C = Capital savings O = Operational/maintenance savings F = Produces high-nutrient fertilizer M = Minimizes odors R = Provides beneficial use (nonagricultural) V = Sludge volume reduction	Beneficial Use A = Agriculture C = Construction N/A = Not Applicable P = Power Comparative Criteria ▲ Positive feature ⊖ Neutral or mixed ▼ Negative feature
--	--	---	--

Technology Summary

Reheat and Oxidize (RHOX)

Objective:

Decrease fuel usage and air emissions from biosolids incineration furnaces.

State of Development: Innovative

The first RHOX installation at a wastewater treatment plant used a shell and tube heat exchanger to preheat the scrubbed gasses on their way to the afterburner. This unit, located in Willow Grove, Pennsylvania, has operated for almost 10 years.

Description:

Hot (1,500°F) afterburned gases are passed down through a bed of ceramic forms. In doing so, the heat content of the gas is transferred to the ceramic mass and the gas is cooled (to about 250°F) for discharge to the atmosphere. Cold, dust-free gas from the afterburner pollution control equipment is passed up through another bed of ceramic forms, which has previously been heated with afterburner gas. Here, the cold gas is preheated to a temperature approaching the afterburner requirement by extracting the heat previously stored in the mass of ceramic forms. A small quantity of fuel is burned in the afterburner to reach the required temperature. The hot and cold gases pass back and forth through two or more beds to achieve preheating and cooling.

Comparison to Established Technologies:

Technology designed to reduce emissions. Not similar to any other established technology.

Available Cost Information:

Approximate Capital Cost: Not available

Approximate O&M Costs: Not available

Vendor Name(s):

Chavond-Barry Engineering Corporation
400 County Road 518, P.O. Box 205
Blawenburg, NJ 08504
Phone: 609-466-4900
Fax : 609-466-1231

Practitioner(s):

Upper Moreland Hatboro Joint Sewer Authority
2875 Terwood Road
Willow Grove, PA

Additional practitioners are available from the vendor.

Key Words for Internet Search:

RHOX process, sludge, biosolids, reheat, oxidize

Data Sources:

Vendor-supplied information

Technology Summary

Supercritical Water Oxidation

Objective:

Reduce the volume of biosolids using the physical properties of water.

State of Development: Innovative

Application of the process in industrial and wastewater treatment facilities is ongoing. The first two units were installed at the Harlingen, Texas, wastewater treatment facility in July 2001 for use in a pilot study.

Description:

Water is heated and pressurized above the critical point [374°C and 3,191 pounds per square inch (psi)] and the solubility of organic substances and oxygen into water is significantly increased. Supercritical water oxidation technology takes advantage of this characteristic to completely decompose organic substances. This technology produces a high-quality effluent and is capable of producing Class A biosolids. Supercritical water oxidation also may be referred to as "hydrothermal oxidation."

Comparison to Established Technologies:

Not similar to established technologies.

Available Cost Information:

Approximate Capital Cost: \$3,500,000

Approximate O&M Costs: \$160—\$295 per dry ton

Capital and O&M costs are for the system installed at the Harlingen Water Works System wastewater treatment facility in July 2001. O&M costs include seven major components: oxygen (55.3%), natural gas (12.5%), labor-operators (12.4%), electrical (8%), solids disposal (6%), maintenance (5%), and expendable chemicals (0.5%).

Vendor Name(s):

HydroProcessing LLC
3201 Longhorn Blvd., Suite 101
Austin, TX 78758
Phone: 512-339-9981
E-mail: info@hydroprocessing.com

Practitioner(s):

The following was the site of a demonstration facility but is not currently a practitioner:
Harlingen Water Works System
134 East Van Buren
Harlingen, TX 78550
Phone: 956-430-6100
Fax: 956-430-6111
www.hwws.com

Key Words for Internet Search:

Supercritical water oxidation, SCWO, biosolids, sludge

Data Sources:

Bartholomew, R. *Conversion of Biosolids: An Innovative Alternative to Sludge Disposal*. Pennsylvania Department of Environmental Protection. (October 2002).

Kelly, H.G. *Emerging Technologies in Biosolids Treatment*. Dayton & Knight Ltd., West Vancouver, Canada. (2003)

Technology Summary

Minergy

Objective:

Convert biosolids into construction material and industrial feed stocks that are inert and marketable.

State of Development: Innovative

Minergy's GlassPack® Demonstration Unit in Winneconne, Wisconsin, built in 2000, is a 12-dry-tons-per-day commercial-scale system available to demonstrate Minergy's GlassPack® technology. Solids from several wastewater treatment plants have been processed at the facility on trial bases. There are operational systems using pulp and papermill sludges.

Description:

Minergy gives the following description of the three-zone operation of the GlassPack vitrification system:

Zone 1 Melting and Combustion. Feedstock that has been predried to approximately 90% solids or more is injected along with air or synthetic air into the Zone 1 chamber. In this zone, the organic component of the sludge is completely combusted, liberating a significant amount of heat energy. In a closed-loop oxygen-enhanced application, this energy release results in temperatures of approximately 2,400° to 2,700°F. At these high temperatures, the mineral (ash) component of the feedstock melts to form a pool of molten glass at the bottom of the Zone 1 chamber. The high-temperature environment provides very high destruction efficiencies of any organic compounds that may be contained in the feedstock.

Zone 2 Phase Separation. Phase separation of the molten glass and exhaust gas occurs by gravity draining the molten glass from Zone 1 through a drain port on the bottom of the Zone 2 chamber. The molten material drops into a quench tank and is cooled into the glass aggregate product. The exhaust gas is directed out of Zone 2 through a refractory-lined duct into Zone 3.

Zone 3 Gas Cooling. The exhaust gas from Zone 2 is 2,400°F to 2,700°F and is cooled through dilution mixing with lower temperature gases obtained external to the melter. Reducing the temperature offers two important cost-saving advantages. This system can eliminate refractory-lined ductwork exterior to the melter and can cool carry over particulate below its softening point, thus eliminating ductwork fouling. The temperature of the Zone 3 exit gas is dependent on the selection of heat recovery technology, but is typically in the range of 700° to 1,400°F. Higher exit gas temperature can provide for higher efficiencies in heat recovery systems.

Comparison to Established Technologies:

Similar to the Melting Furnace, an innovative technology. Minergy claims the GlassPack® process eliminates the need to co-fire fuel to achieve vitrification and provides significant environmental air emissions improvement over current combustion technologies due to the closed-loop design. In contrast to traditional incineration-type techniques, ash disposal is not necessary because the final end product is a glass aggregate that has many uses including sandblasting grit, roofing shingle granules, and asphalt paving.

Available Cost Information:

Approximate Capital Cost: \$104,000

Approximate O&M Costs: \$97,000

Cost estimates are for 7.5-ton-per-day glassification unit coupled to a thermal dryer with a minimum size of 20 dry tons per day. Estimates are from a cost analysis performed for Eastern Municipal Water District, California, and assume a 20-year life cycle and the costs associated with providing adequate facilities for this time period.

Vendor Name(s):

Minergy Corporation
1512 S. Commercial Street
Neenah, WI 54956
Phone: (920) 727-1919
E-mail: info@minergy.com
www.minergy.com

Practitioner(s):

Minergy Corporation Vitrification Technology Center
200 Tower Road
Winneconne, WI 54986

Minergy Corp. Fox Valley Glass Aggregate Plant
231 Millview Drive
Neenah, WI 54956

Technology Summary

Minergy (Contd)

Key Words for Internet Search:

Vitrification, Minergy, glassification, GlassPack®, biosolids, sludge

Data Sources:

Baudhuin, T, T. Carroll, and R. Paulson. 2005. Vitrification: A Sustainable Biosolids Management Alternative. Proceedings of the WEFTEC: The Water Quality Event, Washington, D.C.

(30 October – 2 November 2005) 659-666.

Kilian, R.E., A.C. Todd, A.K. Wason, M. Luker, J. Jannoni, J.D. Wall. (2003). "How to Put One Egg in Multiple Baskets." EMWD's Regional Biosolids Management Approach Makes Sense. Proceedings of the WEF/AWWA/CWEA Joint Residuals and Biosolids Management Conference, Baltimore, Maryland, USA. (19-22 February 2003).

Vendor website

Technology Summary

Molten Salt Incineration	
Objective: Eliminate or reduce biosolids volume.	State of Development: Embryonic This treatment system is favored for wastes contaminated with both chlorinated organics and heavy metals such as cadmium, chromium, zinc, etc. Industrial applications of this technology have been in use on a small scale since the 1950s.
Description: The Molten Salt Oxidation (MSO) process uses a sparged liquid bed of alkaline salt contained in a reaction vessel. The process is based on the catalytic action of alkaline molten salts for the oxidation of organic materials. The molten salt bed acts as a heat transfer and reaction media. Sufficient heat is liberated by the oxidation reaction to maintain the molten salt bed at a temperature of 900° to 1,000°C.	
Comparison to Established Technologies: Not similar to established technologies.	
Available Cost Information: <i>Approximate Capital Cost:</i> Not available <i>Approximate O&M Costs:</i> \$1,150/metric ton treated (Australian dollars) Generally, the cost of treatment with this technology is relatively high because of the high capital cost of the equipment, the labor requirements, and the high energy cost. The cost per ton depends on the feed rate of the contaminant to the furnace. The above O&M cost estimate was provided for hazardous waste sludges at a feed rate of 1,000 kilograms per hour, and it does not include effluent treatment costs, residuals and waste shipping costs, handling and transport costs, analytical costs, and site restoration costs.	
Vendor Name(s): None identified	Practitioner(s): No practitioner at this time.
Key Words for Internet Search: Molten salt oxidation, sludge	
Data Sources: CMPS&F Environmental. <i>Appropriate Technologies for the Treatment of Scheduled Wastes</i> . Review Report Number 4. (November 1997)	

Technology Summary

Oxygen-Enhanced Incineration

Objective:

Improve the performance of biosolids and industrial sludge furnaces.

State of Development: Embryonic

Praxair, Inc., claims successful operations in both municipal and industrial incineration applications with its Oxygen Combustion System (OCS).

Description:

A small amount of oxygen is added through an annulus around the fuel tube of the furnace to promote flame stability and consistent destruction efficiency during variations in feed material. Typical temperatures with air combustion are about 3,000°F (1,649°C), whereas temperatures with conventional oxygen-enriched systems can rise to 5,000°F (2,760°C), thereby reducing incomplete combustion.

Comparison to Established Technologies:

Reaches higher temperatures than conventional oxygen-enriched furnaces.

Available Cost Information:

Approximate Capital Cost: Not provided by vendor.

Approximate O&M Costs: Not provided by vendor.

Vendor Name(s):

Praxair, Inc.
39 Old Ridgebury Road
Danbury, CT 06810
Phone: 716-879-4077
Fax : 716-879-2040
www.praxair.com

Practitioner(s):

No practitioner at this time.

Key Words for Internet Search:

Praxair, oxygen-enhanced incineration, oxygen injection, biosolids, sludge.

Data Sources:

Vendor-supplied information.

Technology Summary

Gasification

Objective:

Reduce the volume of biosolids and produce gas that can be used to generate electricity.

State of Development: Embryonic

Recovery of biomass-derived gas for use as a fuel source has been used for industrial, wood and agricultural wastes in the United States for more than 50 years. It was used for production of coal gas for over 200 years. However, gasification of biosolids is a new application and there are no full-scale facilities operating in the United States. Industrial sludges have been successfully gasified at facilities in the United States. In 2002, the Balingen Sewage Works, Germany, started operation of a sewage sludge gasification plant as a demonstration study. Since 2004, it has been operating as a full-scale facility.

Waste to Energy Limited (United Kingdom) has patented a gasification system for the production of electricity. The company conducted a demonstration project with Anglian Water in the United Kingdom, and reports having an agreement with Kwikpower International to build biosolids gasification plants in Morocco.

Description:

The gasification process converts sludge or biosolids into a combustible gas, referred to as synthesis gas, or "syngas," which can be recovered. While incineration fully converts the input waste into energy and ash, gasification heats the material under controlled conditions, deliberately limiting the conversion so that combustion does not take place directly. Syngas can be used as a fuel to generate electricity and heat. The fuel value of Syngas is not typically as high as that of digester gas, perhaps 60% of digester gas energy values.

The gasification process takes place in two steps: pyrolysis and partial combustion. Pyrolysis is the degradation of biosolids in the absence of air, into a gas and a black, carbon-rich substance called "char." In the second reaction, the char is gasified by partial combustion in the presence of oxygen or air to produce the syngas described above. Due to the concentrating effect of the constituents in the original biosolids, the remaining char will require disposal, probably in a landfill.

Comparison to Established Technologies:

Similar to pyrolysis of other organic substances such as coal gasification.

Available Cost Information:

Approximate Capital Cost: Not provided by the vendor

Approximate O&M Costs: Not provided by the vendor

Studies have shown that gasification is technically feasible, but project costs are typically higher than conventional alternatives and not based on any full-scale operations. Data on true capital cost and operating costs for "real-world" applications are unavailable. Vendor-supplied literature suggests one kilogram of waste will typically produce one kilowatt of electricity and two kilowatts of heat. At this time, no full scale facilities are operating in the United States to verify these claims in actual operations.

Technology Summary

Gasification (Contd)

Vendor Name(s):

Waste to Energy Limited
Borley Green
Sudbury, England CO10 7AH
Phone: +44 1787 373007
Fax : +44 1787 373535
E-mail: info@waste-to-energy.co.uk
www.wastetoenergy.co.uk

Practitioner(s):

Anglian Water
P.O. Box 770
Lincoln, England LN5 7WX
Phone: +44 1522 341922
www.anglianwater.co.uk

US Centrifuge

4011 Championship Drive
Indianapolis, IN 46268
Phone: 800-899-2040
www.uscentrifuge.com

Kopf AG

Stützenstrasse 6
72172 Sulz-Bergfelden
Germany
www.kopf-ag.de
info@kopf-ag.de

Key Words for Internet Search:

Sewage sludge, gasification, waste-to-energy, bioenergy.

Data Sources:

KMK Consultants Limited. *City of Toronto Biosolids and Residuals Master Plan*. In association with Black & Veatch Canada. (September 2004).

Gasification Technologies Council website. www.gasification.org

Water Environment Federation, *Bioenergy from Wastewater Treatment – A Clean, Affordable Energy Source*. Alexandria, VA (2006).

Vendor-supplied information

Technology Summary

Sludge-to-Oil	
<p>Objective: Produce a commercially marketable oil product from biosolids.</p>	<p>State of Development: Embryonic</p> <p>ThermoEnergy Corporation, in conjunction with another contractor, operated a 5-MGD sludge-to-oil demonstration project in Colton, California, for two years. The project closed in November 2000 and the vendor is focusing on other technologies.</p> <p>Enersludge™ process was built at the Subiaco WWTP, Perth, Australia, in 1999. It operated for 4 months before being shut down when the oil product was deemed unsuitable for diesel engines.</p>
<p>Description: This technology uses an enhanced pyrolysis process that through specified pressures and catalysts can produce lightweight oils of varying viscosities.</p> <p>One such process is the ThermoFuel process marketed by ThermoEnergy Corporation in Little Rock, Arkansas. The company claims ThermoFuel allows wastewater treatment plant operators to meet all water quality standards, produce a product that meets Class A biosolids standards, and improve process efficiency at a lower cost without increasing the size of the plant.</p>	
<p>Comparison to Established Technologies: Not similar to established technologies.</p>	
<p>Available Cost Information: <i>Approximate Capital Cost:</i> \$3,000,000 <i>Approximate O&M Costs:</i> Not available Capital cost estimate is based on the approximate cost of the 5-MGD Colton, California, demonstration project described above.</p>	
<p>Vendor Name(s): ThermoEnergy Corporation 323 Center Street, Suite 1300 Little Rock, AR 72201 Phone: 501-376-6477 E-mail: technology@thermoenergy.com</p>	<p>Practitioner(s): No practitioner at this time.</p>
<p>Key Words for Internet Search: Sludge-to-oil, biosolids-to-oil, ThermoEnergy, ThermoFuel</p>	
<p>Data Sources: Kelly, H.G. <i>Emerging Technologies in Biosolids Treatment</i>. Dayton & Knight Ltd., West Vancouver, Canada. (2003) Vendor-supplied information.</p>	

Technology Summary

SlurryCarb™ Process

Objective:

Convert biosolids into a renewable fuel. For a dried product, a drying process must be added.

State of Development: Embryonic

Construction is scheduled to start in 2006 on a 675 wet tons per day facility in Rialto, California, that will incorporate the SlurryCarb™ process plus biosolids drying. The dried product from the facility, scheduled to begin full-scale operations in 2008, is intended to be used as fuel by a cement kiln. It is estimated that the facility will produce 140 dry tons of product per day.

Description:

Cake of between 20 and 30% solids are first macerated to create a feedstock of particles of less than ½ inch. The macerated solids are pressurized to above the saturated steam pressure, heated to approximately 450°F (232°C) and then fed to a reactor where temperature and pressure are maintained. The elevated pressure and temperature cause the cells to rupture and release carbon dioxide gas. This “carbonization” step causes the solids to lose their affinity for water. Following this carbonization step, the material is put through a centrifuge to separate off the liquid filtrate. Trace contaminants are removed from the filtrate and the purified water is recycled to the slurry preparation phase of the process or discharged. The carbonized material can then be dewatered to greater than 50% solids. The dewatered product can either be managed directly as slurry or further dried. The vendor reports plans to use the final product as a fuel supplement in operations such as cement manufacturing and pulverized coal boilers.

Comparison to Established Technologies:

The SlurryCarb™ process operates at a lower temperature and pressure, and for a shorter reaction time, than pyrolysis. It produces an energy-rich carbon product, but no gases or oils like pyrolysis. The SlurryCarb™ process also operates at a lower temperature and pressure, and for a shorter reaction time than typical wet air oxidation, and no air is added to partially oxidize the organics in the biosolids. SlurryCarb™ also differs from the Carver-Greenfield® process in that the SlurryCarb™ process does not add anything to the biosolids and does not evaporate water. However, if a dried product is necessary, evaporative drying would have to be added. Drying will probably be required due to very limited use for a 50% solids slurry.

Available Cost Information:

Approximate Capital Cost: Not provided by the vendor

Approximate O&M Costs: Not provided by the vendor

Vendor Name(s):

EnerTech Environmental, Inc.
675 Seminole Ave., Suite 207

Atlanta, GA 30307

Phone: 404-355-3390

Fax: 404-355-3292

Email: slurrycarb@enertech.com

Website: www.enertech.com

Practitioner(s):

City of Rialto

Public Works Department

335 W. Rialto Avenue

Rialto, CA 92376

Phone: 909-820-2608

Email: publicworks@rialtoca.gov

Technology Summary

SlurryCarb™ Process (Contd)

Key Words for Internet Search:

SlurryCarb™, biosolids, sludge, carbonization, renewable fuel

Data Sources:

EnerTech Environmental, Inc. Company Information Packet: The SlurryCarb™ Process. (2006) Available at www.enertech.com.

EnerTech Environmental, Inc. "Converting Biosolids to a Usable Fuel: The Emerging Technology of Biosolids Carbonization –The Rialto Regional Biosolids Facility." Presentation to CIWMB, (12 May 2005).

Kearney, R.J. and K.M. Bolin. "Using the New SlurryCarb™ Process Prior to Drying: How to Save Money and Achieve Permanent Recycling of Biosolids." Proceedings of the WEF/AWWA Joint Residuals and Biosolids Management Conference, Cincinnati, Ohio. (12–15 March 2006).

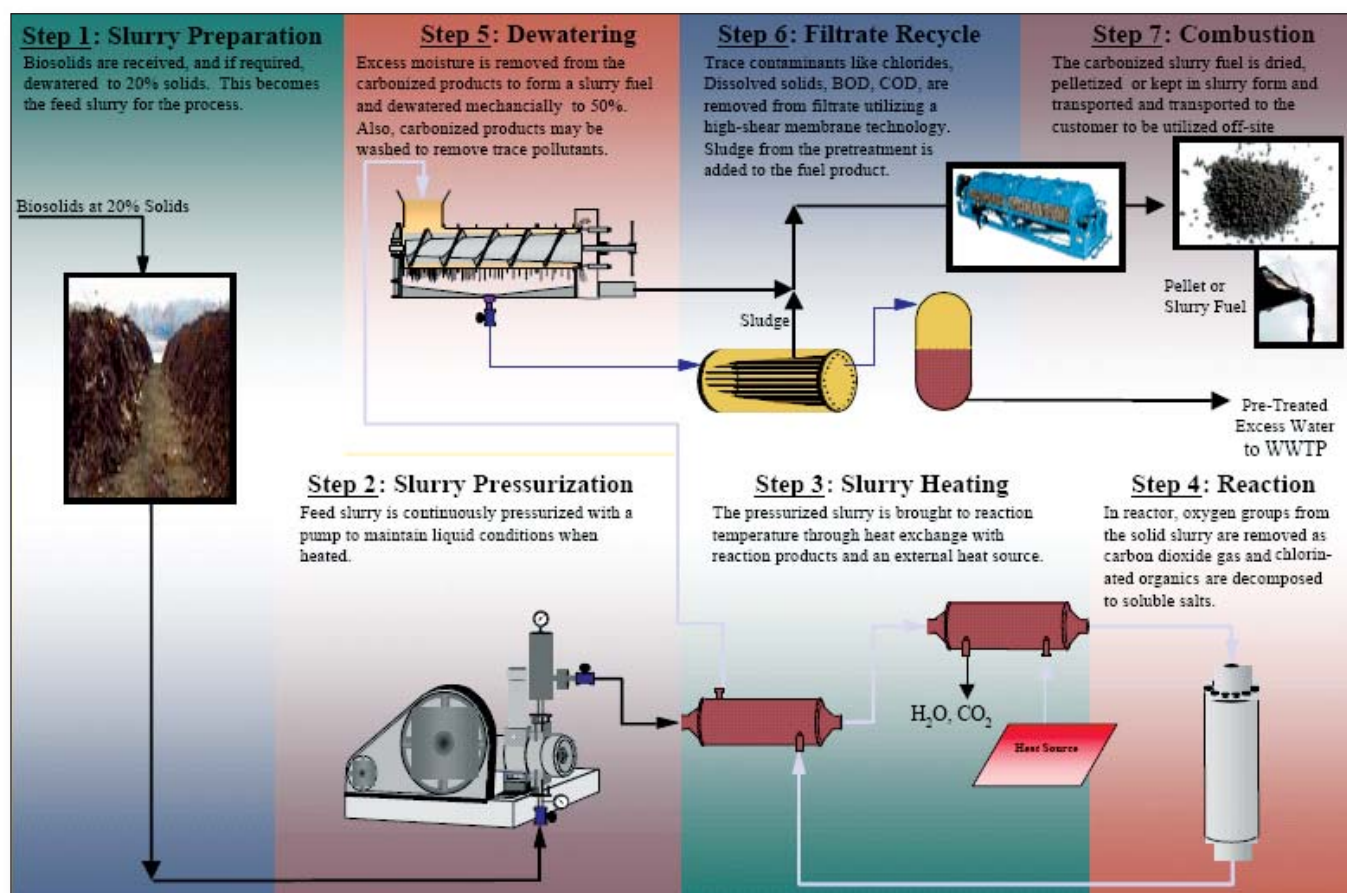

SlurryCarb™ process flow diagram from EnerTech Environmental, Inc. (2005)

Technology Summary

Deep-Shaft Wet Air Oxidation (VERTAD™)

Objective: Increases energy efficiency and produces Class A biosolids.	State of Development: Embryonic The last trial of this technology related to biosolids was at King County's Renton Wastewater Treatment Plant, Washington.
--	--

Description:
 Deep-Shaft Wet Air Oxidation is an autothermophilic aerobic digestion process that treats sludge in a subsurface autothermophilic reactor that is 250–350 feet deep. The VERTAD™ vendor's website describes three reactor zones that function as follows:

Oxidation Zone: The top of the shaft where the sludge digestion takes place.

Mixing Zone: Feed sludge and air are introduced in this zone. Air provides oxygen and mixing. Solids separation is through flotation thickening.

Saturation Zone: Stabilized biosolids removed from the reactor flow through the saturation zone where high temperature and long residence time occur.”

High oxygen transfer efficiency promotes rapid digestion of sludge. Pathogen-free Class A biosolids are produced in four days. Thickened biosolids can be dewatered to 30%–35% solids and reduced polymer usage. Offgas is separated and treated in a fixed-film biofilter.

Comparison to Established Technologies:
 Similar to vertical reactors that have been used for wastewater treatment for 25 years. VERTAD™ has a small footprint and is largely underground. Therefore they are less visible than surface tankage.
 VERTAD™ achieves 40% volatile solids (VS) reduction in 4 days in comparison to conventional anaerobic digestion systems that require up to 30-day retention times for a 55% VS reduction.

Available Cost Information:

Approximate Capital Cost: Capital cost lower than conventional autothermal thermophilic aerobic digestion (ATAD) plant of similar size.

Approximate O&M Costs: Not Available

Low energy requirements: 1.27 kW.hr/kg VS destroyed

Low polymer requirements: 14 lb/ton

Vendor Name(s): NORAM Engineering and Construction, LTD Suite 400-200 Granville Street Vancouver BC V6C 1S4 Phone: 604-681-2030 Fax: 604-683-9164 www.noram-eng.com	Practitioner(s): The following was the site of a trial facility but is not currently a practitioner: Technology Assessment and Resource Recovery King County 201 South Jackson Street Mail Stop: KSC-NR-0512 Seattle, WA 98104 Phone: (206) 684-1255 Fax: (206) 684-2057
---	---

Technology Summary

Deep-Shaft Wet Air Oxidation (VERTAD™) (Contd)

Key Words for Internet Search:
 VERTAD™, deep-shaft, wet air oxidation, biosolids

Data Sources:
 Vendor-supplied information.

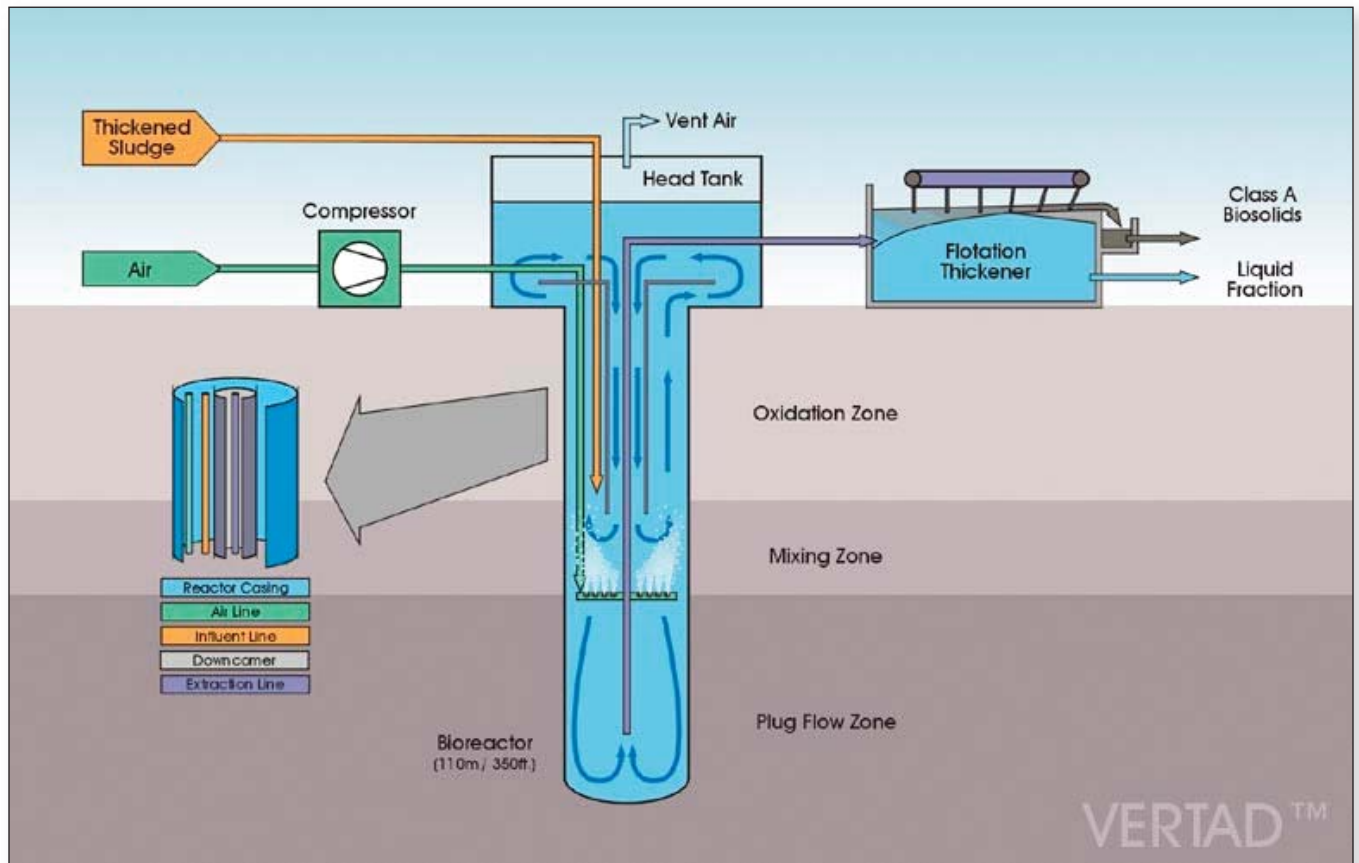

Flow diagram of typical VERTAD™ installation (courtesy of NORAM Engineering)

Technology Summary

Plasma Assisted Sludge Oxidation

Objective:

Significant volume reduction through combustion.

State of Development: Embryonic

The process was pilot tested by LTEE, Hydro-Quebec's research facility, for approximately 2 years using industrial, municipal, and farming feedstocks.

Description:

Plasma assisted sludge oxidation uses a rotary oven operating at between 600° and 700°C at atmospheric pressure. The oven is equipped with an air plasma arc torch. The plasma arc generates ultraviolet radiation and ionic radicals to sustain oxidation. A plasma plume is used to catalyze oxidation of wet sludges at relatively low temperatures. The vendor claims low operating temperatures result in high combustion efficiency. Feed solids can have a solids content as low as 20% but operating efficiencies are directly related to the solids content. The process results in an ash to be used or disposed. Combustion can reach autothermal operation if feed solids have a high enough energy value [estimated at 20,000 millijoules per dry ton (mJ/dry ton)].

Comparison to Established Technologies:

Not similar to established technologies.

Available Cost Information:

Approximate Capital Cost: Not available

Approximate O&M Costs: Not available

Vendor Name(s):

Fabgroups Technologies, Inc.
1100 St. Amour
St. Laurent, Quebec, Canada H4S 1J2
Phone: 514-331-3712
Fax: 514-331-5656
Email: tmulhern@fabgroups.com

Practitioner(s):

No practitioner at this time.

Key Words for Internet Search:

Plasma assisted oxidation, biosolids, sludge

Data Sources:

Mulhern, T. and M. Bacon. "Full Scale Demonstration of Plasma Assisted Sludge Oxidation." *Proceedings of the 2006 WEF Residuals and Biosolids Management Conference*, Cincinnati, Ohio. (12–15 March 2006).

Technology Summary

Melting Furnace

Objective:

Reduce the volume of biosolids and industrial wastes by heating them to extremely high temperatures while producing potentially usable by-products.

State of Development: Embryonic

Full-scale melting furnaces have been in operation in Japan for more than 20 years. This is primarily due to the lack of available space for land application or surface disposal of municipal biosolids. Similar melting furnaces have been used to melt industrial sludges as well. As of 2003, the Ebara Corporation was operating two small plants using the Meltox technology that had been in operation for nearly 4 years. In addition, the Ministry of Housing and Local Government in Malaysia decided in 2003 to construct a large TwinRec thermal waste treatment plant for municipal waste.

Description:

The Ebara Corporation of Japan has developed the Meltox (called TwinRec in Europe) biosolids melting and ash incineration technology. This process melts biosolids at temperatures exceeding 1,300°C and produces a marketable by-product. The furnace is fluidized bed gasification unit comprising a vertical primary combustion chamber, an inclined secondary combustion chamber, and a slag outlet section. Biosolids are blown into the furnace with compressed air, where they are incinerated and melted during a spiral descent. A plate at the outlet maintains a steady flow of slag, which is cooled by water or air before discharge. Flue gas is separated and treated to reduce odors and sulfur oxide (SO_x) emissions. The slag can be used in various ways, such as for filling material, tiles for pavement and roads, interlocking blocks, terrazzo tiles, and other construction materials.

Comparison to Established Technologies:

Similar to fluidized bed furnace except that it can operate at higher temperatures. Similar to innovative vitrification furnace.

Available Cost Information:

Approximate Capital Cost: Not available

Approximate O&M Costs: Not available

Vendor Name(s):

Ebara Corporation
1-6-27, Konan, Minato-ku
Tokyo, 108-8480 Japan
Phone: +81-3-5461-5585
Fax : +81-3-5461-5784
Website: www.ebara.ch

Practitioner(s):

A list of practitioners using Ebara Corporation melting furnace technologies in Asia is available online at:
www.ebara.ch/twinrec.php?n=1

Key Words for Internet Search:

Melting furnace, biosolids, sludge, Meltox

Data Sources:

Selinger, A., S. Steiner, K. Shin. "TwinRec Gasification and Ash Melting Technology – Now also established for Municipal Waste." *4th Int'l Symposium on Waste Treatment Technologies*. Ebara Corporation, Zurich. (2003)

Japanese Advanced Environment Equipment. Meltox Sludge Melting System. Global Environment Centre Environmental Technology Database NETT21. (2002)

Vendor-supplied information.

Drying

7.1 Introduction

The objective of the drying process is to remove water from biosolids producing a relatively high percent solids, and to reduce weight and volume of the biosolids. This is usually accomplished with either a direct or indirect heat source. Drying can produce marketable products that meet Class A standards. It also dramatically reduces transportation costs if long distance hauling is involved.

7.2 Technology Assessment

Table 7.1 summarizes the state of development of drying technologies. This table includes three innovative heat-drying technologies. Belt, flash, and microwave drying all have been successfully operated in Europe and pilot-tested in the United States.

Figure 7.1 includes an evaluation of the innovative technologies identified. Summary sheets for each technology categorized as innovative or embryonic technology are provided at the end of this chapter.

Table 7.1 – Drying Technologies—State of Development

Established	Innovative	Embryonic
Direct Drying Flash Drying Indirect Drying	Belt Drying Direct Microwave Drying Flash Drying Fluidized Bed Drying	Chemical Drying Multiple Effect Drying <ul style="list-style-type: none"> ▪ Carver-Greenfield (case studies have shown technology to be not viable in the United States. No technology summary is provided.)

Figure 7.1 – Evaluation of Innovative Drying Technologies

Process	Evaluation Criteria										Comments
	Development	Applicability	Potential Benefits	Beneficial Use	Impact on Other Processes	Complexity	Air Emissions	Energy	Footprint	Environmental	
Belt Drying	O	S	C,O,V,A,R	A,P	⊖	⊖	▼	▲	▲	▲	
Direct Microwave Drying	D	I	C,O,V,A,R	A,P	▼	⊖	⊖	▲	▲	⊖	
Flash Drying	B,P	S	C,O,V,A,R	A,P	▲	⊖	⊖	⊖	⊖	⊖	Centrifuge and drying process in one.
Fluidized Bed Drying	O	I	C,O,V,A,R	A,P	▲	⊖	▲	⊖	⊖	⊖	

<p>Statement of Development</p> <p>B = Bench scale D = Full-scale demonstrations in North America I = Full-scale industrial applications, with demonstrations or pilots for municipal sewage sludge O = Full-scale operations overseas N = Full-scale operations in North America P = Pilot</p>	<p>Applicability</p> <p>F = Few plants I = Industrywide L = Primarily large plants S = Primarily small plants</p>	<p>Potential Benefits</p> <p>A = Produces Class A biosolids C = Capital savings O = Operational/maintenance savings F = Produces high-nutrient fertilizer M = Minimizes odors R = Provides beneficial use (nonagricultural) V = Sludge volume reduction</p>	<p>Beneficial Use</p> <p>A = Agriculture C = Construction N/A = Not Applicable P = Power</p>
<p>Comparative Criteria</p> <p>▲ Positive feature ⊖ Neutral or mixed ▼ Negative feature</p>			

Technology Summary

Belt Drying

Objective:

Drying of biosolids to 90% or more solids.

State of Development: Innovative

A BioCon® dryer has been in operation at the Bronderslev WWTP in Denmark since 1995. The first operating US facility will be Mystic Lake, Minnesota.

A HUBER KULT® dryer for wastewater sludge is under construction in Germany. There is also a HUBER KULT® dryer in operation in Germany for drying water treatment plant residuals.

Description:

This technology is composed of two or more slow moving belts in series with air supplied through or around the belts. Dewatered sludge is spread in a thin layer on the first belt to maximize surface area. Preheated air is either blown through the belts or pumped into the area surrounding the belts.

In the BioCon® dryer, temperatures ranges from 350°F at its hottest down to 175°F as the biosolids complete the drying process. The residence time in the dryer is more than 60 minutes, thereby exceeding Class A pathogen reduction requirements. An add-on process called the Energy Recover System (ERS), uses the fuel value of the dried product to generate energy used in the drying process.

Comparison to Established Technologies:

The BioCon® dryer is operated at a low negative pressure to minimize odor and dust generation often associated with biosolids drying technologies.

Available Cost Information:

Approximate Capital Cost: Not provided by the vendor.

Approximate O&M Costs: Not provided by the vendor.

Vendor Name(s):

Kruger, Inc.
401 Harrison Oaks Blvd., Suite 100
Cary, NC 27513
Phone: 919-677-8310
Fax: 919-677-0082

Practitioner(s):

Mystic Lake, Minnesota

Huber Technology
9805 North Cross Center Court
Suite H
Huntersville, NC 28078
Phone: 704-949-101
Website: www.huber-technology.com

Technology Summary

Belt Drying (Contd)

Key Words for Internet Search:
 BioCon, ERS, Huber Technology KULT®, biosolids, sludge, drying

Data Sources:
 Frewerd, B. "Harnessing the Power of Biosolids." Published by Kruger Inc., a division of Paris-based Veolia Water Solutions & Technologies. (2006).
 Vendor websites.

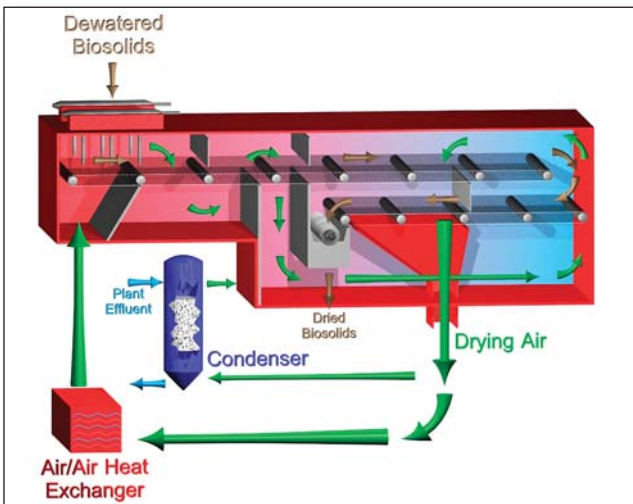

BioCon® Process Flow Diagram (Frewerd, 2006).



BioCon® ERS Unit
 (Photo courtesy of Kruger USA).

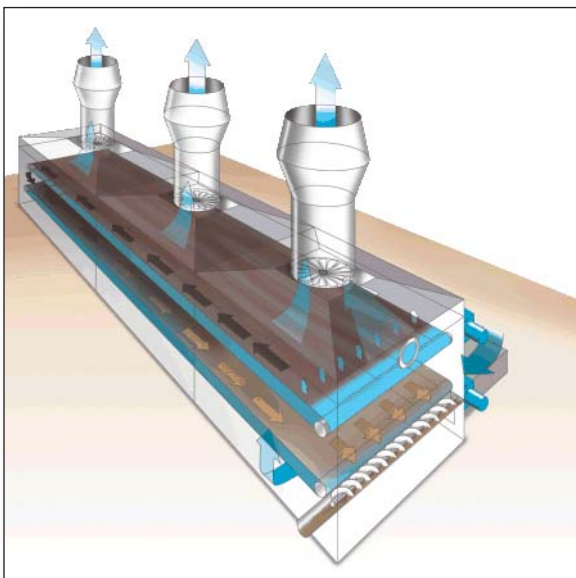

KULT® dryer schematic
 (Huber Technology website 8 August 2006).

Technology Summary

Direct Microwave Drying

Objective:

Remove excess water from waste activated sludge and reduce pathogens.

State of Development: Innovative

Burch BioWave® is in use in Ireland and Fredericktown, Ohio. A new installation will be on line in Zanesville, Ohio, in fall 2006.

Description:

Burch BioWave® is a patented continuous flow process that uses a dual-fueled microwave system to remove water and pathogens from dewatered sludge. The process utilizes a high-efficiency multi-mode microwave system specifically designed to remove moisture. Microwaves vibrate water molecules and the resulting friction heats the water. BioWave® uses heated air forced through the biosolids to evaporate the moisture released by the microwaves. The air is heated by either natural gas, liquified petroleum gas (LPG), or digester gas.

The equipment comes in various sizes, each with the ability to dry a certain throughput of material. The process is completely automated and can dry biosolids with an initial moisture content of 85% to a final product with 10% moisture content. Tests show 100% pathogen kill without any change in nutrient content.

Comparison to Established Technologies:

Established drying technologies use natural gas as fuel and rely on convection to heat solids from the outside in along with a loss of energy to the environment. In microwave drying, all the materials are heated simultaneously and the heat is generated from within the material.

Available Cost Information:

Approximate Capital Cost: \$800,000 for system capable of processing 1 dry ton per day

Approximate O&M Costs: Not provided by the vendor.

Equipment provided in cost includes stainless steel applicator unit, four 100-kilowatt microwave transmitters, control panel, 250,000-BTU gas burner, standard aluminum wave guides, operator training and 1-year system warranty.

Maintenance cost are low because there are no moving parts. Electricity is more than 90% of the energy used. System is 80% energy efficient.

Vendor Name(s):

Burch Hydro, Inc.
17860 Ankneytown Road
Fredricktown, OH 43019
Phone: 800-548-8694

Website:

www.burchbiowave.com/sections/process/index.asp

Practitioner(s):

Fredericktown, Ohio.

Technology Summary

Direct Microwave Drying (Contd)

Key Words for Internet Search:

Burch BioWave[®], microwave dryer, biosolids

Data Sources:

Vendor-supplied information.



Burch BioWave[®] dryer installed

Technology Summary

Flash Drying

Objective:

Drying of biosolids to 90% or more solids.

State of Development: Innovative

The Centridry® flash drying process was evaluated in King County, Washington, where it reduced the water content of 20% dewatered solids to 60%–70% solids. However, product testing indicated that for best usability, the product should also be composted, which significantly increases costs. This project was completed in the summer of 2001 and King County does not anticipate any further testing on this process. Centridry® units have been in operation in Europe since 1993.

Description:

Liquid biosolids combined with polymer are pumped into a centrifuge where conventional mechanical dewatering takes place. The dewatered biosolids reach a minimum of 25% dry solids, and are discharged into the thermal stage as a fine-grained spray.

The biosolids particles are instantly dried upon entering the thermal cyclone chamber in order to prevent them from sticking to the walls of the chamber. The particles are then entrained and conveyed in the sweep gas, and exit the chamber in a matter of seconds during which time the sludge granules are dried and the temperature of the conveying gas is dramatically reduced. The pneumatic conveying and drying process continues during the relatively short transport time to a cyclone where the product particles are separated and discharged via a rotary valve to the stockpile.

The sweep gas, drawn through the system via the main ventilator fan, is reheated in the hot gas generator before re-entering the dryer loop. Excess gas vapors in the system are drawn off by a small blower, treated in a venturi scrubber to remove residual quantities of fine dust and volatile components, and discharged for odor treatment.

Comparison to Established Technologies:

Similar to other drying processes; however CentriDry® does not require biosolids to be dewatered prior to entering the unit.

Available Cost Information:

Approximate Capital Cost: Not provided by the vendor.

Approximate O&M Costs: Not provided by the vendor.

Vendor Name(s):

Euroby Limited
Columbia House, Columbia Drive
Worthing, West Sussex BN13 3HD
Phone: +01-903-69-44-00
E-mail: sales@euroby.com
Website: www.euroby.com/centridy.htm

Practitioner(s):

Severn Trent Water STW
Worksop, UK

Key Words for Internet Search:

Centridry®, centrifuge drying, biosolids, sludge

Data Sources:

King County Department of Natural Resources. Regional Wastewater Services Plan – Annual Report. Wastewater Treatment Division. (December 2001).

Vendor-supplied information

Technology Summary

Fluidized Bed Drying

Objective:

Provide a safer, more reliable, more flexible technology for drying digested/undigested municipal biosolids to Class A levels.

State of Development: Innovative

Three plants in Europe are currently operating using this technology. It is used in other industrial applications in the U.S.

Description:

Mechanically dewatered wet cake is pumped from storage directly into the fluidized bed dryer, where it comes in contact with already-dry granules, building larger granules. The process is done entirely within the fluid bed itself without the need for recycling/blending/classifying steps. It is also accomplished within an inert closed loop. Only a minimal amount of gas is exhausted for treatment. All heating is done via indirect means with heat exchanger surfaces (tubes) immersed in the fluidized layer of solids in the dryer. Heating configuration is extremely flexible and can be accomplished with energy derived from natural gas, digester gas, steam, waste heat, and other sources. The end product is $\geq 90\%$ dry solids, dust free, mechanically stable, and can be used in land application or as a fuel and mineral source in cement kilns.

Comparison to Established Technologies:

Not similar to any established biosolids management technologies. This process is established for drying pellets, powders, and granules in the chemical and pharmaceutical industries.

Available Cost Information:

Approximate Capital Cost: Approximately \$750,000 per ton of water per day evaporated.

Approximate O&M Costs: Approximately 65 to 75 kWh per ton of water evaporated.

Maintenance costs approximately 3% per year.

Figures are approximate and depend largely on equipment arrangement and structure for the equipment to be located, and the amount of wet cake and dry granule storage, which is included. The thermal energy requirement is approximately 1,250 to 1,300 BTU per pound of water evaporated. Technology is best suited for plants in the 5 to 500+ MGD range, but is cost competitive at lower capacities as well.

Vendor Name(s):

Andritz-Ruthner, Inc.
1010 Commercial Boulevard, South
Arlington, TX 76001
Phone: 817-419-1704 Fax : 817-419-1904
E-mail: peter.commerford@andritz.com
Website: www.andritz.com

Practitioner(s):

No practitioners of this technology for wastewater solids in the U.S. were identified. However, vendors can provide information on practitioners in other industries.

Schwing America, Inc.
Material Handling Division
5900 Centerville Road
St. Paul, MN 55127
Phone: 651-429-0999 Fax: 651-653-5481
E-mail: cwanstrom@schwing.com
Website: www.schwing.com

Technology Summary

Fluidized Bed Drying (Contd)

Key Words for Internet Search:

Fluid bed dryer, biosolids, sludge

Data Sources:

Vendor-supplied information and websites

Technology Summary

Chemical Drying

Objective: Solids are dried through chemical reaction. The dried product is mixed with nutrients to enhance the fertilizer value of the final product.	State of Development: Embryonic There are no installation or pilot facilities of this technology operating in the U.S.
--	--

Description:
 In the chemical drying process, ammonium salts or anhydrous ammonia and concentrated organic acids are mixed with dewatered biosolids. The organic acids (e.g., sulfuric acid, phosphoric acid) react with the ammonia in an extremely exothermic reaction. Sulfates and phosphates are produced in the reaction between the acid and the ammonia. The heat and pressure from the reaction sterilize the biosolids and complete the drying process. The reaction of the biosolids with the ammonium salts produces a hard granular material. As with other drying processes, the granular material can be combined with plant nutrients to further raise the nutritive value of the product.

Comparison to Established Technologies:
 Vendor claims indicate a final product similar to that produced by other drying technologies that is suitable for beneficial use (provided feed solids are of acceptable quality).

Available Cost Information:
Approximate Capital Cost: < \$ 4M for a 22 ton (25% solids) per day facility
 < \$10M for a 100 ton (25% solids) per day facility
Approximate O&M Costs: Not provided by the vendor.

Vendor Name(s): VitAG, LLC. 2111 Forest View Road Aiken, SC 29803 Phone: 239-398-6127 Fax : 803-652-2009 E-mail: Jburnham1@aol.com Unity Envirotech, LLC 1119 Burgundy Circle Pennsburg, PA 18077 Phone: 215-262-5233 Fax : 904-819-9224 E-mail: RTuttleUFC@aol.com	Practitioner(s): No practitioner at this time.
---	--

Key Words for Internet Search:
 VitAG, Unity, biosolids, sludge, chemical drying

Data Sources:
 Vendor-supplied information

Other Processes

8.1 Introduction

This chapter focuses on other processes that do not fit clearly into one of the other categories in this report.

8.2 Technology Assessment

Table 8.1 summarizes the state of development of other processes. Two of the technologies presented in this chapter are designed to significantly reduce either the volume or pathogen content of biosolids without all of the steps required by conventional methods. The Cannibal® process uses bacteria developed specifically to degrade biosolids' organic matter. The Lystek process uses heat and chemicals to produce a liquid biosolids product that is suitable for land application and meets Class A requirements. Use of biosolids as a fuel in cement kilns is also addressed.

Figure 8.1 includes an evaluation of the innovative technologies identified. Summary sheets for each process are provided in this chapter.

Table 8.1 – Other Processes—State of Development

Established	Innovative	Embryonic
N/A	Cannibal® Process Lystek Process Injection in Cement Kiln	N/A

Figure 8.1 – Evaluation of Other Innovative Processes

Process	Evaluation Criteria										Comments
	Development	Applicability	Potential Benefits	Beneficial Use	Impact on Other Processes	Complexity	Air Emissions	Energy	Footprint	Environmental	
Cannibal® Biosolids Destruction Process	N	I	C,O,V	N/A	▲	▼	▲	⊖	⊖	⊖	
Lystek Thermal/Chemical Process	N	I	C,O,A	N/A	⊖	▼	▲	▲	⊖	▲	
Injection in Cement Kiln	N	F	C,O,V,R	P	▲	⊖	⊖	▲	▲	▲	

<p>Statement of Development</p> <p>B = Bench scale D = Full-scale demonstrations in North America I = Full-scale industrial applications, with demonstrations or pilots for municipal sewage sludge O = Full-scale operations overseas N = Full-scale operations in North America P = Pilot</p>	<p>Applicability</p> <p>F = Few plants I = Industrywide L = Primarily large plants S = Primarily small plants</p>	<p>Potential Benefits</p> <p>A = Produces Class A biosolids C = Capital savings O = Operational/maintenance savings F = Produces high-nutrient fertilizer M = Minimizes odors R = Provides beneficial use (nonagricultural) V = Sludge volume reduction</p>	<p>Beneficial Use</p> <p>A = Agriculture C = Construction N/A = Not Applicable P = Power</p> <p>Comparative Criteria</p> <p>▲ Positive feature ⊖ Neutral or mixed ▼ Negative feature</p>
---	---	--	---

Technology Summary

Cannibal® Biosolids Destruction Process

Objective:

Biosolids volume reduction without digestion, thickening, dewatering or polymer addition

State of Development: Innovative

A 1 MGD sequential batch reactor wastewater treatment plant in Georgia began using the Cannibal solids reduction process in October 1998. The plant has purged solids once in five years to relieve the plant of extremely fine inert material buildup. The plant removed 8,000 pounds of wasted biosolids using the process between January 2000 and September 2003. Favorable results also have been realized at other full-scale operations within the United States. This process also has been successful at the Alpine Cheese Factory in Holmes County, Ohio, and has been the subject of bench-scale research at Virginia Polytechnic Institute and State University.

Description:

A portion of sludge from the main treatment process is pumped to a sidestream bioreactor where the mixed liquor is converted from an aerobic-dominant bacterial population to a facultative-dominant bacterial population. Aerobic bacteria are selectively destroyed in this sidestream reactor while enabling the facultative bacteria to break down and use the remains of the aerobes and their byproducts.

Mixed liquor from the bioreactor is recycled back to the main treatment process. There, the facultative bacteria, in turn, are out-competed by the aerobic bacteria and subsequently broken down in the alternating environments of the aerobic treatment process and the sidestream bioreactor.

Trash, grit and other inorganic materials are removed from the process by a patented solids separation module on the return sludge line. All of the return sludge is pumped through this module and recycled back to the main treatment process. Only a portion of this flow is diverted to the sidestream bioreactor for the selection and destruction process.

Comparison to Established Technologies:

Not similar to any established technology

Available Cost Information:

Approximate Capital Cost: Not available

Approximate O&M Costs: Not available

According to the vendor, a 1.5 MGD WWTP could recognize an approximate net operating cost savings of \$245,600 using the Cannibal process.

Vendor Name(s):

Envirex Products
1901 S. Prairie Ave.
Waukesha, WI 53189
Phone: 262-521-8570
Fax : 262-547.4120
E-mail: RoehlM@usfilter.com
website: www.usfilter.com

Practitioner(s):

Alpine Cheese Factory, Inc.
1504 US 62
Wilmont, OH 44689
Phone: 330-359-5454
Fax: 330-359-5049

Technology Summary

Cannibal® Biosolids Destruction Process (Contd)

Key Words for Internet Search:

Cannibal® process, biosolids, sludge

Data Sources:

Sheridan, J. and B. Curtis. "Casebook: Revolutionary Technology Cuts Biosolids Production and Costs." *Pollution Engineering*. 36:5 (2004).

Novak, J.T., D.H. Chon, B-A. Curtis, M. Doyle. "Reduction of Sludge Generation using the Cannibal® Process: Mechanisms and Performance." *Proceedings of WEF Residuals and Biosolids Management Conference 2006: Bridging to the Future.* Cincinnati, OH (12–14 March 2005).

Vendor-supplied information

Technology Summary

Lystek Thermal/Chemical Process

Objective:

Biosolids treatment and processing technology for production of high solids and pathogen-free product for beneficial use.

State of Development: Innovative

The process has been successfully demonstrated at a full-scale pilot facility at the Guelph Wastewater Treatment Plant in Ontario, Canada. It was able to produce a Class A biosolids of 12 to 15% solids. The product was stored without any change in product quality.

Description:

The Lystek process is a propriety sequenced batch operation where heat is applied and chemicals added to the feed solids in controlled conditions. Retention times are relatively short and the system can be fully automated to control the relevant parameters: pH, temperature and time. The resultant product is 12%–15% solids with a viscosity of < 1,500 cP (>2,000,000 cP of the feed) and is compatible with standard equipment used for land application. The resulting material retains the pump-ability needed to reduce the costs of biosolids handling, storage, transport and land application. The process has been shown to achieve the specifications required for Ontario NMA Class B biosolids and U.S. EPA Class A biosolids.

Comparison to Established Technologies:

Similar to digestion processes that use additives and heat to reduce pathogens.

Available Cost Information:

Approximate Capital Cost: \$1,000,000 – \$1,250,000

Approximate O&M Costs: \$120 – \$145 per dry metric ton

Capital cost estimates for the Lystek system are for a generic WWTP producing approximately 4,000 dry tons biosolids per year, and do not take into account any additional modification costs that may be necessary to integrate the Lystek system to the existing wastewater treatment plant. The cost will also depend on the nature of the biosolids produced by the plant. Operation and maintenance costs include material and energy

Vendor Name(s):

Lystek International, Inc.
107-279 Weber Street North
Waterloo, Ontario N2J 3H8
Canada
Phone: 519-880-2170
Fax : 519-747-8125
E-mail: info@lystek.com
Website: www.lystek.com

Practitioner(s):

City of Guelph Wastewater Services
530 Wellington Street
Guelph, Ontario N1H 3A1
Phone: 519-837-5629
E-mail: connie.mcdonald@guelph.ca or wastewater@guelph.ca

Key Words for Internet Search:

Lystek, biosolids, sludge

Data Sources:

Singh, A, F. Mosher, O.P. Ward, W. Key. "An advanced biosolids treatment and processing technology for beneficial applications of high solids and pathogen-free product." 3rd Canadian Organic Residues and Biosolids Management Conference, Calgary. (1–4 June 2005).

Technology Summary

Injection in Cement Kiln

Objective:

The objective for the wastewater treatment plant is cost effective, environmentally sound management of biosolids. The objective from the standpoint of the cement kiln is to reduce emission of nitrogen oxides (NOx) and/or fuel usage.

State of Development: Innovative

The technology is currently used for managing dewatered biosolids from a few wastewater treatment plants in California. It is also used to manage dried biosolids in a facility in Union Bridge, Maryland. A pilot study was conducted at the Maryland facility in 2004 and operation of the full scale facility began in 2006 under the terms of a six-month test fire permit. Heidelberg Cement (the parent company of Lehigh Cement, the owner of the Maryland facility) has been using this technology in Europe for a number of years

Description:

Biosolids are injected into cement kilns at different locations depending on the purpose of the biosolids. Biosolids can be used to reduce NOx emission and can serve as an alternate fuel source.

In reducing NOx emissions, the ammonia present in the biosolids reacts with oxygen to form nitrogen and water. In this application, dewatered biosolids are injected into the process at a point where temperatures are between 1600 and 1700° F (870 – to 930° C), typically, where the exhaust gases leave the kiln. This application is appropriate for preheater/pre-calciner kilns because in these plants, the target temperature range occurs at a location where it is feasible to inject the biosolids. In kilns of other designs the ideal temperature range occurs within the rotating portion of the kiln, an area where injecting the biosolids is not feasible. In addition to providing the means for the chemical reaction, the introduction of the biosolids at the point where exhaust gases leave the kiln also creates less favorable conditions for NOx formation by lowering the gas temperature. Through many years of operation, Mitsubishi's Lucerne Valley Cushenberry Plant in California has found that with a commercial injection rate of approximately 10 tons of dewatered biosolids per hour results in a small increase in electric load. That facility has also tested for increase in carbon monoxide and hazardous air pollutants (HAPs). There was no significant increase in HAPS. There were some notable increase in carbon monoxide emission but emissions remained below acceptable levels of 550 ppm.

Where biosolids are used to augment fossil fuels, dried biosolids (greater than 90% solids) are fed into the calciner combustion zone of the cement manufacturing process. During the initial pilot testing at the Lehigh Cement facility, the biosolids were mixed with the pulverized coal fuel. However, NOx emissions increased slightly with the use of biosolids at the Maryland facility, believed to be the result of increase rate of combustion. Currently, alternate feed locations are being investigated in an effort to reduce NOx emission while maximizing the use of biosolids. Testing of other emissions showed slight decrease in carbon monoxide, total hydrocarbons and sulfur dioxide.

In both applications there are no addition residuals to manage; ash is bound in the cement product and has been found to be compatible with the raw materials used in cement manufacture. However, adequate fan capacity must be provided to deal with steam vapor resulting from the use of biosolids in both applications. The vapor is more of a concern when the feed biosolids have lower percent solids.

Comparison to Established Technologies:

Not similar to any established technology.

Technology Summary

Injection in Cement Kiln (Contd)

Available Cost Information:

Approximate Capital Cost: Not applicable to biosolids generator; capital investment is made by cement kiln operator/owner.

Approximate O&M Costs: Cost varies regionally; tipping fees of less than \$5 per ton (wet) were quoted in the literature but will be influenced by the percent solids of the biosolids

Vendor Name(s):

Operators of cement kilns that have accepted biosolids include:

Lehigh Cement

7600 Imperial Way

Allentown, PA 18195

Phone: 610-366-4636

Email: emorton@htcnam.com

Mitsubishi Cement Corporation

5808 State Highway 18

Lucerne Valley, CA

Phone: 760-248-737

Practitioner(s):

Joint Water Pollution Control

24501 S Figueroa Street

Carson, CA

Synagro-Baltimore LLC

Key Words for Internet Search:

Cement kiln biosolids injection

Data Sources:

Battye, R., S. Walsh, J. Lee-Greco. NOx Control Technologies for the Cement Industry, Final Report. (2000).

Kahn, Robert. "Biosolids Injection: A New Technology for Effective Biosolids Management," Undated.

Morton, Edward L. "A Sustainable Use for Dried Biosolids." Undated.

Cement Industry Environmental Consortium website, www.cieconline.net.

Vendor-supplied information.



*Lehigh Cement plant in Union Bridge, Maryland.
(Photo courtesy of Lehigh Cement. 2006.)*

Research

9.1 Introduction

In order to reclassify any technology which is considered to be innovative or embryonic, additional research and field demonstration projects are necessary. This chapter focuses on specific technologies that may have a significant impact on biosolids treatment and management, and the relevant research needs in these areas.

9.2 Research Needs

Sound, sustainable biosolids management is based upon controlling and influencing the quantity, quality and characteristics of biosolids in such a way that negative impacts to the environment are avoided and beneficial uses are optimized. It is recognized that each wastewater treatment facility in the United States faces unique circumstances resulting in a variety of applicable biosolids management strategies. Biosolids treatment technologies are used to achieve beneficial use to the greatest extent possible. Table 9.1 identifies research needs for especially promising technologies in biosolids treatment. Beneficial use can take advantage of the soil conditioning and fertilizing properties of this material or it may include gas and energy production. Substantial scientific research will enable the beneficial use of biosolids to continue to expand by reducing the uncertainties and data gaps on the potential effects of biosolids exposure to human health. Research is used to determine whether current practices need to be altered. Emerging and innovative technologies can provide new cost-efficient and effective solutions to biosolids management. Some steps towards completing scientific research include: “development and standardization of sampling and analytical methods, investigation of contaminant fate/transport and exposure routes, potential human health effects, risk assessment determinations; evaluation of improvements that may be needed in operational practices, technologies, and management practices for biosolids treatment and reuse.” (WERF, 2002).

Table 9.1 – Research Needs Technologies: State of Development

Technology Type	Technology	Focus of Investigation
Conditioning	None	None.
Thickening	None	None.
Stabilization	Temperature-Phased Digestion	Confirm solids reduction and gas production. Determine SRT needed vs. conventional anaerobic digestion. Identify operating problems – Thermophile Heating/Heat Recovery.
	Two-Phase Digestion	Confirm solids reduction and gas production. Determine SRT needed vs. conventional anaerobic digestion. Identify operating problems.
	Ferrate Addition	Confirm performance, costs and viable operating parameters.
	Neutralizer®	Confirm performance, costs and viable operating parameters.
Dewatering	None	None.
Thermal Conversion	RHOX Process	Document improvement in plant capacity and decrease in emissions. Determine impact on capital and operating costs.
	Gasification	Conduct testing at several locations. Document improvements in plant capacity and decrease in emissions. Determine impact on capital and operating costs.
	Sludge-to-Oil	Conduct testing at several locations. Document improvements in plant capacity and decrease in emissions. Determine impact on capital and operating costs.
	Supercritical Water Oxidation	Conduct testing at several locations. Document improvements in plant capacity and decrease in emissions. Determine impact on capital and operating costs.
	SlurryCarb™	Conduct testing at several locations. Document improvements in plant capacity and decrease in emissions. Determine impact on capital and operating costs.
	Deep-Shaft Wet Air Oxidation	Conduct testing at several locations. Document improvements in plant capacity and decrease in emissions. Determine impact on capital and operating costs.
	Drying	Belt Drying
Direct Microwave Drying		Determine capital and operating costs. Identify operating problems/confirm performance.
Flash Drying		Determine capital and operating costs. Identify operating problems/confirm performance.
Fluidized Bed Drying		Determine capital and operating costs. Identify operating problems/confirm performance.
Chemical Drying		Confirm performance, costs and viable operating parameters.
Cannibal®		Document improvements in performance. Determine impact on capital and operating costs.
	Lystek	Document improvements in performance. Determine impact on capital and operating costs.

Generally, research and technical issues can be grouped into three areas:

- (1) Analysis and reduction of risk associated with beneficial use practices;
- (2) Utilization of the potential of biosolids to yield energy; and,
- (3) Improved operation, performance, and efficiency of biosolids treatment processes.

9.2.1 Analysis and Reduction of Risk Associated with Certain Beneficial Use Practices

Fundamental research in this area relates to:

- Standardization of sampling and analytical methods for contaminants to assure the use of the best measurement methods for particular microbial and chemical contaminants. This standardization should also state the best time and place for sampling.
- Standardization of risk assessment measures and methods for chemicals and pathogens. Risk assessment allows for the evaluation of operational improvement practices and technologies. This evaluation would differ from most plant efficiency evaluations by focusing on the treatment practices and the protections they offer to human and environmental health.
- Fate and transport of the contaminants during biosolids management practices.
- Emerging chemical contaminants and pathogens, as well as on exposure measurements and routes. The potential health risks and effects should be addressed to determine the adverse effects of the emerging contaminants.
- Resolution of issues that affect the acceptability of Class B biosolids to continue in the future.
- Reactivation of fecal coliforms in centrifuge dewatered solids, anaerobically digested biosolids.

9.2.2 Utilization of the Potential of Biosolids to Yield Energy

Fundamental research in this area relates to:

- Research on technologies that can generate or increase the quantity of energy from the production of biosolids by-products and gases.
- Utilization of process-generated gas to provide energy to offset at least some of the energy requirements of wastewater and biosolids treatment technologies.

9.2.3 Improved Operation, Performance and Efficiency of Biosolids Treatment Processes

- Optimization of the application of chemicals for dewatering and their impact on the quality of the final product.
- Assessment of the odor potential from biosolids stabilization and dewatering techniques and advances to mitigate odor emissions.
- New technologies for the production of artificial soils and fertilizer components or products.
- Emergence of high temperature, high-volume solids destruction technologies.
- Improvements in energy efficiency, particularly the use of heat exchangers and heat recovery.

9.2.4 Research Needs

The technologies are arranged by type, noting the recommended focus of the investigations for each.

Selection of the technologies and their research needs is based upon an assessment of the process summaries and evaluations in the previous chapters. Criteria used to select the technologies include applicability, judgment about critical assessments needed to promote the technology to the next level of development, promise for further development and current interest in the technology.

9.2.5 Chapter References

Water Environment Research Foundation (WERF) (2002).
www.werf.org/funding/researchplan.cfm

WERF (1999) *Biosolids Management Evaluation of Innovative Processes*.

Great Lakes By-products Management Association
15743 Hagenderfer Road, Plain City, OH 43064
Phone: 866-309-7946
Web: <http://glbma.org>

Mid-Atlantic Biosolids Association
Web: <http://www.mabiosolids.org>

National Biosolids Partnership
601 Wythe Street, Alexandria, VA 22314
Phone: 703-684-2400
Web: <http://www.biosolids.org>

North East Biosolids & Residuals Association
P.O. Box 422 Tamworth, NH 03886-0422
Phone: 603-323-7654
Web: <http://www.nebiosolids.org>

Northwest Biosolids Management Association
201 S. Jackson St Seattle, WA 98104-3855
Phone: 206-684-1145
Web: <http://www.nwbiosolids.org>

Water and Wastewater Equipment Manufacturers Association (WWEMA)
P.O. Box 17402, Washington, D.C. 20041
Phone: 703-444-1777
Web: <http://www.wwema.org>

Water Environment Federation
601 Wythe Street, Alexandria, VA 22314-1994
Phone: 703-684-2452
Web: <http://www.wef.org>

Water Environment Research Foundation
635 Slaters Lane, Suite 300, Alexandria, VA 22314
Phone: 703-684-2470
Web: <http://www.werf.org>

Air and Waste Management Association
One Gateway Center, 3rd Floor, 420 Fort Duquesne Blvd.
Pittsburgh, PA 15222-1435
Phone: +1-800-270-3444
Web: <http://www.awma.org/>

National Association of Clean Water Agencies
1816 Jefferson Place, NW Washington D.C. 20036
Phone: 202.833.2672
Web: <http://www.nacwa.org/>