

# TECHNICAL PRESERVATION GUIDELINES

APRIL 2009

## UPGRADING HISTORIC BUILDING LIGHTING

CAROLINE ALDERSON

### EXECUTIVE SUMMARY

Historic light fixtures and the quality of light they produce, in combination with original daylighting features, contribute significantly to the character and authenticity of historic buildings. Many historic buildings, unfortunately, have been compromised by inappropriate lighting alterations. Electrical upgrades, space alterations and modernization projects often provide opportunities to reclaim compromised historic character while improving a historic building's marketability and value.

This guide focuses on preservation-appropriate solutions for modifying and supplementing historic incandescent lighting to reduce energy use and improve lighting functionality. Although this guide does not address in detail upgrading of modern-era fluorescent lighting, many of the solutions outlined here are applicable to buildings and fixtures of any era.

Additional guidance for meeting other lighting improvement goals is available from GSA's High Performance Green Buildings program. All projects affecting historic building restoration zones require review by GSA's Regional Historic Preservation Officer (RHPO), beginning early in project planning to ensure that design scopes, qualifications, and budgets address preservation compliance requirements.

Historic lighting qualities to be considered in planning GSA historic buildings projects include:

- Electric lighting thoughtfully supplementing daylight
- Variable light levels with electric lighting placed to support tasks and highlight architectural design
- Lamps in a temperature range that casts "warm" light

Successful lighting design for GSA historic buildings considers a variety of factors for meeting multiple goals, including, but not limited to:

- Preservation of historic materials and character,
- Occupant comfort,
- Energy conservation,
- Initial costs,
- Operational costs,
- Maintenance requirements,

- Disposal costs and environmental impact, and
- Esthetics.

Historic chandeliers and other decorative fixtures in historic spaces may need to be restored or replicated. These fixtures may be retrofitted with appropriate compact fluorescent lamps, reflectors, and other light sources to increase light output and energy efficiency. New high efficiency incandescent lamps should be used for historic light fixtures with exposed incandescent bulbs. Any new supplementary lighting necessary to meet GSA lighting requirements should be designed and placed inconspicuously to avoid detracting from the historic lighting and architecture. All lights can be placed on motion sensors to conserve energy when spaces are not occupied. Supplementary lights can be activated by daylight sensors, where appropriate, to meet space lighting needs when daylight is insufficient.

Indirect lighting tucked in coves or on cornices, combined with task lighting, can be a good alternative for boosting light levels in historically significant spaces. Simple sconces designed to blend into walls are another preservation-appropriate option for increasing ambient light levels without competing with historic ceiling lights. Recessed ceiling lights should be installed only as a last resort for supplementing historic ceiling lights and may be installed only in ceiling perimeters.

To ensure that GSA's preservation and performance expectations are met, specifications for historic lighting replication, modification, or supplementation need to include requirements for product data, sample review and mock up test installation.



FIGURE 1 Electric lighting thoughtfully supplements daylight in this historic lobby.

## INTRODUCTION

Historic light fixtures and daylighting play a major part in a building's unique historic character. GSA's historic public buildings typically offer abundant windows and light courts admitting generous daylight to perimeter offices in doubled loaded corridor floor plans. Awnings, shades, and blinds provided light and glare control for exterior windows, with transoms, glazed doors, and glazed partitions admitting light into corridors and other interior spaces. Skylights provided daylight for spaces lacking windows.

Ceremonial corridors, stairways and public spaces were often embellished with custom-fabricated pendant lights, chandeliers, or sconces hung from ornamental ceilings and walls. Desk lamps and torchieres supplemented ceiling lights in standard offices and courtrooms to put light where it was most needed.



FIGURE 2 Variable light levels and multiple light sources contribute to the historic character and elegance of this early 20th century courtroom.

When fluorescent lighting emerged as the principal approach for achieving uniformly high light levels, daylighting features such as glazed transoms and partitions were often removed or obscured. Skylights were commonly covered over as an emergency measure for public safety during World War II blackouts or during subsequent roof repairs to eliminate maintenance. At some historic buildings, original light fixtures have been replaced with inappropriate lighting that introduces glare from lamps rendering cool hues unsympathetic with the building's historic character.



FIGURE 3 Interior upgrade projects often provide opportunities to restore compromised spaces and make a historic building more marketable.

GSA's Green Building program, initiated in 1999 and renamed the High Performance Green Buildings program in 2008, provides guidance on sustainable design, energy efficiency, resource conservation, and workspace quality for GSA repair and alteration projects of all scales. There are many ways that energy reduction and workspace needs can be met while preserving character-defining historic light fixtures and making the most of inherent energy conserving features in historic buildings. Lighting upgrades and interior renovation projects often provide opportunities to remove inappropriate alterations and restore compromised spaces to improve tenant satisfaction and make a historic building more marketable.



FIGURE 4 Good lighting depends on effective distribution of natural and electric light.

New guidelines recognize that good workspace lighting depends as much on effective light distribution as light output measured in foot candles and that excessive lighting can hamper productivity while consuming more energy than necessary. Uniform high-output "factory style" ambient lighting approaches formerly used to upgrade open area workspaces are no longer considered appropriate for most GSA properties. Variable lighting levels tailored to the specific tasks and design of a historic space can support preservation goals while improving workspace quality and comfort. Multiple lighting sources offer greater flexibility for addressing differing needs for ambient, task, safety, and accent lighting.

## FEDERAL GUIDES AND STANDARDS

Every successful GSA historic building project begins with review of the specific building's Building Preservation Plan (BPP) or Historic Structure Report (HSR) to ensure that GSA teams involved in developing project requirements and overseeing design and execution are well informed on the building's preservation goals at the earliest stages of project planning and design. The BPP or HSR identifies spaces of architectural importance and character-defining features, such as historic light fixtures, to be preserved. BPPs and HSRs also outline restoration goals for altered public spaces, sometimes including original detail drawings of original fixtures as a basis for replication.



FIGURE 5 GSA Building Preservation Plans identify spaces of architectural importance and character-defining features, including historic light fixtures, to be preserved.

Standards and guidance for all federal projects involving historic buildings are provided in the Secretary of the Interior's Standards for Rehabilitation and guidelines for applying the standards published by the National Park Service (NPS), U.S. Department of the Interior (DOI Standards). The National Park Service has also published a variety of briefs and technical guidance addressing a range of lighting improvement issues. All guidance publications are available free online at [www.nps.gov/hps/tps/publications.htm](http://www.nps.gov/hps/tps/publications.htm).

Central to the DOI Standards, which are based on European standards used throughout the world, are the principal goals of:

- maintaining authenticity, by
- doing no harm to historic materials,
- designing changes sympathetically, and
- restoring significant spaces correctly, based on historic documentation.

GSA's PBS P100 Facility Standards provide guidance for lighting improvements at GSA historic properties, as follows:

## PBS P100 Federal Standards for the Public Buildings Service

### Chapter 6. Electrical Engineering, Lighting – Historic Structures

Historic fixtures may be upgraded with energy efficient lamps, ballasts, reflectors, or other means to achieve required light levels, if changes can be made without affecting the appearance of the fixture. Energy efficient light sources should match the warm to white color range of incandescent light or daylight as closely as possible. In restoration zones, opportunities should be sought to replace unsympathetic contemporary lighting with replicas of original historic fixtures. Replica fixtures in which light sources are not exposed should incorporate high output, energy efficient lamps as necessary to achieve required light levels and meet energy conservation standards. Supplemental lighting, if required, should be designed and installed to avoid competing visually with historic lighting. Freestanding torchieres, task lighting and discrete accent lighting are recommended for increasing light levels in ceremonial spaces containing ornamental ceilings and historic chandeliers.

## RETROFITTING HISTORIC LIGHTS

The simplest method of reducing energy use in spaces containing historic light fixtures with incandescent bulbs concealed by translucent or opaque globes, shades, or lenses, is to replace the incandescent bulbs with compact fluorescent lamps. Changing to a fluorescent source with color temperature as close as possible to that of the incandescent lighting will help to ensure against lighting color changes that may have a negative impact on the appearance of historic finishes and features.

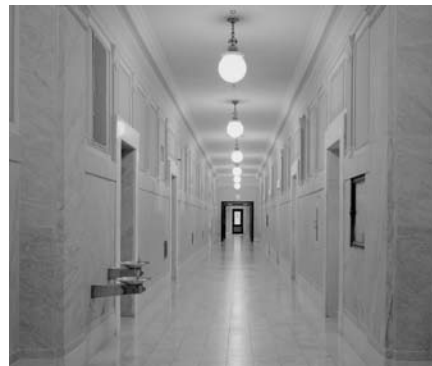

FIGURE 6 The simplest method of reducing energy use in spaces containing historic light fixtures is to replace the incandescent bulbs with compact fluorescent lamps. Reballasting increases the energy savings.

Historic chandeliers featuring exposed incandescent bulbs can be upgraded to receive High Efficiency Incandescent (HEI) lamps that use 25% of the energy standard incandescent bulbs use (available in 2010.) Historic fixtures may also be remodified to include additional light sources, such as light emitting diodes (LEDs) or fiber optics where modifications can be done inconspicuously and lamp temperatures (color) will be compatible. The use of color-incompatible lamps, such as halide, as the sole light source is not appropriate, given differential color shifting that occurs as lamps age. Select lamps providing color temperatures as close as possible to that of original lighting. Lighting consultants specializing in historic lighting are best qualified to analyze existing historic lighting (foot candles and temperature) and identify appropriate alternatives.



FIGURE 7 Installing high-efficiency incandescent (HEI) lamps in historic exposed bulb fixtures reduces energy use by 50-75 percent with no impact on the appearance of the fixture.

Reproduction historic lights for significant spaces such as courtrooms may be fitted with a combination of light sources and separate switch settings to allow for multiple light levels such as a working light level and historic light level for ceremonial events. In historic spaces requiring increased light levels, apply the following order of preference:

1. Retrofit historic lights
2. Supplement historic lights with discretely placed, preferably indirect, lighting to avoid competing with historic lighting.

## REPLICATING HISTORIC LIGHTS

Historic lighting replication projects often create opportunities to improve lighting performance and energy efficiency in a visually authentic reproduction fixture. Most period lights can accommodate ballasts for compact fluorescent lamps and some will accommodate a substantial reconfiguration of concealed lighting sources for improved light output.

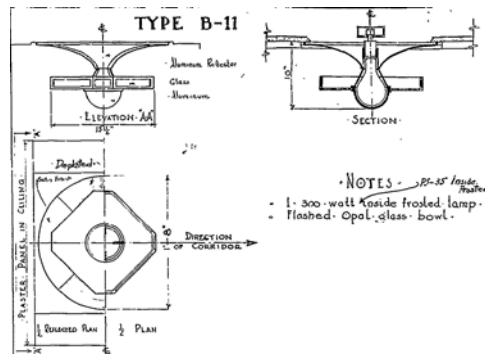

FIGURES 8-10 Replica historic ceiling light incorporating a lengthened pendant and CF bulbs to provide side lights in addition to the historic fixture's downlight, originally provided by a single incandescent bulb.

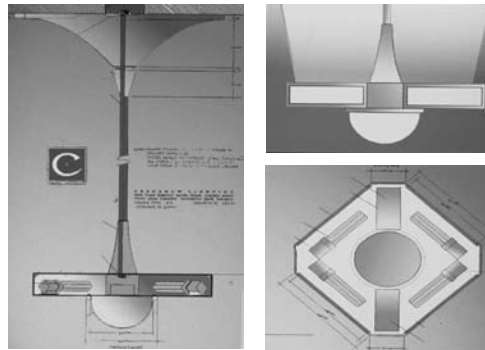

## INTEGRATING DAYLIGHT

Recent research increasingly links daylight with productivity and health. Poor daylighting can lead to uncomfortable work environments, low employee satisfaction, poor productivity, and untenable buildings. Effective daylighting reduces the energy required to light and heat a building. Most historic office buildings, fortunately, were designed with generous windows and a variety of features to convey and manage daylight through surface transparency, diffusion, and daylight control.

Historic daylighting design elements include:

- Windows and window shading devices
- Skylights and laylights
- Glazed doors, transoms, and sidelights

- Glazed and low partitions
- Transparent, translucent and reflective surfaces

Appropriately designed and installed window treatments (shades, blinds) and treated glazing control heat gain and glare while maintaining window views and admitting daylight. Some shading systems use photosensor-driven operating devices to increase or reduce daylight based on outdoor conditions. Energy conserving glazing films change thermal conductivity to control heat gain. Low-e films, as they are known, come in a variety of types that range in visual impact from negligible to inappropriately reflective for use on historic buildings.

Since the amount of light penetrating a room is limited by the height of the opening, it is important that windows are not partially blocked by suspended ceilings, wall partitions and other alterations. Design suspended ceilings to be recessed from window openings by creating pockets or soffits around windows or configuring ceilings to slope upward toward the head of the window or step down toward the corridor to accommodate ductwork and other building systems.



FIGURE 11 Preserve window opening clearance by recessing suspended ceilings from windows or configuring ceilings to slope upward toward the window head or step down toward the building interior.

Low or glazed partitions allow light to penetrate into open office workspaces for building occupants not seated along exterior walls. Studies show that employees will generally choose a space offering generous daylight over a space offering privacy with no daylight, underscoring the importance of workspace design features that allow light to penetrate as far as possible into the building floorplate.

Glazed doors, transoms, and interior windows “borrow” or capture daylight from exterior windows to provide natural lighting in corridors and interior spaces that otherwise would have little or no daylight. It is important to maintain the transparency (or translucency) of these features to gain these intended daylighting benefits.



FIGURE 12 Low partitions and glazed partitions allow light to penetrate into workspaces.

Many historic buildings include skylights designed to admit daylight to interior cores, underground spaces and other windowless areas. Skylight systems typically include interior laylights that may include a daylight control mechanism. Skylight repair and replication projects provide opportunities to improve the thermal performance and life-cycle of these assemblies while improving the marketability of windowless workspaces.

Reflective finishes such as polished stone walls and terrazzo floors can contribute significantly to lighting levels in corridors and other public spaces and also to the perception that these spaces are adequately lit. Accordingly, installation of carpeting or light absorbing materials outside of office areas where they are necessary for workspace noise reduction should be discouraged.



FIGURE 13 Reflective surfaces contribute significantly to lighting levels and quality in corridors and other public spaces.

All lights can be placed on motion sensors to conserve energy when spaces are not occupied. Supplementary lights can be activated by daylight sensors, where appropriate, to meet space lighting needs when daylight is insufficient.

For additional guidance on integrating daylight design, electrical illumination, architectural design and mechanical systems, refer to P100 6.8 Interior Lighting, Daylighting, and Control Systems. See also NPS Preservation Note 44 *Natural Light in Historic Buildings*.

## SUPPLEMENTAL LIGHTING

Where historic fixtures cannot accommodate additional light sources or modification of existing lights will not achieve necessary light levels, existing light may be supplemented by contemporary lighting carefully designed and placed to maintain the visual predominance of the space's historic lighting.

First consideration for supplementing historic lights should be given to traditional task lighting solutions such as desk lamps that place light where it is needed to perform work. Most open space furniture systems feature task lighting integrated into workspace shelving, significantly reducing ambient lighting needs. Occupants should be encouraged to use and maintain task lighting. In combination with photo-sensors and manual controls that reduce demand for ambient lighting in large work areas, task lighting gives occupants a means of controlling light levels within their own workspace, often netting substantial savings, as workers tend to prefer less ambient light than is typically installed in contemporary offices.



FIGURES 14-16 Traditional supplemental lighting such as desk lamps preserve the architectural dominance of historic chandeliers and place light where it is needed to perform work.



When historic fixture modifications and task lighting cannot adequately address ambient lighting needs, explore additional light-supplementing options that will not compete with historic lights. In historically significant spaces, supplementing chandeliers, pendant lights or other ceiling mounted lights with wall mounted sconces, uplights mounted on furniture, or freestanding lamps is preferable to installing additional ceiling fixtures.



FIGURE 17 Contemporary sconce lights illuminate walls and ceilings in corridors where daylight originally served as the principal light source for this 19th-century post office. The opaque shades of the sconces reflect light against the walls of the corridor,

rather than beaming light down on corridor occupants, subtly maintaining the visual dominance of the skylit atrium the corridors overlook.



FIGURE 18 Quietly designed sconces maintain visual focus on the historic chandeliers and decorative finishes embellishing this historic courtroom.

Contemporary wall sconces or staggered channel fluorescent or cold cathode tube lighting concealed in coves or on cornices may be used illuminate corridor walls and ceilings with reflected light that maintains historic character and does not compete with historic ceiling lights or character-defining daylighting features.

Installing recessed or other ceiling lights in significant spaces containing original or reproduction ceiling lights should be considered as a last resort only for achieving light levels required to make a space functional. Recessed down lights may only be installed outside of the central ceiling field, along the perimeter or other edge locations. Care should be taken to avoid high output, direct lighting sources that may overpower or distract from ornamental historic lighting, reducing it to an architecturally and functionally ancillary role.



FIGURES 19-20 Limit recessed lighting to the ceiling perimeter to avoid overpowering historic chandeliers and changing the character of historic ceilings.



- Maintaining a stock of replacement lamps;
- Ensuring that new and historic fixtures have similar temperature lamps to avoid mixing “warm” and “cool” hues in the same space; and
- Relamping fixtures with a space as a group to avoid uneven temperature (light color) distribution, as lamps change temperature over time.

## CONCLUSION

For all lighting modifications within historic building restoration zones, be sure to specify sample review of any new or modified lighting to be installed and require a mock up installation for RHPO and tenant review and approval prior to overall fabrication and installation, to ensure that preservation design criteria and the project’s performance and esthetic requirements have been met. Budgeting time and funding for mock up installation serves as insurance against the possibility of cost increases and delays if a planned solution falls short of GSA and tenant expectations. Allow time and funds to make appropriate lighting adjustments.

Help GSA promote imaginative solutions that preserve historic lights and make the most of original daylighting and architectural features that make GSA’s historic buildings unique and valuable. To share images and information documenting your own project successes for the benefit of future updates to this guide, contact [caroline.alderson@gsa.gov](mailto:caroline.alderson@gsa.gov).

For additional guidance and building specific information, contact your RHPO (see [www.gsa.gov/historicpreservation](http://www.gsa.gov/historicpreservation)>Contacts for a current listing).

## SPECIAL ISSUES

Modern-era buildings often contain historic fluorescent fixtures that need to be replaced or relamped for energy conservation or improved performance. Lighting specialists and architects specializing in buildings of this era are more equipped to assess the significance and adaptability of original lighting fixtures and the availability of appropriate replacement lighting than generalists unfamiliar with the unique attributes and requirements of modernist buildings. Modern-era light lenses, for example, may be significant components of the fixtures, but degraded, requiring analysis of conservation and component replacement options.

Exterior facade lighting and interpretive lighting to illuminate artwork or exhibits require specialized lighting design skills to identify options satisfying the interpretive, conservation, and maintenance needs of materials being illuminated. Any specialists retained to plan, design, or install exterior or interior interpretive lighting at historic properties must demonstrate an understanding and support of federal preservation standards and GSA preservation policy.

## MAINTENANCE PLANNING

Maintenance planning as part of design contributes to lighting solutions that perform well over the long term. Recommended steps for the continued success of a historic building lighting upgrade include:

- Confirming the convenient availability of replacement lamps for new and upgraded fixtures before committing to purchasing or modifying any fixture;