

UNITED STATES COMMISSION OF FISH AND FISHERIES  
SPENCER F. BAIRD, COMMISSIONER

---

THE FISHERIES  
AND  
FISHERY INDUSTRIES  
OF THE  
UNITED STATES

---

PREPARED THROUGH THE CO-OPERATION OF THE COMMISSIONER OF FISHERIES  
AND THE SUPERINTENDENT OF THE TENTH CENSUS

BY  
GEORGE BROWN GOODE  
ASSISTANT SECRETARY OF THE SMITHSONIAN INSTITUTION  
AND A STAFF OF ASSOCIATES

SECTION V  
HISTORY AND METHODS OF THE FISHERIES  
IN TWO VOLUMES, WITH AN ATLAS OF TWO HUNDRED AND FIFTY-FIVE PLATES  
PLATES

---

WASHINGTON  
GOVERNMENT PRINTING OFFICE  
1887

ASSOCIATE AUTHORS.

---

JOEL A. ALLEN .....	Museum of Comparative Zoology, Cambridge.
TARLETON H. BEAN .....	U. S. National Museum, Washington.
JAMES TEMPLE BROWN .....	U. S. National Museum, Washington.
A. HOWARD CLARK .....	U. S. National Museum, Washington.
CAPTAIN JOSEPH W. COLLINS .....	Gloucester, Massachusetts.
R. EDWARD EARLE .....	U. S. Fish Commission, Washington.
HENRY W. ELLIOTT .....	Cleveland, Ohio.
ERNEST INGERSOLL .....	New Haven, Connecticut.
DAVID S. JORDAN .....	Indiana University, Bloomington, Indiana.
LUDWIG KUMLIEN .....	Milwaukee, Wisconsin.
MARSHALL McDONALD .....	U. S. Fish Commission, Washington.
FREDERICK MATHER .....	N. Y. Fish Commission, Cold Spring, New York.
BARNET PHILLIPS .....	Brooklyn, New York.
RICHARD RATHBUN .....	U. S. National Museum, Washington.
JOHN A. RYDER .....	U. S. Fish Commission, Washington.
CHARLES W. SMILEY .....	U. S. Fish Commission, Washington.
SILAS STEARNS .....	Pensacola, Florida.
FREDERICK W. TRUE .....	U. S. National Museum, Washington.
WILLIAM A. WILCOX .....	Gloucester, Massachusetts.

## LIST OF PLATES TO SECTION V.

[Engraved by the Photo-Engraving Company of New York City.]

(Page references to Volumes I and II of text.)

### THE FRESH HALIBUT FISHERY.

	Vol.	Page.
1. Halibut schooner under jib, foresail, and double-reefed mainsail; nests of dories on deck amidships; rigged for fall and winter fishing .....	I,	7
Drawing by Capt. J. W. Collins.		
2. Halibut schooner in summer rig, two topmasts up and all sails spread .....	I,	7
Drawing by Capt. J. W. Collins. (Engraved by Photo-Electrotype Company.)		
3. FIG. 1. Sectional plan of halibut schooner. (See page opposite plate for explanation) .....	I,	7
FIG. 2. Deck plan of halibut schooner. (See page opposite plate for explanation) .....	I,	9
Drawings by Capt. J. W. Collins.		
4. Sectional plan of well-smack employed in the fresh halibut fishery on George's Bank, 1836 to 1845. (See page opposite plate for explanation) .....	I,	41
Drawing by Capt. J. W. Collins.		
5. FIG. 1. Bait chopper .....	I,	12
FIG. 2. Bait slivering knife .....	I,	12
FIG. 3. Halibut killer and gob stick .....	I,	17
FIG. 4. Woolen hand nipper .....	I,	10
FIG. 5. Halibut gaff .....	I,	17
FIG. 6. Trawl buoy and black ball .....	I,	11
FIG. 7. Canvas skate for section of trawl .....	I,	11
FIG. 8. Dory scoop .....	I,	10
* Drawings by Capt. J. W. Collins.		
6. FIG. 1. Hurdy-gurdy to haul trawls in deep water .....	I,	10, 11, 16
FIG. 2. Dory showing mode of attaching and using the hurdy-gurdy .....	I,	10, 11, 16
FIG. 3. Trawl roller attached to dory gunwale for hauling trawls in shoal water .....	I,	10
Drawings by Capt. J. W. Collins.		
7. Cutting bait and baiting trawls on halibut schooner at anchor on the fishing grounds .....	I,	12
Drawing by H. W. Elliott and Capt. J. W. Collins.		
8. Dories and crew on the way to haul the trawls; the schooner at anchor under riding sail .....	I,	13-16
Drawing by H. W. Elliott and Capt. J. W. Collins.		
9. Halibut dory and crew hauling the trawl, gaffing and clubbing the halibut .....	I,	16
Drawing by H. W. Elliott and Capt. J. W. Collins.		
10. Dory and crew caught to leeward in a storm while hauling the trawl; trawl-buoy and line drifted astern of the vessel for their rescue .....	I,	16, 80
Drawing by H. W. Elliott and Capt. J. W. Collins.		
11. Halibut schooner at anchor on the Grand Bank in winter, riding out a gale .....	I,	84
Drawing by H. W. Elliott and Capt. J. W. Collins.		
12. Halibut schooner "lying-to" in a gale on the Bank, under riding sail and double-reefed foresail. Drawing by H. W. Elliott and Capt. J. W. Collins.	I,	77
13. Halibut schooner tripped by a heavy sea .....	I,	71
Drawing by H. W. Elliott and Capt. J. W. Collins.		
14. Halibut schooner in winter, head-reaching under short sail .....	I,	20
Drawing by H. W. Elliott and Capt. J. W. Collins.		

	Vol.	Page.
15. Old-style halibut schooner, hand-line fishing from deck, 1840 to 1850.....	I,	29-43
<i>Drawing by H. W. Elliott and Capt. J. W. Collins.</i>		
16. Dressing halibut on deck of schooner for icing in the hold .....	I,	19
<i>From photograph by T. W. Smillie.</i>		
17. FIG. 1. Halibut cutting knife.....	I,	19
FIG. 2. Scraping knife to remove muscle and flesh from backbone after cutting .....	I,	19
FIG. 3. Squillgee for pushing ice in pen.....	I,	19
FIG. 4. Oak mallet for breaking ice.....	I,	19
FIG. 5. Oak broom for scrubbing halibut .....	I,	19
<i>Drawings by Capt. J. W. Collins.</i>		
18. General view of schooner discharging fare of fresh halibut at Gloucester, Mass.....	I,	21
<i>Drawing by Capt. J. W. Collins.</i>		
19. Hoisting halibut from hold of schooner at Gloucester, Mass.....	I,	21
<i>From photograph by T. W. Smillie.</i>		
20. Weighing and selling halibut on deck of George's Bank hand-line cod schooner.....	I,	22
<i>Drawing by H. W. Elliott and Capt. J. W. Collins.</i>		
21. Handling fresh halibut at Gloucester, Mass.; weighing, unheading, and packing in ice for shipment by rail.....	I,	22
<i>Drawing by H. W. Elliott.</i>		
22. Packing fresh halibut at Gloucester, Mass.; preparing ice with pick and grinding machine; nailing covers on the boxes; use of devil's claw .....	I,	22
<i>Drawings by H. W. Elliott.</i>		

## THE BANK HAND-LINE AND TRAWL COD FISHERIES.

23. Old style Grand Bank cod schooner; crew at rails hand-line fishing.....	I,	125, 126
<i>Drawing by H. W. Elliott and Capt. J. W. Collins.</i>		
24. Hand-line dory cod fishing on the Grand Bank .....	I,	126
<i>Drawing by H. W. Elliott and Capt. J. W. Collins.</i>		
25. Deck plan of schooner Centennial, of Gloucester .....	I,	149
<i>Drawing by Capt. J. W. Collins.</i>		
26. Dory and crew setting cod trawls on the Bank .....	I,	152, 176
<i>Drawing by H. W. Elliott and Capt. J. W. Collins.</i>		
27. Underrunning cod trawls; two methods of setting trawl for underrunning.....	I,	177
<i>Drawing by Capt. J. W. Collins.</i>		
28. Newfoundland fishermen catching squid for sale as cod bait to United States vessels.....	I,	152, 164
<i>Drawing by H. W. Elliott and Capt. J. W. Collins.</i>		
29. Dory crew of cod fishermen catching birds for bait.....	I,	152
<i>Drawing by H. W. Elliott and Capt. J. W. Collins.</i>		
(For illustration of cod schooners discharging cargoes see Section on Preparation of Fishery Products.)		

## THE GEORGE'S BANK COD FISHERY.

30. Gloucester schooner at anchor on George's Bank in winter; hand-line fishing for cod; rigged without topmasts for rough weather.....	I,	130-193
<i>From painting by Paul E. Collins, Boston, Mass.</i>		
31. Cod hand-line gear.....	I,	192
FIG. 1. Lead sinker with brass horse and swivels.		
FIG. 2. George's Bank gear with sling-ding, &c.		
FIG. 3. Hand-line gear for shoal water.		
<i>Drawings by Capt. J. W. Collins.</i>		
32. George's Bank crew hand-line fishing, gaffing fish over the rail, cutting out tongues.....	I,	194
<i>Drawing by H. W. Elliott and Capt. J. W. Collins.</i>		
33. Dressing cod on deck of fishing schooner.....	I,	156, 180,
<i>Drawing by H. W. Elliott and Capt. J. W. Collins.</i>		
		186
34. Discharging fare of George's Bank cod at Gloucester wharf.....	I,	185
<i>Drawing by H. W. Elliott, 1882.</i>		
35. Splitting and washing George's Bank cod at Wonsen's wharf, Gloucester, Mass.....	I,	195
<i>Drawing by H. W. Elliott, 1882.</i>		

## THE COD FISHERY OF ALASKA.

36. Natives in boats fishing with hand-lines.....	I,	200
---	----	-----



## LIST OF PLATES TO SECTION V.

vii

## THE GILL-NET COD FISHERY.

	Vol.	Page.
37. Method of hanging cod gill-nets in Norway. (Explanation with plate) .....	I,	227, 228
From Bulletin U. S. Fish Commission, Vol. I. Drawing by Capt. J. W. Collins.		
38. FIG. 1. Method of attaching glass floats to top of nets. ....	I,	228
FIG. 2. Method of fastening sinkers to foot of nets. (Explanation on plate) .....	I,	223
From Bulletin U. S. Fish Commission, Vol. I. Drawing by Capt. J. W. Collins.		
39. Norwegian method of setting gill-nets at bottom. (Explanation on plate) .....	I,	228
From Bulletin U. S. Fish Commission, Vol. I. Drawing by Capt. J. W. Collins.		
40. Norwegian methods of setting nets to get position of fish. (Explanation on plate) .....	I,	228
From Bulletin U. S. Fish Commission, Vol. I. Drawing by Capt. J. W. Collins.		
41. Norwegian method of attaching stone anchors and buoy lines to end of gangs of nets. (Explanation on plate) .....	I,	228
From Bulletin U. S. Fish Commission, Vol. I. Drawing by Capt. J. W. Collins.		
42. Way in which cod gill-nets are set at the bottom on the east coast of Newfoundland. (Explanation on plate) .....	I,	230
From Bulletin U. S. Fish Commission, Vol. I. Drawing by Capt. J. W. Collins.		
43. The ordinary way in which cod gill-nets are set floating at Newfoundland. (Explanation on plate) .....	I,	230
From Bulletin U. S. Fish Commission, Vol. I. Drawing by Capt. J. W. Collins.		
44. Way in which cod gill-nets are set for underrunning in Ipswich Bay, Massachusetts. (Explanation on plate) .....	I,	232
From Bulletin U. S. Fish Commission, Vol. I. Drawing by Capt. J. W. Collins.		
45. Underrunning cod gill-nets in Ipswich Bay, Massachusetts. ....	I,	232
Drawing by H. W. Elliott and Capt. J. W. Collins.		

## THE INSHORE COD FISHERY.

46. Block Island boat and crew hand-lining for cod. ....		
Drawing by H. W. Elliott and Capt. J. W. Collins.		
47. Pink stern schooner and boats hand-line fishing off Cape Ann, Massachusetts. ....		
From photograph by T. W. Smillie.		

## THE HADDOCK FISHERY.

48. Baiting trawls on deck of Gloucester haddock schooner Mystic, Captain McKinnon. ....	I,	237
From photograph by T. W. Smillie.		
49. Baiting trawls at night in hold of haddock schooner .....	I,	237
Drawing by H. W. Elliott, 1882.		
50. Setting haddock trawls from schooner under sail; set at right angles to course of the vessel. ....	I,	238
Drawing by H. W. Elliott and Capt. J. W. Collins.		

## THE HAKE FISHERY.

51. Fishermen's dories on the rocks at Folly Cove, Cape Ann, Massachusetts. ....	I,	241
Drawing by H. W. Elliott.		
52. Fishermen in dory hauling trawl; a dogfish caught .....	I,	242
From photograph by T. W. Smillie.		
53. Overhauling trawls in fish-house at Rockport, Mass. ....	I,	242
Drawing by H. W. Elliott.		

## THE MACKEREL PURSE-SEINE FISHERY.

54. Mackerel schooner under full sail, bound out .....	I,	248
Drawing by H. W. Elliott and Capt. J. W. Collins.		
55. The cabin of mackerel schooner John D. Long of Gloucester, Mass. ....	I,	247
Drawing by H. W. Elliott.		
56. Deck plan of mackerel schooner. (Explanation on plate) .....	I,	248
Drawing by Capt. J. W. Collins.		
57. Seine boat; purse davit and blocks; oar-rests; purse weight and purse blocks; bow fittings. ....	I,	250
58. Seine boats in winter quarters at Gloucester, Mass. ....	I,	250
From photograph by T. W. Smillie.		
59. FIG. 1. Diagram showing the different sections of a purse-seine. ....	I,	252
FIG. 2. Diagram showing the form of a purse-seine when spread in the water. ....	I,	252
Drawings by Capt. J. W. Collins.		

	Vol.	Page.
60. Mackerel schooner cruising in Massachusetts Bay; lookout at foretop on the watch for schools .. From photograph by T. W. Smilie.	I,	255
61. Lookouts aloft on schooner on the watch for mackerel..... Drawing by H. W. Elliott and Capt. J. W. Collins.	I,	255
62. Mackerel seine-boat and crew "paying out the seine" Drawing by H. W. Elliott and Capt. J. W. Collins.	I,	256
63. Mackerel seine-boat and crew pursuing the seine..... Drawing by H. W. Elliott and Capt. J. W. Collins.	I,	256
64. Mackerel schooner with crew at work hauling mackerel from the purse-seine..... Drawing by H. W. Elliott and Capt. J. W. Collins.	I,	258
65. Mackerel schooner with pocket or spiller shipped at sea..... Drawing by H. W. Elliott and Capt. J. W. Collins.	I,	265
66. Mackerel schooner just arrived from cruise; crew dressing and salting the fish..... From photograph by T. W. Smilie.	I,	267
67. Culling and packing mackerel at Portland, Me..... From photograph by T. W. Smilie.	I,	267

## THE MACKEREL HOOK FISHERY.

68. Surf-fishing in boats for mackerel..... Drawing by H. W. Elliott and Capt. J. W. Collins.	I,	275
69. Mackerel jigs and jig molds. (Explanation on plate).....	I,	278
70. Jigging mackerel over the vessel's rail..... Drawing by H. W. Elliott and Capt. J. W. Collins.	I,	284
71. Gaffing mackerel over the vessel's rail..... Drawing by H. W. Elliott and Capt. J. W. Collins.	I,	279
72. FIG. 1. The old method of chopping mackerel bait.....	I,	279-283
FIG. 2. The modern mackerel bait-mill..... Drawings by H. W. Elliott and Capt. J. W. Collins.	I,	279-283
73. Throwing bait to toll mackerel alongside the vessel..... Drawing by H. W. Elliott and Capt. J. W. Collins.	I,	284
74. Deck scene on mackerel hand-line schooner; jigging mackerel, slatting in the barrel, throwing toll-bait..... Drawing by H. W. Elliott and Capt. J. W. Collins.	I,	284
75. Mackerel-packing on shipboard..... FIG. 1. Splitting, cleaning, and washing. FIG. 2. Pitching, salting, and plowing. Drawings by H. W. Elliott and Capt. J. W. Collins.	I,	287

## THE MACKEREL GILL-NET FISHERY.

76. Mackerel drag-nets set at night off coast of Maine..... Drawing by H. W. Elliott and Capt. J. W. Collins.	I,	294
77. Cape Cod mackerel drag-boat lying to at night..... From sketch by J. S. Ryder.	I,	294
78. Dory fishermen picking mackerel gill-nets..... From photograph by T. W. Smilie.	I,	294

## THE MACKEREL FISHERY—EARLY METHODS.

79. Old style Chebaeco boats drailing for mackerel..... Drawing by H. W. Elliott and Capt. J. W. Collins.	I,	299
80. Angling with poles for mackerel from an old Noank, Conn., sloop..... Drawing by H. W. Elliott and Capt. J. W. Collins.	I,	299

## STATISTICS OF THE MACKEREL FISHERY.

81. Diagram showing the catch of mackerel by citizens of Massachusetts between the years 1804 and 1881, inclusive..... From Report U. S. Fish Commission, Part IX, 1881.	I,	312
--	----	-----

LIST OF PLATES TO SECTION V.

ix

THE SWORDFISH FISHERY.

	Vol.	Page
82. Sword fishermen in position for action .....	I,	318
From Report U. S. Fish Commission, Part VIII, 1880.		
83. Methods of swordfish capture in the Mediterranean Sea.....	I,	318
From Report U. S. Fish Commission, Part VIII, 1880.		

THE MENHADEN FISHERY.

84. Map illustrating geographical distribution and periodical movements of the menhaden; also the locations of the fishing grounds and oil and guano factories in the year 1878. (No factories now in Maine; many in Chesapeake Bay).....	I,	331, 343
From Report U. S. Fish Commission, Part VI, 1878.		
85. Menhaden steamer Joseph Church approaching oil and guano factory at Tiverton, R. I.....	I,	334
From photograph by T. W. Smilie.		
86. Menhaden steamer William Floyd cruising for fish .....	I,	334
From sketch by Capt. B. F. Conklin.		
87. Lookouts at mast-head of menhaden steamer watching for schools of fish.....	I,	338
From sketch by J. S. Ryder.		
88. Fleet of menhaden steamers <i>en route</i> to fishing grounds on south side of Long Island, N. Y.....	I,	338
From sketch by Capt. B. F. Conklin.		
89. Fleet of menhaden steamers on the fishing grounds; seining crews at work .....	I,	338
From sketch by Capt. B. F. Conklin.		
90. Crew of menhaden steamer surrounding a school with purse-seine .....	I,	337-339
From sketch by Capt. B. F. Conklin.		
91. Pursing the seine around a school of menhaden .....	I,	337-339
From sketch by Capt. B. F. Conklin.		
92. Menhaden crew at work; pursing of the seine nearly completed.....	I,	339
From sketch by H. W. Elliott, 1878.		
93. School of menhaden surrounded with purse-seine and fish striking the net .....	I,	339
From sketch by Capt. B. F. Conklin.		
94. Bailing menhaden from purse-seine into steamer's hold.....	I,	337, 340
From sketch by J. S. Ryder.		
95. Menhaden steamer bailing in the catch .....	I,	340
From sketch by Capt. B. F. Conklin.		
96. Haul-seine fishing for menhaden at Long Island, 1790 to 1850. Setting the seine.....	I,	341, 368, 371
From sketch by Capt. B. F. Conklin.		
97. Haul-seine fishing for menhaden at Long Island, 1790 to 1850. Hauling the seine on the beach by horse-power .....	I,	341, 368, 371
From sketch by Capt. B. F. Conklin.		
98. Haul-seine fishing for menhaden at Long Island, 1790 to 1850. Taking out the fish.....	I,	341, 368, 371
From sketch by Capt. B. F. Conklin.		
99. Menhaden purse and mate boats and two carry-away boats starting for the fishing grounds....	I,	334, 368
From sketch by Capt. B. F. Conklin.		
100. Menhaden purse and mate boats .....	I,	334, 368
FIG. 1. Going down to the fish.		
FIG. 2. Working to windward of the fish.		
From sketches by Capt. B. F. Conklin.		
101. Purse and mate boats encircling a school of menhaden; carry-away boats in waiting .....	I,	334, 368
From sketch by Capt. B. F. Conklin.		
102. Menhaden boats and crew pursing the seine; the fish striking the net .....	I,	334, 368
From sketch by Capt. B. F. Conklin.		
103. Menhaden sloops cruising for fish. One of the sloops is for the crew to live on and to tow the seine-boats; the others to carry fish to the factory.....	I,	334, 368, 375, 376
From sketch by Capt. B. F. Conklin.		
104. Menhaden sloops and steamers in Gardiner's Bay, Long Island.....	I,	399
From sketch by Capt. B. F. Conklin.		
105. Menhaden carry-away sloops bailing in the catch.....	I,	376, 377
From sketch by Capt. B. F. Conklin.		
106. Menhaden fishermen signaling to shore-crews the approach of a school of fish .....	I,	367

	Vol.	Page.
107. Crew of menhaden schooner, in old style seine-boat, throwing the purse-seine .....	I,	336, 338
108. Carry-away boat with haul of menhaden on the way to oil factory .....	I,	373
From sketch by Capt. E. F. Conklin.		
109. Menhaden steamer discharging its catch at oil and guano factory, Tiverton, R. I. ....	I,	337
From photograph by T. W. Smillie.		
110. Gang of Portuguese in hold of menhaden steamer filling the hoisting tubs .....	I,	337
From photograph by T. W. Smillie.		
111. Fish pens on top floor of menhaden factory; the fish are led through a trough to the cooking tanks .....	I,	337
From photograph by T. W. Smillie.		
112. Menhaden steamer discharging its catch at oil and guano factory. Incline railway to carry fish to cooking tanks .....	I,	337
From sketch by Capt. B. F. Conklin.		
113. Menhaden floating factory. An old vessel fitted as an oil factory and moved from place to place near the fishing grounds .....	I,	345, 378
Drawing by H. L. Todd.		
114. Slivering menhaden for bait .....		
From Report U. S. Fish Commission, Part V, 1877.		
115. Menhaden oil and guano factory at Milford, Conn.; steamers unloading fish at the wharf; incline railway to carry fish to cooking tanks on upper floor of factory; oil tanks and storage sheds in foreground; platform for drying scrap in rear of factory, connected with building by elevated railway .....	I,	342
From a photograph.		
(Interiors of oil factories will be illustrated in Section on Preparation of Fishery Products.)		

## THE HERRING FISHERY AND SARDINE INDUSTRY.

116. Herring schooner bound for Wood Island, Maine; outfit of salt and barrels on deck .....	I,	426
From photograph by T. W. Smillie.		
117. Herring pinkey bound for the fishing grounds; nets hanging over bowsprit and stern; net dories on deck .....	I,	426
From photograph by T. W. Smillie.		
118. Torching at night for spurling or small herring in Ipswich Bay, Massachusetts .....	I,	428
From sketch by J. S. Ryder.		
119. Torching herring at night near Eastport, Me. ....	I,	429
From photograph by T. W. Smillie.		
120. Fishermen mending herring gill-nets at House Island, Casco Bay .....	I,	430
From photograph by T. W. Smillie.		
121. Irish fishermen of Boston picking their herring nets in Gloucester Harbor. The typical "Irish market boat" .....	I,	430
From photograph by T. W. Smillie.		
122. Cape Ann herring fishermen landing their gill-nets after a night's fishing .....	I,	430
From photograph by T. W. Smillie.		
123. Fishermen in quoddy boat hauling herring gill-nets .....	I,	430
Drawing by H. W. Elliott and Capt. J. W. Collins.		

## THE SMOKED HERRING INDUSTRY.

124. Boat landing; fish houses; herring smoke-house; fisherman's dwelling and farm .....	I,	476
From photograph by T. W. Smillie.		
125. Old style herring smoke-house (without roof ventilators) at Lubec, Me. ....	I,	476
From photograph by T. W. Smillie.		
126. Herring "horse" loaded with smoked fish on sticks .....	I,	478
From photograph by T. W. Smillie.		
127. Herring smoke-house at Eastport, Me.; smoke ventilators on roof; sticks of herring inside .....	I,	480
From photograph by T. W. Smillie.		

## THE SARDINE INDUSTRY.

128. Shore herring weir near Eastport, Me.; the common form of brush weir .....	I,	501
From photograph by T. W. Smillie.		
129. Bar herring weir near Eastport, Me.; escape of fish prevented by receding tide .....	I,	500
From photograph by T. W. Smillie.		

LIST OF PLATES TO SECTION V.

xi

	Vol.	Page.
130. Channel herring weir near Eastport, Me. ; controls channel between islands .....	I,	501
From photograph by T. W. Smillie.		
131. Section of ballasted weir near Eastport, Me. ; for rocky bottom.....	I,	502
From photograph by T. W. Smillie.		
132. Fishing a herring weir at low tide, near Eastport, Me.....	I,	503
From photograph by T. W. Smillie.		
133. General view of sardine cannery at Eastport, Me.....	I,	508
From photograph by T. W. Smillie.		
134. View of sardine cannery at low tide, showing the employés at work .....	I,	508
From photograph by T. W. Smillie.		
135. Herring boat landing fish at a sardine cannery, Eastport, Me.....	I,	509
From photograph by T. W. Smillie.		
136. Sardine steamer for collecting herring and towing weir boats.....	I,	510
From photograph by T. W. Smillie.		
137. Children at sardine cannery cutting off the heads and tails and cleaning small herring for canning .....	I,	510
From photograph by T. W. Smillie.		
138. Washing, draining, and flaking herring at sardine cannery, Eastport, Me.....	I,	512
From photograph by T. W. Smillie.		
139. Spreading herring on flakes for drying in the sun or in an oven .....	I,	511
From photograph by T. W. Smillie.		
140. Herring drying on flakes in the sun ; landing, cleaning, washing, &c., at sardine cannery, Eastport, Me.....	I,	513
From photograph by T. W. Smillie.		
141. Fish-drying frames on roof at sardine cannery, Eastport, Me.....	I,	512
From photograph by T. W. Smillie.		
142. Frying room in sardine cannery, Eastport, Me. ; herring frying in pans of oil .....	I,	514
From photograph by T. W. Smillie.		
143. Packing room at sardine cannery, Eastport, Me. ; packing herring-sardines in tin boxes .....	I,	515
From photograph by T. W. Smillie.		
144. Soldering room at sardine cannery, Eastport, Me. ; solderers sealing the cans.....	I,	516
From photograph by T. W. Smillie.		
145. Bathing room at sardine cannery, Eastport, Me. ; bathing vats at the left ; men at right venting cans .....	I,	517
From photograph by T. W. Smillie.		
146. Making sardine cans at Eastport, Me.....	I,	518
From photograph by T. W. Smillie.		

THE SPANISH MACKEREL FISHERY.

147. Methods of setting Spanish mackerel gill-nets.....	I,	546
FIG. 1. "Straight set."		
FIG. 2. Circle set.		
FIG. 3. Crooked set.		
FIG. 4. "Hook set."		
FIG. 5. "T set."		
FIG. 6. "Square set."		
FIG. 7. "Triangle set."		
FIG. 8. "Harpoon set."		
From Report U. S. Fish Commission, Part VIII, 1880.		
148. Chesapeake Bay Spanish mackerel pound-net .....	I,	548
From Report U. S. Fish Commission, Part VIII, 1880.		

THE MULLET FISHERY.

149. Camp of mullet fishermen, North Carolina.....	I,	562
From a photograph.		

THE POUND-NET FISHERIES OF THE ATLANTIC STATES.

150. Diagram of pound-net at Bald Head, Maine. (By Capt. J. W. Collins).....	I,	598
151. Diagram of pound-net at Small Point, Maine. (By Capt. J. W. Collins) .....	I,	598

	Vol.	Page.
152. FIG. 1. Diagram of pound-net at Wood's Holl, Mass .....	I,	601
FIG. 2. Diagram of heart or pound net as set in Rhode Island .....	I,	604
FIG. 3. Diagram of slat weir at East Dennis, Mass.....	I,	599
From Report U. S. Fish Commission, Part II, 1872-'73.		
153. FIG. 1. Diagram of pound-net at Waquoit, Mass .....	I,	601
FIG. 2. Diagram of heart or pound net at Quisset Harbor, Massachusetts.....	I,	601
From Report U. S. Fish Commission, Part II, 1872-'73.		

## THE RIVER FISHERIES OF THE ATLANTIC STATES.

154. Fishing with back and square traps in the Savannah River.....	I,	620
Drawing by H. W. Elliott.		
155. Shad gill-nets in the Edisto River, South Carolina.....	I,	623
Drawing by H. W. Elliott.		
156. Fish-nets in the Pedee River .....	I,	624
From a photograph.		
157. A sturgeon camp on Winyah Bay, South Carolina; catching sturgeon in gill-nets; the pound for keeping fish alive; unloading; saving roe for caviare.....	I,	625
Drawing by H. W. Elliott.		
158. Drag-net fishing in the Neuse River, North Carolina; "footing up the net" .....	I,	628
Drawing by H. W. Elliott.		
159. Skim-net fishing for shad in the Neuse River, North Carolina.....	I,	629
Drawing by H. W. Elliott.		
160. Haul-seine fishing at Sutton Beach, Albemarle Sound, North Carolina; boating the seine .....	I,	636
From a photograph.		
161. Haul-seine fishing at Sutton Beach, Albemarle Sound, North Carolina; a large haul of alewives.	I,	636
From a photograph.		
162. Shad-fishing in Albemarle Sound; laying out the seine.....	I,	636
Drawing by H. W. Elliott.		
163. Shad-fishing at night on the Susquehanna River; laying out the gill-net.....	I,	652
From a photograph.		
164. Diagram of salmon weirs in Penobscot River, Maine.....	I,	680
From Report U. S. Fish Commission, Part II, 1872-'73.		
165. Plan of salmon-net, Penobscot Bay, Maine .....	I,	682
From Report U. S. Fish Commission, Part II, 1872-'73.		
166. Ideal perspective of salmon-net in Penobscot Bay, Maine.....	I,	682
From Report U. S. Fish Commission, Part II, 1872-'73.		
167. Diagram of shad weir, Kennebec River, Maine. (Explanation on page opposite plate).....	I,	684
168. Bag-net fishing for smelts under the ice, Penobscot River, Maine. (Full explanation on page opposite plate) .....	I,	691
From sketch by C. G. Atkins.		

## THE PACIFIC COAST SALMON FISHERY.

169. Salmon cannery at Astoria, Oreg.....	I,	745
From a photograph.		

## THE FISHERIES OF THE GREAT LAKES.

170. Kelley's pound-net near Carpenter's Point, Lake Erie, for capture of whitefish, herring, &c. (For description of parts see plate).....	I,	758
Drawing by H. W. Elliott.		
171. Lifting the pot at Kelley's pound-net, Lake Erie.....	I,	760
Drawing by H. W. Elliott.		
172. Green Bay pound-net off Ingersoll's Fishery .....	I,	758
Drawing by L. Kumlien.		
173. "Driving the pound." Stake-boat and crew off Marblehead, Lake Erie, driving stakes for pound-net. At close of season the other end of the same boat pulls the stakes .....	I,	760
Drawing by H. W. Elliott.		
174. Deck plan of stake-boat. Stake-puller of Lake Erie. (For description of parts see plate).....	I,	760
175. Pound-net at Detroit River.....	I,	758
From sketch by L. Kumlien.		
176. Bailing out the pot of pound-net at Detroit River.....	I,	758
From sketch by L. Kumlien.		

LIST OF PLATES TO SECTION V.

xiii

	Vol.	Page.
177. Camp at South Manitou Island, Lake Michigan. Fishing-boats; gill-nets on reel; shanty for cleaning fish .....	I,	762
From a photograph.		
178. Gill-net drying on reel .....	I,	764
From a photograph.		
179. Type of fishermen's summer house. Seine shed, tarring-box annexed .....	I,	765
Drawing by H. W. Elliott, 1882.		
180. Hauling in herring-seine at Herbert's Fishery, Detroit River. Inclosure for keeping fish alive..	I,	766
Sketch by L. Kumlien.		
181. Pond fishery, Detroit River; inclosure for keeping fish alive .....	I,	766
Photograph by U. S. Fish Commission.		
182. Overhauling the seine at Grassy Island Fishery, Detroit River.....	I,	766
Photograph by U. S. Fish Commission.		

THE WHALE FISHERY.

183. Map of the world on Mercator's projection, showing the extent and distribution of the present and abandoned whaling grounds. (Prepared by A. Howard Clark in 1880).....	II,	7-23
184. FIG. 1. The sperm whale ( <i>Physeter macrocephalus</i> ). FIG. 2. The California gray whale ( <i>Rhachianectes glaucus</i> ). FIG. 3. The North Pacific humpback whale ( <i>Megaptera renabillis</i> ). FIG. 4. The sulphur-bottom whale ( <i>Sibbaldius sulfwens</i> ). FIG. 5. The finback or Oregon finner ( <i>Balaenoptera velifera</i> ). FIG. 6. The Pacific right whale ( <i>Eubalaena cullamach</i> ). FIG. 7. The bowhead whale ( <i>Balana mysticetus</i> ). From Report U. S. Fish Commission, 1876. Natural History in Section I of this report.		
185. Whaling vessels fitting out at New Bedford wharves.....	II,	232
From photograph by T. W. Smillie.		
186. Whaling schooner Amelia, of New Bedford, Mass.....	II,	232
Drawing by C. S. Raleigh.		
187. Steam whaling-bark Mary & Helen, of New Bedford, Mass. (afterwards the Rodgers, of the Jeanette search expedition) .....	II,	236
Drawing by C. S. Raleigh.		
188. Deck plan and side and interior plan of whaling-schooner Amelia, of New Bedford, Mass. (Explanation on page opposite plate).....	II,	234
Drawings by C. S. Raleigh.		
189. Deck plan and side and interior plan of whaling-bark Alice Knowles, of New Bedford, Mass. (Explanation on page opposite plate) .....	II,	234
Drawings by C. S. Raleigh.		
190. Starboard quarter of a whale-ship, showing the manner of transporting the captain's boat and the spare boats. (Explanation on page opposite plate) .....	II,	243, 244
191. Deck view of whale-boat equipped with apparatus of capture and boat gear. (Explanation on page opposite plate).....	II,	241, 258
Drawing by C. S. Raleigh.		
192. Side and interior plan of whale-boat equipped with apparatus of capture, &c. (Explanation on page opposite plate) .....	II,	241, 258
Drawing by C. S. Raleigh.		
193. Articles of whale-boat gear.....	II,	240, 252
FIG. 1. Lantern keg containing matches, bread, &c.		
FIG. 2. Boat compass.		
FIG. 3. Water keg.		
FIG. 4. Piggin for bailing water.		
FIG. 5. Waif for signaling.		
FIG. 6. Tub oar crotch.		
FIG. 7. Double oar-lock.		
FIG. 8. Large line in line-tub.		
FIG. 9. Knife to cut line when foul.		
FIG. 10. Row-lock.		
FIG. 11. Hatchet to cut line when foul.		
FIG. 12. Grapnel to catch line.		
FIG. 13. Drag or drug to retard whale.		
FIG. 14. Canvas nipper to protect hands from running line.		

	Vol.	Page.
194. Whalemens harpoons.....	II,	250
FIG. 1. Improved harpoon or toggle-iron now in general use.		
FIGS. 2, 3. First form of toggle-iron made by Lewis Temple.		
FIG. 4. One-flued harpoon with hinged toggle.		
FIG. 5. One-flued harpoon.		
FIG. 6. Two-flued harpoon.		
FIG. 7. Toggle-iron invented by Provincetown whalerman; not in use.		
195. English harpoons.....	II,	250
FIG. 1. Old-style hand-harpoon; now little used.		
FIG. 2. Hand-harpoon in general use about 1857.		
FIG. 3. Hand-harpoon now in general use on Scotch whalers. Drawings by Capt. William Adams, Dundee, Scotland.		
196. FIG. 1. English harpoon-gun and gun-harpoon now in use on Scotch whalers.....	II,	252
FIG. 2. An early form of English whaling-gun.....	II,	252
FIGS. 3, 4, 5. Mason and Cunningham mounting boat-gun; a recent invention. (Explanation with plate).....	II,	252
197. FIG. 1. Pierce and Cunningham darting-gun; a combined harpoon and lance used largely by Arctic whalemens. (Explanation with plate).....	II,	254
FIG. 2. Cunningham and Cogan gun; length, 33 inches; weight, 27 pounds; used by Arctic steam whalers with bomb lance.....	II,	253
FIG. 3. Brand muzzle-loading whaling-gun and bomb lance.....	II,	253, 254, 255
198. FIGS. 1, 2, 3, 4. Pierce bomb-lance. (Explanation on page opposite plate).....	II,	254, 267
FIG. 5. Pierce and Eggers breech-loading gun. (Explanation on page opposite plate).....	II,	253, 267
199. Whaling rocket. (Explanation on page opposite plate).....	II,	254
200. Boat fastened to whale by harpoon and line; killing the whale with bomb lance.....	II,	262, 267
From painting by J. S. Ryder.		
201. Natives harpooning the beluga, or white whale, at Cook's Inlet, Alaska.....	II,	61
Drawing by H. W. Elliott, 1883.		
202. Alouts planting glass, obsidian, and jade darts in a school of humpback whales at Akoon Island, Bering Sea.....	II,	61, 62
Drawing by H. W. Elliott, 1883.		
203. Makah Indians whaling at entrance to Fuca Straits.....	II,	62
Drawing by H. W. Elliott, 1883.		
204. Cutting in the bowhead and sperm whales. (Explanation on page opposite plate).....	II,	277, 286
Drawings by Capt. C. M. Scammon and Capt. W. M. Barnes.		
205. FIG. 1. Boat spade to stop running whale.....	II,	264
FIG. 2. Narrow cutting spade or thin boat spade.....	II,	281
FIG. 3. Flat or round shank spade.....	II,	281
FIG. 4. Cutting spade for scarfing blubber.....	II,	281
FIG. 5. Cutting spade for leaning up.....	II,	281
FIG. 6. Half-round spade.....	II,	281
206. Cutting blocks and tackle. (Explanation on page opposite plate).....	II,	277-281
207. A ship on the northwest coast of America cutting in her last right whale.....	II,	277
Drawing by H. W. Elliott from a French lithograph designed by B. Russell, of New Bedford.		
208. "Bailing in the case" of a sperm whale.....	II,	277
Drawing by H. W. Elliott from a French lithograph designed by B. Russell, of New Bedford.		
209. FIG. 1. Blubber mincing-knife.		
FIG. 2. Boarding-knife.		
FIG. 3. Monkey-belt.		
FIG. 4. Wooden toggle.		
FIG. 5. Chain-strap.		
FIG. 6. Throat-chain.		
FIG. 7. Fin toggle.		
FIG. 8. Head-strap.		
FIG. 9. Blubber-hook.		
210. Whale-ships at New Bedford wharf; ship hove down for repairs; oil-casks.....	II,	289, 290
From photograph by U. S. Fish Commission.		
<b>THE BLACKFISH AND PORPOISE FISHERY.</b>		
211. Capture of a school of blackfish in Cape Cod Bay.....	II,	295, 307
Drawing by H. W. Elliott from a sketch by J. S. Ryder.		



LIST OF PLATES TO SECTION V.

XV

	Vol.	Page.
212. Indian porpoise hunters of Passamaquoddy Bay. Canoe, rifle, and lance for capture of porpoise. From photograph by T. W. Smillie.	II,	308
213. Passamaquoddy Bay Indians lancing and securing a porpoise..... From photograph by T. W. Smillie.	II,	308

THE PACIFIC WALRUS FISHERY.

214. Innuits of Saint Lawrence Island, Alaska, surprising and harpooning a herd of walruses..... Drawing by H. W. Elliott.	II,	313
215. The walrus "coup." Eskimo lancing the exhausted walrus, Saint Lawrence Island, Bering Sea. Mahlemut dresses, bidarka, baidar, &c., of Alaska..... Drawing by H. W. Elliott.	II,	313
216. Innuits of Saint Lawrence Island, Alaska, hoisting a walrus..... Drawing by H. W. Elliott.	II,	313

THE FUR-SEAL INDUSTRY OF ALASKA.

217. Map of Saint Paul's Island, Pribylov Group..... Surveyed and drawn, April, 1873, to July, 1874, by Henry W. Elliott.	II,	322
218. Map of Saint George Island, Pribylov Group..... Surveyed and drawn, April, 1873, to July, 1874, by H. W. Elliott.	II,	322
219. Profiles of the east coast of Saint Paul's Island..... Drawing by H. W. Elliott.	II,	322, 336
220. Ordinary attire of men on the killing ground and of women and young children in the village. Drawing by H. W. Elliott.	II,	320
221. The north shore of Saint Paul's Island, looking W.S.W. from the summit of Hutchinson's Hill.. Drawing by H. W. Elliott.	II,	336
222. The North Rookery, looking west to Starry Ateel, Saint George Island, village of Saint George. Drawing by H. W. Elliott.	II,	346
223. Natives selecting a "drive." View over hauling grounds of "holluschickie" or bachelor seals at English Bay, looking west from Tolstoi sand-dunes..... Drawing by H. W. Elliott.	II,	363
224. Natives driving the "holluschickie." The drove passing over the lagoon flats to the killing grounds, under the village hill, Saint Paul's Island..... Drawing by H. W. Elliott.	II,	363
225. The killing gang at work. Method of slaughtering fur-seals on the grounds near the village, Saint Paul's Island..... Drawing by H. W. Elliott.	II,	365
226. Preparing fur-seal-skins for shipment..... FIG. 1. Interior of salt-house, Saint Paul's Island; natives salting and assorting the pelts. FIG. 2. The flensed carcass of a fur-seal and the skin as taken therefrom. FIG. 3. A bundle of skins ready for shipment.	II,	369

THE ANTARCTIC SEA-ELEPHANT FISHERY.

227. Sketch map of Herd's Island, Antarctic Ocean. Lat. 53° 10' S., Long. 73° 30' E.....	II,	419
228. Working sea-elephants at northeast point, Herd's Island..... Drawing by H. W. Elliott after Capt. H. C. Chester.	II,	419, 435
229. Stripping sea-elephant blubber and rolling it in barrels to try-works; southwest beach, Herd's Island..... Drawing by H. W. Elliott after Capt. H. C. Chester.	II,	419, 435

THE SEA-LION HUNT ON PRIBYLOV ISLANDS, ALASKA.

230. Natives capturing the sea-lion; springing the alarm..... Drawing by H. W. Elliott, 1873.	II,	468
231. Shooting the old males; spearing the surround; the drive..... Drawing by H. W. Elliott, 1872.	II,	468, 469, 471
232. Natives corralling sea-lions at the Barrabara, under Cross Hill, northeast point Saint Paul's Island..... Drawing by H. W. Elliott.	II,	469
233. Oil-pouches of sea-lion stomach; seal meat frame; bidarrah covered with sea-lion skins; sealer's houses..... Drawing by H. W. Elliott.	II,	471, 473

THE SEA-OTTER FISHERY OF ALASKA.		Vol.	Page.
234. Aleuts sea-otter hunting south of Saanuk Island; the bidarkies waiting for the otter to rise again .....	Drawing by H. W. Elliott.	II,	490
THE TURTLE FISHERY.			
235. Diving for loggerhead turtle; Morehead City, N. C. ....	Drawing by H. W. Elliott, 1883.	II,	495
THE OYSTER INDUSTRY.			
236. Oyster dredging steamer at work in Long Island Sound.....		II,	522, 535
237. Chesapeake Bay oyster dredges .....	From specimens in U. S. National Museum.	II,	523
238. Oyster tongs and rippers .....		II,	551
239. FIG. 1. Inclosed dock for oyster vessels at Perth Amboy, N. J. ....		II,	546
FIG. 2. "The Creek" at Keyport, N. J., with oyster boats, skiffs, and scows .....	Drawings by Ernest Ingersoll.	II,	546
240. A Lake's Bay shipping-house and "platform" for freshening oysters, Smith's Landing, Lake's Bay, New Jersey .....	Drawing by Ernest Ingersoll.	II,	546
241. Oyster-barges at foot of West Tenth street, North River, New York City .....	Drawing by Ernest Ingersoll.	II,	555
242. Opening or shucking oysters in Baltimore packing house .....	From a photograph.	II,	560
243. Baltimore oyster-shucking trough. Oyster knives of diverse patterns, used in New England, New York, and the Chesapeake region.....		II,	559
THE CLAM INDUSTRY.			
244. Clam diggers' boats and shucking-houses at Essex, Mass.....	From photograph by T. W. Smillie.	II,	585
245. Opening or shucking clams at Essex, Mass .....	From photograph by T. W. Smillie.	II,	585
THE CRAB FISHERY.			
246. Negroes trawling for crabs on the Virginia and North Carolina coasts.....	Drawing by H. W. Elliott.	II,	633
THE LOBSTER FISHERY.			
247. Dory fishermen hauling lobster pots off Cape Ann, Massachusetts .....	From photograph by T. W. Smillie.	II,	666, 677, 773
248. Lobster fishing-boats of Bristol, Me .....	Drawing by H. W. Elliott and Capt. J. W. Collins.	II,	669, 677, 759
249. Lobster Cove at Lanesville, Cape Ann, Massachusetts, showing fishermen's boat-houses and gear.	From photograph by T. W. Smillie.	II,	666, 773
250. Summer village of lobster fishermen at No Man's Land, Massachusetts .....	Drawing by H. W. Elliott, 1882.	II,	781
251. Lobster fishermen's gear at No Man's Land, Massachusetts. (Explanation on plate).....	Drawing by H. W. Elliott.	II,	665, 672, 781
252. Lobster-bailing apparatus at Portland, Me.....	From photograph by T. W. Smillie.	II,	681
THE FLORIDA SPONGE INDUSTRY.			
253. Sponges as landed by the fishermen at Key West, Fla., and ready for sale .....	From a photograph.	II,	826
254. Sponge-loft at Key West, Fla .....	From a photograph.	II,	828
255. Sorting, trimming, and baling sponges at Key West, Fla.....		II,	828

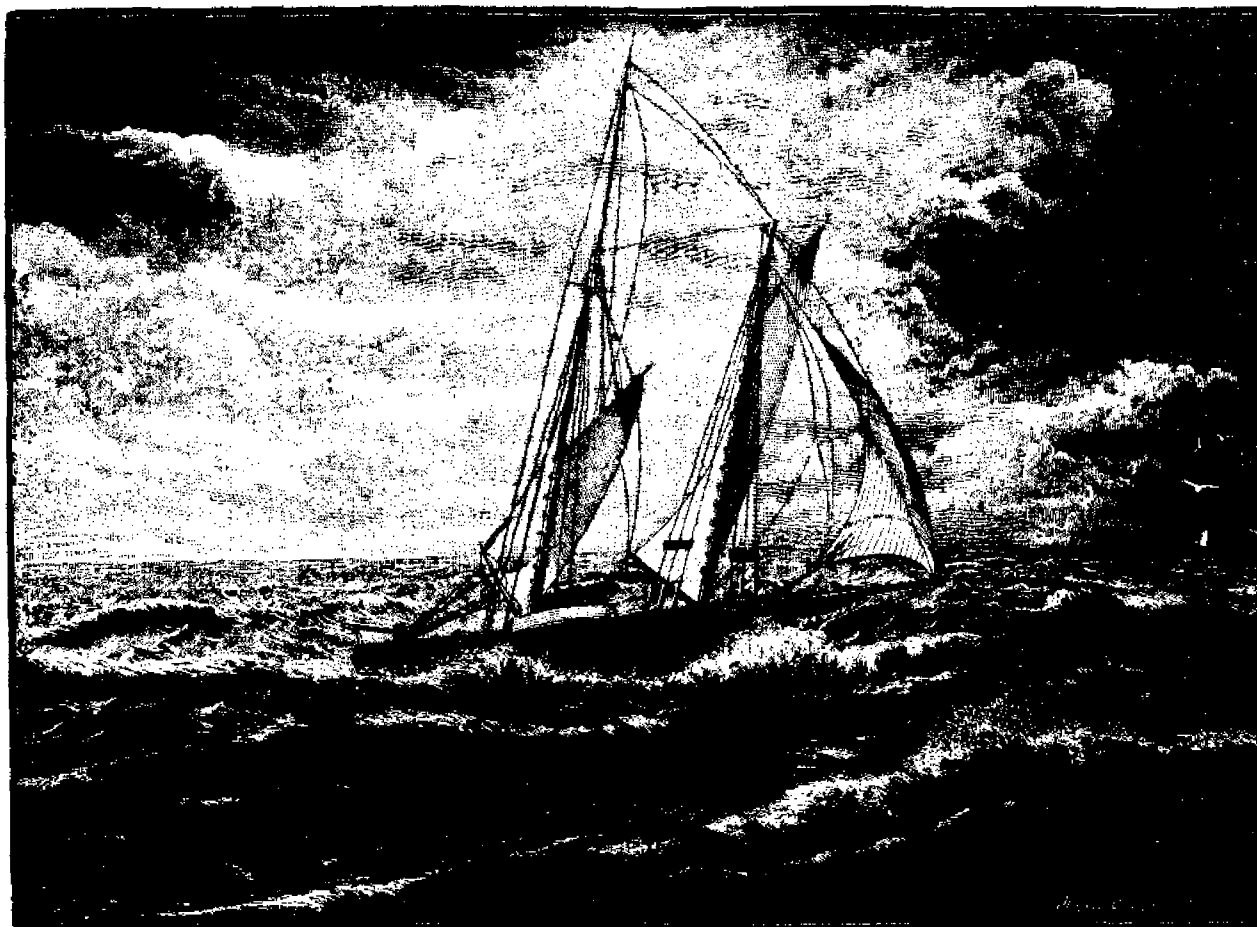

### THE FRESH HALIBUT FISHERY.

Halibut schooner under jib, foresail, and double-reefed mainsail. Nests of dories lashed on deck amidships. Rigged for fall and winter fishing. (Sect. v, vol. 1, p. 7.)

Drawing by Capt. J. W. Collins.

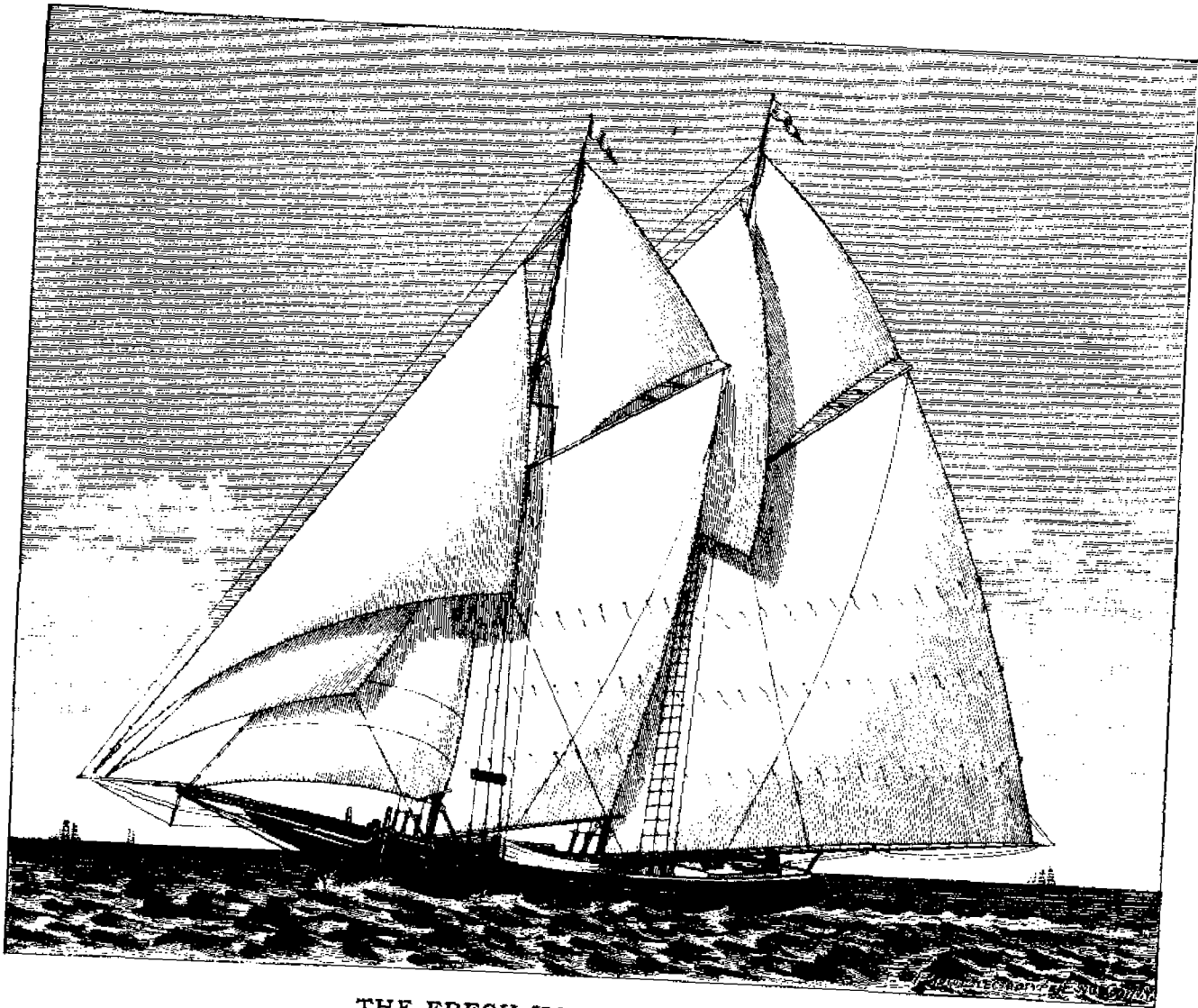

**THE FRESH HALIBUT FISHERY.**

Halibut schooner in summer rig: Two top-masts up and all sails set. In winter the foretop-mast and jib-boom are not carried.  
(Sect. v. vol. i, p. 7.)

Drawing by Capt. J. W. Collins.

## Plate 3.

### SECTIONAL DRAWING OF HALIBUT SCHOONER, SHOWING PORT SIDE OF VESSEL.

FIG. 1.—1, Hawse-hole; C, knight-heads. 2, Inside part or "heel" of bowsprit. 3, End view of the middle part of the windlass, between the patent and windlass-bit on starboard side, showing position of the whelps on windlass. 4, Pawl-bit. 5, Position of the windlass beam. 6, Position of jib-sheet traveler. 7, Foremast. 8, Forward companion-way. 9, Fore-hatch, for hoisting in and out water and provision barrels; in moderate weather it is covered with a grating and serves the purpose of ventilating the forehold and forecabin. 10, The forehold, where the stores and water are kept; the water (28 to 30 barrels) is stowed in different ways to suit the ideas of the cook or skipper, but generally on the starboard side—oftentimes two large casks are carried amidships—and a pantry is built on the port side, where the "heavy stores" (flour, beef, &c.) are stowed on the head, that is, such as are open and being used, while the "small stores" (butter, lard, sugar, &c.) are kept in firkins, half-barrels, &c., and secured from being upset by setting in places built for them as shown in the drawing. A coal-pen is built between the pantry and forward bulkhead to the ice-house. The coal-pen is sometimes built on the starboard side next to the forecabin bulkhead. 11, Forecabin steps. 12, Cupboard, from deck to locker; there is another of the same size on the starboard side, just forward of the foremast. 13, After section of the table with the leaf turned up; this also turns back against the mast, the leaves folding alongside of the mast. 14, Locker on port side. 15, Forecabin floor. 16, Forward section of table; this is stationary, the forward end fastening to the pawl-bit, and the after end supported by an upright standard. 17, 18, 19, 20, 21, and 22, Positions of the upper and lower berths on port side; No. 22, being in the fore-peak, is small, and is not used for sleeping purposes, but is utilized for the storage of lanterns, kerosene-cans, &c.; there are only two rows of sleeping bunks on the starboard side; the berths abreast of the after row are used by the cook as lockers for his cooking utensils, &c. 23, Position of cook-stove (always carried on starboard side). 24, Pawl-bit, under deck. 25, Forward pen in the ice-house, with pen-boards up, or shipped in place. 26, Forward bulkhead to ice-house, built of double boards, with tarred paper between, from side to side of vessel. 27, Stanchion and partition between the forward and second pen. 28, Second pen, showing how the ice is stowed. 29, Shows how halibut are iced in a pen, always white side up, and lying upon each other, so that they are slanting instead of flat in the pen; one-half of the tier is stowed head towards the side of the vessel, and the other half out, as shown in the drawing, both forming what is called a tier. 30, After pen in forward ice-house. 31, Bulkhead between the forward and after ice-house, built same as the forward one. 32, Pumps. 33, Ballast under the plank floor of the ice-house; this plank floor is laid on sleepers, which extend from side to side of the hold; these sleepers are, or ought to be, supported by stanchions under them. 34, Forward pen in after ice-house. 35, After pen. 36, Salt-pen; this pen is larger than this in some vessels. 37, Checker-plank. 38, Main hatch. 39, Checker-plank. 40, Break of the quarter-deck. 41, Mainmast. 42, After-hatch; (a) skylight on top of house; (B) stovepipe. 43, After, or cabin, companion-way. 44, Wheel. 45, Wheel-box. 46, Taffrail. 47, Vacant place aft of cabin, under deck; used for the storage of gear, rope, &c. 48, Cabin stairs, called "steps" by fishermen. 49, After berth. 50, Partition between the berths. 51, Forward berth. 52, Locker, or seat, going around the cabin. 53, Stove. 54, Position of trap-door in the cabin floor, by which the coal is reached.

### DECK PLAN OF HALIBUT SCHOONER.

Fig. 2.—1, Bowsprit. 2, Pawl-bit. 3, Starboard windlass-bit. 4, Port windlass-bit. 5, Windlass. 6, Jib-sheet traveler. 7, Foremast. 8, Port cable tier. 9, Starboard cable tier. 10, Forecabin companion slide. 11, Stovepipe funnel. 12, Forehatch, showing grating. 13, Main hatch. 14, "Break" of quarter deck, or grub beam. 15, Mainmast. 16, Starboard pump. 17, Port pump. 18, After hatch. 19, Trunk, or cabin house. 20, Stove funnel. 21, Skylight. 22, Companion slide. 23, 24, 25, 26, Bait planks around top of house. 27, Wheel box. 28, Wheel. 29, 30, Bit heads, for belaying main sheet, &c., to. 31, Taffrail. a, a, a, a, a, a, &c., Checker planks. b, b, &c., checkers. c, c, dotted lines showing position of dories when on deck.

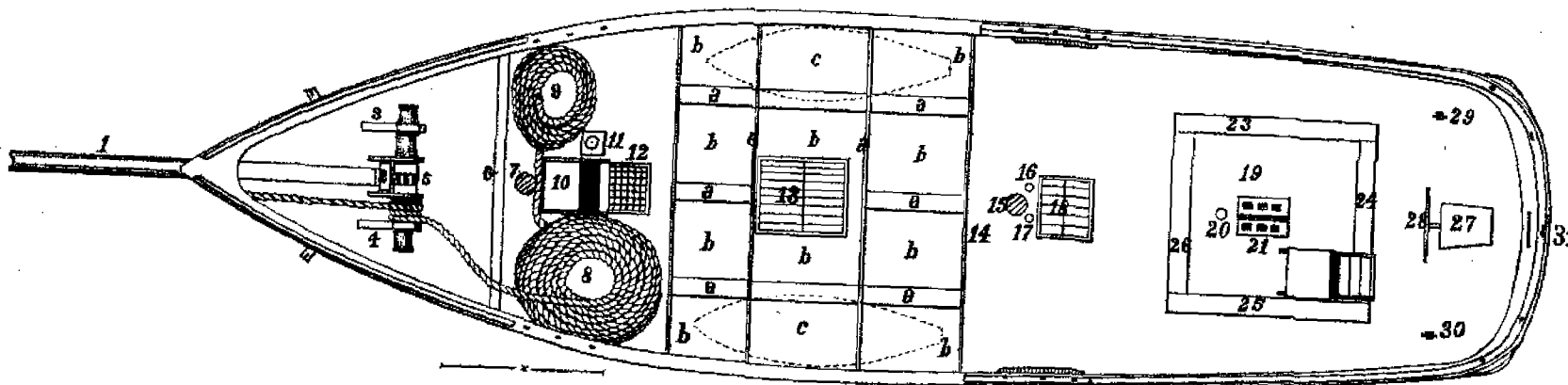
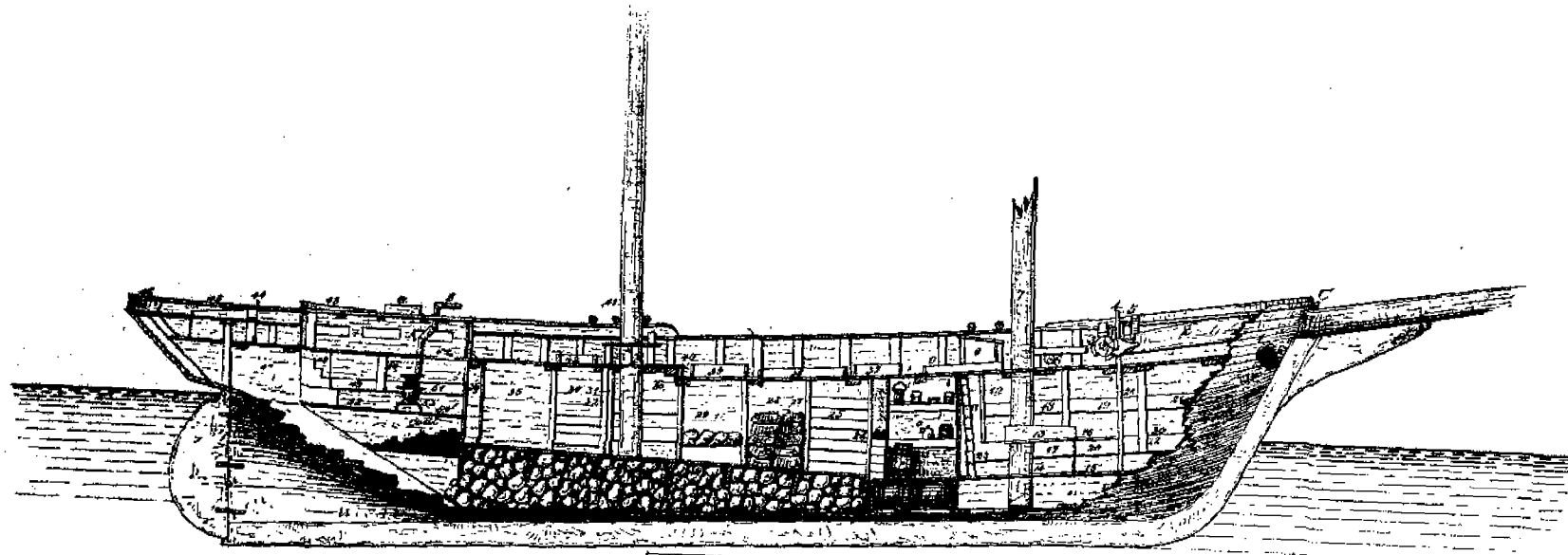

**THE FRESH HALIBUT FISHERY.**

Sectional plan and deck plan of halibut schooner. (Sect. v, vol. i, pp. 7-9.)

Drawings by Capt. J. W. Collins.

## Plate 4.

GEORGE'S WELL SMACK—1836 TO 1847.

1, Gammon lashing. 2, Small hatch for entrance to fore-castle. 3, Steps. 4, Pall-bit. 5, Windlass. 6, Forward pump. 7, Fore-castle bulkhead. 8, Main hatch or entrance to well. 9, Water line in well. 10, Well-room. The dotted lines show that the well was sometimes made larger, extending aft of the mainmast, but as it was considered dangerous to have the mast rest on the well-deck, few adopted this plan. 11, Forward bulkhead of well. 12, After bulkhead of well. 14, After hold. 15, After pump. 16, After hatch. 17, Break of the quarter-deck. 18, Quarter rail. 19, Salt pen. 20, Cabin companion-way. 21, Steps. 22, Berths. 23, Table. 24, Tiller. 25, Rudder head.

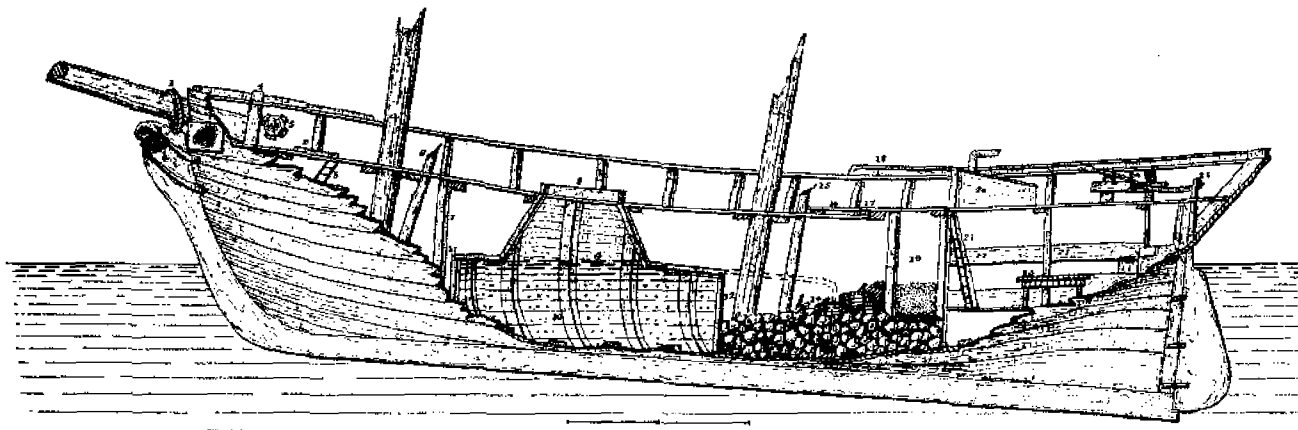

**THE FRESH HALIBUT FISHERY.**

Sectional plan of well-smack employed in fresh halibut fishery on George's Bank, 1836 to 1847. (Sect. v, vol. i, p. 41.)

Drawing by Capt. J. W. Collins.



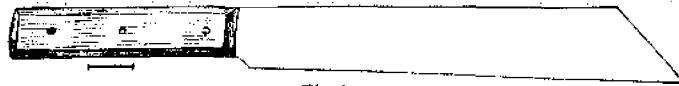

Fig. 1.

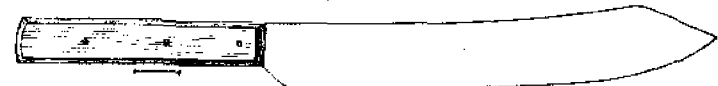

Fig. 2.

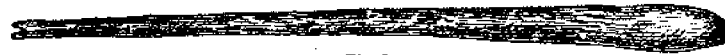

Fig. 3.

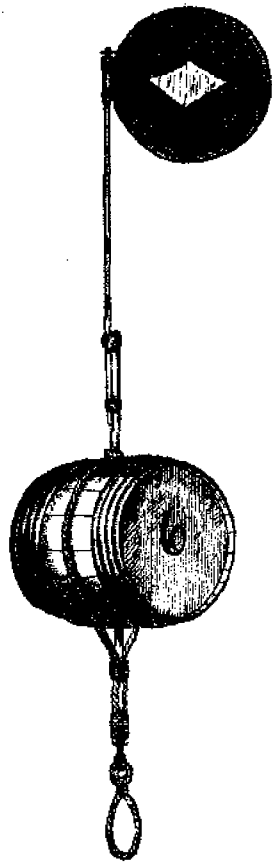

Fig. 6.



Fig. 4.



Fig. 5.

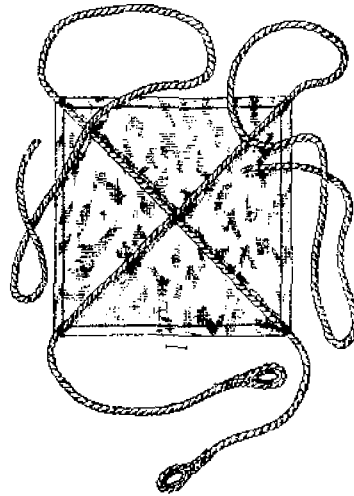

Fig. 7.



Fig. 8.

### THE FRESH HALIBUT FISHERY.

FIG. 1. Bait-chopper. (Sect. v, vol. i, p. 12.)

FIG. 2. Bait-slivering knife. (Sect. v, vol. i, p. 12.)

FIG. 3. Halibut-killer and gob-stick. (Sect. v, vol. i, p. 17.)

FIG. 4. Woolen hand-nipper. (Sect. v, vol. i, pp. 10, 94.)

FIG. 5. Halibut-gaff. (Sect. v, vol. i, p. 17.)

FIG. 6. Trawl buoy and black ball. (Sect. v, vol. i, p. 11.)

FIG. 7. Canvas skate for trawl. (Sect. v, vol. i, p. 11.)

FIG. 8. Dory scoop. (Sect. v, vol. i, p. 10.)

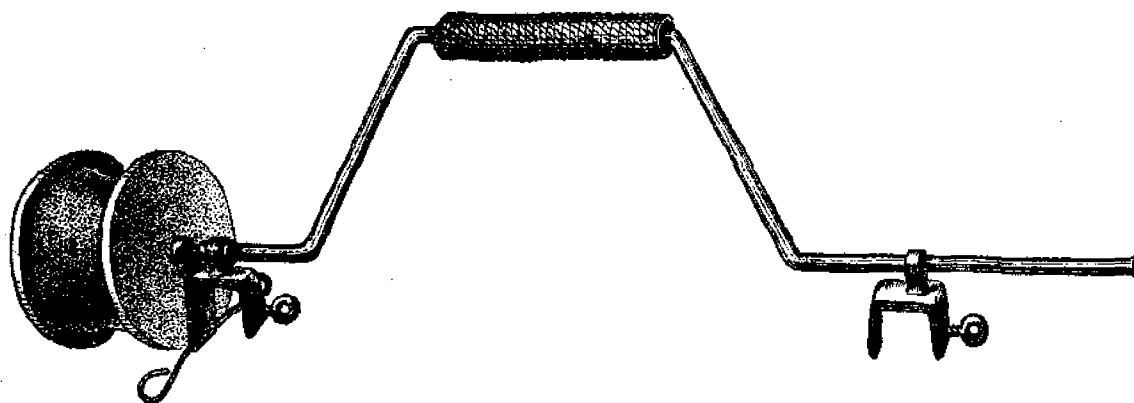

Fig. 1.

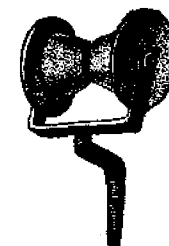

Fig. 3.

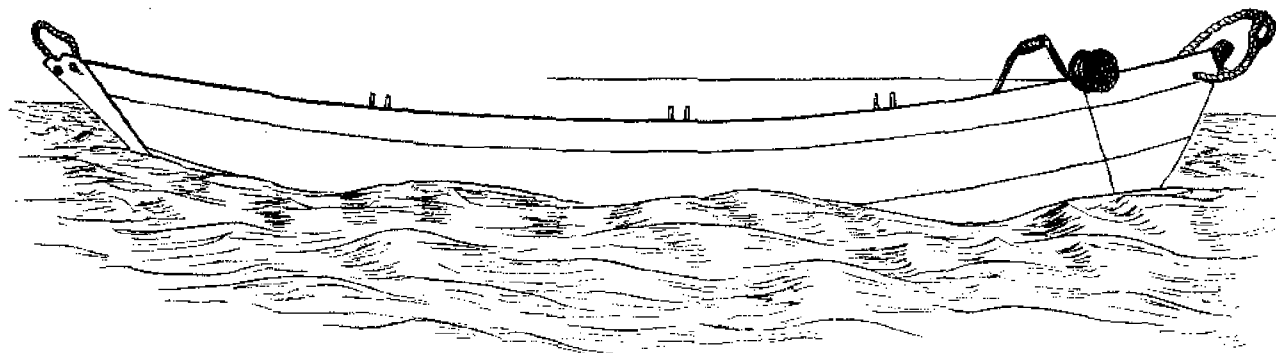

Fig. 2.

### THE FRESH HALIBUT FISHERY.

FIG. 1. Hardy-gurdy to haul trawls in deep water. (Sect. v, vol. i, pp. 10, 11, 16.)

FIG. 2. Dory, showing mode of attaching and using hardy-gurdy. (Sect. v, vol. i, pp. 10, 11, 16.)

FIG. 3. Trawl-roller which is attached to dory gunwale to haul trawls in shoal water. (Sect. v, vol. i, p. 10.)

Drawings by Capt. J. W. Collins.

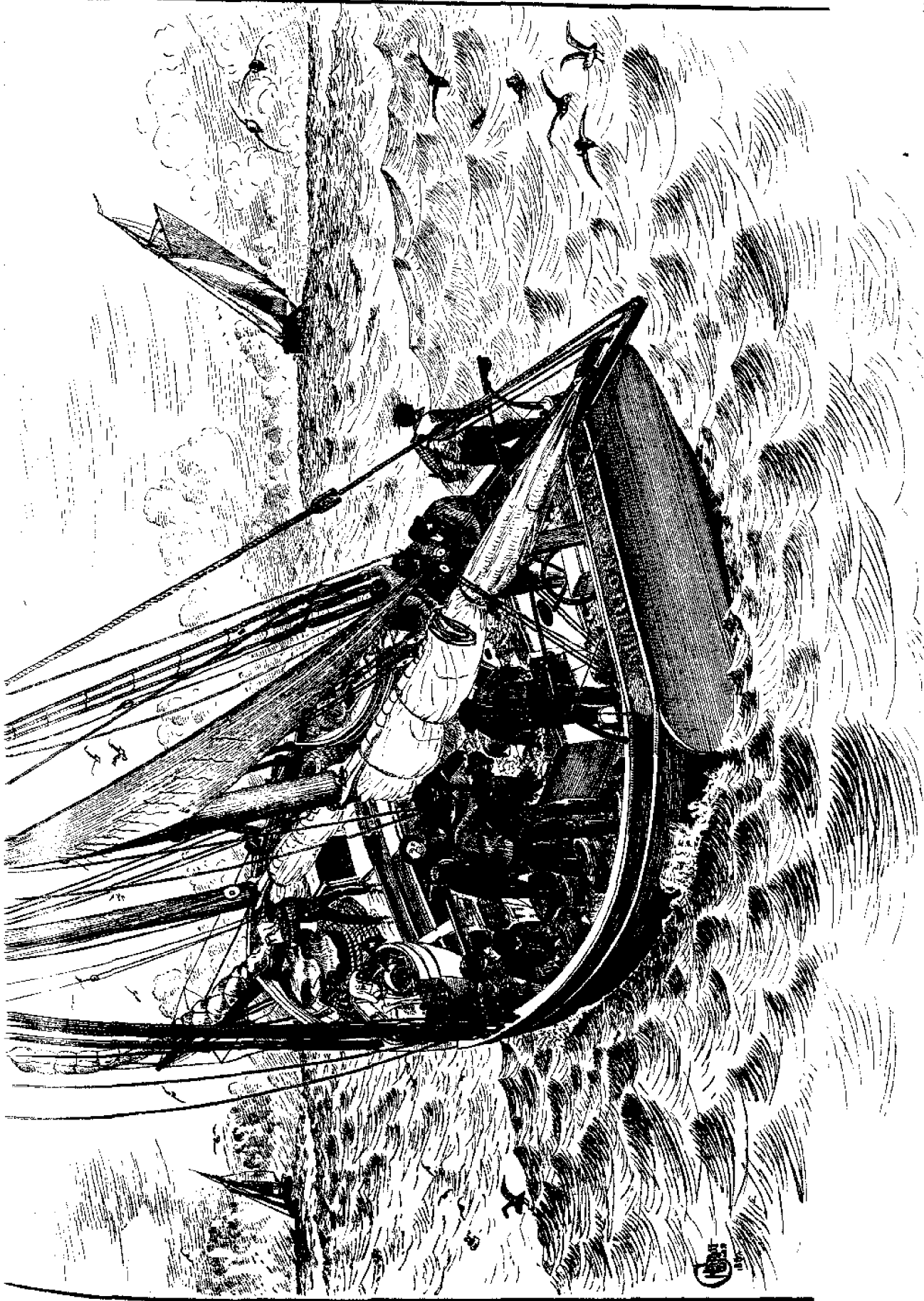

**THE FRESH HALIBUT FISHERY.**

Cutting bait and baiting trawls on halibut schooner at anchor on the fishing-grounds. (Sect. v, vol. i, p. 12.)

Drawing by H. W. Elliott and Capt. J. W. Collins.



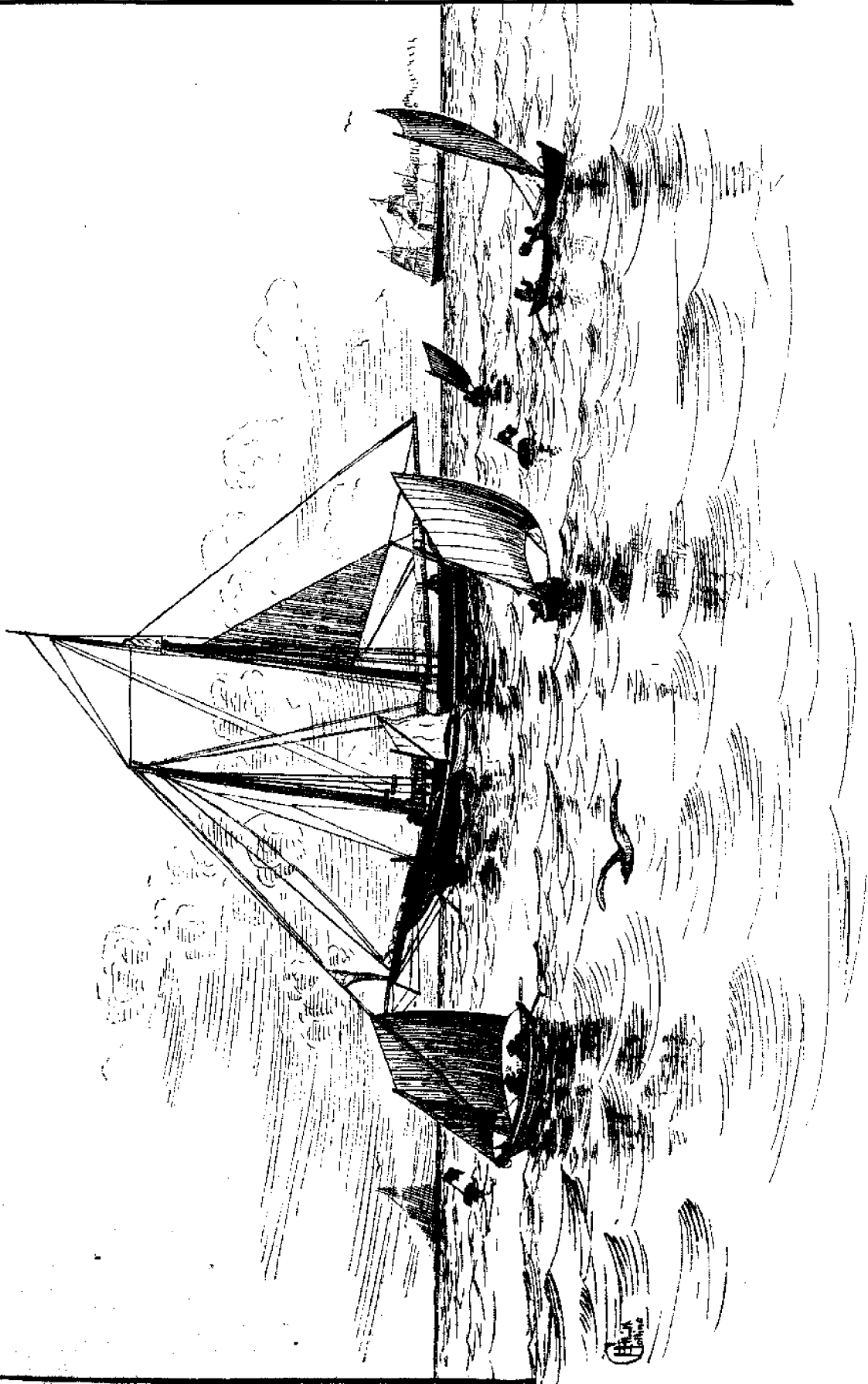

**THE FRESH HALIBUT FISHERY.**

Dories and crew on the way to haul the trawls: the schooner at anchor under riding sail. (Sect. V, vol. i, pp. 13-16.)

Drawing by H. W. Elliott and Capt. J. W. Collins.



**THE FRESH HALIBUT FISHERY.**

Halibut dory and crew hauling the trawl, gaffing and clubbing the halibut. (*Sect. v. vol. i, p. 16.*)

Drawing by H. W. Elliott and Capt. J. W. Collins.

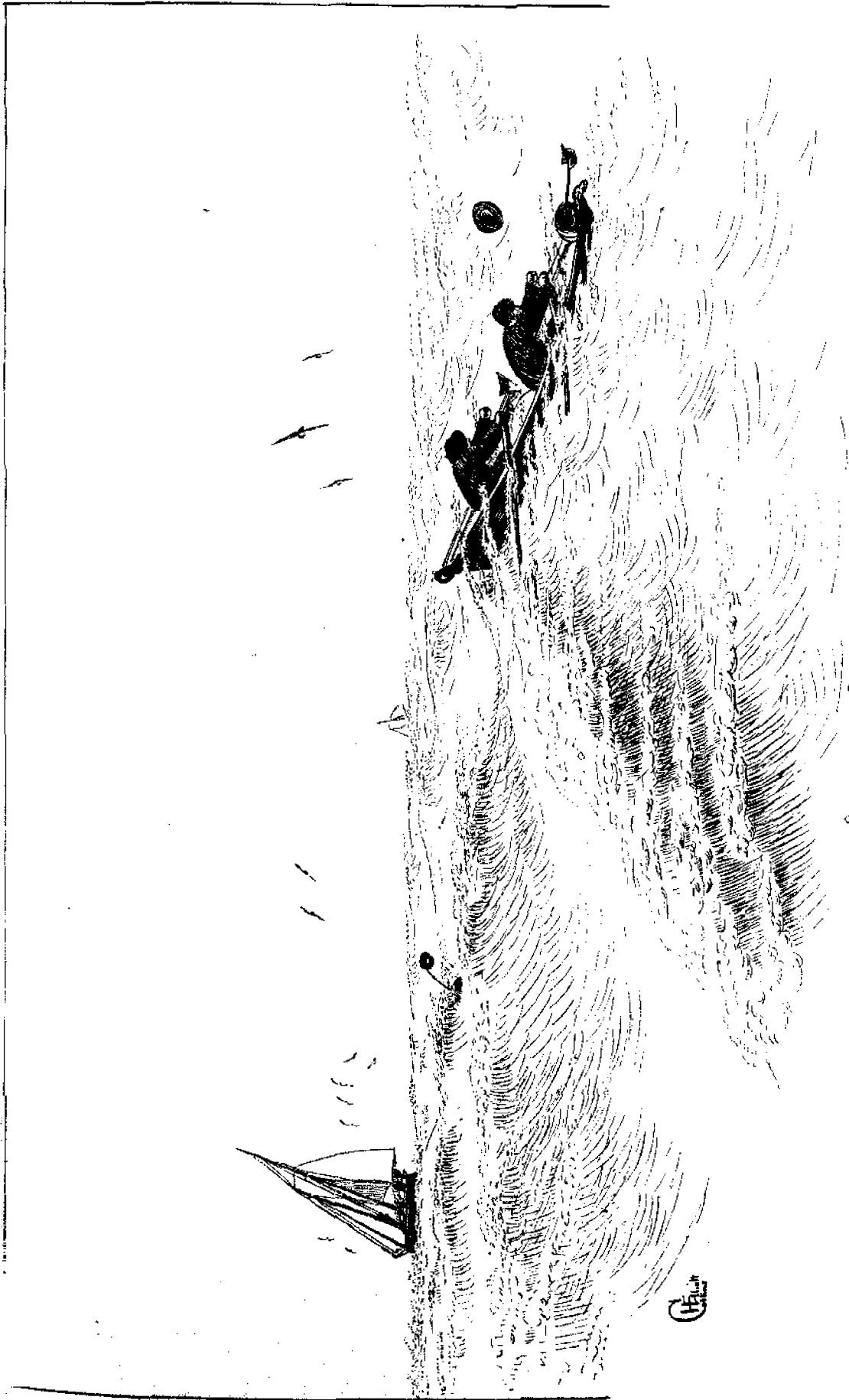

*A struggle for life.  
Caught to leeward in a dory.*

**THE FRESH HALIBUT FISHERY.**

Dory and crew caught to leeward in a storm while hauling the trawl. Trawl-buoy and line drifted astern of the vessel for their rescue. (Sect. v, vol. i, pp. 16, 30.)

Drawing by H. W. Elliott and Capt. J. W. Collins.

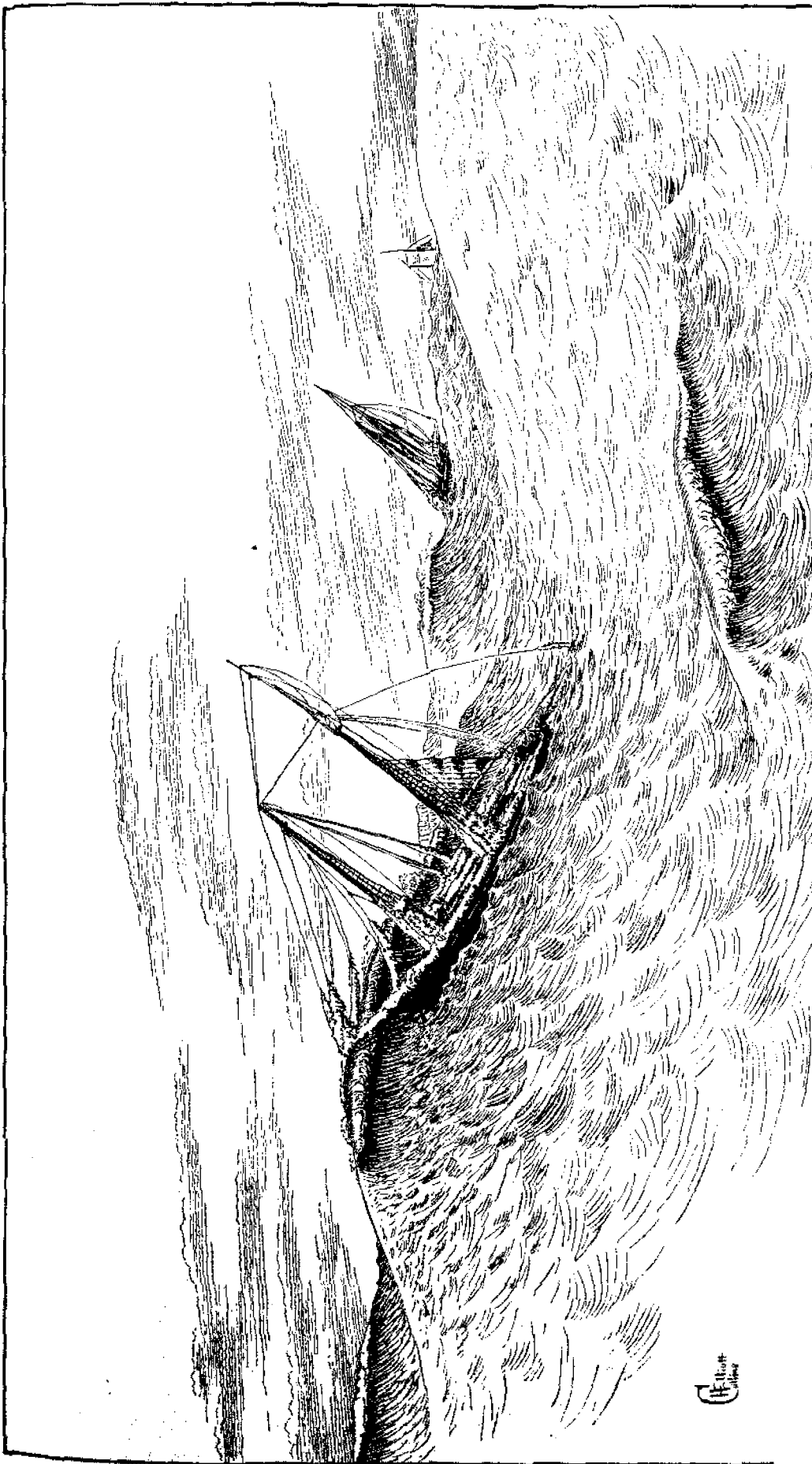

**THE FRESH HALIBUT FISHERY.**

Halibut schooner at anchor on the Grand Bank in winter, riding out a gale. (Sect. V, vol. 1, p. 84.)

Drawing by H. W. Elliott and Capt. J. W. Collins.

H. W. Elliott  
Capt. J. W. Collins

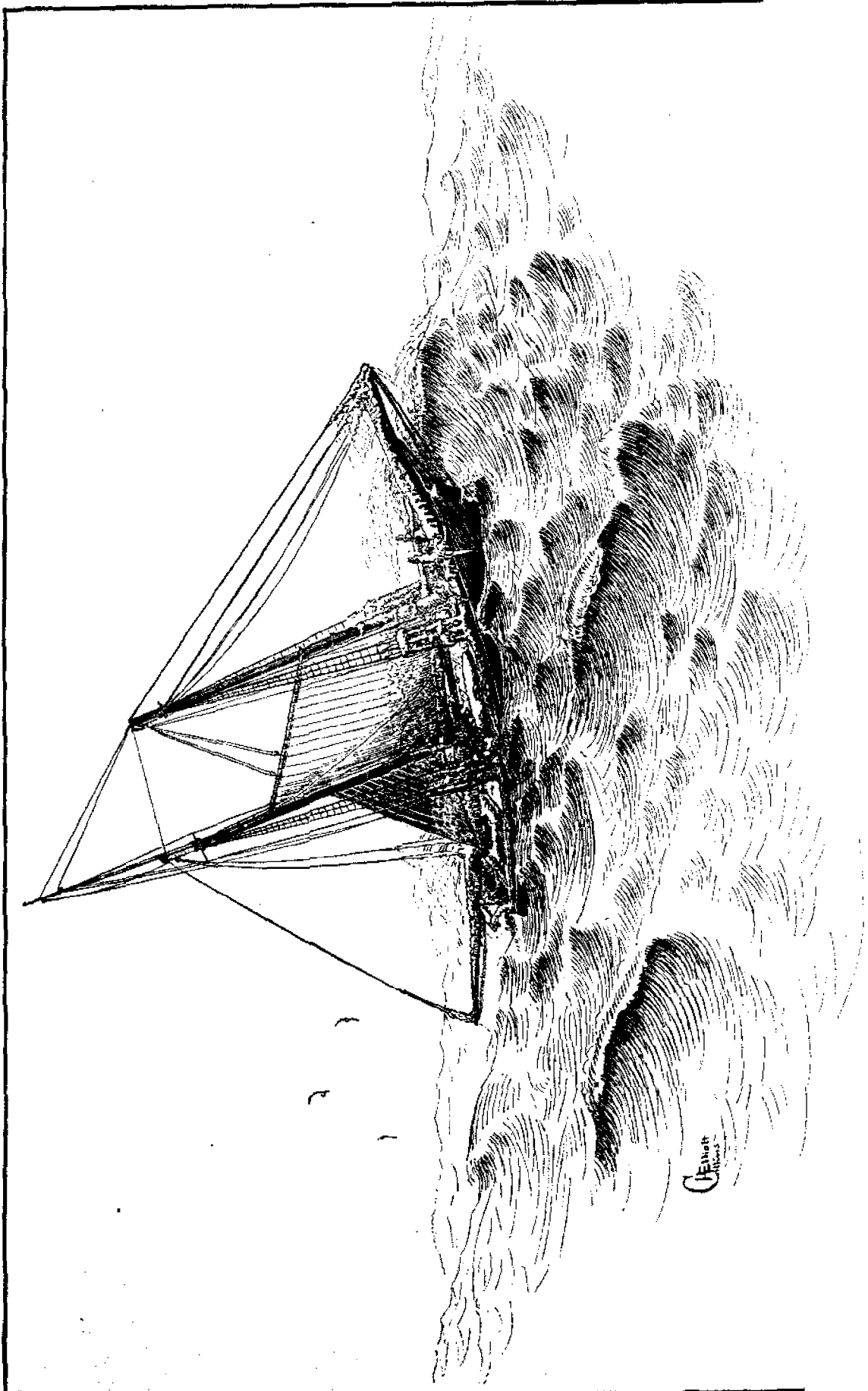

**THE FRESH HALIBUT FISHERY.**

Halibut schooner lying to in a gale on the Banks, under riding sail and double-reefed foresail. (Sect. V, Vol. I, p. 77.)

Drawing by H. W. Elliott and Capt. J. W. Collins.



**THE FRESH HALIBUT FISHERY.**

Halibut schooner tripped by a heavy sea. (Sect. v, vol. i, p. 70.)

Drawing by H. W. Elliott and Capt. J. W. Collins.

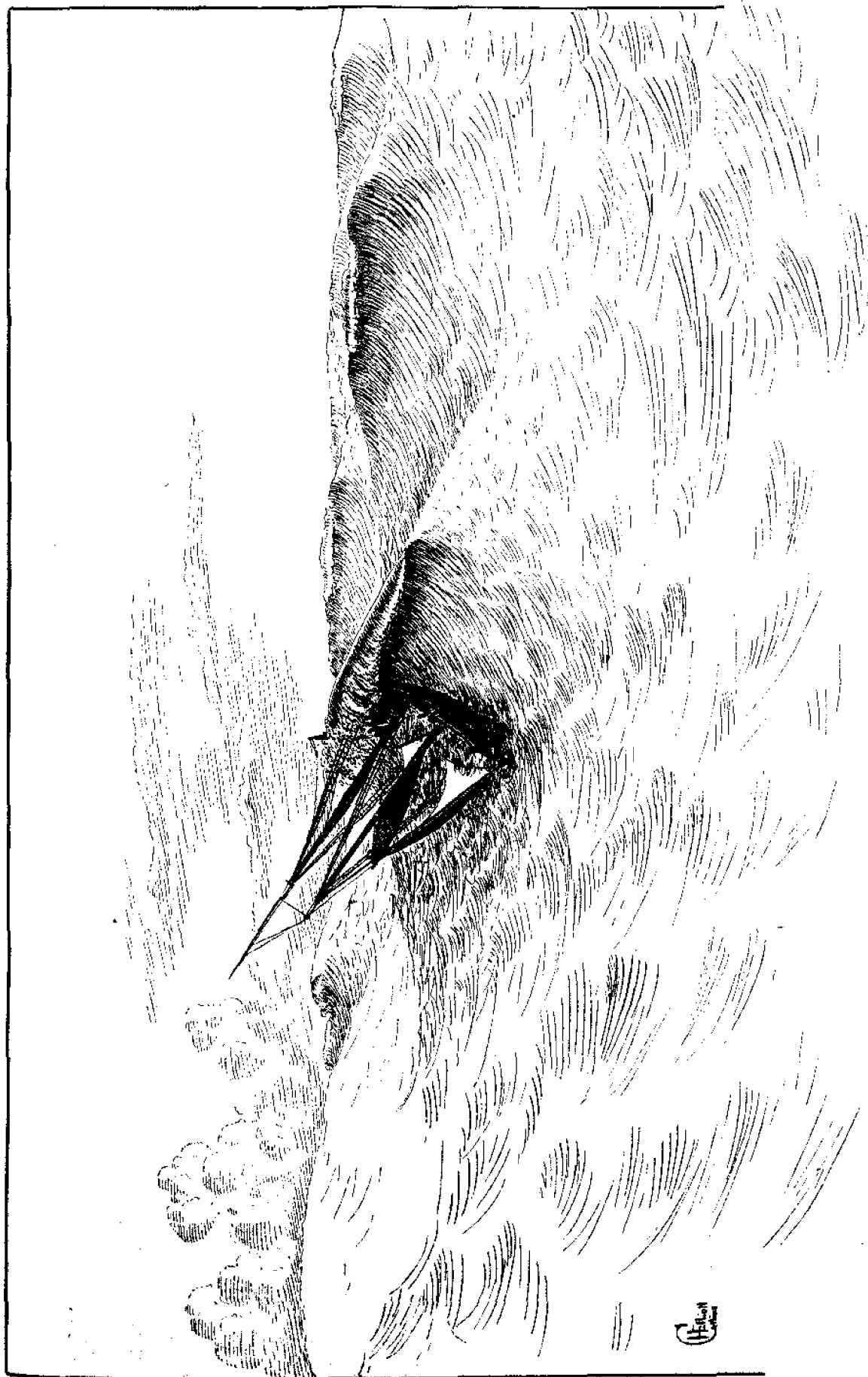

**H. W. Elliott**  
and  
**Capt. J. W. Collins**

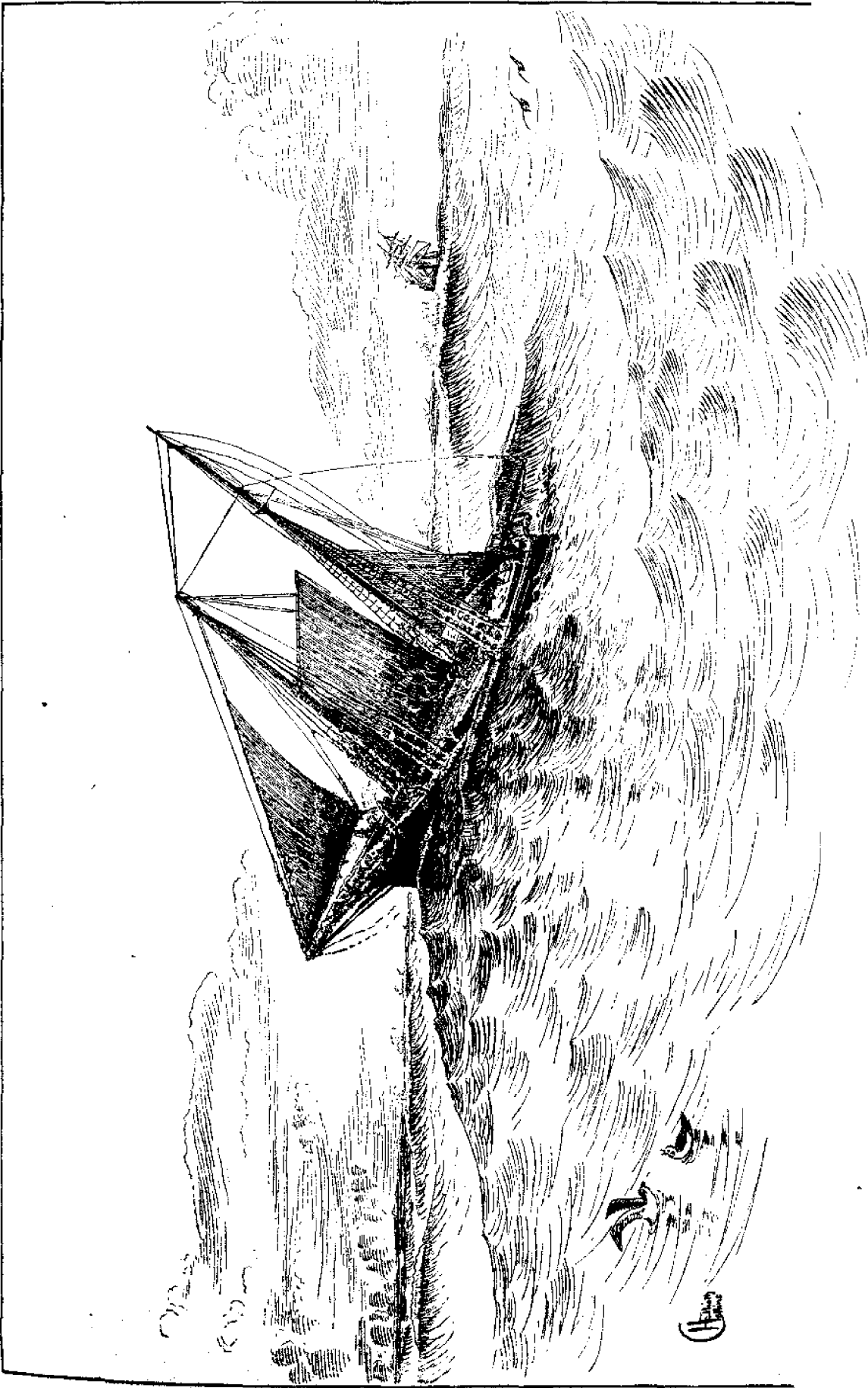

**THE FRESH HALIBUT FISHERY.**

Halibut schooner in winter; head-reaching under short sail. (Sect. V, vol. i, p. 20.)

Drawing by H. W. Elliott and Capt. J. W. Collins.

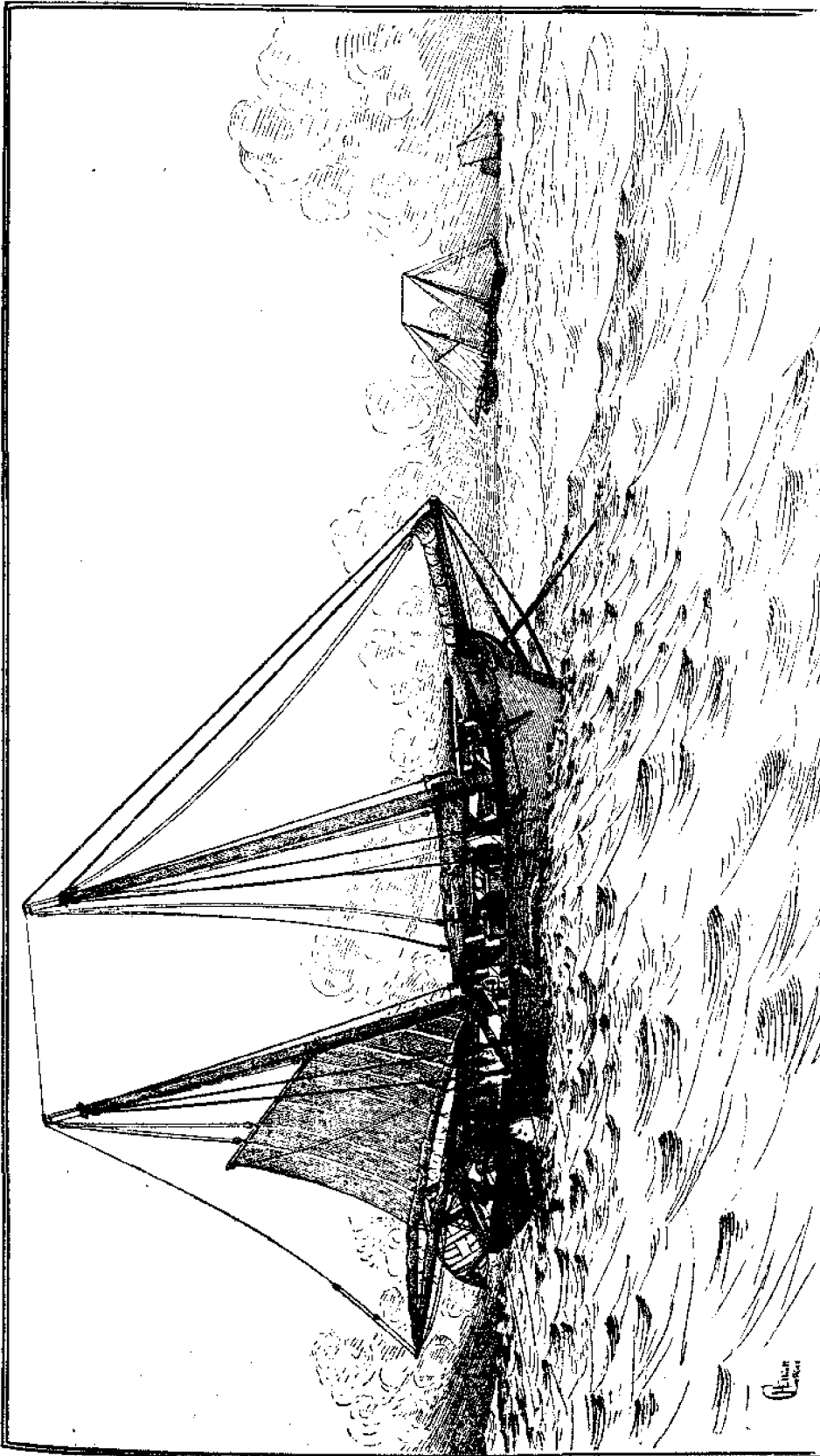

**THE FRESH HALIBUT FISHERY.**

Old style halibut schooner; hand-line fishing from deck; 1840 to 1850. (Sect. v, vol. i, pp. 20-43.)

Drawing by H. W. Elliott and Capt. J. W. Collins.

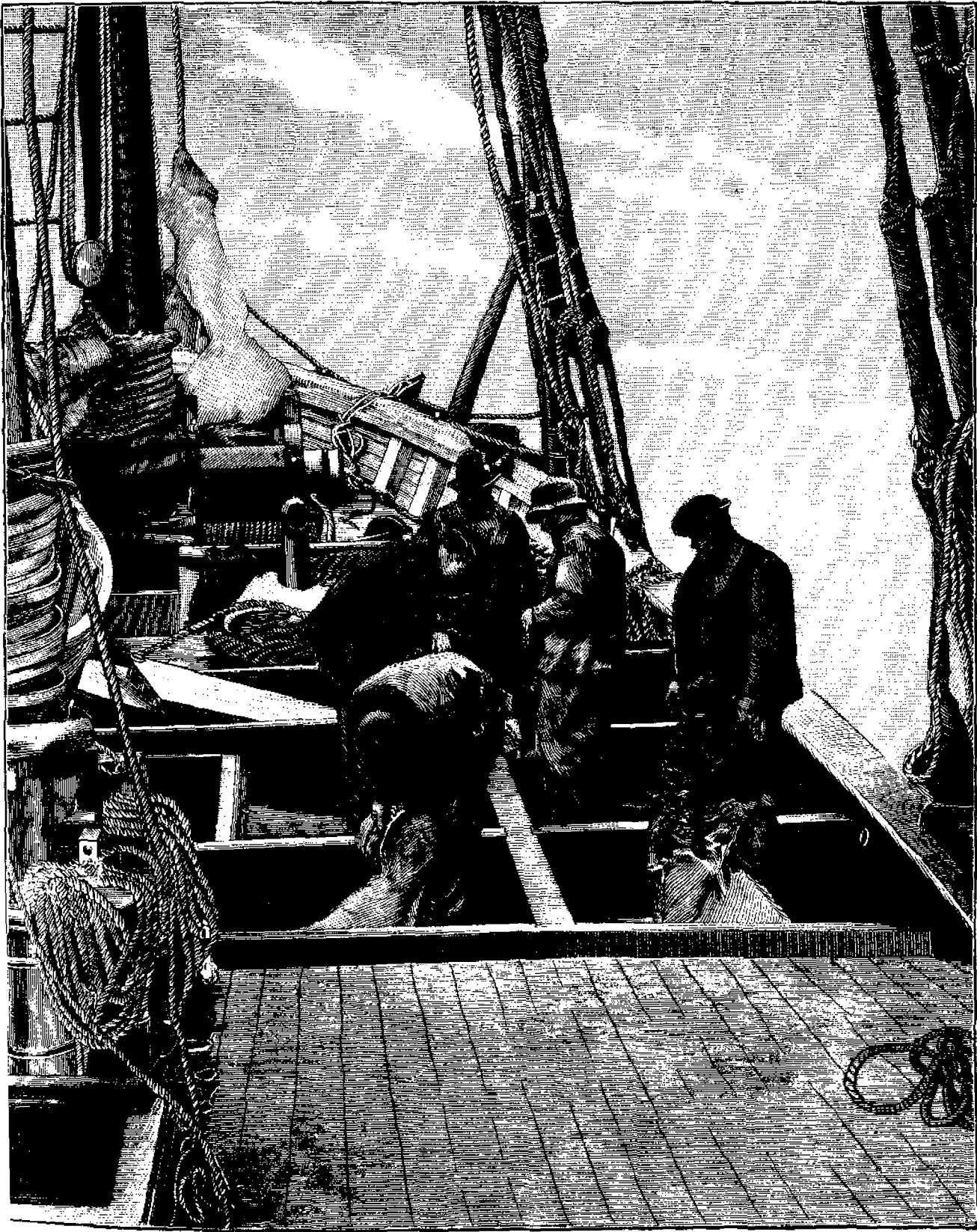

**THE FRESH HALIBUT FISHERY.**

Dressing halibut on deck of schooner for icing in the hold. (Sect. v, vol. 1, p. 19.)

From a photograph by T. W. Smillie, 1882.

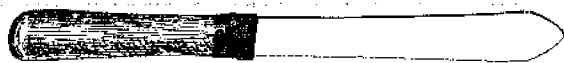

Fig. 1.

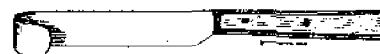

Fig. 2.

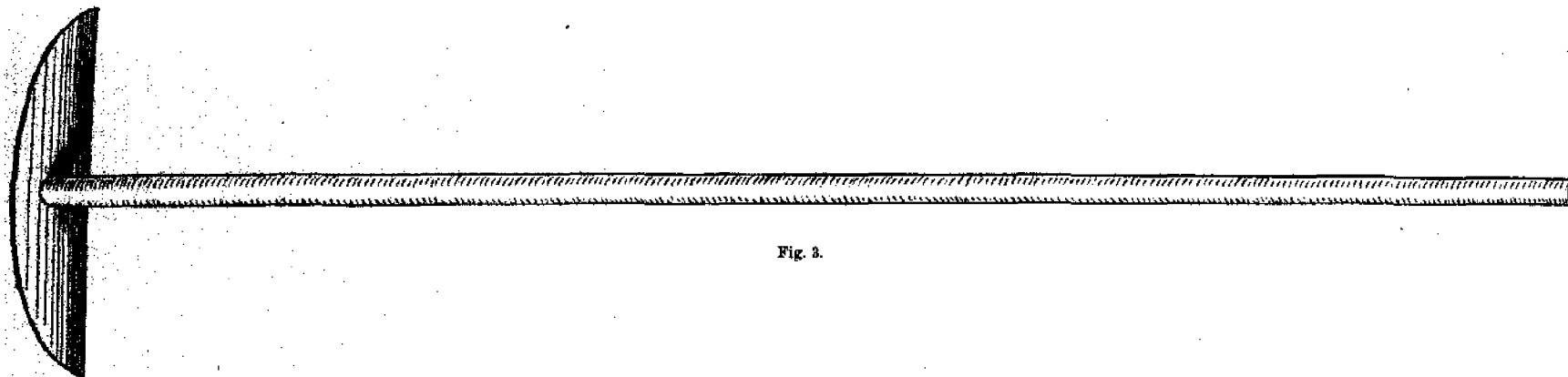

Fig. 3.

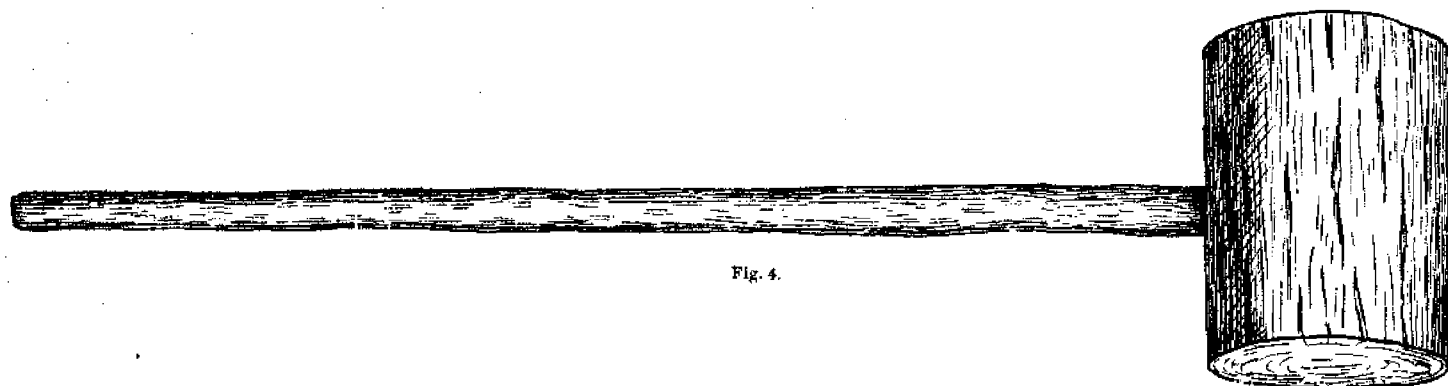

Fig. 4.

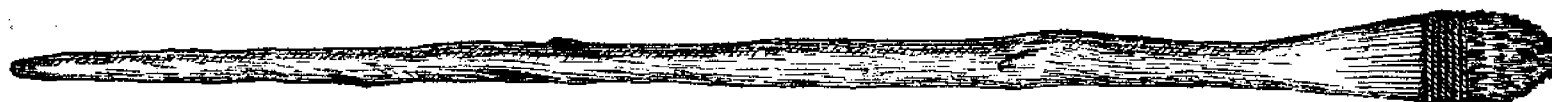
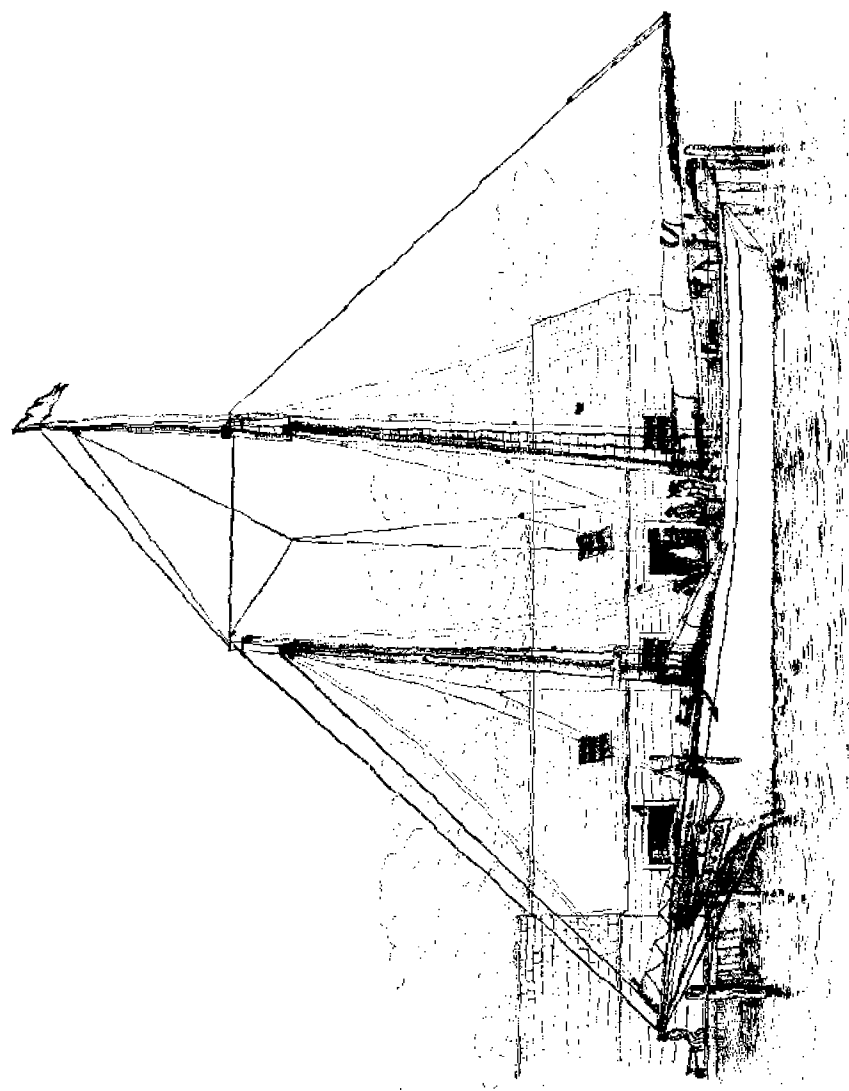

Fig. 5.

### THE FRESH HALIBUT FISHERY.

- FIG. 1. Halibut cutting knife. (Sect. v, vol. i, p. 19.)  
FIG. 2. Scraping-knife to remove muscle and flesh from backbone after cutting. (Sect. v, vol. i, p. 19.)  
FIG. 3. Squilgee for pushing broken ice in pens. (Sect. v, vol. i, p. 19.)  
FIG. 4. Oak mallet for breaking ice. (Sect. v, vol. i, p. 19.)  
FIG. 5. Oak broom for scrubbing halibut. (Sect. v, vol. i, p. 19.)

Drawings by Capt. J. W. Collins.



**THE FRESH HALIBUT FISHERY.**

General view of schooner discharging fare of fresh halibut at Gloucester, Mass. (Sect. V, vol. I, p. 21.)

Drawing by Capt. J. W. Collins.

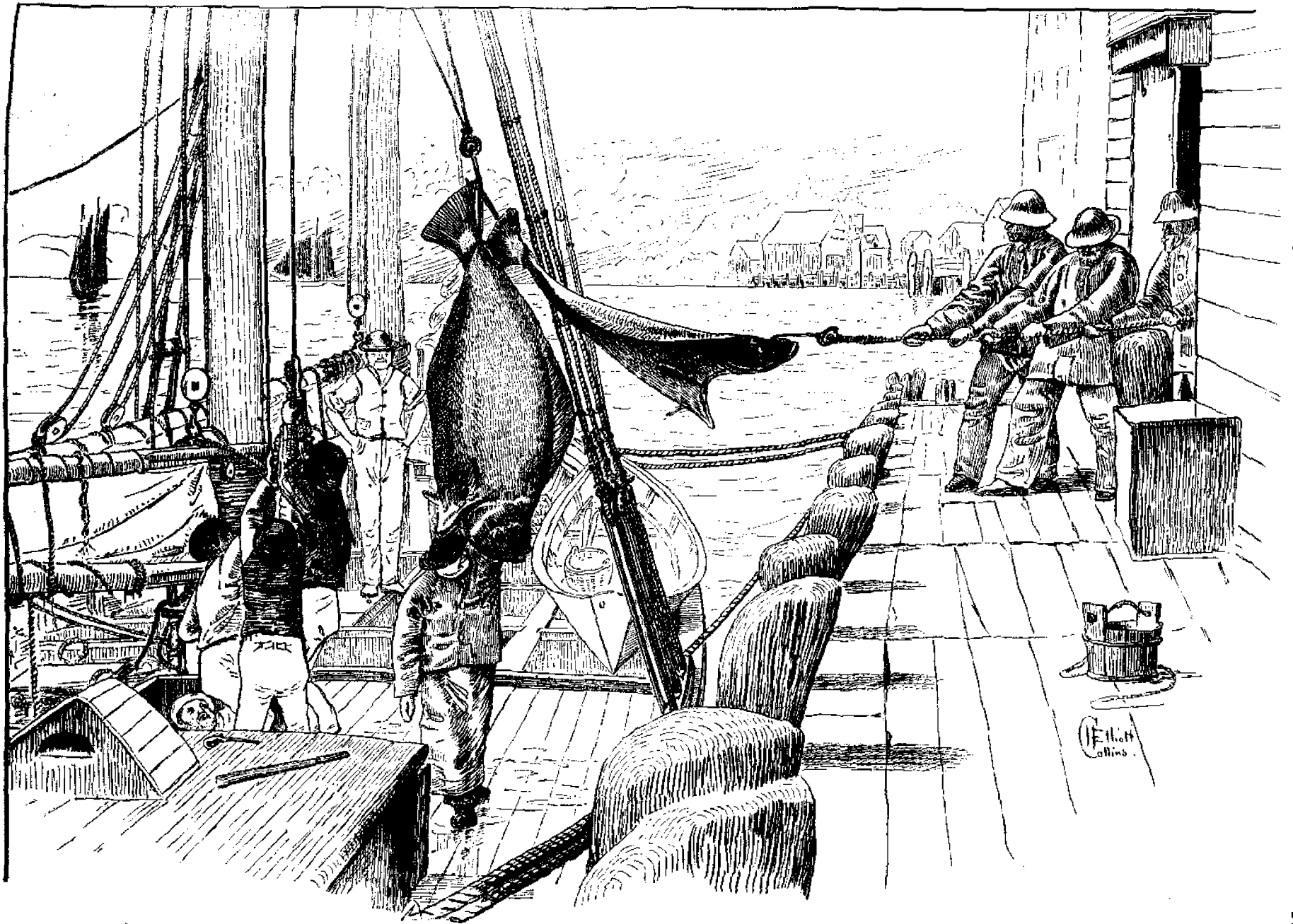

**THE FRESH HALIBUT FISHERY.**

Hoisting halibut from hold of schooner, at Gloucester, Mass. (Sect. v, vol. i, p. 22.)

Drawing by H. W. Elliott and Capt. J. W. Collins.

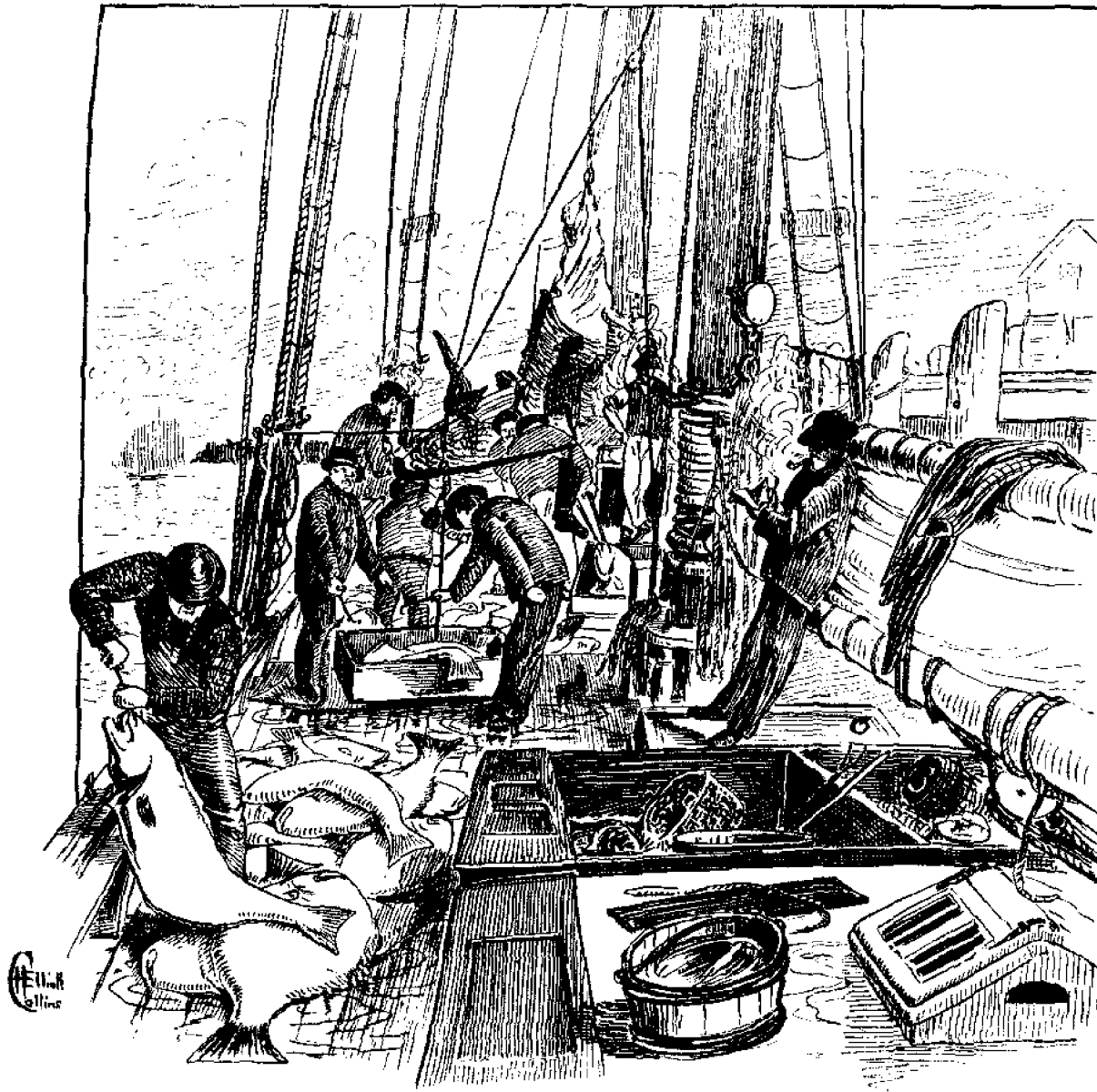

**THE FRESH HALIBUT FISHERY.**

Weighing and selling halibut on deck of George's Bank hand-line cod schooner. These vessels often catch halibut while fishing for cod. (Sect. v, vol. i. p. 22.)

Drawing by H. W. Elliott and Capt. J. W. Collins. 1882.



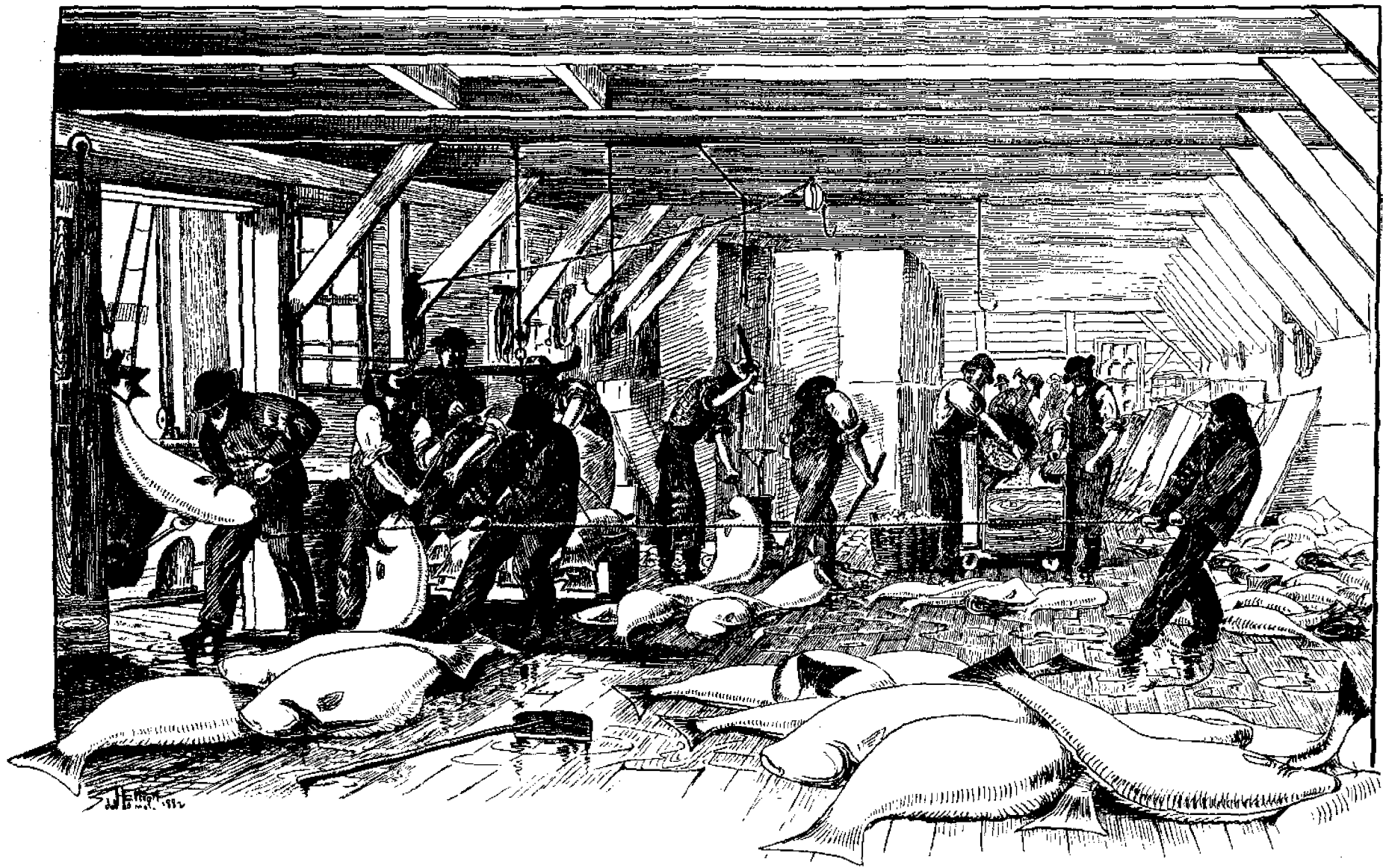

**THE FRESH HALIBUT FISHERY.**

Handling fresh halibut at Gloucester, Mass. Weighing, unheading, and packing in ice for shipment by rail. (Seef. v, vol. i, p. 22.)

Drawn by H. W. Elliott. 1882.

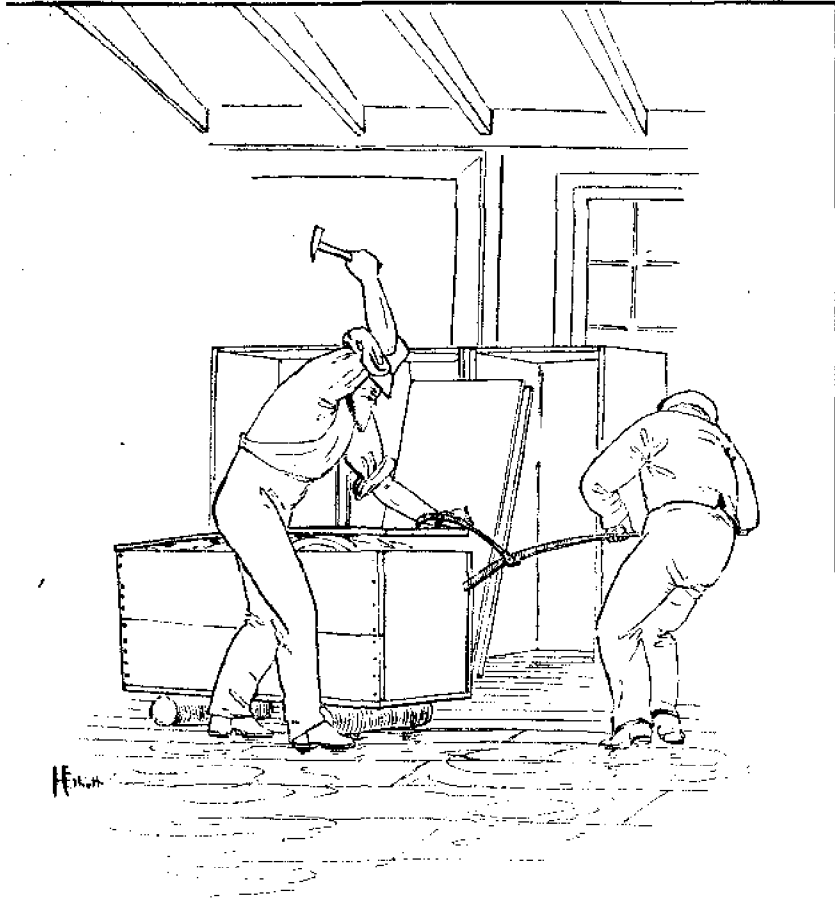

Nailing covers on the boxes; the use of the devil's claw.



Preparing ice with pick and grinding machine.

**THE FRESH HALIBUT FISHERY.**

Packing fresh halibut at Gloucester, Mass. (Sect. v, vol. i, p. 22.)

Drawings by H. W. Elliott.

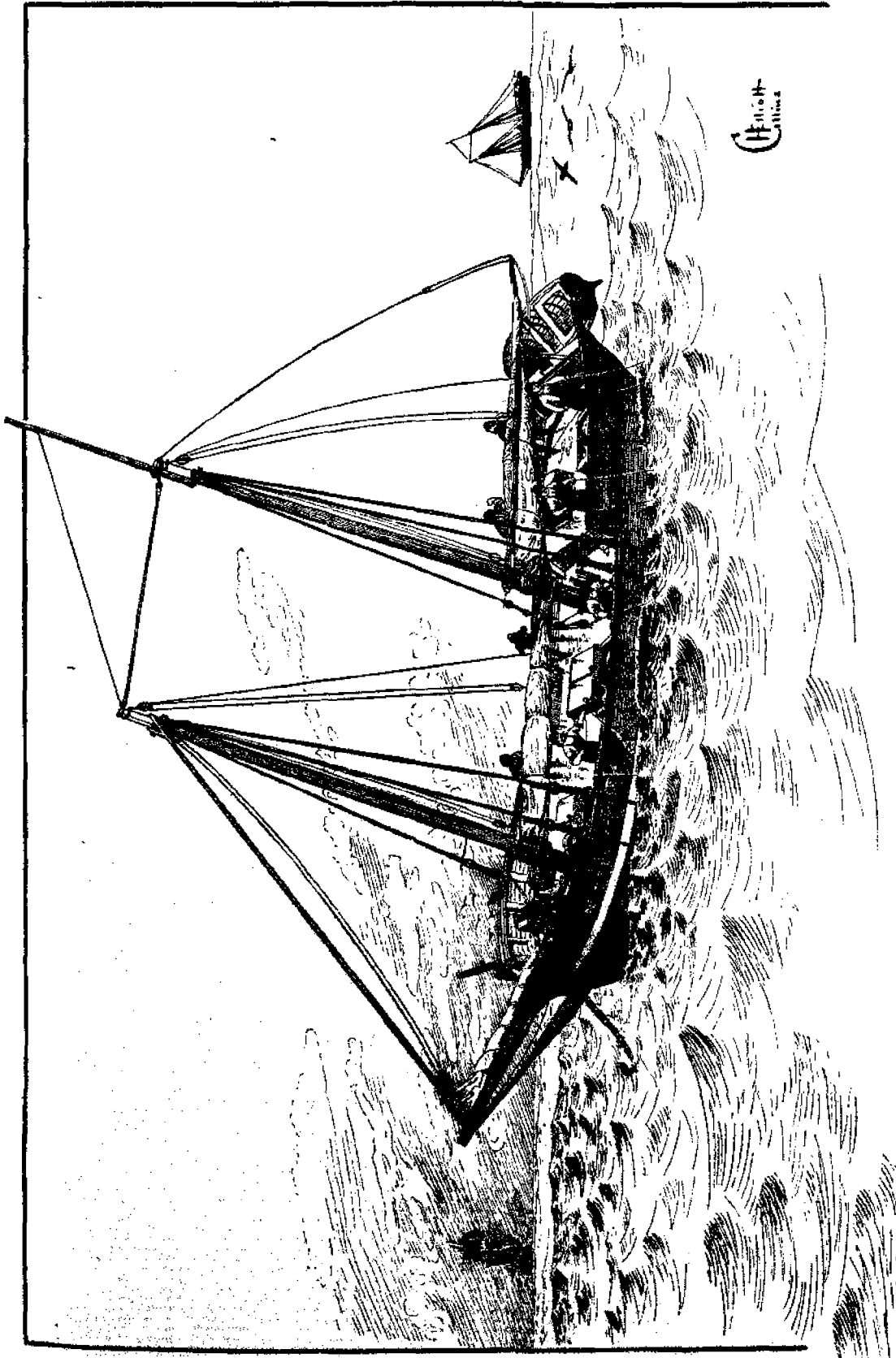

**THE BANK HAND-LINE COD FISHERY.**

Old style Grand Bank cod schooner; crew at rail hand-line fishing. (Sect. v, vol. i, pp. 125, 126.)

Drawing by H. W. Elliott and Capt. J. W. Collins.

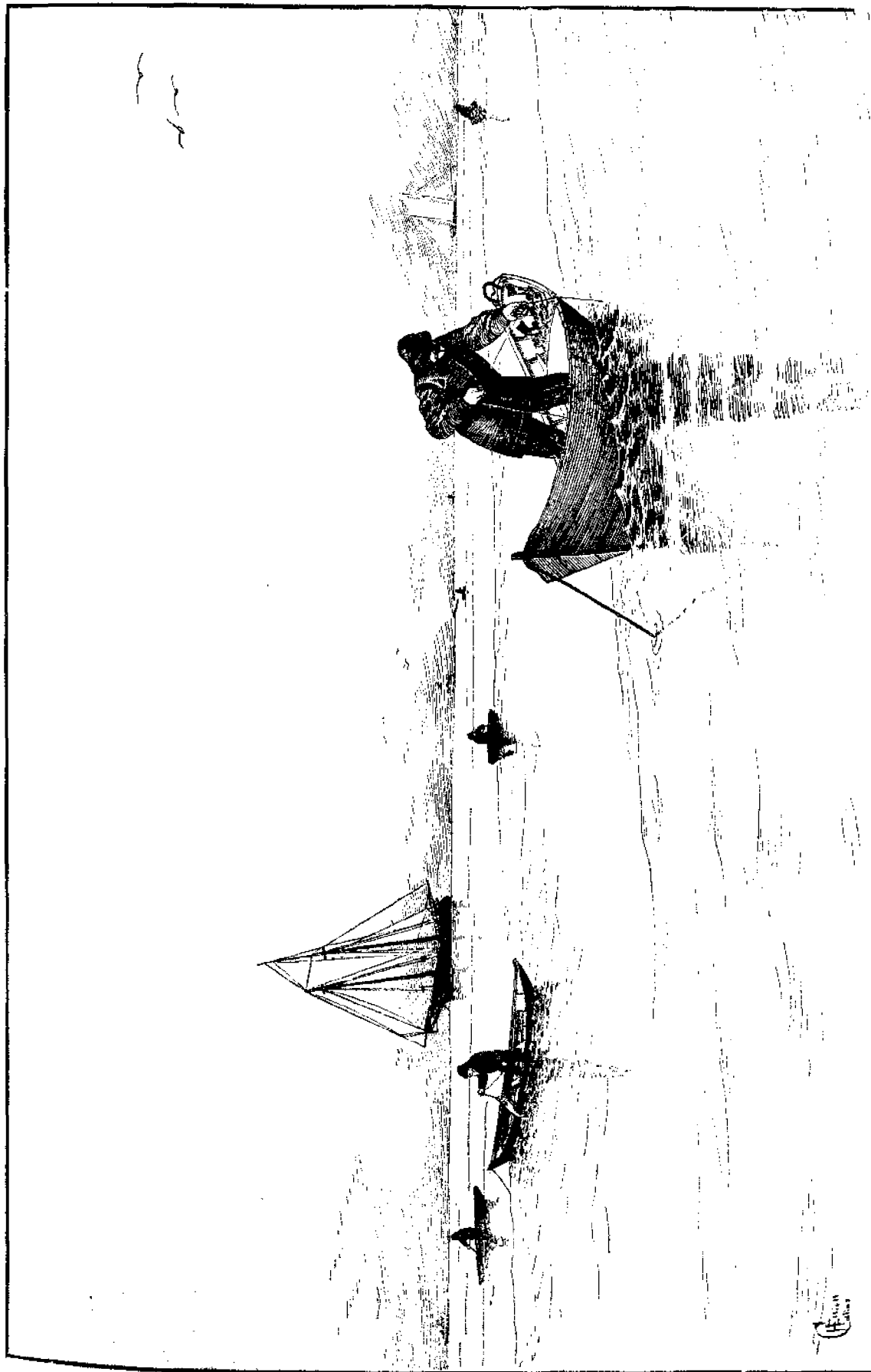

**THE BANK HAND-LINE COD FISHERY.**

Hand-line story cod fishing on the Grand Bank. (Sect. v. vol. i, p. 126.)

Drawing by H. W. Elliott and Capt. J. W. Collins.

H. W. Elliott  
Capt. J. W. Collins

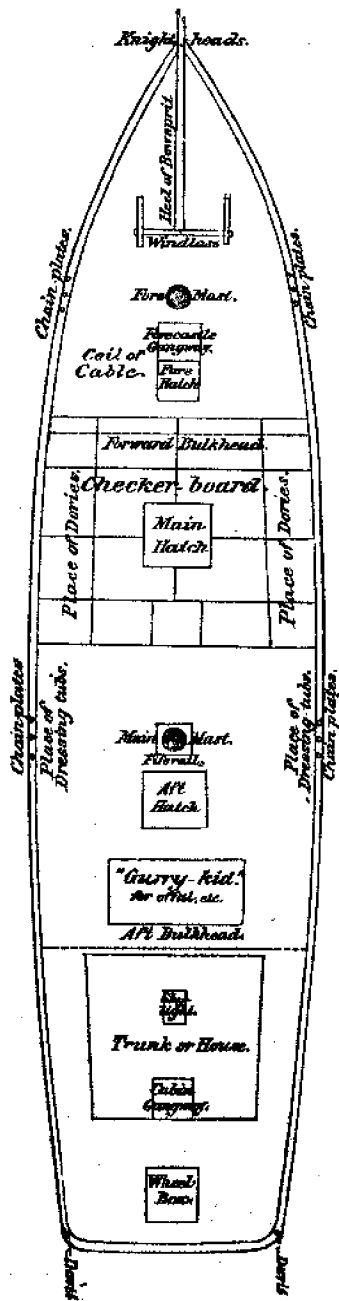

*Sketch of the Deck of COD SCHOONER Centennial, Capt. B.A. Williams, Gloucester, Mass.*

*Scale 1 inch=15 feet.*

*Tonnage, 115, 96 tons.  
Bowsprit 21 ft. beyond the Knight-heads.  
Jib-boom, 15 ft.  
Fore Mast, 76 ft.: no top mast.  
Fore boom, 32 ft.  
Main Mast, 73 ft. Main top-mast, 10-18 ft.  
Main boom, 68 ft.  
6 dories.*

**THE BANK TRAWL-LINE COD FISHERY.**

Deck plan of cod schooner Centennial, of Gloucester, Mass. (Sect. v, vol. i, p. 149.)

Drawing by Capt. J. W. Collins.

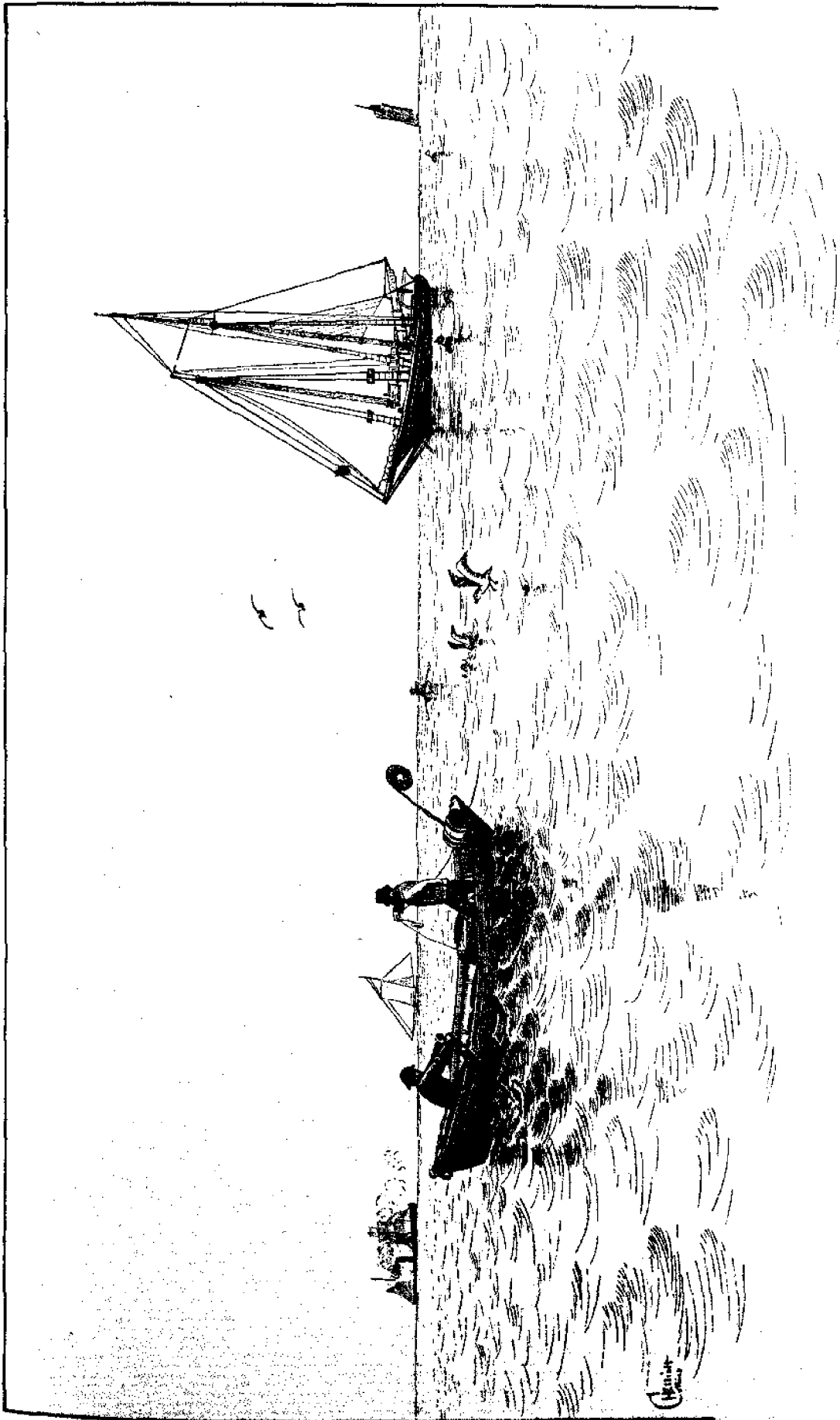

**THE BANK TRAWL-LINE COD FISHERY.**

Dory and crew setting cod trawl-lines on the Bank. (Sect. v. vol. i, pp. 152, 176.)

Drawing by H. W. Elliott and Capt. J. W. Collins.

Chiswick  
Press

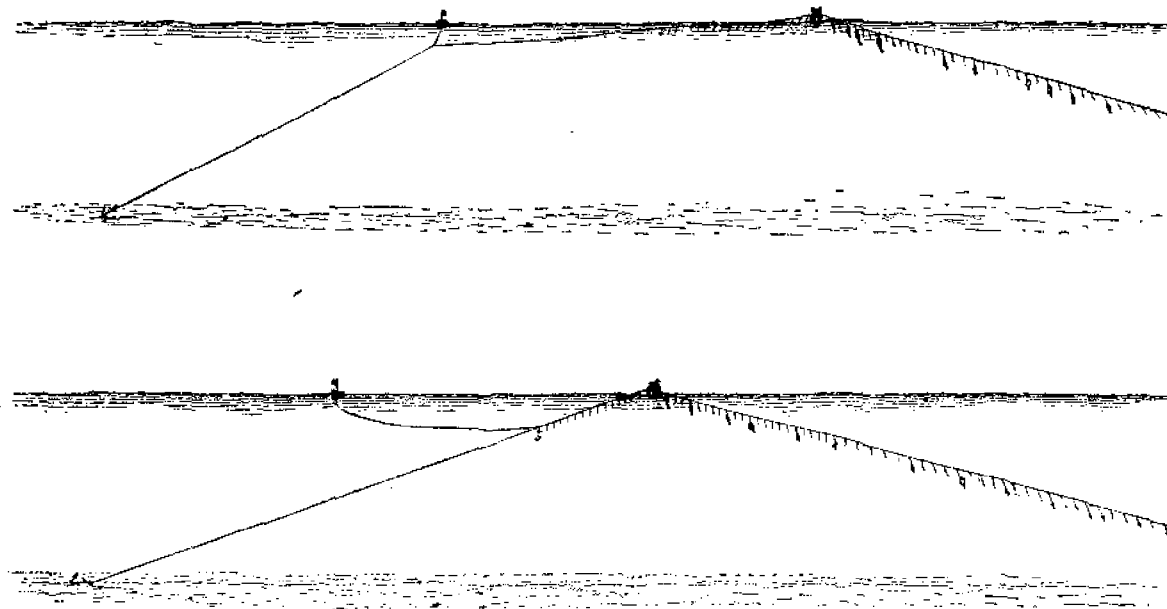

**THE BANK TRAWL-LINE COD FISHERY.**

Underrunning cod trawls; two methods of setting trawl for underrunning. (Sect. v, vol. i, pp. 154, 177.)

1, set with bridle. 2, set straight.

Drawings by Capt. J. W. Collins.



**THE BANK TRAWL-LINE COD FISHERY.**

Newfoundland fishermen catching squid for sale as cod bait to United States vessels. (Sect. v, vol. i, pp. 152, 154.)

Drawing by H. W. Elliott and Capt. J. W. Collins.



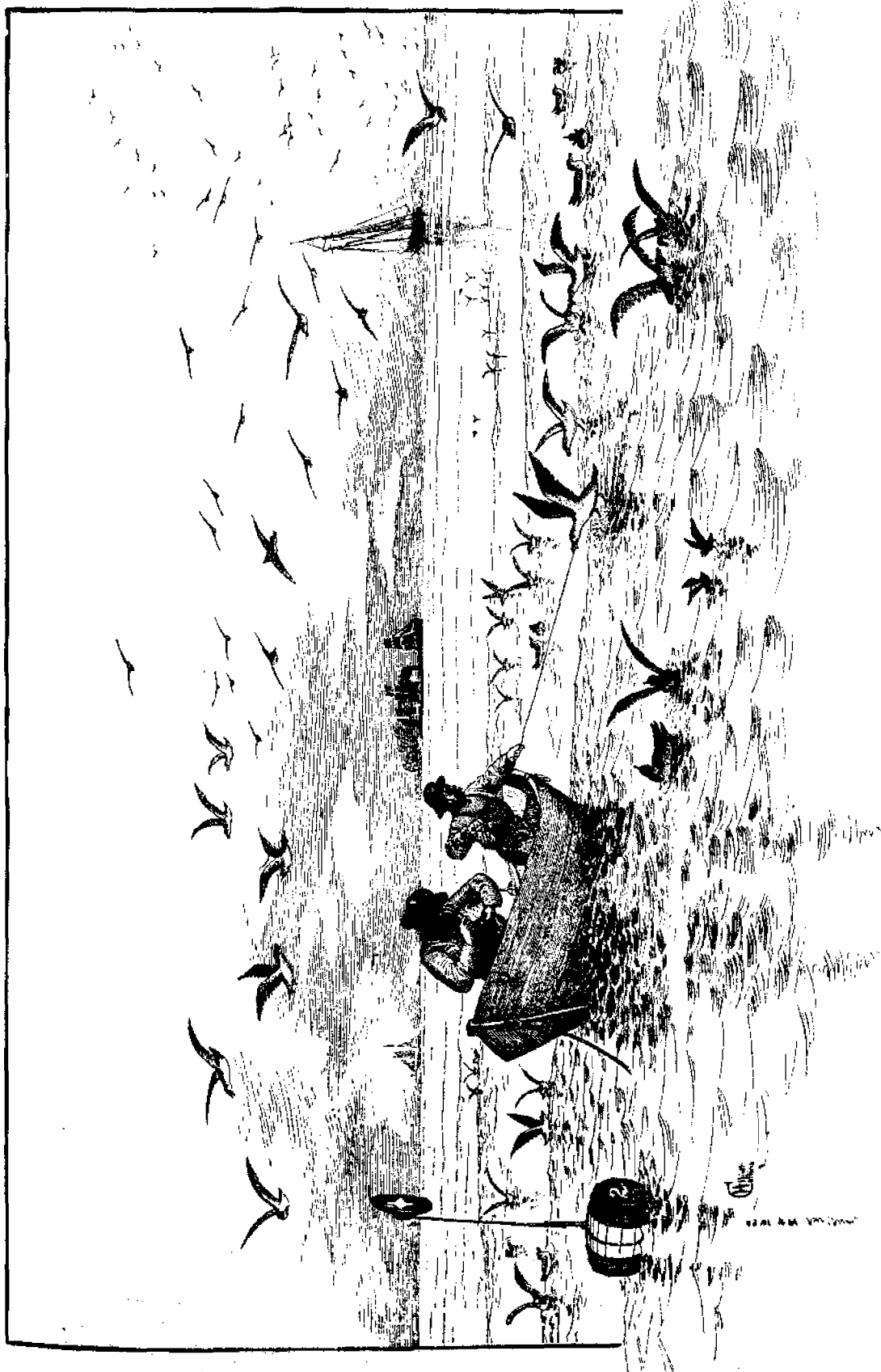

**THE BANK TRAWL-LINE COD FISHERY.**

Dory crew of cod fishermen catching birds for bait. (Seef. v, vol. 3, p. 152.)

Drawing by H. W. Elliott and Capt. J. W. Collins



THE GEORGE'S BANK COD FISHERY.

Gloucester schooner at anchor on the Bank: hand line fishing; rigged without topmasts, for rough weather. (Sect. v, vol. i, pp. 192, 193.)

From painting by Paul E. Collins.

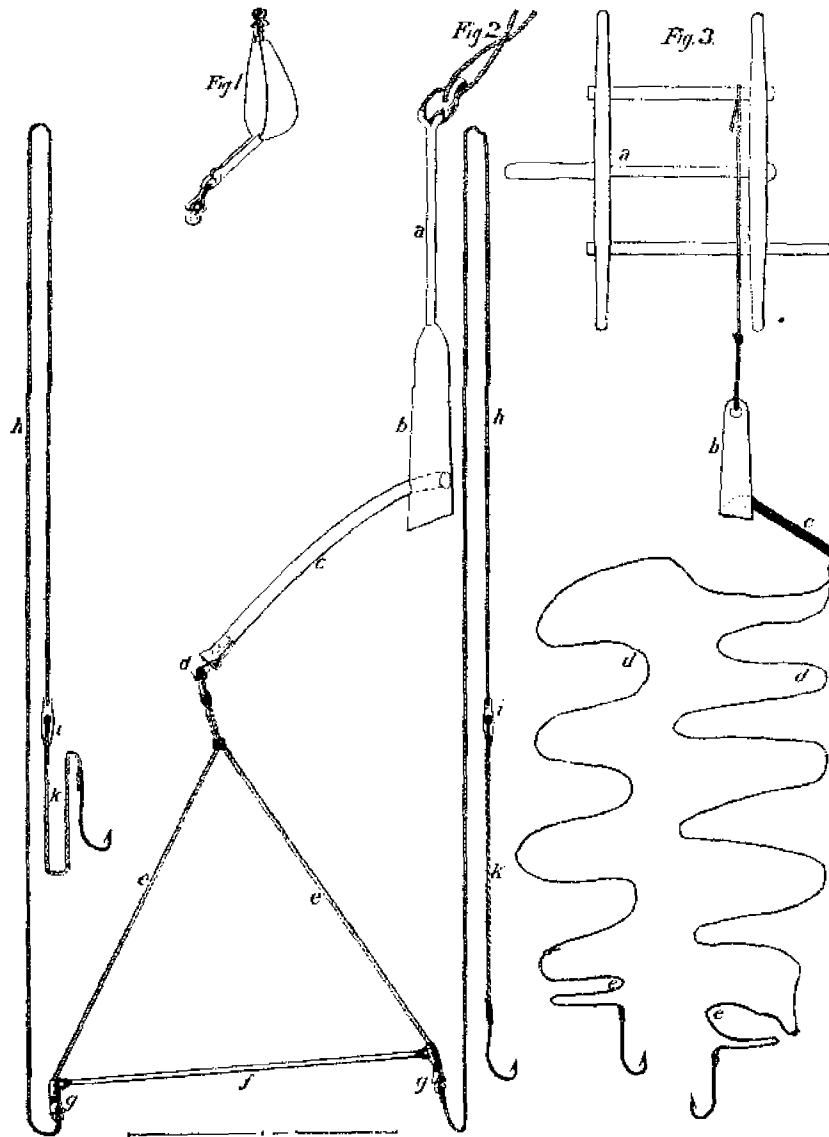

**THE HAND-LINE COD FISHERY.**

Cod hand-line gear. (Sect. v, vol. i, p. 192.)

FIG. 1. Lead sinker of the "Sow-bug" type, with brass horse and swivels.

FIG. 2. George's hand-line gear: a, tail; b, lead; c, wooden horse; d, swivel; e, bridle; f, iron spreader or sling-ding; g, snood swivel; h, snood; i, hook slot-swivel; k, ganging.

FIG. 3. Hand-line gear for shoal water as formerly rigged, without spreader or swivels: a, reel; b, lead; c, rope horse; d, snood; e, ganging.

Drawings by Capt. J. W. Collins.

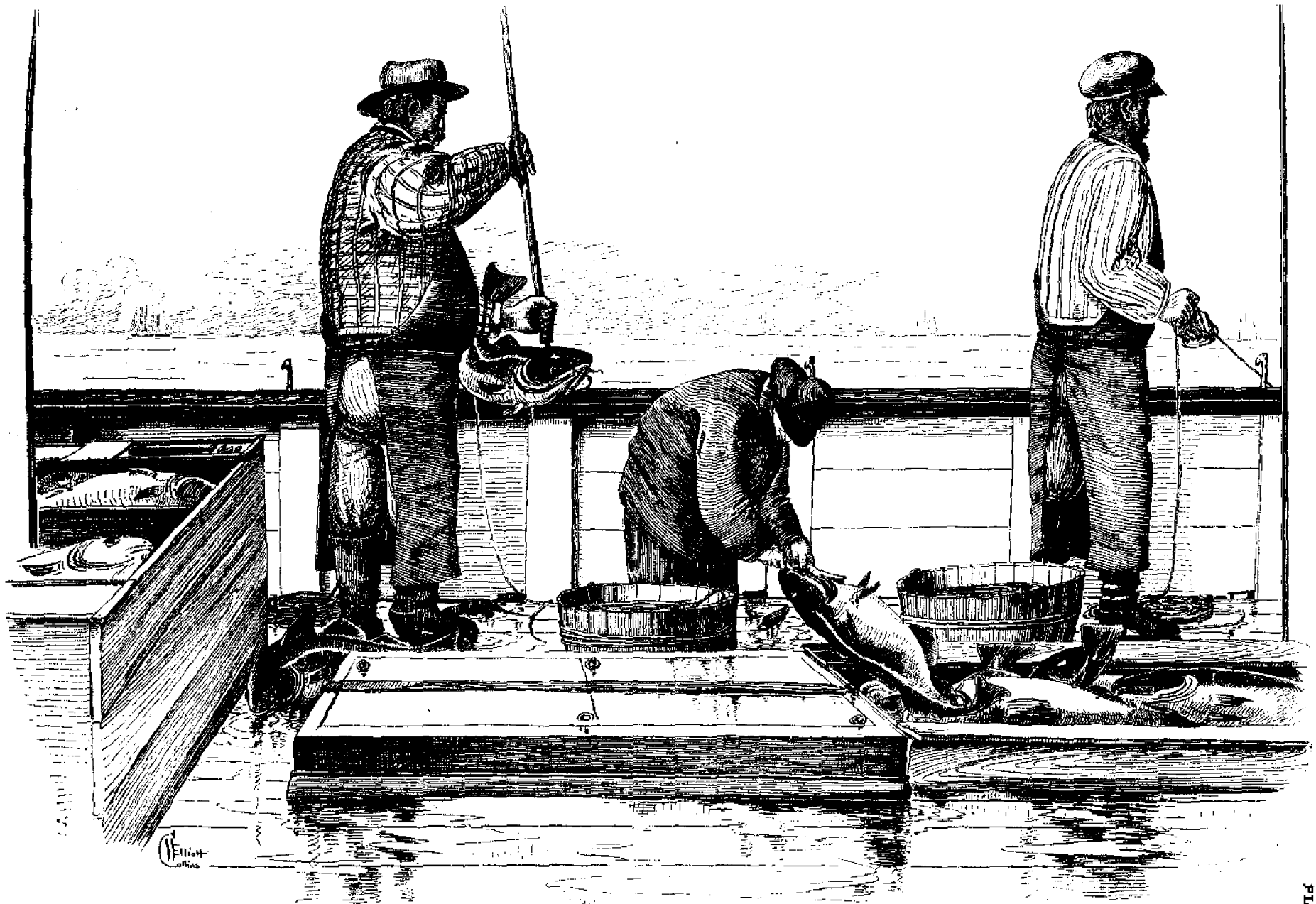

**THE GEORGE'S BANK COD FISHERY.**

George's crew hand-line fishing; gaffing fish over the rail; cutting out tongues. (Sect. v. vol. i. p. 194.)

Drawing by H. W. Elliott and Capt. J. W. Collins.



**THE GEORGE'S BANK COD FISHERY.**

Dressing cod on deck of fishing schooner. (Sect. v, vol. i, pp. 156, 180, 195.)

Drawing by H. W. Elliott and Capt. J. W. Callus.

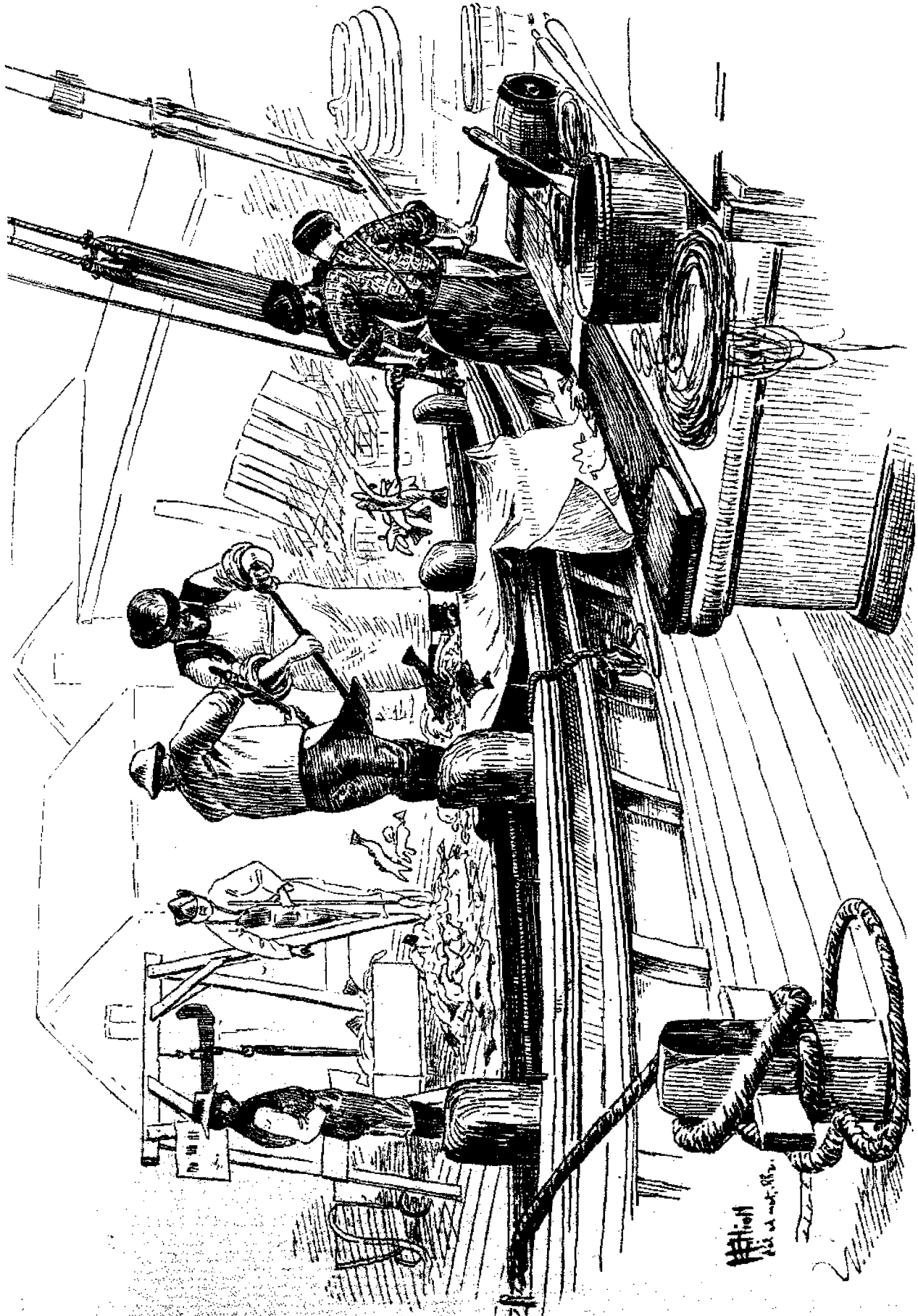

**THE GEORGE'S BANK COD FISHERY.**

Discharging fare of George's codfish at Gloucester, Mass. (Sect. v, vol. i, p. 195.)

Drawing by H. W. Elliott.

H. W. Elliott  
1872

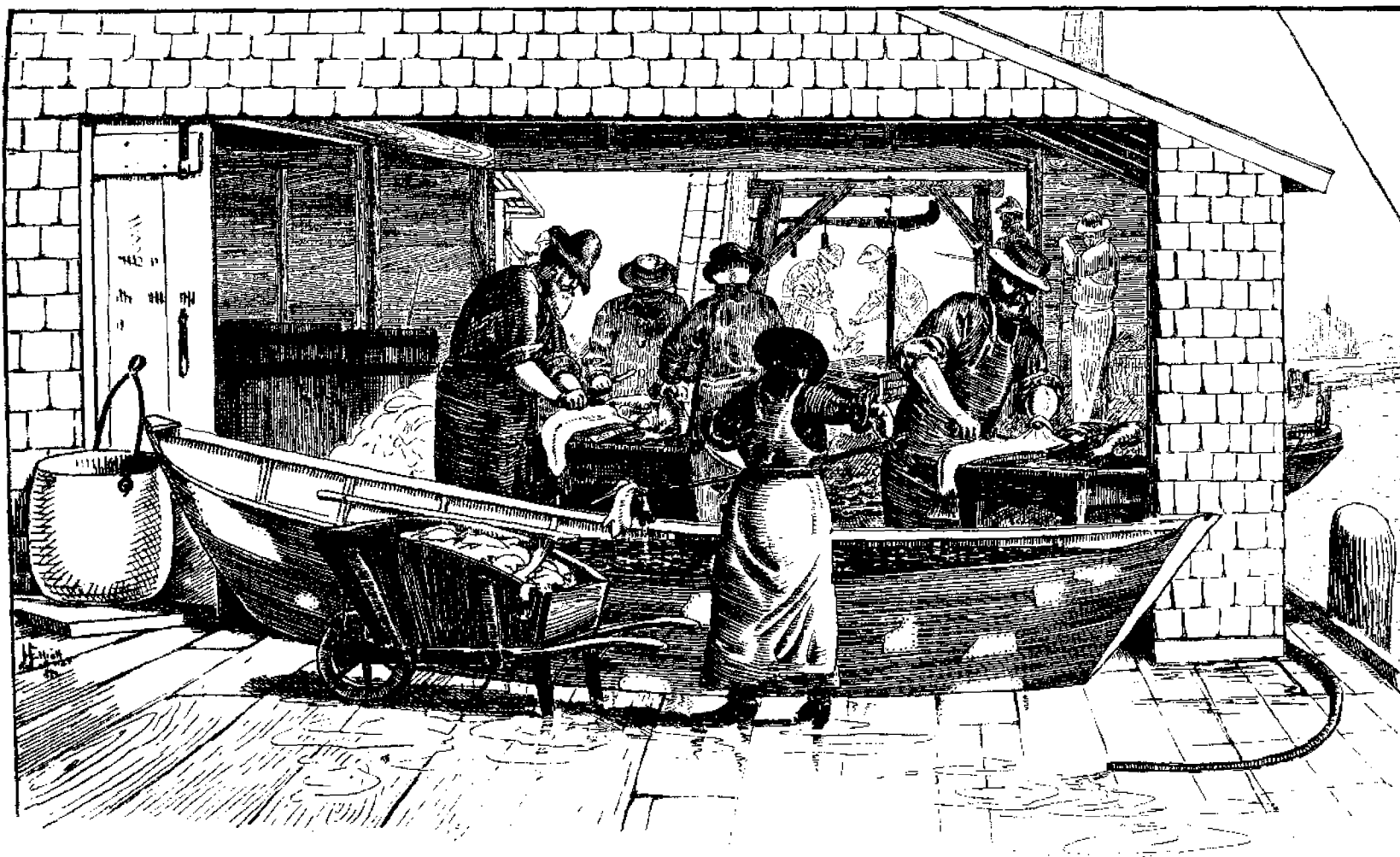

**THE GEORGE'S BANK COD FISHERY.**

Splitting and washing George's Bank cod at Wonsen's wharf, Gloucester, Mass. (Sect. v, vol. i, p. 195.)

Drawing by H. W. Elliott.

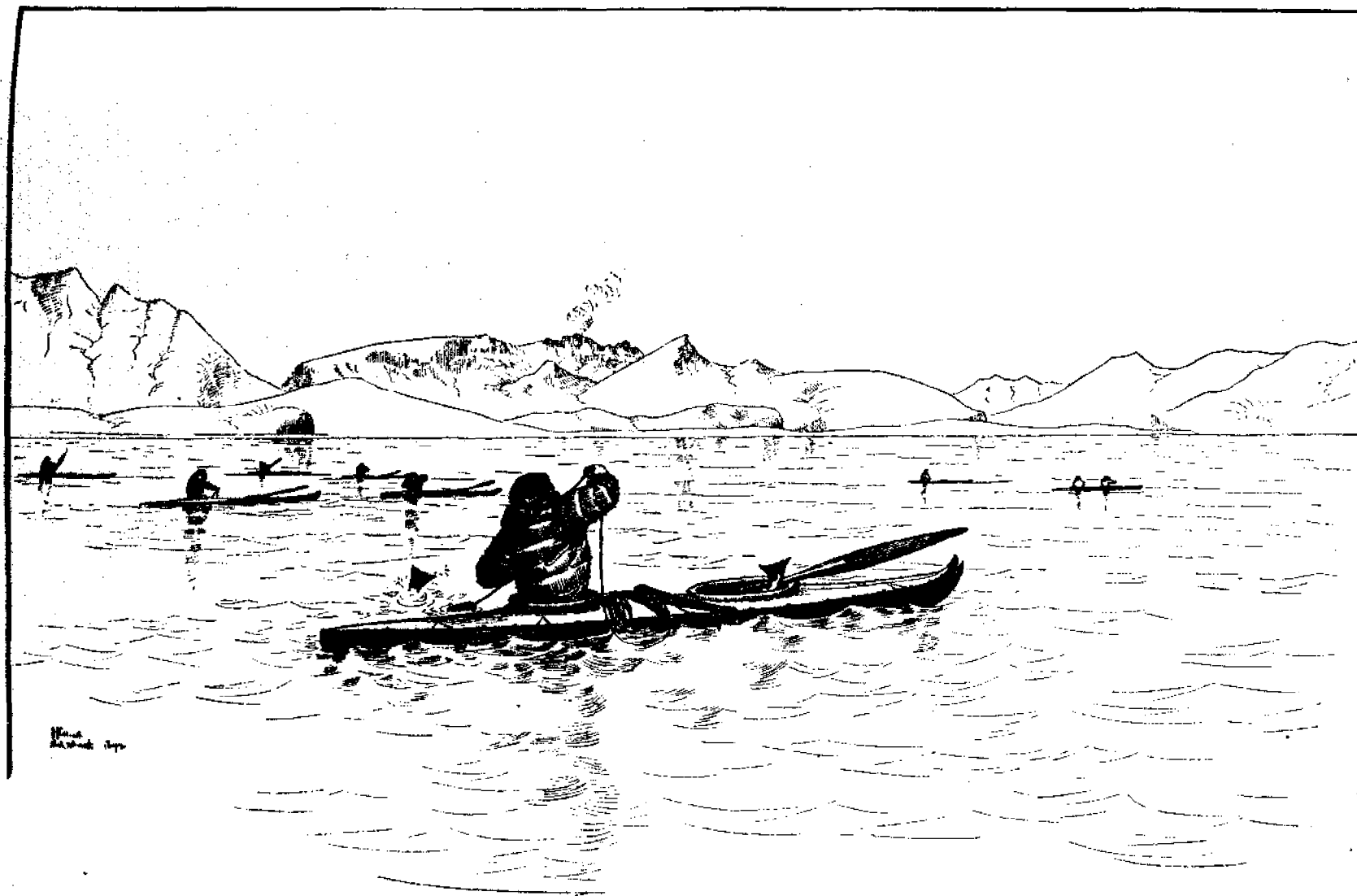

**THE COD FISHERY OF ALASKA.**

Alutians in bidarkies cod-fishing with hand-lines. (Sect. v, vol. i, p. 230.)

Drawing by H. W. Elliott, 1872.



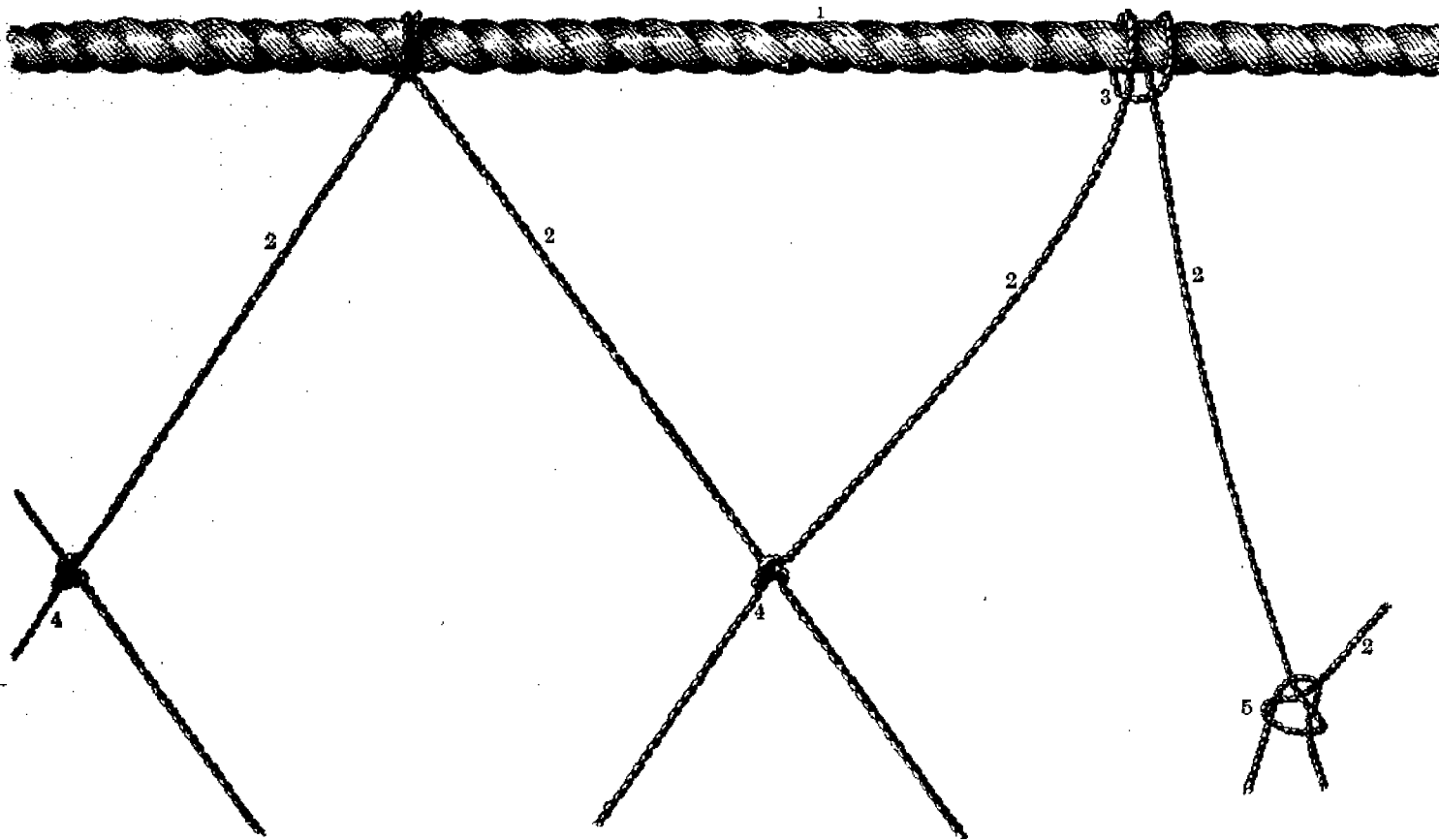

**THE GILL-NET COD FISHERY.**

Method of hanging cod gill-nets. (Sect. v, vol. i, pp. 227, 228.)

1, Hanging rope or line. 2, Hanging twine. 3, Clove-hitch around the rope. 4, Upper part of the net meshes. 5, Open knot, showing how it is made.

Drawing by Capt. J. W. Collins.

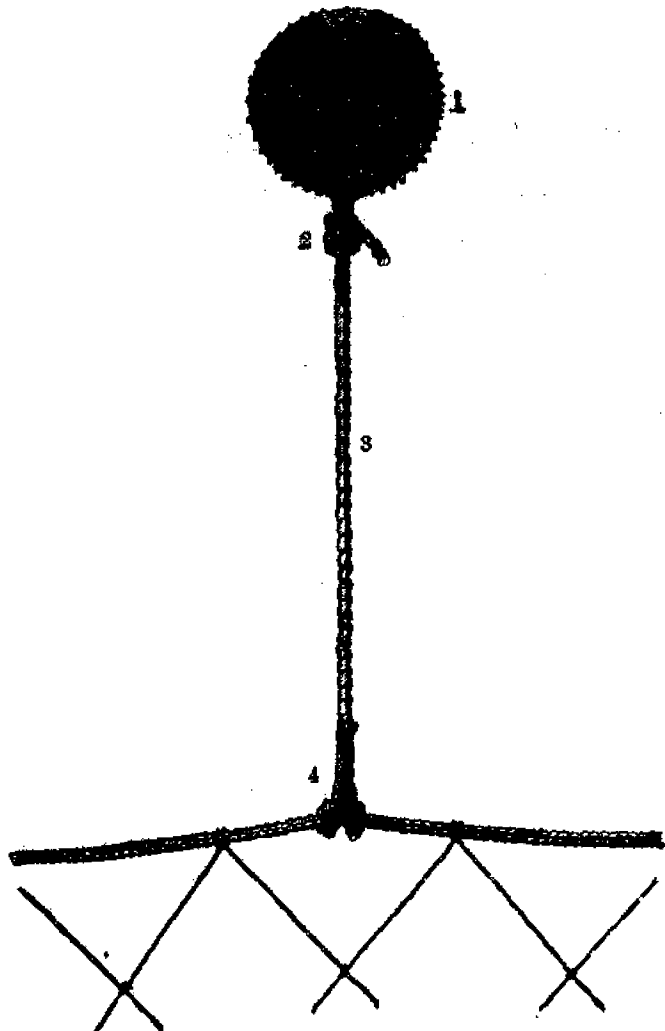

Fig. 1.—Manner in which glass floats are attached to top of nets.

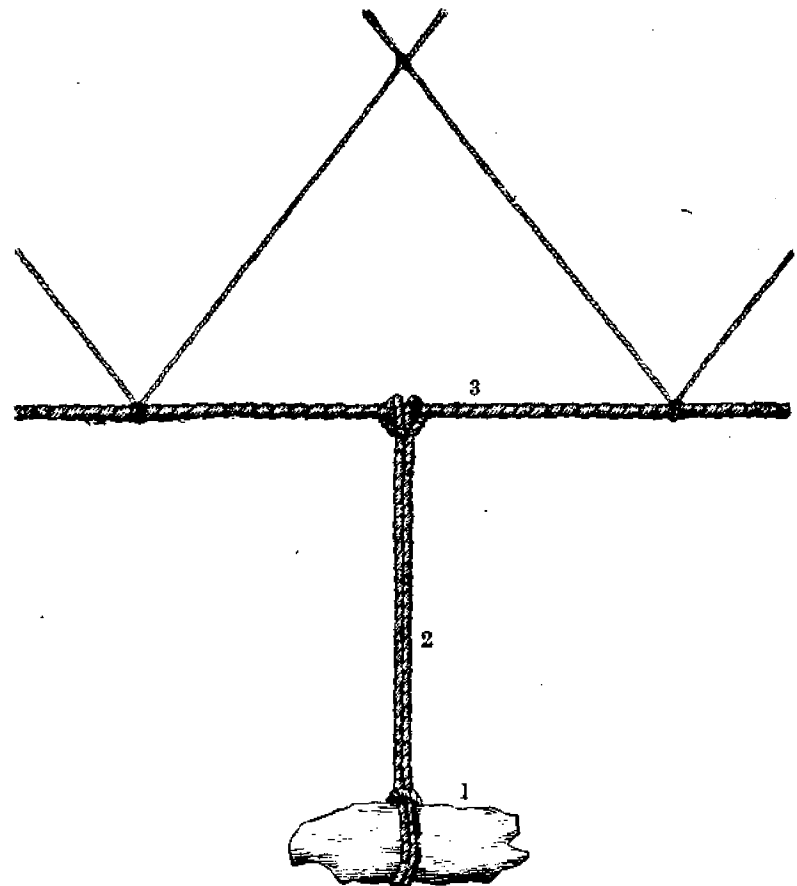
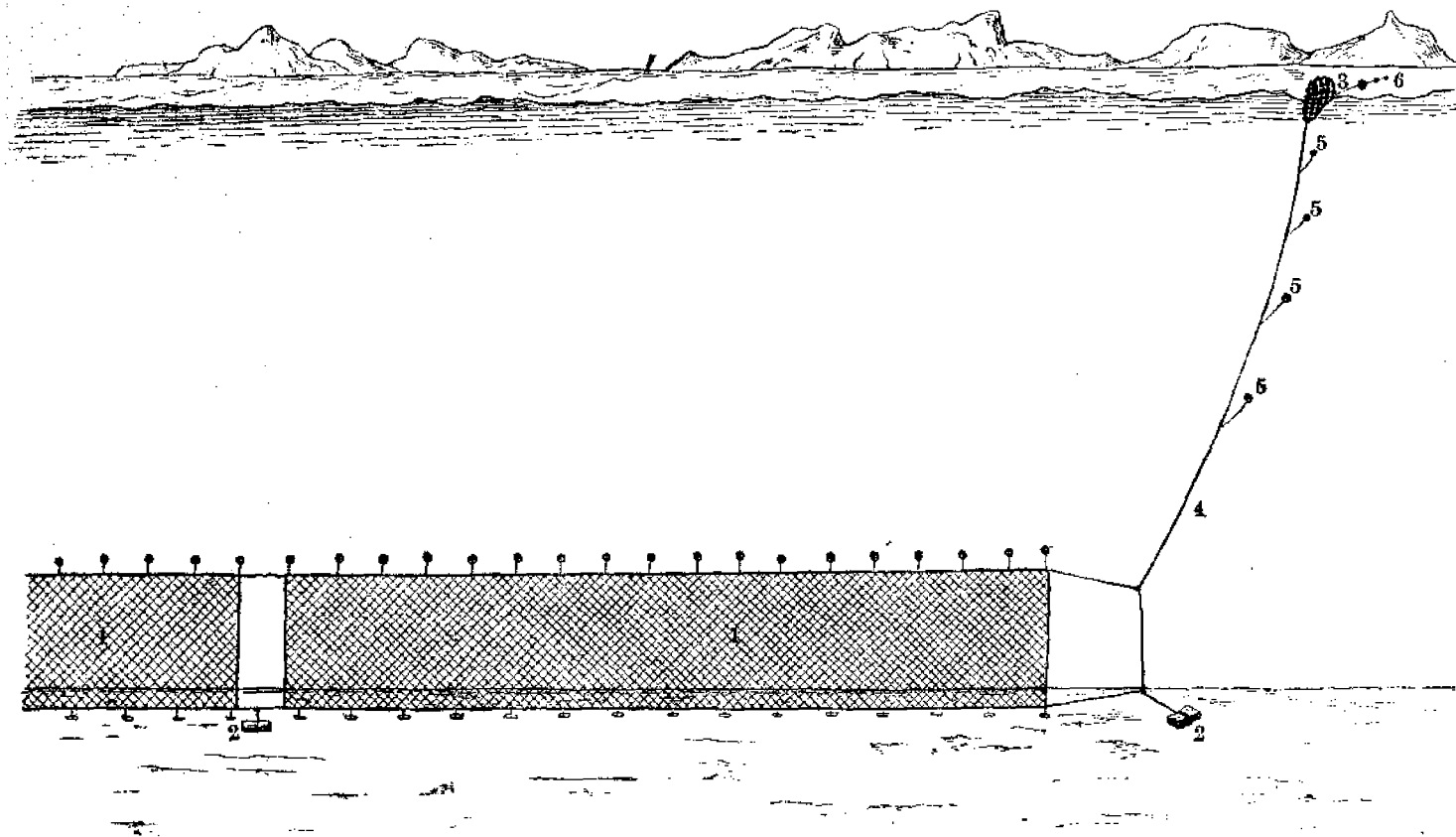

Fig. 2.—Mode of fastening sinkers to foot of nets.

**THE GILL-NET COD FISHERY.**

FIG. 1. 1, Glass float. 2, Eye of the float-covering. 3, Small rope holding the float to the net. 4, Eye-splice in rope, and mode of fastening to net. (Sect. v, vol. i, p. 228.)  
 FIG. 2. 1, Sinker-stone. 2, Double line holding the sinker. 3, Foot of the net. (Sect. v, vol. i, p. 228.)

Drawings by Capt. J. W. Collins.



### THE GILL-NET COD FISHERY.

Norwegian method of setting the nets at the bottom. (Sect. v. vol. i, p. 228.)

1, Nets. 2, Large stones used for moorings. 3, Buoy. 4, Buoy-line. 5, Glass floats attached to buoy-line. 6, Watch-floats.

Drawing by Capt. J. W. Collins.

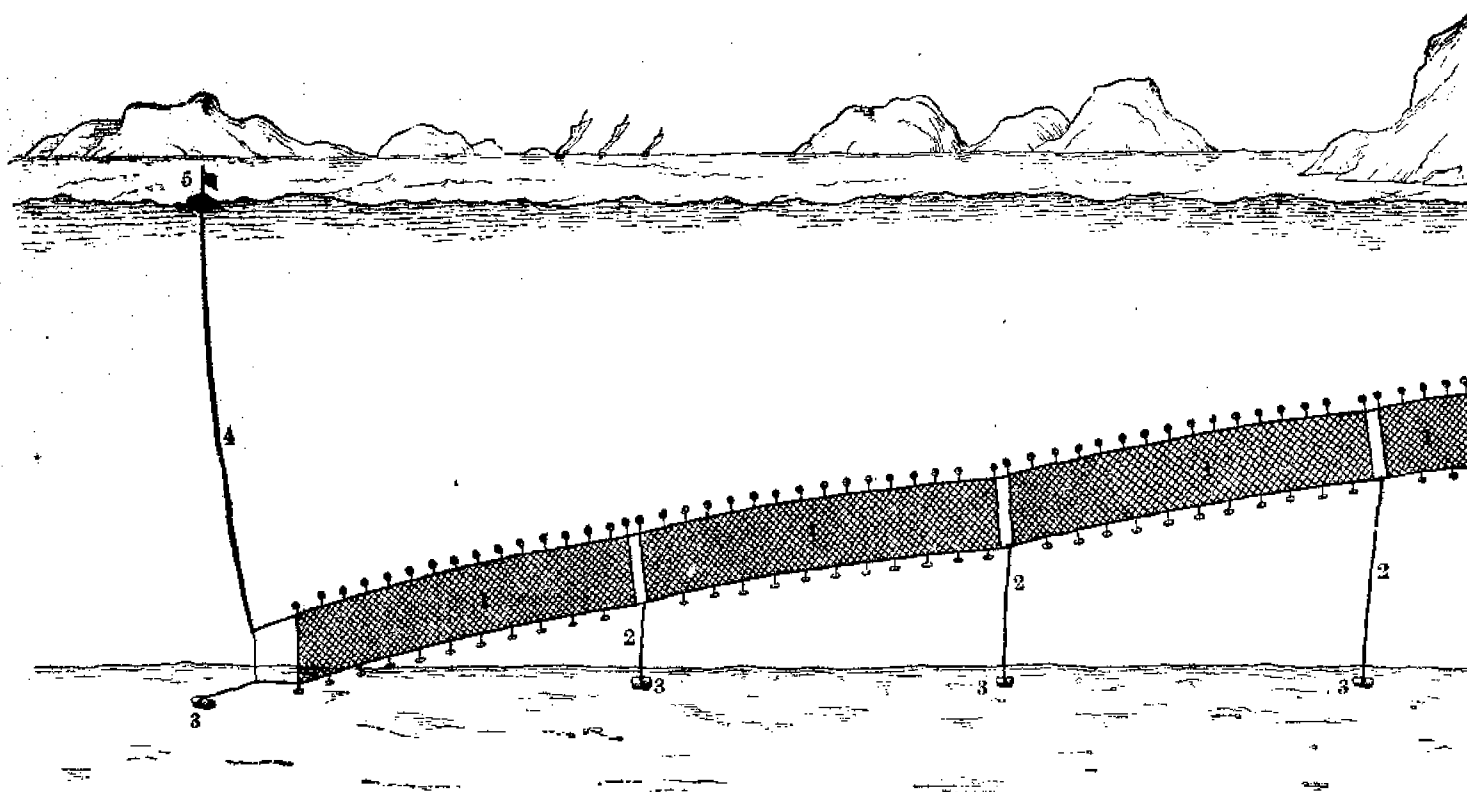

### THE GILL-NET COD FISHERY.

Norwegian method of setting nets at different depths to ascertain the vertical position of the fish. (Sect. v, vol. i, p. 227.)

1, Nets. 2, Foot-lines by which the nets are held to the bottom. 3, Stone moorings to the nets. 4, Buoy-line. 5, Buoy.

Drawing by Capt. J. W. Collins.

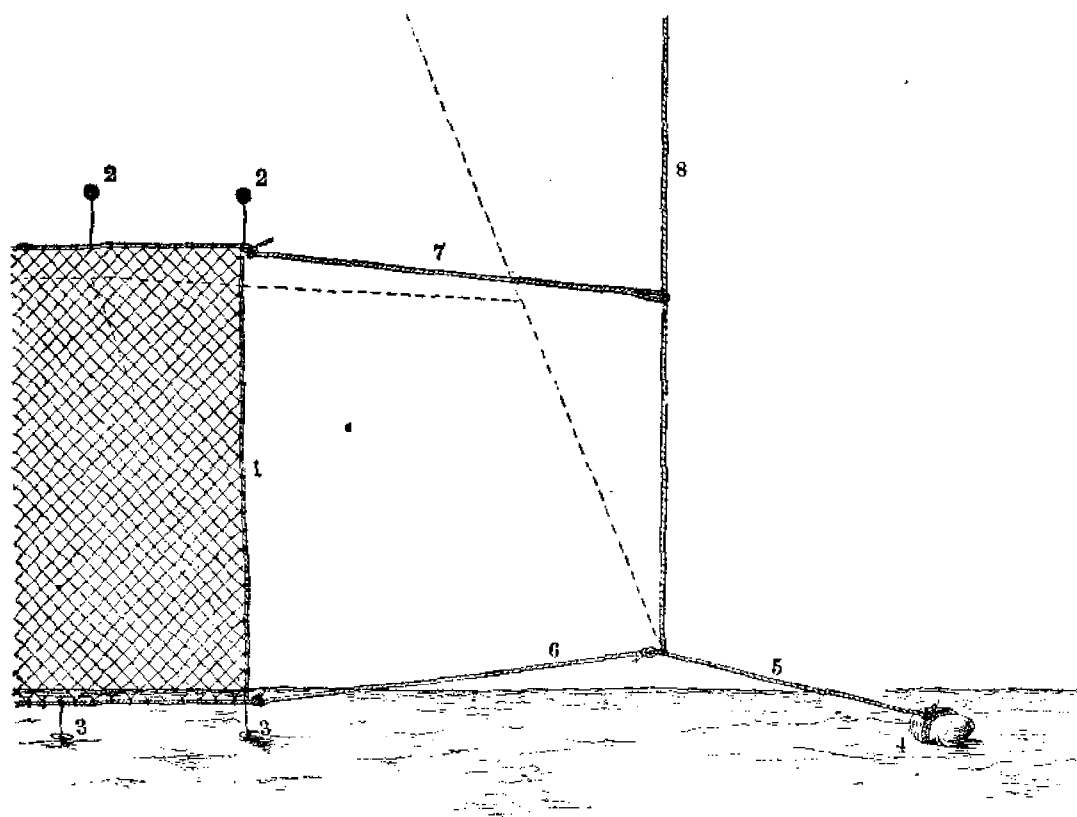

### THE GILL-NET COD FISHERY.

Manner in which the ends of a gang of nets are attached to the stone anchors and buoy-line in Norway; also showing the position of the glass floats and the sinkers. (Sect. v, vol. i, p. 230.)

1, Net. 2, Glass floats. 3, Sinkers. 4, Large stone anchor or mooring. 5, Anchor-line, called foot-line by the Norwegian fishermen. 6, Short rope, one end of which is bent to the lower corner of the net and the other in an eye-splice of the buoy-line. 7, Short rope, one end having an eye-splice in it through which the buoy-line passes, and the other end bent to the upper corner of the net. 8, Buoy-line. The dotted lines show the probable position of the end of the net, buoy-line, &c., when swept back by the current.

Drawing by Capt. J. W. Collins.

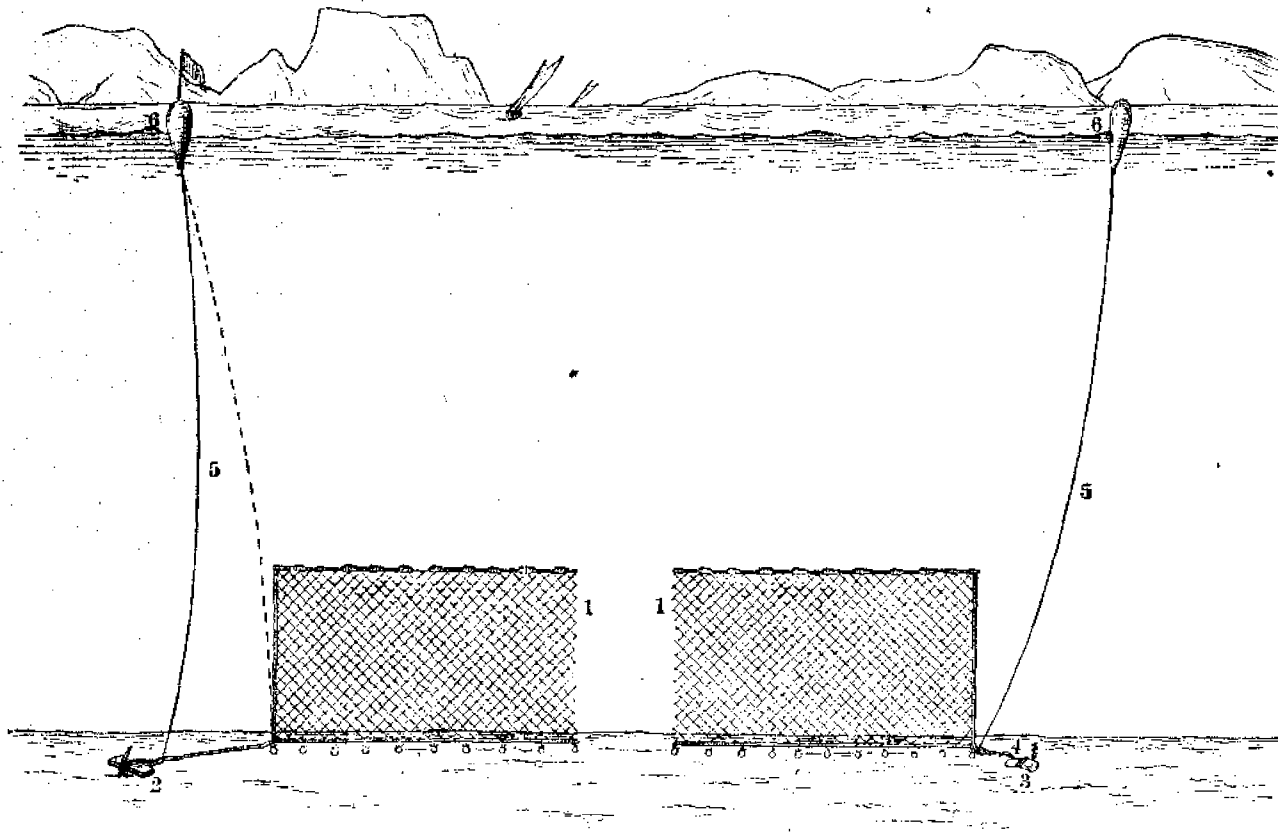

### THE GILL-NET COD FISHERY.

Way in which cod gill-nets are set at the bottom on the east coast of Newfoundland. (Sect. v, vol. i, p. 230.)

1, Ends of the net or gang. 2, Stone killick, generally on the head end of the gang. 3, Stone mooring. 4, Anchor-line, one end of which is bent to lower corner of the net, and the other to the killick or stone mooring. 5, Buoy-line. These are sometimes bent to the killicks, and at other times to the lower corner of the net, as shown by the dotted line. 6, Buoys.

Drawing by Capt. J. W. Collins.

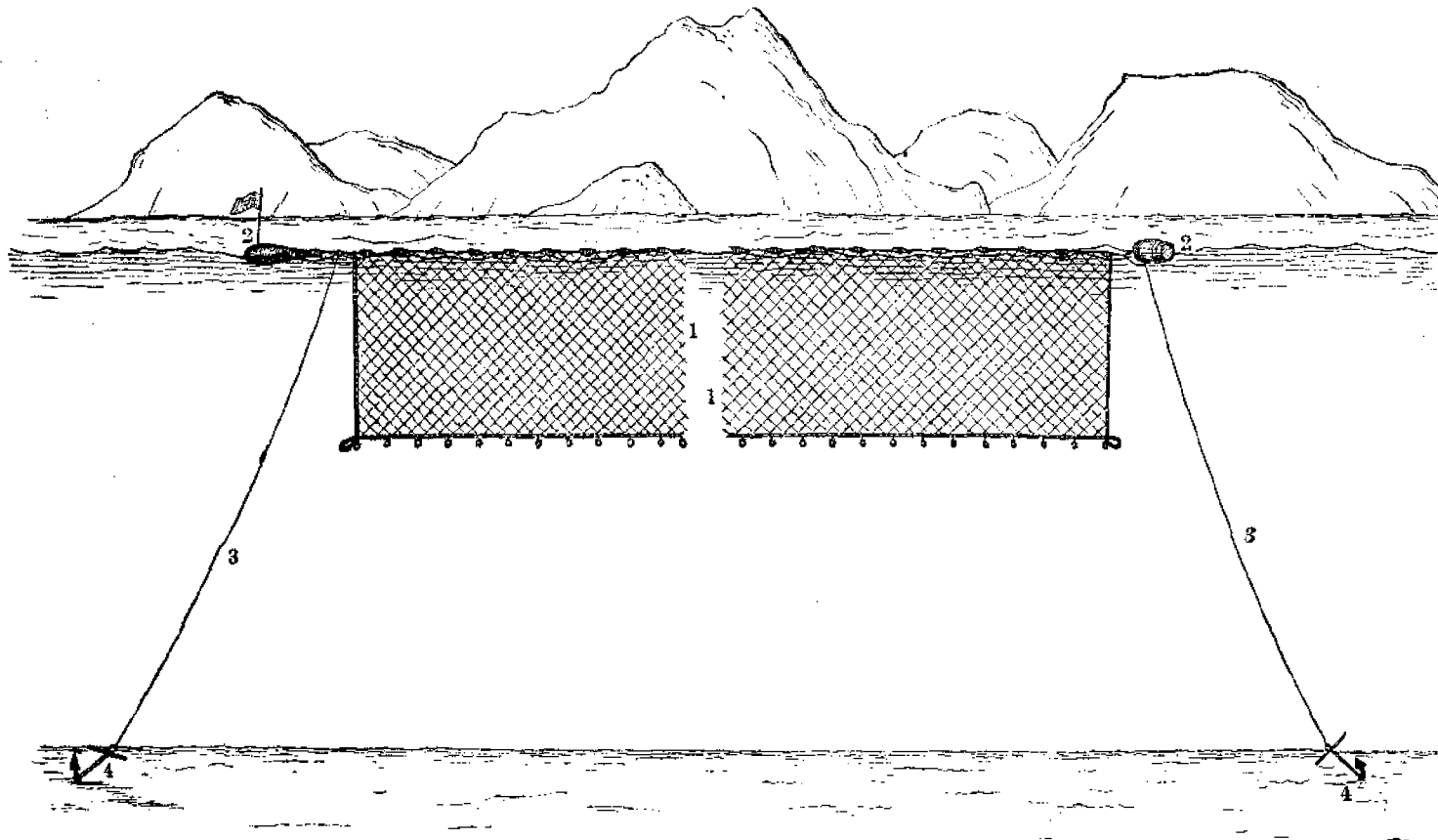

### THE GILL-NET COD FISHERY.

The ordinary way in which cod gill-nets are set floating at Newfoundland. (Sect. v, vol. i, p. 230.)

1, Ends of the net or gang. 2, Buoys. 3, Anchor-lines. 4, Anchors. (Iron anchors, stones, or stone killicks may be used.)

Drawing by Capt. J. W. Collins.

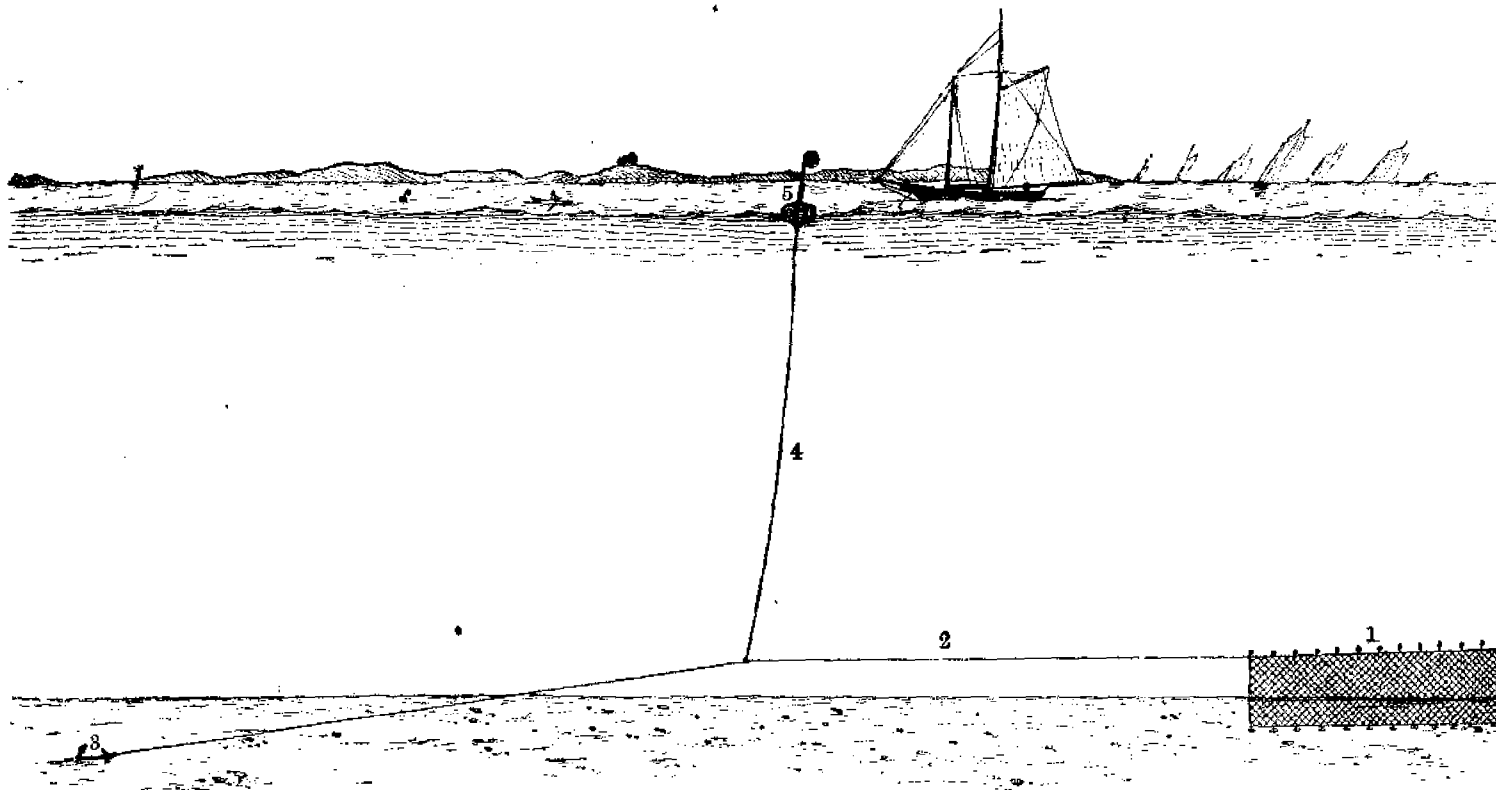

### THE GILL-NET COD FISHERY.

Way in which cod gill-nets are set for underrunning in Ipswich Bay, Mass (Sect. v, vol. i, p. 232.)

1, End of the gang of nets. 2, Anchor-line, also called the "underrunning line." 3, Anchor. 4, Buoy-line. 5, Buoy.

Drawing by Capt. J. W. Collins.



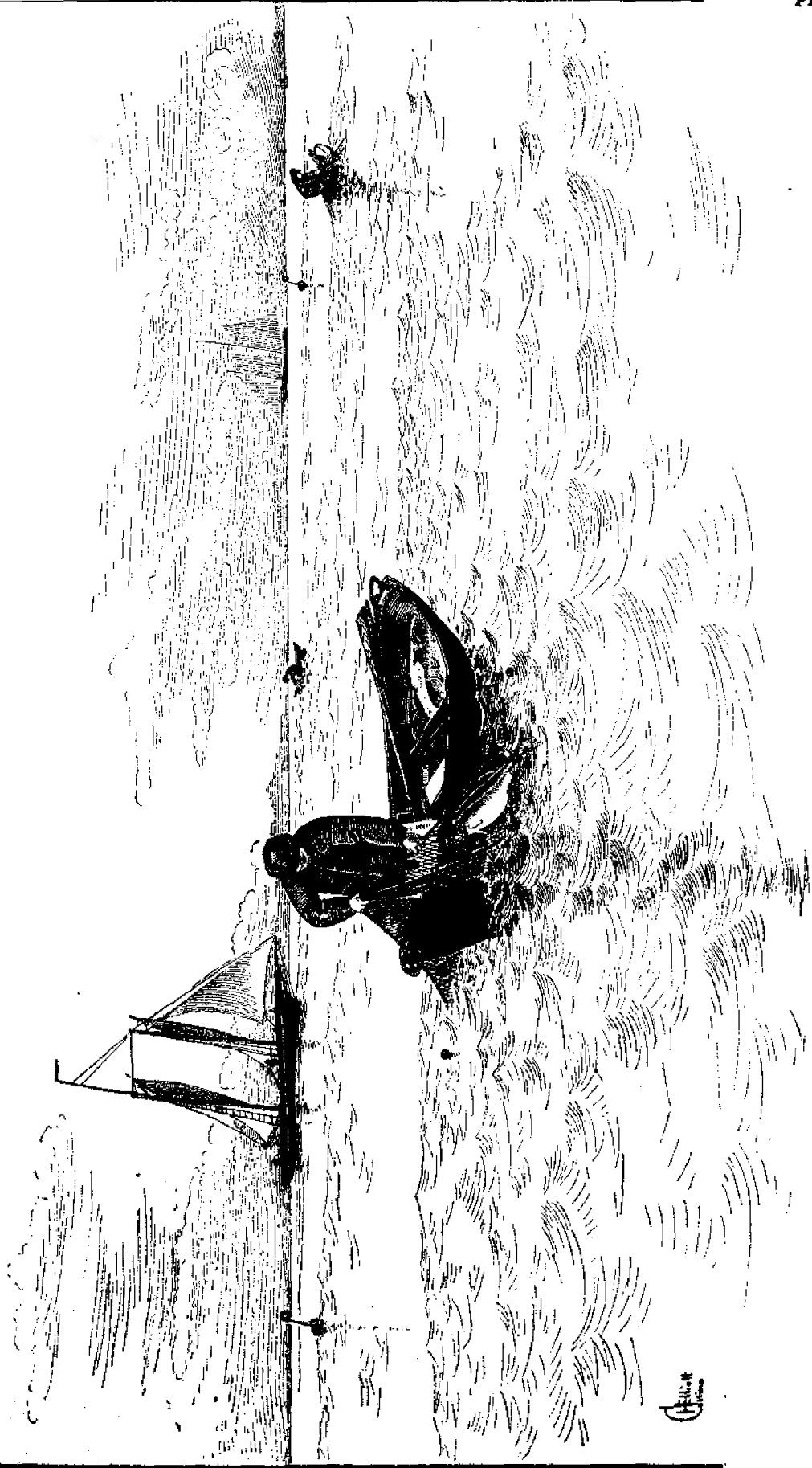

**THE GILL-NET COD FISHERY.**

Underrunning cod gill-nets in Ipswich Bay, Mass. (Sect. v, vol. i, p. 232.)

Drawing by H. W. Elliott and Capt. J. W. Collins.

*H. W. Elliott*  
1882

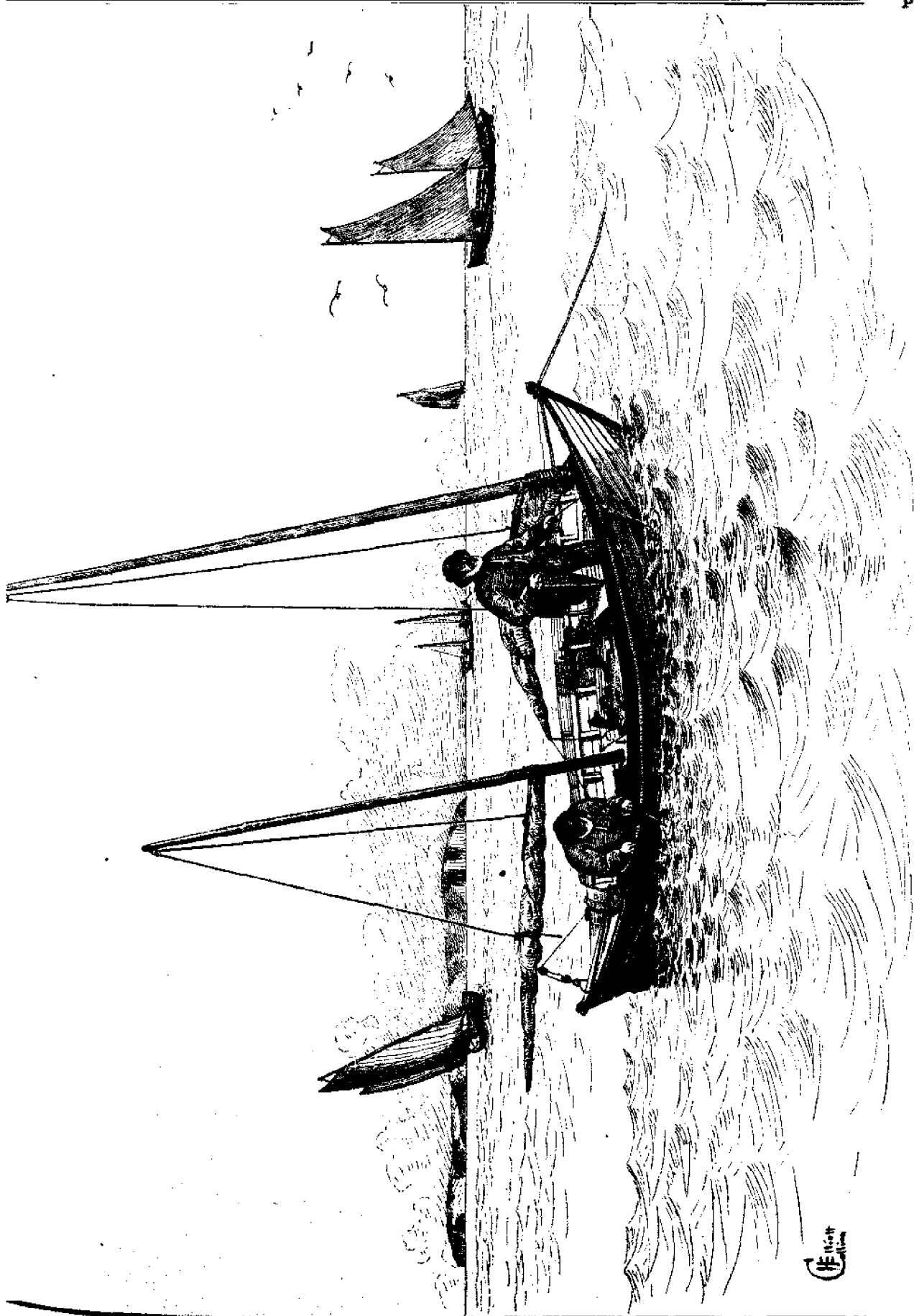

**THE SHORE COD FISHERY.**

Block Island boat and crew hand-lipping for cod. (Sect. v, vol. i.)

Drawing by H. W. Elliott and Capt. J. W. Collins.





**THE SHORE COD FISHERY.**

Pink-stern schooner and boats hand-line fishing off Cape Ann, Mass. (Sect. v, vol. i.)

From a photograph by T. W. Snillie.



**THE HADDOCK FISHERY.**

Baiting trawls on deck of Gloucester haddock schooner Mystic. (Sect. v, vol. i, p. 237.)

From a photograph by T. W. Shullin.

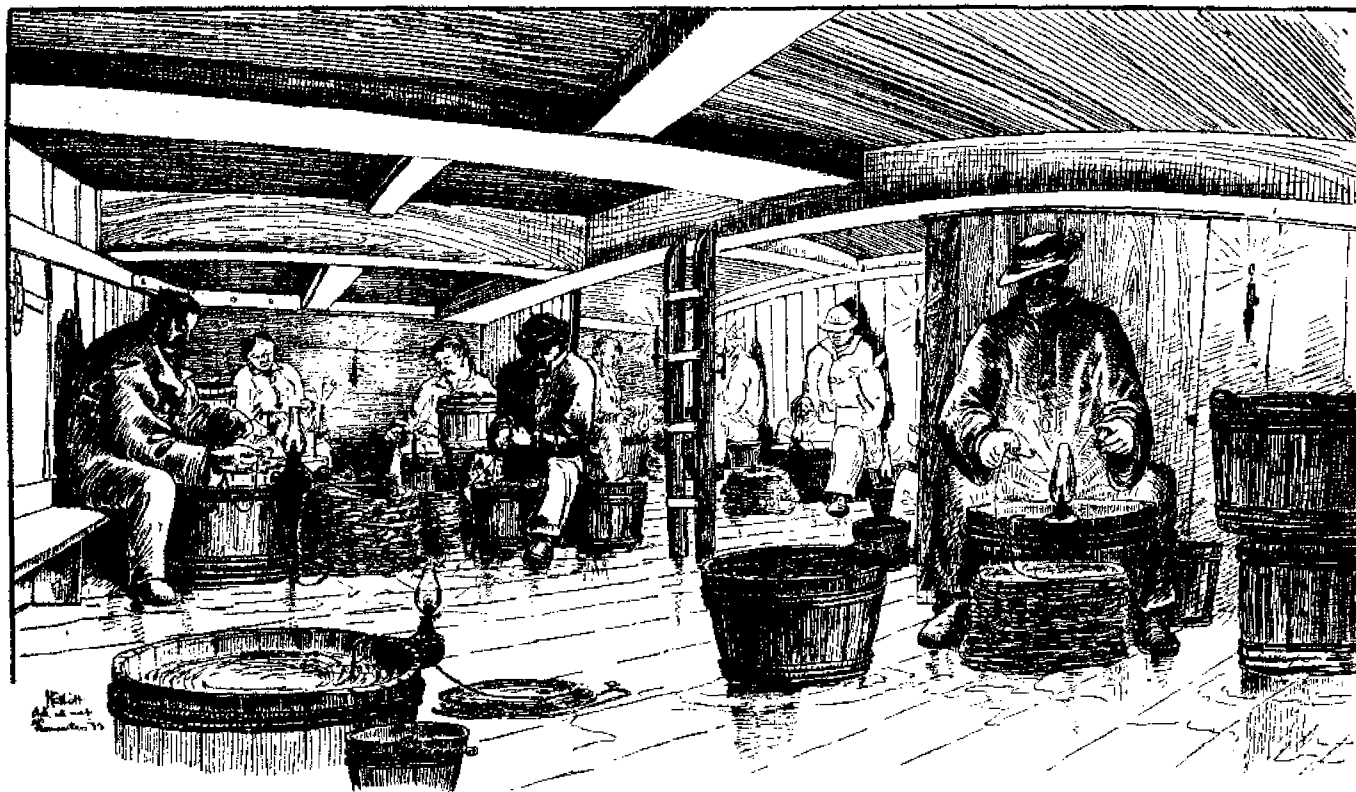

**THE HADDOCK FISHERY.**

Baiting trawls at night in hold of haddock schooner. (Sect. v, vol. i, p. 237.)

Drawing by H. W. Elliott.

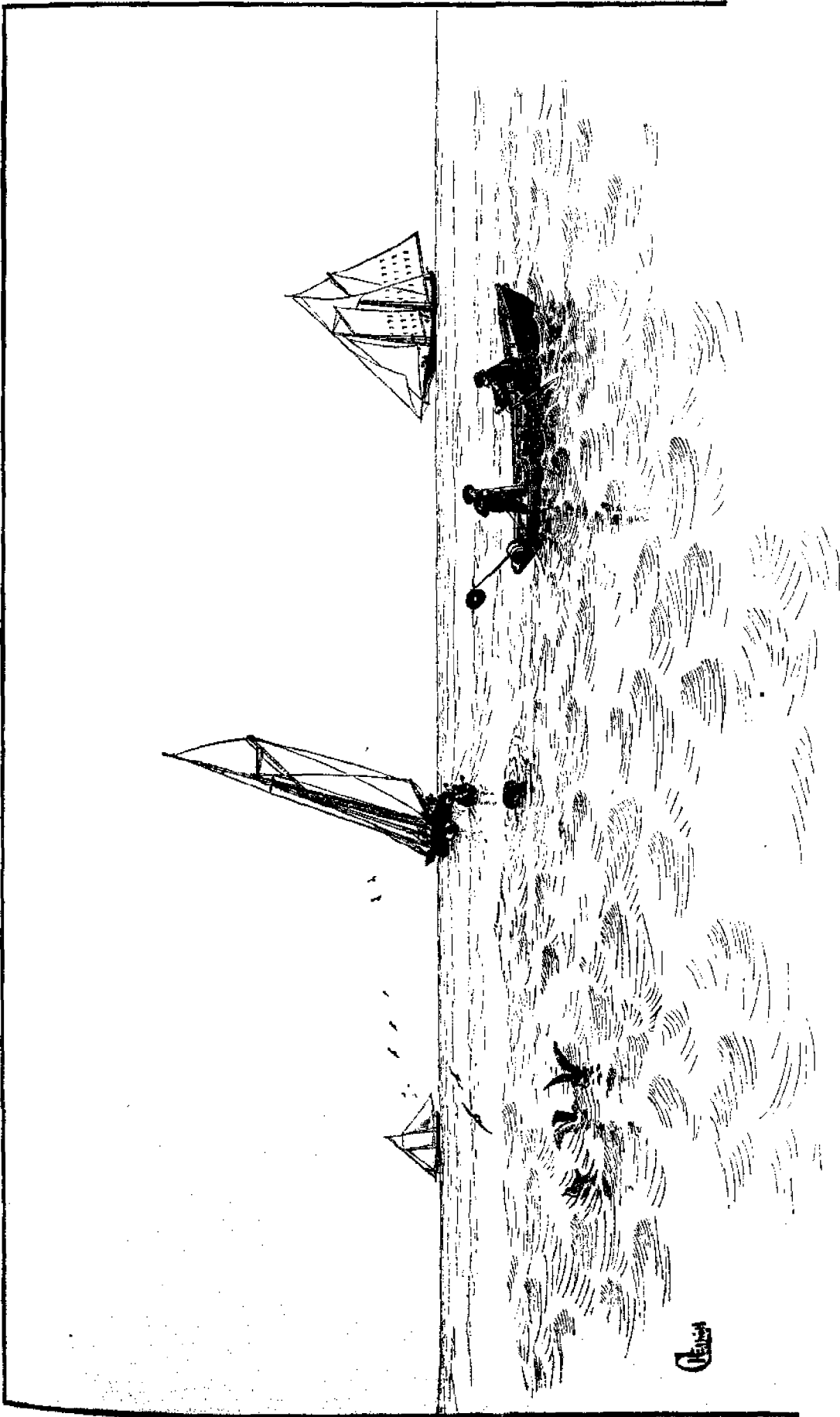

**THE HADDOCK FISHERY.**

Setting haddock trawls from schooner under sail; set at right angles to course of the vessel. (Sect. v, vol. i, p. 235.)

Drawing by H. W. Elliott and Capt. J. W. Collins.

Clayton

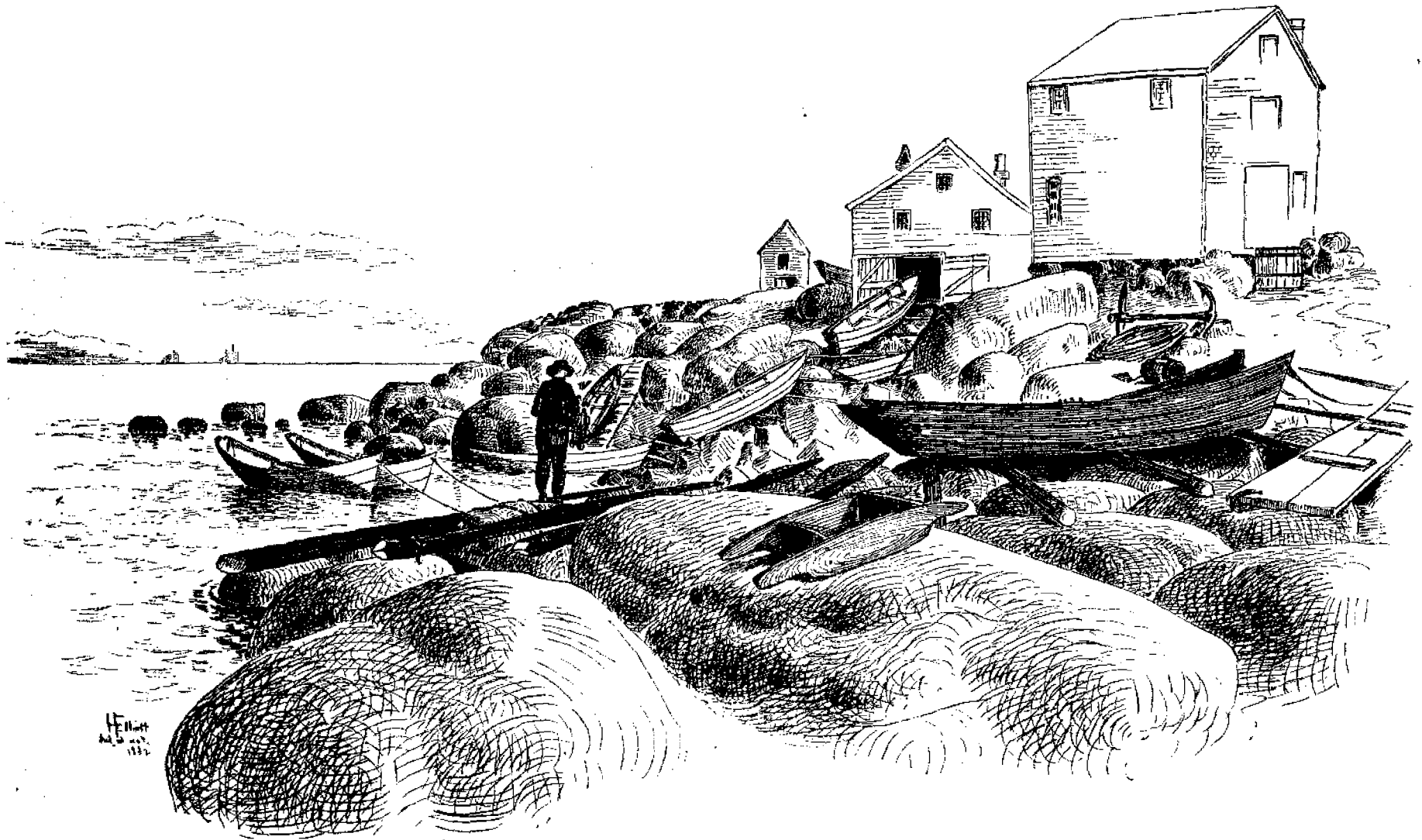

**THE HAKE FISHERY.**

Fishermen's deries on the rocks at Folly Cove, Cape Ann, Mass. (Sect. v, vol. i, p. 211.)

Drawing by H. W. Elliott.

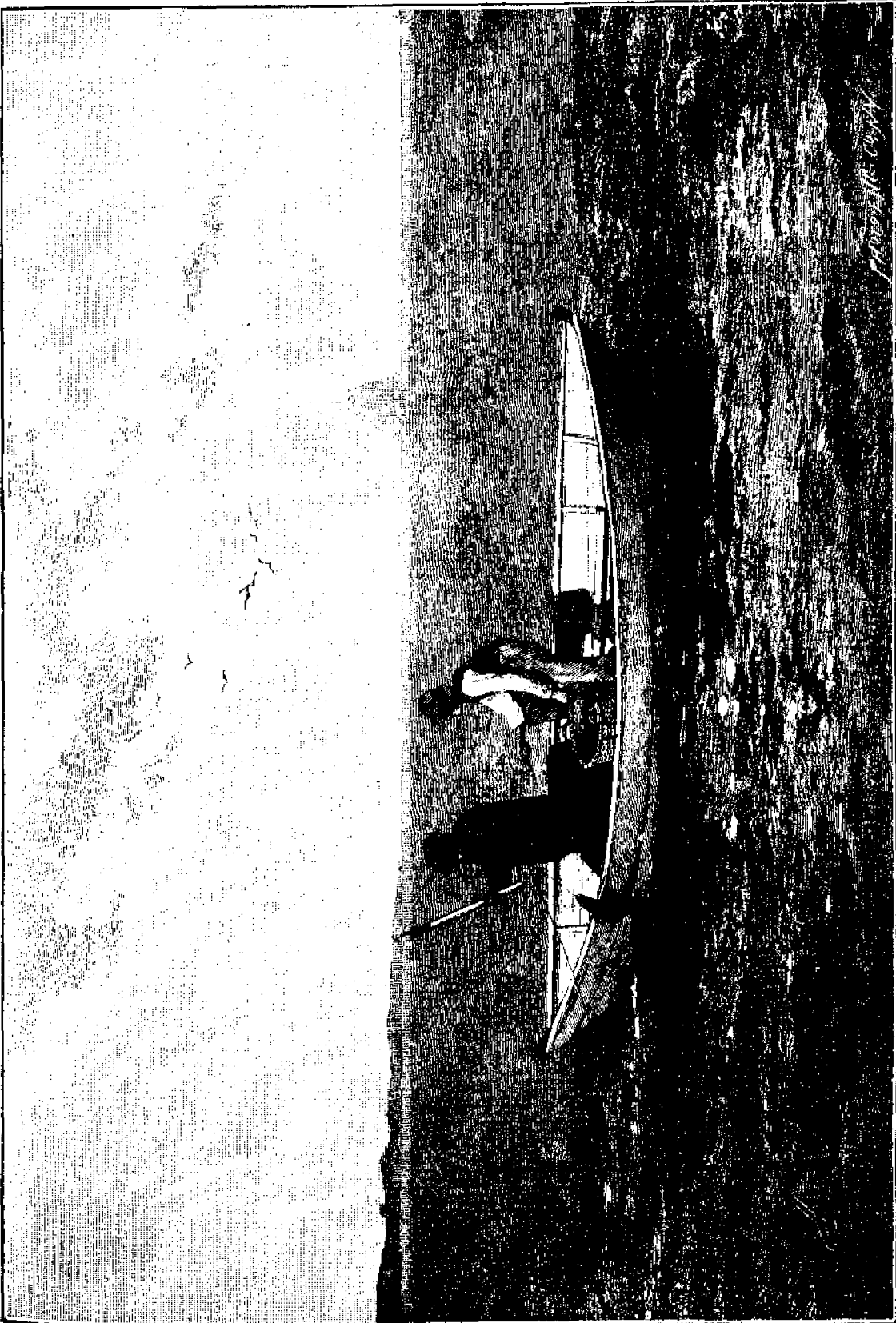

**THE HAKE FISHERY.**

Fishermen in dory hauling the trawl; a dogfish caught. (Sect. v, vol. i, p. 242.)

From a photograph by T. W. Smilie.





**THE HAKE FISHERY.**

Overhauling the trawls in fish-house at Rockport, Mass. (Sect. v, vol. i, p. 212.)

Drawing by H. W. Edner

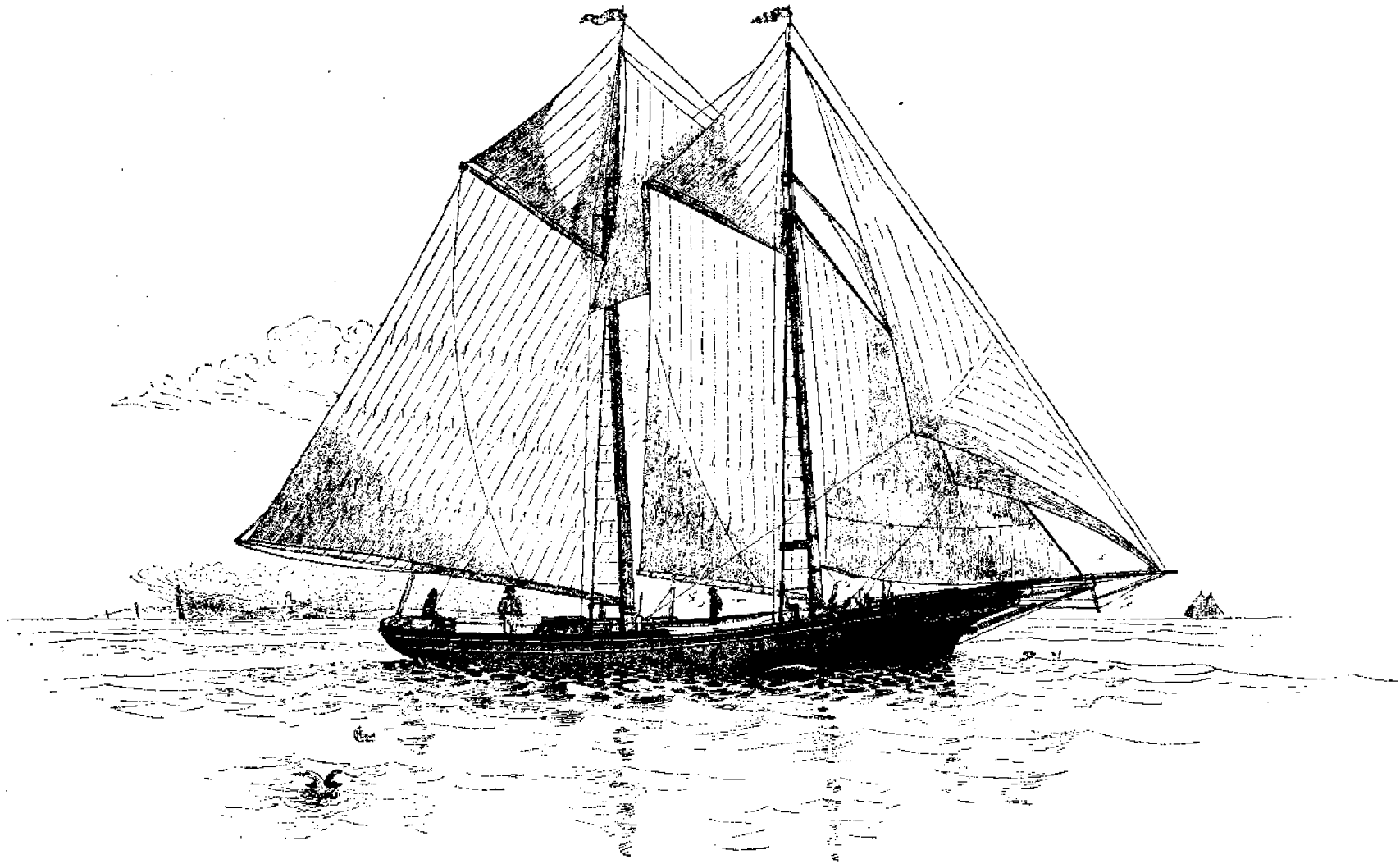

**THE MACKEREL PURSE-SEINE FISHERY.**

Mackerel schooner under full sail, bound out. (Sect. v, vol. i, p. 248.)

Drawing by H. W. Elliott and Capt. J. W. Collins.



**THE MACKEREL PURSE-SEINE FISHERY.**

The cabin of mackerel schooner John D. Long, of Gloucester, Mass. (Sect. v, vol. 4, p. 247.)

Drawing by H. W. Elliott.

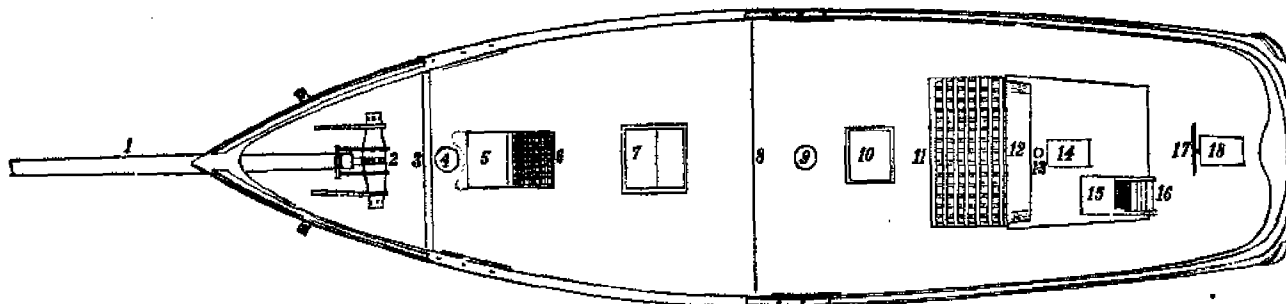

**THE MACKEREL PURSE-SEINE FISHERY.**

Deck plan of schooner: 1, bowsprit; 2, windlass; 3, jib-sheet traveller; 4, foremast; 5, fore companion; 6, fore-hatch grating; 7, main-hatch; 8, brake of quarter deck; 9, mainmast; 10, after-hatch; 11, grating to stow seines on; 12, barrel-head box; 13, stove-pipe; 14, skylight; 15, cabin companion-slide; 16, companion stairs; 17, steering wheel; 18, wheel-box. (Sect. v, vol. i, p. 248.)

Drawing by Capt. J. W. Collins.

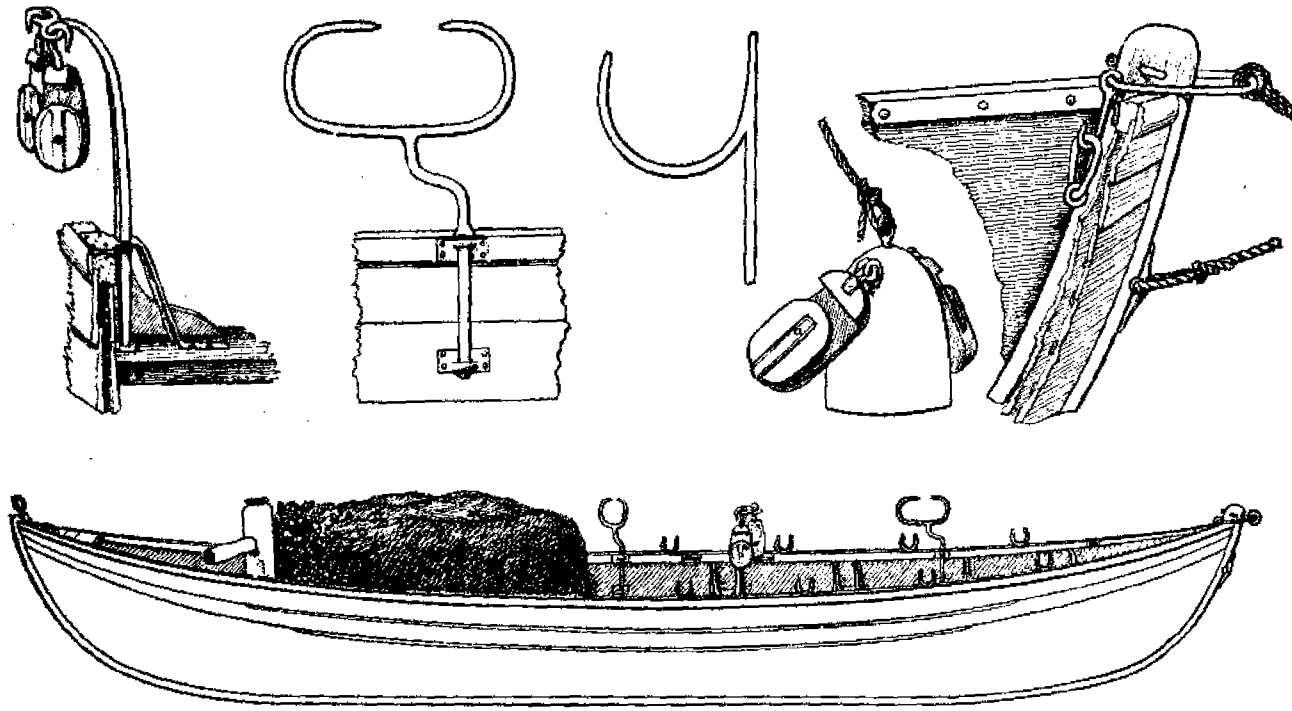

**THE MACKEREL PURSE-SEINE FISHERY.**

Seine boat; purse davit and blocks; oar-rests; purse weight and purse blocks; bow-fittings. (Sect. v, vol. i, p. 250.)

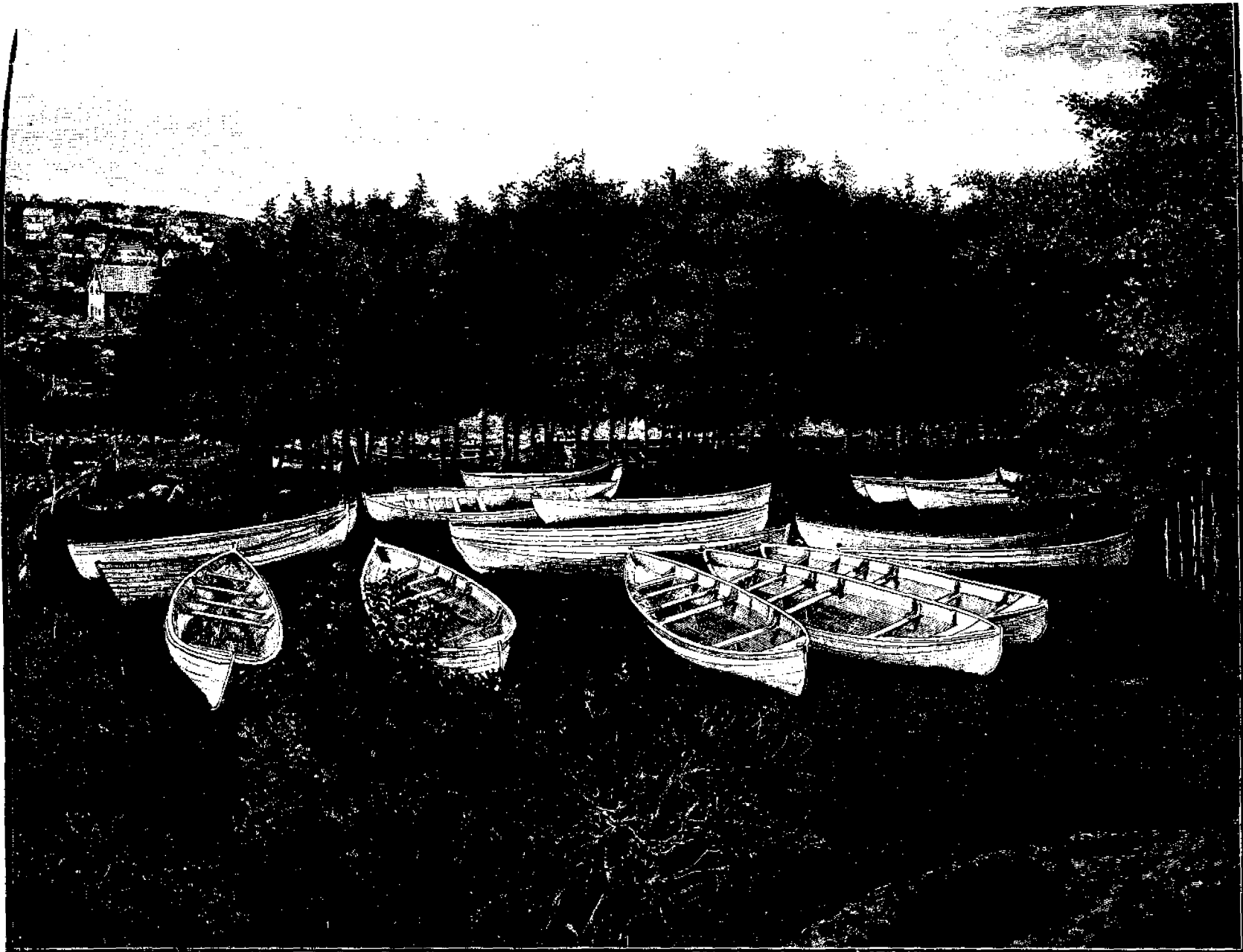

**THE MACKEREL PURSE-SEINE FISHERY.**

Seine-boats in winter-quarters at Gloucester, Mass. (Sect. v, vol. i, p. 250.)

From a photograph by T. W. Smillie.

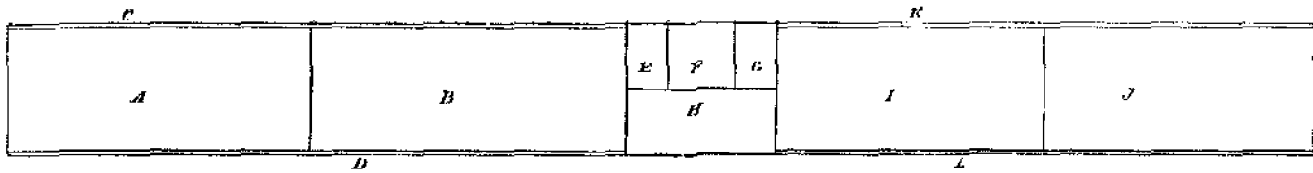

Fig. 1.

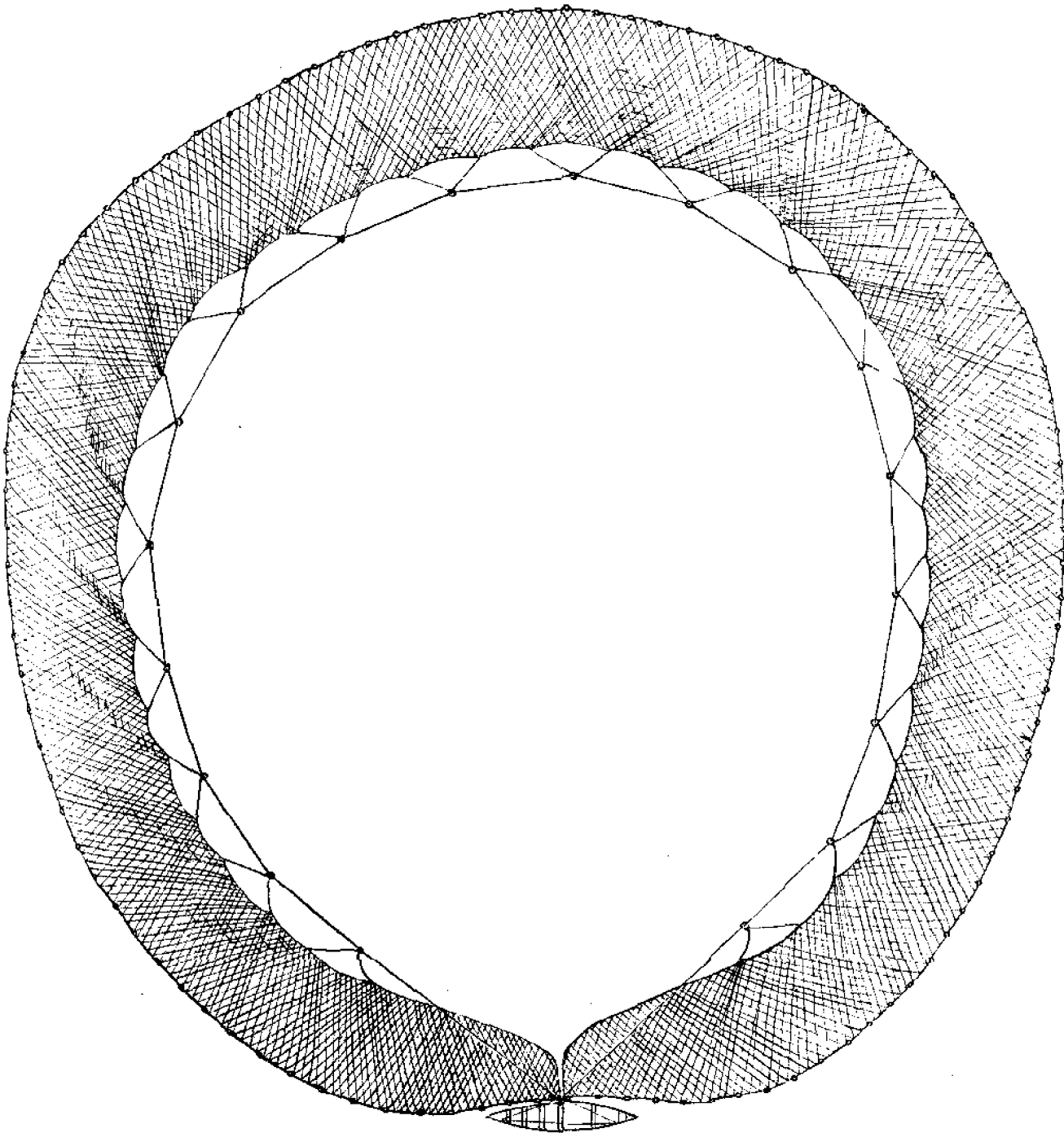

Fig. 2.

**THE MACKEREL PURSE-SEINE FISHERY.**

FIG. 1. Diagram showing the different sections of a purse-seine: *A* and *J*, arms of net; *B* and *I*, wings; *C*, *D*, *K*, and *L*, border of stout twine; *E*, bailing piece or bunt; *E* and *G*, sides; *H*, under.

FIG. 2. Diagram showing the form of a purse-seine when spread in the water. (Sect. v, vol. i, p. 252.)

Drawings by Capt. J. W. Collins.

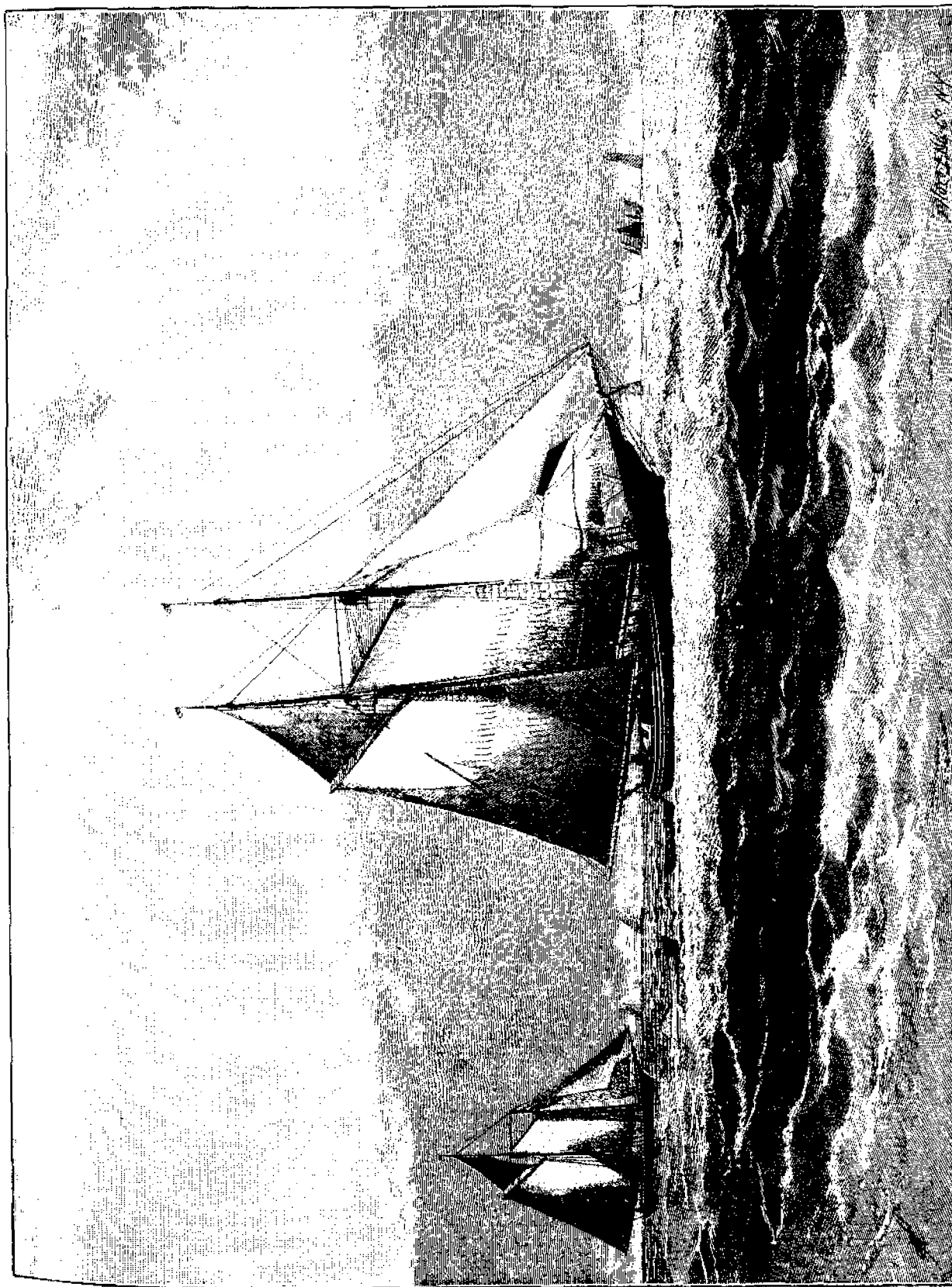

**THE MACKEREL PURSE-SEINE FISHERY.**

Mackerel schooner cruising in Massachusetts Bay, lookout at foremast head on the watch for schools (Sect. V, vol. I, p. 255.)

From a photograph by T. W. Suttler.



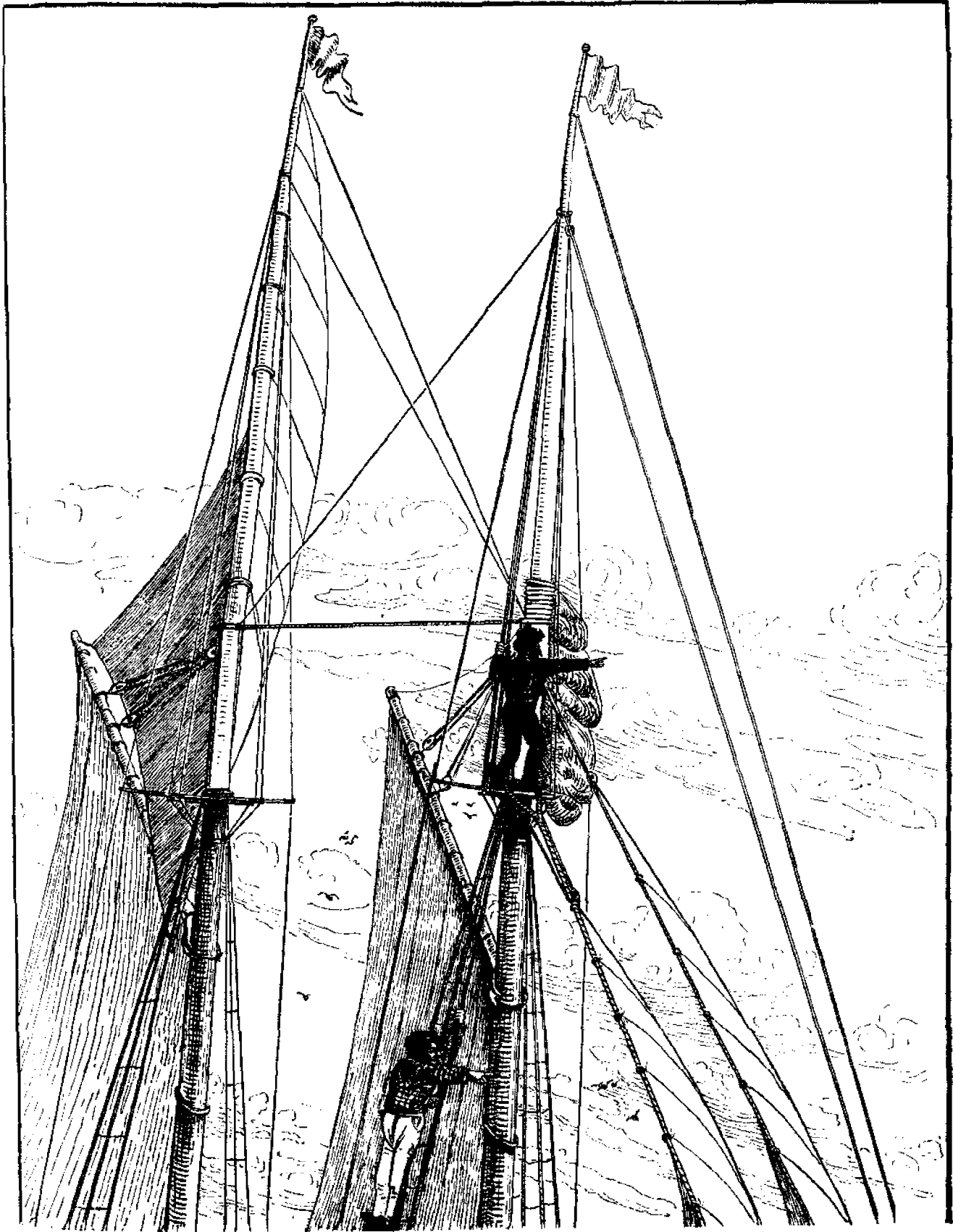

**THE MACKEREL PURSE-SEINE FISHERY.**

Lookouts aloft on schooner on the watch for mackerel. (Sect. v, vol. 1, p. 255.)

Drawing by H. W. Elliott and Capt. J. W. Collins.

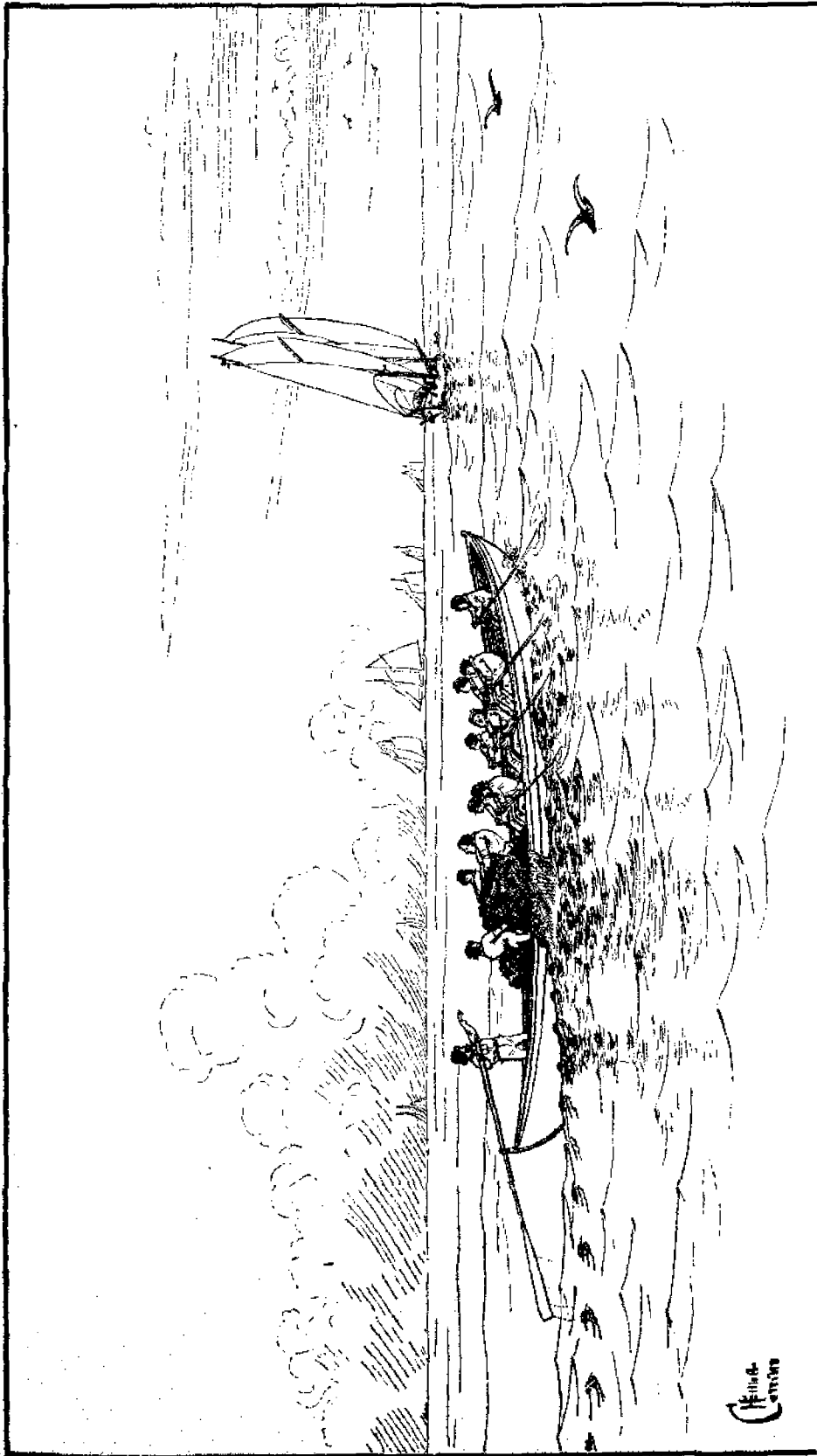

**THE MACKEREL PURSE-SEINE FISHERY.**

Seine-boat and crew "paying out" the seine. (Sect. v, vol. i, p. 256.)

Drawing by H. W. Elliott and Capt. J. W. Collins.

Heine  
Littor

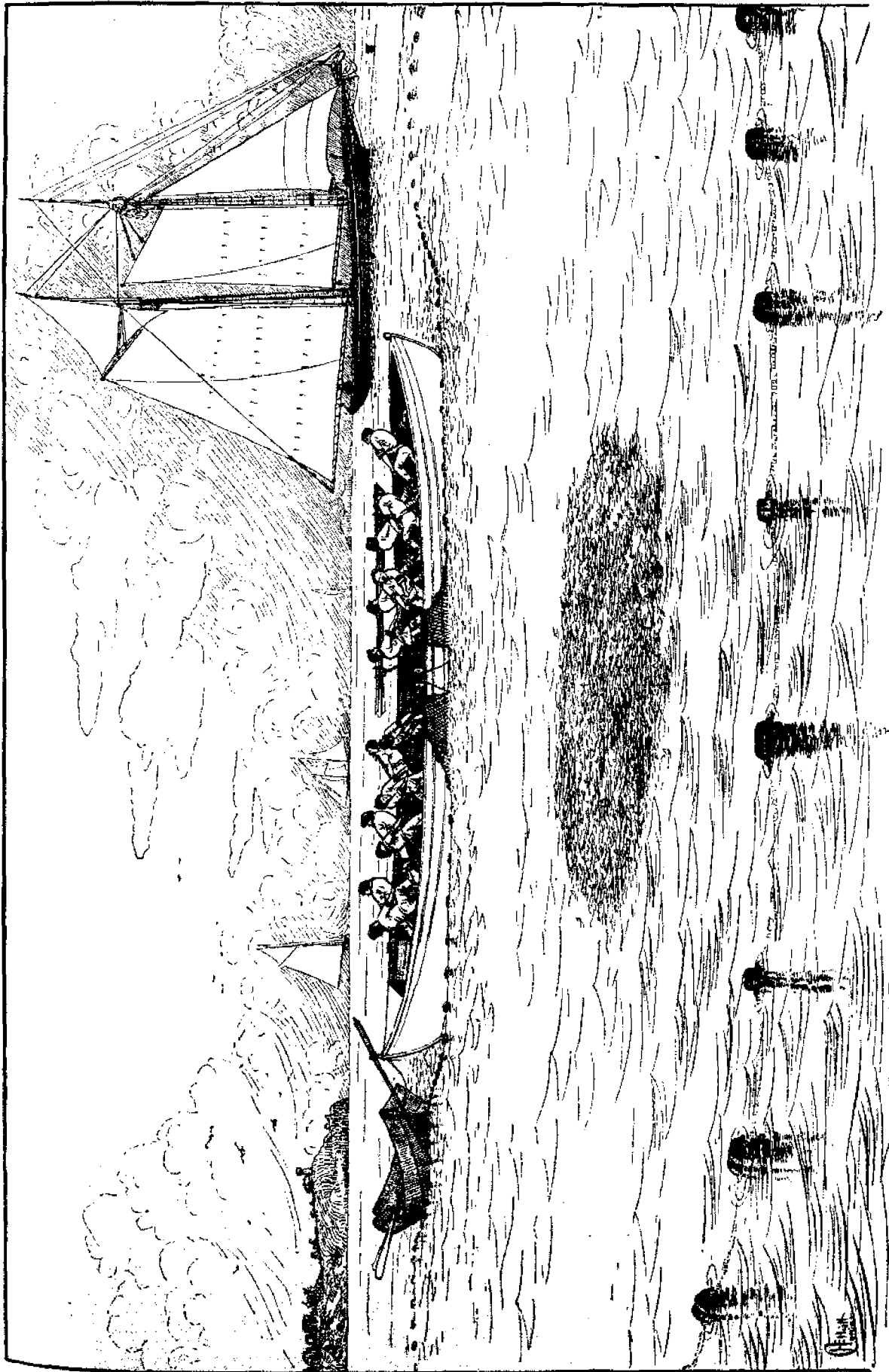

**THE MACKEREL PURSE-SEINE FISHERY.**

Seine-boat and crew "pursing the seine." (Sect. v, vol. 1, p. 356.)

Drawing by H. W. Elliott and Capt. J. W. Collins.

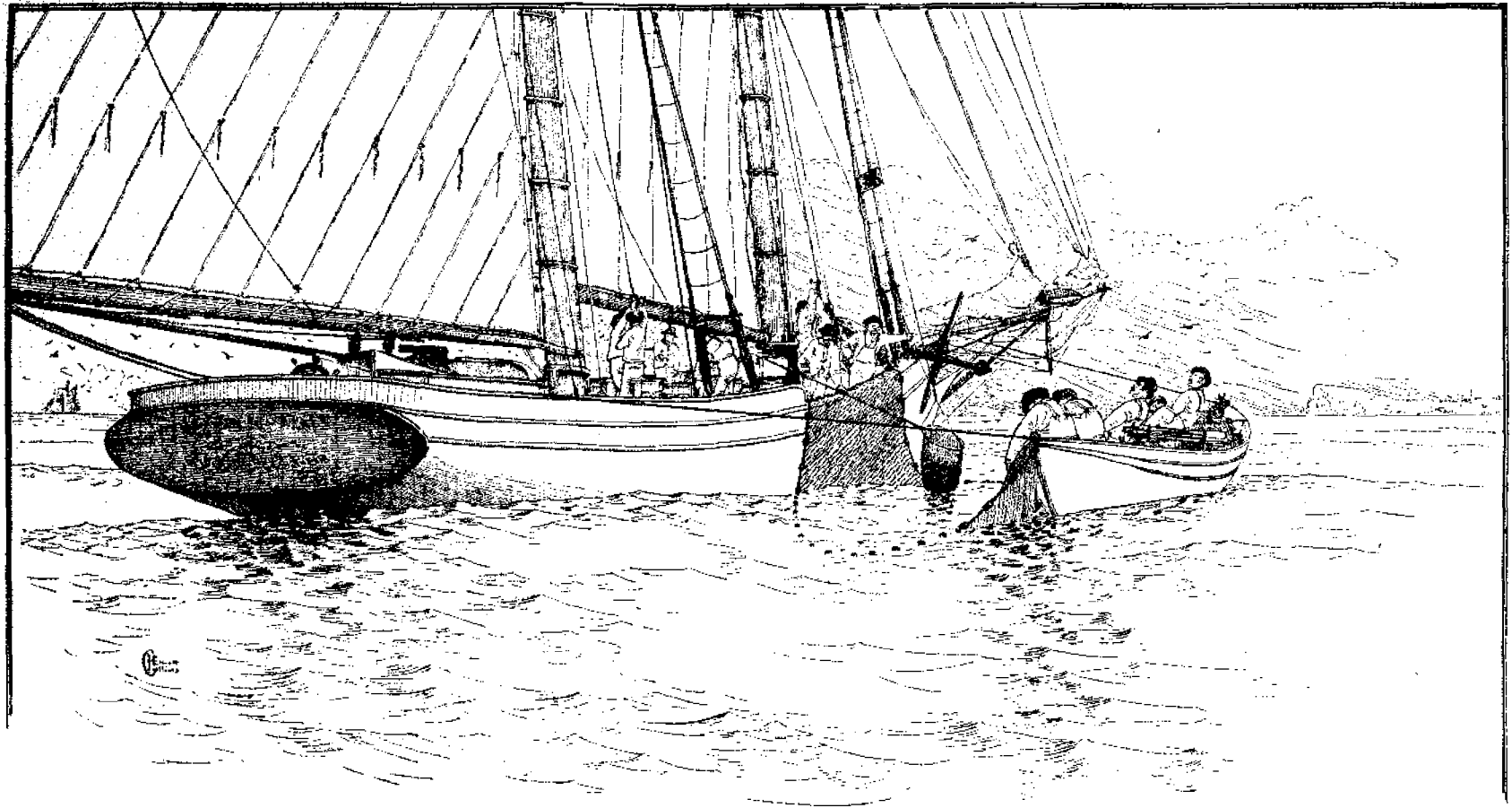

**THE MACKEREL PURSE-SEINE FISHERY.**

Schooner with crew at work bailing mackerel from the purse-seine. (Sect. v, vol. i, p. 258.)

Drawing by H. W. Elliott and Capt. J. W. Collins.

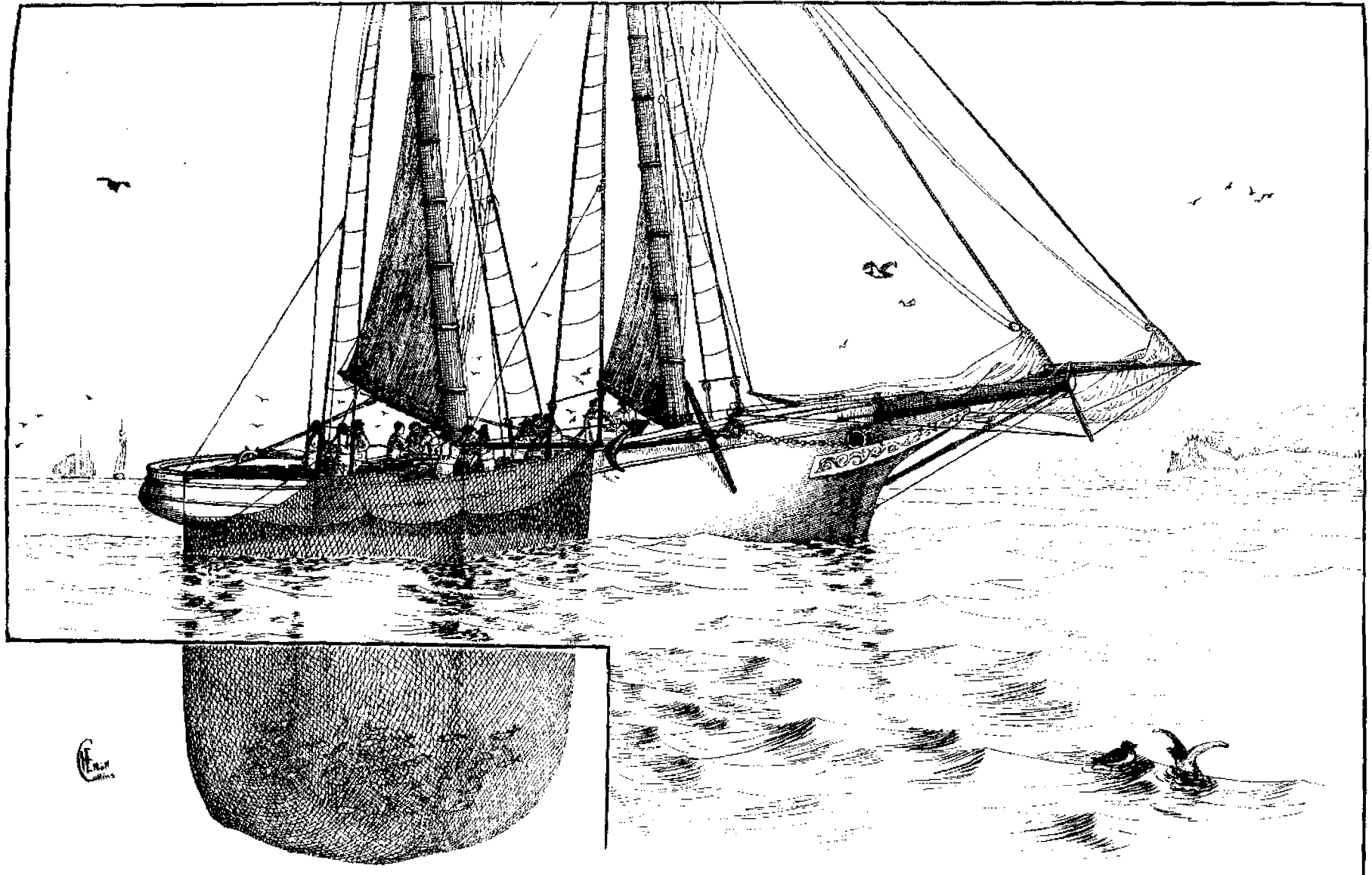

**THE MACKEREL PURSE-SEINE FISHERY.**

Schooner with mackerel pocket, or spiller, shipped at sea. (Sect. v, vol. i, p. 265.)

Drawing by H. W. Elliott and Capt. J. W. Collins.

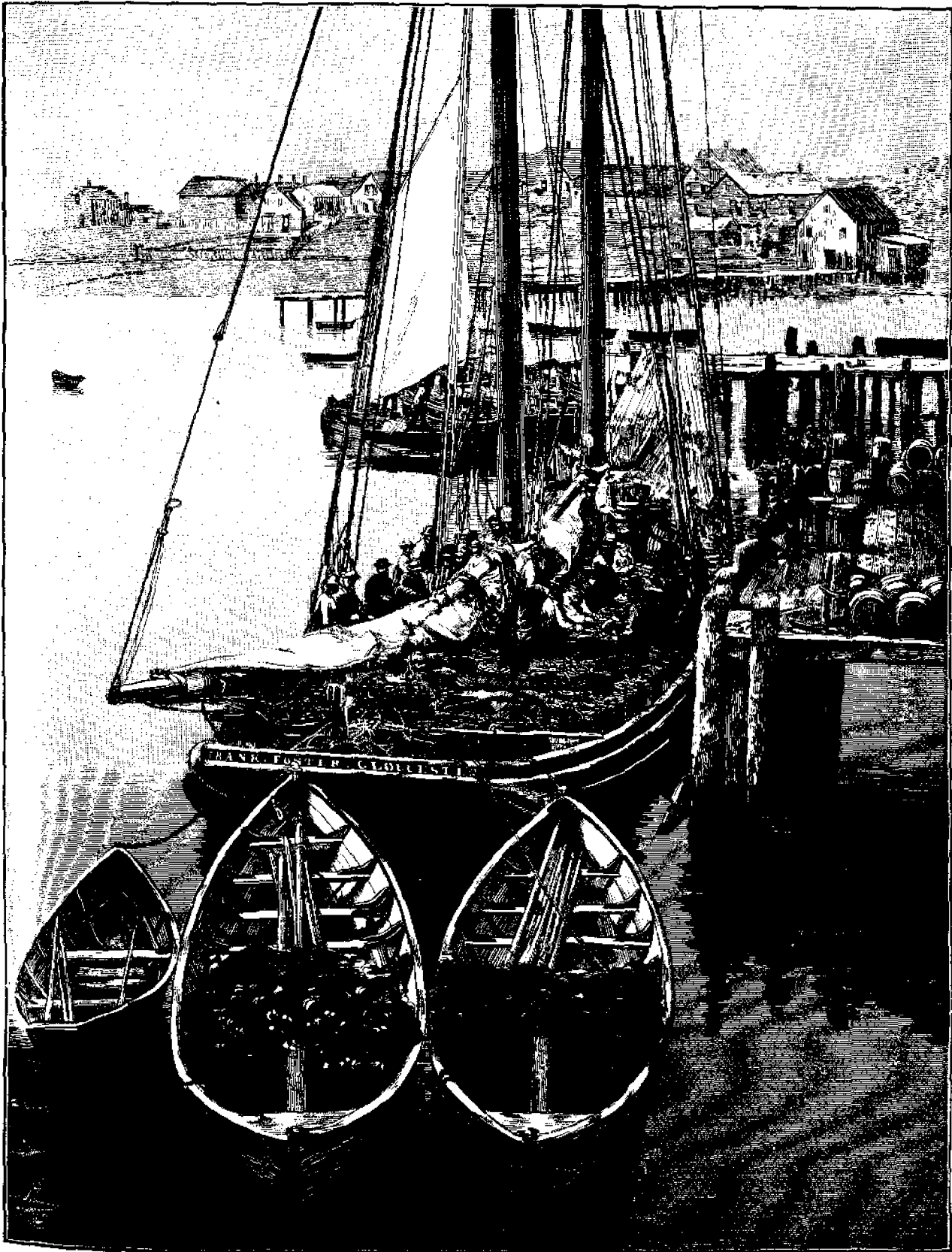

**THE MACKEREL PURSE-SEINE FISHERY.**

Schooner just arrived from cruise; crew dressing and salting the fish. (Sect. v, vol. i, p. 267.)

From a photograph by T. W. Sullie.

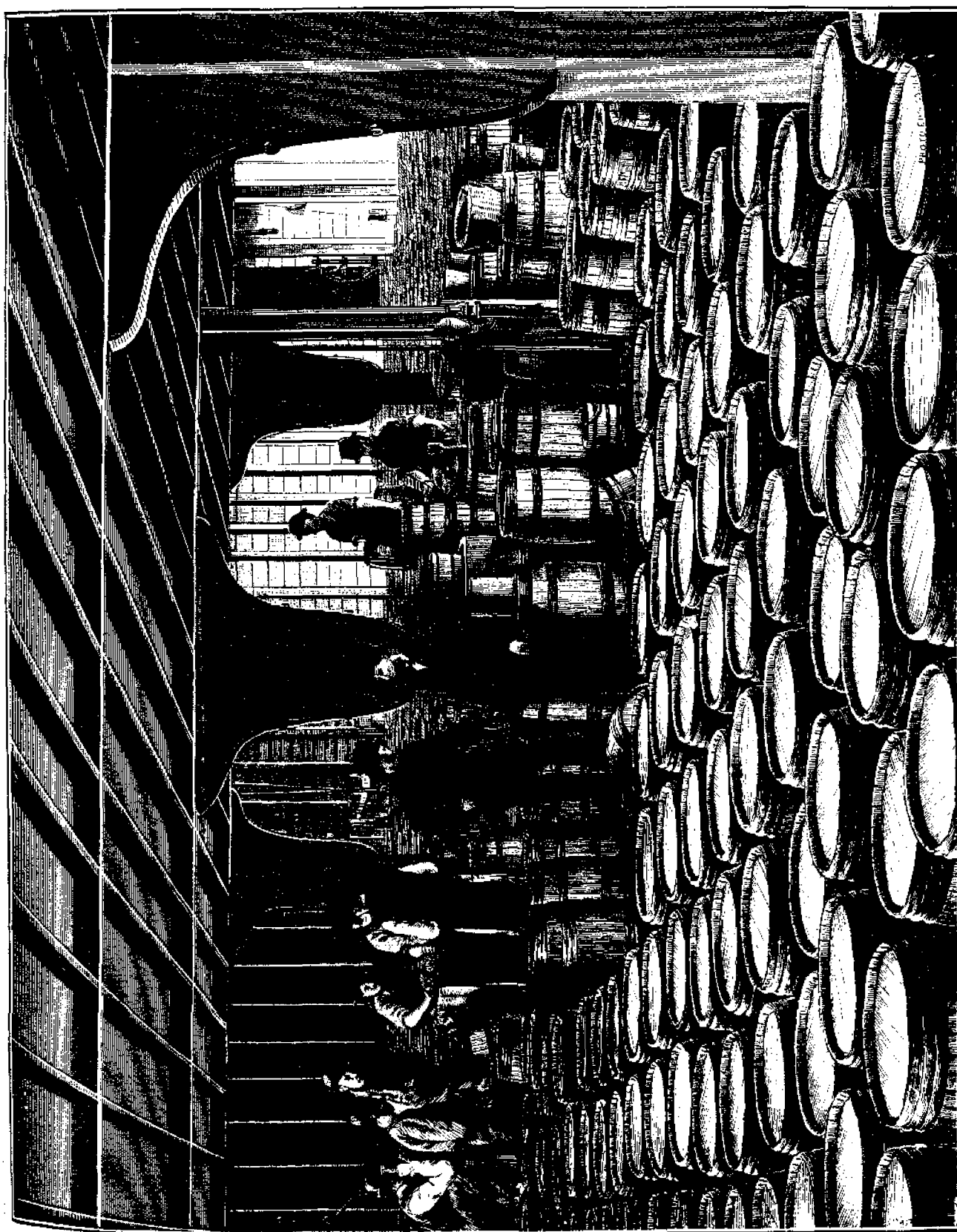

**THE MACKEREL FISHERY.**

Culling and packing mackerel at Portland, Me. (Sect. V, vol. 4, p. 267.)  
From a photograph by T. W. Smilie

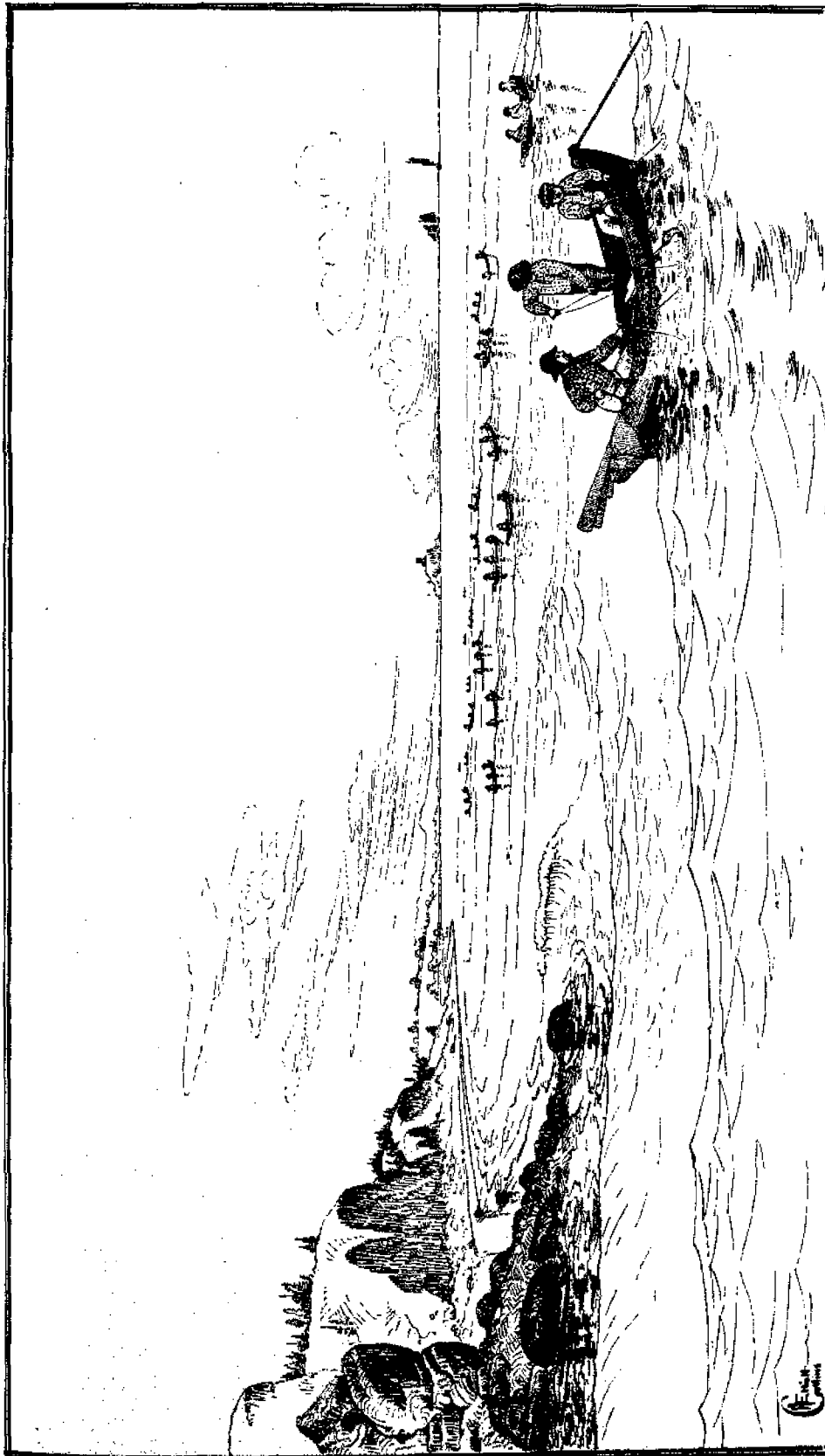

**THE MACKEREL HOOK FISHERY.**

Fishing for mackerel in boats. (Sect. v, vol. i, p. 275.)

Drawing by H. W. Elliott and Capt. J. W. Collins.

© 1914  
G. P. Putnam's Sons



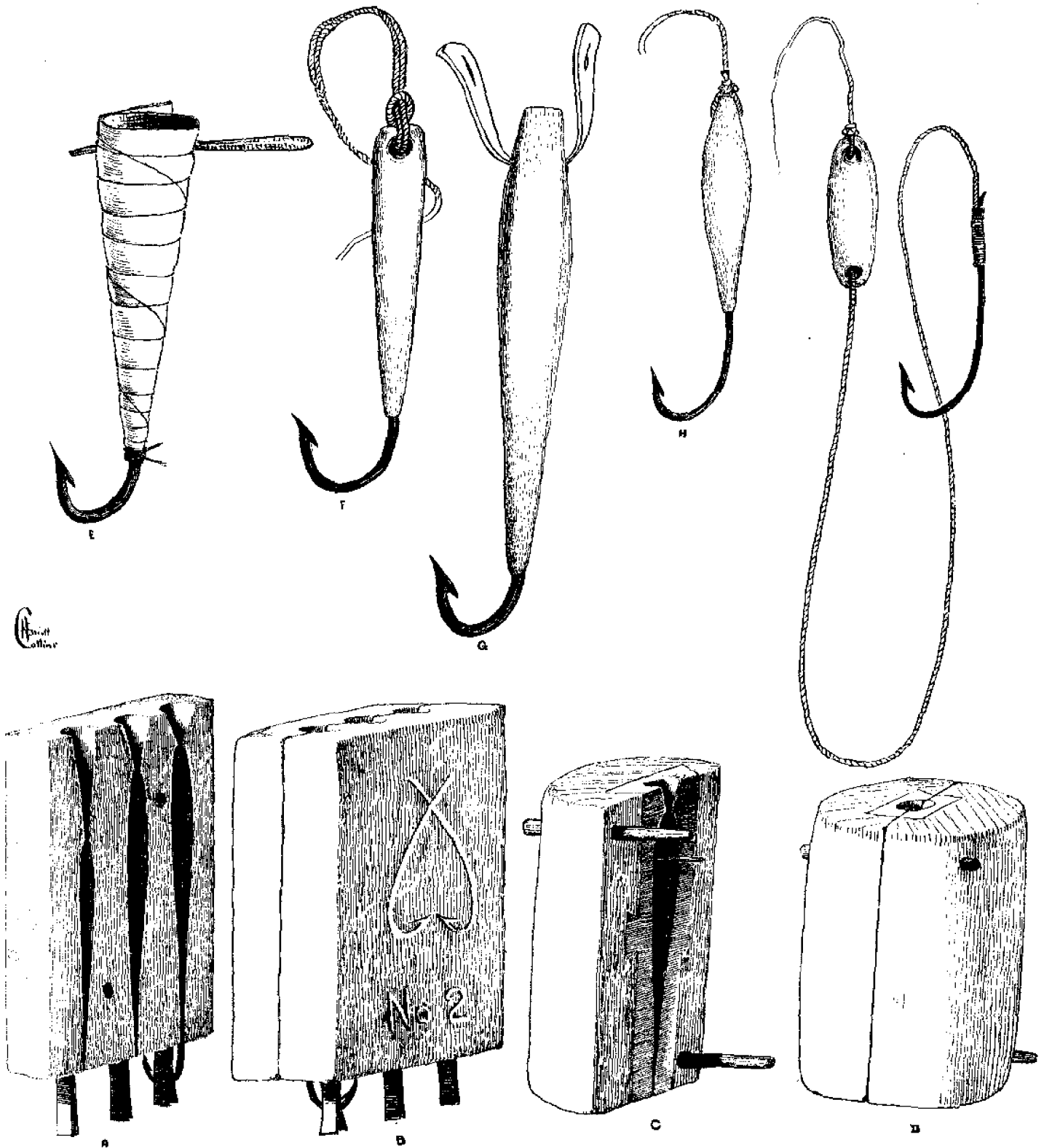

THE MACKEREL HOOK FISHERY.

jigs and jig-molds: A, one side of soapstone jig-mold, showing method of setting hook; B, soapstone jig-mold, closed; C, one side of lead jig-mold made by fishermen; D, lead jig-mold, closed; E, old-style paper jig-mold; F and G, types of jigs, natural size, cast in paper molds; H, type of jig, of medium size, cast in soapstone molds. I, mackerel bobber. (Sect. v, vol. i, p. 278.)

Drawings by H. W. Elliott and Capt. J. W. Collins.

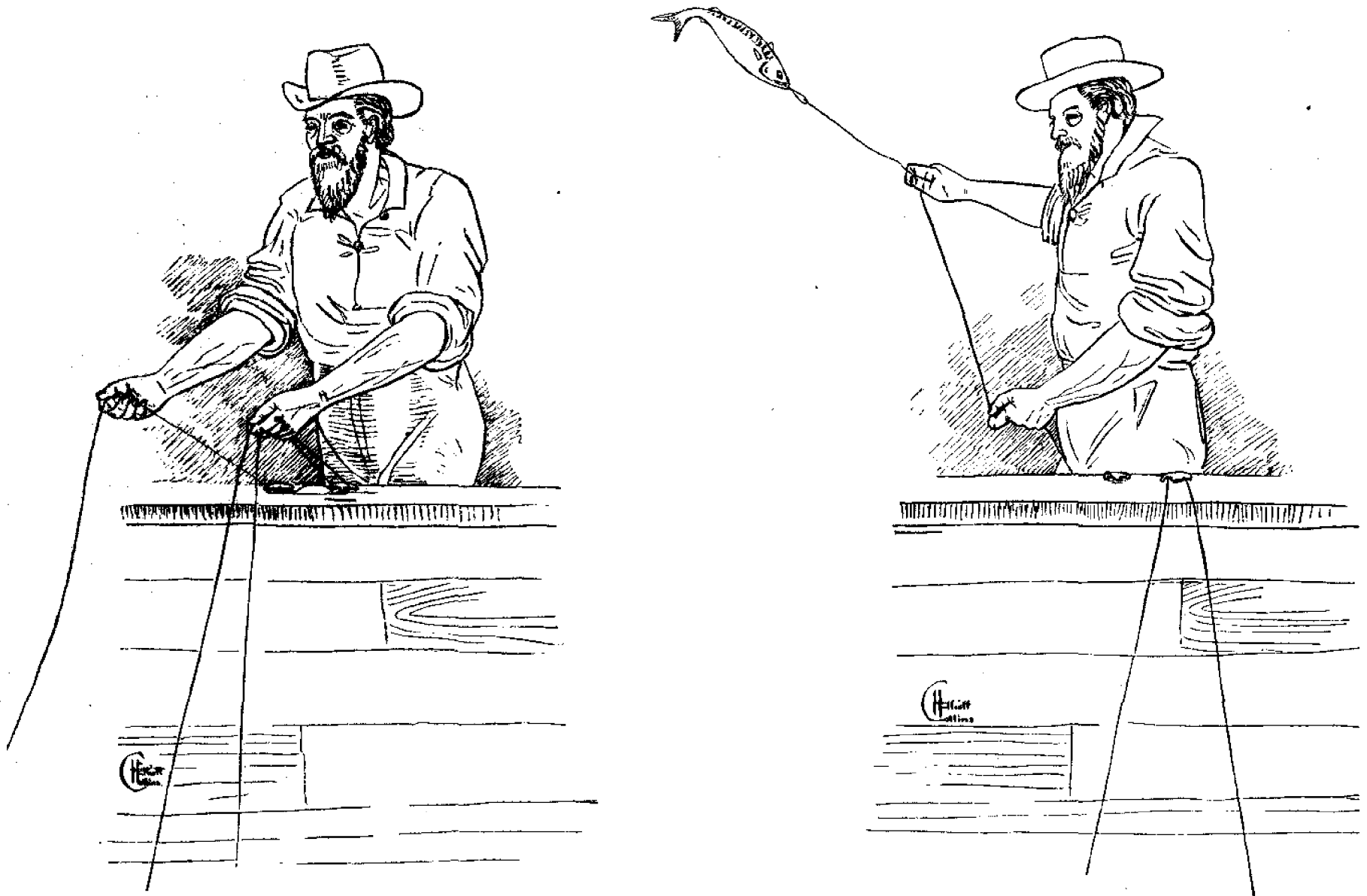

**THE MACKEREL HOOK FISHERY.**

Jigging mackerel over the vessel's rail. (Sect. v, vol. i, p. 284.)

Drawings by H. W. Elliott and Capt. J. W. Collins.

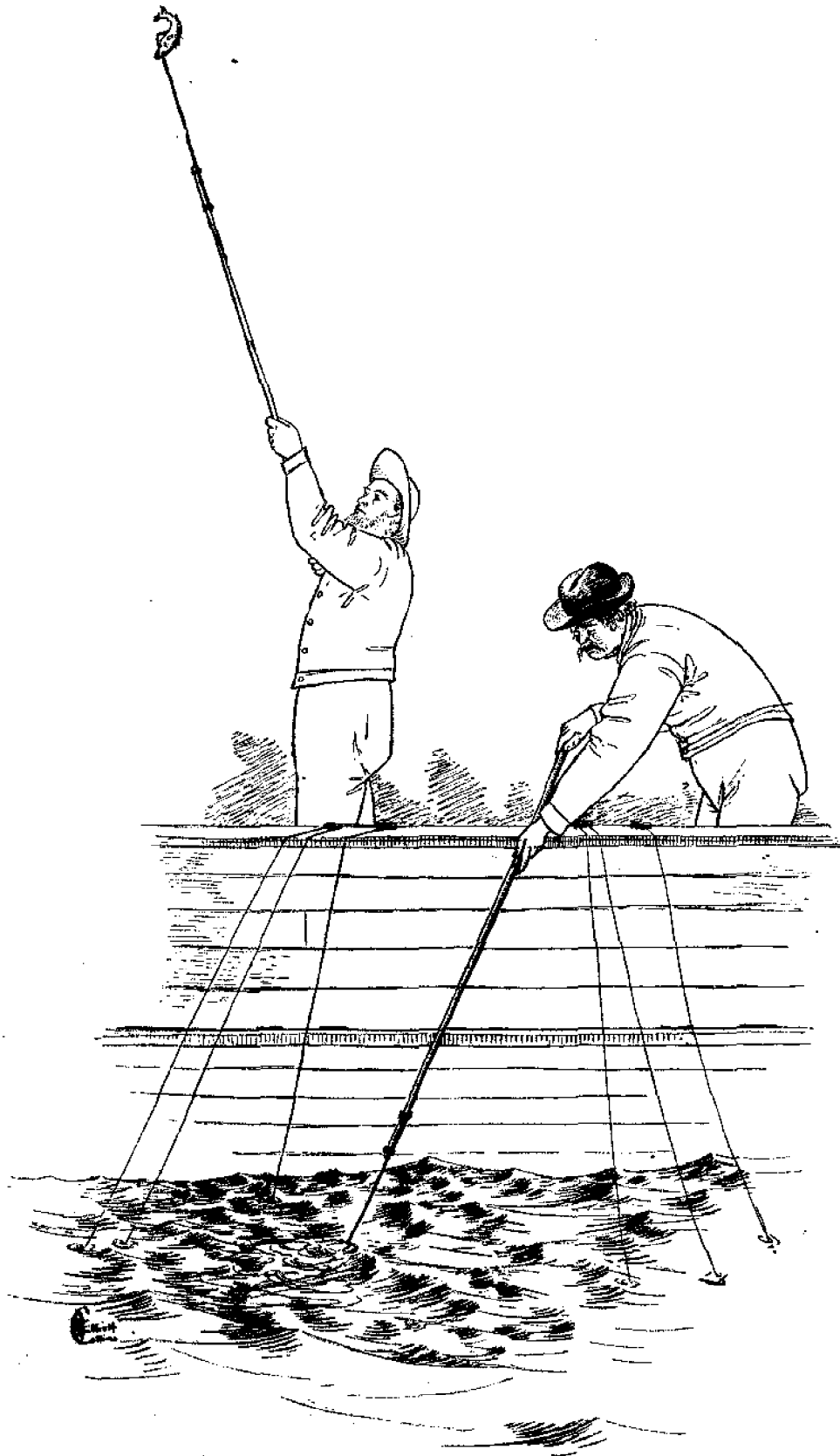

**THE MACKEREL HOOK FISHERY.**

Gaffing mackerel over the vessel's rail. (Sect. v, vol. i, p. 279.)

Drawing by H. W. Elliott and Capt. J. W. Collins.



Fig. 1.

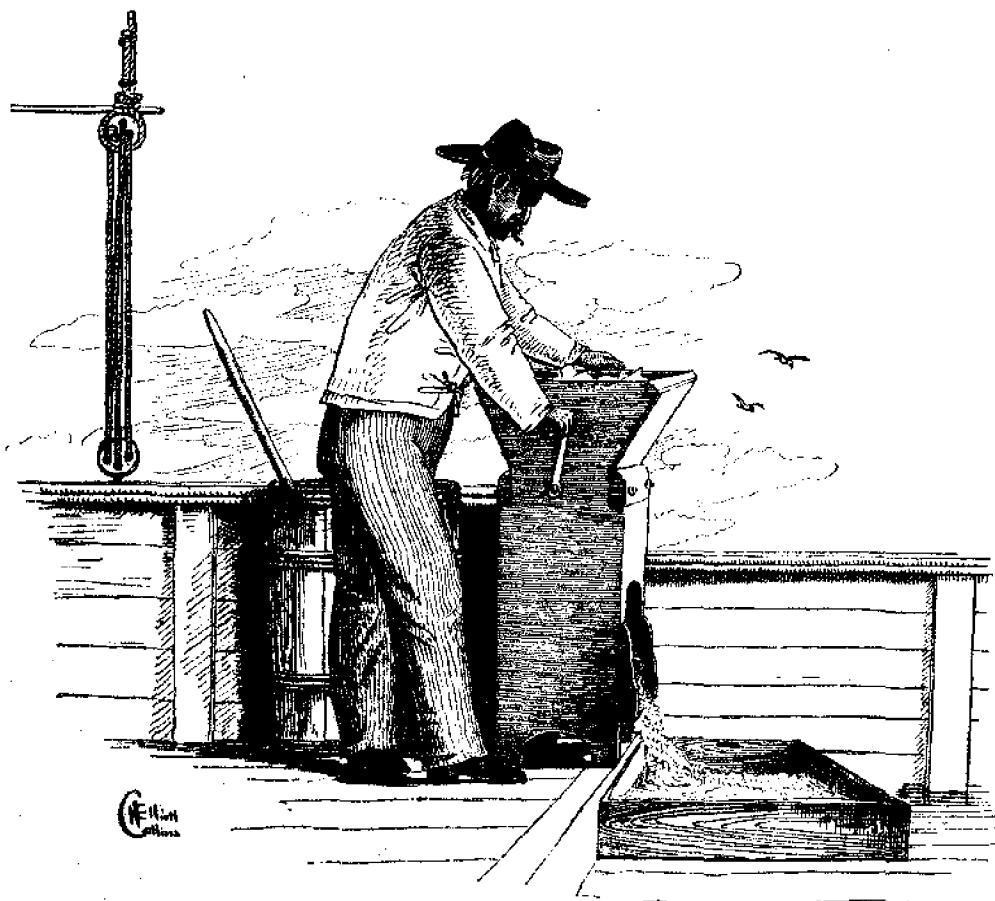

Fig. 2.

### THE MACKEREL HOOK FISHERY.

FIG. 1. The old method of chopping bait. (Sect. v, vol. i, pp. 279-283.)

FIG. 2. The modern bait-mill. (Sect. v, vol. i, pp. 279-283.)

Drawings by H. W. Elliott and Capt. J. W. Collins.

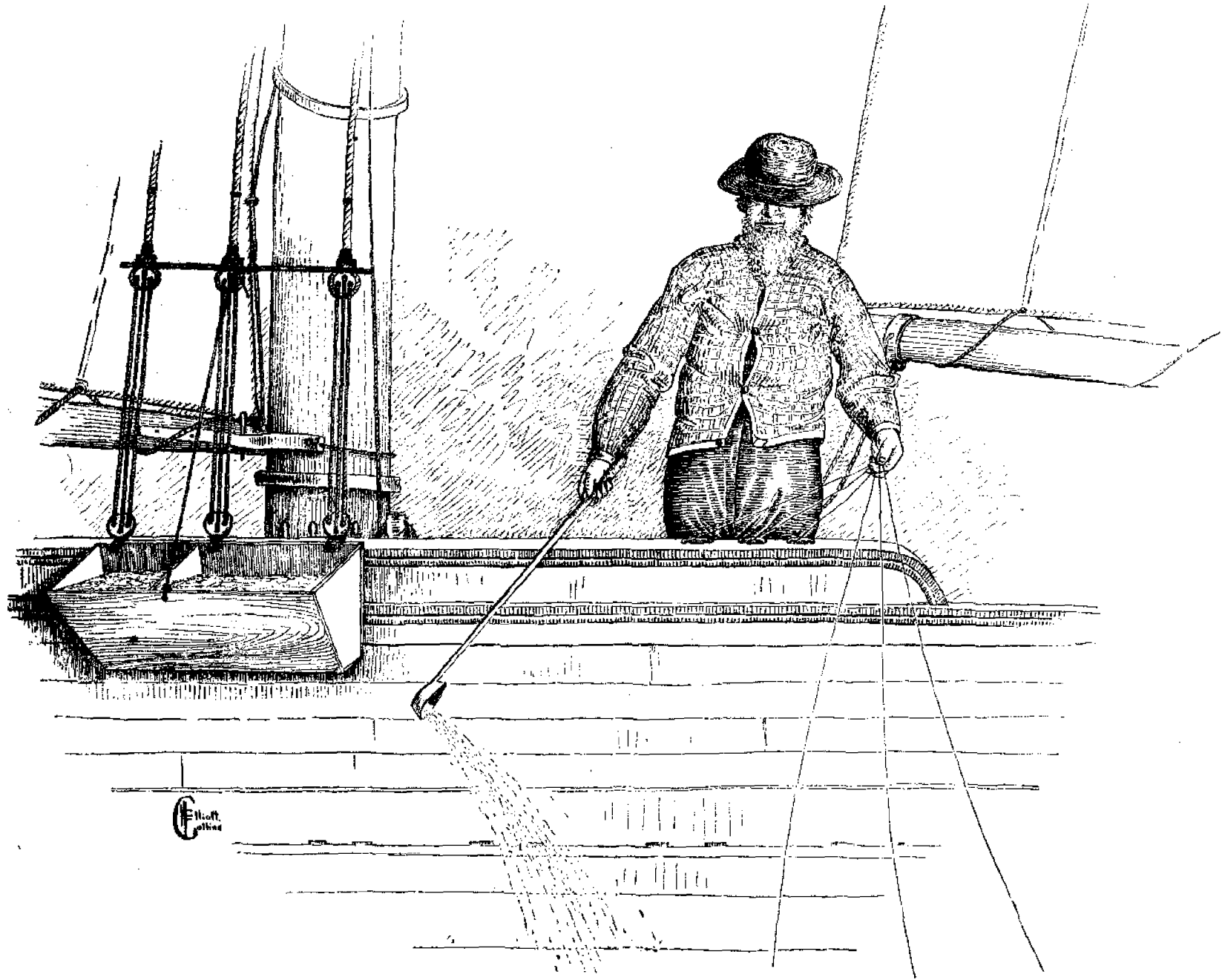

**THE MACKEREL HOOK FISHERY.**

Throwing bait to toll mackerel alongside the vessel. (Sect. v, vol. i, p. 294.)

Drawing by H. W. Elliott and Capt. J. W. Collins.

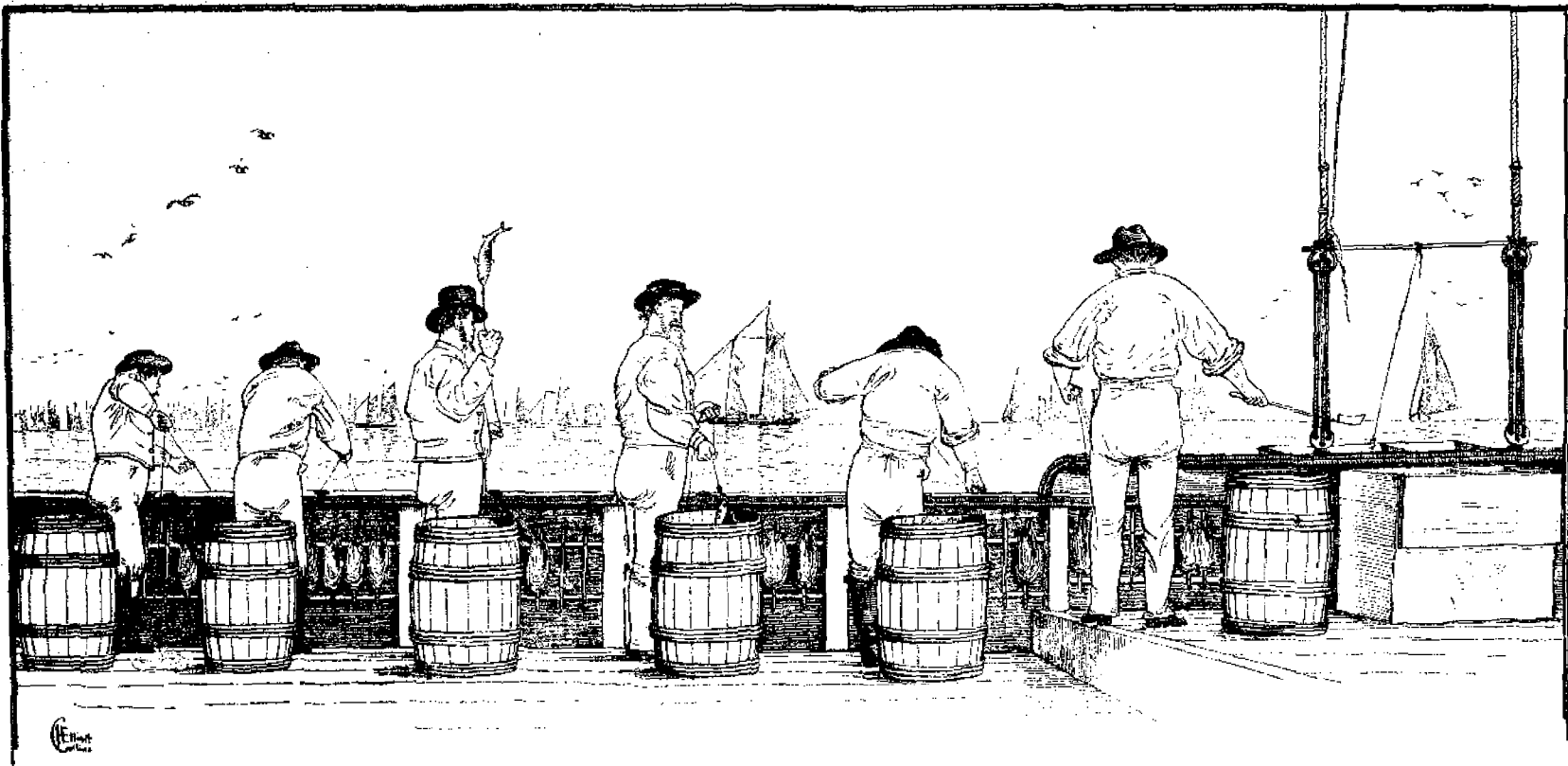

**THE MACKEREL HOOK FISHERY.**

Deck scene on mackerel hand-line schooner; jigging mackerel, slatting in the barrel, throwing toll bait. (Sect. v, vol. i, p. 284.)

Drawing by H. W. Elliott and Capt. J. W. Collins.



Fig. 1.—Splitting, cleaning, and washing.

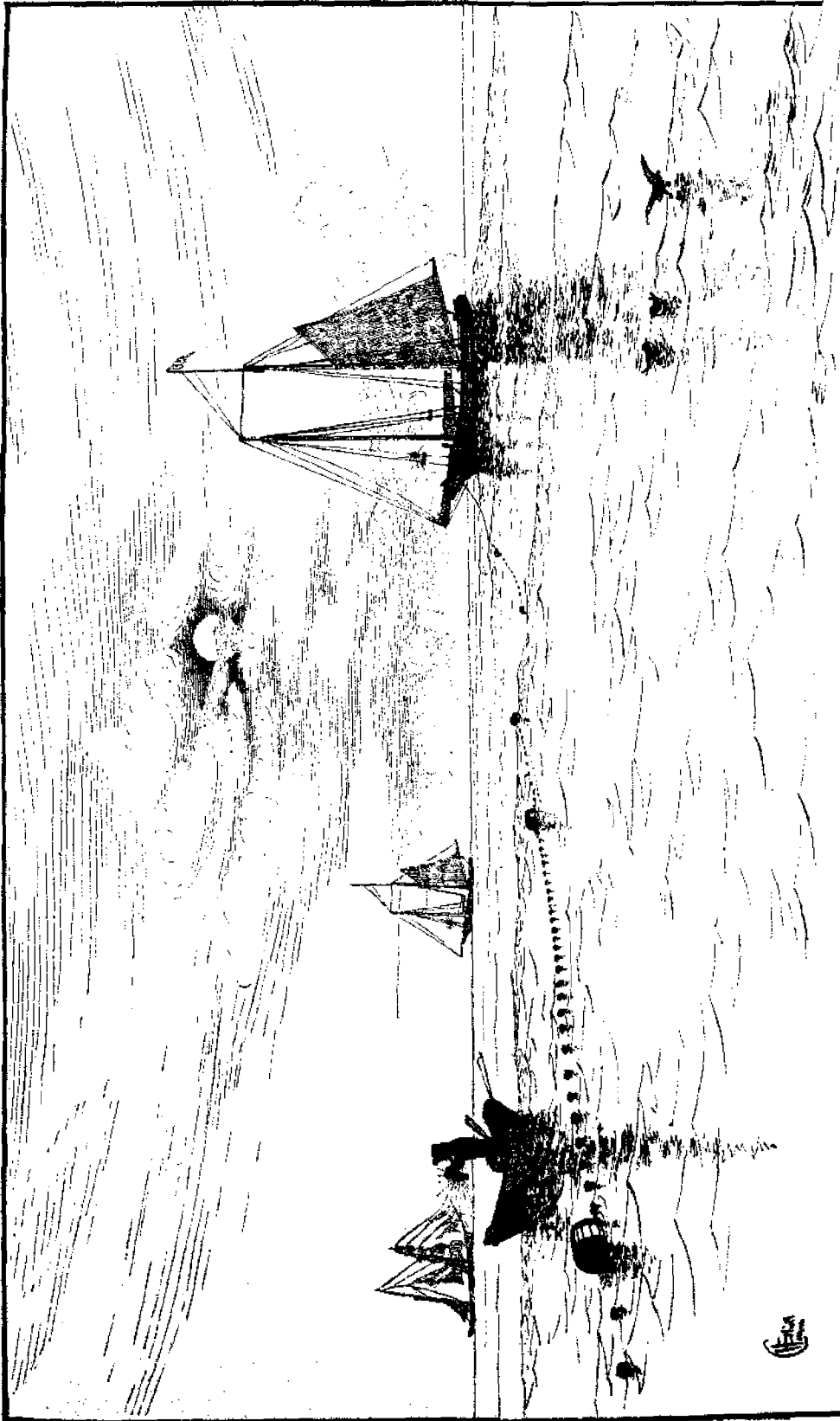

Fig. 2.—Pitching, salting, and plowing.

**THE MACKEREL HOOK FISHERY.**

Mackerel packing on shipboard. (Sect. v, vol. i, p. 287.)

Drawings by H. W. Elliott and Capt. J. W. Collins.



**THE MACKEREL GILL-NET FISHERY.**

Drag-nets set at night off coast of Maine. (Sect. v, vol. 1, p. 234.)

Drawing by H. W. Elliott and Capt. J. W. Collins.



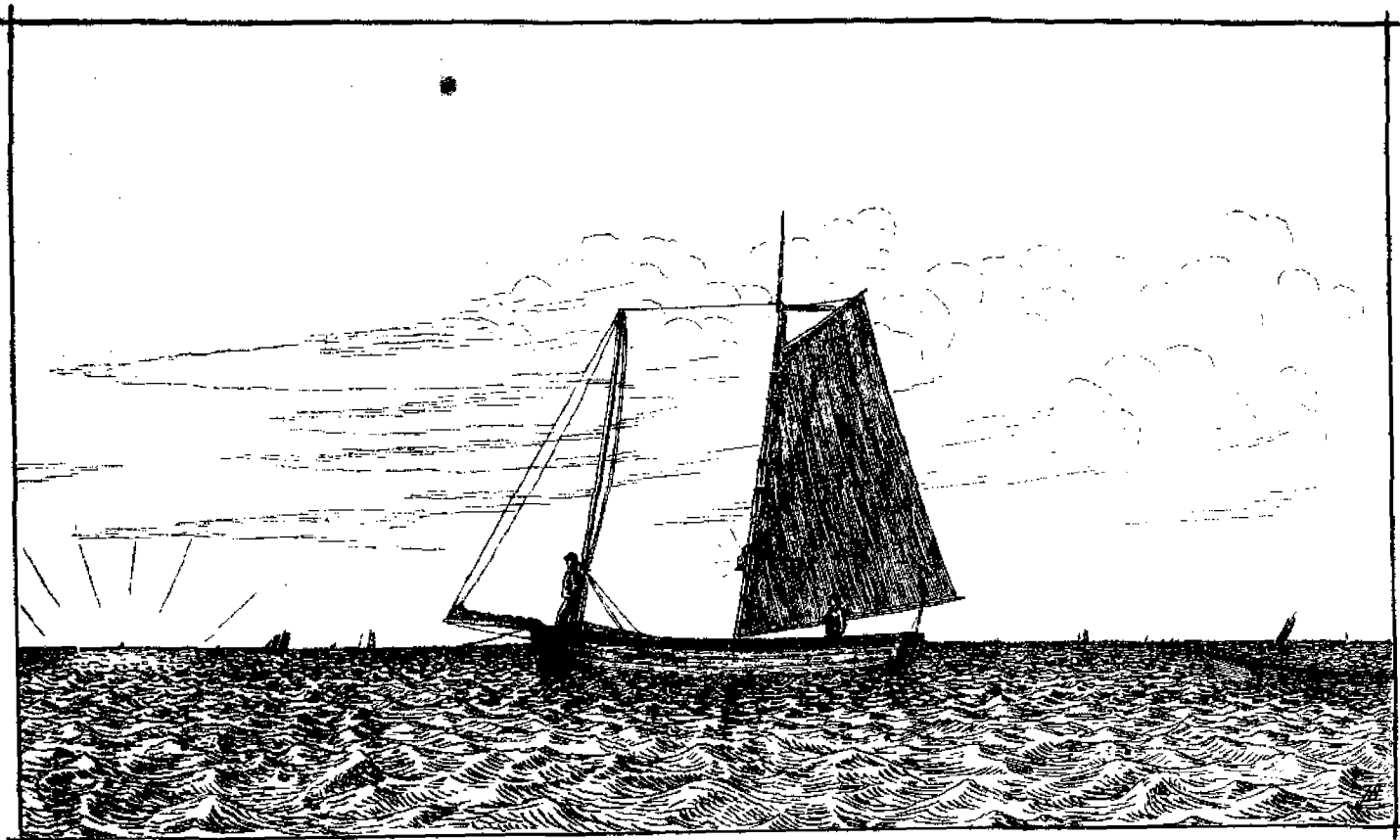

**THE MACKEREL GILL-NET FISHERY.**

Cape Cod mackerel drag-boat "lying to" at night. (Sect. v, vol. i, p. 294.)

Drawing by Capt. J. W. Collins.



**THE MACKEREL GILL-NET FISHERY.**

Dory fisherman picking mackerel gill-nets. (Sect. v, vol. i, p. 294.)

From a photograph by T. W. Smilie.

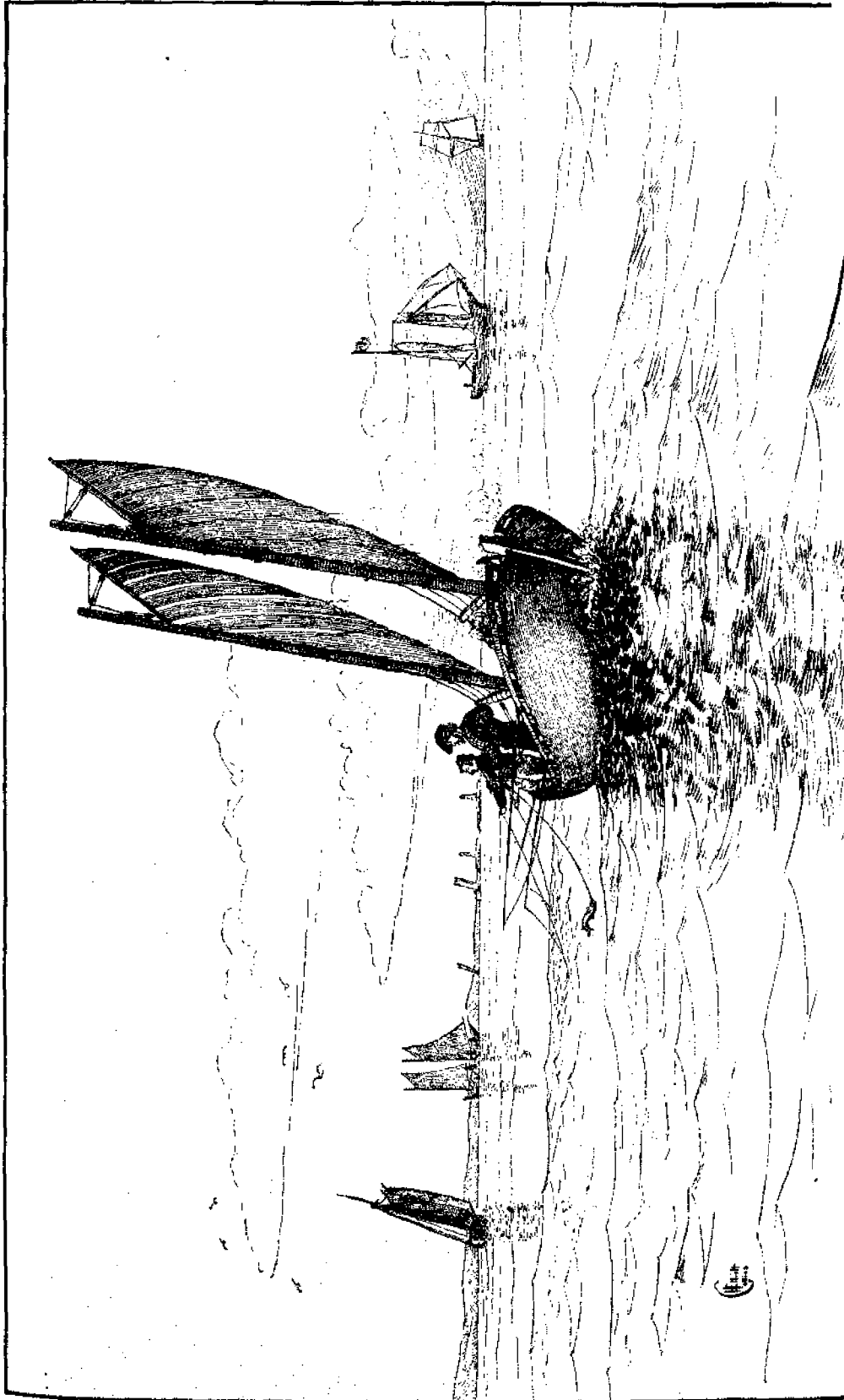

**THE MACKEREL FISHERY—EARLY METHODS.**

Old style Chetaccoe hont drailing for mackerel. (Sect. v, vol. i, p. 299.)

Drawing by H. W. Elliott and Capt. J. W. Collins.

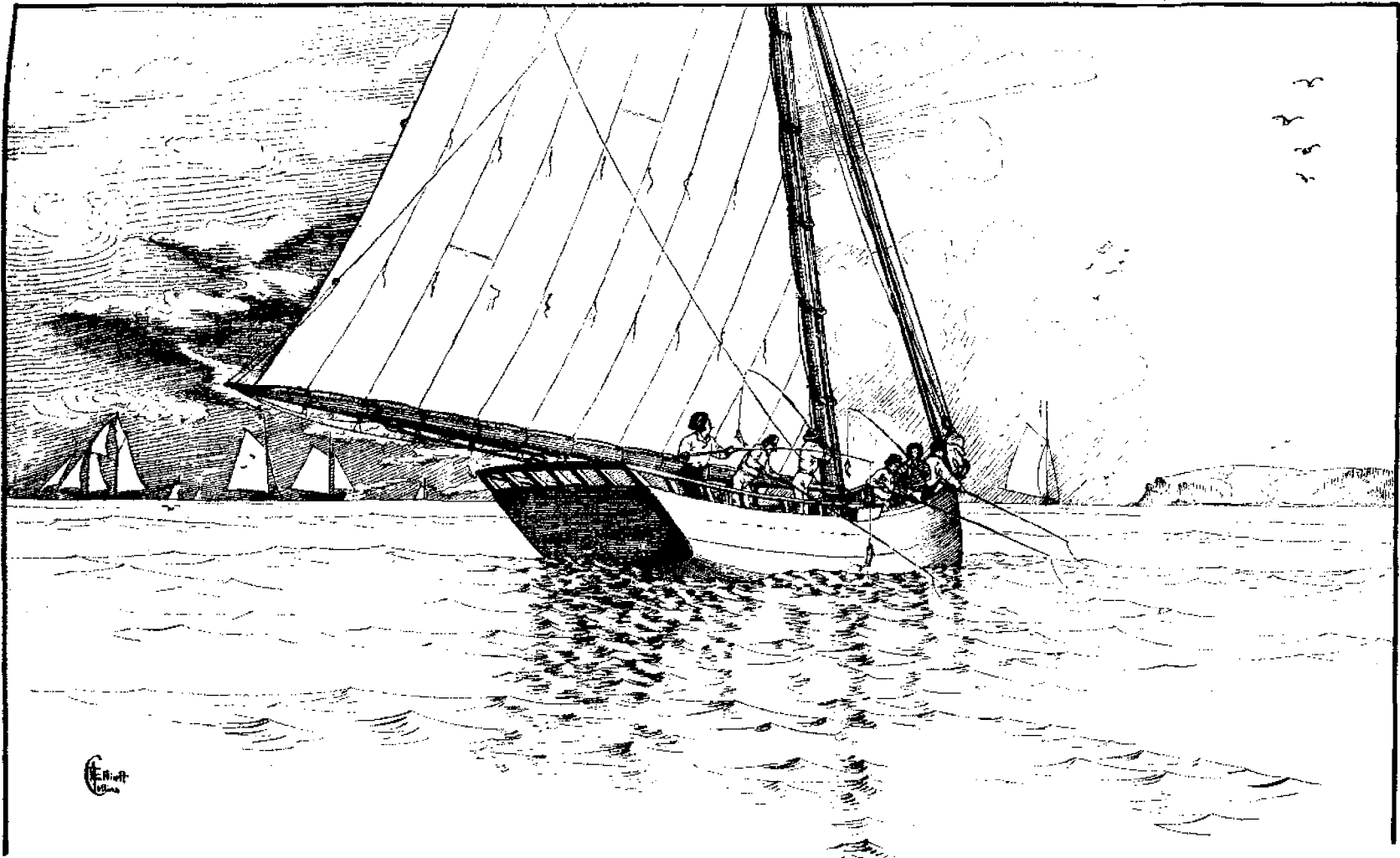

**THE MACKEREL FISHERY—EARLY METHODS.**

Angling with poles for mackerel from old style Noank, Conn., sloop. (Sect. v, vol. i, p. 299.)

Drawing by H. W. Elliott and Capt. J. W. Collins.

Diagram showing the Catch of Mackerel by Citizens of Massachusetts between the years 1804 and 1891 inclusive.

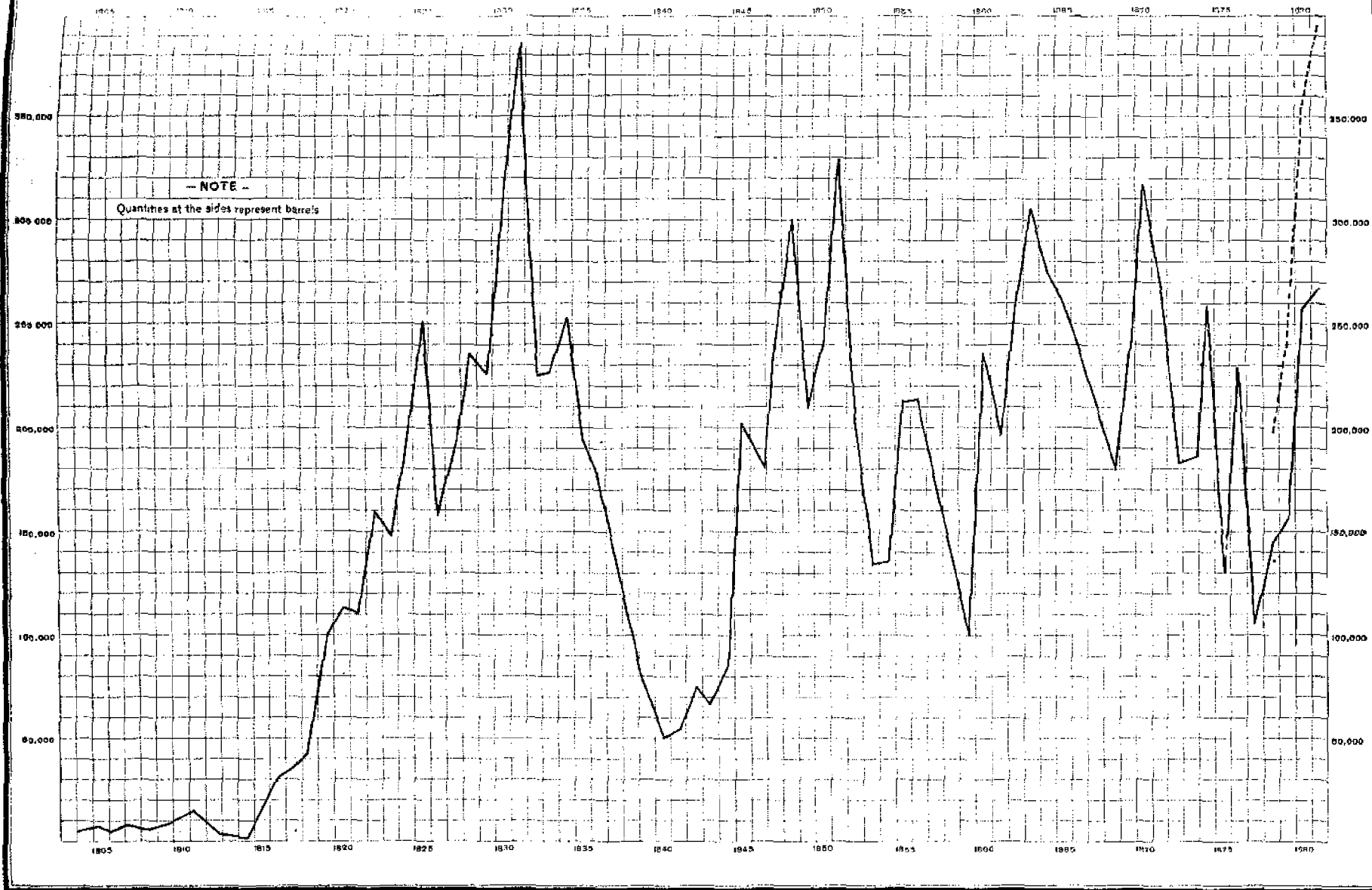

THE MACKEREL FISHERY.

Statistics of inspection of salt mackerel; the total product marketed fresh and salt, 1878 to 1891, shown by the broken line. (Sect. v, vol. i, p. 312.)

From Report U. S. Fish Commission, Part IX, 1881.

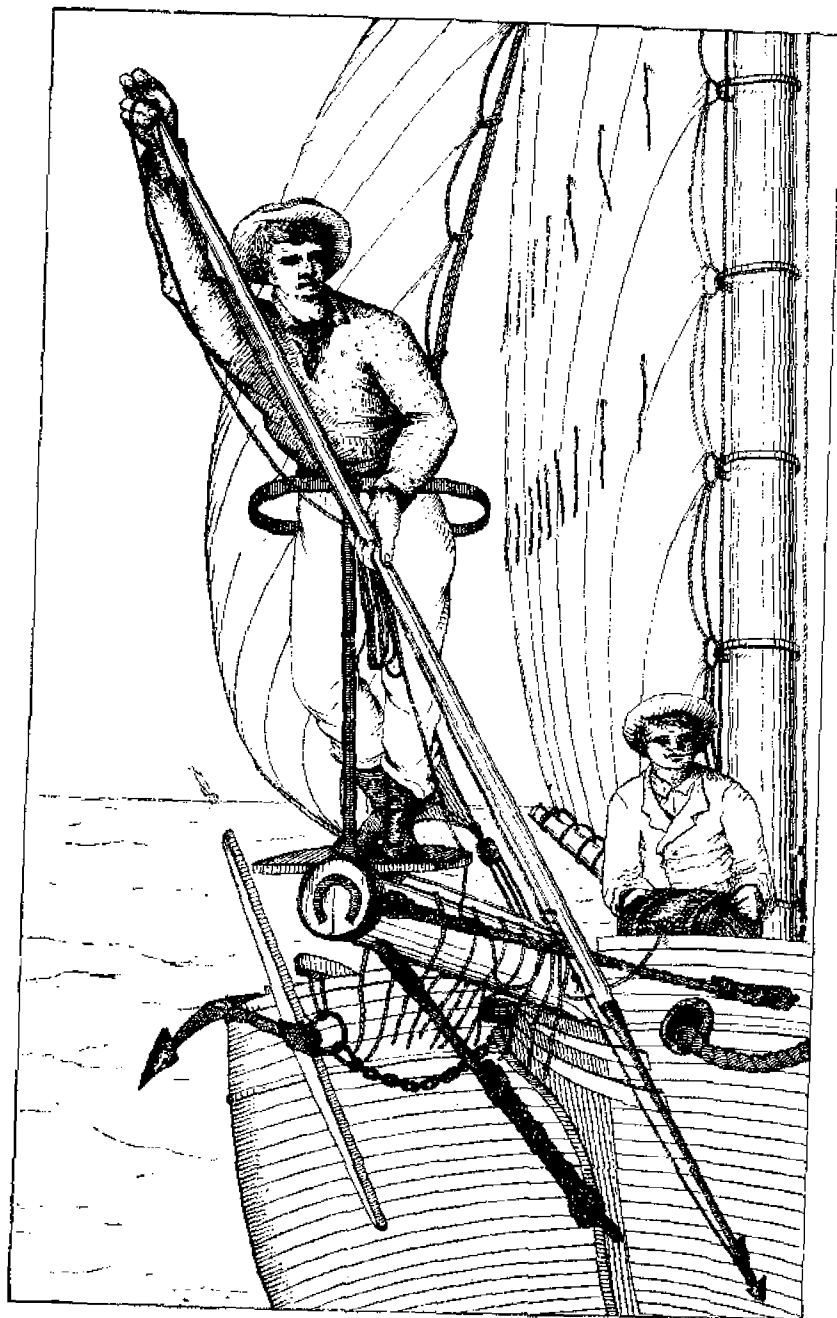

**THE SWORDFISH FISHERY.**

Swordfisherman in position for action. (Sect. v, vol. i, p. 318.)

From Report U. S. Fish Commission, Part VIII, 1886.

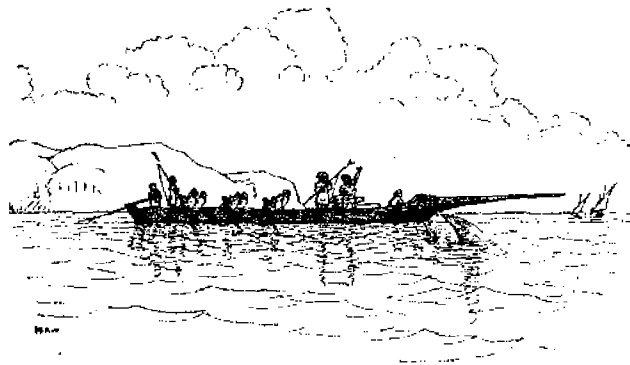
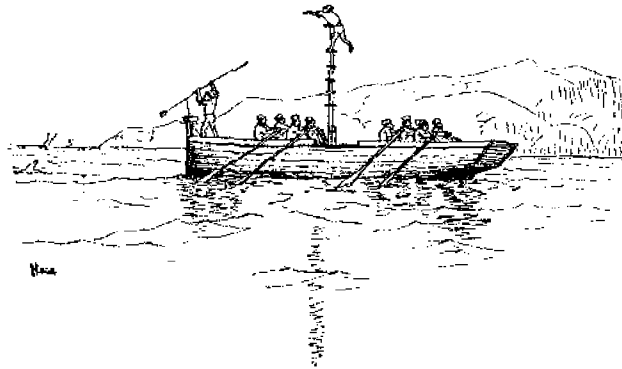

**THE SWORDFISH FISHERY.**

Methods of fishing in the Mediterranean Sea.

Drawings by H. W. Elliott in Report U. S. Fish Commission, Part VIII, 1880.

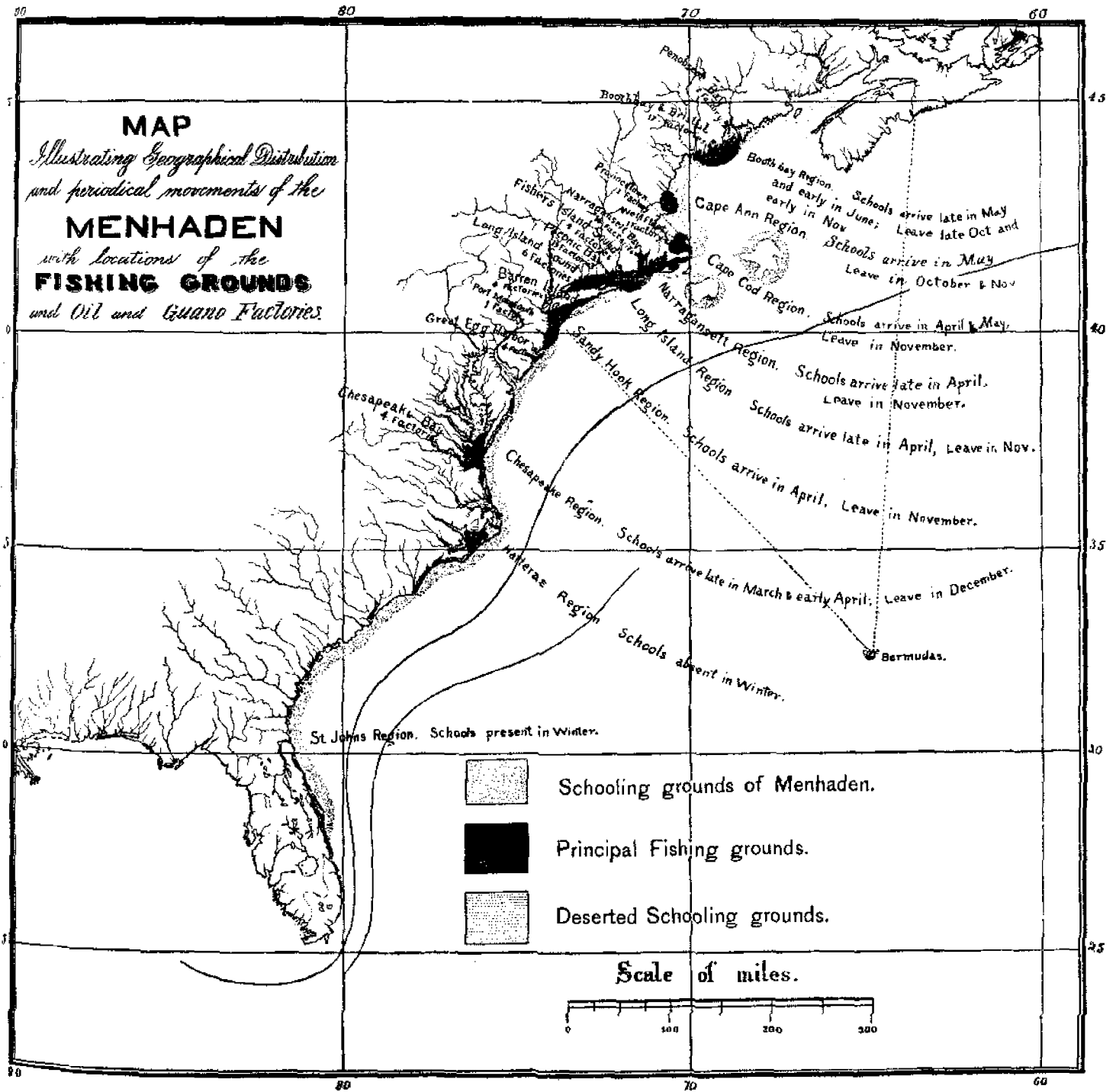

**THE MENHADEN FISHERY.**

The fishing grounds and oil factories in 1878. (Sect. v, vol. i, pp. 331, 343.)  
 (No factories now in Maine; large number in Chesapeake Bay.)

From Report U. S. Fish Commission, Part VI, 1878.



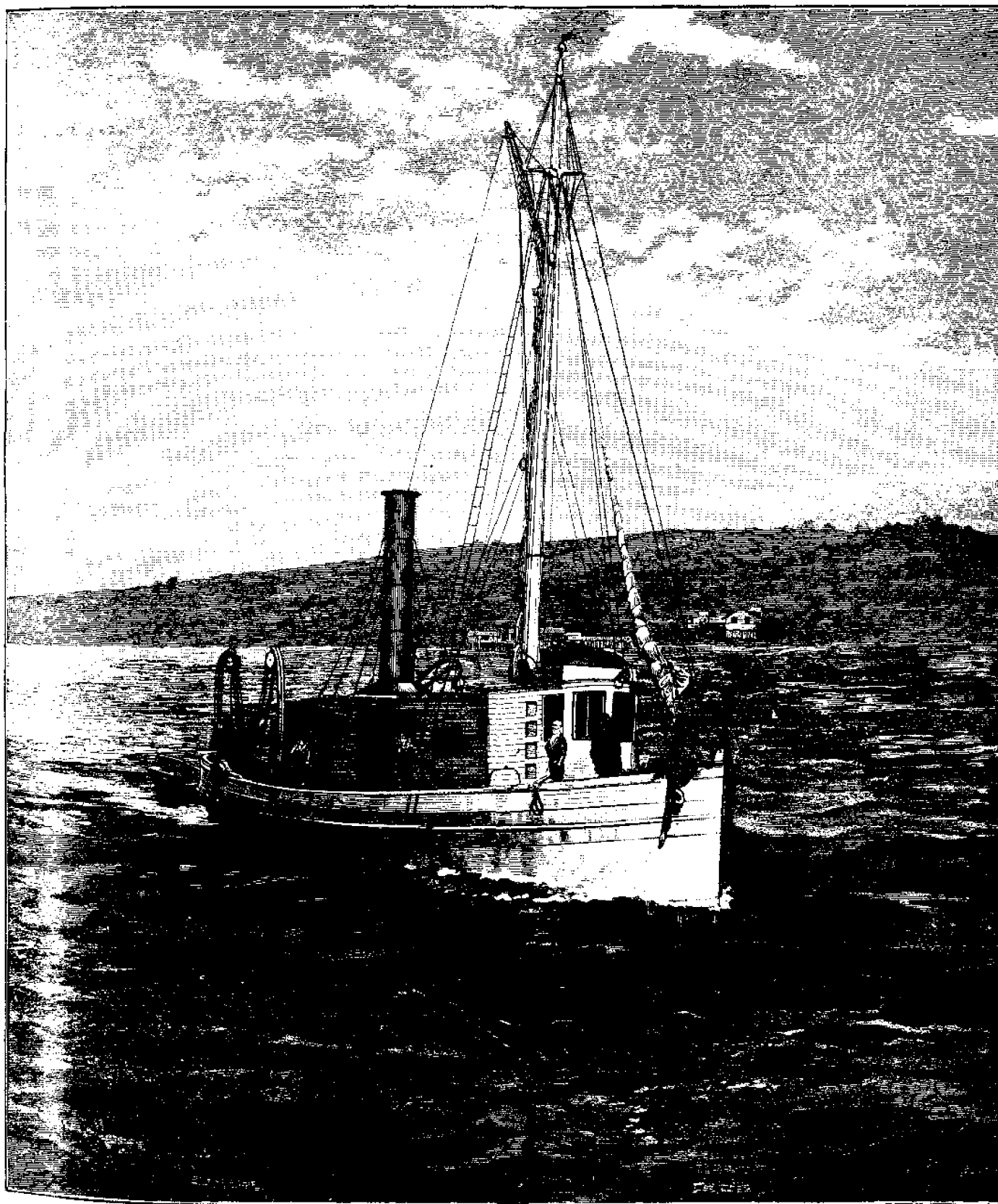

**THE MENHADEN FISHERY.**

Menhaden steamer Joseph Church approaching oil and guano factory at Tiverton, R. I. (Sect. v, vol. i, p. 34.)

From a photograph by T. W. Smith.

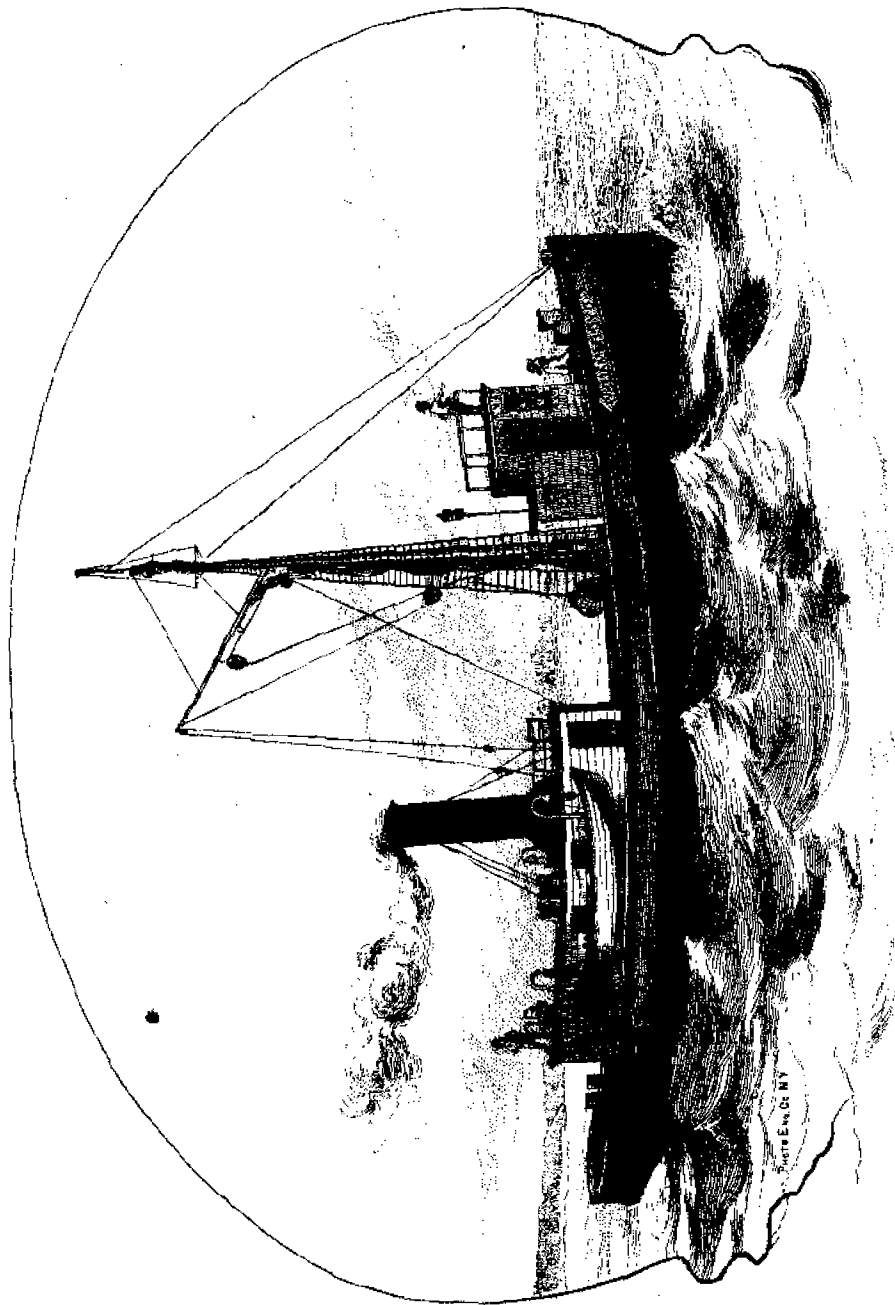

**THE MENHADEN FISHERY.**

Menhaden steamer cruising for fish. (Sect. v, vol. i, p. 334.)

Drawing by Capt. B. F. Conkln.

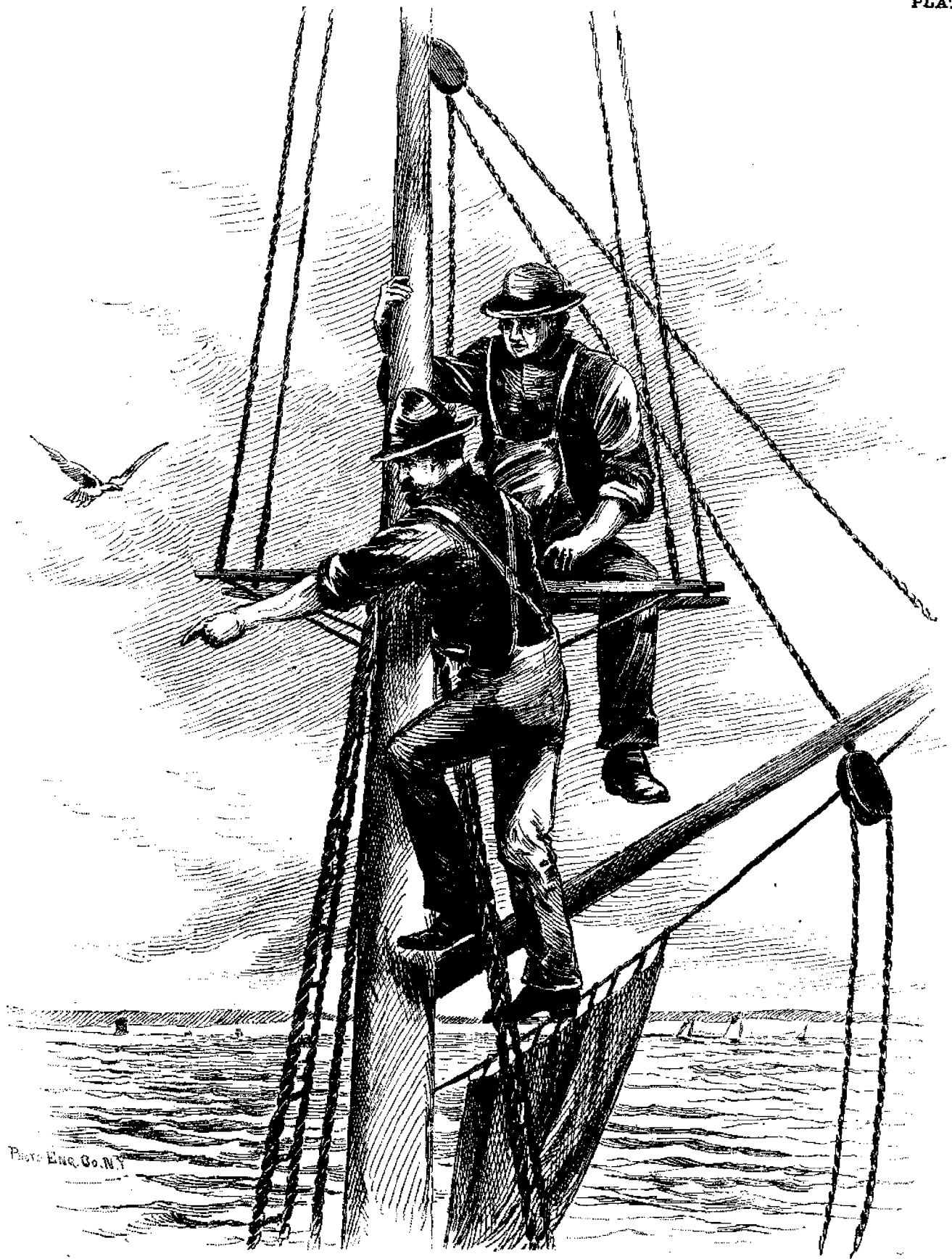
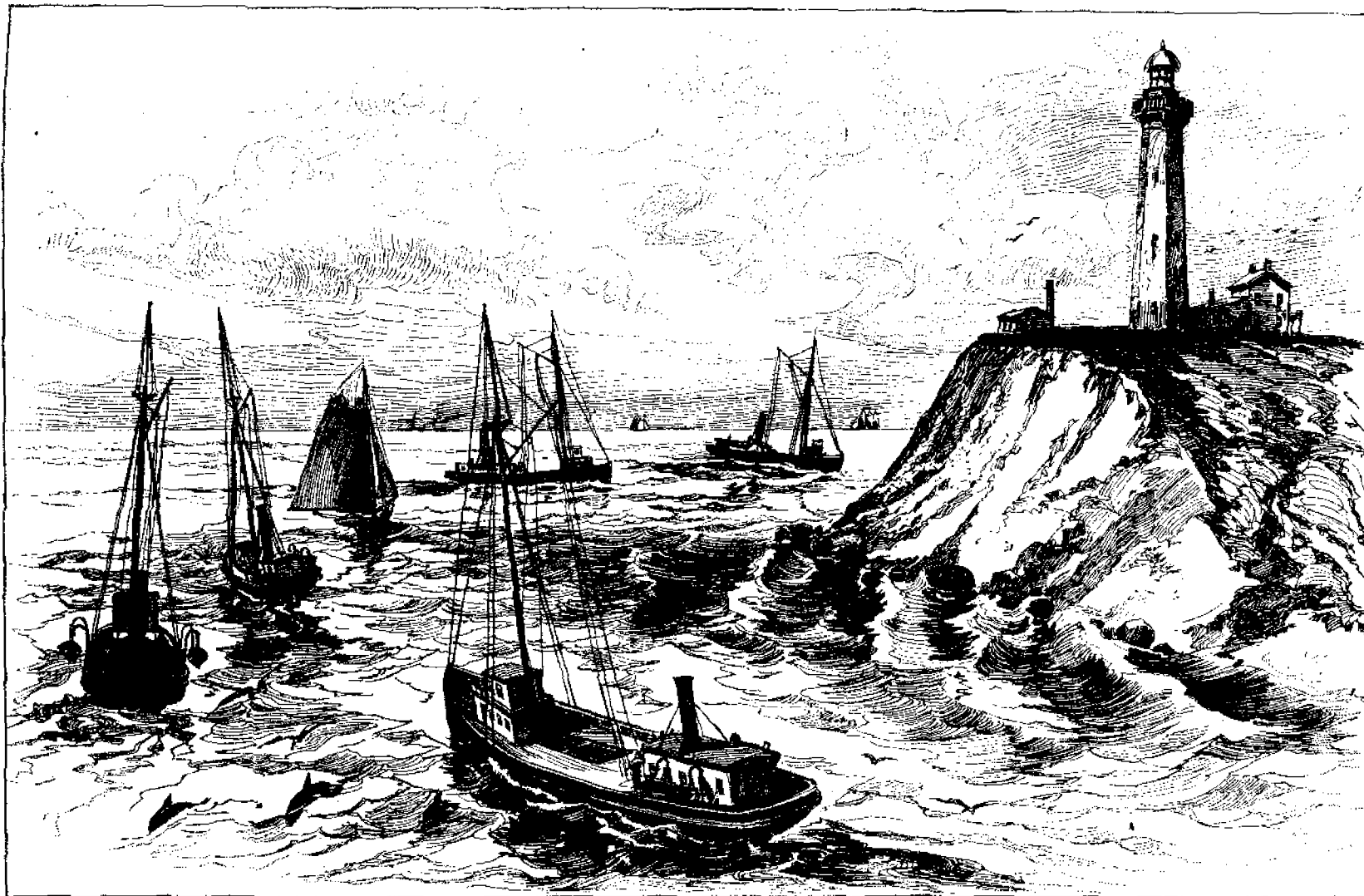

Photo Eng. Co. N.Y.

**THE MENHADEN FISHERY.**

Lookouts at masthead of menhaden steamer watching for schools. (Sect. v, vol. i, p. 333.)

From sketch by J. S. Ryder.



**THE MENHADEN FISHERY.**

Fleet of menhaden steamers en route to fishing grounds on south side of Long Island. (Sect. v, vol. i, p. 338.)

From sketch by Capt. B. F. Conklin.

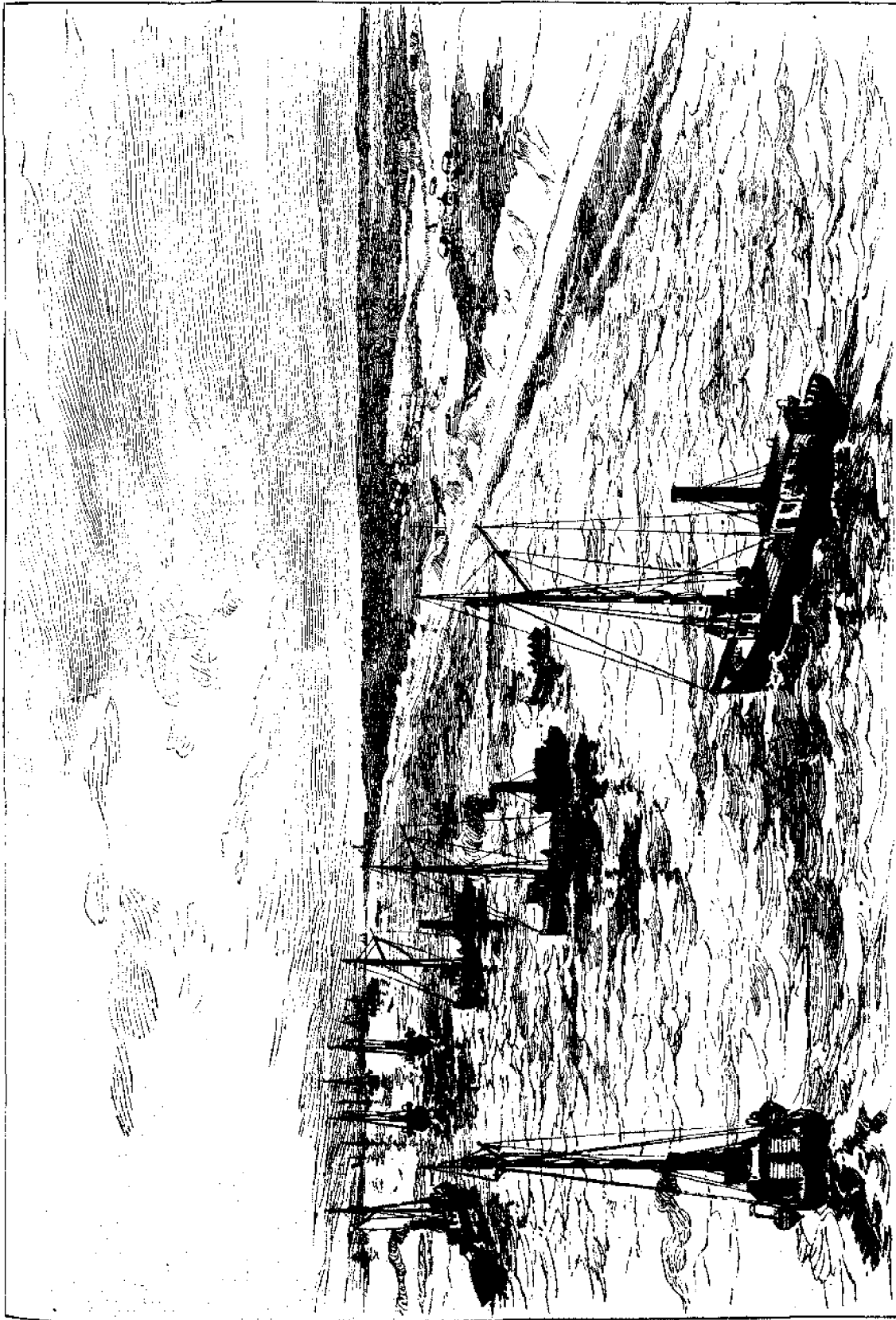

**THE MENHADEN FISHERY.**

Fleet of menhaden steamers on the fishing grounds; seining crews at work. (Sect. V, vol. I, p. 333.)

From sketch by Capt. B. F. Conkling.

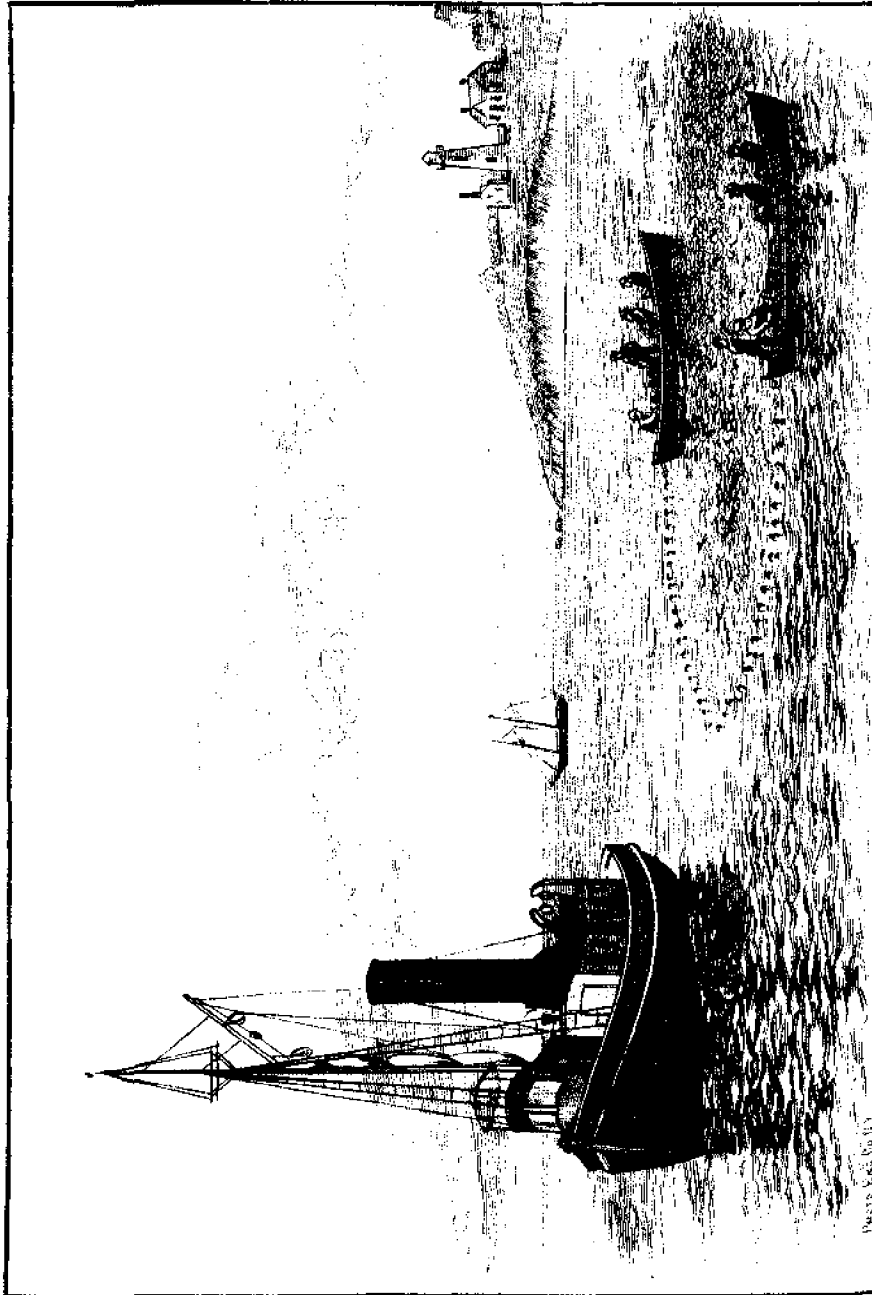

**THE MENHADEN FISHERY.**

Steamer's crew surrounding menhaden with a purse-seine. (Sect. V, vol. 1, pp. 337-338.)

From sketch by Capt. E. F. Conklin.

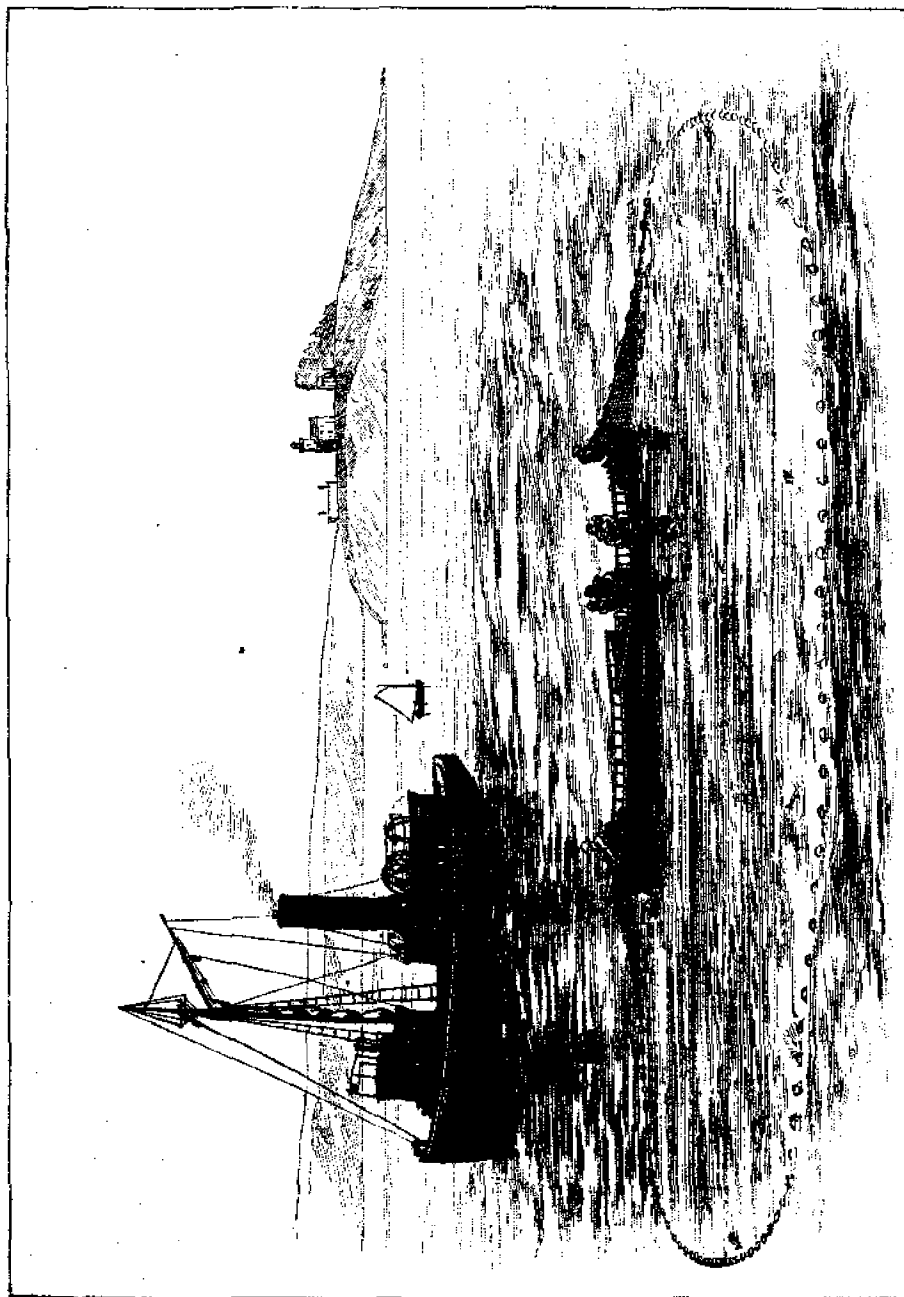

**THE MENHADEN FISHERY.**

Pursing the seine around a school of menhaden. (Sect. v, vol. i, pp. 337-339.)

From sketch by Capt. J. F. Conklin.

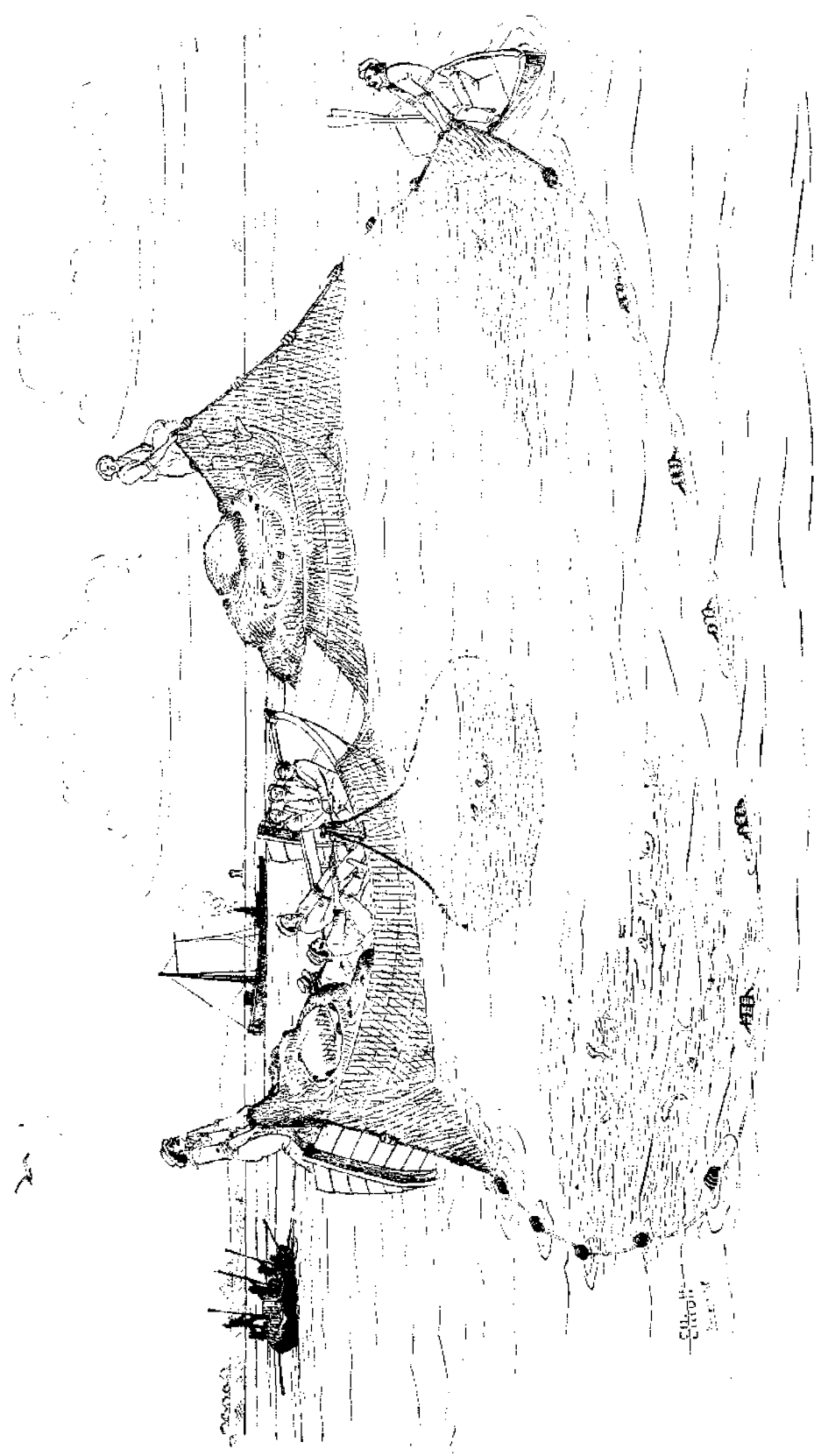

**THE MENHADEN FISHERY.**

Menhaden fishermen at work; pulling of the seine nearly completed. (Sect. v, vol. i, p. 330.)

Drawing by H. W. Elliott.



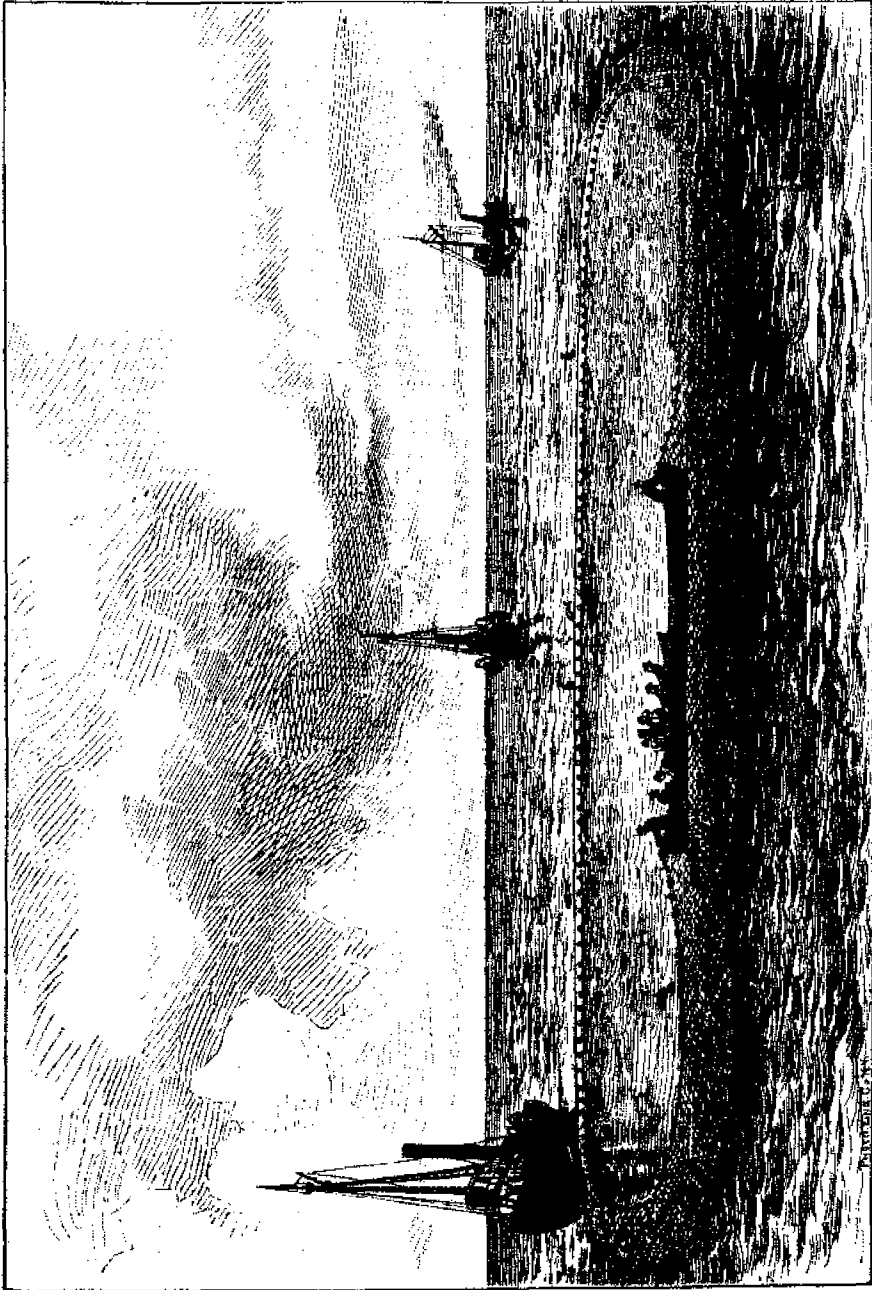

**THE MENHADEN FISHERY.**

School of menhaden surrounded with purse-seine and the fish striking the net. (Sect. v. vol. i, p. 330.)

From sketch by Capt. B. F. Conklin.

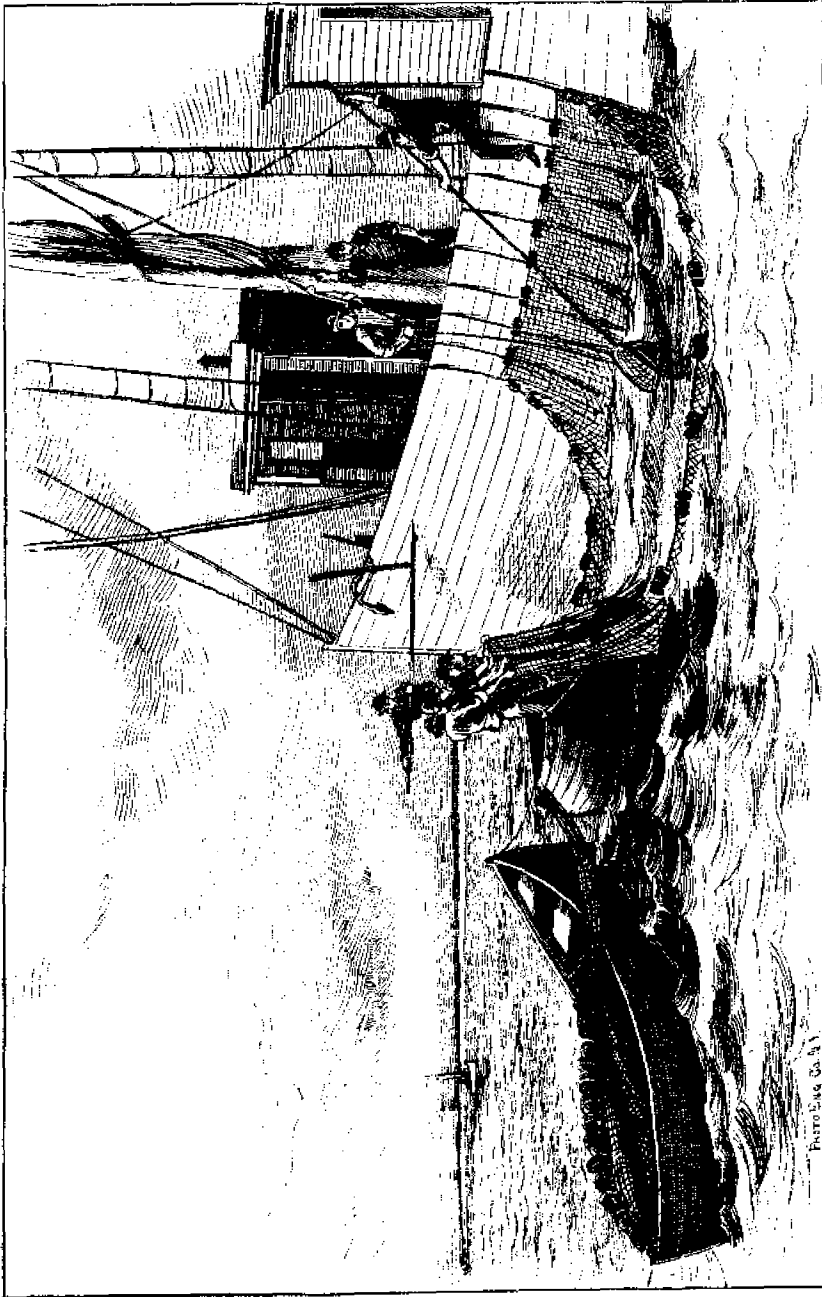

**THE MENHADEN FISHERY.**

Bailing menhaden from purse-seine into steamer's hold. (Sect. v. vol. i, pp. 337, 340.)

From sketch by J. S. Ryder.

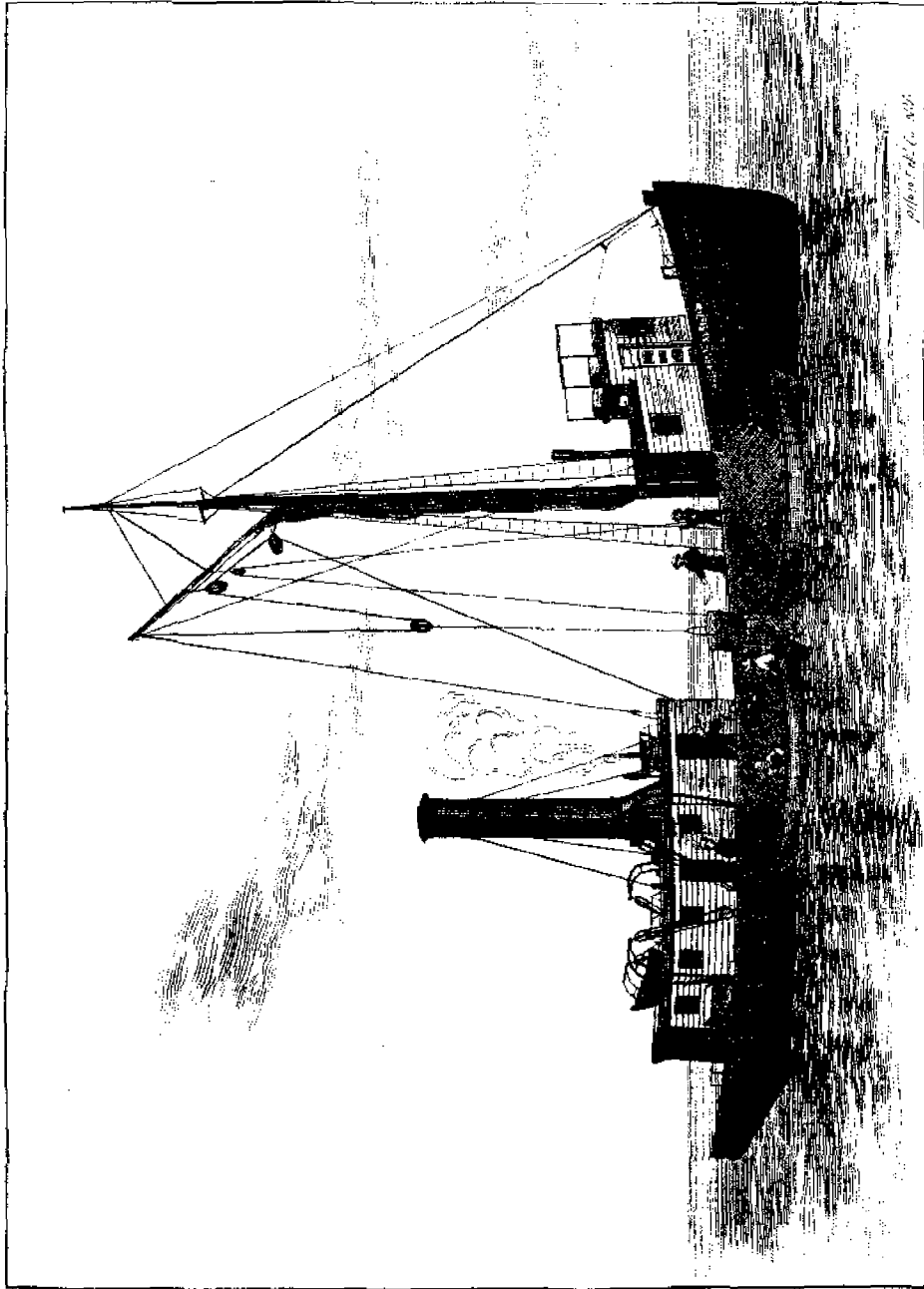

**THE MENHADEN FISHERY.**

Menhaden steamer bailing in the catch. (Seet. v, vol. 3, p. 349.)

From sketch by Capt. B. F. Conklin.



**THE MENHADEN FISHERY.**

Hand-seine fishing at Long Island, 1740 to 1850: setting the seine. (Seet. V, vol. 3, pp. 341, 368, 371.)

From sketch by Capt. B. T. Couklin

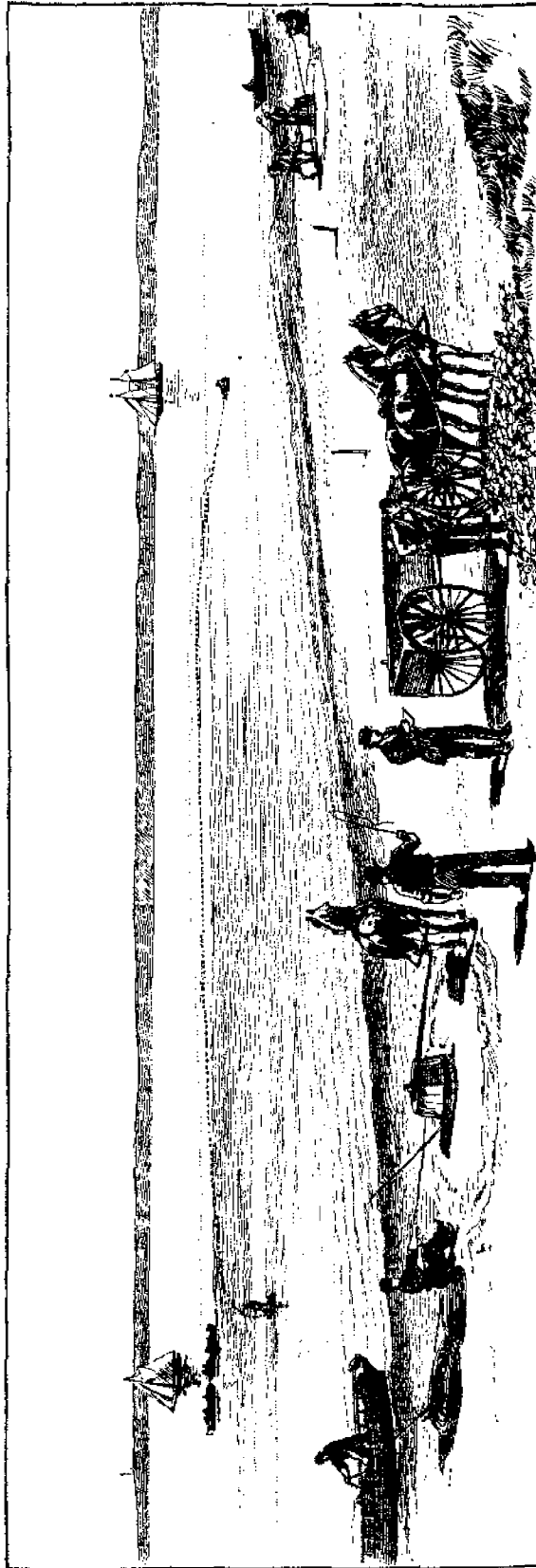

**THE MENHADEN FISHERY.**

Haul-seine fishing at Long Island, 1790 to 1850; hauling the seine. (Sect. v, vol. i, pp. 341, 368, 371.)

From sketch by Capt. R. F. Conklin.

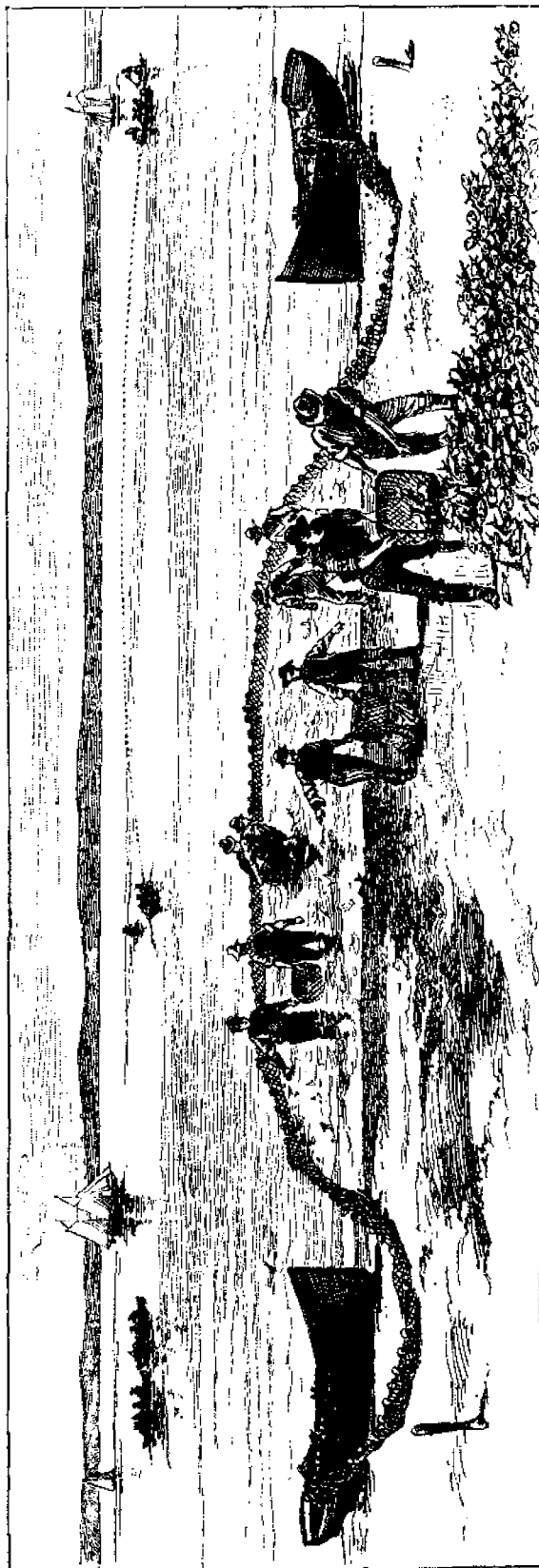

**THE MENHADEN FISHERY.**

Haul-seine fishing at Long Island, 1790 to 1850; taking out the fish. (Sect. v, vol. i, pp. 341, 368, 371.)

From sketch by Capt. B. F. Conkling.

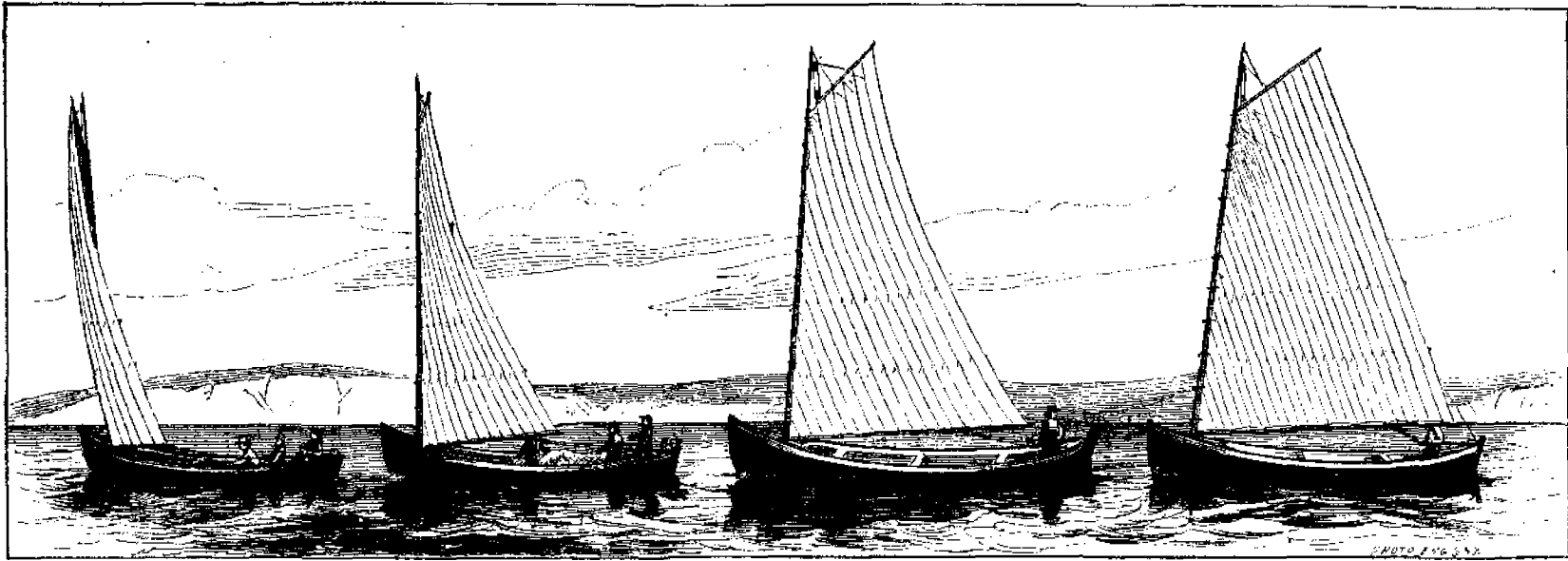

**THE MENHADEN FISHERY.**

Purse and mate boats, with two carry-aways, starting for the fishing grounds. (Sect. v, vol. i, pp. 334, 368.)

From sketch by Capt. R. F. Conklin.

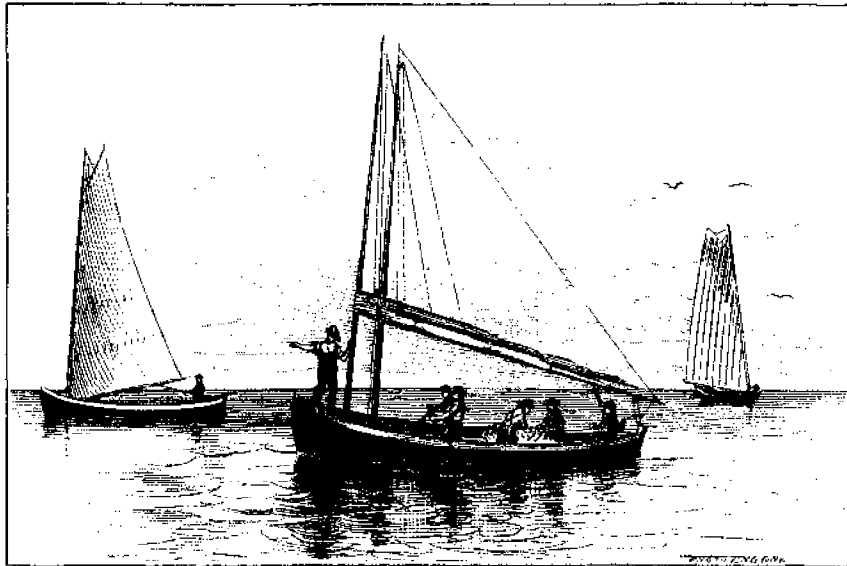

Fig. 1.—Going down to the fish.

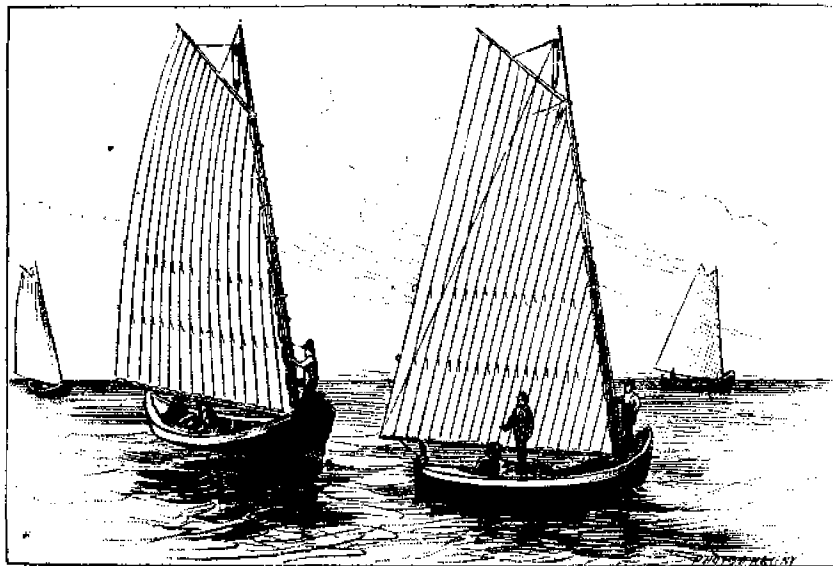

Fig. 2.—Working to windward of the fish.

**THE MENHADEN FISHERY.**

Purse and mate boats, and carry-away boats. (Sect. v, vol. i, pp. 334, 368.)

From sketches by Capt. B. F. Conklin.



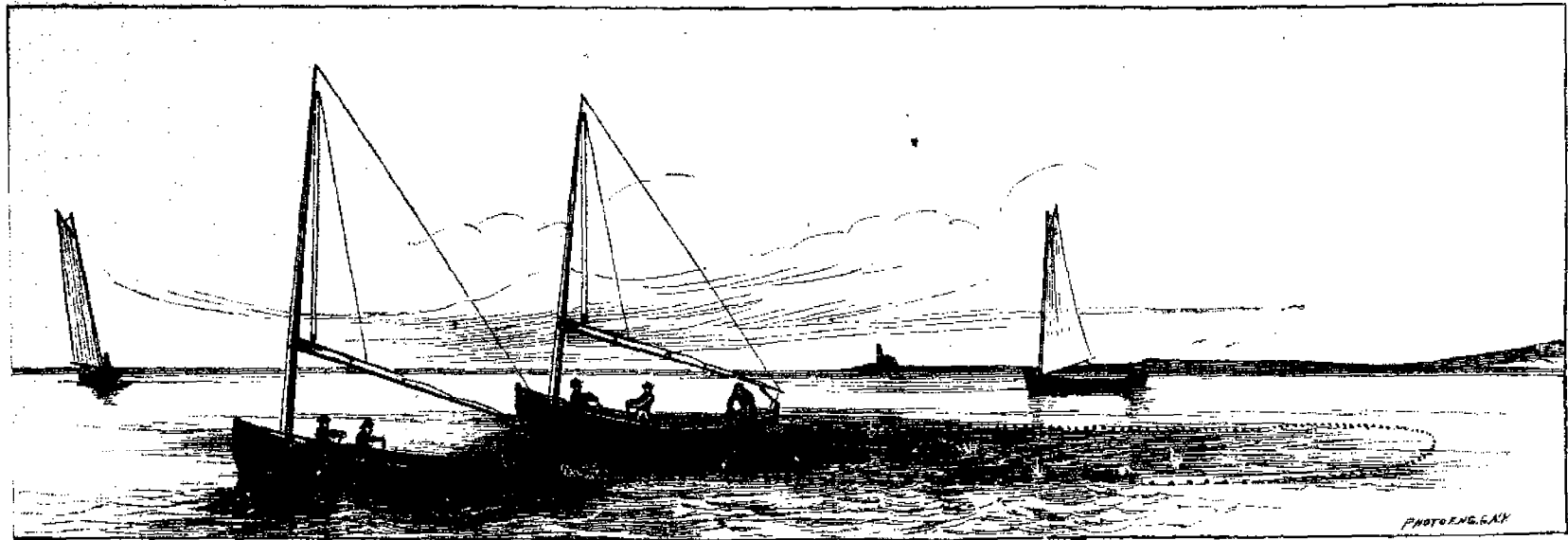

**THE MENHADEN FISHERY.**

Purse and mate boats encircling a school; carry-away boats in waiting. (Sect. v, vol. i, pp. 334, 368.)

From sketch by Capt. B. F. Conklin

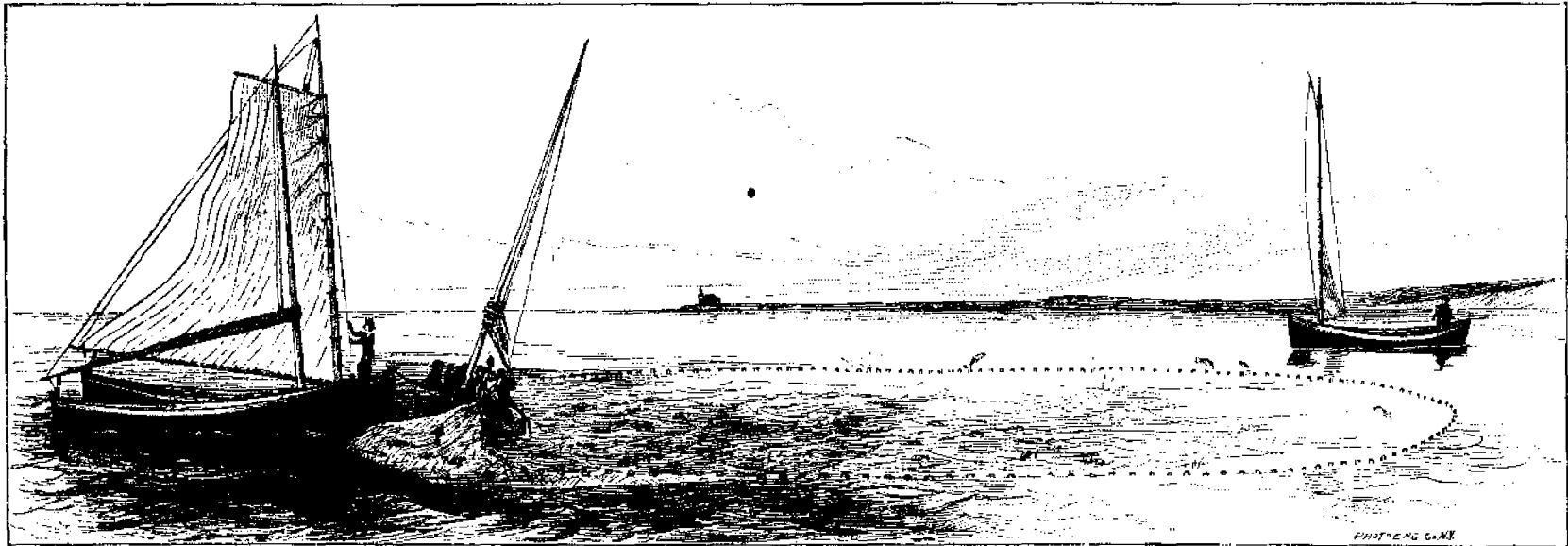

**THE MENHADEN FISHERY.**

Crew pursuing the seine; the fish striking the net. (Sect. v, vol. i, pp. 364, 368.)

From sketch by Capt. B. F. Conklin.

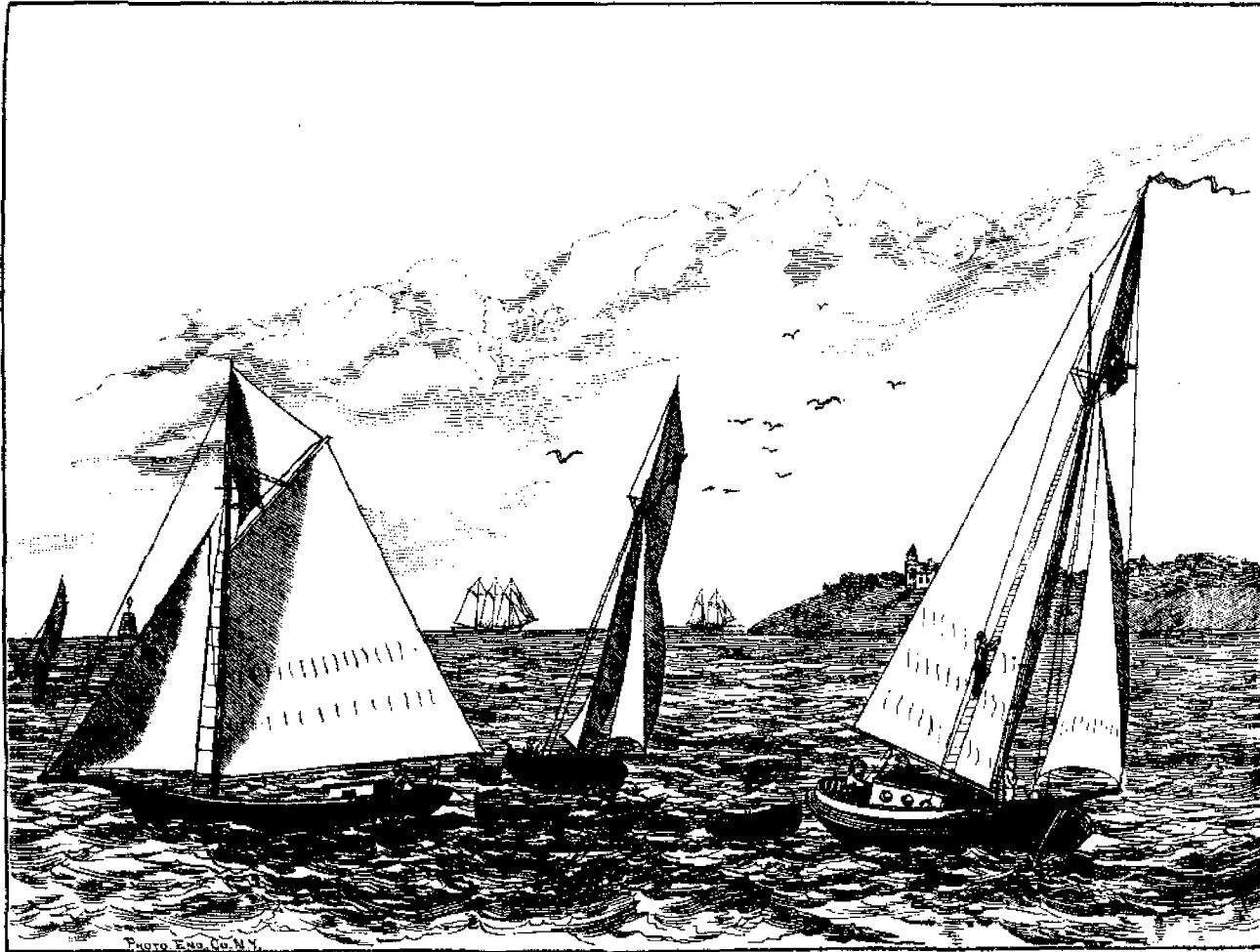

**THE MENHADEN FISHERY.**

Sloops cruising for fish; one sloop is for crew to live on and to tow seine-boats, others to carry fish to factory. (Sect. v, vol. i, pp. 334, 368.)

From sketch by Capt. R. F. Conklin.

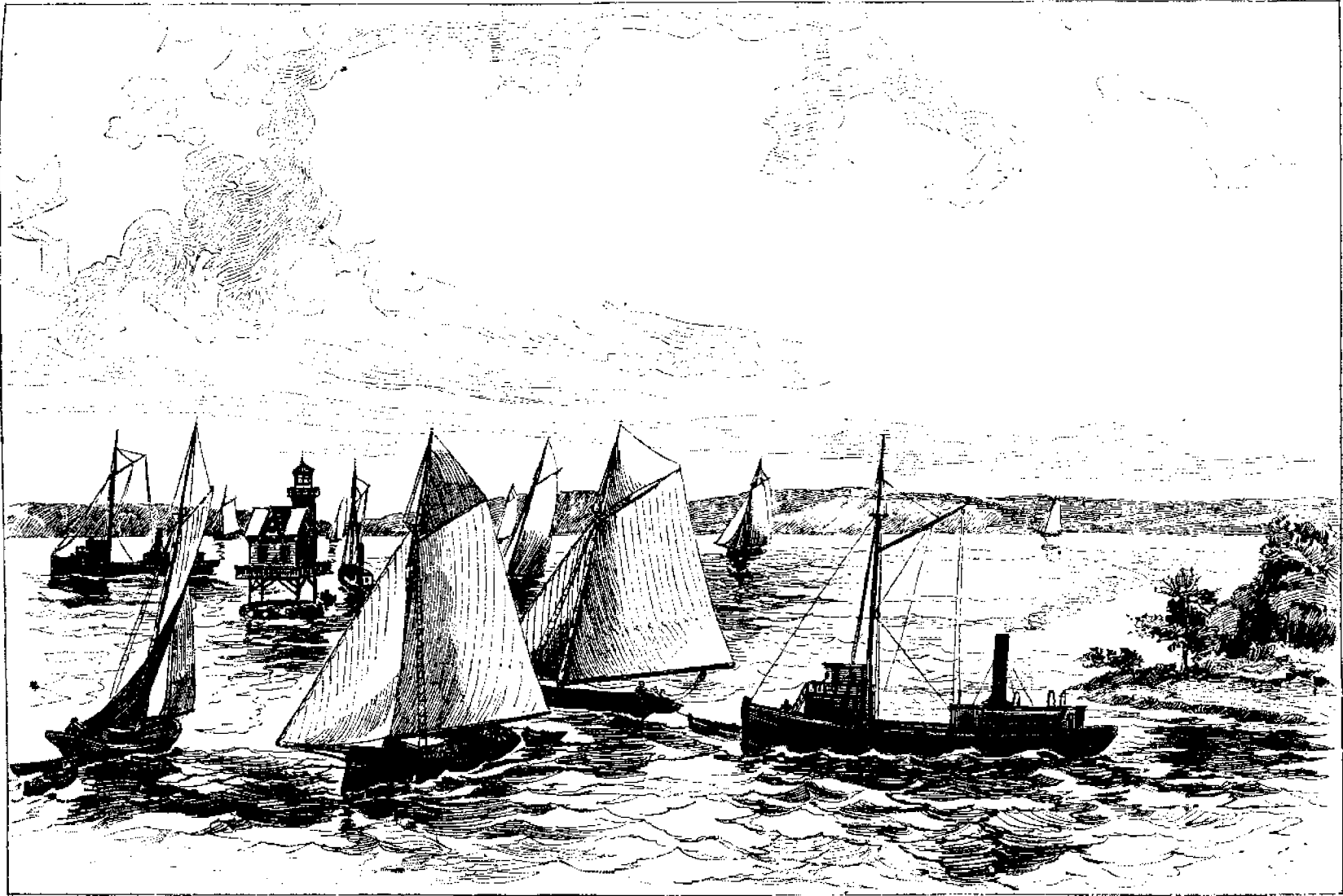

**THE MENHADEN FISHERY.**

Menhaden sloops and steamers in Gardiner's Bay, Long Island. (Sect. v, vol. i, p. 397.)

From sketch by Capt. B. F. Conklin

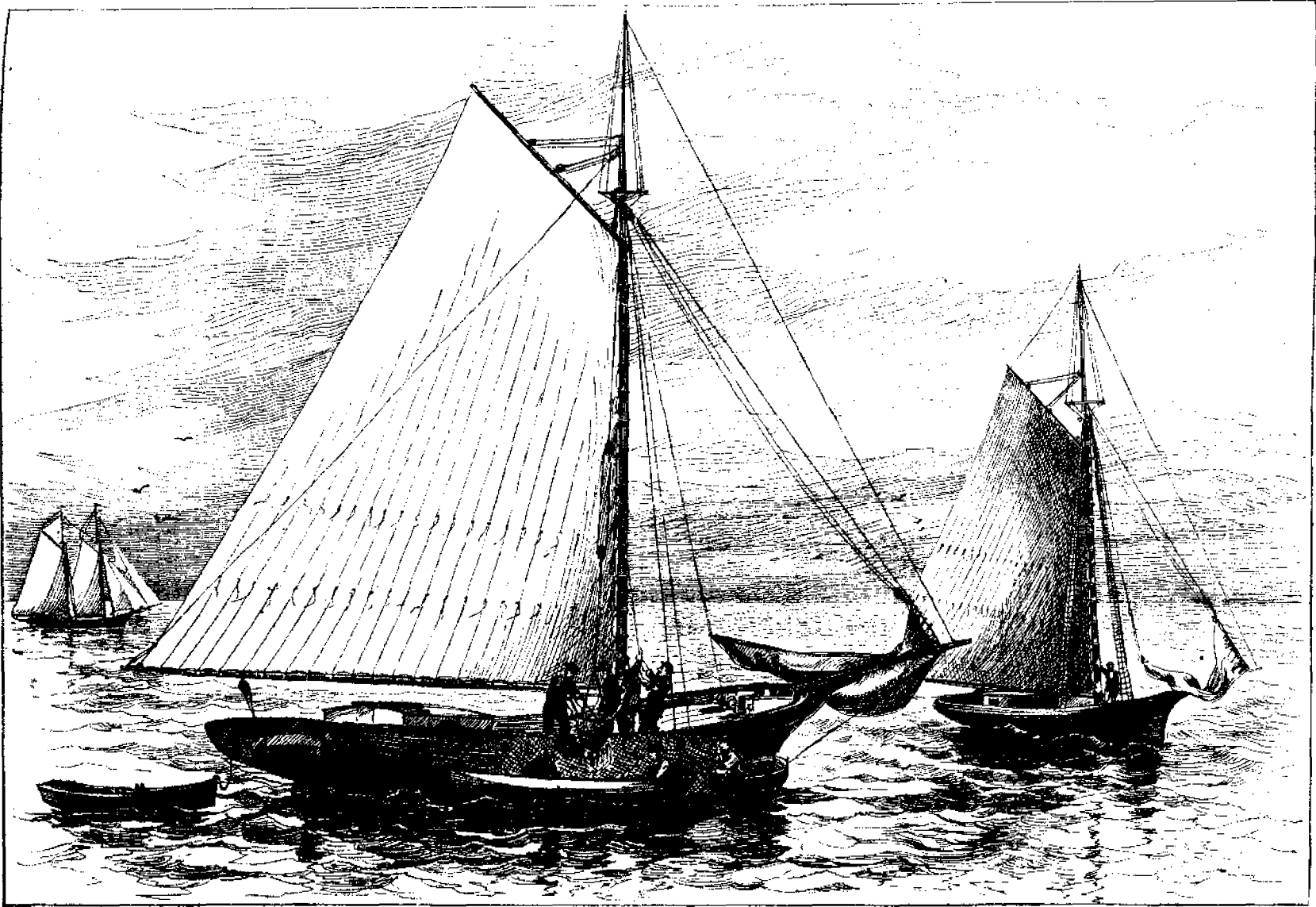

**THE MENHADEN FISHERY.**

Carry-away sloops; bailing in the catch. (Sect. v, vol. 1, pp. 376, 377.)

From sketch by Capt. B. F. Conklin.



**THE MENHADEN FISHERY.**

Fishermen signalling to shore crews the approach of a school of fish. (Sect. v, vol. i, p. 367.)

From sketch by Capt. B. F. Conklin.



**THE MENHADEN FISHERY.**

Crew of schooner, in old-style seine-boat, throwing the purse-seine around a school of fish. (Sect. v, vol. I, pp. 336, 338.)

From sketch by J. S. Ryder

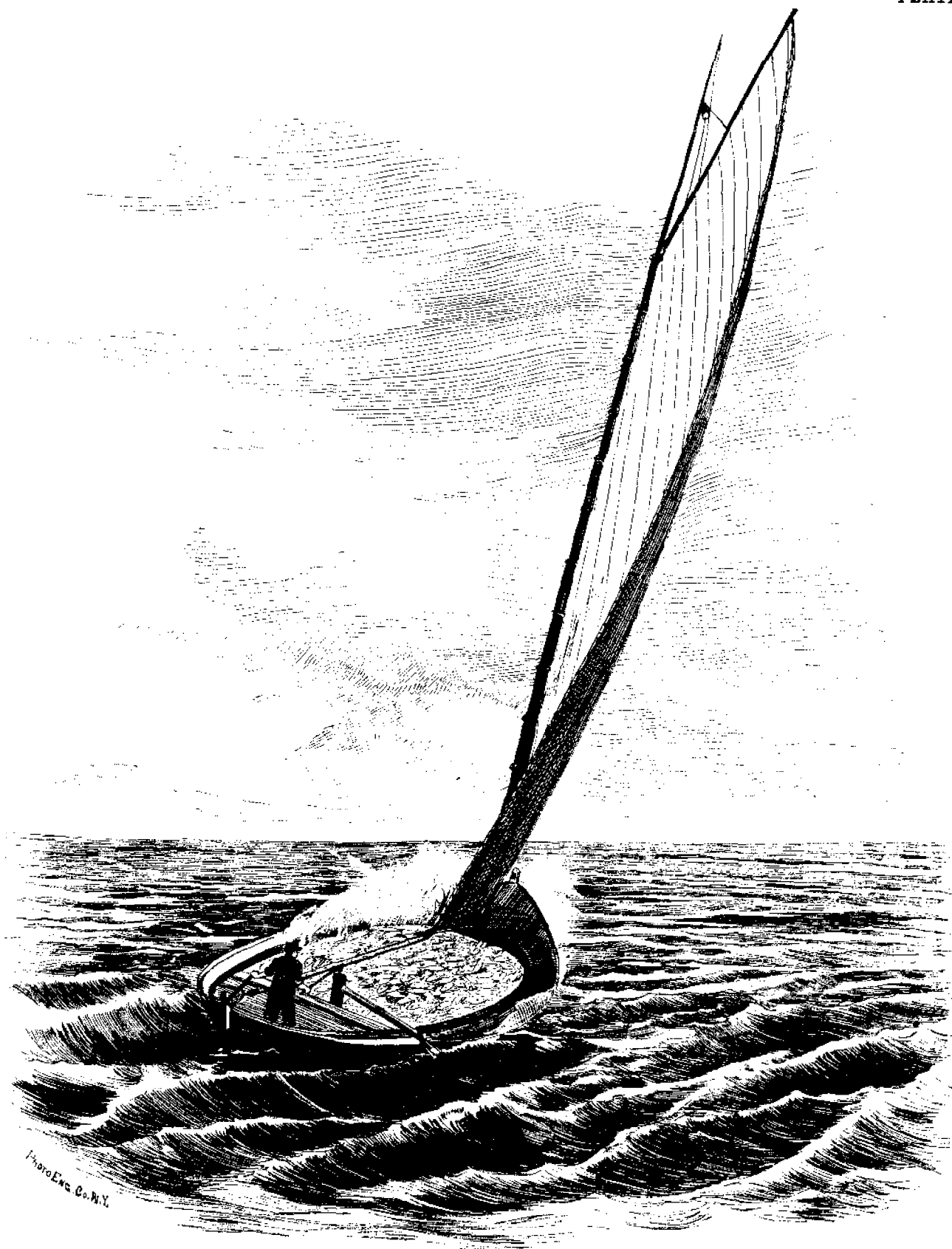

Photo Eng. Co. N.Y.

**THE MENHADEN FISHERY.**

Carry-away boat with haul of fish on the way to oil factory. (Sect. v, vol. i, p. 373.)

Sketch by Capt. B. F. Couklin.



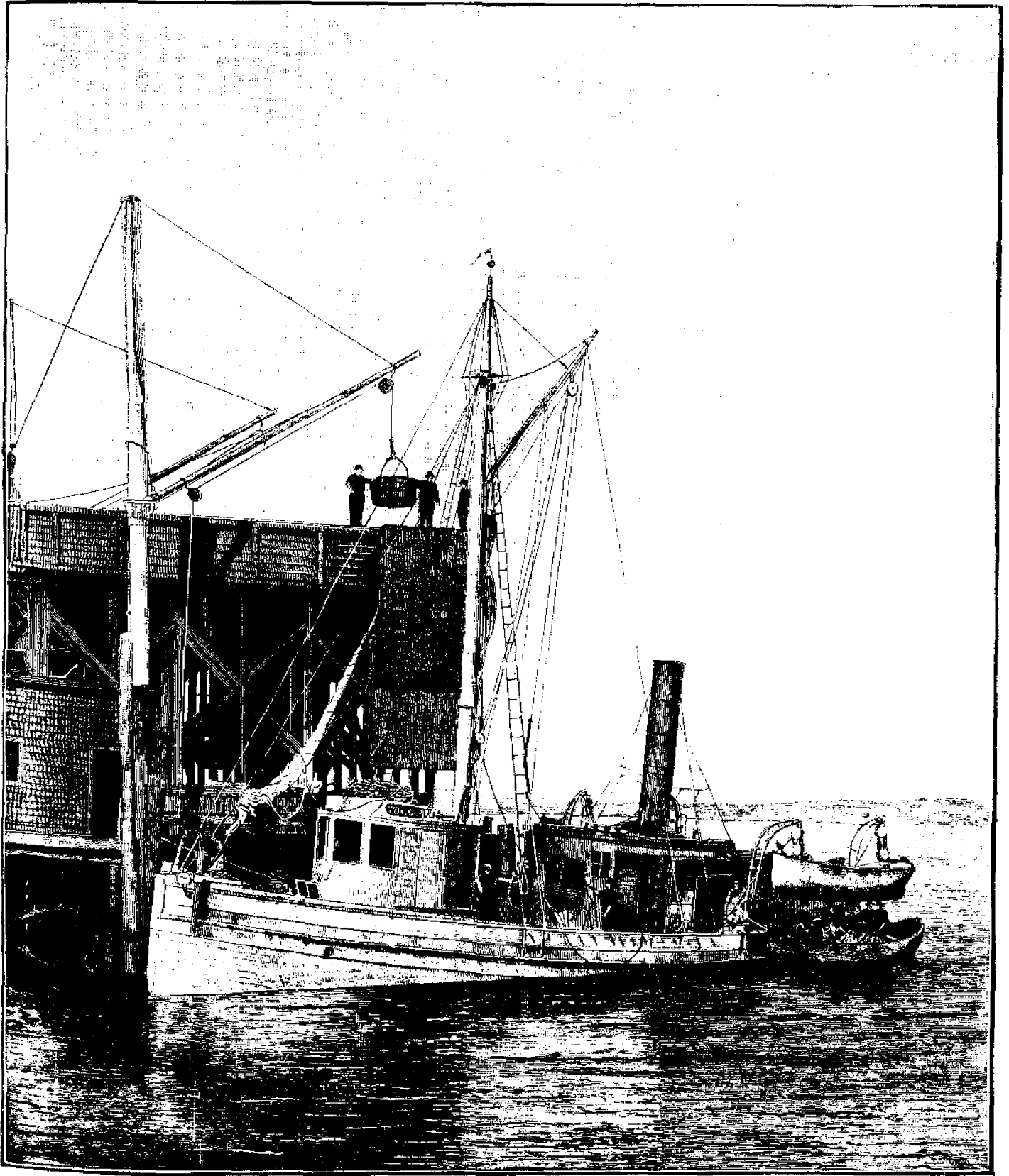

**THE MENHADEN FISHERY.**

Steamer discharging catch at oil and guano factory, Tiverton, R. I. (Sect. v, vol. i, p. 337.)

From a photograph by T. W. Sullie.

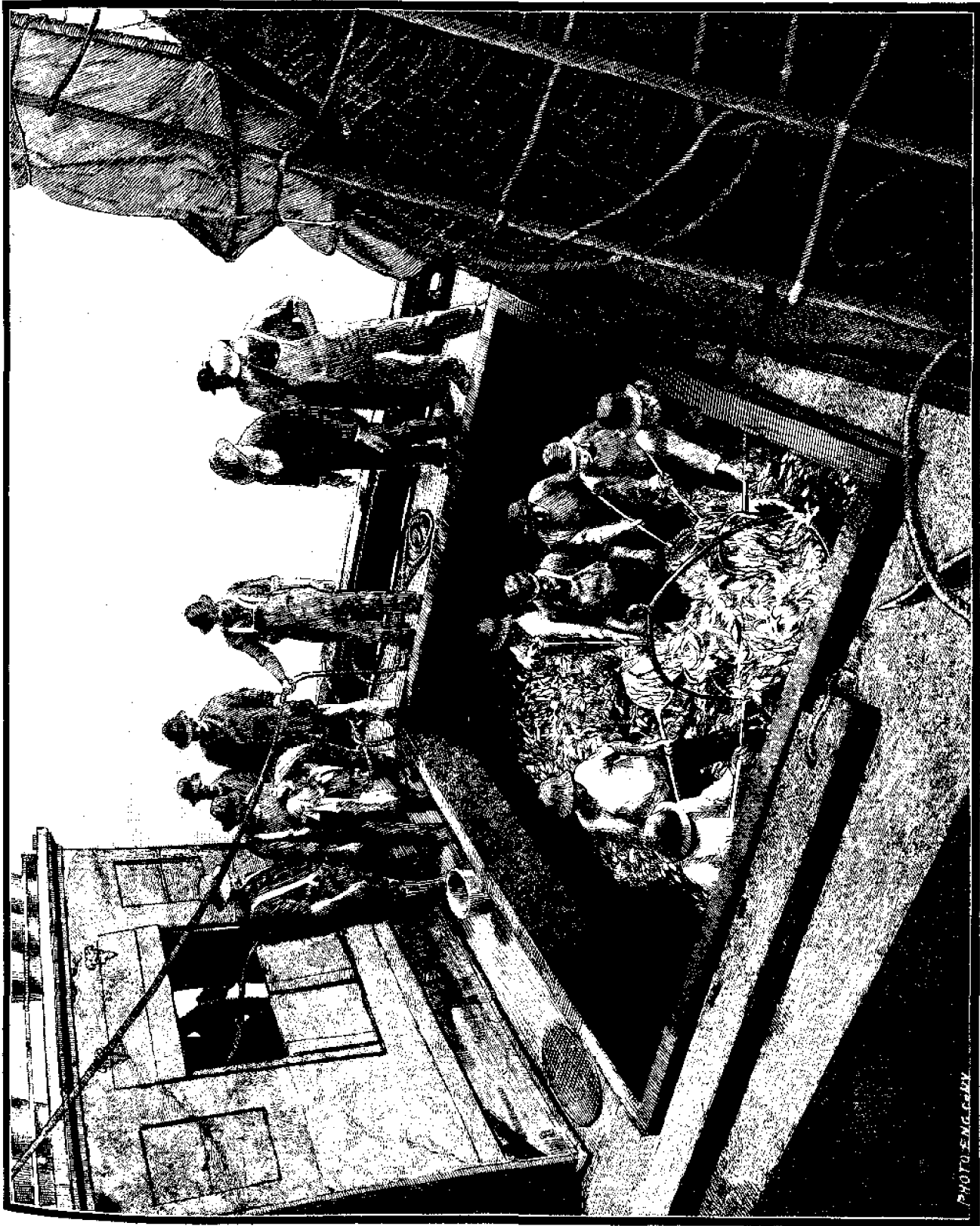

**THE MENHADEN FISHERY.**

Gang of Portuguese in hold of steamer filling the hoisting-tubs. (Seet. v, vol. 1, p. 317.)

From a photograph by T. W. Scullie.

PHOTO-ENG. CO.

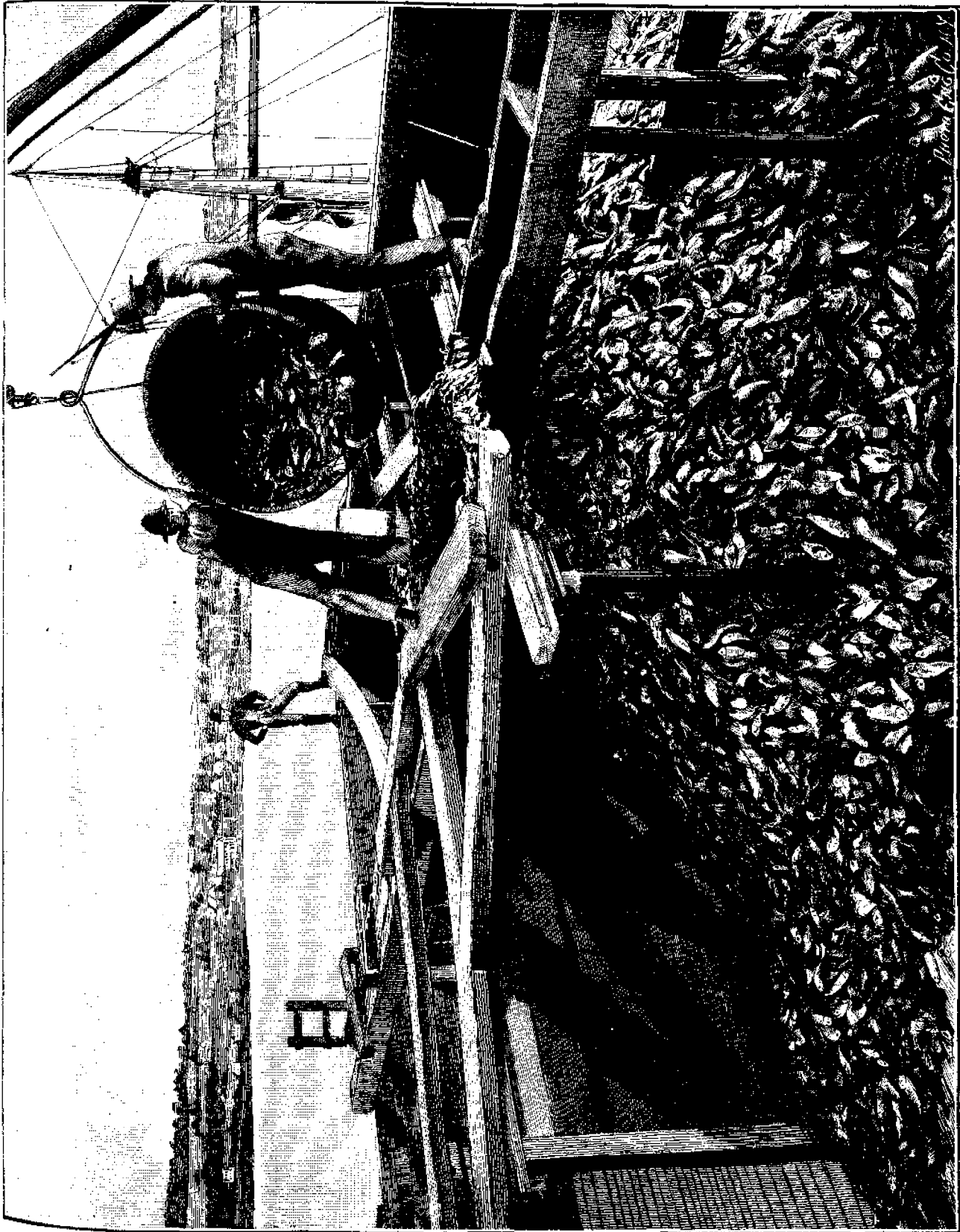

**THE MENHADEN FISHERY.**

Fish pens on top floor of factory. The fish are led through a trough to the cooking-tanks. (Sect. v, vol. i, p. 317.)  
From a photograph by T. W. Shailor.

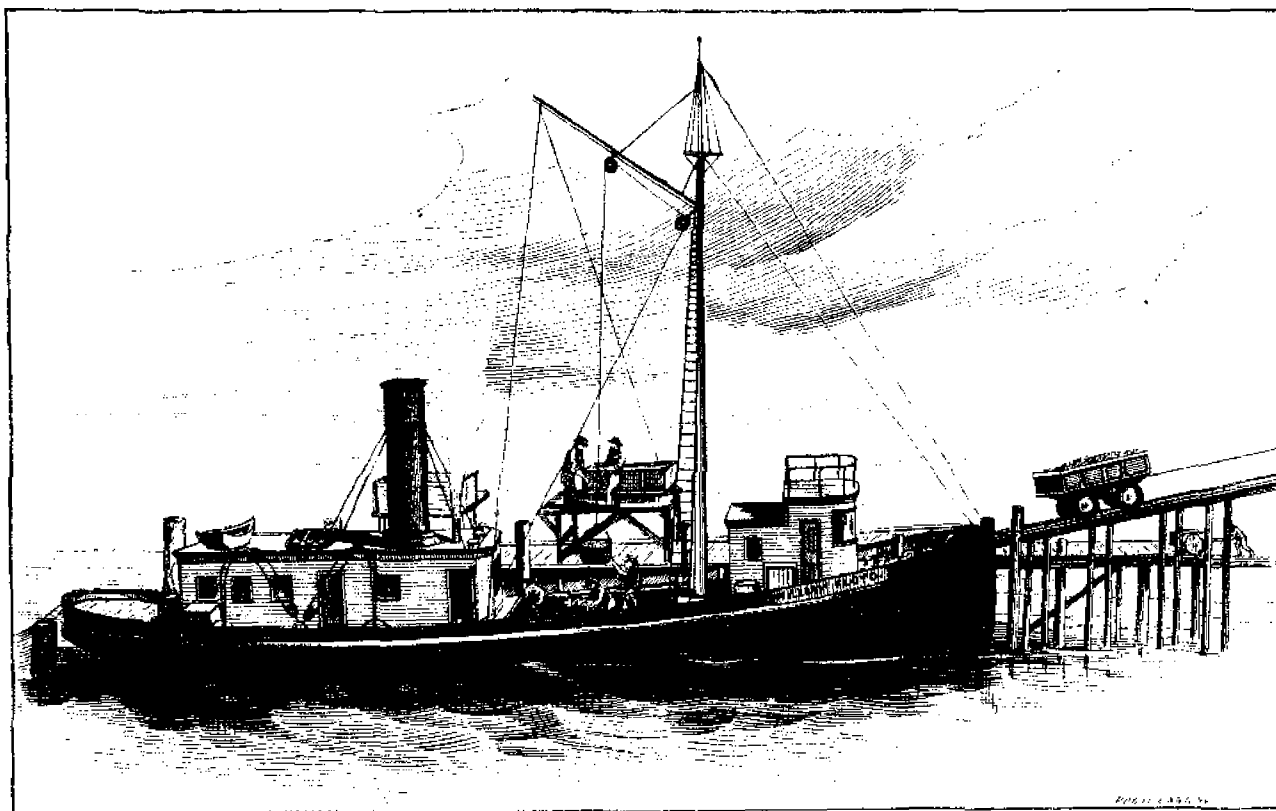

**THE MENHADEN FISHERY.**

Steamer discharging its catch at oil and guano factory. Inclined railway to carry fish to cooking-tanks. (Sect. v, vol. i, p. 337.)

Sketch by Capt. B. F. Conklin.

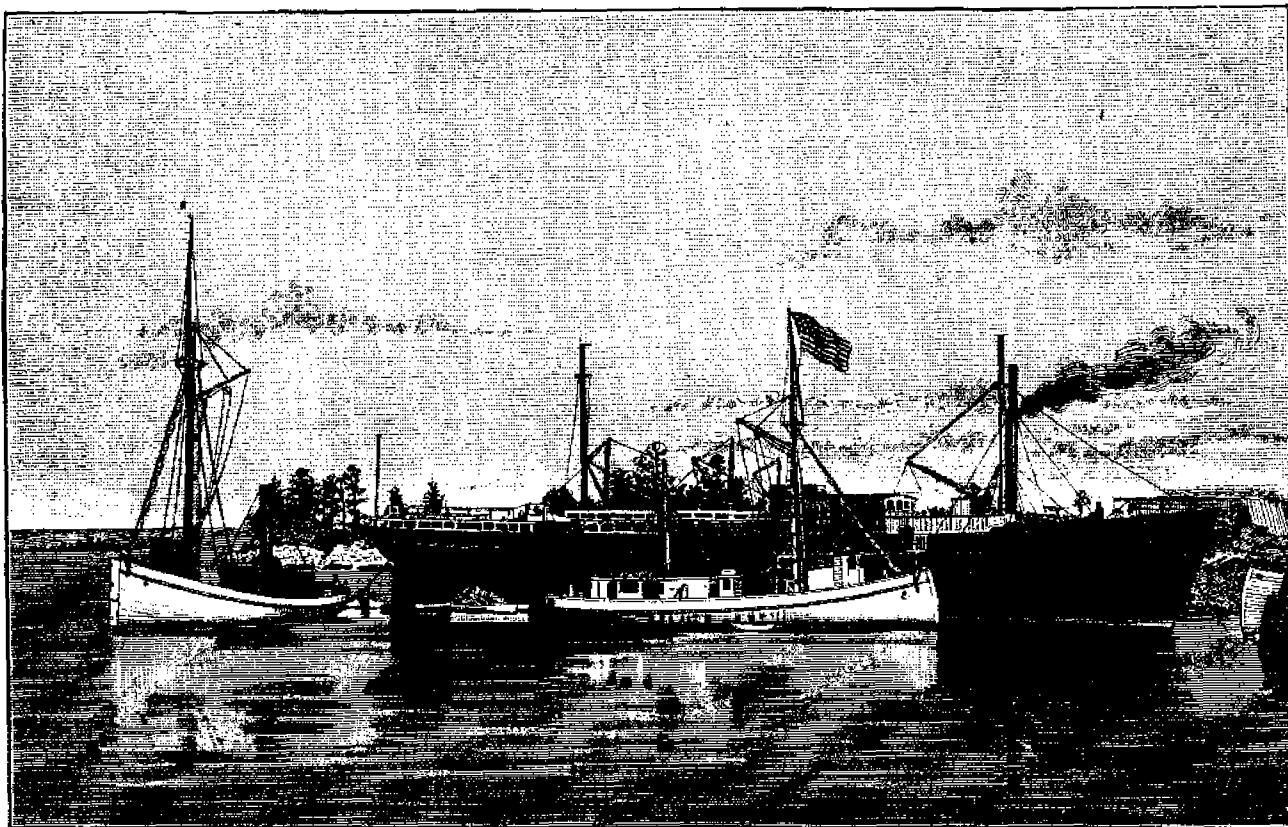

**THE MENHADEN FISHERY.**

Floating factory; an old vessel fitted as an oil factory, moved from place to place near the fishing-grounds. (Sect. v, vol. i, pp. 345, 378.)

Drawing by H. L. Todd.

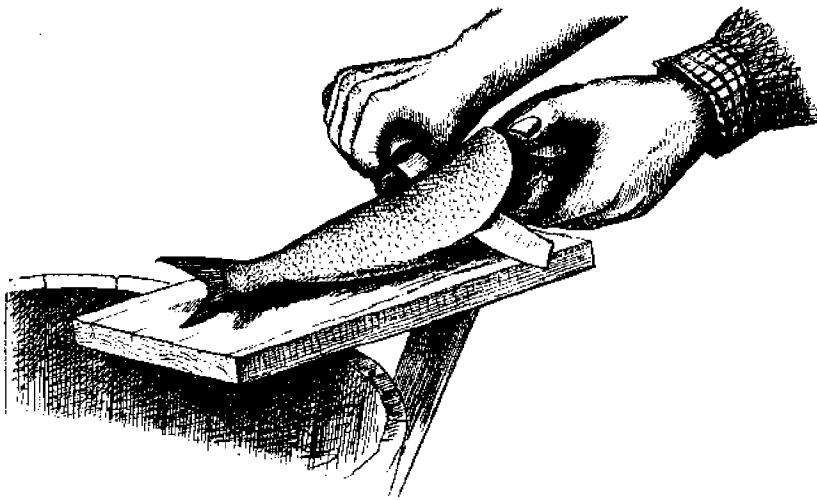

**THE MENHADEN FISHERY.**

Slivering menhaden for bait. (Sect. v, vol. i, pp. 282, 348-356.)

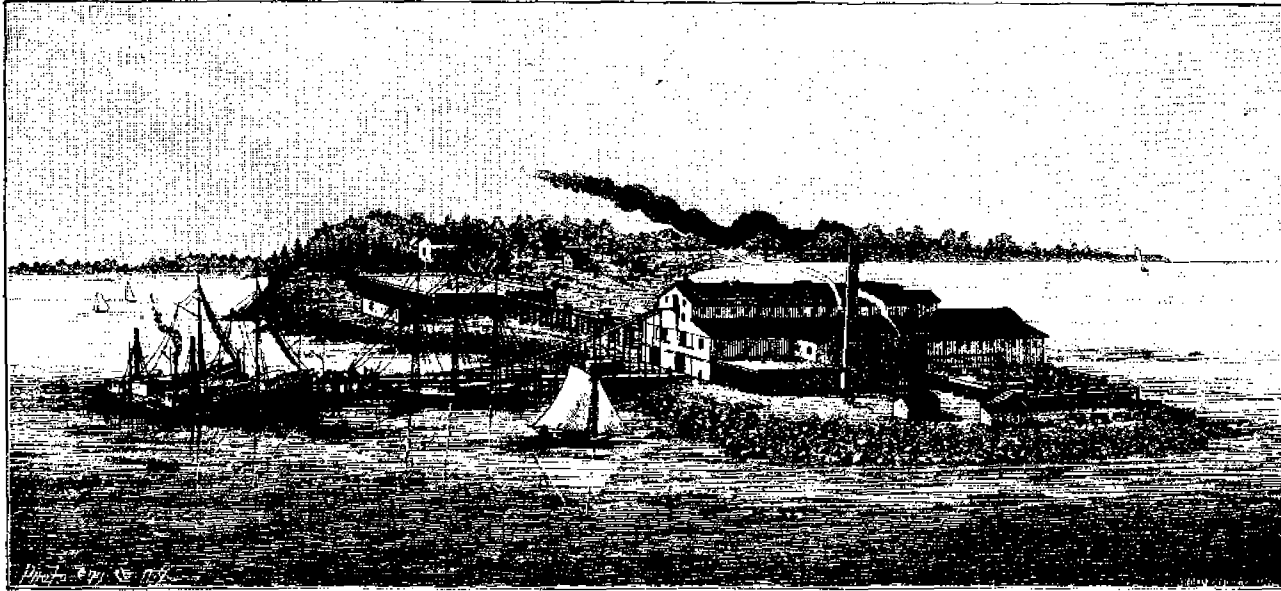

### THE MENHADEN FISHERY.

Menhaden oil and guano factory at Milford, Conn. : steamers unloading fish at the wharf; incline railway for carrying fish to cooking-tanks on upper floor of factory; oil-tanks and storage-sheds in foreground; platform for drying scrap in rear of factory connected with building by elevated railway. (Sect. v, vol. i, p. 342.)

From a photograph.

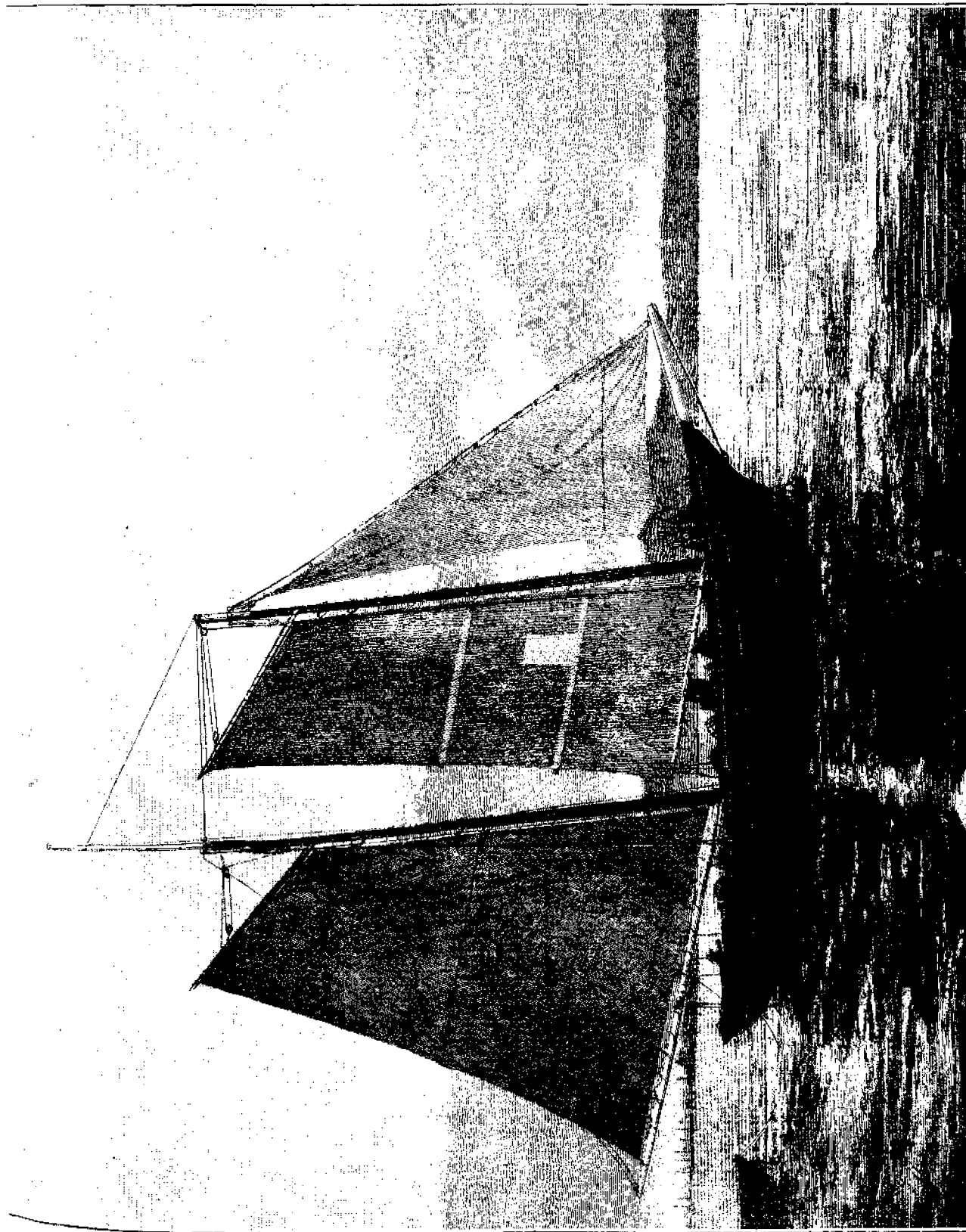

**THE HERRING FISHERY.**

Herring schooner bound for Wood Island, Maine; outfit of salt and barrels on deck. (Sect. V, vol. 1, p. 436.)

From a photograph by T. W. Smilie.



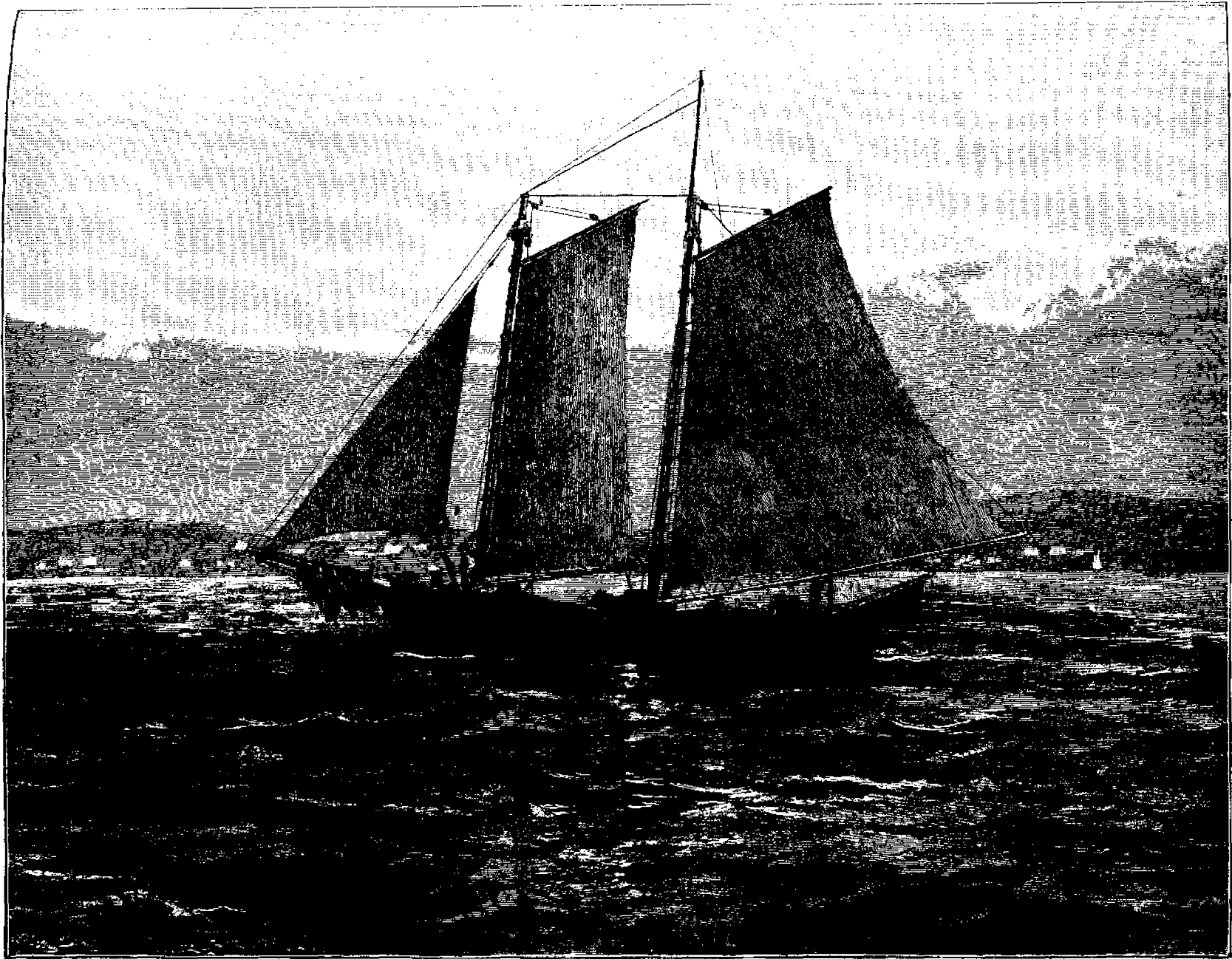

**THE HERRING FISHERY.**

Herring pinkey bound for the fishing grounds; nets hanging over bowsprit and stern; net dories on deck. (Sect. v, vol. i, p. 426.)

From a photograph by T. W. Smilie.

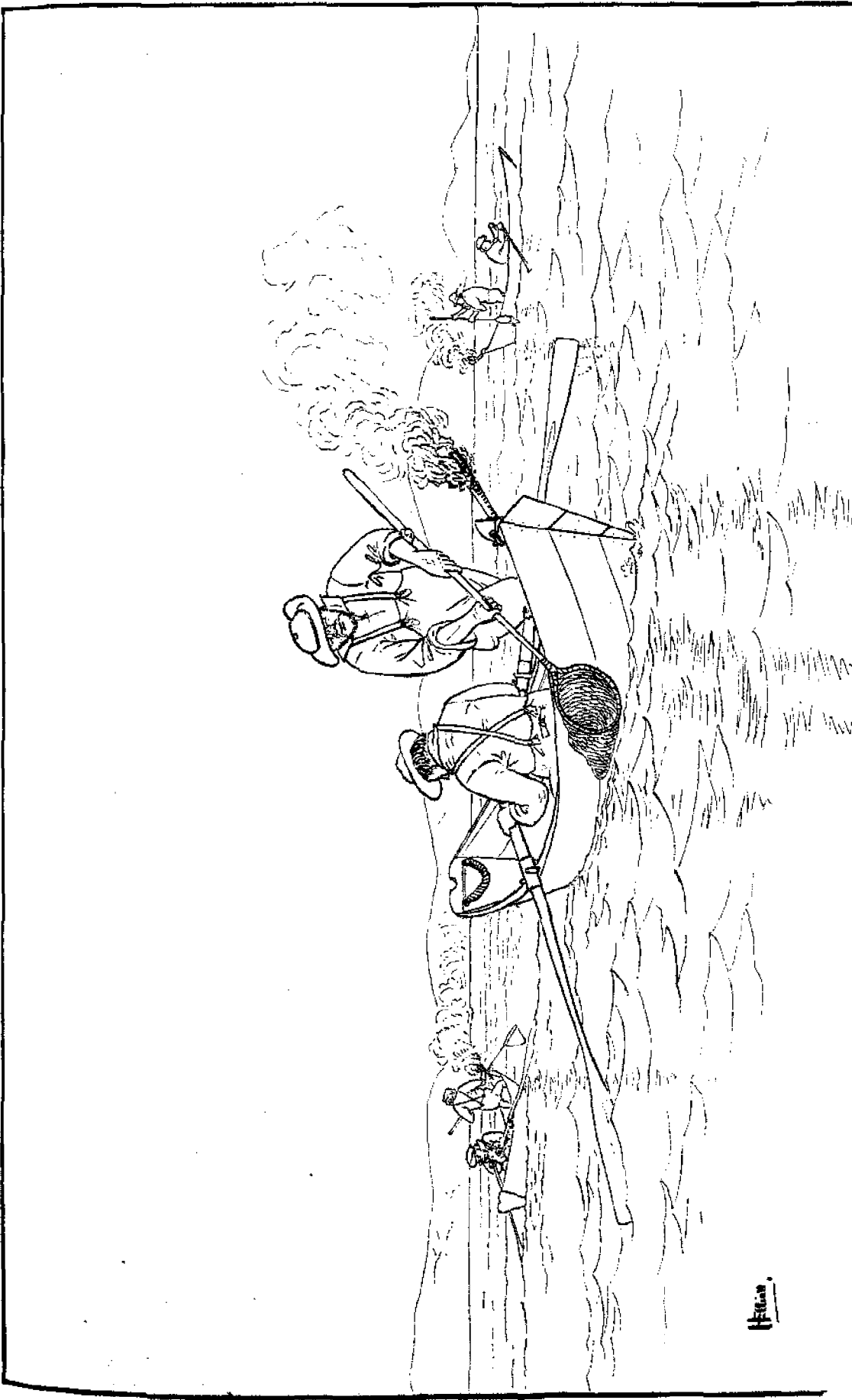

**THE HERRING FISHERY.**

Torching at night for spearing or small herring in Ipswich Bay, Massachusetts. (Sect. v, vol. i, p. 428.)  
From sketch by J. S. Ryder.

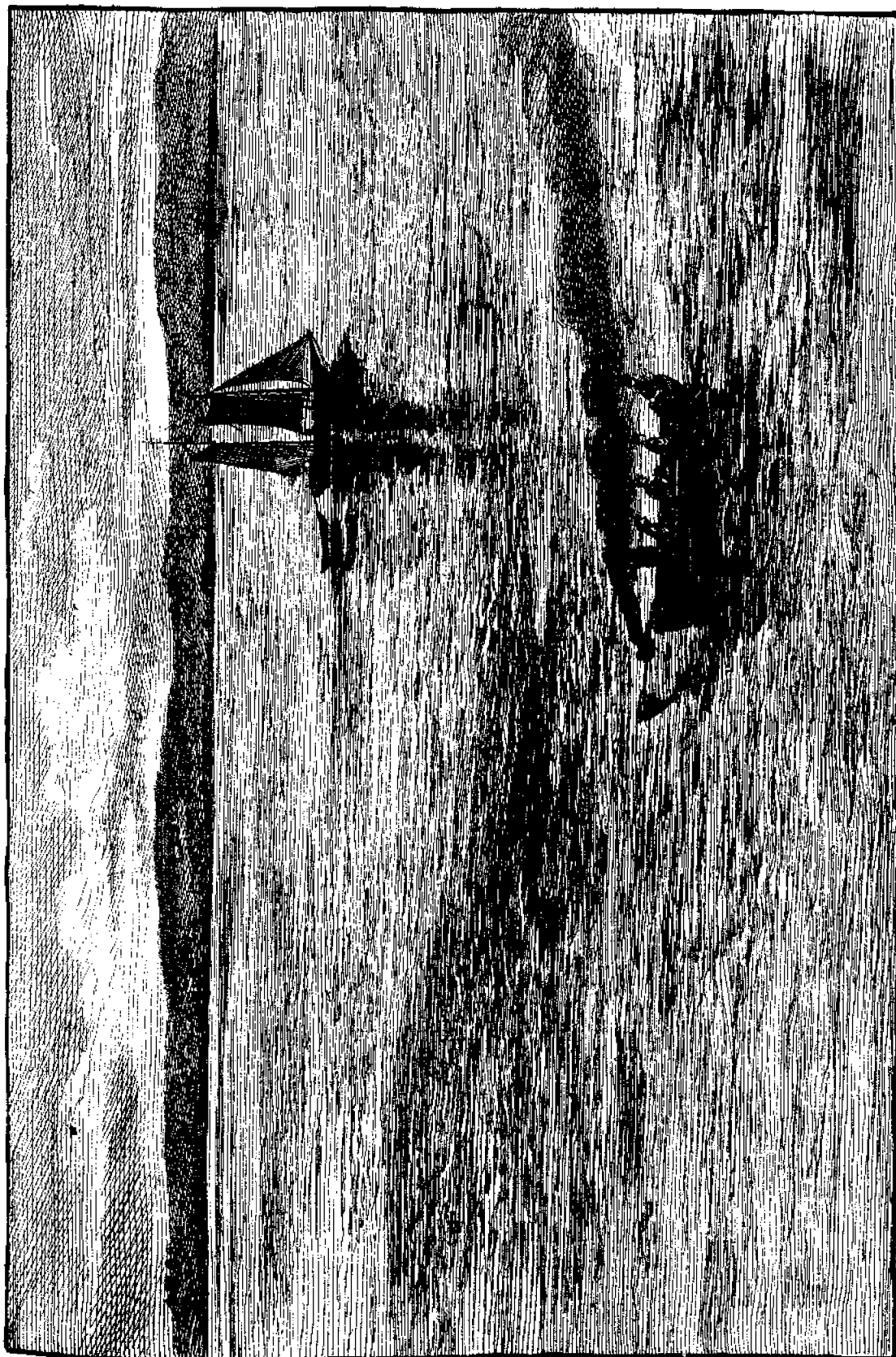

**THE HERRING FISHERY.**

Torching herring at night near Eastport, Maine; birch-bark fire burning in the "dragon" at low of boat. (Sect. 6, vol. 1, p. 429.)  
From a photograph by T. W. Smilie.



### THE HERRING FISHERY.

Fishermen mending herring gill-nets at House Island, Casco Bay, Maine. (Sect. v, vol. i, p. 430.)

From a photograph by T. W. Smilie.



**THE HERRING FISHERY.**

Irish fishermen of Boston picking their herring nets in Gloucester Harbor. The typical "Irish Market Boat." (Sect. v. vol. i, p. 430.)

From a photograph by T. W. Smilie.

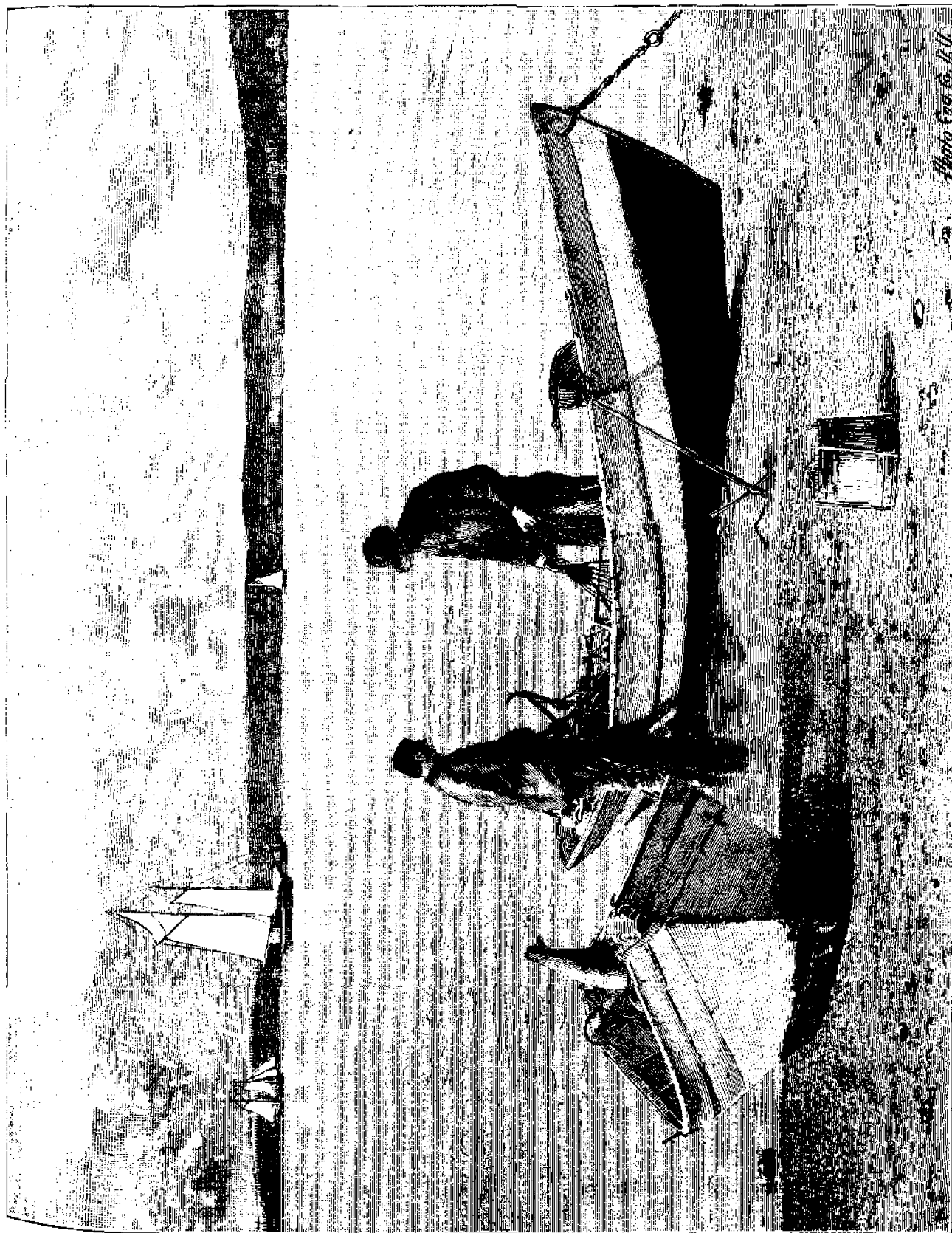
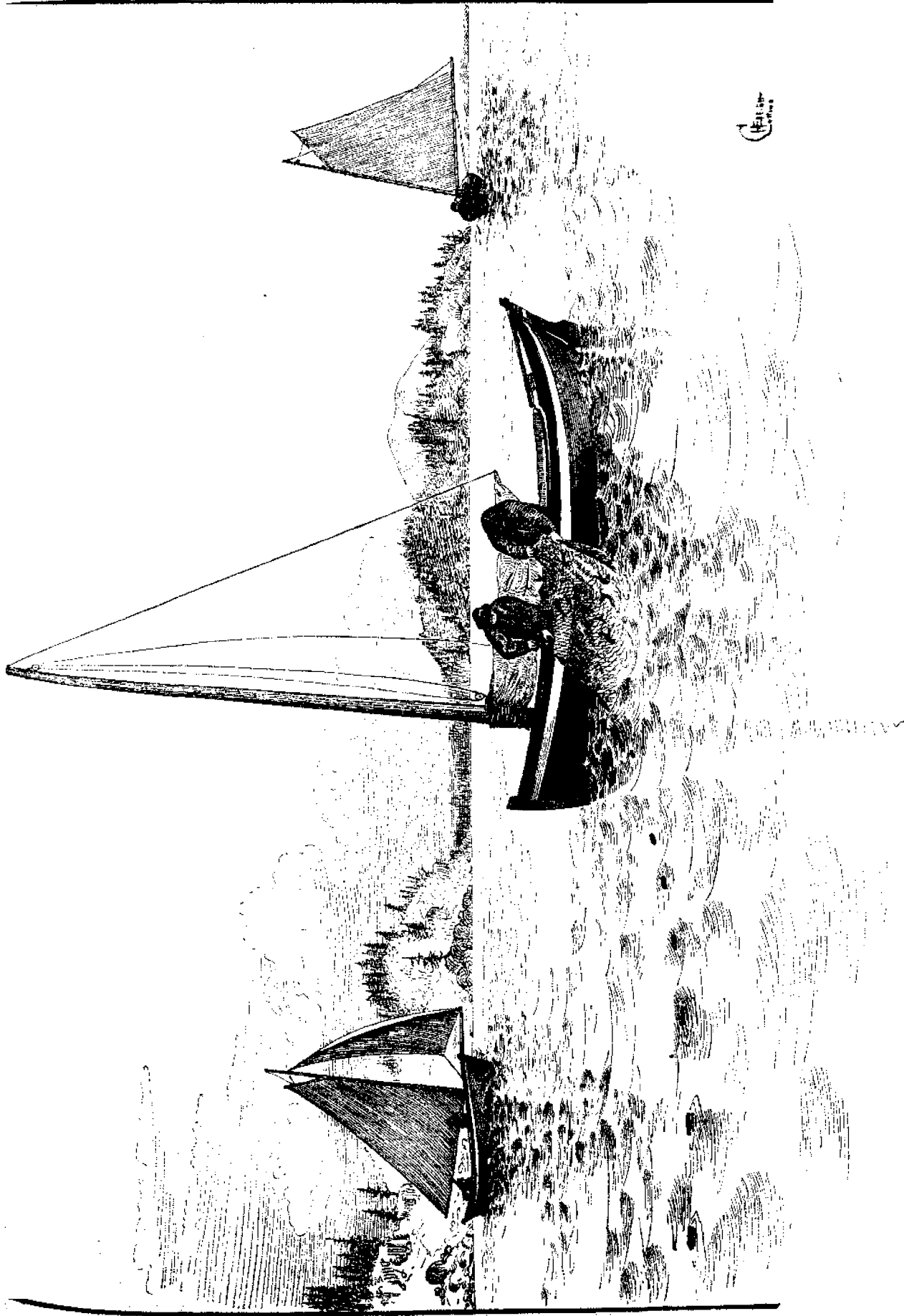

Photo. Geo. S. Hill

**THE HERRING FISHERY.**

Cape Ann herring fish-men hauling their gill-nets after a night's fishing. (Sect. v, vol. i, p. 430.)  
From a photograph by T. W. Suttie.



**THE HERRING FISHERY.**

Fishermen in Groddy boat hauling herring gill-nets. (Sect. v, vol. i, p. 430.)

Drawing by H. W. Elliott and Capt. J. W. Collins.



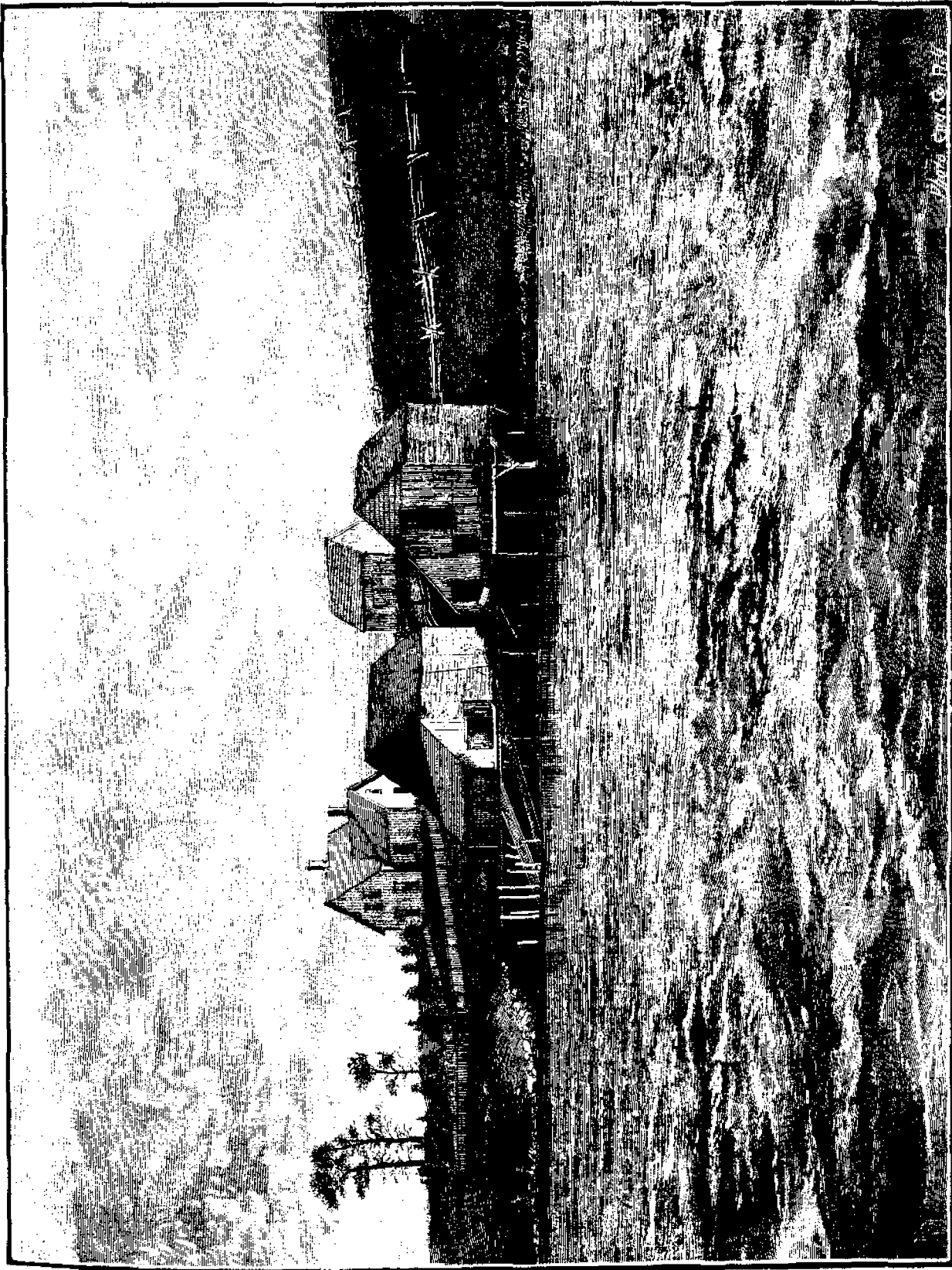

**THE SMOKED-HERRING INDUSTRY.**

Boat landing, fish houses, herring smoke-house, fisherman's dwelling and farm. (Sect. v, vol. i, p. 476.)

From a photograph by T. W. Smilie.



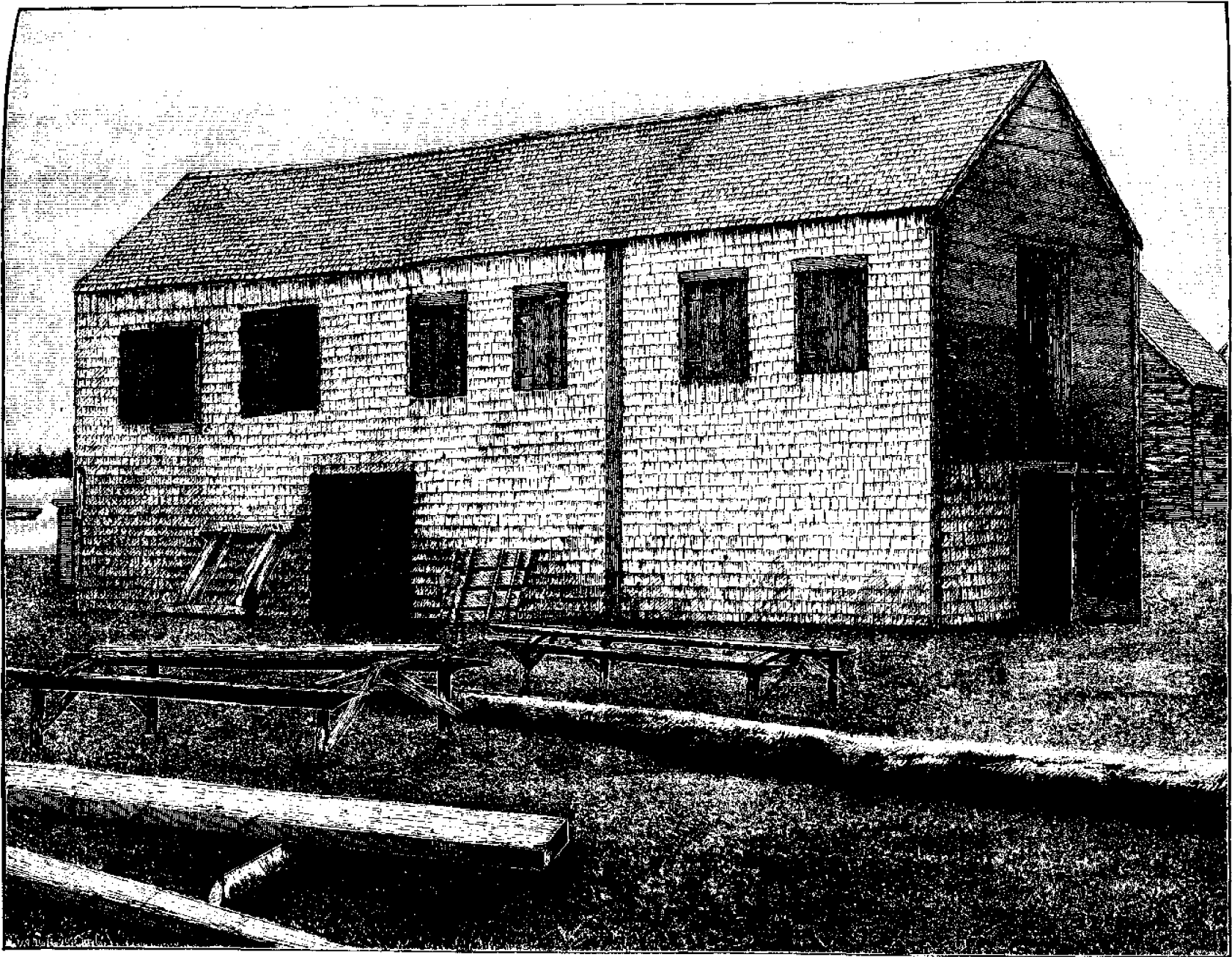

**THE SMOKED-HERRING INDUSTRY.**

Old style herring smoke-house (without ventilation on roof), at Leubee, Me. (Sect. v, vol. i, p. 476.)

From a photograph by T. W. Sullie.

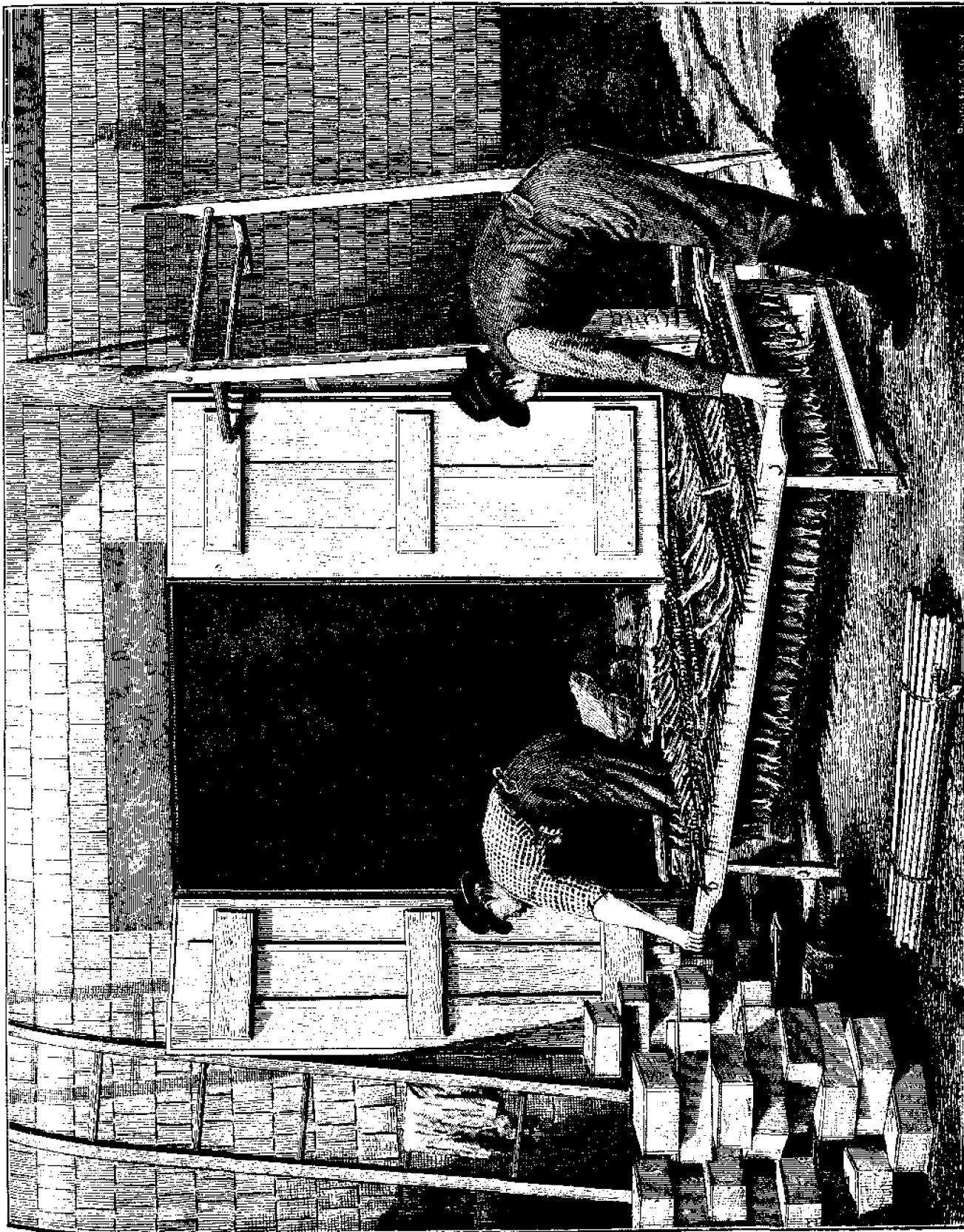

**THE SMOKED-HERRING INDUSTRY.**

Herring-horse loaded with smoked fish strung on sticks. (Sesl. V. vol. 4, p. 475.)

From a photograph by T. W. Swallow.

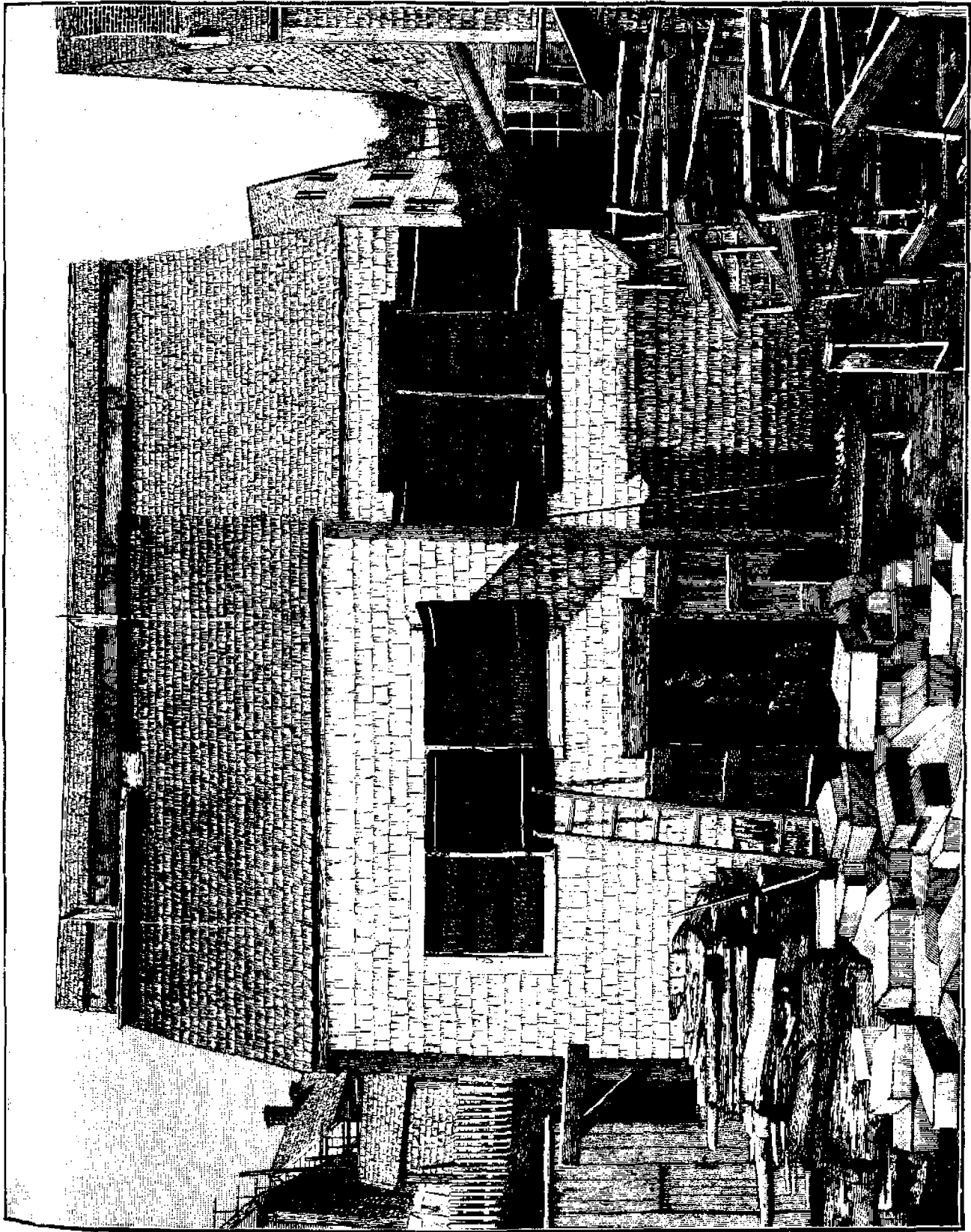

**THE SMOKED-HERRING INDUSTRY.**

Herring smoke-house at Eastport, Me.; smoke ventilators in roof; sticks of herring inside. (Seal, V, vol. 1, p. 480.)

From a photograph by T. W. Smith.

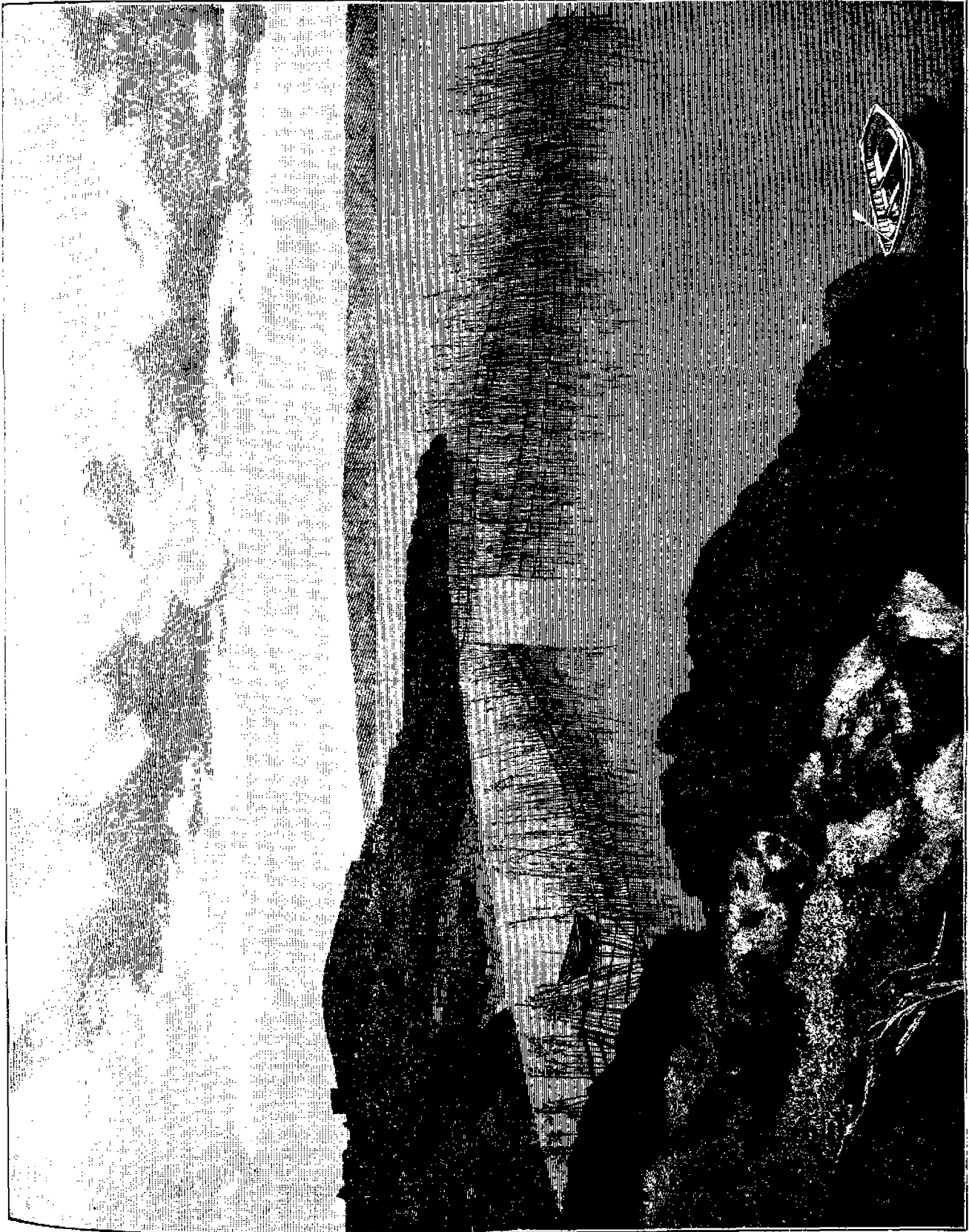

**THE SARDINE INDUSTRY.**

Shore herring weir near Eastport, Me.; the common form of brush weir. (Sect. v, vol. i, p. 501.)  
From a photograph by T. W. Saffin.

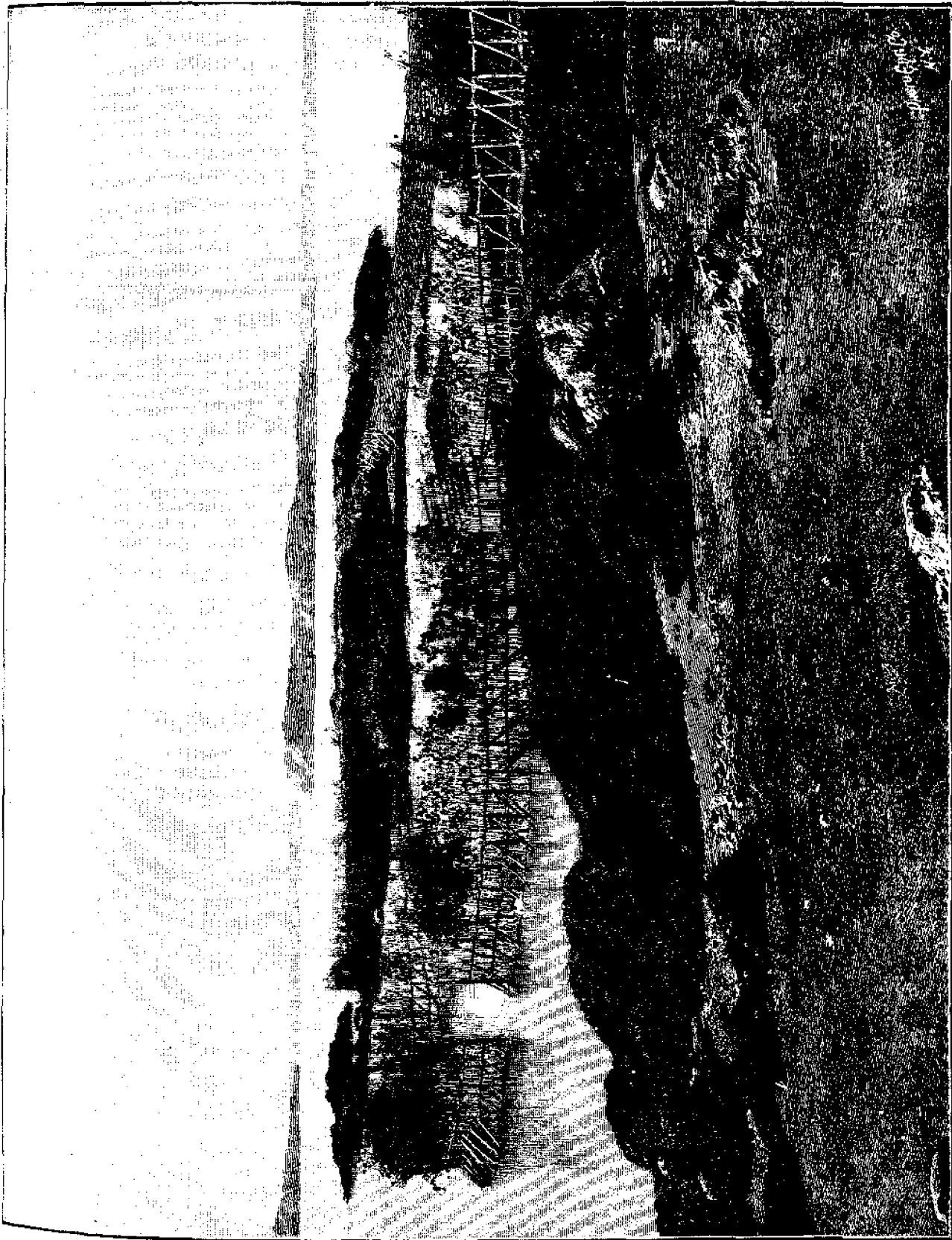

**THE SARDINE INDUSTRY.**

Bar herring-weir near Eastport, Me.; escape of fish prevented by receding tide. (Sect. v. vol. 1, p. 500.)

From a photograph by T. W. Spillie.



**THE SARDINE INDUSTRY.**

Channel herring-weir near Eastport, Me.: controls channel between islands. (Sect. v, vol. i, p. 501.)

From a photograph by T. W. Smith.



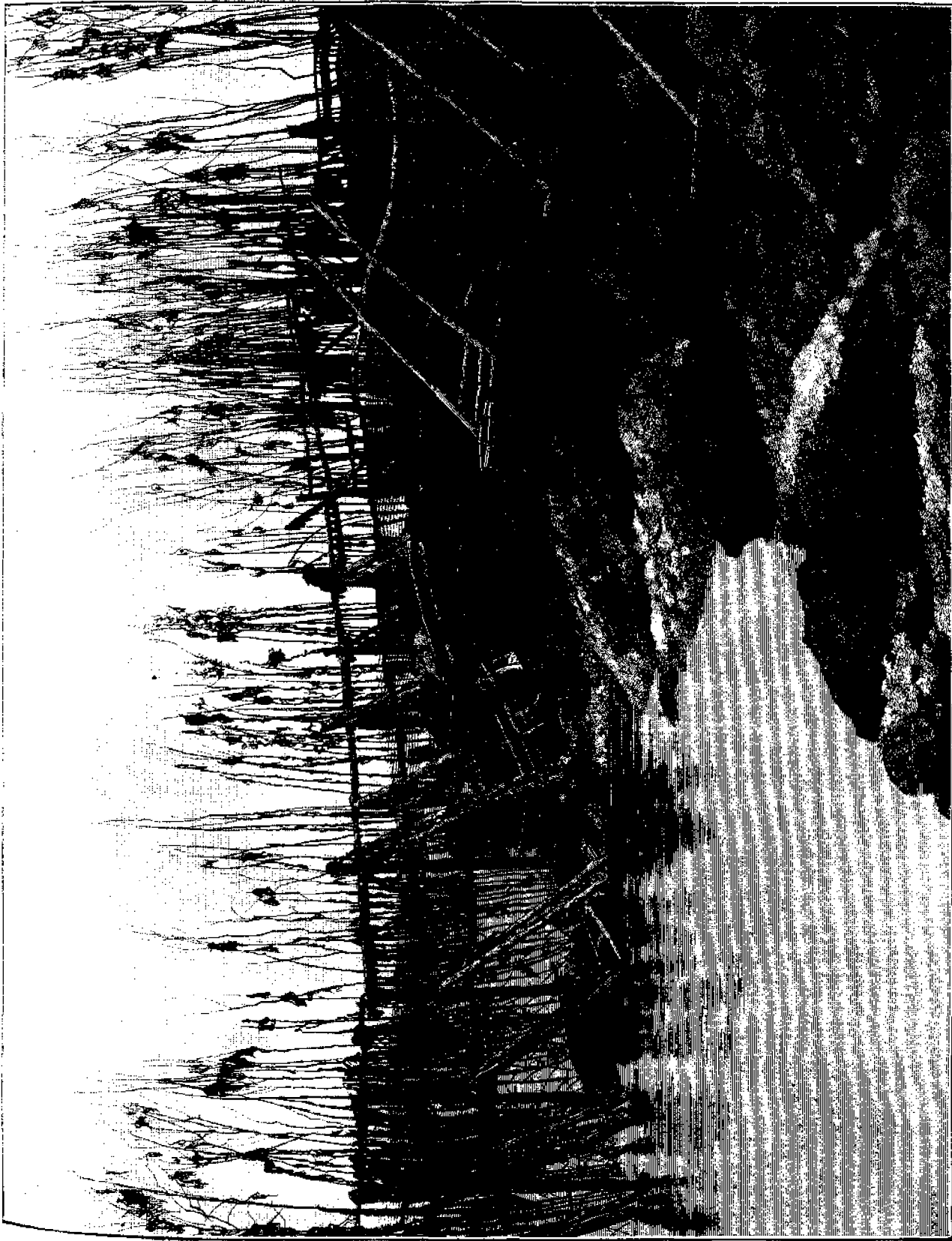

**THE SARDINE INDUSTRY.**

Section of ballasted herring-weir near Eastport, Me.; for rocky bottom. (Sect. v, vol. i, p. 502).  
From a photograph by T. W. Stullie.

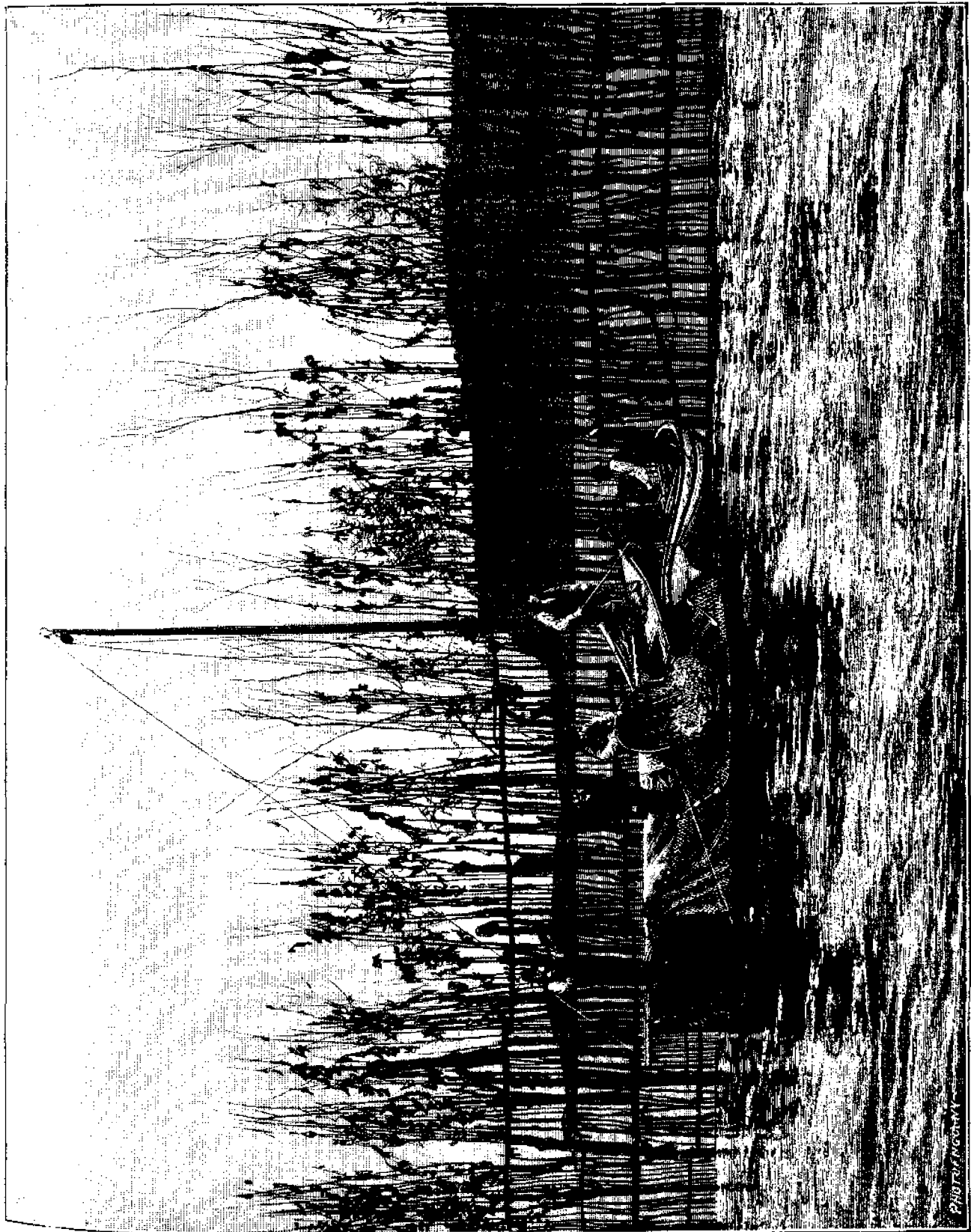

**THE SARDINE INDUSTRY.**

Fishing a herring-weir at low tide, near Eastport, Me. (Sect. v, vol. i, p. 503.)

From a photograph by T. W. Searles.

PHOTOGRAPH BY T. W. SEARLES



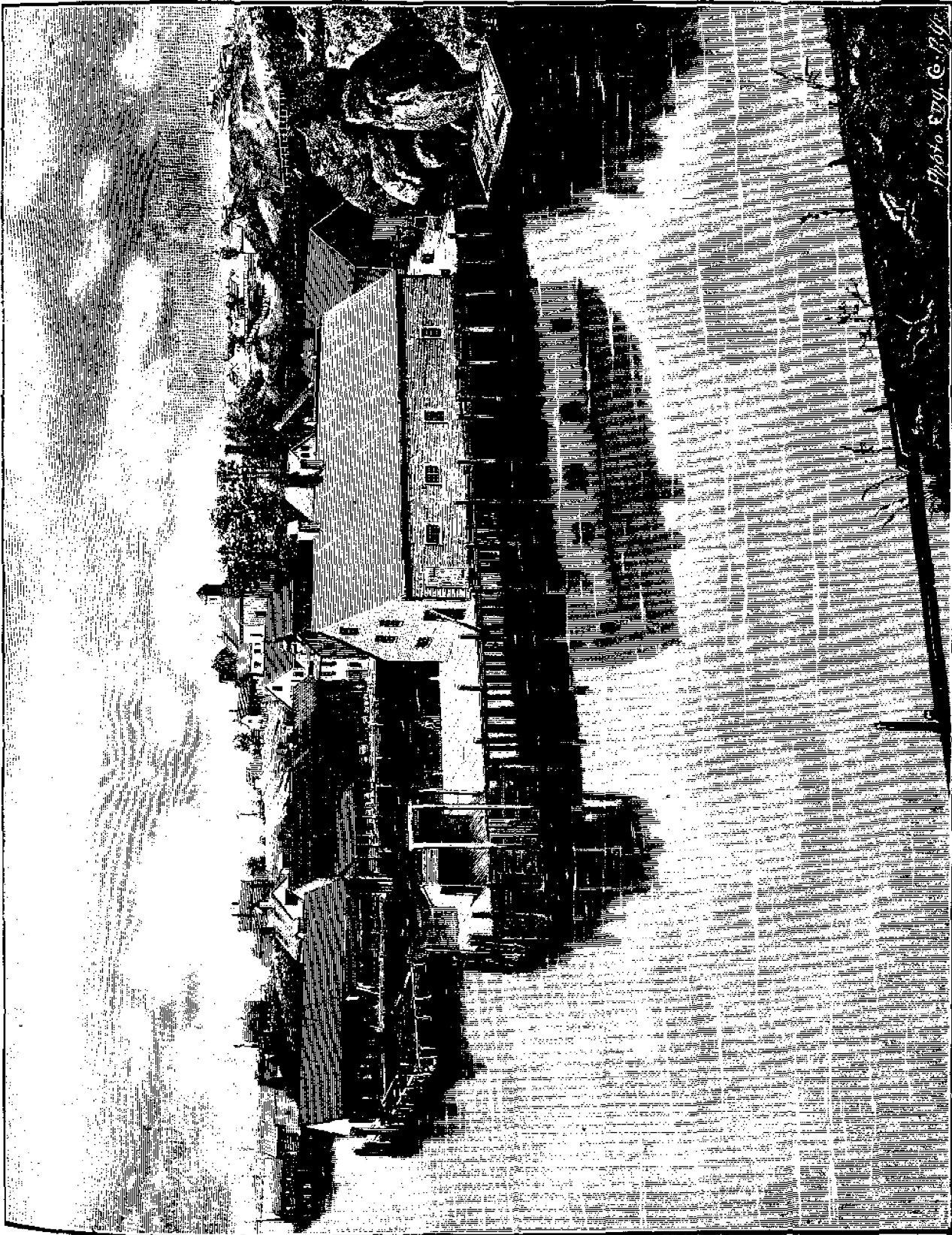

**THE SARDINE INDUSTRY.**

General view of a sardine cannery at Eastport, Me. (Sect. V, vol. 4, p. 505.)

From a photograph by T. W. Stallie.

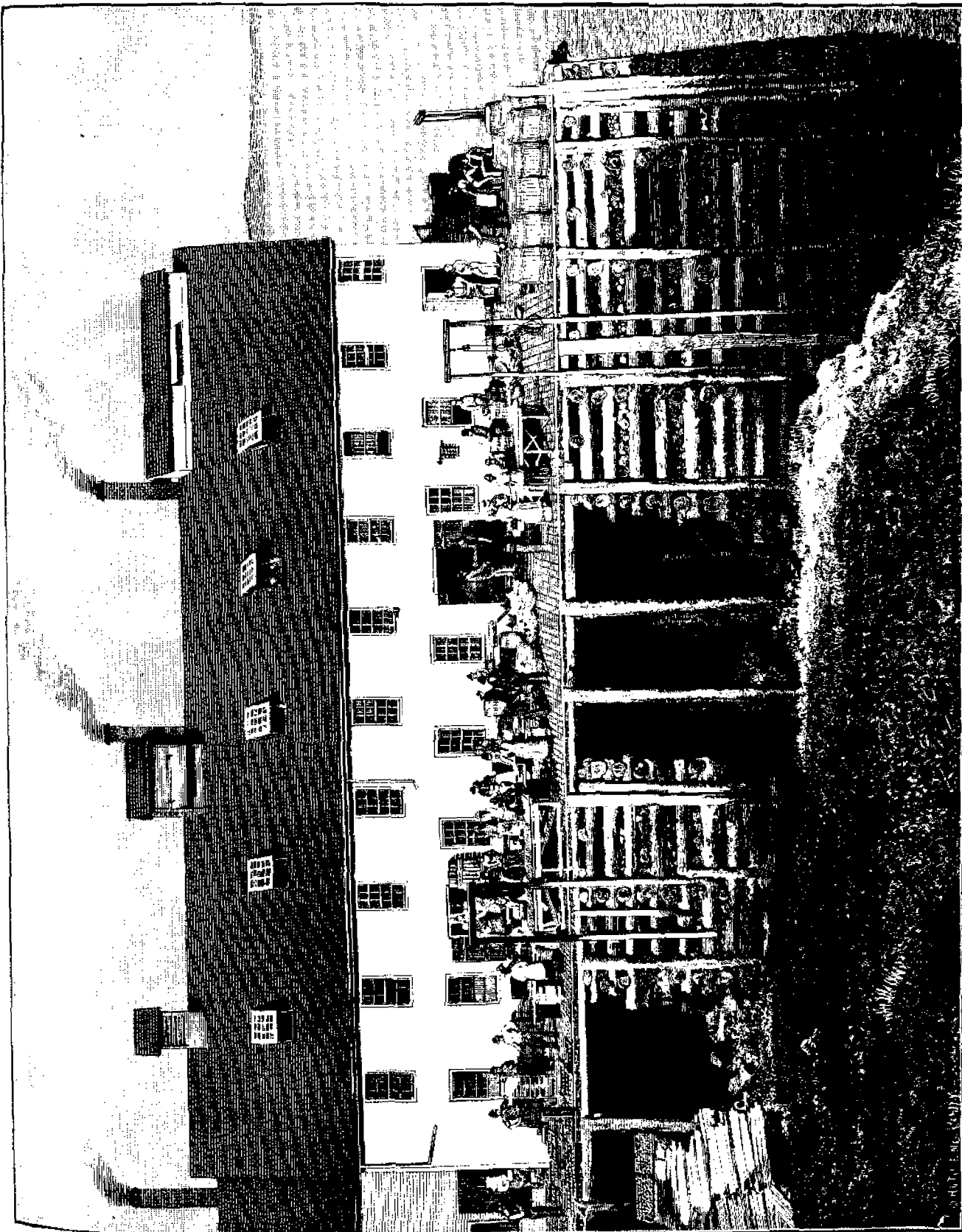

**THE SARDINE INDUSTRY.**

View of a sardine cannery at low tide, showing the employes at work. (Sect. v, vol. i, p. 508.)  
From a photograph by T. W. Smilie.

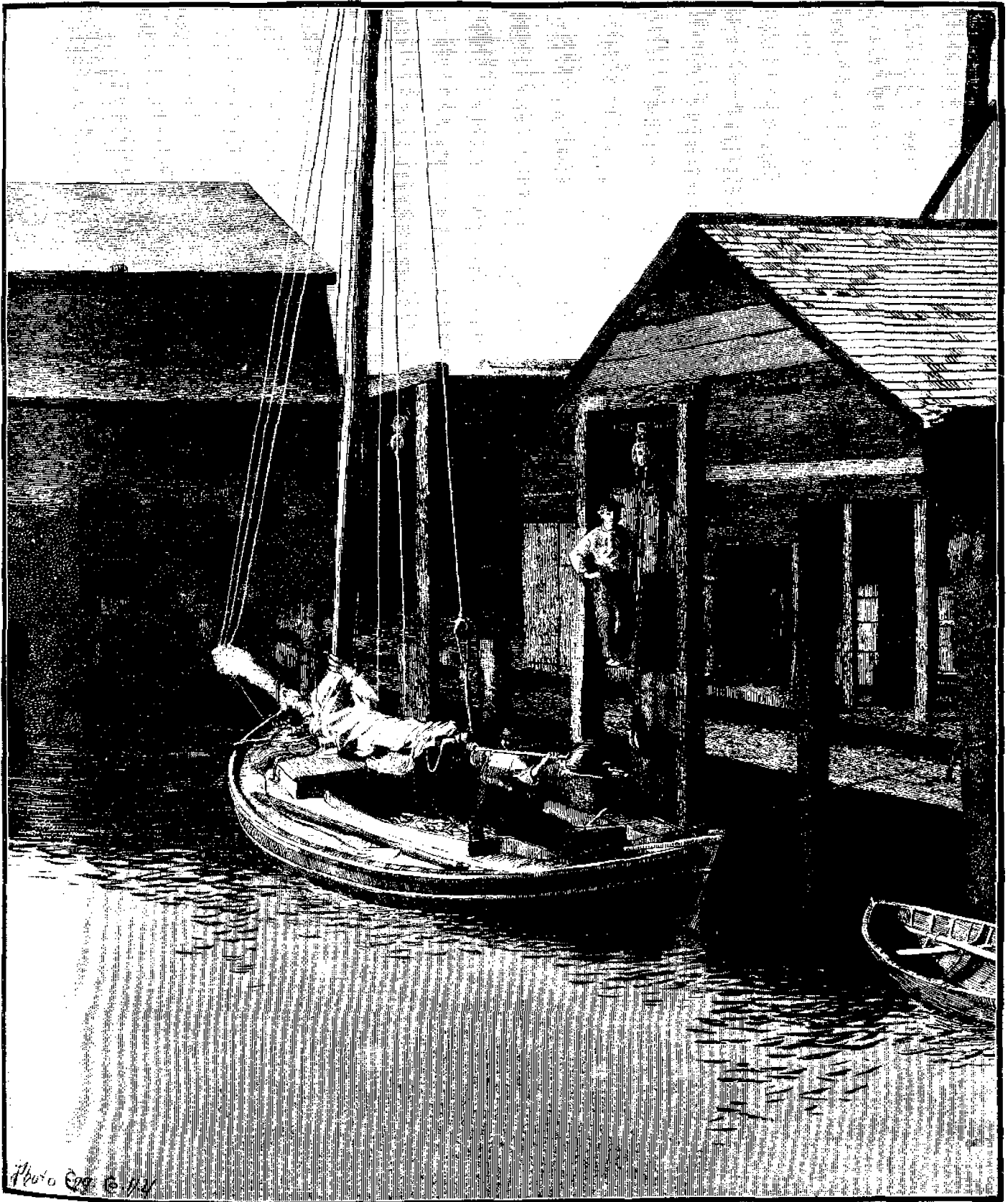

**THE SARDINE INDUSTRY.**

Unloading herring at a sardine cannery, Eastport, Me. (Sect. v, vol. 1, p. 509.)

From a photograph by T. W. Snellie.

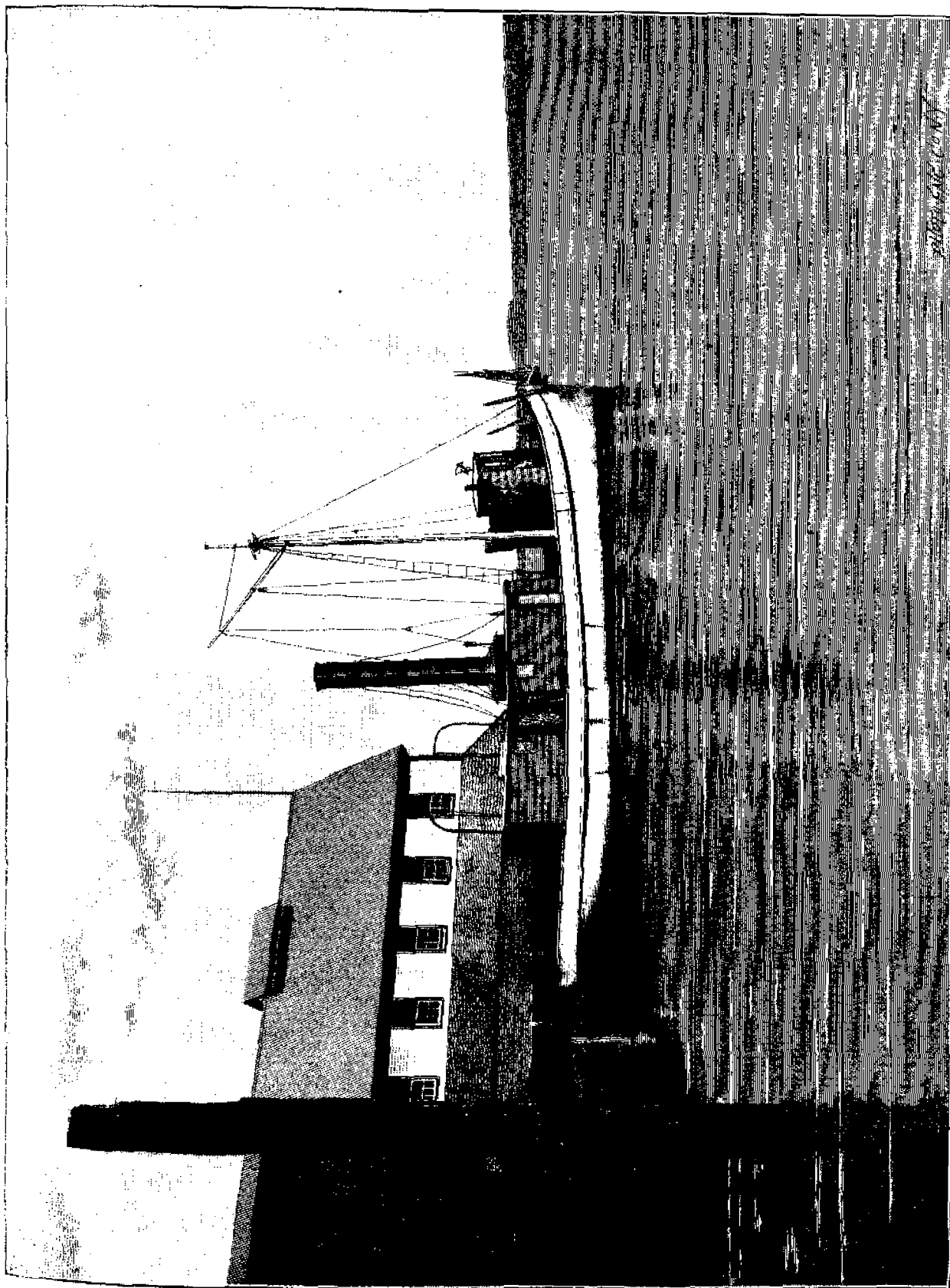

**THE SARDINE INDUSTRY.**

Sardine steamer for collecting herring and towing wear-boats. (Sect. v, vol. i, p. 510.)

From a photograph by T. W. Suttlie.

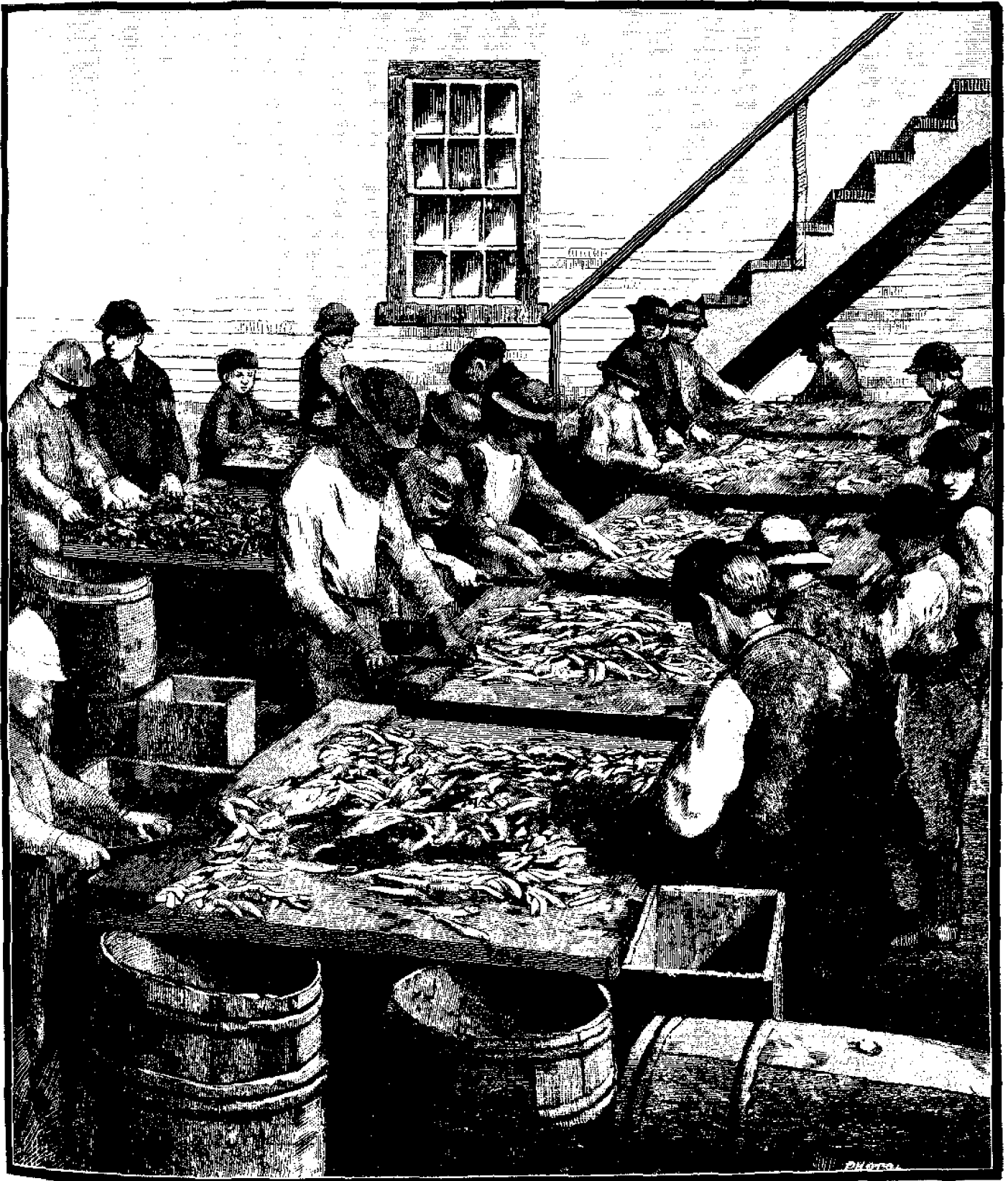

**THE SARDINE INDUSTRY.**

Children at sardine cannery cutting off the heads and tails, and cleaning small herring for canning. (Sect. v, vol. i, p. 510.)

From a photograph by T. W. Smillie.

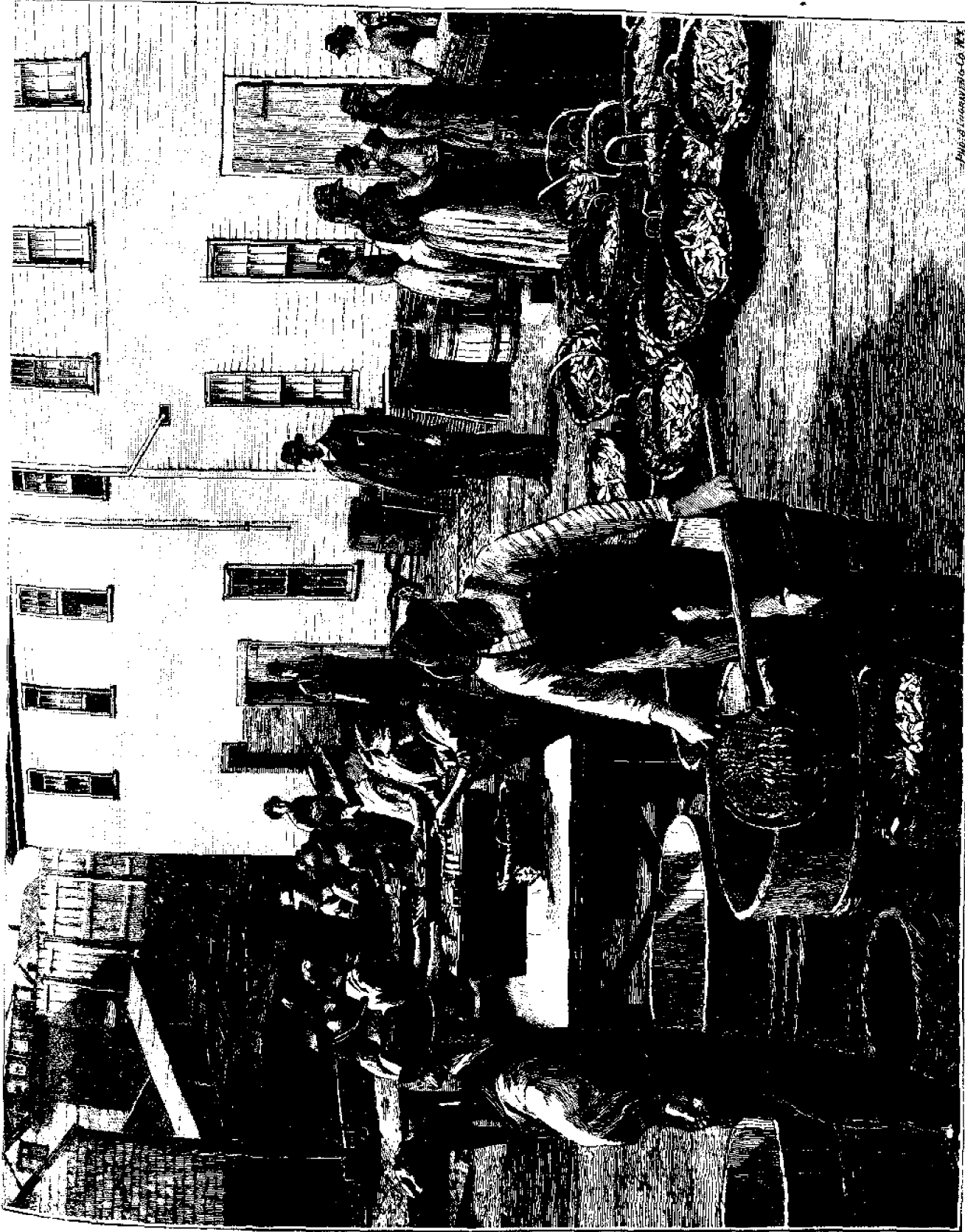

Photo. by Underhill & Co., N.Y.

### THE SARDINE INDUSTRY.

Washing, draining, and tacking herring at sardine cannery, Eastport, Me. (Sect. V, Vol. 4, p. 512.)

From a photograph by T. W. Suttle.



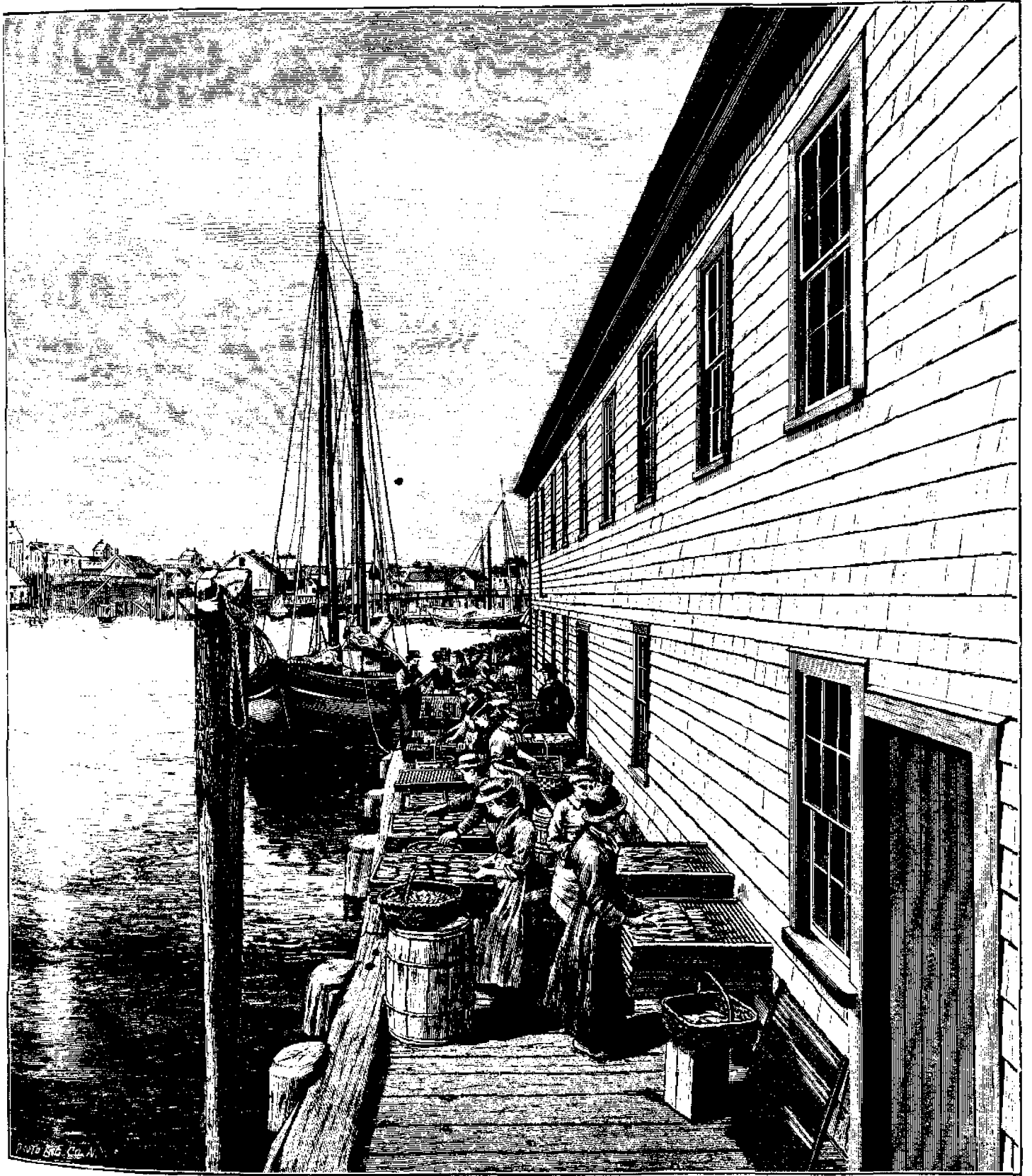

**THE SARDINE INDUSTRY.**

Spreading herring on flakes for drying in the sun or in an oven. (Sect. v, vol. i, p. 511.)

From a photograph by T. W. Stullie.

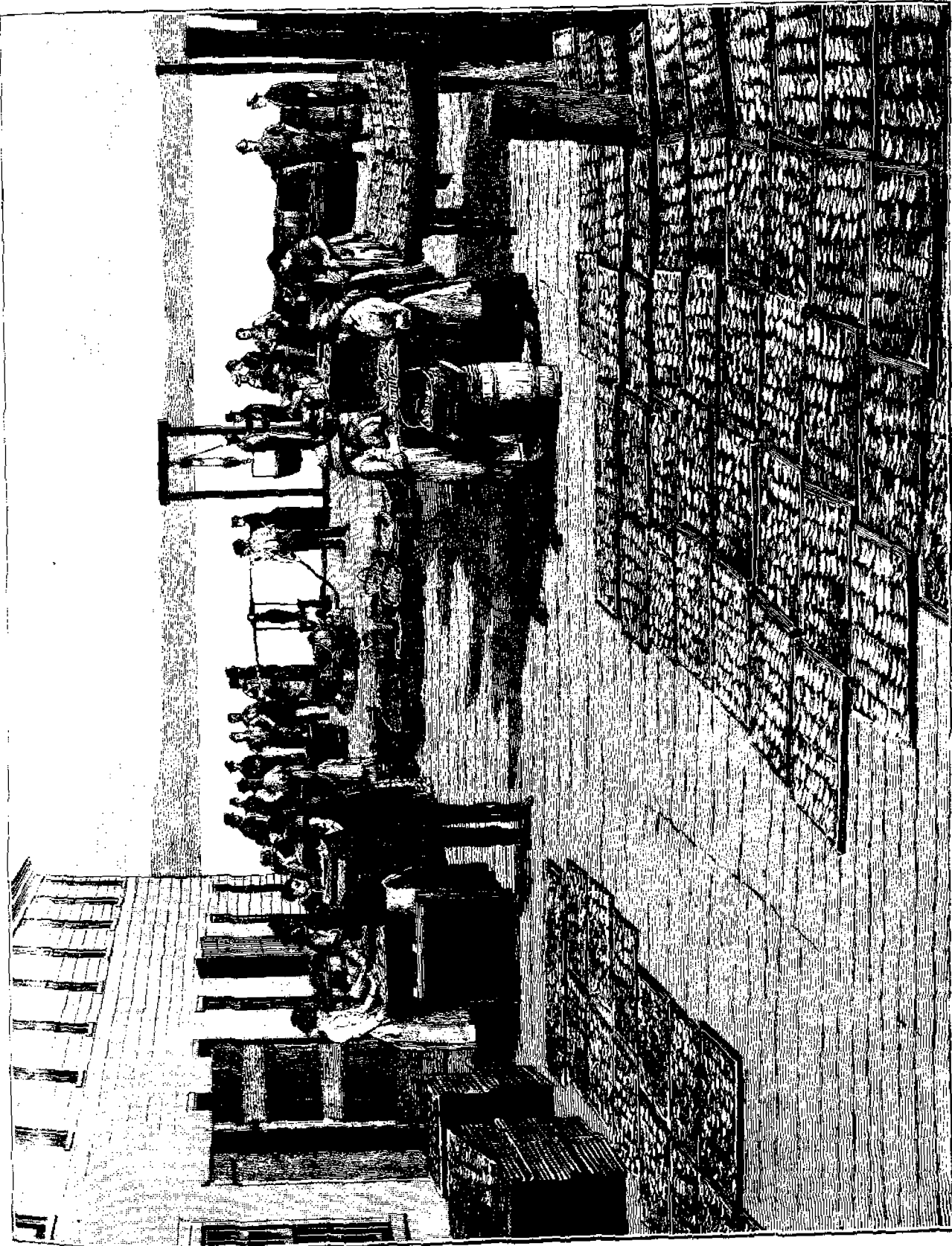

**THE SARDINE INDUSTRY.**

Herring drying on the flakes in the sun; landing, cleaning, washing, &c., at sardine cannery, Eastport, Me. (Sect. V, vol. 1, p. 514.)  
*From a photograph by T. W. Stubble.*



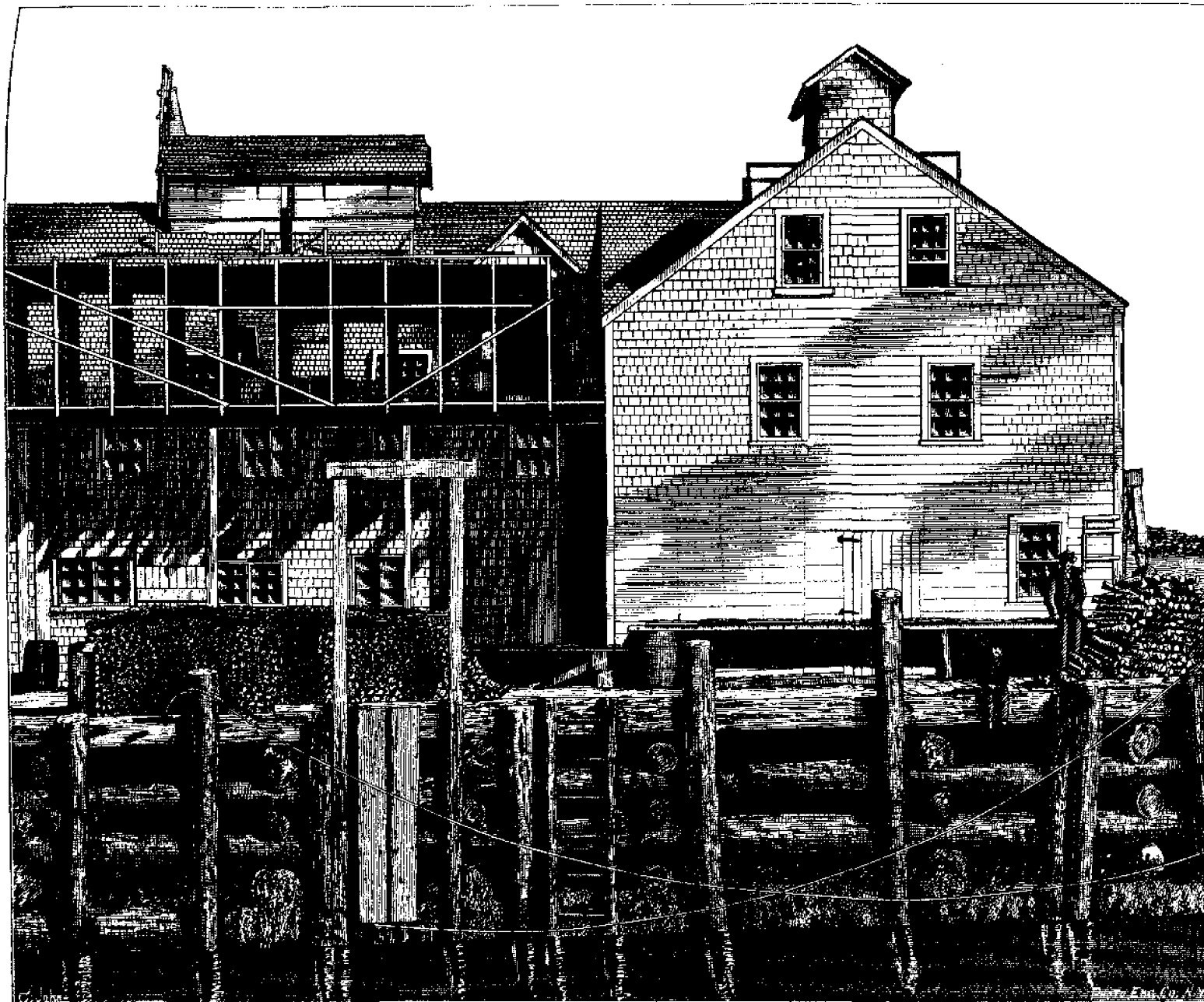

**THE SARDINE INDUSTRY.**

Fish-drying frames on roof of sardine cannery, at Eastport, Me. (Sect. v, vol. i, p. 512.)

From a photograph by T. W. Sullie.

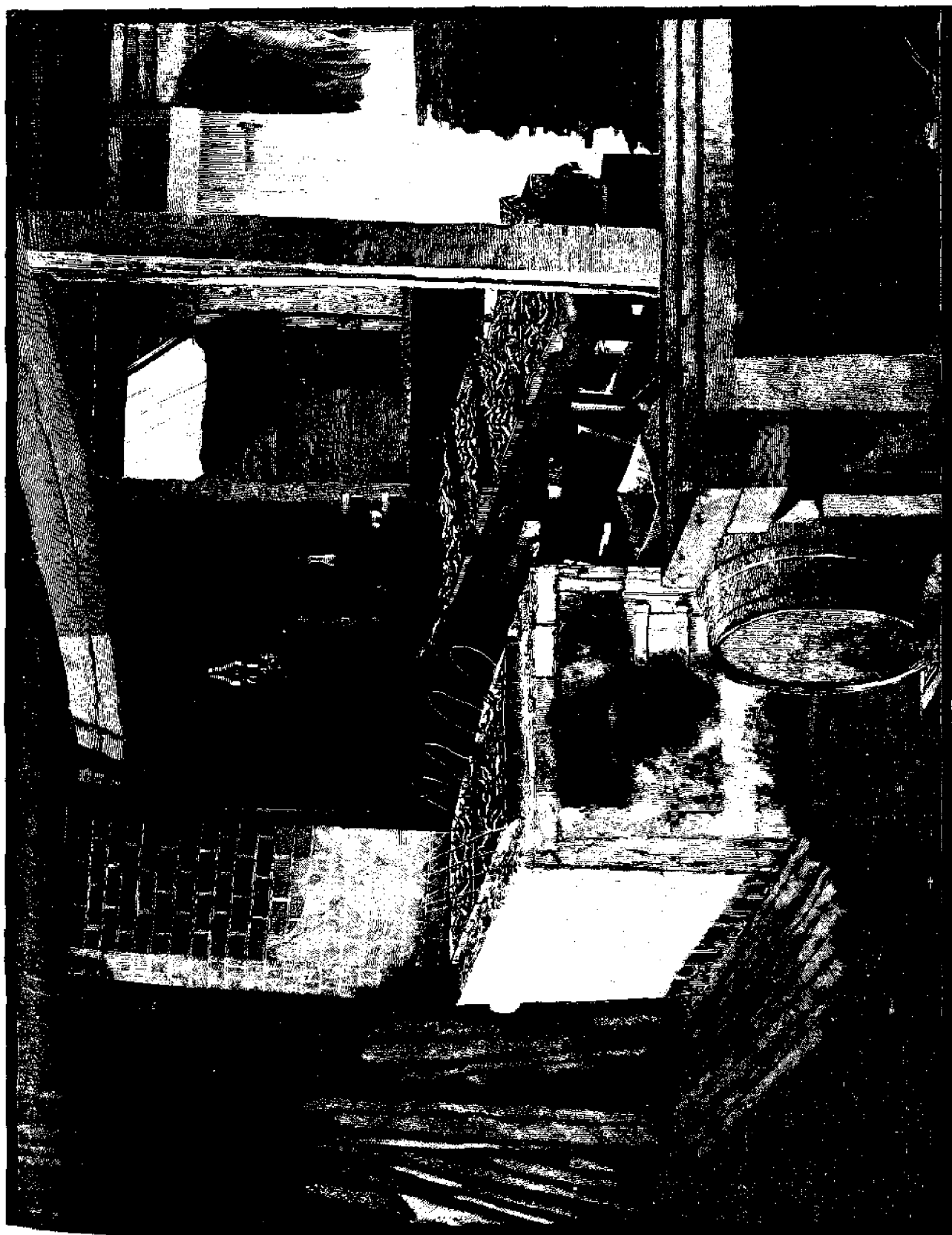

**THE SARDINE INDUSTRY.**

Frying-room in sardine cannery at Eastport, Me.; herring frying in pans of oil. (Sect. v, vol. 4, p. 514.)  
*From a photograph by T. W. Scudler.*



**THE SARDINE INDUSTRY.**

Packing-room in sardine cannery, at Eastport, Me.: packing herring-sardines in tin boxes. (Sect. v, vol. i, p. 515.)

From a photograph by T. W. Smilie.

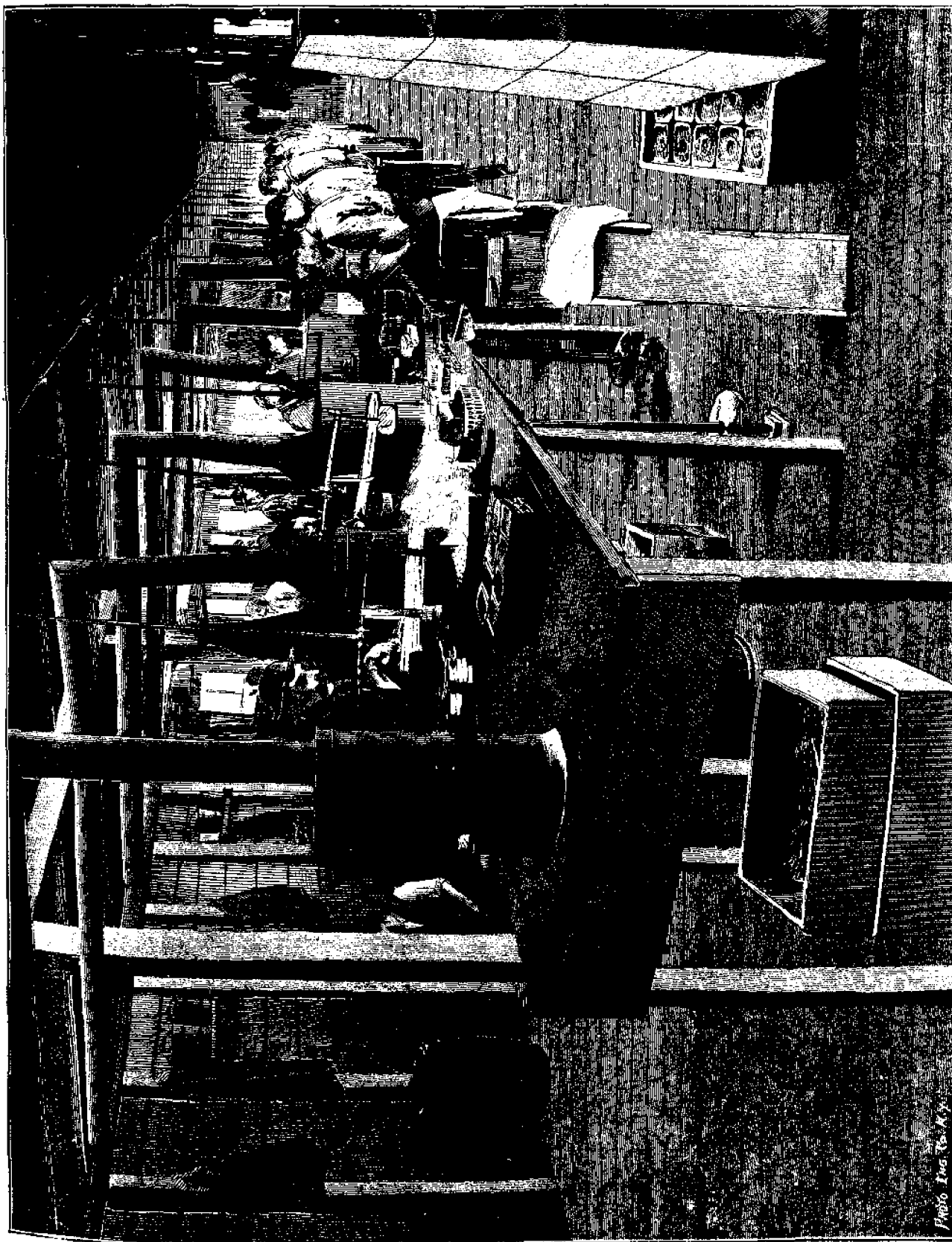

**THE SARDINE INDUSTRY.**

Soldiering room in sardine cannery, Eastport, Me.; soldiers sealing the cans. (Scott, v. vol. 1, p. 516.)  
From a photograph by I. W. Sanfillip.

Photo. Ives, T. & Co.

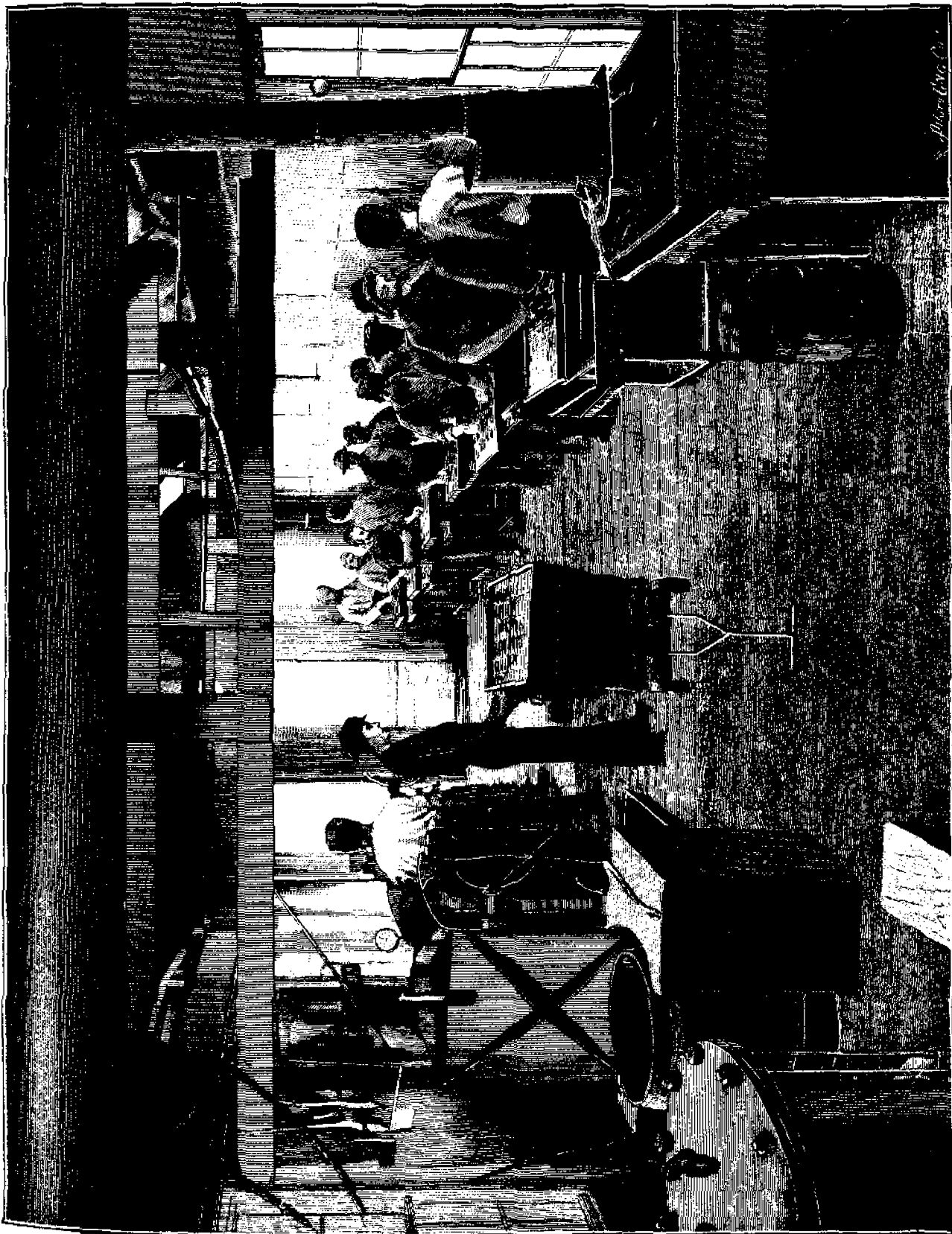

**THE SARDINE INDUSTRY.**

Bathing-room at sardine cannery, Eastport, Me.; bathing-cats at left; men at right venting the cans. (Sect. V, vol. I, p. 517.)

From a photograph by T. W. Smilie.



**THE SARDINE INDUSTRY.**

Making sardine cans at Eastport, Me. (Sect. v, vol. i, p. 51-2)

From a photograph by T. W. Smith.

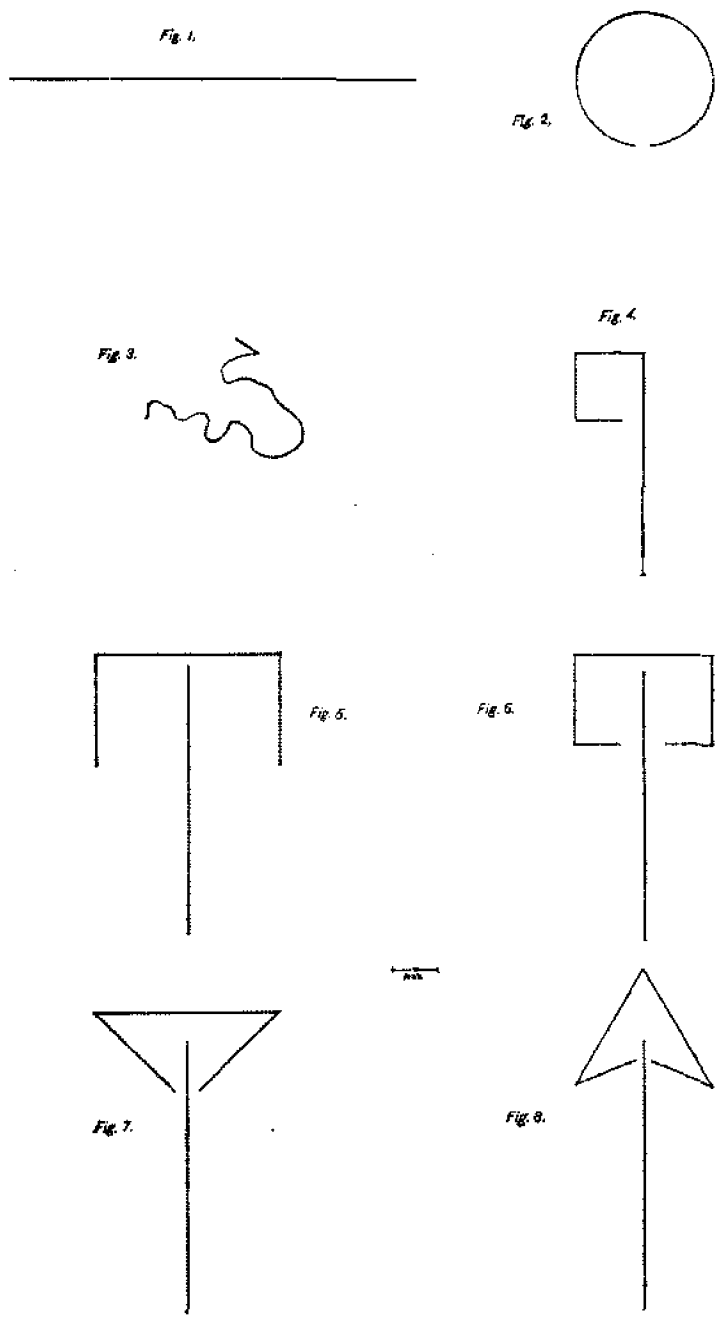

**THE SPANISH MACKEREL FISHERY.**

Methods of setting gill-nets at Sandy Hook. (Sect. v. vol. i, p. 546.)

- |                         |                         |
|-------------------------|-------------------------|
| FIG. 1. "Straight set." | FIG. 5. "T set."        |
| FIG. 2. "Circle set."   | FIG. 6. "Square set."   |
| FIG. 3. "Crooked set."  | FIG. 7. "Triangle set." |
| FIG. 4. "Hook set."     | FIG. 8. "Harpoon set."  |

From Report U. S. Fish Commission, Part VIII, 1880.

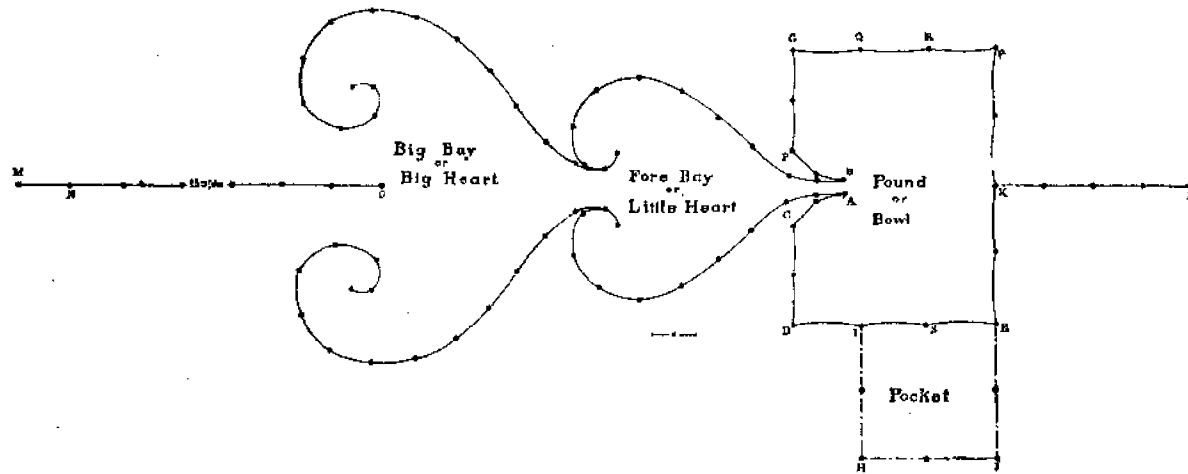

**THE SPANISH MACKEREL FISHERY.**

Chesapeake Bay pound-net. (Sect. v, vol. i, pp. 548, 549.)

(Letters refer to method of fishing the net, described on page 549 of text.)





THE MULLET FISHERY.

Camp of mullet fishermen, North Carolina. (Sect. v, vol. i, p. 562.)

From a photograph.

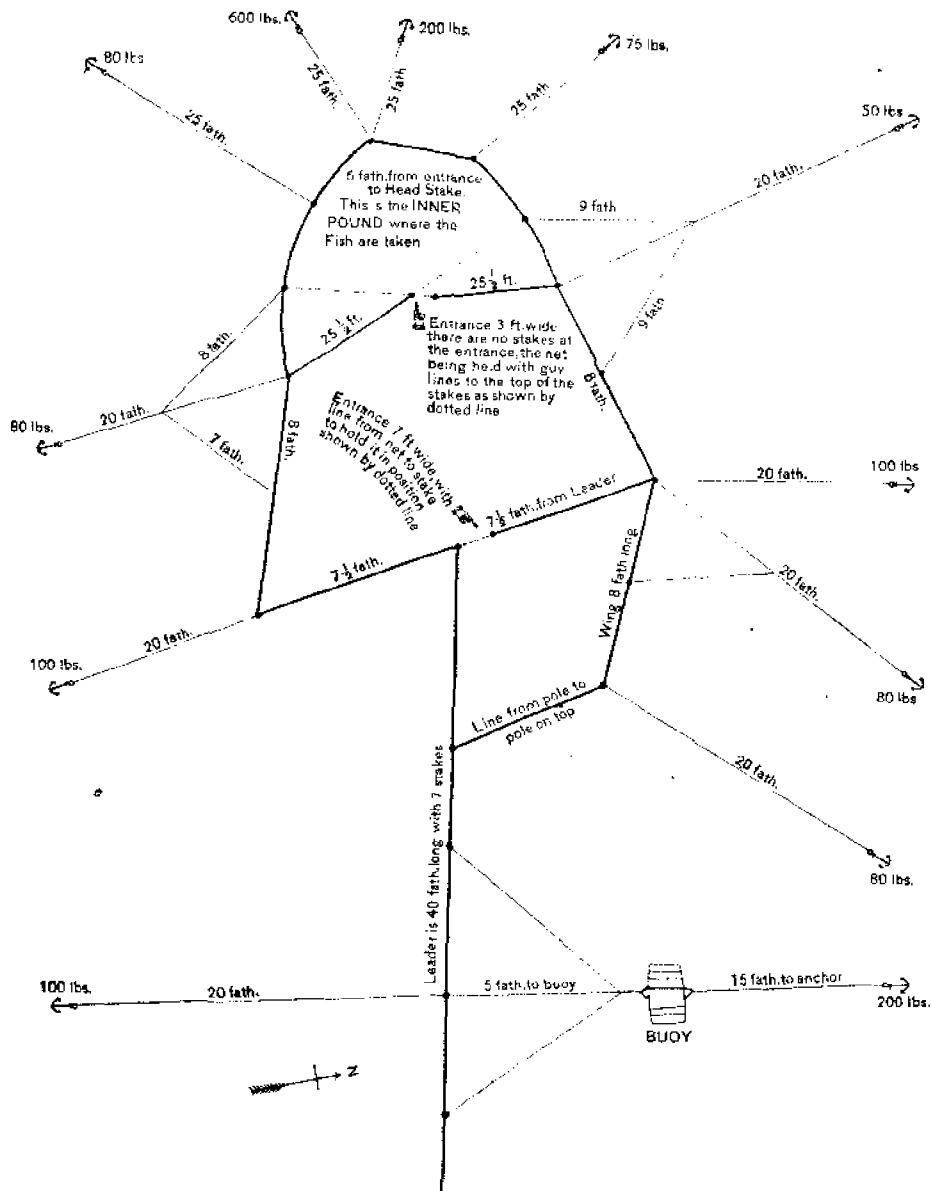

THE POUND-NET FISHERIES OF THE ATLANTIC STATES.

Pound-net at Bald Head, Me. (Sect. v, vol. i, p. 598.)

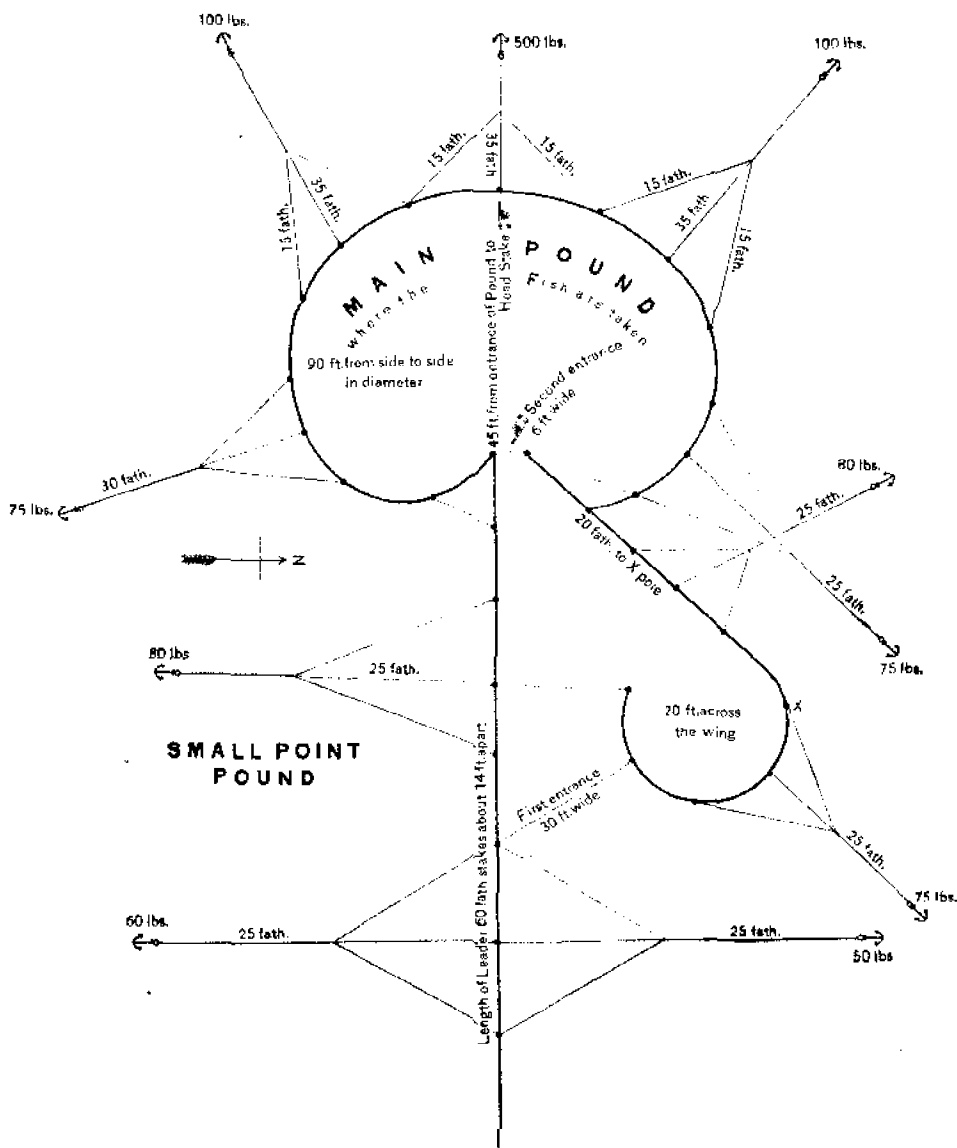

**THE POUND-NET FISHERIES OF THE ATLANTIC STATES.**

Pound-net at Small Point, Me. (Sect. v, vol. i, p. 508.)



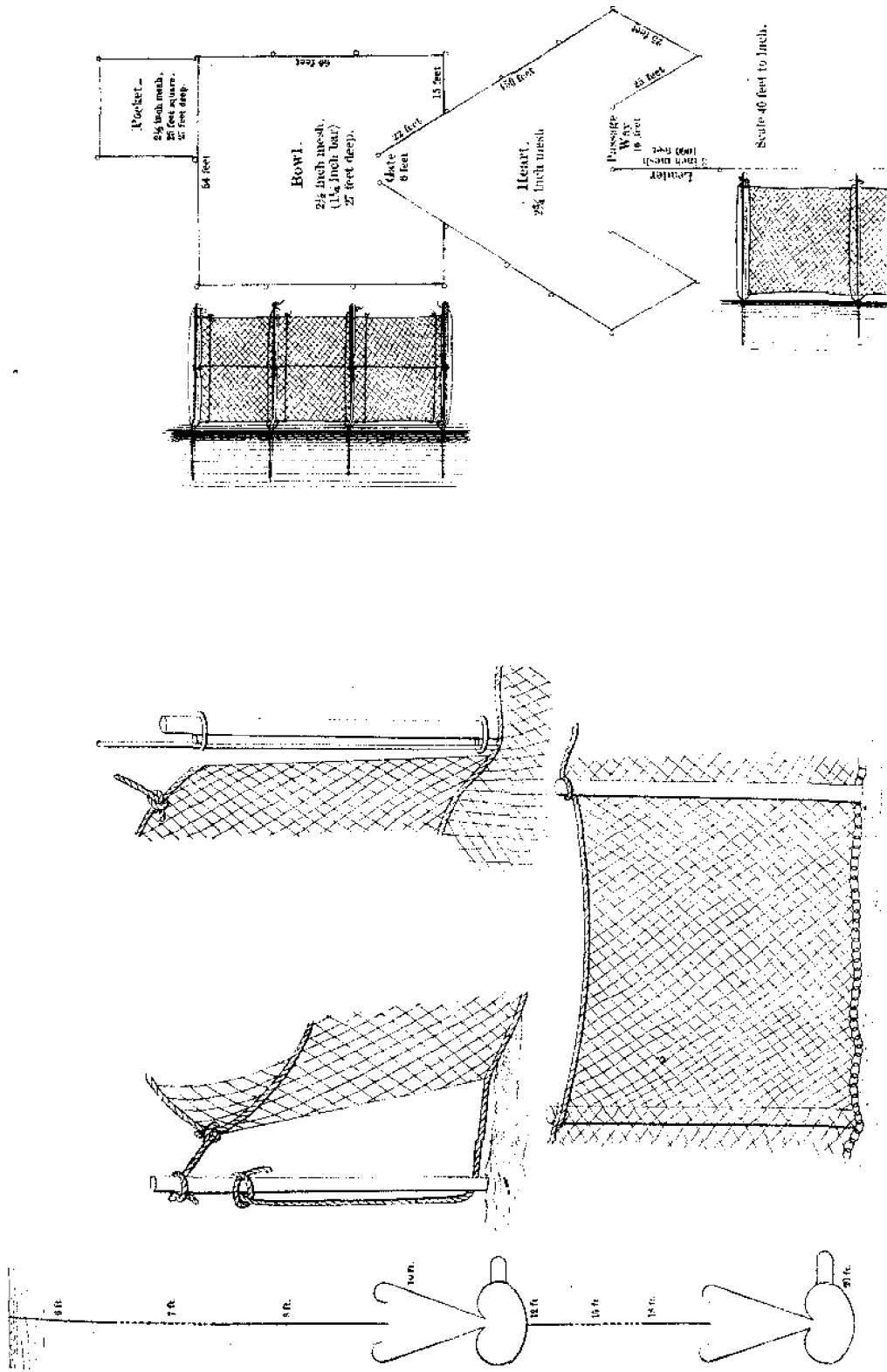
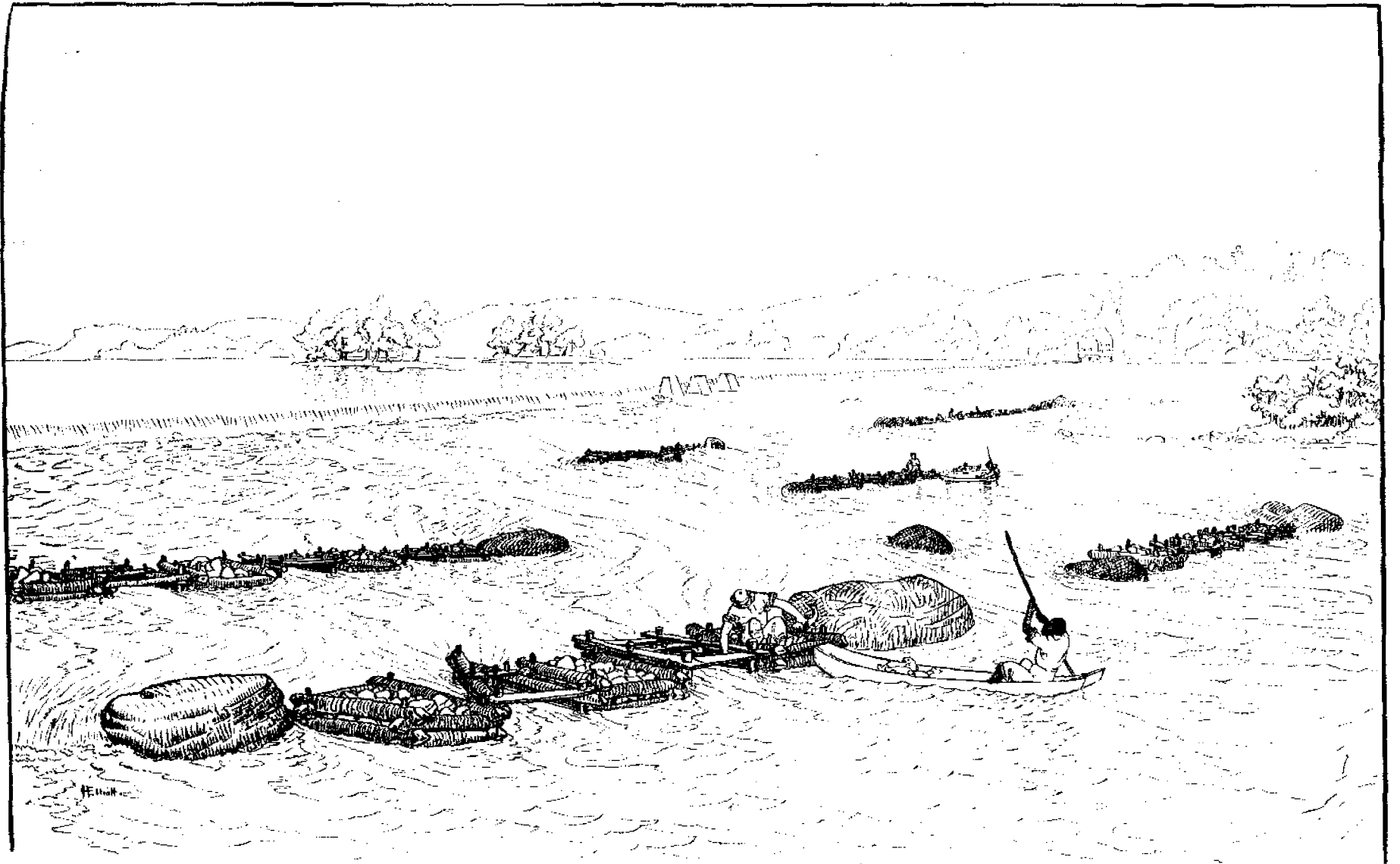

Fig. 2.—Heart or pound net at Quisset Har bor, Massachusetts.

THE POUND-NET FISHERIES OF THE ATLANTIC STATES.

(Sect. V, vol. I, p. 601.)  
 From Report U. S. Fish Commission, Part I, 1872-73.

Fig. 1.—Pound-net at Weymouth, Mass.



**THE RIVER FISHERIES OF THE ATLANTIC STATES.**

Fishing with back and square traps in the Savannah River. (Sect. v, vol. i, p. 620.)

Drawing by H. W. Elliott.

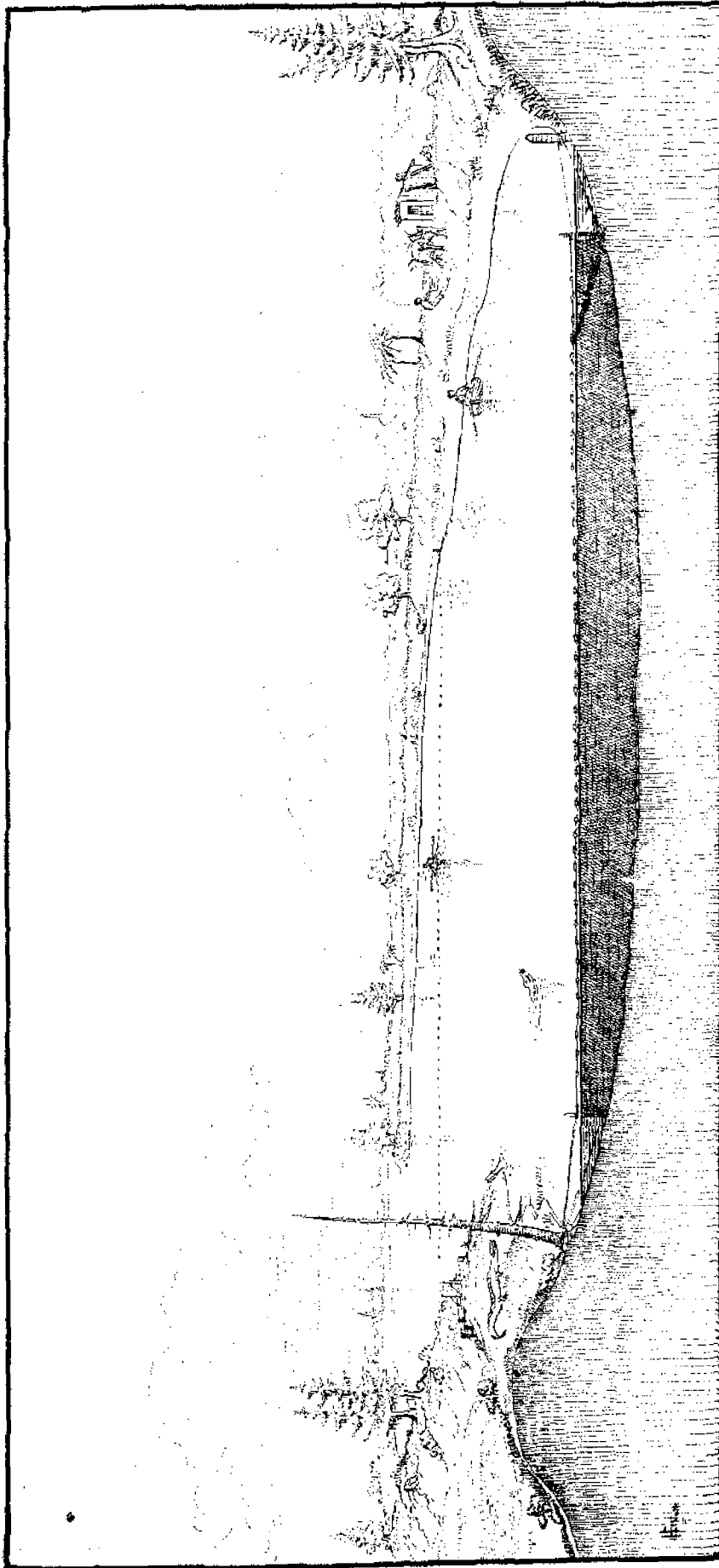

**THE RIVER FISHERIES OF THE ATLANTIC STATES.**

Shad gill-nets in the Edisto River, South Carolina. (Sect. V, vol. 1, p. 623.)

Drawing by H. W. Ellner.

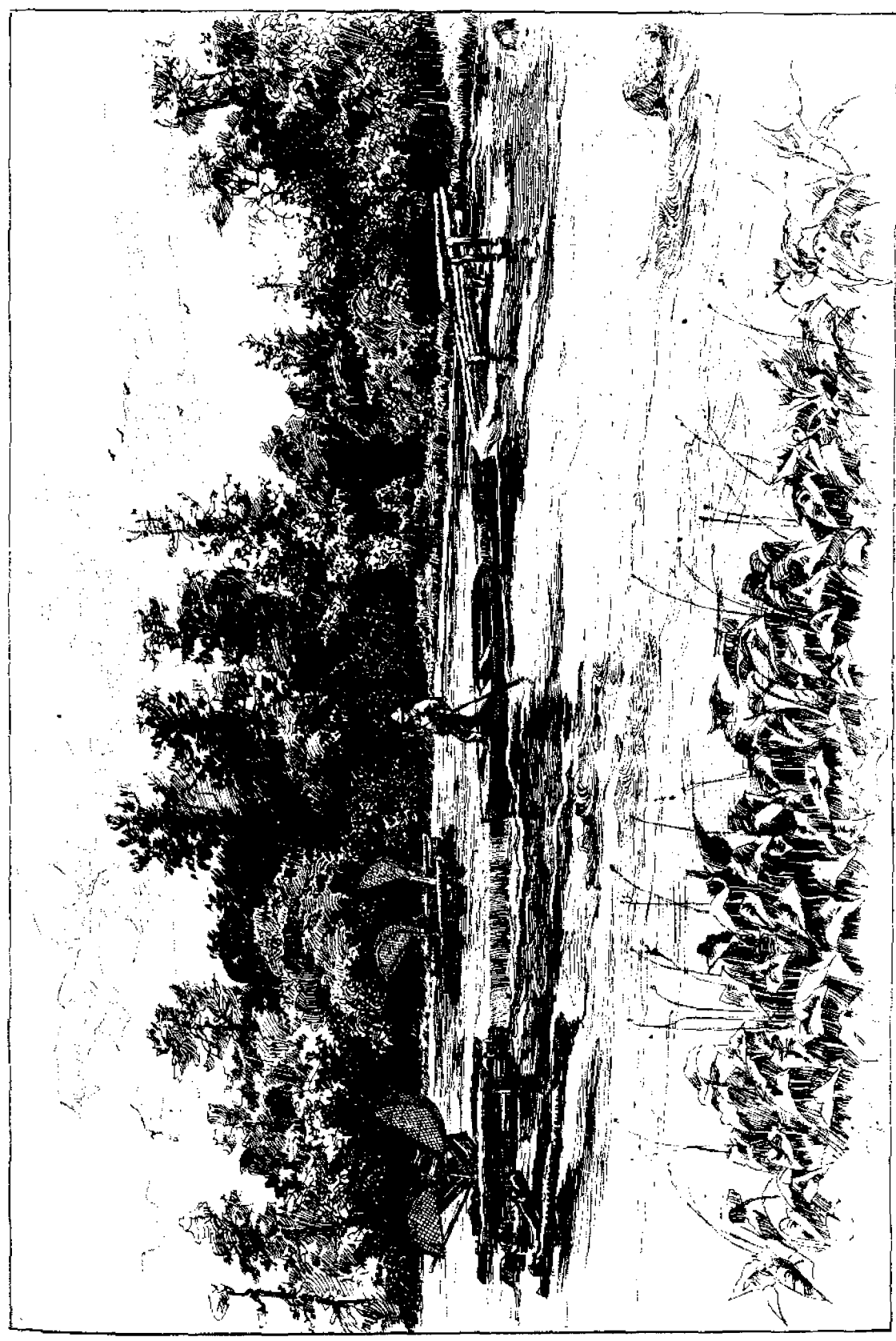

THE RIVER FISHERIES OF THE ATLANTIC STATES.

Fish-acts in the Peelee River. (Sect. 8, vol. 1, p. 624.)

From a photograph.



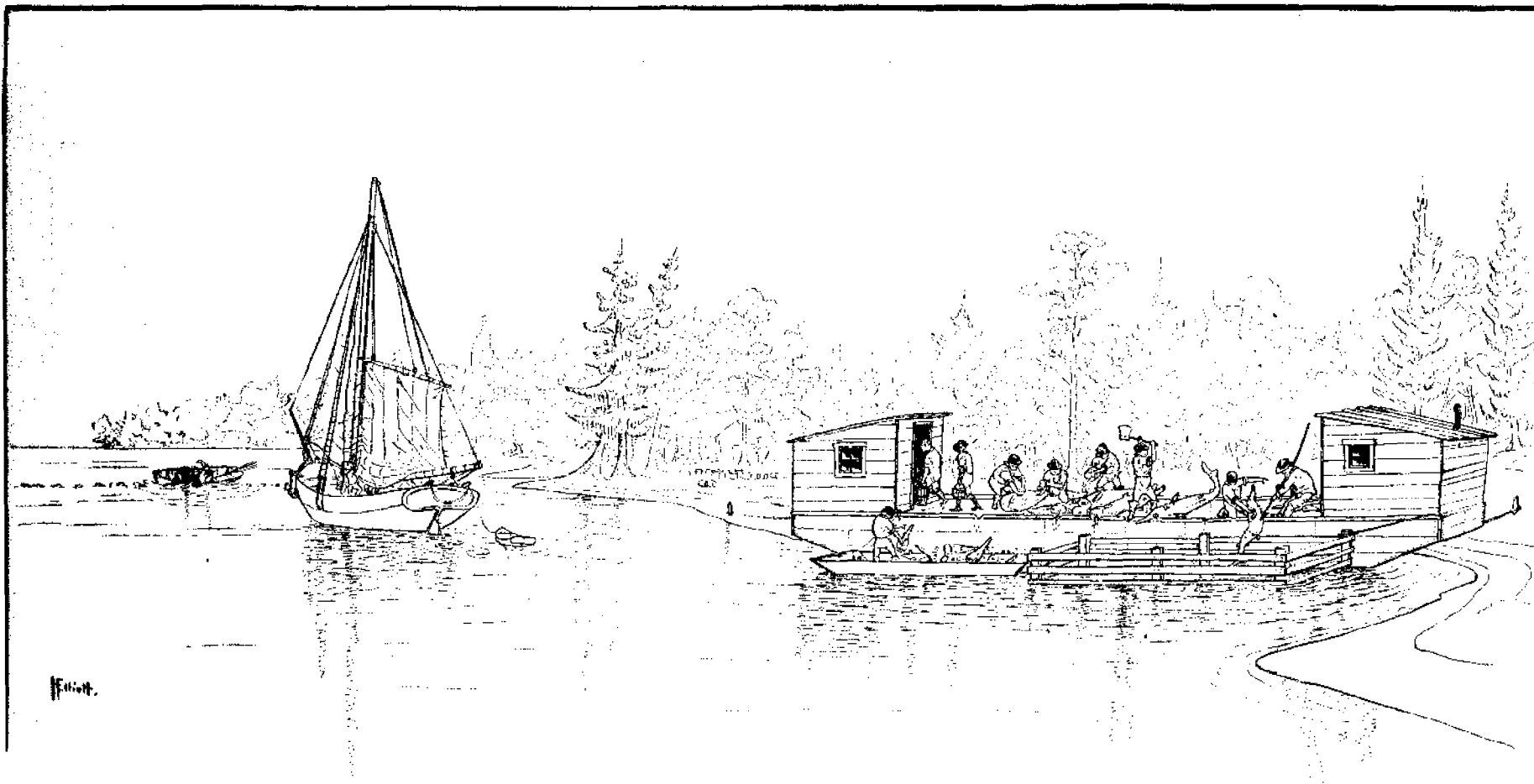

**THE RIVER FISHERIES OF THE ATLANTIC STATES.**

A sturgeon camp on Winyah Bay, South Carolina: catching sturgeon in gill-nets: the pound for keeping them alive; muleheading; saving caviare. (Sect. v, vol. 1, p. 625.)

Drawing by H. W. Elliott.

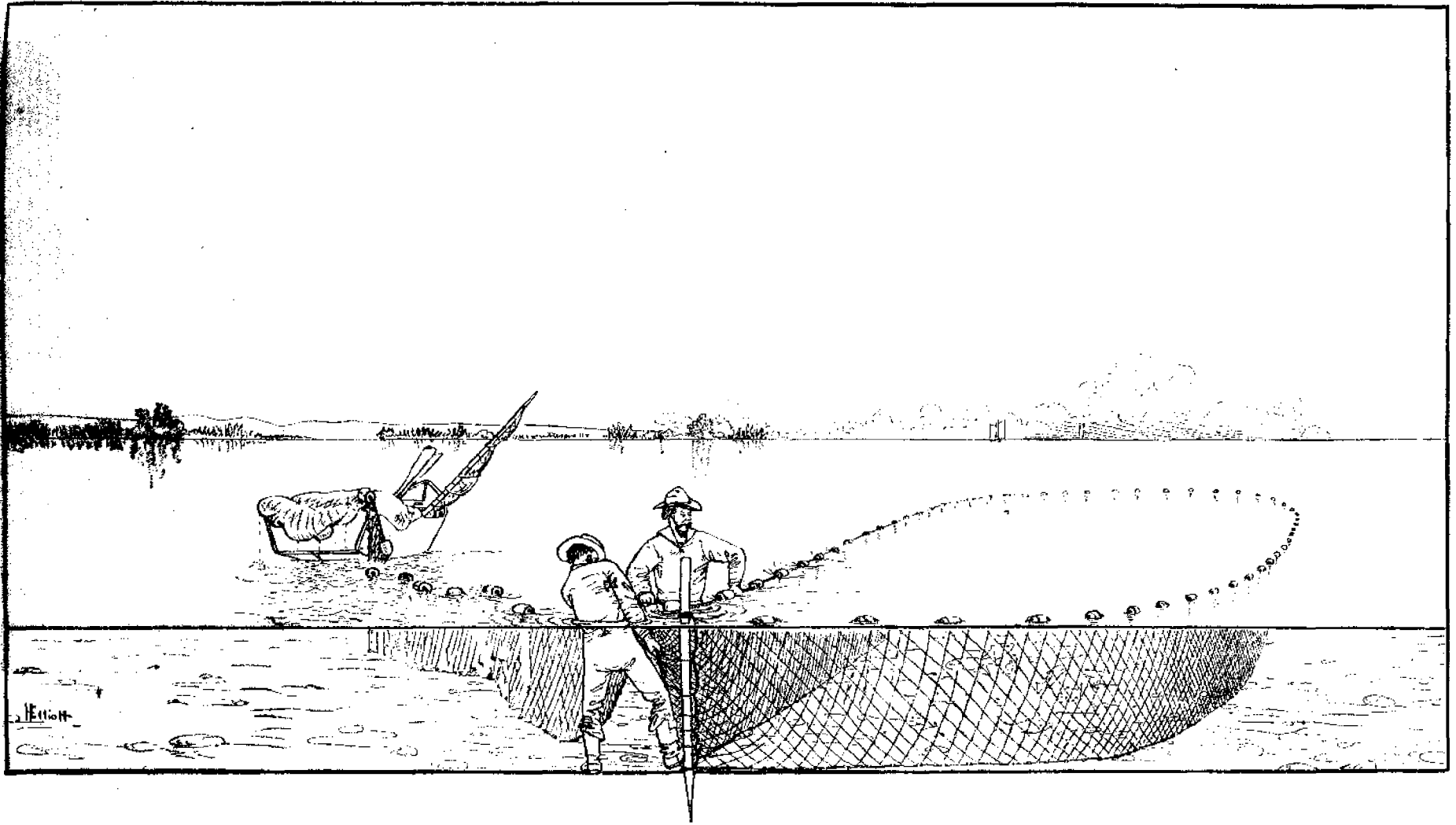

**THE RIVER FISHERIES OF THE ATLANTIC STATES.**

Drag-net fishing in Neuse River, North Carolina: footing-up the net. (Sect. v, vol. 1, p. 628.)

Drawing by H. W. Elliott.

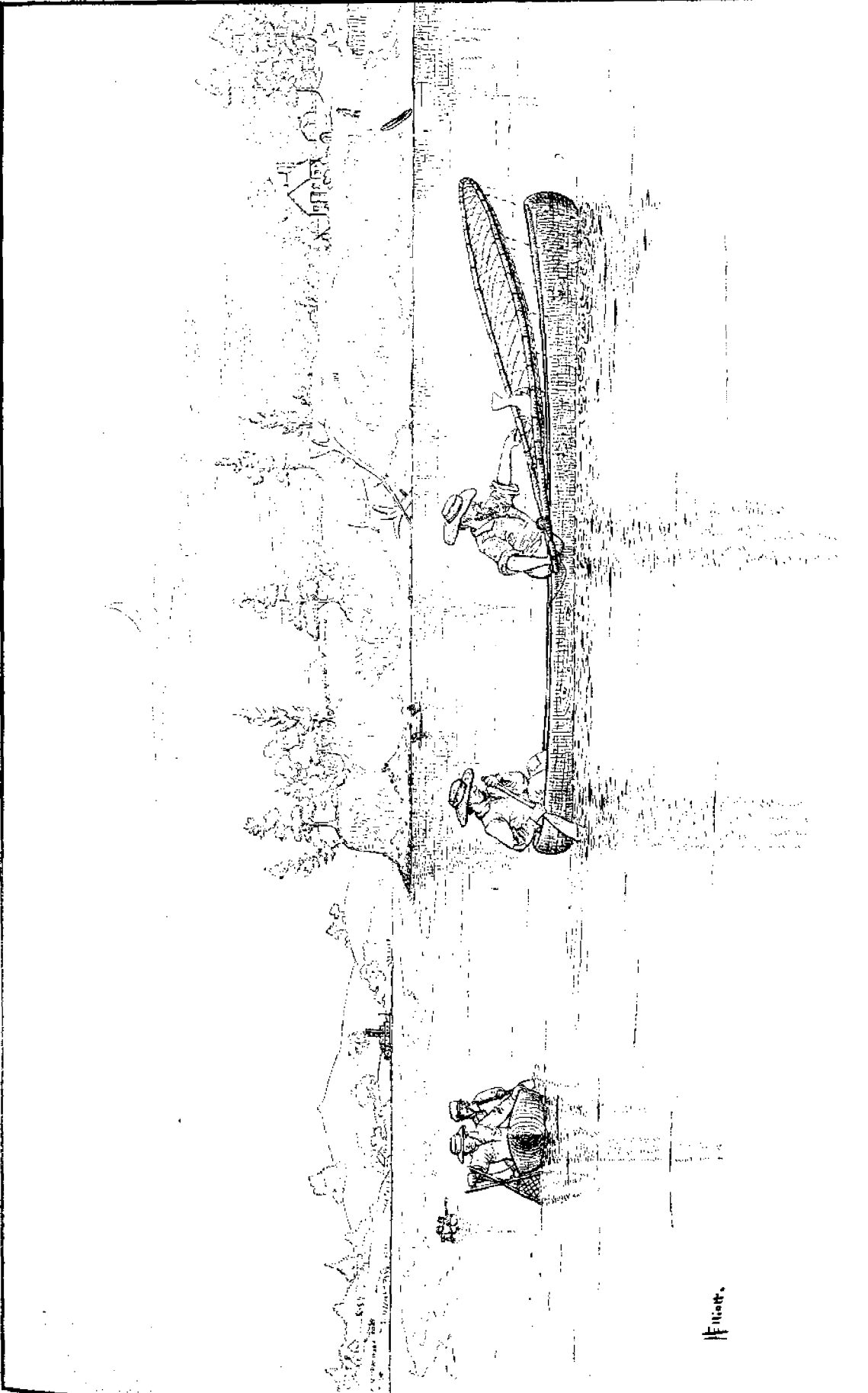

**THE RIVER FISHERIES OF THE ATLANTIC STATES.**

Skim-net fishing for shad in the Neuse River, North Carolina. (Sect. v, vol. i, p. 629.)

Drawing by H. W. Elliott.

Fishes.

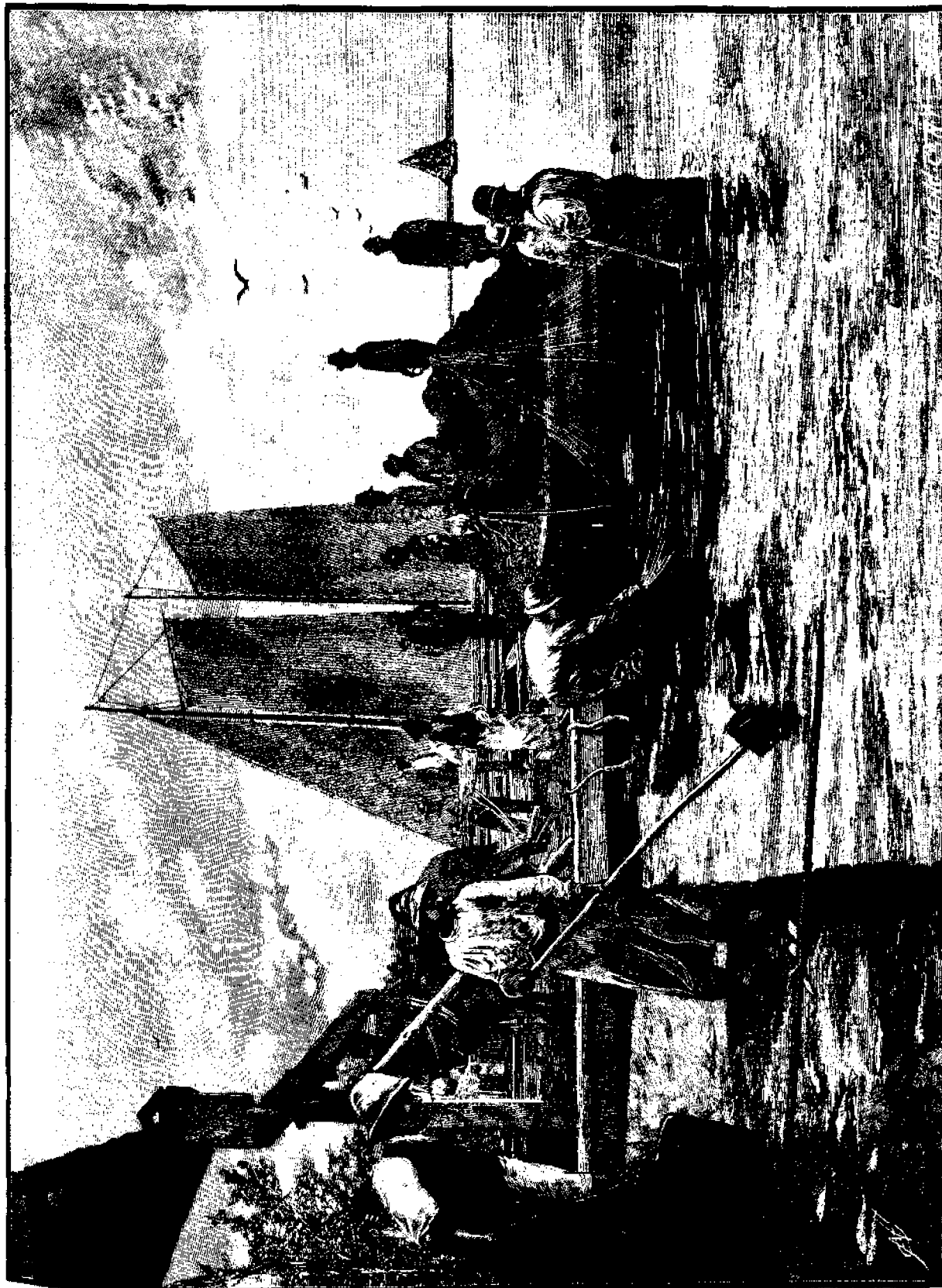

THE RIVER FISHERIES OF THE ATLANTIC STATES.

Hand-seine fishing at Satton Beach, Albermarle Sound, North Carolina: hauling the seine. (See t. v. vol. i, p. 638.)

From a photograph.



THE RIVER FISHERIES OF THE ATLANTIC STATES.

Haul-seine fishing at Sutton Beach, Albemarle Sound, North Carolina: a large haul of alewives. (Seef. v. vol. i. p. 630.)

From a photograph.

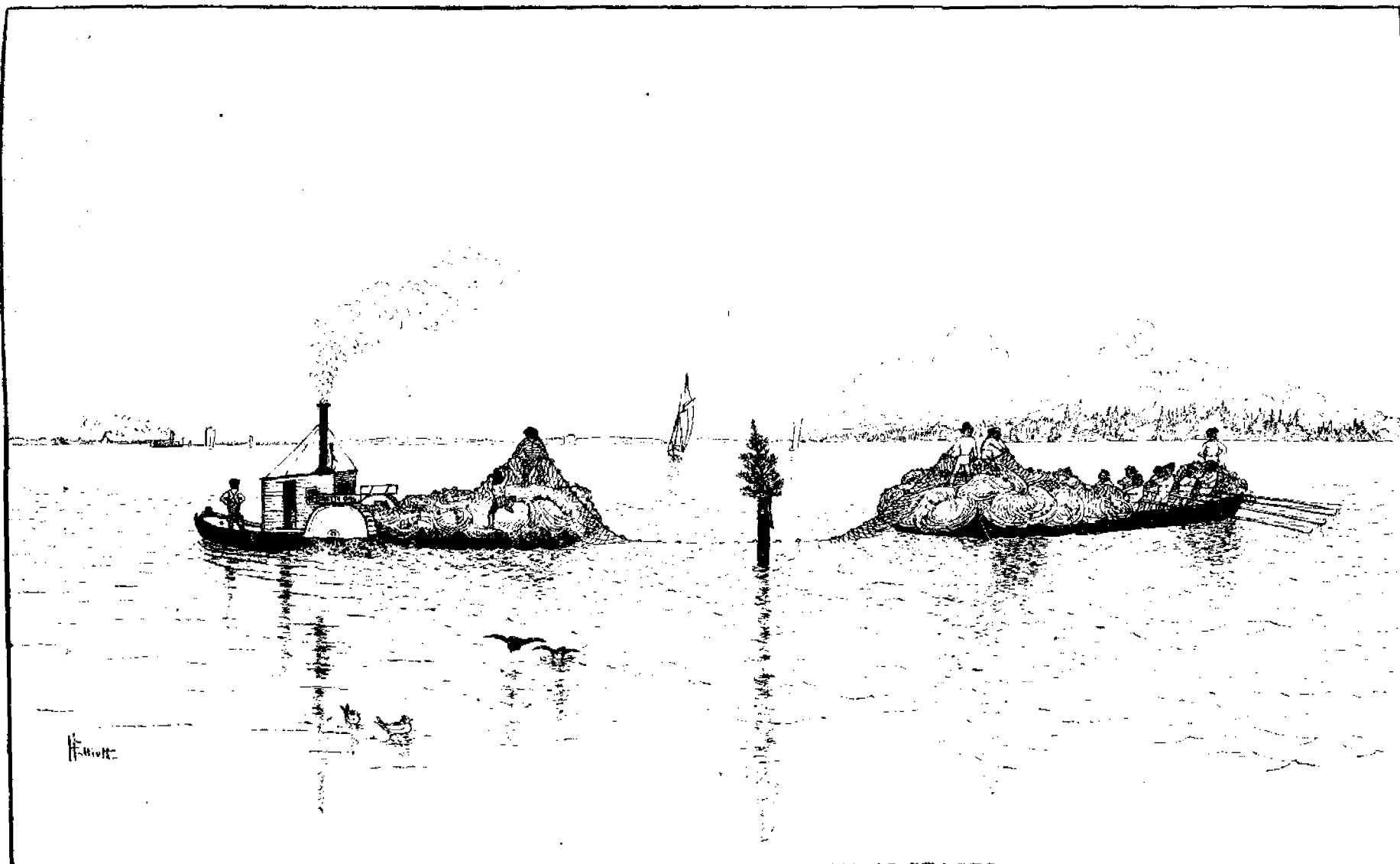

**THE RIVER FISHERIES OF THE ATLANTIC STATES.**

Shad fishing in Albemarle Sound: laying out the seine. (Sect. v, vol. i, p. 636.)

Drawing by H. W. Elliott.

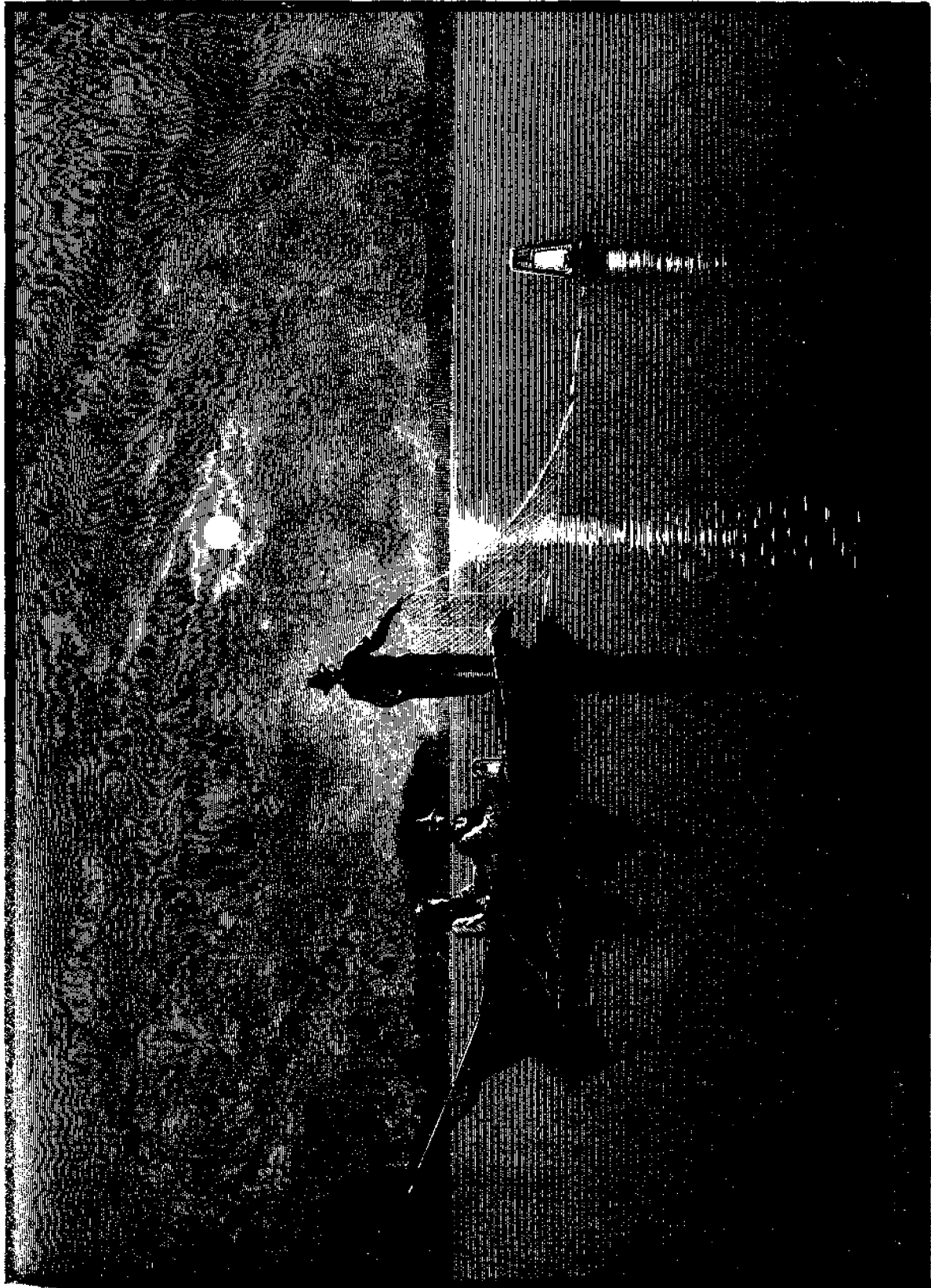

**THE RIVER FISHERIES OF THE ATLANTIC STATES.**

Shad fishing at night on the Susquehanna River; laying out the gill-net. (Seet., v, vol. I, p. 652.)

From a photograph.

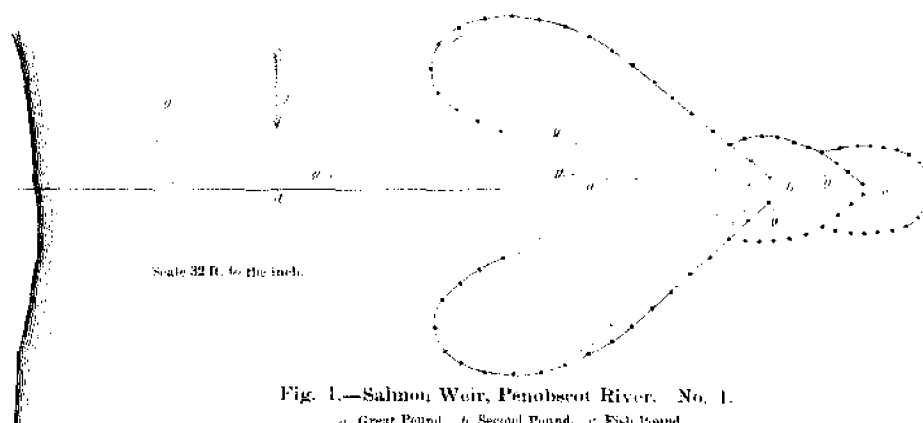

Fig. 1.—Salmon Weir, Penobscot River, No. 1.

a. Great Pond. b. Second Pond. c. Fish Pond.  
 d. Leader. e. Shore. f. Direction of Current.  
 g. Course of Fish.

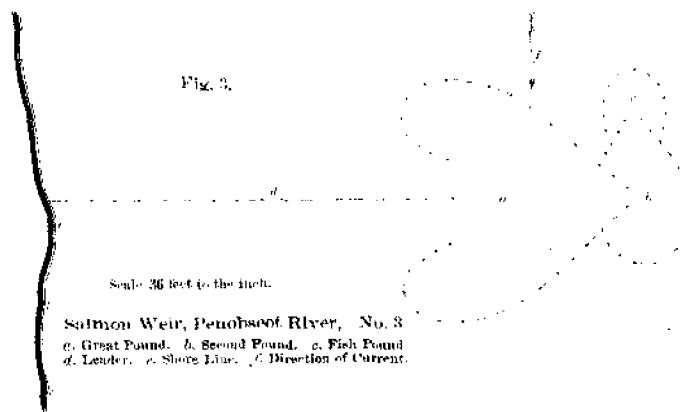

Fig. 3.

Salmon Weir, Penobscot River, No. 3

a. Great Pond. b. Second Pond. c. Fish Pond.  
 d. Leader. e. Shore Line. f. Direction of Current.

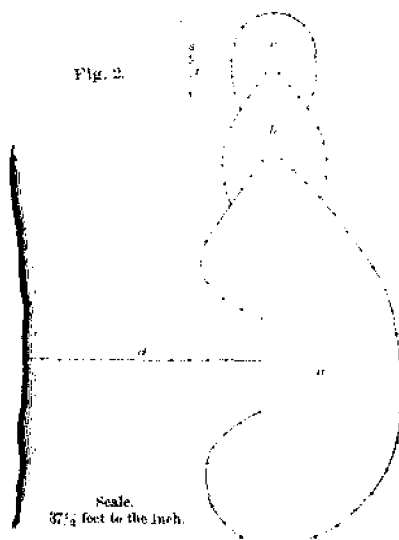

Fig. 2.

Salmon Weir, Penobscot River, No. 2

a. Great Pond. b. Second Pond. c. Fish Pond.  
 d. Leader. e. Shore. f. Direction of Current.

**THE RIVER FISHERIES OF MAINE.**

(Secf. v, vol. i, p. 680.)

From Report U. S. Fish Commission, Part II, 1872-'73.



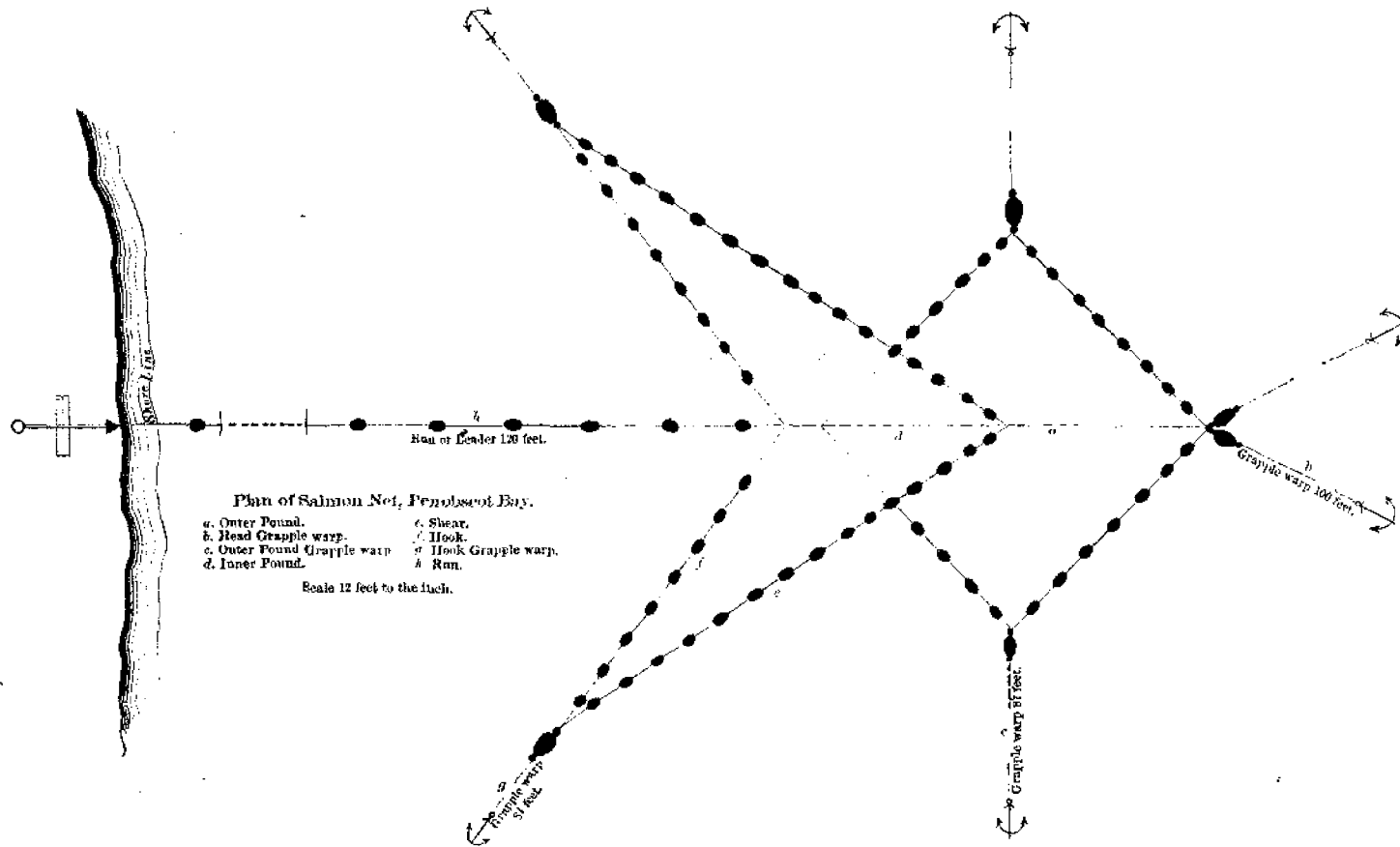

**THE RIVER FISHERIES OF MAINE.**

Plan of salmon-net in Penobscot Bay, Maine. (Sect. v, vol. i, p. 682 ;

From Report U. S. Fish Commission, Part II, 1872-73.

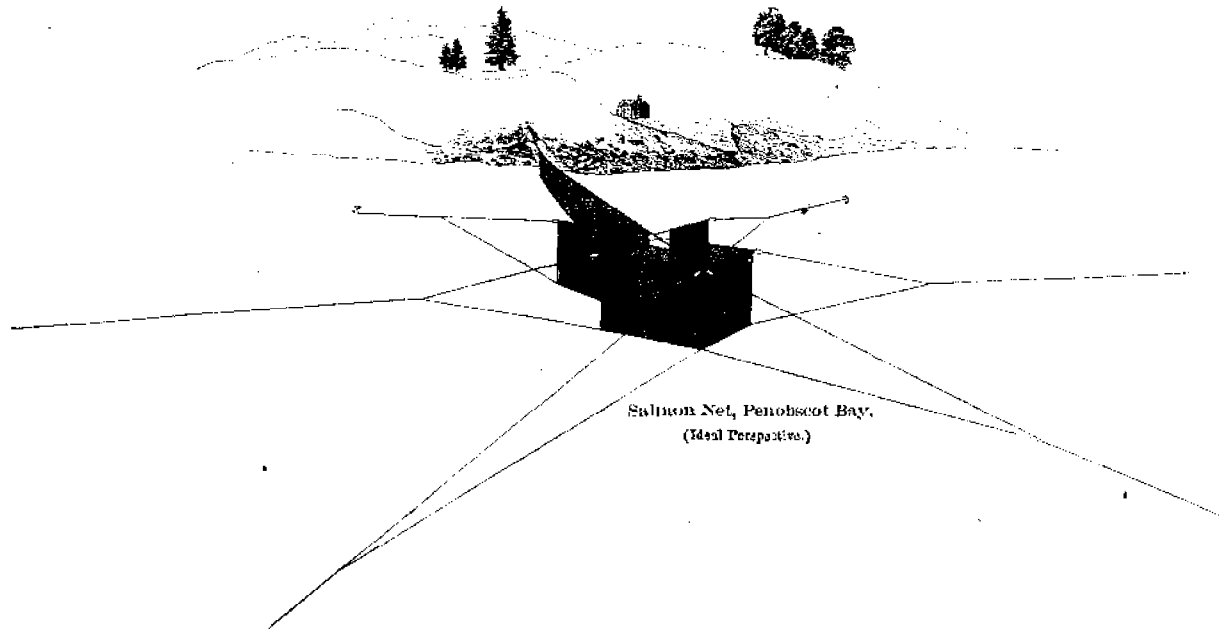

Salmon Net, Penobscot Bay.  
(Ideal Perspective.)

### THE RIVER FISHERIES OF MAINE.

Ideal perspective of salmon net in Penobscot Bay, Maine. (Sect. v, vol. i, p. 622.)

From Report U. S. Fish Commission, Part II, 1872-73.

## Plate 167.

### DIAGRAM OF SHAD-WEIR, KENNEBEC RIVER, MAINE.

The leader is a straight row of plain stakes  $2\frac{1}{2}$  to  $3\frac{1}{2}$  feet apart, running out from the shore, and varies in length according to the conformation of the bottom. The walls of the three pounds are formed by driving stakes into the bottom of the river and covering them with net of 2 to  $2\frac{1}{2}$  inch mesh, of 16 to 24 thread cotton twine. None of the pounds have any other bottom than the bottom of the river. The depth of water in the fish pound is from 2 to 15 feet at low tide.

In building a weir the points lettered are fixed by measurement, and all others by the eye.

The distances are as follows:

*a* to *b*, 14 feet. *b* to *c*, 14 feet. *c* to *d*, 4 feet. *d* to *e*, 18 feet. *e* to *f*, 5 feet. *f* to *g*, 5 feet. *g* to *k*, 25 feet. *g* to *h*, 16 feet. *h* to *i*, 2 feet. *i* to *j*, 16 feet. *b* to *m*, 38 feet. *e* to *n*, 20 feet. *i* to *o*, 18 feet. *a* to *l*, 24 feet.

The above dimensions are given by Mr. J. L. Browne, of Bowdoinham, as those of his weir, which is of usual form and dimensions.

A weir of this pattern is intended to take fish either ascending or descending the river. The fish outlines show their course in entering the weir and in working forward to the fish pound. From the fish pound they are taken with a "tuck" or "purse-seine." This implement has a wooden staff at either end, corks on the upper edge, and heavy sinkers on the lower edge. To the lower edge are also attached rings, through which runs the purse line, which passes up the staves to the hands of the fishermen; one staff is planted at *i* and the net is then paid out from the boat across the entrance and around by the wall at *g*, *k*, *o*, &c., until the two staves are brought together again at *i*, when the seine is pursed up, by hauling on the purse line, and the whole net with the inclosed fish is then hauled aboard the boat.

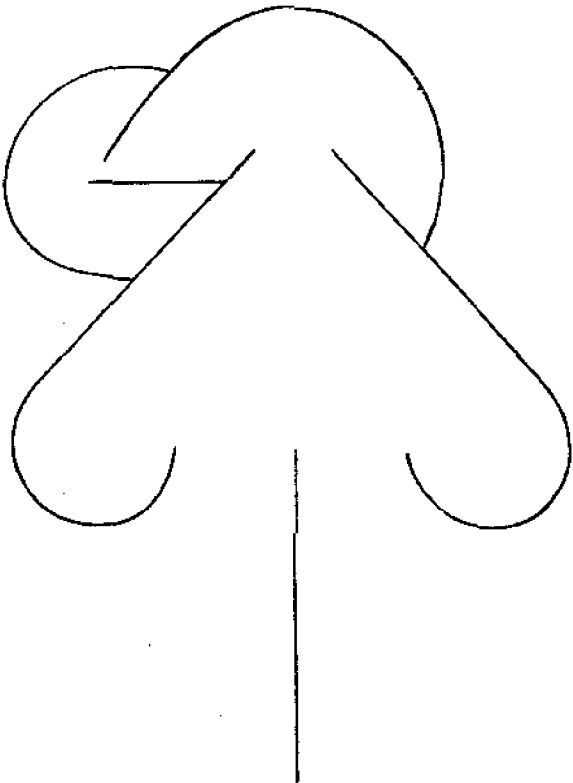
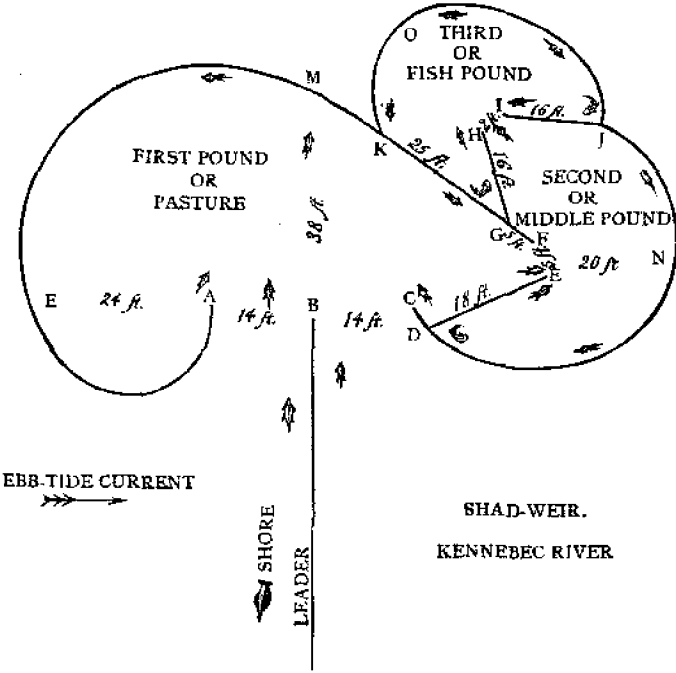

Second form.

**THE RIVER FISHERIES OF MAINE.**

(Sect. v, vol. i, p. 684. See, also, explanation opposite.)

## Plate 168.

### BAG-NET FISHING FOR SMELTS UNDER THE ICE, PENOBSCOT RIVER, MAINE.

A hole is cut in the ice, at right angles with the current, 30 feet long and 1 foot wide. Poles 40 feet long reach down 34 or 35 feet into the water.

The "jumper," a short rope, is made fast to the pole, runs down through the ice, and is toggled beneath. This keeps the pole down.

The "back line" runs from the top of the pole to a toggle under the ice 10 feet away, on a line with the poles.

The "end guy" runs from the foot of the pole to a toggle above the ice, about 25 feet from the pole.

The "ebb-tide guy," 80 feet long, runs from the foot of the pole up the stream to a toggle above the ice.

The "flood-tide guy," 80 feet long, runs from the foot of the pole to a toggle in the ice.

The down-haul part of the halliards reeves through a block at the foot of the pole and thence passes up through the hole to a thimble near the top of the pole.

The up-haul part of the halliards reeves through six thimbles on the hoist-rope of the net, and passes thence up through the hole and reeves through a thimble near the top of the pole, where it is continuous with the down-haul part. When the net is set, to prevent the halliards yielding to the draft of the tide, their lights are crossed back of the pole, brought forward again, and toggled as shown.

The "opener" is made fast to the upper corner of the net. After the halliards are hauled home and toggled, the mouth of the net is opened by this rope, the upper end of which is made fast to any convenient part above.

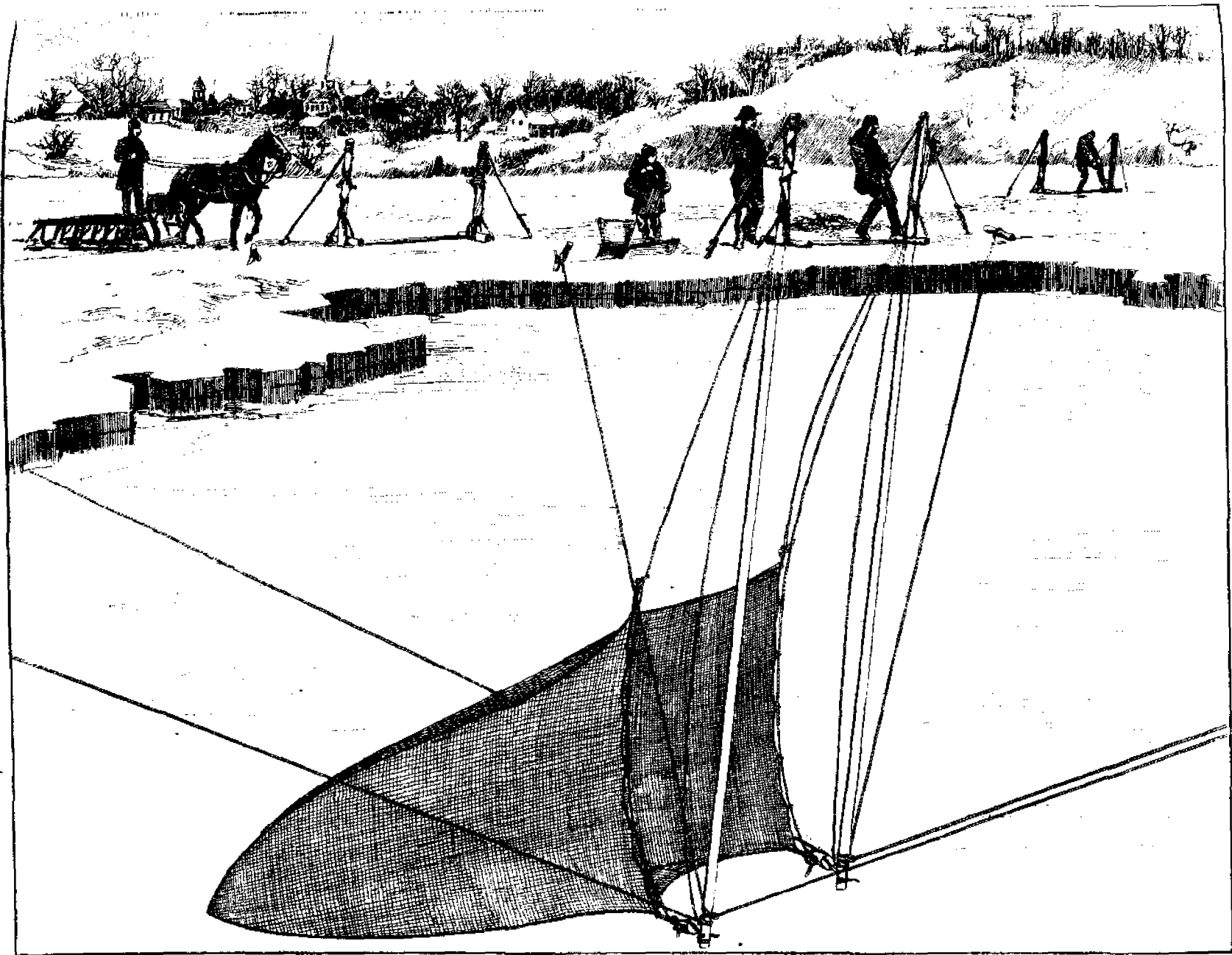

THE RIVER FISHERIES OF MAINE.

Bag-net fishing for smeits under the ice, Penobscot River, Maine. (Sect. v, vol. i, p. 691. See, also, explanation opposite.)

From sketch by C. G. Atkins.



**THE SALMON INDUSTRY OF THE PACIFIC COAST.**

Salmon cannery at Astoria, Oregon. (Sect. V, vol. I, p. 745.)

From a photograph.

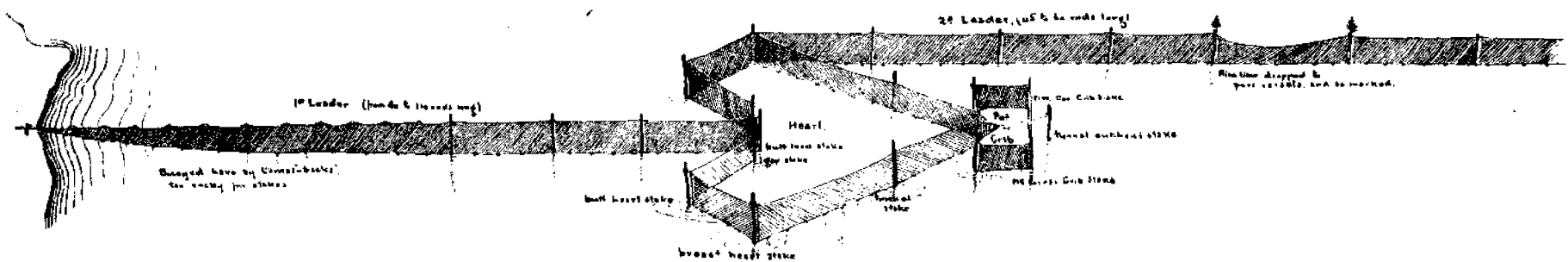
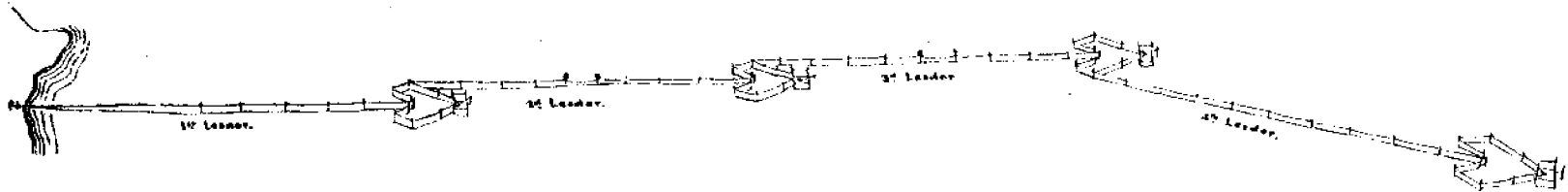

**THE FISHERIES OF THE GREAT LAKES.**

Kelley's pound-net, near Carpenter's Point, Lake Erie, for capture of whitefish, herring, &c. (Sect. v, vol. i, p. 758.)

White-oak stakes, 30 to 60 feet long, 6 inches to 1 foot diameter: the leader stakes 5 to 6 feet apart. Rim line to leader and heart just at water surface. Rim line to pot about 2 feet above surface. Bottom line to leader and heart fixed with stone sinkers.

Drawing by H. W. Elliott.



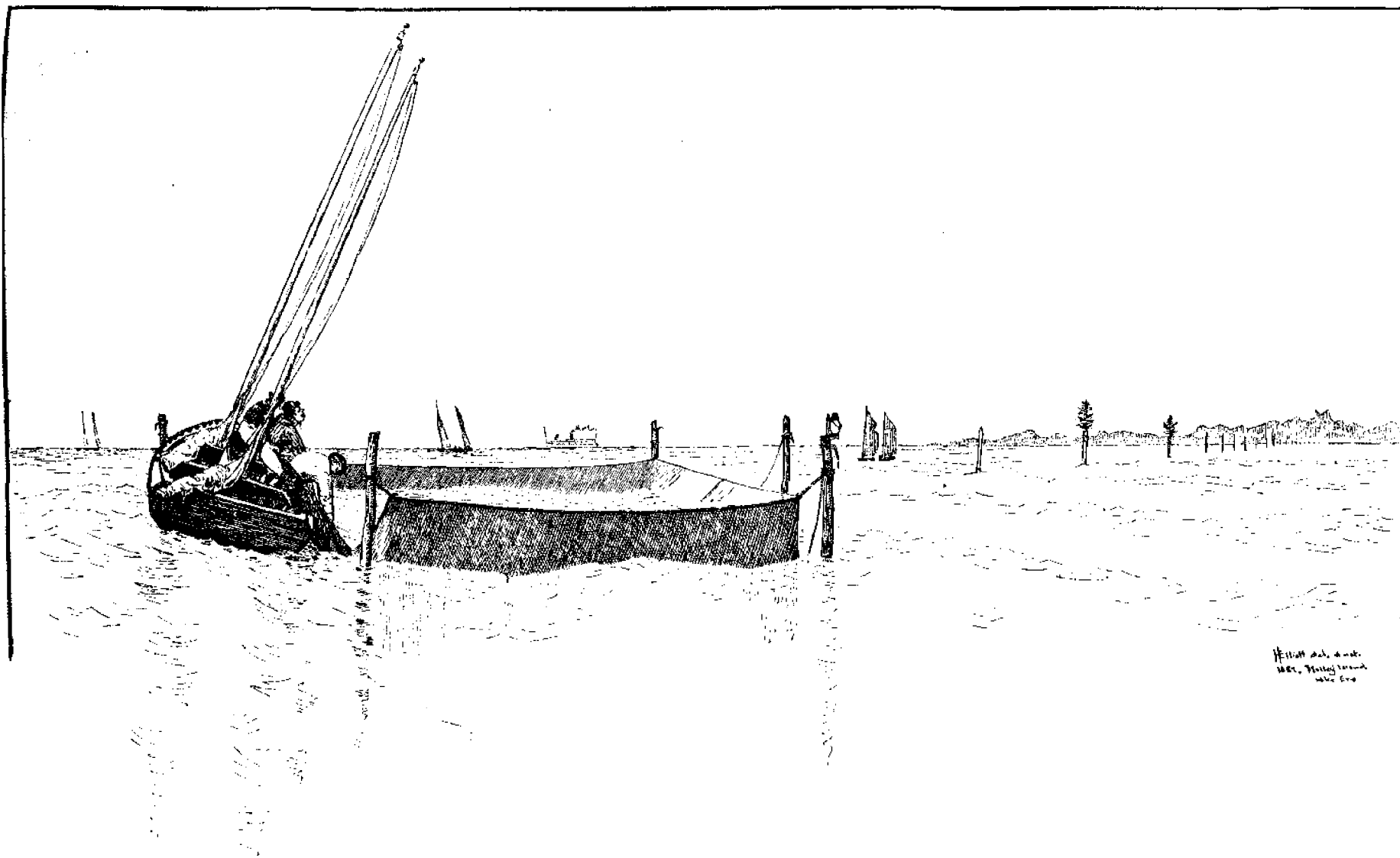

**THE FISHERIES OF THE GREAT LAKES.**

"Lifting the pot" at Kelley's pound-net, Lake Erie. (Sect. v. vol. i. p. 760.)

Drawing by H. W. Elliott.

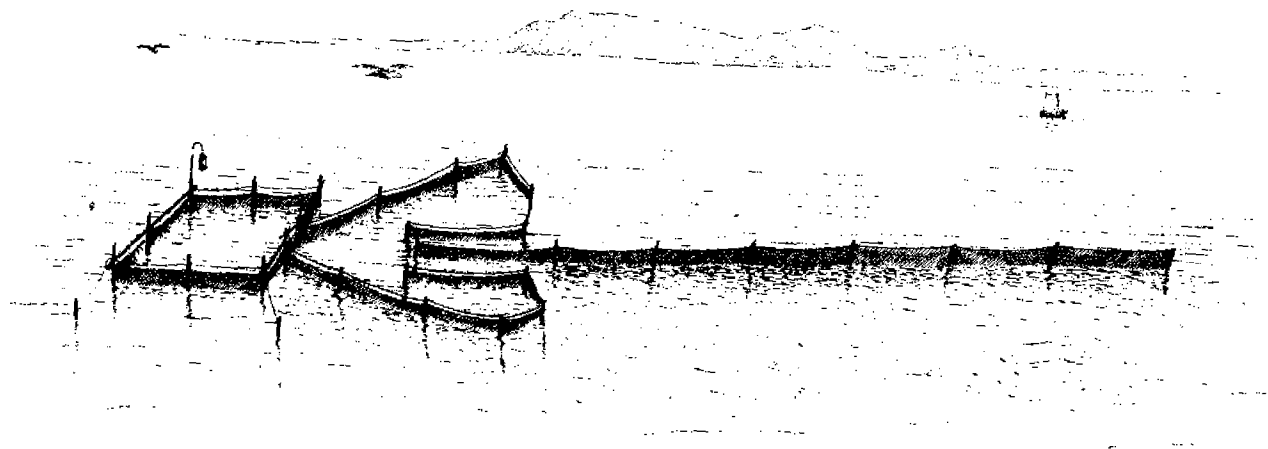

**THE FISHERIES OF THE GREAT LAKES.**

Green Bay pound-net, off Ingleson's fishery. (sect. v, vol. i, p. 758.)

Drawing by L. Kaulben.

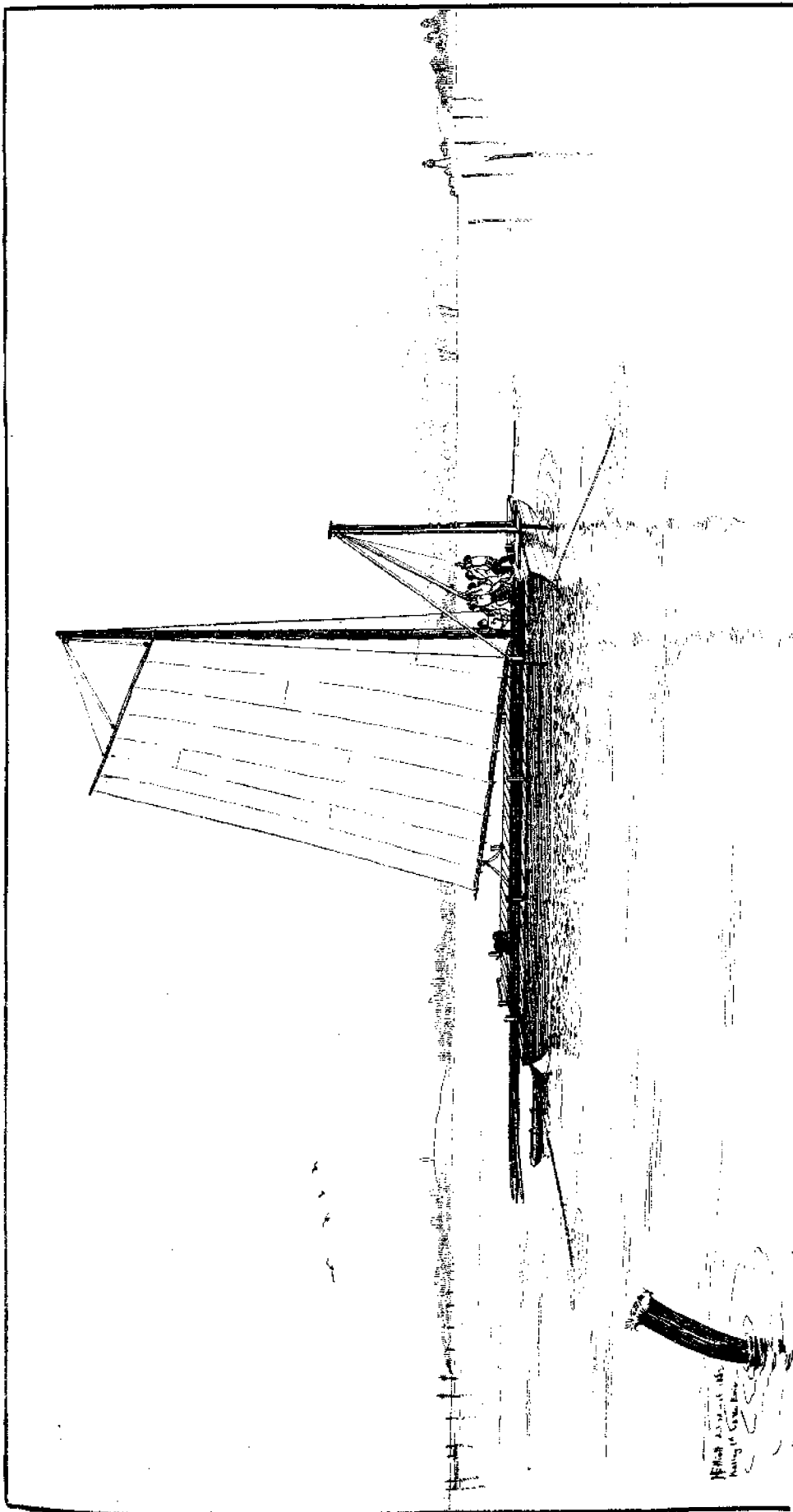

**THE FISHERIES OF THE GREAT LAKES.**

“Driving the pound;” Stake-boat and crew off Marble-head, Lake Erie, driving stakes for pound-net. (At close of the season the other end of the same boat pulls the stakes.)  
(Sect. v, vol. i, p. 549.)

Drawing by H. W. Elliott.

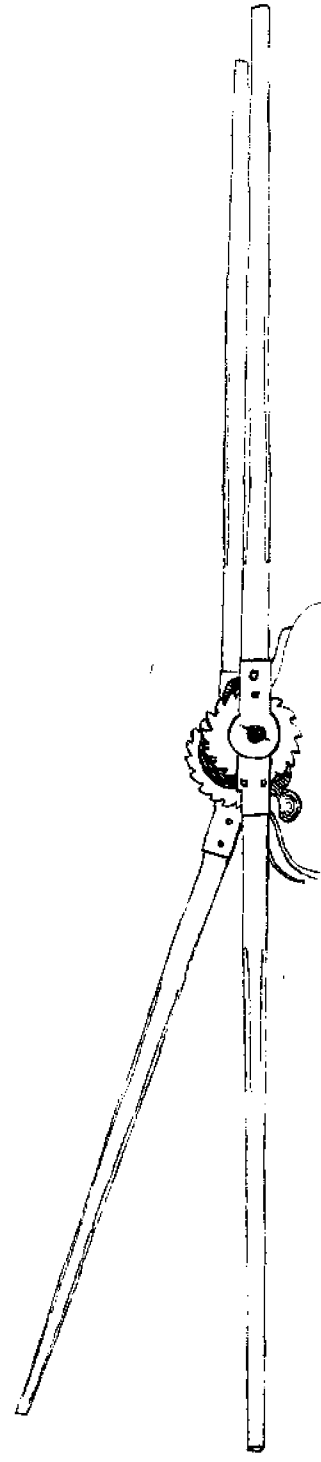
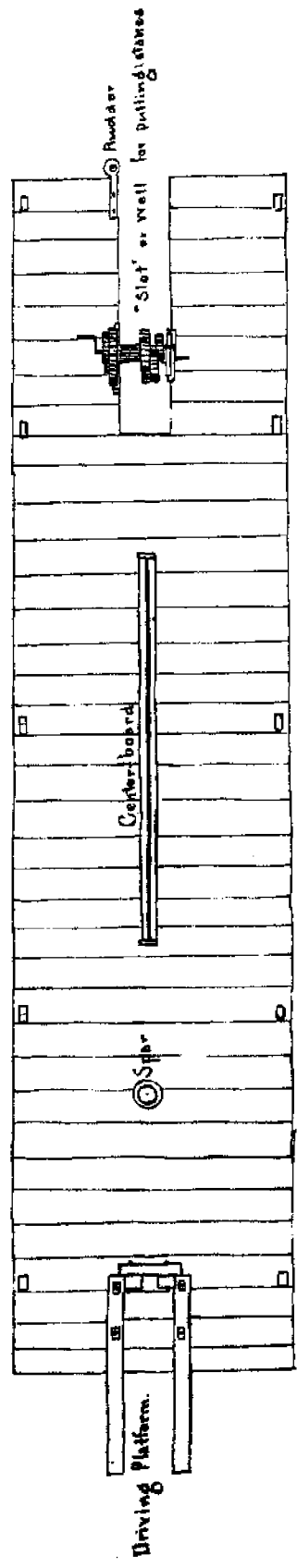

THE FISHERIES OF THE GREAT LAKES.

Deck plan of stake-boat and stake-puller of Lake Erie. (Sect. V, vol. 1, p. 760.)

Drawing by H. W. Elliott.

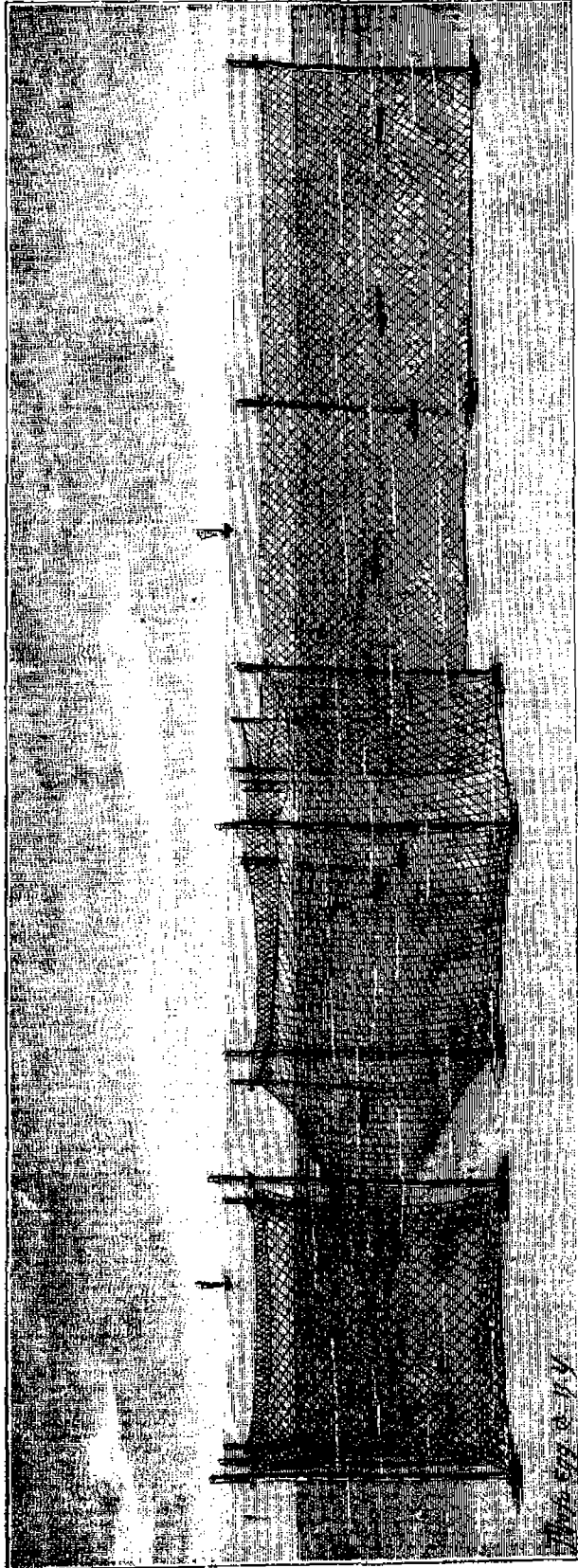

THE FISHERIES OF THE GREAT LAKES.

Pound-net at Detroit River. (Sect. v, vol. i, p. 758.)

From sketch by L. Kunthien.



**THE FISHERIES OF THE GREAT LAKES.**

“Baiting out the net” of pound-net at Detroit River. (Sect. V, vol. I, p. 762.)

From sketch by L. Kumbier.



THE FISHERIES OF THE GREAT LAKES.

Camp at South Manitou Island, Lake Michigan: fishing boats; gill-nets on reel; slantly for cleaning fish. (Seef. v. vol. 1, p. 262.)

From a photograph by U. S. Geological Survey.

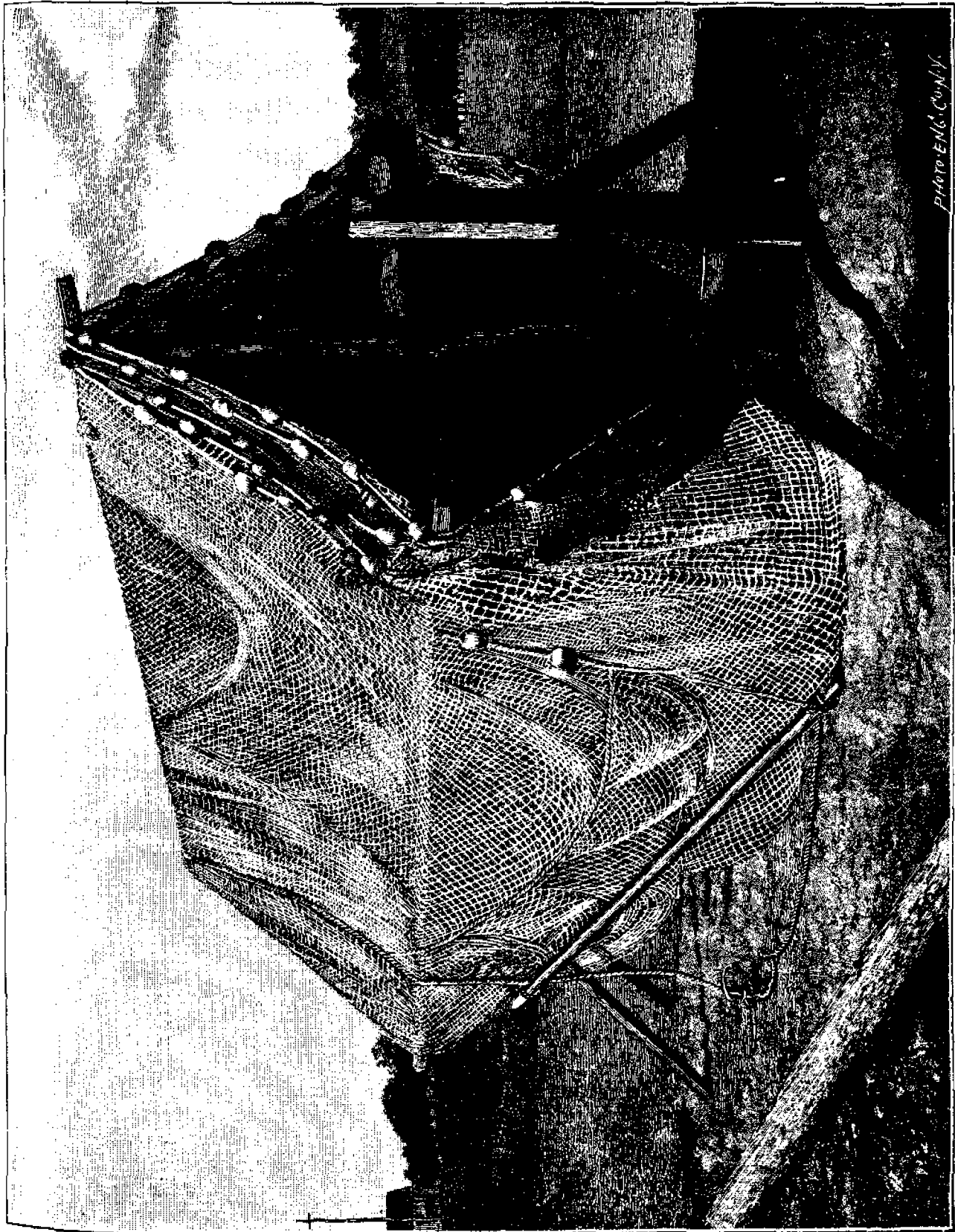

*Photo-Eng. Co. N.Y.*

**THE FISHERIES OF THE GREAT LAKES.**

Gill-net drying on reel. (Sect. v, vol. 1, p. 764.)

From a photograph.



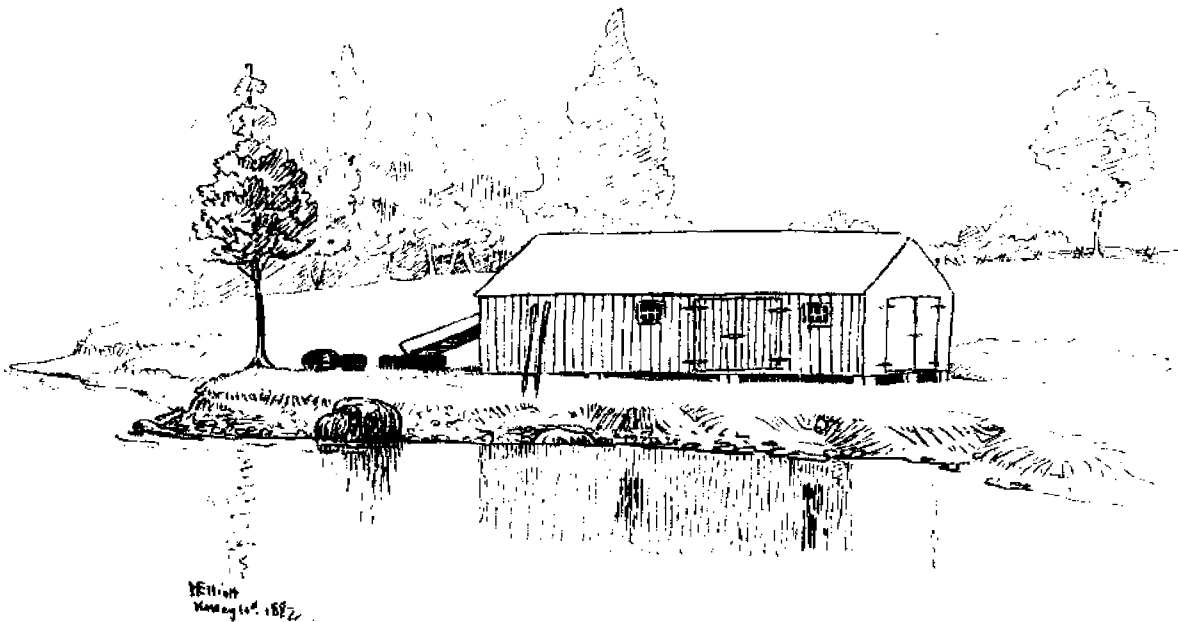
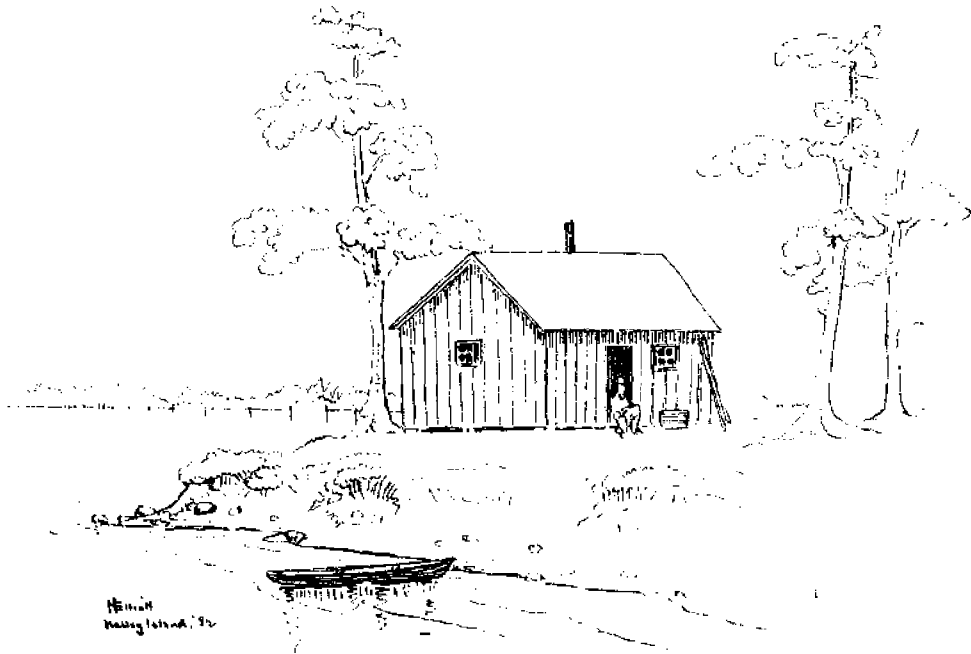

**THE FISHERIES OF THE GREAT LAKES.**

Type of fishermen's summer house; seine-shed and tarring-box annexed. (Sect. v, vol. i, p. 765.)

Drawings by H. W. Elliott, 1882.

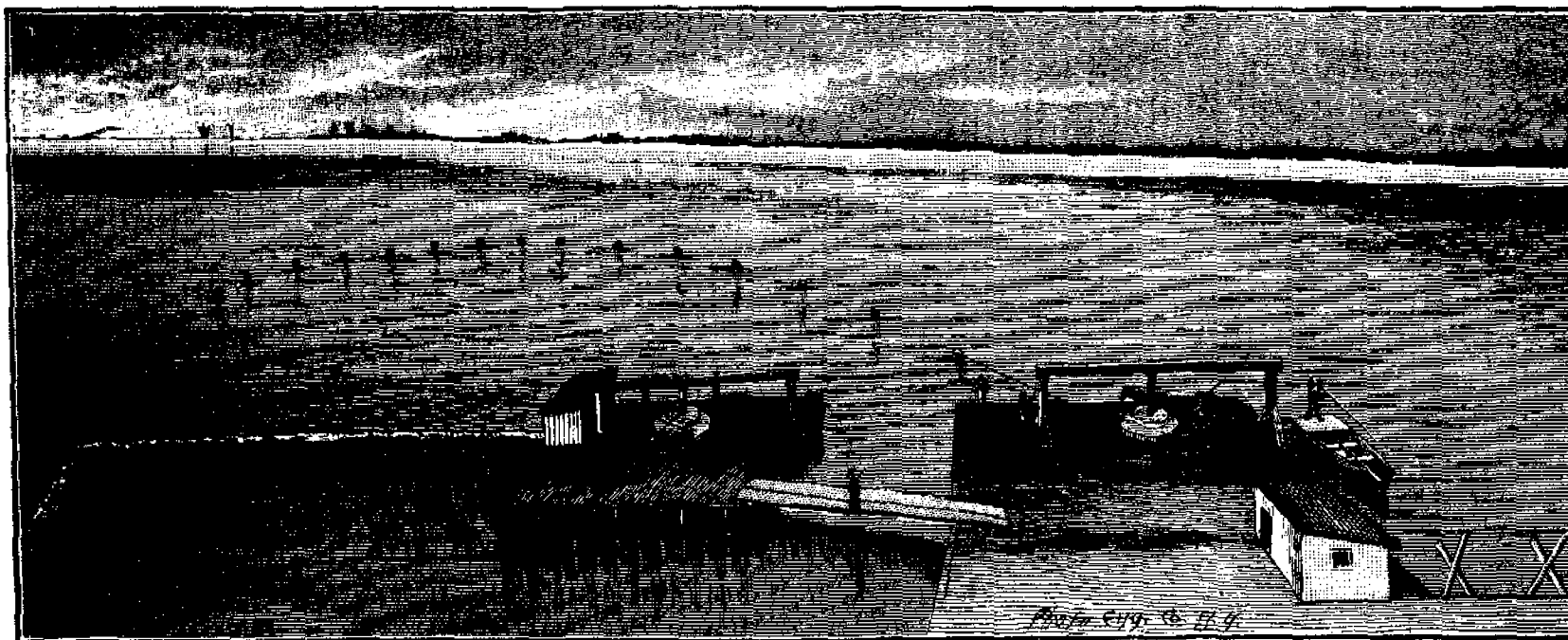

THE FISHERIES OF THE GREAT LAKES.

Hauling in herring seine at Herbert's Fishery, Detroit River; inclosure for keeping fish alive. (Sect. v, vol. i, p. 766.)

Sketch by L. Kunlien.

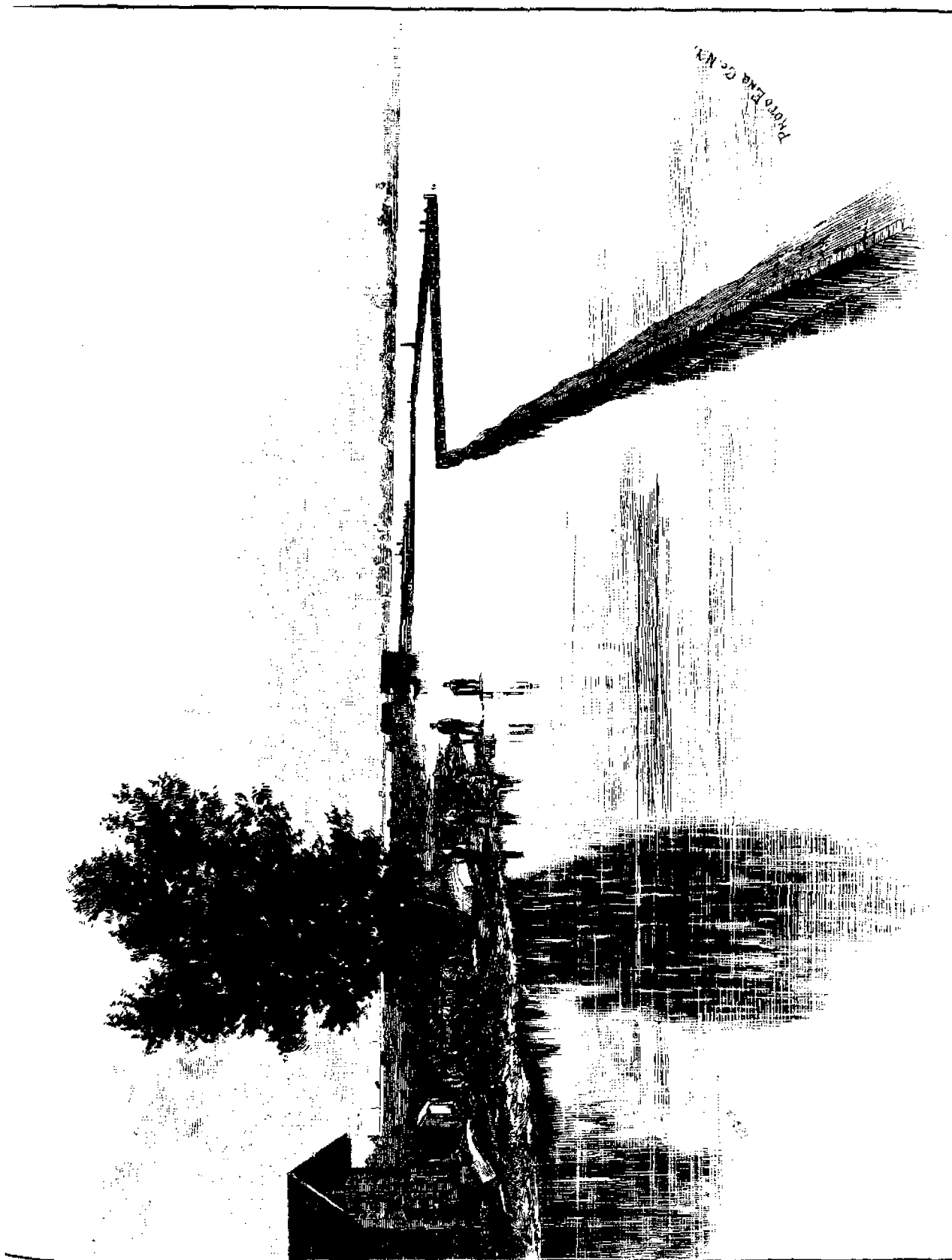

**THE FISHERIES OF THE GREAT LAKES.**

Pond fishery, Detroit River: enclosure for keeping fish. (Sect. V, vol. i, p. 766.)

From a photograph by U. S. Fish Commission.

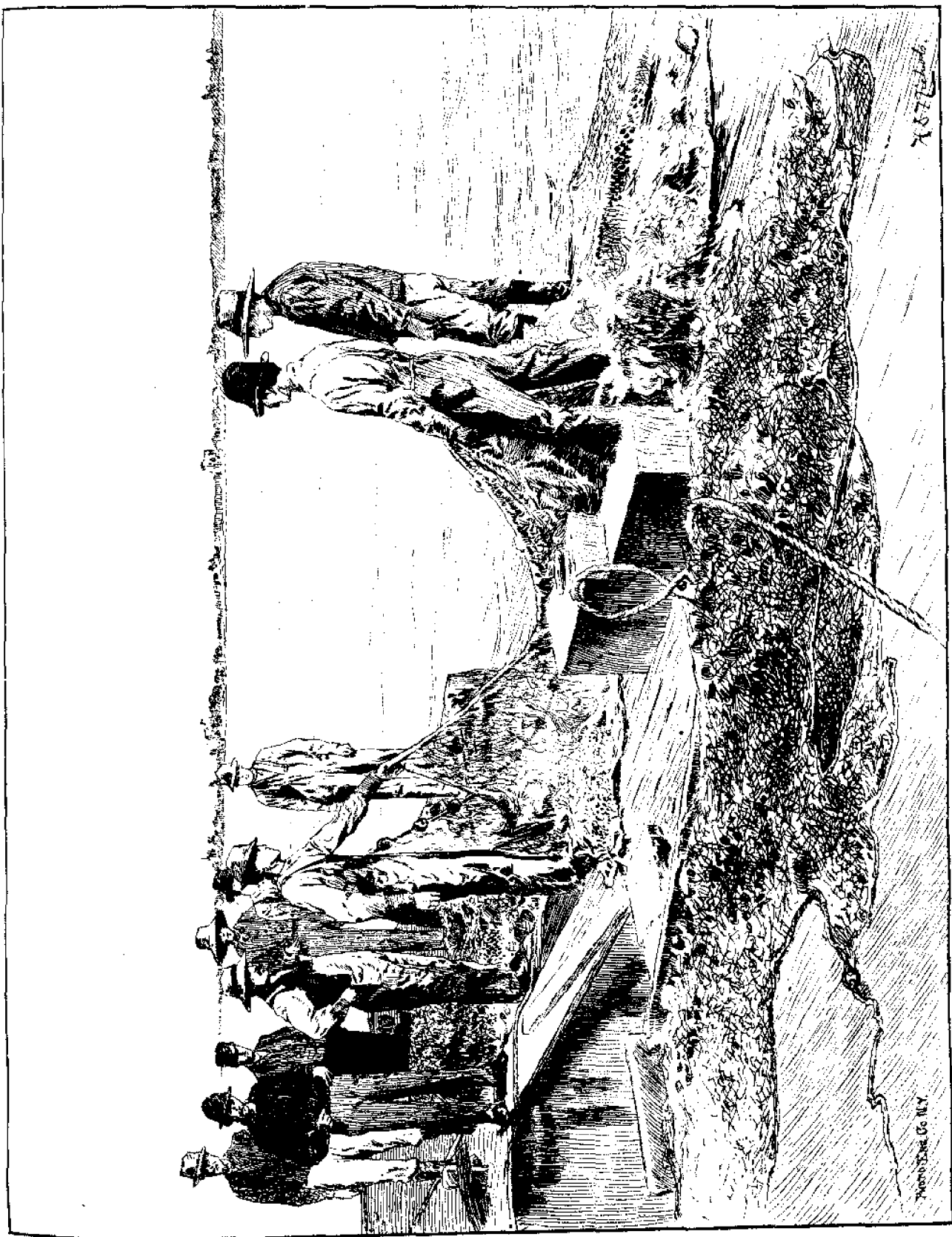

**THE FISHERIES OF THE GREAT LAKES.**

Overhauling the seine at Grassy Island fishery, Detroit River. (Sert. v. vol. i. p. 786.)

From a photograph.

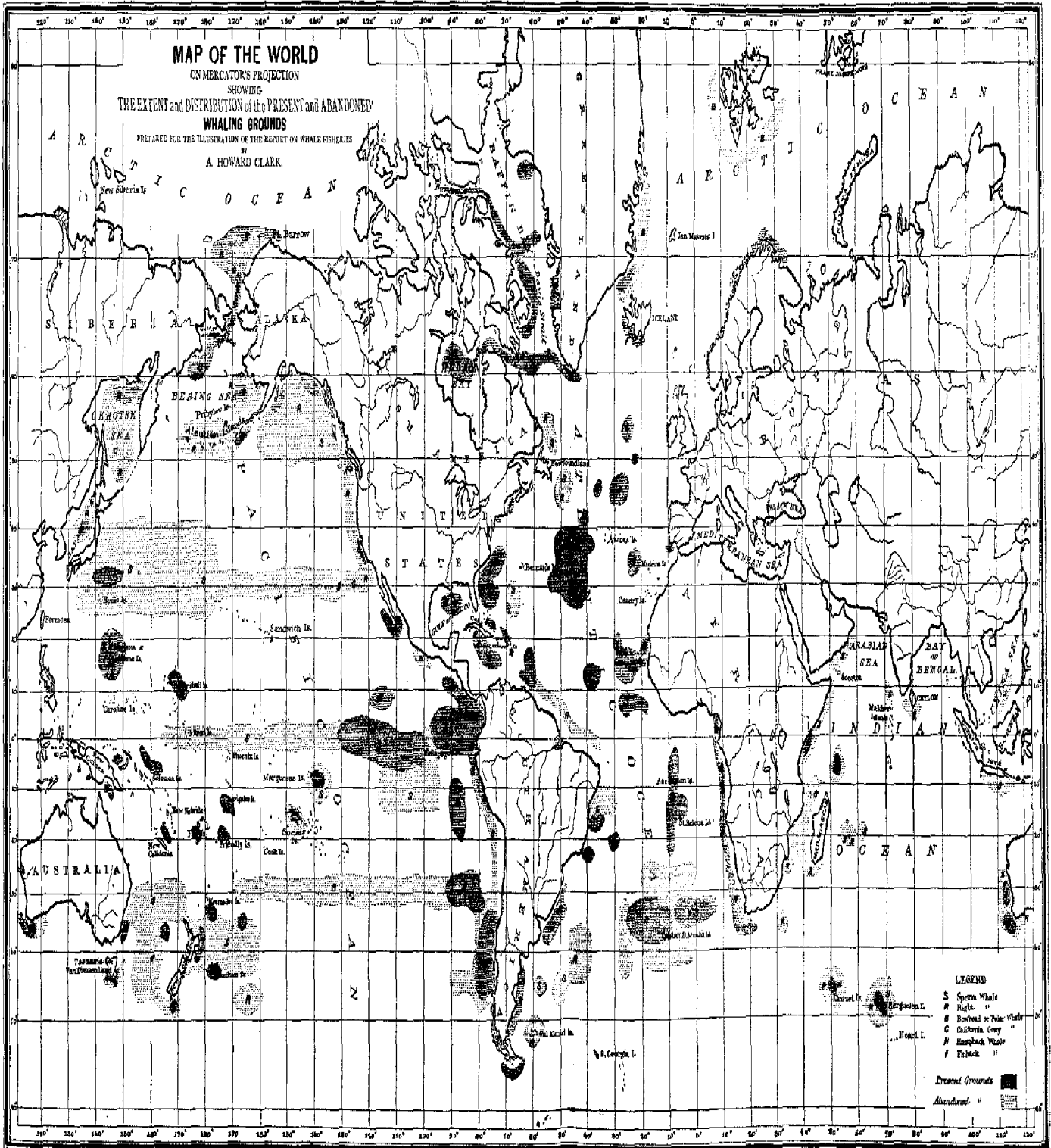



Fig. 1.

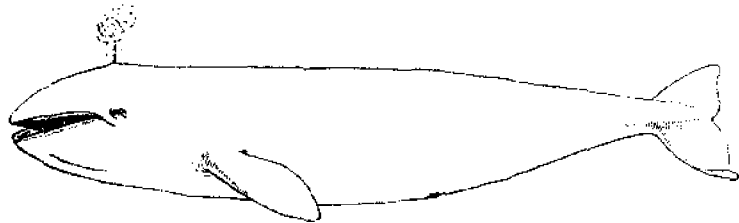

Fig. 2.

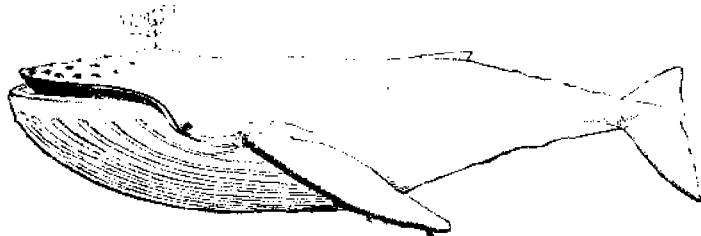

Fig. 3.

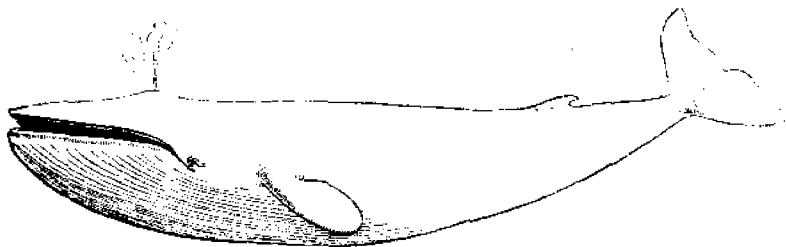

Fig. 4.



Fig. 5.

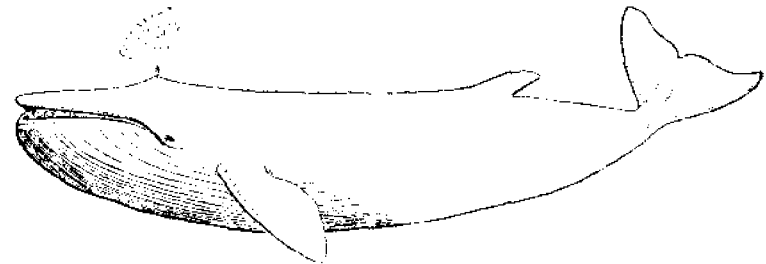

Fig. 6.



Fig. 7.

### THE WHALE FISHERY.

- FIG. 1. The Sperm Whale (*Physeter macrocephalus*).  
 FIG. 2. The California Gray Whale (*Rhachianectes glaucus*).  
 FIG. 3. The North Pacific Humpback (*Megaptera vosahilis*).  
 FIG. 4. The Sulphur-bottom (*Sibbaldius sulforens*)

- FIG. 5. The Bowhead (*Balaena mysticetus*).  
 FIG. 6. The Fin-back or Oregon Finner (*Balainoptera rosifera*).  
 FIG. 7. The Pacific Right Whale (*Balaena japonica*).

Outlines from Seaton's Marine Mammalia.

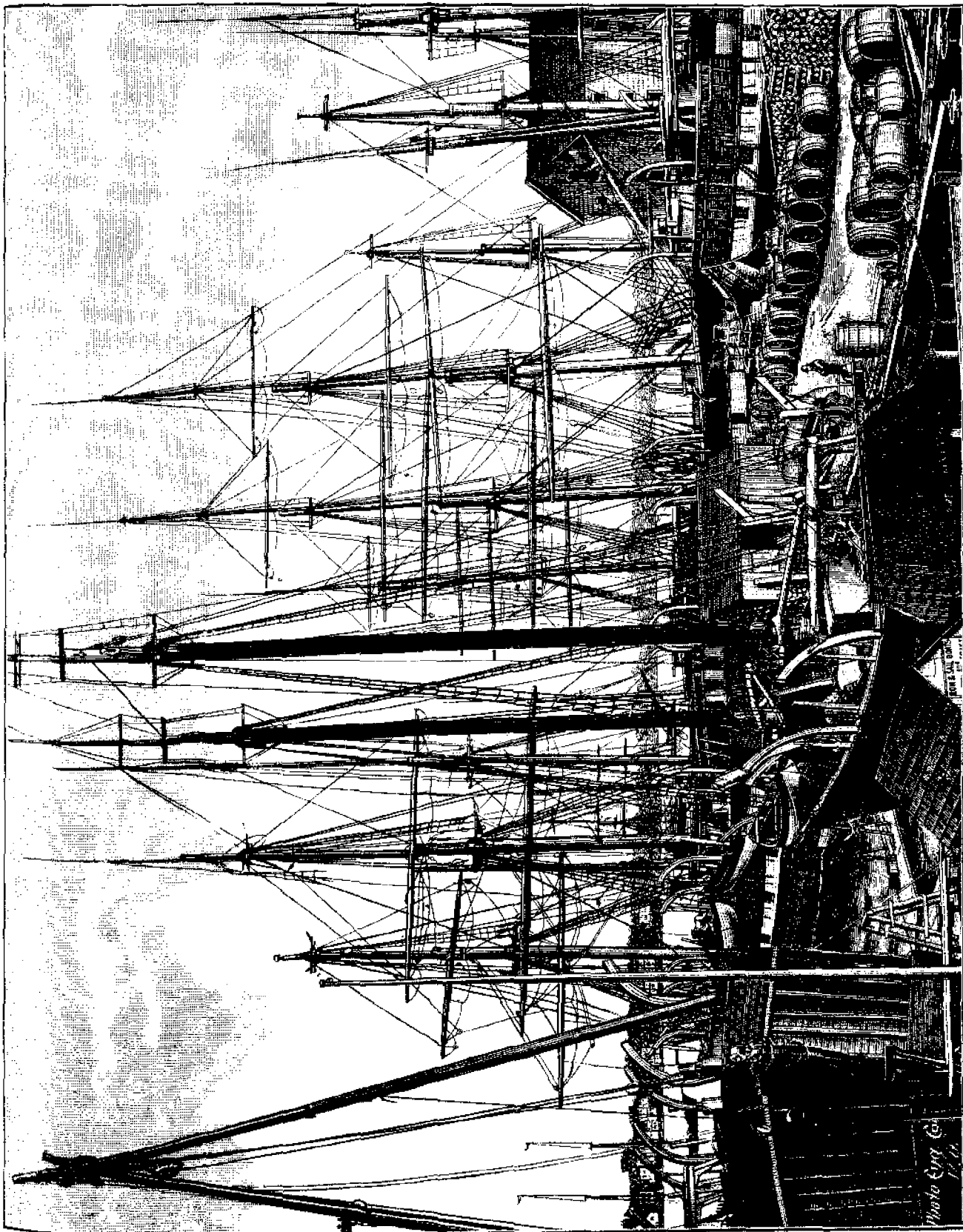

**THE WHALE FISHERY.**

Whaling vessels at New Bedford wharves. (Sect. v, vol. ii, p. 232.)

From a photograph by T. W. Sanille.

Photo Copy Co.  
1877

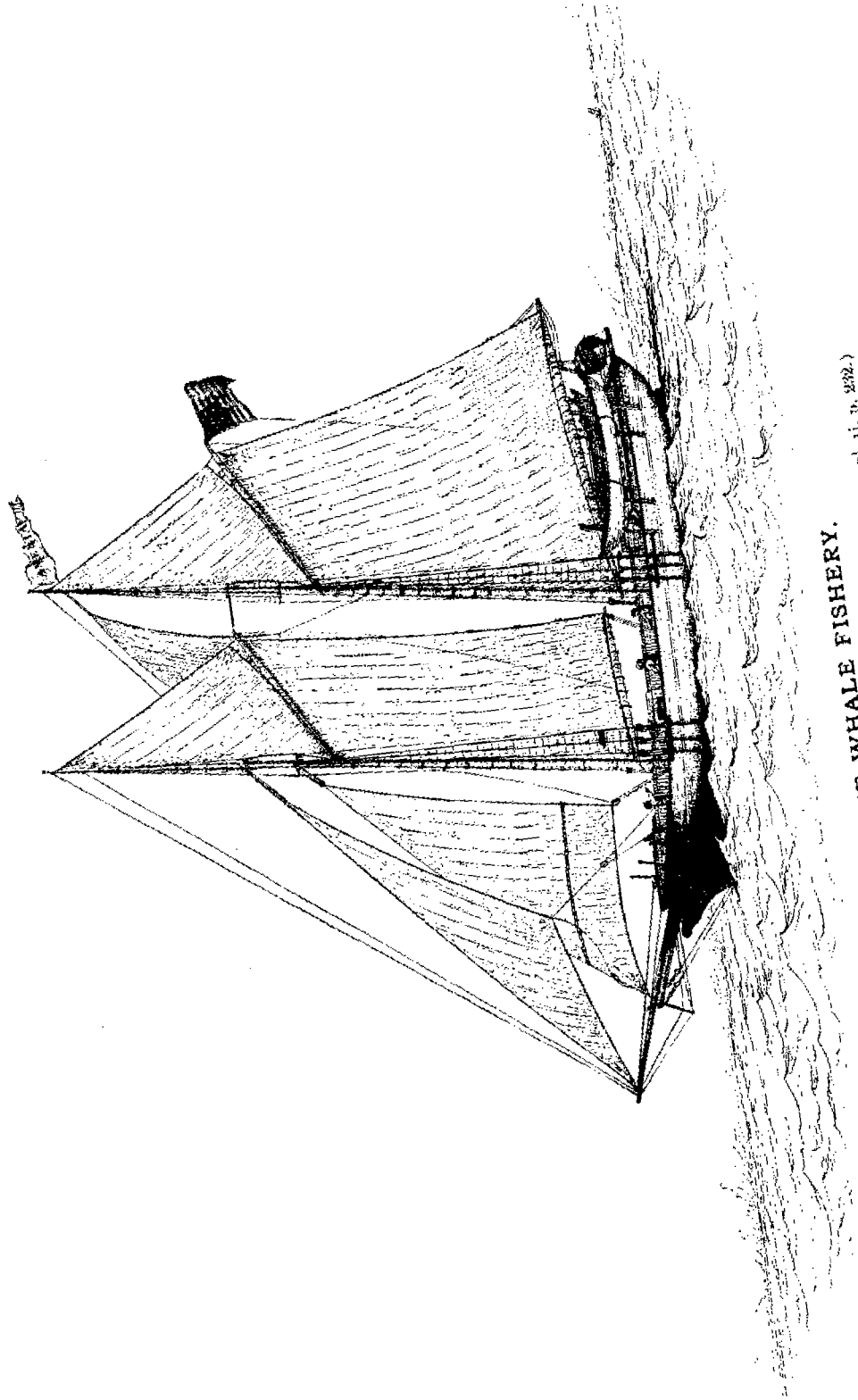

**THE WHALE FISHERY.**

(Sect. v, vol. 11, p. 232.)

Whaling schooner Amelia, of New Bedford, Mass.

Drawing by C. S. Raleigh.



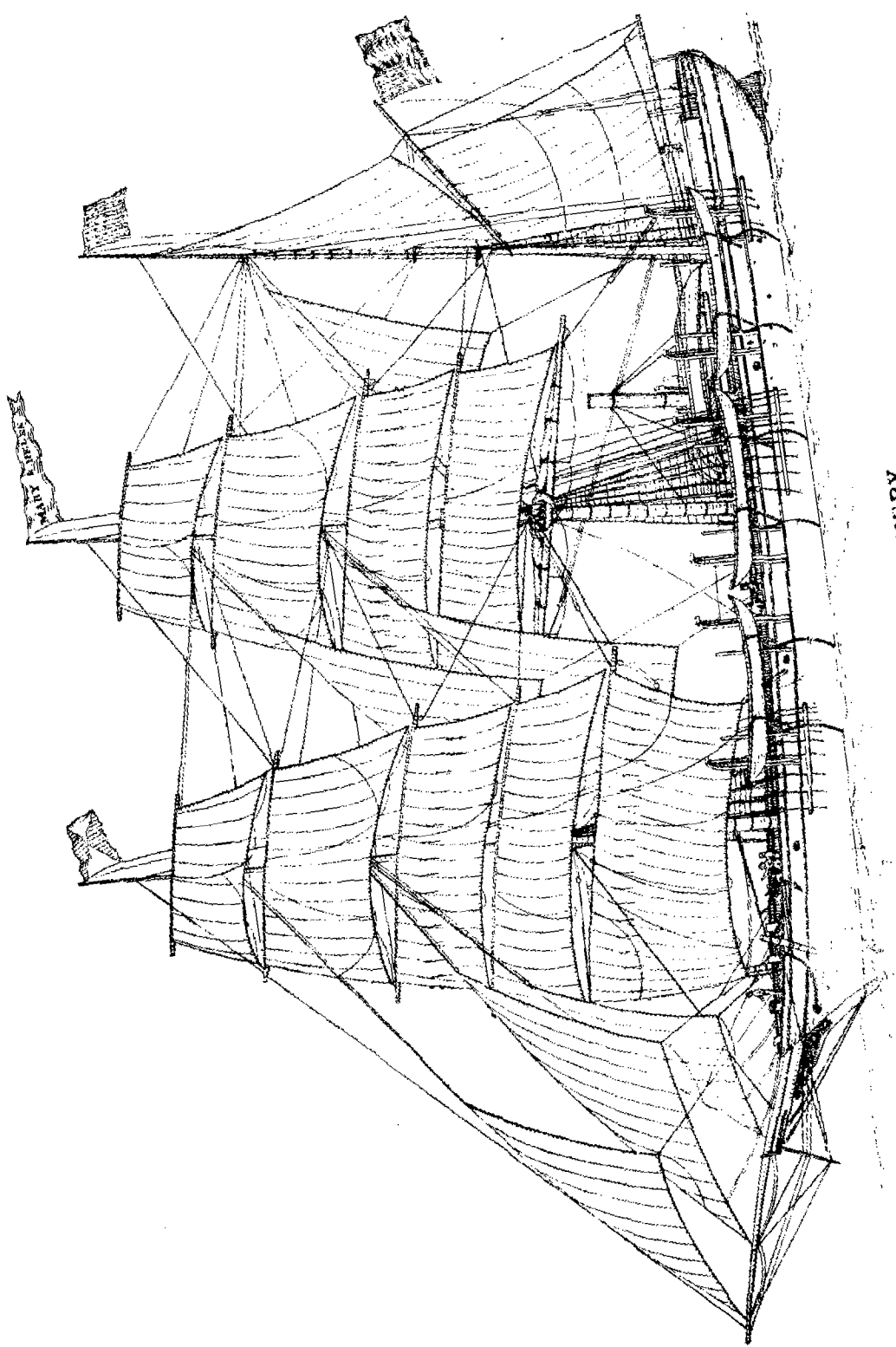

**THE WHALE FISHERY.**  
Steam whaling bark Mary & Helen, of New Bedford, Mass. (Sect. v, vol. ii, p. 286.)  
Drawing by C. S. Raleigh.

Plate 188.

DECK PLAN AND SIDE AND INTERIOR PLAN OF WHALING SCHOONER AMELIA, OF NEW BEDFORD,  
MASS.

95.44 tons.

FIG. 1. DECK PLAN.—1, Heel of bowsprit. 2, Paul-bitt. 3, Windlass and bitts. 4, Forecastle companion. 5, Fluke-chain bitt. 6, Foremast. 7, Cable boxes. 8, Try-pots. 9, Try-works. 10, Chimneys or try-works pipes. 11, Cooler. 12, Scrap-hopper. 13, Main hatch. 14, Fore-sheet block. 15, Mainmast. 16, Prumps. 17, After hatch. 18, Galley or cook's office. 19, Deck-steps (small ladders leading from the main deck to the cabin deck). 20, Cabin skylight. 21, Cabin companion. 22, Binnacle. 23, Steering wheel. 24, Steering screw box. 25, Fore channels. 26, Main channels. 27, Cutting-in gaugway. 28, Whale boats on the cranes. 29, Skids for spare boats. 30, Boat davits. 31, Cat-heads.

FIG. 2. SIDE AND INTERIOR PLAN.—1, Bowsprit. 2, Paul-bitt. 3, Windlass and bitts. 4, Forecastle companion. 5, Foremast. 6, Forecastle. 7, Chain cable box. 8, Try-pots. 9, Try-works. 10, Chimney and flue. 11, Main hatch. 12, Locker for coal. 13, Casks for oil. 14, Ship stores, gear, &c. 15, Captain's store-room. 16, Captain's cabin. 17, Steerage. 18, Mainmast. 19, After hatch. 20, Galley. 21, Cabin skylight. 22, Cabin companion. 23, Side whale boat. 24, Steering screw box. 25, Stern whale boat. 26, Spare spars, oars, &c. 27, Boat davits. 28, Boat bearers. 29, Main hold. 30, Cat-head. 31, Cutting blocks, gear, &c. 32, Pumps. 33, Main channels. 34, Fore channels.

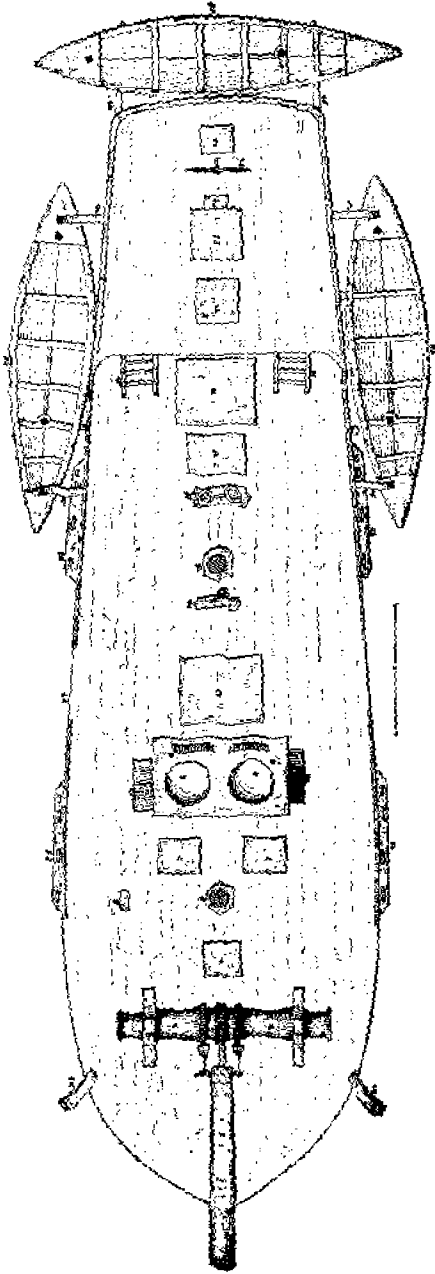

Fig. 1.

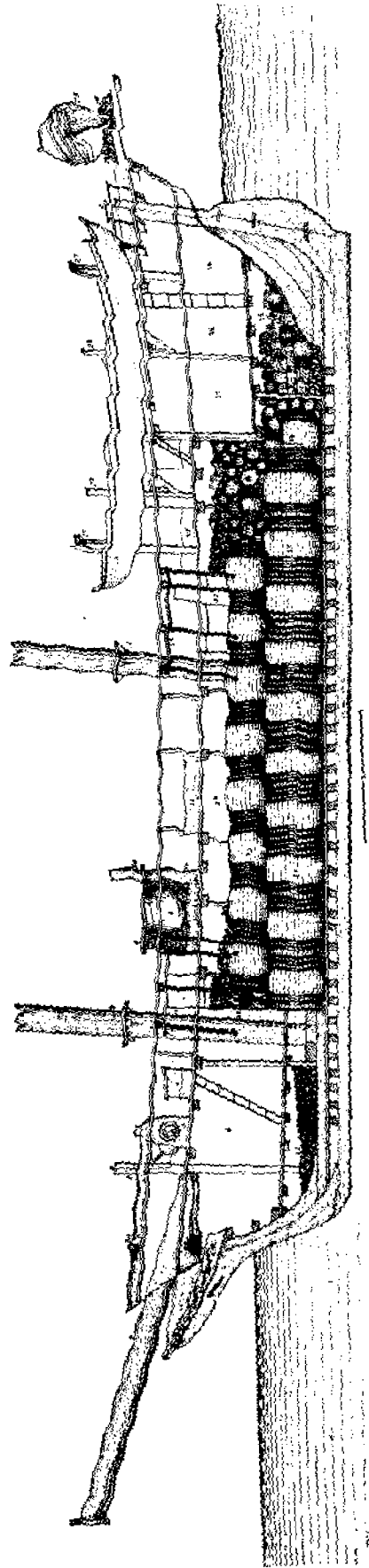

Fig. 2.

**THE WHALE FISHERY.**

Deck plan and side and interior plan of the whaling schooner *Amelia*, of New Bedford, Mass. (Sect. V, vol. ii, p. 234.)

Drawing by E. S. Hilditch.  
[See explanation opposite.]

## Plate 189.

### DECK PLAN AND SIDE AND INTERIOR PLAN OF WHALING BARK ALICE KNOWLES OF NEW BEDFORD, MASS.

302.78 TONS.

FIG. 1. DECK PLAN.—1, Heel of bowsprit. 2, Paul-bitt. 3, Cat-heads. 4, Windlass and bitts. 5, Forecastle companions. 6, Fluke-chain bitt. 7, Foremast. 8, Fore hatch. 9, Try-pots. 10, Try-works. 11, Cooler. 12, Scrap-hopper. 13, Work-bench. 14, Chimney and flue. 15, Main hatch. 16, Mainmast. 17, Pumps. 18, Deck-house. 19, Spare boats. 20, Galley. 21, Mizzen-mast. 22, Cabin skylight. 23, After deck house. 24, Wheel and screw box. 25, Fore channels. 26, Main channels. 27, Cutting-in gangway. 28, 28, 28, 28, Whale boats on cranes for active service. 29, Boat-davits. 30, Mizzen-chains. 31, Bit (for the belly-chain of the whale).

FIG. 2. SIDE AND INTERIOR PLAN.—(Scale one-sixteenth inch to foot.) 1, Bowsprit. 2, Paul-bitt. 3, Cat-head. 4, Windlass and bitts. 5, Figure-head. 6, Forecastle companion. 7, Hawse-chocks. 8, Foremast. 9, Forecastle. 10, Fore hold shooks, gear, &c. 11, Casks for oil (riders). 12, Casks for oil (between decks). 13, Fore 'tween decks. 14, Blubber room. 15, Try-works. 16, Steerage. 17, Chain locker and pumps. 18, After hold (stores, gear, &c.). 19, After peak (captain's stores, &c.). 20, Captain's cabin. 21, Galley. 22, Skids for spare boats. 23, Mainmast. 24, Mizzen-mast. 25, After house. 26, Boat davits. 27, Whale boats. 28, Boat bearers. 29, Main hatch. 30, Fore hatch. 31, Booby hatch. 32, Cabin skylight. 33, Wheel and screw box. 34, Cranes for boats. 35, Lower main hold. 36, After 'tween deck. 37, Fore channels. 38, Main channels. 39, Mizzen channels.

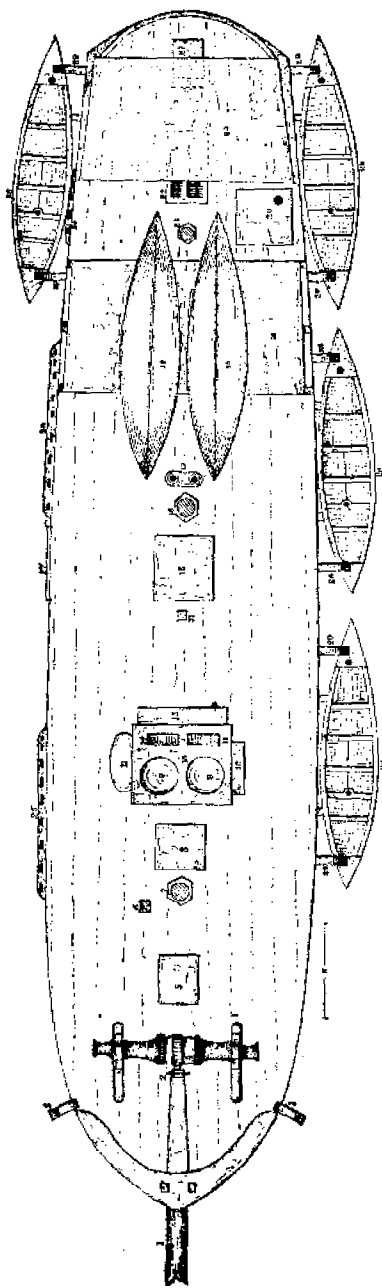

Fig. 1.

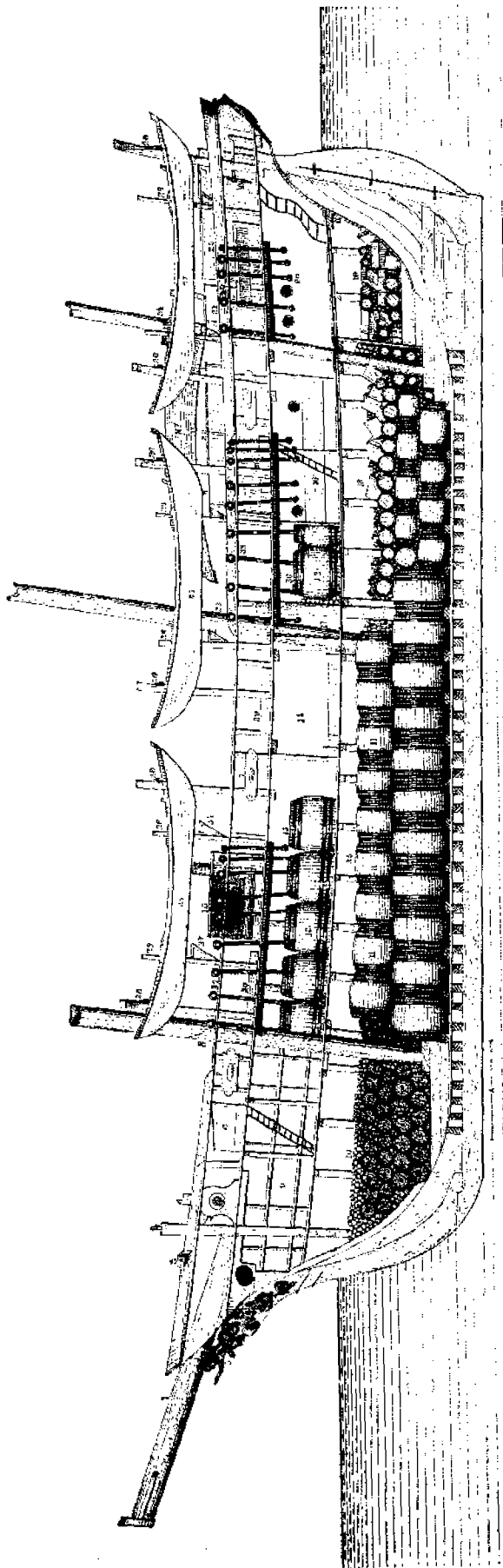

Fig. 2.

### THE WHALE FISHERY.

Deck plan and sectional plan of whaling bark Alice Knowles, of New Bedford, Mass. (Sect. v, vol. ii, p. 234.)

Drawing by C. S. Talough.

[See explanation opposite.]

## Plate 190.

STARBOARD QUARTER OF A WHALE SHIP SHOWING THE MANNER OF TRANSPORTING THE CAPTAIN'S BOAT AND THE SPARE BOATS.

- a.* Whale-boat on cranes transported to whaling grounds.
- b, b, b.* Bearers against which the inboard side of boat rests.
- c, c.* Crane upon which keel of boat rests.
- d, d.* Davits.
- e, e.* Hoisting straps.
- f, f.* Davit-tackle falls for hoisting and lowering.
- g, g.* Grips for lashing boat to prevent chafing.
- h, h.* Iron cranes to hold boat in position.
- i.* Spare boat on skids or gallows' frame.
- j.* End of skid resting on stanchion.
- k.* Lashing to hold boat in position.
- l, l, l, l.* Stroude.
- m, m, m, m.* Backstays; top-mast, topgallant, and royal backstays.
- n.* Main brace.
- p, p, p, p, p.* Running rigging.
- q.* Mizzen-mast.
- r, r.* Ratlines.
- s.* Spanker boom.
- t.* Spanker jackstay.
- u.* Channels.
- v.* Chain plates.

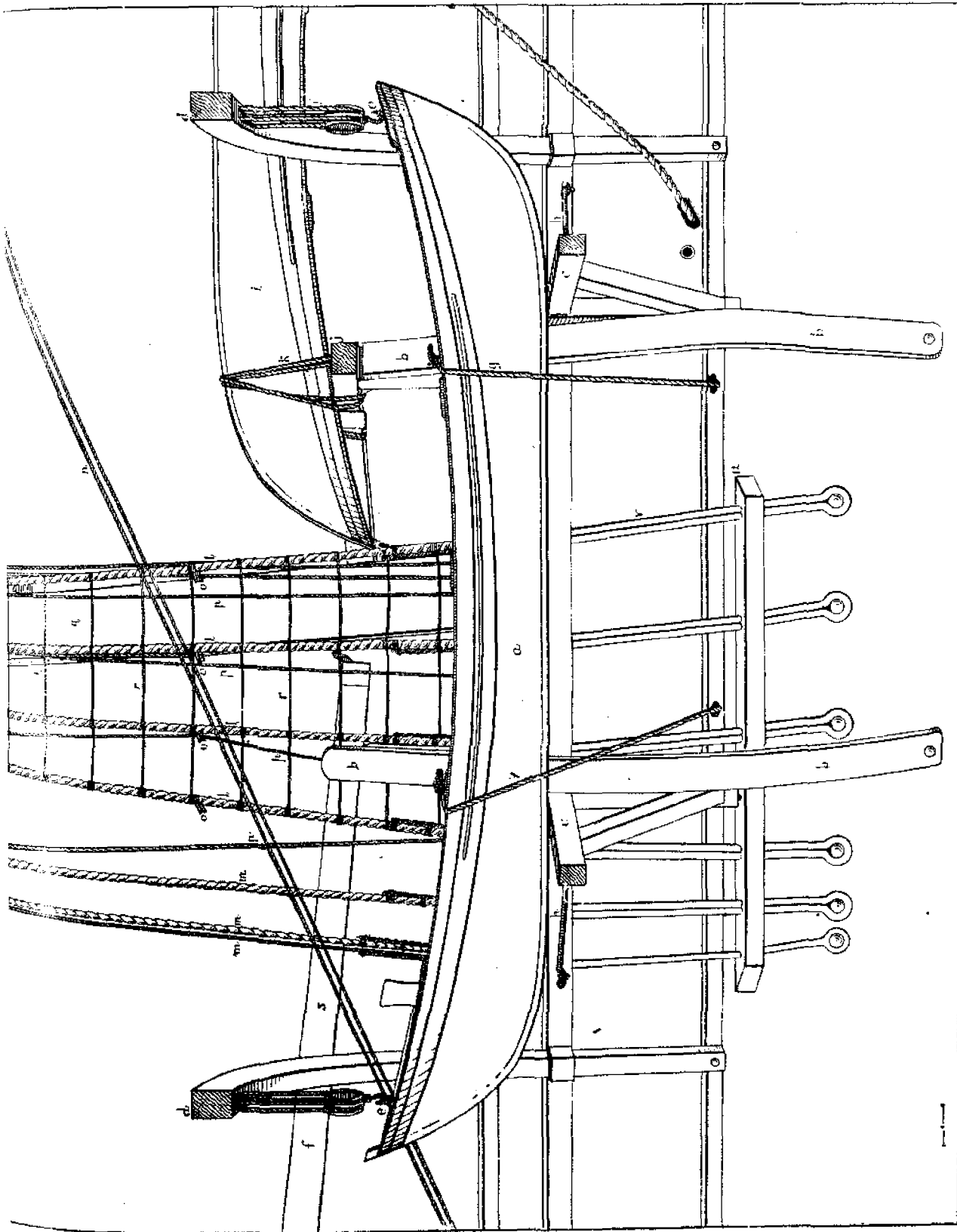

**THE WHALE FISHERY.**

Manner of transporting whale-bone on the vessels. (Sect. v, vol. ii, pp. 243. 244.)

[See explanation opposite.]

## Plate 191.

### DECK VIEW OF WHALE BOAT READY FOR THE CHASE.

[Scale  $\frac{1}{2}$  inch to foot. Parts of boats designated by figures and, utensils by letters.]

1, Bow-chocks through which tow-line runs when fast to a whale. 2, Lance straightener; a slot in gunwale for straightening bent irons. 3, 3, Top or false chocks, nailed on gunwhales. 4, Box of boat. 5, Chimsy-cleat or thigh thwart used by boat-steerer to steady himself during the capture. 6, Shackle or iron strap, for hoisting and lowering the boat to and from the ship. 7, 7, 7, Timbers of boat. 8, Platform (forward) upon which boat-steerer and officer stand when striking and working a whale. 9, 9, Risings, or top board of ceiling, on which the thwarts are placed and nailed. 10, Harpooner thwart. 11, 11, 11, 11, Knees on all thwarts. 12, 12, 12, 12, Dunnage for all thwarts; the main thwart (16) is dunnage all the way across. 13, 13, 13, Boat ceiling (inside planking); the bottom of boat. 14, 14, 14, 14, Peak cleats; wooden cleats for the reception of the handles of the oars when apeak; used when fast to a whale, when the oarsmen are resting, &c. 15, Peak cleat for tub-oar. 16, Bow thwart; a seat for the bow oarsman. 17, Mast-hinge and strap, showing mast-hinge block. 18, 18, 18, Sail-cleats. 19, Mid-ship thwart for mid-ship oarsman. 20, Center-board, box and well. 21, Gunwales. 22, Tub-thwart for tub oarsman. 23, After thwart. 24, Well for bailing boat. 25, Plug for letting water out of boat when on the cranes. 26, Platform (aft) on which officer and boat-steerer stand when steering boat. 27, Standing cleats upon which officer stands when going on to a whale in order to get a *longer view*. 28, Cuddy-board. 29, 29, 29, 29, Cuddy-boards; cedar boards filling up the stern of boat from the cuddy-board aft to stern-post. 30, Logger head strip, or *lion's tongue*. 31, Logger-head; an upright post with enlarged head, around the neck of which runs the tow-line when fast to a whale and by which the line is managed. 32, Boat-iron, or shackle, same as 6. 33, Rudder. 34, Tiller. 35, 35, 35, High and low rowlocks (wooden), with holes for the reception of shanks of rowlocks. 36, 36, Bow-cleats; nailed to gunwales, and used in *bowing on a whale*, and also as safeguard in case the tow-line should jump from bow-chocks and preventing it from sweeping the boat aft.

*A*, First iron, shank resting in bow-chocks and handle in boat-crotch. *B*, Second iron, placed in same position as first iron; the handle of first iron, which is the first instrument used, is placed in the top crotch; the handle of second iron is placed in the lower crotch; the extreme end of tow-line is bent in the eye of the first iron strap; these two irons are known as the live irons or live harpoons. *C, C*, Spare irons on port side of boat above thwarts (the two other spare irons, one on either side of boat under thwarts cannot be shown in this plan). *D, D, D*, Three lances (thrust by hand) on starboard side of boat, used in killing the whale. *E*, Boat spade on starboard side aft. *G*, Harpooner oar. *H*, Bow-oar. *I*, Mid-ship oar. *J*, Tub oar. *K*, Stroke-oar. *L*, Steering-oar, manipulated by officer of boat when going on to a whale. *M, M, M, M, M*, Paddles. *N*, Small tub with tow-line coiled down, containing 75 fathoms of line. *O*, Large tub with tow line coiled down, containing 225 fathoms of line. *P, P, P*, Tow-line extending aft from large tub around loggerhead and forward across the thwarts to box of boat (4), where it is coiled and known as box-warp (*PP*); thence extending to and bent in eye-splice of first iron strap. *Q, Q*, Mast and sail. *R*, Steering-oar brace. *S*, Lashing or strap for handle of steering-oar when not in use or fast to a whale.



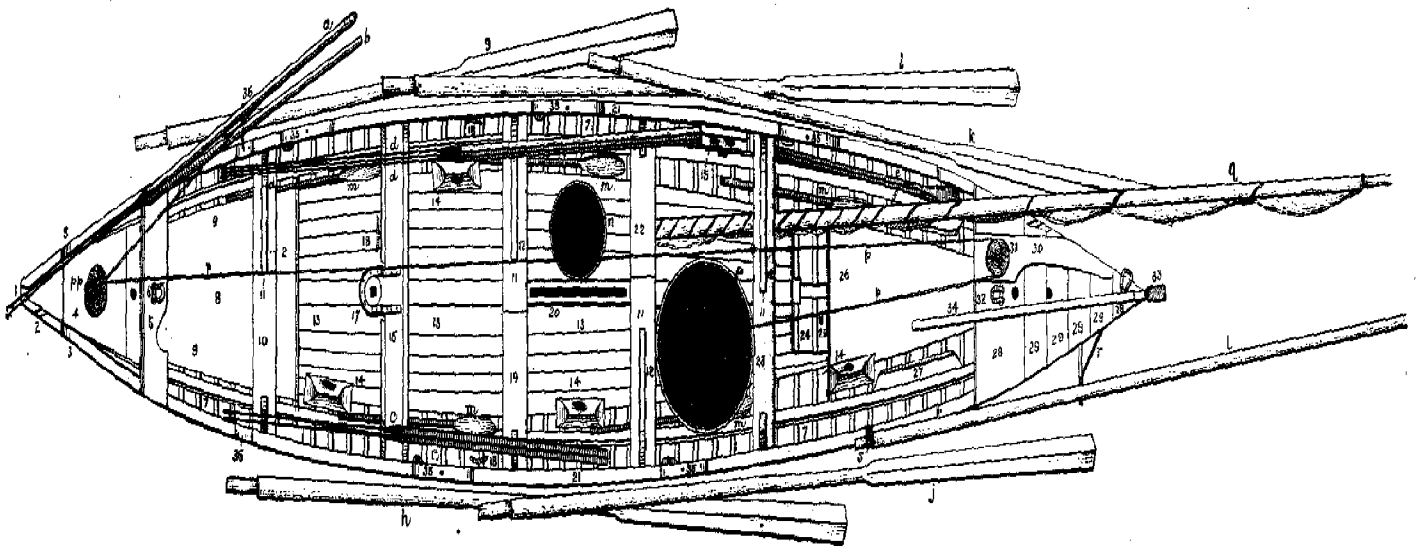

THE WHALE FISHERY.

Deck view of whale-boat ready for the chase; scale,  $\frac{1}{2}$  inch to foot. (Sect. v, vol. ii, pp. 241, 254.)

Drawing by C. S. Raleigh.

[For description, see opposite page.]

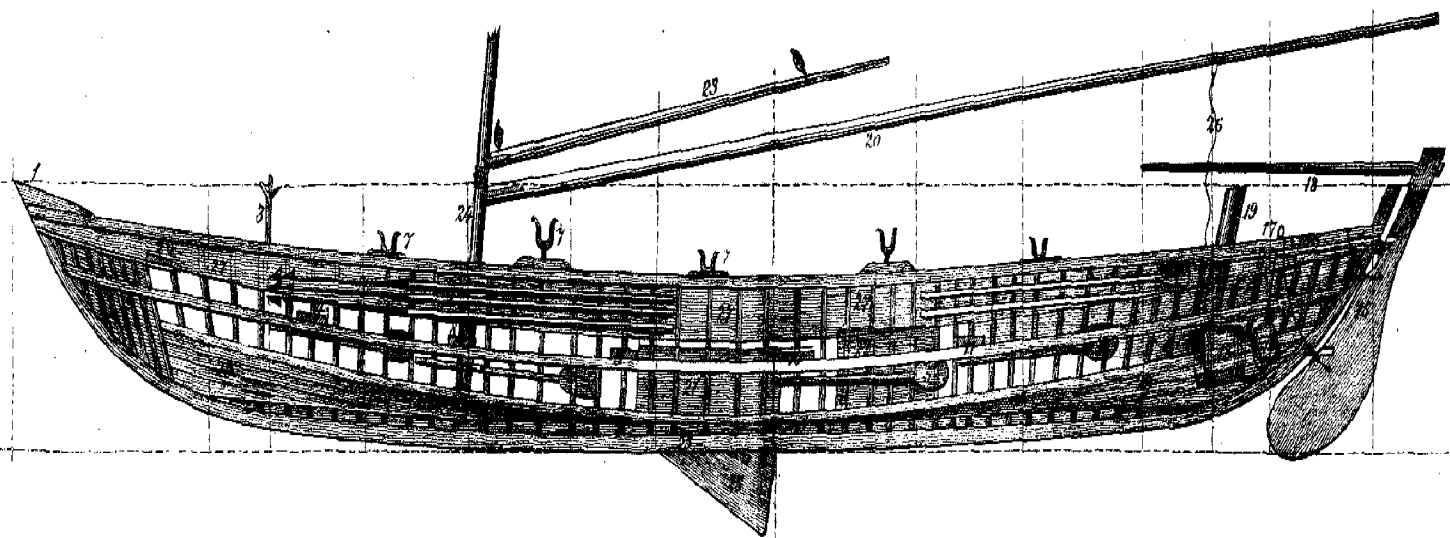

**THE WHALE FISHERY.**

Side and interior plan of whale-boat. (Sect. v, vol. ii, pp. 241, 258.)

Drawing by C. S. Raleigh.

[For description, see opposite page.]

## Plate 192.

### SIDE AND INTERIOR PLAN OF WHALE-BOAT,

Length, 30 feet.

1, Bow, chock, and roller. 2, Clumsy cleat, and hoisting eyebolt. 3, Crotch for bow harpoon irons. 4, Harpooner thwart. 5, Paddles. 6, Harpoon irons, lances on opposite side. 7, Rowlocks for oars. 8, Bow thwart. 9, Mid-ship thwart. 10, Tub thwart. 11, After thwart. 12, Boat spades and waifs (i. e., small flags to locate dead whale). 13, Lantern keg. 14, Piggins (for bailing boat, &c.). 15, Rudder. 16, Rowlock for steering, oar. 17, Hoisting eyebolt. 18, Tiller. 19, Loggerhead. 20, Boom for sail. 21, Center case (small tub for 75 fathom-line other side). 22, Large tub for whale line, 225 fathoms. 23, Gaff for sail. 24, Mast for sail. 25, Keel and floor timbers. 26, Main sheet. 27, Gunwale streak plank, 9 inches in widest part, generally colored blue in new boats. Timbers of boat of this size, about 6 inches apart (generally). 28, Center-board partly down. 29, Boat's ceiling.

NOTE.—Oars omitted on this draft, full length being given on front and interior plan.

## Plate 193.

### ARTICLES OF WHALE-BOAT GEAR.

- FIG. 1, Lantern keg containing matches, bread, tobacco, &c.
- FIG. 2, Compass.
- FIG. 3, Keg for fresh water.
- FIG. 4, Piggin for bailing.
- FIG. 5, Waif for signaling.
- FIG. 6, Tub-oar crotch, ships through cleat in gunwale, to clear oar from the line when fast to whale.
- FIG. 7, Double oar-lock used when propelling the boat and for same as tub-oar crotch.
- FIG. 8, Large line in line-tub.
- FIG. 9, Knife for cutting line when foul.
- FIG. 10, Rowlock.
- FIG. 11, Hatchet for cutting line, cutting poles out of whales, &c.
- FIG. 12, Grapnel for catching line.
- FIG. 13, Drag, or drug, for bending on drug iron to retard movements of whales.
- FIG. 14, Canvas nipper to protect hands when handling line.

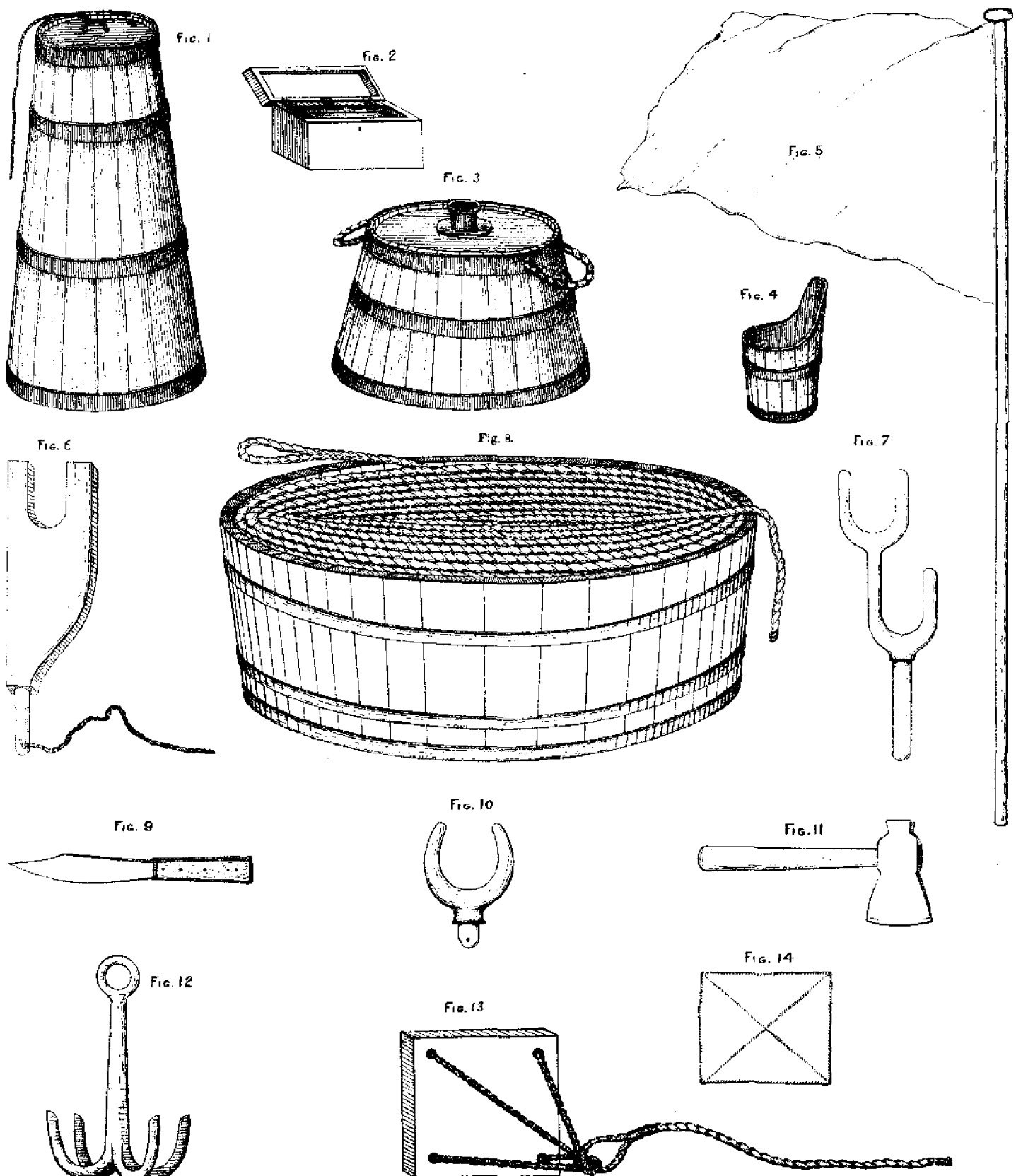

**THE WHALE FISHERY.**

Articles of whale-boat gear. (Sect. v, vol. ii, pp. 240, 252.)

[See explanation on opposite page.]

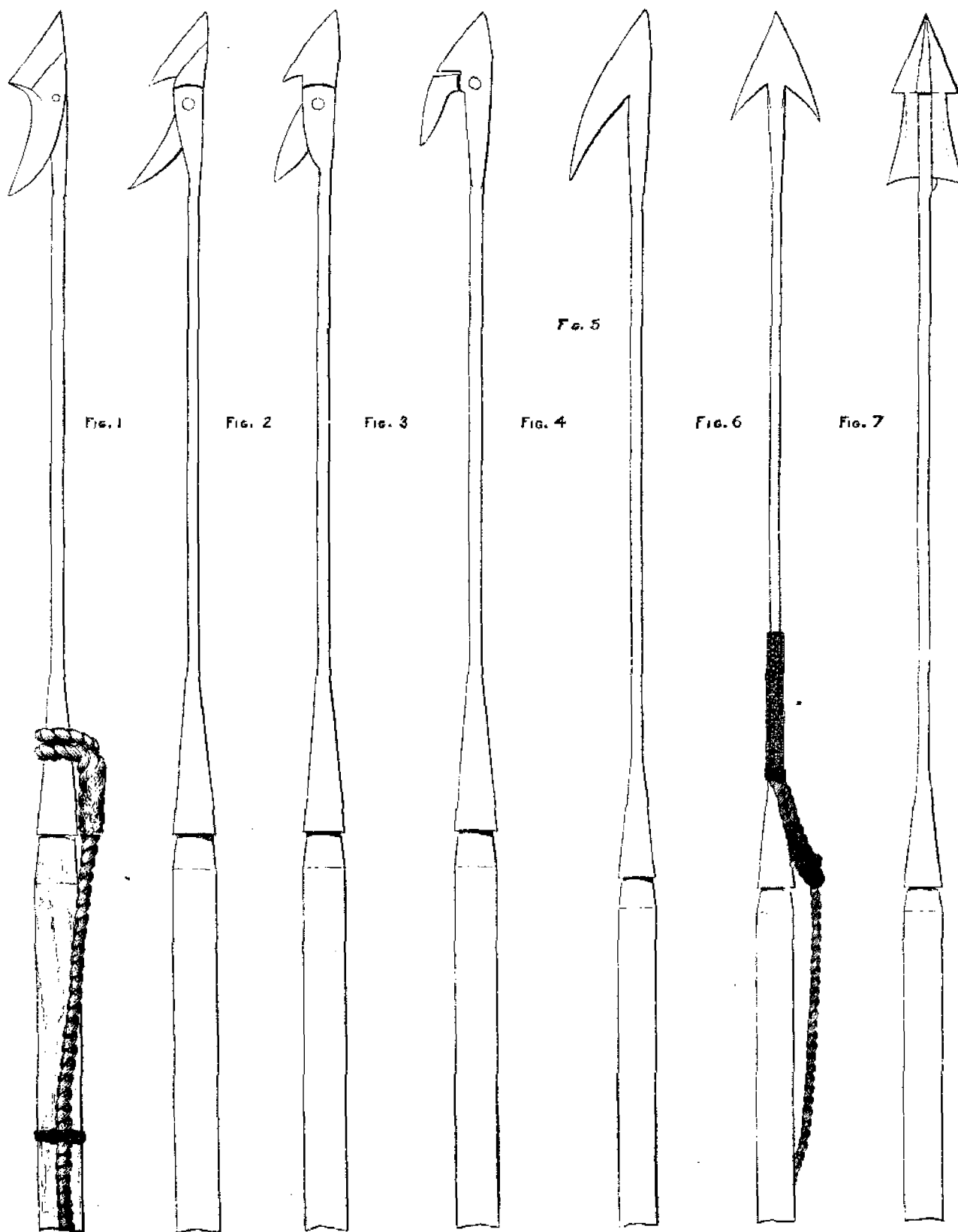

**THE WHALE FISHERY.**

Harpoons. (Sect. v, vol. ii, p. 250.)

FIG. 1. Improved harpoon or toggle-iron now in general use.  
 FIGS. 2, 3. First forms of toggle-irons made by Lewis Temple.  
 FIG. 4. "One-flued" harpoon with hinged toggle.

FIG. 5. "One-flued" harpoon.  
 FIG. 6. "Two-flued" harpoon.  
 FIG. 7. Provincetown toggle-iron; not now in use.

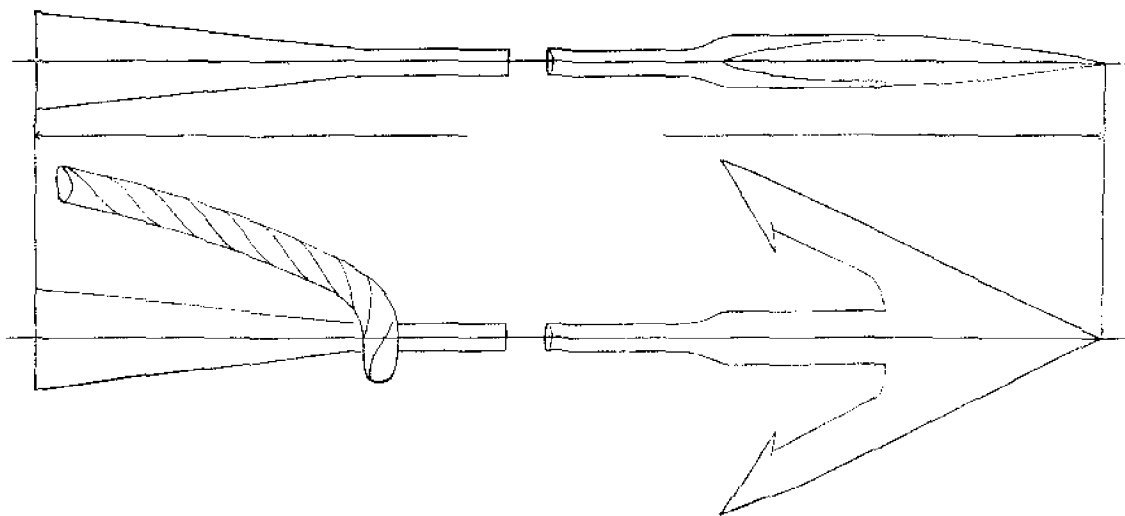

Fig. 1.

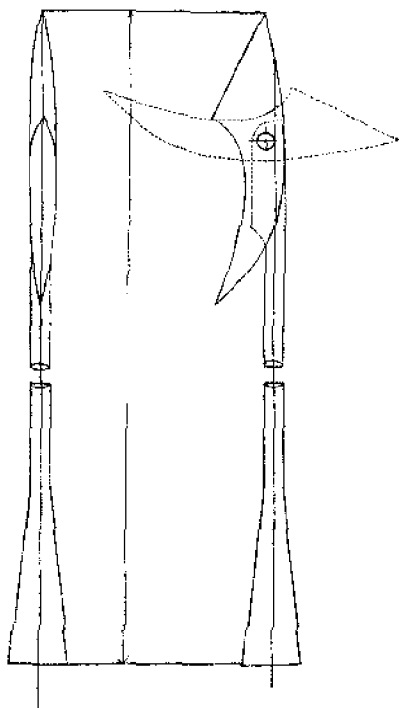

Fig. 2.

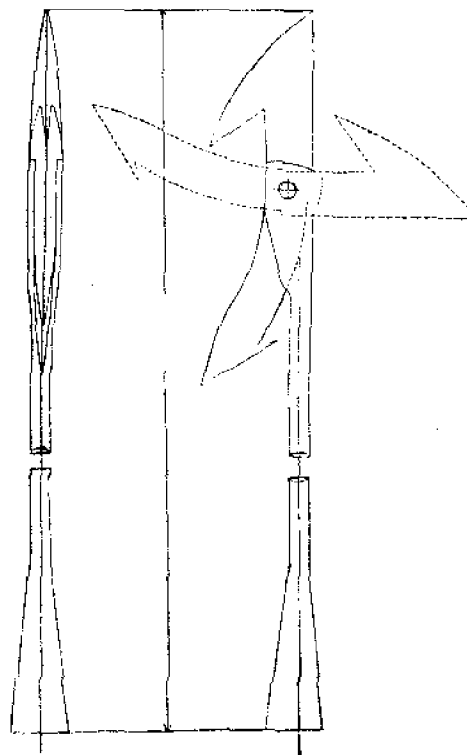

Fig. 3.

### THE WHALE FISHERY.

English harpoons. (Sect. v, vol. ii, p. 250.)

FIG. 1. Old style of hand-harpoon now little used.

FIG. 2. Hand-harpoon in general use about 1857.

FIG. 3. Hand-harpoon now most in use on the Scotch whaling steamers.

Drawings by Capt. William Adams, of Dundee, Scotland.

## Plate 196.

### WHALING GUNS.

FIG. 1, English harpoon-gun and gun-harpoon now in use on the Scotch whalers.

FIG. 2, An early form of English whaling-gun.

FIGS. 3, 4, 5, Mason and Cunningham mounting boat-gun.

Fig. 3 is a perspective of the gun mounted in the bow of the whale-boat, ready for use; Fig. 4 is a top view of the gun and the casting C and trunnions; and Fig. 5 is a sectional view of the box E, which is fixed in the clumsy cleat B of the boat A, at E. In Fig. 5 the parts *e* and *f* are of metal, and *d'* is of some elastic substance. The gun is mounted at C on the standard D, which passes through the cushion-blocks E and enters the floor at D'. In Fig. 4 *dd* are the trunnions, which are supported by the slides *a, a*. Rubber cushions *d, d* are placed around the slides *a, a* and at the rear of the trunnions *d, d*. The operation of the apparatus is as follows: The harpoon H, with line *o'* attached, is loaded into the muzzle. When the gun is fired, the force of the recoil is caught on the cushions *dd*, shown in Fig. 4, and partially by the cushion in box E, Fig. 5, thus converting the sudden blow of a recoil into a push.



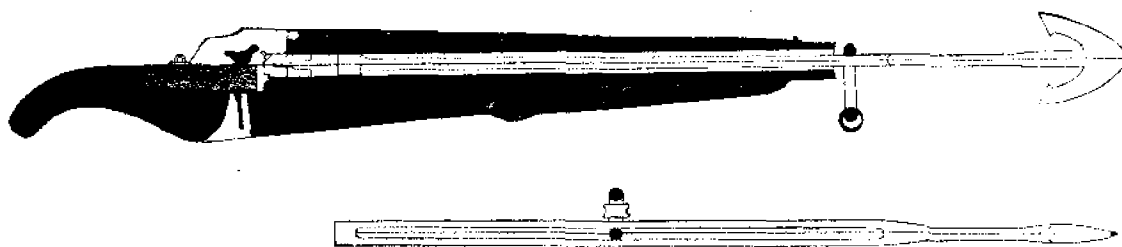

Fig. 1.

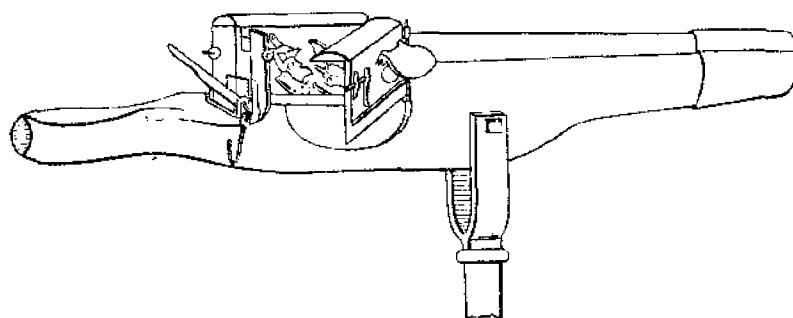

Fig. 2.

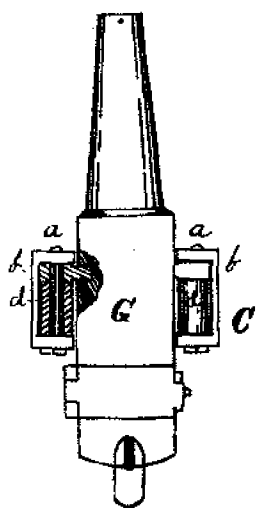

Fig. 4.

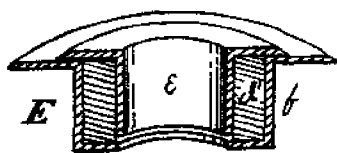

Fig. 5.

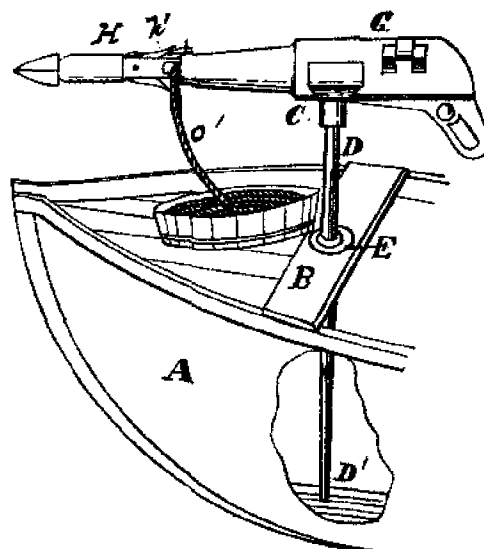

Fig. 3.

### THE WHALE FISHERY.

English and American swivel guths. (Sect. v, vol. ii, p. 252.)

[See explanation on opposite page.]

## Plate 197.

### DARTING AND SHOULDER GUNS.

FIG. 1. Pierce and Cunningham darting gun and bomb-lance. A combined harpoon and lance used largely by Arctic whalers.

*a.* Gun-metal barrel about 20 inches long.

*B.* Ordinary harpoon pole, fitted into brass socket (*c*).

*b.* Breech-pin and lock-case.

*C.* Harpoon with whale-line (*E*) attached; and set in projections (*d, d*) on the gun.

*d.* Bomb-lance fired from barrel (*a*).

The harpoon entering the blubber brings the long wire rod (*g*) in contact with the whale and releases the trigger.

*F.* Lever for cocking the gun.

*h.* Line by which the gun is hauled back to the boat.

Improved forms of darting guns have since been invented and will be illustrated in the Section on APPARATUS OF THE FISHERIES.

FIG. 2. Cunningham and Cogan gun; length, 33 inches; weight, 27 pounds. Used by Arctic steam whalers with bomb lance.

FIG. 3. Brand muzzle-loading whaling-gun (*a*) and bomb-lance (*b*).

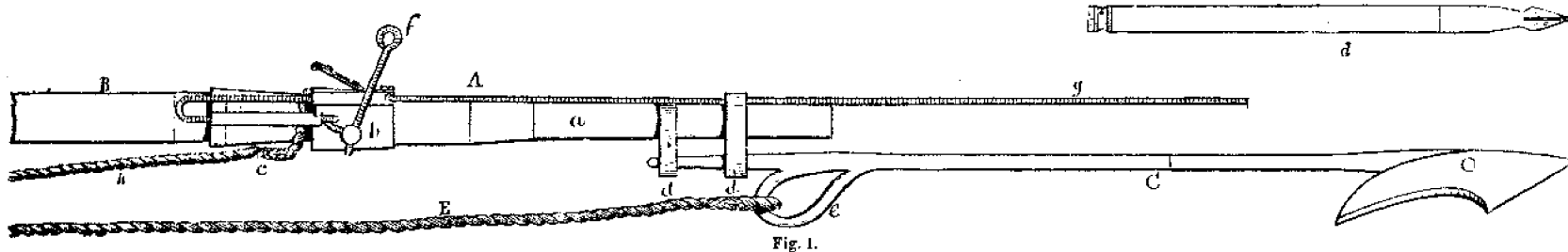

Fig. 1.

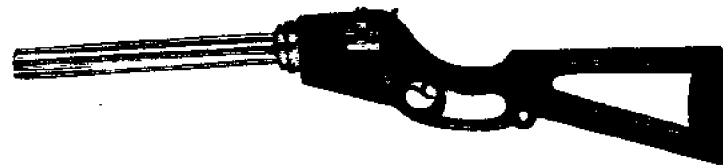

Fig. 2.

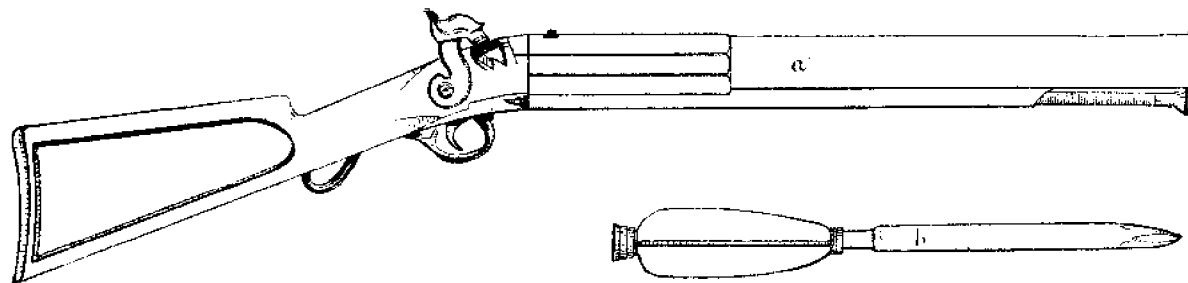

Fig. 3.

**THE WHALE FISHERY.**

1, Darting gun. 2, Cunningham and Cogan gun. 3, Brand muzzle-loading bomb-gun. (Sect. v, vol. ii, pp. 253, 254.)

[See explanation on opposite page]

## Plate 198.

### BOMB LANCE AND BREECH-LOADING WHALING-GUN.

Figs. 1, 2, 3, 4 The Pierce bomb-lance. The figures illustrating the lance are from the drawings accompanying the specification of the patent, and the significance of some of the letters will not be explained here. Fig. 1 shows the lance with the wings (C) closed by a metal ring showing the arrangement when the implement is loaded in the gun. Fig. 2 represents the lance with wings expanded, the true position during flight. Fig. 3 is a perspective view of the tail-piece with the wings open, and Fig. 4 a cross-section of the same showing the wings closed. The fuse is ignited by a percussion cap. The cap is placed on the nipple (E, Fig. 1) of the fuse tube (D) backward through the fuse-plug and communicates with the magazine (A). A metallic hammer or plunger (H) is held by a wooden pin (G). The concussion of the explosion of the charge when the gun is fired breaks the pin and releases the hammer, which, violently striking the percussion cap, explodes it and fires the fuse.

Fig. 5. Pierce and Egger's breech-loading gun; length,  $36\frac{1}{2}$  inches; weight, 24 pounds. The gun in most common use.

"To load the gun the lever (c) is raised, the thumb inserted at aperture (d), and the breech-block thrown down to a, when the cartridge can be readily inserted, the bomb-lance having previously been placed in the barrel from the muzzle. The breech-block is then raised and the gun is ready for use."

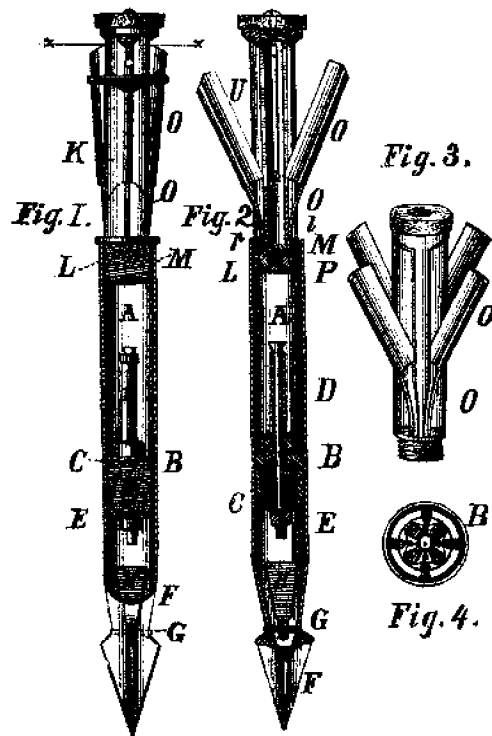
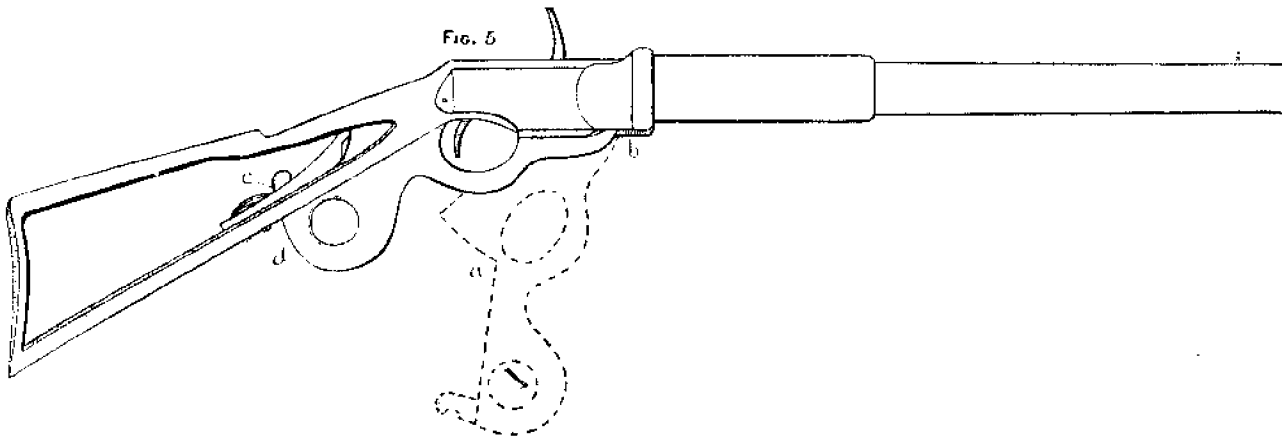

**THE WHALE FISHERY.**

Pierce and Egger's breech-loading bomb-gun and Pierce bomb-lance. (Sect. v, vol. ii, p. 253.)

[See explanation on opposite page.]

## Plate 199.

### WHALING ROCKET.

Figs. 1, 2, 3. The projectile consists of a cast-iron shell (Fig. 2), and a rocket with a loop extension (Fig. 3). The shell, 15 inches long, has been detached to show the toggle, which is fastened by two links to the projecting end or shoulder of the rocket. The bomb is filled with peculiar composition said to be known only to the inventors. The rocket is made of brass and the loop extension (*bb*) of wrought-iron; the total length is 66 inches, and the length of the toggle (*a*) about 10 inches. When the bomb with its rocket attachment (Fig. 3) is loaded in the gun (Fig. 3) which is partially supported by a standard (*b*), the link (*g*), with the tow-line (*f*) attached, hangs from the muzzle. The two rods projecting in the rear fastened to the iron plate, form the hinder part of the gun. The adjustable flange (*a*) occupies a position parallel to the gun when the gunner takes aim. The fire is communicated to the combustible material in the rocket-chamber by means of a pistol (*d*) and the issue of gas from the rear of the rocket propels the apparatus. During its flight the shackle (*g*) and the tow-line (*f*) take the position shown in Fig. 3. When the bomb explodes in the whale the toggle (*a*) and chain are released and fasten in the blubber or flesh, preventing the withdrawal of the apparatus. Simultaneously with the discharge of the gun, the flange (*a*) is thrown up in a vertical position following the path, as represented by the dotted lines (*cc*), to protect the eyes of the gunner. We shall have occasion to again refer to this apparatus in the account of shore whaling on the Northwest coast.

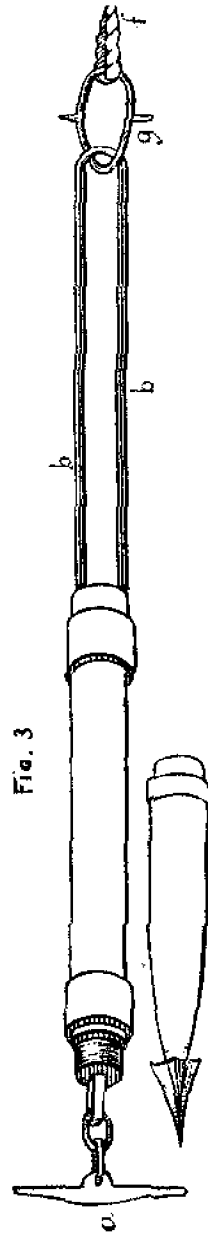
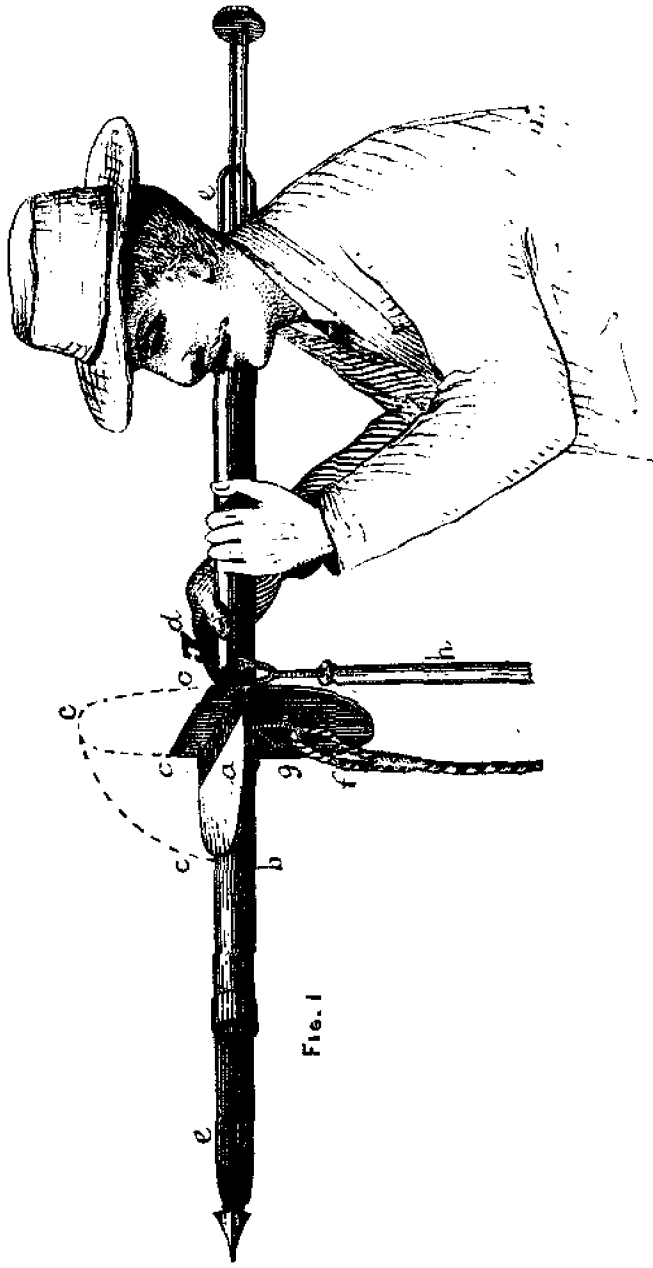

Fig. 3

**THE WHALE FISHERY.**

Whaling rocket. (Sect. v, vol. ii, p. 254.)

[See explanation on opposite page.]



THE WHALE FISHERY.

Boat fastened to whale by harpoon and line: killing the whale with bomb-lance. (Sect. v, vol. ii, pp. 45, 252, 257.)

From painting by J. S. Ryder.



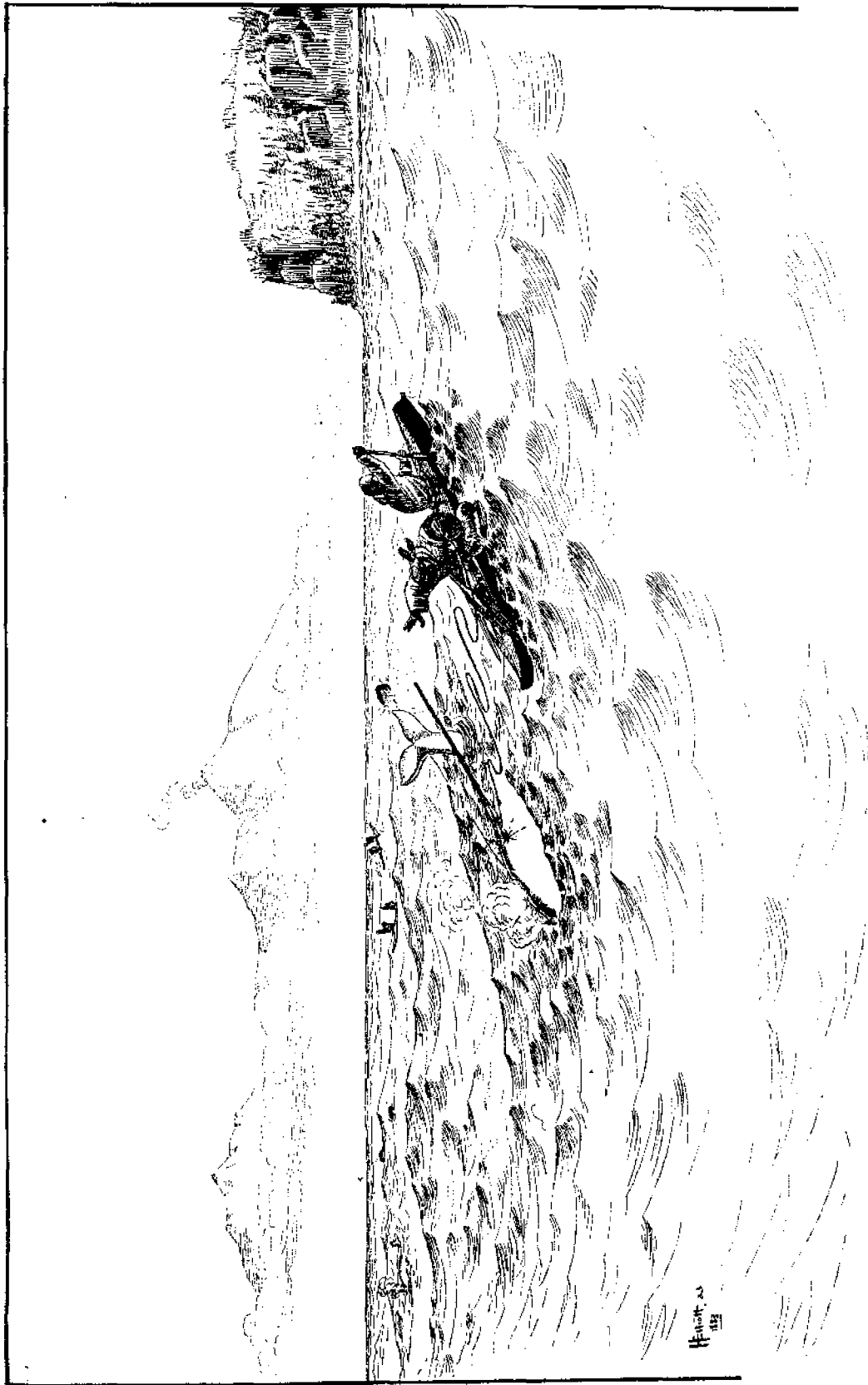

**THE WHALE FISHERY.**

Natives hunting the beluga or white whale, Cook's Inlet, Alaska. (Sect. v, vol. ii, p. 61.)

Drawing by H. W. Elliott.

H. W. Elliott  
1899

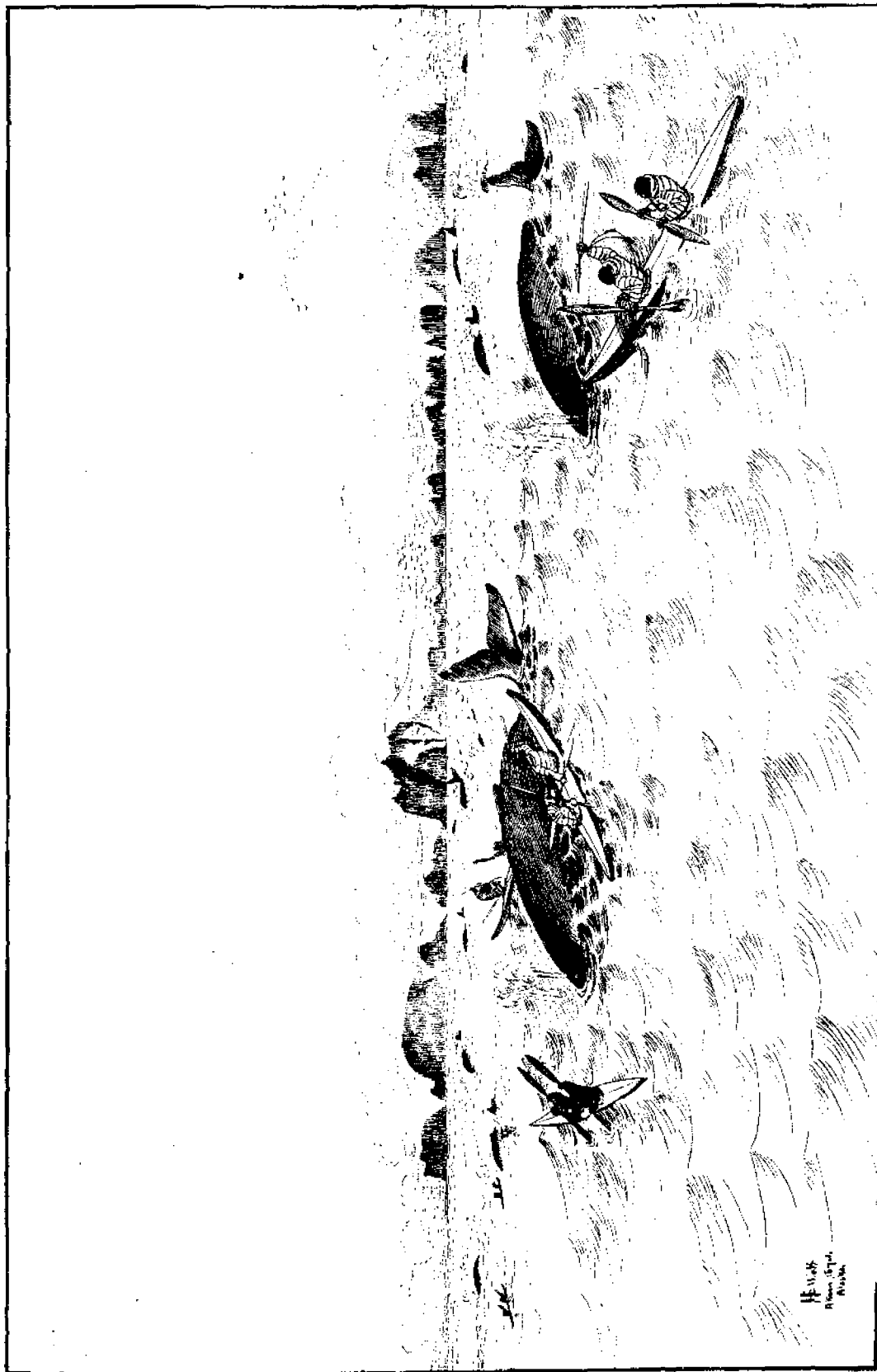

**THE WHALE FISHERY.**

Aleuts planting glass, obsidian, and jade darts in a school of humpback whales, Akun Island, Bering Sea. (Sect. v, vol. ii, pp. 61, 62.)

Drawing by H. W. Elliott.

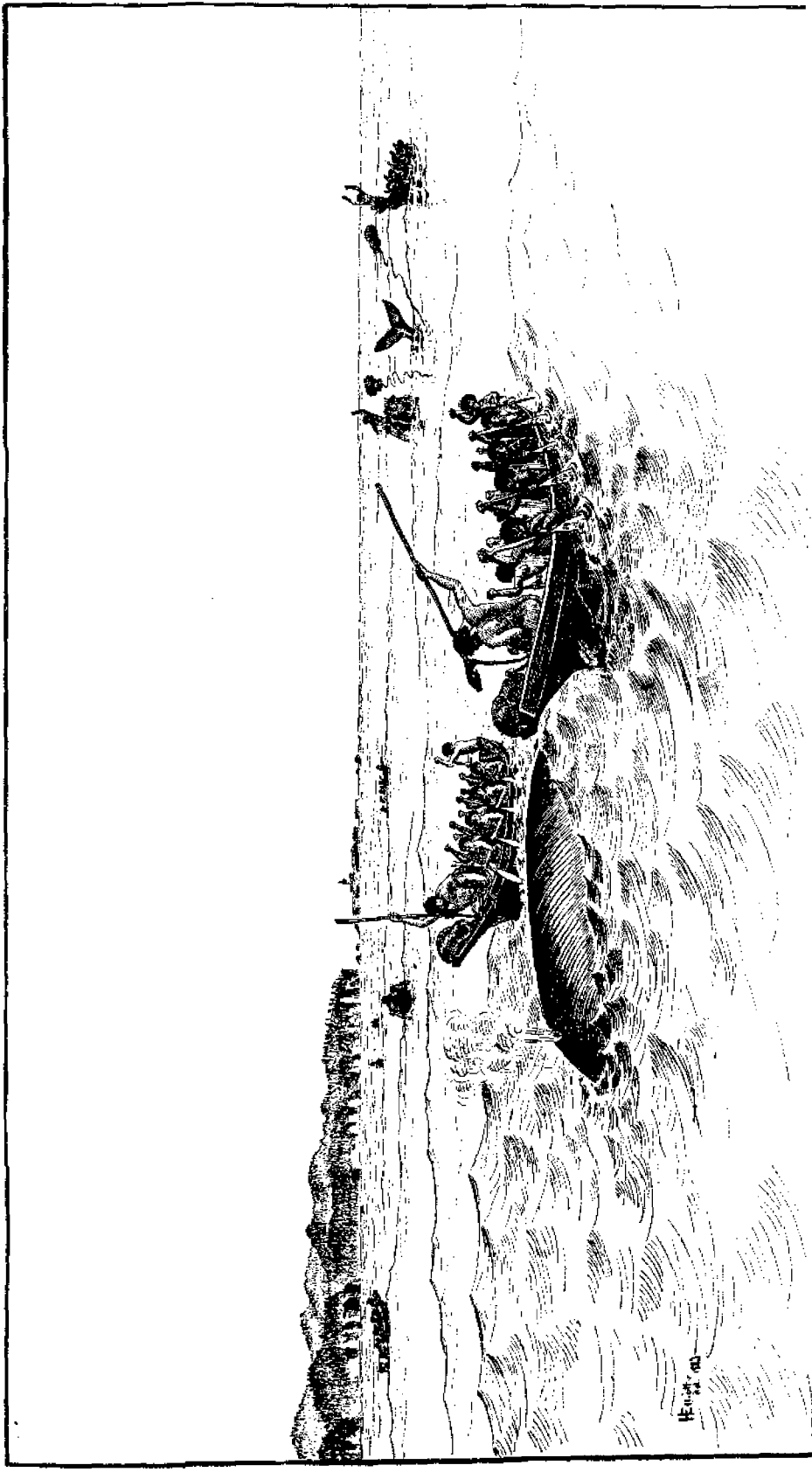

Cape Flattery. Tuboah Lobb.

**THE WHALE FISHERY.**

Makah Indians whaling at entrance to Puca Straits. (Sect. v, vol. ii, p. 62.)

Drawing by H. W. Elliott.

## Plate 204.

### CUTTING IN THE BOWHEAD AND SPERM WHALE.

(Vol. II, pp. 277-286.)

FIGS. 1, 2. Diagram of bowhead whale.

- A. Fluke-chain adjusted around the "small" and leading to windlass-bits.
- B. Fin-chain fastened around the left fin.
- C. Ring of fin-chain into which blubber-hook is fastened to raise fin and blanket piece—the starting-point for unwinding the blubber from the whale.
- D. Hole in root of lip into which blubber-hook is inserted to hoist lip on board ship.
- F to G. Scarf to detach and hoist lower lip.
- E to H. Scarf cut from fin below and forward of eye to spout-holes (H) on head.
- E to I. Scarf from fin (E) aft to back of whale (I).
- J to K. Scarf cut in removing blubber while whale is being rolled. The remaining spiral lines indicate final scarfs.
- L. Mortised hole in top of head for head-chain.
- M. The old method of hoisting head by the old head-chain and foggie, the chain being rove through the spout-holes.
- M. M. Figure (2) the new method of hoisting in head of whale by the use of the chain-strapped blocks. Tail of chain rove from H under several feet of blubber to and through the mortised hole at L and coupled to sister-hooks (on lower block).
- N. Cutting made by monkey, with the ax, while overboard, in order to detach the head-bone.
- O. The lower part of the bone, which, being very thin, requires light strokes in order to detach it.
- P. Markings showing where the flat-shanked spade is inserted to start the throat-bone in detaching the head.
- Q. Showing (approximately) where the hole is made in the throat in order to haul it on board by the present method.
- R. Dotted lines showing the throat-chain, and toggle and the former method of taking in the throat.
- S. Dotted lines showing where the backbone of whale is severed when taking off blubber in order to lessen the strain on the windlass.
- T. Wide section of blanket piece which is trimmed down by the boarding-knife when boarding blubber.

FIG. 3. Diagram of sperm whale showing method of cutting in. (Further description will be found in the chapter on oil rendering in the Section on PREPARATION OF FISHERY PRODUCTS.)

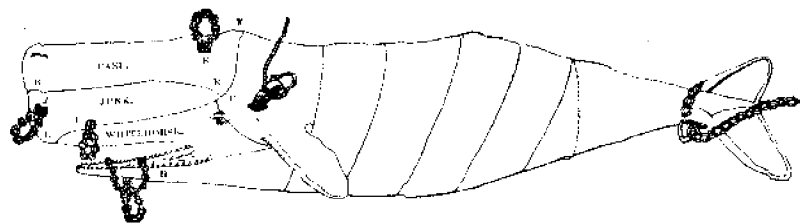

Fig. 3.

Fig. 2

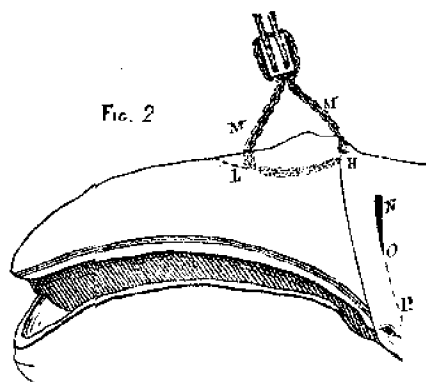
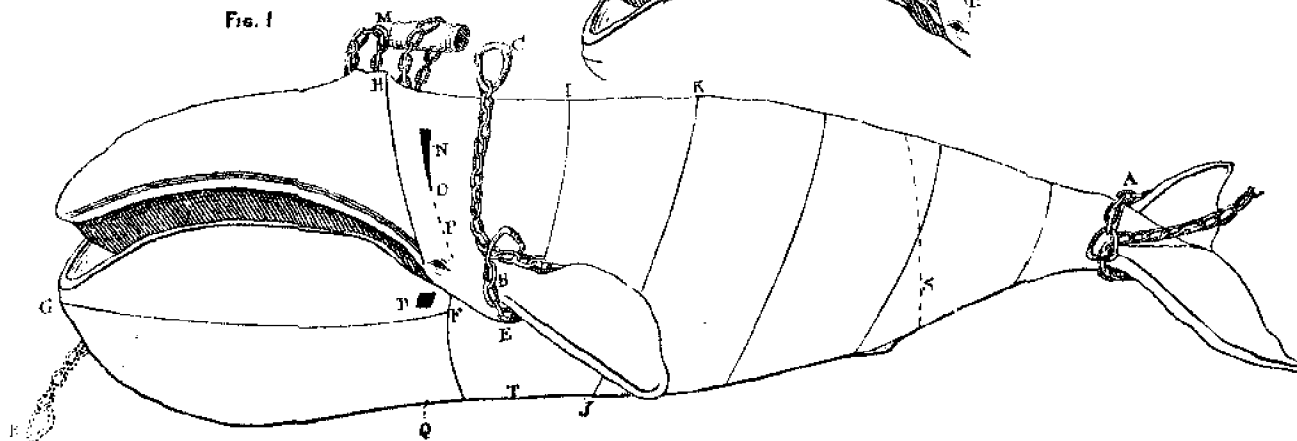

Fig. 1



### THE WHALE FISHERY.

Diagram of bowhead and sperm whales, showing methods of cutting in. (Sect. v, vol. ii, pp. 277-286.)

Drawings by Capt. C. M. Scammon and Capt. W. M. Barnes.

[See explanation on opposite page.]

## Plate 203.

### BOAT SPADE AND CUTTING SPADES.

(Vol. II, pp. 264, 277, 281.)

- FIG. 1. Boat spade (*b*) and sheath (*a*); formerly used to disable a running whale.  
FIG. 2. The narrow-cutting spade or thin boat-spade.  
FIG. 3. The flat or round shank spade used to cut a passage for the "head-strap" to hoist in the head of the right whale or bowhead, and to remove the throat-bone (whalebone).  
FIG. 4. Cutting spade for "scarfing."  
FIG. 5. Cutting spade for "leaning up."  
FIG. 6. Half-round spade.

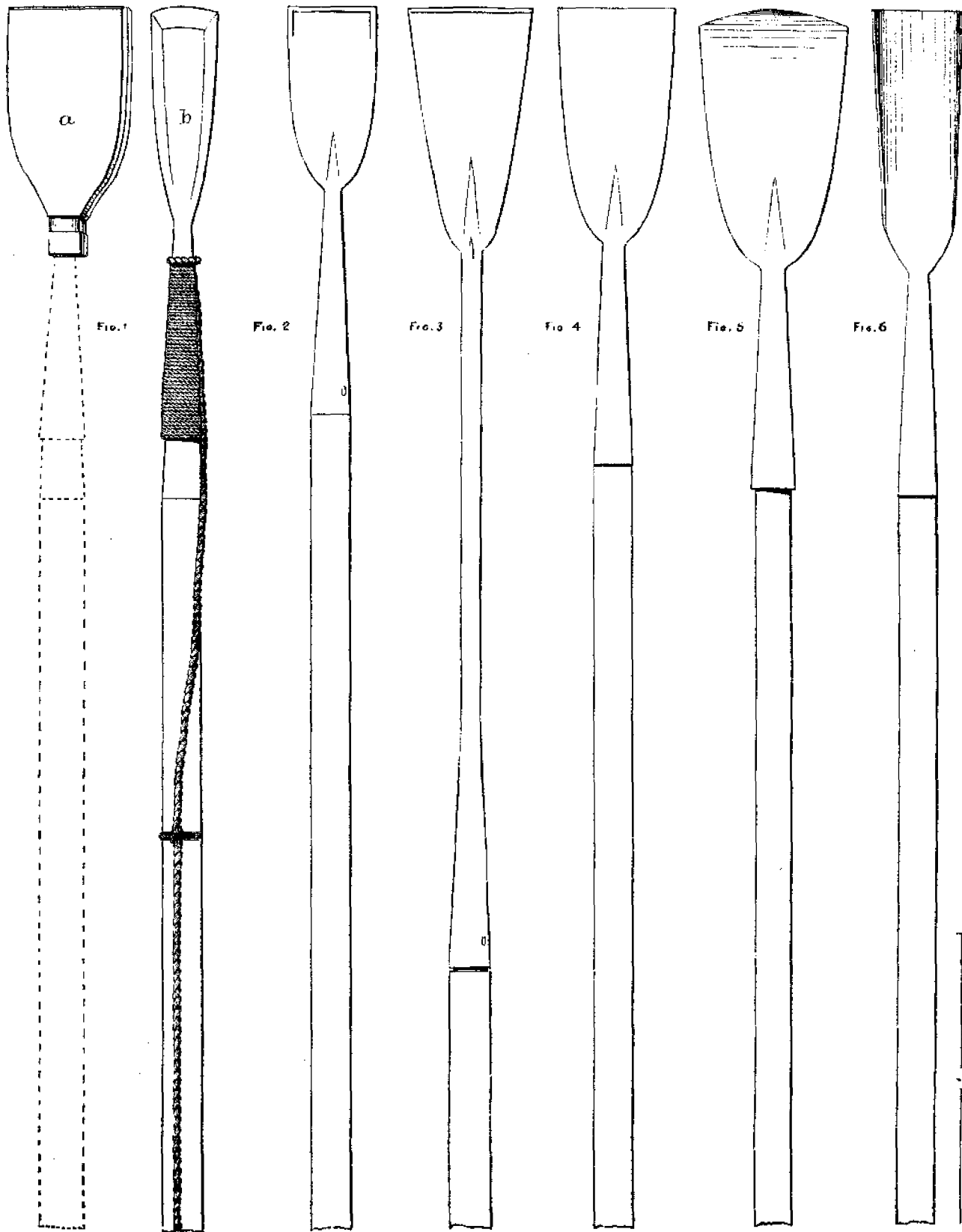

**THE WHALE FISHERY.**

Boat-spade and cutting-spades. (Sect. v, vol. ii, pp. 264, 277, 281.)

[See explanation on opposite page.]

## Plate 206.

### CUTTING TACKLE USED IN CUTTING IN A WHALE.

(Vol. II, pp. 277-281.)

FIG. 1. Lower block strapped with rope (*a a a*), and blubber hook (*g*), shackled into the grommet (*d*). The rope beekets (*e e e*) are used for convenience in handling the block, and the back lashing (*h*) by the officer in directing the point of the hook into a hole in the blubber.

FIG. 2. Upper blocks (*b b*), guy block (*c*), pendant shackles (*a a*), and links.

FIG. 3. Lower block (*b*) strapped with chain (*d*) and sister hooks (*e*) into which the tail may be coupled by means of the link (*e*).

FIG. 4. Perspective view of cutting-tackle, showing the position it assumes when suspended from the mast-head. It should be guyed out by means of the guy-block and rope (*c*), and the end of the cutting-falls (*e*) should lead to the windlass.

FIG. 5. An implement called the small blubber hook, used to manipulate blubber on the vessel.



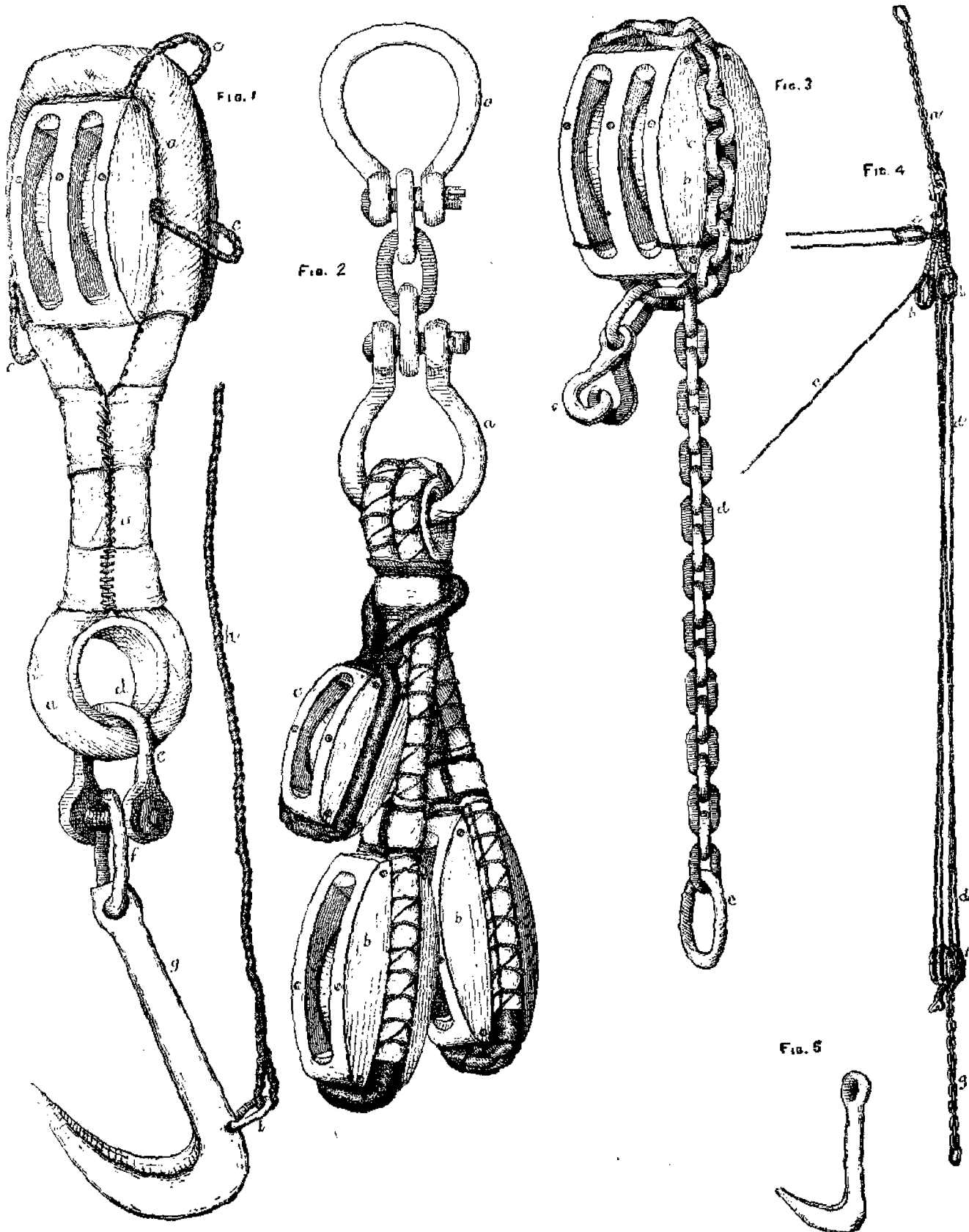

THE WHALE FISHERY.

Cutting-tackle used in "cutting in" the whale. (Sect. v, vol. ii, pp. 277-281.)

[See explanation on opposite page.]

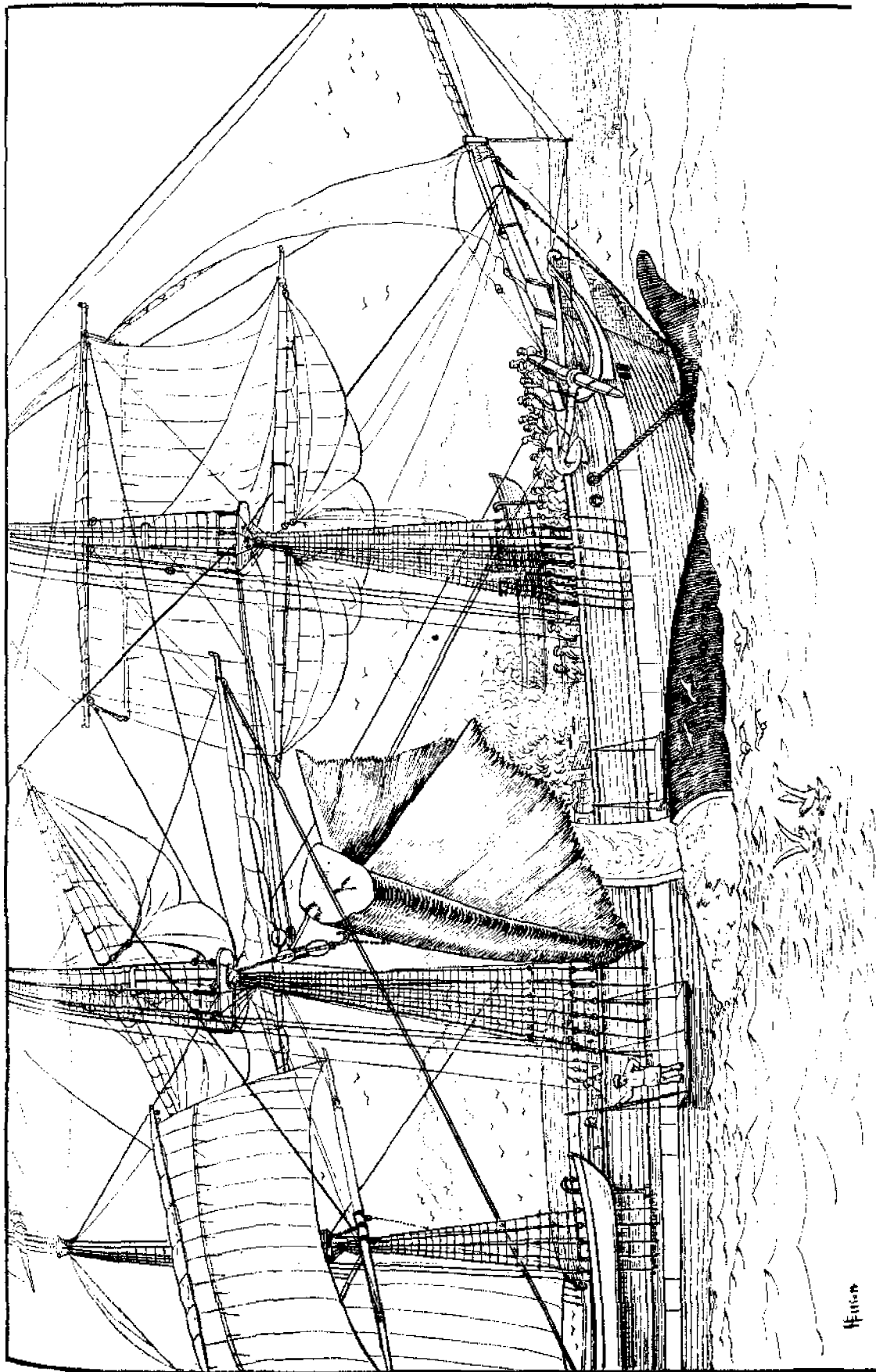

**THE WHALE FISHERY.**

"A ship on the Northwest coast of America cutting in her last right whale." (Sect. v, vol. ii, p. 277.)

Drawing by H. W. Elliott, from a French lithograph designed by B. Russell, of New Bedford.

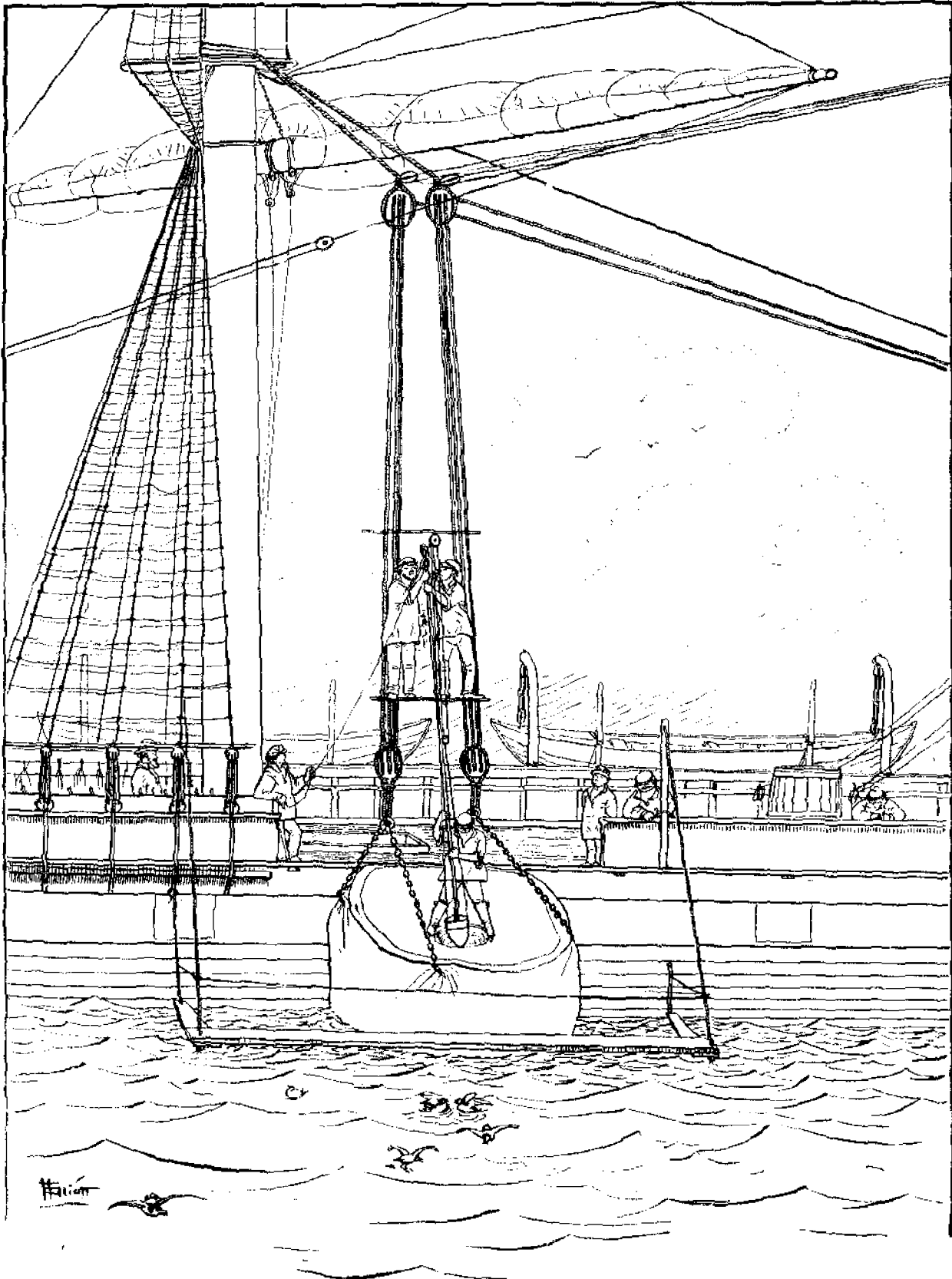

THE WHALE FISHERY.

"Bailing in the case" from head of sperm whale.

*Drawing by H. W. Elliott, from a French lithograph designed by B. Russell, of New Bedford.*

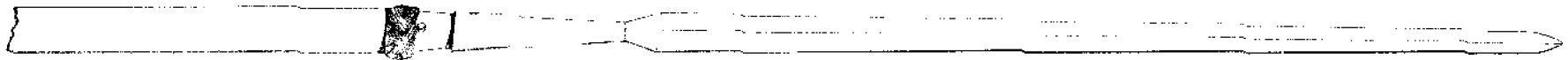

Fig. 2.

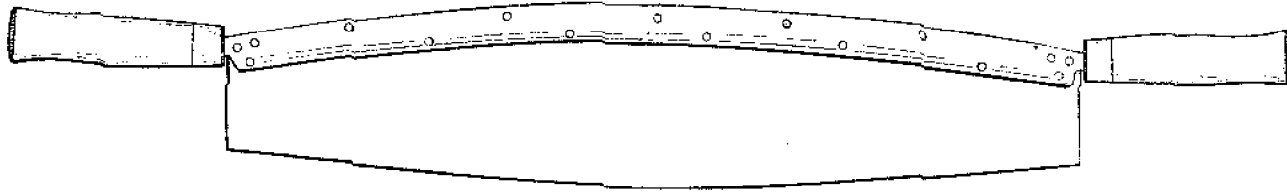

Fig. 1.

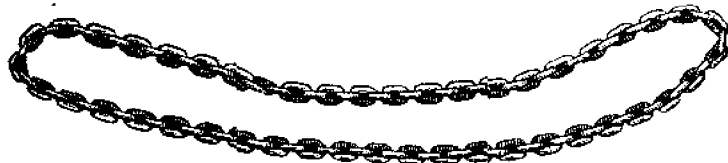

Fig. 5.

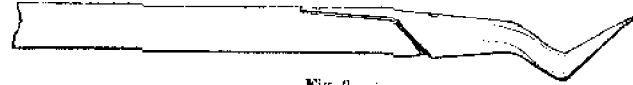

Fig. 9.

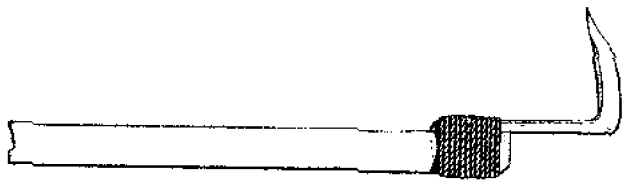

Fig. 3.

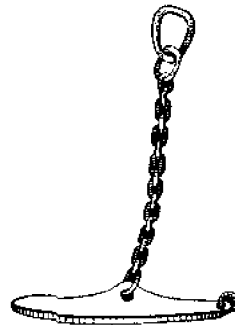

Fig. 6.

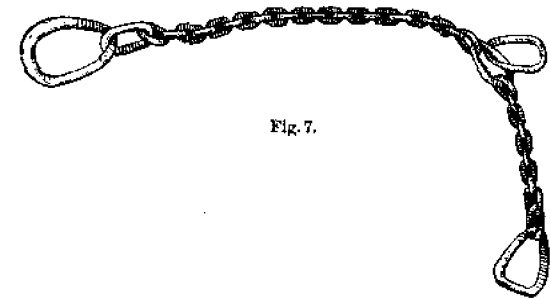

Fig. 7.

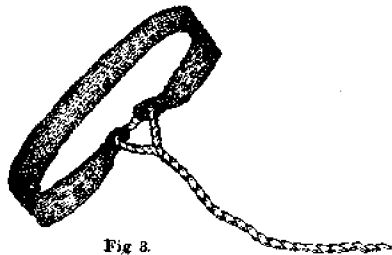

Fig. 8.

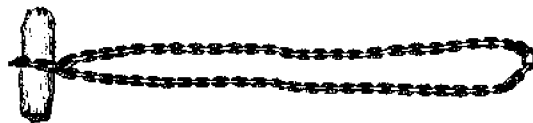

Fig. 4.

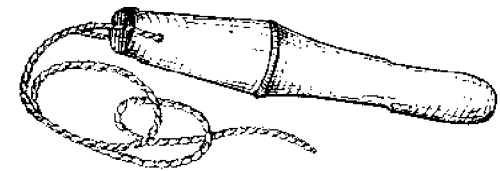

Fig. 9.

### THE WHALE FISHERY.

- FIG. 1. Blubber-mincing knife.
- FIG. 2. Boarding-knife.
- FIG. 3. Monkey-belt.

- FIG. 4. Wooden toggle.
- FIG. 5. Chain strap.
- FIG. 6. Throat-chain.

- FIG. 7. Fin-chain.
- FIG. 8. Head-strap.
- FIGS. 9. Blubber-hooks.

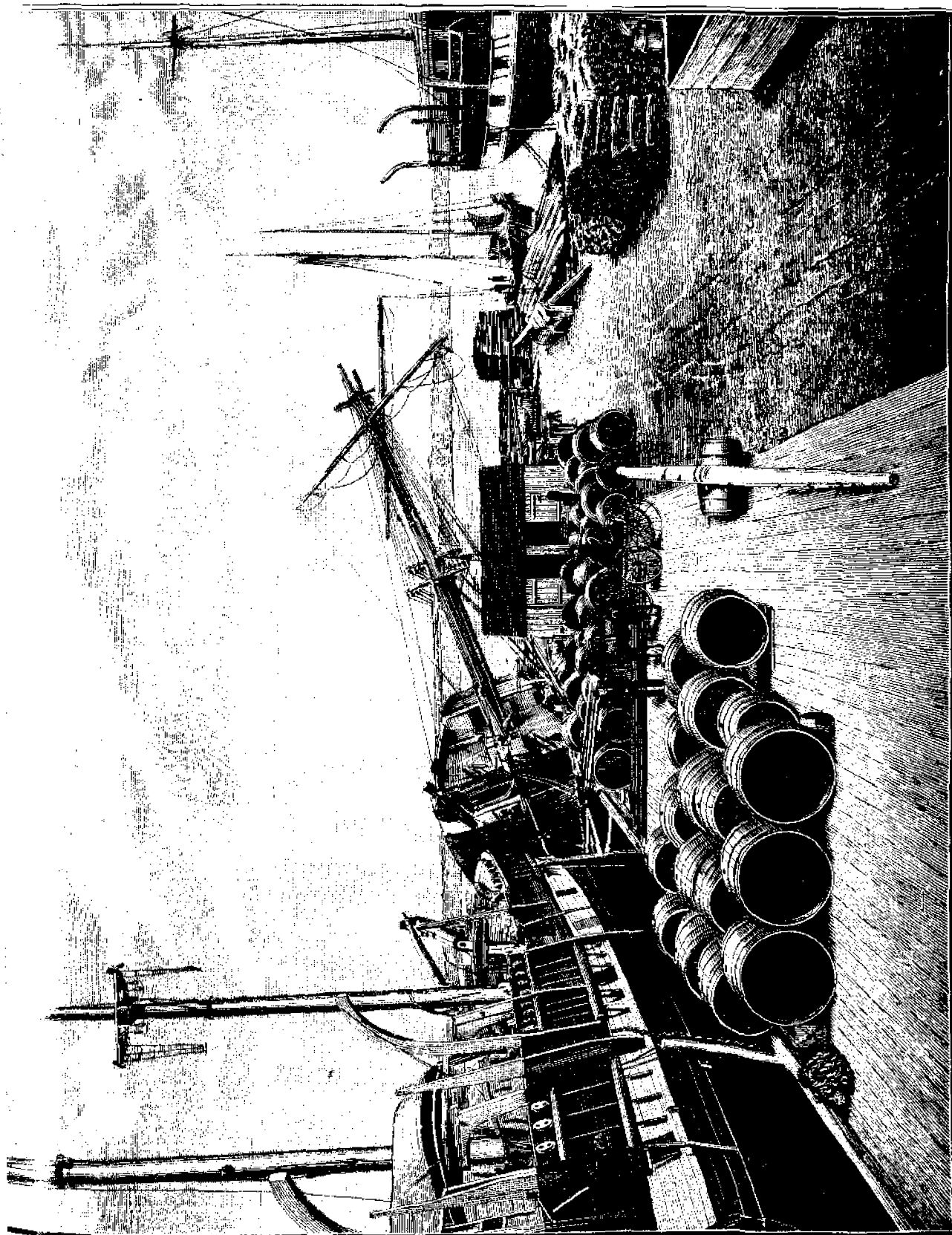

**THE WHALE FISHERY.**

Wharveships at New Bedford wharves; slip boxes down for repairs; oil-casks. (Sect. v, vol. ii, pp. 289, 290.)

From a photograph by U. S. Fish Commission.

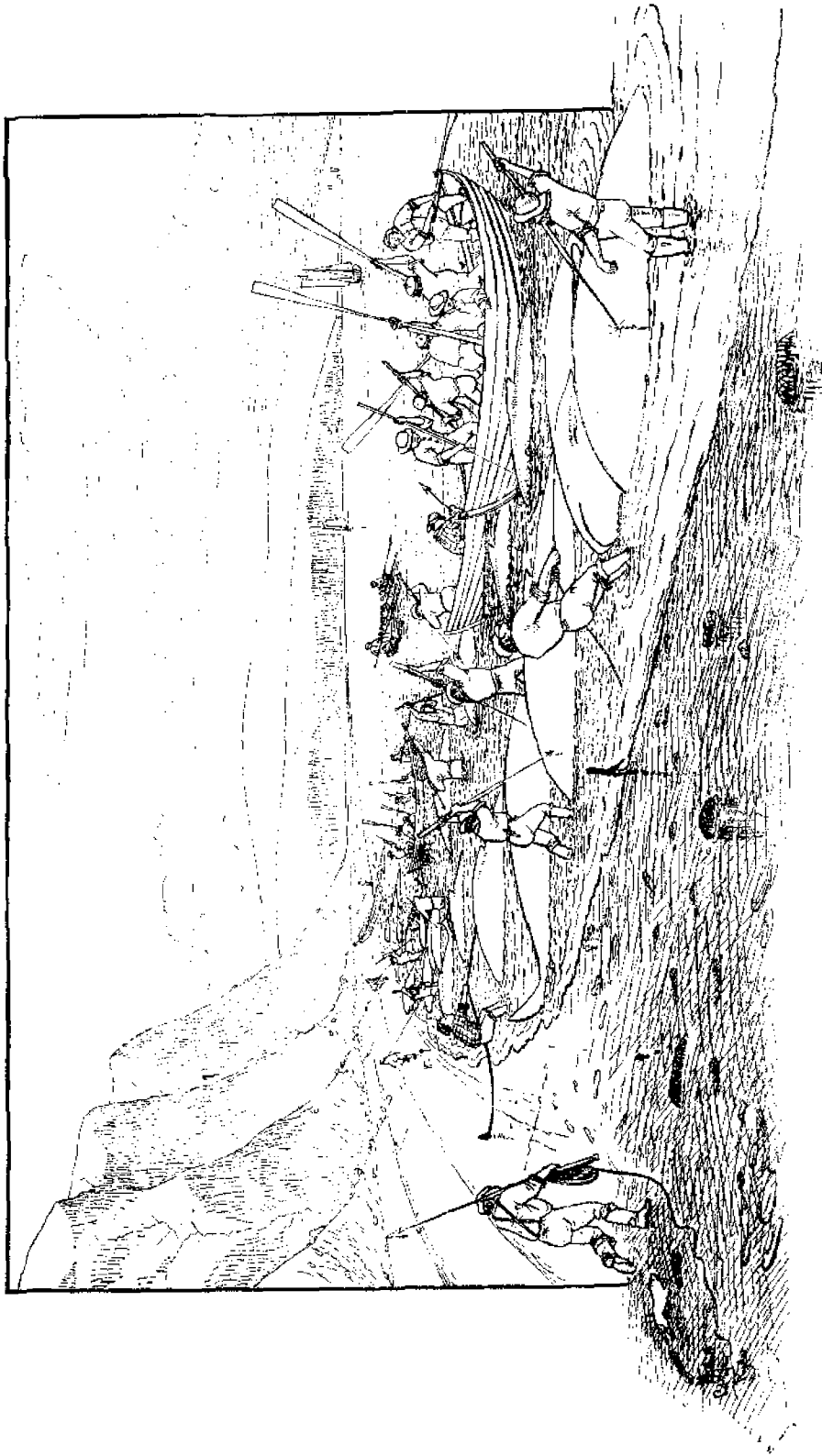

**THE BLACKFISH FISHERY.**

The capture of a school of blackfish in Cape Cod Bay. (Seal. N. vol. ii, pp. 205, 397.)

Drawing by H. W. Elliott, from a sketch by J. S. Ryder.

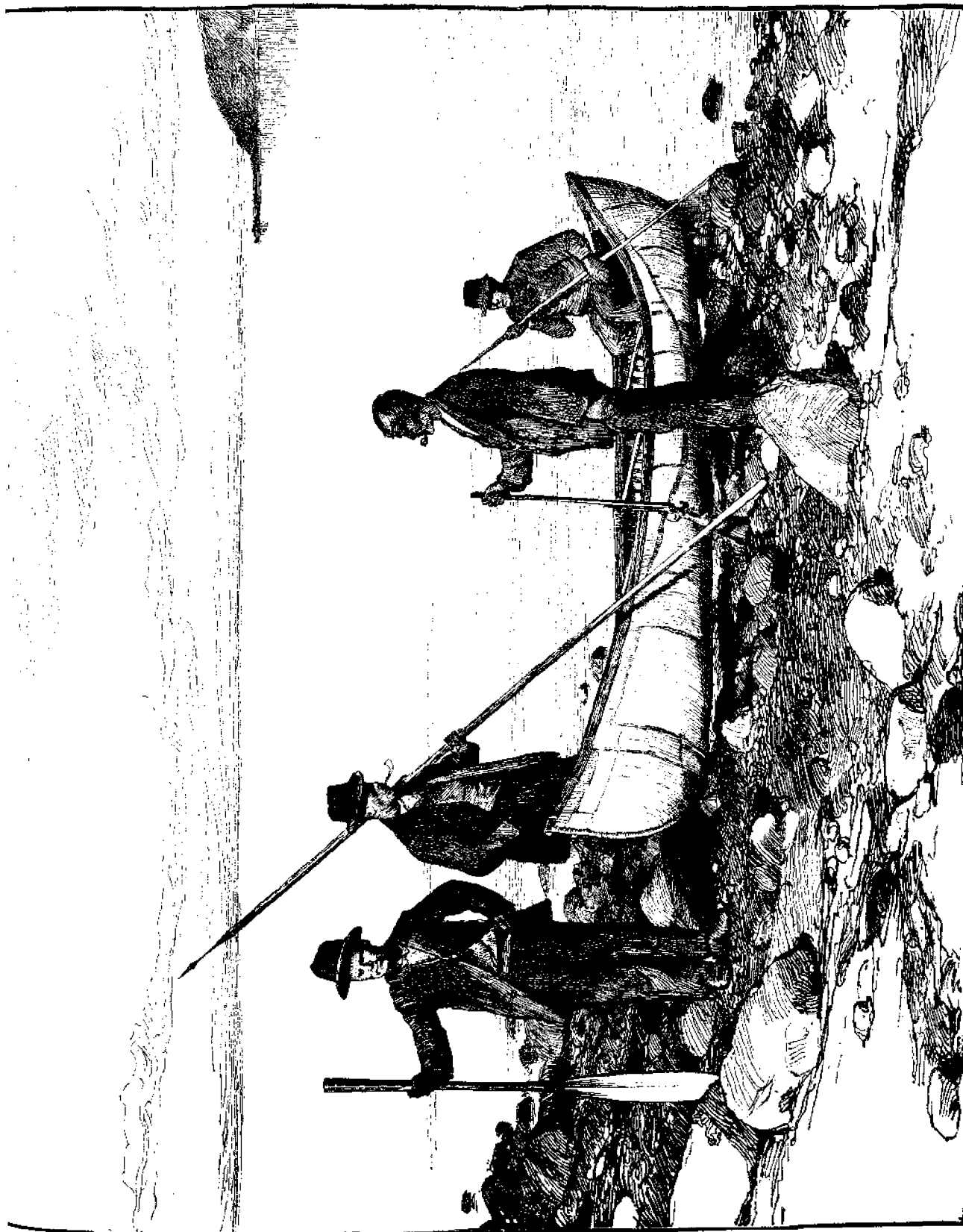

**THE PORPOISE FISHERY.**

Indian porpoise hunters of Puseamaquoddy Bay; canoe, rifle, and lance for capture of porpoise. (Sect. v, vol. ii, p. 306.)  
From a photograph by T. W. Smillie.

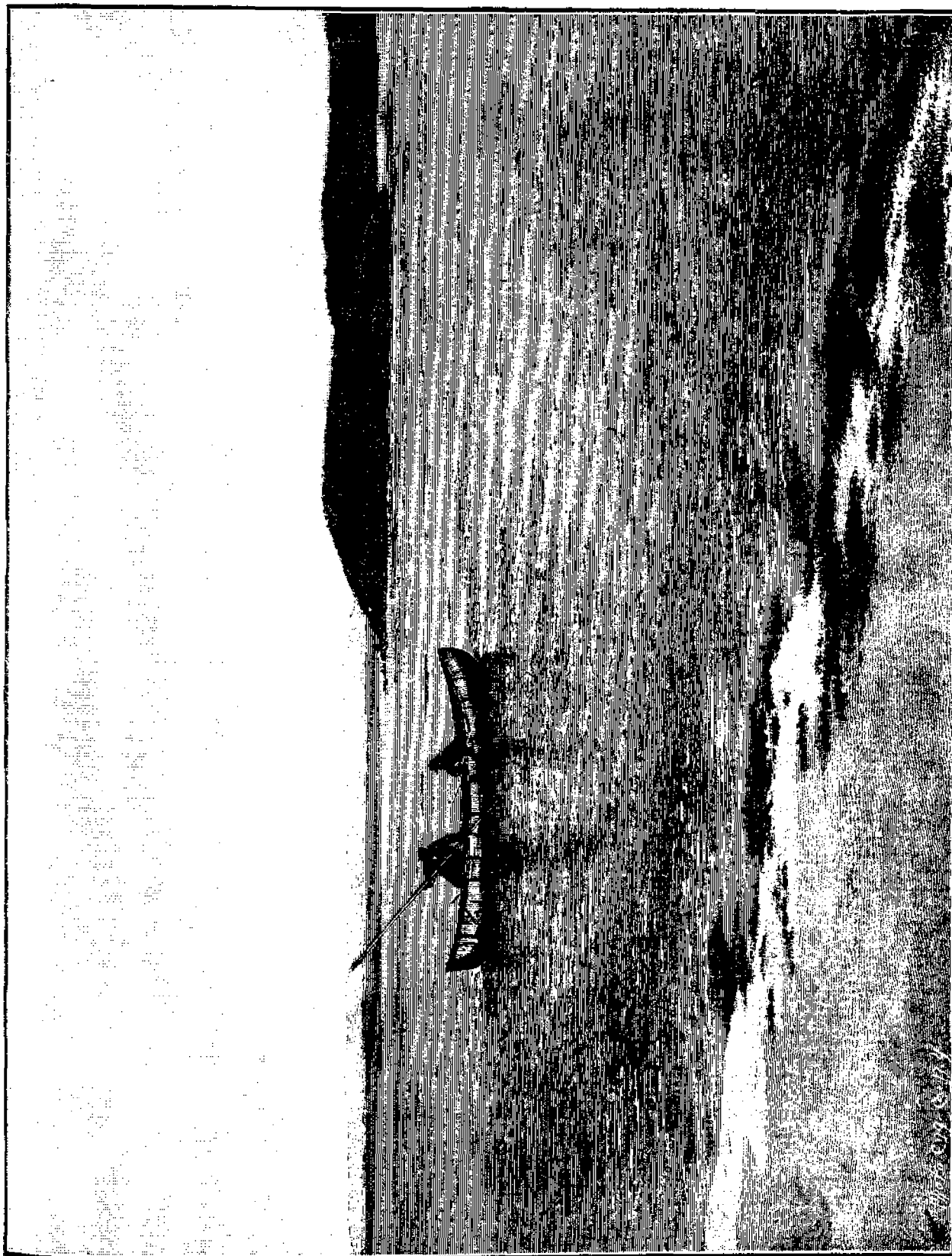

**THE PORPOISE FISHERY.**

Passamaquoddy Bay Indians lancing and securing a porpoise. (Seal, v. vol. ii, p. 302.)

From a photograph by T. W. Stillie



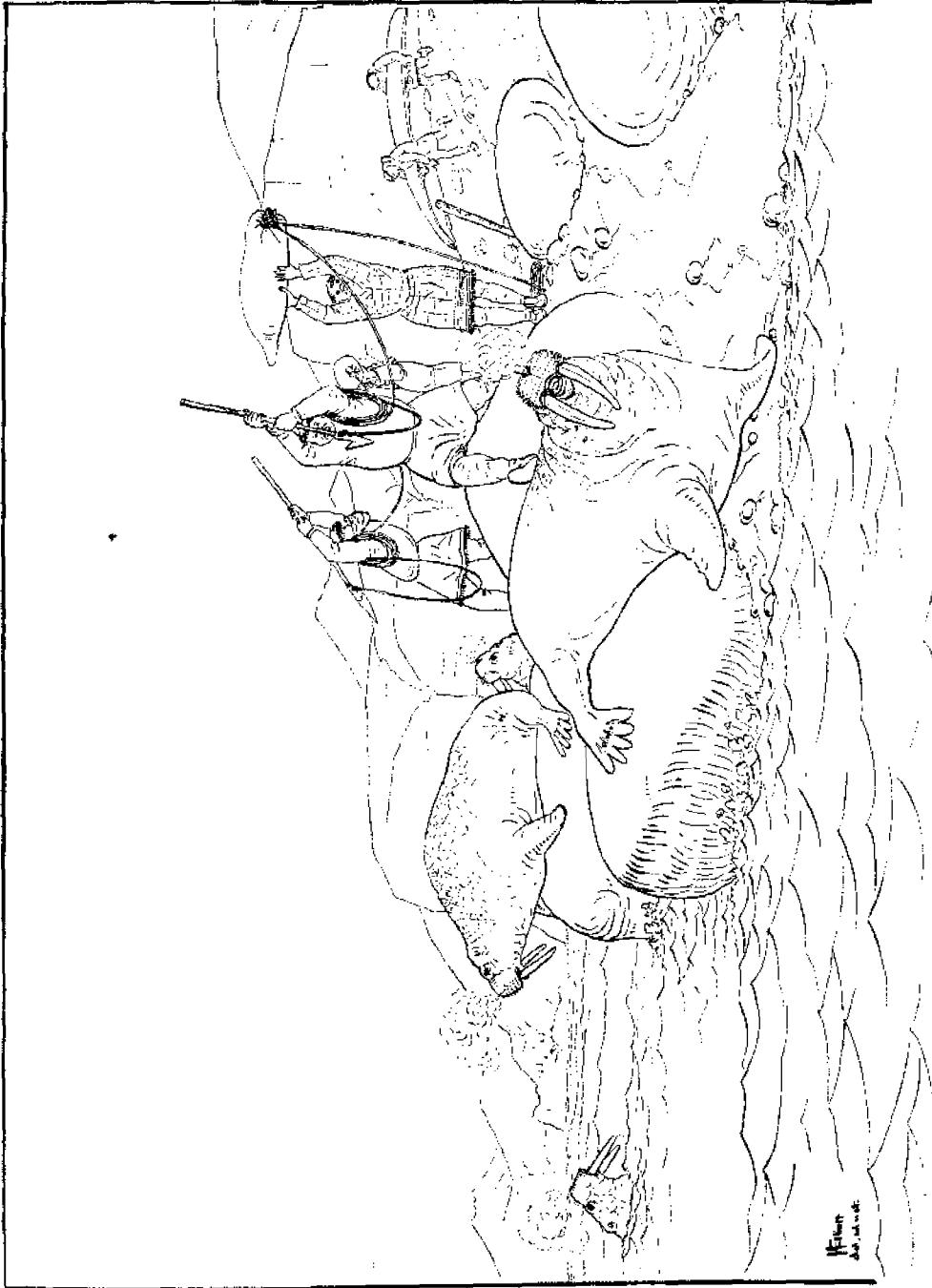

**THE PACIFIC WALRUS FISHERY.**

Inuits of St. Lawrence Island, Alaska, surprising and harpooning a herd of walrus. (Sect. v, vol. II, p. 313.)

Drawing by H. W. Elliott.

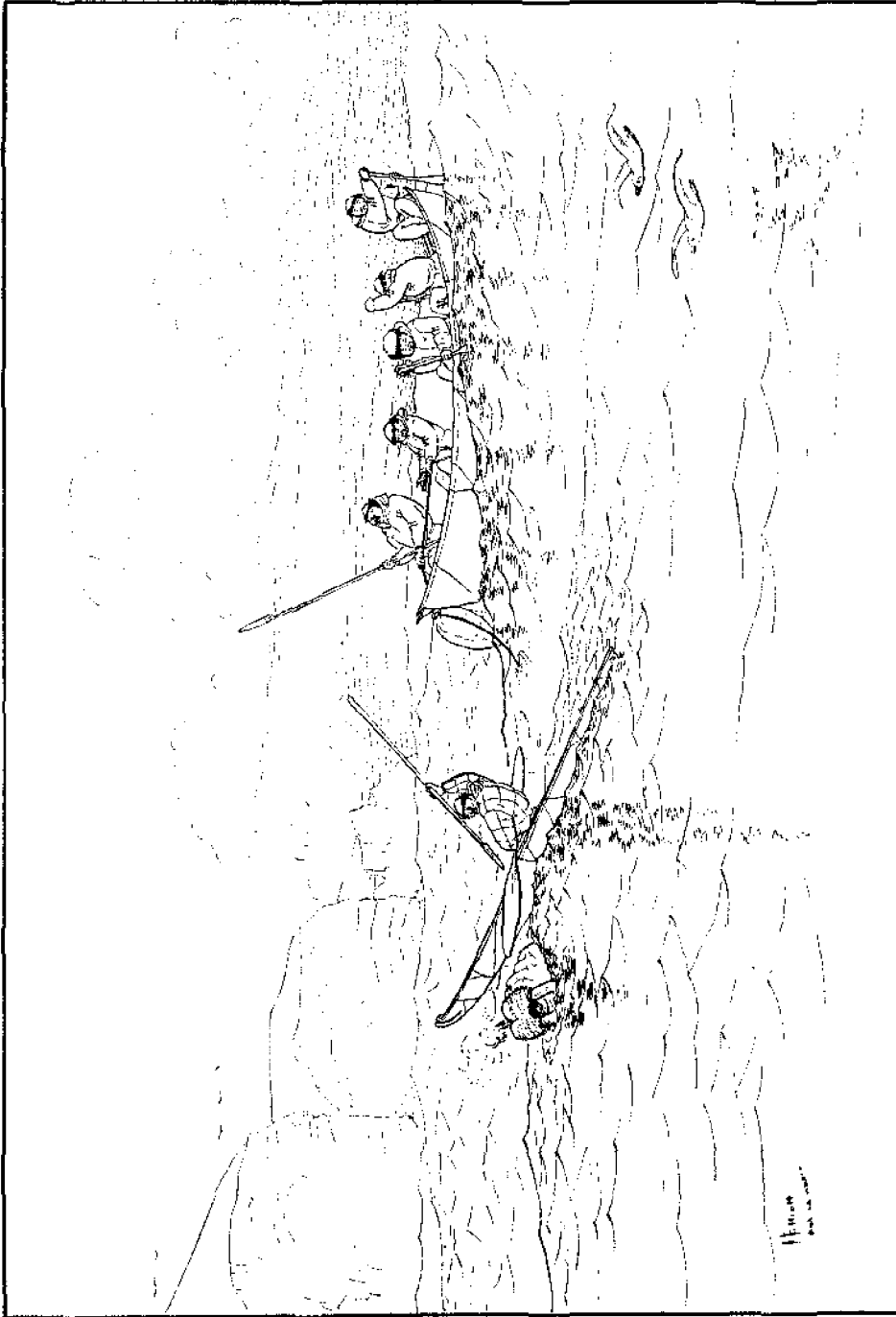

**THE PACIFIC WALRUS FISHERY.**

The walrus "coup": Eskimo lancing the exhausted walrus, St. Lawrence Island; Mahlemoot dressers, baidar, etc., of Alaska.  
(Sect. V, vol. II, p. 313.)

Drawing by H. W. Elliott.

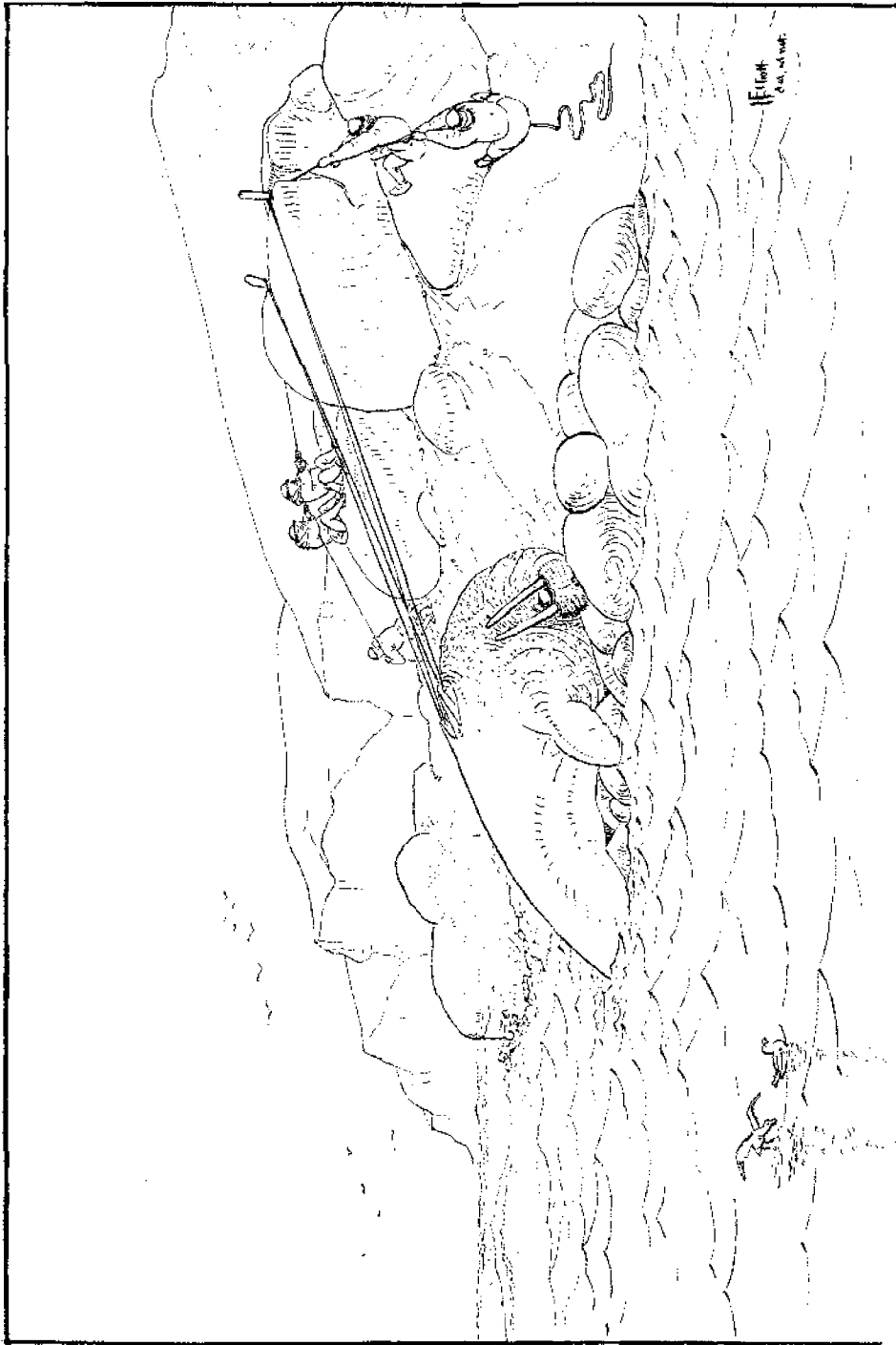

**THE PACIFIC WALRUS FISHERY.**

Hunters of St. Lawrence Island, Alaska, hoisting a walrus carcass. (Seal. V. vol. ii, p. 311.)

Drawing by H. W. Elliott.

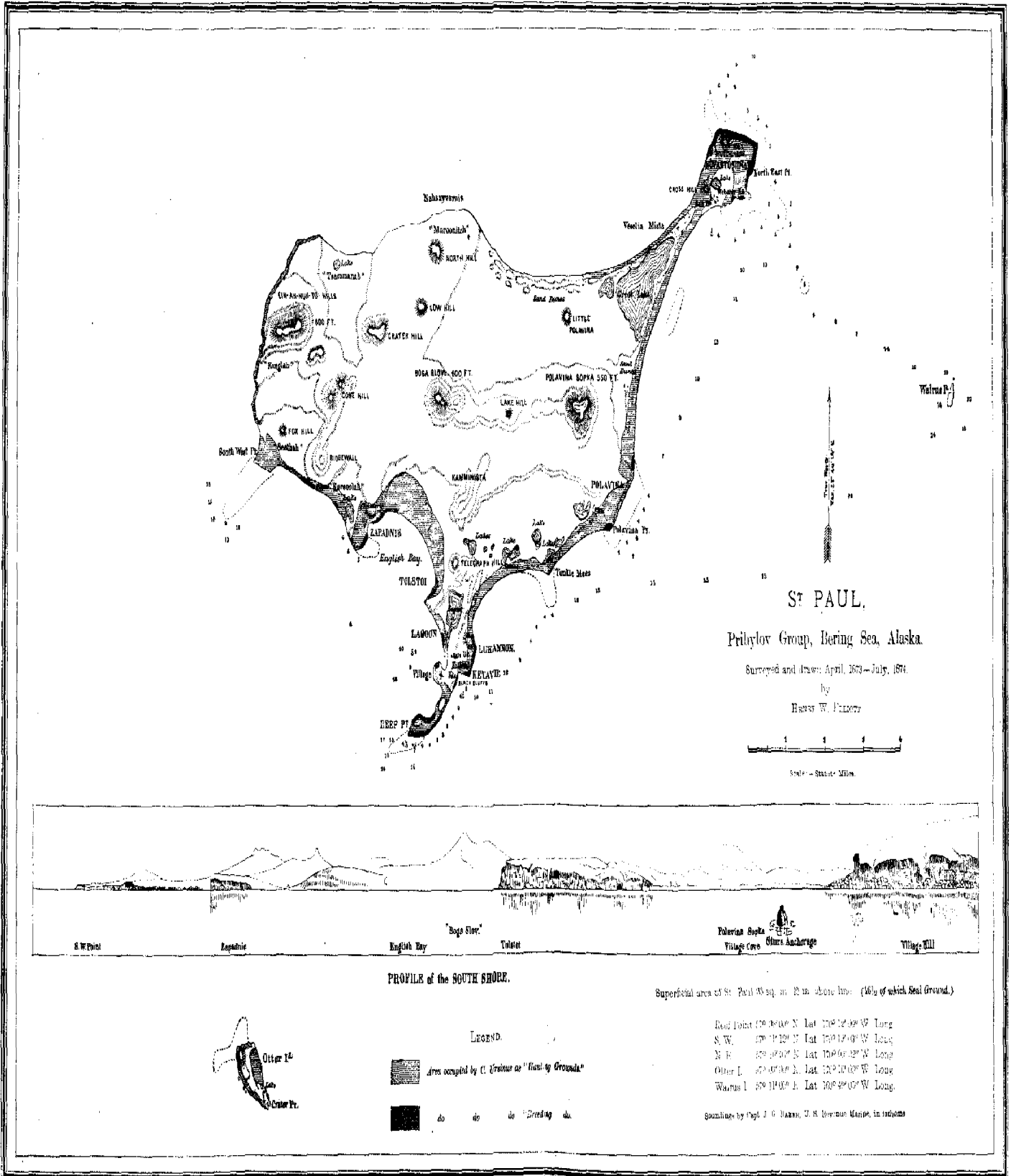

**THE FUR-SEAL INDUSTRY OF THE PRIBILOF ISLANDS, ALASKA.**

(Sect. v, vol. ii, p. 322.)

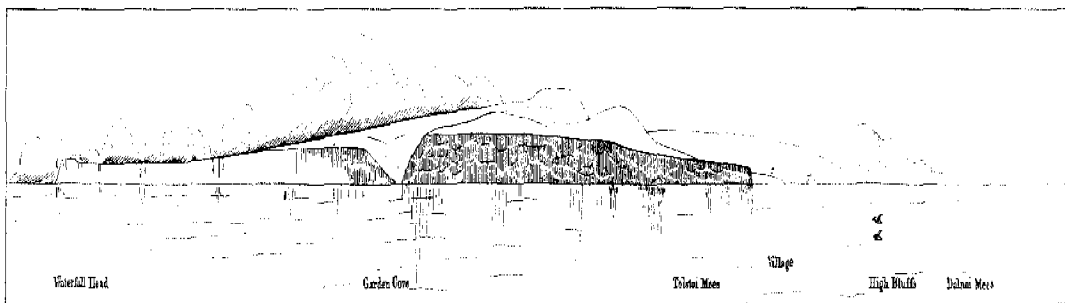

PROFILE of ST GEORGE "Tolstoi Mts" bearing W.S.W. 7 m.

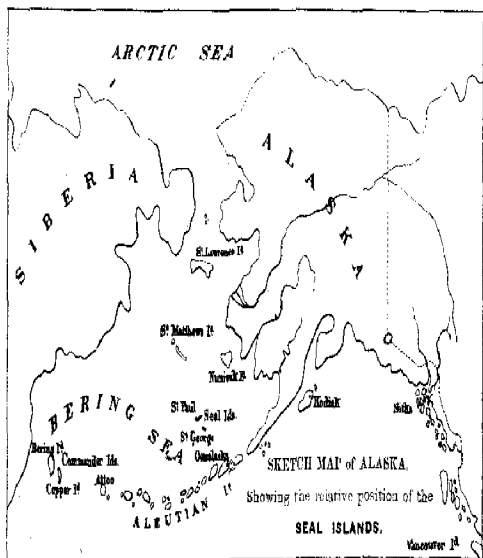
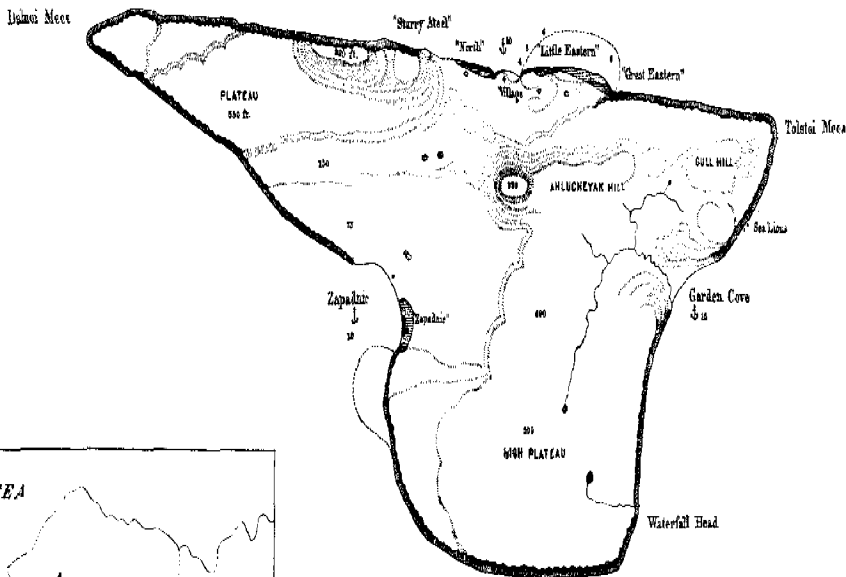



ST GEORGE,

Pribylov Group, Bering Sea, Alaska.

Surveyed and drawn April, 1871—July, 1871.

by  
HENRY W. ELLISON.

LEGEND.

-  Area occupied by *V. Ursinus* or "Herring Grouse."
-  do do do "Breeding do."

Superficial area 27 sq. m. 20 m. coast  
(Only 2 1/2 of which occupied by seals.)



Tolstoi Mts. 66° 37' 00" N. Lat. 158° 37' 00" W. Long.  
Dalni Mts. 66° 38' 00" N. Lat. 158° 12' 00" W. Long.  
Village. 66° 39' 00" N. Lat. 158° 12' 00" W. Long.

Water to port and back all around island, 20 to 25 fathoms.

THE FUR-SEAL INDUSTRY OF THE PRIBYLOV ISLANDS, ALASKA.

(Sect. v, vol. ii, p. 322.)

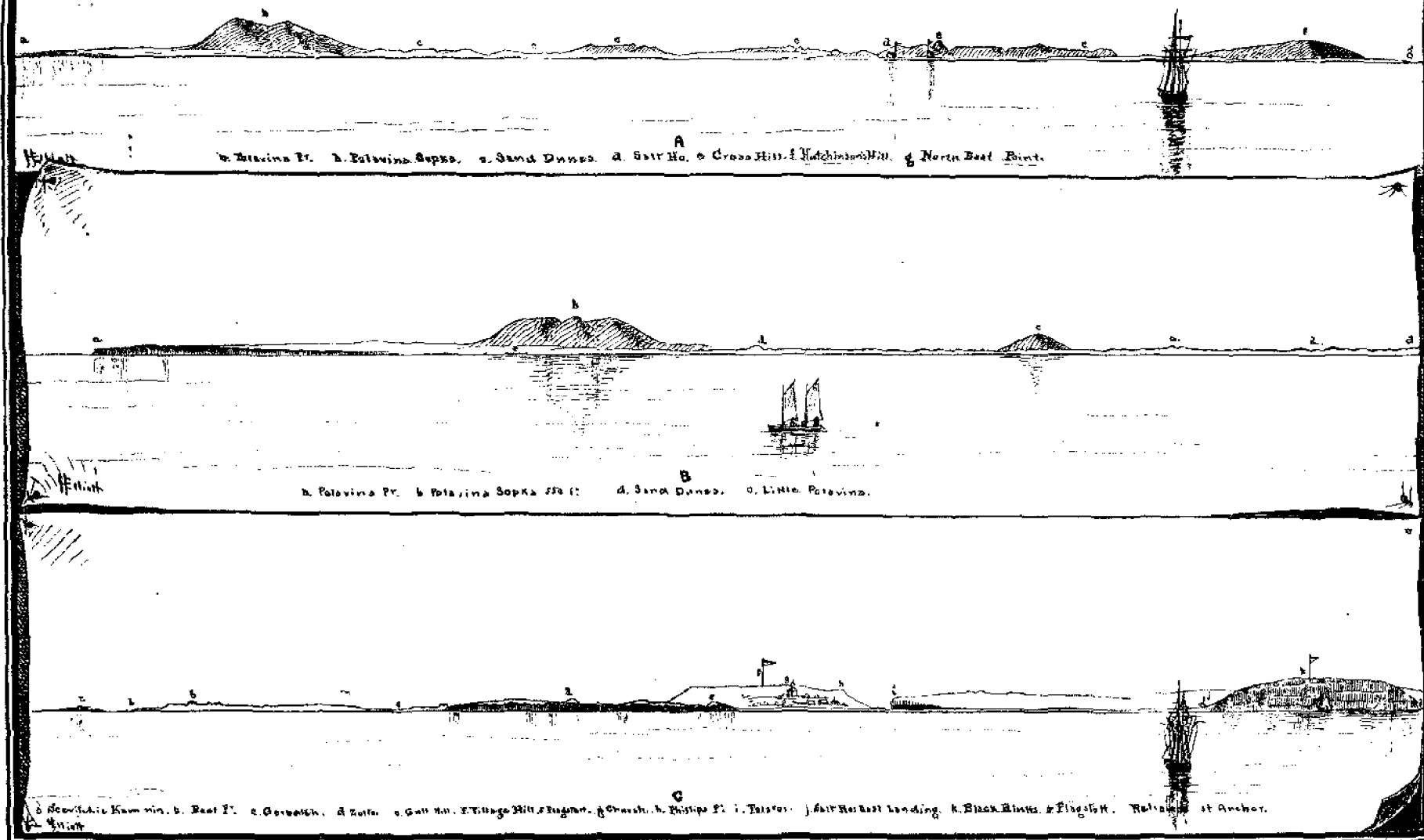

**THE FUR-SEAL INDUSTRY OF THE PRIBYLOV ISLANDS, ALASKA.**

Profiles of the east coast of St. Paul's Island. (Sect. v, vol. ii, pp. 325-329.)

- A. Northeast shore of St. Paul's Island, from a point at sea about eight miles distant to eastward, magnetic.
- B. Polovina Sopka and Point, from a seaward view three miles distant; the mountain bearing west, magnetic.
- C. Village and East Landing, from the usual anchorage there; one mile distant.

Drawing by H. W. Elliott.

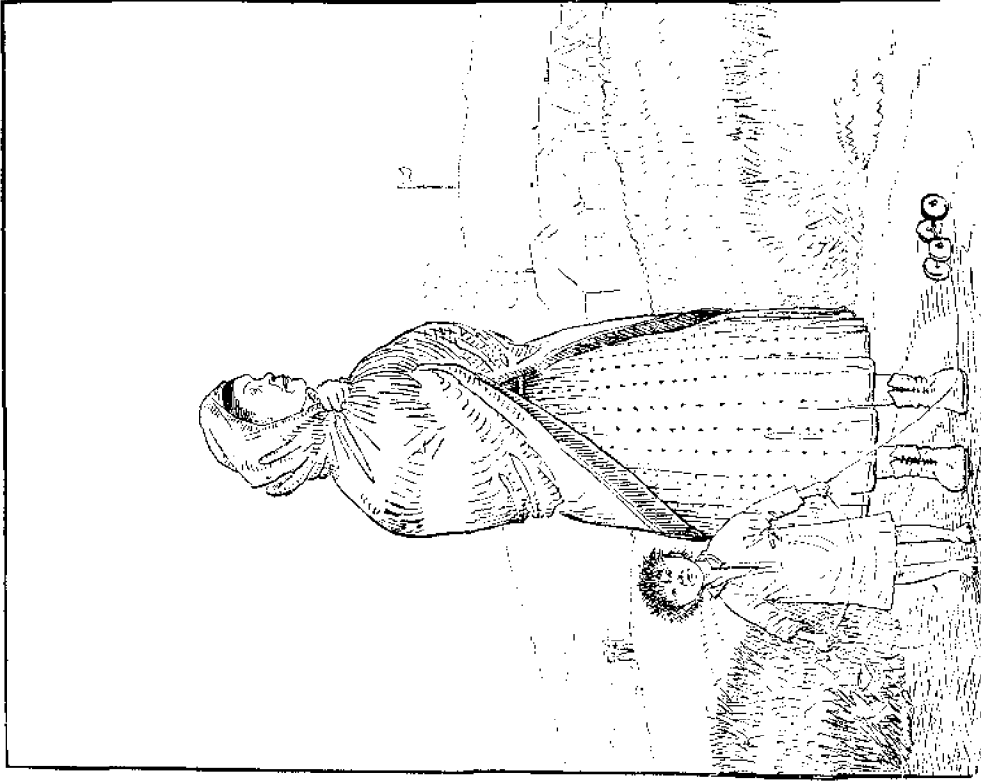

His Wife and Child

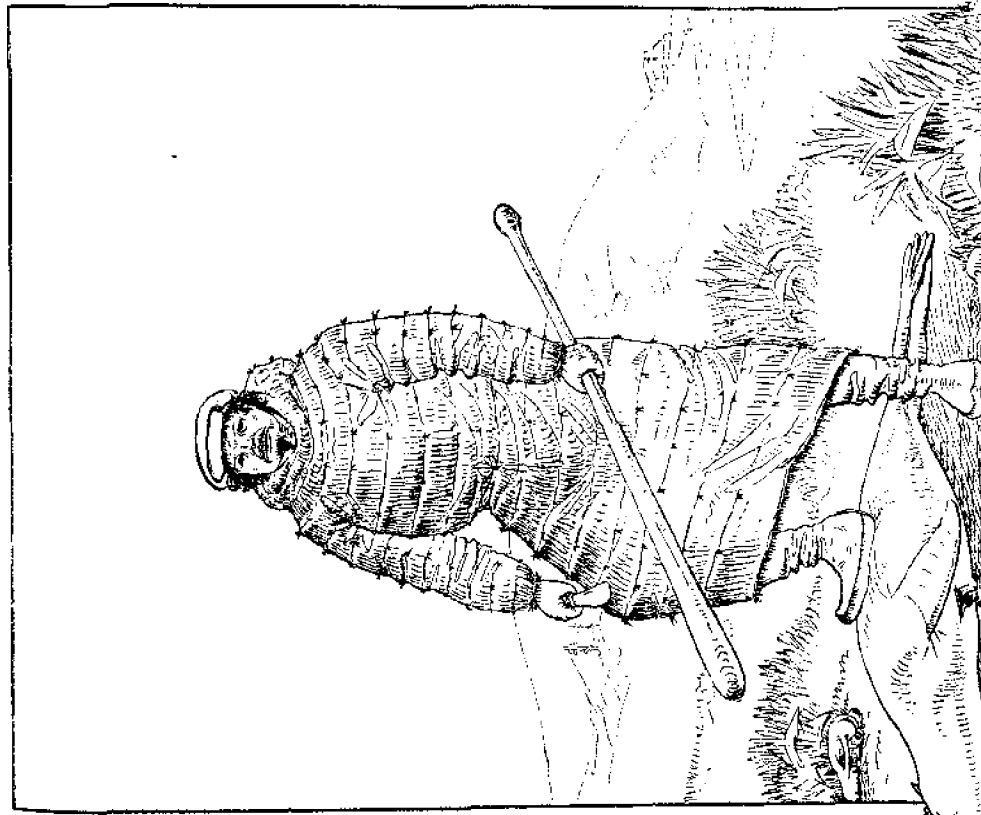

Costumes of the People  
Fribylov Group.

Native Seales

THE FUR-SEAL INDUSTRY OF THE FRIBYLOV ISLANDS, ALASKA.

Ordinary attire of men on the killing ground and of women and young children in the village. (Seal. V, vol. II, p. 320.)

Drawing by H. W. Elliott.

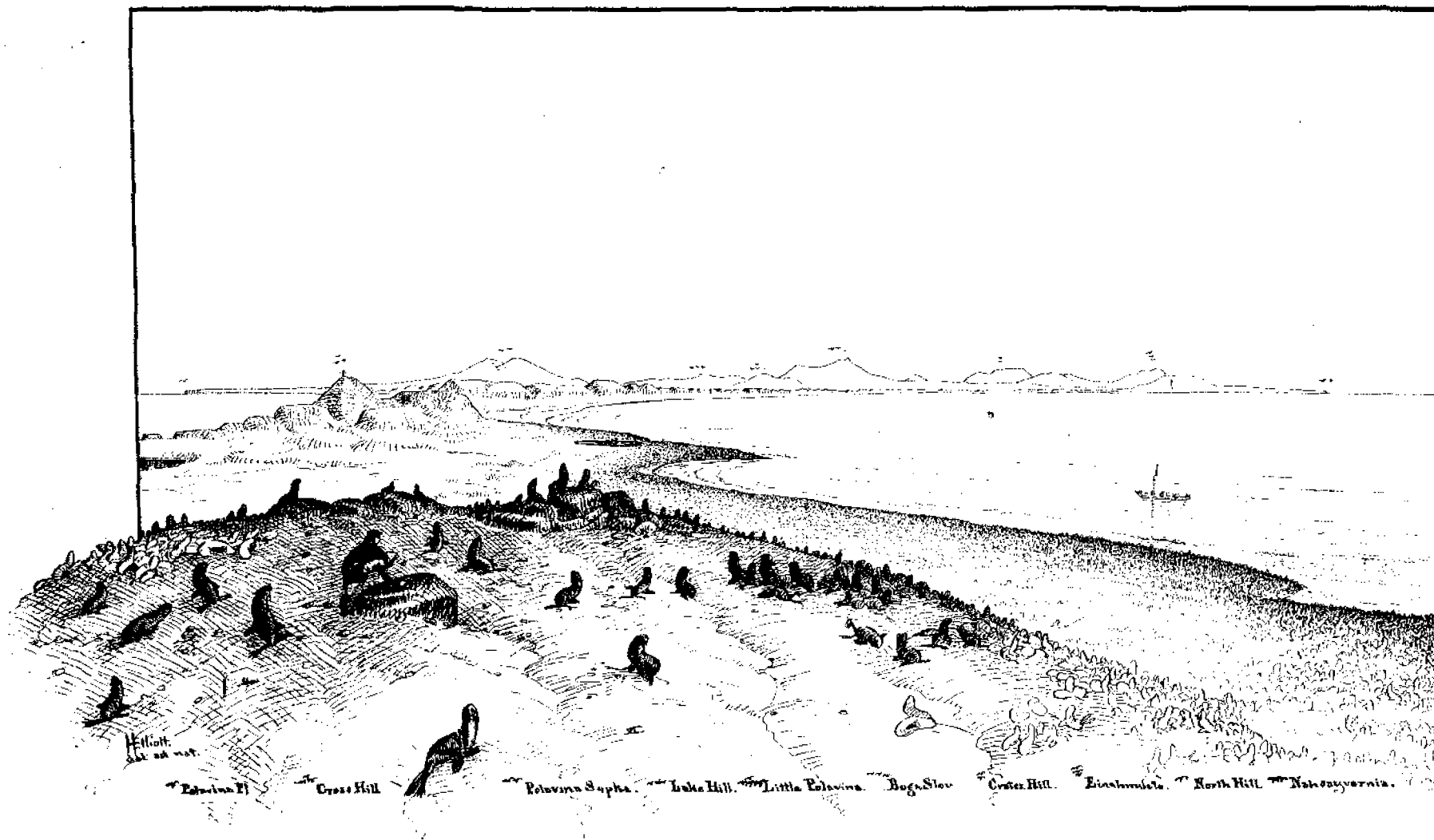

**THE FUR-SEAL INDUSTRY OF THE PRIBYLOV ISLANDS, ALASKA.**

The north shore of Paul's Island, view looking W.S.W. from the summit of Hutcheson's Hill. (Sect. v, vol. ii, p. 336.)

Drawing by H. W. Elliott.



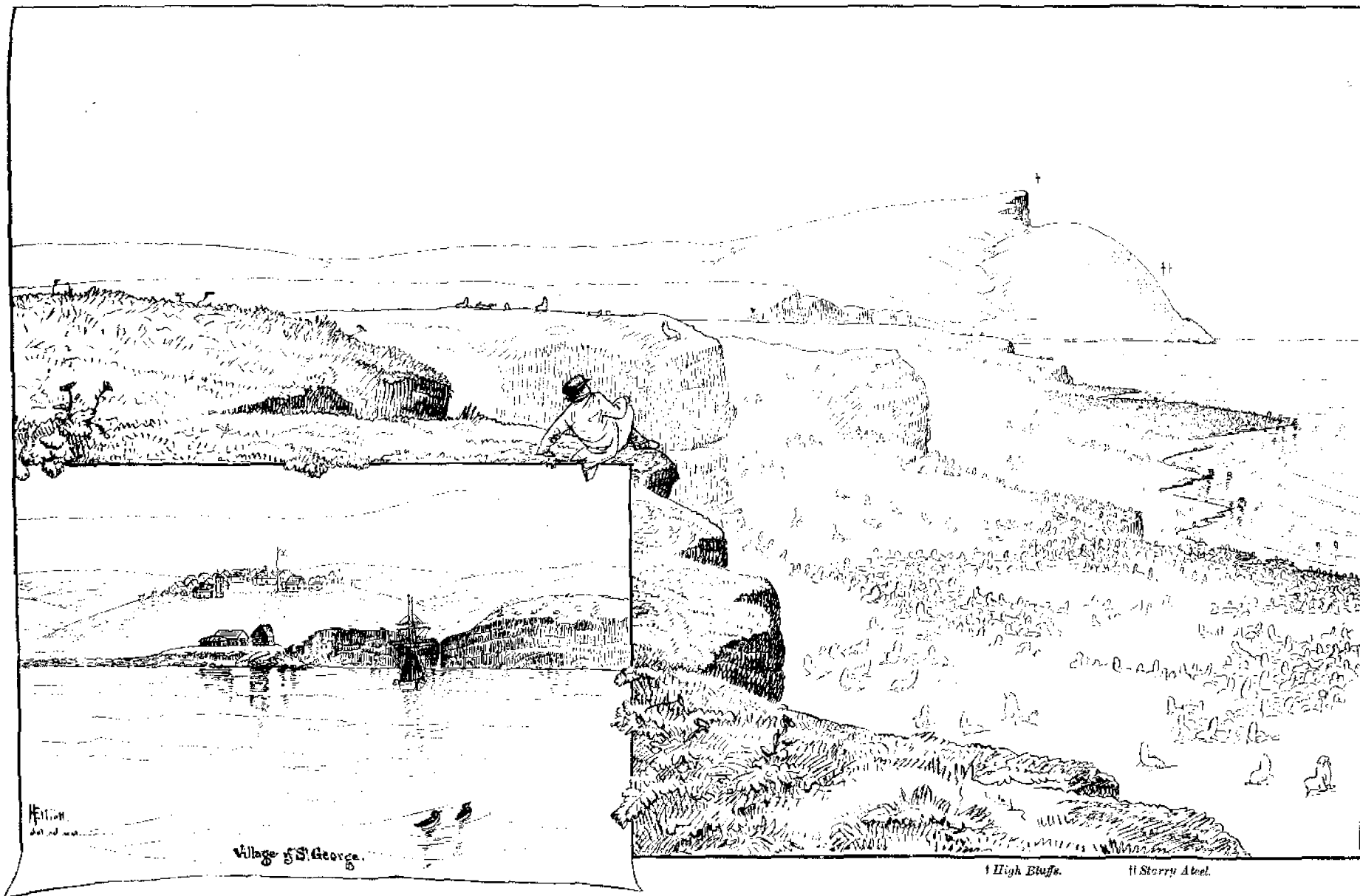

THE FUR-SEAL INDUSTRY OF THE PRIBYLOV ISLANDS, ALASKA.

Viewing the North Rookery, looking west to Starry Ateel, St. George Island. (Sect. v, vol. ii, p. 348.)

Drawing by R. W. Elliott.

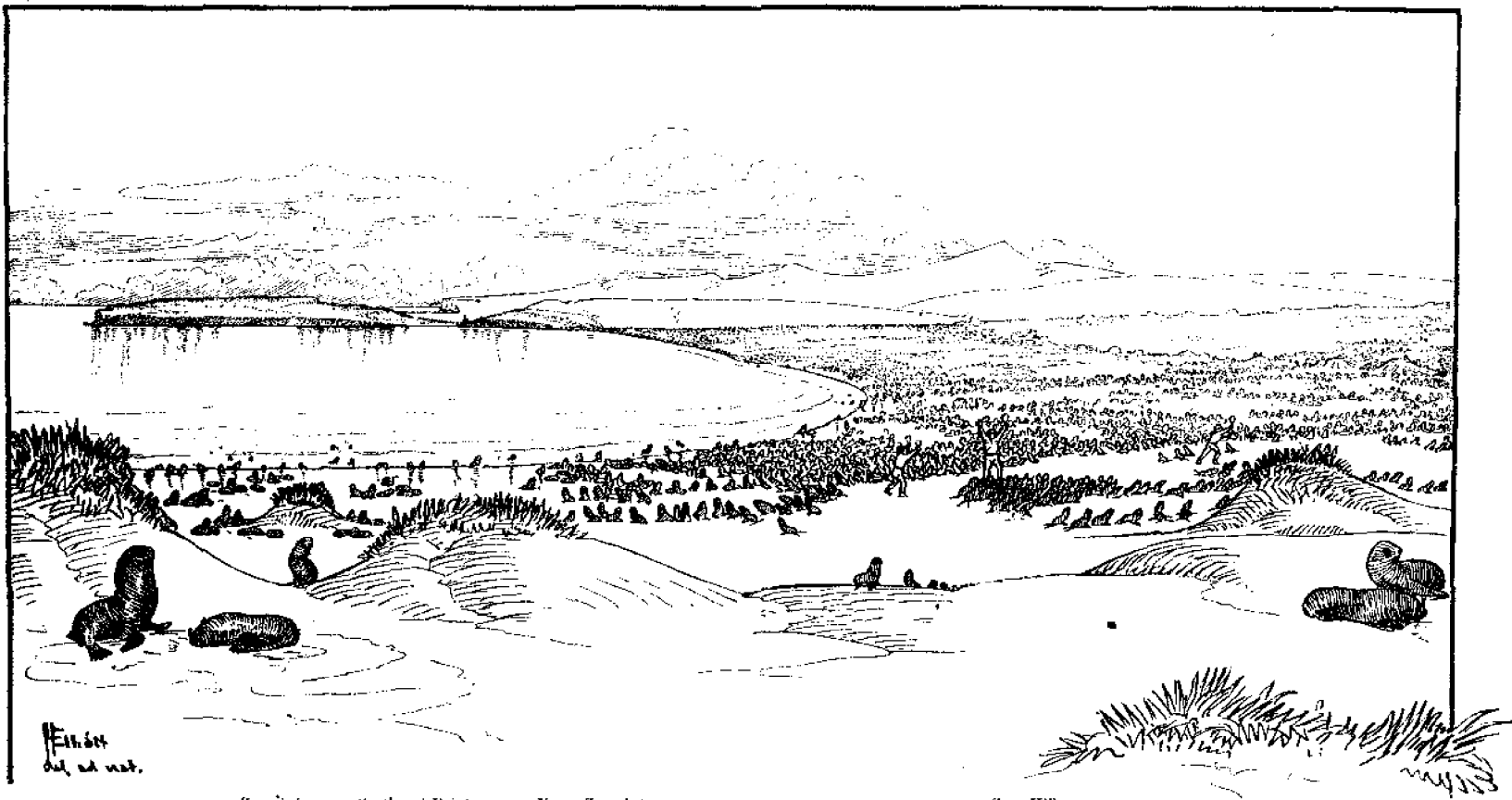

Zapadni.

Southwest Point.

Upper Zapadni.

Cone Hill.

**THE FUR-SEAL INDUSTRY OF THE PRIBYLOV ISLANDS, ALASKA.**

Natives selecting a drive; view over hauling-grounds of "holluschickie" at English Bay, looking west from Tolstoi sand dunes. (Sect. v, vol. ii, p. 363.)

Drawing by D. W. Elliott.

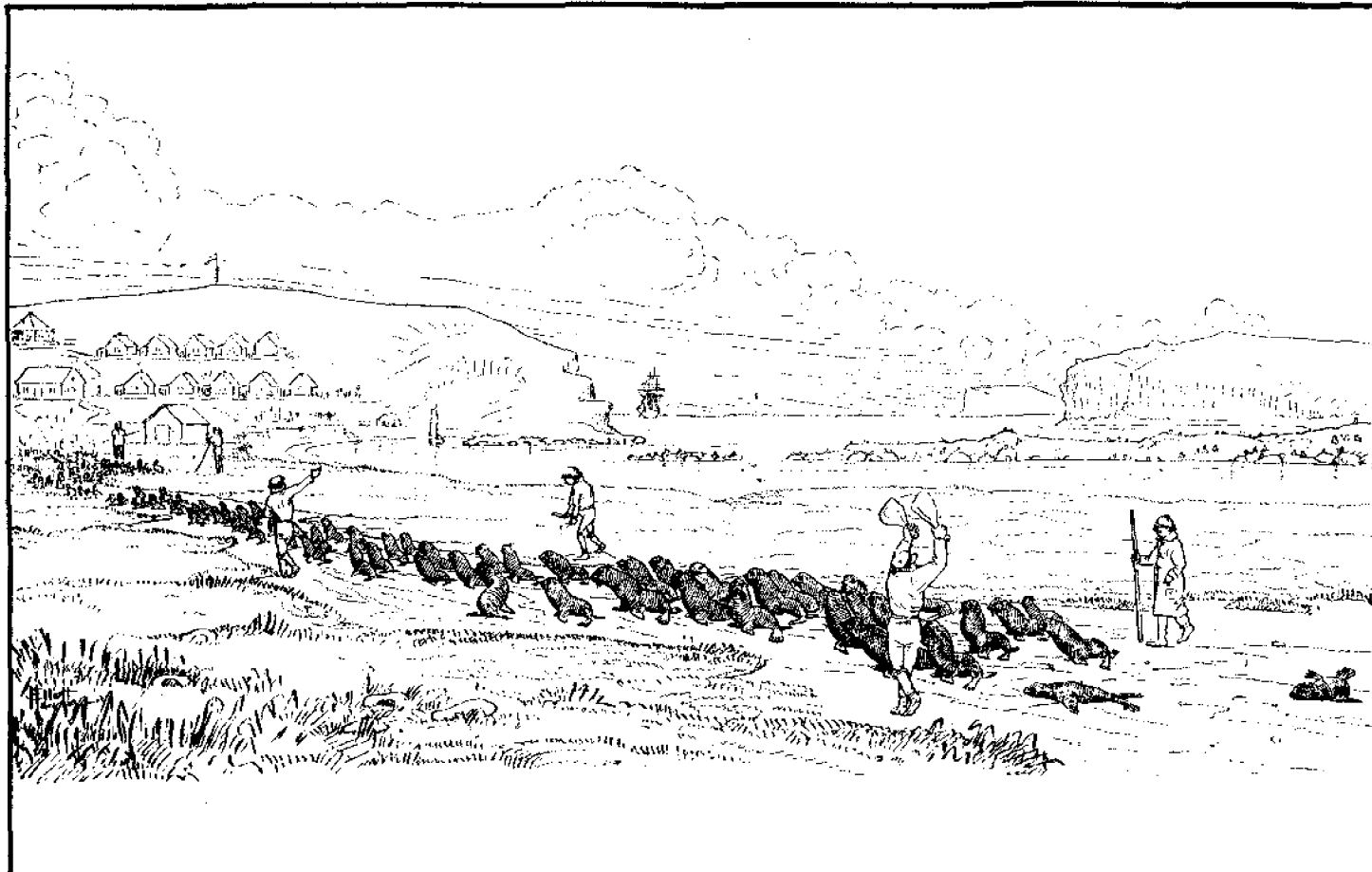

**THE FUR-SEAL INDUSTRY OF THE PRIBYLOV ISLANDS, ALASKA.**

Natives driving the "holluschickie"; the drive passing over the lagoon flats to the killing-ground, under the village hill, St. Paul's Island.  
(Sect. v, vol. ii, p. 363.)

Drawing by H. W. Elliott.



*The drive in waiting.*

*Sealers knocking down a "pod."*

*Natives skinning.*

**THE FUR-SEAL INDUSTRY OF THE PRIBYLOV ISLANDS, ALASKA.**

The killing-gang at work; method of slaughtering fur-seals on the grounds near the village, St. Paul's Island. (Sect. v, vol. ii, p. 365.)

Drawing by H. W. Elliott.

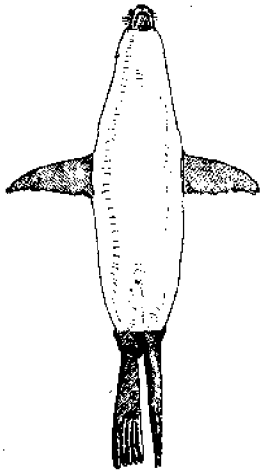

Fig. 2.

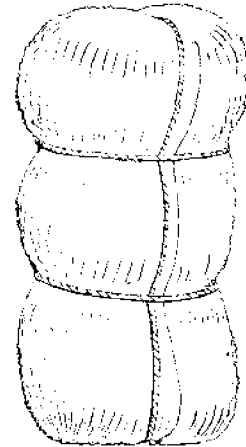
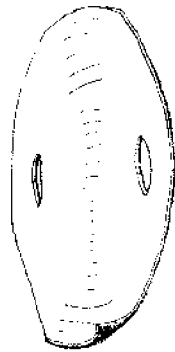

Fig. 3.

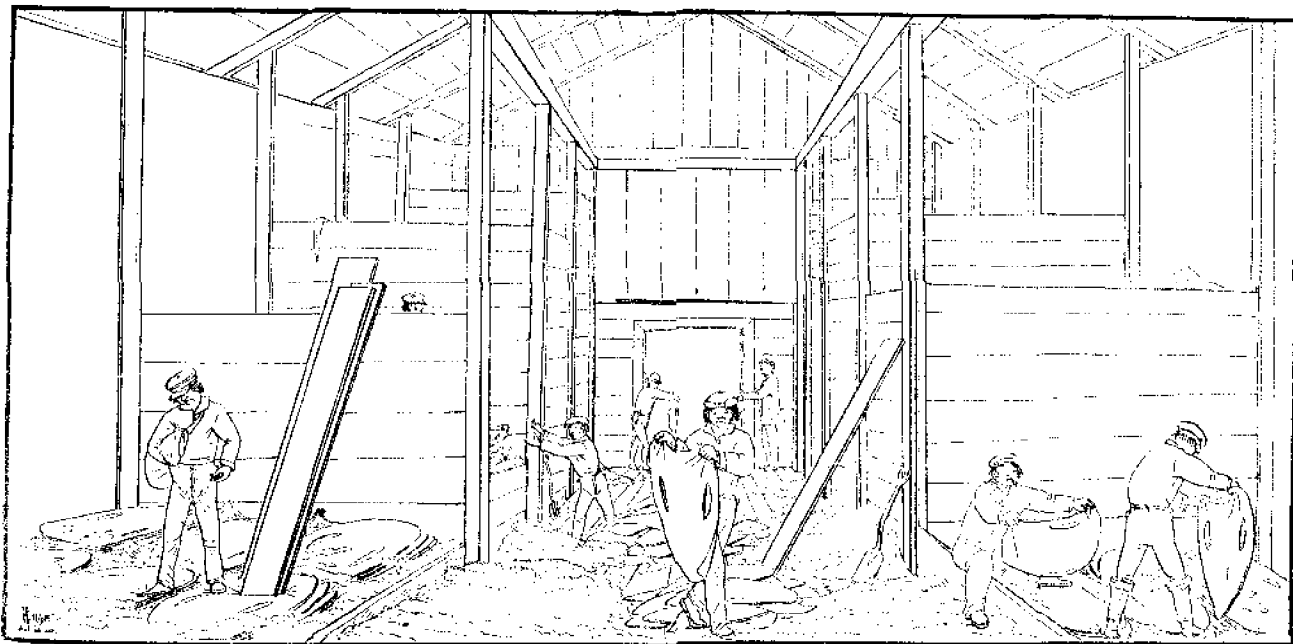

Fig. 1.

### THE FUR-SEAL INDUSTRY OF THE PRIBYLOV ISLANDS, ALASKA.

Preparing the skins for shipment. (Sect. v, vol. ii, p. 369.)

FIG. 1. Interior of salt-house, St. Paul's Island; natives salting and assorting the pelts.

FIG. 2. The flensed carcass of a fur-seal and the skin as taken therefrom.

FIG. 3. A bundle of skins ready for shipment.

Drawings by H. W. Elliott.

# SKETCH OF HERD'S ISLAND. ANTARCTIC OCEAN.

Lat. 55° 10' S. Long. 73° 30' E.

From the notes of fishermen.

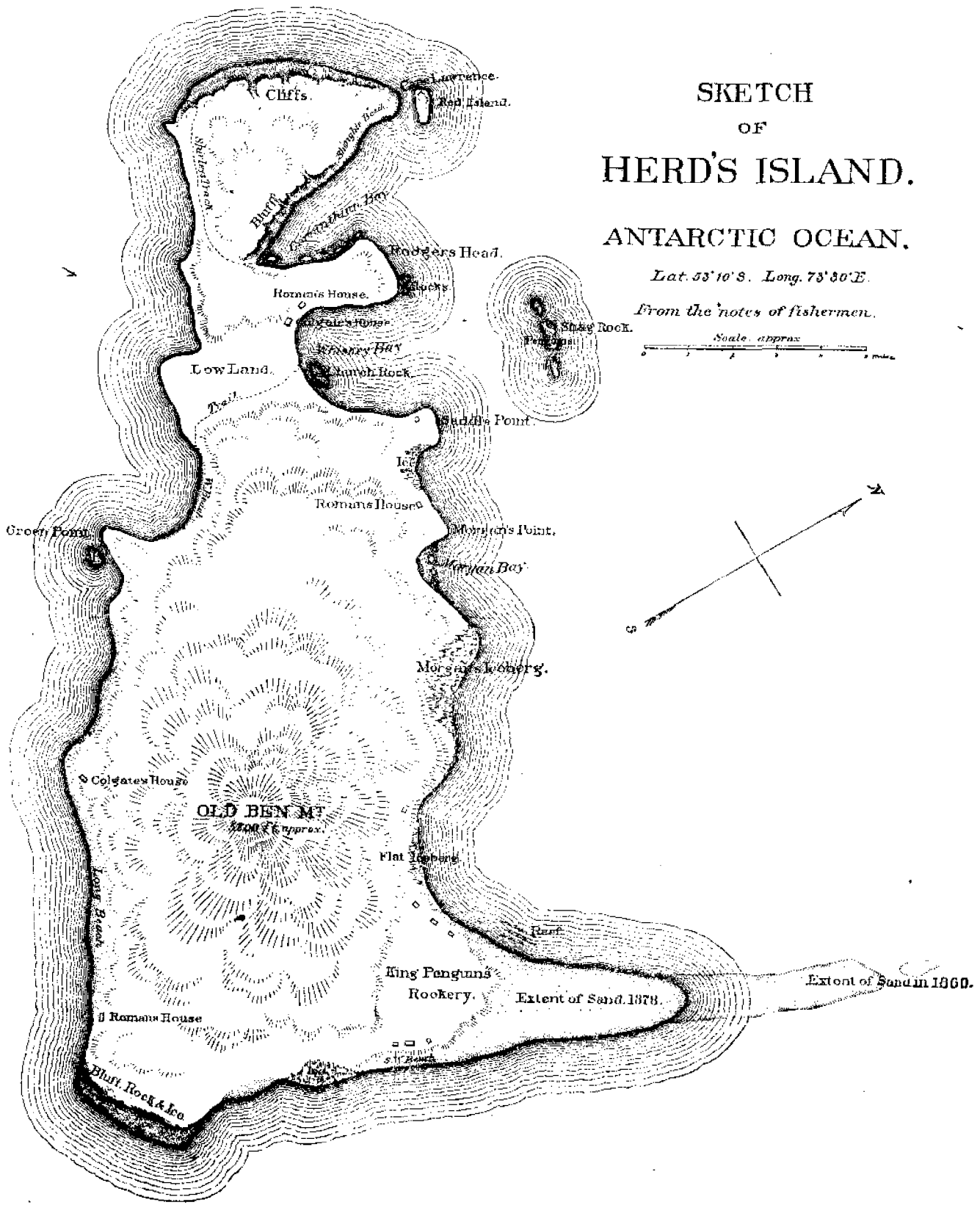
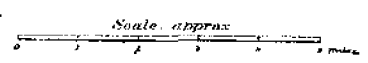

## THE ANTARCTIC SEA-ELEPHANT FISHERY.

(Sect. v, vol. ii, p. 419.)

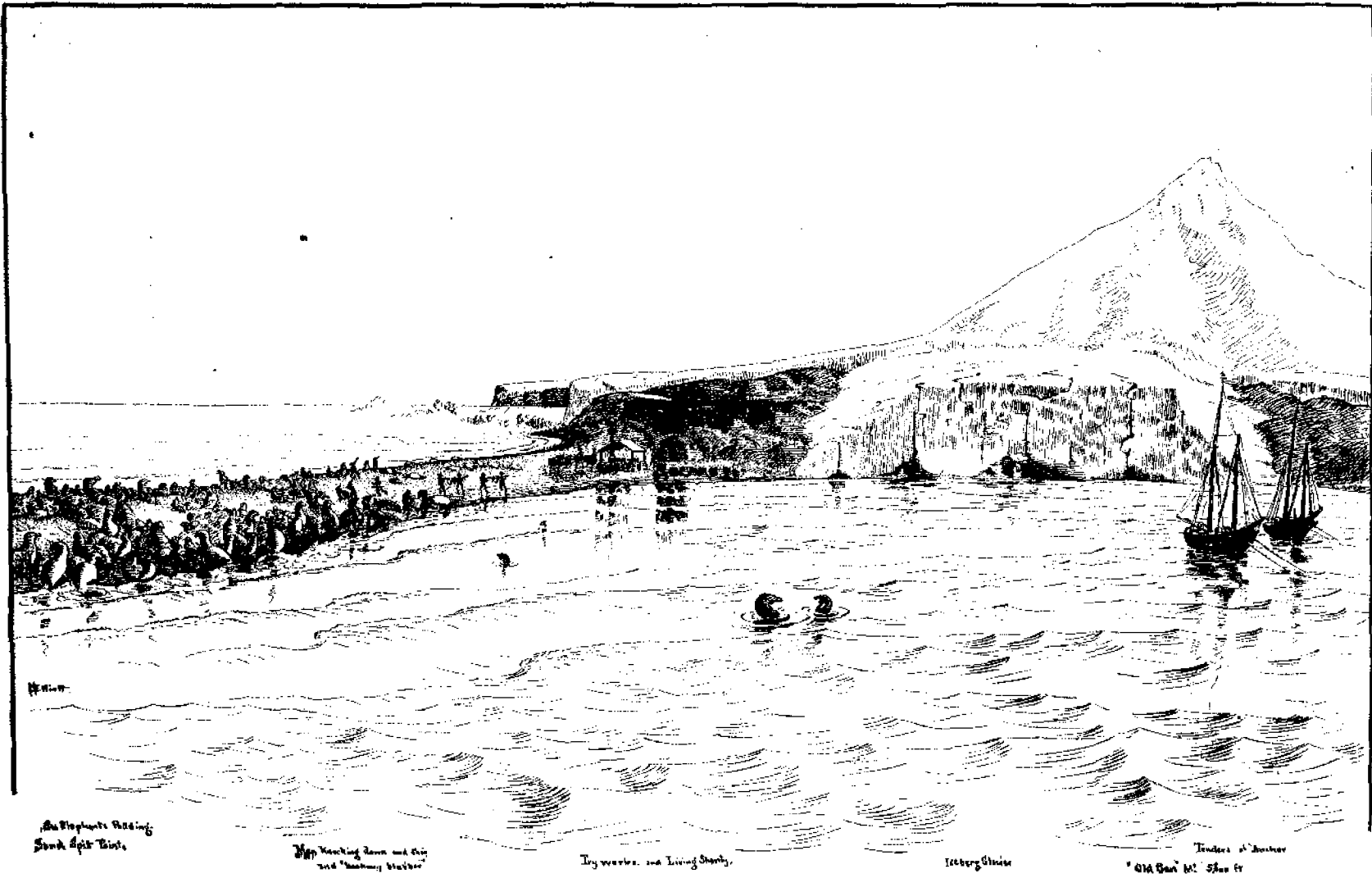

**THE ANTARCTIC SEA-ELEPHANT FISHERY.**

Working sea-elephants at Northeast Point, Herd's Island. (Sect. v, vol. ii, pp. 413, 435.)

Drawing by H. W. Elliott, after Capt. H. C. Chester.

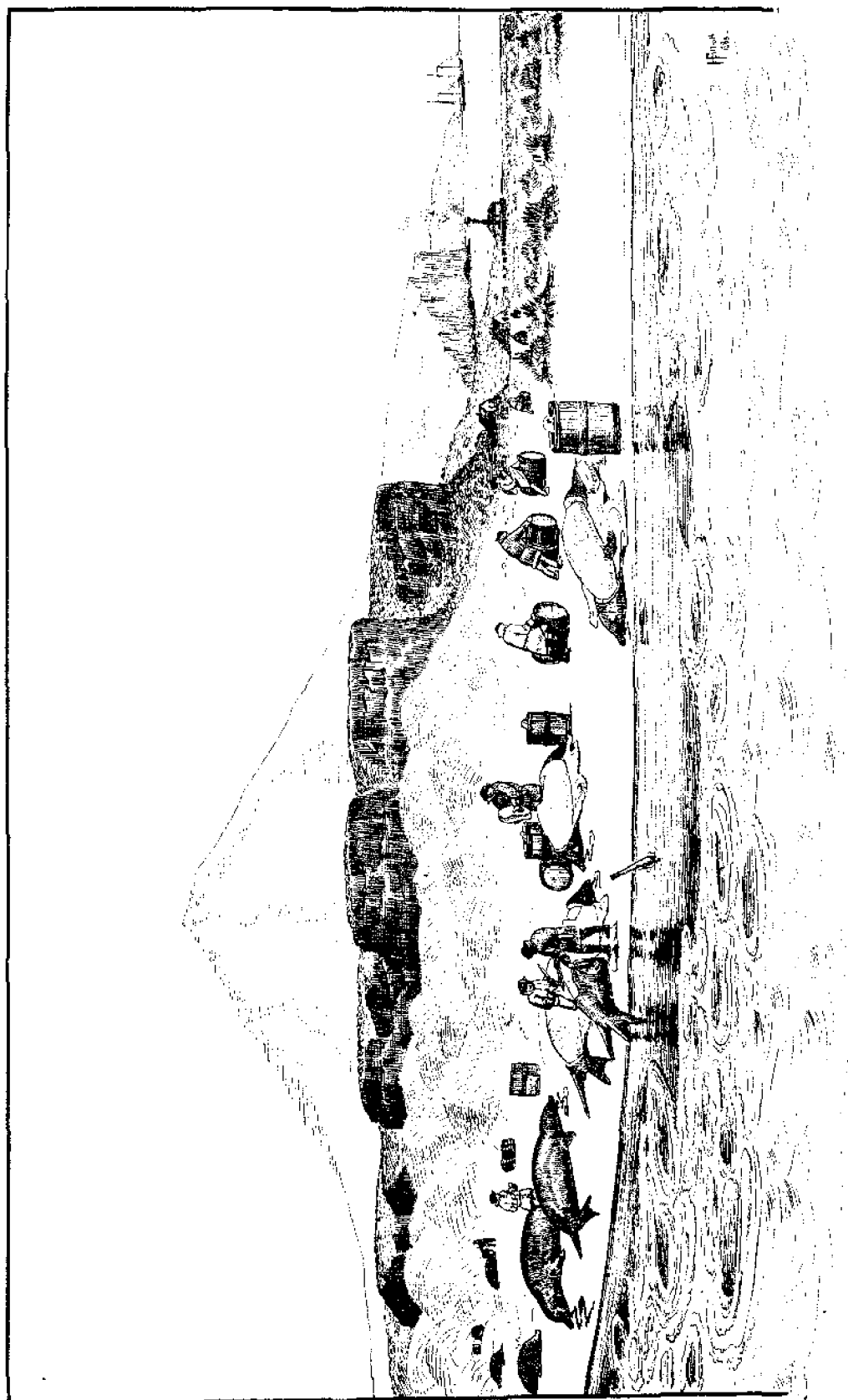

THE ANTARCTIC SEA-ELEPHANT FISHERY.

Stripping blubber and rolling it in barrels to try-works, Southwest Beach, Herd's Island. (Sect. v, vol. ii, pp. 419, 435.)

Drawing by H. W. Ellipt., after Capt. H. C. Chaskey.



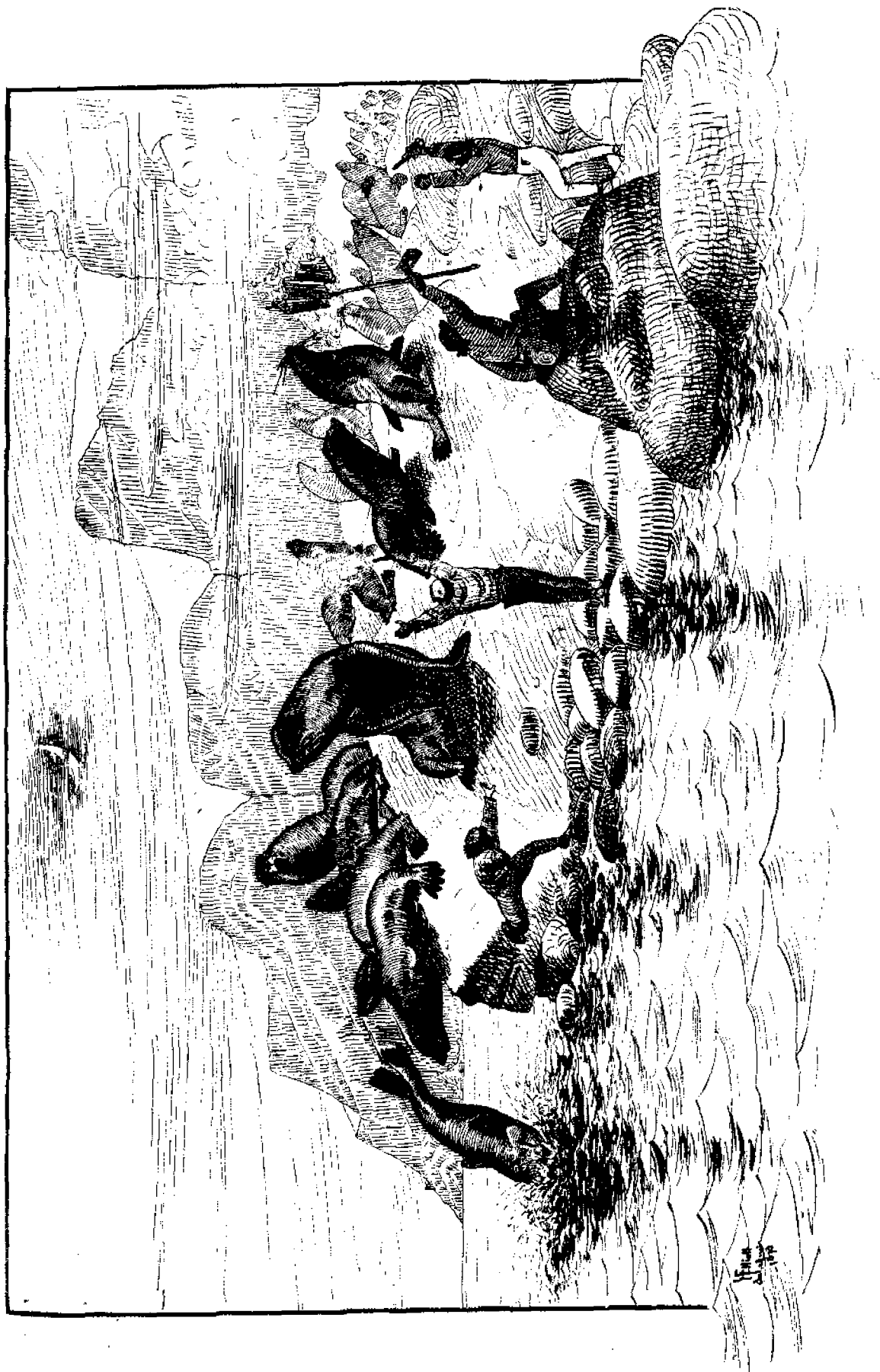

THE SEA-LION HUNT ON PRIBYLOV ISLANDS.

Natives capturing the sea-lion: springing the alarm. (Sect. v, vol. ii, p. 468.)

Drawing by H. W. Elliott.

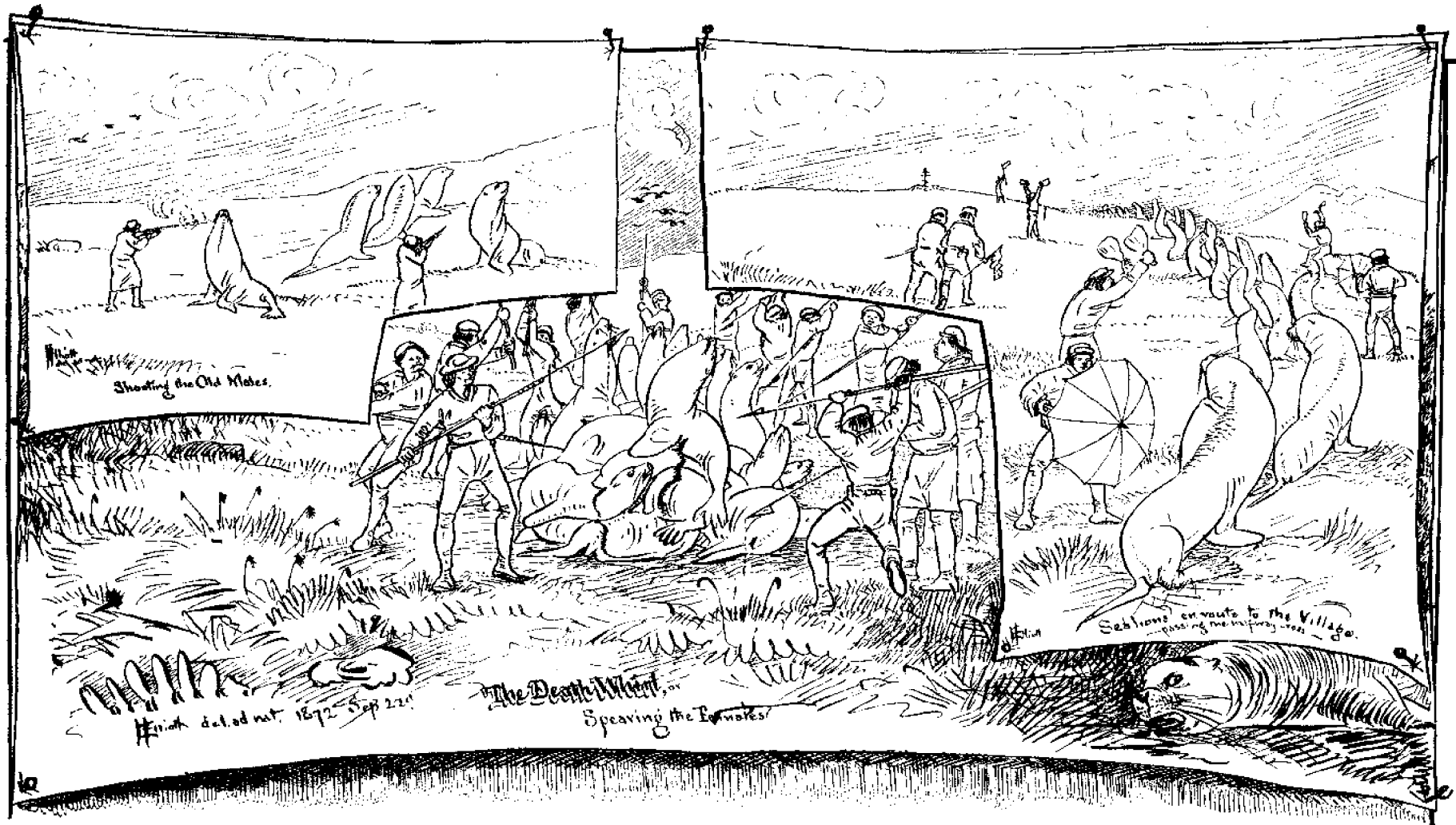

**THE SEA-LION HUNT ON PRIBYLOV ISLANDS.**

Shooting the old males: spearing the surround: the drive. (Sect. v, vol. ii, pp. 468, 469, 471.)

Drawing by H. W. Elliott.

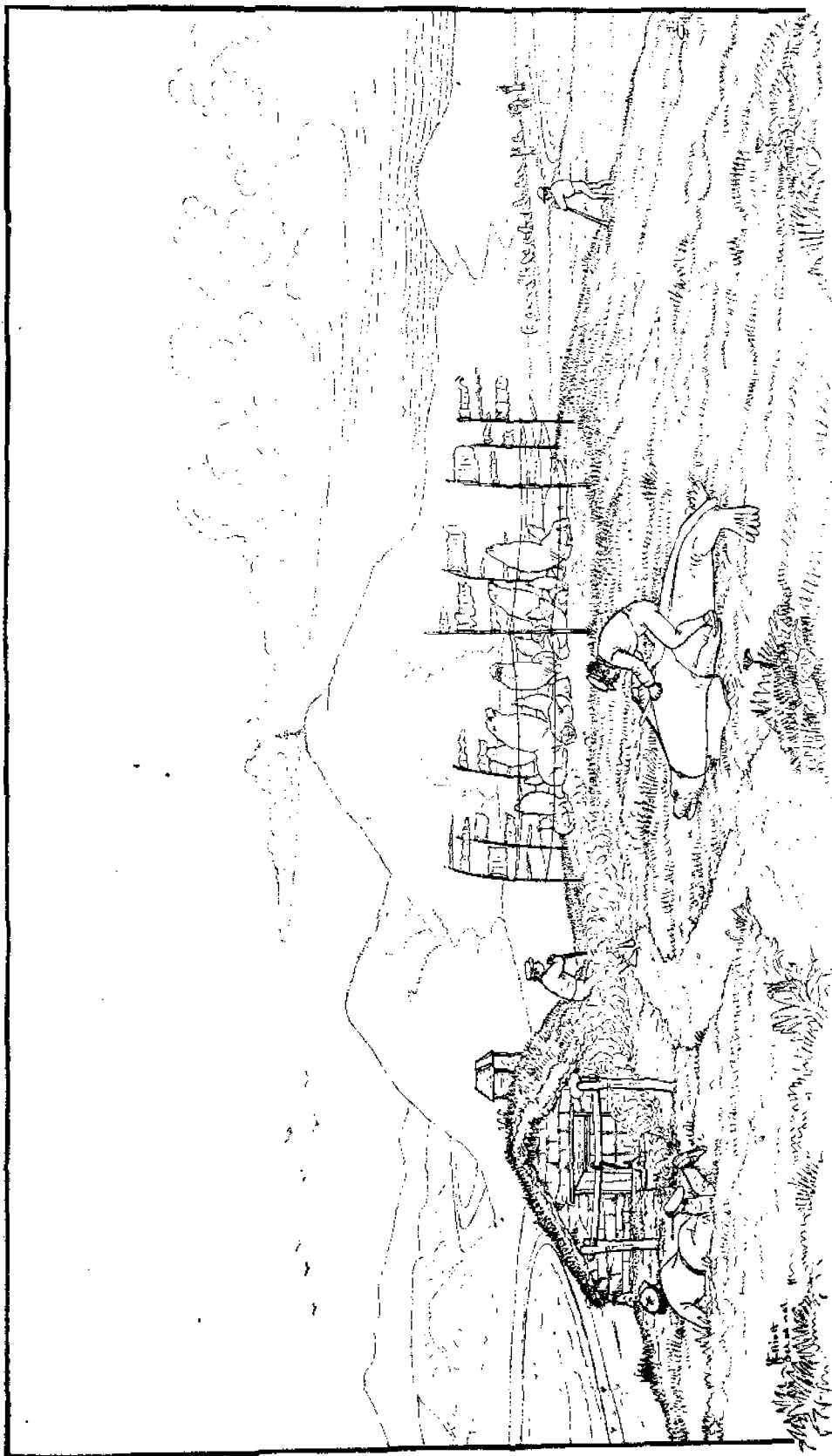

THE SEA-LION HUNT ON PRIBYLOV ISLANDS.

The corral of sea-lions at the Barrabbora, under Cross Hill, Northeast Point, St. Paul's Island. (Sect. v, vol. ii, p. 463.)

Drawing by H. W. Elliott.

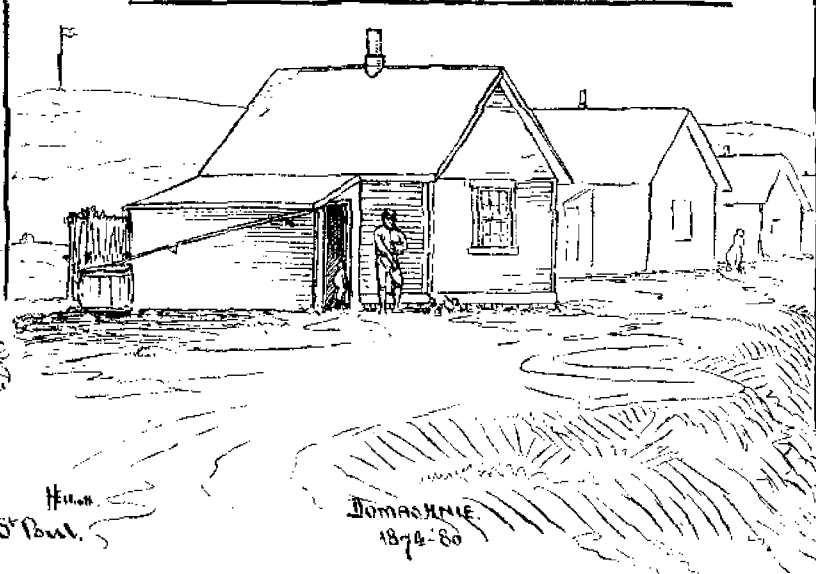
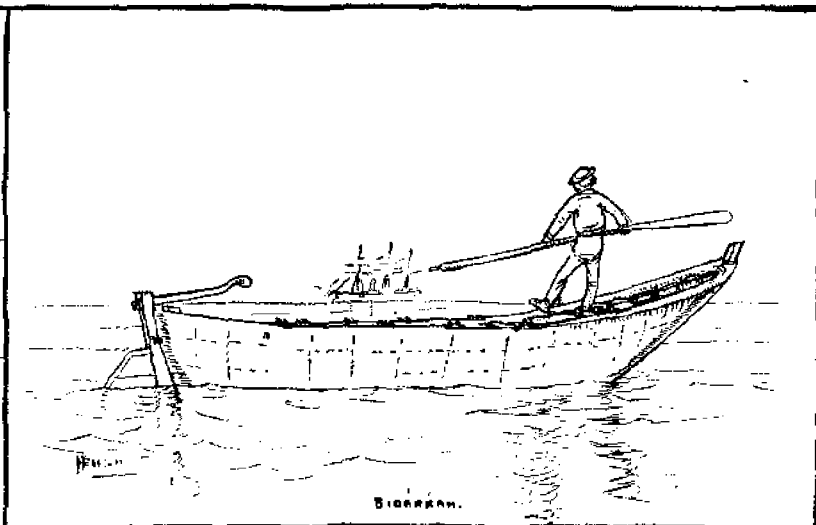
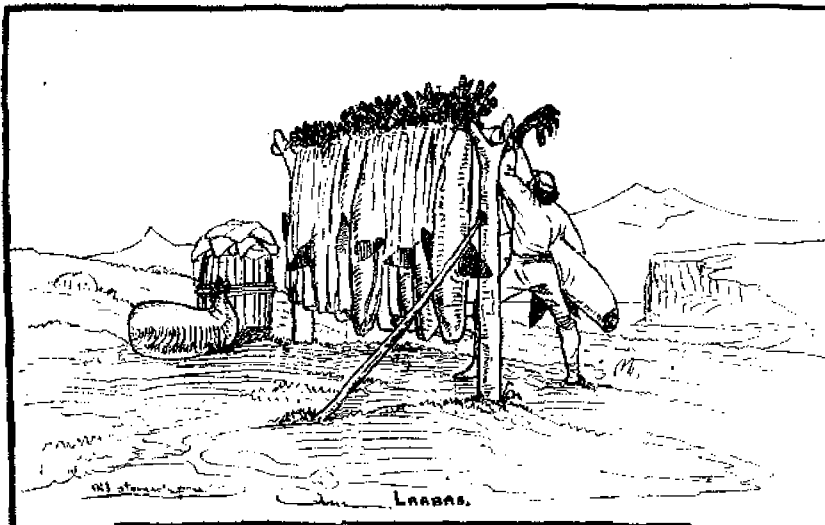

Sketches on St Paul.

THE SEA-LION HUNT ON PRIBYLOV ISLANDS.

Oil-pouch of sea-lion stomach; seal-meat frame; hidarral covered with sea-lion skins; scalers' houses. (Sect. v, vol. ii, pp. 471, 473.)

Drawing by H. W. Elliott.

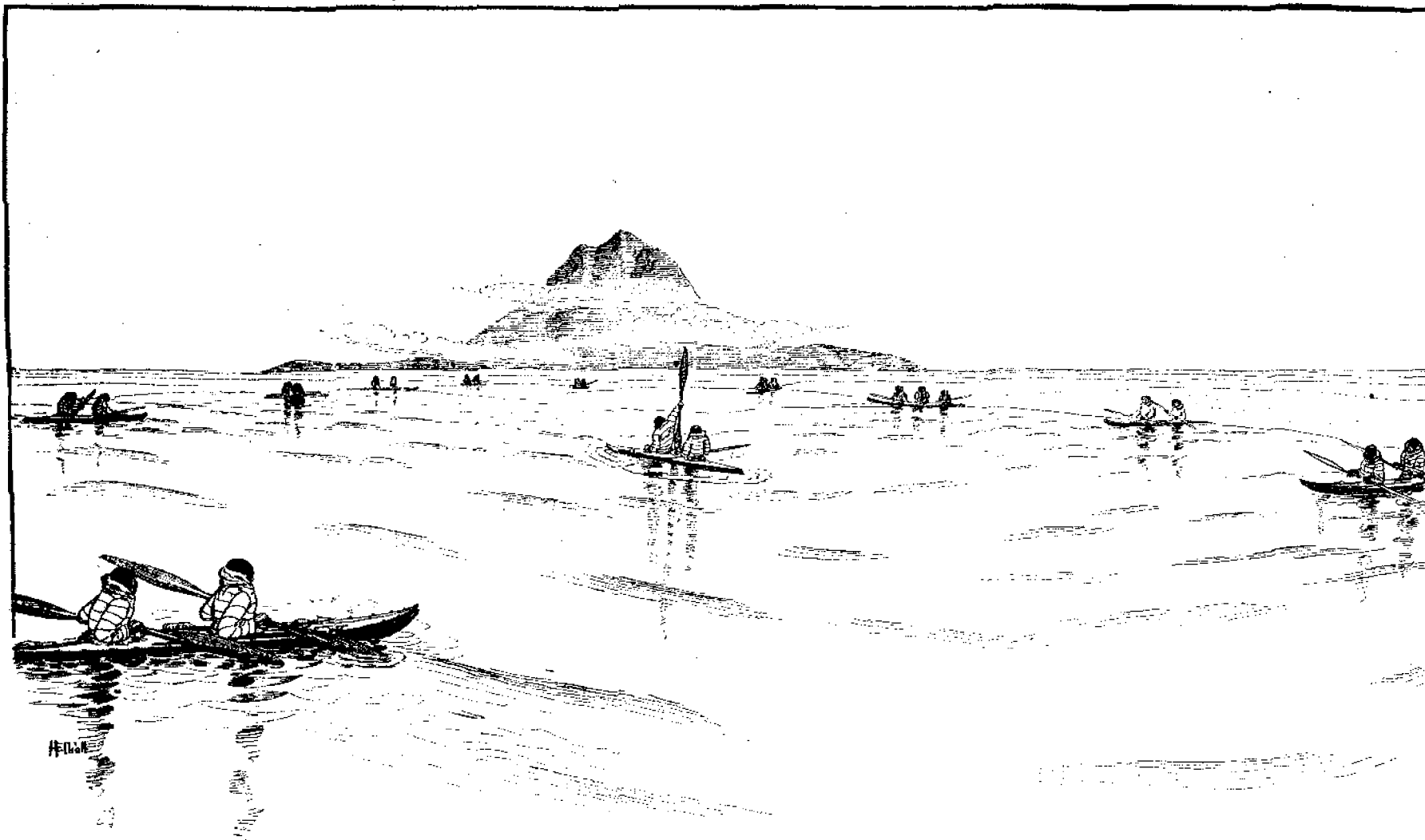

**THE SEA-OTTER FISHERY OF ALASKA.**

Alutians sea-otter hunting south of Saanak Island; the bidarkas waiting for the otter to rise again. (Seal. v, vol. ii, p. 490.)

Drawing by H. W. Elliott.

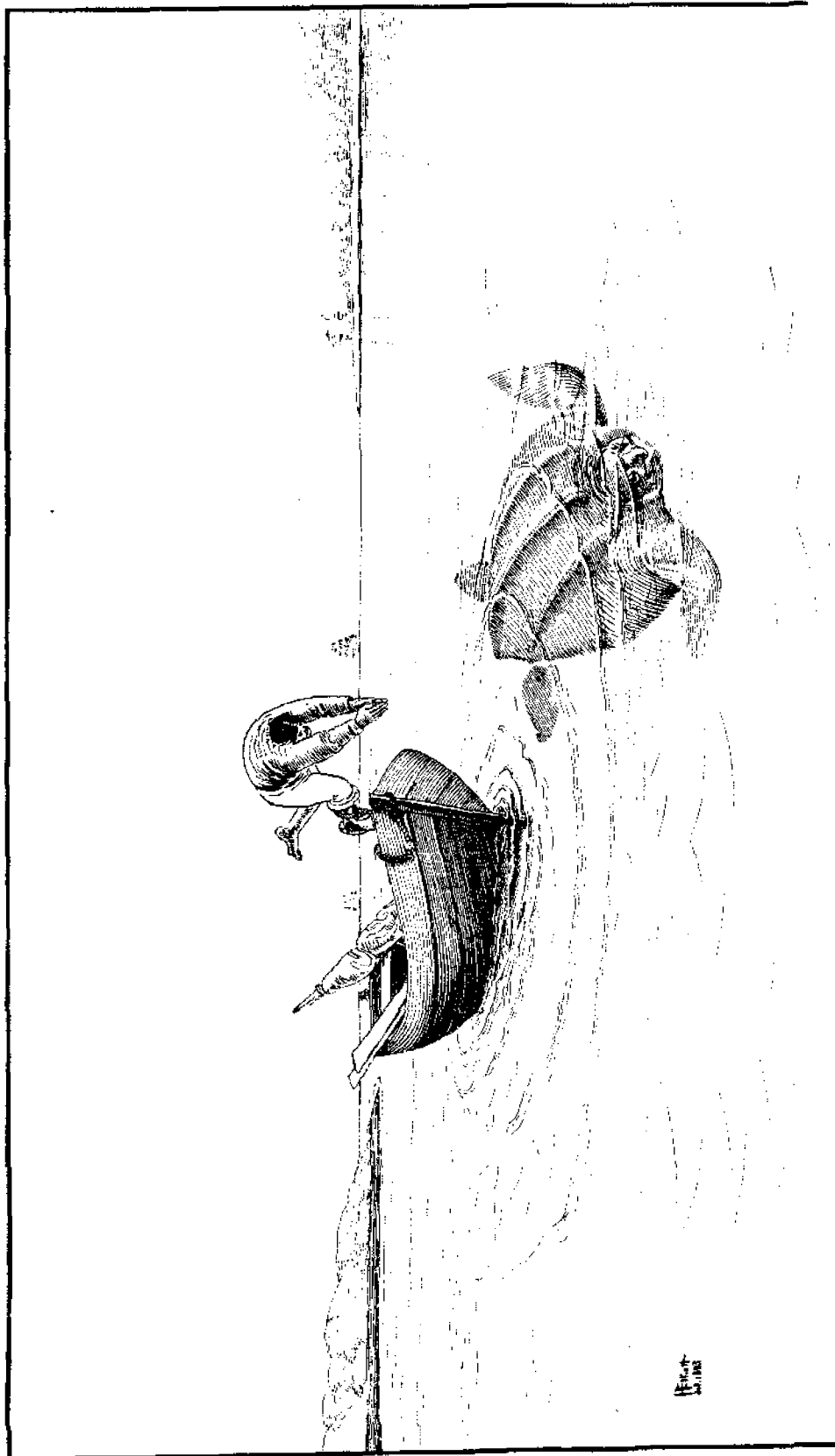

**THE TURTLE FISHERY.**

Diving for loggerhead turtle, Morehead City, North Carolina. (Sect. v, vol. ii, p. 485.)  
Drawing by H. W. Elliott.

H. W. Elliott  
1883

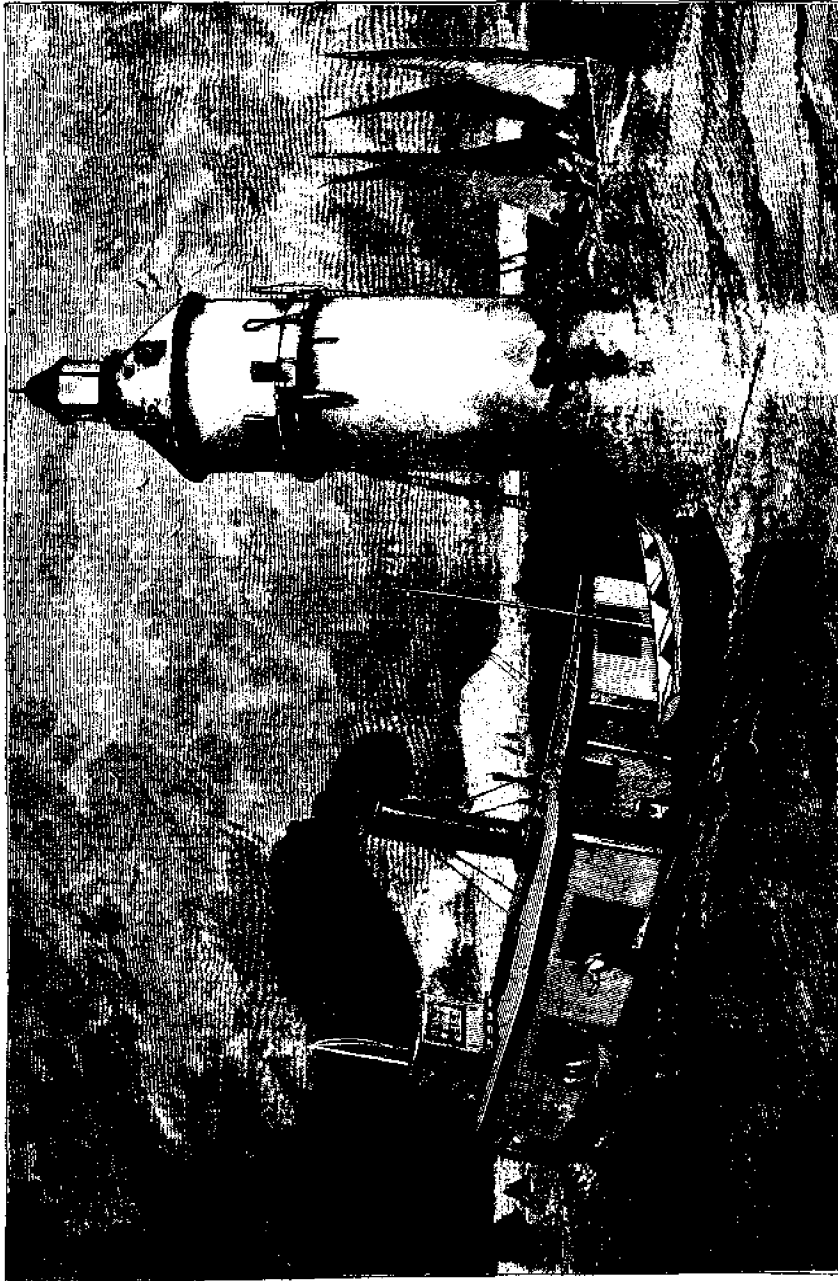

**THE OYSTER INDUSTRY.**

Oyster-dredging steamer at work in Long Island Sound. (Sect. v, vol. ii, pp. 523, 538.)

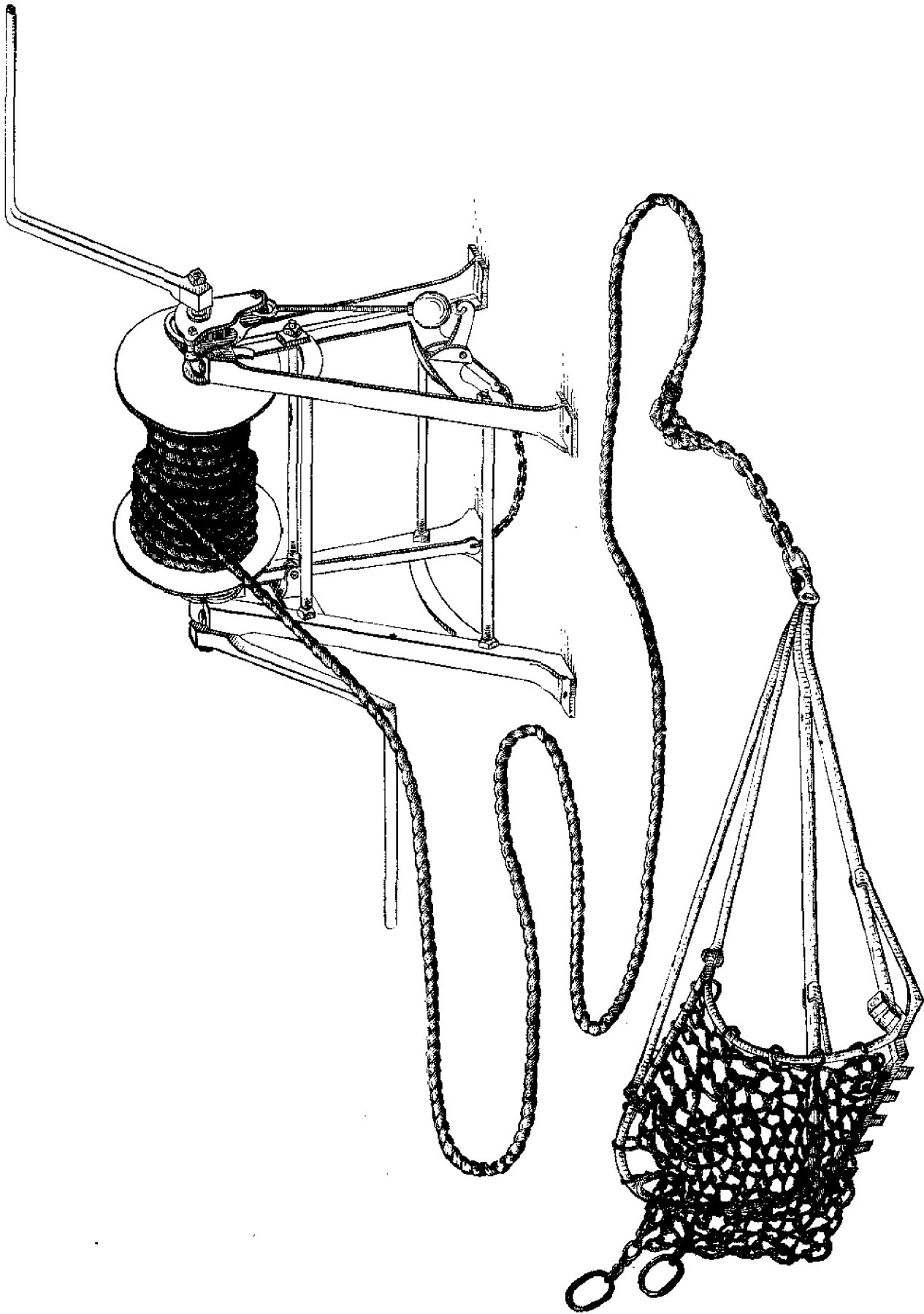

**THE OYSTER INDUSTRY.**

Chesapeake Bay oyster-dredge. (Sect. V, vol. ii, p. 523.)



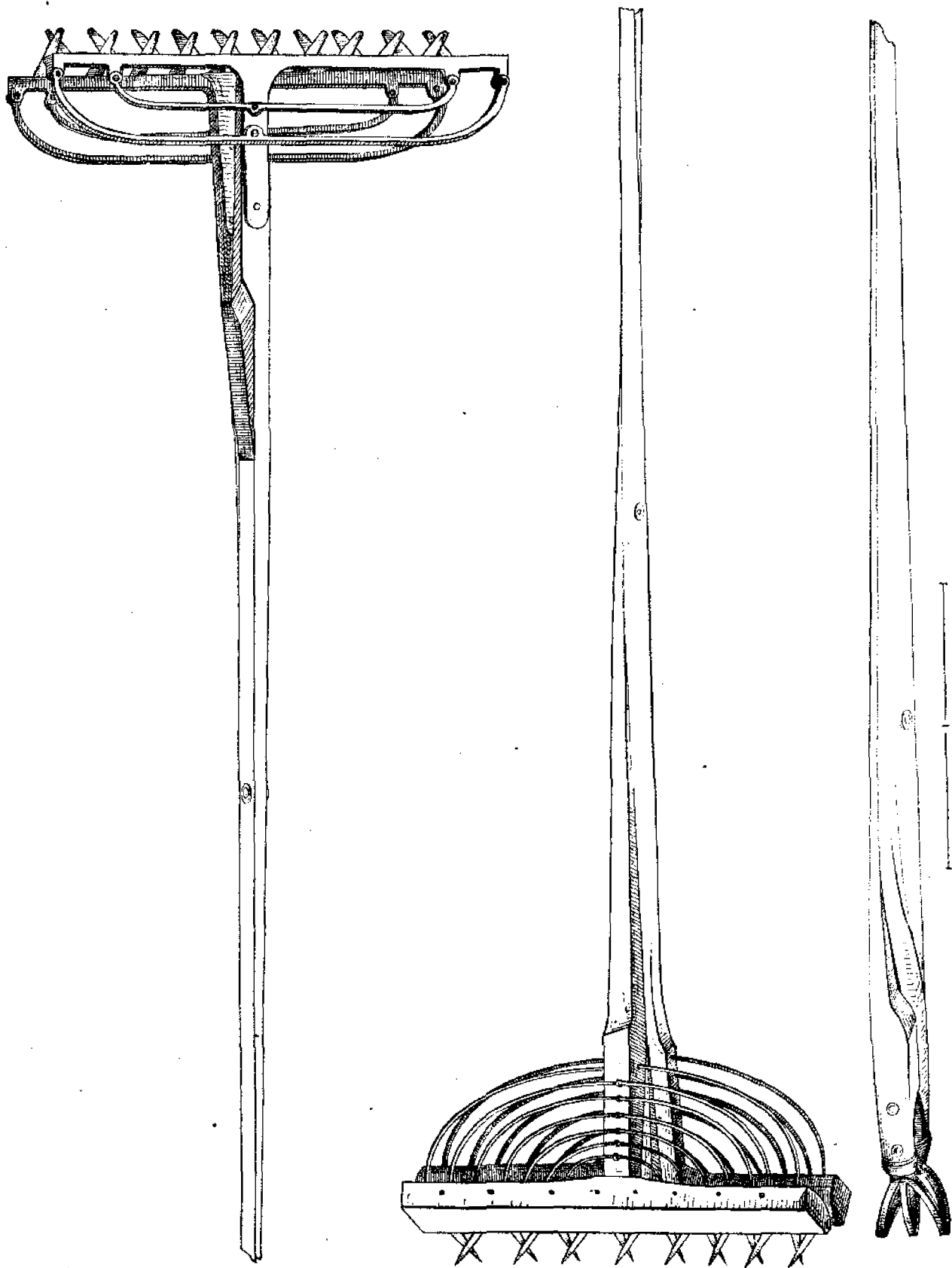

**THE OYSTER INDUSTRY.**

Oyster tongs and nippers. (Sect. v, vol. ii, p. 551.)



Fig. 1.



Fig. 2.

### THE OYSTER INDUSTRY.

FIG. 1. Inclosed dock for oyster-vessels at Perth Amboy, N. J. (Sect. v, vol. ii, p. 546.)

FIG. 2. "The Creek" at Keyport, N. J., with oyster-boats, skiffs, and scows. (Sect. v, vol. ii, p. 546.)

Drawings by Ernest Ingersoll.

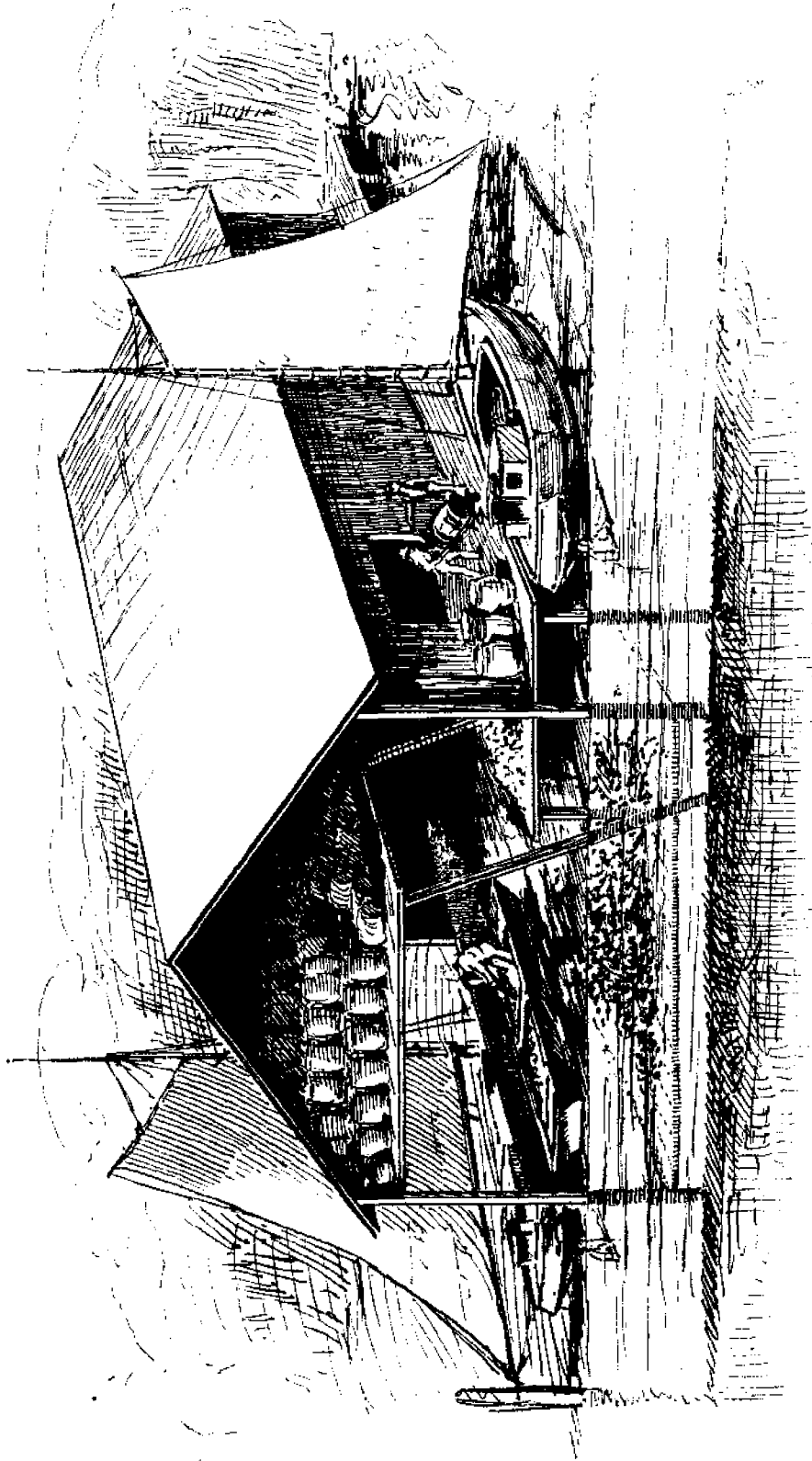

**THE OYSTER INDUSTRY.**

A Lake's Bay shipping-house and "platform" for freshening oysters, Smith's Landing, Lake's Bay, New Jersey. (Sect. v, vol. ii, p. 546.)

Drawing by Ernest Ingersoll.

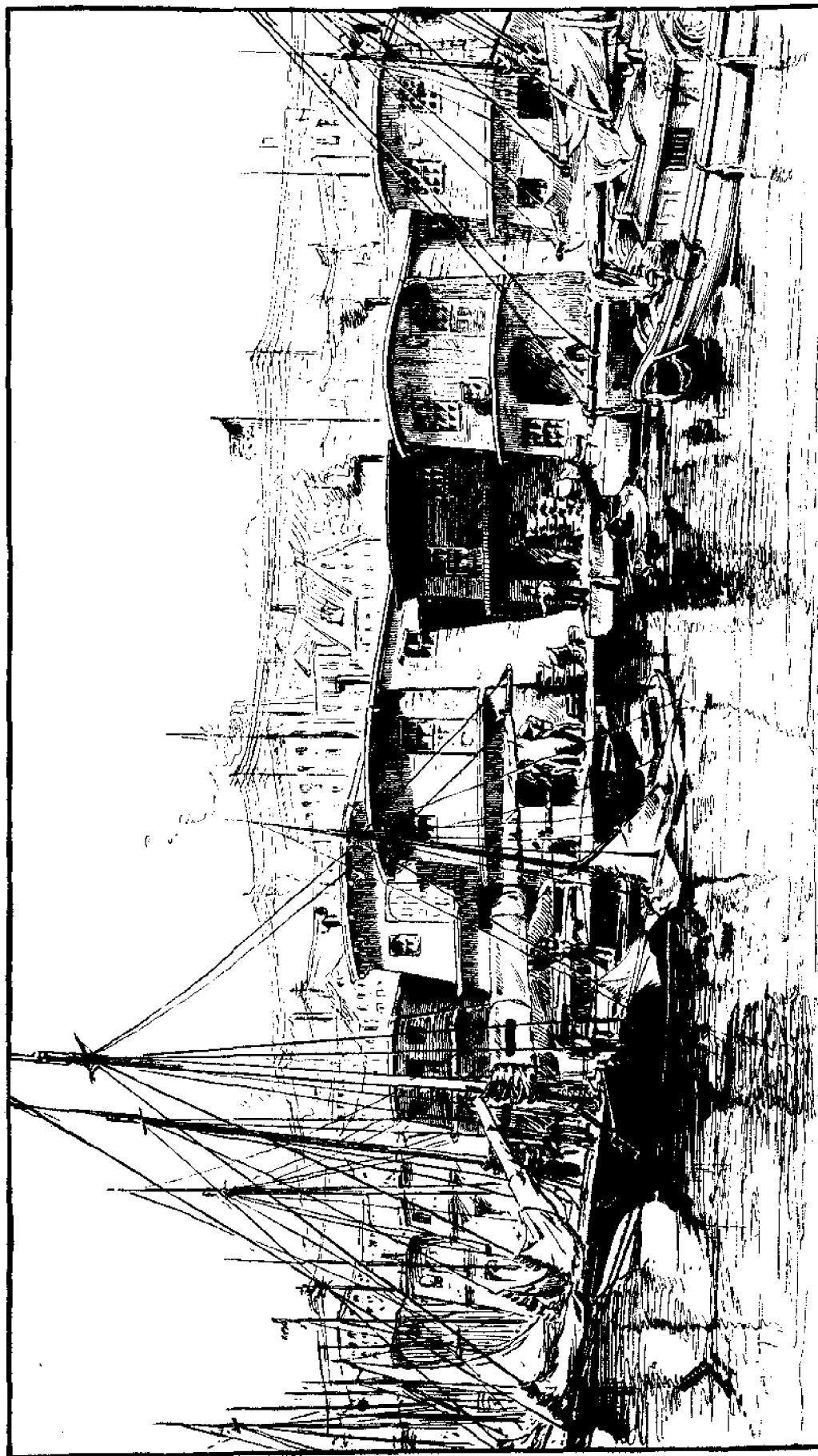

**THE OYSTER INDUSTRY.**

Oyster barges at the foot of West Tenth street, North River, New York City. (Sect. v, vol. ii, p. 555.)

Drawing by Ernest Ingersoll.

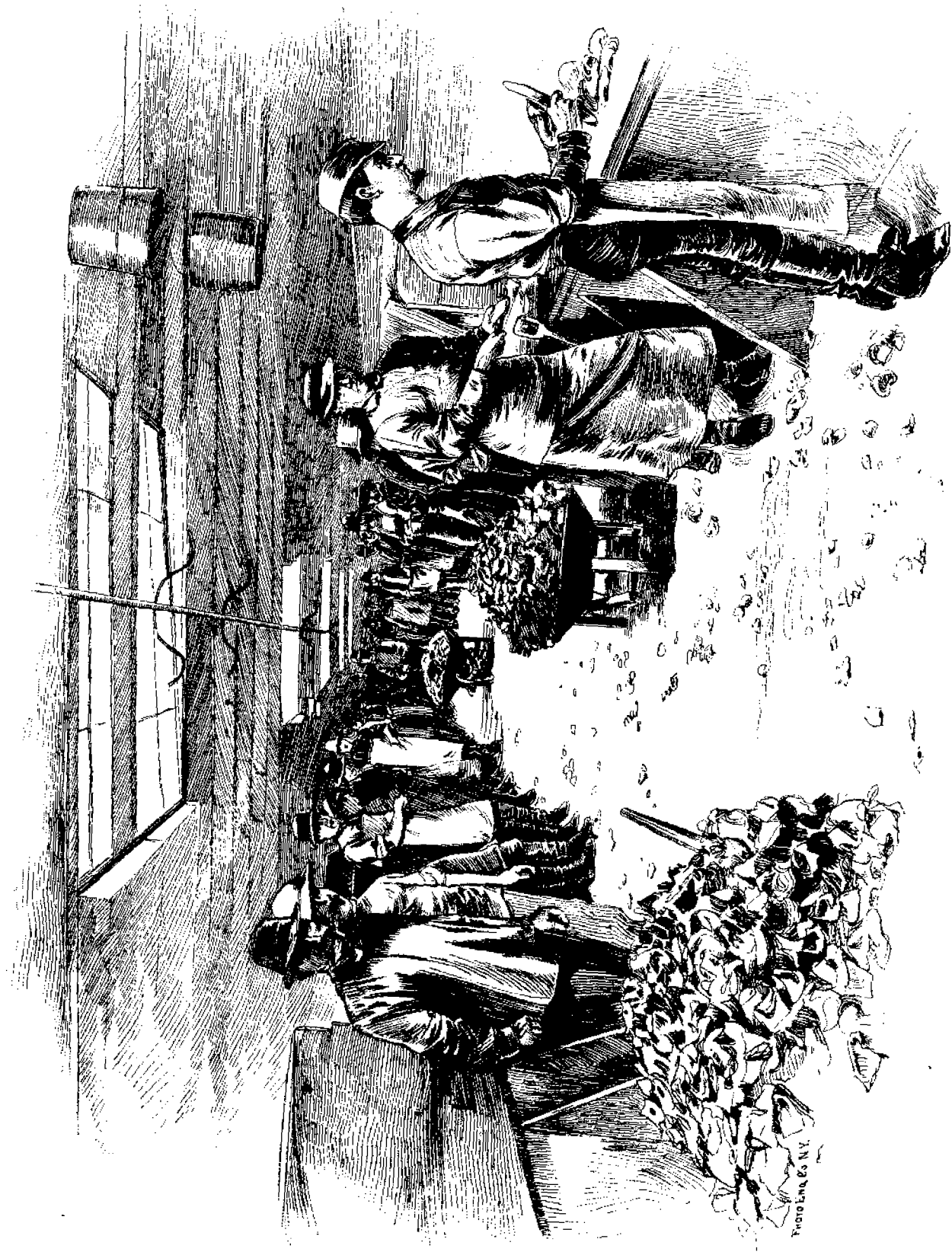
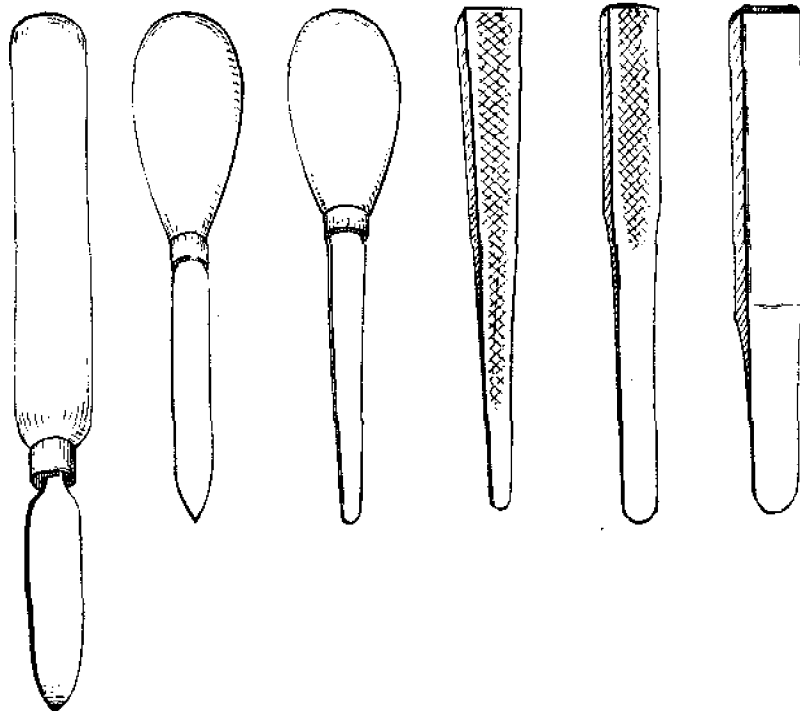
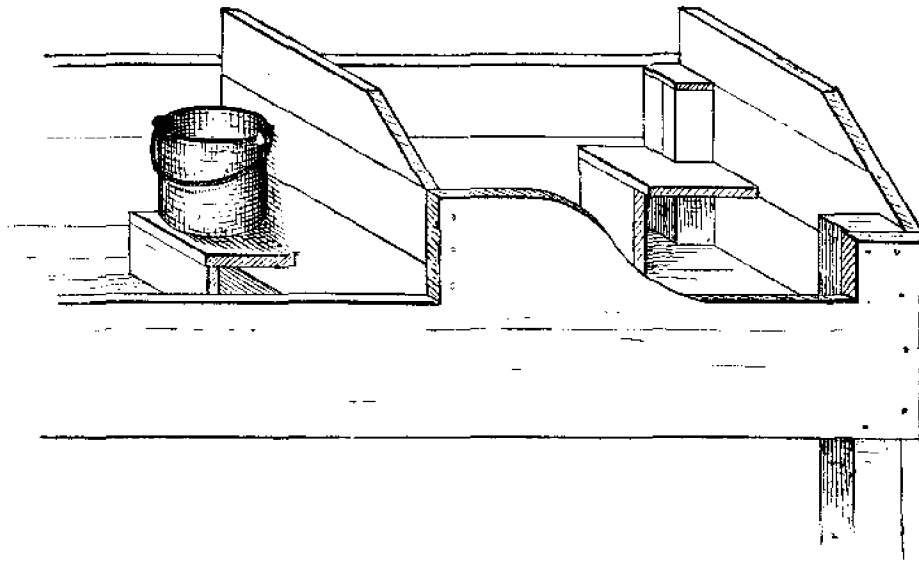

PHOTO LIND & CO. N.Y.

**THE OYSTER INDUSTRY.**

Opening or shucking oysters in a Baltimore packing-house. (Sect. v, vol. ii, p. 560.)  
From a photograph.



**THE OYSTER INDUSTRY.**

Baltimore oyster-shucking trough; oyster-knives of diverse patterns, used in New England, New York, and the Chesapeake region. (Sect. v, vol. ii, p. 559.)

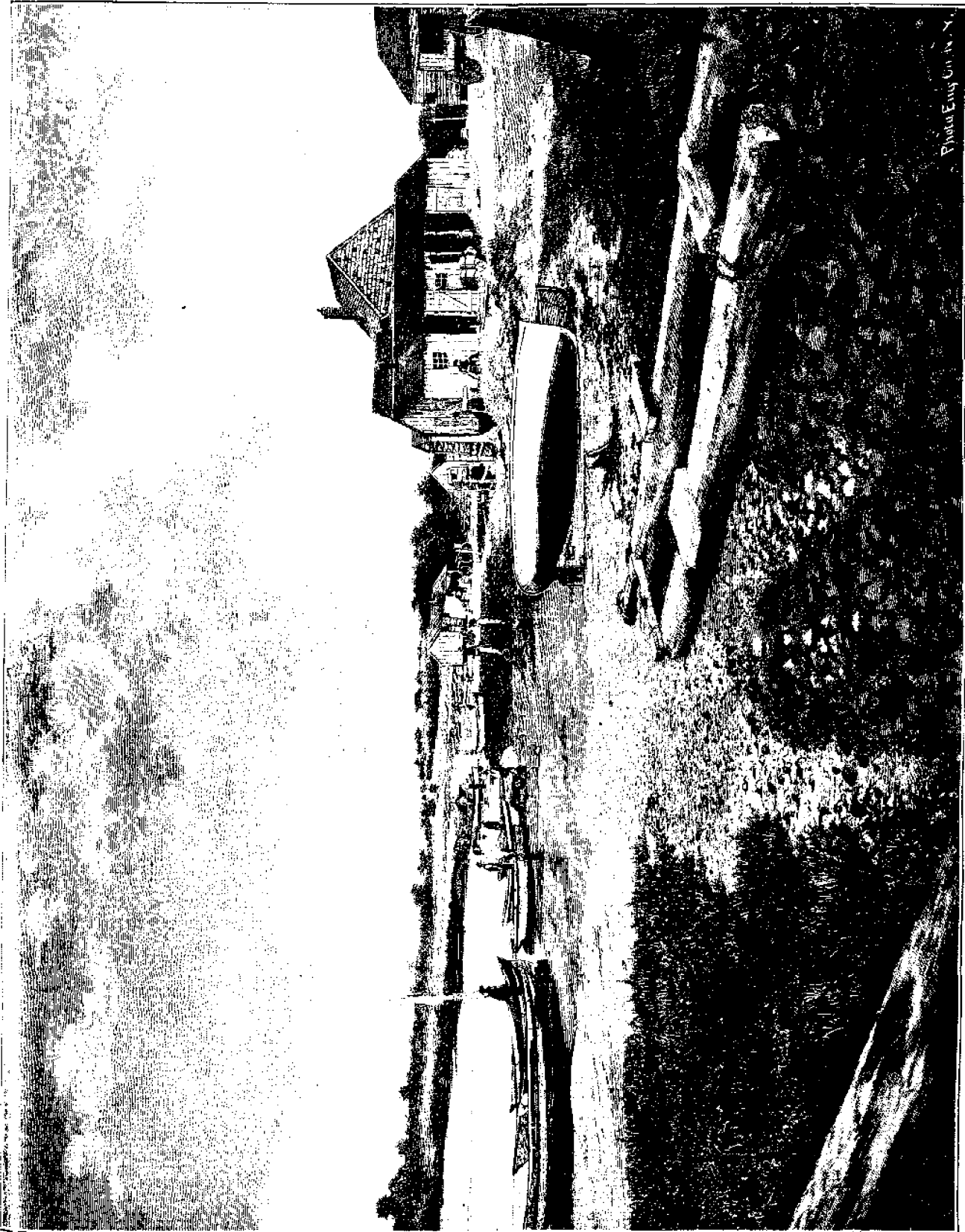

Photo Eng. Co. N. Y.

**THE CLAM INDUSTRY.**

Clam-diggers' boats and shucking-houses at Essex, Mass. (Seet. V. vol. II, p. 156.)

From a photograph by T. W. Siedler.



**THE CLAM INDUSTRY.**

Opening or shucking clams at Essex, Mass. (Seal, v. vol. II, p. 585.)

From a photograph by T. W. Shillie.



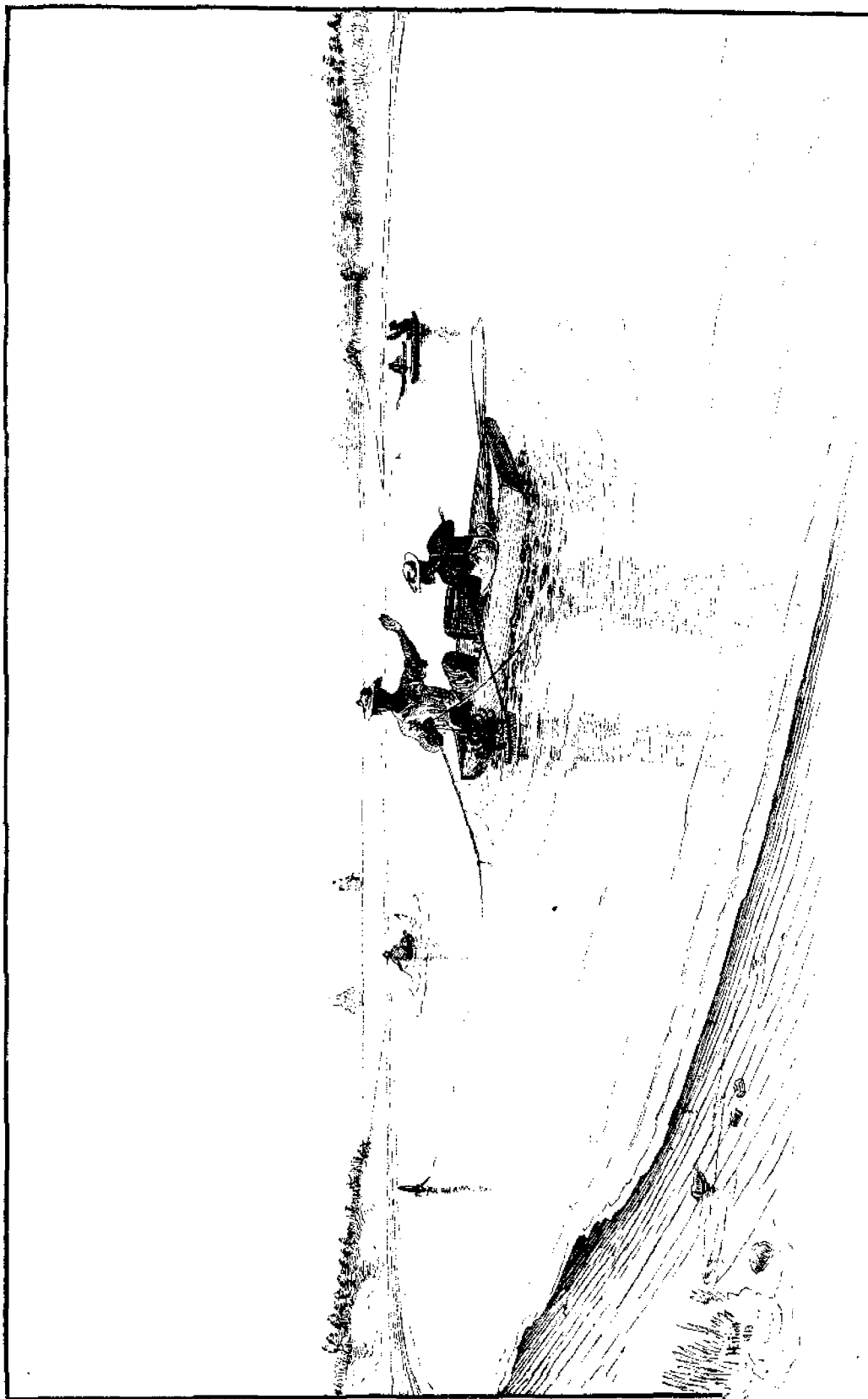

**THE CRAB FISHERY.**

Negroes trawling for crabs on the Virginia and North Carolina coasts. (Sect. v. vol. ii. p. 633.)

Drawing by H. W. Elliott.

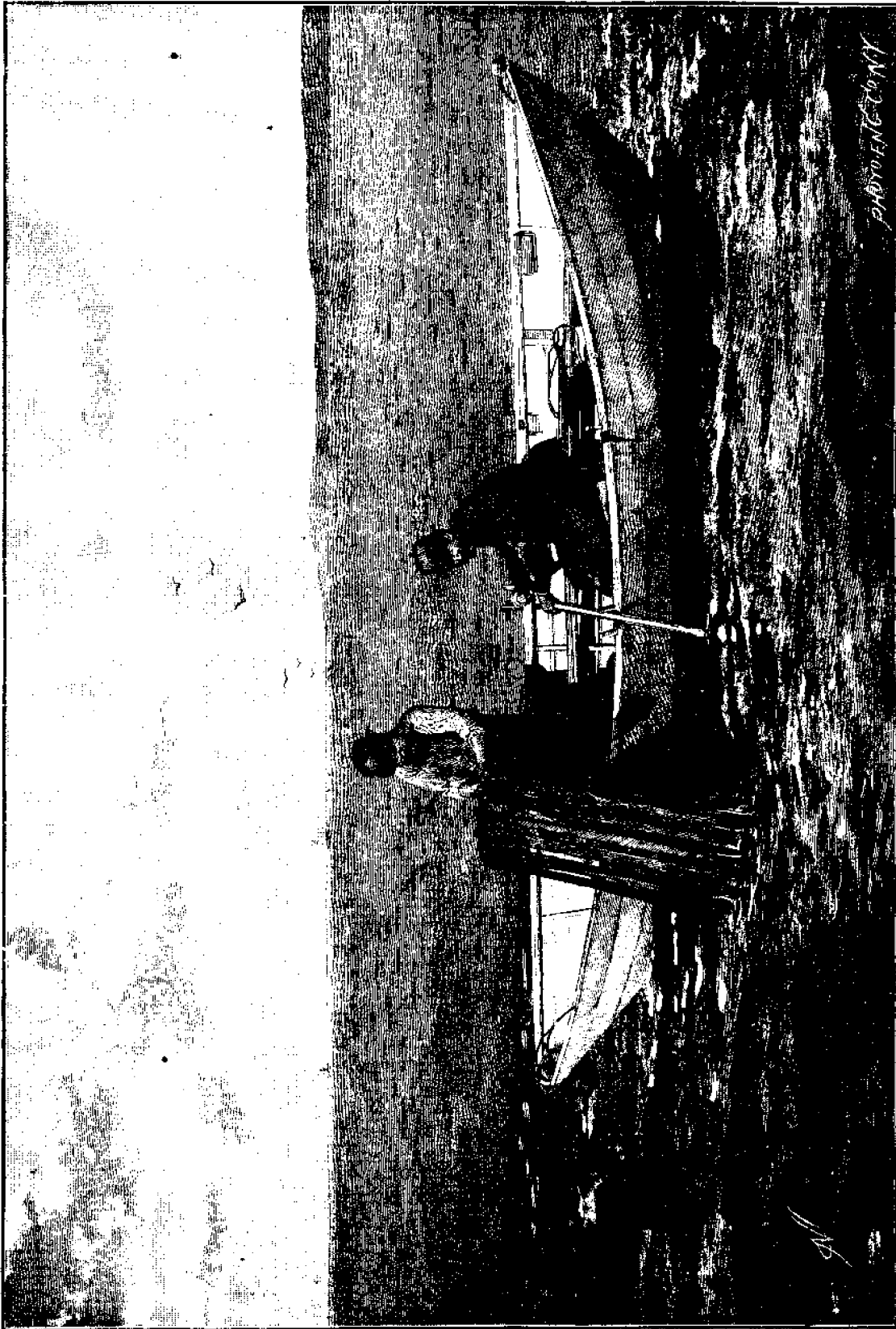

PHOTOGRAPH BY T. W. SMOULLEN

**THE LOBSTER FISHERY.**

Dory fishermen hauling lobster-pots off Cape Ann, Massachusetts. (Seal, v, vol. II, pp. 666, 667, 773.)

From a photograph by T. W. Smollic.

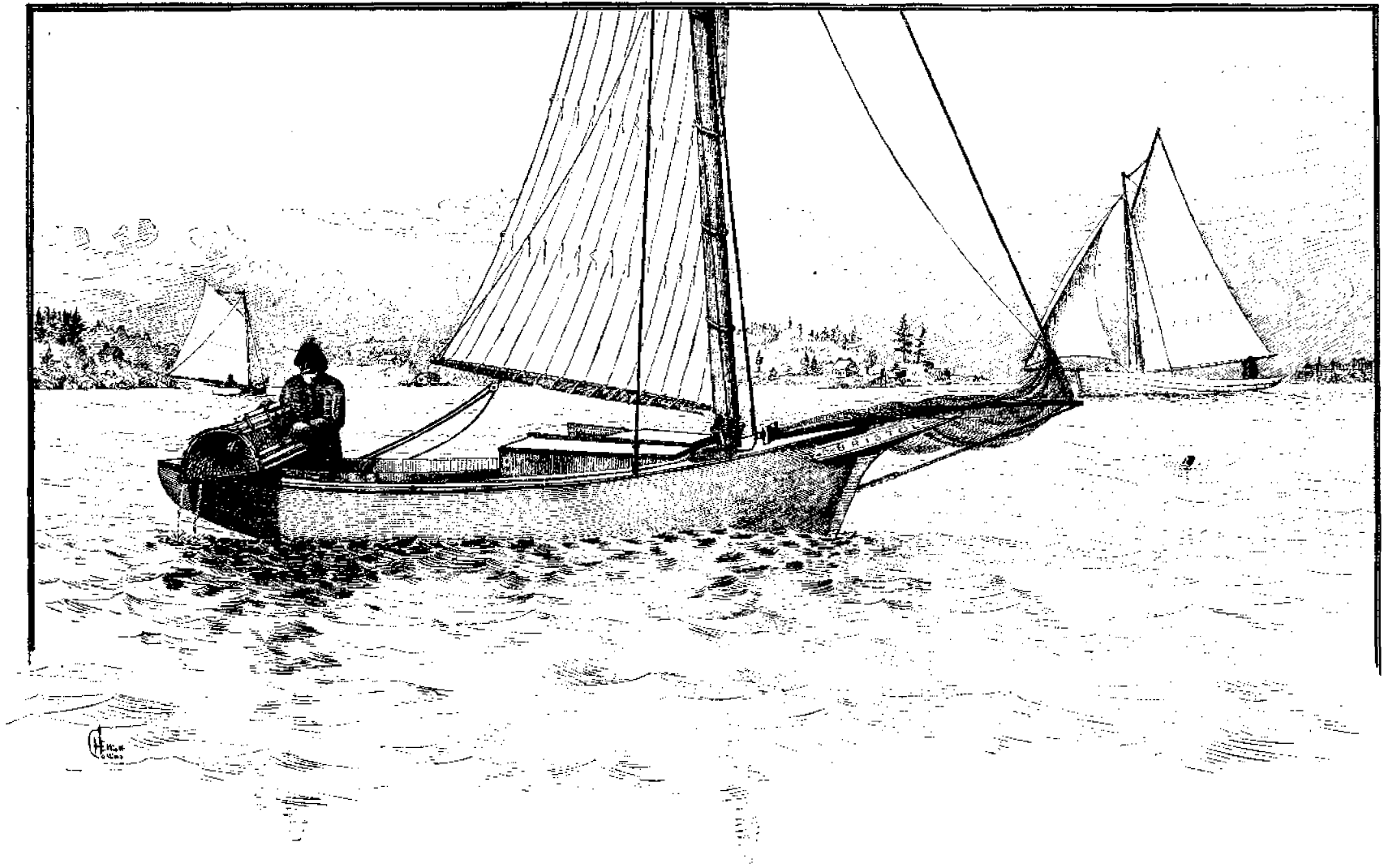

**THE LOBSTER FISHERY.**

Lobster fishing-boats of Bristol, Me. (Sect. v, vol. ii, pp. 669, 677, 759.)

Drawing by H. W. Elliott and Capt. J. W. Collins.

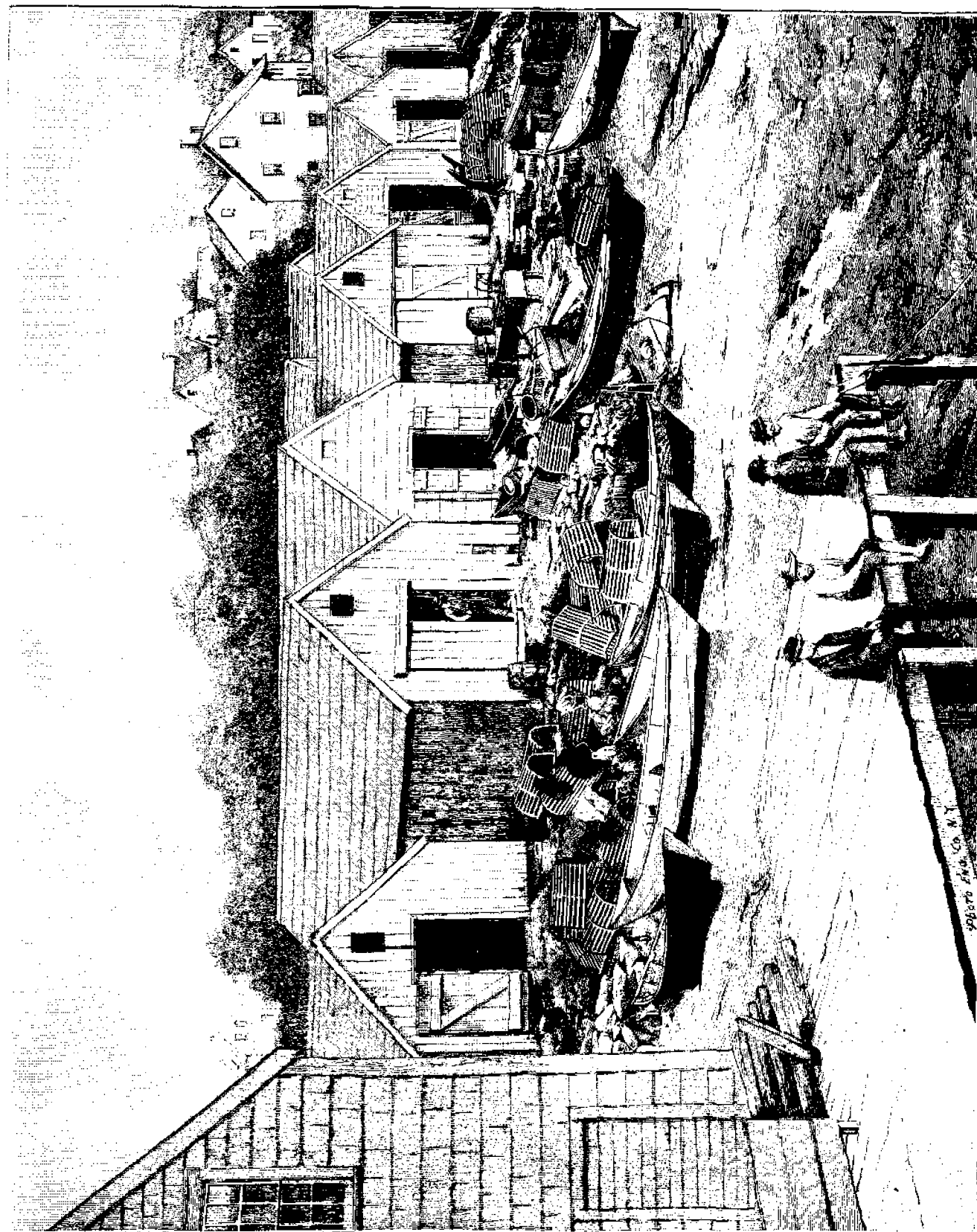

**THE LOBSTER FISHERY.**

Lobster cove at Lanesville, Cape Ann, Mass., showing boat houses and lobster-gear. (See, v, vol. ii, pp. 666, 773.)  
From a photograph by T. W. Scullie.

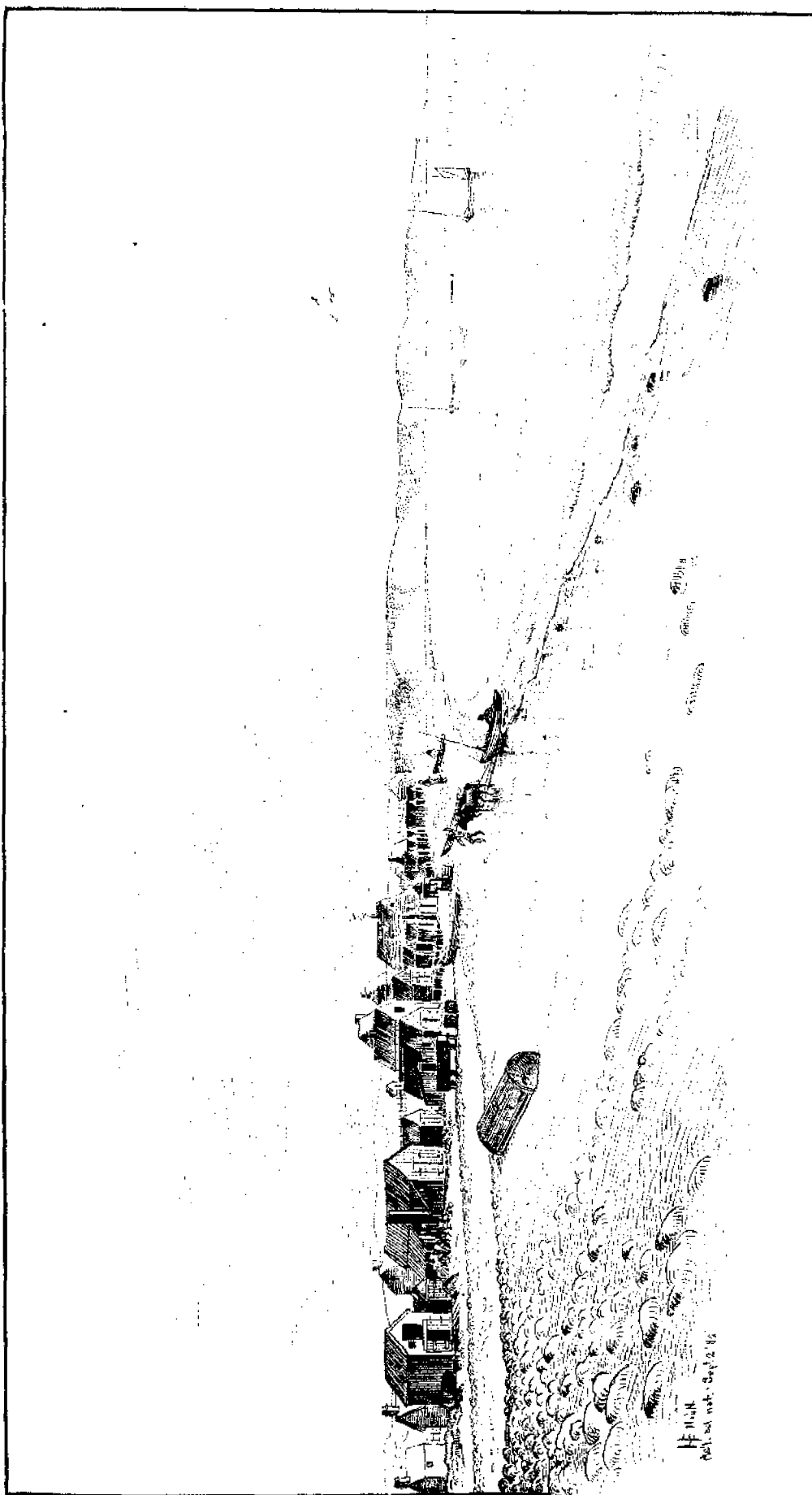

**THE LOBSTER FISHERY.**

Summer village of lobster fishermen at No Man's Land, Mass. (Sect. v, vol. ii, p. 751.)

Drawing by H. W. Elliott.

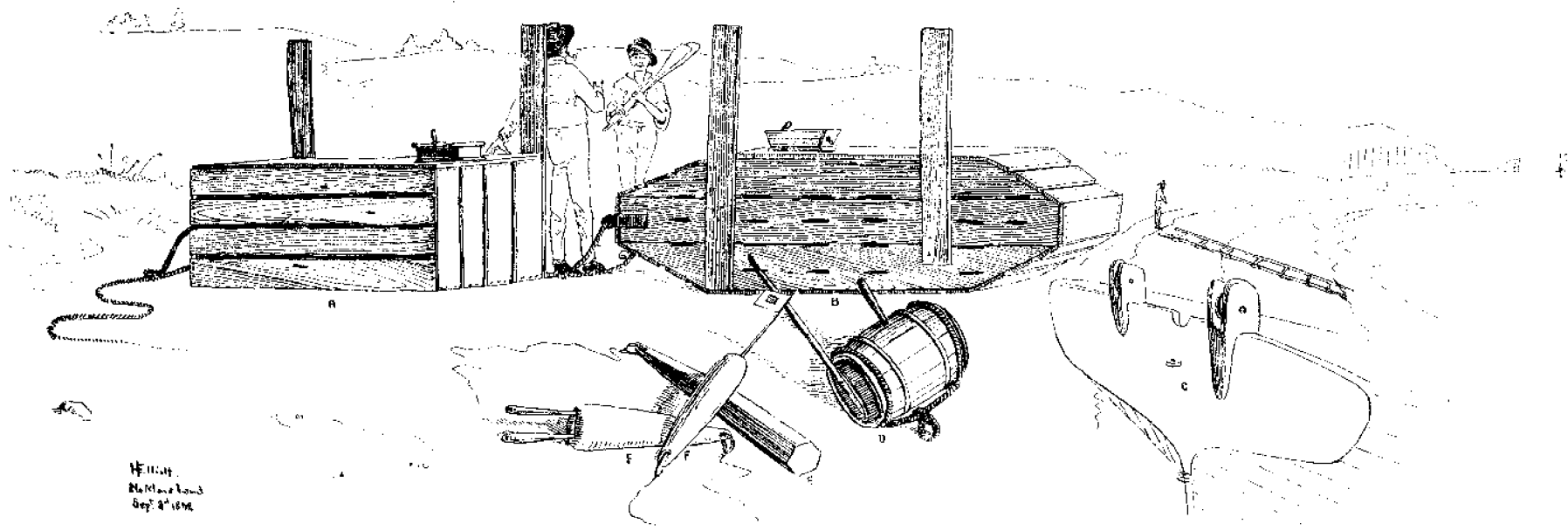

### THE LOBSTER FISHERY.

Lobster fishermen's gear at No Man's Land, Mass. (Sect. v, vol. ii, pp. 665, 672, 781.)

- A. Lobster car, common form.
- B. Lobster car for rough weather.
- C. Loggerheads, or line-rollers, for hoisting traps.

- D. Buoy for end line.
- E. Buoy for underrunning.
- F. Gay Head buoys.

Drawing by H. W. Elliott.

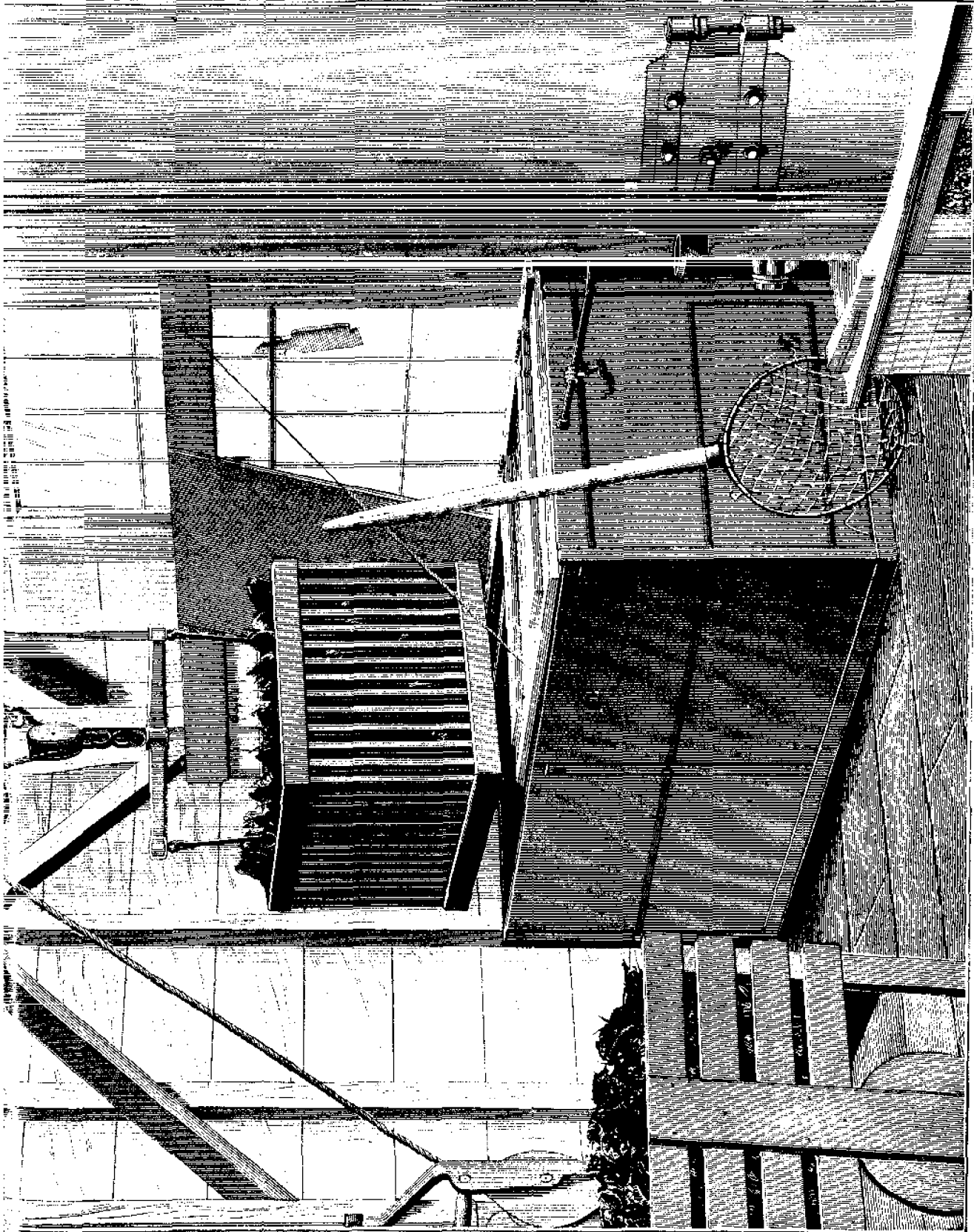

**THE LOBSTER INDUSTRY.**

Lobster-bowling apparatus at Portland, Me. (Seal. C. vol. iii. p. 68-1.)

From a photograph by T. W. Staffin.

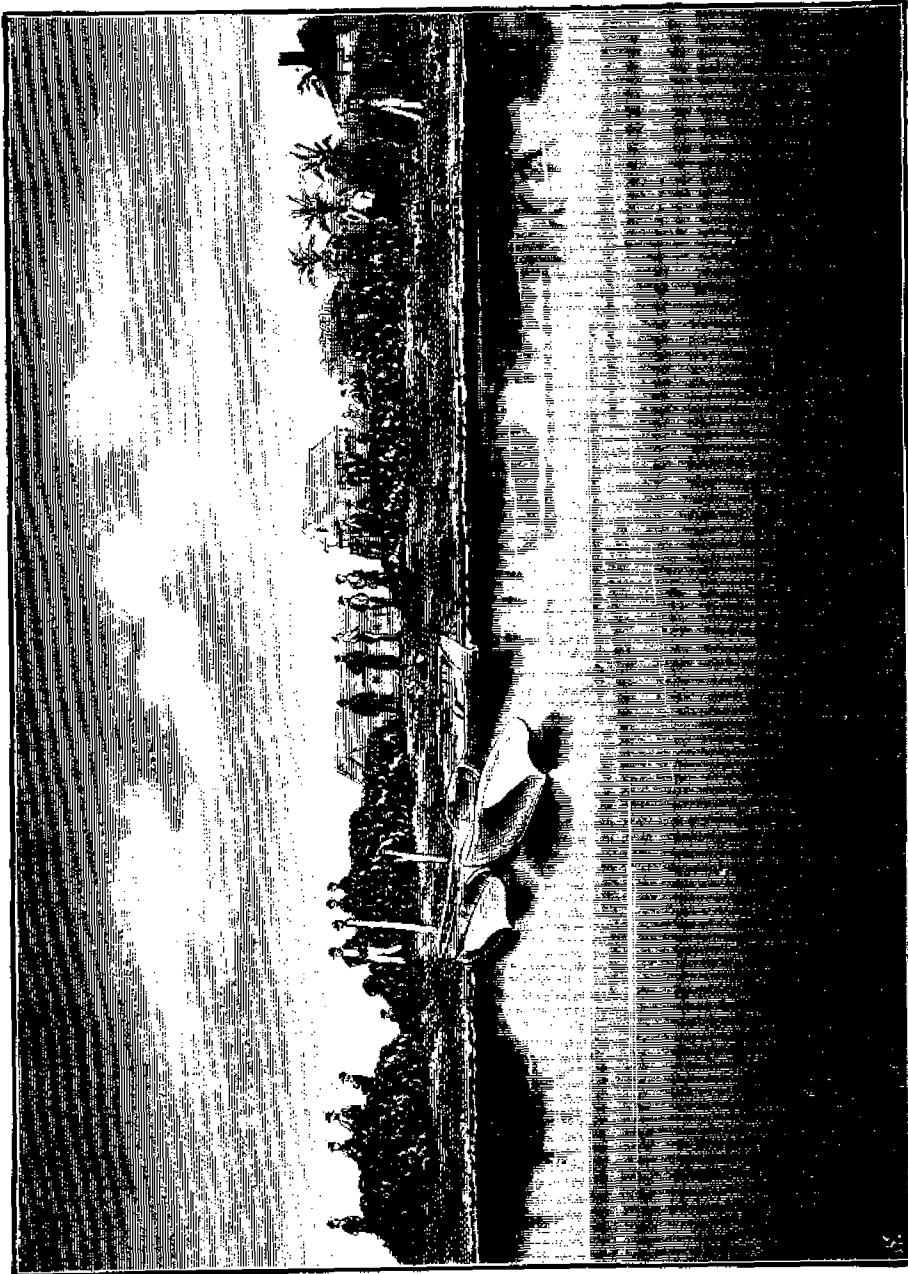

**THE SPONGE INDUSTRY.**

Sponges as landed by the fishermen at Key West, Fla., and ready for sale. (Soc. v, vol. ii, p. 295.)

From a photograph



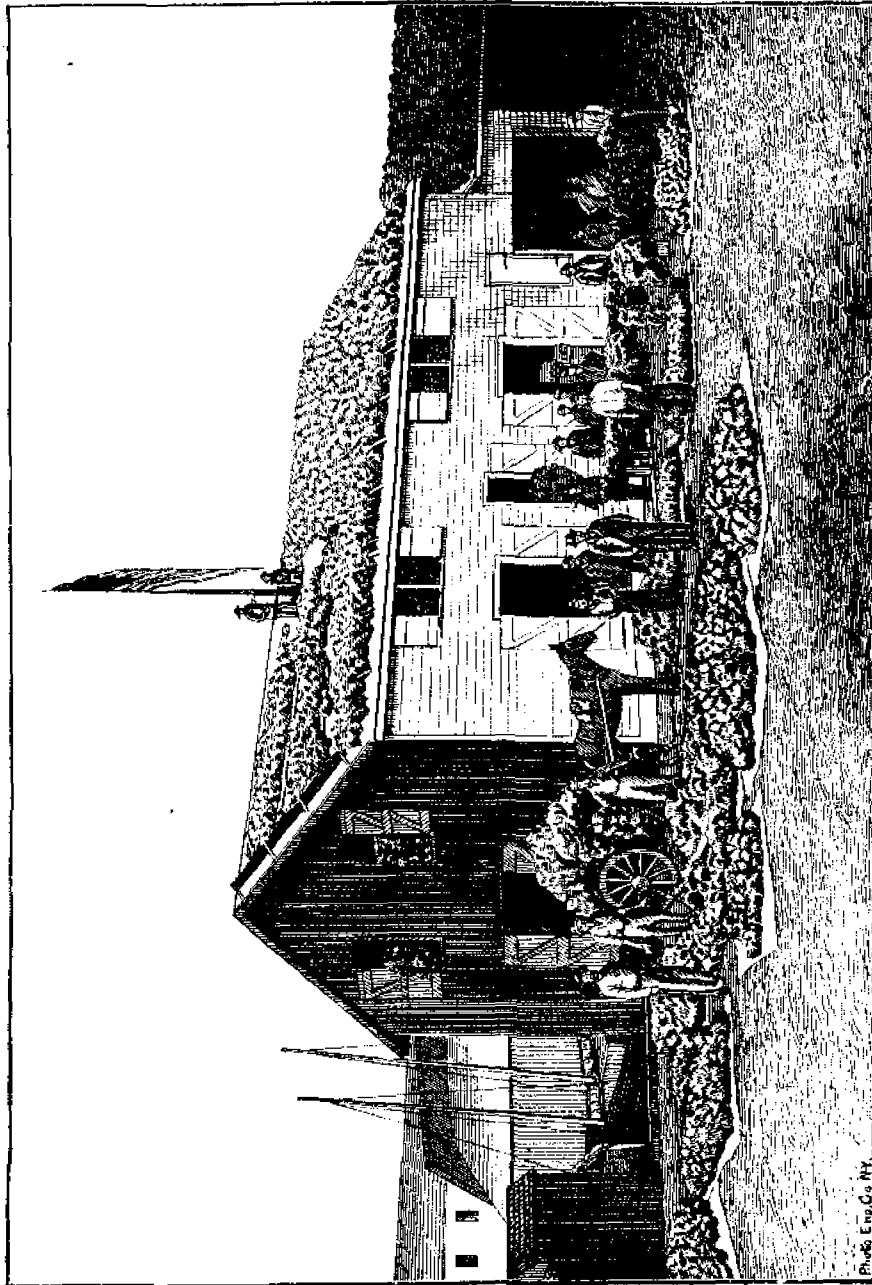

**THE SPONGE INDUSTRY.**

Sponge-loft at Key West, Fla. (Sect. V, vol. ii, p. 324.)

From a photograph.

Photo Eng. Co. N.Y.

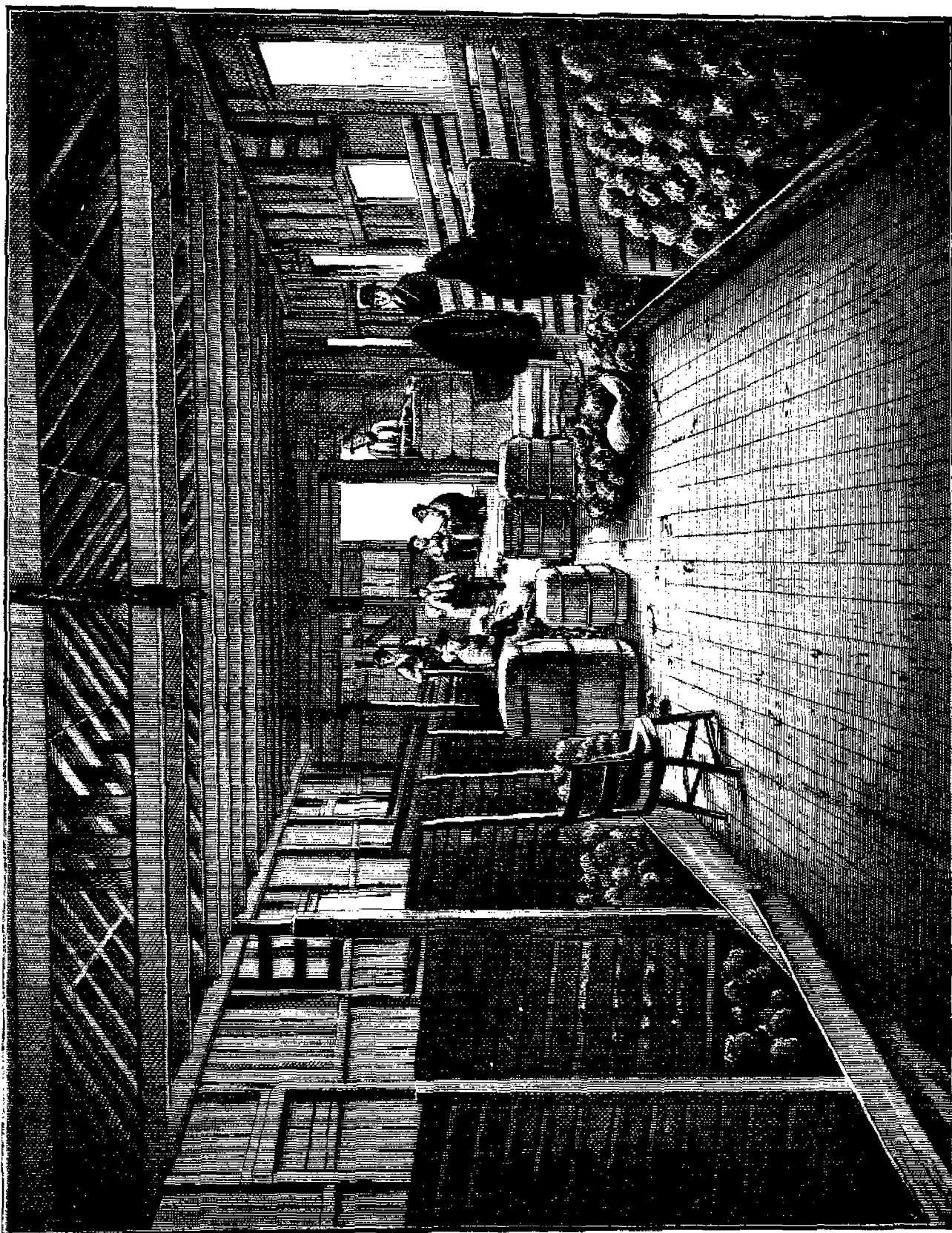

**THE SPONGE INDUSTRY.**

Sorting, trimming, and baling sponges at Key West, Fla. (Sect. V, vol. II, p. 225.)  
From a photograph.