



U.S. Department  
of Transportation

**Research and  
Special Programs  
Administration**

**USPS-  
DOT-VNTSC-USPS-96-1**

# Noise Characterization Study of the AP.1-88 Hovercraft



Environmental Policy  
and Management

**Final Report  
June 1996**

U.S. Postal Service  
Environmental Policy & Management  
475 L'Enfant Plaza, SW  
Washington, D.C. 20260-7133

U.S. Department of Transportation  
John A. Volpe National  
Transportation Systems Center  
Acoustics Facility, DTS-75  
Cambridge, MA 02142-1093

through the National Technical Information  
Service, Springfield, VA 22161

NCTICE

This document is disseminated under the sponsorship of the Department of Transportation in the interest of information exchange. The United States Government assumes no liability for its contents or use thereof.

NCTICE

The United States Government does not endorse products or manufacturers. Trade or manufacturers' names appear herein solely because they are considered essential to the object of this report.

**REPORT DOCUMENTATION PAGE**Form Approved  
OMB No. 0704-0188

Public reporting burden for this collection of information is estimated to average 1 hour per response, including the time for reviewing instructions, searching existing data sources, gathering and maintaining the data needed, and completing and reviewing the collection of information. Send comments regarding this burden estimate or any other aspect of this collection of information, including suggestions for reducing this burden, to Washington Headquarters Services, Directorate for information Operations and Reports, 1215 Jefferson Davis Highway, Suite 1204, Arlington, VA 22202-4302, and to the Office of Management and Budget, Paperwork Reduction Project (0704-0188), Washington, DC 20503.

1. AGENCY USE ONLY (Leave blank)		2. REPORT DATE June 1996	3. REPORT TYPE AND DATES COVERED Final Report June 1995 - June 1996	
4. TITLE AND SUBTITLE NOISE CHARACTERIZATION STUDY OF THE AP.1-88 HOVERCRAFT			5. FUNDING NUMBERS VR663/N6083	
6. AUTHOR(S) Christopher J. Roof, Gregg G. Fleming, David R. Read				
7. PERFORMING ORGANIZATION NAME(S) AND ADDRESS(ES) U.S. Department of Transportation Research and Special Programs Administration John A. Volpe National Transportation Systems Center Acoustics Facility, DTS-75 Kendall Square Cambridge, MA 02142-1093			8. PERFORMING ORGANIZATION REPORT NUMBER DOT-VNTSC-USPS-96-1	
9. SPONSORING/MONITORING AGENCY NAME(S) AND ADDRESS(ES) U.S. Postal Service Office of Environmental Policy & Management 475 L'Enfant Plaza, SW Washington, D.C. 20260-7133			10. SPONSORING/MONITORING AGENCY REPORT NUMBER ????	
11. SUPPLEMENTARY NOTES U.S. Postal Service Program Manager: Charlie Bravo, Office of Environmental Policy and Management; U.S. Postal Service Logistics Contact: Yvonne DaCunha Wecker, Routing Policy and Networks.				
12a. DISTRIBUTION/AVAILABILITY STATEMENT This document is available to the public through the National Technical Information Service, Springfield, VA 22161			12b. DISTRIBUTION CODE	
13. ABSTRACT (Maximum 200 words) During the period, June 1995 through March 1996, the U.S. Department of Transportation, Research and Special Programs Administration, John A. Volpe National Transportation Systems Center (Volpe Center), Acoustics Facility, in support of the United States Postal Service (Postal Service) Office of Environmental Policy & Management, conducted a Noise Characterization Study of the British Hovercraft Corporation Model AP.1-88 Hovercraft (AP.1-88). This document presents the results of the study, including the measurement, data reduction and analysis procedures used to characterize the craft. Also presented, for the purpose of comparison with the AP.1-88 noise data, is a limited amount of measured noise data for the Textron Marine & Land Systems Lighter Air Cushion Vehicle-30 (LACV-30) hovercraft.				
14. SUBJECT TERMS Noise, Hovercraft, Noise Measurement, Acoustic, Alaska, Air Cushion Vehicle, AP.1-88, LACV-30, Bethel, United States Postal Service			15. NUMBER OF PAGES 76	
			16. PRICE CODE	
17. SECURITY CLASSIFICATION OF REPORT Unclassified	18. SECURITY CLASSIFICATION OF THIS PAGE Unclassified	19. SECURITY CLASSIFICATION OF ABSTRACT Unclassified	20. LIMITATION OF ABSTRACT Unlimited	

## PREFACE

During the period, June 1995 through March 1996, the U.S. Department of Transportation, Research and Special Programs Administration, John A. Volpe National Transportation Systems Center (Volpe Center), Acoustics Facility, in support of the United States Postal Service (Postal Service) Office of Environmental Policy & Management, conducted a Noise Characterization Study of the British Hovercraft Corporation Model AP.1-88 Hovercraft (AP.1-88). This document presents the results of the study, including the measurement, data reduction and analysis procedures used to characterize the craft. Also presented, for the purpose of comparison with the AP.1-88 noise data, is a limited amount of measured noise data for the Textron Marine & Land Systems Lighter Air Cushion Vehicle-30 (LACV-30) hovercraft.

Special thanks are in order for several individuals whose hard work contributed significantly towards the completion of this project. Yvonne DaCunha Wecker, of the Postal Service Routing Policy and Networks Office in Washington D.C., provided insightful managerial guidance in all aspects of this project. Tom Rutledge, of the Postal Service Western Area DNO Seattle Branch, aided in the day-to-day logistical details of the project as well as provided photographic documentation of the testing for this document. Phil Mattson, Mike Dyer and Ruth Potter of the Volpe Center Environmental Engineering Division provided invaluable project coordination and Jim Stewart of Alaska Hovercraft in Anchorage acted as technical contact with regards to hovercraft mechanical / maneuverability issues.

Additionally, Bill Bowlby of Bowlby and Associates, Inc., provided snowmobile noise data which was used for characterizing hovercraft noise levels in terms of vehicles that are commonly found on the Alaskan Peninsula.

Successful completion of this project would not have been possible without the assistance of the aforementioned individuals. The authors extend their deepest gratitude.

**TABLE OF CONTENTS**

<u>SECTION</u>	<u>PAGE</u>
1. INTRODUCTION . . . . .	1
1.1 BACKGROUND . . . . .	1
1.2 OBJECTIVE . . . . .	2
1.3 TEST HOVERCRAFT . . . . .	2
1.4 TEST SITE . . . . .	4
2. MEASUREMENT INSTRUMENTATION . . . . .	7
2.1 ACOUSTIC INSTRUMENTATION . . . . .	7
2.2 SUPPORT INSTRUMENTATION . . . . .	9
2.2.1 Meteorological Instrumentation . . . . .	9
2.2.2 Communication Instrumentation . . . . .	10
2.2.3 Hovercraft Guidance/Tracking Instrumentation . . . . .	10
3. EXPERIMENTAL APPROACH . . . . .	11
3.1 TEST SITE . . . . .	11
3.2 MICROPHONE LOCATIONS . . . . .	12
3.3 TEST PROCEDURES . . . . .	13
4. DATA REDUCTION AND ANALYSIS . . . . .	17
4.1 ON-LINE NOISE DATA . . . . .	17
4.2 METEOROLOGICAL DATA . . . . .	17
4.3 TRACKING DATA . . . . .	18
4.4 DIGITALLY-RECORDED NOISE DATA . . . . .	18
4.4.1 Background Noise . . . . .	19
4.4.2 Frequency Response Correction . . . . .	21
4.4.3 Spectral Shaping . . . . .	21
4.4.4 Simulation of "Slow-Scale" Exponential Time Constant . . . . .	22
4.4.5 As-Measured Noise Descriptor Computations	23

**TABLE OF CONTENTS (continued)**

<u>SECTION</u>	<u>PAGE</u>
4.5 CORRECTIONS TO REFERENCE CONDITIONS - SIMPLIFIED PROCEDURE . . . . .	23
4.5.1 Simplified Correction Procedure . . . . .	24
5. DISCUSSION OF RESULTS . . . . .	29
5.1 PASS-BY DATA . . . . .	29
5.2 APPROACH/DEPARTURE DATA . . . . .	32
5.3 SPECTRAL DATA . . . . .	33
5.4 ASSESSMENT OF COMMUNITY NOISE IMPACT DUE TO HOVERCRAFT . . . . .	34
6. CONCLUSIONS . . . . .	37
APPENDIX A. PROPOSED MAIL DELIVERY SCHEDULE . . . . .	A-1
APPENDIX B. AS-MEASURED DATA . . . . .	B-1
APPENDIX C. CORRECTED PASS-BY DATA . . . . .	C-1
APPENDIX D. CORRECTED ONE-THIRD OCTAVE-BAND SPECTRAL DATA	D-1
APPENDIX E. ASSESSMENT OF COMMUNITY NOISE IMPACT DUE TO HOVERCRAFT . . . . .	E-1
APPENDIX F. STATEMENT OF HOVERCRAFT CONFIGURATION . . . . .	F-1
APPENDIX G. REFERENCES . . . . .	G-1
APPENDIX H. SUBJECT INDEX . . . . .	H-1

## LIST OF FIGURES

<u>FIGURE</u>	<u>PAGE</u>
1. The AP.1-88 Hovercraft . . . . .	3
2. The LACV-30 Hovercraft . . . . .	4
3. Noise Measurement Test Site . . . . .	5
4. Relative Location of Bethel and Anchorage . . . . .	5
5. Acoustic Instrumentation . . . . .	7
6. Test Site . . . . .	11
7. Pass-by Test Set-up . . . . .	12
8. Approach/Departure Test Set-up . . . . .	13
9. Acoustic Data Analysis Instrumentation . . . . .	18
10. Correction Process . . . . .	25
11. Pass-by Spectral Level Versus Frequency . . . . .	34
E-1. $L_{dn}$ or $L_{Aeq24h}$ vs. Distance - Pass-by . . . . .	E-5
E-2. $L_{dn}$ or $L_{Aeq24h}$ vs. Distance - Pass-by . . . . .	E-6
E-3. $L_{dn}$ or $L_{Aeq24h}$ vs. Distance - Approach/Departure . . . . .	E-7
E-4. $L_{dn}$ or $L_{Aeq24h}$ vs. Distance - Approach/Departure . . . . .	E-8



**LIST OF TABLES**

<u>TABLE</u>	<u>PAGE</u>
1. Summary of Tests . . . . .	29
2. Summary of AP.1-88 Pass-by Data . . . . .	31
3. Summary of LACV-30 Pass-by Data . . . . .	31
B1. As-Measured LD2900 Pass-by Data . . . . .	B-2
B2. As-Measured DAT Pass-by Data . . . . .	B-3
B3. As-Measured LD2900 Approach/Departure Data . . . . .	B-4
B4. As-Measured DAT Approach/Departure Data . . . . .	B-5
C1. AP.1-88 Pass-by Data - Overall, Average-Corrected .	C-2
C2. LACV-30 Pass-by Data - Overall, Average-Corrected .	C-2
C3. AP.1-88 Pass-by Data: Event 1L, 9/25/95 . . . . .	C-3
C4. AP.1-88 Pass-by Data: Event 2R, 9/25/95 . . . . .	C-3
C5. AP.1-88 Pass-by Data: Event 3L, 9/25/95 . . . . .	C-3
C6. AP.1-88 Pass-by Data: Event 7R, 9/25/95 . . . . .	C-3
C7. AP.1-88 Pass-by Data: Event 8L, 9/25/95 . . . . .	C-4
C8. AP.1-88 Pass-by Data: Event 9R, 9/25/95 . . . . .	C-4
C9. AP.1-88 Pass-by Data: Event 10L, 9/25/95 . . . . .	C-4
C10. AP.1-88 Pass-by Data: Event 11R, 9/25/95 . . . . .	C-4
C11. AP.1-88 Pass-by Data: Event 13R, 9/25/95 . . . . .	C-5
C12. AP.1-88 Pass-by Data: Event 14L, 9/25/95 . . . . .	C-5
C13. AP.1-88 Pass-by Data: Event 17L, 9/25/95 . . . . .	C-5
C14. AP.1-88 Pass-by Data: Event 18R, 9/25/95 . . . . .	C-5
C15. AP.1-88 Pass-by Data: Event 19L, 9/25/95 . . . . .	C-6
C16. AP.1-88 Pass-by Data: Event 1L, 9/27/95 . . . . .	C-6
C17. AP.1-88 Pass-by Data: Event 2R, 9/27/95 . . . . .	C-6
C18. AP.1-88 Pass-by Data: Event 3L, 9/27/95 . . . . .	C-7
C19. AP.1-88 Pass-by Data: Event 6L, 9/27/95 . . . . .	C-7
C20. AP.1-88 Pass-by Data: Event 7R, 9/27/95 . . . . .	C-7

**LIST OF TABLES (continued)**

TABLE

PAGE

C21.	AP.1-88	Pass-by Data: Event 9R, 9/27/95	. . . . .	C-7
C22.	AP.1-88	Pass-by Data: Event 10L, 9/27/95	. . . . .	C-8
C23.	AP.1-88	Pass-by Data: Event 11R, 9/27/95	. . . . .	C-8
C24.	AP.1-88	Pass-by Data: Event 12L, 9/27/95	. . . . .	C-8
C25.	AP.1-88	Pass-by Data: Event 15R, 9/27/95	. . . . .	C-8
C26.	AP.1-88	Pass-by Data: Event 16L, 9/27/95	. . . . .	C-9
C27.	AP.1-88	Pass-by Data: Event 17R, 9/27/95	. . . . .	C-9
C28.	AP.1-88	Pass-by Data: Event 19R, 9/27/95	. . . . .	C-9
C29.	AP.1-88	Pass-by Data: Event 20L, 9/27/95	. . . . .	C-9
C30.	LACV-30	Pass-by Data: Event 1R, 9/27/95	. . . . .	C-10
C31.	LACV-30	Pass-by Data: Event 2L, 9/27/95	. . . . .	C-10
C32.	LACV-30	Pass-by Data: Event 3R, 9/27/95	. . . . .	C-10
C33.	LACV-30	Pass-by Data: Event 4L, 9/27/95	. . . . .	C-10
C34.	LACV-30	Pass-by Data: Event 5R, 9/27/95	. . . . .	C-11
C35.	LACV-30	Pass-by Data: Event 6L, 9/27/95	. . . . .	C-11
C36.	LACV-30	Pass-by Data: Event 7R, 9/27/95	. . . . .	C-11
C37.	LACV-30	Pass-by Data: Event 8L, 9/27/95	. . . . .	C-11
D1.	Corrected One-Third Octave-Band (Un-weighted)Pass-by Spectral Data at 305 m (1000 ft)			D-2



## TERMINOLOGY

The following terms are highlighted in the main body of the document using boldface type:

### General Acoustics

**Acoustic Energy.** The integral of squared, instantaneous frequency-weighted sound pressure over a time interval. Acoustic energy is arithmetically equivalent to  $10^{\text{NoiseLevel}/10}$ , where the noise level is expressed in units of decibels (dB).

**Acoustically Hard Surface.** Any highly reflective surface in which the phase of the sound energy is essentially preserved upon reflection; examples include water, asphalt and concrete.

**Acoustically Soft Surface.** Any highly absorptive surface in which the phase of the sound energy is changed upon reflection; examples include terrain covered with dense vegetation or freshly fallen snow.

**A-Weighting Adjustment.** A frequency-dependent adjustment which de-emphasizes the high (6.3 kHz and above) and low (below 1 kHz) frequencies, and emphasizes the frequencies between 1 kHz and 6.3 kHz, in an effort to simulate the relative response of the human ear.

**Decibel (dB).** A unit of level which denotes the ratio between two quantities that are proportional to power; the number of decibels is ten-times the base-10 logarithm of this ratio. For the purpose of this document, the reference level is 20 :Pa, or the threshold of human hearing.

**Grazing Incidence.** Also referred to as 90-degree incidence, grazing incidence occurs when sound waves impinge at an angle that is parallel

to, or grazing, the plane of the microphone diaphragm (see Figure below). This orientation is preferred for moving, or line-source measurements, since the microphone presents constant incidence angle to any source located within the plane of the microphone diaphragm.

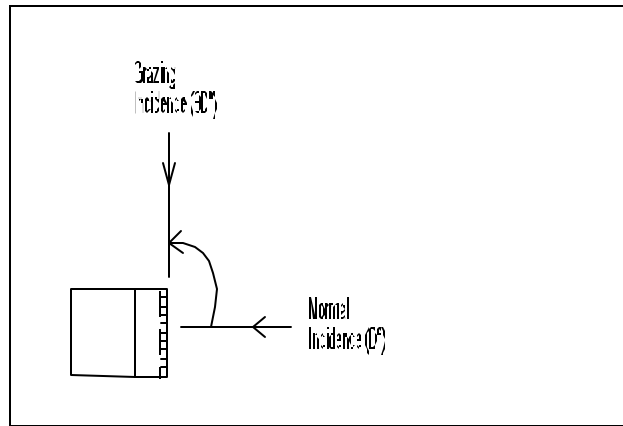

**Figure i: Grazing Incidence**

**Masked Data.** by noise in environment noise) or the ( p o s t -

Test data obscured either the ambient (pre-detection measurement system detection noise).

**Sound Absorption.** Dissipation or conversion of sound energy into other forms of energy. For the purposes of this document, sound absorption by the atmosphere and the absorption of sound by various surfaces is commonly discussed.

**Standard-Day Atmospheric Conditions.** The atmospheric conditions corresponding to 15°C (59°F) and 70 percent relative humidity, commonly referred to as the International Standard Atmosphere (ISA). For the purposes of this document, standard-day atmospheric conditions are also referred to as reference-day atmospheric conditions.

**Noise Descriptors**

**Day-Night Average Sound Level (DNL, denoted by the symbol  $L_{dn}$ )**.  $L_{dn}$  is a 24-hour, time-averaged  $L_{AE}$  (see definition below), adjusted for average-day sound source operations. The adjustment includes a 10 dB penalty for operations, denoted by the symbol  $N$ , occurring between 2200 and 0700 hours local time.  $L_{dn}$  is computed as follows:

$$L_{dn} = L_{AE} + 10 \times \log_{10}(N_{day} + N_{eve} + 10 \times N_{NIGHT}) - 49.4 \quad (\text{dB}),$$

where  $L_{AE}$  = Sound Exposure in dBA (see definition below);

$N_{DAY}$  = number of operations between 0700 and 1900 hours, local time;

$N_{NIGHT}$  = number of operations between 2200 and 0700 hours, local time;

and 49.4 = a normalization constant which spreads the **acoustic energy** associated with hovercraft operations over a twenty-four hour period, i.e.,  $10 \times \log_{10}(86,400 \text{ seconds per day}) = 49.4 \text{ dB}$ .

**Maximum A-Weighted Sound Level with Slow-Scale Response Characteristics (MXSA, denoted by the symbol  $L_{ASMX}$ )**. The maximum A-Weighted sound level associated with a given event (see Figure, next page). Slow-scale response characteristics effectively dampen a signal as if it were to pass through a low-pass filter with a time constant of 1000 milliseconds.

**Sound Exposure Level (SEL, denoted by the symbol  $L_{AE}$ )**.  $L_{AE}$  is equal to ten times the logarithm to the base ten of the ratio of a given time interval of mean-squared, instantaneous A-weighted sound pressure, to the squared reference sound pressure of 20 Pa. The time integral must be long enough to include a majority of the sound source's acoustic energy. As a minimum, this interval should encompass the 10-dB down points. For the purposes of this document,  $L_{AE}$  was computed using data

encompassed by the 15-dB down points (see Figure below).

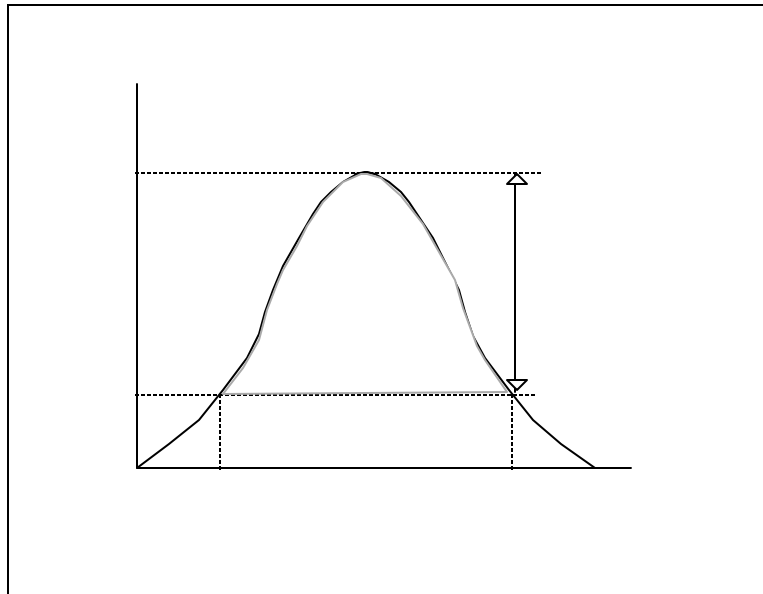

**Figure ii: Graphical Representation of  $L_{AE}$  and  $L_{ASmx}$  Noise Descriptors**

#### **Corrections to Acoustic Data**

The following correction factors, positive or negative, are added to the as-measured  $L_{ASmx}$  and  $L_{AE}$ , as appropriate, to obtain their corrected values (see Section 4).

**Atmospheric Absorption Correction.** A frequency-dependent correction factor (expressed in dB) which accounts for the difference in atmospheric absorption associated with the test-day atmospheric conditions and standard-day atmospheric conditions. It is computed in accordance with the Society of Automotive Engineers' (SAE) Aerospace Research Report (ARP) 866A<sup>1</sup>.

**Distance-Duration Correction.** A correction factor (expressed in dB) which accounts for the difference in event duration associated with the test distance (from source, in this case the hovercraft, to receiver), and the reference distance. It is independent of frequency, and is

computed as follows:  $10 \times \log_{10}(d_{\text{ref}}/d_{\text{test}})$ .

**Divergence Correction.** A correction factor (expressed in dB) which accounts for the difference in spherical divergence of the sound energy associated with the test distance, and the reference distance. It is independent of frequency, and is computed as follows:  $20 \times \log_{10}(d_{\text{test}}/d_{\text{ref}})$ .

**Reference Speed Correction.** A correction factor (expressed in dB) which accounts for the difference in test speed and a reference speed of 20 kts. It is independent of frequency, and is computed as follows:  $10 \times \log_{10}(V_{\text{test}}/20)$ .





## 1. INTRODUCTION

During the period, June 1995 through March 1996, the U.S. Department of Transportation, Research and Special Programs Administration, John A. Volpe National Transportation Systems Center (Volpe Center), Acoustics Facility, in support of the United States Postal Service (Postal Service) Office of Environmental Policy & Management, conducted a Noise Characterization Study of the British Hovercraft Corporation Model AP.1-88 Hovercraft (AP.1-88). This document presents the results of the study, including the measurement, data reduction and analysis procedures used to characterize the craft. Also presented, for the purpose of comparison with the AP.1-88 noise data, is a limited amount of measured noise data for the Textron Marine and Land Systems Lighter Air Cushion Vehicle-30 (LACV-30) hovercraft.

Section 1 presents an overview of the study. Section 2 describes the instrumentation employed in the study. Section 3 describes the methodology and procedures utilized in the study. Section 4 presents the data reduction and analysis procedures. Section 5 summarizes the data and related results of the study. Conclusions are drawn in Section 6.

### 1.1 BACKGROUND

The Postal Service is in the process of investigating the feasibility of utilizing hovercraft to transport mail to remote villages in the vicinity of Bethel, AK. As part of this investigation, the Volpe Center is conducting an Environmental Assessment (EA) of the proposed action. Initially, it was intended to use a LACV-30 for transport service. However, significant environmental concerns were raised with regard to this craft, in particular, the possible adverse effect the craft's operation would have on the noise environment in the surrounding villages. Previous studies (Schomer<sup>2</sup> and Dvornak<sup>3</sup>) have shown the LACV-30 to be comparable in noise level to first-generation commercial

jet aircraft and current military aircraft. Consequently, the Postal Service decided that, if this initiative were to be undertaken, the LACV-30 could not be used, and the AP.1-88 would be examined as a potential surrogate craft.

Unlike for the LACV-30, very few noise data were available for the AP.1-88 hovercraft.<sup>4</sup> Based on the small amount of available information, it was expected that the AP.1-88 would be a quieter craft than the LACV-30, but just how much quieter was not known. As a result, the Postal Service requested that the Volpe Center Acoustics Facility conduct a comprehensive noise characterization study of the AP.1-88.

## **1.2 OBJECTIVE**

The objective of the study was to collect sufficient data to characterize the noise of the AP.1-88 hovercraft for typical operating procedures, should it be used in the vicinity of Bethel, AK. It was intended that these data be used to: (1) develop the noise section of the EA which is being prepared for the Postal Service by the Volpe Center, as discussed in Section 1.1; and (2) compare the noise levels of the AP.1-88 to those of the LACV-30, as well as those of other, more common transportation vehicles, e.g., aircraft and surface transportation vehicles.

### 1.3 TEST HOVERCRAFT

Noise measurements were performed on both an AP.1-88 (Manufacturer Craft Number 8901) and a LACV-30 (Manufacturer Craft Number 04). The AP.1-88 was configured as it would be for the proposed mail transport service in the vicinity of Bethel, AK. However, several modifications to the tested LACV-30 would be required before it could be used for commercial service.

The AP.1-88 is approximately 12 m (40 ft) wide by 21 m (70 ft) long, weighs about 25,424 kg (56,000 lbs) empty, can carry up to 8,264 kg (16,000 lbs) of cargo and 24 passengers, utilizes a total of four diesel marine engines; two for lift: Deutz 390 hp, Model BF10L413FC; and two for propulsion: Deutz 500 hp, Model BF12L413FC. It can cruise at speeds of up to 81 km/h (50 mph) (see Figure 1).

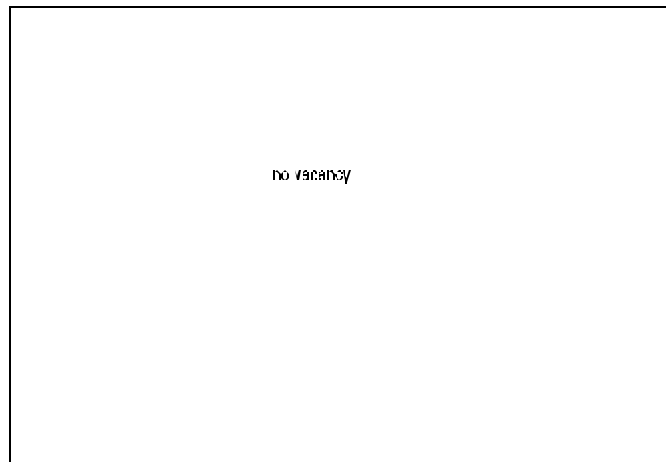

**Figure 1: The AP.1-88 Hovercraft**

The LACV-30 is approximately 12 m (40 ft) wide by 24 m (80 ft) long, weighs about 29,510 kg (65,000 lbs) empty, can carry up to 27,240 kg (60,000 lbs) of cargo, utilizes gas turbines to power its twin-propellers, and can cruise at speeds of up to about 97 km/h (60 mph). Its cargo deck is slightly larger than 150 m<sup>2</sup> (1,600 ft<sup>2</sup>), and would require modification to facilitate passengers (see Figure 2).

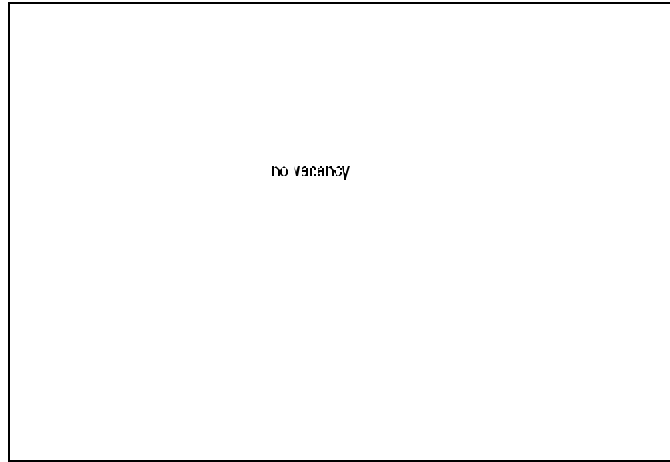

**Figure 2: The LACV-30 Hovercraft**

For the purposes of the current study, both the AP.1-88 and the LACV-30 were loaded with approximately 4500 kg (5 tons) of cargo. It was agreed upon by the Postal Service, Alaska Hovercraft Ventures JV (Alaska Hovercraft) and the Volpe Center that 4500 kg of cargo was a maximum load for projected mail transport service on any given day in the vicinity of Bethel, AK. The cargo, implemented as five bundles of salt on the LACV-30 and two full water tanks on the AP.1-88, was securely fastened in the appropriate area of each craft.

Based on the authors' experience with aircraft noise studies, it is expected that the noise level associated with each craft will, to a certain degree, depend upon operating weight. Typically, for aircraft, noise levels increase with increasing operating weight. Therefore, the noise level data presented herein may not be appropriate for cargo loads which differ significantly from 4500 kg.

#### **1.4 TEST SITE**

The noise measurement test site was located on the northeast tip of Fire Island, which is located in Cook Inlet, approximately 14 km (9 mi) west southwest of downtown Anchorage, AK (see Figure 3). Figure 4 shows the relative location of Anchorage to Bethel, the base village

for proposed hovercraft mail transport service.

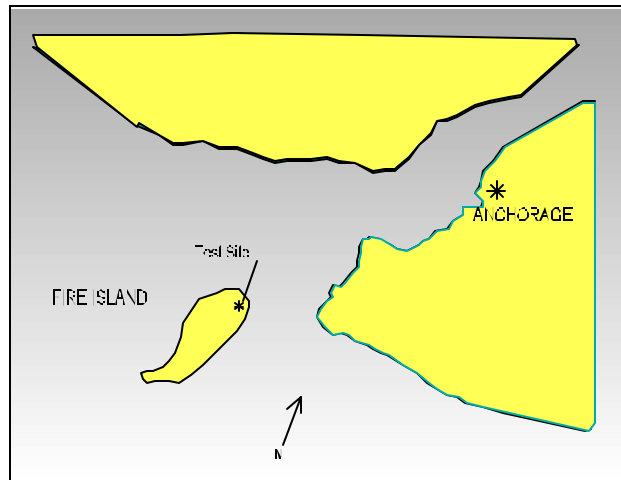

Figure 3: Noise Measurement Test Set-up (not to scale)

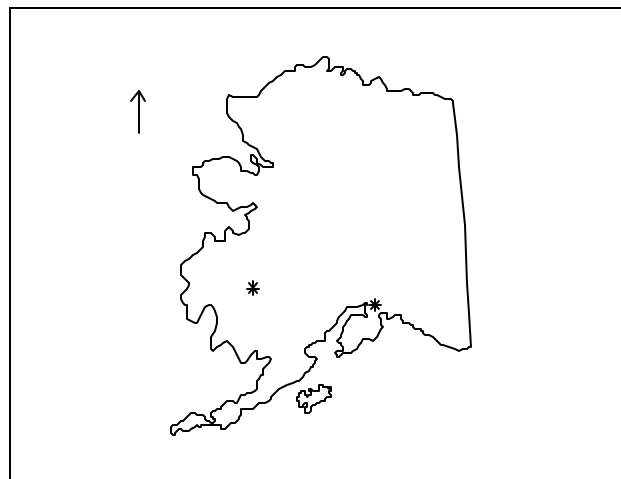

Figure 4: Relative Location of Bethel and Anchorage (not to scale)



## 2. MEASUREMENT INSTRUMENTATION

This section describes the instrumentation, acoustic and otherwise, employed in the study.

### 2.1 ACOUSTIC INSTRUMENTATION

A block diagram of the acoustic instrumentation is shown in Figure 5.

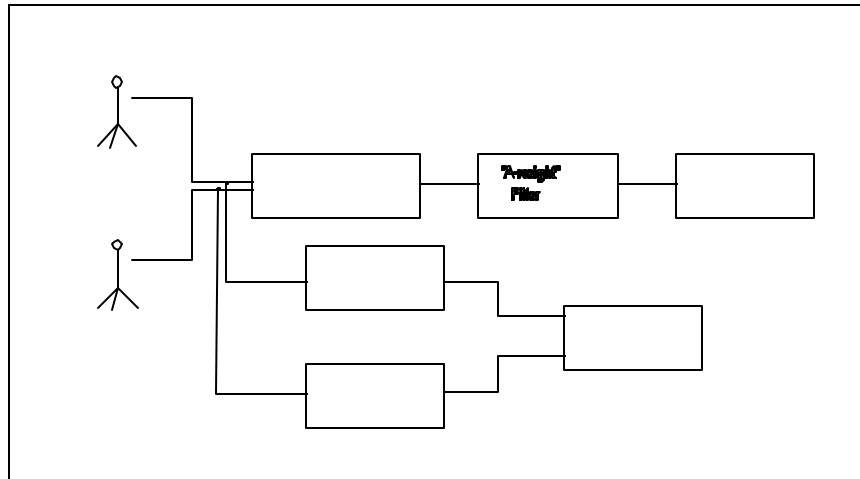

Figure 5: Acoustic Instrumentation

The noise data acquisition system consisted of two Brüel and Kjør (B&K) Model 4155 one-half inch, free-field, electret-condenser microphones (Microphone 1 and Microphone 2, as shown in Figure 5), each connected to a General Radio Model 1560-P42 preamplifier. The microphone/preamplifier combinations were mounted in insulated nylon holders and fastened to tripods. The diaphragms of the microphones were positioned for **grazing incidence**, relative to the test path of the hovercraft at a height of 1.2 m (four ft) above ground level. In addition, a clean B&K Model UA0237 windscreen was placed atop each microphone to reduce the effect of wind-generated noise. Microphone 1 was placed closest to the shore-line, and in most cases Microphone 2 was positioned 31 m (100 ft) directly behind Microphone 1, on a line perpendicular to the hovercraft pass-by path. For the **C**-nmi pass-by measurements, Microphone 2 was placed 61 m (200 ft) directly behind



Microphone 1. Microphone 2 was used strictly to characterize the noise level drop-off rate, as a function of distance, at the test site.

Each microphone/preamplifier system was connected directly, via 91 m (300 ft) cables, to individual channels of a Larson Davis Model 2900 dynamic, real-time, one-third octave-band Spectrum Analyzer (LD2900). The LD2900 was programmed to measure and internally store the **maximum A-weighted sound level with slow-response time-weighting characteristics (MXSA, denoted by the symbol  $L_{ASmx}$ )**<sup>\*</sup>, the A-weighted, one-third octave-band spectrum associated with  $L_{ASmx}$ , the **sound exposure level (SEL, denoted by the symbol  $L_{AE}$ )** and the A-weighted, spectral time-history in ½-second increments. The data in the internal memory of the LD2900 were periodically transferred to a floppy disk.

The LD2900 allowed the measurement crew access to immediate on-line noise data, for both relative comparison of individual events and comparison with existing data in the literature (see References 2 through 4). The on-line data were stored in a manner which allowed for later, off-line processing and analysis, if needed.

The analog signal from each microphone/preamplifier system was also fed through an amplification stage to a Sony Model TCD D10 ProII Digital Audio Tape Recorder (DAT). The recorded data were used for off-line reduction and analysis, as discussed in Section 4. A headphone set connected to the DAT Recorder provided real-time audible monitoring of data integrity. The signal from Microphone 1 was also **A-weighted** and connected to a B&K Model 2317 Graphic Level Recorder (GLR).

The GLR was set to produce a graphic time-history recording (**A-weighted** noise level versus time) at a paper transport speed of 1 mm/s (0.0394

---

\* As previously noted, all terms defined in the Terminology section are highlighted when they appear in the main body of the text of this document.

in/s). This recording aided in on-site verification of the acoustic integrity of each event. Each event was labeled on the recording to ease off-line event correlation of GLR and DAT-stored data with the field-data log sheets.

B&K Model 4231 sound-level calibrators, which produce a signal of 1000 Hz at a sound-pressure level of 114 **decibels (dB)** re 20 : Pa, were used to calibrate each channel of the measurement system. Passive microphone simulators (dummy microphones) were used to establish the electronic noise floor of the noise measurement system. Cetec Ivie Model IE-20B random-noise generators were used to determine the frequency response of the noise measurement system.

## **2.2 SUPPORT INSTRUMENTATION**

### 2.2.1 Meteorological Instrumentation

Meteorological conditions, including temperature, relative humidity and wind speed, were recorded prior to data collection, at 15-minute intervals thereafter, and during any noticeable weather changes, using a sling psychrometer and wind cup anemometer. The wind speed data were measured to insure that noise data were not collected when wind speeds exceeded 19 km/h (12 mph). Temperature and humidity data were measured for the purpose of performing off-line data analysis and correction.

### 2.2.2 Communication Instrumentation

Motorola Radius, Model GP300 portable radios were used for communication between the test hovercraft and measurement-site crew located on Fire Island. The measurement-site crew and the hovercraft crew had both a primary, and a backup radio. As a further backup, a hand-held radio, compatible with the hovercraft's on-board radio was also available at the measurement site.

### 2.2.3 Hovercraft Guidance/Tracking Instrumentation

For the AP.1-88 tests, the on-board Echotec Model CTM951 Global Positioning System (GPS) receiver was used to both maneuver and track the craft. In chart mode, the GPS receiver allowed the simultaneous viewing of both the measurement site and the "real-time" position of the hovercraft. A Raytheon Model 4804C color radar system with variable range meter (VRM) was used to augment and backup the GPS system.

For the LACV-30 tests, the on-board Raytheon Mariners Pathfinder Model 1210 was used to both maneuver and track the craft. This system was quite old, fairly difficult to use and had no backup. Consequently, for the LACV-30 pass-by tests, two fluorescent orange buoys were anchored at a fixed distance of **C** nmi to aid the hovercraft crew in following the reference path. The buoys helped to insure that the LACV-30 followed the straightest possible path.

### 3. EXPERIMENTAL APPROACH

This section describes the procedures and methodology used during the field measurements.

#### 3.1 TEST SITE

The noise measurement test site was located on the northeast tip of Fire Island, between an abandoned Airstrip and North Point. This location was desirable because of its relative shelter from the wind, reduced susceptibility to ocean-related noise disturbances and generally flat topography.

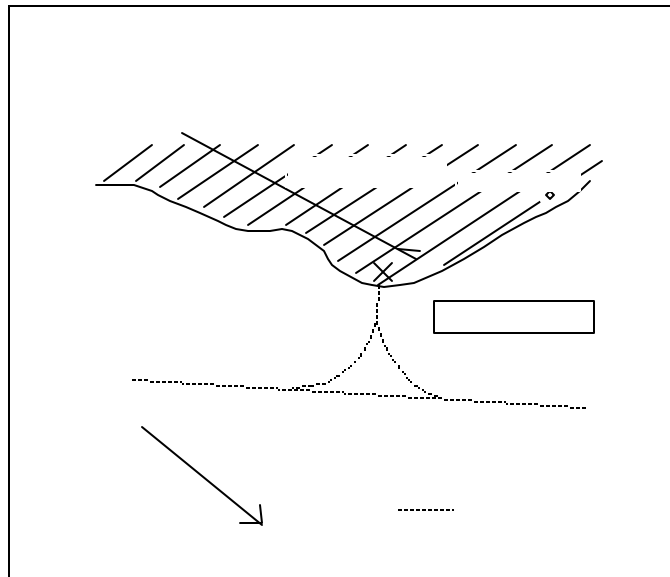
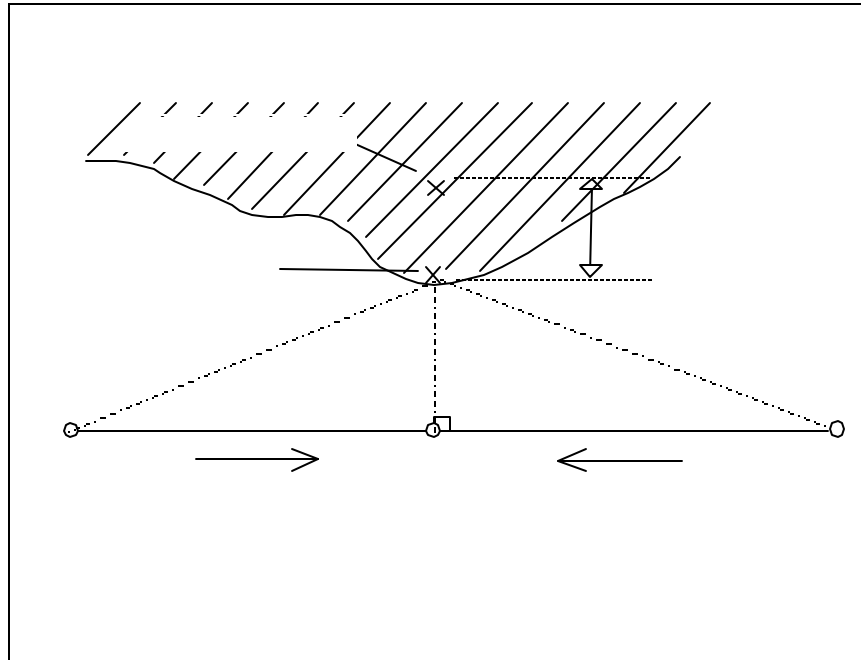

Figure 6: Test Site (not to scale)

As seen in Figure 6, except for the final/initial segment of the approach/departure measurements, respectively, the hovercraft test paths were entirely over water. Measurements were made over water, an "acoustically hard" surface, so that ground-surface effects which tend to be complicated and often difficult to quantify, could be neglected. In addition, one requirement of the Postal Service contract with Alaska Hovercraft is that the hovercraft routes be limited to waterways in the vicinity of Bethel, AK. Consequently, over-water operations are considered typical for the proposed mail transport service.

### 3.2 MICROPHONE LOCATIONS

Two microphones were deployed as shown in Figures 7 and 8 for pass-by and approach/departure operations, respectively.



**Figure 7: Pass-by Test Set-up** (not to scale)

The goal during measurements was to place Microphone 1 as close as possible to the shore-line. The extreme tidal changes made it necessary to move the microphone positions at times, creating known, yet varied, distances to the shore-line. This distance variation was accounted for in the data reduction and analysis.

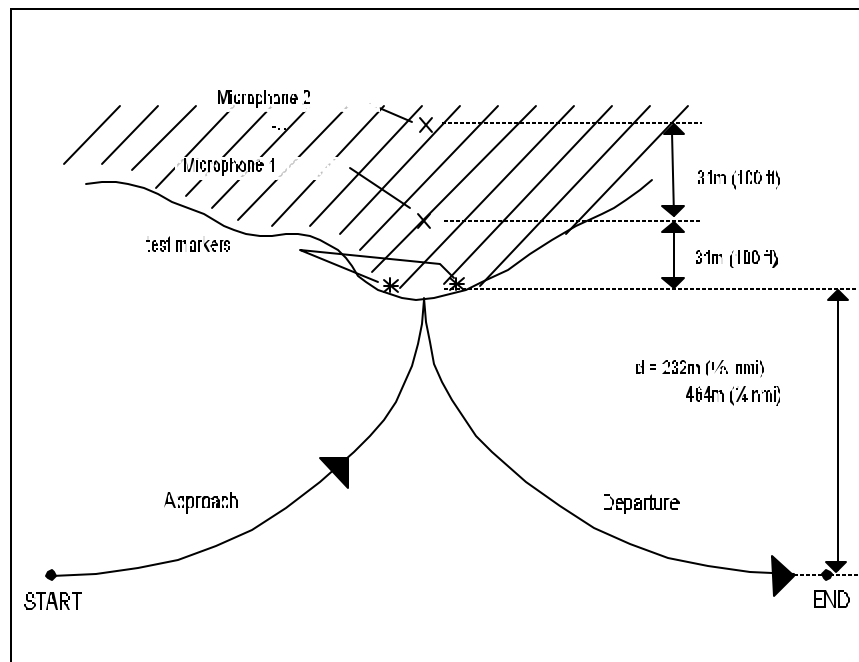

**Figure 8: Approach/Departure Test Set-up** (not to scale)

### 3.3 TEST PROCEDURES

In general, test procedures were consistent with the Volpe Center's field-measurement Test Plan.<sup>5</sup> Specifically, radio communication was used to coordinate event information. Typically, the measurement-site crew notified the hovercraft crew that they were ready for an event. After the craft was stabilized in terms of position, speed and power settings, as per the appropriate test procedure, the hovercraft crew would then signal the beginning of the event. The start of data collection was determined by the measurement-site operator's estimate of the 15 to 20 dB down points of the **A-weighted** time history, available on-line from the GLR. Radio silence was then observed from the moment the hovercraft crew signaled the beginning of the event until the measurement crew signaled the end of the event. Radio silence was disturbed only when it was necessary to declare an event "no good". An event was declared "no good" if it was determined that sound from sources other than the test hovercraft, e.g., aircraft, birds, surf, etc., contaminated the data. Due to the relatively close proximity of the measurement site to Anchorage International Airport, a few events had to be repeated due to aircraft intrusion.

Pass-by measurements were conducted with the hovercraft operating at "typical", constant-speed, cruise conditions. Typical conditions were mutually agreed to by the Postal Service, Alaska Hovercraft and the Volpe Center, taking into account proposed operating procedures in the vicinity of Bethel, AK. A reference cruise speed of 20 kts was chosen for all pass-by measurements. The 20 kts reference speed was based on speeds presented in the Alaska Hovercraft document: " *Proposed Village Mail Delivery Schedule*", a copy of which is presented in Appendix A. The goal was to capture 6 events in each direction, i.e., left-to-right and right-to-left, as viewed from the test site, at both the **C**- and ¼-nmi distances for only the AP.1-88, and 6 in each direction at the **C**-nmi distance only for the LACV-30. The purpose of measuring pass-by events with the craft proceeding in both directions was to eliminate any directivity effects in the final, averaged results. As stated earlier, the LACV-30 data will be used to corroborate previously measured data, as well as allow for comparison of noise level data for the AP.1-88 and LACV-30 hovercraft.

Approach/departure measurements were conducted with the AP.1-88 operating under "typical" acceleration and deceleration patterns. Typical conditions were based on expected operating procedures to be observed in the vicinity of Bethel, AK. These included both approach-to-idle and approach-to-shutdown procedures, as well as their corresponding departures. The goal was to capture 6 approaches and 6 departures, with the hovercraft beginning and ending its respective procedure from a distance of **C**- and ¼-nmi from the shore-line. As was the case with the pass-by events, the purpose of measuring approach/departure events with the craft proceeding in both directions was to eliminate any directivity effects in the final, averaged results.

The entire measurement system was calibrated at the beginning and end of each measurement day, as well as at hourly intervals throughout the day. In addition, the electronic noise floor and frequency response of

the system were checked at the beginning of each measurement day.





## 4. DATA REDUCTION AND ANALYSIS

This section describes the procedures used to obtain the acoustic data sets for the pass-by operations, as presented in Appendices B, C, and D. Detailed data reduction procedures were not necessary for the approach/departure data (see Section 5.2). The Volpe Center employed data reduction, processing, and analysis procedures which conform to established aircraft and highway noise methodologies.<sup>6,7</sup> The elements of these procedures are presented in detail below.

### 4.1 ON-LINE NOISE DATA

Initial on-site noise level data were obtained from the LD2900, which was programmed to store the following data for each event: (1) the  $L_{ASmx}$ ; (2) the **A-weighted** one-third octave spectrum at time of  $L_{ASmx}$ ; and (3) the  $L_{AE}$ . These data were used for preliminary on-site comparisons and as a backup to the digitally-recorded data. On-line noise level data for the AP.1-88 pass-by operations are presented in Appendix B, Table B1.

### 4.2 METEOROLOGICAL DATA

As described in Section 2.2.1, meteorological data were collected periodically throughout each measurement day. During processing, these data, using linear interpolation over time, were used to obtain the temperature and humidity associated with the  $L_{ASmx}$  of each event. The temperature and humidity associated with each event were utilized for extrapolation of **masked** high-frequency **data** (see Section 4.4.1) in the as-measured case, and to eliminate any test-day atmospheric effects in the process of correcting the as-measured data to **standard-day atmospheric conditions**. The temperature and humidity data associated with each event are presented in Appendix B, Tables B1 and B2.

### 4.3 TRACKING DATA

Tracking data, including speed and distance between the microphone and hovercraft at closest-point-of-approach (CPA), were used in conjunction with test-day **absorption** coefficients for correction of the as-measured data to **standard-day atmospheric conditions**. The speed and distance data measured for each event are included in Appendix B, Tables B1 and B2.

### 4.4 DIGITALLY-RECORDED NOISE DATA

The DAT tapes were analyzed at the Volpe Center's Acoustics Facility in Cambridge, Massachusetts. Figure 9 is a block diagram of the acoustic data analysis instrumentation.

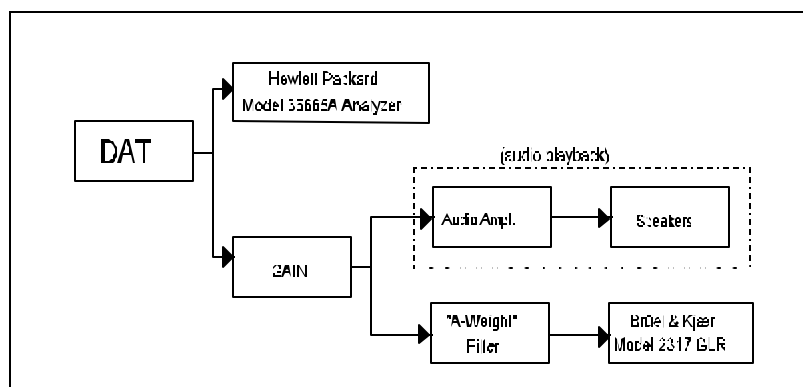

**Figure 9: Acoustic Data Analysis Instrumentation**

The recorded data were reproduced and fed into a Hewlett Packard, Model 35665A, Real-time Dynamic Signal Analyzer (HP35665A). The start time and duration of each event were determined by first listening to the recorded data and observing the GLR output. Care was taken to insure that no extraneous sounds contaminated the data to be analyzed. Contiguous ½-second records of one-third octave-band Sound Pressure Levels (SPLs) (25 Hz to 10 kHz) were linearly averaged, digitized and stored by the analyzer in computer files over the operator-specified duration for each event.

Also processed and stored in separate files were ½-second records of recorded calibration signals, pink noise signals and ambient data. System gain and calibration adjustments were applied to all recorded data. Time-of-day was assigned to the midpoint of each ½-second data record based upon the start time at the onset of the event and the index number assigned to each data record.

The propagation distances and relative position of the hovercraft at the time of noise emission of each ½-second data record were computed assuming a straight-line test path, perpendicular to the line defined by the microphones, given both the craft's speed and distance at CPA.

#### 4.4.1 Background Noise

The lowest SPLs measurable during any given event are limited by the background noise levels present during the event. Per the methodology of the Federal Aviation Administration (FAA), background noise is considered to be comprised of pre-detection and post-detection noise. By definition, pre-detection noise includes the ambient noise levels at the test site, as well as electrical noise present in the measurement system. The concept of post-detection noise is used to address the issue of instrumentation dynamic range, and represents the minimum valid SPLs measurable, using a specific measurement/analysis system. For this study, the post-detection noise levels were identified as the amplitude linearity limits for either the HP35665A, or the DAT recorder, whichever was greatest for each recording and analysis gain configuration. As a result of tests performed by the Volpe Center, the amplitude linearity limits for the HP35665A and the DAT recorder were determined to be 80 dB and 95 dB below full-scale, respectively. If not properly accounted for, background noise can add, on an energy basis, to the noise generated by the vehicle being tested, and as such results in contaminated data.

Representative ambient data values were obtained by analyzing a 10-

second, time-averaged sample of data recorded prior to each measurement event, absent of noise from the test hovercraft. These pre-detection levels were compared to the post-detection noise levels in order to eliminate any values which might be below the minimum valid levels. Adjustments for the remaining one-third octave-band, pre-detection noise levels were then applied to event data in the background-noise correction-procedure, as described below.

One-third octave-band SPLs for each event were first tested against the post-detection noise levels. Any one-third octave-band SPL that did not exceed the post-detection noise level by at least 1 dB was identified as being **masked**. Non-**masked** one-third octave-band SPLs were then tested against the pre-detection noise levels. Any SPL below the pre-detection level plus 3 dB was also identified as being masked. (Note: These masking criteria are consistent with FAA methodology.) Non-masked SPLs were corrected for the presence of background noise by performing an energy-subtraction of the pre-detection noise from the event SPL. In cases where the level of a masked SPL occurred within the 3 dB window above the pre-detection noise level, the SPL was set equal to the level of the pre-detection noise. In cases where the level of a masked SPL was at or below the level of the pre-detection noise (or the post-detection noise plus 1 dB), the SPL was left unchanged. **Masked data** values were reconstructed at a later point in the processing, using spectral shaping procedures (see Section 4.4.3). Note that sensitivity tests performed during analysis indicate that the effects of background noise on this data set were negligible (i.e., typically less than 0.1 dB), confirming that the quality of the recorded data is quite good.

#### 4.4.2 Frequency Response Correction

One-third octave-band frequency-response corrections were obtained by energy-averaging a 30-second portion of the recorded pink noise signal from each tape. This set of corrections compensates for deviations in

the frequency response of the entire noise measurement, recording and analysis system, with the exception of the microphone and windscreen. One-third octave-band corrections for microphone frequency-response obtained from individual microphone calibration-data, were combined with microphone and windscreen incidence corrections, obtained from published manufacturer's data. All of these corrections were then applied to the unmasked portions of the ambient-adjusted, raw, spectral data.

#### 4.4.3 Spectral Shaping

Data records with masked high-frequency bands (as identified in Section 4.4.1) were further adjusted by reconstructing the levels for the masked bands via a frequency-extrapolation process consistent with FAA methodology. Utilizing one-third octave-band atmospheric absorption coefficients (for temperature and humidity at the time of  $L_{ASmx}$  for each event), a new value for each of the masked bands in a record was computed by calculating the difference in the atmospheric absorption coefficients of the masked and highest-frequency non-masked band. This difference was then applied over the actual distance between the source and receiver for each individual record (calculated using the craft's speed, distance at CPA, and the record time-of-day), and subtracted from the level of the highest-frequency non-masked band (Note: This methodology assumes that the source spectrum is flat in the region of the **masked data**.) Sensitivity tests performed during analysis indicate that the effect of such frequency-extrapolation is negligible for this data set, especially when noise descriptors based on **A-weighting** (which minimizes the contribution of the high-frequency one-third octave-band SPLs) are used.

#### 4.4.4 Simulation of "Slow-Scale" Exponential Time Constant

The ½-second linear data were further processed to simulate the effect

of slow-scale time-averaging as typically employed in traditional sound level meters, and commonly used for analyzing aircraft noise. This was accomplished using the following algorithm for a continuous exponential function:

$$\text{SPL}_{i,\text{SLOW}} = 10 \times \log_{10} \{ [0.4 \times 10^{(\text{SPL}_{i,\text{LIN}} \times 0.1)}] + [0.6 \times 10^{(\text{SPL}_{(i-1),\text{SLOW}} \times 0.1)}] \}$$

where: I represents a ½-second data record; and the subscripts "LIN" and "SLOW" represent the adjusted linear data set and the resultant slow-scale data set, respectively.

This calculation is performed separately for each one-third octave-band from 25 Hz to 10 kHz. It can be seen that each ½-second record in the slow-scale data set is comprised of an energy-percentage of the corresponding linear data record combined with an energy-percentage of the previously-calculated, slow-scale record, thus forming a continuous exponential time-averaging function which accurately simulates the 1000 millisecond time-constant employed in slow-scale metering systems.

The exponentially-averaged and adjusted data set (consecutive records of 27 one-third octave-band SPLs, 25 Hz to 10 kHz), resulting from the processing to this point, will be referred to herein as the "as-measured" pass-by data set.

#### 4.4.5 As-Measured Noise Descriptor Computations

The as-measured, pass-by data set was further processed to yield event noise descriptors. The  $L_{\text{AE}}$  family of descriptors was computed using 27 one-third octave-bands of data (25 Hz to 10 kHz) and includes:

**$L_{\text{AE}}$  - Sound Exposure Level (abbreviated SEL)**, computed over the 15dB-down duration of each event.

**$L_{ASmx}$  - Maximum A-weighted Noise Level (abbreviated MXSA).**

The as-measured descriptors for the pass-by operations are tabulated in Appendix B, Table B2.

**4.5 CORRECTIONS TO REFERENCE CONDITIONS - SIMPLIFIED PROCEDURE**

In order to allow for meaningful comparison with noise data of other transportation vehicles, and to facilitate the assessment of noise impact on the environment, processing was performed to obtain a "corrected" pass-by data set, representing the noise that would be generated during standardized operations and **standard-day atmospheric conditions**. The methodology of FAA's "simplified" correction procedure was implemented. The focus of this procedure is to perform **atmospheric absorption corrections** on the data spectrum measured at the time of  $L_{ASmx}$ . Divergence, **speed**, and **distance-duration correction** factors are then computed, and corrected noise levels are derived.

4.5.1 Simplified Correction Procedure (refer to Figure 10)

Given:

- As-measured  $L_{ASmx}$  and  $L_{AE}$ ;
- As-measured one-third octave-band spectrum obtained at the time of  $L_{ASmx}$ ;
- Temperature and humidity at the time of  $L_{ASmx}$ ;
- Test craft speed (V) and test distance (d) at CPA (Assumed to coincide with distance at the time of  $L_{ASmx}$ );
- Reference temperature (15°C, 59°F) and relative humidity (70 % RH); and
- Reference speed ( $V_{ref}=20$  kts) and reference distance ( $d_{ref} = 50, 100, 200, 500, 1000, 2000, 5000$  and  $10000$  m,



respectively).

Note: Test conditions coincide with actual, field-observed conditions, i.e., the test distance equals the actual distance between the microphone and the hovercraft during a given event.

Steps 1 through 3 describe the process required to obtain the corrected one-third octave-band  $L_{ASmx}$  spectrum associated with reference conditions.

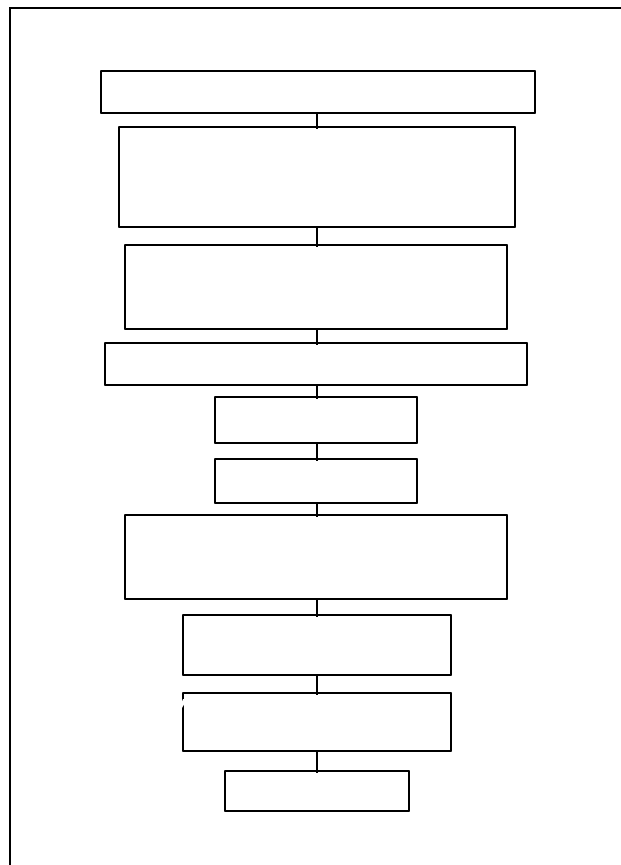

**Figure 10: Correction Process**

1. Calculate the test and reference atmospheric absorption coefficients,  $\alpha_{test}$  and  $\alpha_{ref}$ , per SAE ARP 866A (see Reference 1), for each one-third octave-band (25 Hz to 10 kHz). These coefficients represent sound attenuation through the atmosphere in units of dB per 1000 ft.

2. Adjust each one-third octave-band in the as-measured  $L_{ASmx}$  spectrum for the difference between the test and reference atmospheric absorption coefficients ( $\alpha_{test}$  and  $\alpha_{ref}$ ) over the test propagation distance, and for the difference between the test and reference propagation distances ( $d$  and  $d_{ref}$ ).
3. Adjust each one-third octave-band level obtained in Step 2 for divergence over the difference between test and reference propagation paths. The resultant one-third octave-band SPLs comprise the "corrected  $L_{ASmx}$  spectrum", which would have been received at the reference distance under **standard-day atmospheric conditions**. The SPLs in each one-third octave-band are then **A-weighted** and summed, on an energy basis, to obtain the corrected  $L_{ASmx}$  ( $L_{ASmx(cor)}$ ).

Steps 4 through 7 describe the process required to obtain the corrected  $L_{AE}$  associated with reference conditions.

4. Calculate  $\Delta_1$ , the difference between test and reference **A-weighted** sound levels associated with the  $L_{ASmx}$  spectrum:

$$\Delta_1 = L_{ASmx(cor)} - L_{ASmx}$$

5. Calculate  $\Delta_s$ , a speed correction for the difference between test and reference vehicle speeds ( $V$  and  $V_{ref}=20$  kts):

$$\Delta_s = 10 \log_{10}(V/V_{ref})$$

6. Calculate  $\Delta_D$ , a **distance-duration correction** which accounts for the effective change in event duration based on test and reference distances ( $d$  and  $d_{ref}$ ):

$$\Delta_D = 10 \log_{10}(d_{ref}/d)$$

7. Compute  $L_{AE(corr)}$ , by adding the corrections obtained in Steps 4 through 6 to the as-measured  $L_{AE}$ :

$$L_{AE(corr)} = L_{AE} + )_1 + )_S + )_D$$

This procedure was repeated for each of the eight reference distances used by Schomer (see Reference 2), so as to provide for easy comparison of the data sets. Corrected levels for the pass-by operations are presented in Appendix C.



## 5. DISCUSSION OF RESULTS

This section summarizes the results of the study. All related data can be found in Appendices B through D. Table 1 presents a summary of the total number of events measured for the pass-by and approach/departure tests of the AP.1-88, as well as the pass-by tests of the LACV-30.

**Table 1. Summary of Tests**

d (distance, nmi)	AP.1-88				LACV-30	
	Pass-by		Approach/Departure		Pass-by	
	Number	Direction	Number	Direction	Number	Direction
C (232m,760ft)	7	leftVright	5	Approach	4	left6right
C (232m,760ft)	7	rightVleft	5	Departure	4	right6left
¼ (464m,1520ft)	6	leftVright	6	Approach	-	-
¼ (464m,1520ft)	7	rightVleft	8	Departure	-	-
<b>TOTAL</b>	27		24		8	

### 5.1 PASS-BY DATA

A summary of average-corrected AP.1-88 pass-by data,  $L_{AE}$  and  $L_{ASMX}$  versus distance in meters, is presented in Table 2. For comparison purposes, similar data are presented for the LACV-30 in Table 3. The data presented in Table 3 include the LACV-30 data measured in the current study, as well as data presented in Schomer (see Reference 2).

The Schomer data were corrected in a similar manner to the Volpe Center data, except for the corrections for atmospheric absorption. Schomer used ANSI S1.26-1978<sup>8</sup>, whereas the Volpe Center used SAE ARP 866A (see Reference 1), as recommended by the FAA. Any related differences are expected to be quite small.

Volpe Center corrected data from a total of twenty-seven AP.1-88 and eight LACV-30 events were arithmetically averaged, separately for each craft to develop these Tables. Specifically, the data originally measured at **C**- and  $\frac{1}{4}$ -nmi distances (two distances for the AP.1-88 only) were used to develop separate noise versus distance tables for each event for each craft (see Appendix C). After developing these tables, it was determined that there was not a significant difference between data originally measured at **C**- and  $\frac{1}{4}$ -nmi distances. In addition, there was no significant difference between data measured for the left and right pass-bys of each craft. Therefore, it was deemed appropriate to average the data measured for a given craft, regardless of measured pass-by distance or side of the craft, in developing the final Tables.

The distance values represent the perpendicular distance between a receiver location and a hovercraft pass-by path which is long enough to include all significant contributions to the  $L_{AE}$  data. As discussed in Section 4, the  $L_{ASmx}$  data have been corrected for divergence and non-standard atmospheric conditions (i.e., conditions other than 15°C and 70% RH). Similarly, the  $L_{AE}$  data have been corrected for divergence, non-standard atmospheric absorption, distance-duration effects, and off-reference operating speed (i.e., speeds other than 20 kts).

**Table 2. Summary of AP.1-88 Pass-by Data**

Distance (m)	L <sub>ASmx</sub> (dB)	L <sub>AE</sub> (dB)
50	91.2	101.1
100	84.9	97.9
200	78.6	94.6
500	69.7	89.6
1000	62.4	85.3
2000	54.3	80.2
5000	41.7	71.6
10000	30.7	63.6

**Table 3. Summary of LACV-30 Pass-by Data**

Distance (m)	Volpe Center Data		Schomer Data <sup>1</sup>	Difference in L <sub>AE</sub> Data (Schomer minus Volpe)
	L <sub>ASmx</sub> (dB)	L <sub>AE</sub> (dB)	L <sub>AE</sub> (dB)	
50	111.7	119.9	122.9	3.0
100	105.5	115.5	118.8	3.3
200	99.2	113.4	114.9	1.5
500	90.3	108.5	110.0	1.5
1000	82.9	104.1	105.7	1.6
2000	74.7	98.9	100.4	1.5
5000	62.4	89.7	91.4	1.7
10000	49.2	80.3	83.5	3.2

As can be seen, the AP.1-88 is considerably quieter than the LACV-30, typically 17 to 21 dB, depending upon distance, and the particular noise descriptor chosen for comparison. This difference is in line with the previously presented as-measured AP.1-88 on-line data<sup>9</sup>, and indicates that between 50 and 80 operations of the AP.1-88 are equivalent to one operation of the LACV-30 in terms of total sound energy, i.e., the L<sub>AE</sub> noise descriptor.

It should be noted that there is excellent agreement between the LACV-30 measurements made by Schomer and the Volpe Center's measurements, with Schomer's levels always being slightly higher. Differences ranged between 1.5 and 3.3 dB, depending upon distance. These small differences are likely related to variations in wind conditions and ground characteristics associated with the two measurement studies. Other factors may include craft variability due to maintenance considerations, differences in craft loads during testing, and general measurement repeatability factors.

## 5.2 APPROACH/DEPARTURE DATA

A total of 24 AP.1-88 approach and departure events were processed. They were not, however, reduced as per Section 4. It was found that the **acoustic energy** associated with the segment of the approach\departure operation within about 120 m (400 ft) of the shore-line dominated the overall  $L_{AE}$ , regardless of starting distance from the shore-line, and thus the as-measured data would be appropriate to characterize the approach/departure tests.

More specifically, correcting the data to standard atmospheric conditions over such a short distance would have negligible effect on the overall noise level. To prove this hypothesis, a sensitivity test was performed using data from a few typical approach/departure events. The results showed that the effective change in the level due to correction to standard atmospheric conditions was less than 0.1 dB.

Due to a lack of detailed tracking data for the craft, correction for divergence, distance-duration effects, and off-reference speed was impossible. However, since the as-measured data were dominated by noise emissions within approximately 120 m (400 ft) of the shore-line, these effects can be neglected. Further, any small deviations in the craft's test path relative to a reference approach/departure path would be random, and as such, statistically insignificant because of the



large number of measured events.

It was decided that the most meaningful way to present the approach/departure data was as a single, arithmetically averaged  $L_{AE}$  value, which includes the **acoustic energy** from both approach and departure, for a distance at CPA of 31 m (100 ft). Thus, average  $L_{AE}$  values were computed independently for the approach and departure tests. These two average values were then added together on an energy basis, to obtain a combined  $L_{AE}$  for a single approach/departure operation. The  $L_{AE}$  value for one operation, defined as one approach and one departure combined, is as follows:

Approach/Departure Average  $L_{AE}$  at 31 m (100 ft): 98.3 dB

In calculating the  $L_{AE}$  value for an approach/departure operation, two departures were omitted from the average. These departures included engine-start-up prior to departure (Events 2RD and 4RD), as opposed to engine-idle. This type of departure operation was performed in an attempt to simulate all possible scenarios of hovercraft operations in the vicinity of Bethel. However, it was determined that this type of operation would rarely occur. The average  $L_{AE}$  value for the engine-start-up departures was approximately 8 dB greater than the average  $L_{AE}$  value for all other approach/departure events.

### 5.3 SPECTRAL DATA

For comparative purposes, an average, un-weighted one-third octave-band spectrum is presented in Figure 11 for the pass-by events of both the AP.1-88 and LACV-30. The spectral data, taken from the DAT tapes, were measured at the time  $L_{ASmx}$  occurred. The data have been corrected for divergence and non-standard atmospheric conditions to a distance of 305 m (1000 ft).

The figure shows that the two craft have similar spectral shapes, but the LACV-30's sound level is as much as 20 dB greater than that of the AP.1-88 in several one-third octave-bands. Also presented, in Appendix D, are the corrected one-third octave-band spectral data for each pass-by event, which were used to develop the average spectra shown in Figure 11.

**Figure 11. Pass-by Spectral Level Versus Frequency**

### 5.4 ASSESSMENT OF COMMUNITY NOISE IMPACT DUE TO HOVERCRAFT

Tables 2 and 3 (Section 5.1) have been developed in a manner consistent

with data base development requirements associated with aircraft modeling programs, such as the FAA's Integrated Noise Model<sup>10</sup>, and the U.S. Air Force's NOISEMAP Model.<sup>11</sup> These data, coupled with more detailed hovercraft tracking and performance information, can be used with such models to perform an in-depth analysis of hovercraft noise impacts.

In addition, the pass-by noise data presented in these Tables, coupled with the average  $L_{AE}$  for an approach/departure operation, can be used for performing relatively simple, yet quite accurate assessments of noise impacts for operations similar to those proposed for mail transport service in the vicinity of Bethel, AK. Appendix E presents an example of this relatively empirical assessment methodology.



## 6. CONCLUSIONS

This study was successful in gathering sufficient data to accurately characterize the noise emitted by the British Hovercraft Corporation Model AP.1-88 Hovercraft. A noise database has been established which will allow for modeling of hovercraft noise impact.

It was confirmed that the AP.1-88 is significantly quieter than the LACV-30, on the order of 17 to 19 dB, in terms of total sound energy, i.e., based on the  $L_{AE}$  noise descriptor. Additional conclusions are as follows:

- The  $L_{AE}$  associated with the AP.1-88 is comparable to that of typical, general aviation-type aircraft. Specifically, differences in  $L_{AE}$  values at comparable distances for the AP.1-88, and two typical, dual-engine general aviation aircraft, the Beachcraft-58P and DeHaviland-C6, operating at an airspeed of 160 kts and typical takeoff thrust levels, range between 2 and 5 dB<sup>10</sup>, with the AP.1-88 levels being higher. Such small differences are barely perceptible to the human ear.
- For a distance of 15 m (50 ft), a passenger car pass-by at 96 km/h (60 mph), a medium truck pass-by at 64 km/h (40 mph) and a heavy truck pass-by at 32 km/h (20 mph), are each approximately equivalent to one AP.1-88 pass-by at a distance of **C** nmi (230 m, 755 ft)<sup>12</sup>, based on the  $L_{ASmx}$  noise descriptor.
- For a distance of 15 m (50 ft), a 48 km/h (30 mph) snowmobile pass-by<sup>13</sup> is approximately equivalent to an AP.1-88 pass-by at **C** nmi (230 m, 755 ft), based on the  $L_{ASmx}$  noise descriptor.
- In contrast, the  $L_{AE}$  associated with a LACV-30 pass-by is more in line with a full-power takeoff of an F-16 at comparable distances

and an airspeed of 160 kts.<sup>11</sup>

The above conclusions are expected to be somewhat dependent on the design and performance characteristics of the specific AP.1-88 tested. Consequently, Alaska Hovercraft provided written verification that the tested craft configuration was essentially identical to that which is proposed for use in the vicinity of Bethel, AK (see Appendix F).

**APPENDIX A.**

***PROPOSED MAIL DELIVERY SCHEDULE***

Appendix A presents the Proposed Mail Delivery Schedule, an excerpt from the Draft Operations Plan presented to the Postal Service by Alaska Hovercraft.





## APPENDIX B.

### AS-MEASURED DATA

Appendix B presents the as-measured data for all events processed. These data include test date and craft type, event number, temperature ( $^{\circ}\text{C}$ ), humidity (% RH),  $L_{ASmx}$  (dB) and  $L_{AE}$  (dB). Distance (nmi) and speed (kts) are also included for pass-by measurements.



**Table B-1. As-Measured LD2900 Pass-by Data**

Test Date / Craft	Event	Meteorological Data		As-Measured Data			
		Temperature (°C)	Humidity (% RH)	Distance (nmi)	Speed (kts)	L <sub>ASMX</sub> (dB)	L <sub>AEB</sub> (dB)
9/25/95 AP.1-88 ¼-nmi	1L	13.0	86.4	0.20	21.6	76.5	93.3
	2R	13.1	85.5	0.20	20.5	70.0	89.0
	3L	13.2	84.4	0.24	20	68.7	87.5
	7R	13.5	82.2	0.19	19	67.4	87.9
	8L	13.7	81.8	0.24	22	69.5	89.3
	9R	13.9	81.4	0.22	24	66.4	85.5
	10L	14.4	77.9	0.24	22.7	67.3	84.5
	11R	14.7	74.0	0.35	22	66.5	84.9
	13R	15.1	70.6	0.26	22.8	68.6	85.9
	14L	15.1	70.7	0.25	24.6	71.2	88.1
	17L	15.3	71.1	0.25	20.6	70.7	89.1
	18R	15.4	71.3	0.38	22.5	68.9	88.8
	19L	15.5	71.4	0.25	24.2	71.8	89.3
9/27/95 AP.1-88 C-nmi	1L	16.1	54.7	0.125	24.5	74.6	91.9
	2R	16.0	55.7	0.125	23.9	71.6	89.2
	3L	15.8	56.7	0.125	22.9	74.4	91.8
	6L	15.5	59.7	0.125	23.1	74.1	92.1
	7R	15.4	60.5	0.125	24.8	72.8	90.2
	9R	14.9	64.2	0.11	22	73.4	91.5
	10L	14.7	65.4	0.125	32.1	79.3	95.6
	11R	14.7	65.8	0.125	23.8	73.8	91.5
	12L	14.6	66.3	0.125	24.1	77.8	94.8
	15R	14.5	66.9	0.13	23	75.6	91.7
	16L	14.5	67.1	0.13	25	78.2	95.6
	17R	14.5	67.4	0.125	23.7	75.6	92.9
	19R	13.7	69.3	0.21	23.38	76.8	94.4
20L	13.5	69.8	0.125	23.2	79.0	96.4	
9/27/95 LACV-30 C-nmi	1R	10.2	85.6	0.122	30 (est.)	96.1	107.2
	2L	10.1	85.9	0.125	30 (est.)	96.1	109.3
	3R	10.0	86.0	0.122	35 (est.)	97.1	109.5
	4L	9.9	86.3	0.125	35 (est.)	99.2	112.0
	5R	9.8	86.4	0.122	35 (est.)	99.6	110.6
	6L	9.7	86.6	0.125	35 (est.)	100.5	113.4
	7R	9.6	86.7	0.12	35 (est.)	98.7	110.8
	8L	9.6	86.8	0.122	35 (est.)	100.7	113.6



U.S. Department  
of Transportation

Research and  
Special Programs  
Administration

Voice Center  
Acoustics Facility

March, 1996

Table B-2. As-Measured DAT Pass-by Data

Test Date / Craft	Event	Meteorological Data		As-Measured Data			
		Temperature (°C)	Humidity (% RH)	Distance (nmi)	Speed (kts)	L <sub>ASmx</sub> (dB)	L <sub>AAR</sub> (dB)
9/25/95 AP.1-88 ¼-nmi	1L	13.0	86.4	0.20	21.6	76.0	93.3
	2R	13.1	85.5	0.20	20.5	69.9	88.9
	3L	13.2	84.4	0.24	20	68.3	87.5
	7R	13.5	82.2	0.19	19	67.2	87.9
	8L	13.7	81.8	0.24	22	69.5	89.4
	9R	13.9	81.4	0.22	24	66.2	85.4
	10L	14.4	77.9	0.24	22.7	67.1	85.5
	11R	14.7	74.0	0.35	22	66.4	84.9
	13R	15.1	70.6	0.26	22.8	68.3	85.9
	14L	15.1	70.7	0.25	24.6	70.7	88.1
	17L	15.3	71.1	0.25	20.6	70.3	89.2
	18R	15.4	71.3	0.38	22.5	68.5	88.8
19L	15.5	71.4	0.25	24.2	71.1	89.2	
9/27/95 AP.1-88 C-nmi	1L	16.1	54.7	0.125	24.5	74.4	91.8
	2R	16.0	55.7	0.125	23.9	71.4	89.3
	3L	15.8	56.7	0.125	22.9	74.0	91.7
	6L	15.5	59.7	0.125	23.1	73.9	92.1
	7R	15.4	60.5	0.125	24.8	72.6	90.2
	9R	14.9	64.2	0.11	22	73.1	91.5
	10L	14.7	65.4	0.125	32.1	79.2	95.6
	11R	14.7	65.8	0.125	23.8	73.5	91.4
	12L	14.6	66.3	0.125	24.1	77.3	94.7
	15R	14.5	66.9	0.13	23	75.3	91.7
	16L	14.5	67.1	0.13	25	78.0	95.6
	17R	14.5	67.4	0.125	23.7	75.3	92.8
19R	13.7	69.3	0.21	23.38	76.3	94.3	
20L	13.5	69.8	0.125	23.2	78.6	96.2	
9/27/95 LACV-30 C-nmi	1R	10.2	85.6	0.122	30 (est.)	95.7	106.8
	2L	10.1	85.9	0.125	30 (est.)	95.6	108.9
	3R	10.0	86.0	0.122	35 (est.)	96.5	109.0
	4L	9.9	86.3	0.122	35 (est.)	98.2	111.6
	5R	9.8	86.4	0.122	35 (est.)	98.7	110.2
	6L	9.7	86.6	0.125	35 (est.)	99.8	112.9
	7R	9.6	86.7	0.12	35 (est.)	98.0	110.3
	8L	9.6	86.8	0.122	35 (est.)	100.7	113.2



Table B-3. As-Measured LD2900 Approach/Departure Data

Test Date / Craft	Event	Meteorological Data		As-Measured Data	
		Temperature (°C)	Humidity (% RH)	L <sub>ASmx</sub> (dB)	L <sub>AE</sub> (dB)
9/26/95 AP.1-88 ¼-nmi	1LA	12.6	77.4	86.7	98.9
	2RD	12.8	76.7	90.1	105.2
	3RA	13.3	75.3	81.0	95.9
	4RD	13.6	74.5	85.9	102.4
	5LA	14.1	73.3	81.8	95.8
	6LD	14.2	73.0	83.0	97.8
	8RA	14.8	71.2	79.8	95.2
	9RD	14.9	71.0	84.8	99.1
	10LA	15.5	69.1	80.1	92.8
	11LD	15.4	69.1	79.8	93.6
	14RD	15.1	69.4	81.2	96.3
	19RD	14.6	69.7	82.8	95.8
	20LA	14.5	69.8	79.4	91.0
	21LD	14.4	69.8	80.0	93.0
9/26/95 AP.1-88 C-nmi	2LA	14.9	66.0	79.9	92.9
	3LD	14.9	65.6	85.5	98.3
	4RA	15.1	64.7	79.0	92.6
	5RD	15.2	64.2	84.8	97.6
	6LA	15.4	63.0	79.2	93.0
	7LD	15.5	62.5	87.1	99.4
	8RA	15.7	61.3	78.3	93.1
	9RD	15.8	61.0	88.8	98.0
	10LA	15.9	60.0	78.4	93.1
	11LD	16.1	59.2	84.8	97.5



Table B-4. As-Measured DAT Approach/Departure Data

Test Date / Craft	Event	Meteorological Data		As-Measured Data	
		Temperature (°C)	Humidity (% RH)	L <sub>ASmx</sub> (dB)	L <sub>AE</sub> (dB)
9/26/95 AP.1-88 ¼-nmi	1LA	12.6	77.4	86.7	98.6
	2RD	12.8	76.7	90.8	105.0
	3RA	13.3	75.3	81.4	95.4
	4RD	13.6	74.5	86.1	102.2
	5LA	14.1	73.3	83.0	95.1
	6LD	14.2	73.0	82.9	97.5
	8RA	14.8	71.2	80.0	94.7
	9RD	14.9	71.0	84.9	98.8
	10LA	15.5	69.1	80.3	92.0
	11LD	15.4	69.1	80.2	93.3
	14RD	15.1	69.4	81.1	96.1
	19RD	14.6	69.7	82.7	95.4
	20LA	14.5	69.8	79.4	90.0
	21LD	14.4	69.8	80.4	92.8
9/26/95 AP.1-88 C-nmi	2LA	14.9	66.0	80.1	92.5
	3LD	14.9	65.6	84.9	98.0
	4RA	15.1	64.7	79.1	92.3
	5RD	15.2	64.2	84.2	96.7
	6LA	15.4	63.0	79.7	92.8
	7LD	15.5	62.5	87.3	99.3
	8RA	15.7	61.3	78.4	92.9
	9RD	15.8	61.0	88.8	97.9
	10LA	15.9	60.0	78.4	91.8
	11LD	16.1	59.2	85.0	97.4



## **Appendix C.**

### **CORRECTED PASS-BY DATA**

Appendix C presents the corrected pass-by data for all events processed. These data were corrected to 8 distances, as discussed in Section 4. Tables C-1 and C-2 present the overall, average- corrected data for each craft. The data presented in these Tables are identical to those in Tables 2 and 3 of Section 5.1.



March, 1996

**Table C-1. AP.1-88 Pass-by Data**  
Overall, Average-Corrected

Distance (m)	L <sub>ASmx</sub> (dB)	L <sub>AE</sub> (dB)
50	91.2	101.1
100	84.9	97.9
200	78.6	94.6
500	69.7	89.6
1000	62.4	85.3
2000	54.3	80.2
5000	41.7	71.6
10000	30.7	63.6

**Table C-2. LACV-30 Pass-by Data**  
Overall, Average-Corrected

Distance (m)	L <sub>ASmx</sub> (dB)	L <sub>AE</sub> (dB)
50	111.7	119.9
100	105.5	115.5
200	99.2	113.4
500	90.3	108.5
1000	82.9	104.1
2000	74.7	98.9
5000	62.4	89.7
10000	49.2	80.3





March, 1996

**Table C-3. AP.1-88 Pass-by Data  
Event 1L, 9/25/95**

Distance (m)	L <sub>ASmx</sub> (dB)	L <sub>AE</sub> (dB)
50	95.7	104.0
100	89.6	100.8
200	83.3	97.6
500	74.6	92.8
1000	67.4	88.7
2000	59.4	83.7
5000	46.9	75.1
10000	35.4	66.7

**Table C-4. AP.1-88 Pass-by Data  
Event 2R, 9/25/95**

Distance (m)	L <sub>ASmx</sub> (dB)	L <sub>AE</sub> (dB)
50	89.9	99.6
100	83.7	96.4
200	77.4	93.1
500	68.5	88.2
1000	61.3	84.0
2000	53.4	79.1
5000	41.1	70.7
10000	29.8	62.5

**Table C-5. AP.1-88 Pass-by Data  
Event 3L, 9/25/95**

Distance (m)	L <sub>ASmx</sub> (dB)	L <sub>AE</sub> (dB)
50	89.6	98.6
100	83.5	95.5
200	77.3	92.3
500	68.6	87.6
1000	61.5	83.5
2000	53.4	78.5
5000	40.3	69.3
10000	28.2	60.3

**Table C-6. AP.1-88 Pass-by Data  
Event 7R, 9/25/95**

Distance (m)	L <sub>ASmx</sub> (dB)	L <sub>AE</sub> (dB)
50	87.2	98.3
100	81.0	95.1
200	74.7	91.8
500	65.7	86.8
1000	58.4	82.6
2000	50.4	77.6
5000	38.3	69.5
10000	28.2	62.3

March, 1996



U.S. Department  
of Transportation

Research and  
Special Programs  
Administration

**Table C-7. AP.1-88 Pass-by Data**  
Event 8L, 9/25/95

Distance (m)	L <sub>ASmx</sub> (dB)	L <sub>AE</sub> (dB)
50	91.2	101.3
100	85.0	98.2
200	78.8	94.9
500	69.9	90.1
1000	62.7	85.8
2000	54.6	80.7
5000	41.5	71.6
10000	29.9	63.1

**Table C-8. AP.1-88 Pass-by Data**  
Event 9R, 9/25/95

Distance (m)	L <sub>ASmx</sub> (dB)	L <sub>AE</sub> (dB)
50	87.4	97.5
100	81.2	94.3
200	75.0	91.0
500	66.1	86.2
1000	58.9	82.0
2000	50.8	76.9
5000	38.2	68.3
10000	27.0	60.1

**Table C-9. AP.1-88 Pass-by Data**  
Event 10L, 9/25/95

Distance (m)	L <sub>ASmx</sub> (dB)	L <sub>AE</sub> (dB)
50	88.6	97.3
100	82.5	94.2
200	76.3	91.0
500	67.7	86.4
1000	60.7	82.4
2000	53.0	77.7
5000	40.6	69.3
10000	29.4	61.1

**Table C-10. AP.1-88 Pass-by Data**  
Event 11R, 9/25/95

Distance (m)	L <sub>ASmx</sub> (dB)	L <sub>AE</sub> (dB)
50	91.5	98.7
100	85.3	95.5
200	79.0	92.3
500	70.2	87.5
1000	63.0	83.2
2000	54.8	78.1
5000	41.6	68.8
10000	29.3	59.5

March, 1996



**Table C-11. AP.1-88 Pass-by Data**  
Event 13R, 9/25/95

Distance (m)	L <sub>ASmx</sub> (dB)	L <sub>AE</sub> (dB)
50	90.5	98.3
100	84.3	95.1
200	78.1	91.9
500	69.3	87.1
1000	62.1	82.9
2000	54.2	78.0
5000	41.7	69.5
10000	30.3	61.1

**Table C-12. AP.1-88 Pass-by Data**  
Event 14L, 9/25/95

Distance (m)	L <sub>ASmx</sub> (dB)	L <sub>AE</sub> (dB)
50	92.5	100.7
100	86.2	97.4
200	79.9	94.1
500	71.2	89.3
1000	64.1	85.3
2000	56.2	80.1
5000	43.5	71.6
10000	31.1	62.2

**Table C-13. AP.1-88 Pass-by Data**  
Event 17L, 9/25/95

Distance (m)	L <sub>ASmx</sub> (dB)	L <sub>AE</sub> (dB)
50	92.0	101.0
100	85.8	97.8
200	79.5	94.4
500	70.5	89.5
1000	63.2	85.2
2000	55.3	80.3
5000	43.4	72.3
10000	32.8	64.7

**Table C-14. AP.1-88 Pass-by Data**  
Event 18R, 9/25/95

Distance (m)	L <sub>ASmx</sub> (dB)	L <sub>AE</sub> (dB)
50	94.3	103.4
100	88.1	100.2
200	81.7	96.8
500	72.7	91.8
1000	65.4	87.5
2000	57.4	82.6
5000	46.0	75.2
10000	36.2	68.3

March, 1996

**Table C-15. AP.1-88 Pass-by Data**



Event 19L, 9/25/95

Distance (m)	L <sub>ASmx</sub> (dB)	L <sub>AE</sub> (dB)
50	92.8	101.7
100	86.5	98.5
200	80.2	95.1
500	71.1	90.1
1000	63.6	85.6
2000	55.4	80.4
5000	43.5	72.4
10000	33.2	65.2

**Table C-16. AP.1-88 Pass-by Data**  
Event 1L, 9/27/95

Distance (m)	L <sub>ASmx</sub> (dB)	L <sub>AE</sub> (dB)
50	89.4	100.6
100	83.2	97.4
200	76.9	94.1
500	67.1	89.1
1000	60.5	84.7
2000	52.2	79.5
5000	39.4	70.6
10000	28.6	62.8

**Table C-17. AP.1-88 Pass-by Data**  
Event 2R, 9/27/95

Distance (m)	L <sub>ASmx</sub> (dB)	L <sub>AE</sub> (dB)
50	86.6	98.1
100	80.4	94.9
200	74.0	91.5
500	65.0	86.6
1000	57.7	82.2
2000	49.6	77.1
5000	37.0	68.5
10000	26.4	60.9

**March, 1996**

**Table C-18. AP.1-88 Pass-by Data**  
Event 3L, 9/27/95

**Table C-19. AP.1-88 Pass-by Data**  
Event 6L, 9/27/95



U.S. Department  
of Transportation  
Federal Aviation  
Administration  
Vehicle Center  
Wash. D.C.

Distance (m)	L <sub>ASmx</sub> (dB)	L <sub>AE</sub> (dB)
50	89.5	100.6
100	83.2	97.3
200	76.8	93.9
500	67.4	88.5
1000	59.7	83.8
2000	51.2	78.4
5000	39.2	70.3
10000	29.4	63.5

Distance (m)	L <sub>ASmx</sub> (dB)	L <sub>AE</sub> (dB)
50	89.4	100.9
100	83.2	97.7
200	76.9	94.3
500	67.9	89.4
1000	60.5	85.0
2000	52.2	79.7
5000	39.2	70.7
10000	28.5	63.0

**Table C-20. AP.1-88 Pass-by Data**  
Event 7R, 9/27/95

**Table C-21. AP.1-88 Pass-by Data**  
Event 9R, 9/27/95

Distance (m)	L <sub>ASmx</sub> (dB)	L <sub>AE</sub> (dB)
50	88.4	99.5
100	82.1	96.3
200	75.7	92.9
500	66.6	87.8
1000	59.2	83.3
2000	51.0	78.2
5000	38.6	69.8
10000	27.9	62.2

Distance (m)	L <sub>ASmx</sub> (dB)	L <sub>AE</sub> (dB)
50	87.8	99.6
100	81.7	96.4
200	75.4	93.1
500	66.6	88.3
1000	59.4	84.1
2000	51.3	79.1
5000	38.4	70.1
10000	26.8	61.5

**March, 1996**

**Table C-22. AP.1-88 Pass-by Data**  
Event 10L, 9/27/95

**Table C-23. AP.1-88 Pass-by Data**  
Event 11R, 9/27/95

Distance (m)	L <sub>ASmx</sub> (dB)	L <sub>AE</sub> (dB)
-----------------	---------------------------	-------------------------

Distance (m)	L <sub>ASmx</sub> (dB)	L <sub>AE</sub> (dB)
-----------------	---------------------------	-------------------------



U.S. Department of Transportation  
 Research and Special Programs Administration  
 Vehicle Center  
 Noise Lab

50	95.2	104.7
100	89.0	101.5
200	82.7	98.1
500	73.7	93.1
1000	66.3	88.8
2000	58.1	83.6
5000	45.7	75.2
10000	35.2	67.7

50	89.6	100.7
100	83.4	97.5
200	77.1	94.1
500	68.1	89.1
1000	60.7	84.8
2000	52.6	79.7
5000	40.0	71.1
10000	28.8	62.9

**Table C-24. AP.1-88 Pass-by Data**  
 Event 12L, 9/27/95

Distance (m)	L <sub>ASmx</sub> (dB)	L <sub>AE</sub> (dB)
50	93.6	104.2
100	87.4	101.0
200	81.1	97.6
500	72.1	92.6
1000	64.7	88.2
2000	56.4	83.0
5000	43.9	74.4
10000	33.1	66.6

**Table C-25. AP.1-88 Pass-by Data**  
 Event 15R, 9/27/95

Distance (m)	L <sub>ASmx</sub> (dB)	L <sub>AE</sub> (dB)
50	92.0	101.3
100	85.8	98.0
200	79.3	94.6
500	70.1	89.4
1000	62.5	84.7
2000	54.0	79.2
5000	41.2	70.4
10000	30.2	62.5

**March, 1996**

**Table C-26. AP.1-88 Pass-by Data**  
 Event 16L, 9/27/95

Distance (m)	L <sub>ASmx</sub> (dB)	L <sub>AE</sub> (dB)
50	94.3	105.2

**Table C-27. AP.1-88 Pass-by Data**  
 Event 17R, 9/27/95

Distance (m)	L <sub>ASmx</sub> (dB)	L <sub>AE</sub> (dB)
50	91.6	102.3



Equipment Specification	100	88.1	102.0
Research and Special Programs Administration	200	81.8	98.7
Virginia Center for Transportation Research	500	73.0	93.8
	1000	65.7	89.6
	2000	57.8	84.7
	5000	46.0	76.9
	10000	36.0	69.9

	100	85.4	99.0
	200	78.9	95.5
	500	69.6	90.3
	1000	61.9	85.5
	2000	53.3	80.0
	5000	40.8	71.4
	10000	30.2	63.9

**Table C-28. AP.1-88 Pass-by Data  
Event 19R, 9/27/95**

Distance (m)	L <sub>ASmx</sub> (dB)	L <sub>AE</sub> (dB)
50	96.2	105.4
100	90.0	102.2
200	83.8	99.0
500	75.0	94.2
1000	67.8	90.0
2000	59.6	84.8
5000	45.8	75.0
10000	31.7	63.9

**Table C-29. AP.1-88 Pass-by Data  
Event 20L, 9/27/95**

Distance (m)	L <sub>ASmx</sub> (dB)	L <sub>AE</sub> (dB)
50	94.7	105.4
100	88.4	102.2
200	82.0	98.7
500	72.8	93.5
1000	65.2	88.9
2000	56.9	83.6
5000	44.7	75.4
10000	34.4	68.1

**March, 1996**

**Table C-30. LACV-30 Pass-by Data  
Event 1R, 9/27/95**

Distance (m)	L <sub>ASmx</sub> (dB)	L <sub>AE</sub> (dB)
50	109.9	115.9
100	103.7	112.7

**Table C-31. LACV-30 Pass-by Data  
Event 2L, 9/27/95**

Distance (m)	L <sub>ASmx</sub> (dB)	L <sub>AE</sub> (dB)
50	110.0	118.2
100	103.7	115.0



U.S. Department of Transportation	200	97.4	109.5
Research and Special Programs Administration	500	88.6	104.6
Vehicle Center	1000	81.3	100.3
Test Facility	2000	73.1	95.1
	5000	59.8	85.9
	10000	47.1	76.2

	200	97.4	111.6
	500	88.4	106.6
	1000	81.0	102.2
	2000	72.6	96.8
	5000	59.3	87.5
	10000	47.4	78.6

**Table C-32. LACV-30 Pass-by Data  
Event 3R, 9/27/95**

Distance (m)	L <sub>ASmx</sub> (dB)	L <sub>AE</sub> (dB)
50	110.4	118.6
100	104.3	115.5
200	98.1	112.2
500	89.3	107.5
1000	82.3	103.4
2000	74.4	98.6
5000	61.7	89.9
10000	49.1	80.2

**Table C-33. LACV-30 Pass-by Data  
Event 4L, 9/27/95**

Distance (m)	L <sub>ASmx</sub> (dB)	L <sub>AE</sub> (dB)
50	112.3	121.4
100	106.1	118.2
200	99.8	114.9
500	90.9	110.0
1000	83.7	105.8
2000	75.7	100.8
5000	62.9	92.0
10000	51.0	83.1

**March, 1996**

**Table C-34. LACV-30 Pass-by Data  
Event 5R, 9/27/95**

Distance (m)	L <sub>ASmx</sub> (dB)	L <sub>AE</sub> (dB)
50	112.6	119.8
100	106.3	116.6
200	100.0	113.3

**Table C-35. LACV-30 Pass-by Data  
Event 6L, 9/27/95**

Distance (m)	L <sub>ASmx</sub> (dB)	L <sub>AE</sub> (dB)
50	113.7	122.6
100	107.4	118.4
200	101.1	116.1



500	91.0	108.3
1000	83.6	103.8
2000	75.1	98.4
5000	61.6	88.9
10000	48.7	78.9

500	92.2	111.1
1000	84.8	106.7
2000	76.4	101.4
5000	62.9	91.9
10000	50.6	82.6

**Table C-36. LACV-30 Pass-by Data**  
Event 7R, 9/27/95

Distance (m)	$L_{ASmx}$ (dB)	$L_{AE}$ (dB)
50	111.4	119.7
100	105.2	116.5
200	98.9	113.2
500	89.9	108.3
1000	82.6	104.0
2000	74.4	98.8
5000	61.4	89.7
10000	48.9	80.3

**Table C-37. LACV-30 Pass-by Data**  
Event 8L, 9/27/95

Distance (m)	$L_{ASmx}$ (dB)	$L_{AE}$ (dB)
50	113.6	122.6
100	107.3	119.5
200	101.0	116.1
500	92.1	111.2
1000	84.7	106.8
2000	76.3	101.4
5000	62.9	92.0
10000	50.6	82.7

## Appendix D.

### Corrected One-Third Octave-Band Spectral Data

Appendix D presents the un-weighted, one-third octave-band spectral data measured at the time of  $L_{ASMC}$  for all pass-by events. These data were corrected to 305 m (1000 ft) and standard day atmospheric conditions (15°C and 70% RH).



U.S. ENVIRONMENTAL PROTECTION AGENCY  
OFFICE OF RESEARCH AND DEVELOPMENT  
NATIONAL CENTER FOR ENVIRONMENTAL ASSESSMENT  
WASHINGTON, D.C. 20460

March, 1996

**Table D-1. Corrected One-Third Octave-Band (Un-weighted)  
Pass-by Spectral Data at 305 m (1000 ft)**



## APPENDIX E.

### ASSESSMENT OF COMMUNITY NOISE IMPACT DUE TO HOVERCRAFT

As discussed in Section 5.4, Appendix E presents a computational example of using the data measured in the current study to compute noise levels at a receiver location subject to hovercraft operation typical of those that are proposed in the vicinity of Bethel, AK. Computations are performed using the **average day-night sound level (DNL, represented by the symbol  $L_{dn}$ )** descriptor. The  $L_{dn}$  descriptor is the most commonly used noise descriptor for assessing community noise impact. Assuming all hovercraft operations occur between 0700 and 2200 hours, local time, the general equation for  $L_{dn}$  can be simplified to the following:

$$L_{dn} = L_{AE} + 10 \times \log_{10}(N) - 49.4 \quad (\text{dB}),$$

where  $L_{AE}$  = Sound Exposure Level, as defined in the terminology section of this report

and  $N$  = number of operations between 0700 and 2200 hours, local time.

assuming all operations occur between 0700 and 2100 local time. Also, given this assumption,  $L_{dn} = L_{Aeq,24h}$ .

Note: Given the assumption that all hovercraft operations occur between 0700 and 2200 hours, local time,  $L_{dn}$  is equivalent to  $L_{Aeq,24h}$ , a noise descriptor which is discussed below.

Figures E1 through E4 show " $L_{dn}$  or  $L_{Aeq,24h}$ " versus distance for a single operation of the AP.1-88 hovercraft. Figures E1 and E2 illustrate pass-by configuration data, Figure E2 zooming in on the 50 to 1000 m range. These data are nothing more than a graphical representation of

the  $L_{AE}$  data presented in Table 2 (Section 5.1), with a constant value of 49.4 dB subtracted. The 49.4 dB is simply a normalization constant which spreads the **acoustic energy** associated with hovercraft operations over a 24 hour period, i.e.,  $10 \times \log_{10}(86,400 \text{ sec per day}) = 49.4 \text{ dB}$ . Figures E3 and E4 illustrate approach/departure configuration data, Figure E4 zooming in on the 50 to 1000 m range.

The pass-by curves (Figures E1 and E2) are conservative estimates that assume propagation over an "**acoustically hard**" surface (e.g. water or concrete). Note: It is expected that propagation for the pass-by operations will occur primarily over water in the vicinity of Bethel, AK, since the Postal Service has required that all operations associated with the proposed mail transport service take place on the area waterways.

Three curves are drawn for the approach/departure data (Figures E3 and E4). These were derived using a single, average value for all measurements, denoted by the "boxed asterisk." The middle curve, originating at the known data point, represents **sound absorption** over an "**acoustically soft**" surface. It is drawn assuming a slope of 7.5 dB per doubling of distance (dB/dd) which is considered typical over ground types such as short-grass-covered terrain. The lower curve (greater ground attenuation effect, re the 7.5 dB/dd curve) represents **sound absorption** over softer, more absorptive ground, typical of thick vegetation or terrain covered with freshly fallen snow. The upper curve (less ground attenuation effects, re the 7.5 dB/dd curve) represents **sound absorption** over an "**acoustically hard**" surface. For all computations presented herein and for independent application of the assessment methodology presented in this Appendix, it is recommended that the upper, more conservative curve be used, unless detailed information is available. This conservative approach ensures that any errors inherent in the process will result in an over-prediction of the noise levels.

The following is a sample  $L_{dn}$  computation, typical of what may be encountered for a village in the vicinity of Bethel, AK:

Given:     3 pass-by operations per week;  
          3 approach/departure operations per week;  
          a pass-by distance to the nearest residential structure (at  
          closest-point-of-approach) of 305 m (1000 ft);  
          a distance of 61 m (200 ft) between landing site and nearest  
          residential structure;

Step 1:    Use the " $L_{dn}$  or  $L_{Aeq24h}$ " curve (either Figure E1 or E2) to  
          obtain the  $L_{dn}$  value for a pass-by distance of 305 m

$$L_{dn}(\text{pass-by}) = 43.0 \text{ dB}$$

Step 2:    Use the uppermost " $L_{dn}$  or  $L_{Aeq24h}$ " curve (either Figure E3 or  
          E4) to obtain the  $L_{dn}$  value for an approach\departure at a  
          distance of 61 m

$$L_{dn}(\text{app/dep}) = 46.0 \text{ dB}$$

Note:    The  $L_{dn}$  values found in Steps 1 and 2 are for one operation  
          only. The remainder of the steps must be carried through in order  
          to calculate a final  $L_{dn}$ .

Step 3: Using "dB-addition", calculate the overall  $L_{dn}$ .

$$43.0 \text{ dB} + 46.0 \text{ dB} = 10 \times \log(10^{0.1(43.0)} + 10^{0.1(46.0)}) = 47.8 \text{ dB}$$

Step 4: Compute the average number of daily approach/departure operations and pass-by operations.

3 approach/departures per week = 0.43 operations per day

3 pass-bys per week = 0.43 operations per day

Note: These calculations assume that all operations occur between 0700 and 2200 hours local time. If this is not the case, this process is not applicable.

Step 5: Compute  $L_{dn}$  taking into account actual operations.

$$L_{dn(w/ops)} = 47.8 \text{ dB} + 10 \times \log_{10}(0.43 + 0.43) = 47.1 \text{ dB}$$

**Final  $L_{dn} = 47.1 \text{ dB}$**

This final level can now be compared with two commonly referenced noise impact criteria, that of the FAA<sup>14</sup> and that of the Federal Transit Administration (FTA)<sup>15</sup>. FAA uses a 65 dB  $L_{dn}$  limit for determining noise-compatible residential land use. In addition, assuming an ambient noise level of 40 dB as representative, FTA criteria state that "no impact" occurs when project noise levels, in this case noise levels due to hovercraft operations, are less than approximately 50 dB (" $L_{dn}$  or  $L_{eq}$ "). In the case of the above example, both criteria are satisfied.













Center for the Study of Language  
Department of Linguistics  
University of Toronto  
270 Spadina Avenue  
Toronto, Ontario M5S 2A5  
Canada

March, 1996



U.S. ENVIRONMENTAL  
PROTECTION AGENCY  
OFFICE OF RESEARCH AND  
DEVELOPMENT  
NATIONAL CENTER FOR  
ENVIRONMENTAL QUALITY  
CRITERIA DEVELOPMENT  
UNIT

Figure E-1.  $L_{dn}$  or  $L_{Aeq24h}$  vs. Distance - Pass-by

March, 1996



U.S. ENVIRONMENTAL  
PROTECTION AGENCY  
OFFICE OF RESEARCH AND  
DEVELOPMENT  
NATIONAL CENTER FOR  
ENVIRONMENTAL QUALITY  
CRITERIA DEVELOPMENT  
UNIT

Figure E-2.  $L_{dn}$  or  $L_{Aeq24h}$  vs. Distance - Pass-by

March, 1996





Figure E-4.  $L_{dn}$  or  $L_{Aeq24h}$  vs. Distance - Approach/Departure

## **APPENDIX F.**

### **STATEMENT OF HOVERCRAFT CONFIGURATION**

Appendix F presents a memo from Dave Seaman (Alaska Hovercraft) to Tom Rutledge (Postal Service) and Gregg Fleming (Volpe Center), dated September 28, 1995. It certifies that the hovercraft used during the study is the same configuration as proposed for use in the vicinity of Bethel, AK.



## APPENDIX G.

### REFERENCES

1. "Standard Values of Atmospheric Absorption as a Function of Temperature and Humidity," Society of Automotive Engineers, SAE, Committee A-21, New York, NY. March 1975.
2. Schomer, P. D., Report Number N-85/04: Operational Noise Data for the LACV-30 Light Air Cushion Vehicle, US Army Construction Engineering Research Laboratory, Champaign, IL. March 1985.
3. Dvornak, M., Interoffice Memo: LACV-30/Voyager Noise Levels @ Low Power, Textron Marine & Land Systems, New Orleans, LA. April 14, 1995.
4. Dickins, D.F., Stikine/Iskut River Hovercraft Operations: Environmental Summary, DF Dickins Associates Ltd., Vancouver, British Columbia. June 14, 1990.
5. Fleming, G. G., Roof, C. J., Test Plan: Noise Characterization Study for AP.1-88 Hovercraft, Letter Report No. DTS-75-VR563-LR1, John A. Volpe National Transportation Systems Center, Cambridge, MA. August 1995.
6. Federal Aviation Regulations, Part 36, Noise Standards: Aircraft Type and Airworthiness Certification, Federal Aviation Administration, Washington, D.C. September 1992.
7. Lee, C.S., Fleming, G.G., Recommended Practice for the Measurement and Assessment of Highway Traffic Noise, John A. Volpe National Transportation Systems Center, Cambridge, MA. (to be published).
8. "Method for the Calculation of Absorption of Sound by the Atmosphere," New York, NY: American National Standards Institute (ANSI), ANSI Standard S1.26-1978.
9. Fleming, G. G., Roof, C. J., Interoffice Memorandum: Preliminary Results of AP1-88 Characterization Study, John A. Volpe National Transportation Systems Center, Cambridge, MA. October 5, 1995.
10. Olmstead, et al, Integrated Noise Model (INM) Version 5.0 User's Guide, FAA-AEE-95-01, U.S. Department of Transportation, Federal Aviation Administration, Office of Environment and Energy, Washington D.C. August 1995.
11. Moulton, C. L., Air Force Procedure For Predicting Aircraft Noise Around Airbases: NoiseExposure Model (NOISEMAP) User's Manual, Report No. AAMRL-TR-011, Wyle Laboratories, El Segundo, CA.

February, 1990.

12. Fleming, et al, Development of National Reference Energy Mean Emission Levels for the FHWA Traffic Noise Model, FHWA-PD-96-008, John A Volpe National Transportation Systems Center, Cambridge, MA. November, 1995.
13. Bowlby, W., et al, 1995 Noise Monitoring Study Grand Teton National Park and John D. Rockefeller Jr. Memorial Parkway, Wyoming, Bowlby and Associates, Brentwood, TN. June, 1995.
14. Federal Aviation Regulations, Part 150, Airport Noise Compatibility Planning, U.S. Department of Transportation, Federal Aviation Administration, Washington, D.C. October 25, 1989.
15. Hanson, C.E., et al, Transit Noise and Vibration Impact Assessment, U.S. Department of Transportation, Federal Transit Administration, Washington, D.C. April 1995.

## APPENDIX H.

### INDEX

A-weighted . . . . .	8,13
Acoustic data sets . . . . .	17
Acoustic energy . . . . .	8,10,32,33
Acoustic Instrumentation . . . . .	7
Acoustics Facility . . . . .	1
Aircraft . . . . .	2,4,14,17
first-generation commercial jet . . . . .	2
intrusion . . . . .	14
military . . . . .	2
noise studies . . . . .	4
Alaska Hovercraft . . . . .	4,12,14
Anchorage International Airport . . . . .	14
As-measured data . . . . .	18,32
Approach/departure operation . . . . .	12,33,35
Atmospheric effects . . . . .	17
B&K Model 4231 sound-level calibrators . . . . .	9
Cetec Ivie . . . . .	9
Communication Instrumentation . . . . .	10
Cook Inlet . . . . .	5
DAT Recorder . . . . .	9
DAT tapes . . . . .	18
Data Reduction . . . . .	17
dB . . . . .	13
Department Environmental Policy . . . . .	1
Department of Transportation . . . . .	1
Deutz 390 HP . . . . .	3
Deutz 500 HP . . . . .	3
Diesel marine engine . . . . .	3
Directivity effect . . . . .	14,15
Distance-duration correction . . . . .	24,26
Electret-condenser microphones . . . . .	7
Electronic noise floor . . . . .	9,15
Energy-averaging . . . . .	21
Energy-subtraction of pre detection noise . . . . .	20
Environmental Assessment . . . . .	1
Experimental Approach . . . . .	11
FAA . . . . .	19
Field-data log sheets . . . . .	9
Fire Island . . . . .	5, 10, 11
Fluorescent orange buoys . . . . .	10
GLR . . . . .	9, 13,19
GPS . . . . .	10
Graphic Level Recorder . . . . .	9
Grazing incidence . . . . .	7
Hovercraft . . . . .	1, 7, 10, 13, 14
AP.1-88 . . . . .	1-2
Land Systems Lighter Air Cushion Vehicle-30 . . . . .	1
closest-point-of-approach . . . . .	18

crew . . . . .	10, 13
Guidance . . . . .	10
mail transport service . . . . .	5
routes . . . . .	12
test paths . . . . .	11
on-board radio . . . . .	10
Humidity data . . . . .	10, 18
LACV-30 . . . . .	1-4, 10, 14
L <sub>AE</sub> . . . . .	17
Larson Davis Model 2900 . . . . .	8
L <sub>ASmx</sub> . . . . .	8, 17
Mail transport service . . . . .	3
Marine engines . . . . .	3
Measurement instrumentation . . . . .	7
Measurement-site crew . . . . .	10
Meteorological conditions . . . . .	9
Data . . . . .	17
Instrumentation . . . . .	9
Microphone . . . . .	7, 8, 9, 12, 18
Locations . . . . .	12
positions . . . . .	12
simulators . . . . .	9
diaphragms of . . . . .	7
National Transportation Systems Center . . . . .	1
Noise Characterization . . . . .	1
Non-masked band . . . . .	22
North Point . . . . .	11
Octave Band Spectrum Analyzer . . . . .	8
On-board Echotec Model CTM951 Global Positioning System . . . . .	10
On-board Raytheon Mariners Pathfinder Model 1210 . . . . .	10
On-line data . . . . .	8
Over-water operations . . . . .	12
Postal Service . . . . .	1, 4, 14
Preamplifier	
General Radio Model 1560-P42 . . . . .	7
combinations . . . . .	7
system . . . . .	8
PROII Digital Audio Tape Recorder Model TCD D10 . . . . .	8
Proposed Village Mail Delivery Schedule . . . . .	14
Psychrometer . . . . .	9
Radar system- Raytheon Model 4804c color . . . . .	10
Radio . . . . .	10
communication . . . . .	13
GP300 portable . . . . .	10
silence . . . . .	13
Random-noise generators . . . . .	9
Recorded Noise Data . . . . .	18
Schomer . . . . .	2
SPL . . . . .	19-23, 26
Slow-scale . . . . .	22, 23
Support Instrumentation . . . . .	9
Susceptibility ocean-related noise disturbances . . . . .	11
Test	
Procedures . . . . .	13
Site . . . . .	5, 11
Tidal changes . . . . .	12

Time-averaged sample of data . . . . .	20
Time-averaging function . . . . .	23
Time-of-day . . . . .	19,22
Topography . . . . .	11
Tracking	
Data . . . . .	18
Instrumentation . . . . .	10
Volpe Center . . . . .	1, 2, 4, 14
Acoustics Facility . . . . .	18
Field-measurement Test Plan . . . . .	13
Weather changes . . . . .	9
Wind-generated noise . . . . .	7
Windscreen	
B&K Model UA0237 . . . . .	7
incidence corrections . . . . .	21