



*U.S. Department  
of Transportation*

***Federal Motor Carrier Safety  
Administration***

---

***Performance-Based Brake Testers  
Round Robin Final Report***

***DOT-MC-00-100***

***February 2000***

---

*This document is available to the public from the National Technical Information Service, Springfield, Virginia 22161.*

<b>1. Report No.</b> DOT-MC-00-100	<b>2. Government Accession No.</b> PB2000-105555	<b>3. Recipient's Catalog No.</b>	
<b>4. Title and Subtitle</b> Performance-Based Brake Testers Round Robin Final Report		<b>5. Report Date</b> February, 2000	
		<b>6. Performing Organization Code</b>	
<b>7. Author(s)</b> S.J. Shaffer & A.-C. Christiaen		<b>8. Performing Organization Report No.</b>	
<b>9. Performing Organization Name and Address</b> Battelle Memorial Institute 505 King Avenue Columbus, OH 43201		<b>10. Work Unit No. (TRAIS)</b>	
		<b>11. Contract or Grant No.</b> DTFH61-96-C-00077	
<b>12. Sponsoring Agency Name and Address</b> Federal Motor Carrier Safety Administration		<b>13. Type of Report and Period Covered</b> Final Report covering Tests Conducted July 27-29, 1998	
		<b>14. Sponsoring Agency Code</b>	
<b>15. Supplementary Notes</b> The work was originally carried out under the USDOT, Federal Highway Administration, Office of Motor Carriers. The current supporting organization is the Federal Motor Carriers Safety Administration (FMCSA).			
<b>16. Abstract</b> <p>This report documents the results of a series of tests in which several different types of performance-based brake testers (PBBTs) were compared side-by-side (i.e. a round robin test) in their ability to accurately measure brake forces (BFs) and wheel loads (WLs) of commercial vehicles (CVs), and to then predict the vehicle deceleration capability for a 32.2 km/hr on-road stopping test. The PBBTs consisted of five roller dynamometers (RD), two flat plate (FP) testers, and one breakaway torque tester (BTT). A PBBT that can also meet a set of functional specifications could be used for law enforcement by safety inspectors once performance-based criteria are codified. In the test program, specific ratios of BF to WL were imposed on both a 5-axle combination tractor semi-trailer and a two-axle straight truck, in both the fully laden and unladen conditions. In each loading condition, the overall vehicle braking capability was set to achieve a proposed minimum requirement of 0.4g, where g is the acceleration due to gravity. In addition, the brakes on specific individual wheels were set to provide a BF/WL of 0.25 and 0.35, for a steer and a non-steer wheel, respectively. The vehicles were also instrumented to record stopping distances and decelerations from on-road stopping tests performed from 32.2 km/hr. In general, nearly all of the PBBTs were able to accurately measure the CVs' brake forces. Only one of the FP-type testers experienced erratic performance during the round robin. In contrast, several of the PBBTs had difficulty in reporting the accurate gross vehicle weight. In some cases, particularly with the portable PBBTs, the reported wheel loads for axles 2 and 4 (the lead axle on the tandem set) of the 5-axle vehicle were very high, leading to an under-prediction of the vehicle deceleration capability. Calibration checks of the PBBT weighing mechanisms indicated that all could meet the functional specifications. As such, it was concluded that accounting for the redistribution of axle loads due to the vehicle suspension and the geometry of the PBBT ramp would require special test procedures or remote entry of vehicle or axle weights for use in law enforcement. The repeatability of all the PBBTs was good, meeting the acceptability criteria in more than 93 percent of the test cases.</p>			
<b>17. Key Words</b> brakes, brake tester, brake testing, performance-based, commercial vehicle, PBBT, deceleration, road stop, stopping distance, roller dynamometer, flat plate, breakaway torque		<b>18. Distribution Statement</b> No restrictions. This document is available to the public through the National Technical Information Service, Springfield, VA 22161.	
<b>19. Security Classif. (of this report)</b> N/A	<b>20 Security Classif. (of this page)</b> N/A	<b>21. No. of Pages</b> Body: 62 Appendices: 70 Total: 132	<b>22. Price</b>

## **Notice**

This document is disseminated under the sponsorship of the Department of Transportation in the interest of information exchange. The United States Government assumes no liability for its contents or use thereof. This report does not constitute a standard, specification, or regulation.

The United States Government does not endorse products or manufacturers. Trade and manufacturers' names appear in this report only because they are considered essential to the object of the document.

## Abbreviations and Symbols

ARR	Acceptable Repeatability Range
BF	Brake Force
$BF_{\max}$	Maximum Brake Force
$BF_{\min}$	Minimum Brake Force
$BF_{\text{REF}}$	Reference Brake Force
$BF_{\text{TOT}}$	Total Brake Force
B&G	B&G Engineering
BTT	Breakaway Torque Tester
CFR	Code of Federal Regulations
COF	Coefficient Of Friction
CV	Commercial Vehicle
CVSA	Commercial Vehicle Safety Alliance
Decel	Deceleration
$\text{Decel}_{\text{EQ}}$	Equivalent Deceleration, $BF_{\text{TOT}}/\text{GVW}$
$\text{Decel}_{\text{REF}}$	Reference Deceleration
DOT	Department of Transportation
F	Friction Force
FHWA	Federal Highway Administration
FMCSA	Federal Motor Carrier Safety Administration
FMCSR	Federal Motor Carrier Safety Regulation
FMVSS	Federal Motor Vehicle Safety Standard
FP	Flat Plate Brake Tester
GAWR	Gross Axle Weight Rating
GVW	Gross Vehicle Weight
$GVW_{\text{REF}}$	Reference Gross Vehicle Weight
GVWR	Gross Vehicle Weight Rating
HEI	Hicklin Engineering, Inc.
MCSAP	Motor Carrier Safety Assistance Program
N	Normal Force
NHTSA	National Highway Traffic Safety Administration
OMCS	Office of Motor Carrier Safety
PB	Parking Brake
PBBT	Performance-Based Brake Tester
RAI	Radlinski and Associates, Inc.
RD	Roller Dynamometer
RR	Rolling Resistance
TRC	Transportation Research Center
VIS	Vehicle Inspection System
VRTC	Vehicle Research & Test Center
WL	Wheel Load
$\mu$	Coefficient of Friction

## Acknowledgements

This work was supported by the US Department of Transportation, Federal Highway Administration-Office of Motor Carrier and Highway Safety, under contracts DTFH61-93-C-00055 and DTFH61-96-C-00077. Specifically, Paul Alexander, Katherine K. Hartman, Steve Keppler, Larry W. Minor and Gary Woodford deserve recognition for their efforts and invaluable contributions.

We would also like to thank all the vendors/manufacturers and their guests for participating in this one of a kind event:

B&G Engineering (B&G):	Stanley J. Ball, Larry Gardner and Tom Cantlon.
HEKA:	Horst Behncke, Herbert and Bridget Kallinich, Tomas Miller, Ron Martoia, Gail and Sherry Brockie.
Hicklin Engineering, Inc. (HEI):	Scott Giles, Randy Nation, Jack Campbell and Jim Anderson.
Hunter Engineering, Inc. (Hunter):	Steve Balsarotti and Pete Liebetreu.
Radlinski and Associates, Inc. (RAI):	Richard Radlinski, Mark Flick and Richard Woodruff (Woody).
BM Autoteknik Moldrup ApS:	Mogens Norlem.
Vehicle Inspection Systems (VIS):	Miles Fuller, Murray Stewart, Larry Smith and Bob Fisher.

Special thanks go to all of the VRTC staff for their exceptional involvement in the round robin, in particular W. Riley Garrott, Lyle Heberling and Dick Hoover.

The following participants to the round robin shall not go unmentioned:

Ohio State Highway Patrol:	James R. Feddern, Lt. Randy Meek, Larry Nanna, Sgt. Bob Knauff, Doug Skotsky, Fred Pape, Sam Roetter and Dutch Orbich
Maryland DOT State Highway Authority:	John Rotz and Rick Davis
West Virginia Public Service Commission:	Bob R. Brooks and Dennis Teter
Commonwealth of Kentucky:	Jeff Bibb and Ed Lodgson
IRISystems:	Wilf Wedding
SAAQ:	Jacques Richard
H&M Ltd. Motor Vehicle Test Equipment:	W. H. Brown
Dennis NationalLease:	Dennis J. McNichol, III

We would also like to thank our colleagues, Jerry Kannel and Terry Merriman, for their assistance with this report.

Special mention goes to Serge Carignan of Ecole Polytechnique de Montreal, Dick Radlinski of RAI and Daniel D. Filiatrault of ICBC for sharing their outstanding photographs with us.

# Table of Contents

	Page
Notice .....	i
Abbreviations and Symbols .....	ii
Acknowledgements .....	iii
Executive Summary .....	vii
1 Introduction .....	1
1.1 Background .....	1
1.2 Objectives .....	3
1.3 Method of evaluation .....	3
2 Experimental details .....	5
2.1 Test stations .....	5
2.2 Vehicle descriptions .....	5
2.3 Test matrix .....	7
2.3.1 Part 1 – Vehicles with weak brakes .....	7
2.3.2 Part 2 – Vehicles with fully-adjusted strong brakes .....	8
2.4 Target vehicle set-up .....	9
2.4.1 Brake forces .....	9
2.4.2 Weights .....	10
3 Results .....	12
3.1 Vehicles with weak brakes (Tests 1-4) .....	12
3.1.1 Brake forces – Individual brake force evaluation – accuracy .....	13
3.1.2 Brake forces – Overall vehicle brake force evaluation - applicability .....	16
3.1.3 Wheel loads – Individual wheel load evaluation – accuracy .....	19
3.1.4 Wheel loads – Overall vehicle (GVW) evaluation – applicability .....	20
3.1.5 Decel <sub>EQ</sub> – Overall vehicle evaluation – applicability .....	22

3.1.6	Repeatability .....	24
3.1.6.1	Repeatability for individual weak brake BFs .....	24
3.1.6.2	Repeatability for overall GVW .....	25
3.1.6.3	Repeatability for overall vehicle deceleration .....	25
3.2	Vehicles with fully-adjusted, strong brakes (Tests 5-9) .....	30
3.2.1	Applicability of predicted $decel_{EQ}$ and $BF_{TOT}$ .....	30
3.2.2	Repeatability .....	40
3.2.2.1	Repeatability for overall GVW .....	40
3.2.2.2	Repeatability for strong BFs .....	40
3.2.3	Effect of test surface .....	42
4	Conclusions .....	45
5	Remaining Challenges .....	47

## Figures

Figure 1.	Identification of wheel numbers on the two test vehicles .....	6
Figure 2.	Target brake-force-to-wheel-load ratios .....	10
Figure 3.	Average deviation of PBBT-reported brake force per wheel from the brake force computed from the torque wheel data .....	15
Figure 4.	Tests 1-4, weakly braked vehicles: $BF_{TOT}$ .....	17
Figure 5.	Maximum deviation of PBBT-reported WL for concrete blocks of known weights.....	19
Figure 6.	Tests 1-4, weakly braked vehicles: GVW .....	21
Figure 7.	Tests 1-4, weakly braked vehicles: $decel_{EQ}$ .....	23
Figure 8.	Repeatability of PBBT-reported BF measurements for weak brakes on the 3-S2 vehicle (Tests 1 and 3) .....	26
Figure 9.	Repeatability of PBBT-reported BF measurements for weak brakes on the 2-axle vehicle (Tests 2 and 4) .....	27
Figure 10.	Repeatability of PBBT-reported GVW measurements on the 3-S2 and the 2-axle vehicle (Tests 1 – 4) .....	28
Figure 11.	Repeatability of PBBT-reported $decel_{EQ}$ ( $BF_{TOT}/GVW$ ) for weakly braked vehicles (Tests 1 – 4) .....	29

Figure 12. Strongly braked 2-axle, unladen, dry (Test 5) .....	34
Figure 13. Strongly braked, 1/3 laden 2-axle, dry conditions (Test 6) .....	35
Figure 14. Strongly braked, 2/3 laden 2-axle, dry conditions (Test 7) .....	36
Figure 15. Strongly braked, 2/3 laden 2-axle vehicle, wet conditions (Test 8) .....	37
Figure 16. Strongly braked, unladen 2-axle vehicle, wet conditions (Test 9) .....	38
Figure 17. Repeatability of PBBT-reported BF measurements for axle 2 on the strongly braked 2-axle vehicle (Tests 5 - 9) .....	41
Figure 18. Total Brake Forces as a function of dry and wet PBBT test surface .....	43

### **Tables**

Table 1. Recommended criteria for identification of an unsafe vehicle due to insufficient braking capacity or weak brakes .....	2
Table 2. References used to determine accuracy and applicability of PBBTs .....	4
Table 3. List of test stations .....	5
Table 4. Test matrix of vehicle conditions for PBBT round robin .....	7
Table 5. Acceptable ranges of accuracy for PBBTs .....	13

### **Appendices**

Appendix A. Photographs of the PBBT Round Robin
Appendix B. Reference Data
Appendix C. PBBT Data
Appendix D. Brake Force History Plots
Appendix E. PBBT Individual Axle Load Measurements
Appendix F. Participating PBBT Manufacturers, Vendors & Representatives



# 1. Introduction

## 1.1 Background

In an effort to improve highway safety, the US Department of Transportation, Federal Motor Carrier Safety Administration (FMCSA) is supporting a program for the development, evaluation, and application of Performance-Based Brake Testers (PBBTs) for use on commercial vehicles. A PBBT is a device that can evaluate the braking capabilities of a vehicle in its current condition through a quantitative assessment (i.e. measurement) of brake forces. Some PBBTs can also evaluate the fully laden braking capabilities of an unladen vehicle. A PBBT is of benefit to both the law enforcement and the motor carrier communities because it provides an objective measure of the braking performance of a vehicle. It does so irrespective of the brake type (disk or drum), the energy supply (air, hydraulic, electric, or spring), or the application method (s-cam, wedge, piston, spring, or lever and cable). Examples of PBBTs include roller dynamometers (RDs), flat plate brake testers (FPs), and breakaway torque brake testers (BTTs).

PBBTs have been in common use in Europe for more than 20 years for periodic safety inspections of commercial vehicles (CVs). The PBBTs used in Europe are almost exclusively in-ground RDs, and the European regulations have been developed accordingly. Additionally, European vehicle design regulations require access to certain diagnostic signals that are not available on North American fleets. As a result, European criteria are not generally applicable to the fleet of vehicles operating in North America. The FMCSA-sponsored program has been examining additional types of PBBTs, with a focus on portable models. As such, there is no precedent for guidance on regulations applicable for use of PBBTs in North American law enforcement activities.

New performance-based regulations may be developed which define the criteria by which underbraked vehicles as well as individual weak brakes can be identified using a PBBT. Prior field testing of PBBTs indicated that the applicability of criteria based on

agreement with CVSA<sup>1</sup> inspection results was limited. As such, a universally applicable set of criteria was presented as part of the recent field evaluation research<sup>2</sup>. Any new regulations must be consistent with current performance-based braking safety criteria, i.e. measures of vehicle deceleration, stopping distance, or both. The current criteria<sup>3</sup> are codified in Title 49 of the Code of Federal Regulations, Section 393.52 (49 CFR 393.52).

The PBBT performance-based criterion recommended in the earlier field evaluation research for identification of an underbraked vehicle is based on the ratio of all brake forces available at the wheels ( $BF_{TOT}$ ) to the GVW. This ratio is referred to as the “equivalent deceleration”,  $decel_{EQ}$ . The recommended performance-based criteria for identification of weak brakes included a single low BF with respect to the wheel load (WL) as well as a BF imbalance across a given axle. The performance-based criteria from the earlier field research are reviewed in Table 1.

**Table 1. Recommended criteria for identification of an unsafe vehicle due to insufficient braking capacity or weak brakes.**

Assessment for	Minimum criterion	Result when criterion is not met
Underbraked vehicle	Underbraked if $BF_{TOT} / GVW < 0.4$	Out Of Service
Imbalanced braking on power-unit steer axle	Out of balance if $BF_{min} / BF_{max} < 0.55$	Out Of Service
Defective brake on steer axle wheels	Defective if $BF / WL < 0.25$	Citation
Defective brake on non-steer axle wheels	Defective if $BF / WL < 0.35$	Citation

BF - brake force;  $BF_{TOT}$  - total BF; GVW - gross vehicle weight; WL - wheel load

<sup>1</sup> The Commercial Safety Alliance (CVSA) is the organization responsible for the development and maintenance of the North America Uniform Out-of-Service criteria for heavy trucks and buses: criteria include vehicles, drivers and transport of hazardous materials. Information about the CVSA can be found at (301) 564-1623 or at <http://www.cvsa.org>.

<sup>2</sup> S. J. Shaffer and P. A. Gaydos, "Development, Evaluation and Application of Performance-Based Brake Testing Technologies", FHWA/MC-98/048, April, 1998. The executive summary can be accessed at the following address: [http://www.itsdocs.fhwa.dot.gov/jpodocs/repts\\_te/8mn01!.pdf](http://www.itsdocs.fhwa.dot.gov/jpodocs/repts_te/8mn01!.pdf)

<sup>3</sup> For vehicles over 10,000 lbs. or combination vehicles, a braking force (BF) as a percentage of gross vehicle or combination weight (GVW) of at least 43.5 must be achieved during a stop from 32.2 km/hr (20 mph) on dry pavement. Alternatively, a combination vehicle must be able to stop within 12.2 meters from 32.2 km/hr, or 40 feet from 20 mph.

In addition, functional specifications for PBBTs (e.g. calibration documentation requirements and the minimum required accuracy for PBBTs purchased with funds from the FMCSA's Motor Carrier Safety Assistance Program (MCSAP)) are being developed<sup>4</sup>.

A round robin<sup>5</sup> was conducted in July 1998 at the Vehicle Research and Test Center (VRTC) of the National Highway Traffic Safety Administration (NHTSA).

## 1.2 Objectives

The objective of the round robin was to determine whether or not the current generation of PBBTs could be used for enforcement, i.e. whether or not a vehicle's individual brakes or overall braking capability could be judged accurately and repeatably from one PBBT to another, and whether the results were representative of a vehicle's on-road braking capability (applicability).

## 1.3 Method of Evaluation

The tests were designed to allow the evaluation of the accuracy, the applicability and the repeatability of the measurements of the current generation of PBBTs under variable conditions (e.g. vehicle types, vehicle load, vehicle braking capacity or test surface conditions).

Accuracy addresses the question: "Does the PBBT report the actual forces (e.g. BF's and WLs) being applied within an acceptable tolerance?"

Applicability addresses the question: "Are the forces being applied by the vehicle during the PBBT test representative of those applied during on-road braking from 32.2 km/hr (20 mph)?"

Repeatability addresses the question: "Does the PBBT report the same forces under repeated identical conditions?"

The PBBT results were compared to reference values as shown in Table 2.

---

<sup>4</sup> "Development of Functional Specifications for Performance-Based Brake Testers Used To Inspect Commercial Motor Vehicles", FHWA-1998-3611-1, Federal Register, Vol. 63, No. 108 (June, 1998).

<sup>5</sup> The term "round robin" describes a series of tests in which a single "standard" is used to evaluate the consistency of various test apparatus. In the round robin presented in this report, the "standard", a specific configuration of brake forces and wheel loads on a heavy-duty vehicle, was used to evaluate the candidate PBBTs and their operating protocols.

**Table 2. References used to determine the accuracy, the applicability and the repeatability of PBBTs**

	<b>Measurement</b>	<b>Reference</b>
Accuracy	WL	Calibration using traceable dead weights
	BF	Calibration using traceable loads applied via fixture
		Calibrated torque wheel
Applicability	Decel <sub>EQ</sub>	Average deceleration measured from a 32.2 km/hr (20 mph) road stop
	GVW	Sum of pre-measured axle loads using certified scales
	WL	Pre-measured axle or wheel load using certified scales
	BF <sub>TOT</sub>	Total BFs computed from GVW (certified scales) and average deceleration (on-road stops).
Repeatability	Decel <sub>EQ</sub>	Replicate values reported from repeat tests of same conditions
	GVW	
	WL	
	BF <sub>TOT</sub>	

## 2. Experimental Details

### 2.1 Test Stations

The round robin included nine stations as listed in Table 3. The stations included three portable RDs, two in-ground RDs, one in-ground FP, one portable FP, one portable BTT, and a 32.2 km/hr (20 mph) road stop. The principles of operation of RDs, FPs and BTT are detailed elsewhere<sup>6</sup>. An additional portable RD, which was equipped with some experimental hardware and software, was included in a selected number of tests. The order of the testing was the same as the station number, and was determined by site logistics at the VRTC. Photographs of each of the PBBTs are presented in Appendix A.

**Table 3. List of test stations**

Station No.	Manufacturer/Vendor	Type	Method
1	Hunter	In-Ground	Flat Plate
2	BM/RAI	Portable	Roller Dynamometer
3	VIS	Portable	Roller Dynamometer
4	BM/VRTC	In-Ground	Roller Dynamometer
5a	HEI	Portable	Roller Dynamometer
6	B&G	Portable	Breakaway Torque Tester
7	HEKA	Portable	Flat Plate
8	-	On-Road	32.2 km/hr (20 mph) Road Stop
9	BM/RAI	In-Ground	Roller Dynamometer
5b*	HEI	Portable	Roller Dynamometer

\* Included in selected tests, as time allowed.

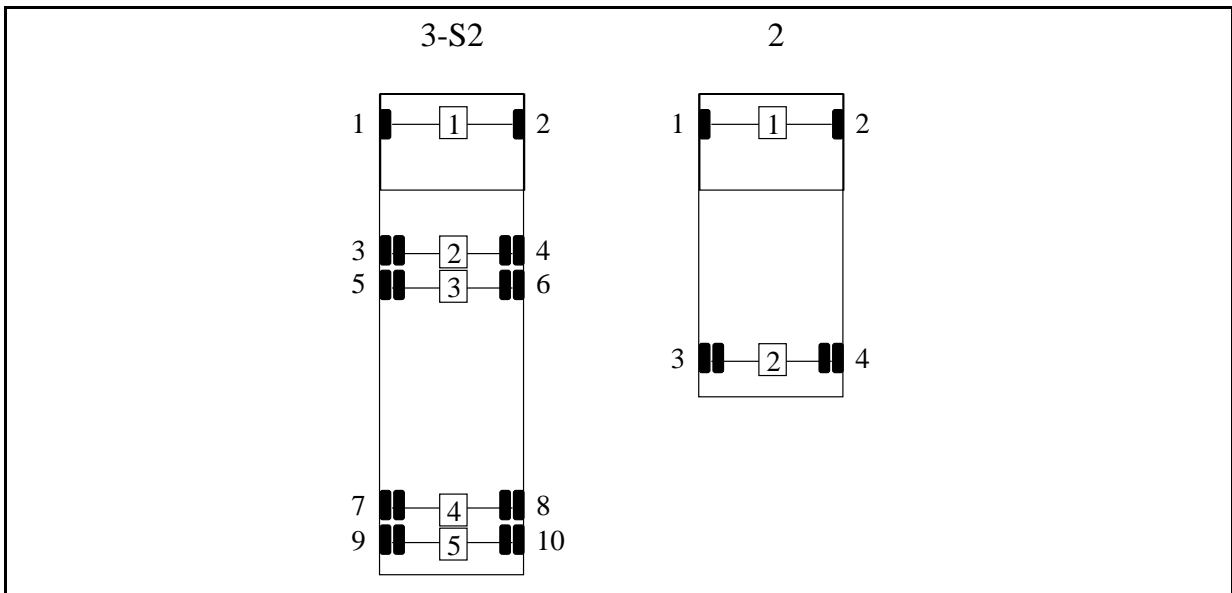
### 2.2 Vehicle Descriptions

Two types of commercial vehicles, with different braking and loading configurations, were prepared. A combination three-axle tractor, two-axle flatbed semi-trailer (3-S2) and a

<sup>6</sup> S.J. Shaffer, & G.H. Alexander, "Evaluation of Performance-Based Brake Testing Technologies", FHWA-MC-96-004, December, 1995.

two-axle flatbed straight truck (2) were selected for the tests as they represent the majority of the axle configurations of commercial vehicles on the road. Each vehicle was tested fully laden and unladen. Both vehicles were initially set up with target brake force to wheel load ratios (BF/WL) on selected wheels, keeping the braking capability of the vehicle as a whole consistent with the performance-based regulation under consideration by the OMCS at the time of the round robin. Additional testing was performed on the 2-axle vehicle in a weakly-braked condition.

The convention used in this report to identify vehicle wheels is shown in Figure 1.



**Figure 1. Identification of wheel numbers on the two test vehicles.**

Both vehicles were instrumented and data were collected at 100 Hz. A fifth-wheel speed sensor was installed on each vehicle, and was used to derive stopping distances and decelerations. In addition, a Labeco on-board computer tied to a switch on the brake pedal was installed on both vehicles to compute stopping distances<sup>7</sup>. An instrumented torque wheel was fitted to wheel number 5 on the 3-S2. Air pressure was monitored on the 3-S2, using transducers at each of the six tractor wheel air chambers and upstream of the trailer distribution valve. The air pressure was controlled on the two-axle vehicle, but not monitored during testing.

<sup>7</sup> The two-axle vehicle experienced some instrumentation difficulties, so data were not always available from both systems.

## 2.3 Test Matrix

The test matrix for the round robin is shown in Table 4. A total of 9 test conditions were run. The testing program had two parts, which are described in more detail below.

**Table 4. Test matrix of vehicle conditions for PBBT round robin**

<b>Part 1:</b>					
<b>Vehicles with Weak Brakes</b>					
Dry conditions only - 3 replicate tests (separate)					
<b>Test No.</b>	<b>1</b>	<b>2</b>	<b>3</b>	<b>4</b>	
<b>Vehicle Type and Loading</b>	3-S2	2-Axle	3-S2	2-Axle	
	Laden		Unladen		
<b>Condition</b>	Dry	Dry	Dry	Dry	
<b>Part 2:</b>					
<b>Vehicles with Fully-Adjusted Strong Brakes</b>					
Dry and wet conditions, 2-axle truck only - 3 replicate tests (consecutive)					
<b>Test No.</b>	<b>5</b>	<b>6</b>	<b>7</b>	<b>8</b>	<b>9</b>
<b>Vehicle Loading</b>	2-Axle	2-Axle	2-Axle	2-Axle	2-Axle
	Unladen	1/3 laden	2/3 laden	2/3 laden	Unladen
<b>Condition</b>	Dry	Dry	Dry	Wet	Wet

### 2.3.1 PART 1 – VEHICLES WITH WEAK BRAKES

In the first part of the testing program (Tests 1-4), three rounds were conducted for each test condition such that, in each round, the vehicles traveled from test station to test station, resulting in three separate replicate tests<sup>8</sup>. In Tests 1-4, the following evaluations were performed on weakly-braked vehicles, under laden and unladen conditions:

- 1) The accuracy and applicability of BF measurements: For the accuracy, the PBBT-measured BFs per wheel were compared to the BFs measured using a calibrated torque wheel. For the applicability, the PBBT-measured total BFs ( $BF_{TOT}$ ) were compared to BFs computed from the 32.2 km/hr (20 mph) on-road stops.

<sup>8</sup> The 3-S2 combination vehicle with weak brakes under empty conditions (Test 3) was not properly set up for the first replication of this test. Recognizing the improper set-up after the first round, several brakes were readjusted. As a consequence, only results from the second and third rounds are utilized for analysis of this condition.

- 2) The accuracy and applicability of WL measurements: For the accuracy, sets of cement blocks of known weight were placed on the PBBT weighing mechanisms and the PBBT results were compared to the known weights. For the applicability, the PBBT-measured axle loads were compared to axles loads obtained using traditional in-ground or portable certified scales.
- 3) The applicability of the equivalent deceleration ( $\text{decel}_{\text{EQ}}$ ): The PBBT measurements were compared to the deceleration achieved during 32.2 km/hr (20 mph) road stops.
- 4) The repeatability of the PBBT measurements: PBBT results from three replicates were compared.

### **2.3.2 PART 2 – VEHICLES WITH FULLY-ADJUSTED STRONG BRAKES**

In the second part of the testing program (Tests 5-9), the brake forces of the two-axle truck were restored to their fully adjusted values, providing braking forces sufficient to lock the wheels in a high demand or panic stop<sup>9</sup>. In this condition, the testing focused on additional factors that could affect the results of the PBBTs, such as the vehicle load (empty or partially laden) or the condition of the PBBT test surface (wet or dry). The accuracy, repeatability and applicability of the WL measurements are not expected to be affected by the level of braking capability or the test surface conditions. Since WL variations are not expected to differ from those discussed in Part 1, the  $\text{decel}_{\text{EQ}}$  and the BFs variations are assumed proportional. Therefore, in Part 2, the following evaluations were conducted on the weakly-braked, 2-axle vehicle:

- 1) The applicability of the equivalent deceleration ( $\text{decel}_{\text{EQ}}$ ): The equivalent deceleration predicted using the PBBT measurements was compared with the deceleration from 32.2 km/hr (20 mph) road stops.
- 2) The repeatability of the BF measurements: PBBT-reported BFs from three replicates were compared.
- 3) The effect of wet test surfaces on the PBBT-reported BFs was evaluated by comparing the maximum BFs reported under both wet and dry conditions.

---

<sup>9</sup> The tests on lightly loaded vehicles were designed to subject the wheels to lockup. If  $\text{BF/WL} > \text{COF}$  (road or PBBT test surface), then the braking force will prevent rolling of the wheel (i.e. the wheel locks up) and skidding will occur.



In Tests 5-9, the three replicate tests were conducted consecutively on each test station, i.e. after the first or second replicate test was completed, the vehicle was backed off the PBBT and subsequently repositioned for further replicate testing<sup>10</sup>.

As an added, but previously unplanned part of the evaluation, calibrations of the PBBTs, both for BF and WL measurements, were carried out for some of the PBBTs as time allowed. Calibration procedures, when available, were also reviewed. These reviews were performed for the benefit of the PBBT participants and the results are not included in this report.

## **2.4 Target Vehicle Set-up**

### **2.4.1 BRAKE FORCES**

The VRTC in-ground RD was used to set up target brake forces on the two test vehicles. The target brake forces were selected in accordance with the tentative criteria for identification of weak brakes (Table 1). As shown in Figure 2, the target BF/WL ratio for one of the steer axle wheels was 0.25. The target BF/WL ratio for one of the non-steer axle wheels was 0.35. The overall vehicle  $BF_{TOT}/GVW$  (equivalent deceleration) target was 0.4. BFs at each wheel were controlled by limiting the control line air pressure with regulators and proportioning valves<sup>11</sup> while the driver imparted full pedal application.

Due to the nature of friction in a sliding contact, a minimum of ten percent variation in brake force is to be expected from one application to another for nominally identical conditions. This fact was used in establishing both the accuracy and the acceptable range of repeatability for PBBT BF measurements.

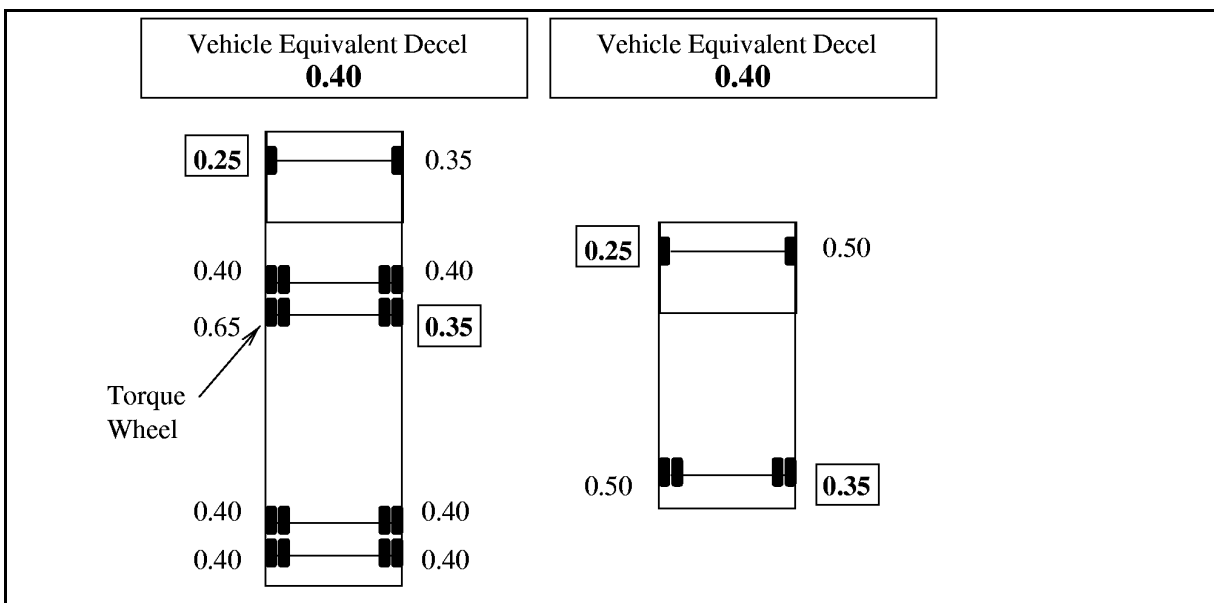
---

<sup>10</sup> In the second part of testing, to prevent rearward movement of the vehicle, the third replicate test on the RDs was to be performed with the front wheels chocked while testing the vehicle's rear wheels. However, due to the slippery epoxy-painted concrete floor and to the steep angle of the chock block, rearward movement of the vehicle at test termination could not be completely prevented on the RDs.

<sup>11</sup> On the 3-S2, regulators were fitted to the tractor wheel air chambers as well as upstream of the trailer distribution valve. On the two-axle vehicle, a single regulator was used to limit the overall pressure, and proportioning valves on each axle controlled the side-to-side BF imbalance.

## 2.4.2 WEIGHTS

For the fully laden cases, the vehicles were loaded with concrete blocks near the legal road limit<sup>12</sup>. The axle load measurements, shown in Table B3 (Appendix B), were used as reference loads to evaluate the applicability of the PBBT's axle load measurements, i.e. to evaluate whether or not the PBBT-reported WLs are representative of the vehicle's WLs when on the ground. Axle and/or wheel loads were measured using certified in-ground platform scales at the Transportation Research Center (TRC) as well as individual certified portable scales provided by the Ohio State Highway Patrol.



**Figure 2. Target brake-force-to-wheel-load ratios for each wheel and for the overall test vehicles for Tests 1-4.**

The actual weight of a vehicle is not expected to vary to the same extent as the brake forces in repeated measurements. However, load distribution on the individual wheels can vary as a result of friction in the suspension components when a vehicle is stopped in position on a platform scale. Variations on the order of 50 to 150 lbs. in the wheel/axle

<sup>12</sup> For the 3-S2, the steer axle was near 12,000 pounds and the drive and trailer axles were near 17,000 pounds each. For the two-axle truck, the steer axle was near 11,500 pounds and the drive axle was 21,000 pounds, resulting in the vehicle's weight slightly exceeding the GVWR. Federal limits on axle weights are codified under Title 23 CFR Part 658.17.

weight measurements of multi-unit or tandem-axle vehicles were observed using certified in-ground scales, resulting in a variation up to 5% for each wheel of a 6,000-lb axle.

The use of portable scales resulted in smaller variations in WL measurements because all wheel loads were measured simultaneously. When available, portable scale weight measurements were used rather than in-ground platform scale weight measurements.

## 3. Results

### 3.1 Vehicles with Weak Brakes (Tests 1-4)

This section investigates the ability of PBBTs to identify weak brakes and underbraked vehicles. All BF and WL data from each test can be found in Appendix C.

The key requirement for use of PBBTs in enforcement is accuracy. Acceptable accuracy of the PBBT results can be documented through a calibration check of the PBBT transducer outputs, compared with known standards. The functional specifications list the required accuracy ( $\pm 2.5$  percent). This method uses direct calibration standards, such as dead weights applied through lever arms of known geometry (for BF calibration) or concrete blocks of known weight (for WL calibration). For accuracy checks using forces and loads applied by the vehicle (i.e. indirect standards), additional factors must be considered. Table 5 lists the acceptable accuracy range when direct and indirect standards are used. When indirect standards are used, a measurement uncertainty or real-life variation is added to the direct standard uncertainty. For example, for the brake force measured using known lever arms and weights (direct standard), the acceptable accuracy range is  $\pm 2.5$  percent. But when a vehicle is used to apply the loads (indirect standard), the geometry of the contact between the wheel and the test surface must be considered. Therefore, the acceptable accuracy ranges using indirect standards are larger than those using direct standards.

**Table 5. Acceptable ranges of accuracy for PBBTs. Acceptable range of applicability and repeatability are also indicated in bold characters.**

Measurement	Direct Standards (%)	Measurement Uncertainty* or Expected Real Life Variations, (%)	Indirect Standards (%)
Brake Force (from Torque Wheel)	± 2.5	FPs: ± 1.8 BTT: ± 3.1 RDs: ± 4.6	FPs: ± 4.3 BTT: ± 5.6 RDs: ± 6.9
Brake Force (from Road Stop)	± 2.5	± 5.0	± <b>7.5**</b>
Wheel Load or GVW	± 2.5	± 0.5	± <b>3.0**</b>
BF/WL or BF <sub>tot</sub> /GVW	± 5.0	± 5.0	± <b>10.0**</b>

\* Differences in torque wheel measurements are due to a “geometry factor” which incorporates the different tire/test surface contact conditions (See Appendix B, page 6).

\*\* Acceptable ranges of applicability are shown in bold.

To use PBBTs to predict braking capabilities of a vehicle on the road, the applicability of PBBT-reported values must be considered in addition to accuracy. Acceptable ranges of applicability are assumed equal to those of accuracy when indirect standards are used (Table 5). However, in some cases, the significance of the deviations between the PBBT-reported value and that of a reference value was assessed using engineering judgement of their safety criticality. Additionally, it is expected that deviations between the predicted  $decel_{EQ}$  and the on-road deceleration can be accounted for through physical or procedural modifications to the PBBT test and/or through development of appropriate scaling factors.

### 3.1.1 BRAKE FORCES – INDIVIDUAL BRAKE FORCE EVALUATION - ACCURACY

On the 3-S2 vehicle, brake torque data were collected during Tests 1 and 3 by a torque wheel installed on wheel number 5. The BFs achieved during the test were calculated by dividing the measured torque by the tire radius.

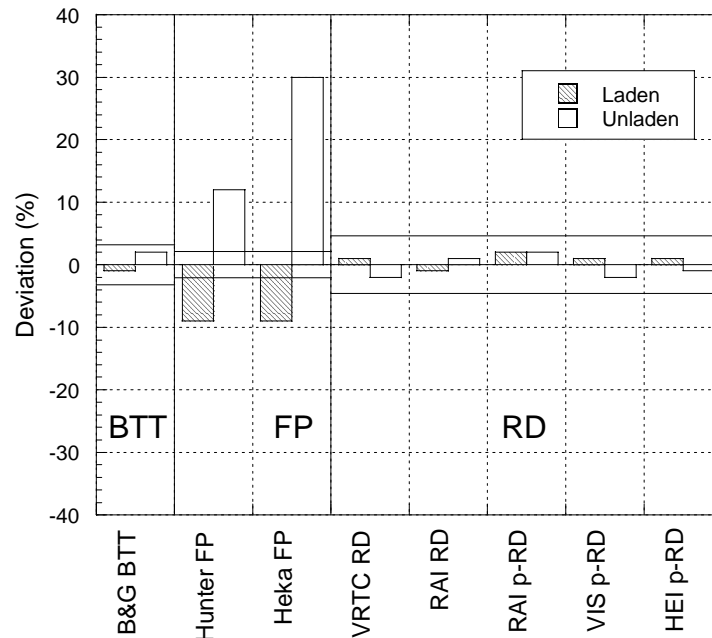
Over the duration of a PBBT test, the BF at a wheel varies with time. The BF value reported by the PBBT depends not only on the proper calibration and accuracy of the PBBT

force sensor, but also on the processing of the data collected by the sensor as a function of time. Since the details of data processing used by each PBBT vendor were not known to the report authors, three distinct methods were used to calculate reference BFs from the torque wheel data. The best match of the three methods was used in the accuracy analysis. In summary, Method 1 reported the maximum BF measured at any time during the test. Method 2 computed and reported the average of the data falling within a given percentage of the maximum. Method 3 reported the BF at the time of test termination. Details are included in Appendix B.

The results for each replicate test of the laden and unladen conditions are tabulated in Appendix B (Table B2). Also, the brake forces measured by the torque wheel are plotted as a function of time in parallel with BFs (where available) measured by PBBTs (Appendix D). These plots are referred to as “time history” plots.

Figure 3 illustrates the percent deviation of PBBT reported BF from the BF computed with the torque wheel data (using the best match from the three methods) for the laden and unladen conditions, respectively. These data are the average from three repeat tests on a single wheel. The proposed FMCSA functional specifications for PBBTs call for  $\pm 2.5$  percent accuracy of BFs for the PBBTs. The total accuracy range incorporates the torque wheel transducer accuracy, the tire radius measurement accuracy, and the error induced on the radius measurement by the varying contact geometries (dependent on the PBBT type), as detailed in Appendix B. The total acceptable range varies from  $\pm 4.3$  to  $\pm 6.9$  percent.

As can be seen in Figure 3, all PBBTs except the flat plates had less than a 3 percent deviation from the torque wheel results, and therefore their accuracy was considered acceptable without further consideration.



**Figure 3. Average deviation of PBBT-reported BF from BF computed from the torque wheel data from wheel 5 of the 3-S2 in the laden and unladen conditions. The algorithm to compute BF from the torque wheel data which gave best fit was used to plot these data. The solid horizontal lines indicate the acceptable ranges for accuracy as listed in Table 5 for indirect standards.**

For the FPs, low BFs were reported in the laden condition and high BFs were reported in the unladen condition. It should be noted that low reported brake forces do not necessarily lead to a safety concern. The deviations in the FP data must result from the effects of dynamic loading, data manipulation and/or algorithm for reporting BFs. Since the algorithm used by Hunter was unknown, but their FP demonstrated good prediction of  $decel_{EQ}$  (Section 3.1.3), the significance of the 10 percent deviation from the reference BF values is not considered to be a safety issue or of critical significance. No time history data was available from the HEKA FP unit. As such, since deviations up to 30% were observed, this unit would not be considered acceptable for use in enforcement and further evaluation is warranted after appropriate modifications are made by the vendor.

The shape of the time history plots reported by the PBBT vendors appeared to match the data obtained from the torque wheel (Appendix D). The slight variations between the PBBT-reported brake forces and those calculated from the torque wheel data must result

from differing algorithms. As such, it is recommended that for each type of PBBT, a common procedure be developed, adopted and documented. The algorithm for reporting the BF should include filtering to avoid any problems resulting from anomalous spikes. In doing so, assuming the unit is correctly calibrated, the reported BF should be PBBT-vendor independent.

### **3.1.2 BRAKE FORCES – OVERALL VEHICLE BRAKE FORCE EVALUATION - APPLICABILITY**

In this section, we examine the applicability of the PBBT-reported BFs through comparison with the total BF produced by the vehicle during a 32.2 km/hr (20 mph) on-road stop. For the weakly braked vehicles, it was assumed that no wheels were skidding<sup>13</sup> during the stops and thus that the maximum available brake forces were transmitted to the ground during the stop. As such, the total brake forces were computed using the equation:

$$F = Ma,$$

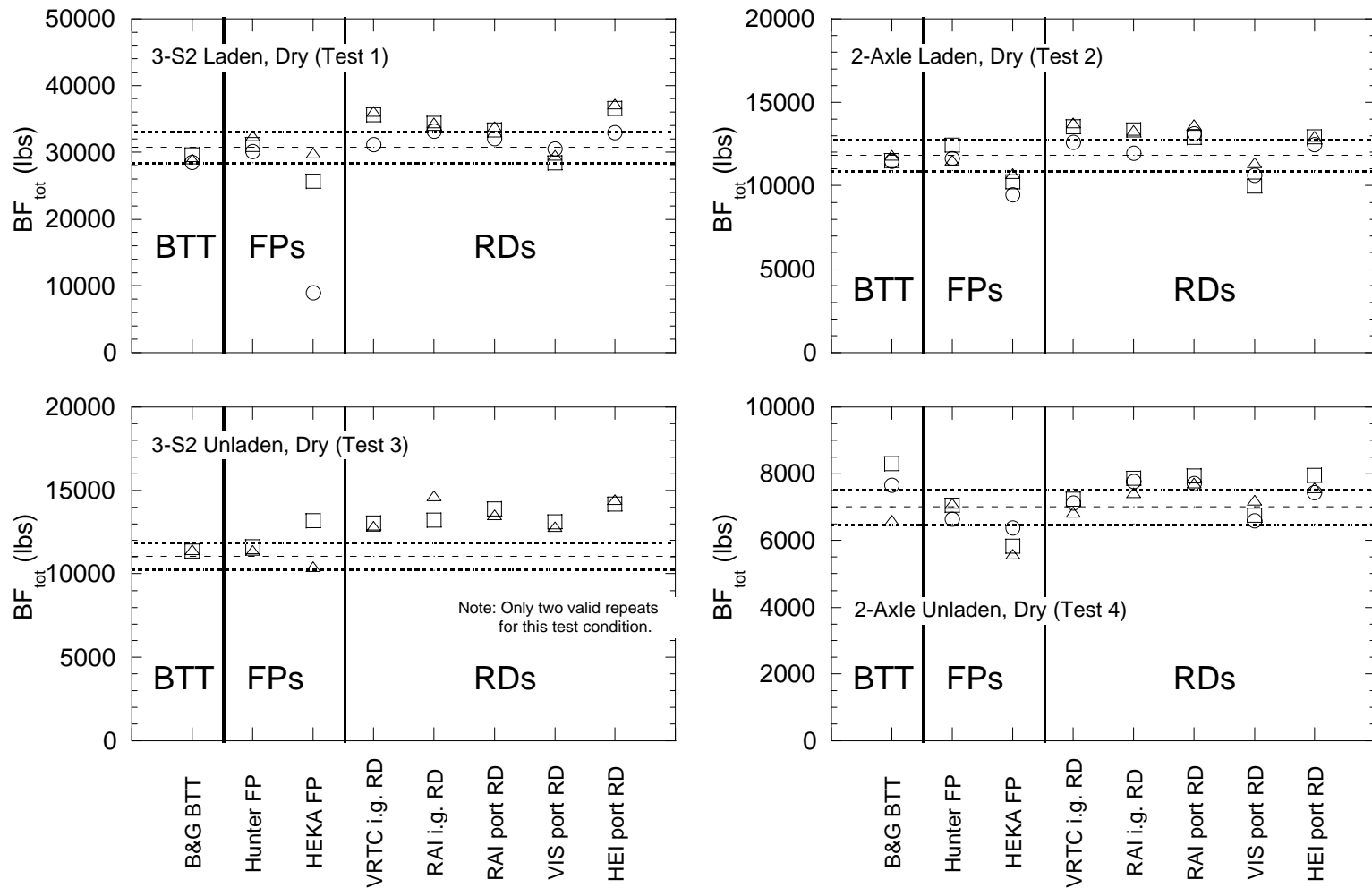
where F is the overall vehicle brake force, M is the vehicle mass (in this case, GVW was used), and a is the average deceleration over the course of the stop. The GVW was measured with certified scales prior to the test and the average deceleration was computed using a linear regression of the slope of the velocity versus time data from the 5<sup>th</sup> wheel data. (See Appendix B for details.) These values were considered the reference for applicability. The BF<sub>TOT</sub> for the PBBT was simply the sum of the individual BFs measured on an axle-by-axle basis.

Figure 4 shows the PBBT-reported BF<sub>TOT</sub> for each of the replicate tests for the weakly braked vehicles. The total vehicle BF deduced from the 32.2 km/hr (20 mph) stops is shown, along with the acceptable range of applicability (Table 5).

---

<sup>13</sup> There may have been some skidding of the most strongly braked wheel (number 5 on the 3-S2 and number 2 on the 2-axle), but this could not be confirmed. Individual wheel speed data were not available from the tests.





**Figure 4.  $BF_{TOT}$  for weakly braked vehicles (Tests 1 - 4).**

Data for replicate 1 (○), replicate 2 (□) and replicate 3 (△) are plotted. The upper and lower dashed lines in the plots show the acceptable range of applicability ( $\pm 7.5\%$ , as listed in Table 5). The middle line represents the reference  $BF$  computed from the reference  $GVW$  (measured with certified scales) and the average deceleration from 32.2 km/hr (20 mph) on-road stops. If PBBT transducers have acceptable accuracy, PBBT or procedural modifications will be required to account for deviations beyond the acceptable range of applicability.

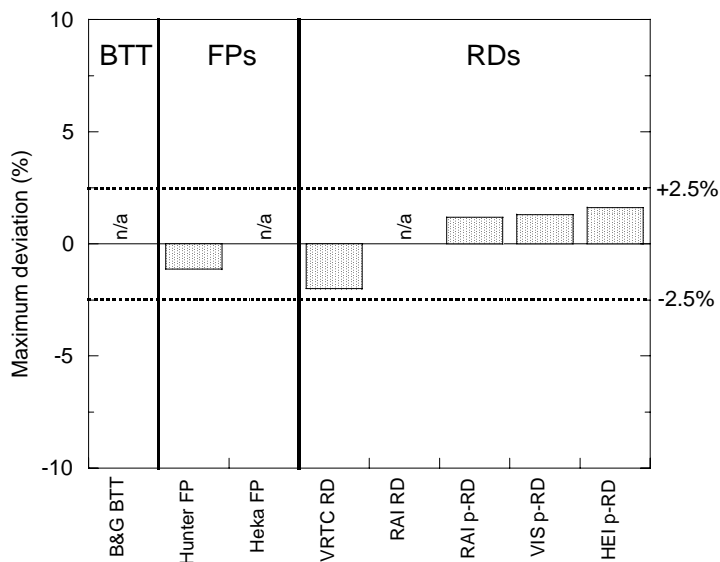
The breakaway torque brake tester (BTT) had acceptable applicability in reporting  $BF_{TOT}$  for weakly braked vehicles for all tests except Test 4, the empty 2-axle, in which two of the three measurements were higher than those computed from on-road stop. As shown in Appendix Table C4, the measured BFs for the strongly braked wheels (numbers 2 and 3) were high. These wheels may have been locked during the road stop, thus limiting the ratio of BF to WL to the road COF. In contrast, the BTT does not have a COF limit since the wheel can not slip in the grips. Torque wheel or wheel speed data were not available to confirm whether or not wheel lock-up occurred. A procedural modification, in which the maximum BF/WL ratio for strong brakes is limited to an assumed maximum road COF value, may have to be invoked in some cases for use in enforcement, so that the BTT does not report BFs higher than those which can be achieved on the road.

The flat plate brake testers (FPs) were split in their applicability in reporting  $BF_{TOT}$  for weakly braked vehicles. The applicability of the Hunter FP was acceptable in all cases. The HEKA exhibited erratic behavior, with only one repeat from each test near the acceptable range. The other repeats showed wide scatter, mostly due to low reported  $BF_{TOT}$ . Since the deviations were not systematic, it was not possible to isolate the cause, nor make recommendations for correction. It was most likely due to the handling of the dynamic data and the algorithms used to compute BFs.

Four of the five roller dynamometers (RDs) showed either acceptable applicability for reporting  $BF_{TOT}$ , or slightly higher values than those measured during road stops. This was clearly seen in Test 3 (unladen 3-S2). Since none of the roller surfaces had a COF higher than that expected for the road, the discrepancy was likely due to either geometric effects from the tire/roller contact patch, or to low speed of the rollers (<2 km/hr or <1.2 mph, for portable RDs) compared to 32.2 km/hr (20 mph) for the vehicle stops. The brake force generated can be higher at low speeds. The development of a scaling factor to account for the speed or geometry dependence may be required for use in enforcement. In contrast, the VIS RD showed somewhat lower  $BF_{TOT}$  than the other RDs. Since the individual torque wheel calibration check did not indicate this systematic difference (Fig. 3), it is suspected that a possible early test termination caused by the stronger brake, or a lower, and thus limiting, roller COF may have been the cause. Meeting the functional performance specifications and use of common test termination and data reduction procedures should adequately address these issues in the future.

### 3.1.3 WHEEL LOADS – INDIVIDUAL WHEEL LOAD EVALUATION - ACCURACY

As shown in Figure 5, acceptable accuracy of the wheel load measurements was observed for all PBBTs for which data were available. Data are included in Appendices B and C. The calibration was performed for the HEKA FP, but the data were not provided for publication. However, it is recollected that the weight calibration was acceptable. Weight calibration of the BTT was not performed due to minor damage to the hydraulic system as the PBBT was moved to get access to the concrete blocks. Similarly, the concrete blocks could not be transported to the off-site RAI in-ground RD, so an electronic shunt-calibration was performed instead, and results were accurate within 2.5%. Acceptable calibrations and documentation of the ability to meet the functional specifications for weighing accuracy will be required as part of compliance testing for use of all PBBTs for enforcement.

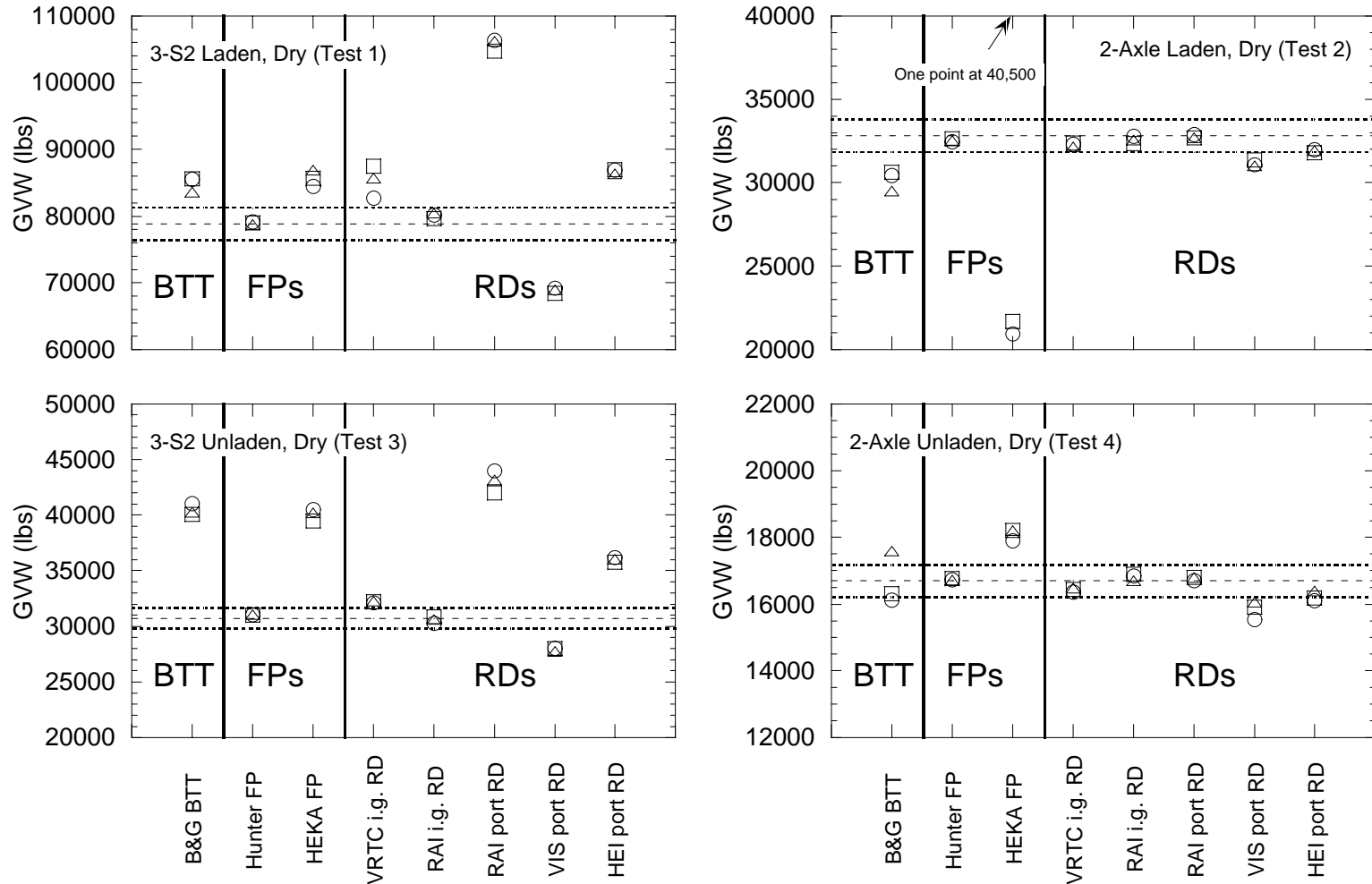


**Figure 5. Maximum deviation of PBBT reported WL from series of applied loads using concrete blocks of known weight. The dashed lines show the acceptable range of accuracy as listed in the PBBT functional specifications and in Table 5.**

### **3.1.4 WHEEL LOADS – OVERALL VEHICLE (GVW) EVALUATION - APPLICABILITY**

The applicability of the PBBT-reported GVW measurements was assessed by comparing the GVW obtained using certified portable scales (in which the entire vehicle weight was measured at once) to the sum of the wheel (or axle) weights reported by the PBBTs. Results are shown in Figure 6 and revealed that, prior to the use of PBBTs for enforcement, procedural or physical modifications will be required, because only the Hunter FP and the RAI in-ground RD had acceptable deviations (Table 5) from the known GVW for all four test conditions. In general, GVW results were more acceptable for the 2-axle vehicle than for the 3-S2 vehicle. Systematic deviations were only observed for the VIS portable RD, which reported low GVWs in each test and the HEKA FP, which reported high GVWs except for Test 2. In Test 2, software problems for the HEKA lead to zero values for some of the axles. As such, the applicability for these two PBBTs was expected to be correctable through appropriate modifications by the PBBT manufacturers.

As shown in Tests 1 and 3, the overall applicability of PBBT-reported GVW for the 3-S2 was questionable. With the exceptions of the Hunter FP and RAI in-ground RD listed above, some PBBTs reported GVWs which were up to 40 percent higher than the reference vehicle weight. Appendix Figure E2 shows that the weight of axles 2 and 4, the leading axles for the tandem set were measured high. Specific procedures will be required when using PBBT-measured GVWs for enforcement. For example, use of modified ramps is expected to resolve this problem. Alternatively, the entry of remotely measured axle weights or criteria for brake forces which do not depend on weight may be required.

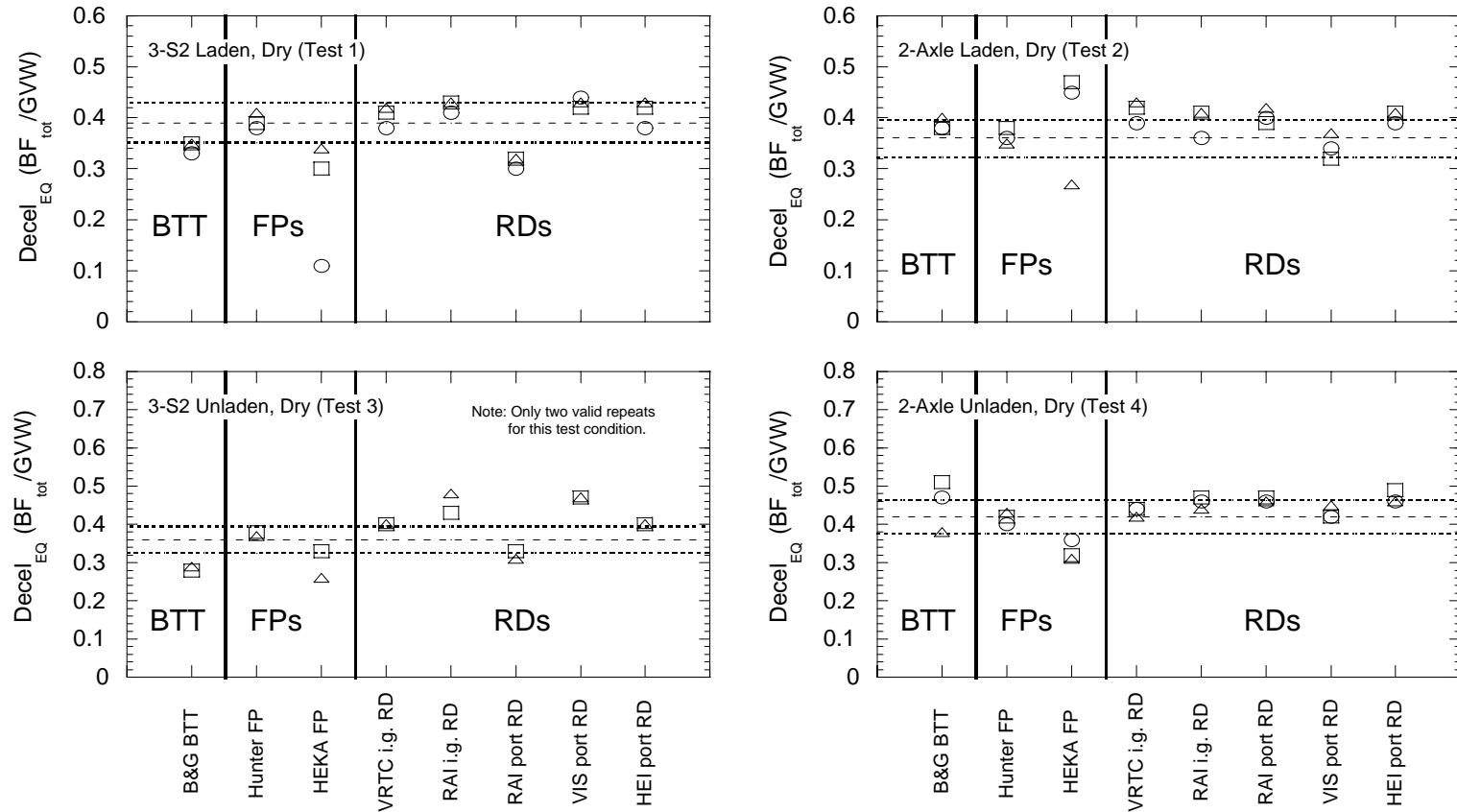


**Figure 6. GVW for weakly braked vehicles (Tests 1 - 4).**

**Data for replicate 1 (○), replicate 2 (□) and replicate 3 (△) are plotted. The upper and lower dashed lines show the acceptable range of applicability (± 3 %, as listed in Table 5). The middle line represents the reference GVW (measured with certified scales). If PBBT transducers have acceptable accuracy, PBBT or procedural modifications will be required to account for deviations beyond the acceptable range of applicability.**

### 3.1.5 DECEL<sub>EQ</sub> – OVERALL VEHICLE EVALUATION - APPLICABILITY

No direct standards could be used to evaluate the accuracy of the decel<sub>EQ</sub> measurements. As such, the PBBT-reported decel<sub>EQ</sub> was compared to the on-road deceleration of the vehicle (indirect standard). By this method, the applicability of the PBBT to predict the 32.2 km/hr (20 mph) vehicle deceleration was evaluated. Results are shown in Figure 7. The Hunter FP results were acceptable in all tests. The results of the HEKA FP indicate that it may require additional development. Although there was some scatter, in general, the results indicate that most of the remaining PBBTs predicted the on-road deceleration very nearly within the bands of acceptability. Most of the deviations could be attributed to the GVW measurements as discussed in Section 3.1.4, and thus can be rectified with implementation of applicable procedures.



**Figure 7.  $Decel_{EQ} (BF_{TOT}/GVW)$  for weakly braked vehicles (Tests 1 - 4).**

**Data for replicate 1 (○), replicate 2 (□) and replicate 3 (△) are plotted. The upper and lower dashed lines show the acceptable range of applicability ( $\pm 10\%$ , as listed in Table 5). The middle line represents the average deceleration from 32.2 km/hr (20 mph) on-road stops. If PBBT transducers have acceptable accuracy, PBBT or procedural modifications will be required to account for deviations beyond the acceptable range of applicability.**

### **3.1.6 REPEATABILITY**

In a manner identical to that used to develop the acceptable ranges for accuracy, the acceptable ranges for repeatability (ARR) were established (Table 5). These combined two uncertainty factors (as described in Appendix B), the acceptable range of accuracy listed in the proposed FMCSA functional performance specifications for PBBTs, and the “real-life” expected variations for brake forces and weights.

The acceptable ranges for repeatability are shown as error bars about the average of the minimum and maximum values from the replicate tests in Figures 8 through 11, in which the repeatability of BF measurements for individual weak brakes (Figures 8 and 9), overall GVW (Figure 10), and  $\text{decel}_{\text{EQ}}$  (Figure 11) are plotted. The acceptable ranges for repeatability are:  $\pm 7.5\%$ ,  $\pm 3\%$  and  $\pm 10\%$ , respectively.

In summary, approximately 93 percent of all measurements were within the ARRs (see Figures 8 through 11). The tests for which results were outside the ARRs were examined in detail. The deviations could be attributed to: operator error, variations in driver brake application, erroneous test results (e.g. HEKA, replicate 1, Test 1 in Table C1) or premature test termination. As such, all PBBTs could be considered acceptable after implementation of appropriate modifications or procedures to recognize and correct these erratic measurements.

#### **3.1.6.1 Repeatability for individual weak brake BFs**

The weak brakes were located on wheels 1 and 6 on the 3-S2, and wheels 1 and 4 on the two-axle straight truck (Figure 2). The BF repeatability results are shown in Figures 8 and 9.

Overall, the repeatability for identification of individual weak brakes was very good, with acceptability in 90 percent of the 192 test runs. Some variability in repeatability could be attributed to the vehicle brakes themselves. In particular, note that for wheel 6 for Test 1, a lower brake force was observed for replicate 1 for all PBBTs. This was also observed (to a lesser extent) for wheel 1. The vehicle brakes may not have been fully conditioned before the first test round and residual moisture from the previous night may have lowered the available BFs. Therefore, any deviation from the ARR due solely to BF values from the first replicate of the first test for wheels 1 and 6 should be discounted.



In the few other cases where the variations were significant, the sources of the variability were identified, and future corrective actions will be taken. These consisted of tests in which low BF was attributed to operator error (BTT), prematurely terminated tests, possible lift-off at wheel lock up<sup>13</sup> (RDs), or variability in driver brake application (both FPs).

### **3.1.6.2 Repeatability for overall GVW**

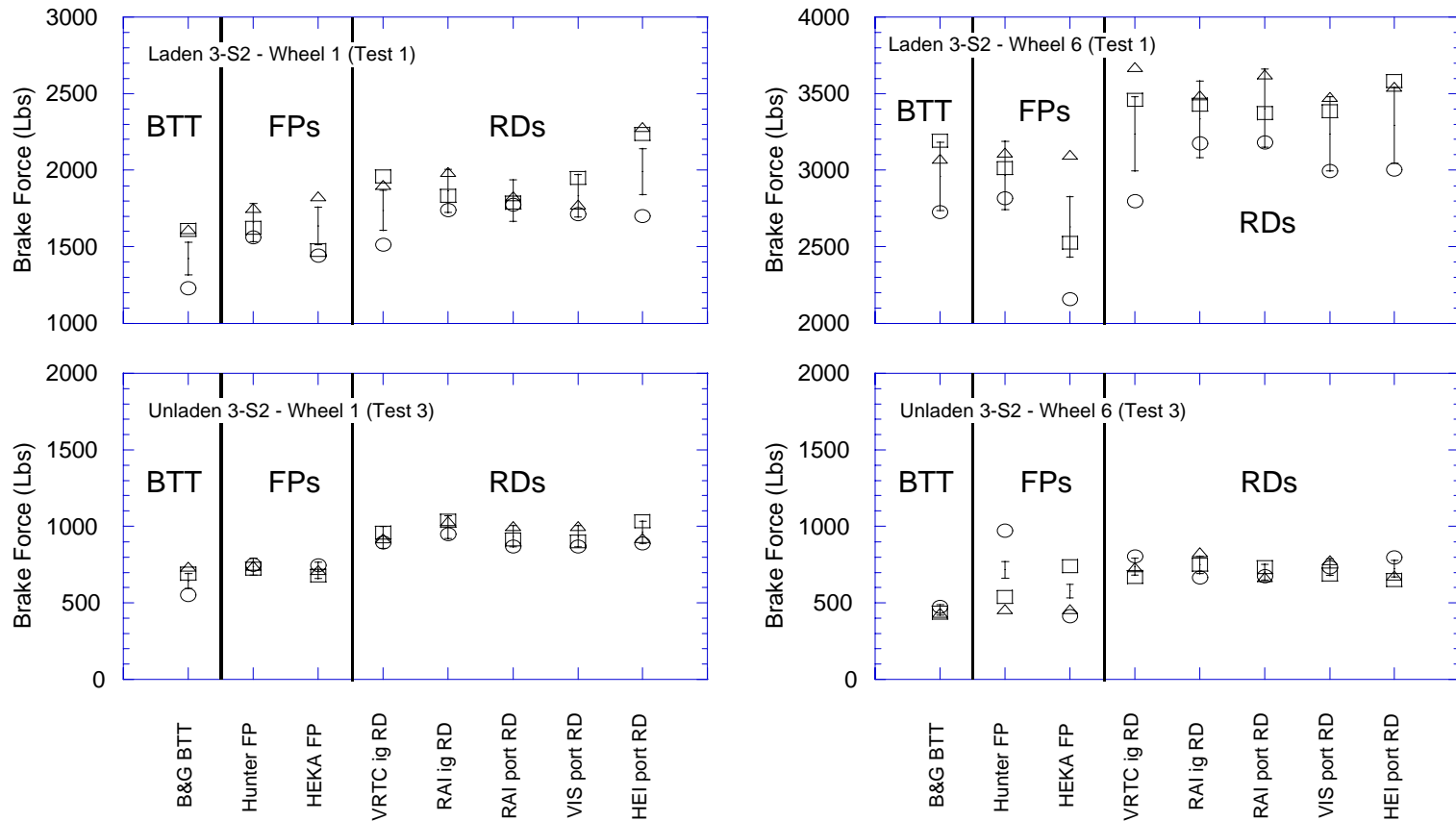
The results for the repeatability assessment of GVW for Tests 1 through 4 are shown in Figure 10. Although it was suspected that the particular suspension and the axle geometry of the 3-S2 led to high reported-GVW values for several of the PBBTs, the repeatability for all PBBTs was excellent. 98 percent of 96 measurements were within the ARR. Replicate 3 of Test 4 (unladen 2-axle) was slightly high for the BTT, with the GVW just beyond the  $\pm 3$  percent ARR. The HEKA showed significant variability on all replicates of Test 2 (laden 2-axle). The extreme high and low reported values most likely resulted from software problems.

### **3.1.6.3 Repeatability for overall vehicle deceleration**

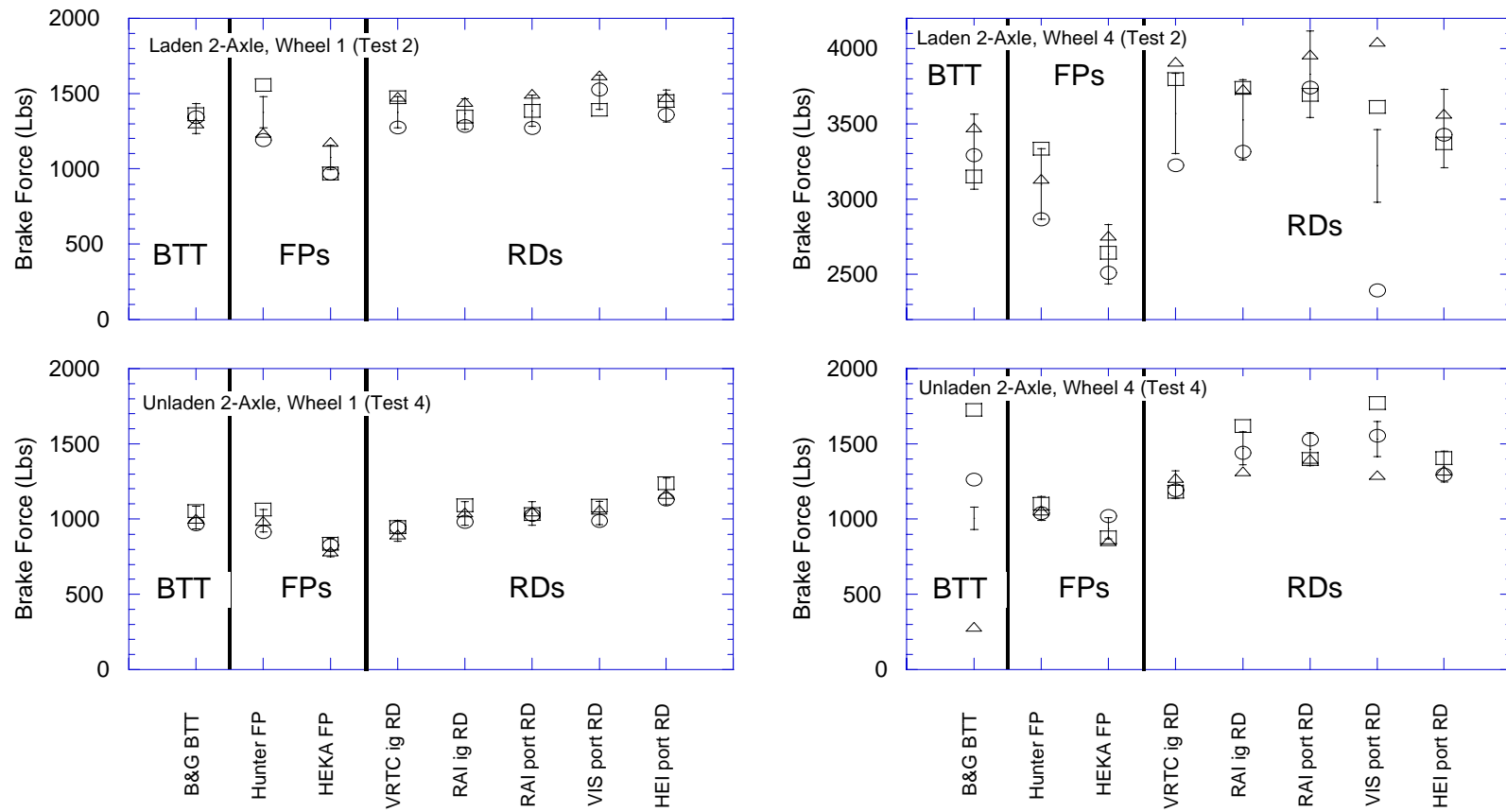
The repeatability for reported values of overall vehicle equivalent deceleration is shown in Figure 11. The repeatability was acceptable in 95 percent of the 96 test runs. The exceptions included both laden vehicles and the unladen 3-S2 for the HEKA FP, and the unladen 2-axle for the B&G BTT. The low repeatability reported by the HEKA was due to apparent software problems resulting in several zero values and double values being reported. The B&G low repeatability was due to an erratic low BF on one wheel in a single test. This appeared to be due to an error in the transfer of the data to the file used in this report. Since these cases appear correctable, the repeatability for overall vehicle deceleration for all PBBTs was considered acceptable.

---

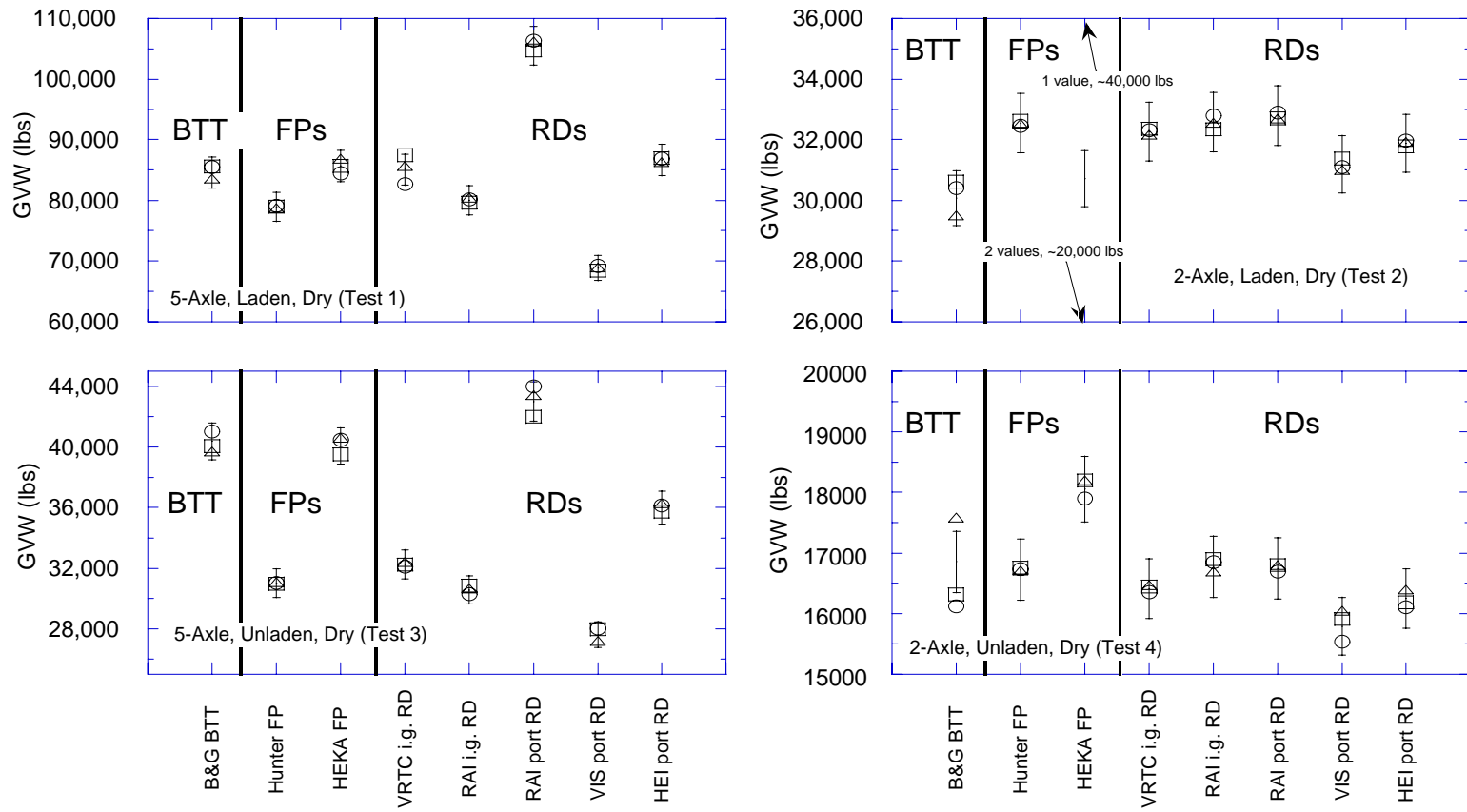
<sup>13</sup> An analysis of the lift-off phenomenon, which is more prominent on the rear axle of 2-axle vehicles, is presented in SAE paper 982829, "Understanding the Portable Roller Dynamometer", S.J. Shaffer and J.W. Kannel.



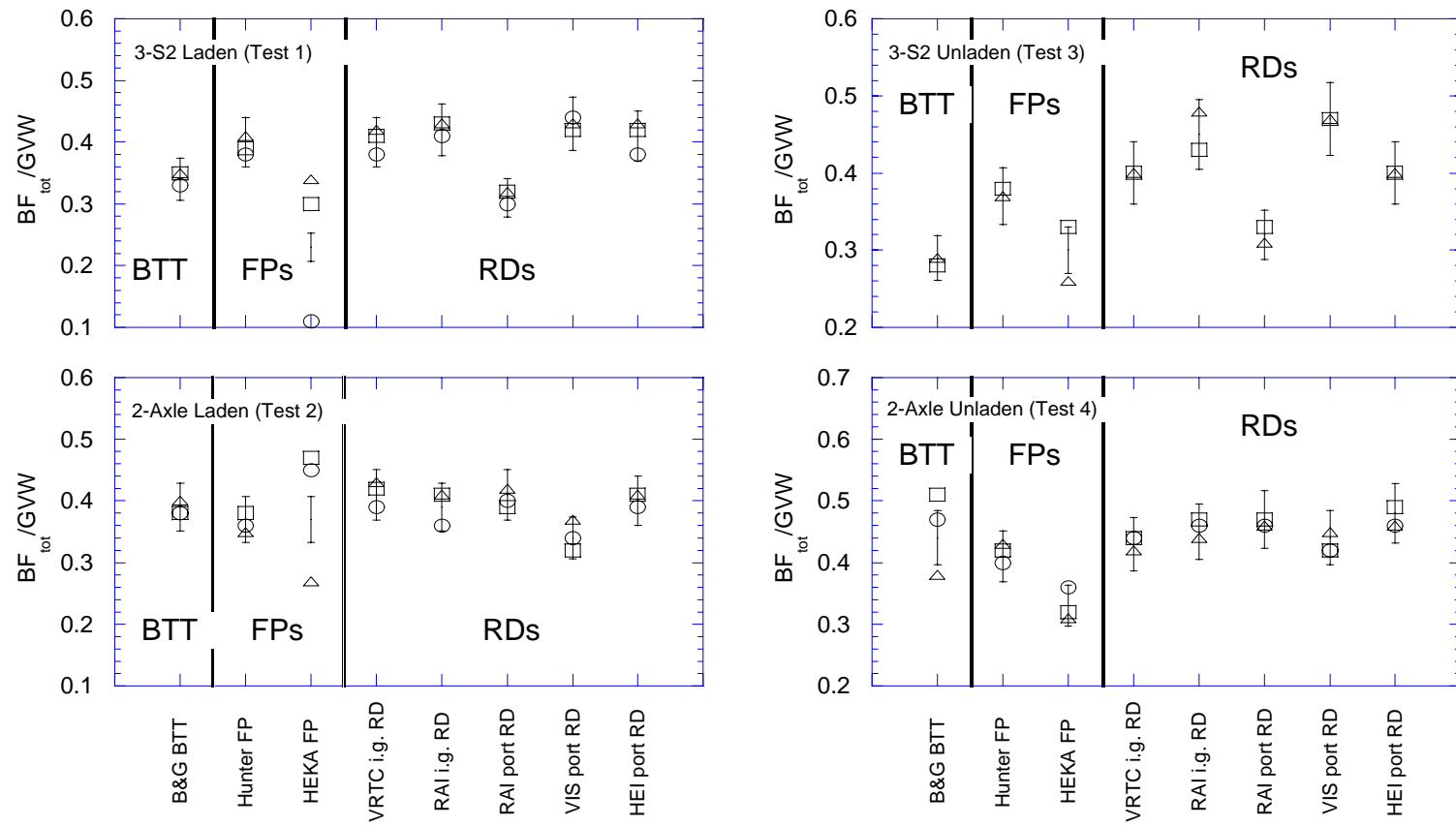
**Figure 8. Repeatability of PBBT-reported BF measurements for weak brakes on the 3-S2 vehicle (Tests 1 and 3). Data for replicate 1 (○), replicate 2 (□) and replicate 3 (△) are plotted. The error bars represent the acceptable repeatability range for BF ( $\pm 7.5\%$ , as listed in Table 5). All PBBTs showed lower BF for Test 1, replicate 1, possibly as a result of residual moisture from the previous night. Any variation due to BF values from Test 1, replicate 1, should be discounted.**



**Figure 9. Repeatability of PBBT-reported BF measurements for weak brakes on the 2-axle vehicle (Tests 2 and 4). Data for replicate 1 (○), replicate 2 (□) and replicate 3 (△) are plotted. The error bars represent the acceptable repeatability range for BF ( $\pm 7.5\%$ , as listed in Table 5).**



**Figure 10. Repeatability of PBBT-reported GVW measurements on the 3-S2 and the 2-axle vehicles (Tests 1 - 4). Data for replicate 1 (○), replicate 2 (□) and replicate 3 (△) are plotted. The error bars represent the acceptable repeatability range for GVW (± 3 %, as listed in Table 5).**



**Figure 11. Repeatability of PBBT-reported  $decel_{EQ}$  ( $BF_{tot}/GVW$ ) for weakly braked vehicles (Tests 1 - 4). Data for replicate 1 (○), replicate 2 (□) and replicate 3 (△) are plotted. The error bars represent the acceptable repeatability range for  $decel_{EQ}$  ( $\pm 10\%$ , as listed in Table 5).**

## 3.2 Vehicles with Fully-Adjusted, Strong Brakes (Tests 5-9)

This section investigates the ability of PBBTs to quantify strong brakes (i.e. high BF/WL ratios) as well as whether the BF measurements are affected by specific PBBT characteristics. Since variations in reported BF values affect predictions of vehicle on-road decelerations, it is important that their origin and magnitude are understood and documented. Such variations may have to be accounted for in enforcement activities.

A strongly braked vehicle was used in this second part of the round robin. The available brake force, i.e. the BF which the vehicle can transmit to the ground (or to the PBBT test surface) can be limited by both the load on a wheel, and by the traction between the tire and the road (or test surface). According to the equation  $F = \mu N$ , the maximum force (F) that can be transmitted before slip occurs is equal to the wheel load (N) times the traction coefficient ( $\mu$  or COF). As such, variations in BF measurements were investigated in various loading and test surface conditions. The test surface traction was modified through the use of water.

The accuracy of the PBBT results for BF and WL measurements was investigated in the first part of the round robin. For the analyses conducted for the second part, it was assumed that the WL measurements were not affected by the level of braking capability or by the test surface conditions. This assumption was confirmed by a similar level of accuracy, applicability and repeatability of the WLs for the 2-axle truck in Part 1 (Figures 5, 6 and 10) and Part 2 (Figures 12-16). As such, variations in  $decel_{EQ}$  observed in Part 2 can be directly attributed to variations in PBBT-reported  $BF_{TOT}$ . Therefore, this section focuses on the PBBT-reported brake forces.

### 3.2.1 APPLICABILITY OF PREDICTED $DECEL_{EQ}$ AND $BF_{TOT}$

The data from Tests 5 through 9, the strongly-braked 2-axle vehicle, were used in the evaluations in this section. For lightly loaded axles, or low traction test surfaces, the full braking capability of the vehicle may not always be measured by a PBBT. In most cases, the coefficient of friction (COF) between the tire and the test surface dictates the upper limit for BF measurements which, in turn, dictates the upper limit for  $decel_{EQ}$ .

Limitations on measured BF will not necessarily result in a safety hazard. A BF reported low due to low surface traction of the test surface will at least provide a minimum level of braking capability. Additional braking capacity may be available. On the other hand, the measurement of additional (reserve) BF beyond that dictated by the wheel load and the expected road/tire COF can in fact be beneficial. Knowledge of additional BF capacity can be used to determine adequate braking capability under heavier loading conditions, and may be used to define the vehicle's load limit for safe braking. However, at this time, the recommended performance-based regulations (see Table 1 in Section 1.1) are applicable to a vehicle under its current loading condition only.

The functional specifications under development for PBBTs call for a COF of at least 0.6 between the test surface and a standard tire to simulate road conditions. Variations from one PBBT to another observed during this portion of the test program do not necessarily indicate a problem with their use in enforcement. For example, a PBBT whose test surface has higher traction than the road (high traction gripper pads, FP grates and certain RD roller surfaces) has the capability of measuring BFs higher than the BFs achieved by the vehicle on the road. As long as the variation in the reported BF is known to result in a higher BF than the vehicle can achieve in a 32.2 km/hr (20 mph) stop, no safety concern exists. In such cases, applicability to vehicle on-road service conditions can be realized if proper account is taken of the ratio between the test surface traction and the road surface traction. The BTT presents a clear example of devices for which measured BFs are expected to differ from those achieved in a 32.2 km/hr (20 mph) road stop. Since the wheel typically can not slip in the gripping mechanism, the brake force measured by the BTT is independent of both wheel load and surface traction and is limited only by the method used for test termination.

The BF results for the strongly braked 2-axle vehicle (Tests 5 through 9) are presented in Figures 12 through 16<sup>15</sup>.

---

<sup>15</sup> Stopping tests were not run for Test 9, the strongly braked, empty two-axle vehicle on wet pavement. Since the BF/WL ratio was greater than the expected road/tire COF, skidding was expected to occur, and potential hazards would be incurred. In this case, a 0.5g deceleration was selected as the reference for comparisons to the PBBT results. The rationalization for this choice is as follows. The COF for skidding under dry conditions was assumed to be in the 0.6 to 0.63 range, equal to the measured deceleration of the strongly braked, empty two-axle vehicle on dry pavement. This range is consistent with the COF for a skidding tire being about 80 percent of that for a rolling tire (the tire/pavement COF for rolling is usually in the 0.75 to 0.8 range for truck tires). A further decrease in COF is expected for wet conditions. In the absence of any published studies on the decrease in COF under wet rolling conditions, 20 percent below the dry skidding case was assumed for the wet skidding case, i.e. 0.5g, in parallel to the observed reduction in COF found under rolling conditions (SAE 962153). However definitive conclusions should not be made using this assumption.

For Test 5, in the unladen, dry condition (Figure 12):

- 1) 7 of the 8 PBBTs predicted at least the  $BF_{REF}^{16}$ , and the on-road deceleration.
- 2) The VIS reported low  $BF_{TOT}$ , as a result of the left side roller (Appendix C).
- 3) The BTT and the FPs all predicted  $BF_{TOT}$  higher than those of the RDs, likely as a result of surfaces with higher traction.

For Test 6, in the 1/3 laden, dry condition (Figure 13):

- 1) 7 of the 8 PBBTs predicted at least the  $BF_{REF}$ , and the on-road deceleration.
- 2) Both FPs exhibited high scatter in their BF values.
- 3) The VIS reported low  $BF_{TOT}$ , as a result of the left side roller (Appendix C).

For Test 7, in the 2/3 laden, dry condition (Figure 14):

- 1) Only the Hunter FP predicted at least the  $BF_{REF}$ , and the on-road deceleration (2 of 3 replicates).
- 2) The BTT<sup>17</sup> and all RDs (except the VIS) predicted decelerations only slightly low.
- 3) Both FPs exhibited high scatter in their BF values.
- 4) The VIS reported low BFs, as a result of the left side roller (Appendix C).

For Test 8, in the 2/3 laden, wet condition (Figure 15):

- 1) 3 of the 8 PBBTs predicted at least the  $BF_{REF}$ , and the on-road deceleration.
- 2) The Hunter FP and the HEI experimental RD (RD2) exhibited higher scatter in the BF values.
- 3) The BTT and all RDs (except the RAI portable and the experimental HEI) predicted low  $decel_{EQ}$  as a result of low BFs. This effect was most pronounced for the VRTC in ground, the VIS RD and the HEI RD. Again, the VIS reported low BFs for the left side wheels.

---

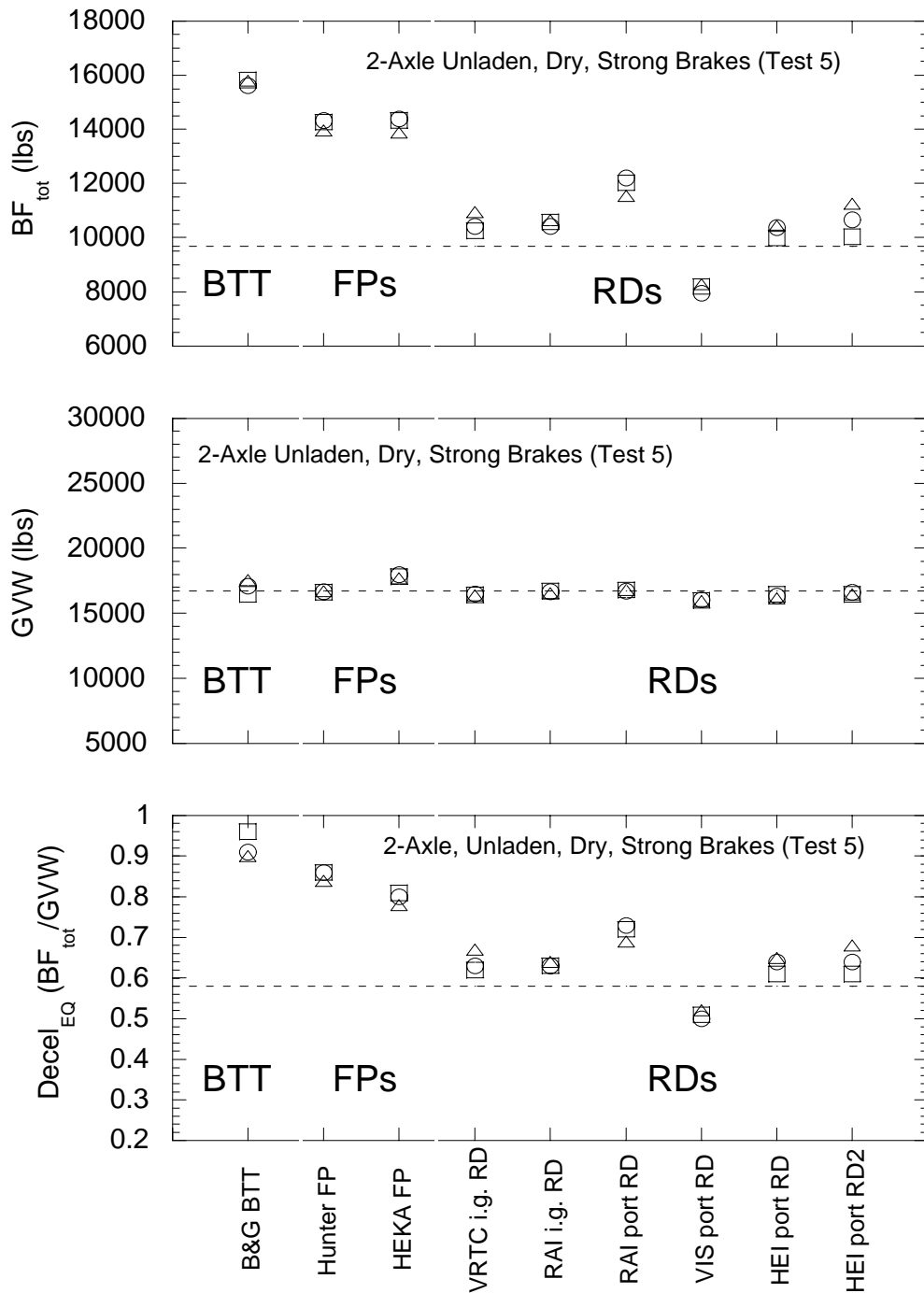
<sup>16</sup> Recall that  $BF_{REF}$  is the total BF calculated from the road stop data, using the average deceleration times the GVW.

<sup>17</sup> The BTT was set up intentionally to terminate the test if the BF on a wheel reached one half of the GAWR. It was observed that the total BF measured for all conditions of Tests 5 through 9 was the same.



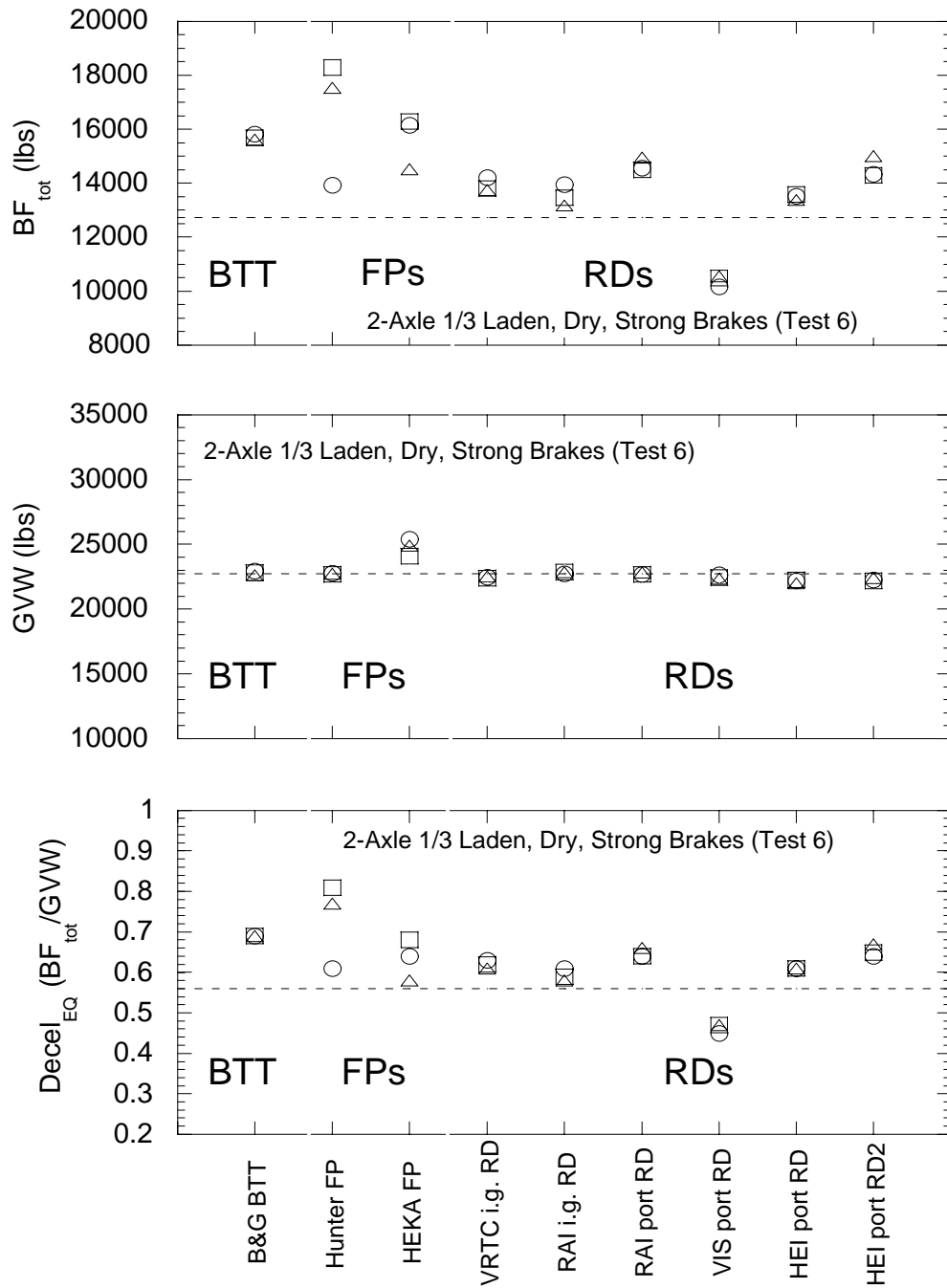
For Test 9, in the empty, wet condition (Figure 16):

- 1) 6 of the 8 PBBTs predicted at least the  $BF_{REF}$ , and the on-road deceleration.
- 2) The Hunter FP and the HEI experimental RD (RD2) exhibited higher scatter in BF values.
- 3) The VIS RD and the HEI RD predicted low  $decel_{EQ}$  as a result of low BFs. The VIS reported low BFs for the left side wheels (Appendix C).
- 4) The BTT, the HEKA FP, the RAI portable RD and the HEI experimental RD (RD2) measured high BF as a result of high test surface traction.

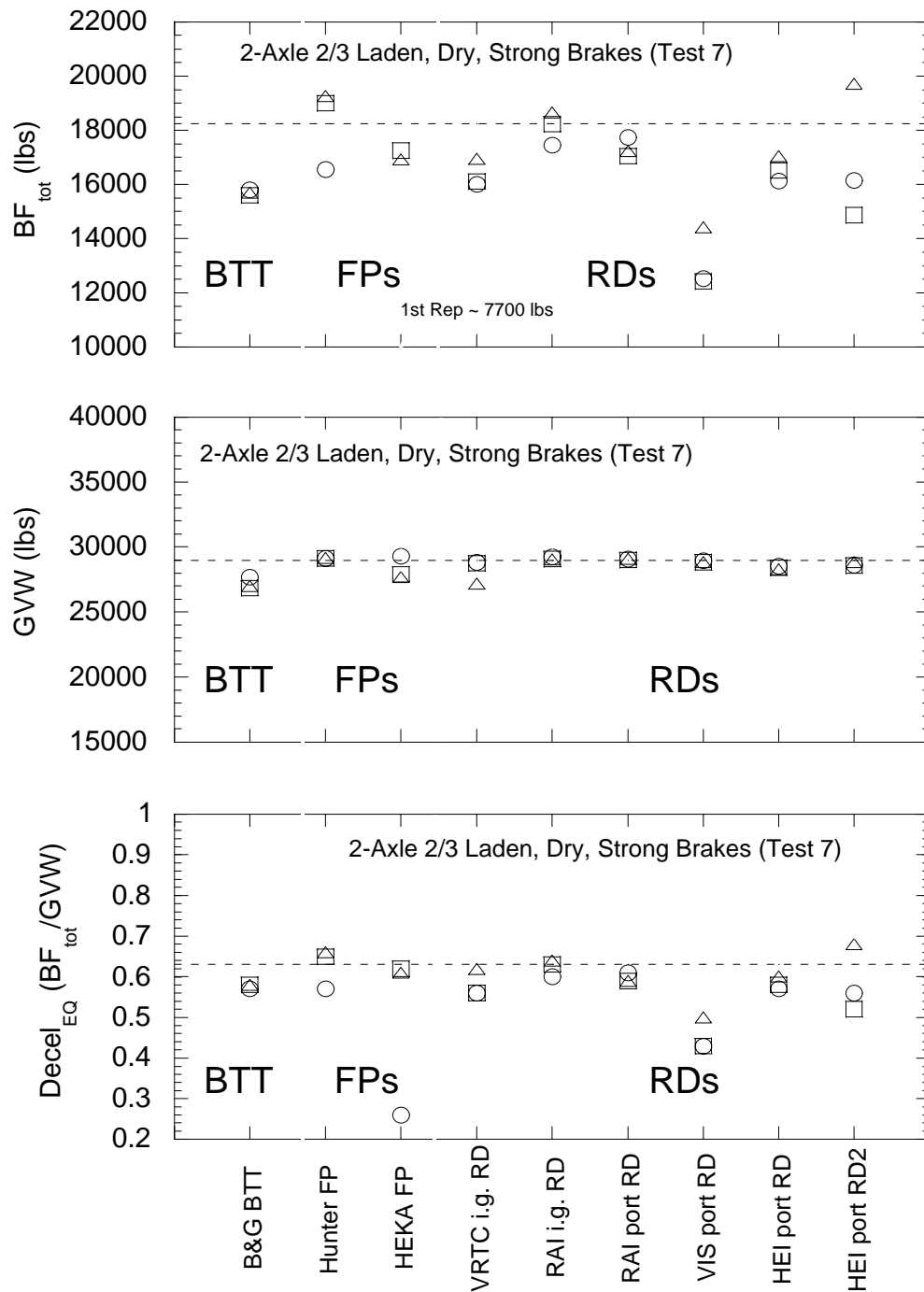


**Figure 12. Strongly braked 2-axle vehicle, unladen, dry (Test 5).**

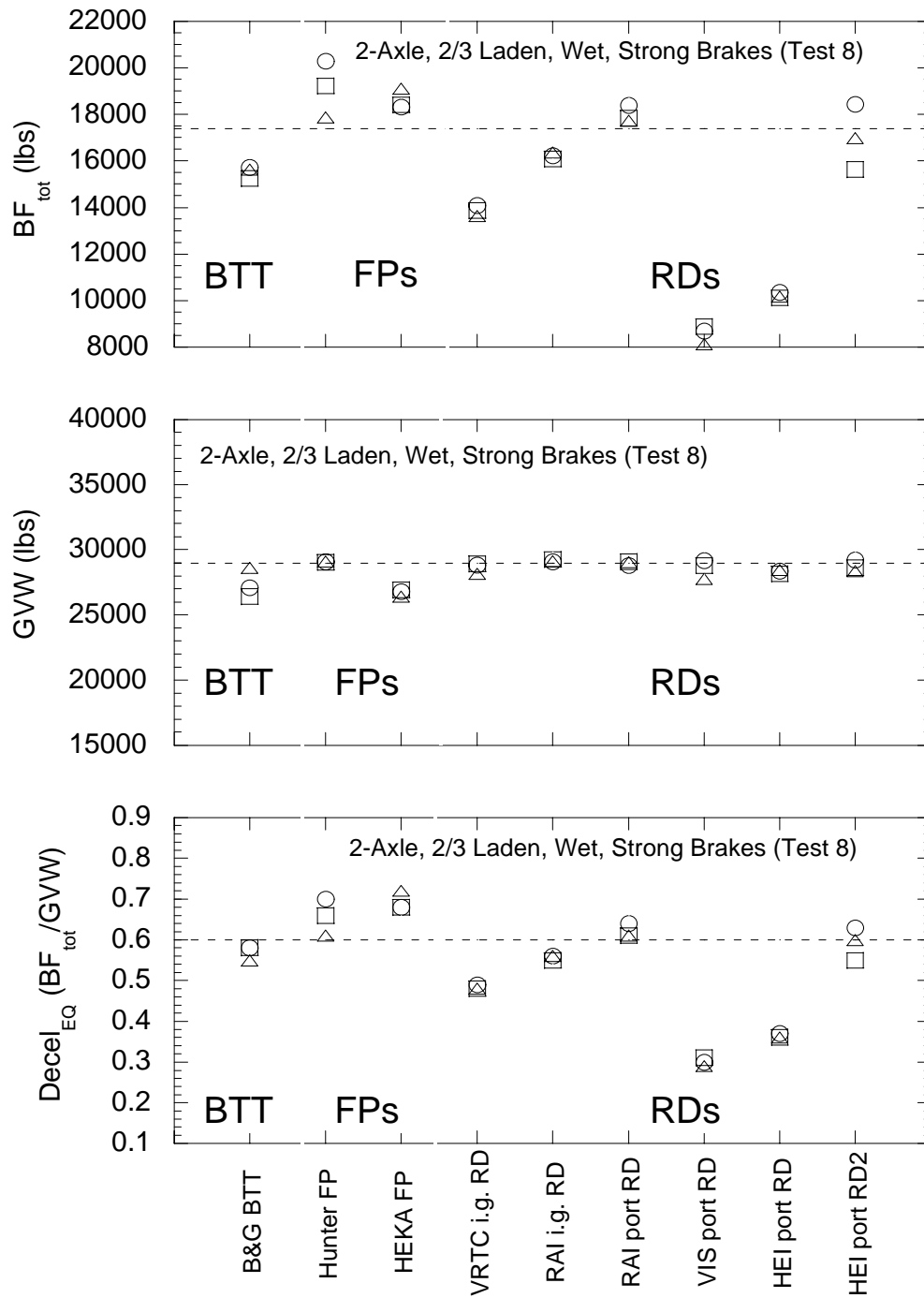
**Data for replicate 1 (○), replicate 2 (□) and replicate 3 (△) are plotted. The dashed lines represent the reference data from 32.2 km/hr (20 mph) on-road stops and certified scale weight measurements.**



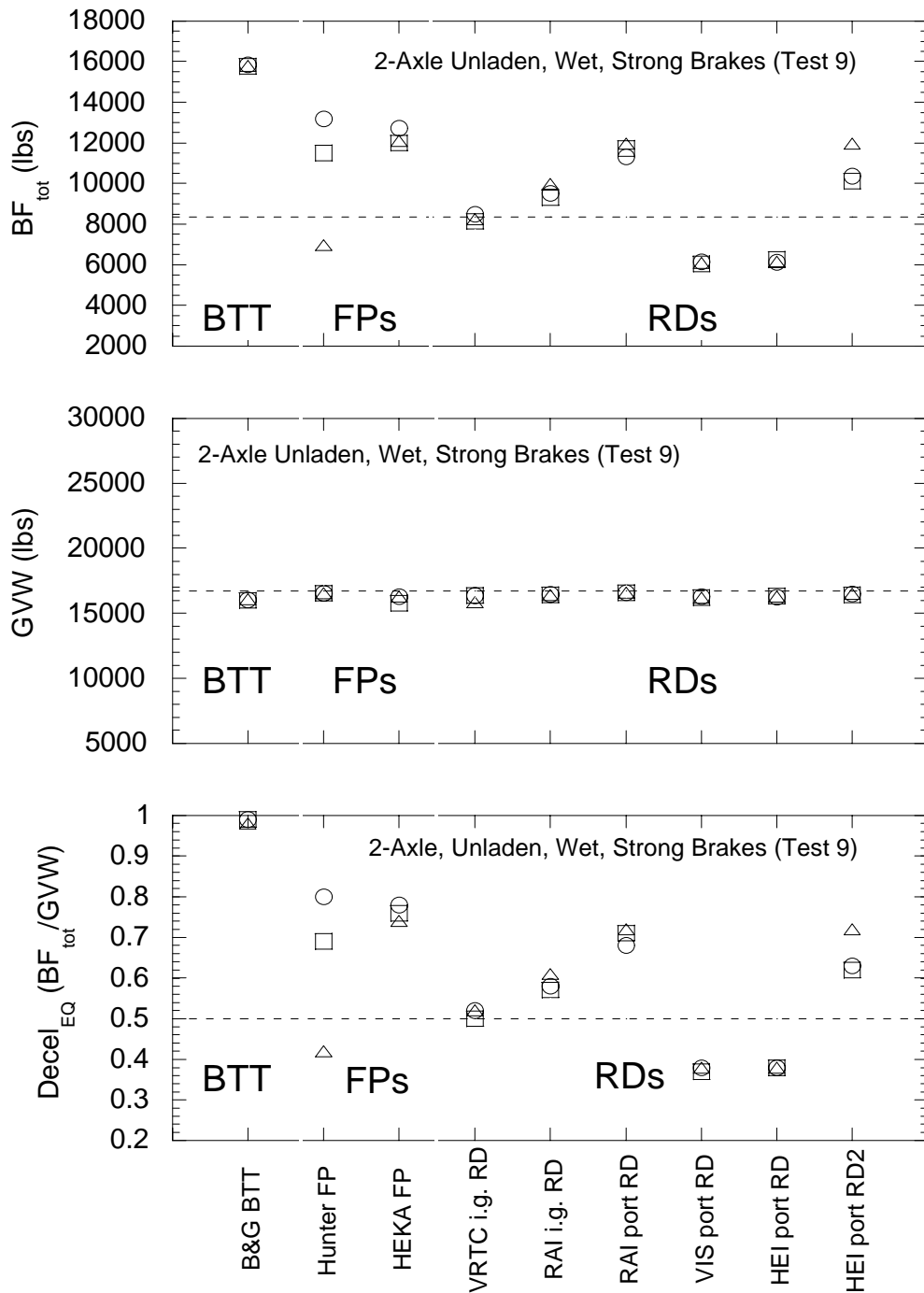
**Figure 13. Strongly braked 2-axle vehicle, 1/3 laden, dry (Test 6).**  
**Data for replicate 1 (○), replicate 2 (□) and replicate 3 (△) are plotted. The dashed lines represent the reference data from 32.2 km/hr (20 mph) on-road stops and certified scale weight measurements.**



**Figure 14. Strongly braked 2-axle vehicle, 2/3 laden, dry (Test 7).**  
**Data for replicate 1 (○), replicate 2 (□) and replicate 3 (△) are plotted. The dashed lines represent the reference data from 32.2 km/hr (20 mph) on-road stops and certified scale weight measurements.**



**Figure 15. Strongly braked 2-axle vehicle, 2/3 laden, wet (Test 8).**  
**Data for replicate 1 (○), replicate 2 (□) and replicate 3 (△) are plotted. The dashed lines represent the reference data from 32.2 km/hr (20 mph) on-road stops and certified scale weight measurements.**



**Figure 16. Strongly braked 2-axle vehicle, unladen, wet (Test 9).**

Data for replicate 1 (○), replicate 2 (□) and replicate 3 (△) are plotted. The dashed lines represent the reference data from 32.2 km/hr (20 mph) on-road stops and certified scale weight measurements.

In summary, the following observations on  $\text{decel}_{\text{EQ}}$  and  $\text{BF}_{\text{TOT}}$  were made for the strongly braked vehicle:

- The different test surfaces and test methods of the PBBTs led to different results for each class of PBBTs. Except for the VIS, the PBBTs could at a minimum predict the measured on-road deceleration of the vehicle in the dry condition, in all loading conditions tested except the 2/3 laden. In the 2/3 laden case, the  $\text{decel}_{\text{EQ}}$  appears to be limited by test surface COF, and is above 0.5 for all PBBTs except the VIS RD. As such, the variations observed in the results are not a safety concern. However, some accommodation must be made to incorporate the expected road/tire COF for accurate stopping distance predictions.
- The FP testers showed higher  $\text{BF}_{\text{TOT}}$  variability in these tests of strongly braked vehicles (Tests 5-9) than in tests of the weakly braked vehicles (Tests 1-4). This may be an indication of the sensitivity of this FP testers to driver performance because at higher BF, a wheel can lock. It may also be that skidding created some dynamic loading effects for the FP testers that affected the results. If skidding occurs, Hunter does not consider the results valid and requires a retest.
- The VIS RD showed lower BFs compared with all the other PBBTs, as well as compared with the other RDs. This indicates either a lower COF surface or an earlier test termination which limited the maximum measurable BF. These possible causes should be investigated and resolved.
- The BTT reported a high  $\text{decel}_{\text{EQ}}$  for the unladen and 1/3 laden tests (Tests 5, 6 and 9) compared with the reference value, but a low reported  $\text{decel}_{\text{EQ}}$  for the 2/3 laden cases. Analysis of the results indicated that the BTT measured the same  $\text{BF}_{\text{TOT}}$  (approximately 15,700 lbs.) for all vehicle conditions, independent of loading or the presence of water. This is consistent with its mode of operation. At the time of the round robin, the BTT software was set to terminate the test when the BF on a wheel reached 0.5 times the  $\text{GAWR}/2$ . For a given  $\text{COF}^{15}$ , as the load increases, the BF available at the tire/road or tire/test surface interface increases as well. Therefore,  $\text{BF}_{\text{REF}}$  increases as the load increases. In Test 5 (unladen),  $\text{BF}_{\text{REF}}$  is equal to 9,686 lbs. while in Test 8 (2/3 laden),  $\text{BF}_{\text{REF}}$  is equal to 17,382 lbs. In the 2/3 laden case, the value of the pre-set cut-off of 0.5

---

<sup>15</sup> From elementary physics, the frictional force,  $F$ , is proportional to the normal load,  $N$ , through the coefficient of friction (COF),  $\mu$ , as shown in the equation  $F=\mu N$ .

times the GAWR/2 was smaller than 17,382 lbs, the BF developed (and measured on the other PBBTs or during the road stop), whereas in the unladen case, the value equal to 0.5 times the GAWR/2 was greater than 9,686 lbs, the BF developed during the on-road stops or the other PBBT tests. As such, the  $BF_{TOT}$  reported by the BTT was low in the 2/3 laden tests while it was high in the unladen and 1/3 laden tests.

### **3.2.2 REPEATABILITY**

In part 2, the influence of the loading and surface conditions on repeatability of BF measurements was evaluated for axle 2 of the strongly braked vehicle. As the vehicle GVW is increased, the load of axle 2 changes more than that of axle 1. In addition, lift-off (for RDs only) is more significant for axle 2 than for axle 1.

#### **3.2.2.1 Repeatability for overall GVW**

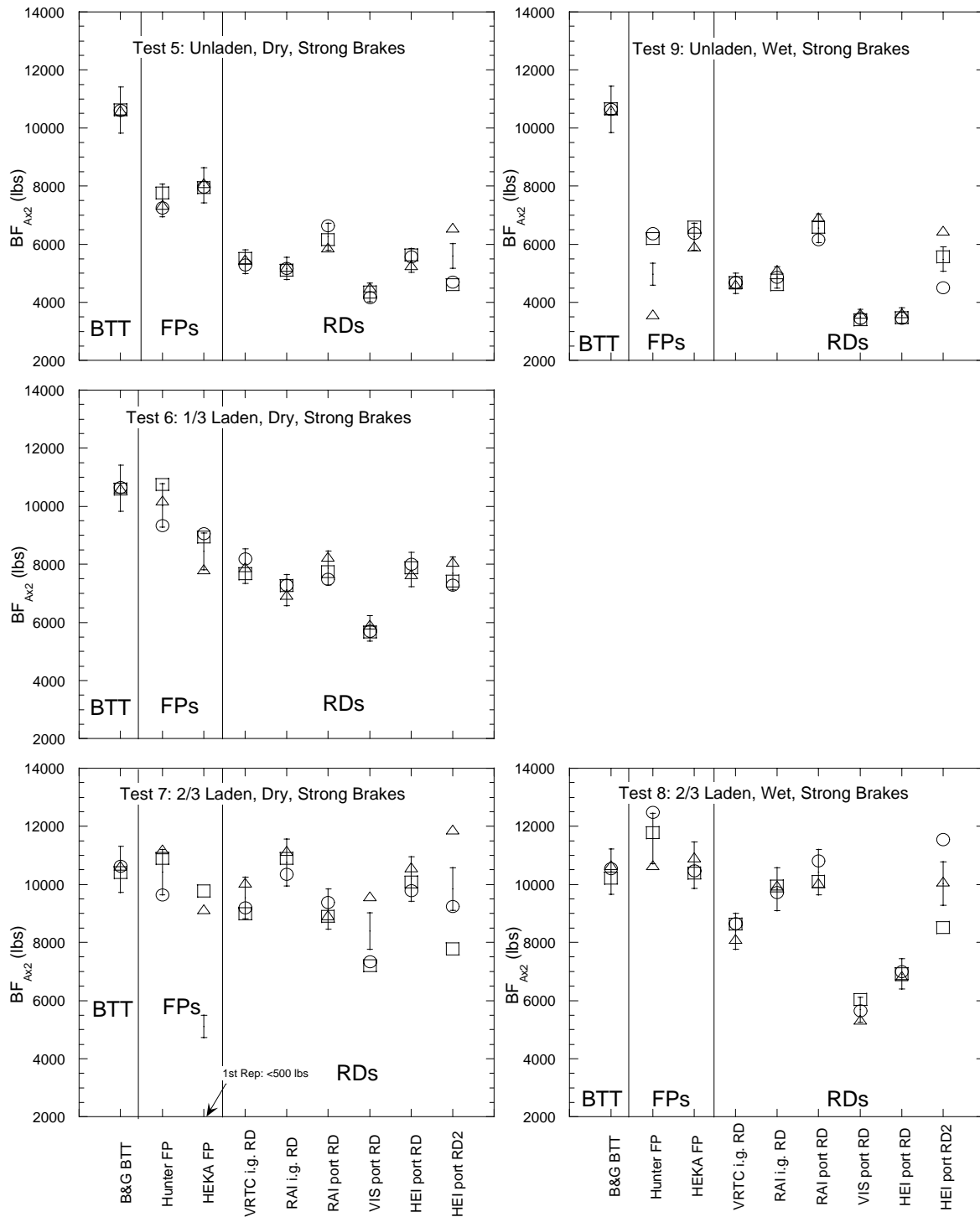
Figures 12-16 confirm that the repeatability of GVW measurements was not affected by the vehicle's braking capability or the COF of the test surface. 97 percent of the measurements were within the ARR for GVW ( $\pm 3$  percent, as listed in Table 5).

#### **3.2.2.2 Repeatability for strong BFs**

Figure 17 shows that 93 percent of the measurements fell within the ARR.

- One Hunter FP measurement was low and outside the ARR in both wet tests (Tests 8 and 9). This was likely due to wheel lockup, or variation in brake application by the driver. Both cases would require re-testing.
- The HEKA FP had one low value on Test 7, apparently due to data acquisition problems (Table C7)
- The VIS RD reported a high BF for the third replicate of Test 7 (cause unknown).
- Finally, the HEI experimental RD (RD2) reported high values for the third replicate in three of the five cases.
- All other PBBTs showed acceptable repeatability for measuring strong BFs, independent of loading and test surface conditions.





**Figure 17. Repeatability of PBBT-reported BF measurements for axle 2 on the strongly-braked 2-axle vehicle (Tests 5 - 9).**

**Data for replicate 1 (○), replicate 2 (□) and replicate 3 (△) are plotted. The error bars represent the acceptable repeatability range for BF (± 7.5 %, as listed in Table 5).**

For the RD tests in which the BF was outside the ARR, the results obtained for the third replicate indicate that chocking of the wheels may have contributed to an increased measurable BF. The increase in BF may be related to a decrease in the effect of lift-off. As such, standard test procedures for use in enforcement should take wheel chocking into consideration.

### **3.2.3 EFFECT OF TEST SURFACE**

The effect of the test surface condition was also examined during the second part of the testing program. The PBBT results were obtained for two loading configurations (empty and 2/3 laden) under both dry and wet conditions. Since the GVW measurements did not change with roller surface condition, the maximum measured BFs were compared to assess the effect of the test surface condition on PBBT results. Since the maximum measured BF is dependent on the frictional force ( $F$ ) between the test surface and the tire<sup>15</sup>, for the same loading conditions ( $N$ ), the apparent available BF will be affected in proportion to the COF ( $\mu$ ) between the test surface and the tire. As such, a wet test surface (i.e., lower COF) may be expected to show some decrease in BF. If this decrease is on the order of 10 percent or less, then the effect of test surface is not considered significant because the expected real life variations are  $\pm 5\%$  (see Table 5 in Section 3.1).

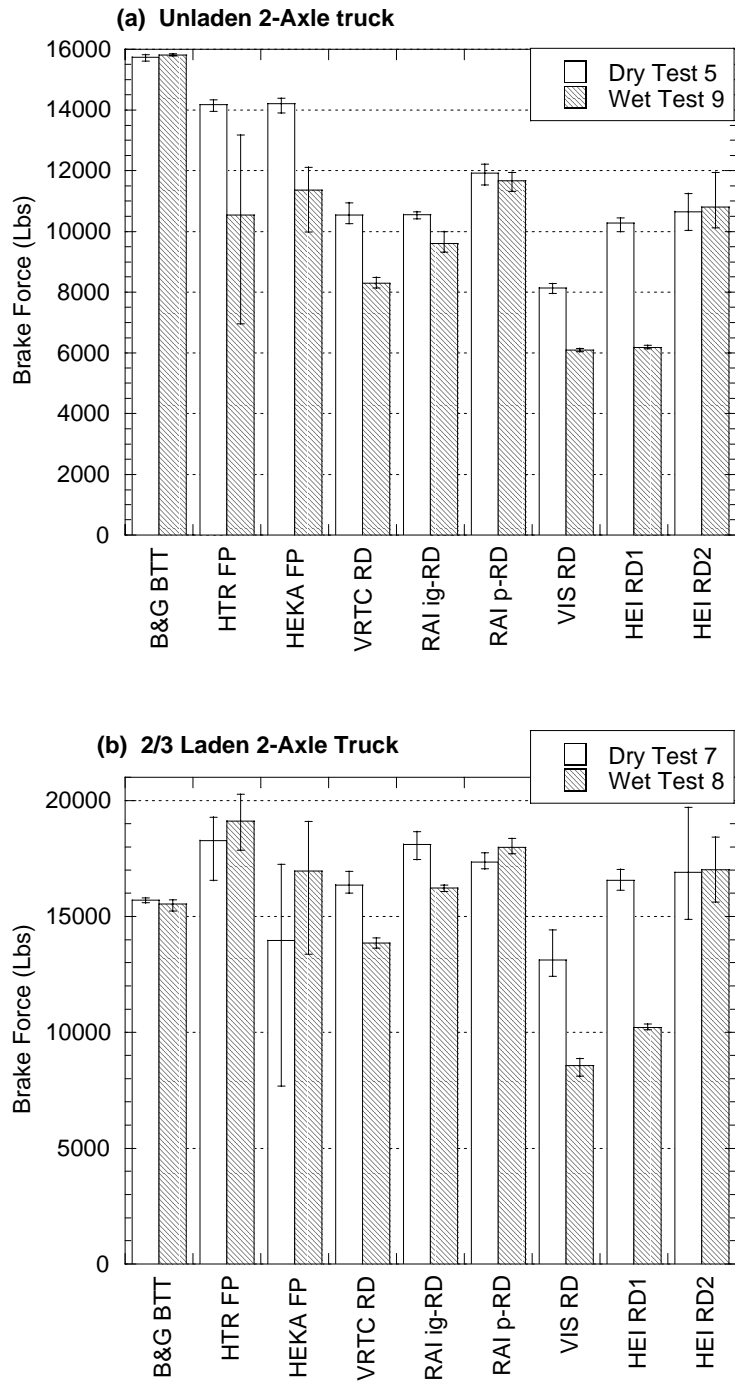
Photographic documentation of the “wet” tests is presented in Appendix A. Brake forces obtained under dry and wet conditions are plotted in Figure 18 for each PBBT, in both the (a) unladen and (b) 2/3 laden truck configurations. The error bars represent the minimum and the maximum measured  $BF_{TOT}$  of the three replicate measurements.

The B&G BTT was affected by less than one percent by the wet conditions. The total BFs measured by the BTT for the unladen vehicle was the highest of any of the PBBTs. This was the result of the principle of operation of the BTT, since the BF is not limited by slip of the tire against the test surface.

The results of the RAI portable RD and the HEI experimental RD (RD2) were also minimally affected by the wet surface, for both the empty and the 2/3 laden trucks, with variations on the order of 2.5 percent or less.

---

<sup>15</sup> According to  $F=\mu N$ , for a given load ( $N$ ), the frictional force ( $F$ ) is proportional to the coefficient of friction ( $\mu$ ).



**Figure 18. Total Brake Forces (Average of 3 tests) as a function of dry and wet PBBT test surface for (a) unladen and (b) 2/3 laden 2-axle truck with fully adjusted and strong brakes. The error bars represent the minimum and the maximum measured  $BF_{TOT}$ .**

The RAI in-ground RD showed a moderate effect of wet versus dry conditions, with up to a 10 percent reduction in maximum measured brake force.

A clear effect on the maximum measured brake force was observed for several PBBTs. The reduction of reported BF was up to 21%, 35%, and 40% for the VRTC RD, the VIS RD and the HEI (standard roller surface) RD, respectively. This effect is considered unacceptable, and recommendations were made to the manufacturers at the time of the round robin.

For both the Hunter and the HEKA FP brake testers, the effect of a wet surface on the results was inconsistent and, in some cases, the data were scattered. For both FP testers, the BFs measured in the wet tests showed an approximate 20% decrease compared to the dry test for the unladen vehicle. Conversely, from dry to wet, for the 2/3 laden vehicle, BFs measured by the Hunter and the HEKA FPs increased by 4% and 21%, respectively.

The current proposed specifications require a COF of 0.6 in the dry condition only. Since a clear effect on the PBBT-reported BFs was observed in the wet versus dry tests for some of the PBBTs, possible inclusion in the specifications of a minimum wet COF requirements should be considered.

## 4. Conclusions

The round robin was the first of its kind and constituted a significant milestone in the FMCSA's program to explore the use of PBBTs as a tool for law enforcement.

- Under most test conditions, the accuracy and repeatability of most of the participating PBBTs, regardless of the principle of operation, were acceptable for meeting the functional specifications, and therefore for use in law enforcement.
- The Hunter FP and the RAI in-ground RD showed the most immediate potential for use in law enforcement on weakly braked vehicles based on accuracy, repeatability of results, and when compared to measured vehicle decelerations in a 32.2 km/hr (20 mph) road stop.
- Where needed, factors or modifications to obtain acceptable PBBT performance for use in enforcement fell into one of two categories:
  - 1) Modifications consistent with the PBBT functional specifications that had been developed for eligibility for funding through the Motor Carrier Safety Assistance Program (MCSAP).
  - 2) Procedural modifications to improve the applicability of the PBBT results relative to on-road stopping results.
- Weight measurements were found to be affected by specific characteristics of the vehicles, or by the elevation and ramp configurations of the portable PBBTs.
- Consideration should be given to using additional criteria for judging brake effectiveness in cases where weights are unavailable or cannot be measured in a representative manner due to vehicle configuration. For example, when wheel lock up occurs, if the traction between the tire and the test surface is at least equal to 0.6 (as required in the PBBT functional specifications), the braking capability of the wheel would be considered adequate, regardless of the weight measurements. When the brakes are too weak to lock up the wheels, the weight measurements are critical, and alternative procedures and/or criteria would be required.
- The PBBT-measured BFs were in good agreement with the BFs measured with the torque wheel. Deviations were attributed to one of two causes:

- The algorithm used by PBBT manufacturers to acquire and manipulate the raw data and report a single BF value.
- In the case of the flat plate testers, the effect of dynamic loading.
- The roller dynamometers, as a class, reported slightly higher BFs for weakly-braked vehicles on dry pavement than the corresponding reference values derived from road stops. It was suspected that this was a result of either geometry of the wheel/roller contact patch or changes in brake torque output as a function of speed: the portable RDs operate at less than 2 km/hr (1.2 mph), while the road stops were performed at 32.2 km/hr (20 mph). Additional data are required in this area.
- Finally, the following recommendations were made to PBBT manufacturers to assist them in meeting the functional specifications:
  - Alter the test surface to meet minimum COF requirements.
  - Standardize test protocols, including data analysis and reporting procedures.
  - Develop appropriate calibration procedures.
- Some PBBTs showed that their BF results were unaffected by the condition of the test surfaces. Although the COF in wet conditions is not part of the proposed PBBT functional specifications at this time, PBBTs for which BF measurements were affected by the test surface conditions should address this problem.

## 5. Remaining Challenges

Remaining challenges for use of PBBTs in law enforcement include:

- Establishing appropriate test termination, data reduction and reporting algorithms for the PBBTs such that consistent results are obtained from machine to machine for a given vehicle.
- Developing standard test procedures for each type of PBBT.
- Developing training materials for inspectors using PBBTs for enforcement, including calibration and operating protocols.
- Establishing a list of special considerations for certain vehicle configurations (e.g. axle load or BF measurement applicability limitations). When applicable, modified testing procedures should be implemented.
- Developing regulations for individual brake pass/fail evaluation that are independent of WL, when WL measurements are either unavailable or significantly altered by the vehicle configuration.
- Establishing a policy or procedure for compliance testing, including documentation of calibration requirements necessary to meet potential legal challenges.

For a fundamental understanding of the relationship between PBBT testing and vehicle on-road performance, the following challenges are posed:

- Characterizing and understanding the sensitivity of brake force to velocity, static versus dynamic testing, wheel contact geometry or COF limitations as they are needed to establish the correlation between PBBT measurements and 32.2 km/hr (20 mph) road stops.