



U.S. Department  
of Transportation  
**Federal Railroad  
Administration**

# **REVISED RAILROAD TANK CAR DAMAGE ASSESSMENT GUIDELINES FOR PRESSURE TANK CARS**

---

Office of Research and  
Development  
Washington, D.C. 20590

**DISCLAIMER**

This document is disseminated under the sponsorship of the Department of Transportation in the interest of information exchange. The United States Government assumes no liability for the contents or use thereof. The United States Government does not endorse products or manufacturers. Trade or manufacturers' names appear herein solely because they are considered essential to the object of this report.

1000  
C

<b>1. Report No.</b>	<b>2. Government Accession No.</b>	<b>3. Recipient's Catalog No.</b>	
DOT/FRA/ORD/03/22			
<b>4. Title and Subtitle</b>		<b>5. Report Date</b>	<b>6. Performing Organization Code</b>
Revised Railroad Tank Car Damage Assessment Guidelines for Pressure Tank Cars		June 2002	
<b>7. Authors</b>		<b>8. Performing Organization Report No.</b>	
Jeffery C. Davis and Daniel H. Stone			
<b>9. Performing Organization Name and Address</b>		<b>10. Work Unit No. (TRAIS)</b>	
Association of American Railroads Transportation Technology Center, Inc. P.O. Box 11130 Pueblo, CO 81001			
<b>12. Sponsoring Agency Name and Address</b>		<b>11. Contract or Grant No.</b>	
U.S. Department of Transportation Federal Railroad Administration Office of Research and Development, MS 20 1120 Vermont Ave. NW Washington, DC 20590		DTFR 53-93-C00001, T.O. No. 115	
		<b>13. Type of Report or Period Covered</b>	
		<b>14. Sponsoring Agency Code</b>	
<b>15. Supplemental Notes</b>			
<b>16. Abstract</b>			
<p>Under Federal Railroad Administration (FRA) Contract No. DTFR 53-93-C-00001, Task Order Number 115, the Transportation Technology Center, Inc. (TTCI), a subsidiary of the Association of American Railroads (AAR), conducted a multi-phase research project focusing on the field assessment of damage to tank cars that have been involved in accidents.</p> <p>Phase I of the project focused on evaluating the technical foundations for the current tank car damage assessment guidelines developed by the AAR in the 1980's. A formal technical literature search conducted by Stanford Research Institute (SRI) identified which guidelines could be validated and which required additional modeling and validation in the project's Phase II effort.</p> <p>The Phase II effort of this research project was intended to accomplish the following:</p> <ul style="list-style-type: none"> <li>• Assess the validity of the existing guidelines using laboratory experiments and computer modeling</li> <li>• Estimate their margin of safety</li> <li>• Develop an analysis method for generating a damage assessment handbook</li> </ul> <p>This report uses the results of the Phase I and Phase II results to generate new guidelines.</p>			
<b>17. Key Words</b>		<b>18. Distribution Statement</b>	
Damage Assessment Guidelines, Tank Car		This document is available through National Technical Information Service Springfield, VA 22161	
<b>19. Security Classification (of the report)</b>	<b>20. Security Classification (of this page)</b>	<b>21. No. of Pages</b>	<b>22. Price</b>
		71	

### METRIC CONVERSION FACTORS

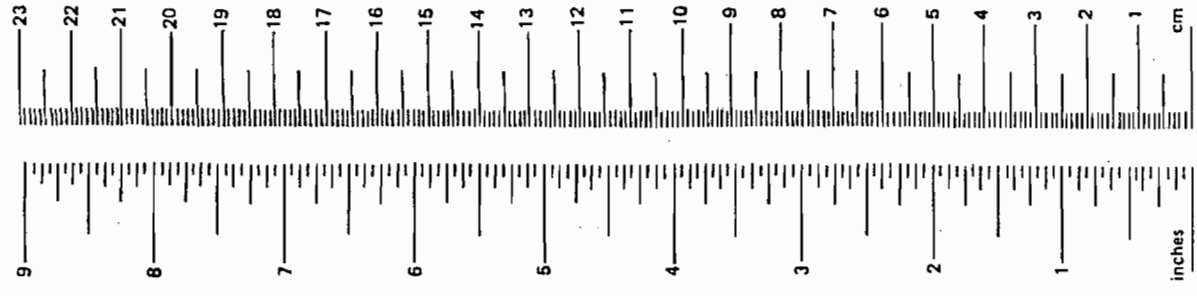

### Approximate Conversions to Metric Measures

Symbol	When You Know	Multiply by	To Find	Symbol
<b>LENGTH</b>				
in	inches	2.54	centimeters	cm
ft	feet	30.00	centimeters	cm
yd	yards	0.90	meters	m
mi	miles	1.60	kilometers	km
<b>AREA</b>				
in <sup>2</sup>	square inches	6.50	square centimeters	cm <sup>2</sup>
ft <sup>2</sup>	square feet	0.09	square meters	m <sup>2</sup>
yd <sup>2</sup>	square yards	0.80	square meters	m <sup>2</sup>
mi <sup>2</sup>	square miles	2.60	square kilometers	km <sup>2</sup>
	acres	0.40	hectares	ha
<b>MASS (weight)</b>				
oz	ounces	28.00	grams	g
lb	pounds	0.45	kilograms	kg
	short tons (2000 lb)	0.90	tonnes	t
<b>VOLUME</b>				
tsp	teaspoons	5.00	milliliters	ml
Tbsp	tablespoons	15.00	milliliters	ml
fl oz	fluid ounces	30.00	milliliters	ml
c	cups	0.24	liters	l
pt	pints	0.47	liters	l
qt	quarts	0.95	liters	l
gal	gallons	3.80	liters	l
ft <sup>3</sup>	cubic feet	0.03	cubic meters	m <sup>3</sup>
yd <sup>3</sup>	cubic yards	0.76	cubic meters	m <sup>3</sup>
<b>TEMPERATURE (exact)</b>				
'F	Fahrenheit temperature	5/9 (after subtracting 32)	Celsius temperature	'C

### Approximate Conversions from Metric Measures

Symbol	When You Know	Multiply by	To Find	Symbol
<b>LENGTH</b>				
mm	millimeters	0.04	inches	in
cm	centimeters	0.40	inches	in
m	meters	3.30	feet	ft
m	meters	1.10	yards	yd
km	kilometers	0.60	miles	mi
<b>AREA</b>				
cm <sup>2</sup>	square centim.	0.16	square inches	in <sup>2</sup>
m <sup>2</sup>	square meters	1.20	square yards	yd <sup>2</sup>
km <sup>2</sup>	square kilom.	0.40	square miles	mi <sup>2</sup>
ha	hectares (10,000 m <sup>2</sup> )	2.50	acres	
<b>MASS (weight)</b>				
g	grams	0.035	ounces	oz
kg	kilograms	2.2	pounds	lb
t	tonnes (1000 kg)	1.1	short tons	
<b>VOLUME</b>				
ml	milliliters	0.03	fluid ounces	fl oz
l	liters	2.10	pints	pt
l	liters	1.06	quarts	qt
l	liters	0.26	gallons	gal
m <sup>3</sup>	cubic meters	36.00	cubic feet	ft <sup>3</sup>
m <sup>3</sup>	cubic meters	1.30	cubic yards	yd <sup>3</sup>
<b>TEMPERATURE (exact)</b>				
'C	Celsius temperature	9/5 (then add 32)	Fahrenheit temperature	'F



\* 1 in. = 2.54 cm (exactly)

## Acknowledgements

The author gratefully acknowledges the pioneering work done on tank car damage assessment by the late Roy Holden and the late William S. Pellini: Mr. Holden, for his infinite knowledge of the subject; and Mr. Pellini, for his well-documented research on the subject matter. Neither of these men held their views lightly, or arrived at conclusions without strong evidence to back them up. Mr. Holden in particular, cared deeply about the safety of "his" Bureau of Explosives Inspectors who would be using the guidelines in the field. Roy Holden was an icon in this business, and this report should be viewed as an extension and refinement of his work.

The objective of this report is to validate those guidelines where possible and to document the process carefully in order that those who follow us may see how we arrived at our conclusions. Where our research did not agree with the existing guidelines, we have let the research drive the conclusions. To the extent possible, subjectivity is avoided in drawing conclusions

Special thanks and recognition to Dr. Richard Klopp and Dr. Steve Fitzpatrick formerly of Stanford Research Institute (SRI) for the integrity of their research, and Mr. Norman Smith of Hulcher Resources, Inc. for donating his time, insight, and personal knowledge of the incidents in this report.

Special thanks also to the Department of Transportation, Federal Railroad Administration for recognizing the importance of this work and for sponsoring the research.

(blank)

## EXECUTIVE SUMMARY

Under Federal Railroad Administration (FRA) Contract No. DTFR 53-93-C-00001, Task Order 115, the Transportation Technology Center, Inc. (TTCI), a subsidiary of the Association of American Railroads (AAR), conducted a multi-phase research project focusing on the field assessment of damage to tank cars that have been involved in accidents. Phase I of the project focused on evaluating the technical foundation for the current tank car damage assessment guidelines developed by the AAR in the early 1980's. A formal technical literature review conducted by Stanford Research Institute (SRI) identified which guidelines could be validated and which required additional modeling and validation in the project's Phase II effort.

Recently, the original guidelines were reviewed to determine how or if they could be validated. After consulting with experts in the tank car, railroad, and chemical industries it was determined that the individuals who developed the damage assessment guidelines are no longer available to substantiate them. The formal literature review did not specifically mention the establishment of the guidelines or the basis on which they were established. Subsequent to SRI's review it was discovered that a document titled *Container Integrity Assessment* was used during mid-1980 as a student handout by TTCI's Emergency Response Training Center at the FRA's Transportation Technology Center, Pueblo, Colorado. This handout provided the rationale for some of the recommendations made in the guidelines.

Since 1983, many new engineering tools have been developed that can be readily adapted to examine the validity of guidelines, their built-in safety factors, and the methodology on which these conclusions are based.

From the recommendations of the Phase I program, a Phase II effort was designed and performed to address the highest priority issues. This Phase II effort was intended to accomplish the following:

- Assess the validity of the existing guidelines using laboratory experiments and computer modeling
- Estimate their margin of safety
- Develop an analysis method for generating a damage assessment handbook

The following conclusions can be drawn from the research conducted during Phase I and II:

- The existing guidelines involving cracks are valid, for the most part, because they require that the tank cars be unloaded for almost any crack. The existing guidelines are also valid for cases in which a crack occurs in an attachment weld – unless the crack is accompanied by other damage or is extraordinarily long, and such cracks will result in leaks instead of extending catastrophically.
- The existing guidelines for base-metal scores and gouges are valid, with safety factors ranging from 1.3 to 2.1. The guidelines for scores or gouges where only weld bead reinforcement is removed are valid because of the extra strength of the weld filler metal and because, even if the weld contains an undetected crack, the crack is unlikely to extend catastrophically in the absence of other damage such as a dent.



- The existing guidelines for wheel burns are valid with a safety factor of roughly 1.4 to 1.7.
- The existing guidelines for otherwise undamaged dents should be modified to remove dependence on dent radius of curvature. New research has revealed that radius of curvature has little bearing on propensity for failure. At pressures near and above 100 psi, dents are forced back out to yield large radii of curvature and can almost disappear at relief valve discharge pressures.
- Recent research has also shown dents that have no other damage (i.e., cracks, scores, or gouges) and do not involve welds appear unlikely to crack no matter what the radius of curvature. Comparatively, dents with cracks are dangerous because cracks at dent roots can easily extend when driven by the pressure-induced bending moment. Thus existing dent guidelines should be reformulated and based on an assessment of the likelihood that a dent contains a hidden crack.
- As demonstrated in this work, stresses in an undamaged tank are primarily due to internal pressure and not gravity loads induced by the lading. Thus, re-railing operations on undamaged tank cars will generate stresses that are negligible in magnitude compared with the pressure stresses.

Accordingly, the revised guidelines will stress the following:

- The contents of the tank should be verified with the shipping papers before proceeding any further in the decision-making process.
- If the tank fails ANY of the guidelines, it should be unloaded OR have the pressure reduced as soon as possible.
- If the tank passes all the guidelines, it can be safely lifted.
- Catastrophic failure is not likely without a 7-foot or longer longitudinal dent.
- These guidelines do not apply to a tank that has suffered fire damage.

- Determining tank pressure and temperature are vital first steps in the damage assessment process.
- Risk of tank failure is a function of lading pressure and tank damage. A change in either constitutes a variable that must be considered (e.g., increase in ambient temperature).
- Venting product vapors is a much faster method of reducing pressure than transferring liquid. It is also a safer method if done properly; thus, reducing risk.
- Based on new research, the “Tank Car Dent Gauge” is obsolete, and any reference to it is deleted in the revised guidelines.
- Temperature and Pressure Tables for 22 of the most commonly transported flammable compressed gases transported by rail have been added to this tank car damage assessment handbook for easy reference by the responder.

To better ensure the safety of emergency response personnel and the public at large, it is necessary to provide those who are assessing tank car damage in the field with sound, qualitative evaluation techniques that they can use safely and reliably. Compiling this information into a clear, practical handbook will help emergency response personnel make critical decisions. This is an important effort that will significantly improve the safety of such operations.

## Table of Contents

<b>1.0</b>	<b>INTRODUCTION</b>	1
<b>2.0</b>	<b>BACKGROUND</b>	1
<b>3.0</b>	<b>SCOPE AND PURPOSE</b>	2
<b>4.0</b>	<b>APPROACH</b>	4
<b>5.0</b>	<b>RESULTS OF VALIDATION RESEARCH</b>	4
5.1	Guidelines for Cracks	4
5.1.1	Revision to Guideline on Cracks	4
5.2	Guidelines for Gouges	5
5.2.1	Guidelines Affecting Weld Reinforcements Only	5
5.2.2	Base Metal Gouges: Validation of Guideline, Depth versus Pressure Table for 340W Tanks	5
5.2.2.1	Revision to Guideline and Rationale	5
5.3	Guideline for Wheel Burns	6
5.3.1	Revision to Wheel Burn Guideline and Rationale	6
5.4	Guideline for Dents	6
5.4.1	Validity of 50-Percent Rating Reduction	6
5.4.1.1	History of Delayed Failures	7
5.4.1.2	Conclusions	9
5.4.1.3	Revision to Rail Dent Guideline and Rationale	10
5.4.2	Validity of Other Dent Guidelines	10
5.4.2.1	Validation of the Other Guidelines in these Groups	10
5.4.3	Delayed Fracture of ACFX 80417 (Flomaton, AL)	11
5.4.3.1	Revision to Guideline and Rationale	12
5.4.4	Short or Broad Area Dents	12
<b>6.0</b>	<b>SAFETY FACTORS OF THE GUIDELINES</b>	14
6.1	Depth of Score versus Allowable Internal Pressure Tables	14
6.2	Circumferential Dents	14
6.3	Cracks In Reinforcement Plates	14
6.4	Reverse Denting	14
6.5	Long Dents	14
<b>7.0</b>	<b>OVERVIEW OF THE DAMAGE ASSESSMENT GUIDELINES</b>	15
	<b>Glossary of Terms</b>	17
	<b>List of Acronyms</b>	19
APPENDIX A:	Updated Tank Car Damage Assessment Guidelines for Pressure Tank Cars	A-1
APPENDIX B:	Tank Car Damage Assessment Worksheet	B-1
APPENDIX C:	Compressed Gas Tables (22)	C-1

(blank)

## 1.0 INTRODUCTION

Under Federal Railroad Administration (FRA) Contract No. DTFR 53-93-C-00001, Task Order 115, the Transportation Technology Center, Inc. (TTCI), a subsidiary of the Association of American Railroads (AAR), conducted a multi-phase research project focusing on the field assessment of damage to tank cars that have been involved in accidents. Phase I of the project focused on evaluating the technical foundation for the current tank car damage assessment guidelines developed by the AAR in the early 1980's. A formal technical literature review was conducted by Stanford Research Institute (SRI) and evaluated to identify which guidelines could be validated and which required additional modeling and validation in the project's Phase II effort.

## 2.0 BACKGROUND

In February 1993, the TTCI produced *Field Product Removal Methods for Tank Cars*, an emergency response handbook. It was developed for the FRA under contract DTFR 53-82-C-00282, Task Order 31 and was produced for emergency response personnel who deal with tank cars that have been damaged in accidents and carry hazardous materials. Since its publication and subsequent use, a need has arisen for a companion handbook identifying proven and reliable damage assessment guidelines.

Since 1985, TTCI and other organizations have used a set of guidelines that were developed by the AAR in the late 1970's to teach emergency response personnel how to make judgements in the field as to the severity of damage to tank cars involved in accidents. These guidelines were developed to help emergency responders decide whether tank cars carrying hazardous materials shipped under pressure can be safely re-railed, should be unloaded in place, or whether nature should be left to take its course.

Recently, the guidelines were reviewed to determine how, or if, they could be validated. After consulting with experts in the tank car, railroad, and chemical industries, it has been determined that several individuals developed the guidelines but are no longer available to substantiate them. To better ensure the safety of emergency response personnel and the public-at-large, responders need sound, qualitative evaluation techniques that can be safely and reliably used to make these decisions. Compiling this information in a clear and concise handbook that will help emergency response personnel make critical decisions is an important effort that will significantly improve the safety of such operations.

The literature reviewed did not specifically mention the establishment of the guidelines or indicate the basis on which they were established. After SRI's formal literature search it was found that a document titled *Container Integrity Assessment* had been used as a student handout at TTCI's Emergency Response Training Center (ERTC) in the mid-1980's. This document provides the rationale for some of the recommendations made in the guidelines.

According to AAR personnel, the guidelines were developed by Roy Holden, a former AAR engineer with the Bureau of Explosives, and were based on experience gained while attending derailments and inspecting specimens from damaged or failed tank cars. Most of the available fracture analyses for tank cars are based on the work of William S. Pellini, who after a career at the Naval Research Laboratory, acted as a consultant to the AAR for many years. Mr. Holden reportedly interacted extensively with Mr. Pellini during the drafting of the guidelines, and the guidelines appear to be based, in part, on Pellini's work.

From the recommendations of the Phase I program, a Phase II effort was designed and performed to address the highest priority issues. This Phase II effort was intended to accomplish the following:

- Assess the validity of the guidelines using laboratory experiments and computer modeling
- Estimate their margin of safety
- Develop an analysis method for generating a damage assessment handbook

### **3.0 SCOPE AND PURPOSE**

These guidelines are intended to provide the emergency responder with some reliable criteria with which to make "go/no go" decisions when interpreting damage to pressure tank cars involved in derailments or accidents. In particular, they are intended to avoid exposing personnel to the phenomenon of delayed fracture of the tank car tank. This document is intended to be a handbook of damage assessment guidelines for pressure tank cars, to be used in conjunction with *The Handbook for Field Product Removal Methods for Tank Cars*, also available from the National Technical Information Service, Springfield, VA.

Occasionally, tank cars may be so badly damaged that a conventional transfer operation may not be an option. Unloading valves may be damaged, sheared-off, or inaccessible. Education pipes may be broken or cracked, excess flow valves may be seated, or the tank may be so badly damaged that re-orienting it to facilitate a transfer is inadvisable.

In such cases, *The Handbook for Field Product Removal Methods for Tank Cars* provides the responder with viable options such as flaring, or vent and burn. These damage assessment guidelines provide the following information for the responder and those responsible for dealing with railroad accidents:

- An explanation of delayed fracture
- A list of safety precautions that should be followed in order to minimize the hazards of performing tank car damage assessment
- A process to follow in inspecting a damaged tank car
- A form to use when inspecting a car for damage
- Factors that affect the severity of tank damage

- The type of tank car construction information required to interpret damage and how to obtain that information
- An explanation of the significant types of damage
- Guidelines for interpreting the severity of that damage
- A list of equipment required for damage assessment

This document also recognizes the dangers inherent in operations such as field transfers of compressed gases, an alternative often chosen when damage to a tank car is deemed too serious to allow rerailling. The decision to transfer a tank car's lading is often made because those in authority believe it is the safest option available without recognizing that the operation always involves the potential for hose or pump failure or other unanticipated events.

The fact that a tank car has derailed and is lying on its side is in itself no reason to mandate unloading the car in place. Unloading operations and other emergency product removal techniques carry with them inherent hazards that should be recognized and taken into consideration before such decisions are made.

#### **4.0 APPROACH**

In order to provide the reader with the basis for the recommended changes to the guidelines, the research of this project are presented in this report in the following manner:

- Summarize the results and conclusions of the laboratory testing and modeling performed by SRI.
- Present the results and conclusions of the research performed by TTCL, including the laboratory testing done on ACFX 80417 (delayed rupture at Flomaton, AL).
- Highlight the recommended changes to each of the guidelines and the rationale for making those changes.
- Develop a listing of the margins of safety for each of the guidelines.
- Provide recommendations for further research.
- Develop a revised set of guidelines and inspection procedures that can be readily understood and used by emergency responders.

This approach is essential in providing the reader with an understanding of why changes were or were not made in particular guidelines, the margin of safety they provide, and where additional research needs to be done to conclusively validate the guidelines.

## 5.0 RESULTS OF VALIDATION RESEARCH

A summary of the research project's findings with respect to the validity of the individual guidelines is presented. A copy of the Tank Car Damage Assessment Guidelines is provided in Appendix A.

### 5.1 Guidelines for Cracks

The earlier guidelines for cracks require unloading the tank car contents if any cracks are visible, with the exception that cracks in welds used to attach brackets or reinforcement plates are not critical unless the crack extends into the base metal. (Existing guidelines are presented in italics.)

*A crack in the tank metal indicates serious damage. Cracks in welds, used to attach brackets or reinforcement plates, are not critical unless the crack extends into the base metal. Welds securing reinforcement pads on the tank are designed to fail, allowing the attachment to break away without damage to the tank.*

*Any crack found in the base metal of a tank, no matter how small, justifies unloading the tank as soon as possible. However, if in a yard, the car may be carefully moved to a designated remote location in the yard for transfer.*

*When a crack is in conjunction with a dent, score or gouge, the tank should be unloaded as soon as possible without moving it."*

Pellini reports that there has been at least one rupture (not a delayed rupture) originating from a crack in an attachment fillet weld (Austin, Manitoba). The weld in question was used to attach an education tube guide to the inside of the shell. The rupture occurred during a derailment as the result of denting which caused a stress concentration at the change in stiffness between the base metal and the attachment. In cases where there is no other damage associated with the attachment weld crack, the effect of the stress concentration is much less critical. Since attachment welds are usually lightly stressed, a crack should not extend in an unstable fashion even if it reaches base metal.

#### Validation:

The research and history of delayed ruptures validates this guideline with a cautionary note that several instances of cracking in tank heads on cars equipped with head blocks occurred in Canada during 1998 and 1999.

#### 5.1.1 Revision to Guideline on Cracks

It should be noted that instances of base metal cracking underneath cracked sill pads have been documented in the past several years. There have been no cases of delayed rupture attributed to these cracks.

The part of the existing guidelines stating that a tank with a crack in it may be moved if the crack is not in conjunction with a weld nor any other form of damage appears to be valid as well. The research indicates that such cracks are not able to initiate, much less run, even under the lowest temperatures likely to be encountered in the field.



## 5.2 Guidelines for Gouges

### 5.2.1 Guidelines Affecting Weld Reinforcements Only

The guidelines for scores imply that scores affecting only the weld bead above the base metal are benign:

*“Scores or gouges crossing a weld and removing only the weld reinforcement are not critical.”*

– Two pieces of evidence tend to validate this guideline:

- Even if such a score caused an undetected crack completely through the weld, the SRI research shows that the situation is relatively safe.
- Experiments done by Pellini following the Waverly TN accident showed that very low temperatures or high dynamic loads had to be applied to cause fracture propagation.

### 5.2.2 Base Metal Gouges: Validation of Guideline, Depth versus Pressure Table for 340W Tanks

The guidelines for base metal gouges require unloading when the gouge depth exceeds half the pressure limits given in the guidelines. (Tables are included in the guidelines but omitted here.)

*“Tanks having scores or gouges should be unloaded in place when the internal pressure exceeds 1/2 of the allowable internal pressure listed in the tables below. Tables 1 and 2 show the allowable score depths and allowable pressures for 340W and 400W tanks, respectively.”*

Laboratory experiments and finite element modeling validated this Guideline, showing the most serious gouge allowed (1/4 inch) at the corresponding internal pressure, still gives a safety factor of almost 4 for cleavage fracture and 1.3 for complete root yielding.

#### 5.2.2.1 Revision to Guideline and Rationale

This Guideline is overly conservative and in fact, documentation recently discovered indicates that the intent of the original guidelines was to provide a safety factor of 2. Accordingly, the guidelines will be revised to reflect this, and the reference specifying that “...when the gouge depth exceeds one-half the pressure limits given in the Table” will be deleted. This still gives a margin of safety of 2:1.

### 5.3 Guideline for Wheel Burns

The guidelines state that wheel burns do not induce a high probability of failure:

*"If the maximum depth of the wheel burn exceeds 1/8", the tank should be unloaded as soon as possible. If the depth of the wheel burn is less than 1/8", the tank should be emptied at the nearest loading facility, provided it is moved with care; not in ordinary train service."*

Inasmuch as wheel burns are very similar to scores and gouges, the work done to validate those guidelines is applicable here. The only caveat being that wheel burns may exhibit metallurgical effects due to frictional heating. Pellini concluded, however, that, for the most part, these changes are superficial in nature and not of any consequence. Reference 17 in the Phase I report also showed that although cross sections of wheel burns sometimes contained cracks, they arrested without extending out of the heat-affected zone.

#### 5.3.1 Revision to Wheel Burn Guideline and Rationale

This will be revised to clear up the existing ambiguity, as the current guideline can be confusing to the responder. The revised Guideline will read as follows:

*"If the car is loaded, and the depth of the burn is 1/8 inch or less, the car may be transported to the closest unloading point. If the depth exceeds 1/8 inch, the load should be transferred without further transportation. If the depth exceeds 1/4 inch, the car should be transferred immediately. In the latter case, the responder should consider off-loading the car by pump (see *Emergency Product Removal Techniques for Tank Cars* for procedures) rather than pressure, to avoid raising the internal pressure of the car."*

### 5.4 Guideline for Dents

#### 5.4.1 Validity of 50-Percent Rating Reduction

The guidelines state that a long rail burn dent reduces the rating of a tank by 50 percent:

*"Sharp dents in the shell of a tank (cylindrical section) which are parallel to the long axis are the most serious as these dents drop the rating of the tank by 50 percent."*

The research done by SRI questions the validity of this guideline. A simple linear elastic fracture mechanics analysis indicates that long dents, parallel to the long axis of the tank, may develop stress intensities that are at or above the measured fracture toughness of A515-70 steel. Additionally, finite element analysis calculations and intuition indicate that the bottom of the dent has experienced a reversed cycle of plastic straining which may significantly reduce the fracture toughness for ductile rupture. Apparently, if there is a crack with applied bending moment, the crack will propagate (if there is sufficient internal pressure to drive the crack). Without a dent there can be no moment.

At the Texarkana, TX incident, delayed fracture occurred at pressures around 200 psi due to the presence of long rail dents. At the Waverly, TN incident, failure occurred at 50°F (LPG has a vapor pressure of 126 psig at 68°F (Pellini 1983).

#### **5.4.1.1 History of Delayed Failures**

TTCI has documented eight cases of tank cars that failed from delayed fracture attributable to long dents:

- Two cases of delayed fracture that developed approximately 40 hours following a derailment (Waverly, TN and Cuming, IA).
- One leakage type failure (arrested brittle fracture) that developed while the car was being loaded with LPG (Sarnia, ON).
- One leakage type failure that occurred while the car was being moved during re-railing operations (Flomaton, AL).
- Four arrested brittle fractures that developed during hydrostatic reforming to pop-out dents (one in Texarkana, TX and three others at another tank car shop).

All but one of these cases (Flomaton, AL) involved long dents more or less parallel to the long axis of the tank. The Flomaton car involved a long circumferential dent on the bottom of the car (50+ inches).

##### *Delayed failures after derailments:*

1. Waverly, TN, 1978. UTLX 83013, 112A400W, as-rolled 212B steel. Fracture occurred approximately 40 hours after the derailment resulting in catastrophic failure of the tank. Fracture initiation was at the point where a 12-foot long rail burn dent 3 inches deep crossed a girth weld. Lading was LPG. Failure occurred after the ambient temperature increased from 30°F to 50°F.
2. Cuming, IA, 1963. GATX 84429, 112A340W, dual diameter car built in 1963, as-rolled A-212B steel. Fracture occurred approximately 40 hours after the derailment, resulting in catastrophic failure of the tank. Fracture initiation point was at the point where a 15-foot long rail burn crossed a girth weld at the tank diameter transition point. Lading was Anhydrous Ammonia. The reason for failure is not entirely clear, but it is believed that the small increase in ambient temperature after the derailment was sufficient for fracture initiation.

*Tank failures during shop-reforming procedures:*

Shop reforming involves applying hydrostatic pressure to a damaged tank car in order to “pop-out” a dent. TTCI has no formal data on how many cars this procedure has been successfully performed. Pellini documented four cases of tanks failing during this process.

1. Texarkana, TX, 1980. ACTX 32001, 112J340W, dual diameter car built in 1963, A212B as-rolled steel. This failure occurred at a tank car shop while trying to pop-out a head dent. During this process, the tank fractured at the location of an old rail dent on the underside of the tank. The tank fractured at approximately 200 psi (hydrostatic). The fracture initiation site was at the point where an old wheel burn dent approximately 10 feet long crossed a girth weld at the tank diameter transition weld.
2. Tank car shop. AMOX 33424, 112A400W, as-rolled TC-128B steel, fracture initiated at the site where a 15-foot long burn dent crossed a girth weld (approximate center of the car). Pressure at time of failure unknown (below pressure relief valve setting).
3. Tank car shop. UTLX 83069, 112A400W, as-rolled A-212B steel, fracture initiated at the point where a burn dent 20-foot long, 2 inches deep crossed a girth weld. Pressure at failure unknown (below pressure relief valve setting).
4. Tank car shop. UTLX 83649, 112A340W, as-rolled A-212B steel. Fracture initiated at the point where a rail burn dent 36-foot long, 5 inches deep crossed a girth weld. Hydrostatic pressure at the time of failure was between 200-250 psi.

*Delayed fracture during LPG loading:*

Pellini documented the following:

1. Sarnia, ON, 1979. NATX 32044, 112J340W, dual diameter car, A212B as-rolled steel. This failure occurred while the car was being loaded with LPG. Tank pressure at the time of the fracture is unknown. The fracture initiation site was at the point where an old wheel burn dent approximately 7 feet long, 1 inch deep crossed a girth weld at the tank diameter transition weld. The fracture arrested at 7 feet resulting in LPG leakage.

*Delayed fracture during re-railing:*

TTCI documented the following:

1. Flomaton, AL, 1996. ACFX 80417, 112T340W, TC128B as-rolled steel. This failure occurred during re-railing operations. This car sustained a dent 57 inches in diameter, 11 inches deep in the “A” end head that resulted in a ductile tear at the weld near the bottom of the dent. After this leak was patched, the car was being rolled to facilitate product transfer when another fracture developed on the bottom lower side of the car, 55 inches inboard from the circumferential head weld.

The fracture initiated at the point where the dent on the bottom of the car intersected a weld defect, apparently a field repair weld on a placard holder weld. The fracture was 35 inches long and arrested, resulting in product leakage (vinyl chloride). Given the relatively low vapor pressure of vinyl chloride at 49.9 pounds per square inch absolute (psia) at 68°F and the fact that the car had a pre-existing hole in it, one would not expect the internal pressure to have been much over 50 pounds per square inch absolute (psia) at the time of the long dent failure.

The following is a list of built dates for the cars discussed:

	<b>Serial Number</b>	<b>Built date</b>	<b>Steel</b>	<b>Cert. of Construction</b>
	ACFX 80417	1975	128B	F741008-C
	NATX 32044	1966	212B	166722
	UTLX 83649	1962	212B	16696
	UTLX 83069	1962	212B	15189
	AMOX 33424	1972	128B	26237
	ACTX 32001	--	--	--

#### **5.4.1.2 Conclusions**

Post-accident analysis of these cases revealed the following:

- In all cases (except the Flomaton car), the fracture initiated at crack-like defects in girth welds, at the point where the wheel or rail burn crossed the weld. The fracture on the Flomaton car initiated at the point where the circumferential dent intersected a defective weld on the placard holder bracket weld (probably a field weld).
- Delayed fractures tend to propagate in both directions from the initiation site. As in the Flomaton car, the fracture often travels almost equidistant from the initiation site in each direction.
- The steels were close to, but above, the Nil Ductility Temperature (NDT) of the plate in all cases.
- Six of the eight cases were of as-rolled A-212 steel. The other two involved as-rolled TC-128B.
- In all cases, the dent length exceeded 7 feet.

### 5.4.1.3 Revision to Rail Dent Guideline and Rationale

Inasmuch as all the failures referred to above involved fracture initiation at the juncture of a dent and a weld, this guideline will be revised as follows:

*“Long, sharp dents in the shell of a tank (cylindrical section) which are parallel to the long axis, and which cross a weld or extend to within one inch of a weld are the most serious as these drop the rating of the tank by 75 percent or more. Reduce pressure as soon as it is practical to do so safely and unload contents.”*

### 5.4.2 Validity of Other Dent Guidelines

The guidelines state:

*“For dents in the shell of tank cars built prior to 1967, the tank should be unloaded without moving it under the following conditions:*

- A minimum radius of curvature of 4 inches or less;*
- Have a crack anywhere;*
- Cross a weld;*
- Include a score or gouge.”*

Dents with a radius of curvature more than 4 inches are not a problem by themselves.

*“For dents in the shells of tank cars built since 1967, the tank should be unloaded without moving it under the following conditions:*

- A minimum radius of curvature of 2 inches or less;*
- Have a crack anywhere;*
- Cross a weld;*
- Include a score or gouge; or*
- Show evidence of cold work*
- Dents with a radius of curvature more than 2 inches are not a problem by themselves.”*

#### 5.4.2.1 Validation of the Other Guidelines in These Groups

The guidelines state that a crack in a dent of otherwise undamaged metal, i.e., away from a score or weld, is unlikely unless the dent is creased sharper than a 4-inch radius for A212B, or 2-inch radius for TC-128B.

SRI conducted laboratory tests in which A515-70 plates were bent welded sharper than a 1-inch radius at room temperature. Similar tests were conducted on TC128B as-rolled specimens at -112°F. Neither test resulted in failure. When either steel was cooled to -238°F, cleavage failure did result when the specimens were bent at 30-inch radii. Hence, the conclusion that dent formation would always result in rupture during an accident if the tank steel were on the lower shelf. As a practical matter however, lower shelf conditions could never be reached in the real world (i.e. in service conditions); thus, ruling out cleavage fracture.

For the case of ductile fracture, simple strain-to-failure considerations coupled with equations relating bend radius of curvature to surface strain suggest the 2-inch and 4-inch limits are conservative. However, these equations do not take into account the prior inward bending of the dent. This guideline needs further research before it can be validated since there is no way of knowing the effects of this reversed plastic deformation on the propensity of ductile failure.

#### **5.4.3 Delayed Fracture of ACFX 80417 (Flomaton, AL)**

This case of delayed rupture occurred during re-railing operations in 1996. Tank car ACFX 80417, a 112T340W constructed in 1974 of as-rolled TC128B steel, experienced a delayed rupture approximately 20 to 30 hours after being derailed and while being rolled over to facilitate product transfer. This car sustained a 57-inch diameter dent, 11 inches deep in the "A" end head resulting in a ductile tear at the head weld near the bottom of the dent. After this leak was patched, the car was being rolled to facilitate product transfer when another fracture developed on the lower side of the car 55 inches inboard from the head weld. The initiation site of the crack was the heat-affected zone of a 2-inch placard holder bracket weld, about midway in the valley of a circumferential dent 8 feet 3 inches long, on the bottom of the tank, about 7 inches deep. The radius of this dent was at least 6 inches. The fracture reached 35 inches long and arrested, resulting in product leakage (vinyl chloride). Given the relatively low vapor pressure of vinyl chloride (49.9 psia at 68°F), and the fact that the car had a pre-existing hole in it, it is not expected that the internal pressure was over 50 psia at the time of the long dent failure (see pg. 9, Delayed fracture during re-railing).

TTCI performed metallurgical tests on this car's tank steel and determined the following:

1. Crack initiation site was at the juncture of the dent and a defect in the weld, which secured the placard holder to the "R" side of the car.
2. The crack was not pre-existing, but was initiated at the time of the dent formation.
3. Spectrographic testing indicated the tank's steel met the as-rolled TC- 128B specification (although on the lower shelf of the specification).
4. Charpy V-notch testing indicated that the steel was at the lower shelf of other TC-128B steels in the data base

It is concluded that the internal pressure of the product, combined with the dent and possibly reverse bending forces experienced during the derailment and the rolling maneuver caused the crack to run. The fact that the crack arrested at 35 inches rather than running the full length of the dent is attributable to the sudden loss of an already relatively low internal pressure. It is important to note that the crack ran the full length of the bend.

This incident points to the potential critical nature of dents in welds or heat-affected zones. Even relatively large radii dents in the area of very short welds can cause failure provided other conditions are present.

In view of the results TTCI's examination of the Flomaton, AL delayed rupture, this Guideline will be revised to stress the criticality of even a circumferential dent of relatively large radius affecting the heat-affected zone of a weld. More emphasis must be placed on the criticality of dents in heat-affected zones, and on the importance of long dents.

#### **5.4.3.1 Revision to Guideline and Rationale**

TTCI's research on the Flomaton, AL car suggests that a dent (even a circumferential dent) that touches a weld or a heat-affected zone is potentially critical. Accordingly, this guideline will be revised as follows:

1. The tank pressure should be reduced or the contents transferred without moving it with dents in the shell described as follows:
  - Dent has a crack anywhere (except attachment or re-enforcement pads);  
or
  - Dent crosses a weld; or touches the heat-affected zone of a weld (1 inch on either side of the weld bead); or
  - Dent includes a score or gouge.

Dents without other associated damage are not a problem by themselves, unless they cross a weld or touch the heat-affected zone of a weld.

2. The tank should be unloaded without moving it, for tank cars built before 1967 with dents in the shell described as follows:
  - Dent has a crack anywhere; or
  - Dent crosses a weld, touches the heat-affected zone of a weld; or
  - Dent includes a score or gouge.

#### **5.4.4 Short or Broad Area Dents**

The guidelines imply that broad area dents in heads are benign unless combined with other damage or if bends are particularly sharp:

*"Massive dents in heads of the tank are generally not serious unless gouges or cracks are present with the dents.*

*Small dents in heads not exceeding 12 inches in diameter in conjunction with cold work in the bottom of the dent are marginal if they show a radius of curvature less than 4 inches for tanks built prior to 1967 or less than 2 inches for tanks built since 1967. If at all possible, such tanks should be unloaded in place. In any case the tank should be moved as little as possible and promptly unloaded."*



The research conducted by SRI failed to validate this guideline for the same reasons the rail dent guidelines were questioned: there is simply no way to know how much the dent has been pushed back out when the lading was removed, nor the effect on the metal of this reverse bending. However, in the case of head dents, the situation is mitigated by the following facts:

- The bending moment and tensile stresses for head dents are likely to be lower because head stresses are always lower than shell hoop stresses.
- The distance a crack could run is shorter.
- Head metal is often thicker than shell metal due to the way the head is formed.

## **6.0 SAFETY FACTORS OF THE GUIDELINES**

### **6.1 Depth of Score versus Allowable Internal Pressure Tables**

The tables in the guidelines give a safety factor of 4. The guidelines will be revised to give a safety factor of 2, which was the intent of the original guidelines (see reference 5).

The validity of this safety factor is confirmed by the calculations in the revised guidelines and by the laboratory experiments performed by SRI.

### **6.2 Circumferential Dents**

In view of the results of TTCI's examination of the car involved in the Flomaton, AL derailment, the guidelines will be revised to stress the potential criticality of even a circumferential dent when it crosses a weld of any length or the heat-affected zone of any weld. Thus, it is believed the safety of the guidelines is enhanced.

### **6.3 Cracks in Reinforcement Plates**

The instances of cracks in base metal beneath cracked pads adjacent to stub sills found recently in Canada indicate the need for a cautionary note in this guideline. While the intent of the guideline is clearly to make the differentiation in the responder's mind between base metal and pads, these recent discoveries of cracks behind head reinforcement pads are an indication that tanks may be cracking due to tank stiffening in the head area.

### **6.4 Reverse Denting**

The work done by SRI shows that under certain conditions, the pressure in a tank car can push out the dent such that the final dent shape shows little evidence of the full extent of deformation in the tank wall. The SRI reservations regarding the unknown amount of "reverse denting" that occurs immediately after the damage is sustained due to internal pressure warrants a cautionary note in the revised guidelines. This phenomenon is also a candidate for future research to completely validate the dent guidelines.

### **6.5 Long Dents**

The statement in the guidelines that a long dent that is longitudinal to the long axis of the car may reduce the tank's rating by 50 percent is incorrect. Such a dent in fact, *will* reduce the rating of the tank by *at least* 50 percent, before any other damage, and possibly 75 percent after damage because the hoop stresses are twice as great as those for circumferential or head dents. Further, long dents have resulted in tank failure at pressures as low as 25 percent of burst pressure.

In view of this, and the fact that there has never been a documented case of delayed failure attributable to a head dent, this guideline will stand as is until further research can be done to validate it.

There is some concern with respect to the issue of long dents. There have been two instances of pressure cars that have suffered long dents catastrophically rupturing approximately 40-hours after being derailed (Waverly and Cumming). In fact, every delayed failure on record, with the exception of the case of Sarnia, ON where the LPG lading, is attributable to a long dent.

## **7.0 OVERVIEW OF DAMAGE ASSESSMENT GUIDELINES**

Pressure tank cars may sustain massive damage without losing their contents. Of concern to the responder and those involved with wreck clearing operations, however, is the phenomenon of delayed rupture. There have been at least three cases (Cuming, IA; Waverly, TN; and Flomaton, AL) of pressure tank cars damaged in derailments rupturing hours after the derailment.

The Cuming and Waverly cases involved catastrophic rupture with tank fragmentation and explosion. The Flomaton case was the only instance TPCI is aware of where a pressure car being handled during re-railing operations sustained an arrested fracture and lost product (no fire or explosion was involved). Delayed rupture is particularly dangerous because response personnel and others are likely to be involved in wreck clearing operations during this time.

Although these guidelines have been used successfully for over 15 years, it should be recognized that judgements made in the field might not be exact. In addition, there are many factors that are not apparent to the emergency responder making the assessment. Conditions such as pre-existing cracks not visible to the responder, defects in material or workmanship of the tank and its welds, jackets, and thermal protection or other unknowns (such as pre-existing or accident-caused damage not visible to the responder) make tank car damage assessment inherently dangerous. With this in mind, it is always prudent to limit access to an accident site involving damaged compressed gas cars until a thorough damage assessment has been made.

## Bibliography

- Davis, J. C. "Analysis of Tank Car ACFX 80417, Delayed Rupture, Flomaton, AL Derailment," White Paper, Association of American Railroads, October 1997.
- Davis, J. C. and K. S. Pieratt, "Literature Search and Evaluation Pertaining to Damage Assessment of Tank Cars Involved in Accidents: Phase I Final Report," Association of American Railroads, Subcontract No. 940986, under Federal Railroad Administration Contract No. DTFR53-93-C-00001, Task Order 115, SRI International (Project 7483), Menlo Park, CA, October 1995.
- Davis, J. C., M. N. McCullough, and R. K. Larson, "Field Product Removal Methods for Tank Cars" Report No. FRA/ORD/92-27, Contract No. DTFR53-82-C-00282, Task Order #31, Federal Railroad Administration, 1992.
- Holden, Roy, "Tank Car Damage Assessment," Presentation to the Burlington Northern Railroad, Lincoln, NB, May 1989.
- Klopp, R. W., S. W. Kirkpatrick and D. A. Schockey, "Damage Assessment of Tank Cars Involved in Accidents: Phase II - Modeling and Validation," Report No. DOT/FRA/ORD-02/04, Federal Railroad, December 2002
- Pellini, W. S., "Analysis of Tank Car Failures Related to Rail Burn Dents," Research Report No. R-551, Association of American Railroads, Chicago, IL, June 1983.

## Glossary of Key Terms

- **Arrested fracture:** A fracture that stops before a flap is formed and catastrophic failure of the tank occurs.
- **Catastrophic failure:** (see total delayed fracture)
- **Cleavage failure:** A failure that occurs through cleavage fracture.
- **Cleavage fracture:** A fracture, usually of a polycrystalline metal, in which most of the grains have failed by cleavage (splitting/fracture of a crystal on a crystallographic plane of low index), resulting in bright reflecting facets.
- **Cold work:** The deformation of steel when it is bent at ambient temperatures without benefit of heat treatment or suffers an impact or static load (i.e., a tank sliding over a solid object with a rounded point).
- **Crack:** A narrow split or break in the tank metal which may or may not penetrate through the tank metal.
- **Delayed fracture:** The time period between initiation of a crack and the propagation of that crack to failure. This time period may range from hours to years. As opposed to more or less instantaneous failure during the dynamics of the derailment.
- **Dent:** A deformation that changes the tank contour from that of the original manufacture as a result of impact with a relatively blunt object (coupler or end of adjacent car).
- **Ductility:** The relative ability of a metal to bend or stretch without cracking.
- **Flap formation:** The phenomenon whereby a fracture follows a dent until the internal pressure pushes out the tank metal in a lateral direction. This action normally occurs when the fracture reaches a critical length of 9 to 15 feet (3-5 m). When the critical length is reached, the ends of the fracture turn 90 degrees and extend in a circumferential direction. Flap development results in total rupture of the tank car.
- **Girth weld:** The circumferential weld that joins the plates of a tank car tank.
- **Gouge:** The removal of the tank metal along the line of contact with another object. This causes a reduction in tank metal thickness.
- **Hoop stress:** Refers to the fact that the stress on the longitudinal part of the tank is twice as great as the stress on the circumferential part of the tank.
- **Heat-affected zone (HAZ):** The area in the undisturbed tank metal next to the actual weld material. This zone is less ductile than either the weld or the plate due to the effect of the heat of the welding process. The width of the HAZ is approximately the width of the weld bead on each side of the bead.
- **Internal pressure:** The force against the internal surfaces of the tank caused by the vapor pressure of the contents.
- **Jacket:** The thin metal (approximately 1/8") covering that holds the insulation and/or thermal protection in place and protects them from the elements. *Not* an outer tank!
- **Long dent:** A dent 7 feet or longer (2.3 meters). Long dents are serious for two reasons: Historically, catastrophic failures have involved a dent 7' long, and; A 7' long dent will almost invariably cross a weld or heat-affected zone.

### Glossary of Key Terms (continued)

- **Lower Shelf:** The approximately horizontal line of energy versus temperature where notched bar impact tests demonstrate a fully brittle or cleavage fracture surface. The lower ends when the steel's transition temperature is reached.
- **Macrocrack:** A crack that can be seen with the naked eye.
- **Microcrack:** A crack requiring a magnifying device to see.
- **NDT (nil ductility temperature):** The temperature at which a particular type of steel is entirely brittle.
- **Normalize:** The process of heating steel plates to approximately 1,400 degrees F., and then air cooling it after forming, but before fabrication, in order to heat treat the steel.
- **Partial delayed fracture:** A delayed fracture resulting in tank leakage rather than total or catastrophic failure of the tank. Such a fracture arrests before flap formation and allows the pressure in the tank to dissipate.
- **Radius of curvature:** Used to describe the sharpness of a curve (dent). A small radius of curvature indicates a small circle and a sharp bend; whereas, a larger radius of curvature indicates a larger circle and a gentler bend.
- **Rail burn:** A long dent, usually parallel to the length of the tank, which crosses a weld and causes cold work. The tank passing over a section of rail may cause rail burn.
- **Rail dent:** A long narrow dent caused by the tank dropping on the rail without relative sliding motion between the rail and the tank.
- **Score:** A relocation of tank or weld metals so that the metal is pushed aside along the lines of contact with another object. This causes a reduction in tank metal thickness.
- **Short dent:** A dent less than 7 feet in length (2.3 meters).
- **Tank:** "Tank" in this document refers to the actual tank car tank. It is comprised of shell plates welded together to form a cylinder. Formed heads are then welded on each end of the cylinder. Pressure tank car tanks are a minimum 9/16" thick after forming.
- **Tank Head:** The tub-shaped ends welded onto the cylindrical shell of a tank car.
- **Total delayed fracture (catastrophic failure):** A delayed fracture that extends along a long dent until it turns 90 degrees forming a flap. Such total delayed fractures have historically involved an explosion and ejection of the end tubs of the tank car over a long distance, and fragmentation of the center region of the tank.
- **Transition temperature:** The point where the properties of a steel change from ductile to brittle.
- **Wheel burn:** The removal of tank metal due to the tank coming into prolonged contact with a revolving wheel. Wheel burns often occur during the initial phases of a derailment after the car has left the tracks, but before the car overturns. In such a case, the tank center plate comes out of the truck bolster and rides on the rotating wheel, gouging out metal from the tank. Wheel burns often are preceded by a dent as the tank drops onto the flange of the wheel.

## List of Acronyms

AAR.....	Association of American Railroads
ASME.....	American Society of Mechanical Engineers
ASTM.....	American Society for Testing and Materials
BOE.....	Bureau of Explosives
BP.....	Boiling Point
CP.....	Critical Pressure
ERTC.....	Emergency Response Training Center
FRA.....	Federal Railroad Administration
HAZ.....	Heat-Affected Zone
LPG.....	Liquefied Petroleum Gas
NDT.....	Nil Ductility Temperature
NTIS.....	National Technical Information Service
PSIA.....	Pounds per square inch absolute
PSIG.....	Pounds per square inch gage
SRI.....	Stanford Research Institute
TTC.....	Transportation Technology Center
TTCI.....	Transportation Technology Center, Inc.

(blank)



**APPENDIX A:**  
**UPDATED TANK CAR DAMAGE**  
**ASSESSMENT GUIDELINES FOR**  
**PRESSURE TANK CARS**

(blank)

## Table of Contents

<b>1.0 SAFETY PRECAUTIONS .....</b>	<b>A-5</b>
<b>2.0 FACTORS AFFECTING THE SEVERITY OF TANK DAMAGE .....</b>	<b>A-6</b>
2.1 Ductility of Tank Metal .....	A-6
2.2 Tank Car Steel Specifications .....	A-6
2.3 Temperature of the Steel.....	A-7
2.4 Cold Work.....	A-7
2.5 Heat-affected zone .....	A-7
<b>3.0 TOOLS REQUIRED FOR TANK CAR DAMAGE ASSESSMENT.....</b>	<b>A-8</b>
<b>4.0 UNDERSTANDING DELAYED FRACTURE .....</b>	<b>A-8</b>
<b>5.0 INSPECTING A TANK CAR FOR DAMAGE .....</b>	<b>A-9</b>
<b>6.0 REVISED DAMAGE ASSESSMENT GUIDELINES .....</b>	<b>A-11</b>
6.1 Cracks.....	A-11
6.2 Scores.....	A-12
6.2.1 Calculating Minimum Tank Thickness .....	A-14
6.2.2 Calculating Safe Internal Pressure .....	A-14
6.3 Gouges .....	A-15
6.4 Wheel Burns .....	A-15
6.5 Dents .....	A-15
6.5.1 Rail Dents.....	A-16
6.5.2 Dents in the Shells of Tank Cars Built Before 1967 .....	A-17
6.5.3 Dents in the Shell of Tank Cars Built in 1967 and After .....	A-17
6.5.4 Massive Dents.....	A-17
6.5.5 Small Dents .....	A-17
<b>7.0 DISCUSSION OF RE-RAILING PROCEDURES .....</b>	<b>A-18</b>

## List of Figures

Figure 1. Heat-affected zone .....	A-7
Figure 2. Illustration: Crack in the Tank Metal .....	A-12
Figure 3. Illustration: Score.....	A-12
Figure 4. Illustration: Gouge Crossing Heat-affected zone.....	A-13
Figure 5. Illustration: Gouge .....	A-13
Figure 6. Illustration: Wheel Burn .....	A-15
Figure 7. Illustration: Dent .....	A-16
Figure 8. Illustration: Rail Dent .....	A-16
Figure 9. Maximum Principal Stress Distribution from 130-psi Internal Pressure and Lading.....	A-18

## List of Tables

Table 1. Comparison of Tank Car Steel Properties.....	A-6
Table 2. Limiting Score Depths for 340W Tanks.....	A-13
Table 3. Limiting Score Depths for 400W Tanks.....	A-13

## 1.0 SAFETY PRECAUTIONS

Response personnel must take the following precautions before inspecting pressure tank cars involved in a derailment:

- Control access to the emergency scene to minimize exposure to unauthorized personnel.
- Obtain a copy of the train consist (shipping papers) in order to determine whether hazardous materials are in the train. The consist will list the cars in the train from back to front (or front to back, depending on the railroad) by initials and number, and give an indication of the hazardous material contained in each car. Although the forces of the derailment may have affected the order of the cars in the train, the location of particular cars can sometimes be determined through a process of elimination.
- Wear personal protective equipment appropriate for the hazardous materials present (until it has been determined there are no leaks). Dress "down" only when it is appropriate to do so.
- Keep fire, lights, internal combustion engines, smoking materials, and other sources of ignition away from the area if there is a flammability hazard.
- If hazardous materials are present, determine if packages or tank cars are leaking by surveying the area with the appropriate monitoring instruments.
- Identify any tank cars in the train and determine whether they are pressure cars or general service cars.
- Secure the assistance of someone with experience and training to perform a damage assessment of any pressure cars in the derailment. Potential sources of this expertise are Bureau of Explosives Inspectors, railroad hazardous materials specialists, shipper representatives, and tank car manufacturers or repair personnel.
- Secure the assistance/advice of the shipper of the hazardous materials involved for detailed information on the characteristics and behavior of the material(s).

## 2.0 FACTORS AFFECTING THE SEVERITY OF TANK DAMAGE

### 2.1 Ductility of Tank Metal

Ductility is the relative ability of a metal to bend or stretch without cracking. Ductile materials tend to bend but not crack. Brittle materials tend to crack rather than bend. When a ductile steel tank does crack, it tends to be small; whereas, the crack in a brittle steel tank tends to run linearly and causes the tank to fail.

Four factors affect the ductility of tank steel:

- Specification of the steel
- Temperature of the steel
- Damage to the tank
- Heat-affected zone

### 2.2 Tank Car Steel Specifications

From 1937 to 1966, pressure tank car tanks were constructed of as-rolled ASTM A-212 grade B, AAR M-115, ASTM A-285 grade C, and ASTM A-515 grade 70. From 1967 to 1986, pressure tank cars were constructed of as-rolled TC-128 B steels. Compared to the steel used after 1966, these were relatively coarse grained. The TC-128 B has a transition temperature that is considerably lower than the previously used steels, and tends to bend rather than crack at normal operating temperatures.

**Table 1. Comparison of Tank Car Steel Properties**

Steel	Yield (min. ksi)	Ultimate (ksi)	Elongation (% in 8 in)	C Content (max. Wt %)	Mn Content (max. Wt %)
A212B /A515 Gr 70	48	70-85	27	0.31	0.9
TC-128B	50	81-101	16	0.25	1.35

Note: As of November 1999, there were approximately 7,000 of these pre-1967 cars still in service)

In 1986, requirements mandated that pressure tank cars be constructed of TC-128B normalized steel. Normalized TC-128B steel is much more damage tolerant than the previous steels used in tank car construction, primarily because it has a nil ductility temperature (NDT) that is about 40° F lower than the other steels. This lower NDT basically means that the car is less subject to brittle fracture over a wider range of temperatures. That is, the tank will tend to bend, rather than break. The following breakdown gives an indication of the percentage of cars constructed of each type of steel that are still in service as of 1998.

*Percentage of pressure cars by built date and steel type:*

- 15 percent built prior to 1966 (A212B or A515-70 or equivalent)
- 65 percent built between 1967 and 1985 (as-rolled TC-128B)

- 20 percent built since 1986 (normalized TC-128B)

### 2.3 Temperature of the Steel

The temperature of the steel affects its ductility. The higher the temperature of the steel at the time it is damaged, the more ductile it will be and the less risk there is for failure. This benefit is offset by the fact that the higher the ambient temperature, the higher the vapor pressure of the product in the tank.

If the tank is warm to the touch (100°F) the tank will be entirely ductile, regardless of the type of steel of which it is constructed.

### 2.4 Cold Work

Cold work is deformation of steel when it is bent at ambient temperatures or suffers an impact or static load; i.e., a tank sliding over a solid object with a round point. Any damage to a tank (other than that caused by fire) is by definition "cold work." Cold work reduces the ductility of the steel.

The transition temperature of the steel is raised sharply as a result of cold work. That is, the steel becomes more brittle at the point where the cold work takes place.

### 3.5 Heat-Affected Zone

The heat-affected zone (HAZ), is an area in the undisturbed tank metal on both sides of the actual weld bead (see Figure 1). The width of each zone is approximately the same as the width of the bead itself. This zone is less ductile than either the weld or the plate due to the deleterious effect of the heat generated by the welding process on the steel. The HAZ is most vulnerable to damage, as cracks are most likely to initiate there. This was the case with the Flomaton, AL car.

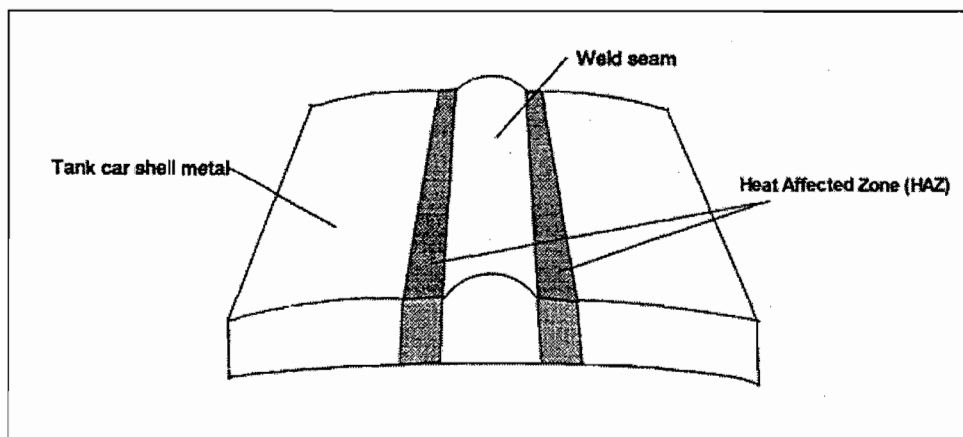

Figure 1. Heat-affected zone

### **3.0 TOOLS REQUIRED FOR TANK CAR DAMAGE ASSESSMENT**

- Depth gauge
- Magnifying glass
- Pressure gauges (up to 400 psi suitable for ammonia, LPG, and chlorine)
- Thermometer (for tank metal)
- Thermometer (for lading)
- Reducers from both 1 and 1/2 inches and 1 inch to 1/4 inch
- Teflon or other thread tape
- Tape measure
- Compressed gas handbook

### **4.0 UNDERSTANDING DELAYED FRACTURE**

In order for delayed fracture to occur, there must be a pre-existing crack in the tank metal. This crack may be microscopic or large, depending on the forces the tank has encountered. Such a crack may be caused by the tank striking or being struck by another object (e.g., a rail) during the dynamics of a derailment. Analysis of the cases above suggest that this crack will initiate where the dent crosses a weld (most often, a girth weld). In order for a micro-crack to become unstable and propagate, a critical stress level must be reached. Stress tends to make cracks grow. In the case of a tank damaged in a derailment, the principal cause of increased stress will be a rise in internal pressure. This pressure rise may be caused by a rise in the ambient temperature, fire impingement, or radiant heat. As the critical stress level is reached, the crack will start to grow, become unstable, and propagate. In essence, the crack “waits” for the necessary conditions of temperature, loading rate, and stress to develop. In the case of a long, straight dent, the crack will follow the line of the dent.

Depending on the length of the dent, the crack will either be arrested (if a short dent), or progress along the dent until a flap is formed and the tank totally fails (if a long dent).

While the primary cause of this increased stress is a rise in internal pressure, dynamic loadings incurred during re-railing operations (such as dropping or twisting the car) could induce stresses sufficient to cause crack propagation. Computer modeling suggests that normal lifting, in and of itself, is generally not a critical factor.



## 5.0 INSPECTING A TANK CAR FOR DAMAGE

Before wreck clearing operations begin, it is imperative that all pressure tank cars be inspected for damage whether they are loaded or empty (many “empty” cars are shipped with relatively high vapor pressures). The following steps should be taken when inspecting damaged tank cars:

- Inspect all accessible areas of the tank for cracks, scores, gouges, wheel burns, dents, and rail burns. Be certain to record the location, size, and other discerning information on the worksheet provided, so that details are not forgotten or overlooked. Any damage that runs in the longitudinal direction (parallel to the long axis of the car) is potentially serious because of hoop stresses. Since that portion of the tank that is lying on the ground may have sustained the most serious damage, it is advisable to have the car lifted in order to properly inspect the underneath portion of the tank. This is particularly advisable if the terrain is rough or if there is reason to believe the tank may have slid across a rail or other obstruction.

Since many pressure cars are jacketed, it is important to differentiate between superficial damage and actual tank damage. Minor dents, scores, or gouges on the tank jacket are not a concern. However, when the jacket is torn or dented for several inches or more, it may be a cause for concern. A rough estimate of the depth of a dent in a jacketed car can be made if one knows the thickness of the jacket material plus the thickness of the insulation and/or thermal protection. If in doubt, the jacket material can be cut away by mechanical means (e.g., air chisel) if it has been determined that there is not a flammable atmosphere present. Some cars are equipped with as much as 4 inches of insulation while others have as little as 1 or 2 inches. The tank car jacket is about 1/8 inch thick.

- Measure the depth of each score, gouge, or wheel burn on the tank.
- Identify the location where each score, gouge, or wheel burn crosses a weld.
- Where a score, gouge, or wheel burn crosses a weld, measure the depth of weld metal removed. If only the crown of the weld reinforcement is removed, the damage is not serious.
- Where a score, gouge, or wheel burn crosses a weld, determine if the heat-affected zone has been damaged. If a score or gouge damages the heat-affected zone, the damage is potentially critical.

**Note: Dents 7 feet or longer that run longitudinally and cross a circumferential weld (girth weld), are particularly critical.**

- Identify those dents which have scores or gouges associated with them and those crossing a weld.

**Note: Dents in combination with scores or gouges and/or dents that cross welds are the most dangerous.**

- Examine each dent or rail burn for cracks and record any found, regardless of size. Relatively large cracks (macro-cracks) are visible to the naked eye. To find smaller cracks (micro-cracks) a magnifying glass will be required. Often, the

loading will weep through even a small crack, so look for signs of frosting or clear liquid near the damaged area.

- Determine the temperature of the tank metal.

**Note: This can be accomplished by attaching a thermometer to the shell of the tank. Ensure that the thermometer is attached to the tank and not the jacket.**

- If any potentially serious damage is found, determine the internal pressure of the car. This is essential for deciding whether the tank should be picked up, unloaded where it is, or another emergency product removal method should be employed.

The pressure may be obtained by either:

- Attaching a pressure gauge to the sample line or spew-type gauging device (both these fittings are usually 1/4 inch and will not require reducers). If the car is not equipped with a sample line or gauging device (e.g., a chlorine car), reducers must be used to accommodate the differential between the liquid or vapor valve to the gauge. Depending on the orientation of the car, it is often helpful to attach a long hose of appropriate pressure rating to the gauge so that the gauge hangs down the side of the car. This eliminates the need to climb up and down each time a reading is required.
- Taking the temperature of the contents and referring to the vapor pressure/temperature graphs for the particular product.

**Notes:**

- Graphs are available from the Compressed Gas handbook (see Appendix C), the shipper, or the manufacturer of the commodity.
- Most pressures are shown as pounds per square inch absolute; therefore, 14.7 must be subtracted to obtain gauge pressure.
- In the event that neither temperature nor pressure can be measured, a rough estimate of the temperature of the product can be made from ambient temperature. The temperature of the tank's contents may lag ambient temperature by about 6 hours (for a non-insulated or thermally protected car). Since the contents of a tank car may stratify by temperature, taking a direct pressure reading is the preferred method.
- Keep in mind that the internal pressure of "residue" tank cars containing the vapors of residual products may be equal to or higher than that in loaded cars.
- If any potentially serious damage to the car is found, the next step is to determine the year the car was built in order to identify what the material of construction is. The built date of a tank car can be determined from the consolidated stencil located on the right end of the car toward the bottom while one is facing the car. The abbreviation "BLT" followed by a year generally denotes the built date (example: BLT '67). This information is helpful because post-1967 cars are built of better steel. The type of steel used to construct the tank is also stamped into the head of the tank car.

## 6.0 REVISED DAMAGE ASSESSMENT GUIDELINES

When inspecting a damaged tank car, the inspector must be able to identify and categorize various types of tank damage. This section defines, illustrates, and explains how to interpret the seriousness of the following types of damage:

- Cracks
- Scores
- Gouges
- Wheel burns
- Dents
- Rail burns
- Long dents (7 feet or longer)

Accurate assessment of damage on jacketed tanks is difficult without removing the jacket and thermal protection/insulation. There is often great reluctance to use mechanical means to cut away the jacket of a damaged car for fear of explosion. However, this procedure can be performed safely if the area is carefully monitored for combustible gases.

**Note:** Tank cars in classes 105, 112J, 114J, and 120 are jacketed. Tank cars in classes 112A, 112S, 112T, 114A, 114S, and 114T are not jacketed cars.

Although damage to the jacket of a car is of no consequence, serious jacket damage may be an indication of tank damage behind the jacket.

### 6.1 Cracks

As illustrated in Figure 2, a crack is a narrow split or break in the tank metal, which may or may not penetrate through the tank metal. Cracks may be microscopic or macroscopic (visible to the naked eye).

- Since there is no way to detect a crack that has become critical, a crack found anywhere in the base metal or weld of a tank is justification for unloading the car in place.
- Cracks in attachment pads or the welds of these pads are not serious unless they extend into the base metal of the tank. **Caution:** Cracks have been found recently in heads of certain tanks equipped with head blocks.
- Cracks, which run longitudinally to the long axis of the car, are at least 50-75 percent more serious than those that are perpendicular to the long axis.
- Cracks in conjunction with other types of damage are more serious than if found alone (e.g., a crack in the valley of a dent).

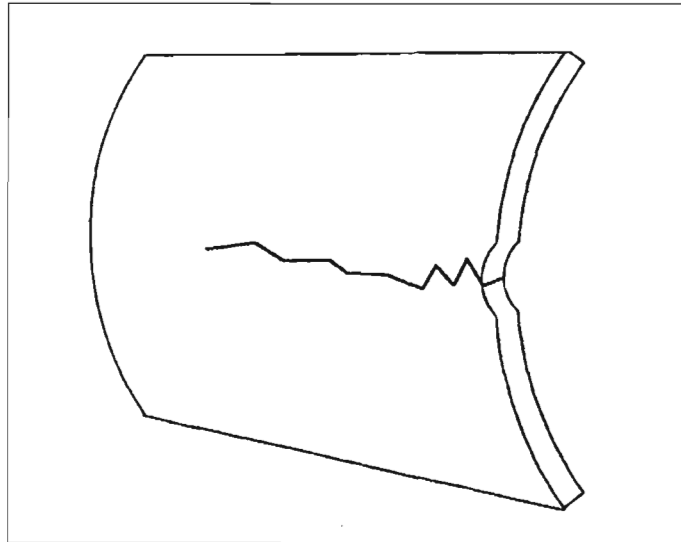
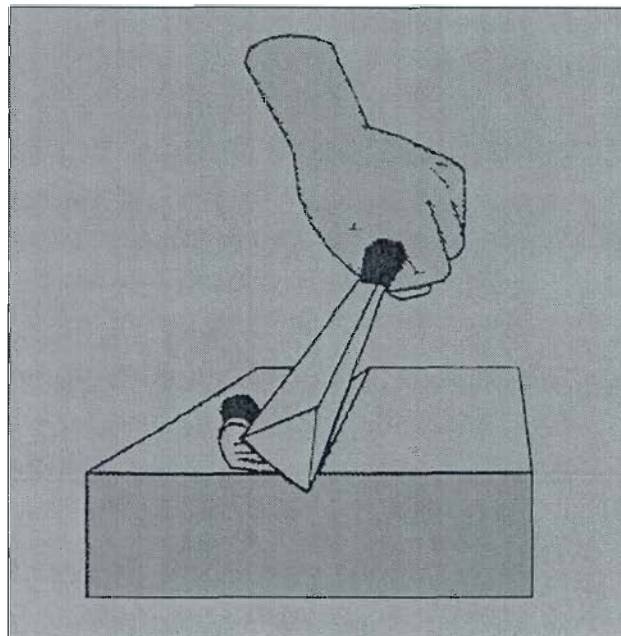

**Figure 2. Illustration: Crack in the Tank Metal**

## **6.2 Scores**

A score is a relocation of tank or weld metal so that the metal is pushed aside along the track of contact with another object. This causes a reduction in tank metal thickness. Scores and gouges in conjunction with dents are discussed in Section

Scores or gouges crossing a weld and removing only the weld reinforcement (crown) are not critical (see Figure 3).



**Figure 3. Illustration: Score**

421

Longitudinal scores are the most dangerous. However, circumferential scores cannot be ignored for at any given section such scores also constitute a longitudinal notch.

As shown in Figure 4, longitudinal scores or gouges crossing welds and damaging the heat-affected zone(s) are critical and the contents of the tank should be transferred immediately without raising the internal pressure of the tank (see various transfer methods in *Field Product Removal Methods For Tank Cars*).

Tanks having scores or gouges should have their internal pressure reduced or be unloaded in place when the internal pressure exceeds the pressure listed in Tables 2 and 3. The tables provide the allowable score depths and allowable pressures for 340W and 400W tanks, respectively. These tables incorporate a 2:1 safety factor; that is, the calculated burst pressure is actually twice the value shown in the tables.

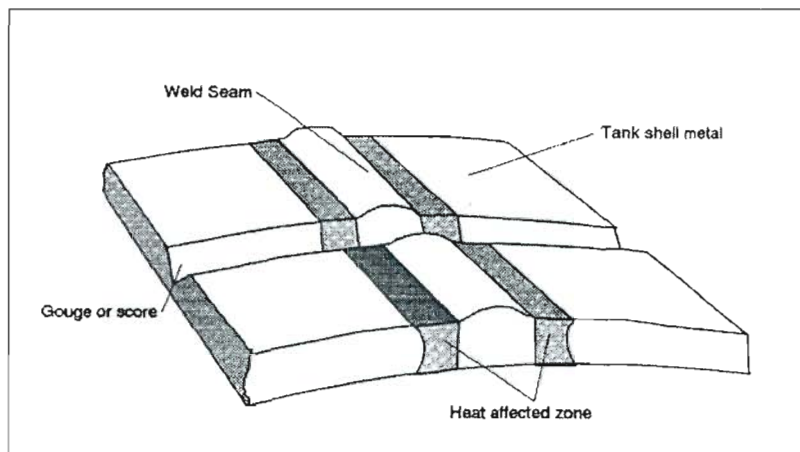

**Figure 4. Illustration of Gouge Crossing the HAZ**

**Table 2. Limiting Score Depths for 340W Tanks**

PSIG = pounds per square inch gauge

Depth of Score	Maximum Safe Internal Pressure,
1/16 inch	191 PSIG
1/8 inch	170 PSIG
3/16 inch	149 PSIG
1/4 inch	127 PSIG

Note: The bursting pressure for a 340W tank is 850 psi (in the newly constructed, undamaged condition.)

**Table 3. Limiting Score Depths for 400 W Tanks**

PSIG = pounds per square inch gauge

Depth of Score	Maximum Safe Internal Pressure, PSIG
1/16 inch	228 PSIG
1/8 inch	205 PSIG
3/16 inch	188 PSIG
1/4 inch	162 PSIG

Note: The bursting pressure for a 400W tank is 1,000 psi (in the newly constructed, undamaged condition.)

412

Both tables above assume the minimum tank thickness prescribed by current Federal regulations.

The decision to immediately reduce internal pressure or unload the car in place must be based upon the internal pressure of the tank and relating that number to the maximum safe internal pressures in the tables above. For example, if a 400W tank has a 1/4-inch deep score, and the internal pressure is 160 psi (after correcting for gauge pressure), the tank car can be safely moved. It is important to remember that this guideline assumes no other damage associated with the score.

### 6.2.1 Calculating Minimum Tank Thickness

CFR 49, Section 179.100-6 (a), sets the minimum thickness for pressure tank car tanks. The formula for calculating tank thickness is as follows:

$$T = \frac{PD}{2SE}$$

Where:

T = Minimum Thickness of Plates After Forming

P = Pressure (Burst)

D = Diameter

S = Minimum Tensile Strength of plate material

E = Welded Joint Efficiency = 1.0

Therefore, the following is the equation that would be used to determine the minimum required thickness for a DOT 112J340W tank car with an interior diameter of 118 1/4 inches, constructed of TC-128B steel, of 81,000 psi tensile strength:

$$T = \frac{PD}{2SE} = \frac{850 \times 118.25}{2 \times 81,000 \times 1.00} = .6204$$

The minimum thickness of this tank will be .6204 inch

### 6.2.2 Calculating Safe Internal Pressure

To calculate the safe internal pressure of a car with a longitudinal gouge 1/4 inch deep, we rearrange the formula in this manner.

$$P = \frac{T2SE}{D} = \frac{.3704 \times 2 \times 81,000 \times 1}{118.25} = 507 \text{ (bursting pressure)}$$

To maintain a safety factor of 2, divide the calculated burst pressure by two:

$$507 \text{ divided by } 2 = 253.5 \text{ (maximum safe internal pressure)}$$

Note that this calculation assumes no damage other than reduced thickness of the tank.

(44)

### 6.3 Gouges

A gouge is a removal of the tank or weld metal along the track of contact with another object (Figure 5). This causes a reduction in tank metal thickness.

For the purpose of this report, gouges are treated in the same manner as scores. That is, unless associated with other types of damage, a gouge just reduces the thickness of the tank, and the same evaluation process is used.

### 6.4 Wheel Burns

As shown in Figure 6, a wheel burn is similar to a gouge but is caused by prolonged wheel contact with the tank, which often causes metal discoloration and potential metallurgical damage. The discoloration itself does not cause serious damage.

### 6.5 Dents

Figure 7 depicts a dent, which is a deformation that changes the tank's contour from that of original manufacture as a result of impact with a relatively blunt object (coupler, draft sill, or the end of an adjacent car).

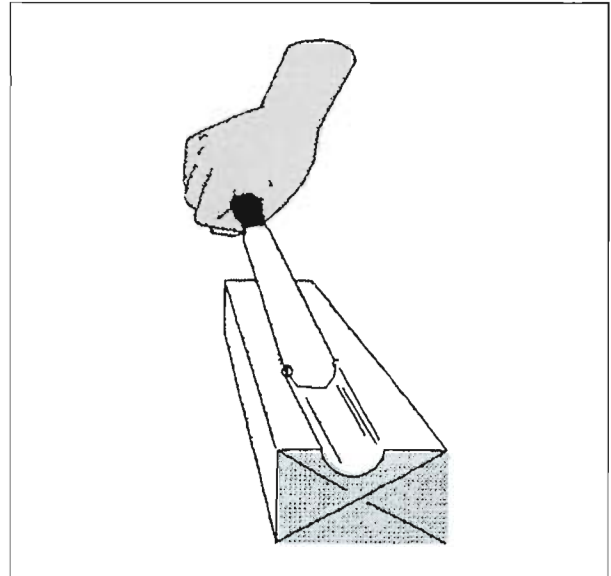

Figure 5. Illustration: Gouge

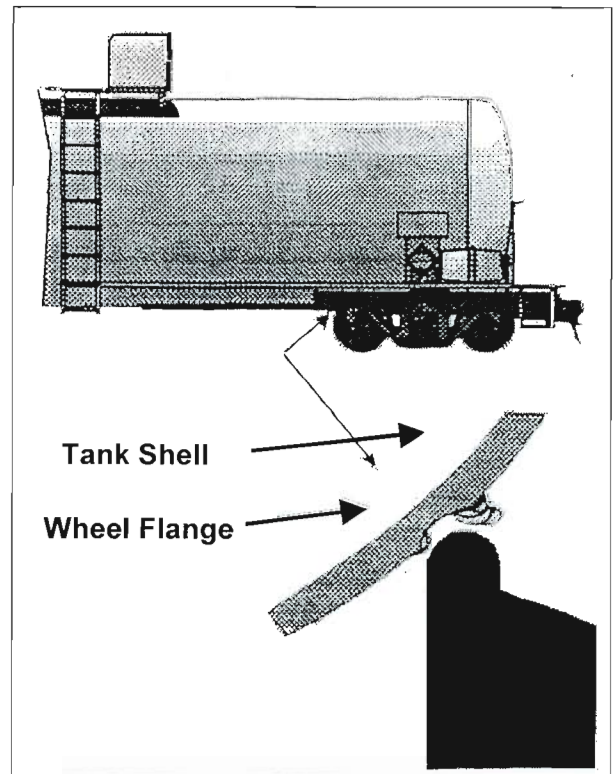

Figure 6. Illustration: Wheel Burn

45

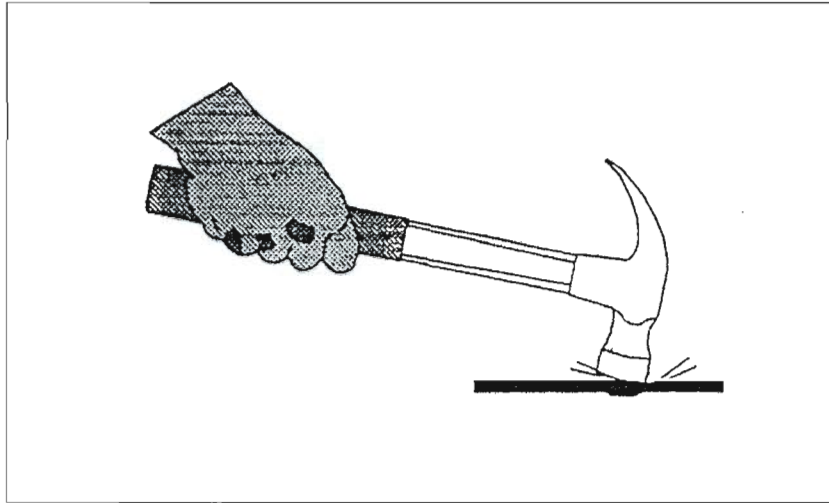

Figure 7. Illustration: Dent

### 6.5.1 Rail Dents

A rail dent is a long dent, usually parallel to the length of the tank (i.e., parallel to the longitudinal axis of the tank) that crosses a weld and causes cold work (Figure 8). The tank falling on, or passing over a stationary object such as a rail generally causes it. Rail dents are sometimes referred to as rail burns when the sliding action of the tank over the rail produces a discoloration of the surface metal. This surface discoloration (burn) is superficial and is not serious.

The guidelines give a safety factor of 3 (i.e., the maximum strain allowed by the guidelines is one-third of the minimum value for that material).

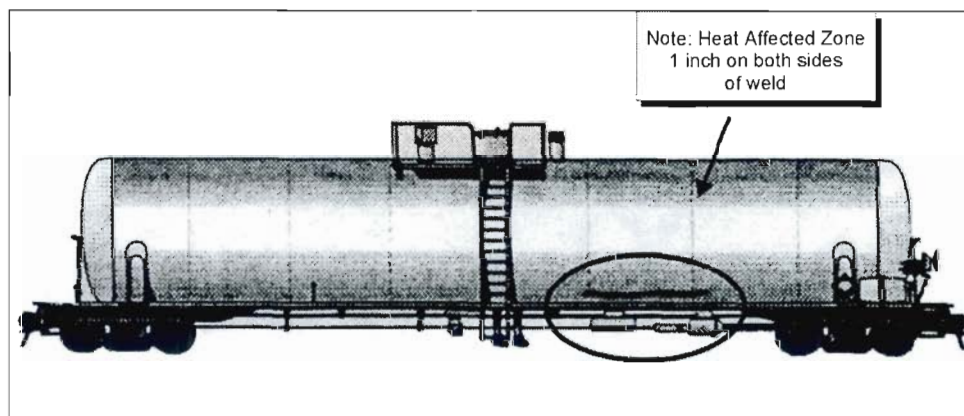

Figure 8. Rail Dent



In considering the severity of dents, the following factors need to be addressed:

- The internal pressure of the tank.
- The length of the dent -- long dents are more serious than short dents. Catastrophic failure has never occurred unless the dent was 7 feet or longer.
- The location of the dent -- dents that cross welds of any kind or touch the heat-affected zone of any weld are the most serious. Note: for the purposes of this report, the heat-affected zone is defined as within 1 inch of either side of a weld bead.
  - Sharp dents in the cylindrical portion of the tank which are parallel to the long axis and cross a weld are the most serious as they can drop the rated burst pressure of the tank by 75 percent (from 850 psi to 212 psi) for a 340-psi tank.

**Note:** Every catastrophic delayed failure of a pressure car has been associated with dents of this type that were 7 feet in length or longer. The longer the dent, the more serious it is.

#### **6.5.2 Dents in the Shell of Tank Cars Built Before 1967**

The tank should be unloaded without moving if it meets any of the following conditions:

- Has a crack anywhere
- Crosses a weld; or touches a heat-affected zone
- Includes a score or gouge

Dents which do not cross a weld, touch a heat-affected zone, and are not associated with any other damage are not a problem by themselves.

#### **6.5.3 Dents in the Shell of Tank Cars built in 1967 and After**

The tank should be unloaded without moving if it meets any of the following conditions:

- Has a crack anywhere
- Crosses a weld or touches a heat-affected zone
- Includes a score or gouge
- Shows evidence of cold work

#### **6.5.4 Massive Dents**

Massive dents in heads of the tank are generally not serious unless gouges or cracks are present with the dent.

#### **6.5.5 Small Dents**

Small dents in heads, in conjunction with other damage in the bottom of the dent, are marginal. If at all possible, such tanks should be unloaded in place. In any case, the tank should be moved as little as possible and promptly unloaded.

## 8.0 DISCUSSION OF RE-RAILING PROCEDURES

Computer modeling studies indicate that when a tank car is lifted properly (i.e., a straight lift from the body bolster or stub sill) the lifting loads imparted into the tank structure will not significantly reduce the safety factors used in evaluating a damaged car. These loads are relatively small relative to the stresses imparted by the internal pressure on the tank exerted by the lading. There are two possible exceptions: 1) when it is a car with critical damage in the area adjacent to the stub sill or bolster; or when a car with a deep (6" or more in this case), long dent is lifted in a way that would cause the dent to flex (Figure 9). This is one case where a circumferential dent can be critical, even when it does not cross a weld.

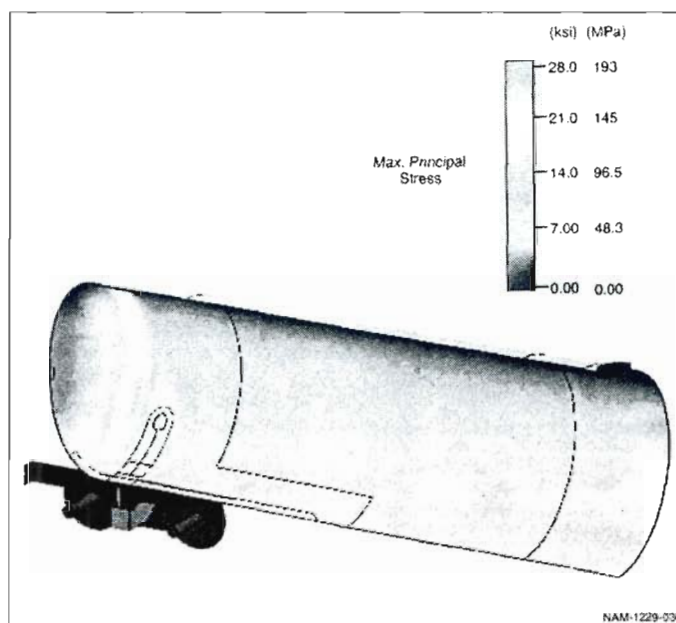

**Figure 9. Maximum Principal Stress Distribution from 130-psi Internal Pressure and Lading**

Lifting a car in this manner tends to:

- Flex the metal making the bend open up more (if the car is sitting upright and the bend runs circumferentially crossing the bottom of the tank), or
- Flex the metal the other direction causing the bend radius to become sharper (if the bend is on the top of the tank).

In either case, the effect is much like that when a metal can is bent into a "V" shape and then bent backwards. It only takes several instances of flex before the can fails, even with no internal pressure.

Care should be exercised when "rolling" severely damaged cars that a "torquing" effect is not created.

**APPENDIX B:  
TANK CAR DAMAGE  
ASSESSMENT WORKSHEET**

(blank)

**TANK CAR DAMAGE ASSESSMENT RECORD**

**Reporting marks:** \_\_\_\_\_

**Built Date:** \_\_\_\_\_

**Specification:** \_\_\_\_\_

**Load / Empty:** \_\_\_\_\_

**Product:** \_\_\_\_\_

**Internal Pressure:** \_\_\_\_\_

**Ambient Temp. At Time of Derailment** \_\_\_\_\_

Damage Type	Length	Depth	In Conjunction with:	Cross a Weld or HAZ? (Y/N)
Crack				
Score				
Gouge				
Wheel Burn				
Dent				
Rail Dent				

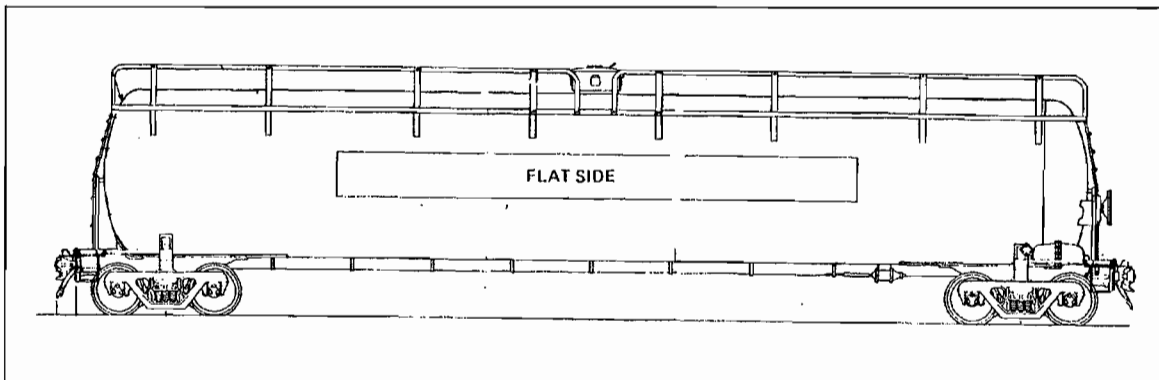

**Pressure Car**

(blank)

**APPENDIX C:  
COMPRESSED GAS TABLES (22)**

(blank)



Ammonia

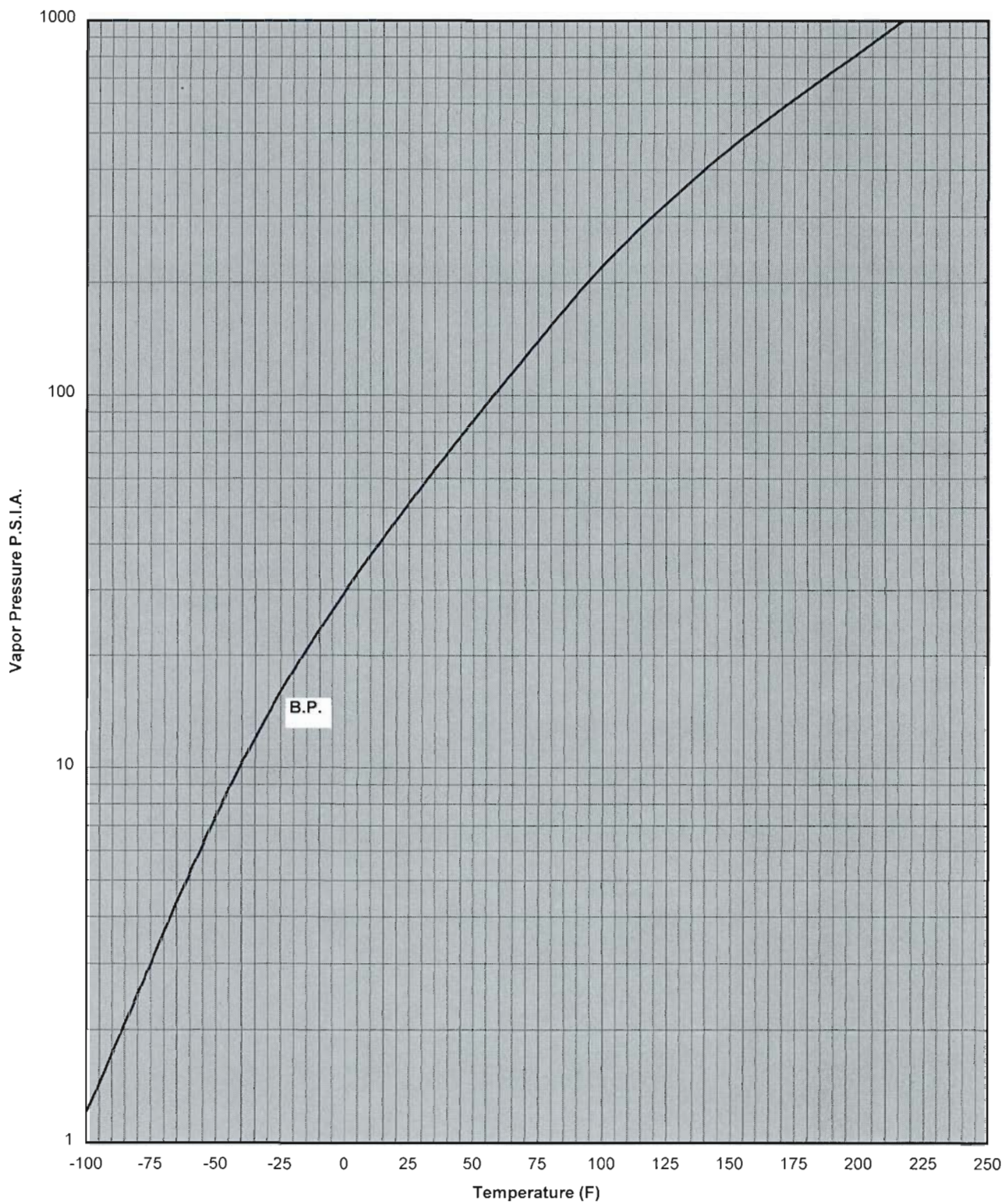

54

Butadiene

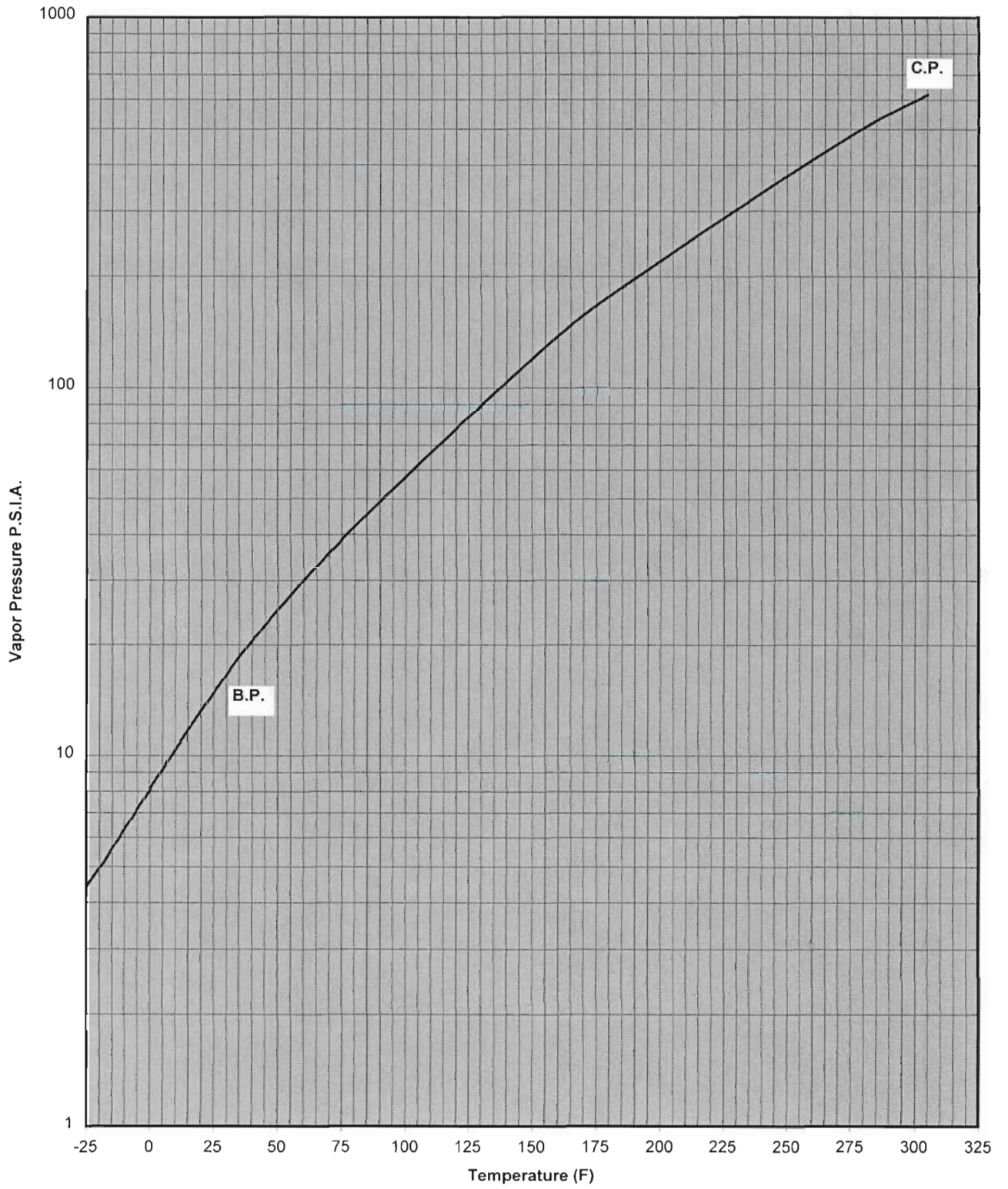

150

n-Butane

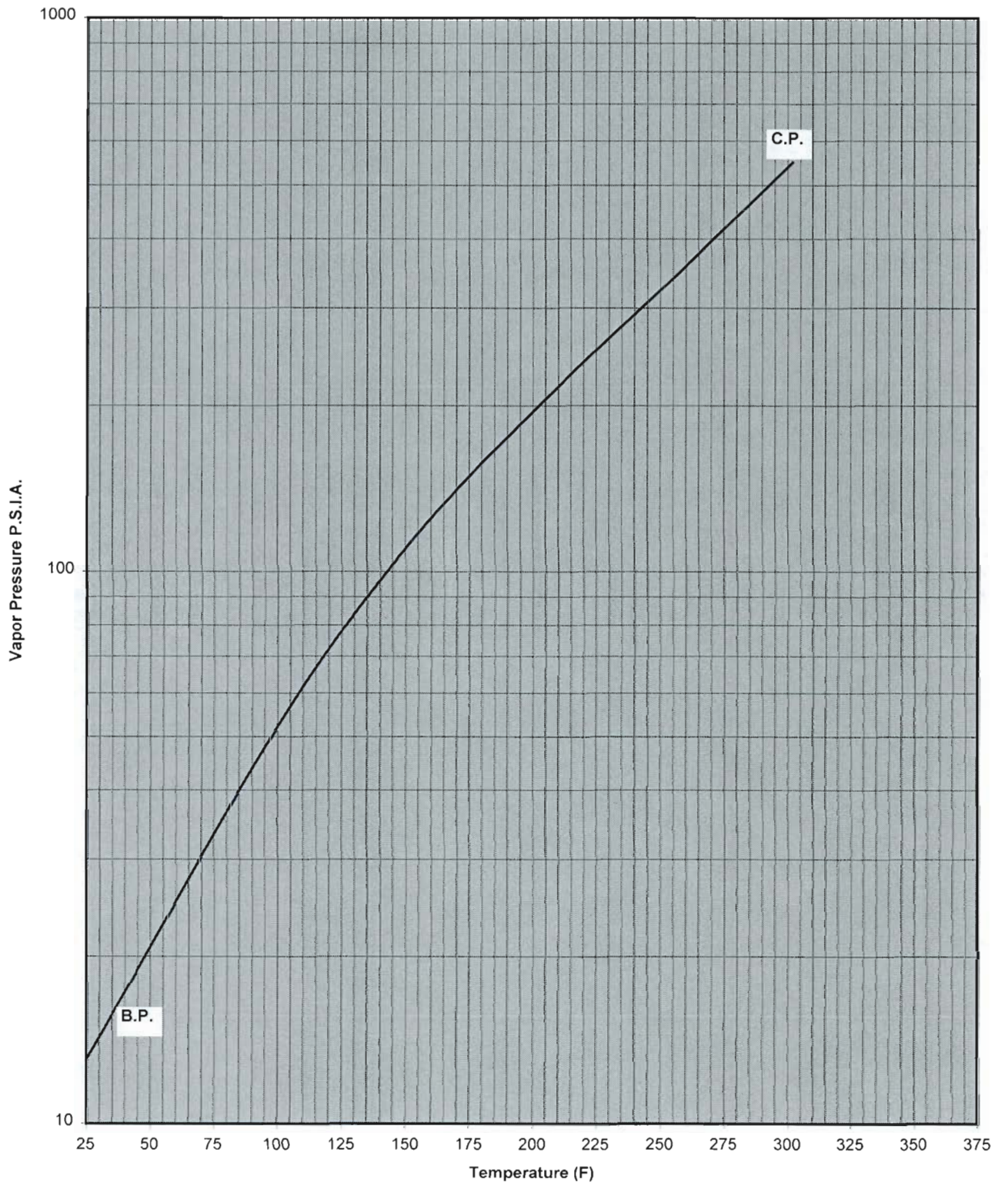

157

# Carbon Dioxide

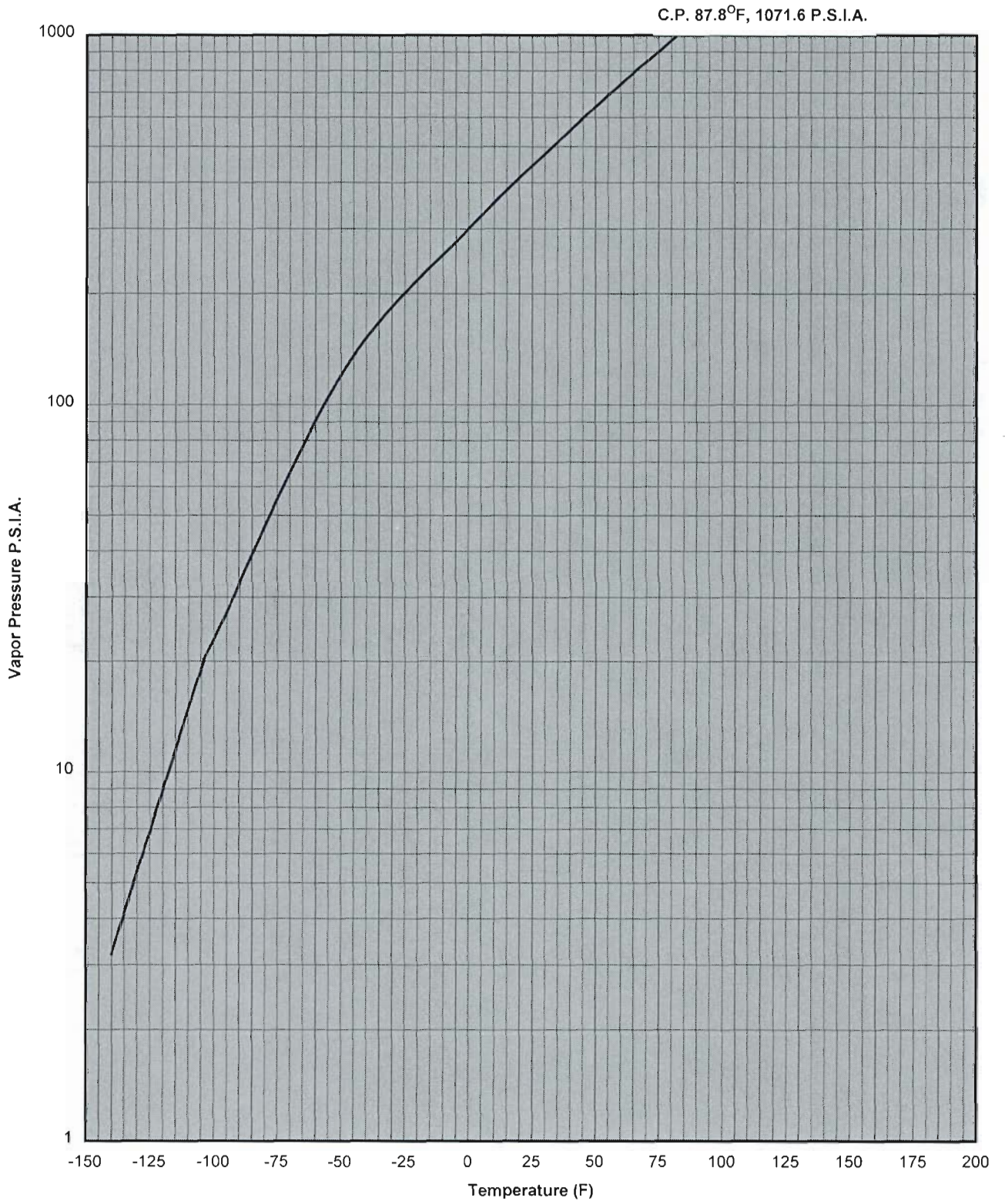

# Chlorine

C.P. 291.2°F, 1118.7 P.S.I.A.

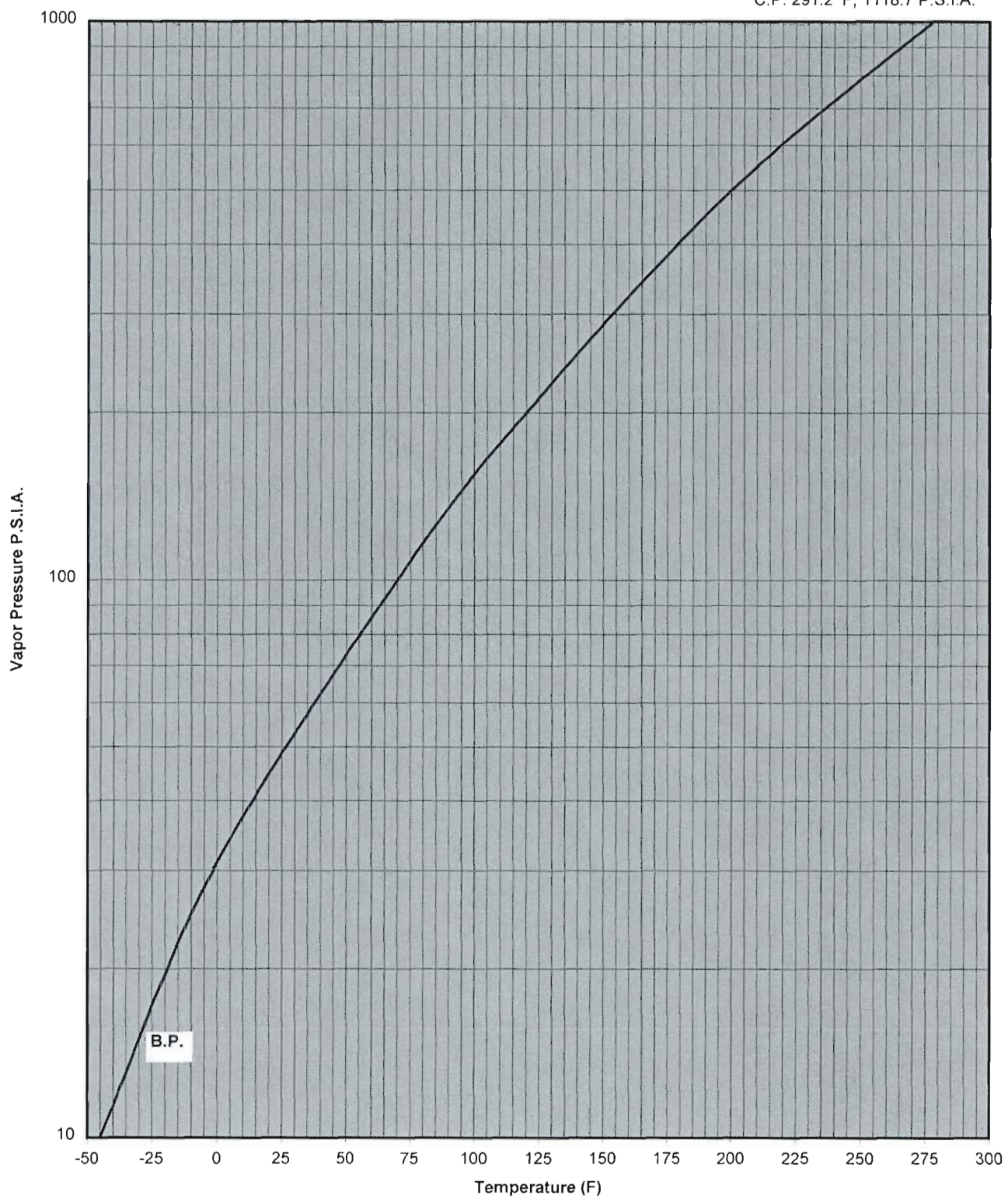

# Chlorodifluoromethane

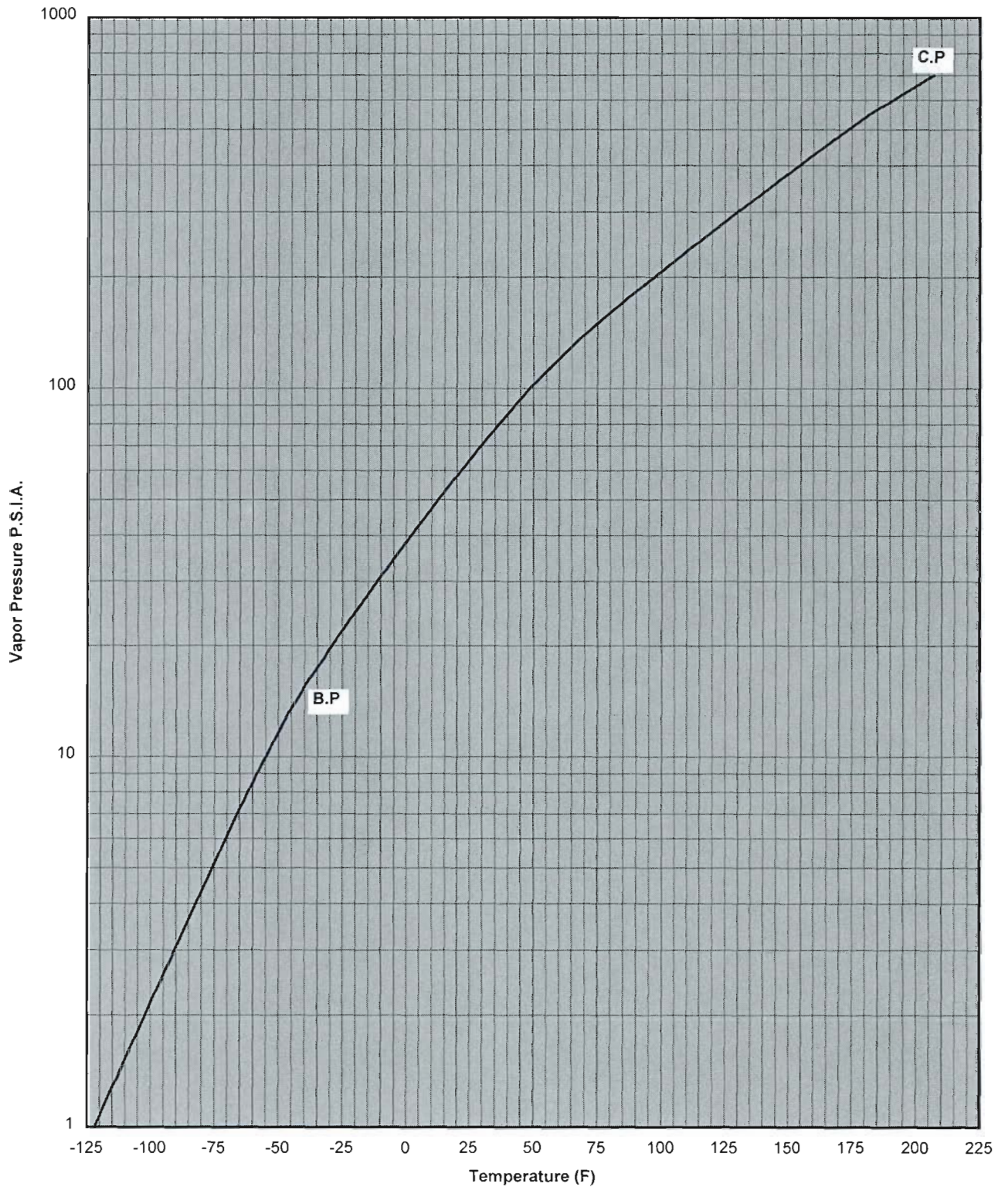

Dichlorodifluoromethane

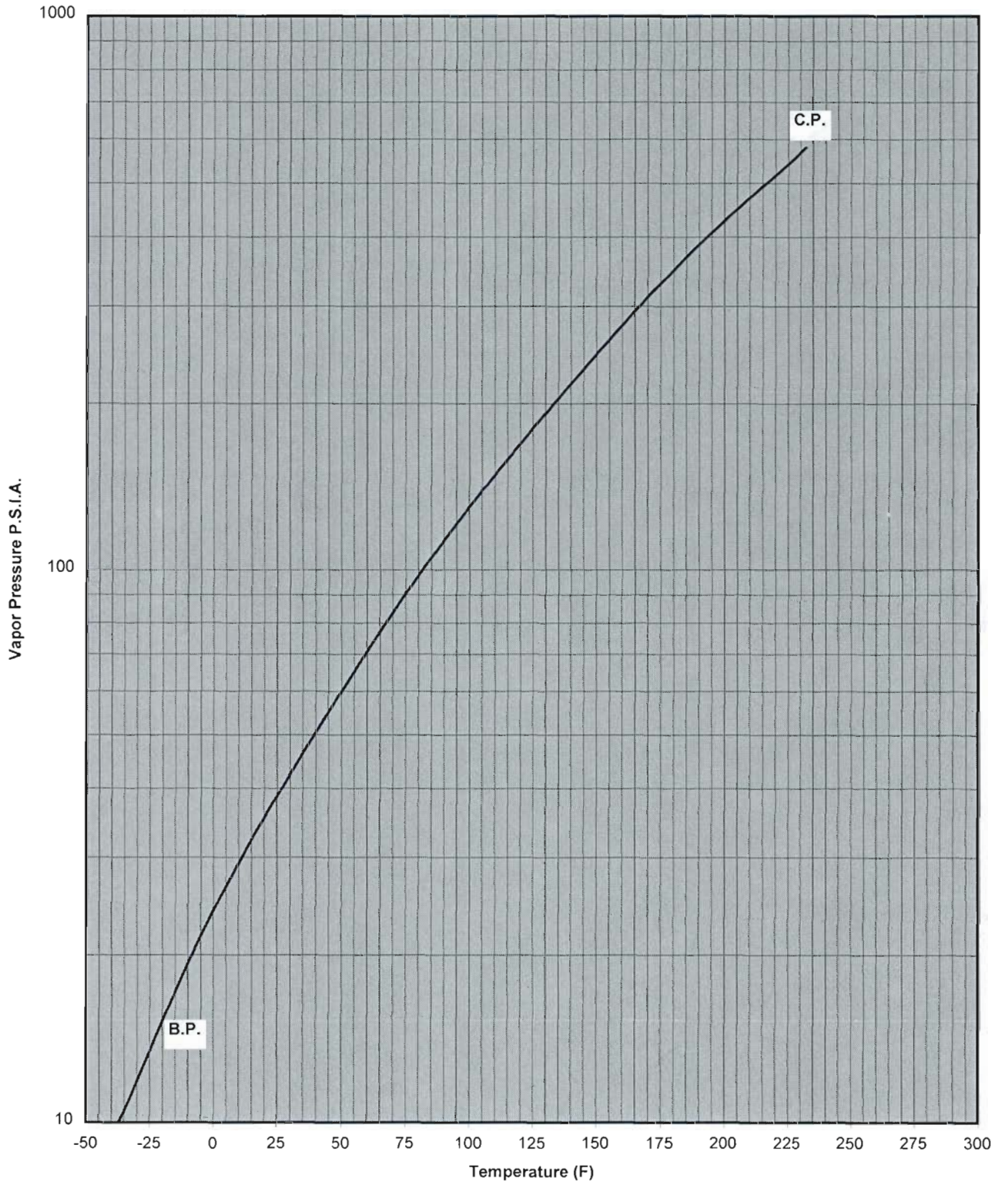

# Dimethylamine

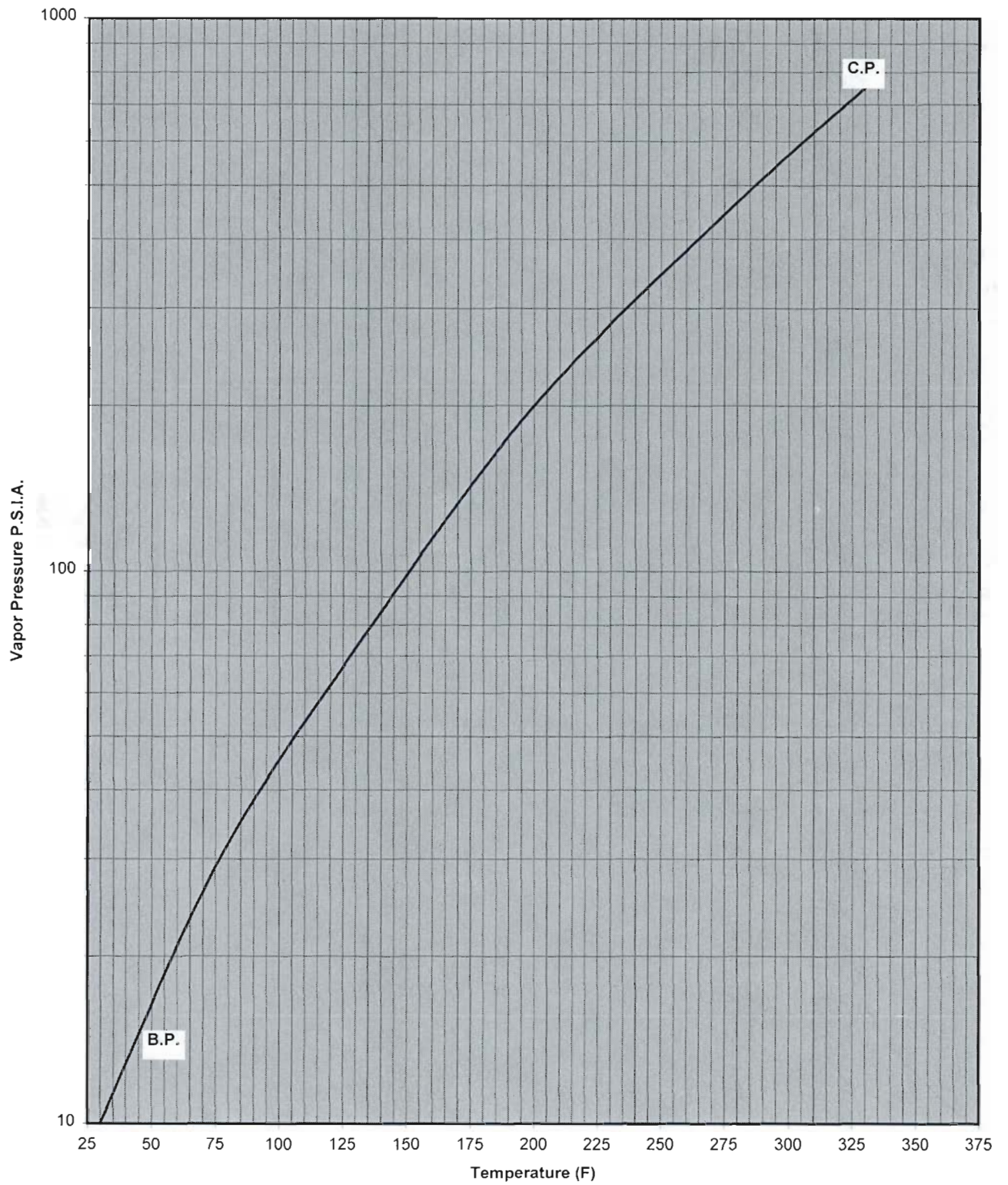

62



# Ethane

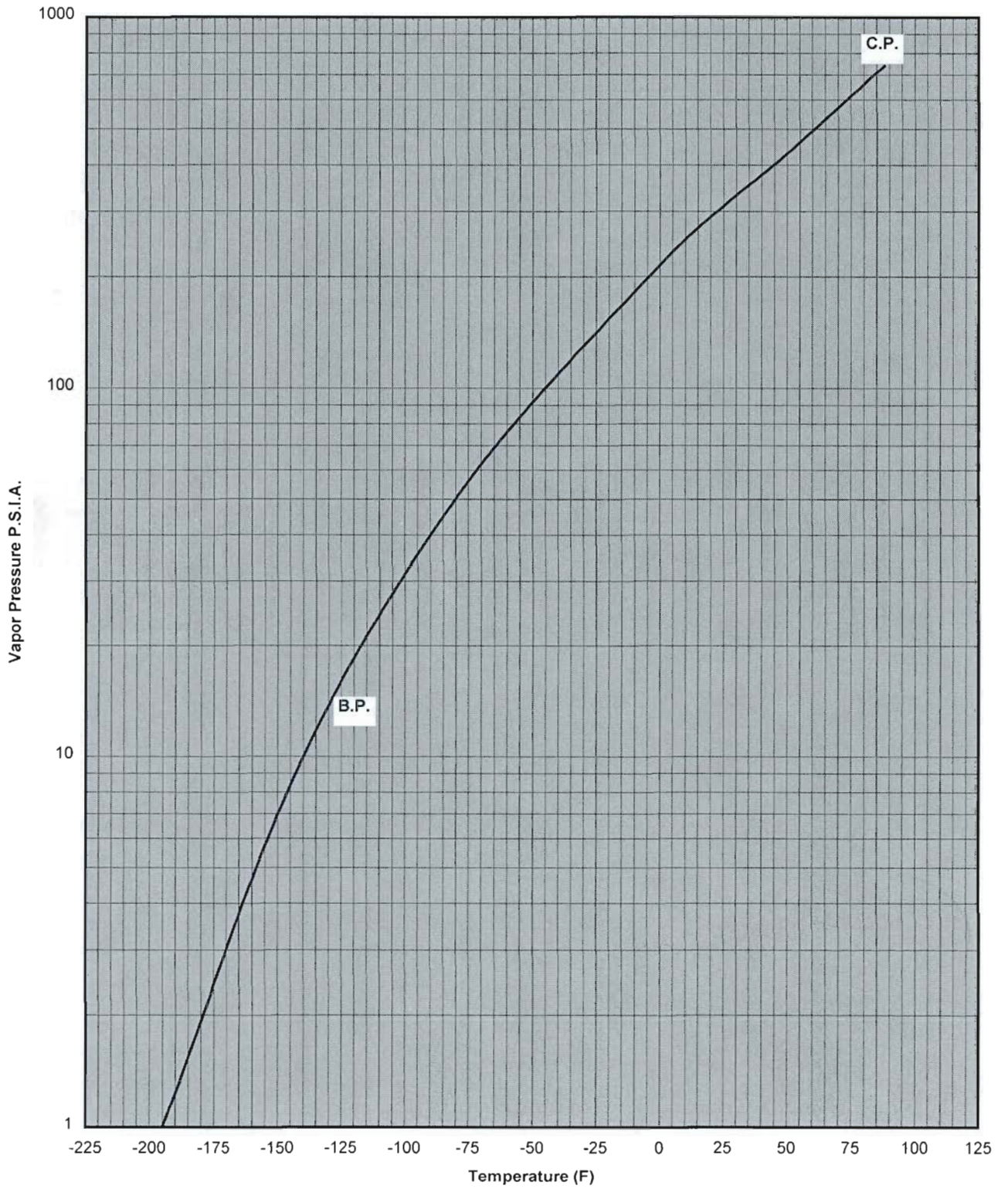

163

# Ethylene

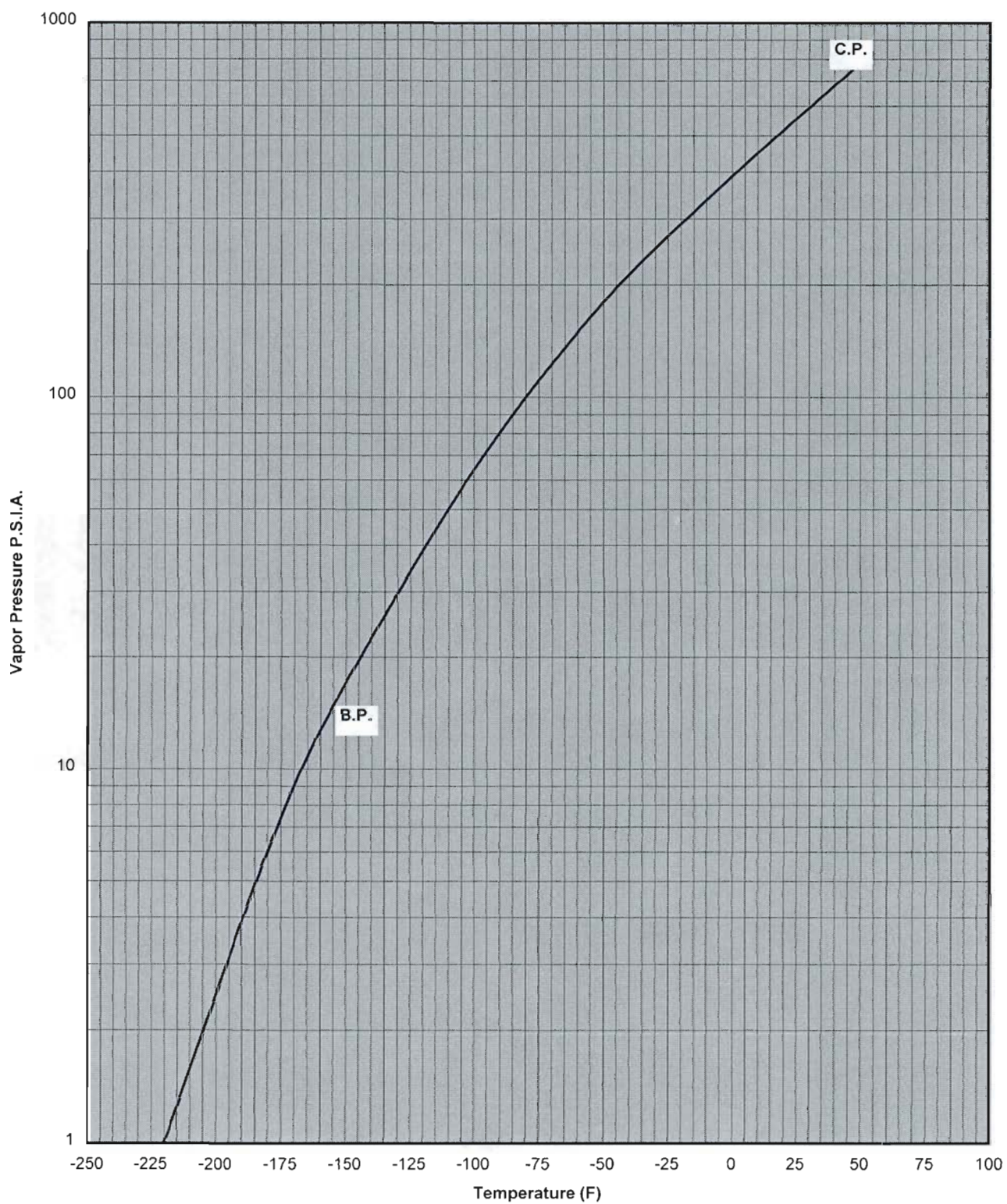

164

# Ethylene Oxide

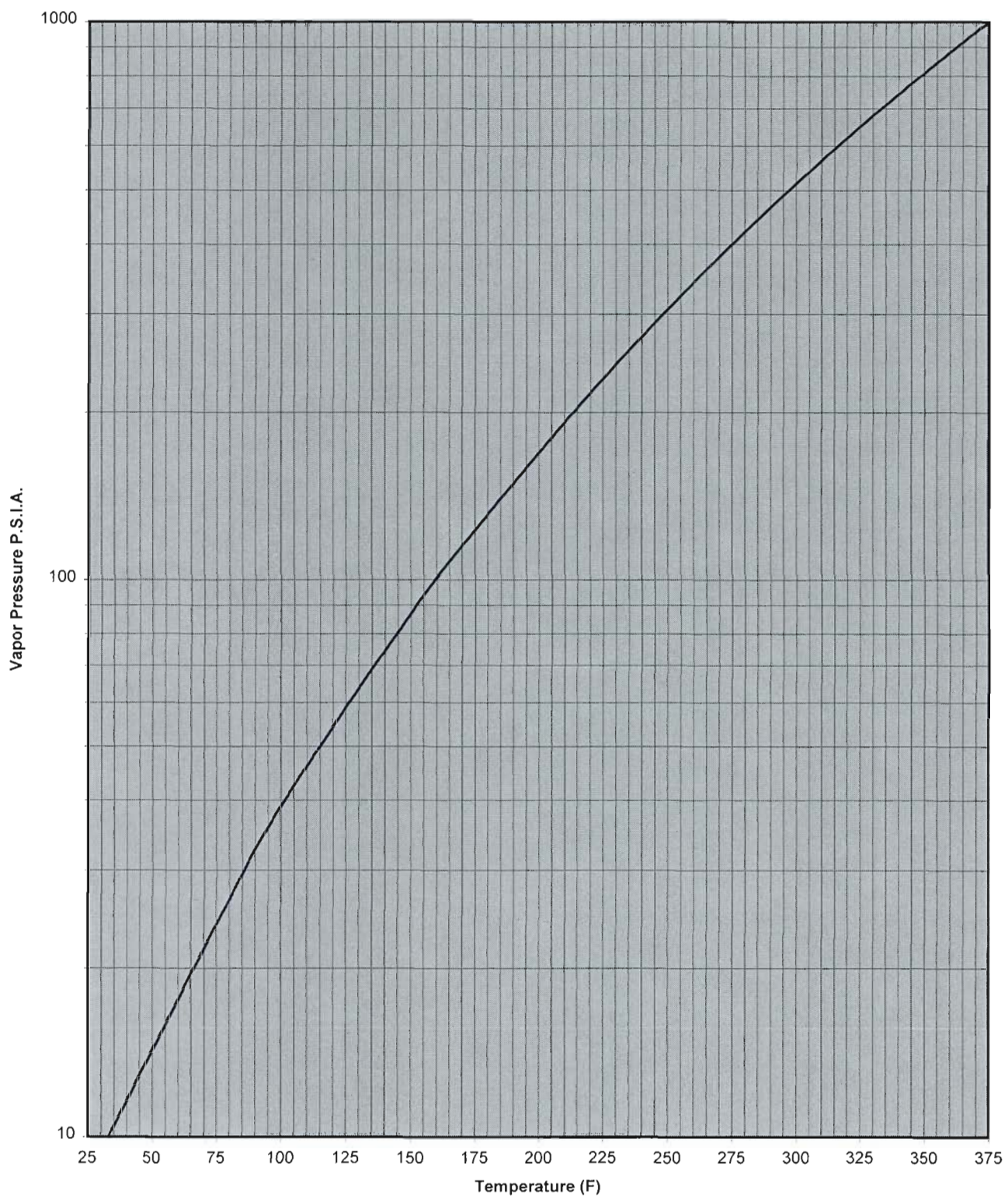

65

# Hydrogen Chloride

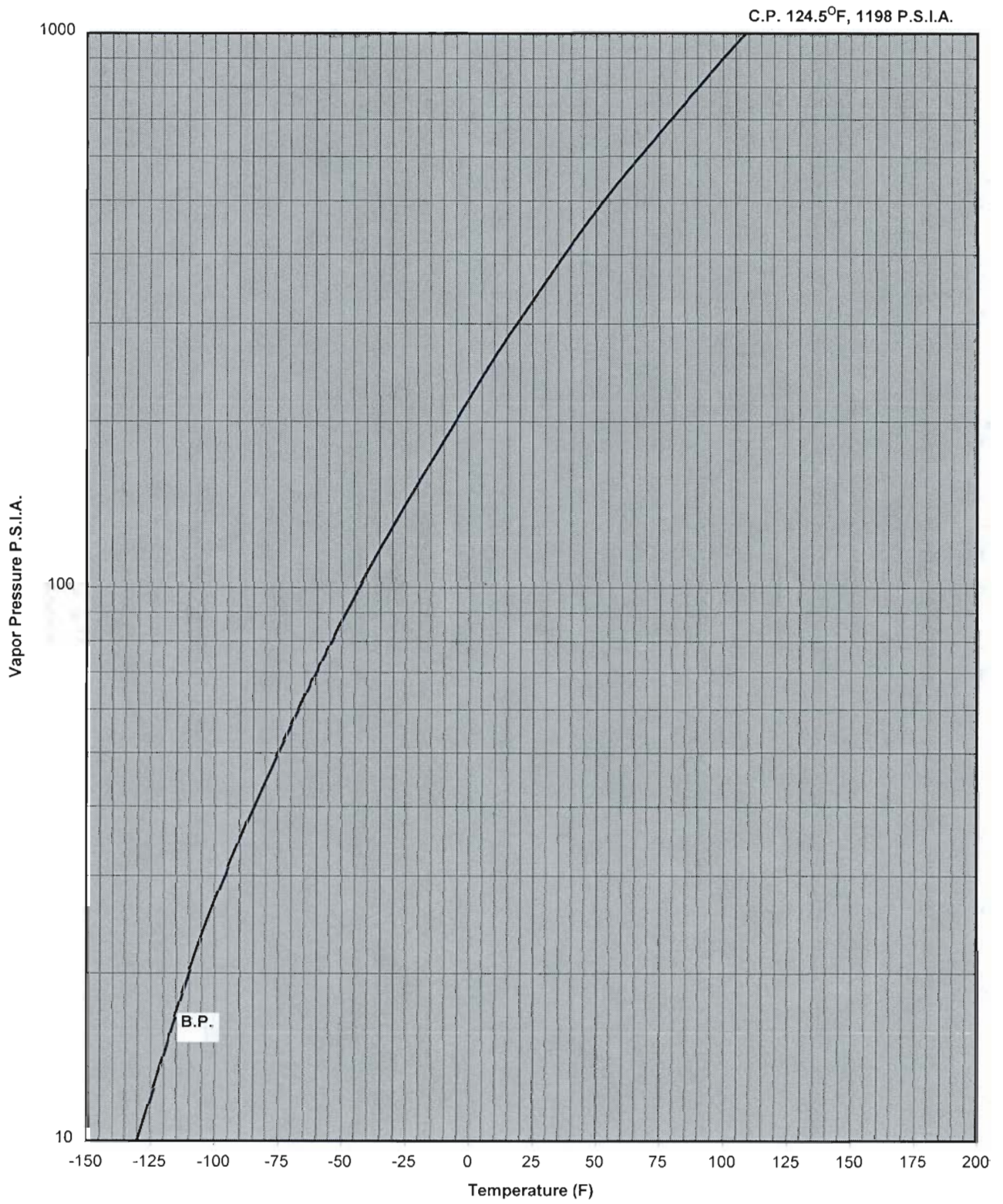

# Hydrogen Fluoride

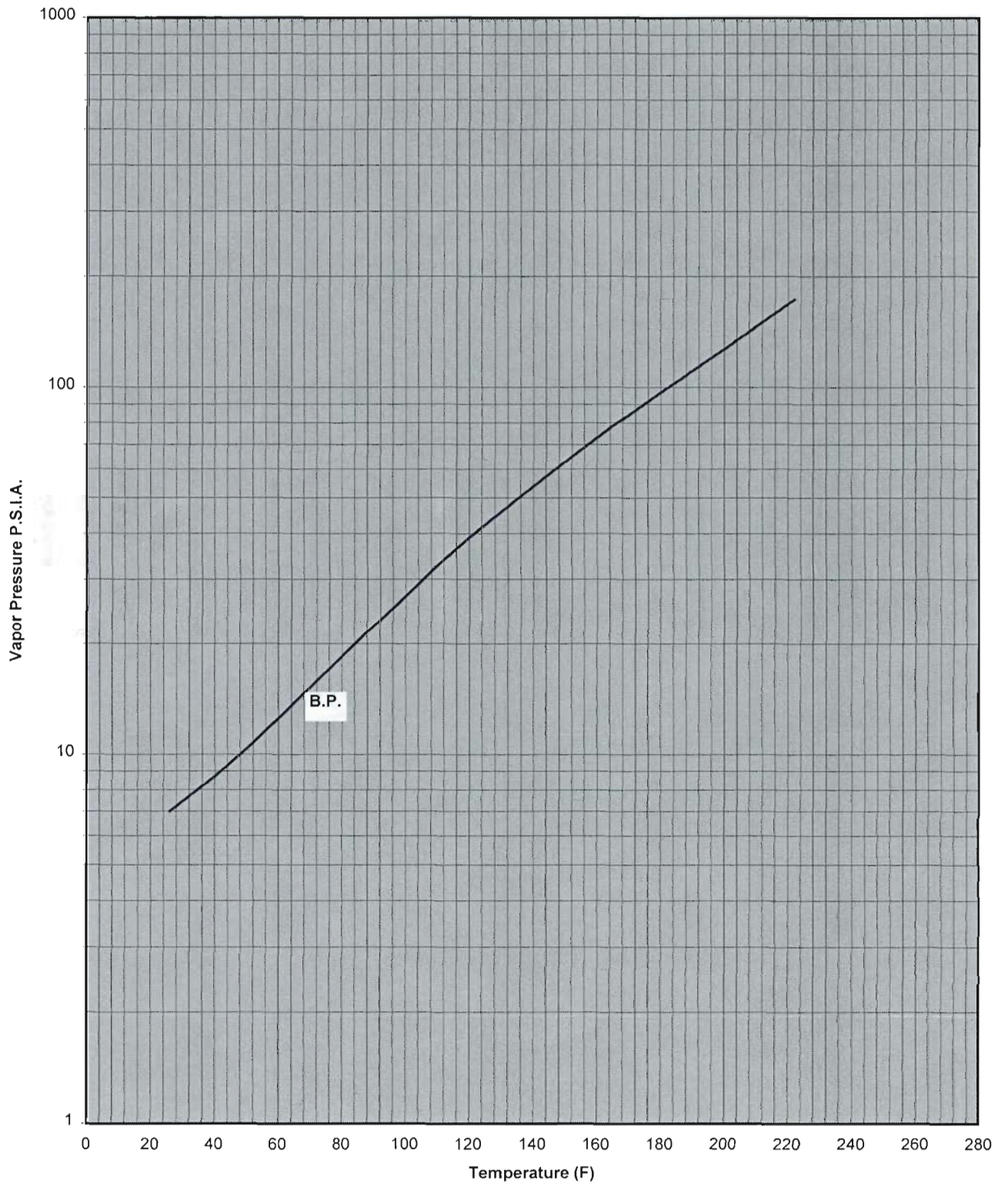

07

# Hydrogen Sulfide

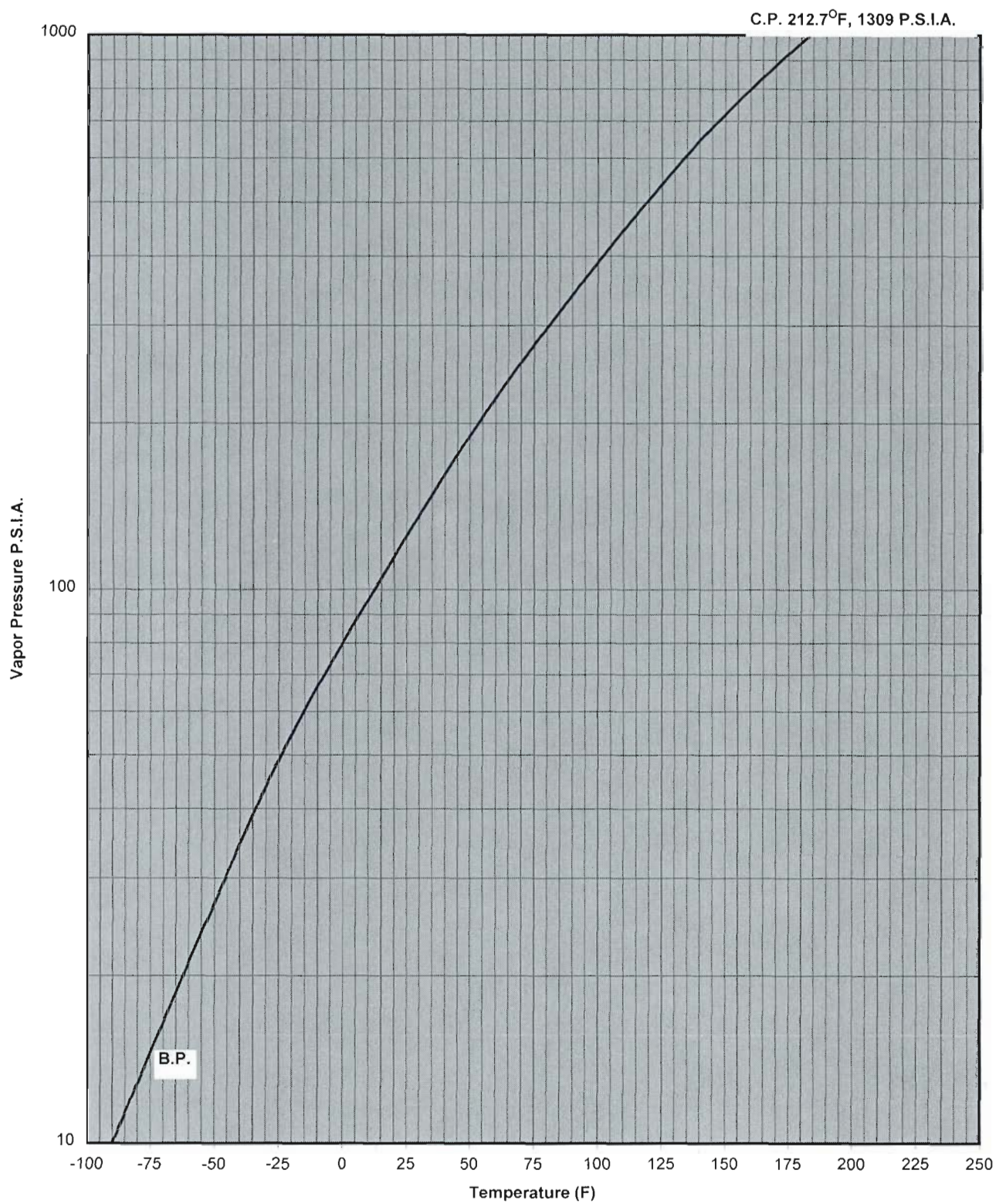

07

# Methyl Chloride

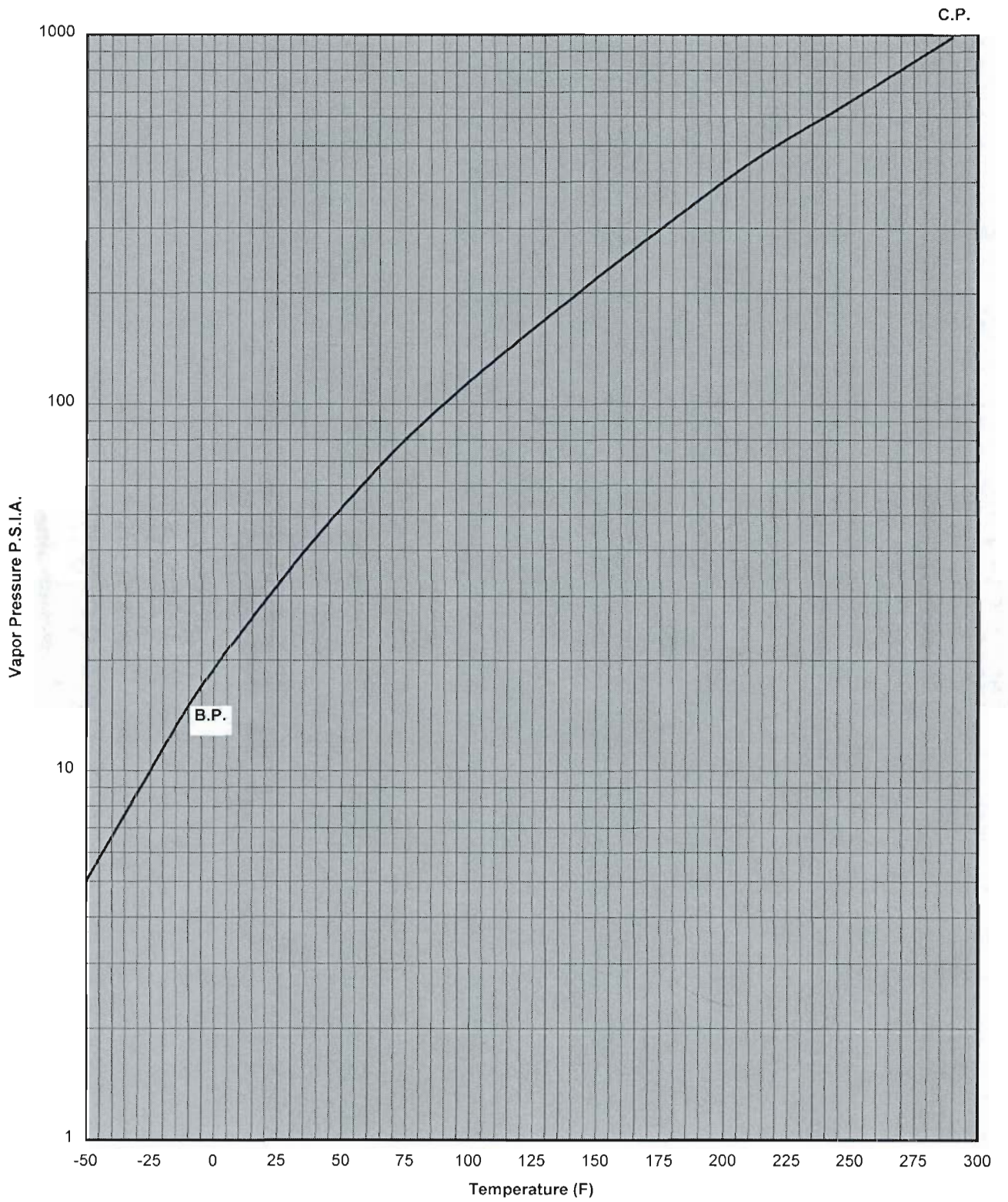

# Isobutane

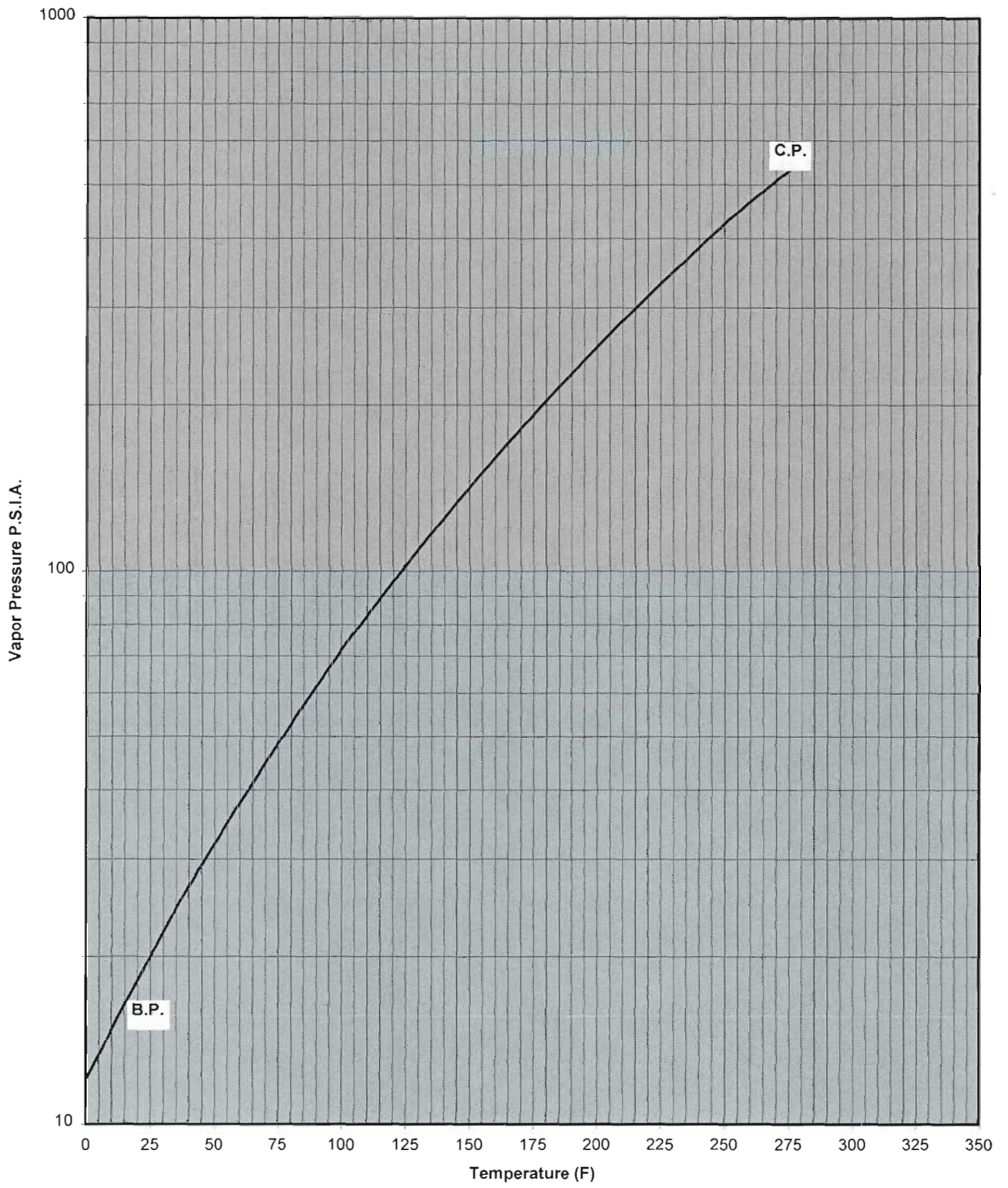

170



# Monomethylamine

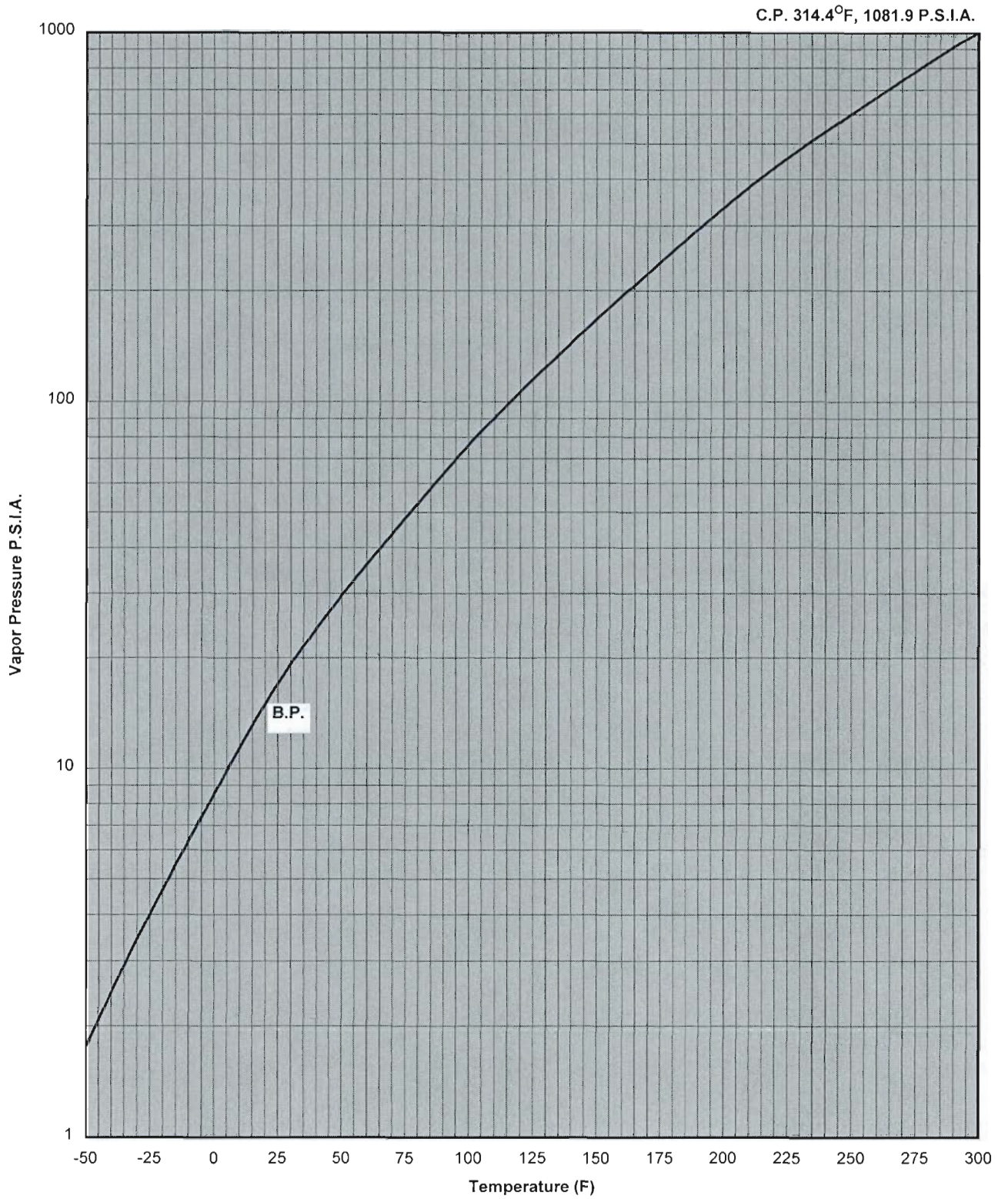

# Propane

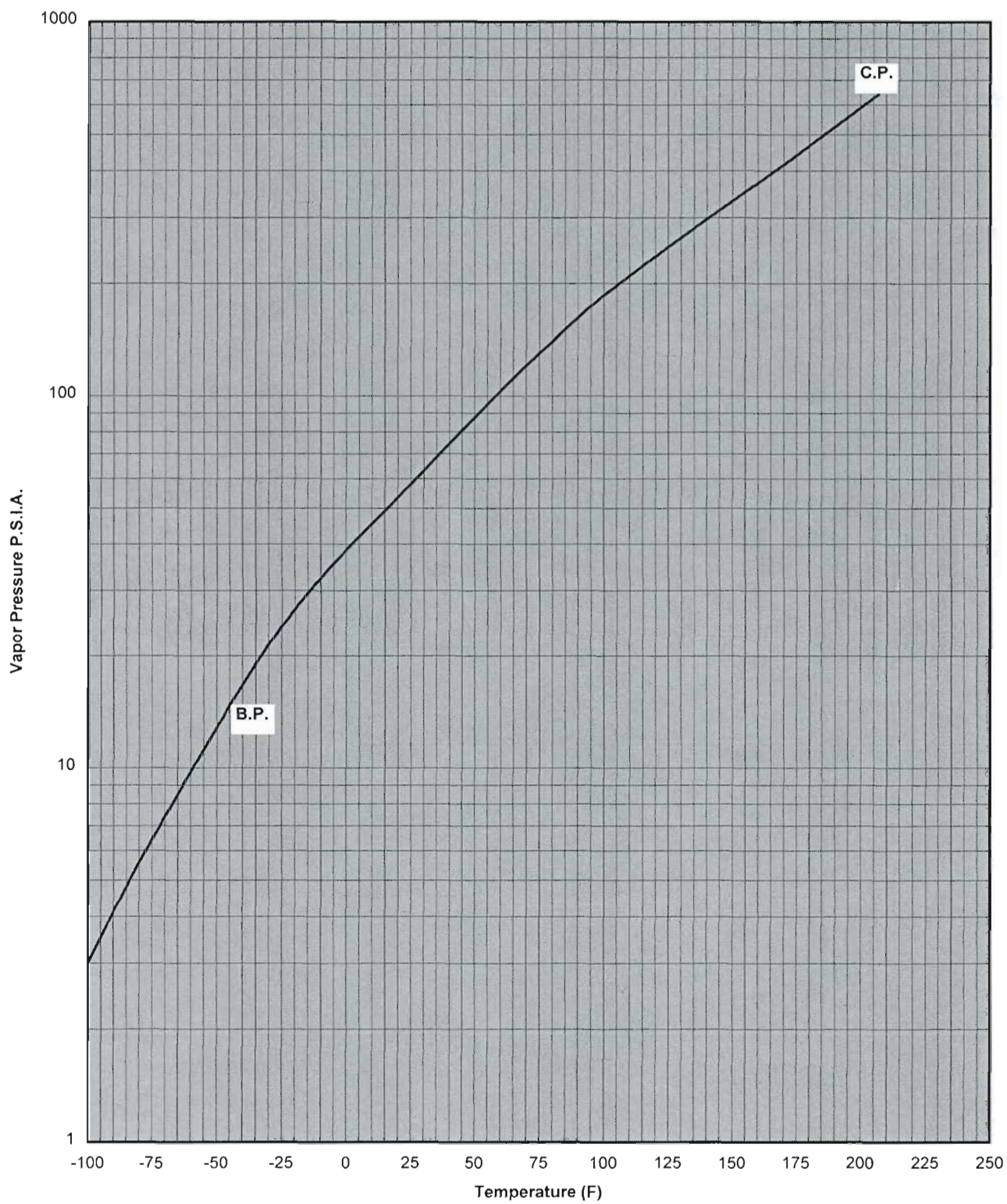

92

# Propylene

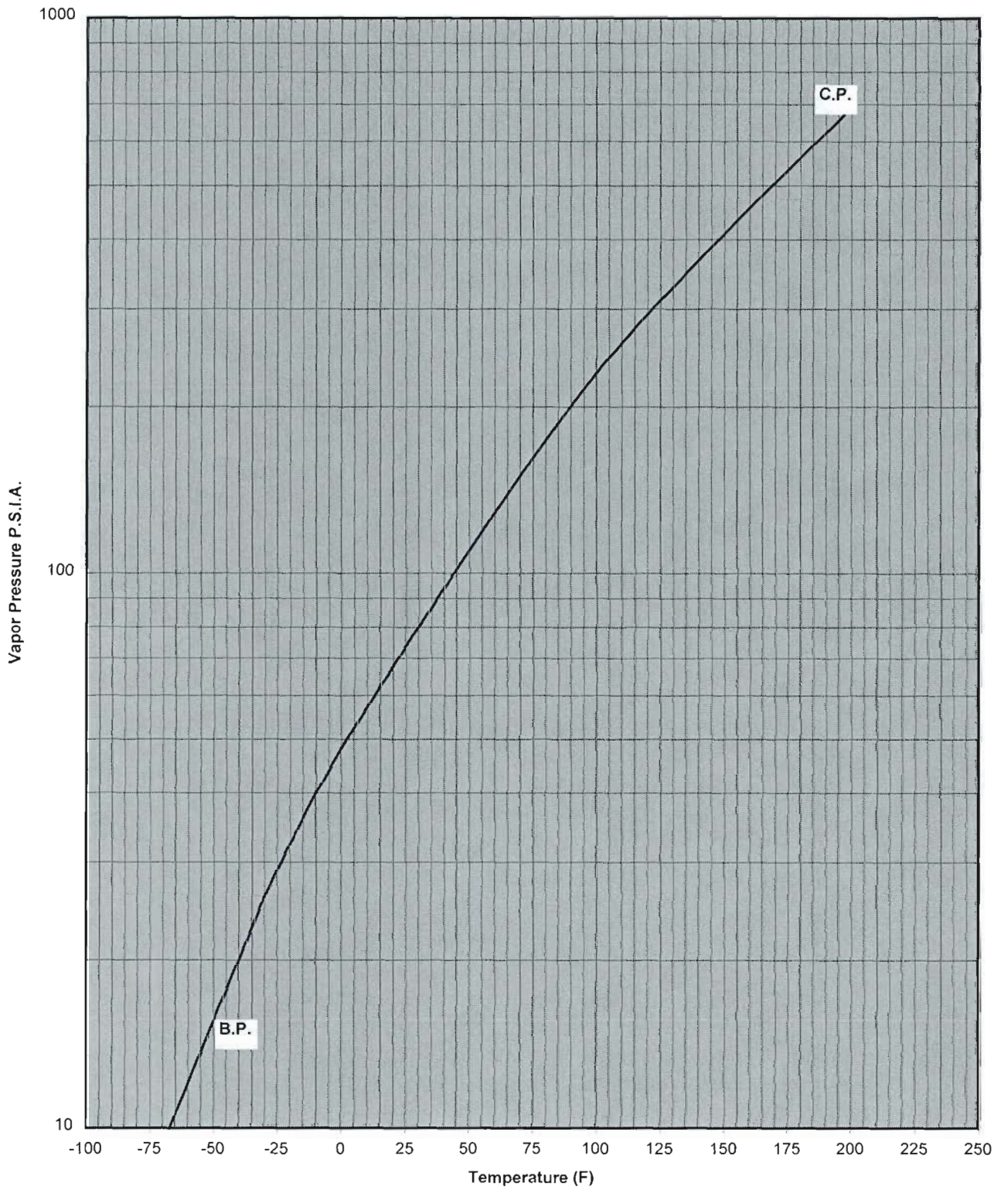

# Sulfur Dioxide

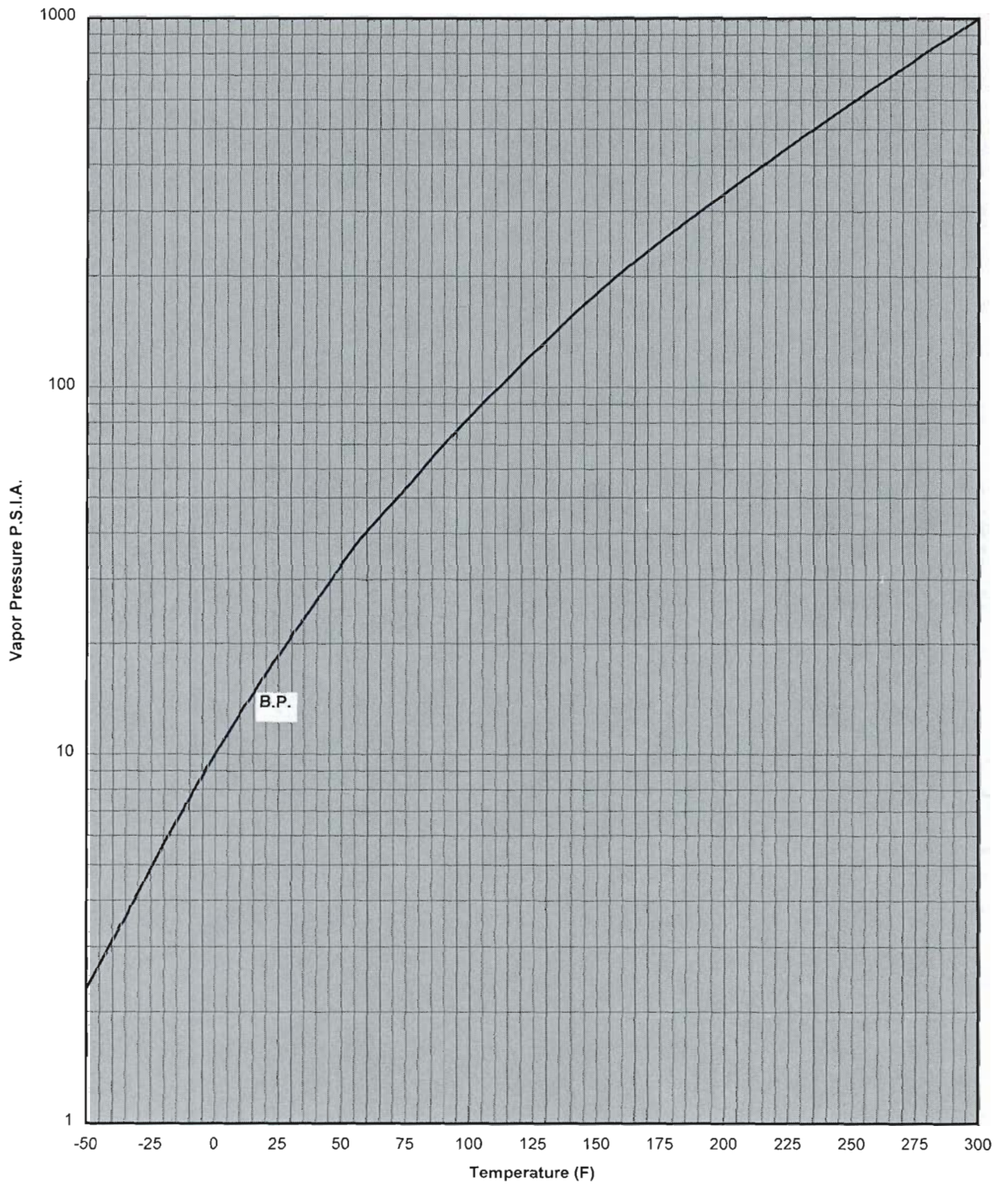

74

# Trimethylamine

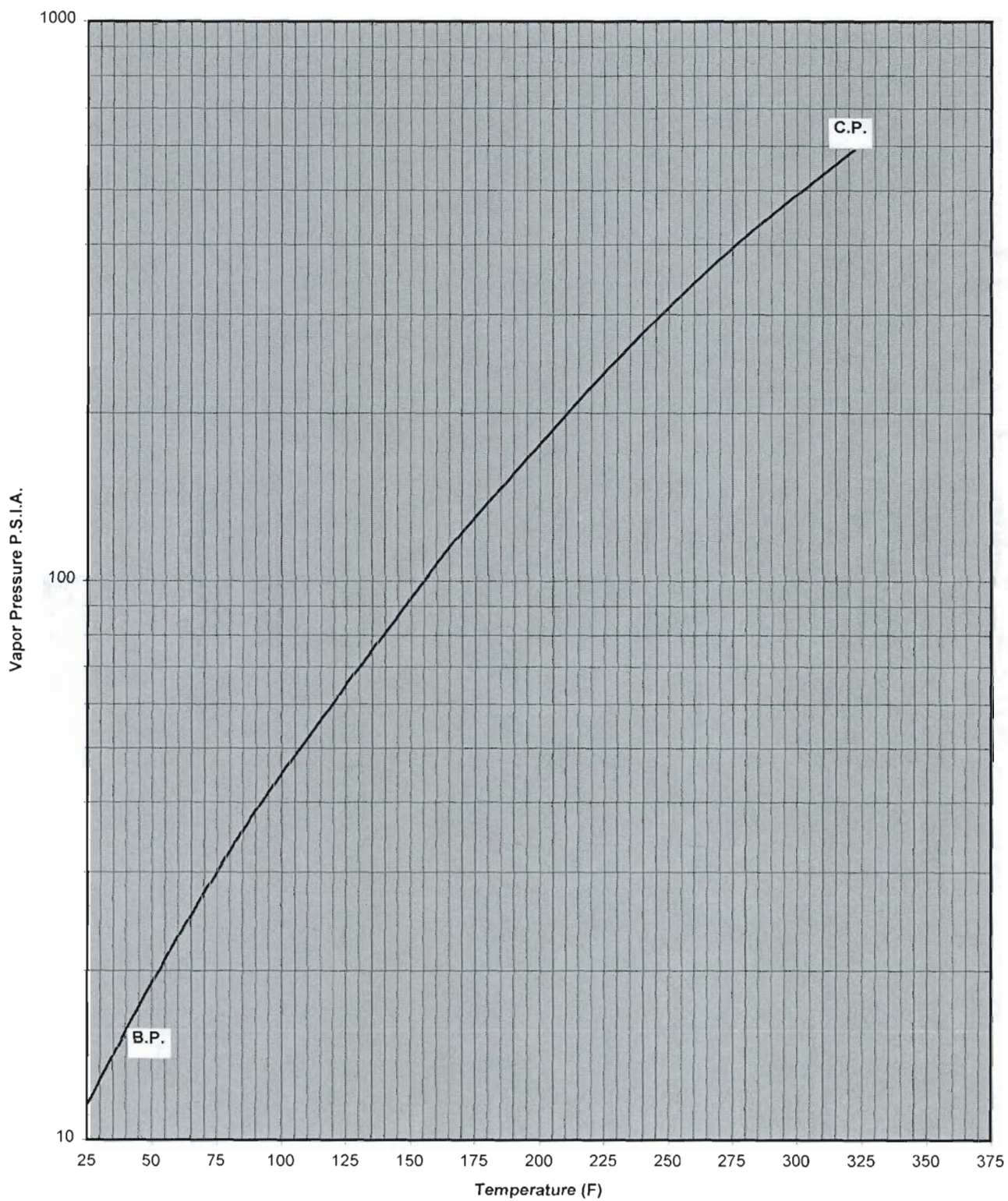

15

# Vinyl Chloride

