

**FLEXIBLE DELINEATOR
GROUND MOUNTED**

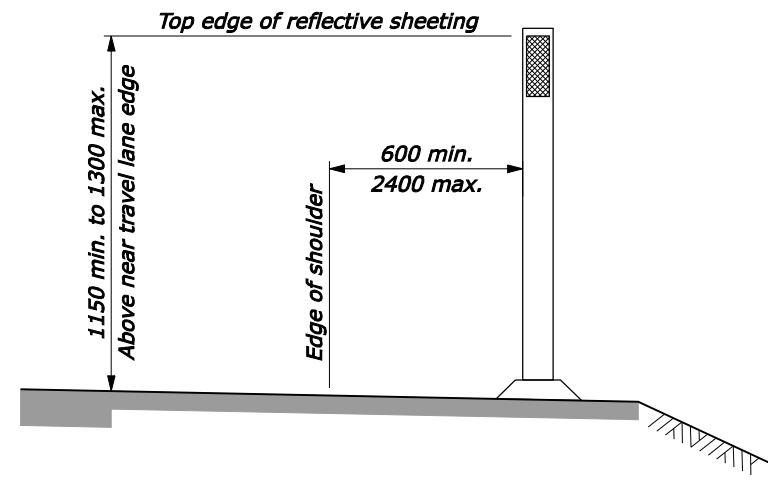

**FLEXIBLE DELINEATOR
SURFACE MOUNTED**

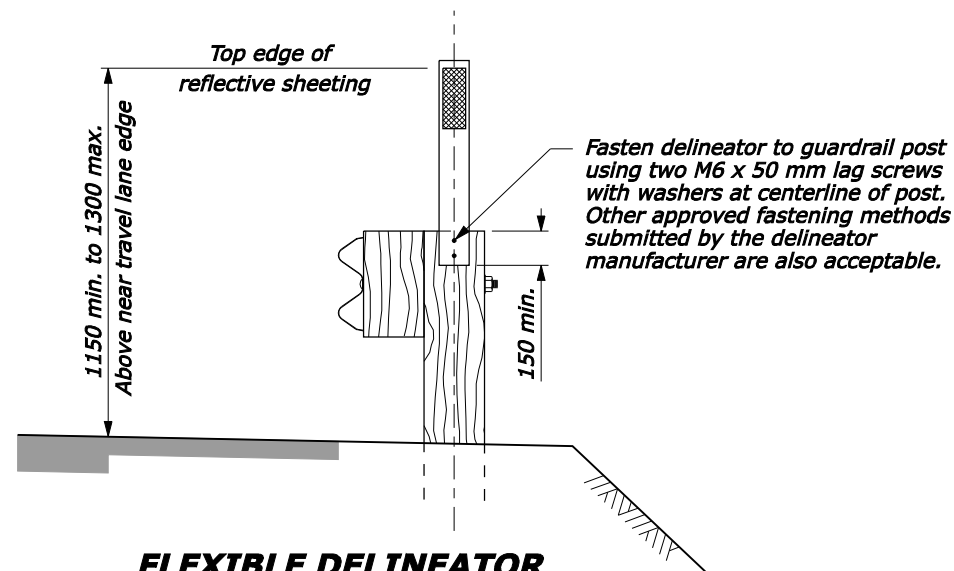

**FLEXIBLE DELINEATOR
GUARDRAIL MOUNTED OPTION
(Use only with wood guardrail posts)**

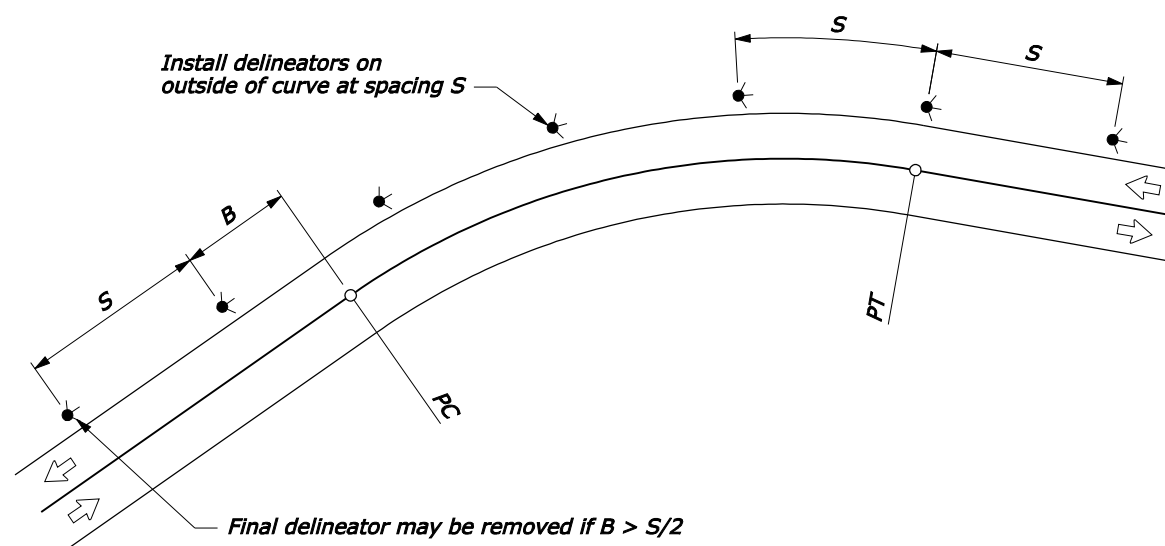

PLACEMENT ON HORIZONTAL CURVES

DELINEATOR SPACING ON HORIZONTAL CURVES	
CURVE RADIUS (m)	SPACING (S) (m)
15	6
35	8
55	11
75	13
95	15
125	18
155	20
185	22
215	24
245	26
275	27
305	29

Spacing for a specific curve may be interpolated from the table, or calculated using the formula:
 $Spacing = 1.7 \sqrt{R-15}$
 The minimum spacing should be 6 meters. Curve spacing should not exceed 90 meters.

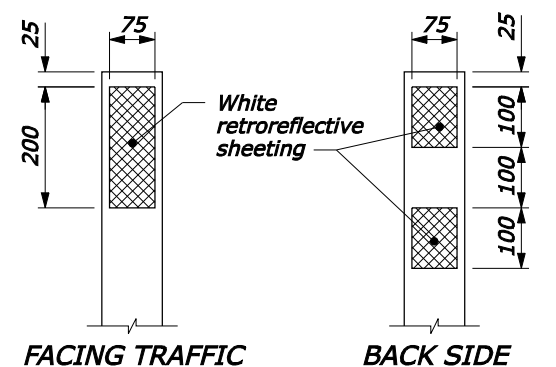

**FACING TRAFFIC
BACK SIDE
REFLECTIVE SHEETING DETAIL**

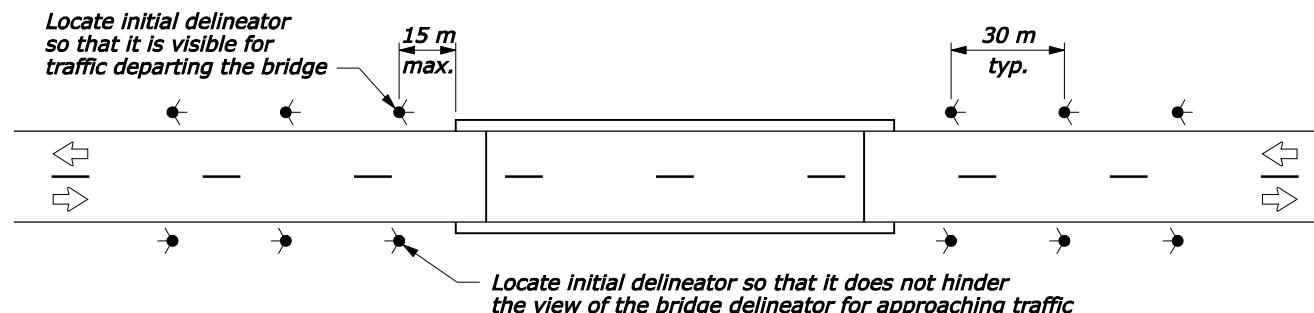

PLACEMENT AT BRIDGE APPROACHES

- NOTE:**
1. When a delineator falls within a cross road or approach, the delineator may be moved in either direction a distance not to exceed one quarter of the normal spacing. Eliminate the delineator if this allowance is exceeded.
 2. Place delineators 600 mm from the edge of design shoulder unless otherwise specified.
 3. Install delineators behind the rail at guardrail locations. Either drive the delineator in line with the guardrail posts or mount a shorter delineator onto the guardrail post as shown on this sheet.
 4. When the contract does not provide for the construction of the ultimate pavement, allow for the thickness of base and pavement to be placed later when establishing the elevation of the traffic delineators.
 5. Use the current edition of the Manual on Uniform Traffic Control Devices for Streets and Highways (MUTCD) as a guide for delineation layout.
 6. Furnish hardware in the metric sizes shown. Equivalent US Customary sizes may be used when metric sizes are not available.
 7. Dimensions without units are millimeters.

NO SCALE

U.S. DEPARTMENT OF TRANSPORTATION FEDERAL HIGHWAY ADMINISTRATION WESTERN FEDERAL LANDS HIGHWAY DIVISION	
METRIC DETAIL	
WASHINGTON DELINEATORS	
DETAIL APPROVED FOR USE 1/2008	DETAIL
REVISED:	WM633-80