

POST DETAIL

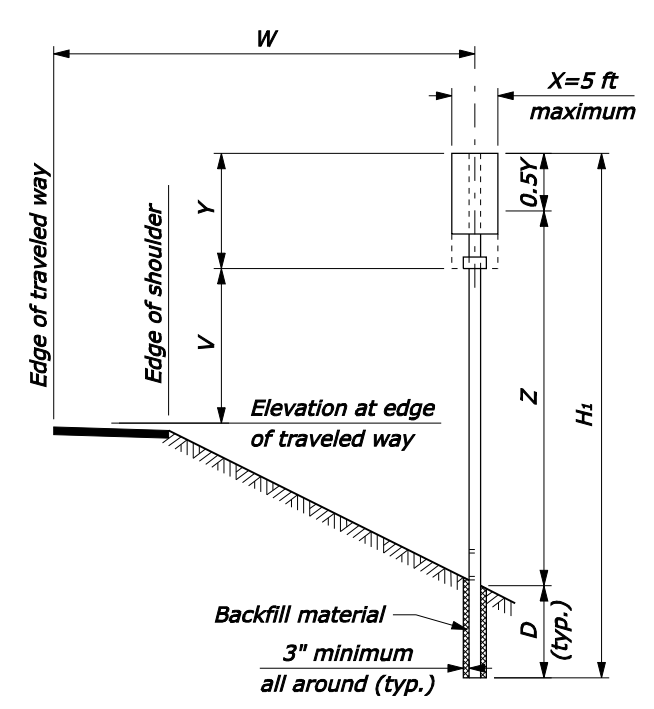

SINGLE POST SIGNS

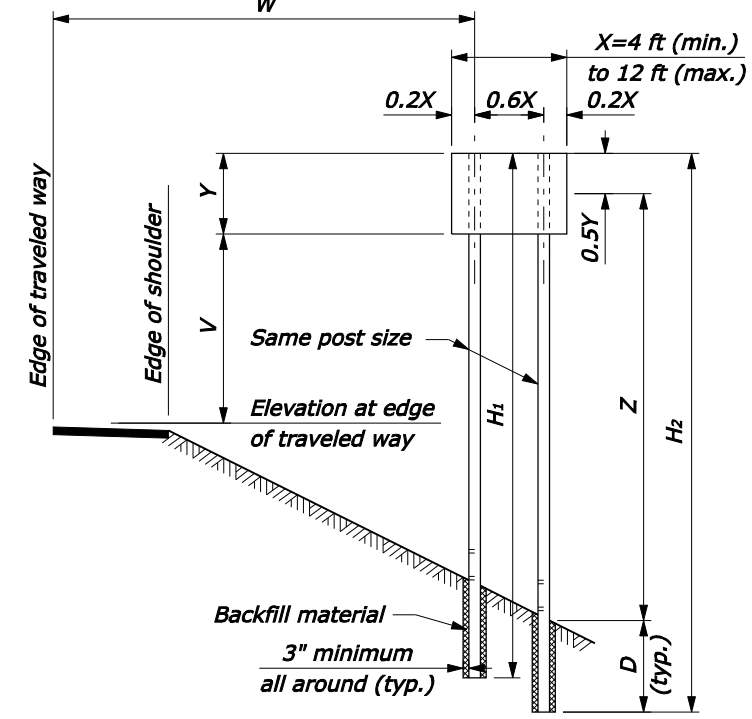

TWO POST SIGNS

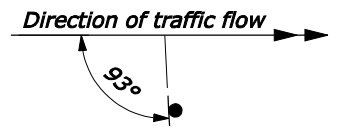

SIGN INSTALLATION ANGLE
For all retroreflectorized signs where W > 25'

MINIMUM DISTANCE TO SIGN		
Location	Lateral Offset (W)	Mounting Height (V)
Rural Districts	6 ft	5 ft
Business or Residence Districts	2 ft from curb	7 ft

V may be reduced by 1 foot in rural districts for a secondary sign mounted below another sign.

- NOTE:**
- Traffic barrier protection is required for all posts larger than 6" x 8" when located within the clear zone or if the post is vulnerable to being struck when placed outside the clear zone.
 - H₁ thru H₄ indicate overall post length. Select post lengths to fit field conditions.
 - D is the minimum post embedment depth for average soil conditions. See Wood Post Selection Table below.
 - Z is the height from ground line to mid-height of sign at the longest post.
 - For the purpose of post selection X and Y are as follows:
 - Single sign, or back to back signs: X and Y are the overall dimensions of the signs.
 - Multiple sign installations: X and Y are the dimensions of a rectangle enclosing all the signs.

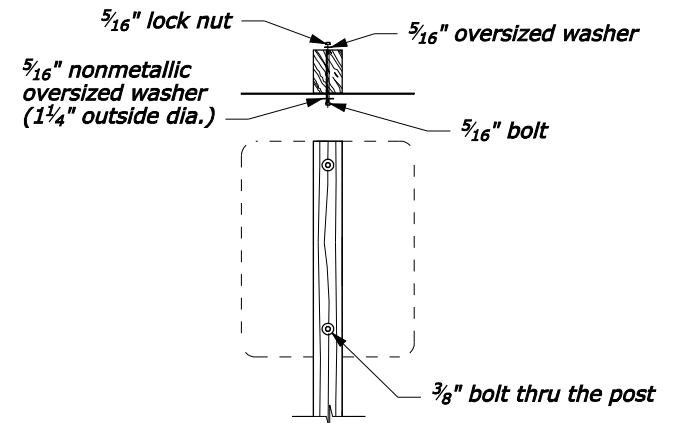

TYPICAL MOUNTING FOR SIGNS WITHOUT ANGLES

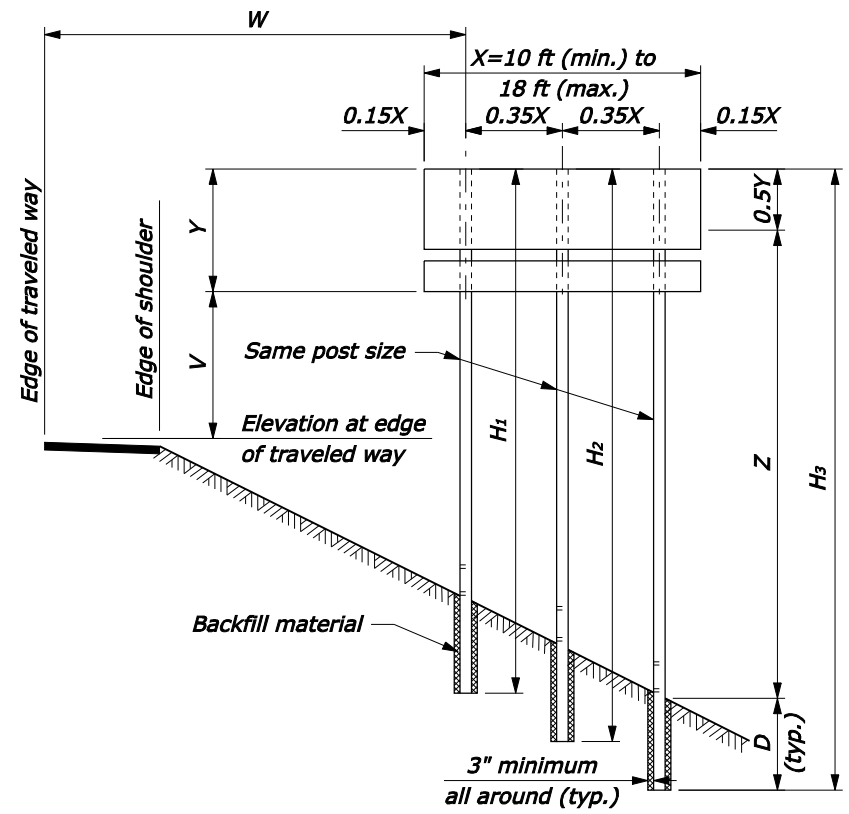

THREE POST SIGNS

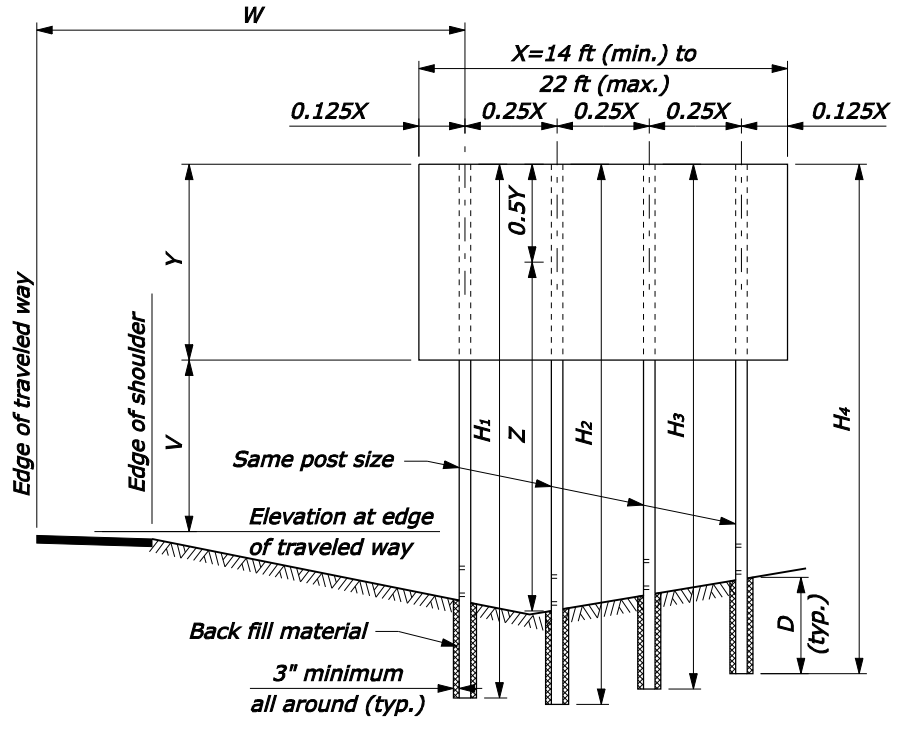

FOUR POST SIGNS

POST SIZE (inch)	NUMBER OF POSTS				D	Notch depth and hole diameter
	1	2	3	4		
	Product of X-Y-Z in CUFT					
4 x 4	80	155	235	310	3'-0"	-
4 x 6	180	385	545	725	4'-0"	1 3/4"
6 x 6	235	475	710	950	4'-0"	1 3/4"
6 x 8	300	850	1280	1700	4'-0"	2 1/2"
6 x 10	385	1180	1170	2360	5'-0"	-
8 x 10	575	1610	2410	3215	5'-0"	-
8 x 12	775	2310	3465	4620	6'-0"	-

Values shown are the maximum permitted. If the product of XYZ exceeds the limit for the largest post, use steel post installation.

NO SCALE

U.S. DEPARTMENT OF TRANSPORTATION
FEDERAL HIGHWAY ADMINISTRATION
WESTERN FEDERAL LANDS HIGHWAY DIVISION

U.S. CUSTOMARY DETAIL
**PERMANENT SIGN INSTALLATION
WOOD POSTS**

DETAIL APPROVED FOR USE -/---

REVISID: 2/1998
DRAFT: 1/2007

DETAIL
W633-7