

CHAIN LINK FENCE

- NOTE:**
- Dimensions not labeled are in millimeters.
 - Metal post and rails shall conform to ASTM F 761.
 - Set all posts in concrete. Set corner, end, pull posts to the dimensions shown. The minimum depth of concrete for line posts is 600 mm. Increase depth 75 mm for each additional 300 mm of fence height over 1200 mm.
 - Adjust the post top elevations to provide a smooth visual fence profile. Install corner posts at horizontal breaks in the fence of 15° or more.
 - Provide fence fabric with a 50 mm mesh. Use 3.05 mm wire in fabric heights of 1200 mm or less and 3.76 mm wire in fabric heights greater than 1200 mm. Provide a Class D coating when zinc-coated steel fence fabric is provided. Knuckle both selvages on fabric.
 - See Detail WM619-21 for hardware and gate requirements.

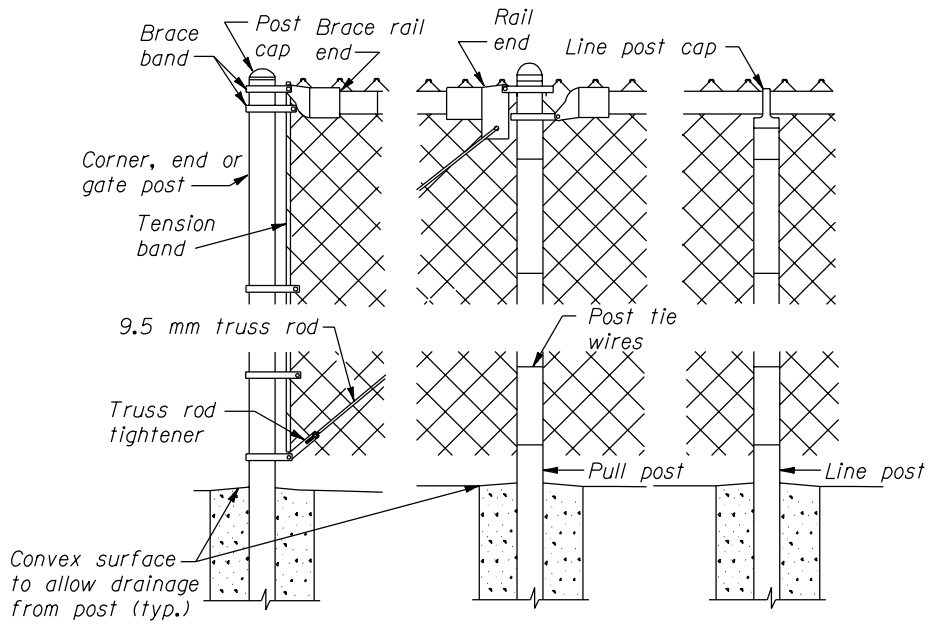

CHAIN LINK DETAIL

CHAIN LINK FENCE POST SIZE AND WEIGHT TABLE			
DESCRIPTION	FENCE HEIGHT	ROUND PIPE	
		Yield strength 172 Mpa (min.)	
		dia. mm	kg/m (min.)
Brace rail & top rail	1500 mm or less	33.40	1.10
	1800 mm	33.40	1.10
Line post	1500 mm or less	42.16	1.65
	1800 mm	48.26	1.89
End, corner & pull post	1500 mm or less	35.56	1.89
	1800 mm	60.32	2.38

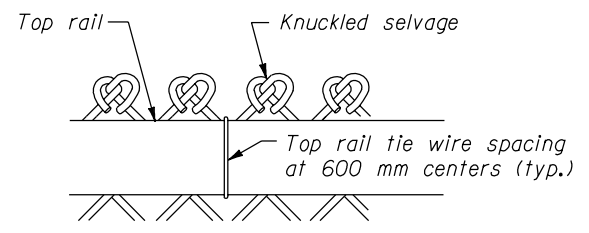

WIRE SELVAGE DETAIL

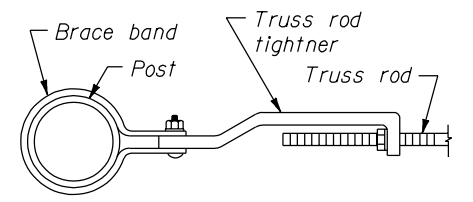

TRUSS ROD TIGHTENER DETAIL

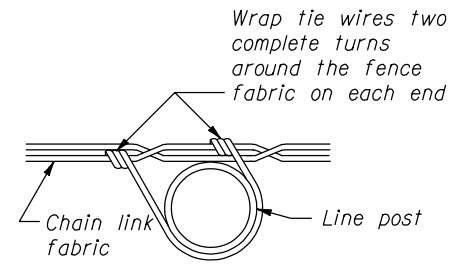

CHAIN LINK FENCE TIE DETAIL

NO SCALE

U.S. DEPARTMENT OF TRANSPORTATION
 FEDERAL HIGHWAY ADMINISTRATION
 WESTERN FEDERAL LANDS HIGHWAY DIVISION

METRIC DETAIL

RESIDENTIAL CHAIN LINK FENCE

DETAIL APPROVED FOR USE 3/1996

REVISID: _____

DETAIL WM619-20

13 DEC 2000 f:\standrow\metric\details\wm61920.dgn

HARDWARE ITEM DESCRIPTION	STANDARD REQUIREMENTS
Brace rail and top rail	See table on Detail WM619-20
Line post	See table on Detail WM619-20
Corner, end and pull posts	See table on Detail WM619-20
Post cap	Cast non-ferrous alloy or galvanized pressed steel cap must fit snugly on post and gate top
Line post cap	Galvanized pressed steel minimum 2.38 mm thickness or galvanized malleable ferrous alloy
Tension band	Minimum 2.38 x 75 mm galvanized steel
Brace band	Minimum 2.38 x 75 mm galvanized steel
Band bolt	Minimum M8 x 32 mm galvanized carriage bolt, (Lock washer & flat washer for each band)
Rail end	Galvanized pressed steel or galvanized malleable ferrous alloy minimum 9.53 mm thickness on back bolting appendage
Brace rail end	Galvanized pressed steel or galvanized malleable ferrous alloy minimum 9.53 mm thickness on back bolting appendage
Truss rod tightener	Minimum 6.4 mm formed galvanized steel
Truss rod	9.5 mm galvanized, NC threaded rod, lock washer, & flat washer with two 90° bends opposite of threaded end
Top rail sleeve	Galvanized steel 1.30 mm minimum thickness by 150 mm minimum length
Tension bar	Minimum 4.76 x 75 mm galvanized steel
Fence fabric	50 mm diamond mesh fabric, See note no. 5 on Detail WM619-20
Tie wires	Minimum 3.76 mm aluminum with one hooked end
Gate latch	Minimum 3.18 mm galvanized pressed steel or malleable ferrous alloy. 1 latch per each single gate with bent minimum M10 attachment bolt, washer & nut.
Frame hinge	Minimum 3.18 mm galvanized pressed steel with 2 - M10 U-bolts, lockwasher & nuts per hinge. Use 2 hinges per gate leaf up to 2400 mm in width and 3 hinges per gate leaf widths greater than 2400 mm.
Drop rod latch & guide	Minimum 3.18 mm galvanized pressed steel. Drop rod guide includes M10 x 75 mm carriage bolt with lock washer & nut. Weld drop rod fork to rod & paint with an approved zinc rich paint.

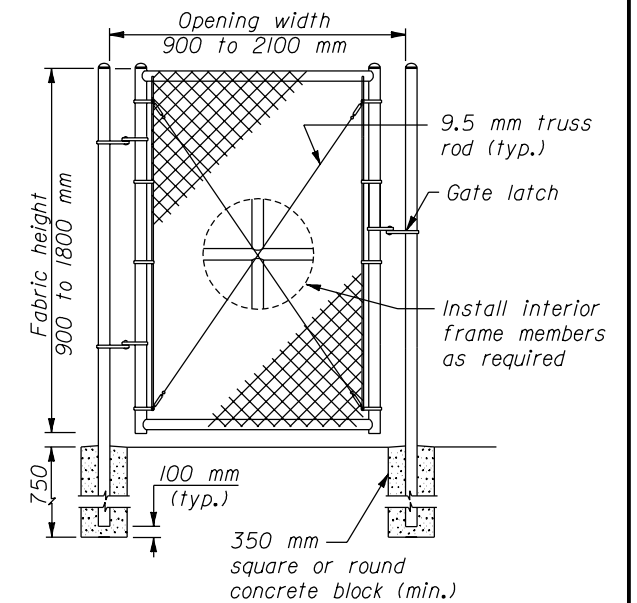
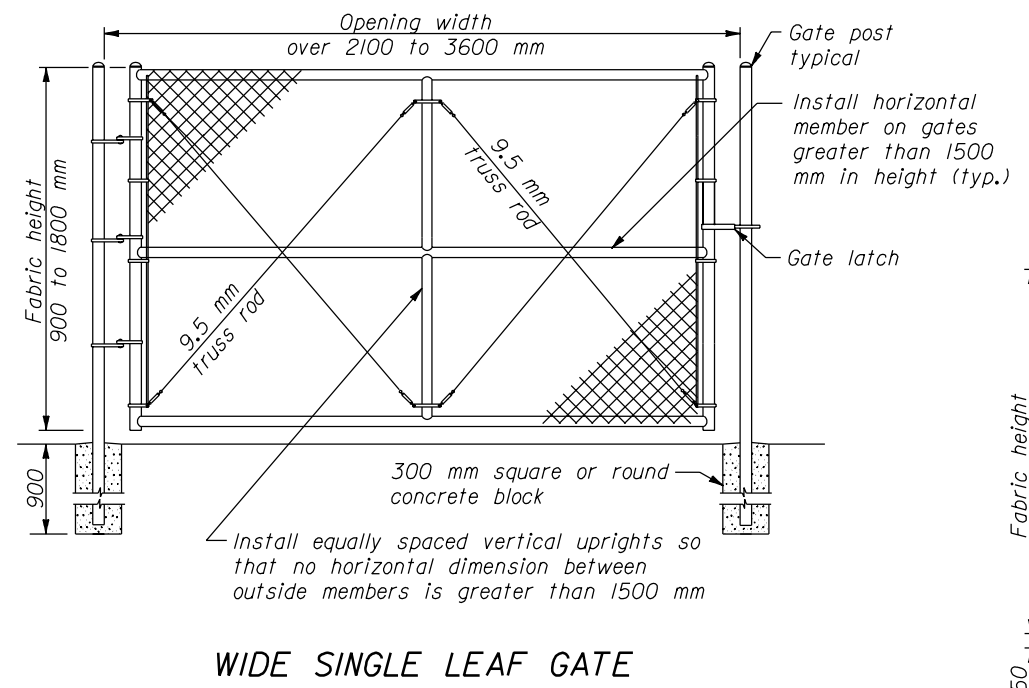
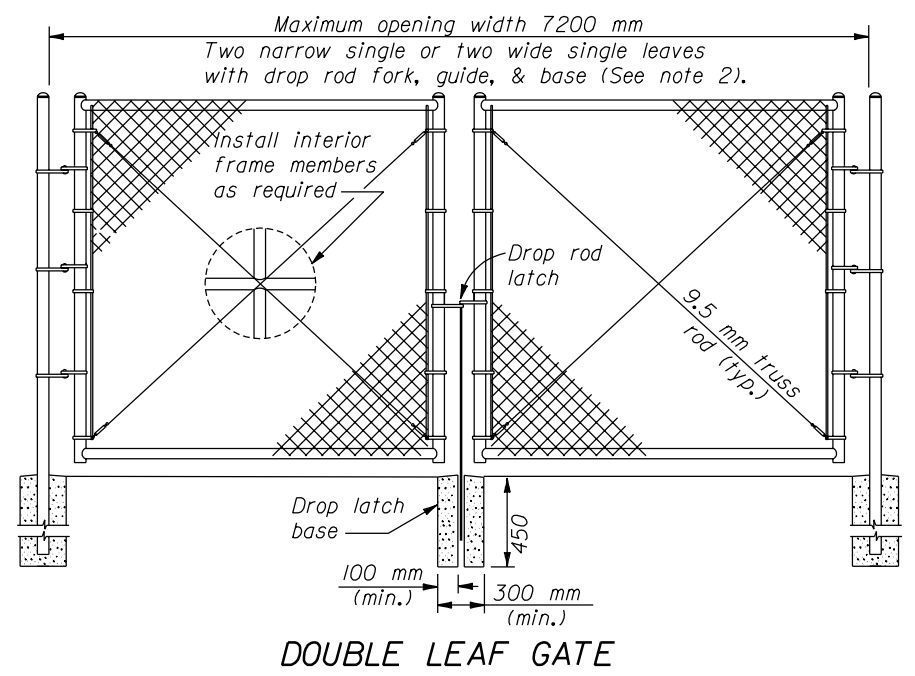

- NOTE:**
- Dimensions not labeled are in millimeters.
 - Reinforce the gate frame corners with a malleable iron or pressed steel fitting designed for the purpose or shop weld the corners. Grind smooth all welds and paint with an approved zinc rich paint. Furnish each gate with the necessary hinges, latch, and drop rod locking device designed for the type of gate posts and gate used on the project. Provide positive type latching devices with provisions for pad locking at all gates. Provide keepers to retain the gate in the open position.
 - Approved alternate gate frames constructed of steel sections, other than pipe, may be used.
 - The design of the chain link hardware may vary from the details shown, however, all hardware and materials used in a single installations shall be uniform and compatible.
 - Furnish hardware in the metric sizes shown. Equivalent imperial sizes may be used when metric sizes are not available.

GATE LEAF WIDTHS		CHAIN LINK GATE POST AND FRAME SIZE AND MASS TABLE							
		Minimum yield strength 172 Mpa.							
		ROUND TUBING				SQUARE TUBING			
		Steel		Aluminum		Steel		Aluminum	
		dia. mm	kg/m (min.)	dia. mm	kg/m (min.)	dia. mm	kg/m (min.)	dia. mm	kg/m (min.)
1200 mm or less	Gate	4.83	1.87	4.83	1.29	50x50	3.50	50x50	1.40
Over 1200 to 2100 mm	post	6.03	3.18	6.03	1.88	64x64	4.06	64x64	1.88
Over 2100 mm	size	6.03	4.64	6.03	2.98	64x64	5.78	64x64	4.32
Outside frame member	frame	3.34	1.29	3.34	0.65	32x32	1.56	32x32	0.86
Interior bracing member	size	3.34	1.29	3.34	0.65	32x32	1.56	32x32	0.86

NO SCALE

U.S. DEPARTMENT OF TRANSPORTATION
FEDERAL HIGHWAY ADMINISTRATION
WESTERN FEDERAL LANDS HIGHWAY DIVISION

METRIC DETAIL

RESIDENTIAL CHAIN LINK HARDWARE AND GATE

DETAIL APPROVED FOR USE 3/1996

REVISID:

DETAIL WM619-21

f:\standrow\metric\details\wm61921.dgn 13 DEC 2000

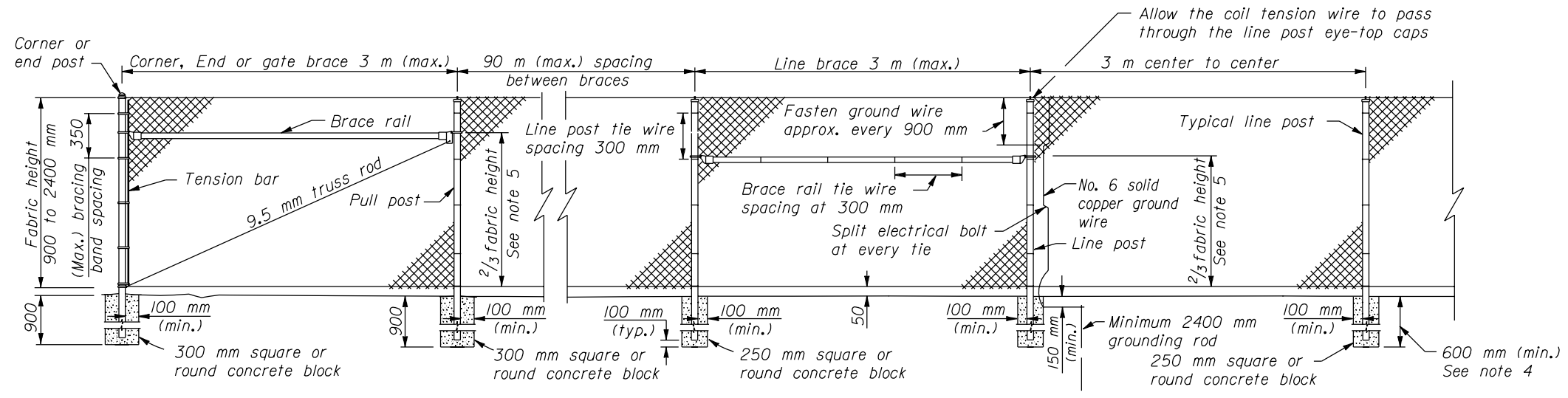

CHAIN LINK FENCE

- NOTE:**
- Dimensions not labeled are in millimeters.
 - Metal post and rails shall conform to ASTM F 669.
 - Use Type I requirements from the chain link fence table unless otherwise specified in the special contract requirements.
 - Set all posts in concrete. Set corner, end, pull posts to the dimensions shown. The minimum depth of concrete for line posts is 600 mm. Increase depth 75 mm for each additional 300 mm of fence height over 1200 mm.
 - Install braces on all terminals on fences without a top rail. No braces are required on fabric 1800 mm in height or less where a top rail is specified. Install braces where fabric is over 1800 mm in height. Where a top rail is used, attach the brace at the halfway point of the terminal post above grade and, where the rail is omitted, at the two-thirds point above grade. Do not install top rail unless so specified in the special contract requirements.
 - Adjust the post top elevations to provide a smooth visual fence profile. Install corner posts at horizontal breaks in the fence of 15° or more.
 - If alternate steel posts are used, provide fastening bands, caps, brace rail, rail ends, and truss rod attaching hardware compatible with the post sizes and styles selected.
 - Provide fence fabric with a 50 mm mesh. Use 3.05 mm wire in fabric heights of 1200 mm or less and 3.76 mm wire in fabric heights greater than 1200 mm. Provide a Class D coating when zinc-coated steel fence fabric is provided. Knuckle both selvages on fabric less than 1800 mm high. For fabric 1800 mm high or higher, knuckle one selvage and twist the other.
 - See Detail WM619-23 for hardware and gate requirements.

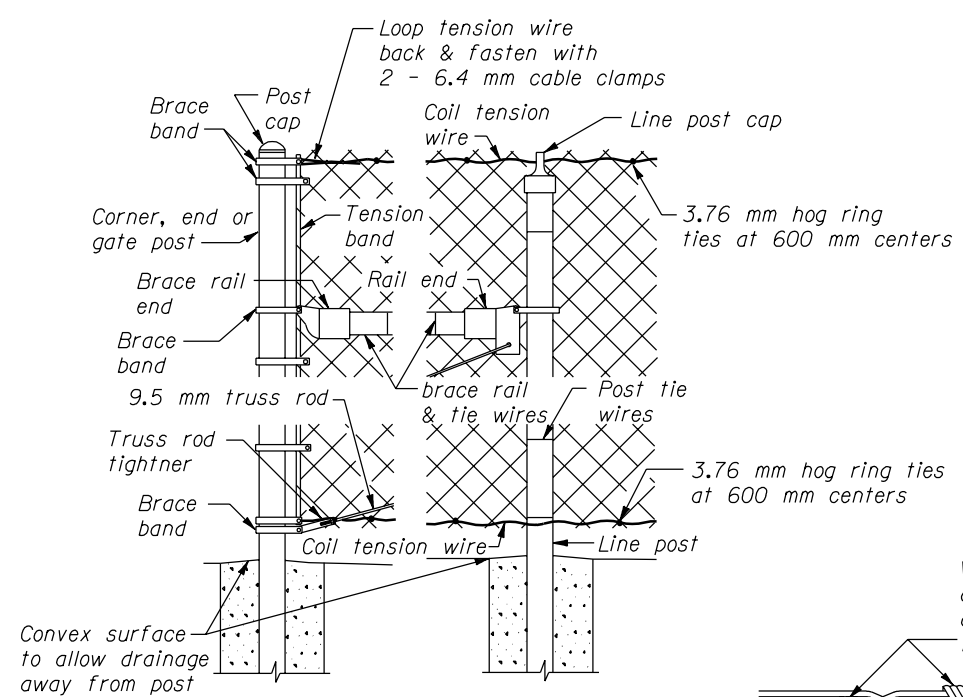

CHAIN LINK DETAIL

CHAIN LINK FENCE													
POST SIZE AND WEIGHT TABLE													
DESCRIPTION	FENCE TYPE	ROUND PIPE		HOT ROLLED H-SHAPE		ROLLED FORMED							
		Steel	Aluminum	Steel	Steel	Steel							
		Minimum yield strength Mpa.											
		172	172	345	310	310							
Size and mass													
		dia. mm	mass kg/m	dia. mm	mass kg/m	dia. mm	mass kg/m	dia. mm	mass kg/m	dia. mm	mass kg/m		
Brace rail & top rail	Type 1	4.22	3.38	4.22	1.17	4.22	2.08	---	---	32x40	2.08		
	Type 2	4.22	2.71	---	---	4.22	2.08	---	---	32x40	2.08		
Line post	Type 1	6.03	5.45	6.03	1.88	6.03	4.64	55x43.25	4.85	57x40	4.02		
	Type 2	6.03	4.40	---	---	6.03	3.44	---	---	28x40	3.36		
End, corner & pull post	Type 1	7.30	8.62	7.30	2.98	7.30	6.91	---	---	90x90	7.60		
	Type 2	7.30	6.98	---	---	7.30	4.84	---	---	90x90	7.60		

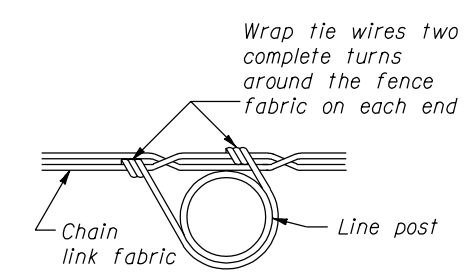

CHAIN LINK FENCE TIE DETAIL

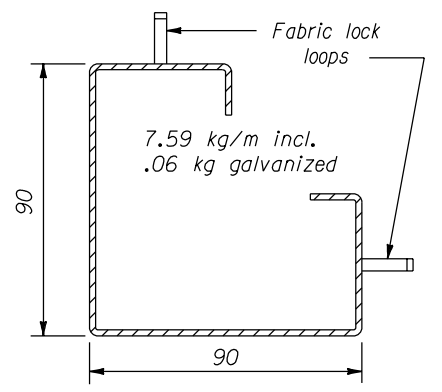

END OR CORNER POST

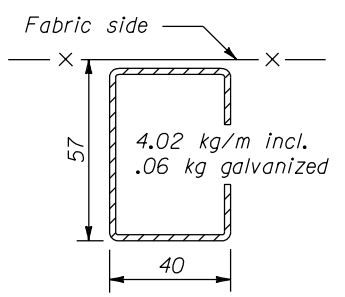
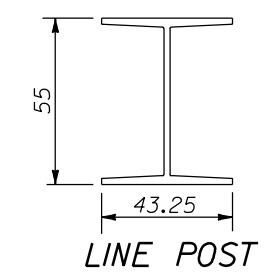

LINE POST

TOP & BRACE RAIL

ALTERNATE STEEL POST & BRACE SECTIONS

NO SCALE

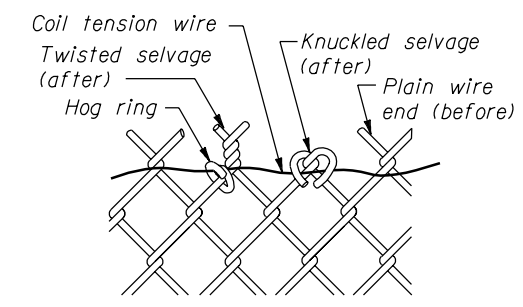

WIRE SELVAGE DETAIL

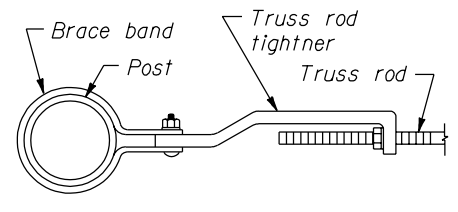

TRUSS ROD TIGHTNER DETAIL

13 DEC 2000 f:\standrow\metric\details\wm61922.dgn

U.S. DEPARTMENT OF TRANSPORTATION
FEDERAL HIGHWAY ADMINISTRATION
WESTERN FEDERAL LANDS HIGHWAY DIVISION

METRIC DETAIL

CHAIN LINK FENCE

DETAIL APPROVED FOR USE 3/1996
REVISID: _____

DETAIL
WM619-22

HARDWARE ITEM DESCRIPTION	STANDARD REQUIREMENTS
Brace rail and top rail 	See table on Detail WM619-22
Line post 	See table on Detail WM619-22
Corner, end and pull posts 	See table on Detail WM619-22
Post cap 	Cast non-ferrous alloy or galvanized pressed steel cap must fit snugly on post and gate top
Line post cap 	Galvanized pressed steel minimum 2.38 mm thickness or galvanized malleable ferrous alloy
Tension band 	Minimum 3.18 x 75 mm galvanized steel
Brace band 	Minimum 3.18 x 75 mm galvanized steel
Band bolt 	Minimum M10 x 45 mm galvanized carriage bolt, (Lock washer & flat washer for each band)
Rail end 	Galvanized pressed steel or galvanized malleable ferrous alloy minimum 9.53 mm thickness on back bolting appendage
Brace rail end 	Galvanized pressed steel or galvanized malleable ferrous alloy minimum 9.53 mm thickness on back bolting appendage
Truss rod tightner 	Minimum 9.52 mm formed galvanized steel
Truss rod 	9.5 mm galvanized, nc threaded rod, lock washer, & flat washer with two 90° bends opposite of threaded end
Top rail sleeve 	Galvanized steel 1.30 mm minimum thickness by 150 mm minimum length
Tension bar 	Minimum 4.76 x 75 mm galvanized steel
Fence fabric 	50 mm diamond mesh fabric, See note no. 8 on Detail WM619-22
Tie wires 	Minimum 3.76 mm aluminum with one hooked end
Coil tension wire 	4.50 minimum diameter metallic coated wire
Gate latch 	Minimum 3.18 mm galvanized pressed steel or malleable ferrous alloy. 1 latch per each single gate with bent minimum M10 attachment bolt, washer & nut.
Frame hinge 	Minimum 3.18 mm galvanized pressed steel with 2 - M10 U-bolts, lockwasher & nuts per hinge. Use 2 hinges per gate leaf up to 2400 mm in width and 3 hinges per gate leaf widths greater than 2400 mm.
Drop rod latch & guide 	Minimum 3.18 mm galvanized pressed steel. Drop rod guide includes M10 x 75 mm carriage bolt with lock washer & nut. Weld drop rod fork to rod & paint with an approved zinc rich paint.

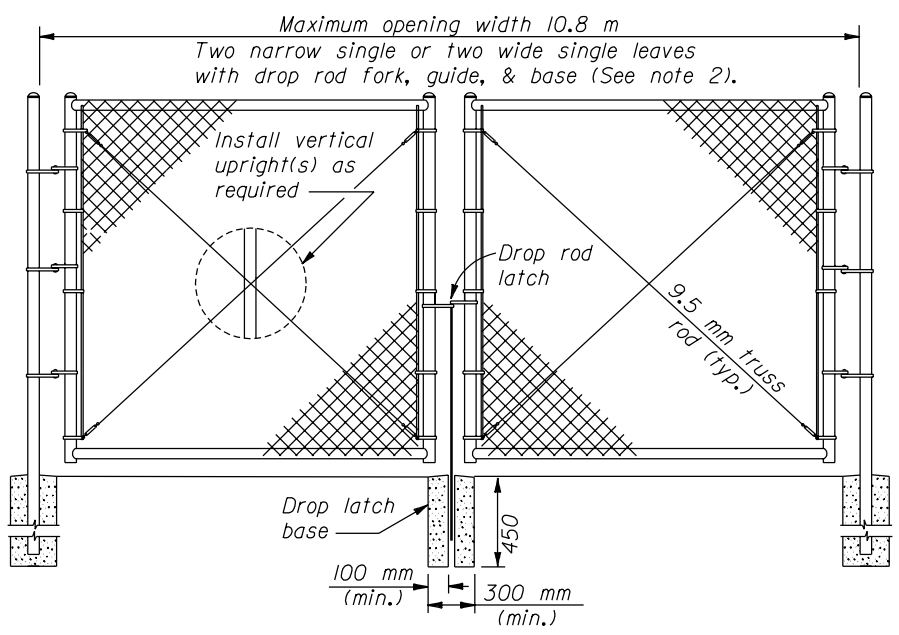

DOUBLE LEAF GATE

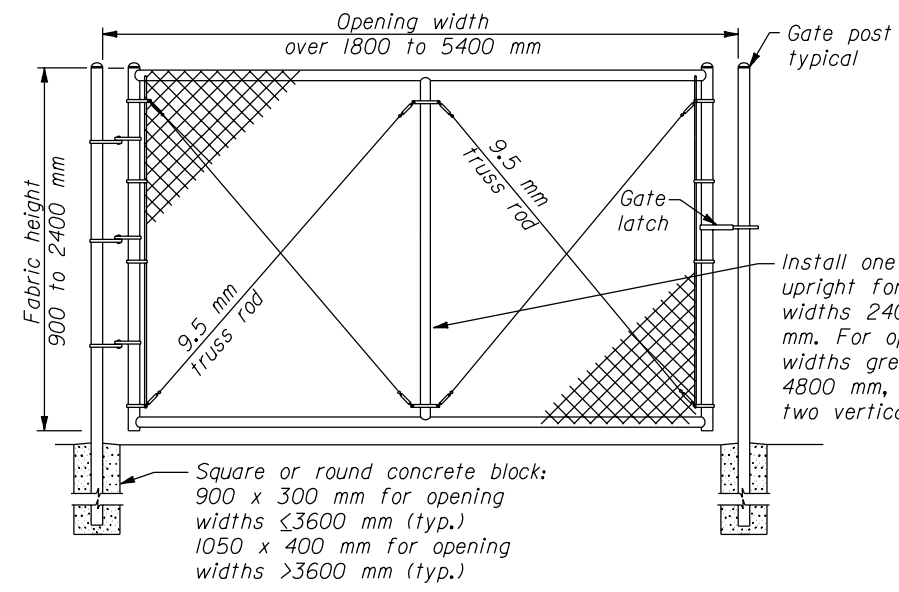

WIDE SINGLE LEAF GATE

GATE LEAF WIDTHS		CHAIN LINK GATE POST AND FRAME SIZE AND WEIGHT TABLE					
		ROUND PIPE					
		Steel		Aluminum		Steel	
		Minimum yield strength Mpa.					
		172		172		345	
		Size and mass					
		dia. mm	kg/m	dia. mm	kg/m	dia. mm	kg/m
		(min.)		(min.)		(min.)	
1800 mm or less	Gate	7.30	6.91	7.30	2.89	7.30	6.91
Over 1800 to 3600 mm	post	10.16	12.87	10.16	4.45	10.16	9.76
Over 3600 to 5400 mm	size	16.83	26.82	---	---	---	---
Outside frame member	frame	4.83	3.39	4.83	1.35	4.83	3.39
Interior bracing member	size	4.22	2.72	4.83	1.35	4.22	2.74

- NOTE:**
- All dimensions on this drawing are in millimeters.
 - Reinforce the gate frame corners with a malleable iron or pressed steel fitting designed for the purpose or shop weld the corners. Grind smooth all welds and paint with an approved zinc rich paint. Furnish each gate with the necessary hinges, latch, and drop rod locking device designed for the type of gate posts and gate used on the project. Provide positive type latching devices with provisions for pad locking at all gates. Provide keepers to retain the gate in the open position.
 - Approved alternate gate frames constructed of steel sections, other than pipe, may be used.
 - The design of the chain link hardware may vary from the details shown, however, all hardware and materials used in a single installations shall be uniform and compatible.
 - Furnish hardware in the metric sizes shown. Equivalent imperial sizes may be used when metric sizes are not available.

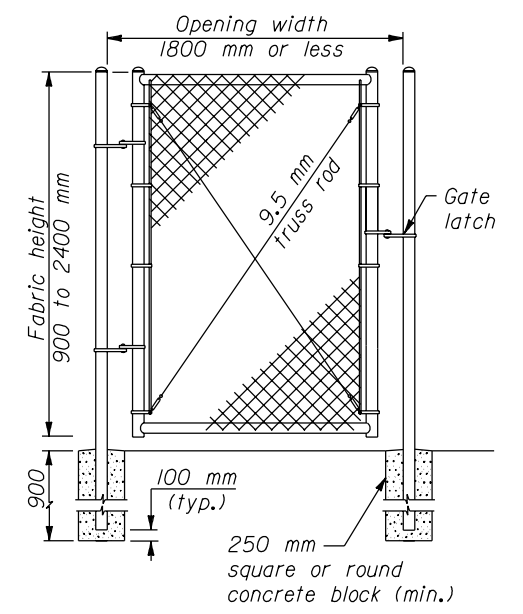

NARROW SINGLE LEAF GATE

U.S. DEPARTMENT OF TRANSPORTATION
FEDERAL HIGHWAY ADMINISTRATION
WESTERN FEDERAL LANDS HIGHWAY DIVISION

METRIC DETAIL

CHAIN LINK HARDWARE AND GATE

DETAIL APPROVED FOR USE 3/1996

REVISID: _____

DETAIL **WM619-23**

NO SCALE

f:\standrow\metric\details\wm61923.dgn 13 DEC 2000

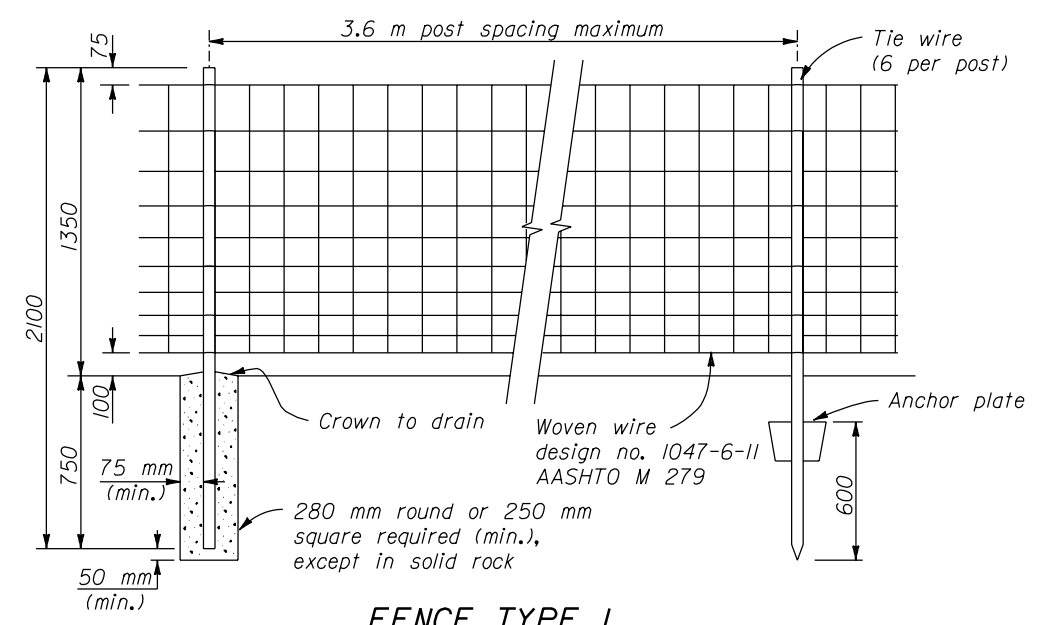

FENCE TYPE 1

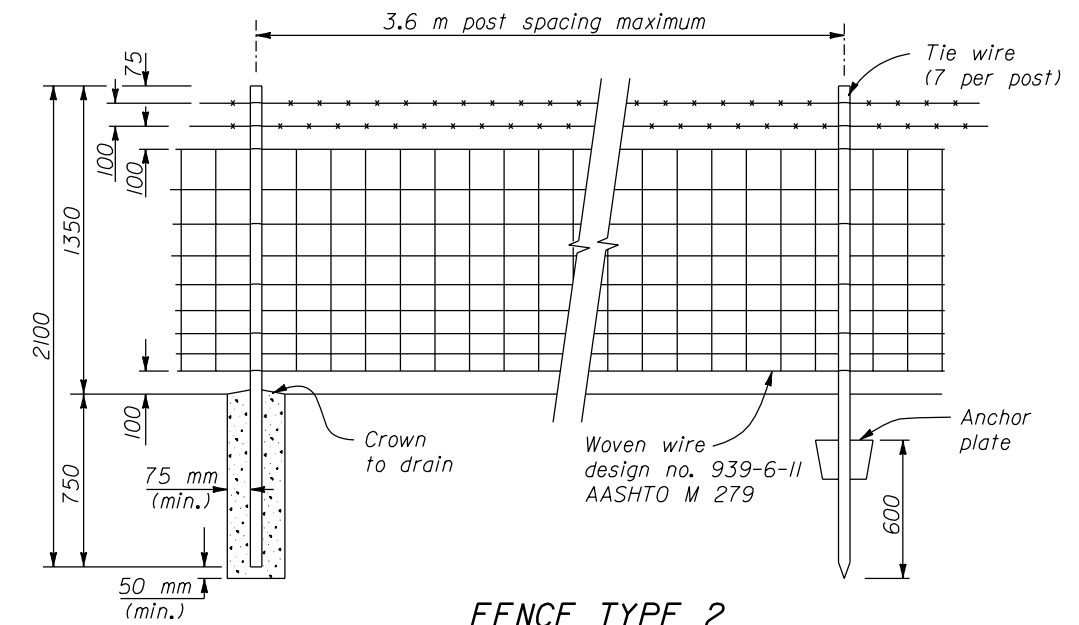

FENCE TYPE 2

NOTE:

- Dimensions not labeled are in millimeters.
- Furnish either zinc coated (galvanized) or aluminum coated steel barbed wire. Fabricate zinc coated barbed wire from two strands of 2.51 mm steel wire with a Class 3 zinc coated wire. Fabricate aluminum coated barbed wire from two strands of 2.51 mm aluminum coated steel wire with 4 point barbs of 2.03 mm aluminum coated or aluminum alloy wire.
- Furnish either zinc coated (galvanized) or aluminum coated steel wire fence fabric. If zinc coated fabric is furnished, use Grade 60 fabric with a Class 3 coating.
- Furnish 3.43 mm tie wire or wire clamps for fasteners in metal posts. Galvanize wire stays, tie wire, wire loops, and wire clamps with a Class 1 zinc coating according to ASTM A 641.
- Furnish either painted or galvanized steel fence posts for tee, channel or U bar shapes. Furnish galvanized steel round pipe or steel angle for posts and braces. Fit round pipe posts with snug-fitting galvanized metal caps. Fabricate steel line posts and angles from Type A steel according to AASHTO M 281. Fabricate steel pipe posts and braces according to AASHTO M 160.
- Place fencing on Right-of-Way line or where shown on plans.
- Manufacture gates of galvanized steel pipe not less than 25 mm nominal diameter, (nominal mass 2.50 kg per linear meter) for frame and vertical brace and wire mesh of the same design used in the fence. Equip each gate with one standard adjustable diagonal truss rod from corner to corner. Provide Hinges and 2-way self closing latch of an approved rust proof malleable iron or steel. Approved alternate gates may be used.
- Where a single opening requires two gates, provide an approved drop bar and fastener between the gates. Where two metal gates are installed in a single opening both gates will be measured for payment.
- Construct metal walk gates up to 1200 mm in width similar to Type 2 gate but omit vertical brace and truss.

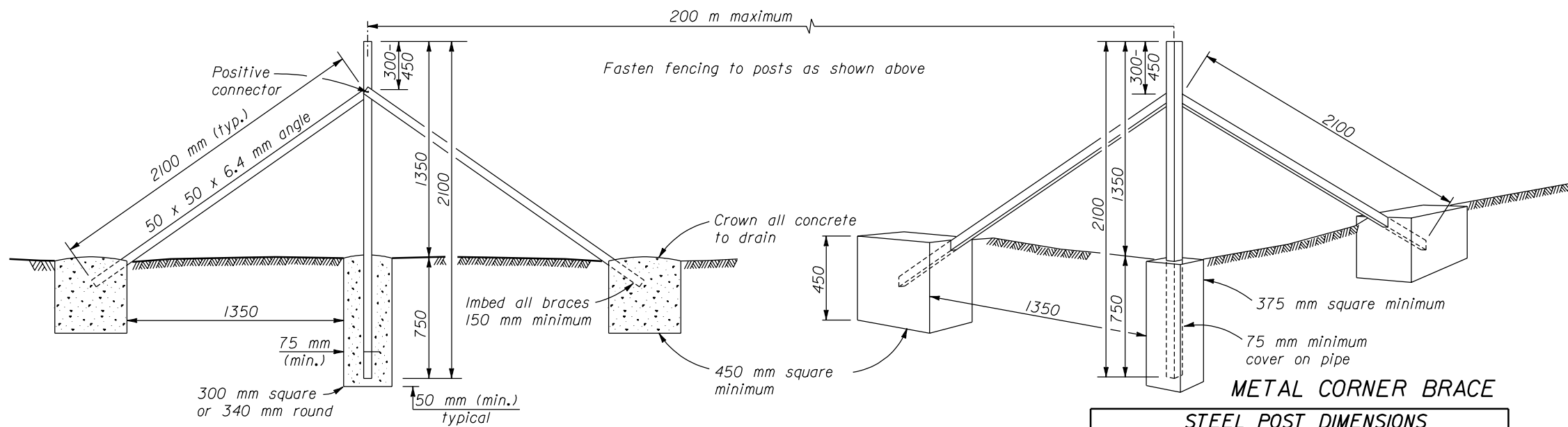

METAL LINE BRACE

METAL CORNER BRACE

STEEL POST DIMENSIONS			
MEMBER	SHAPE	kg/m (min.) nominal	SIZE nominal
Line post	Tee, channel or U-bar	1.98	U.S. Comm. Std.
Brace	Round pipe	3.38	approx. 40 mm OD
	Angle	3.63	51 x 51 x 6.4 mm
Other posts	Round pipe	5.28	60.3 mm OD
	Angle	6.10	64 x 64 x 6.4 mm

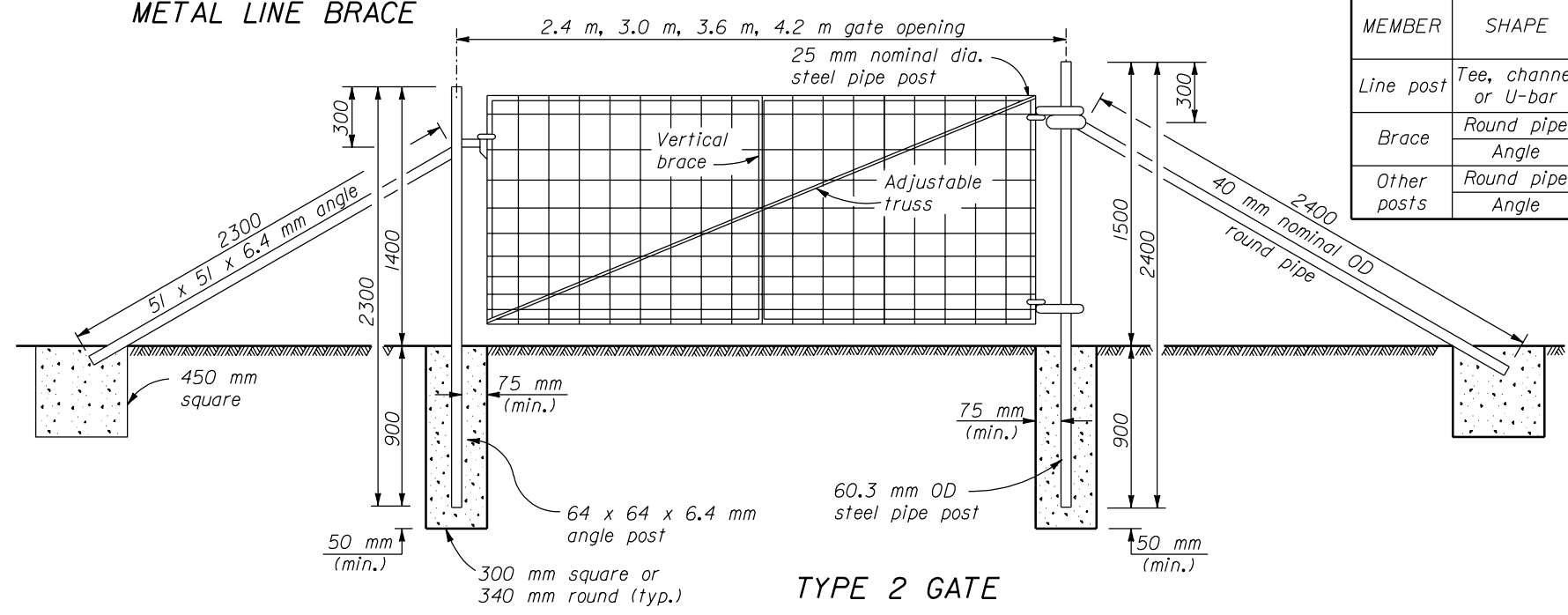

TYPE 2 GATE

NO SCALE

U.S. DEPARTMENT OF TRANSPORTATION
 FEDERAL HIGHWAY ADMINISTRATION
 WESTERN FEDERAL LANDS HIGHWAY DIVISION

METRIC DETAIL

**ALASKA
 WIRE FENCE AND GATE**

DETAIL APPROVED FOR USE 3/1996

REVISID: _____

DETAIL
WM619-40

f:\standraw\metric\details\wm61940.dgn 13 DEC 2000

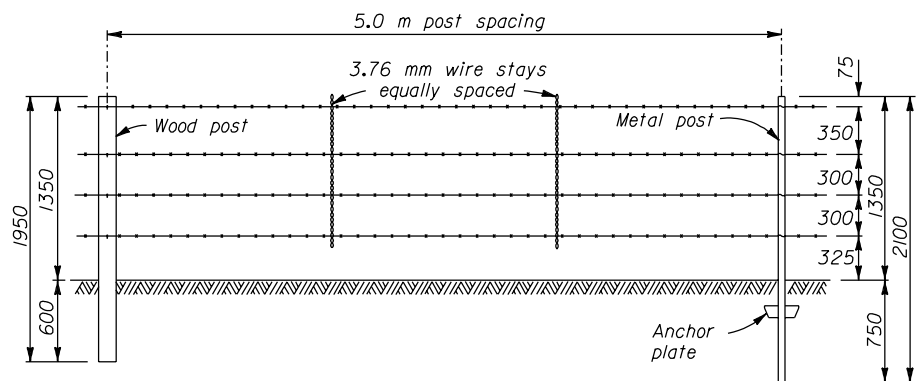

FENCE TYPE 1

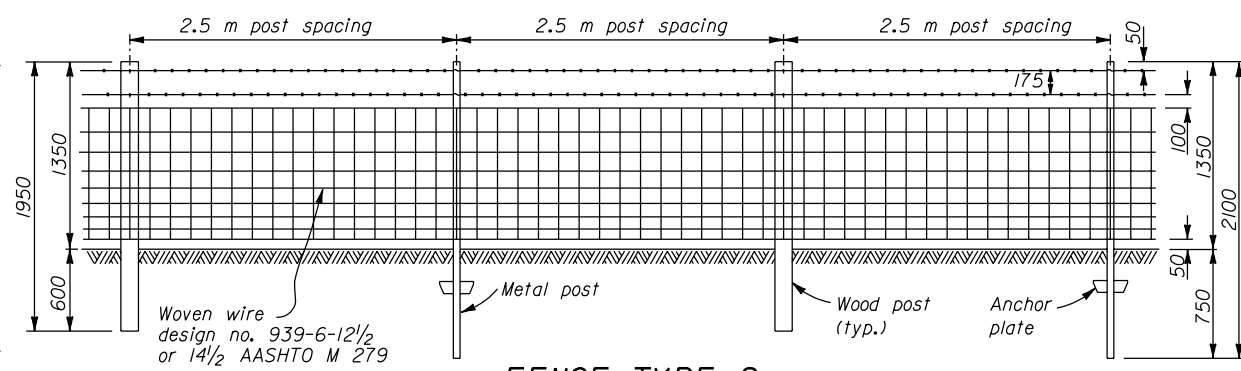

FENCE TYPE 2
(Wood and metal posts to be alternated)

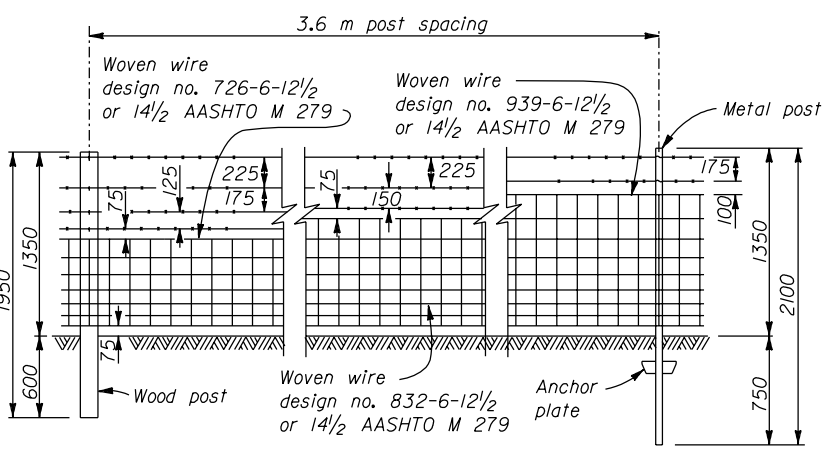

FENCE TYPE 3

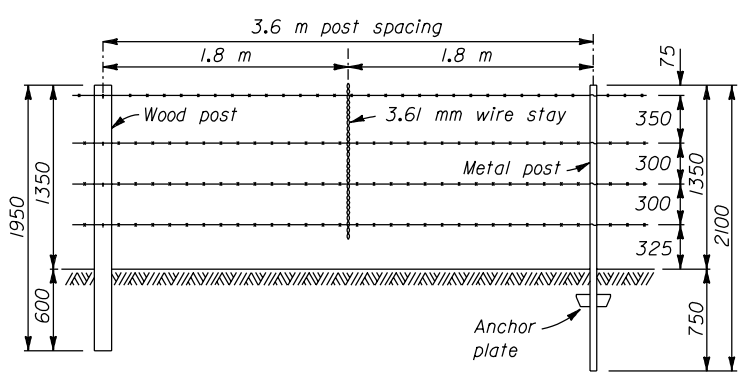

FENCE TYPE 5

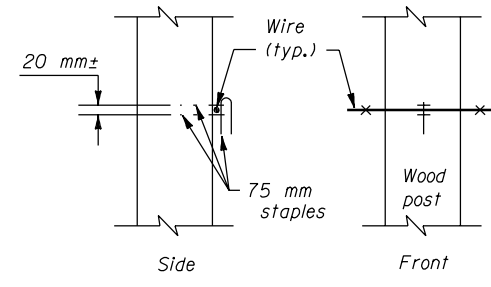

WOOD POST STAPLE DETAIL
(For drop fence Type 6)

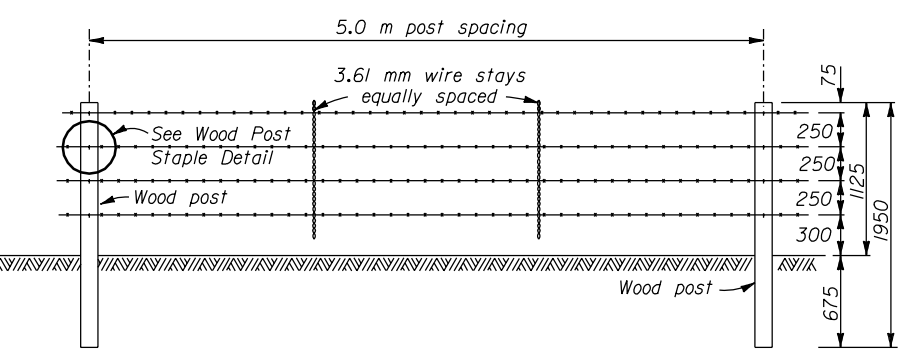

DROP FENCE TYPE 6

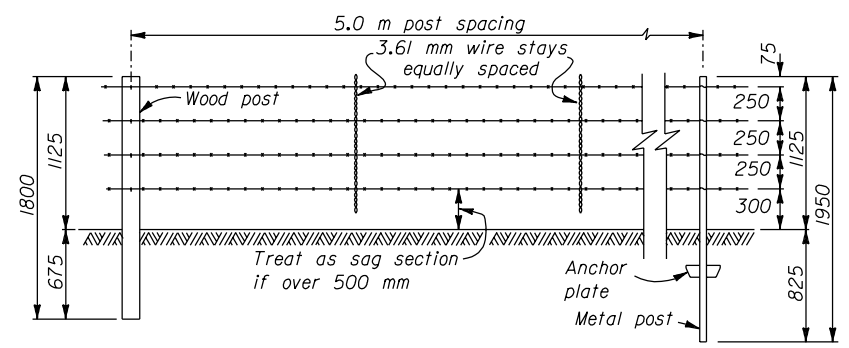

FENCE TYPE II

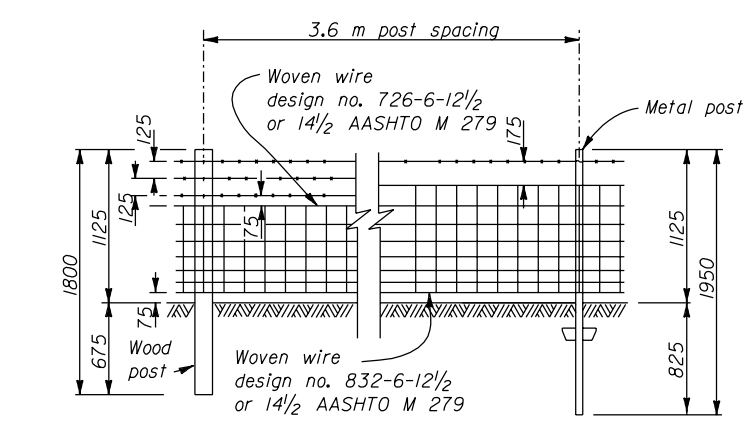

FENCE TYPE 33

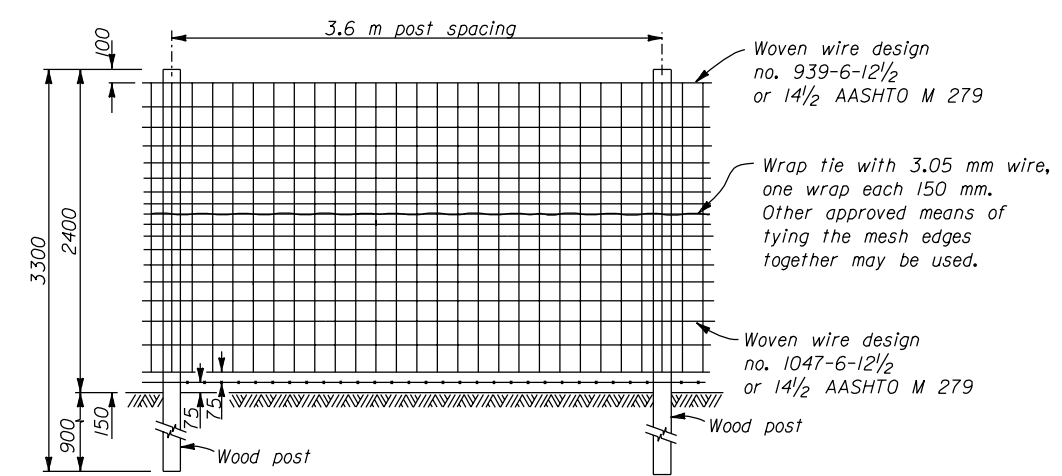

DEER-PROOF FENCE TYPE 8

- NOTE:**
- Dimensions not labeled are in millimeters.
 - Furnish either zinc coated (galvanized) or aluminum coated steel barbed wire.
 - Furnish either zinc coated (galvanized) or aluminum coated steel wire fence fabric of the design no. specified. If zinc coated fabric is furnished in 1.93 mm wire, coat the wire with a Class 3 coating.
 - Furnish 2.5l mm tie wire and wire clamps for fasteners in metal posts. Furnish 3.76 mm by 40 mm minimum length staples for wood post fasteners. Staple fence fabric on wood posts on alternate wires except in sag sections staple all wires to post. Use four wire clamps per post to attach fence fabric to steel posts. Use one wire clamp per wire per post on steel posts.
 - Furnish either painted or galvanized steel line posts. Furnish pressure treated Douglas fir, Western larch, Cedar, or pine of any species for wood line posts. Provide wood line posts with a minimum post circumference of 250 mm and a minimum distance between opposite faces of 75 mm. Treat the posts with pentachlorophenol, ACZA, or CCA, Type I, A, B, or C.

U.S. DEPARTMENT OF TRANSPORTATION
FEDERAL HIGHWAY ADMINISTRATION
WESTERN FEDERAL LANDS HIGHWAY DIVISION

METRIC DETAIL

IDAHO
RIGHT-OF-WAY FENCES

DETAIL APPROVED FOR USE 3/1996

REVISID: _____

DETAIL
WM619-50

NO SCALE

13 DEC 2000 f:\standrow\metric\details\wm61950.dgn

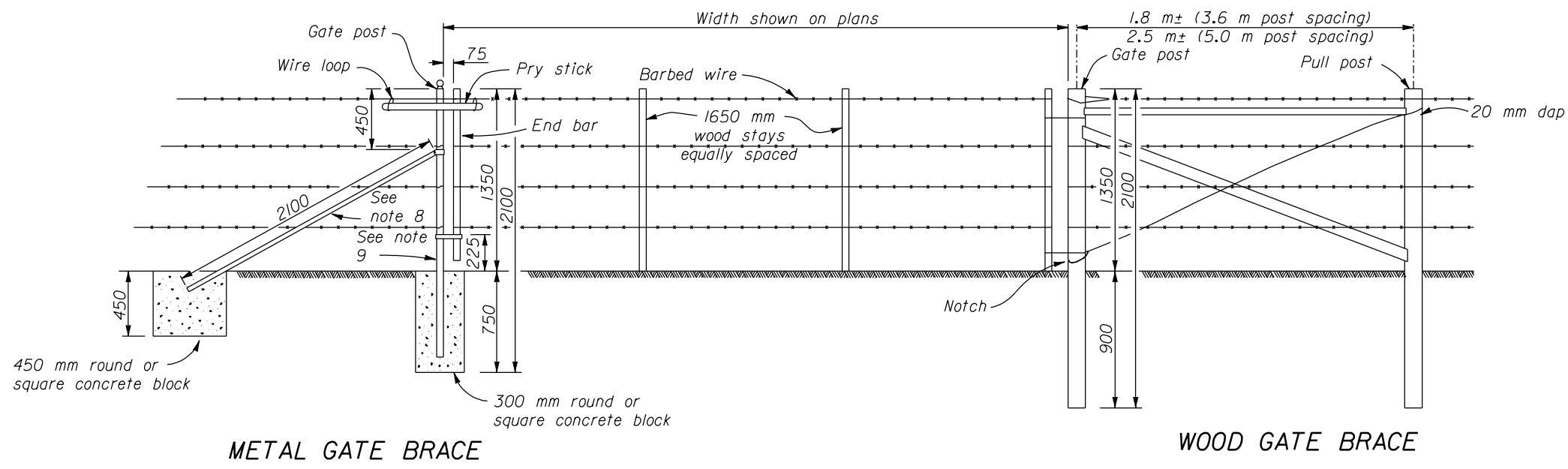

TYPE 1 GATE

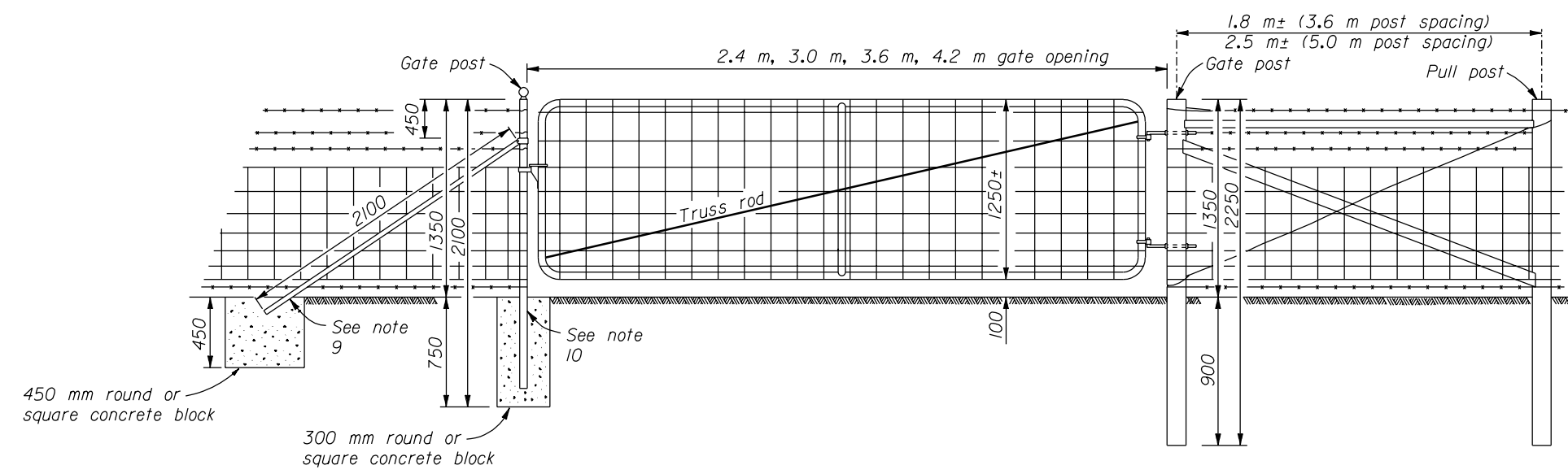

TYPE 2 GATE

NOTE:

- Dimensions not labeled are in millimeters.
- Match Type 1 gates with the adjacent fence.
- Hang gates on standard metal or wood brace posts corresponding with the type of posts used in adjacent line fence.
- Construct end post for Type 1 gate with a section of metal fence post or a round wood post 65 mm to 75 mm diameter. Provide a 600 mm length of hardwood tool handle for the pry stick. Use 3.76 mm wire for loop wire and pry stick wire or a suitable chain and adjust for length so that the gate will be neat and taut when closed. Place two wood stays, equally spaced, on each gate. Provide 50 mm minimum diameter or 40 mm square stays. Staple or tie wires to the stays and end posts.
- Form Type 2 gate frames with 33.40 mm OD cold rolled or drawn galvanized steel tubing with a wall thickness of 2.41 mm or with 25 mm galvanized standard steel pipe. Equip each gate with one standard adjustable diagonal truss rod from corner to corner. Provide galvanized malleable iron or steel hinges and two way self closing latch.
- Form metal walk gate frames with 26.67 mm OD cold rolled or drawn galvanized steeltubing with a wall thickness of 2.41 mm or with 19.05 mm galvanized standard steel pipe. Construct metal walk gates similar to Type 2 gate but omit vertical brace and truss.
- Approved alternate gates may be used.
- Where a single opening requires two gates, provide an approved drop bar, latch, chain and snap between the gates.
- 51 x 51 x 6.4 mm angle or 31.75 mm standard steel pipe brace.
- 64 x 64 x 6.4 mm angle or 64 mm standard steel pipe post.

NO SCALE

U.S. DEPARTMENT OF TRANSPORTATION FEDERAL HIGHWAY ADMINISTRATION WESTERN FEDERAL LANDS HIGHWAY DIVISION	
METRIC DETAIL	
IDAHO GATES	
DETAIL APPROVED FOR USE 3/1996	DETAIL
REVISED:	WM619-51

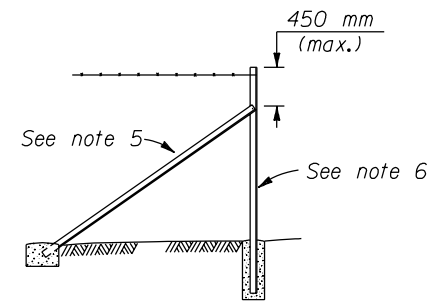

METAL END AND GATE BRACE

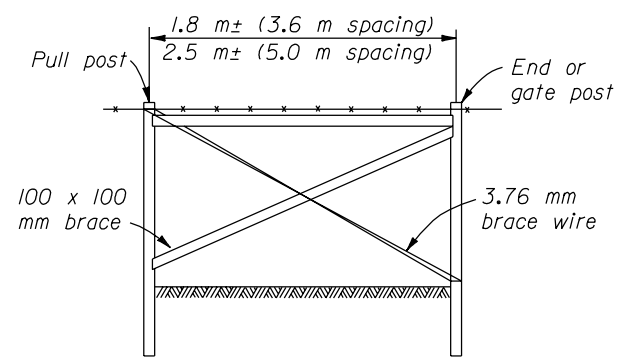

WOOD END AND GATE BRACE

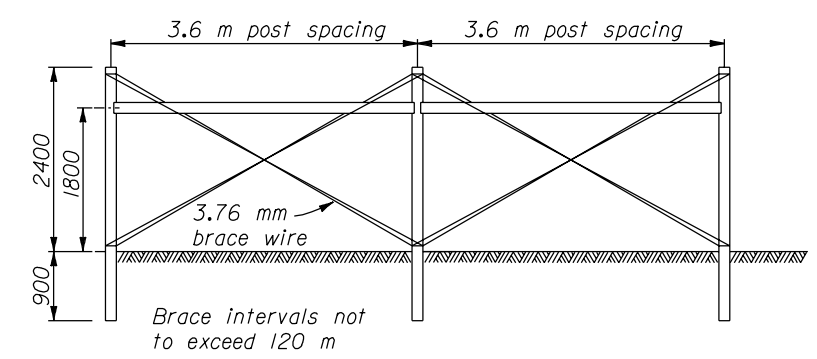

WOOD LINE BRACE FOR TYPE 8 FENCE

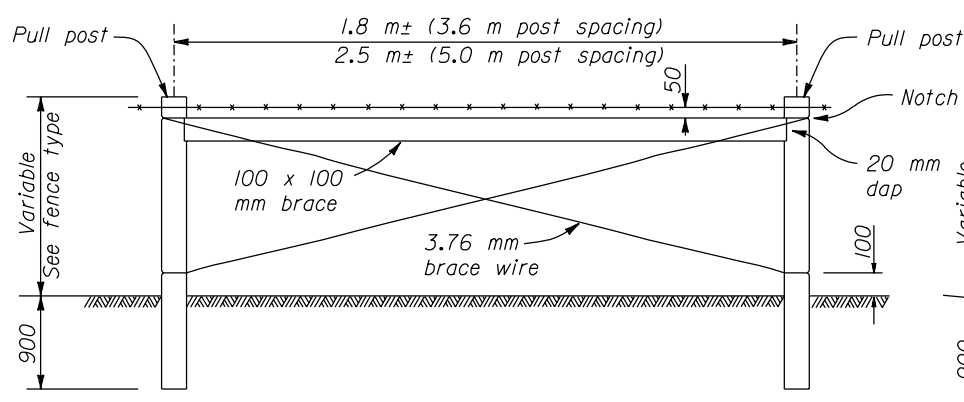

WOOD LINE BRACE

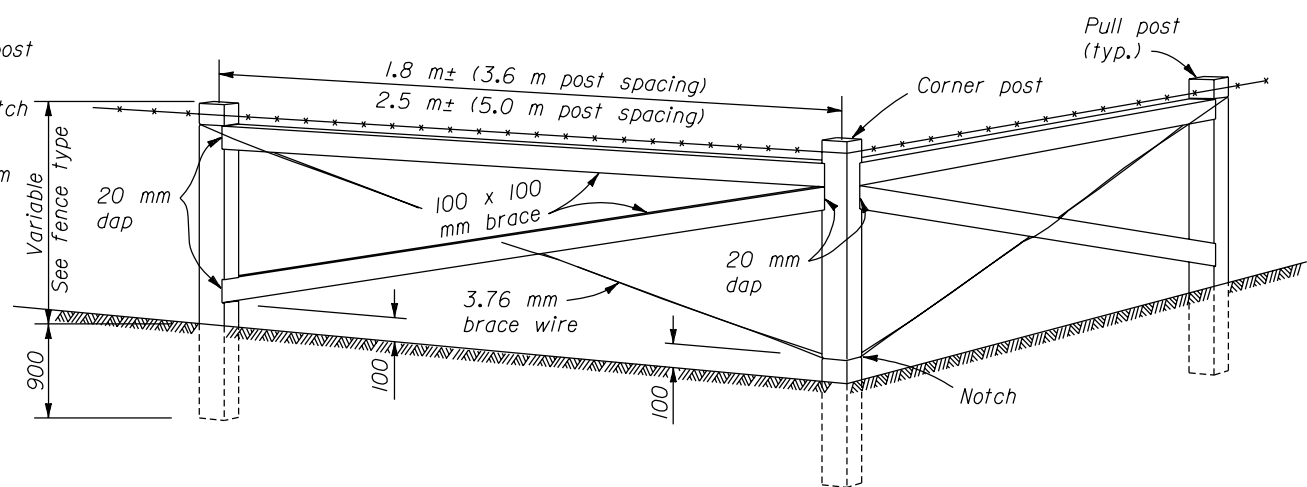

WOOD CORNER BRACE

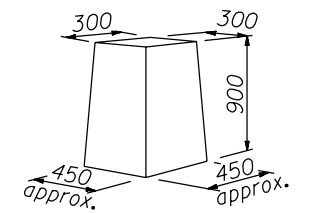

(not necessary to form)

ALTERNATE CONCRETE BLOCK

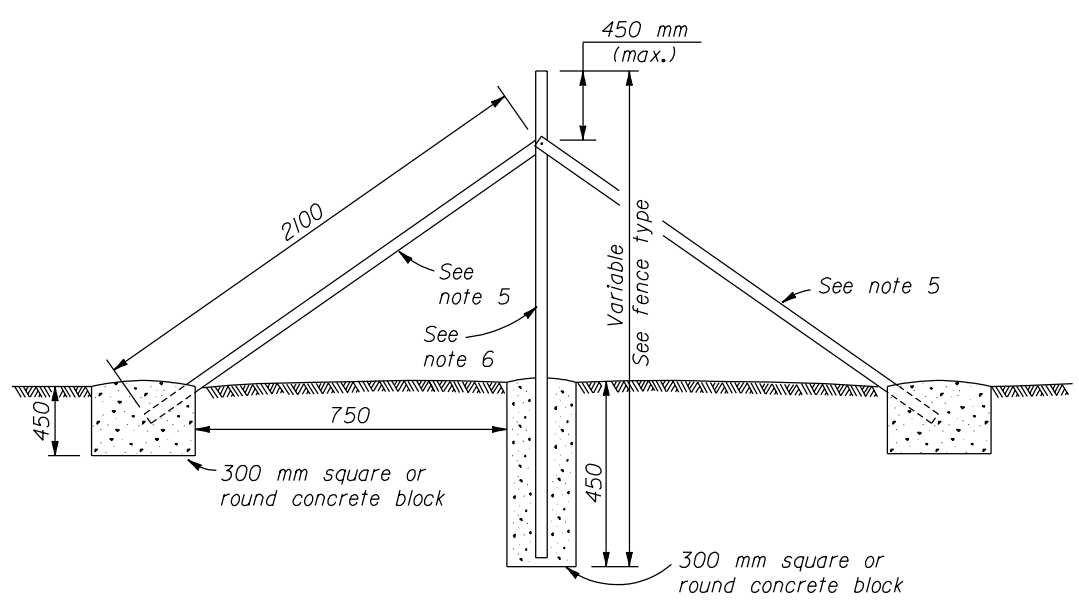

METAL LINE BRACE

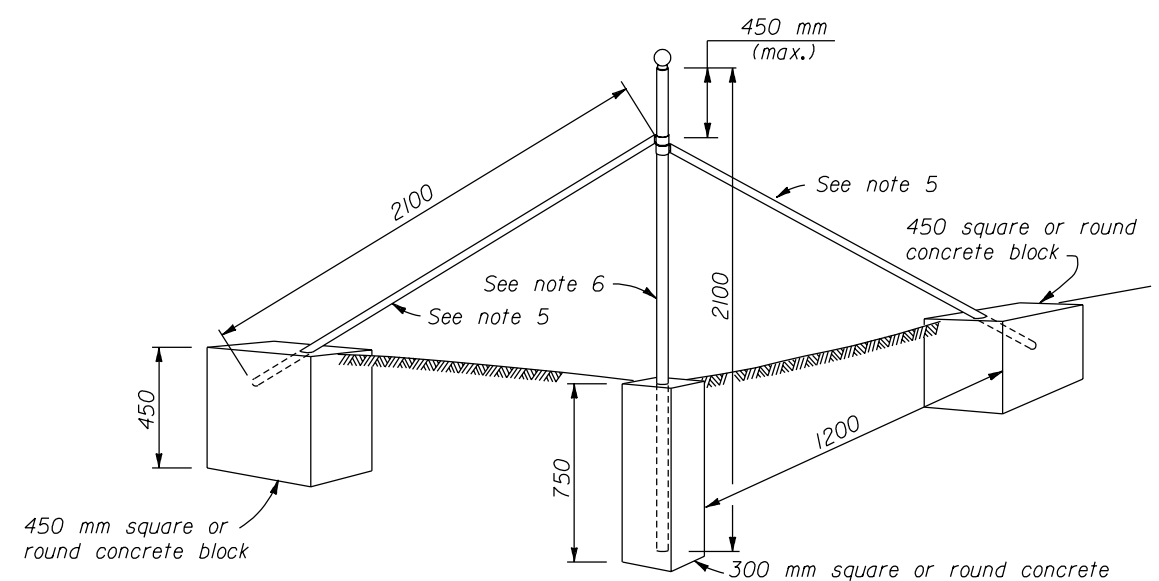

METAL CORNER BRACE

NO SCALE

NOTE:

1. Dimensions not labeled are in millimeters.
2. Furnish either painted or galvanized angles or galvanized steel round pipe posts for corner or line braces. Furnish round pipe posts with snug-fitting galvanized metal caps. Fabricate steel pipe fence posts and braces according to ASTM F 1083.
3. Furnish pressure treated Douglas fir, Western larch, Cedar, or Pine of any species for corner, pull, end or gate posts and braces. Provide posts with a minimum circumference of 444.5 mm and a minimum distance between opposite faces of 100 mm. Provide nominal 100 x 100 mm braces. Connect braces to post with three 16d nails or a 9.53 by 100 mm steel dowel. Treat the posts and braces with pentachlorophenol, ACZA, or CCA, Type I, A, B or C.
4. Where a fence ties into a bridge parapet or railing, the top of the fence shall not project above the top of the parapet or railing.
5. 51 x 51 x 6.4 mm angle or 31.75 mm standard steel pipe brace.
6. 64 x 64 x 6.4 mm angle or 64 mm standard steel pipe post.

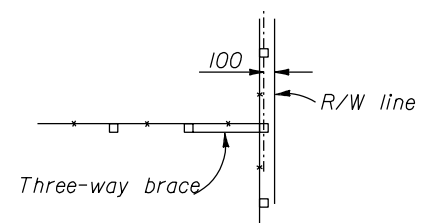

FENCE TERMINAL

U.S. DEPARTMENT OF TRANSPORTATION FEDERAL HIGHWAY ADMINISTRATION WESTERN FEDERAL LANDS HIGHWAY DIVISION	
METRIC DETAIL	
IDAHO FENCING BRACES	
DETAIL APPROVED FOR USE 3/1996	DETAIL
REVISED:	WM619-52

13 DEC 2000 f:\standrow\metric\details\wm61952.dgn

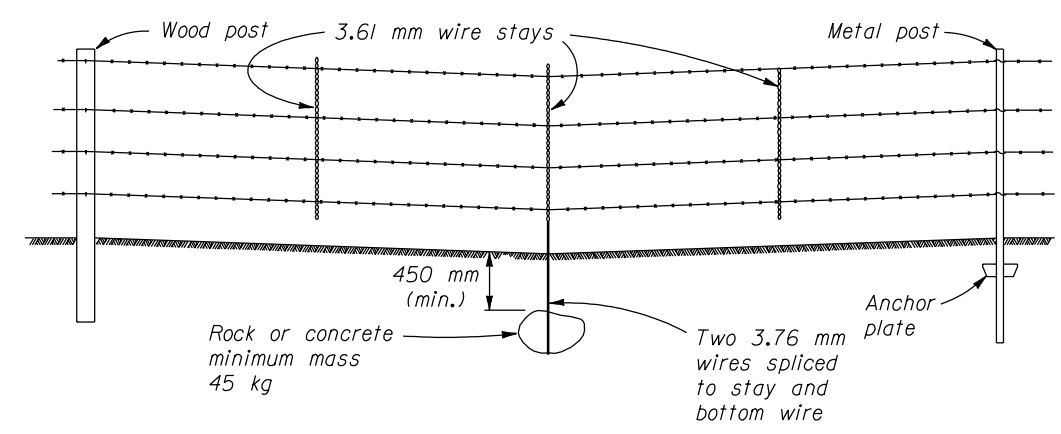

TYPICAL SAG SECTION - BARBED WIRE FENCES

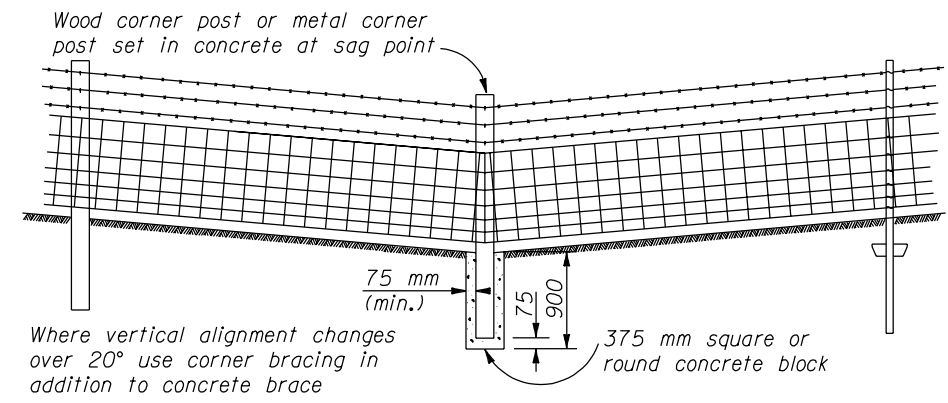

TYPICAL SAG SECTION FOR WOVEN WIRE, MESH OR COMBINATION FENCES

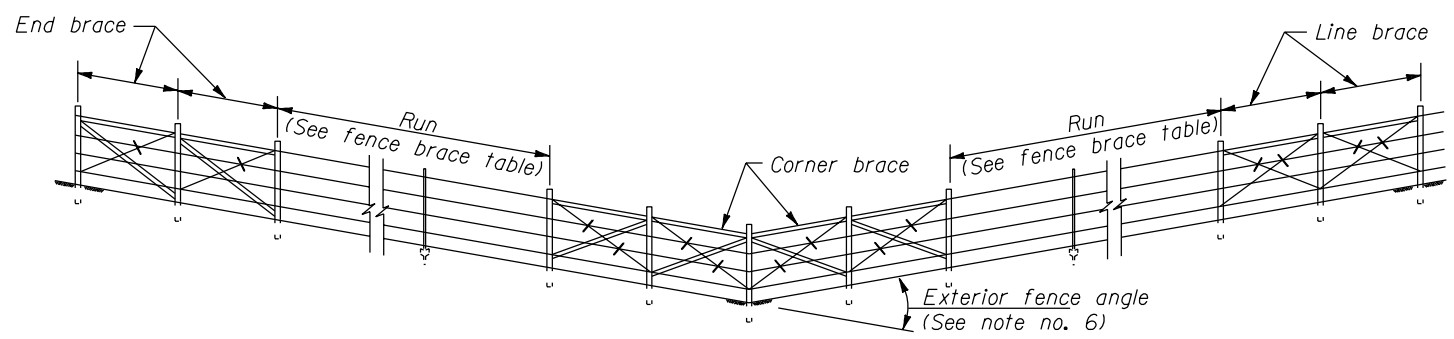

DOUBLE BRACE PANELS

FENCE TYPE	RUN IN METERS	WOOD PANELS REQUIRED	METAL BRACES
1, 5, 11, & 6	<20	NONE	NONE
	20 - 200	SINGLE	SINGLE
	200 - 300	DOUBLE	NOT ALLOWED
2, 3, & 33	<10	NONE	NONE
	10 - 100	SINGLE	SINGLE
	100 - 200	DOUBLE	NOT ALLOWED

NOTE:

- Dimensions not labeled are in millimeters.
- When a fence line approaches a ditch, gully, or depression, place the last post on level ground placed close enough to the edge of the drop-off that the wire may be strung to a post in the depression without touching the ground.
- When the depth of a depression on a Type 1, 5, or 11 fence exceeds the total vertical wire spacing over a maximum horizontal run of 2 spaces, an extra fence shall be constructed through the depression. Extra line braces and a deadman are included in this application. See the special applications for barbed wire detail.
- When a Type 1 gate is used in a special application as shown, extra line braces and the attached under timber, wire, and wire stays are included. The horizontal wires on the under timber are not to be stapled but wrapped around brace post, twice then around the wire itself.
- The special applications for barbed wire fences may be used for woven wire fence Types 2, 3, and 33 with approval or as directed. A Type 2 gate should be used with these fences. Barbed wire may be used through the depressions or etc., however the wires must match the woven wire spacing as nearly as possible. The under timber should not be attached directly to a Type 2 gate.
- When wood braces are used and the fence corner angle exceeds 30° in the exterior angle of the fence, use double panels on the corner brace. Install double panels for line and terminal braces according to the fence brace table.
- Use metal braces as shown in the metal brace details or the fence brace table.

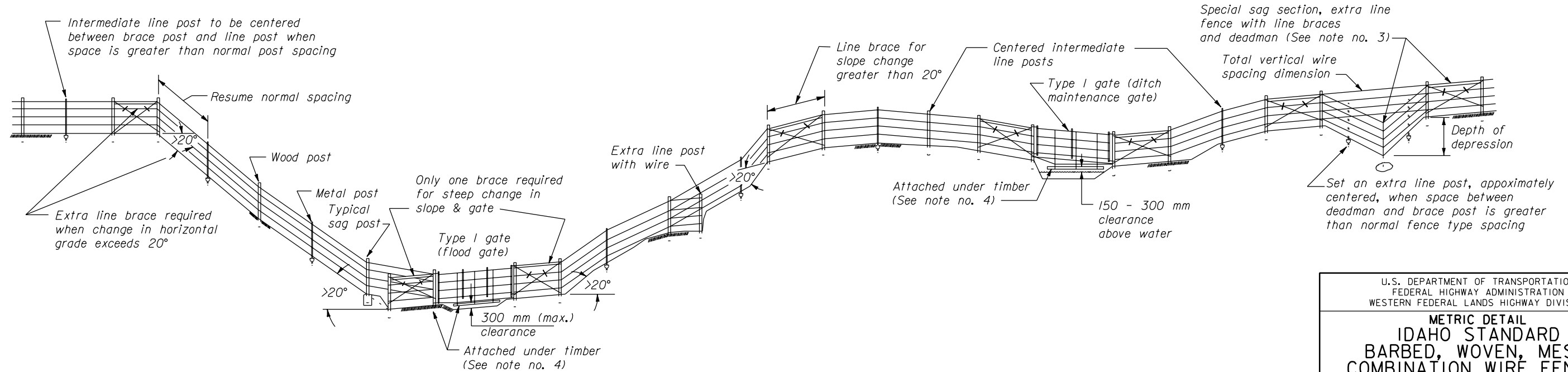

SPECIAL APPLICATIONS FOR TYPE 1, 5, & 11 BARBED WIRE FENCES

NO SCALE

U.S. DEPARTMENT OF TRANSPORTATION
 FEDERAL HIGHWAY ADMINISTRATION
 WESTERN FEDERAL LANDS HIGHWAY DIVISION

METRIC DETAIL
IDAHO STANDARD
BARBED, WOVEN, MESH,
COMBINATION WIRE FENCES
AND FENCING APPLICATIONS

DETAIL APPROVED FOR USE 3/1996
 REVISIONS: _____
 DETAIL WM619-53

13 DEC 2000 f:\standrow\metric\details\wm61953.dgn

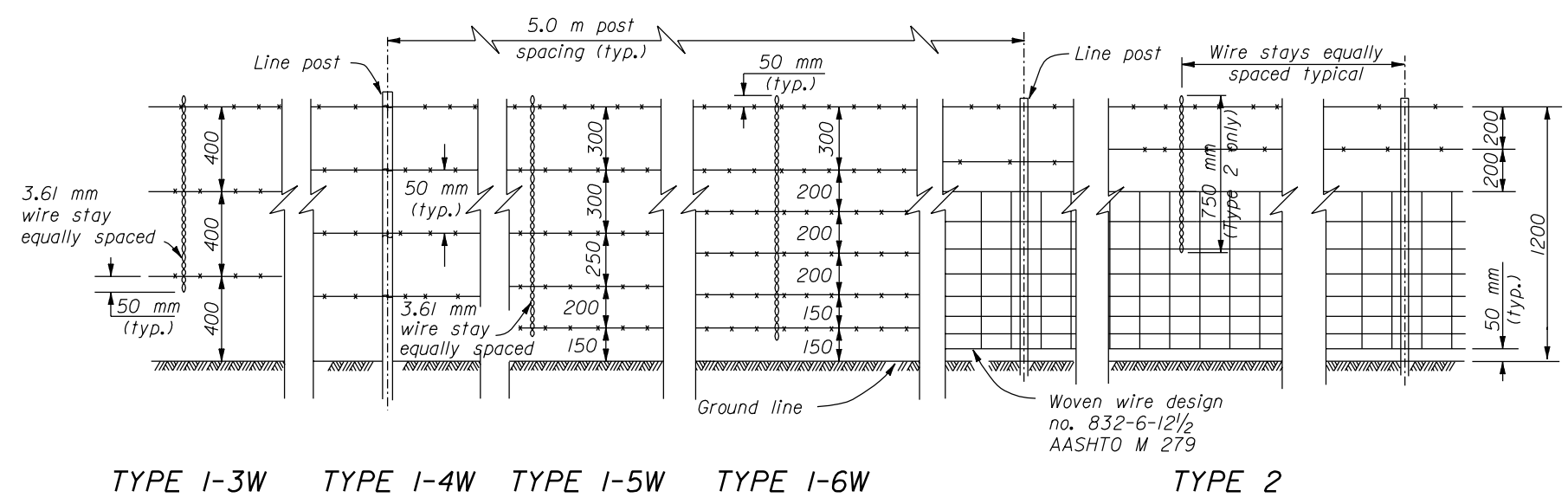

- NOTE:**
- Dimensions not labeled are in millimeters.
 - Furnish either zinc coated (galvanized) or aluminum coated steel barbed wire. Fabricate zinc coated barbed wire with a Class 1 zinc coating except on 1.70 mm strand wire use a Class 3 zinc coating. Provide either 2 point or 4 point barbs of 2.03 mm zinc coated wire. Fabricate aluminum coated barbed wire with 4 point barbs of 2.03 mm aluminum coated or aluminum alloy wire. Use strand wire with a minimum breaking strength of 430 kg.
 - Furnish 2.51 mm or heavier gage tie wire or wire clamps for fasteners in metal posts and 3.61 mm by 45 mm long wire staples of the barbed U-shape type for wood posts and wood stays. Galvanize wire stays, tie wire, wire loops, and wire clamps with a Class 1 zinc coating according to ASTM A 641.
 - Furnish either painted or galvanized steel fence posts, braces and anchor plates.
 - Fabricate metal fence stays from 3.61 mm wire twisted to form a 2-wire unit. Place stays halfway between posts. Use wire stays on all fences unless wood stays are specified. When specified, provide either 50 mm round, rough sawn 50x50 mm or 50x100 mm (S4S) wood stays of sufficient length to be placed on the ground with the top of the stay extending 50 mm above the top wire. Attach each wire to the stay using wire staples.
 - Furnish Douglas fir, Western larch, Lodgepole or Ponderosa pine for fence posts, brace rails, and wood stays if applicable. Treat the posts and brace rails with pentachlorophenol, ACZA, or CCA, Type I, A, B, or C.

FENCES

MEMBER	WOOD		STEEL		
	ROUND	SQUARE	SHAPE	kg/m (min.)	SIZE
	Di. of small end (min.)	SIZE			
Line post	100	100x100	Tee, channel or U-bar	1.98	U.S. Comm. Standard
Brace	150	150x150	Angle	3.63	51x51x6.4 mm
Other posts	150	150x150	Angle	6.10	64x64x6.4 mm

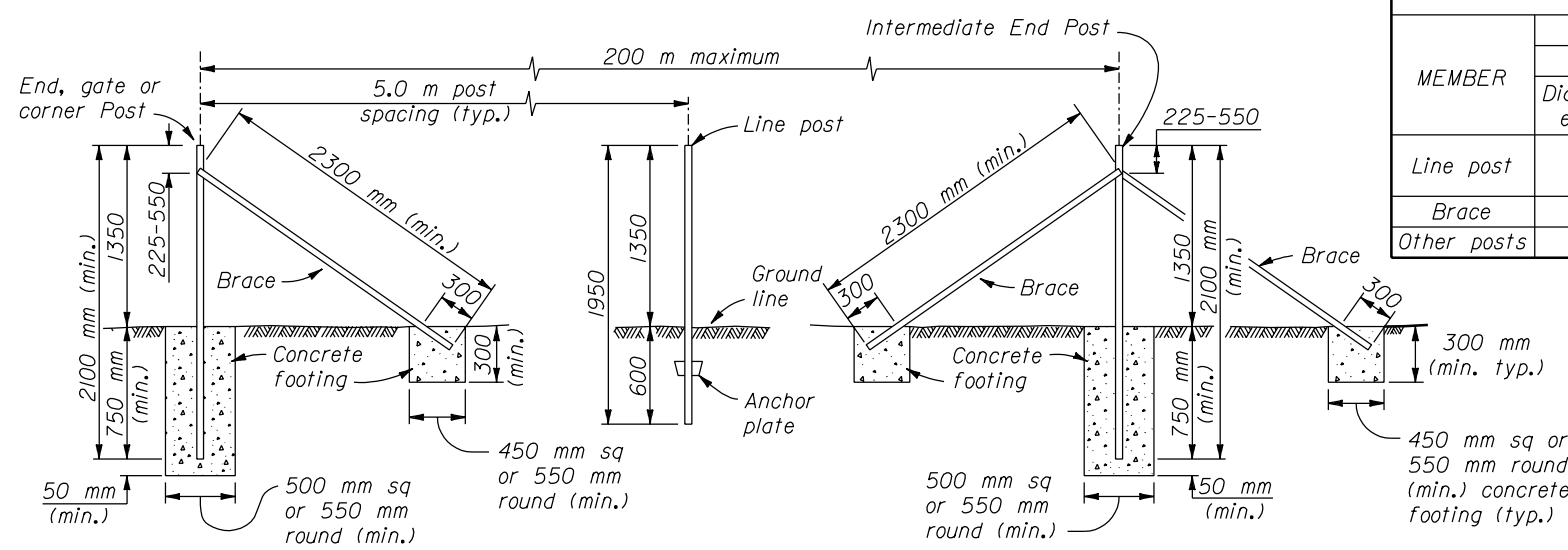

END, GATE OR CORNER BRACE

STEEL POSTS

LINE BRACE

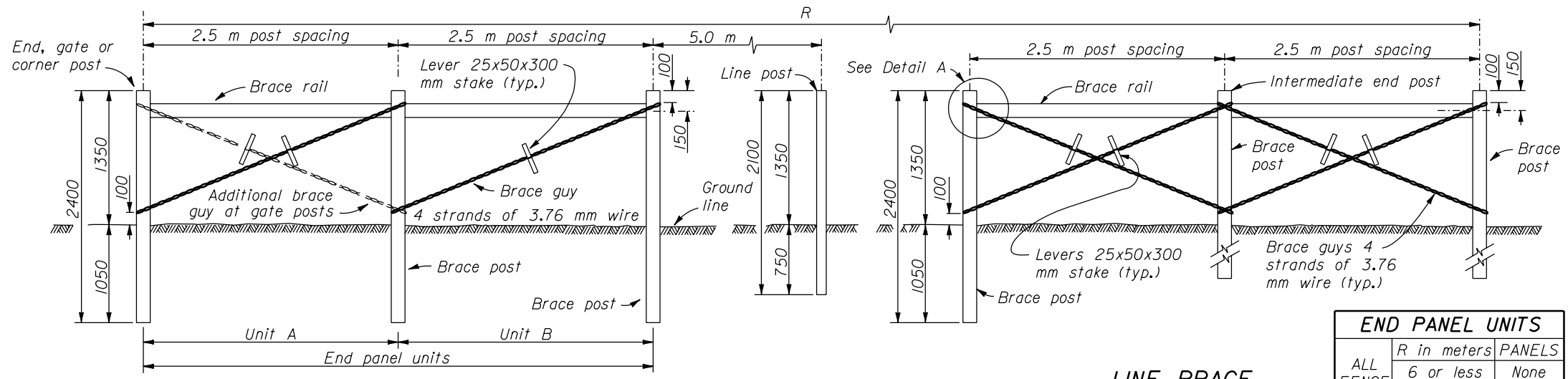

END, GATE OR CORNER BRACE

WOOD POSTS

LINE BRACE

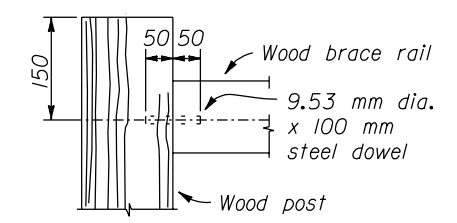

DETAIL A

END PANEL UNITS		
ALL FENCE TYPES	R in meters	PANELS
	6 or less	None
	6 - 100	A
	Over 100	A & B

NO SCALE

U.S. DEPARTMENT OF TRANSPORTATION
 FEDERAL HIGHWAY ADMINISTRATION
 WESTERN FEDERAL LANDS HIGHWAY DIVISION

METRIC DETAIL

MONTANA FENCE

DETAIL APPROVED FOR USE 3/1996
 REVISID: 5/2000

DETAIL
WM619-60

13 DEC 2000 f:\standrow\metric\details\wm61960.dgn

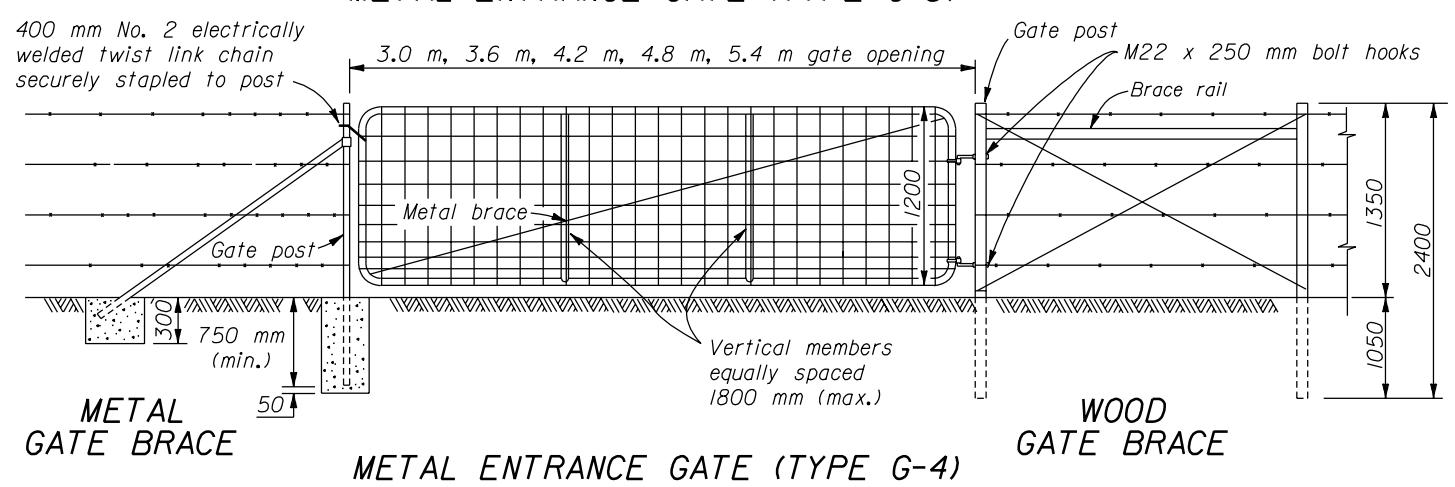
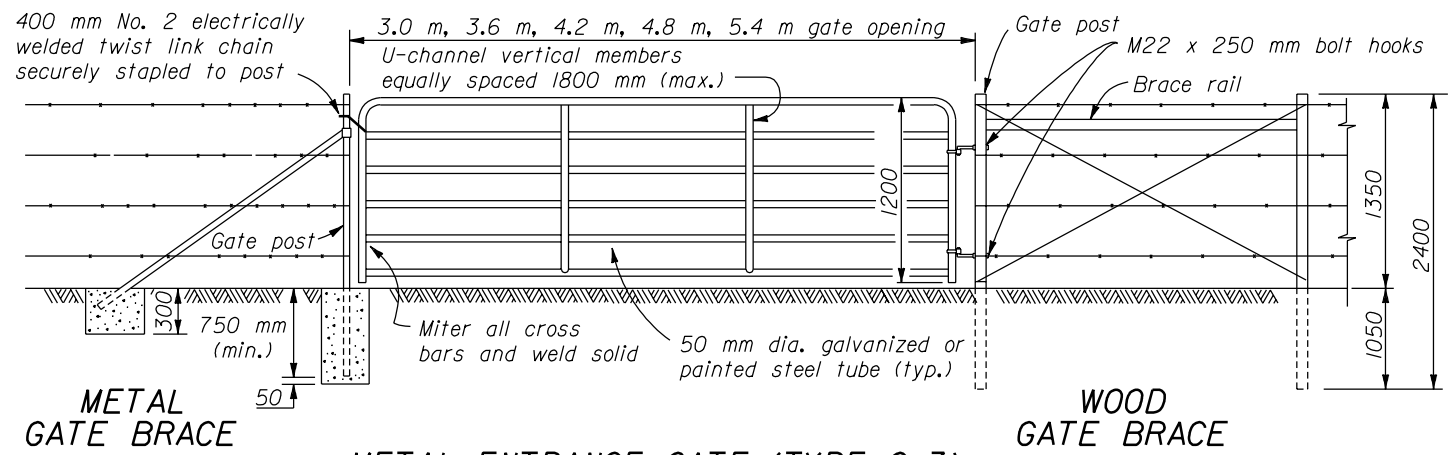
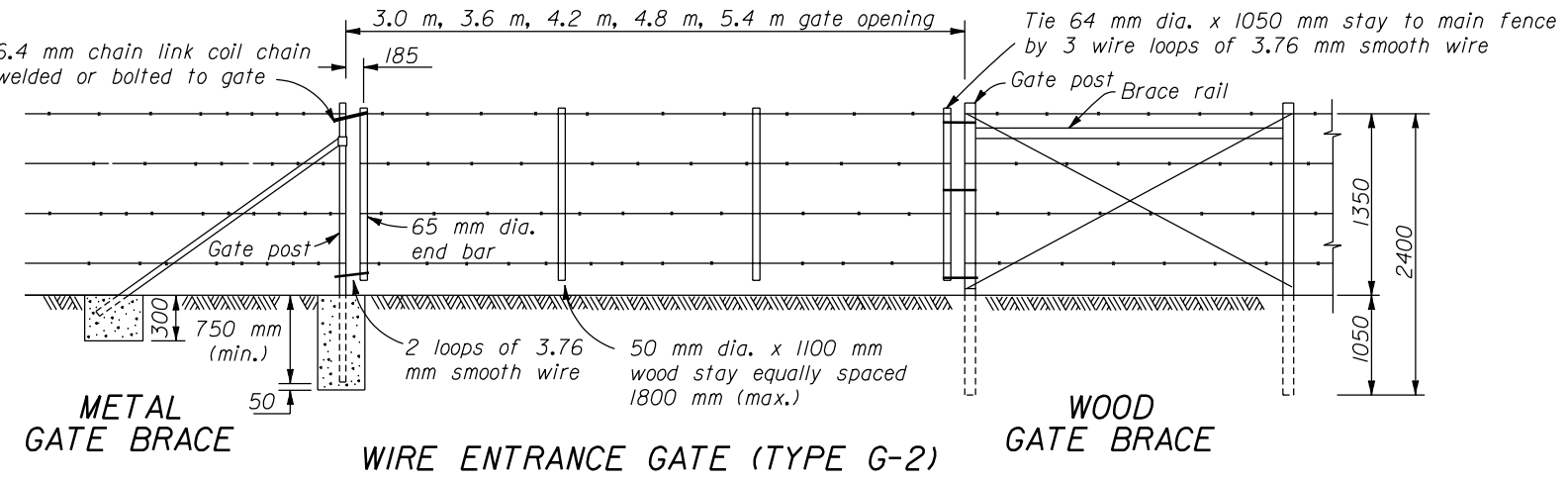
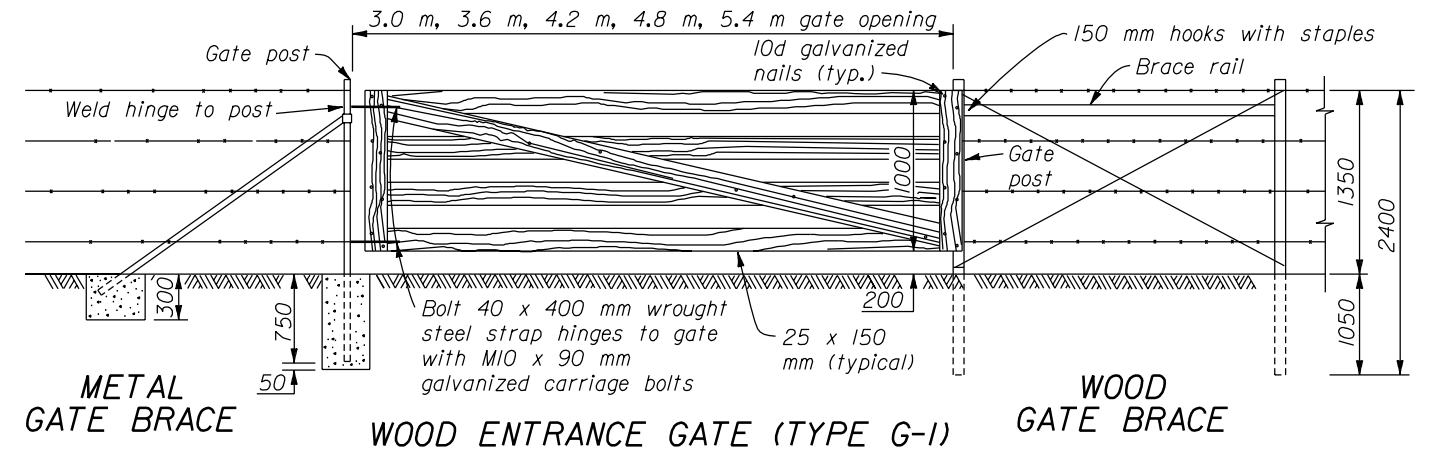

- NOTE:**
- Dimensions not labeled are in millimeters.
 - Furnish Douglas fir, Western larch, Lodgepole or Ponderosa pine for wood entrance fence and wood stays if applicable.
 - Match wire entrance gate with adjacent fence.
 - Furnish an approved commercial product for metal entrance gate (Type G-3). Galvanize all metal parts.
 - Manufacture metal entrance gate (Type G-4) of galvanized steel pipe not less than 25 mm nominal diameter (nominal mass 2.50 kg per linear meter) for frame and vertical braces. For each gate, provide two upright braces of the same material as the frame, spaced as 1/3 points in the gate. Place steel wire fence fabric conforming to design no. 1047-6-12 1/2 in AASHTO M 279 on the face of the gate. Equip each gate with adjustable 9.53 mm diameter truss rod from corner to corner. Provide hinges and 2-way self closing latch of an approved rust proof malleable iron or steel.
 - Where a single opening requires two metal entrance gates, provide an approved drop bar and fastener between the gates.
 - Furnish hardware in the metric sizes shown. Equivalent imperial sizes may be used when metric sizes are not available.
 - Approved alternate gates may be used.

U.S. DEPARTMENT OF TRANSPORTATION
 FEDERAL HIGHWAY ADMINISTRATION
 WESTERN FEDERAL LANDS HIGHWAY DIVISION

METRIC DETAIL

MONTANA
ENTRANCE GATES

DETAIL APPROVED FOR USE 3/1996

REVISIONS:

DETAIL
 WM619-61

NO SCALE

13 DEC 2000 f:\standrow\metric\details\wm61961.dgn

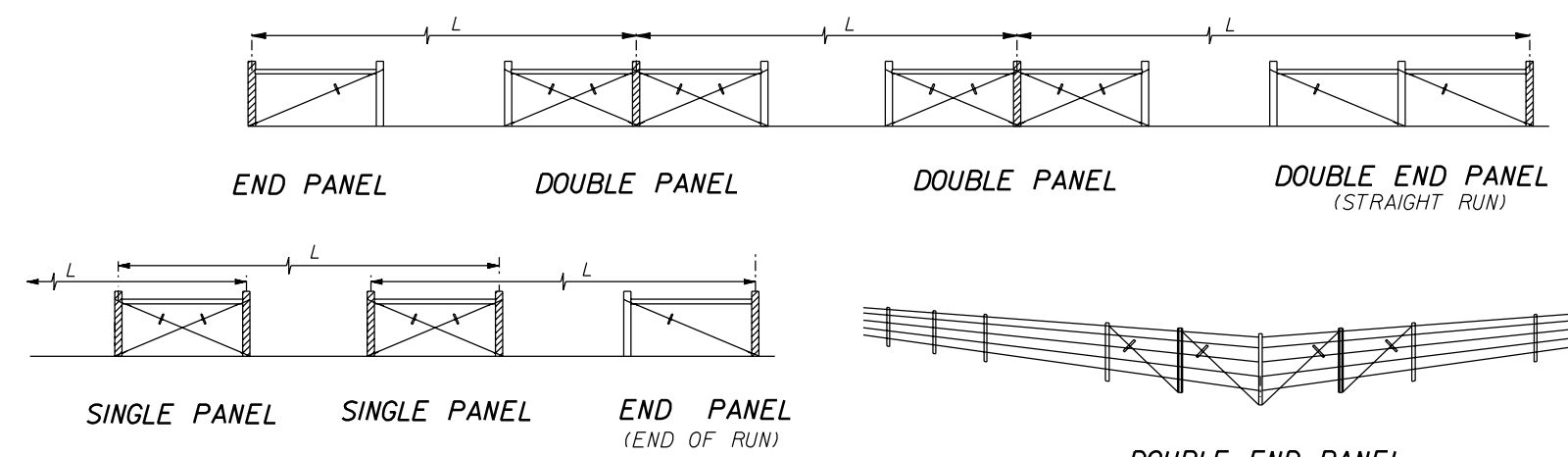

FENCE TYPE	RUN-L in meters	PANELS REQUIRED
COMBINATION WOVEN/BARBED	10 or less	None
	10 - 100	Single or end
BARBED	100 - 200	Double
	20 or less	None
	20 - 200	Single or end
	200 - 300	Double

NOTE:
Use double end panels only when the angle is greater than 30° and the run requires a double panel.

- NOTE:**
- Dimensions not labeled are in millimeters.
 - Attach barbed wires to tie off posts by wrapping around the post at least two times then wrap wires around itself five times.
 - To attach woven wire to tie off end post remove two or three vertical stay wires from the end of the fence. Place first complete vertical stay wire against post. Start at middle of horizontal line wires and wrap around end post at least two times and then wrap wire around itself five times.

NOTE:
Tie off on all cross hatched posts. End panels require brace wires only in one direction.

DOUBLE END PANEL
(FOR ANGLES GREATER THAN 30° AND RUN GREATER THAN 100 m FOR WOVEN AND 200 m FOR BARBED.)

FENCE PANELS

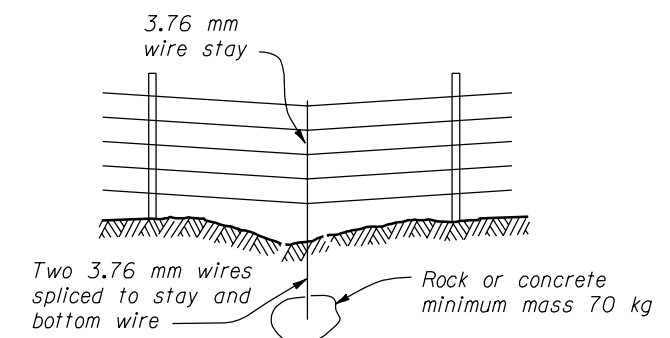
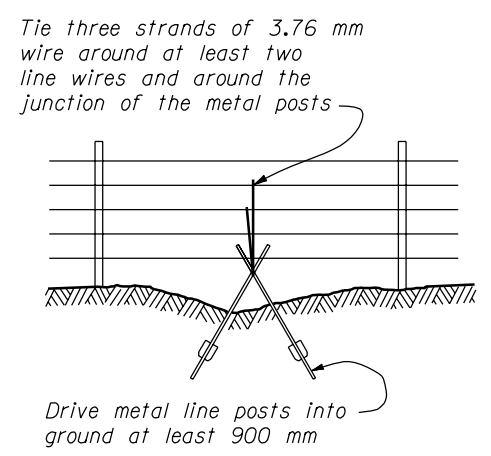

ALTERNATE DEADMAN

PRIMARY DEADMAN

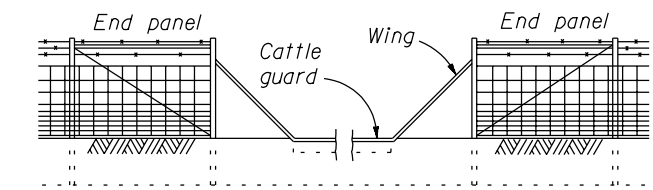

Fasten fence wire securely to the wings and arrange so that animals cannot pass

FENCE CONNECTION TO CATTLE GUARD

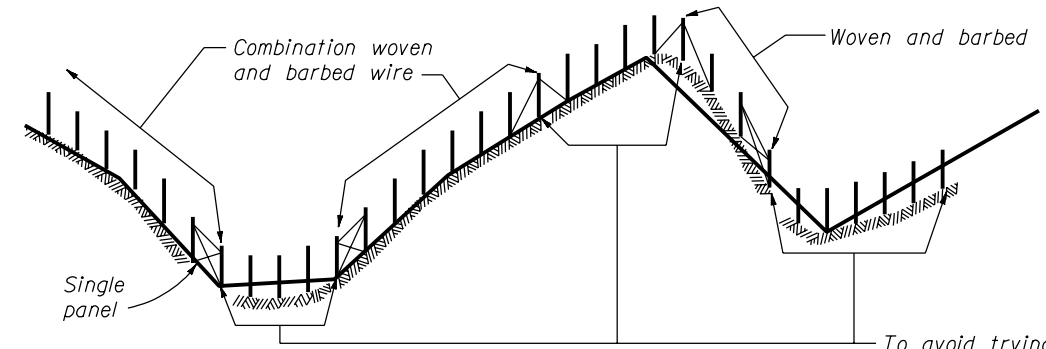

To avoid trying to conform woven wire to uneven terrain, space a minimum of 10 barbed wires spaced about the same as horizontal wire on combination.

FENCE LAYOUT ON SHARP VERTICAL CURVES

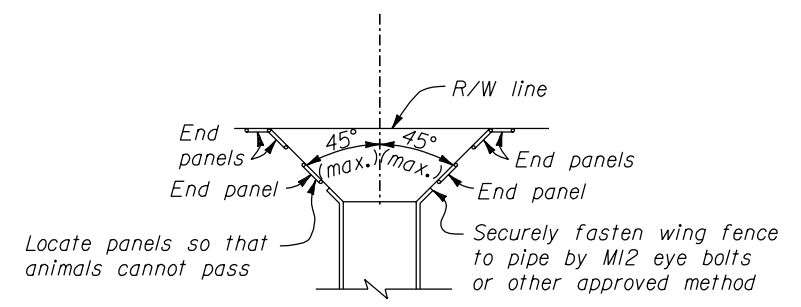

FENCE LAYOUT AT STOCKPASS

Locate panels so that animals cannot pass. Securely fasten wing fence to pipe by M12 eye bolts or other approved method.

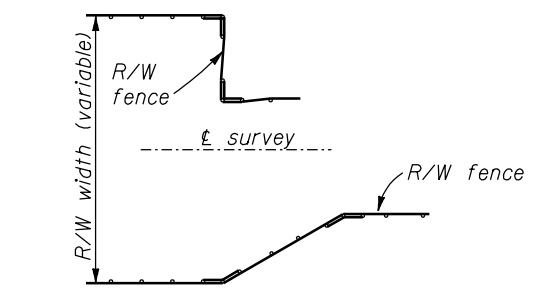

FENCE LAYOUT AT CHANGE IN R/W WIDTH

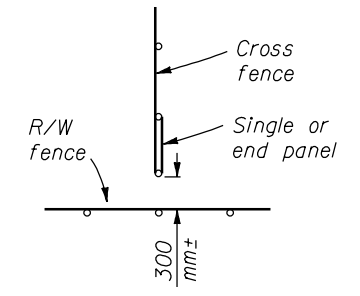

FENCE LAYOUT AT CROSS FENCE CONNECTION

NO SCALE

U.S. DEPARTMENT OF TRANSPORTATION
FEDERAL HIGHWAY ADMINISTRATION
WESTERN FEDERAL LANDS HIGHWAY DIVISION

METRIC DETAIL

MONTANA FENCING APPLICATIONS

DETAIL APPROVED FOR USE 3/1996
REVISOR: _____

DETAIL
WM619-62

13 DEC 2000 f:\standrow\metric\details\wm61962.dgn

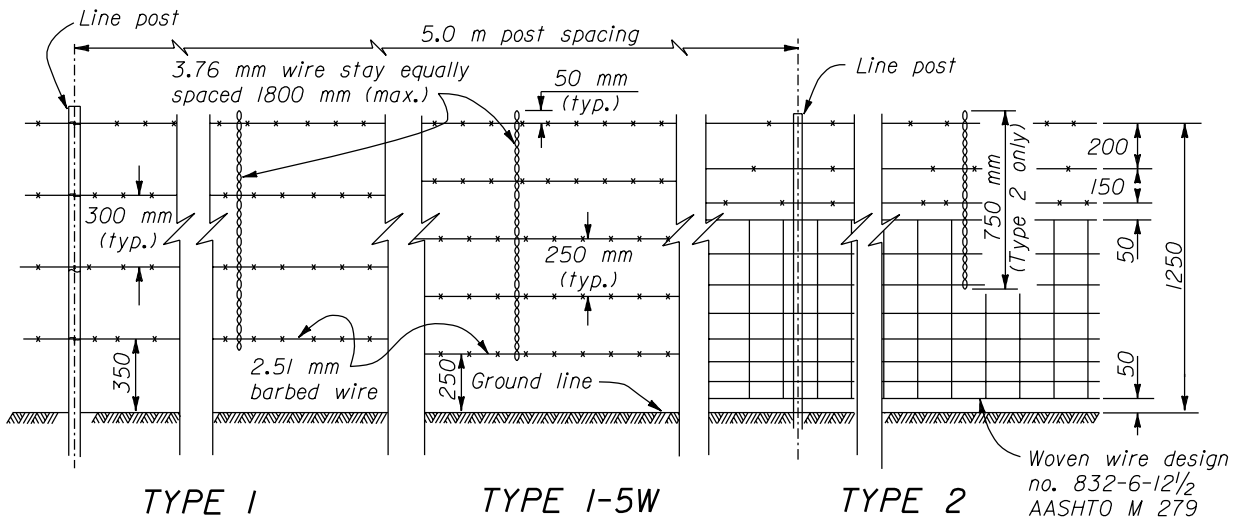

MEMBER	WOOD		STEEL			
	ROUND	SQUARE	SHAPE	kg/m (min.)	SIZE	
	dia. of small end min.-max.	min. avg. nominal				
Line post	75-100	75	75x75	1.98	U.S. Comm. Standard	
Brace	40-140	100	100x100	Round pipe	3.38	approx. 40 mm OD
				Angle	3.63	51x51x6.4 mm
Other posts	100-175	125	125x125	Round pipe	5.43	60.3 mm OD
				Angle	6.10	64x64x6.4 mm

- NOTE:**
- Dimensions not labeled are in millimeters.
 - Furnish either zinc coated (galvanized) or aluminum coated steel barbed wire. Fabricate zinc coated barbed wire from two strands of 2.51 mm steel wire with a Class 3 zinc coating and 2 point or 4 point barbs of 2.03 mm zinc coated wire. Fabricate aluminum coated barbed wire from two strands of 2.51 mm aluminum coated steel wire with 4 point barbs of 2.03 mm aluminum coated or aluminum alloy wire.
 - Furnish either zinc coated (galvanized) or aluminum coated steel wire fence fabric. If zinc coated fabric is furnished, use Grade 60 fabric with a Class 1 coating.
 - Furnish 3.05 mm tie wire or wire clamps for fasteners in metal posts. Galvanize wire stays, tie wire, wire loops, and wire clamps with a Class 1 zinc coating according to ASTM A 641.
 - Furnish either painted or galvanized steel fence posts for tee, channel or U bar shapes. Furnish galvanized steel round pipe or steel angle for posts and braces. Fit round pipe posts with snug-fitting galvanized metal caps. Fabricate steel line posts and angles from Type A steel conforming to AASHTO M 281. Fabricate steel pipe posts and braces according to AASHTO M 160.
 - Furnish Douglas fir, Western hemlock or Western pine for fence posts, brace rails, rock jacks, and wood stays. Treat the posts and brace rails with creosote, pentachlorophenol, ACZA, or CCA, Type I, A, B, or C.
 - Use 50x50x1300 mm minimum length wood stays in areas of heavy snowfall or drifting (over 900 mm). Rest stays firmly on the ground and space as shown for wire stays. Staple all barbed wires, and a minimum of 4 horizontal wires for woven wire fabric, where applicable.
 - Rock jacks are acceptable to support the fence across solid rock areas on lieu of posts embedded in concrete.

ROCK JACK LUMBER REQUIRED		
Post	1 each	100x150 x 1400 mm
Ground pieces	3 each	50x150 x 1200 mm
Platform	4 each	50x200 x 1200 mm
Diagonal brace	2 each	50x150 x 1500 mm

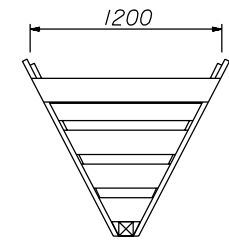

PLAN VIEW

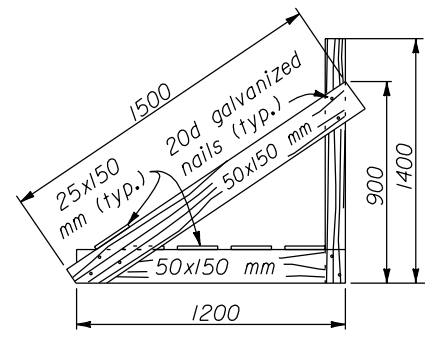

SIDE VIEW

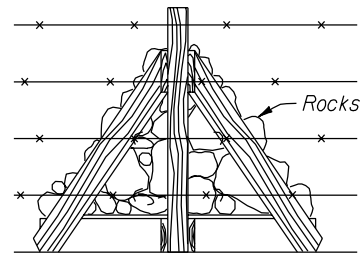

FRONT VIEW

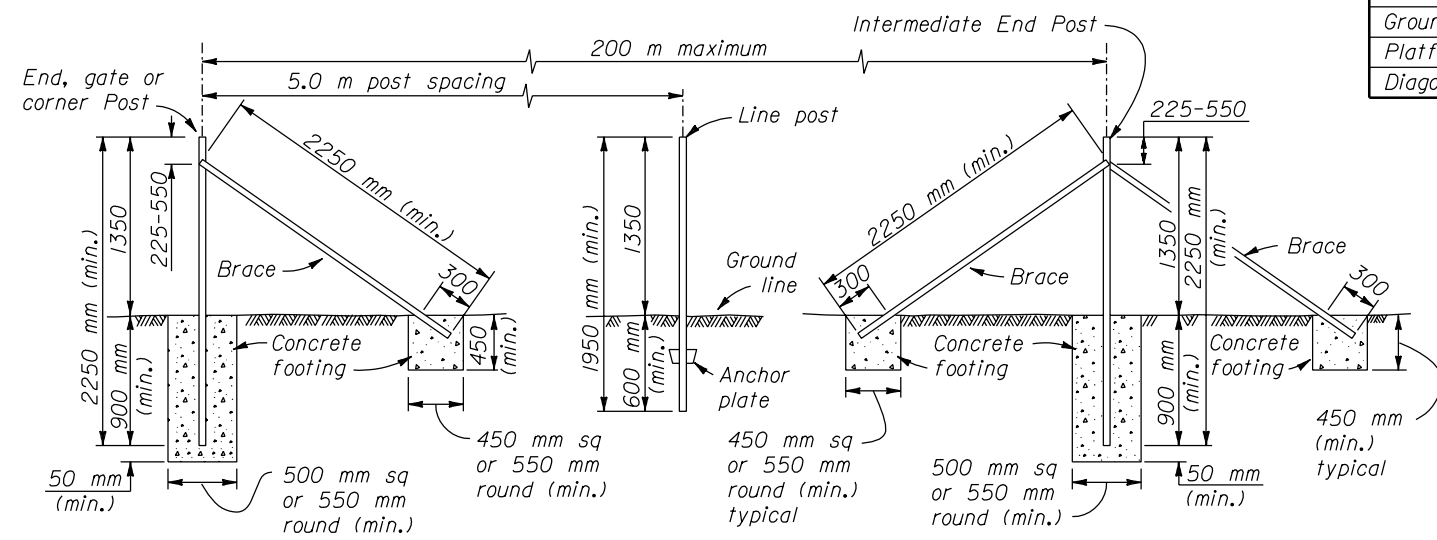

END, GATE OR CORNER BRACE

LINE BRACE

ROCK JACK

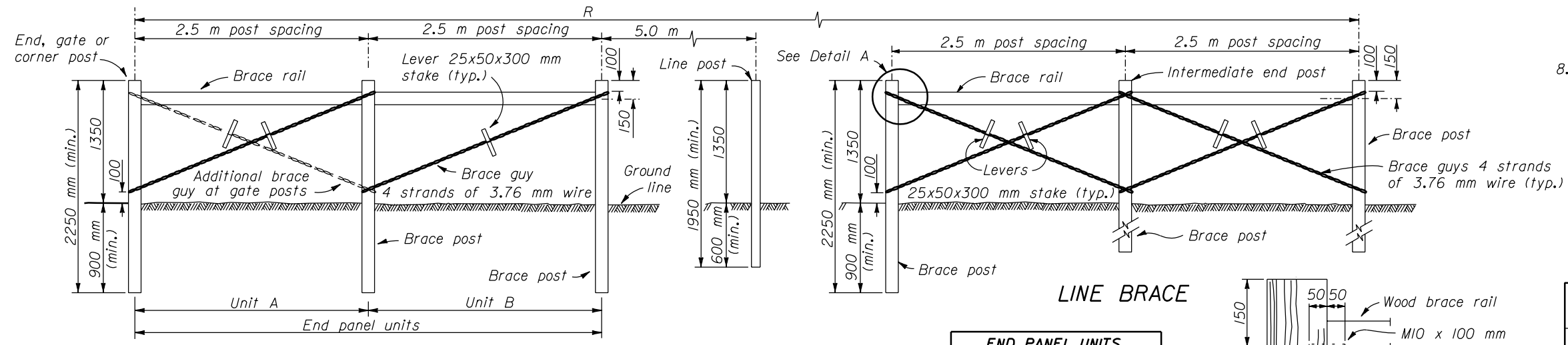

END, GATE OR CORNER BRACE

WOOD POSTS

LINE BRACE

END PANEL UNITS		
ALL FENCE TYPES	R	PANELS
	6 or less	None
	6 - 100	A
	Over 100	A & B

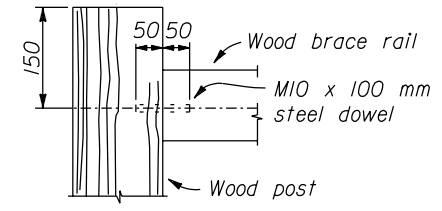

DETAIL A

NO SCALE

U.S. DEPARTMENT OF TRANSPORTATION
FEDERAL HIGHWAY ADMINISTRATION
WESTERN FEDERAL LANDS HIGHWAY DIVISION

METRIC DETAIL

**OREGON
RIGHT-OF-WAY FENCES**

DETAIL APPROVED FOR USE 3/1996

REVISID: _____

DETAIL
WM619-70

13 DEC 2000

f:\standrow\metric\details\wm61970.dgn

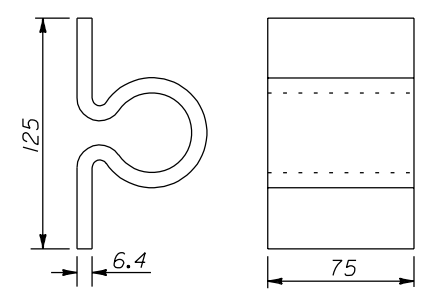
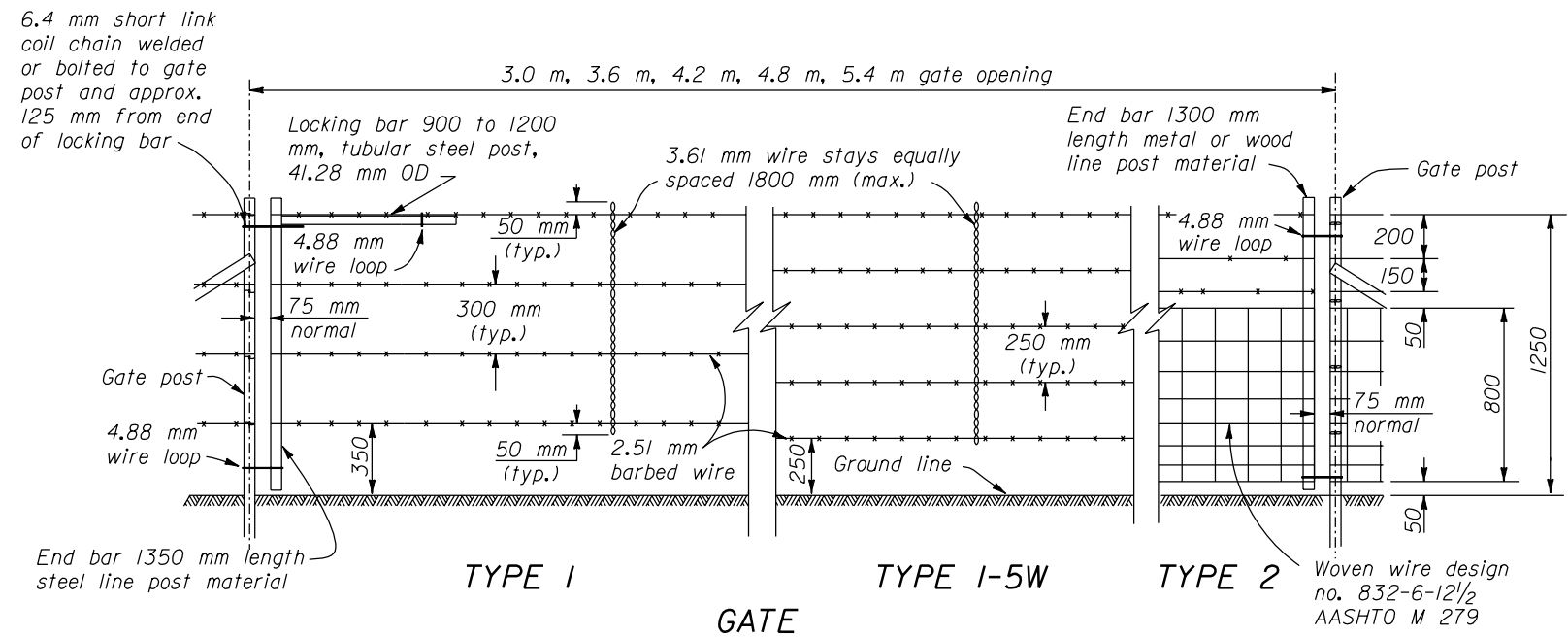

NOTE:
 1. Dimensions not labeled are in millimeters.
 2. Approved alternate gates may be used.

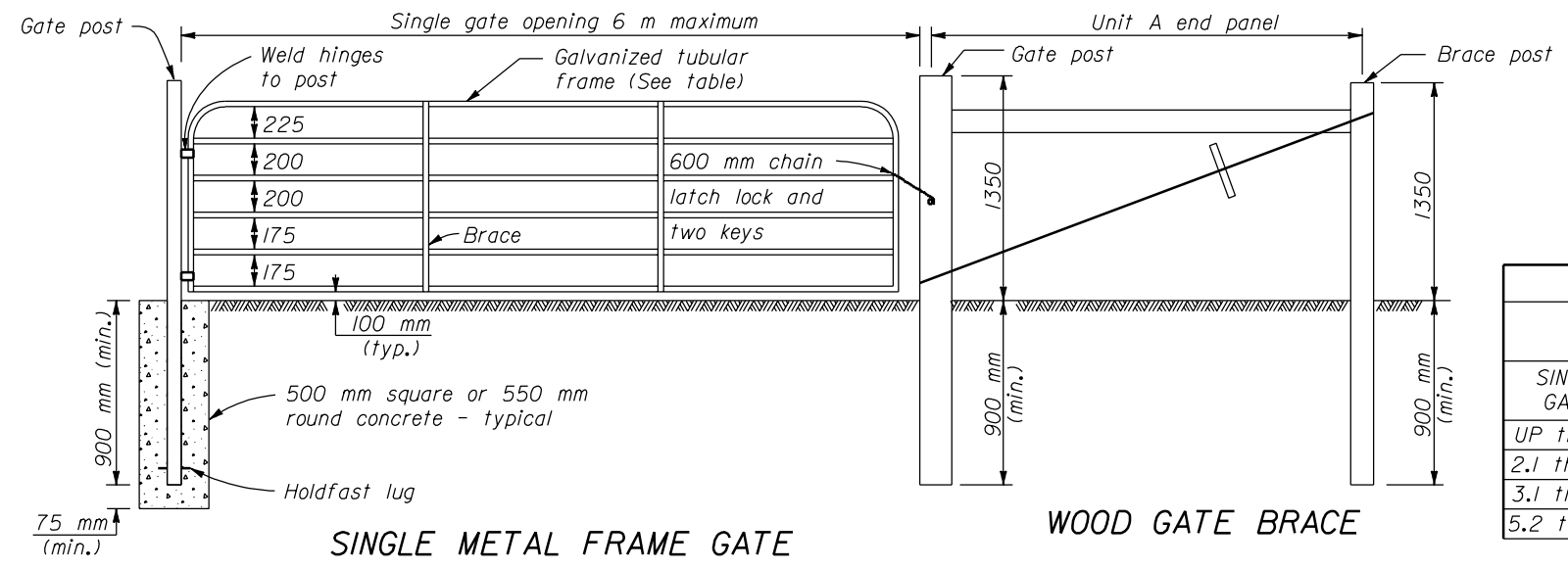
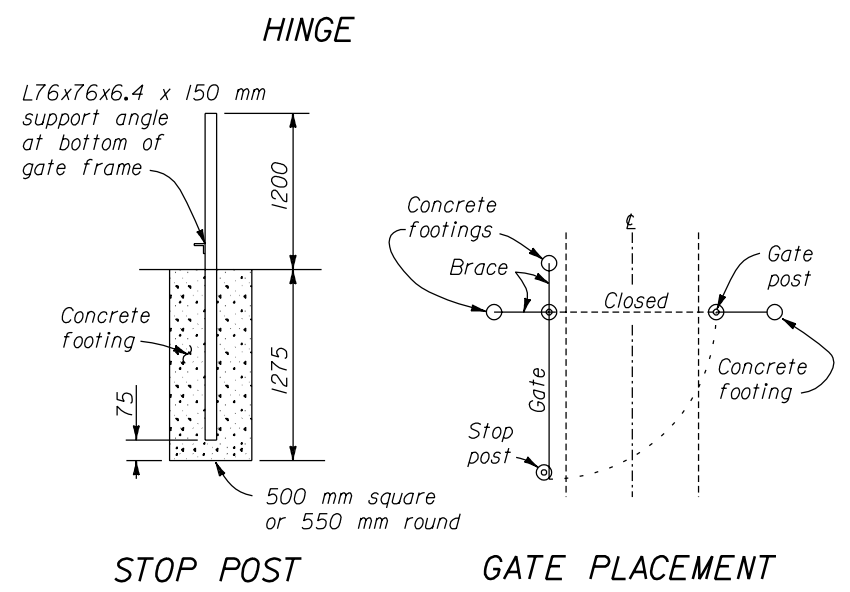

GATE COMPONENTS						GATE POSTS				
GATE OPENING IN METERS		TUBULAR FRAME		BRACES		WOOD		GALVANIZED STEEL		
SINGLE GATE	DOUBLE GATE	DIAMETER nominal	kg/m (min.)	NUMBER	DIAMETER nominal	ROUND		SQUARE	TUBULAR	
						DIA. OF SMALL END		SIZE nominal	DIAMETER nominal	kg/m (min.)
						min.-max.	min.-avg.			
UP thru 1.8	UP thru 3.1	25.40	2.50	none	---	125-175	150	150x150	6.40	8.62
2.1 thru 3.4	4.0 thru 6.7	31.75	3.38	1	25.40	125-175	150	150x150	88.90	13.56
3.1 thru 4.9	7.0 thru 9.8	38.10	4.05	2	31.75	175-225	200	200x200	152.40	28.23
5.2 thru 6.0	10.0 thru 12.0	50.80	5.43	2	31.75	225-275	250	250x250	152.40	28.23

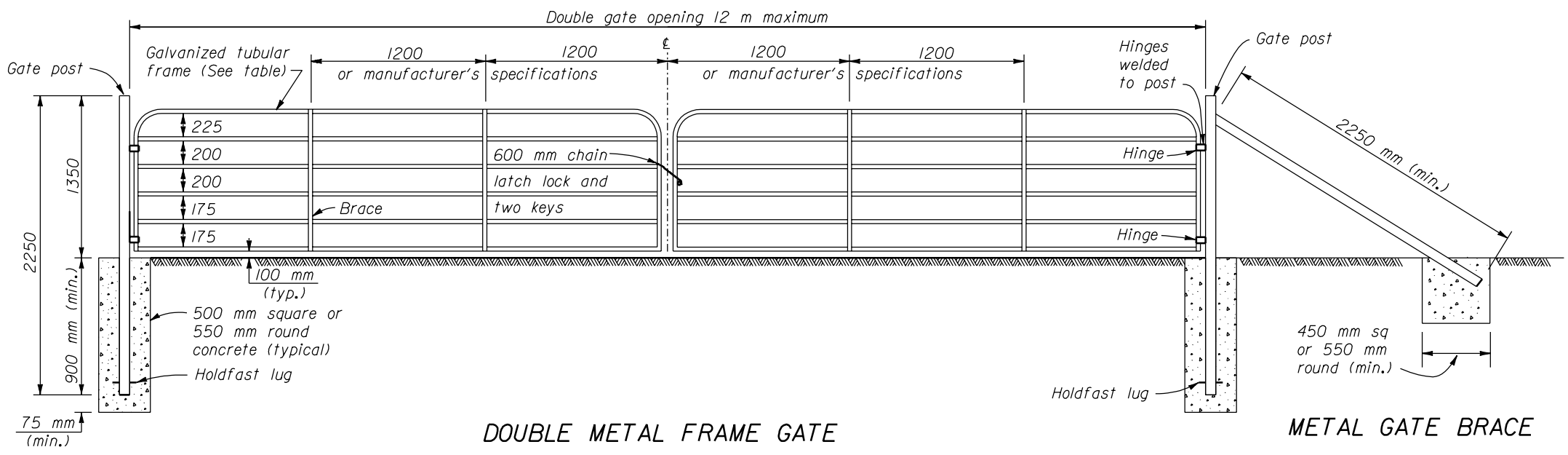

U.S. DEPARTMENT OF TRANSPORTATION
 FEDERAL HIGHWAY ADMINISTRATION
 WESTERN FEDERAL LANDS HIGHWAY DIVISION

METRIC DETAIL

**OREGON
 RIGHT-OF-WAY GATES**

DETAIL APPROVED FOR USE 3/1996
 REVISIONS: 5/2000

DETAIL
WM619-71

13 DEC 2000 f:\standrow\metric\details\wm61971.dgn

NO SCALE

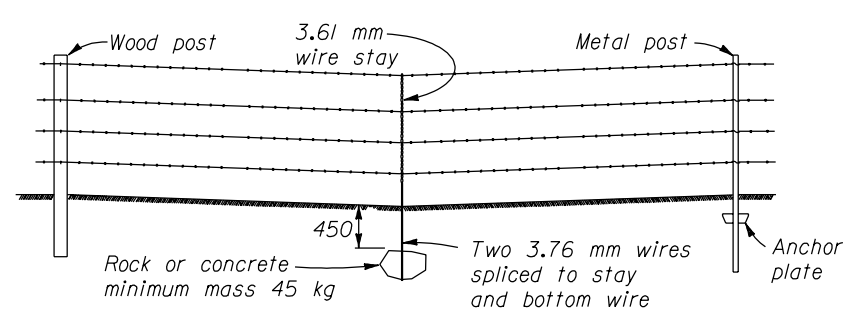

TYPICAL SAG SECTION - TYPE 1 & 2 FENCES

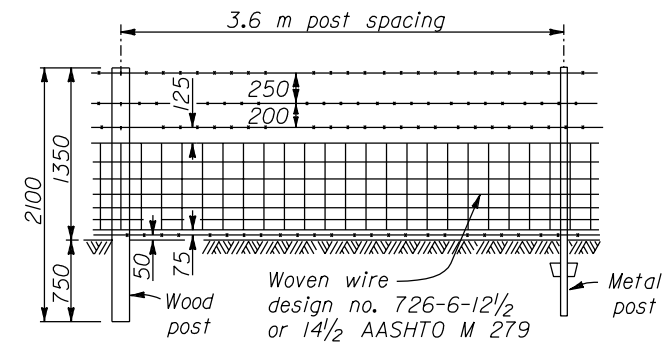

TYPE 1

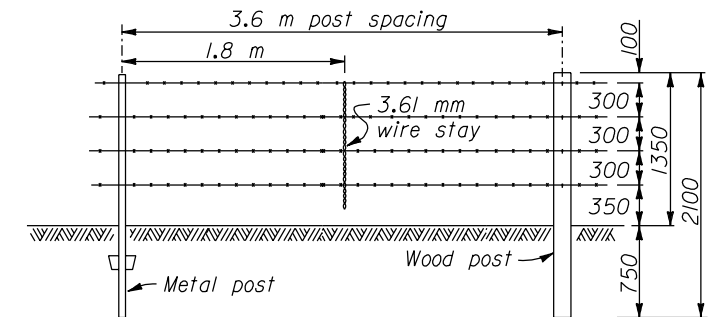

TYPE 2

FENCES

- NOTE:**
- Dimensions not labeled are in millimeters.
 - Furnish either zinc coated (galvanized) or aluminum coated steel barbed wire. Fabricate zinc coated barbed wire from two strands of 2.51 mm steel wire with a Class 3 zinc coating and 2 point or 4 point barbs of 2.03 mm zinc coated wire. Fabricate aluminum coated barbed wire from two strands of 2.51 mm aluminum coated steel wire with 4 point barbs of 2.03 mm aluminum coated or aluminum alloy wire.
 - Furnish either zinc coated (galvanized) or aluminum coated steel wire fence fabric. If zinc coated fabric is furnished, use Grade 60 fabric with a Class 3 coating.
 - Furnish 3.05 mm tie wire or wire clamps for fasteners on metal posts and 3.76 mm by 40 mm long wire staples for wood posts. Galvanize wire stays, tie wire, wire loops, and wire clamps with a Class 1 zinc coating according to ASTM A 641.
 - Furnish either painted or galvanized steel fence posts for tee, channel or U bar shapes. Furnish galvanized steel round pipe or steel angle for posts and braces. Fit round pipe posts with snug-fitting galvanized metal caps. Fabricate steel line posts and angles from Type A steel according to AASHTO M 281. Fabricate steel pipe posts and braces according to AASHTO M 160.
 - Furnish Douglas fir, Western red cedar, Hemlock or Larch for fence posts, brace rails, and wood stays. Treat the posts and brace rails with creosote, pentachlorophenol, ACZA, or CCA, Type I, A, B, or C.

MEMBER	WOOD		STEEL		
	ROUND	SQUARE	SHAPE	kg/m (min.) nominal	SIZE nominal
	Di. of small end (min.)	SIZE nominal			
Line post	75	75x75	Tee, channel or U-bar	1.98	U.S. Comm. Standard
Brace	150	150x150	Round pipe	3.38	approx. 40 mm OD
			Angle	3.63	51x51x6.4 mm
Other posts	150	150x150	Round pipe	5.43	60.3 mm OD
			Angle	6.10	64x64x6.4 mm

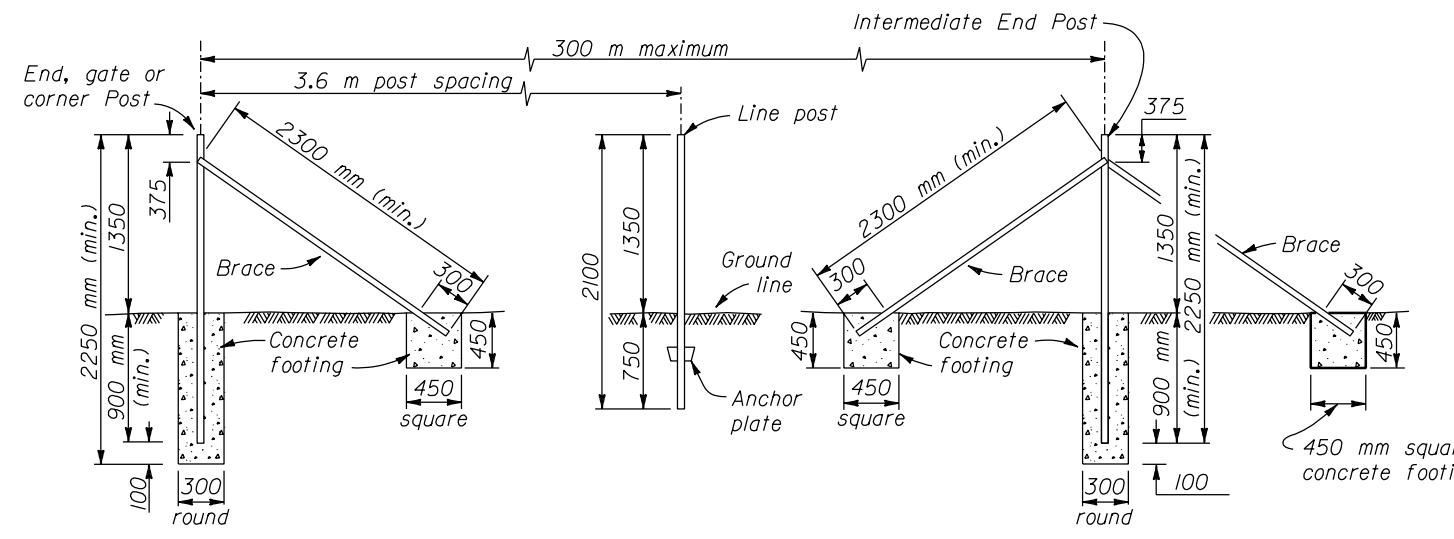

END, GATE OR CORNER BRACE

LINE BRACE

STEEL POSTS

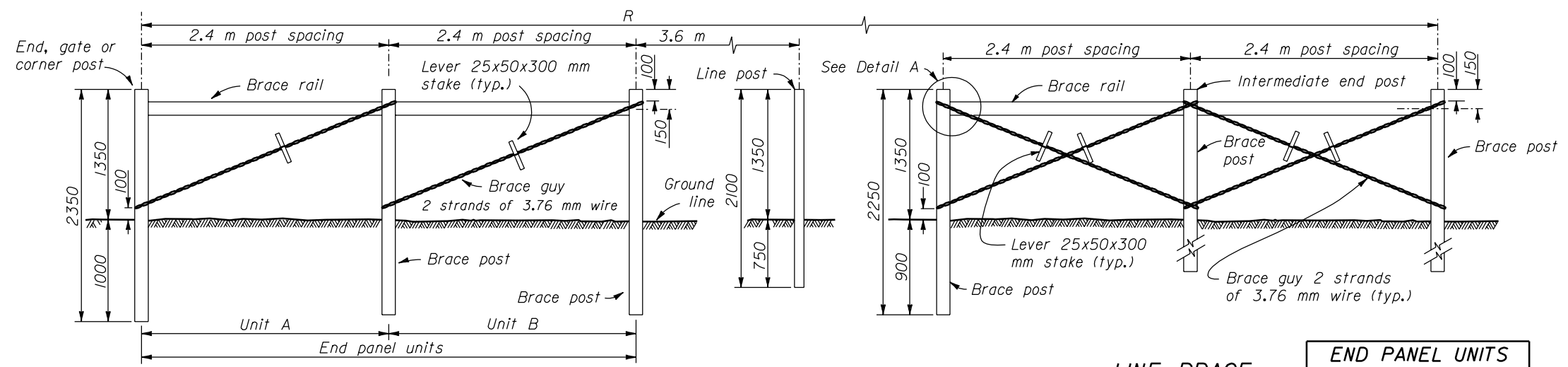

END, GATE OR CORNER BRACE

LINE BRACE

WOOD POSTS

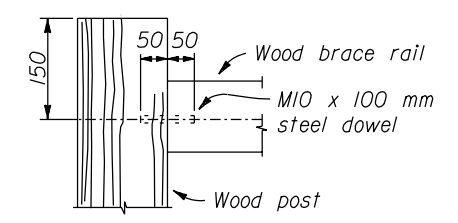

DETAIL A

ALL FENCE TYPES	END PANEL UNITS	
	R	PANELS
	6 or less	None
	6 - 100	A
	Over 100	A & B

NO SCALE

U.S. DEPARTMENT OF TRANSPORTATION
 FEDERAL HIGHWAY ADMINISTRATION
 WESTERN FEDERAL LANDS HIGHWAY DIVISION

METRIC DETAIL

WASHINGTON FENCE

DETAIL APPROVED FOR USE 3/1996

REVISIONS:

DETAIL WM619-80

13 DEC 2000 F:\S:\anDraw\Metric\DETAILS\wm61980.dgn

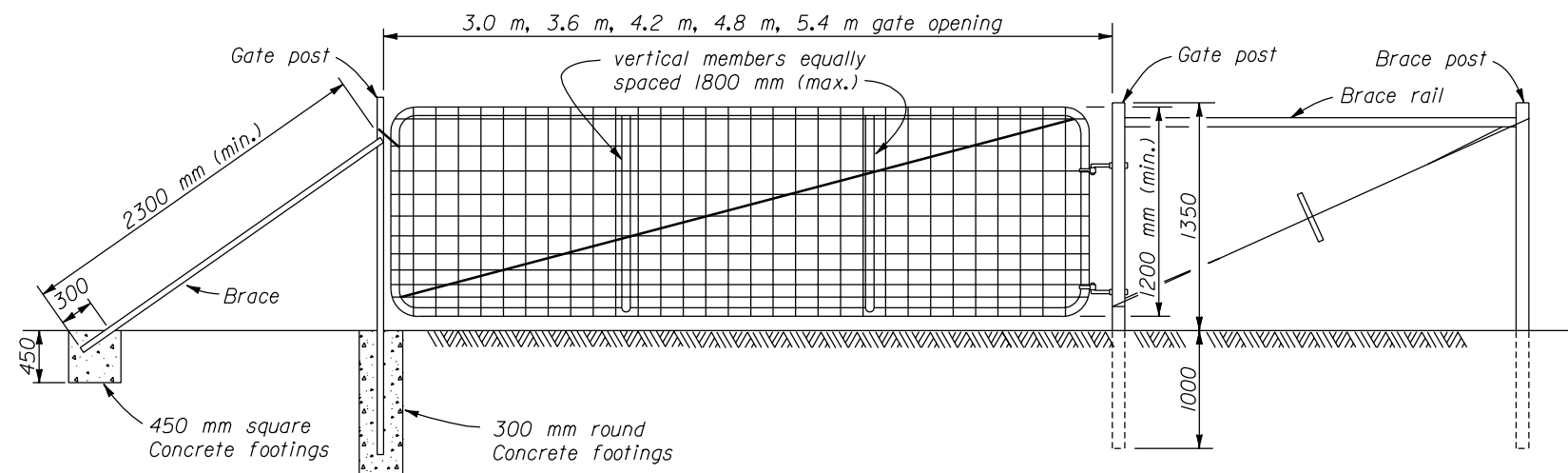

METAL GATE BRACE

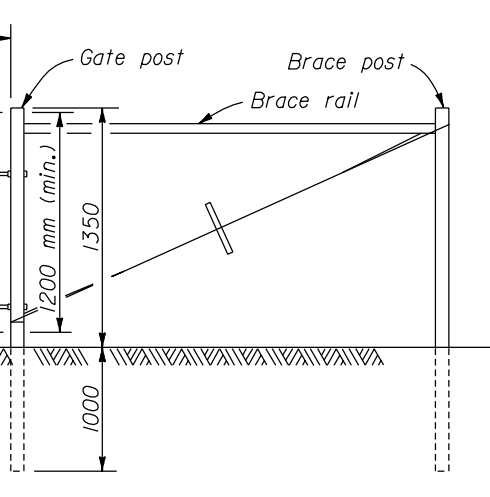

WOOD GATE BRACE

SINGLE METAL ENTRANCE GATE

- NOTE:**
1. Dimensions not labeled are in millimeters.
 2. Manufacture gates of galvanized steel pipe not less than 25 mm nominal diameter (nominal mass 0.76 kg per linear meter) for frame and vertical braces. For each gate, provide two upright braces of the same material as the frame, spaced at 1/3 points in the gate. Place steel wire fence fabric conforming to design no. 1047-6-12 1/2 in AASHTO M 279 on the face of the gate. Equip each gate with adjustable 9.5 mm diameter diagonal truss rods from corner to corner. Provide hinges and 2-way self closing latch of an approved rust proof malleable iron or steel.
 3. Where a single opening requires two gates, provide an approved drop bar and fastener between the gates. Where two metal gates are installed in a single opening both gates will be measured for payment.
 4. Approved alternate gates may be used.

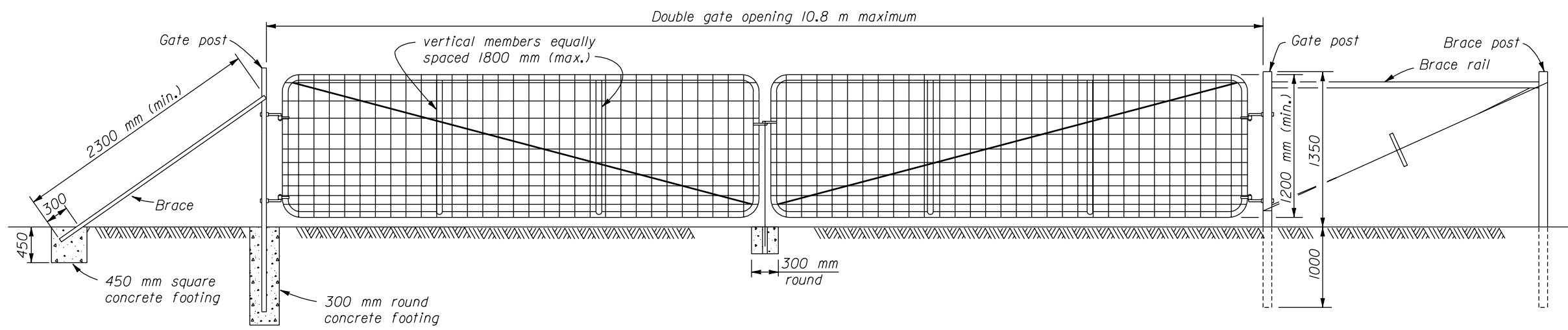

METAL GATE BRACE

WOOD GATE BRACE

DOUBLE METAL ENTRANCE GATE

U.S. DEPARTMENT OF TRANSPORTATION FEDERAL HIGHWAY ADMINISTRATION WESTERN FEDERAL LANDS HIGHWAY DIVISION	
METRIC DETAIL	
WASHINGTON GATE	
DETAIL APPROVED FOR USE 3/1996	DETAIL
REVISED:	WM619-81

NO SCALE