

STEEL PLATE

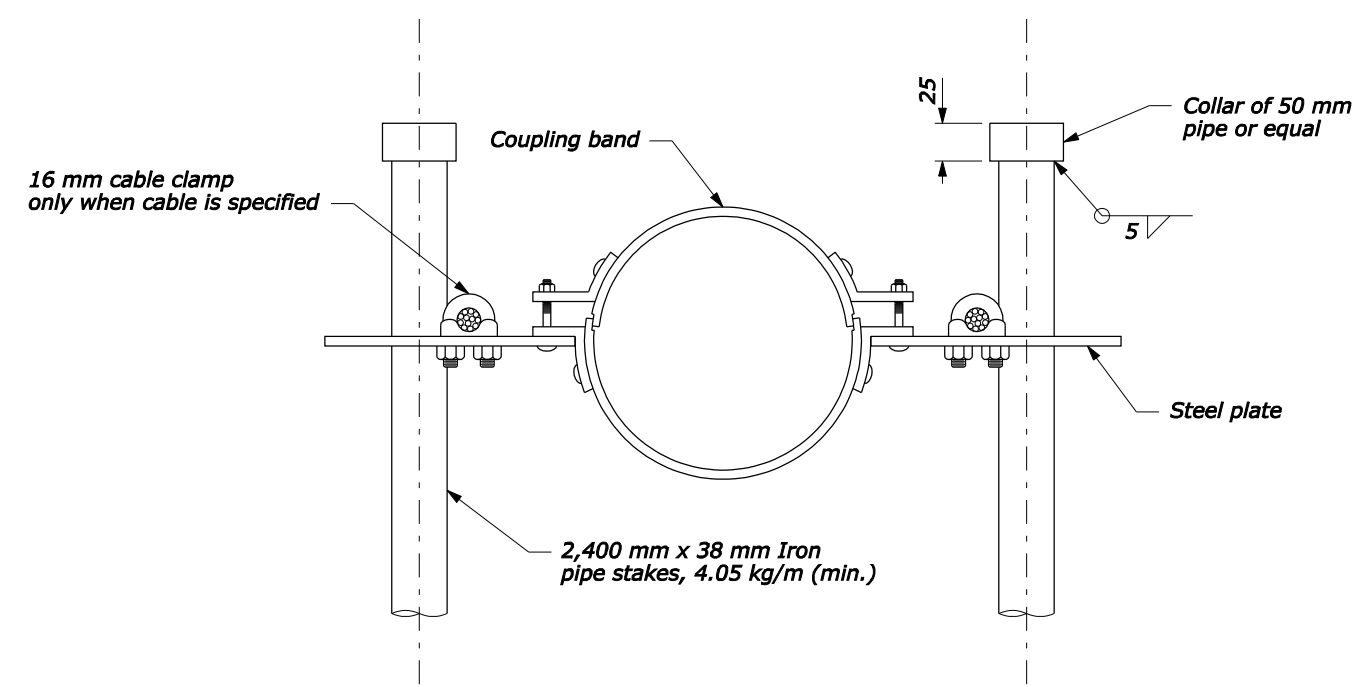

ANCHOR ASSEMBLY

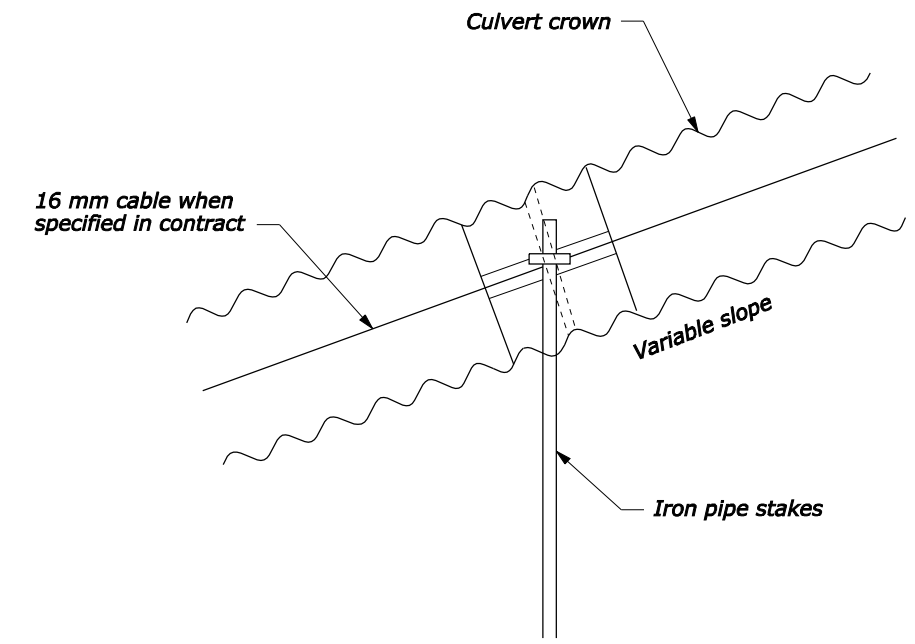

METAL PIPE ASSEMBLY

NOTE:

1. All pipe stakes and hardware to be galvanized after fabrication.
2. Approved alternative pipe anchor assemblies may be used.
3. Place slope anchor assemblies on 6 m max. centers on slopes 20% or greater.
4. Plate material to be ASTM 6 mm galvanize after fabrication.
5. Dimensions without units are millimeters.

NO SCALE

U.S. DEPARTMENT OF TRANSPORTATION FEDERAL HIGHWAY ADMINISTRATION WESTERN FEDERAL LANDS HIGHWAY DIVISION	
METRIC DETAIL	
PIPE ANCHOR ASSEMBLY	
DETAIL APPROVED FOR USE 4/2009	DETAIL
REVISED:	WM606-14

2211428-b-y 1:M 00000000
 fpp://196.145.188.2/scl_plan/wf/w60614.dgn [Metric]