

REINFORCED CONCRETE HEADWALL

PIPE ARCH SIZE	CONCRETE (cuyd)			
	Skew Angle			
	0°	15°	30°	45°
Span x rise				
6'-1" x 4'-7"	3.2	3.4	3.7	4.6
7'-0" x 5'-1"	3.5	3.7	4.1	5.0
8'-2" x 5'-9"	4.0	4.2	4.7	5.7
9'-6" x 6'-5"	4.4	4.6	5.1	6.2
11'-5" x 7'-3"	5.0	5.2	5.8	7.1
12'-10" x 8'-4"	5.8	6.0	6.7	8.2
13'-11" x 8'-7"	6.2	6.4	7.1	8.7
15'-4" x 10'-4"	6.6	6.8	7.6	9.3
16'-3" x 10'-10"	7.3	7.5	8.3	9.5

- NOTE:**
- CONCRETE: Chamfer all exposed edges $\frac{3}{4}$ inch.
 - REINFORCING STEEL: Grade 60 (ASTM A615 or A996) deformed billet steel bars conforming to AASHTO M 31. The minimum concrete cover to the face of any bar is 2 inches unless otherwise shown.
 - HEADWALL TYPE: Use Type A Step Bevel headwalls for round pipe unless otherwise specified in the special contract requirements.
 - STEP BEVEL: The variable dimension indicated for the height or step conform to manufacturer's recommendations unless otherwise specified in the special contract requirements.
 - CUTOFF WALLS: The minimum depth shown may be reduced in solid rock, provided wall is keyed into the rock at least 12".
 - ANCHOR BOLTS: Conform to ASTM A307-04. Galvanize in accordance with ASTM A153.
 - BEDDING: Construct a firm and uniform foundation before placing the bedding. Use clean $\frac{3}{8}$ inch sandy material for bedding unless otherwise specified in the special contract requirements.
 - ESTIMATED QUANTITIES: The concrete quantities are based on a 3 foot cut-off wall and 1:1.5 fill slopes for each of the skew angles. Interpolate concrete quantities for headwalls not shown. Reinforcing steel is estimated at 68 lb/cuyd of concrete excluding the weight of the anchor bolts.

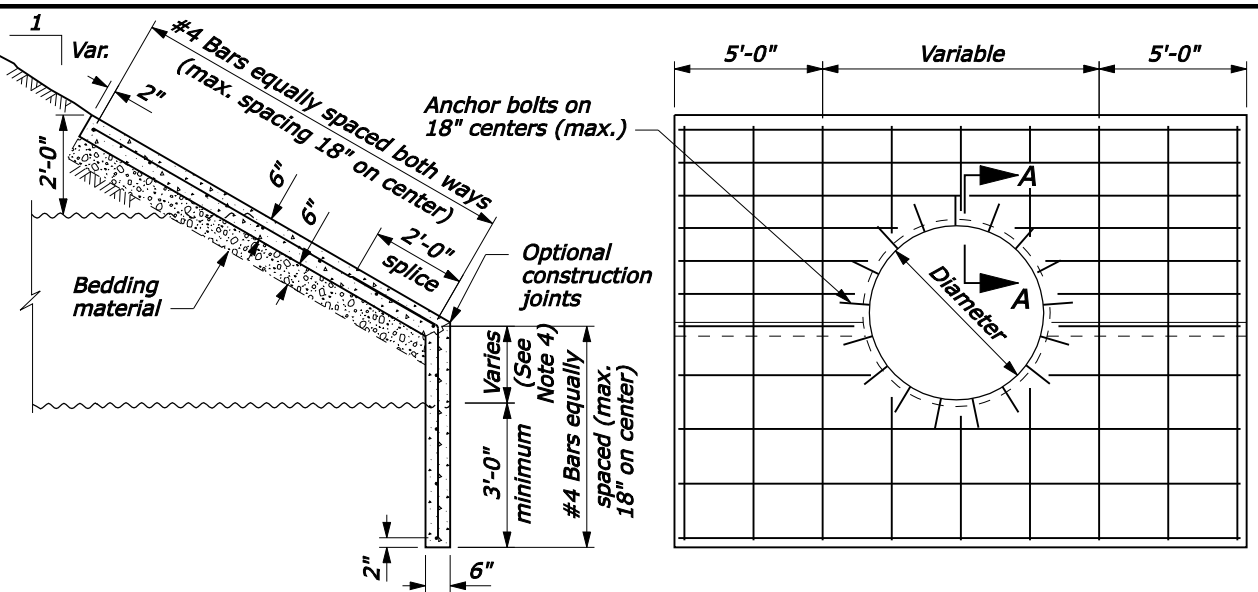

TYPE A STEP BEVEL FOR ROUND PIPE

REINFORCED CONCRETE HEADWALL

PIPE SIZE	CONCRETE (cuyd)							
	TYPE A STEP BEVEL				TYPE B FULL BEVEL			
	Skew Angle				Skew Angle			
Diameter	0°	15°	30°	45°	0°	15°	30°	45°
48"	3.2	3.2	3.3	3.5	2.7	3.0	3.4	3.4
60"	3.6	3.7	3.8	4.0	3.7	3.7	3.8	4.0
72"	4.1	4.1	4.2	4.5	4.2	4.3	4.4	4.6
84"	4.5	4.6	4.7	5.0	4.8	4.8	5.0	5.3
96"	5.1	5.2	5.3	5.7	5.3	5.4	5.6	5.9
108"	5.6	5.7	5.9	6.3	5.9	6.0	6.2	6.7
120"	6.0	6.1	6.3	6.8	6.5	6.6	6.8	7.3
132"	6.9	7.0	7.3	7.9	7.1	7.2	7.5	8.0
144"	7.4	7.5	7.8	8.5	7.7	7.9	8.1	8.8
156"	7.9	8.0	8.3	9.1	8.4	8.5	8.8	9.5
168"	8.6	8.8	9.2	10.0	9.0	9.2	9.5	10.4
180"	8.9	9.1	9.4	10.3	9.7	9.8	10.2	11.1

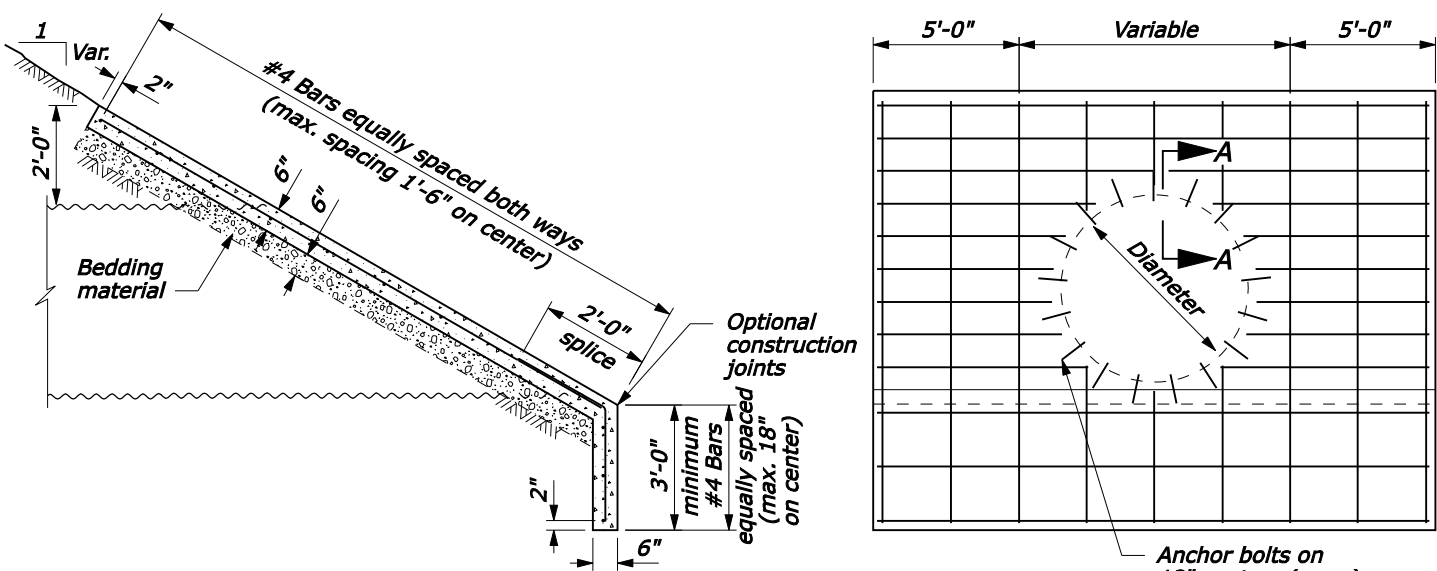

TYPE B FULL BEVEL FOR ROUND PIPE

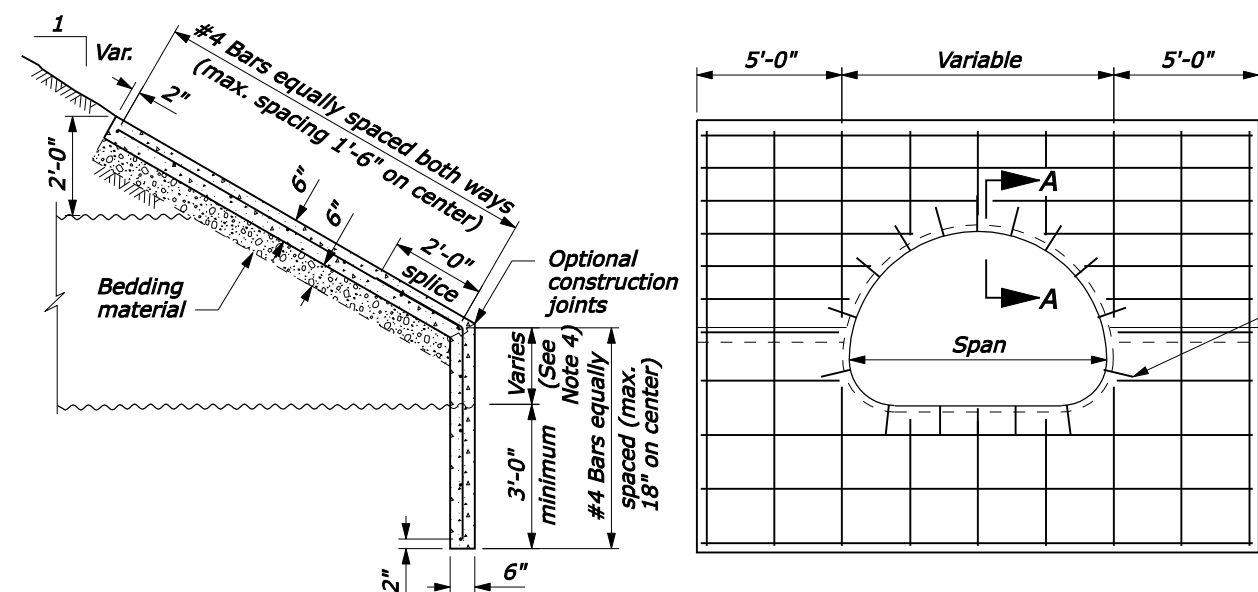

STEP BEVEL FOR PIPE ARCH CULVERT

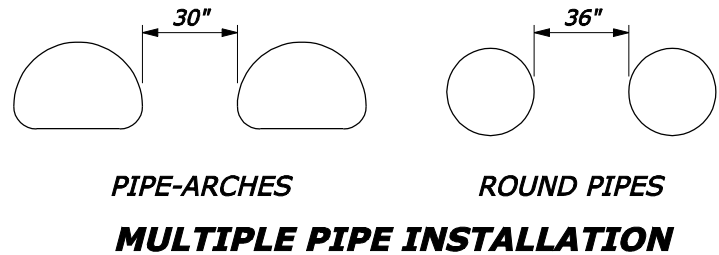
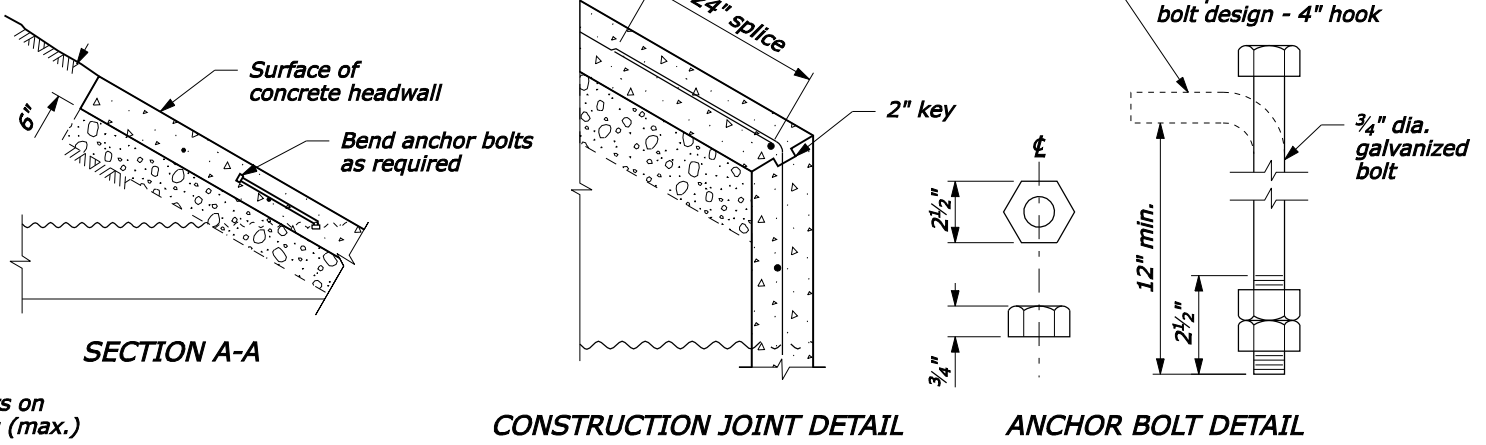

U.S. DEPARTMENT OF TRANSPORTATION
FEDERAL HIGHWAY ADMINISTRATION
WESTERN FEDERAL LANDS HIGHWAY DIVISION

U.S. CUSTOMARY DETAIL

REINFORCED CONCRETE HEADWALL

DETAIL APPROVED FOR USE 11/2006

REVISOR: _____

DETAIL W601-10

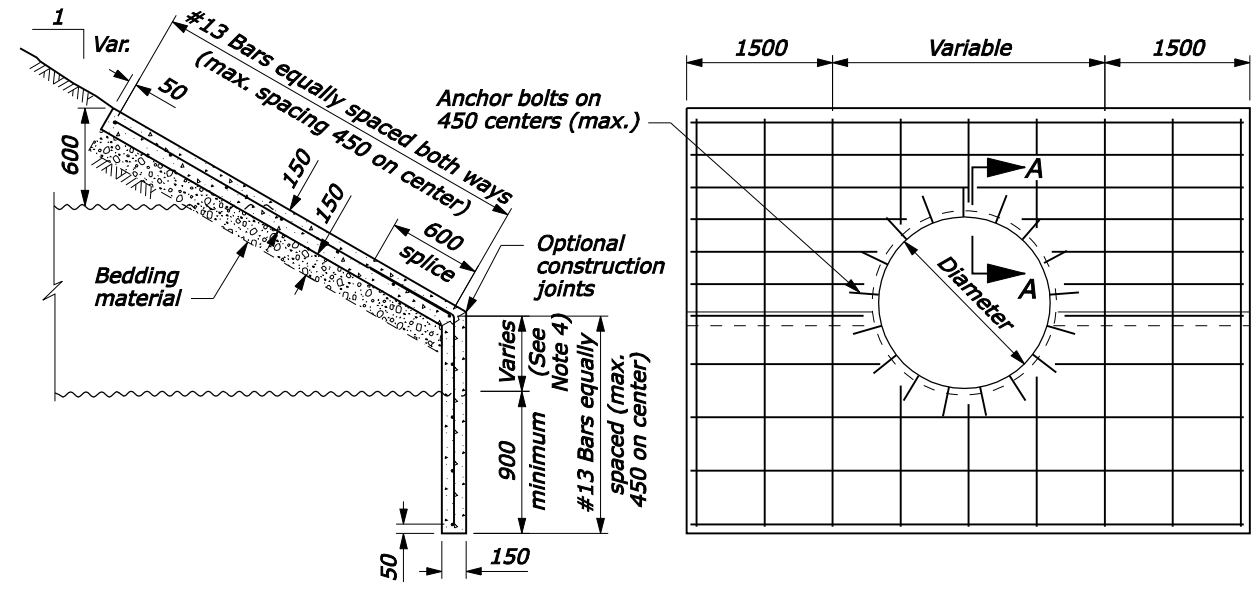

TYPE A STEP BEVEL FOR ROUND PIPE

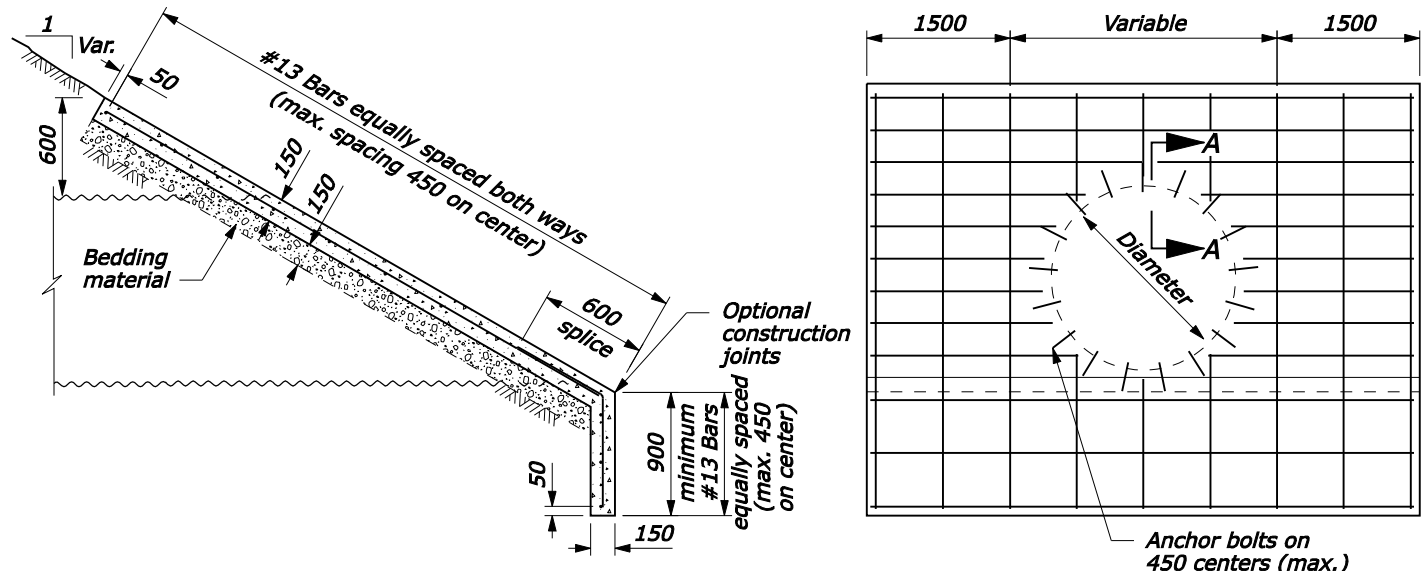

TYPE B FULL BEVEL FOR ROUND PIPE

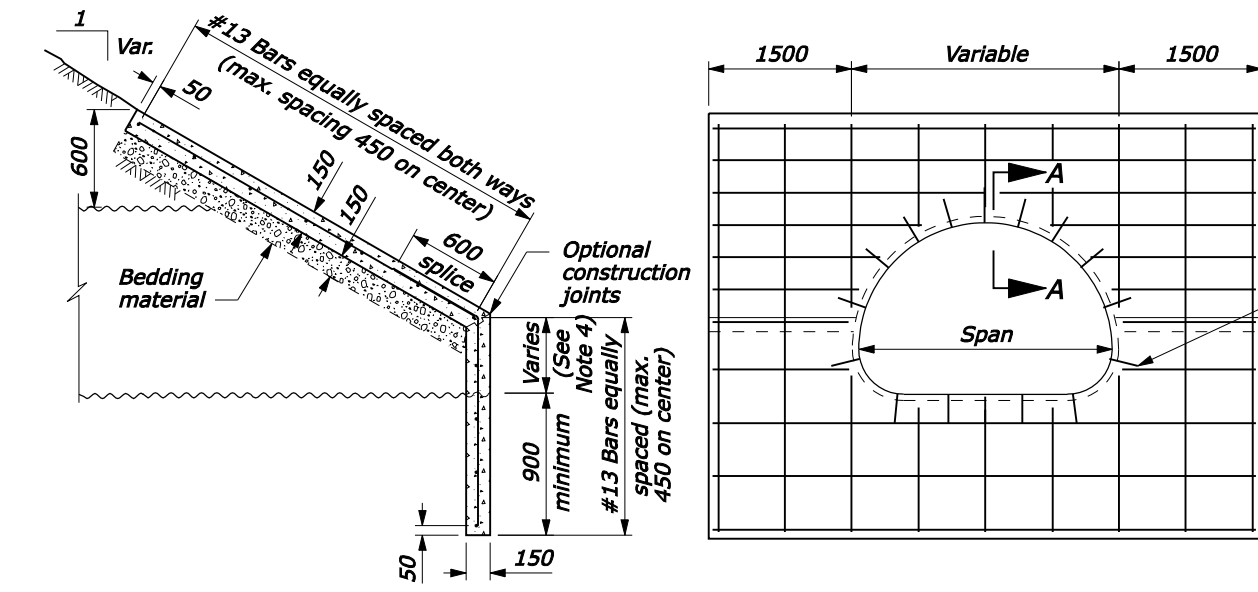

STEP BEVEL FOR PIPE ARCH CULVERT

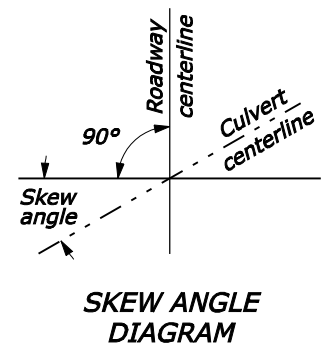

SKIEW ANGLE DIAGRAM

REINFORCED CONCRETE HEADWALL				
STEP BEVEL PIPE ARCH CULVERT				
PIPE ARCH SIZE	CONCRETE (m3)			
	Skew Angle			
Span x rise	0°	15°	30°	45°
1855 x 1400	2.4	2.6	2.8	3.5
2060 x 1500	2.7	2.8	3.1	3.8
2415 x 1700	3.1	3.2	3.3	4.4
2845 x 1905	3.4	3.5	3.9	4.7
3480 x 2210	3.8	4.0	4.4	5.4
3910 x 2540	4.5	4.6	5.1	6.3
4240 x 2615	4.7	4.9	5.4	6.7
4675 x 3150	5.0	5.2	5.8	7.1
4955 x 3300	5.6	5.7	6.3	7.3

REINFORCED CONCRETE HEADWALL									
ROUND PIPE CULVERT									
PIPE SIZE	CONCRETE (m3)								
	Diameter	TYPE A STEP BEVEL				TYPE B FULL BEVEL			
		Skew Angle				Skew Angle			
	0°	15°	30°	45°	0°	15°	30°	45°	
1200	2.5	2.5	2.6	2.8	2.2	2.4	2.7	2.7	
1500	2.8	2.8	2.9	3.1	2.8	2.8	2.9	3.1	
1800	3.1	3.1	3.2	3.4	3.2	3.3	3.4	3.5	
2100	3.4	3.5	3.6	3.8	3.7	3.7	3.8	4.1	
2400	3.9	4.0	4.1	4.4	4.1	4.1	4.3	4.5	
2700	4.3	4.4	4.5	4.8	4.5	4.6	4.7	5.1	
3000	4.6	4.7	4.8	5.2	5.0	5.0	5.2	5.6	
3300	5.3	5.4	5.6	6.0	5.4	5.5	5.7	6.1	
3600	5.7	5.7	6.0	6.5	5.9	6.0	6.2	6.7	
3900	6.0	6.1	6.3	7.0	6.4	6.5	6.7	7.3	
4200	6.6	6.7	7.0	7.6	6.9	7.0	7.3	8.0	
4500	6.8	7.0	7.2	7.8	7.4	7.5	7.8	8.5	

- NOTE:**
1. CONCRETE: Chamfer all exposed edges 20 mm.
 2. REINFORCING STEEL: Grade 420 (ASTM A615M or A996M) deformed billet steel bars conforming to AASHTO M 31. The minimum concrete cover to the face of any bar is 50 mm unless otherwise shown.
 3. HEADWALL TYPE: Use Type A Step Bevel headwalls for round pipe unless otherwise specified in the special contract requirements.
 4. STEP BEVEL: The variable dimension indicated for the height or step conform to manufacturer's recommendations unless otherwise specified in the special contract requirements.
 5. CUTOFF WALLS: The minimum depth shown may be reduced in solid rock, provided wall is keyed into the rock at least 300 mm.
 6. ANCHOR BOLTS: Conform to ASTM A307-04. Galvanize in accordance with ASTM A153M.
 7. BEDDING: Construct a firm and uniform foundation before placing the bedding. Use clean 10 mm sandy material for bedding unless otherwise specified in the special contract requirements.
 8. ESTIMATED QUANTITIES: The concrete quantities are based on a 900 mm cut-off wall and 1:1.5 fill slopes for each of the skew angles. Interpolate concrete quantities for headwalls not shown. Reinforcing steel is estimated at 32 kg/m3 of concrete excluding the weight of the anchor bolts.
 9. Furnish hardware in the metric sizes shown. Equivalent US Customary sizes may be used when metric sizes are not available.
 10. Dimensions without units are millimeters.

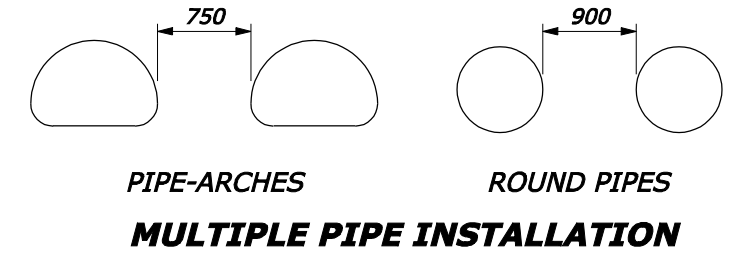
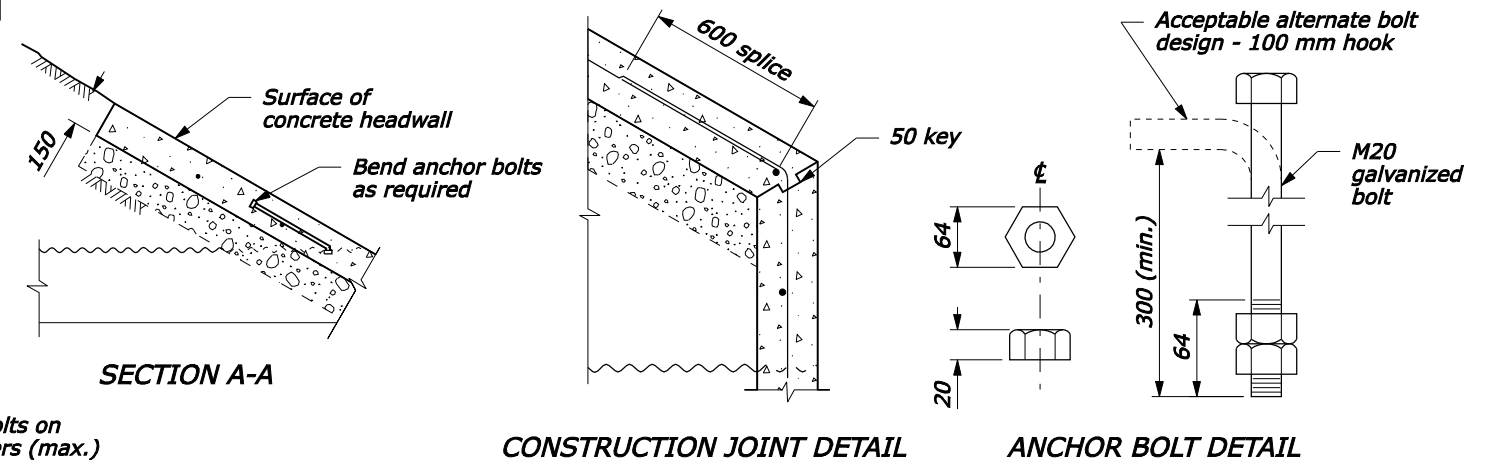

NO SCALE

U.S. DEPARTMENT OF TRANSPORTATION
 FEDERAL HIGHWAY ADMINISTRATION
 WESTERN FEDERAL LANDS HIGHWAY DIVISION

METRIC DETAIL

REINFORCED CONCRETE HEADWALL

DETAIL APPROVED FOR USE 11/2006
 REVISIONS: _____

DETAIL
 WM601-10

20-Nov-2006 01:31 PM
 F:\StandDraw\Western\w60110.dgn [Metric]

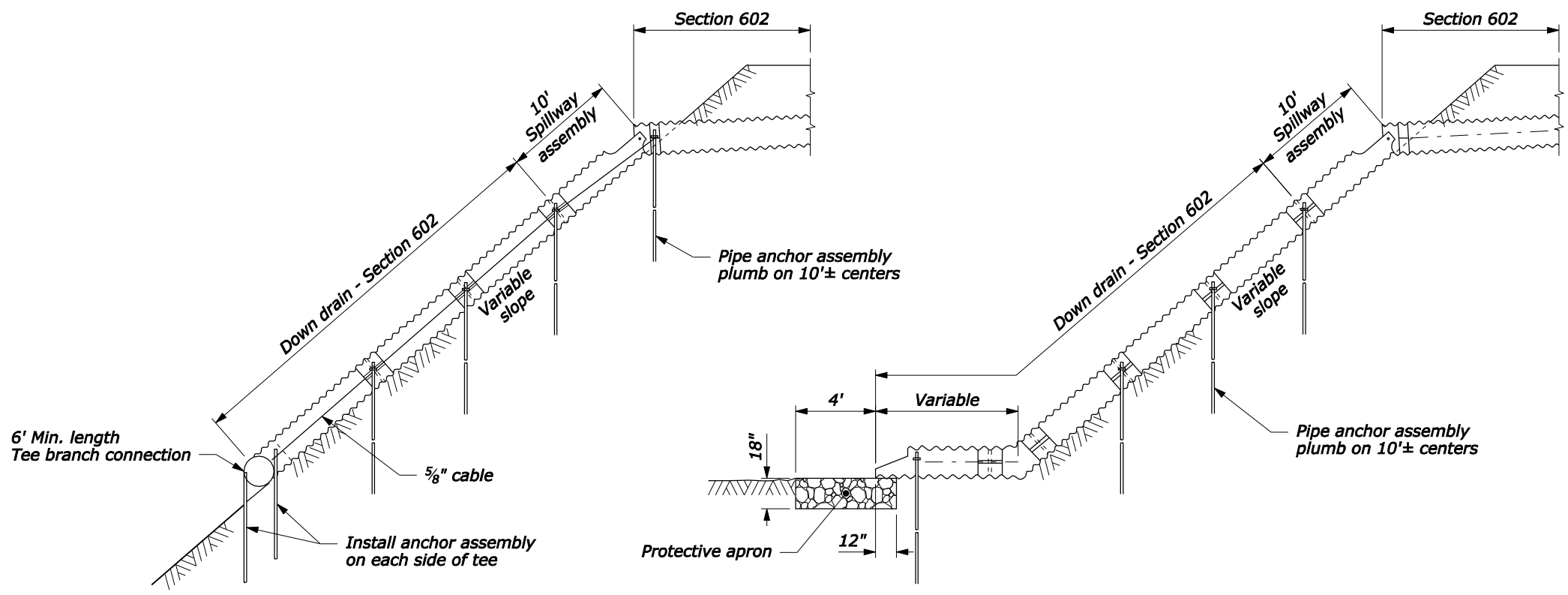

ELEVATION

SPILLWAY ASSEMBLY WITH DOWN DRAIN OUTLET ON NON-ERODIBLE MATERIAL

ELEVATION

SPILLWAY ASSEMBLY WITH DOWN DRAIN OUTLET ON ERODIBLE MATERIAL

NOTE:

1. Fabricate spillway assembly from annular corrugated pipe, or from helically corrugated pipe with factory annular or reformed ends. Use 0.064 inch galvanized steel or 0.060 inch aluminum.
2. Make all banded connections water tight by placing $\frac{3}{16}$ inch bead of approved caulking under each half of the band before tightening.
3. Payment for Tee Branch connection under Section 602 is included in the linear measurement for culvert pipe for the applicable sizes. Measure Tee Branch connections along the top of the Tee.
4. Place class 2 riprap conforming to Section 251 for protective apron.
5. Approved alternate designs may be used.
6. See Detail W606-14 for Pipe Anchor Assembly Detail.

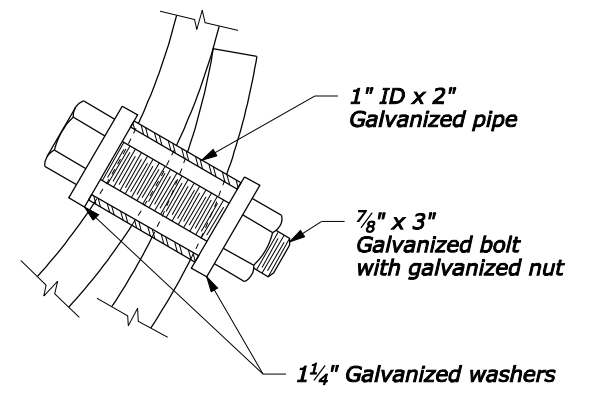

BOLT DETAIL

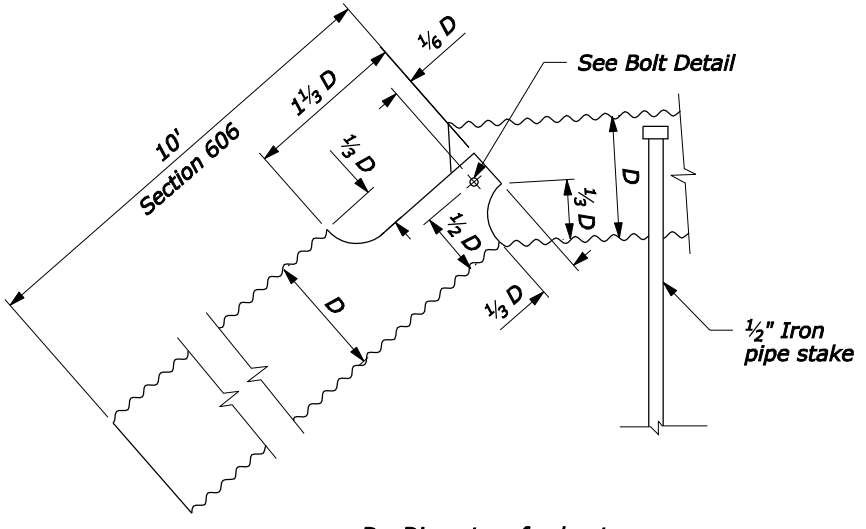

D= Diameter of culvert

SPILLWAY ASSEMBLY

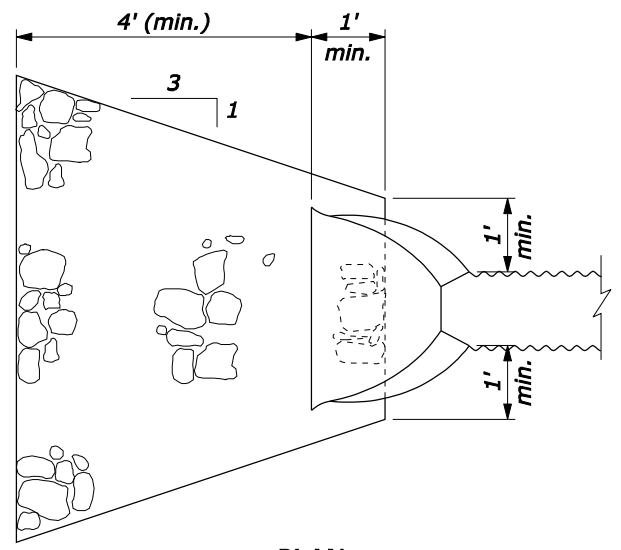

PLAN

PROTECTIVE APRON

NO SCALE

U.S. DEPARTMENT OF TRANSPORTATION FEDERAL HIGHWAY ADMINISTRATION WESTERN FEDERAL LANDS HIGHWAY DIVISION	
U.S. CUSTOMARY DETAIL	
SPILLWAY ASSEMBLY WITH DOWN DRAIN	
DETAIL APPROVED FOR USE 4/2009	DETAIL
REVISED:	W606-10

P:\198.145.186.2\std.pln\w60610.dgn [US Customary] 2211428-b-Y I:M 00000000

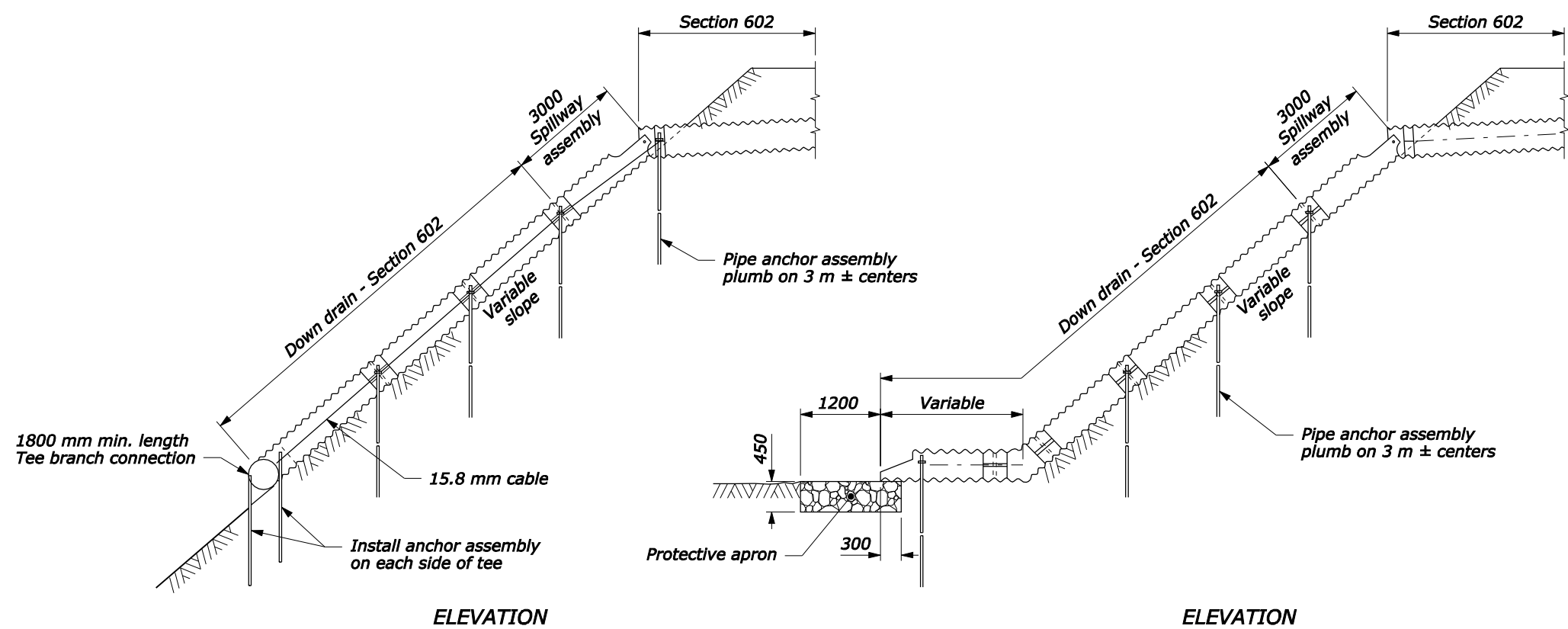

**SPILLWAY ASSEMBLY WITH DOWN DRAIN
OUTLET ON NON-ERODIBLE MATERIAL**

**SPILLWAY ASSEMBLY WITH DOWN DRAIN
OUTLET ON ERODIBLE MATERIAL**

NOTE:

1. Fabricate spillway assembly from annular corrugated pipe, or from helically corrugated pipe with factory annular or reformed ends. Use 1.6 mm galvanized steel or 1.5 mm aluminum.
2. Make all banded connections water tight by placing 5 mm bead of approved caulking under each half of the band before tightening.
3. Payment for Tee Branch connection under Section 602 is included in the linear measurement for culvert pipe for the applicable sizes. Measure Tee Branch connections along the top of the Tee.
4. Place class 2 riprap conforming to Section 251 for protective apron.
5. Approved alternate designs may be used.
6. See Detail WM606-14 for Pipe Anchor Assembly Detail.
7. Furnish hardware in the metric sizes shown. Equivalent US Customary sizes may be used when metric sizes are unavailable.
8. Dimensions without units are millimeters.

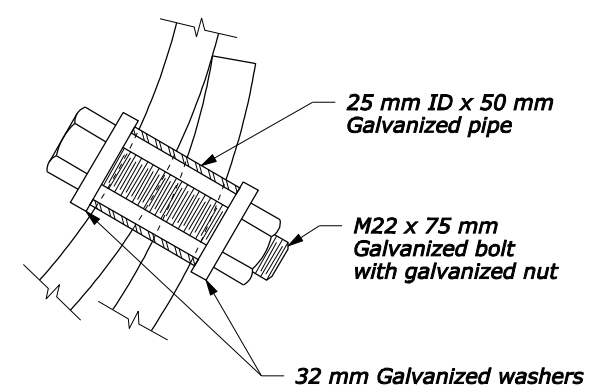

BOLT DETAIL

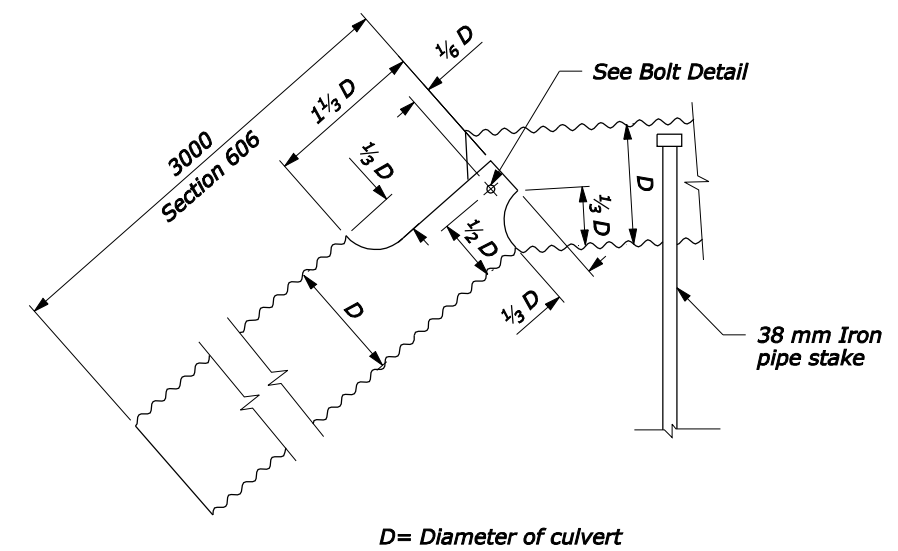

SPILLWAY ASSEMBLY

D= Diameter of culvert

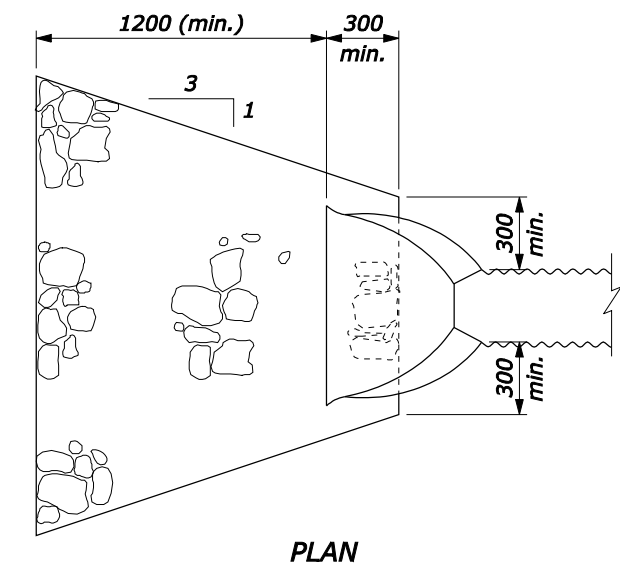

PROTECTIVE APRON

U.S. DEPARTMENT OF TRANSPORTATION FEDERAL HIGHWAY ADMINISTRATION WESTERN FEDERAL LANDS HIGHWAY DIVISION	
METRIC DETAIL	
SPILLWAY ASSEMBLY WITH DOWN DRAIN	
DETAIL APPROVED FOR USE 3/1996	DETAIL
REVISED: 4/2009	WM606-10

NO SCALE

2211428-B-Y 1:M 00000000
ftp://196.145.188.2/scl_plan/wf/w60610.dgn [Metric]

NOTE:

1. All pipe stakes and hardware to be galvanized after fabrication.
2. Approved alternative pipe anchor assemblies may be used.
3. Place slope anchor assemblies on 20' max. centers on slopes 20% or greater.
4. Plate material to be ASTM 1/4" galvanized after fabrication.

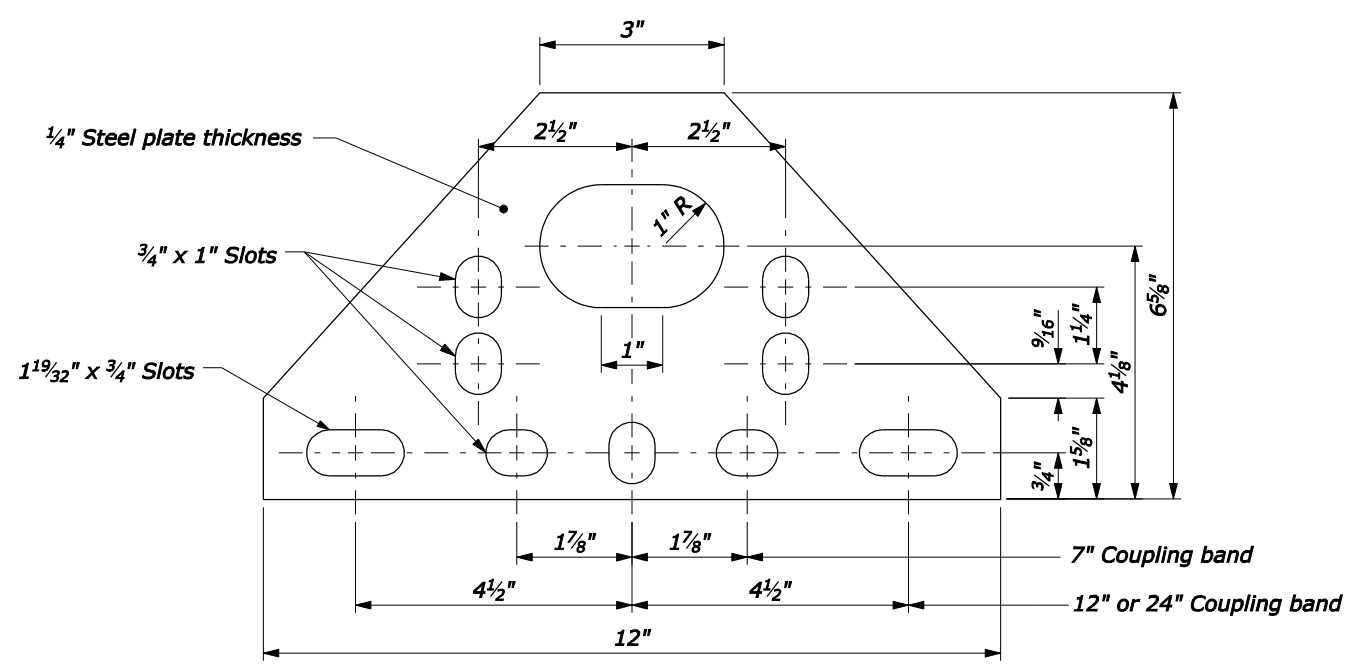

Measure length of coupling band parallel to the centerline of the pipe

STEEL PLATE

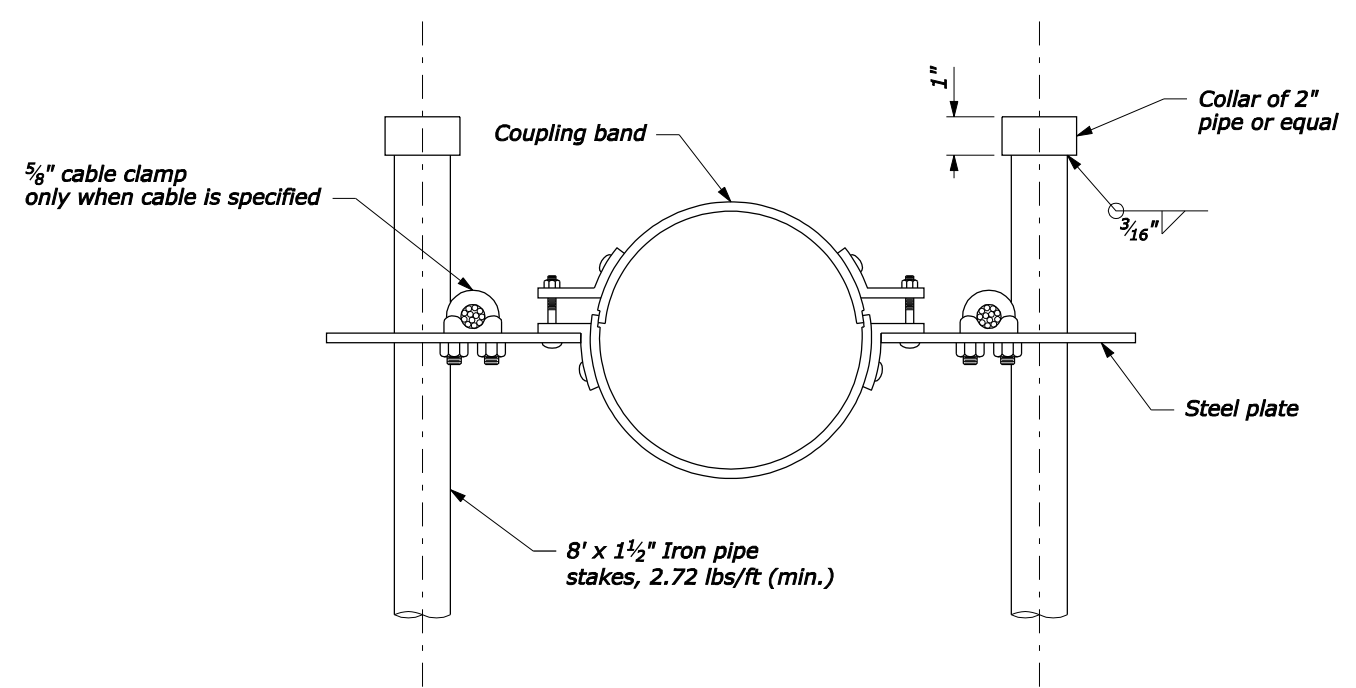

ANCHOR ASSEMBLY

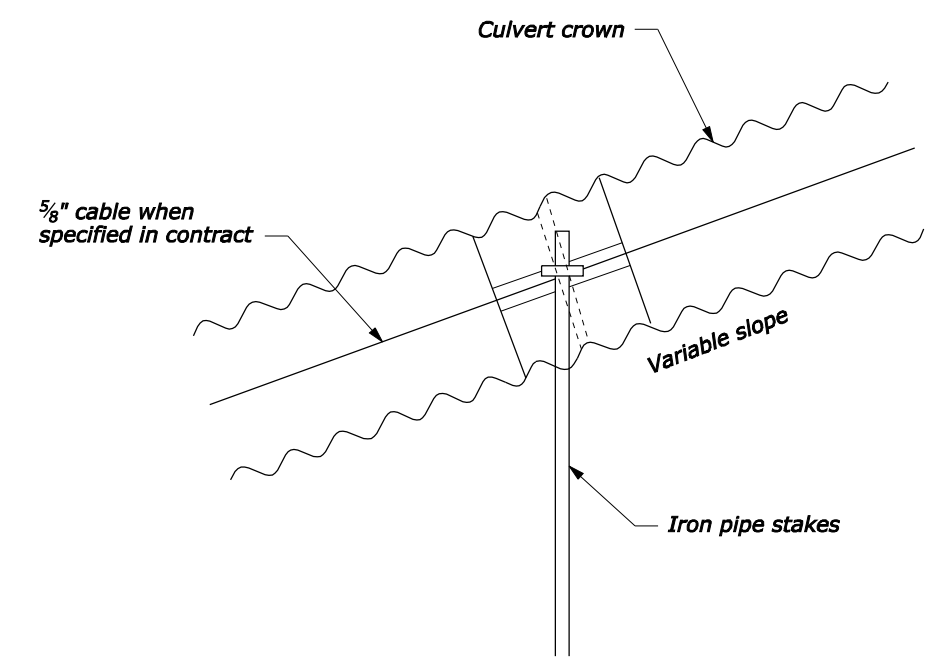

METAL PIPE ASSEMBLY

P:\198.145.186.2\std.pln\w60614.dgn [US Customary] 2211428-b-Y I:M 00000000

NO SCALE

U.S. DEPARTMENT OF TRANSPORTATION FEDERAL HIGHWAY ADMINISTRATION WESTERN FEDERAL LANDS HIGHWAY DIVISION	
U.S. CUSTOMARY DETAIL	
PIPE ANCHOR ASSEMBLY	
DETAIL APPROVED FOR USE 4/2009	DETAIL
REVISED:	W606-14

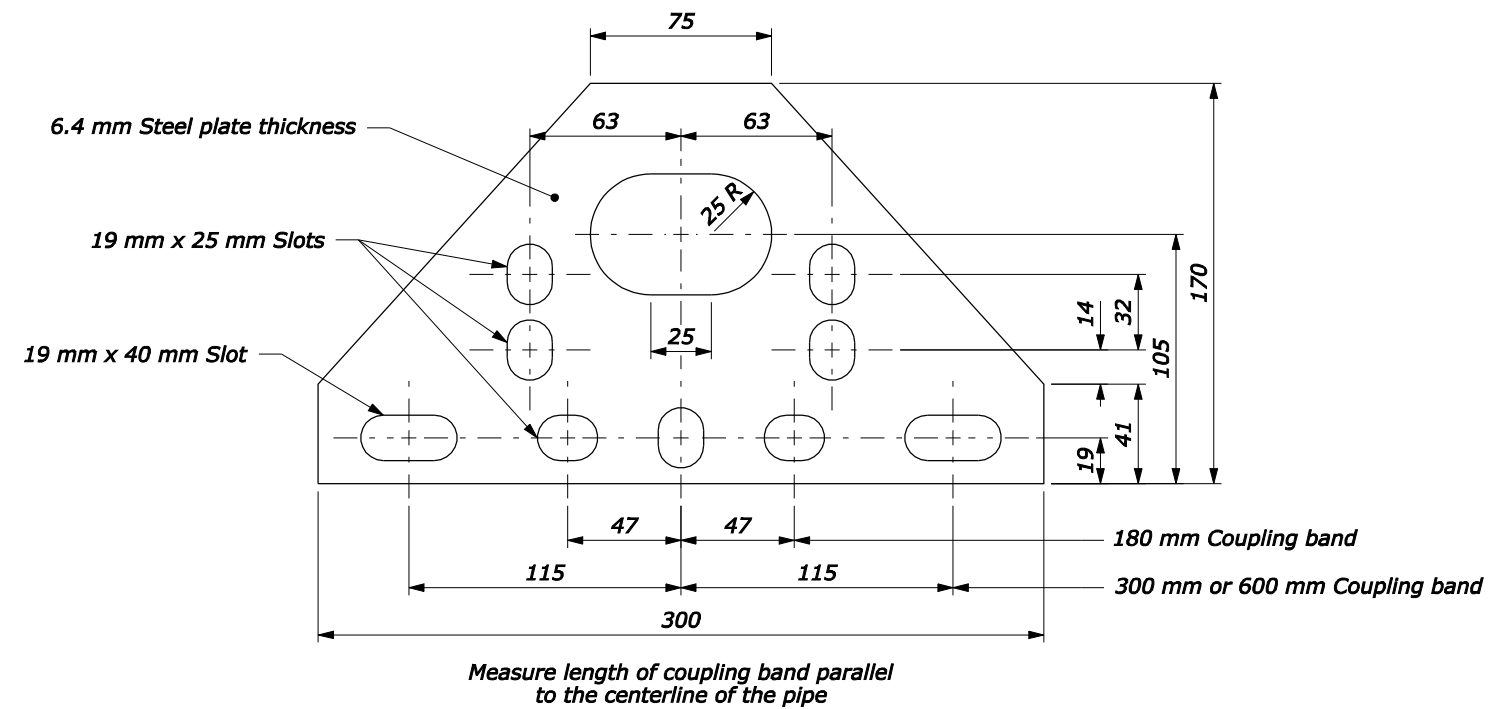

STEEL PLATE

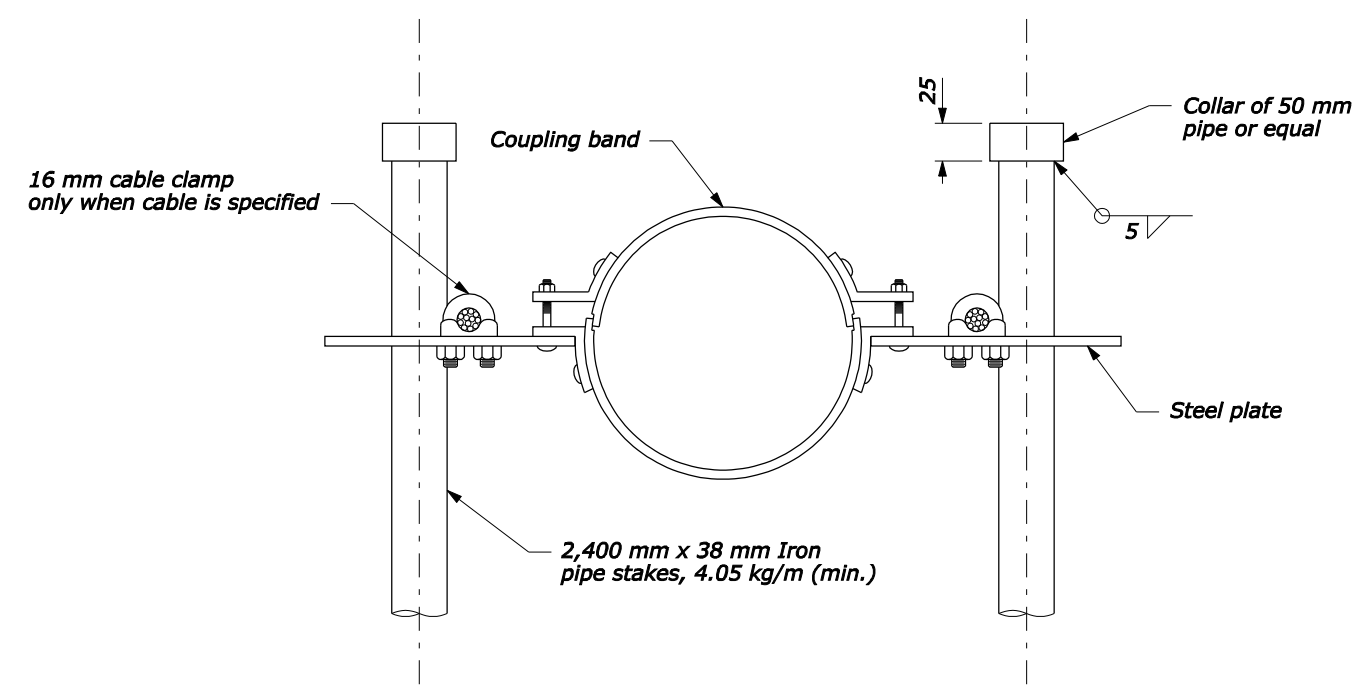

ANCHOR ASSEMBLY

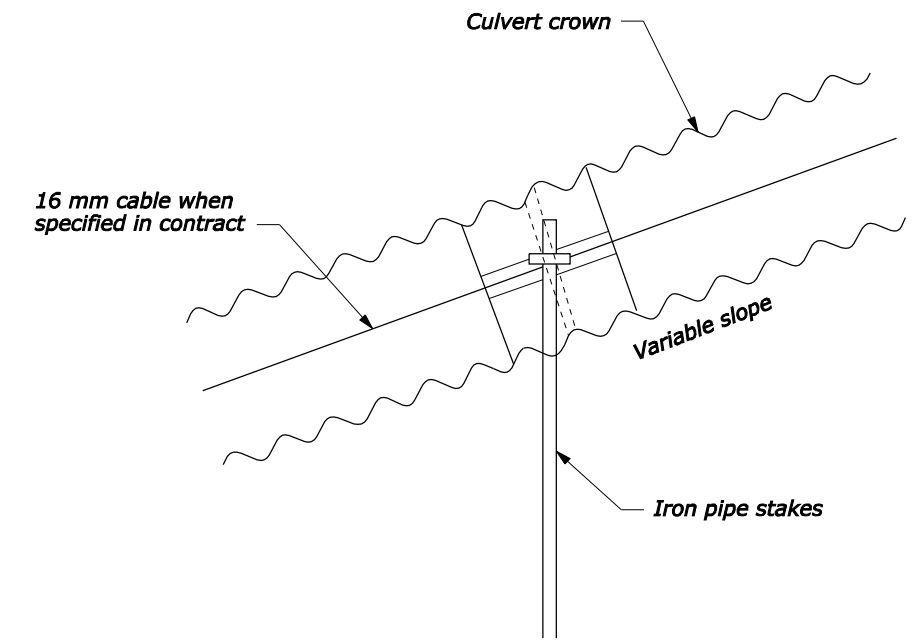

METAL PIPE ASSEMBLY

NOTE:

1. All pipe stakes and hardware to be galvanized after fabrication.
2. Approved alternative pipe anchor assemblies may be used.
3. Place slope anchor assemblies on 6 m max. centers on slopes 20% or greater.
4. Plate material to be ASTM 6 mm galvanize after fabrication.
5. Dimensions without units are millimeters.

NO SCALE

U.S. DEPARTMENT OF TRANSPORTATION FEDERAL HIGHWAY ADMINISTRATION WESTERN FEDERAL LANDS HIGHWAY DIVISION	
METRIC DETAIL	
PIPE ANCHOR ASSEMBLY	
DETAIL APPROVED FOR USE 4/2009	DETAIL
REVISED:	WM606-14

2211428-b-y 1:M 00000000
 fpp://196.145.188.2/scl_plan/wf/w60614.dgn [Metric]

NOTE:

1. Dimensions not labeled are in millimeters.
2. Fabricate spillway assembly from annular corrugated pipe, or from helically corrugated pipe with factory annular or reformed ends. Use 1.6 mm galvanized steel or 1.5 mm aluminum.
3. Make all coupling band connections water tight by placing 5 mm bead of approved caulking under each half of the band before tightening.
4. Place Class 2 riprap conforming to Section 251 for protective apron.
5. Galvanize all items of anchor assembly after fabrication.
6. Furnish hardware in the metric sizes shown. Equivalent imperial sizes may be used when metric sizes all not available.
7. Approved alternate designs may be used.

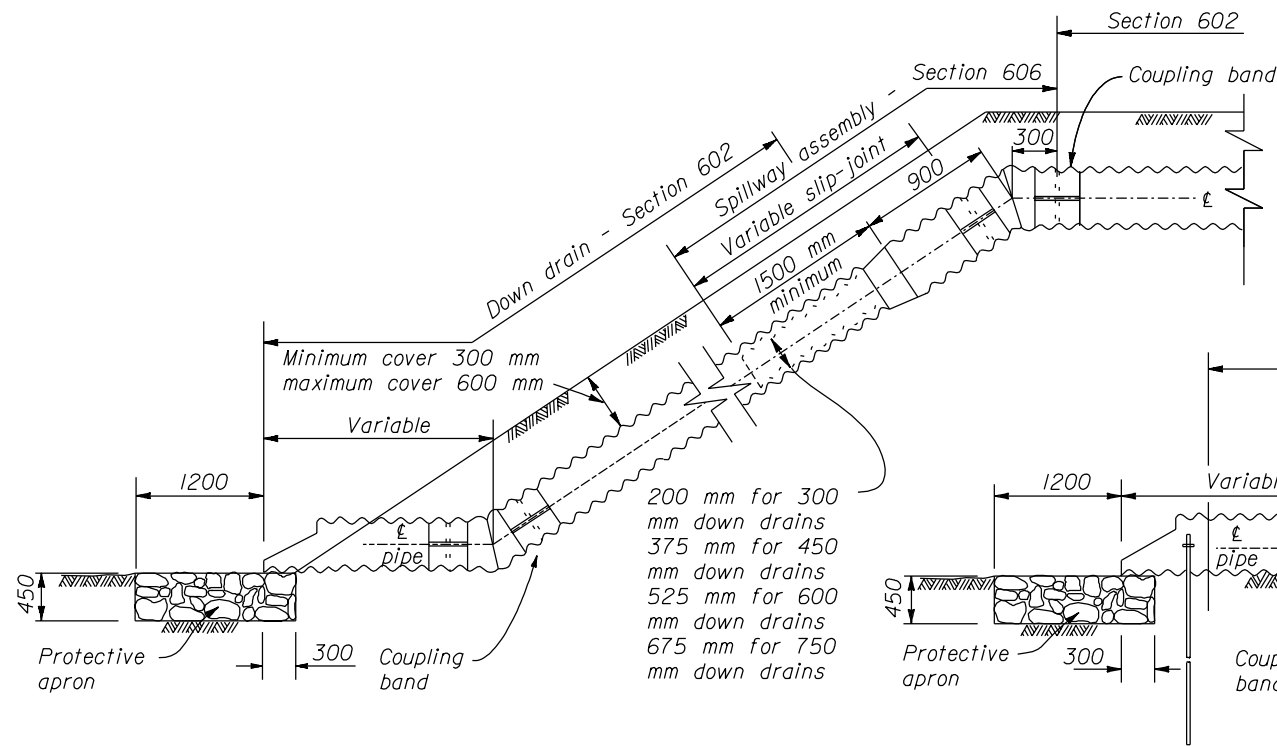

ELEVATION

SPILLWAY ASSEMBLY WITH BURIED DOWN DRAIN

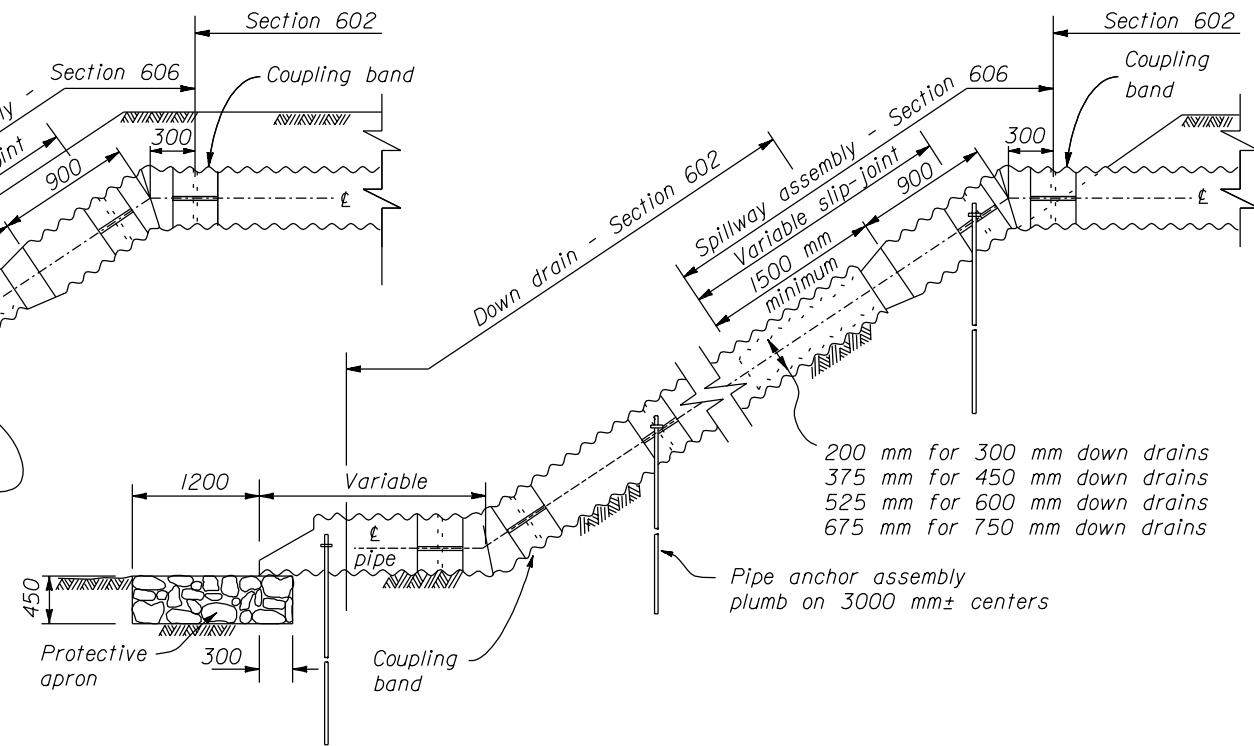

ELEVATION

SPILLWAY ASSEMBLY WITH SURFACE DOWN DRAIN

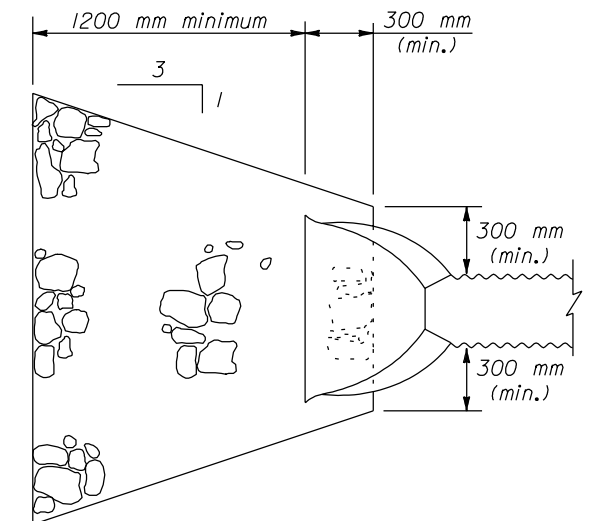

PLAN
PROTECTIVE APRON

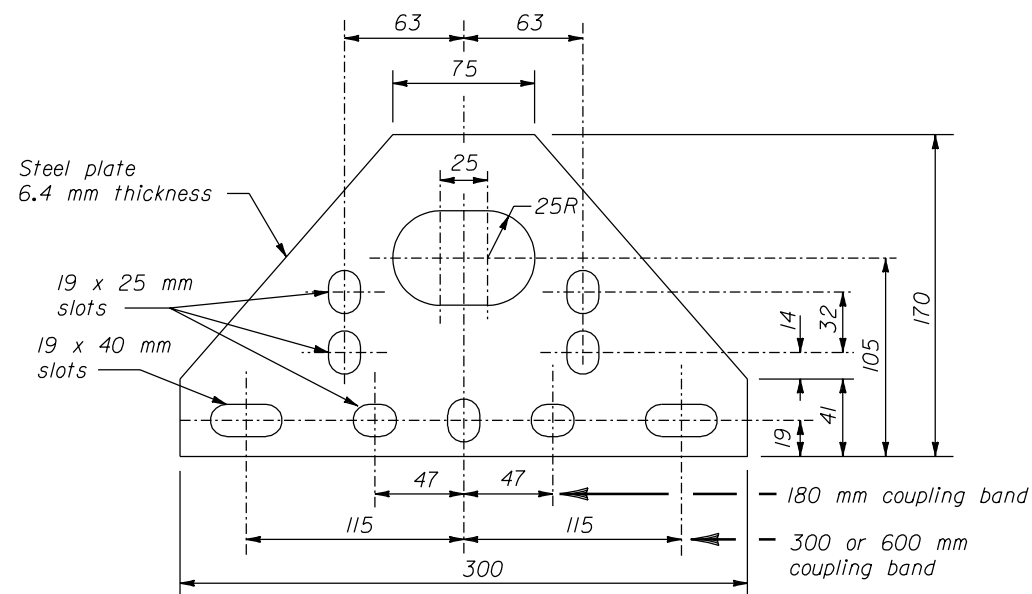

Measure length of coupling band parallel to the centerline of the pipe.

STEEL PLATE

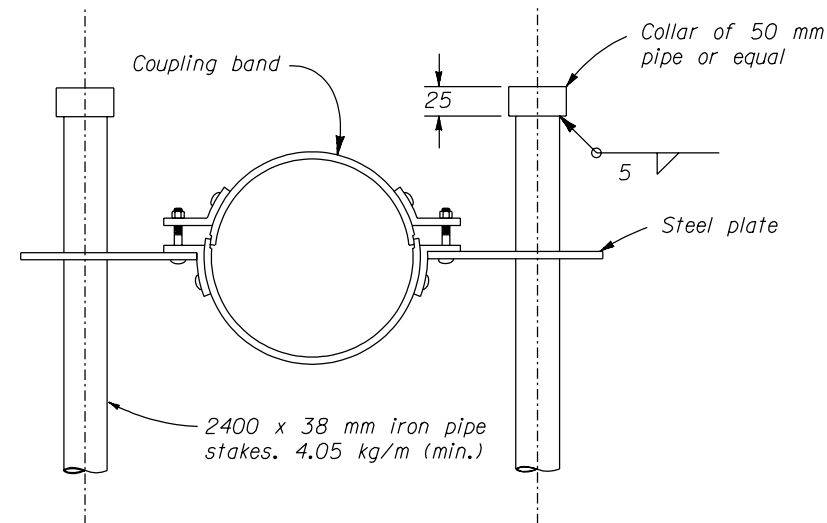

ANCHOR ASSEMBLY

NO SCALE

U.S. DEPARTMENT OF TRANSPORTATION FEDERAL HIGHWAY ADMINISTRATION WESTERN FEDERAL LANDS HIGHWAY DIVISION	
METRIC DETAIL	
SPILLWAY ASSEMBLY WITH DOWN DRAIN AND SLIP-JOINT	
DETAIL APPROVED FOR USE 3/1996	DETAIL
REVISED:	WM606-51

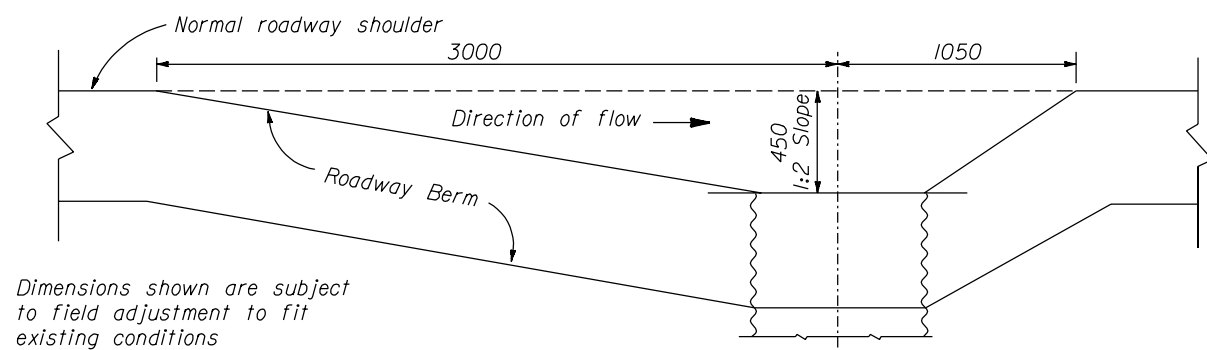

Dimensions shown are subject to field adjustment to fit existing conditions

PLAN
SPILLWAY ASSEMBLY

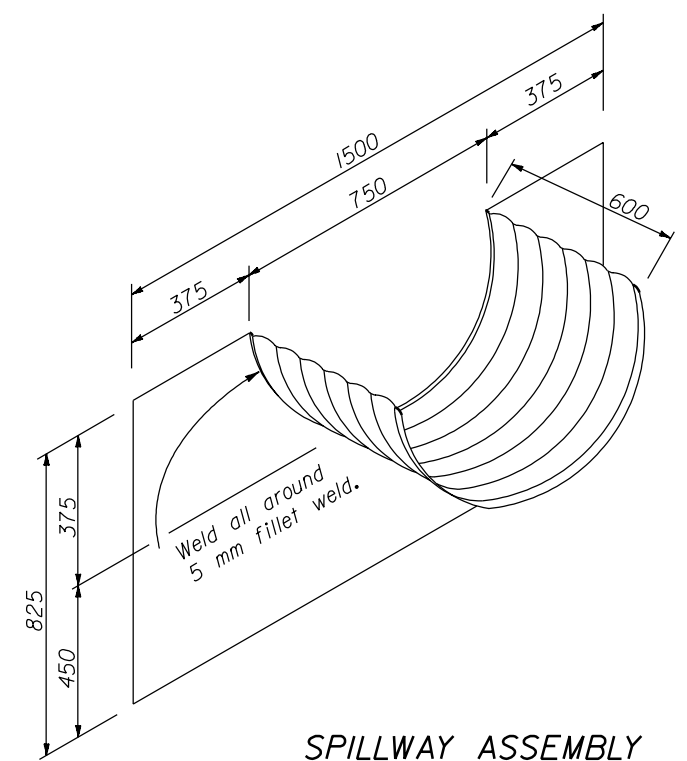

SPILLWAY ASSEMBLY

- NOTE:**
1. Dimensions not labeled are in millimeters.
 2. Fabricate spillway assembly from 1.6 mm thick galvanized steel or 1.5 mm aluminum.
 3. Place Class 2 riprap conforming to Section 251 for protective apron.
 4. Construct down drain from annular corrugated pipe, or from helically corrugated pipe with factory annular or flanged reformed ends.
 5. Furnish hardware in the metric sizes shown. Equivalent imperial sizes may be used when metric sizes are not available.
 6. Approved alternate designs may be used.

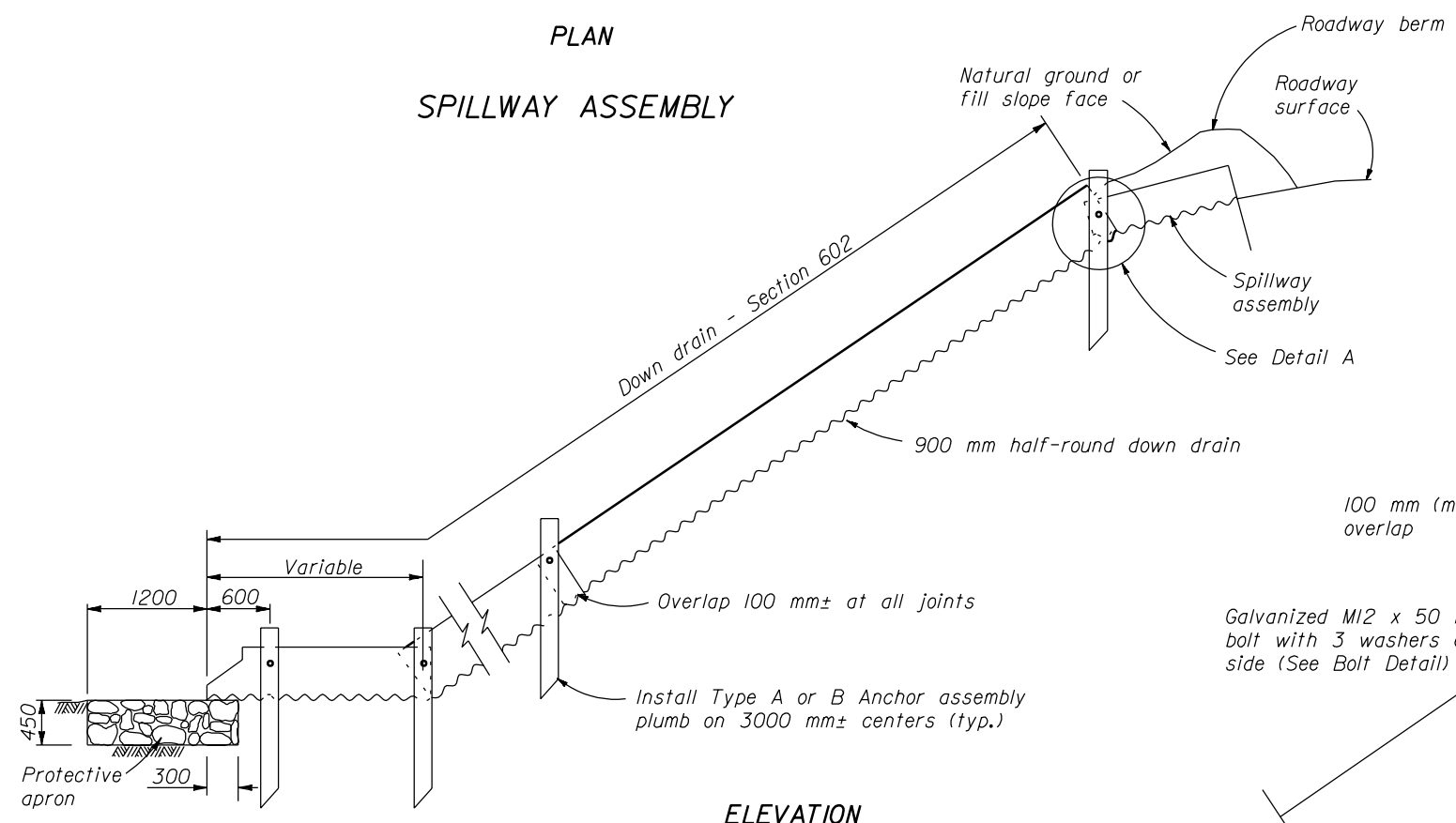

ELEVATION
SPILLWAY ASSEMBLY AND DOWN DRAIN

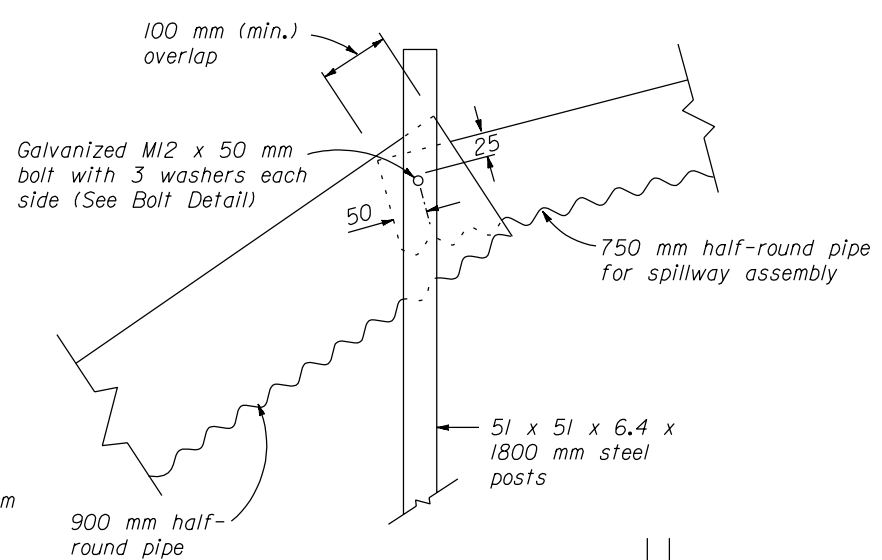

DETAIL A

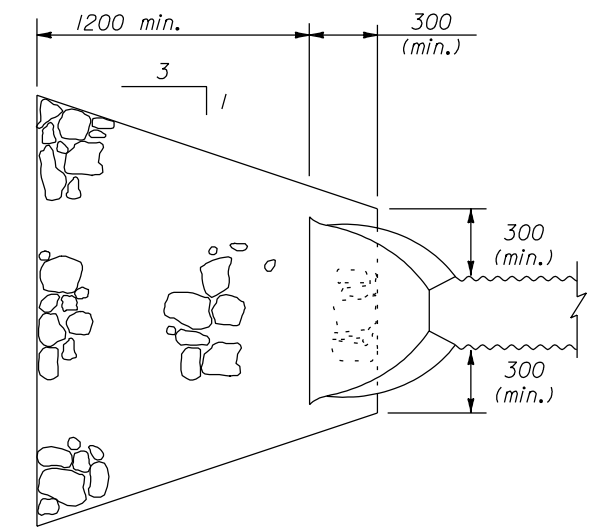

PLAN
PROTECTIVE APRON

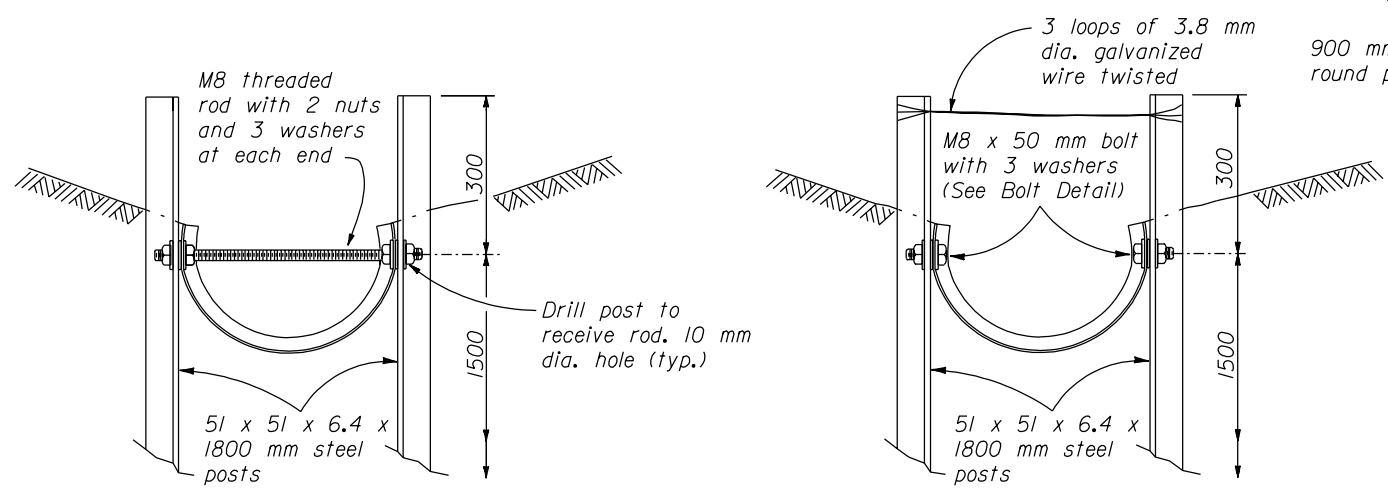

TYPE A

ANCHOR ASSEMBLY

TYPE B

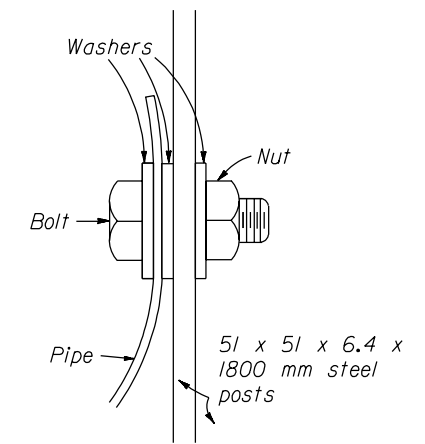

BOLT DETAIL

U.S. DEPARTMENT OF TRANSPORTATION
FEDERAL HIGHWAY ADMINISTRATION
WESTERN FEDERAL LANDS HIGHWAY DIVISION

METRIC DETAIL

**SPILLWAY ASSEMBLY WITH
HALF-ROUND DOWN DRAIN**

DETAIL APPROVED FOR USE 3/1996
REVISED: 3/1999 3/2000

DETAIL
WM606-52

NO SCALE

f:\standrow\metric\details\wm60652.dgn 13 DEC 2000

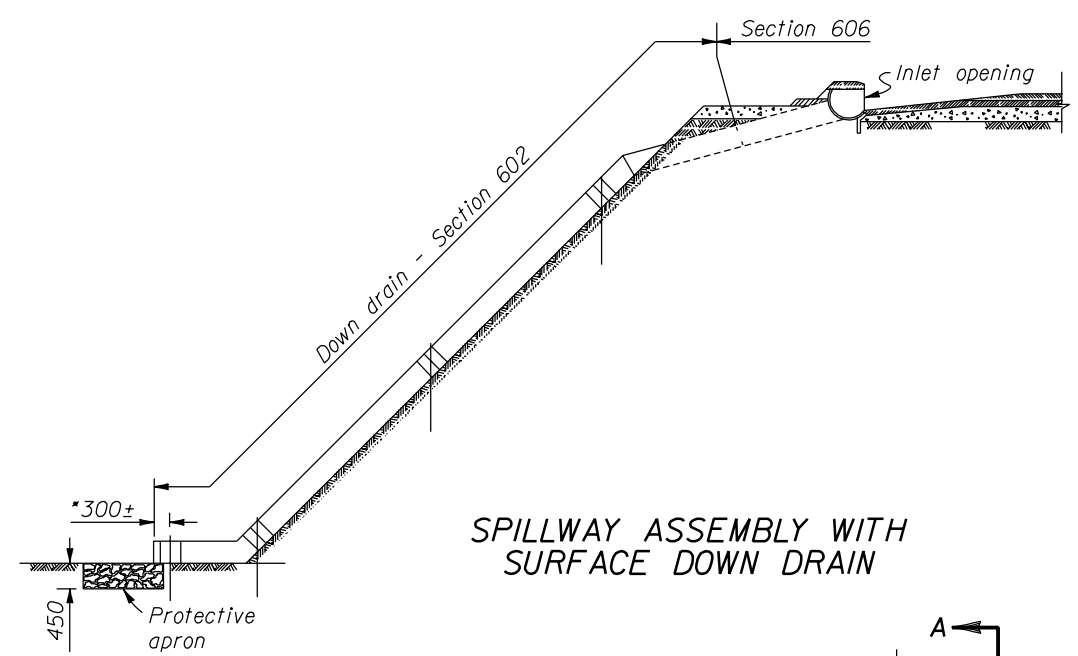

SPILLWAY ASSEMBLY WITH SURFACE DOWN DRAIN

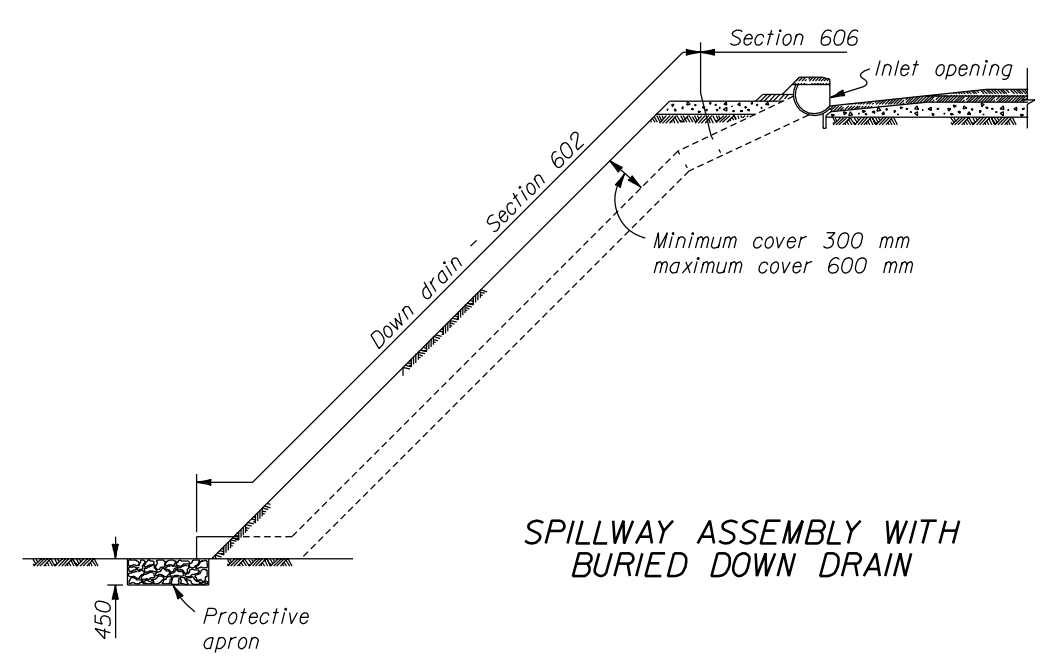

SPILLWAY ASSEMBLY WITH BURIED DOWN DRAIN

- NOTE:**
- Dimensions not labeled are in millimeters.
 - Fabricate half-round pipe, outlet pipe, and curtain wall for spillway assembly from 1.6 mm galvanized steel or 1.5 mm aluminum. Fabricate top plate and end plate from 4.6 mm flat steel or 5.0 mm aluminum plate. Fabricate tapered portion of slip joint from either flat or corrugated sheets.
 - Make all coupling band connections watertight by placing a 5 mm bead of approved caulking under each half of the band before tightening.
 - Install pipe anchor assemblies at 3000 mm± spacing on down drain installed above ground.
 - Use Type 2 spillway assembly inlets where profile grades are greater than 2 percent. Use Type 1 on grades 2 percent or flatter.
 - Place class 2 riprap conforming to Section 251 for protective apron.
 - Galvanized items of the anchor assembly after fabrication.
 - Furnish hardware in the metric sizes shown. Equivalent imperial sizes may be used when metric sizes are not available.
 - Approved alternate designs may be used.

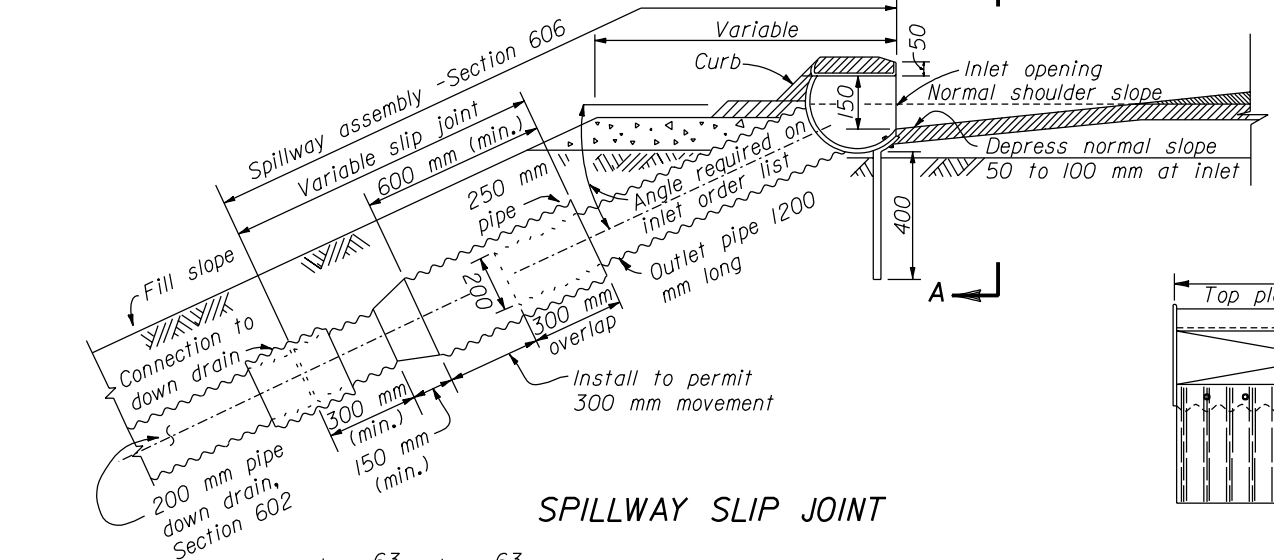

SPILLWAY SLIP JOINT

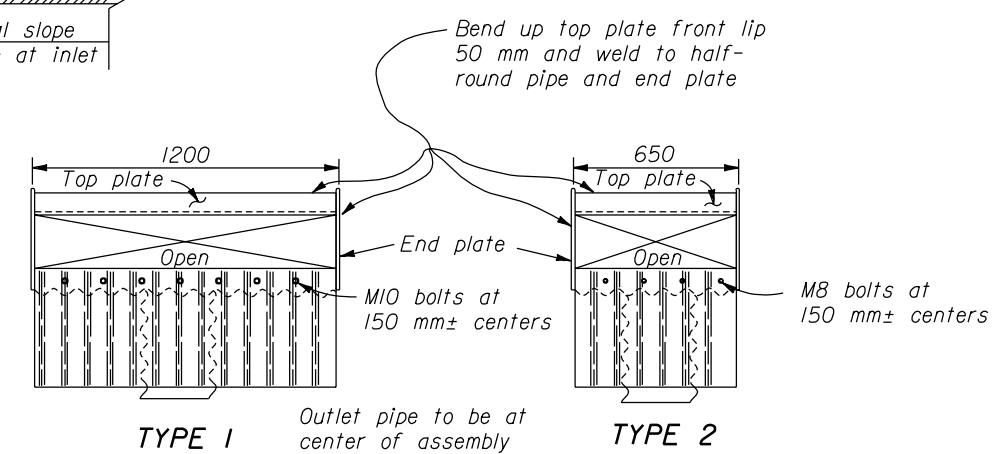

SECTION A-A SPILLWAY ASSEMBLY INLETS

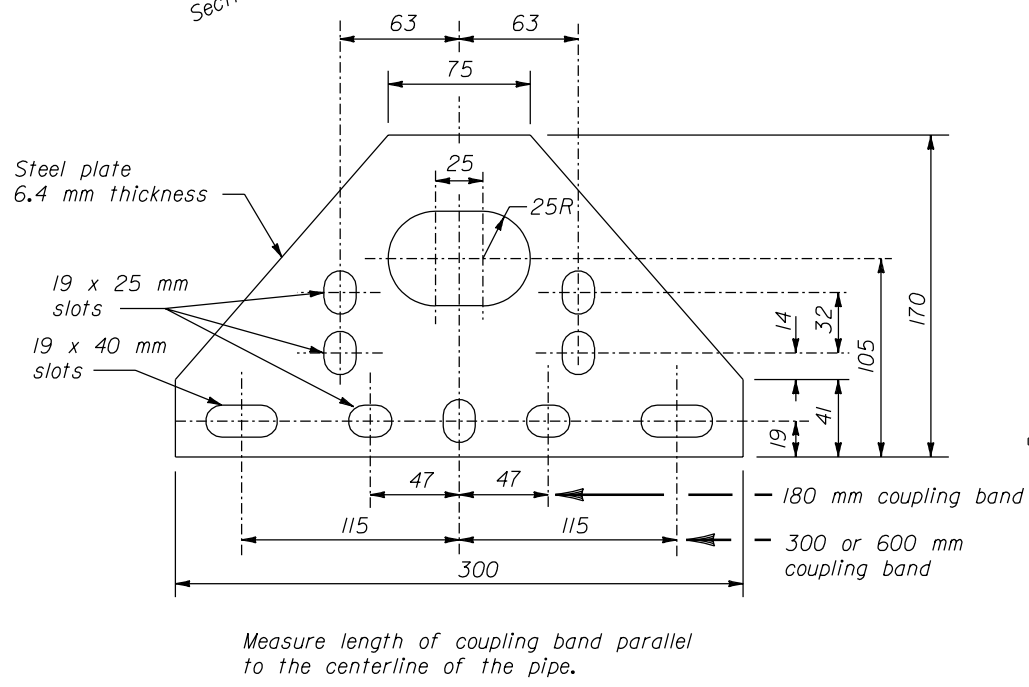

STEEL PLATE

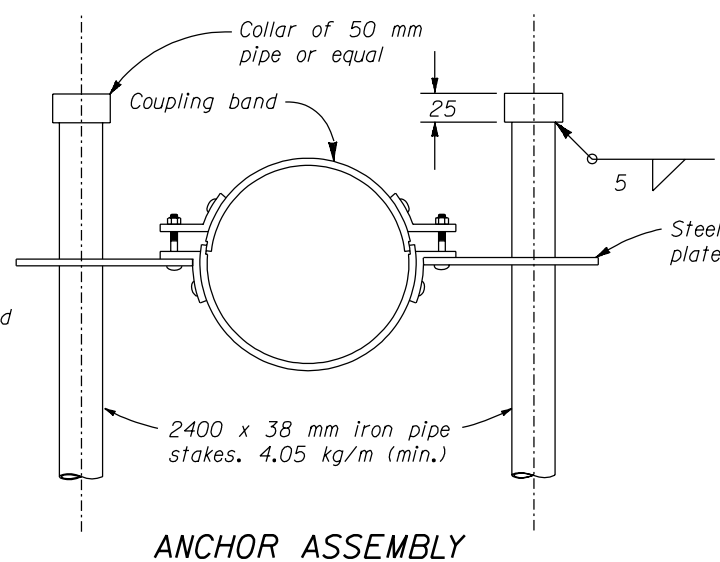

ANCHOR ASSEMBLY

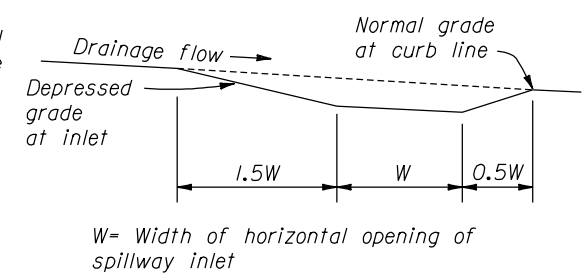

SCHEMATIC PROFILE OF INLET BASIN

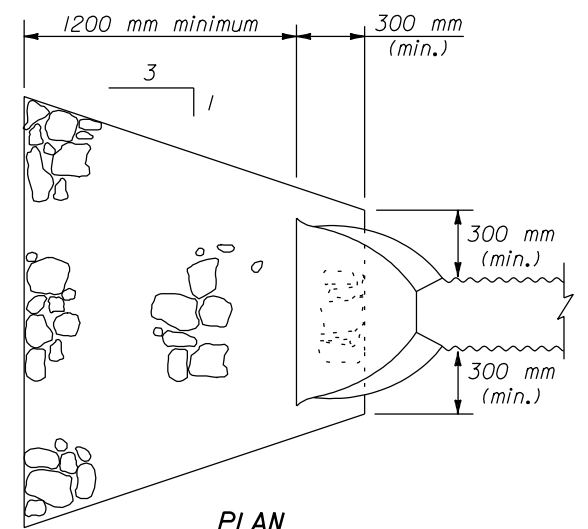

PLAN PROTECTIVE APRON

U.S. DEPARTMENT OF TRANSPORTATION
FEDERAL HIGHWAY ADMINISTRATION
WESTERN FEDERAL LANDS HIGHWAY DIVISION

METRIC DETAIL

CORRUGATED METAL SPILLWAYS AND INLETS

DETAIL APPROVED FOR USE 3/1996
REVISID:

DETAIL
WM606-53

NO SCALE

13 DEC 2000 f:\standrow\metric\details\wm60653.dgn

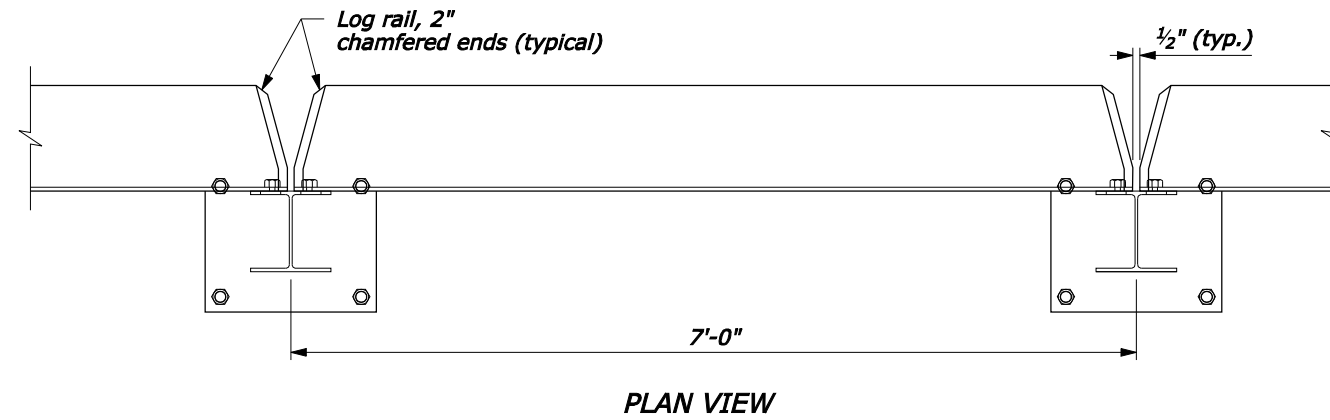

NOTE:

1. Steel is ASTM A242 or A588, Grade 50.
2. Concrete: minimum $f_c' = 3500$ psi.

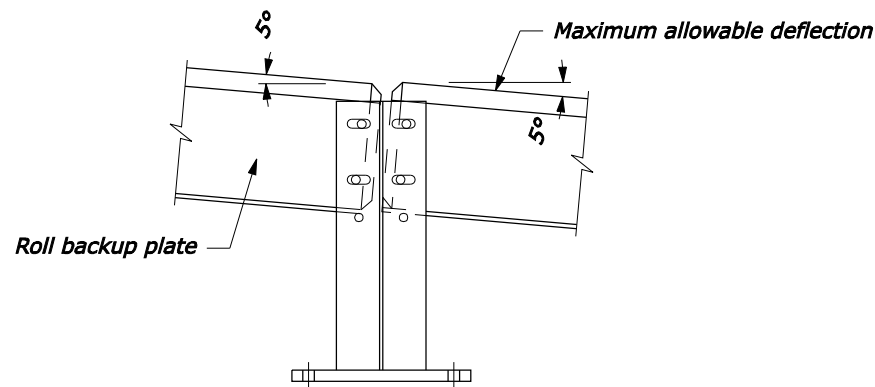

**ENDS OF RAILS AT POST:
MAXIMUM VERTICAL
DEFLECTION ALLOWABLE
ELEVATION**

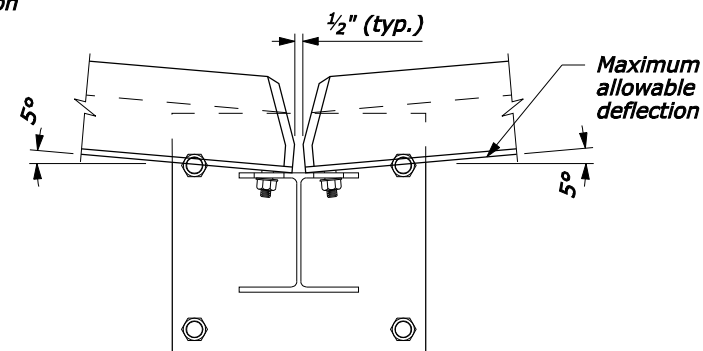

**MAXIMUM HORIZONTAL
DEFLECTION ALLOWABLE
PLAN VIEW**

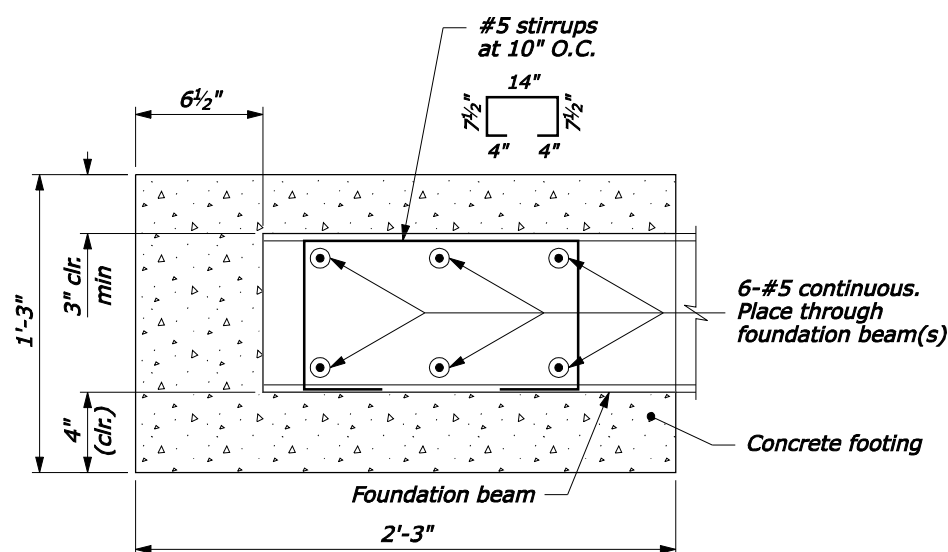
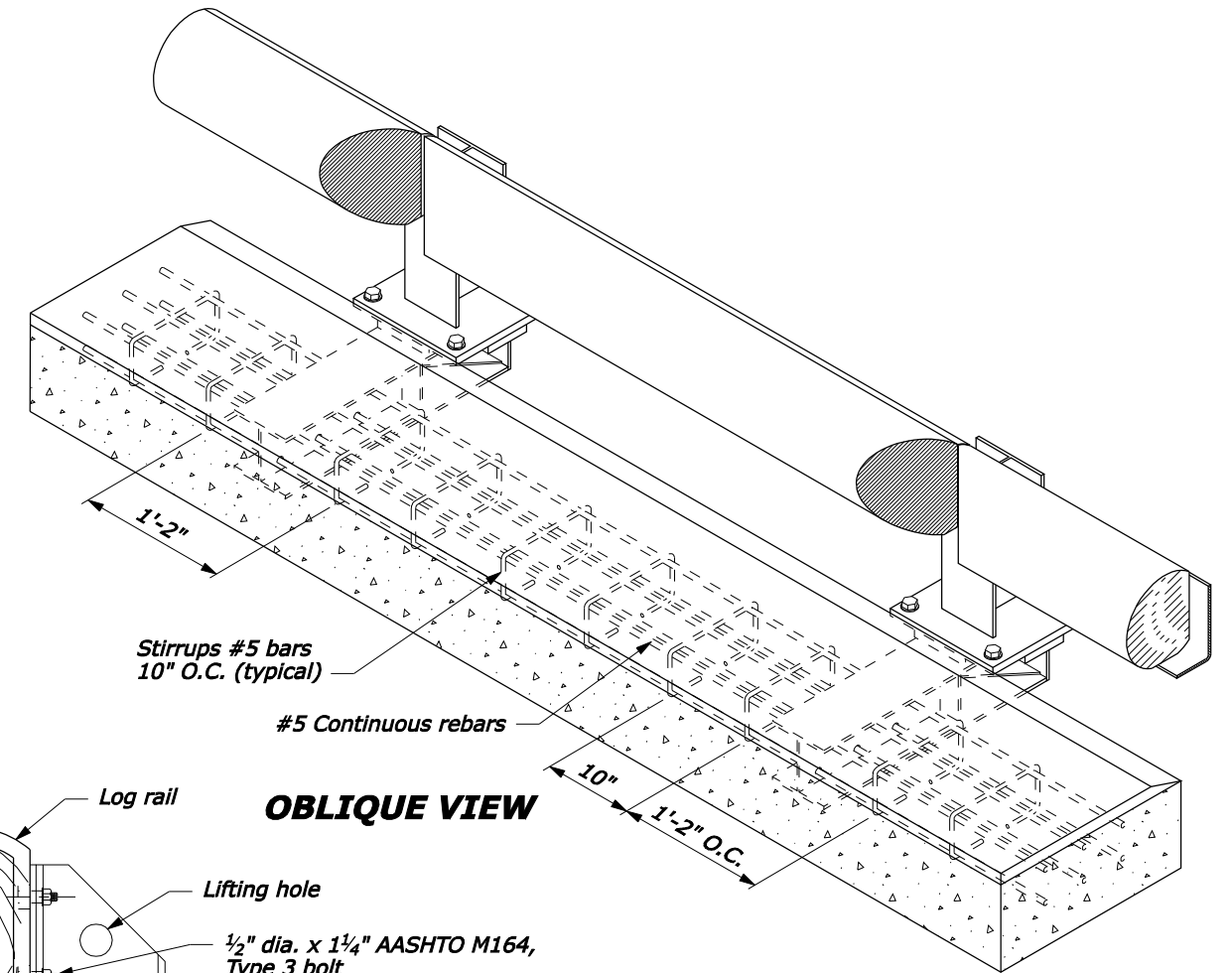

**FOOTING DETAIL
TYPICAL SECTION**

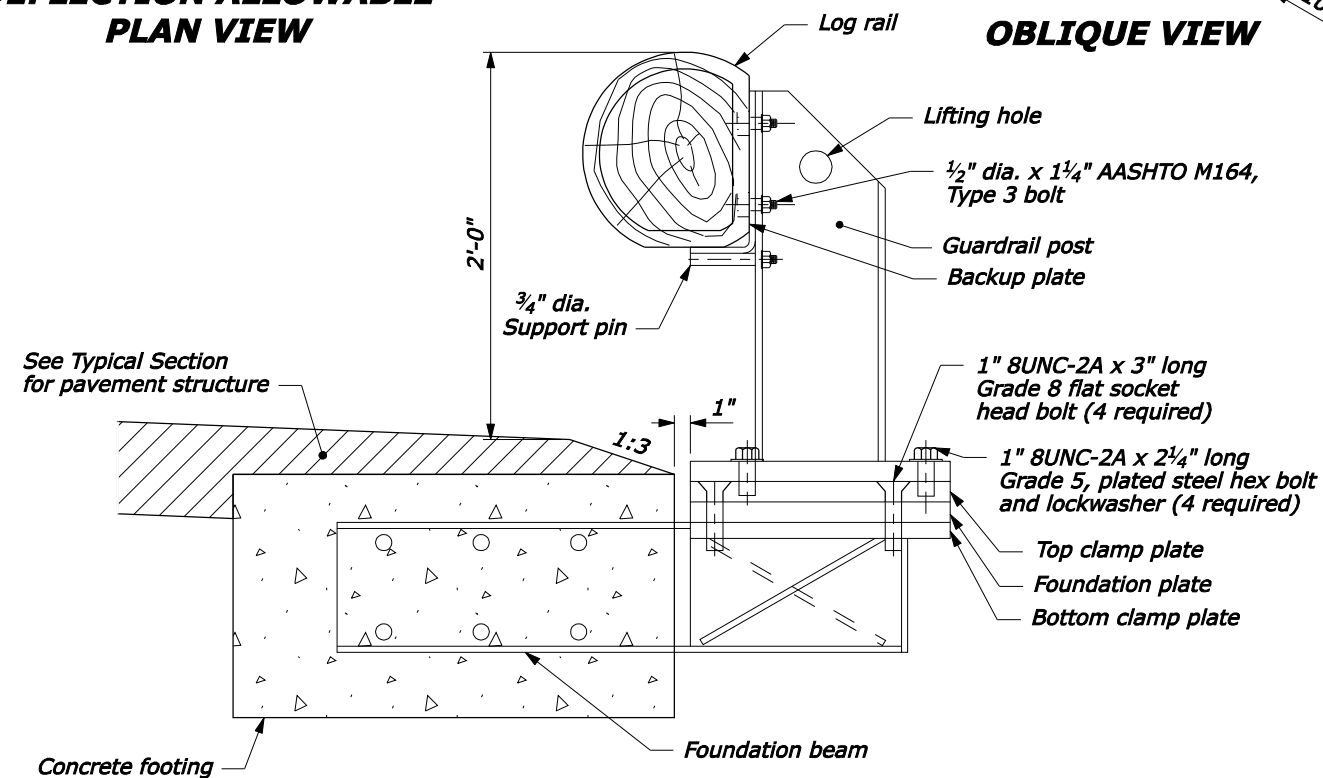

TYPICAL SECTION

NO SCALE

U.S. DEPARTMENT OF TRANSPORTATION
FEDERAL HIGHWAY ADMINISTRATION
WESTERN FEDERAL LANDS HIGHWAY DIVISION

U.S. CUSTOMARY DETAIL
**REMOVABLE
STEEL-BACKED LOG RAIL**
Sheet 1 of 3

DETAIL APPROVED FOR USE 3/2009	DETAIL
REVISED:	W617-83

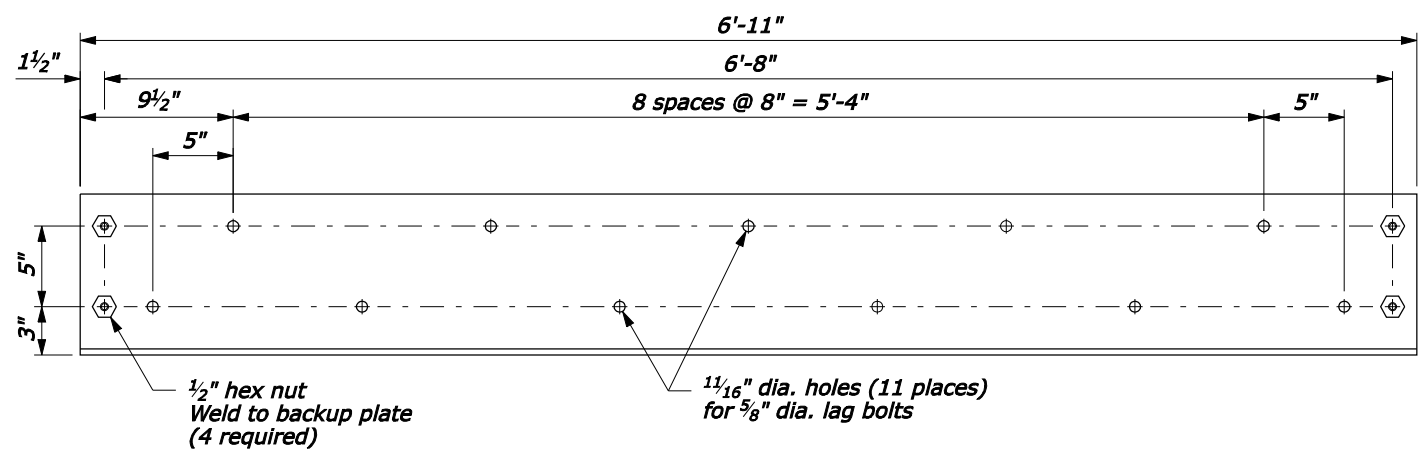

**RAIL BACKUP PLATE
ELEVATION VIEW**

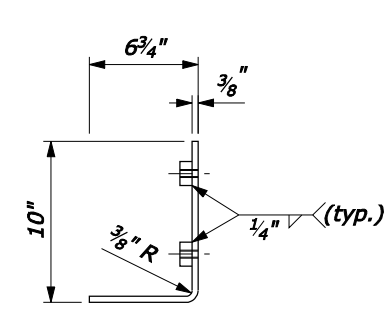

**RAIL BACKUP PLATE
SECTION VIEW**

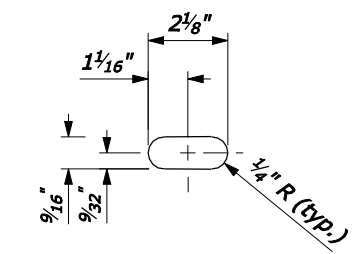

TYPICAL SLOT DETAIL

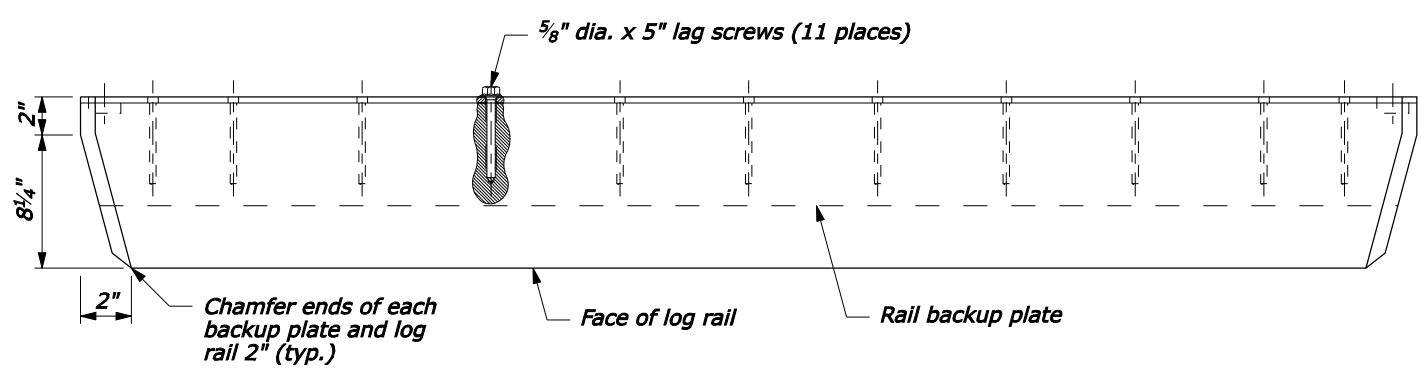

**LOG RAIL & RAIL BACKUP PLATE
PLAN VIEW**

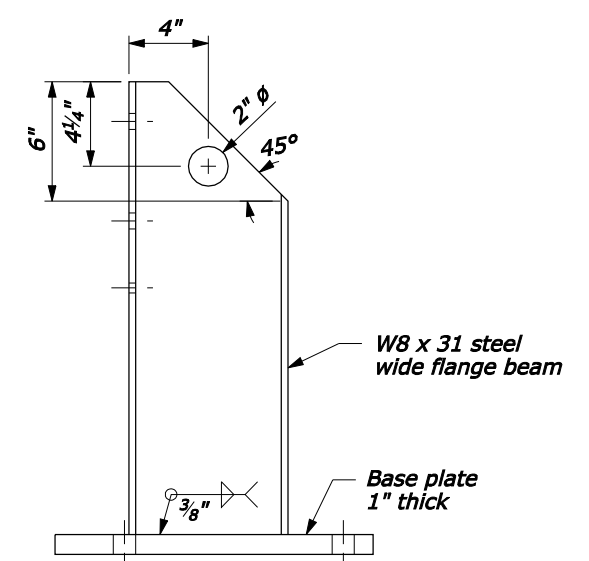
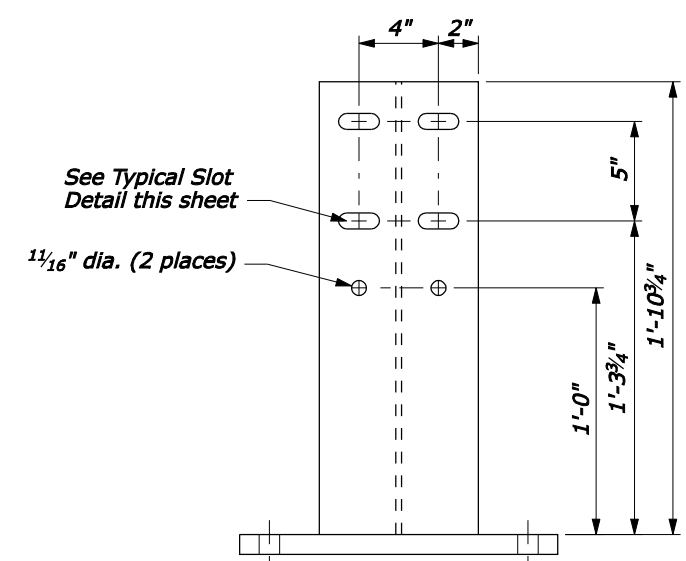

GUARDRAIL POST

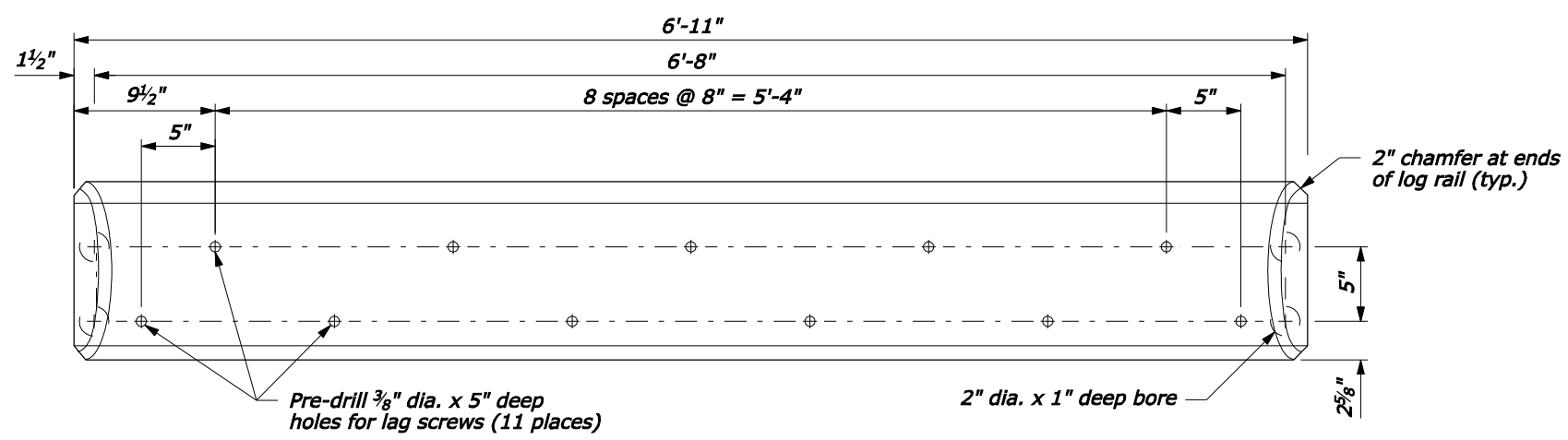

**LOG RAIL
ELEVATION VIEW**

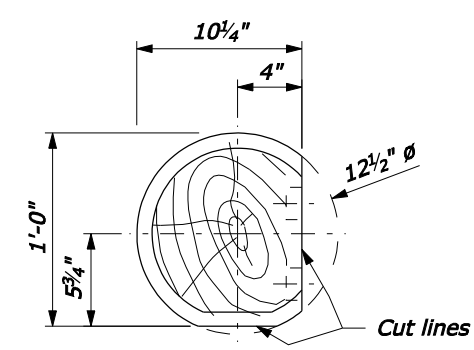

**LOG RAIL
SECTION VIEW**

NO SCALE

U.S. DEPARTMENT OF TRANSPORTATION FEDERAL HIGHWAY ADMINISTRATION WESTERN FEDERAL LANDS HIGHWAY DIVISION	
U.S. CUSTOMARY DETAIL	
REMOVABLE STEEL-BACKED LOG RAIL	
Sheet 2 of 3	
DETAIL APPROVED FOR USE 3/2009	DETAIL
REVISED:	W617-83

2211428-b-Y1:M 00000000
 Pp://198.145.186.2/std.pln/w61783.dgn [US Customary]

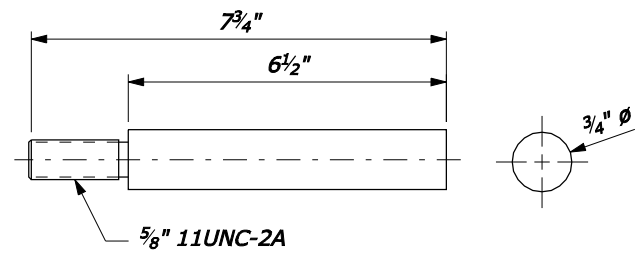

SUPPORT PIN

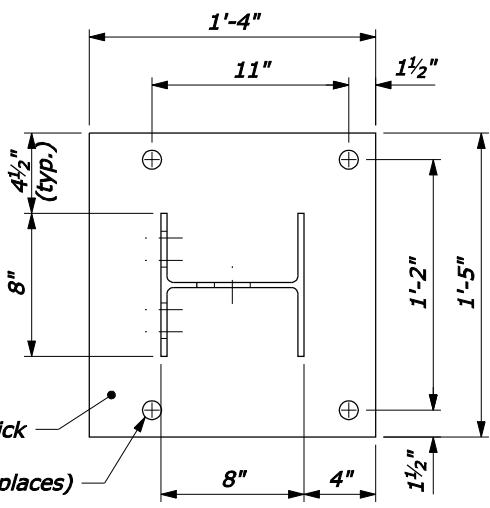
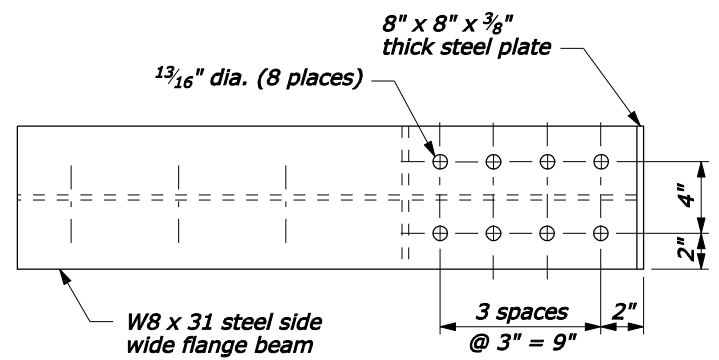

RAIL POST BASE PLATE

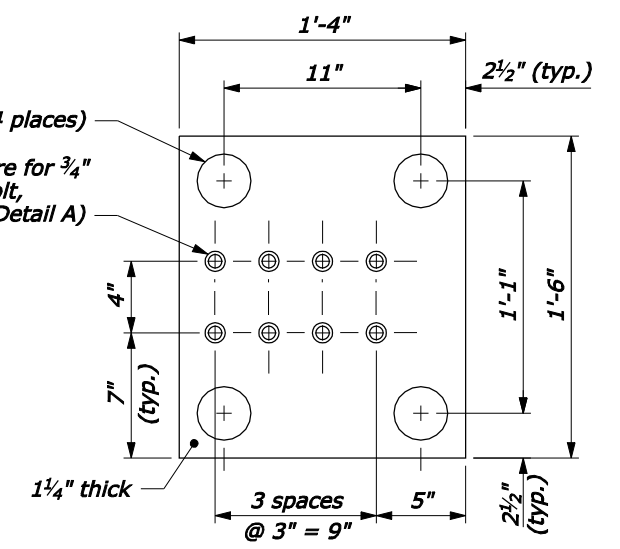

FOUNDATION PLATE

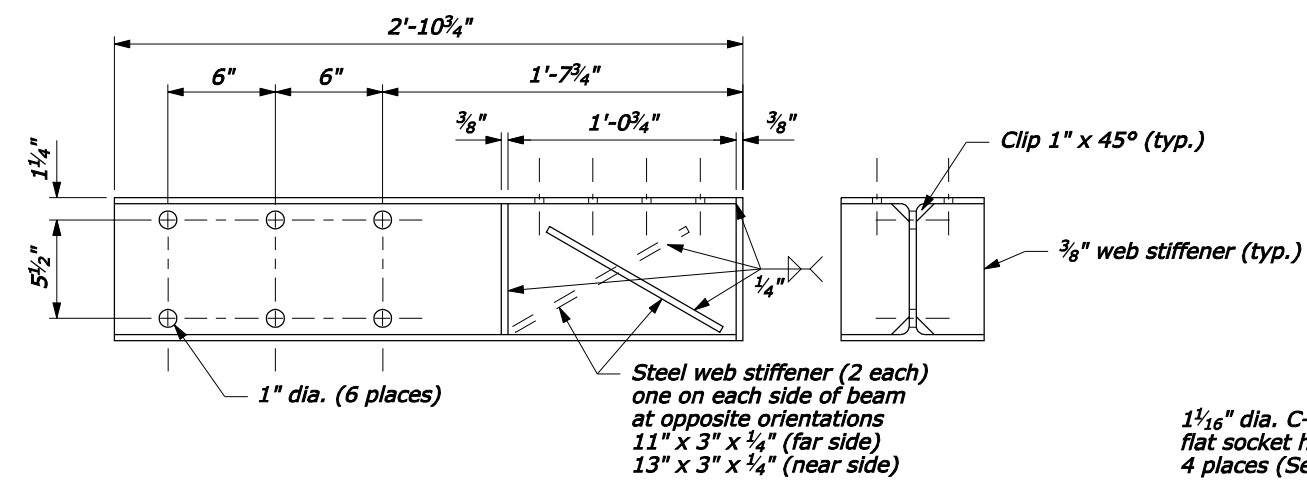

FOUNDATION BEAM

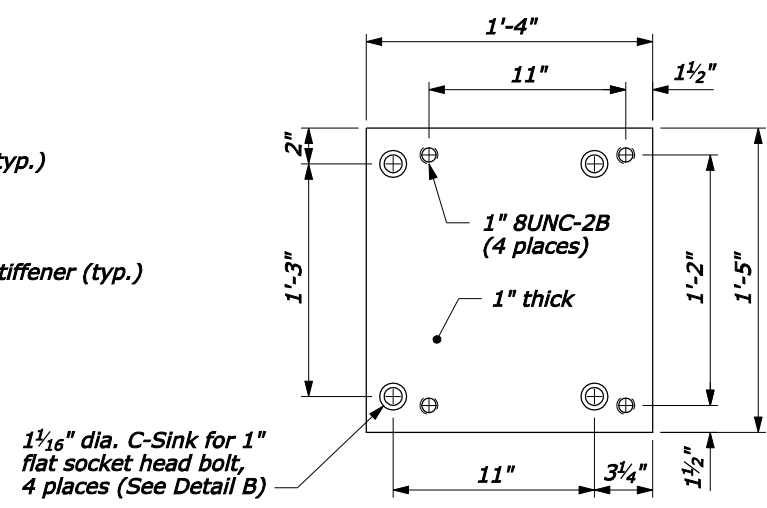

TOP CLAMP PLATE

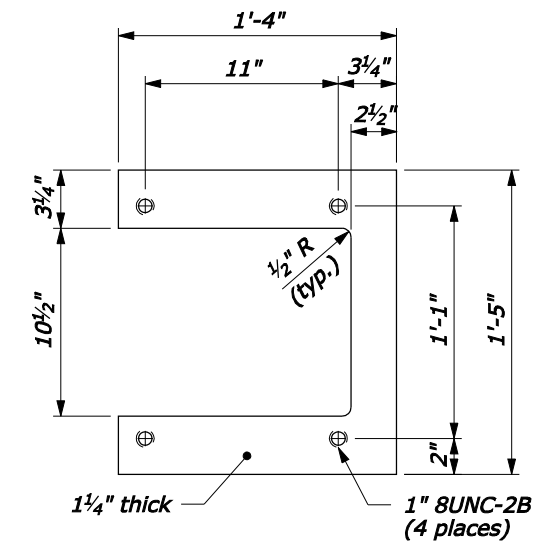

BOTTOM CLAMP PLATE

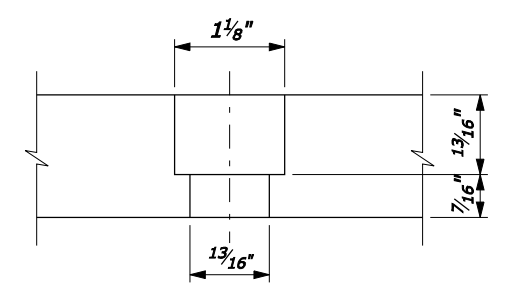

DETAIL A

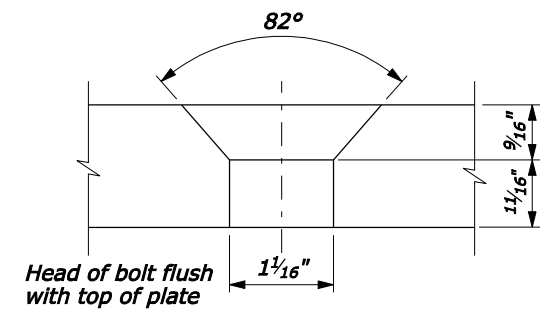

DETAIL B

NO SCALE

U.S. DEPARTMENT OF TRANSPORTATION
 FEDERAL HIGHWAY ADMINISTRATION
 WESTERN FEDERAL LANDS HIGHWAY DIVISION

U.S. CUSTOMARY DETAIL

**REMOVABLE
 STEEL-BACKED LOG RAIL**

Sheet 3 of 3

DETAIL APPROVED FOR USE 3/2009	DETAIL
REVISED:	W617-83

Rpt://198.145.186.2/std.pln/w61783.dgn [US Customary] 2211428-b-YIM 00000000

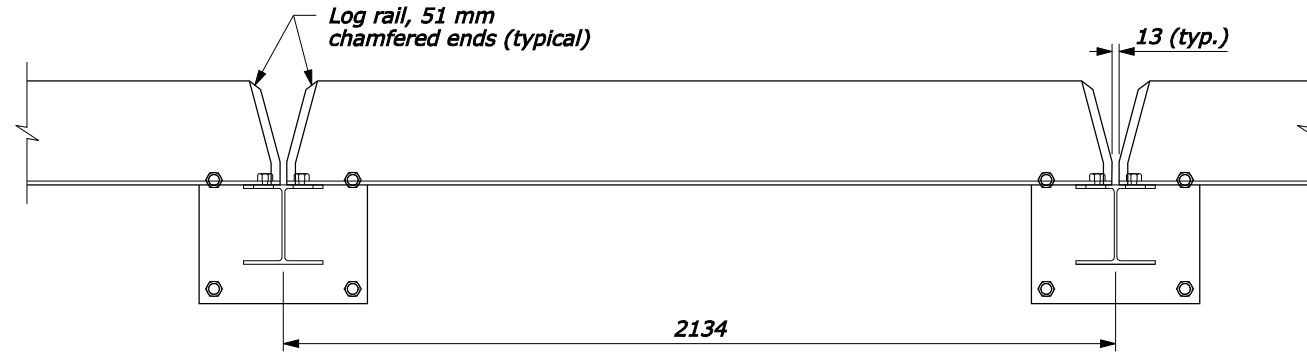

PLAN VIEW

NOTE:

1. Steel is ASTM A242 or A588, Grade 50.
2. Concrete: minimum $f'c = 24$ MPa.
3. Furnish hardware in equivalent U.S. Customary sizes.
4. Dimensions without units are millimeters.

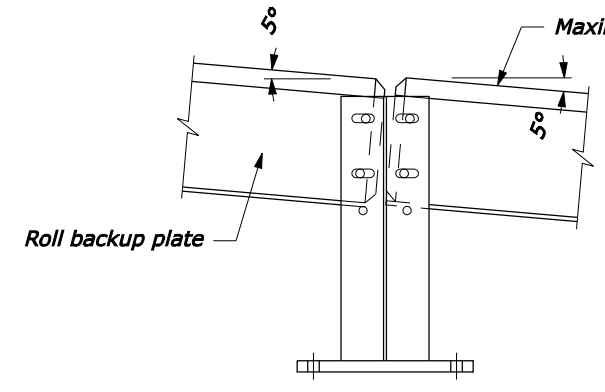

**ENDS OF RAILS AT POST:
MAXIMUM VERTICAL
DEFLECTION ALLOWABLE
ELEVATION**

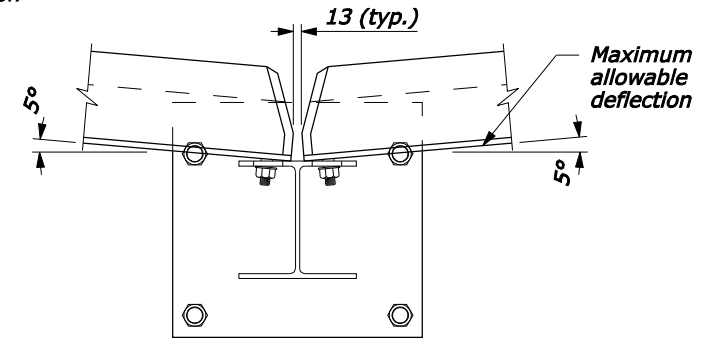

**MAXIMUM HORIZONTAL
DEFLECTION ALLOWABLE
PLAN VIEW**

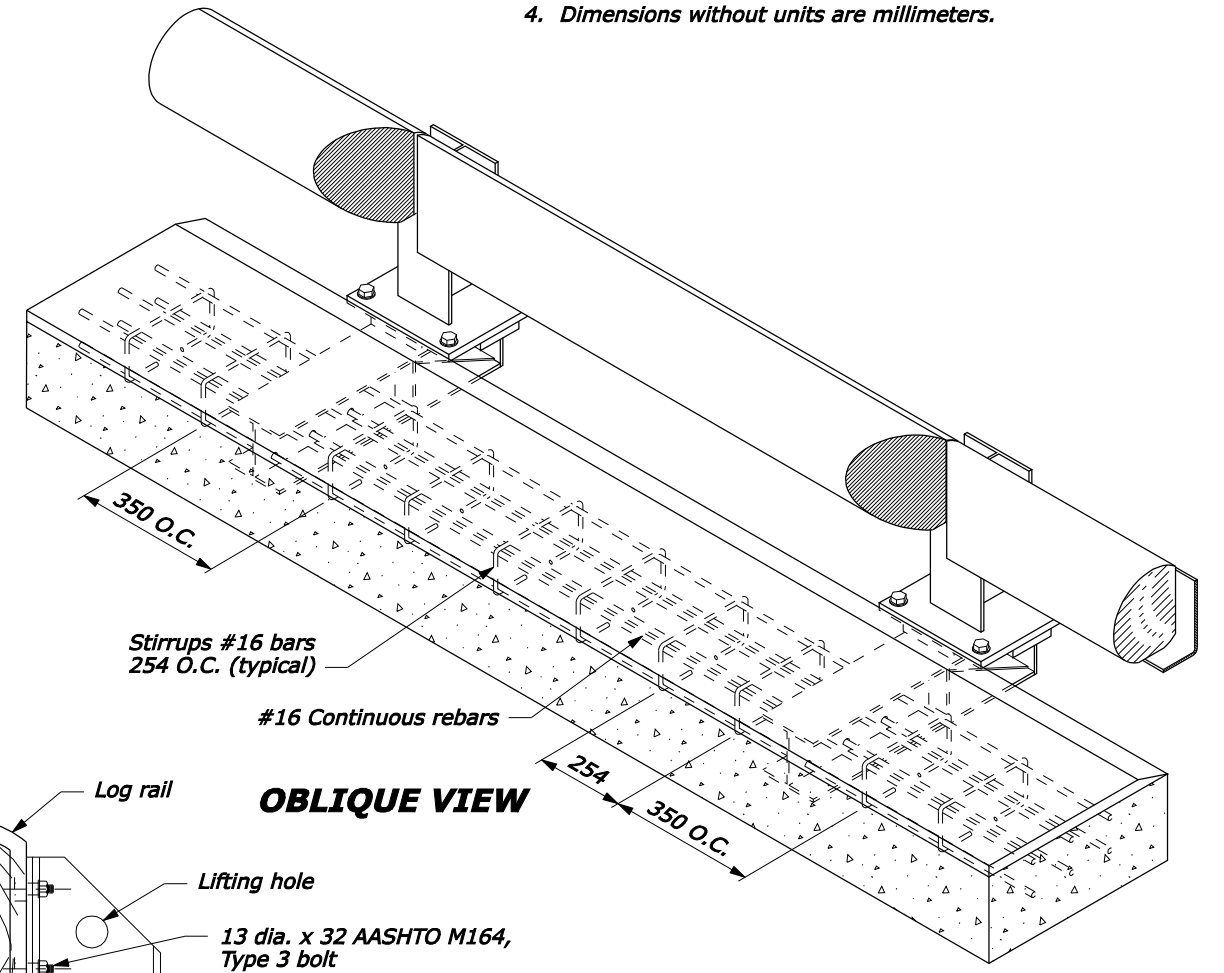

OBLIQUE VIEW

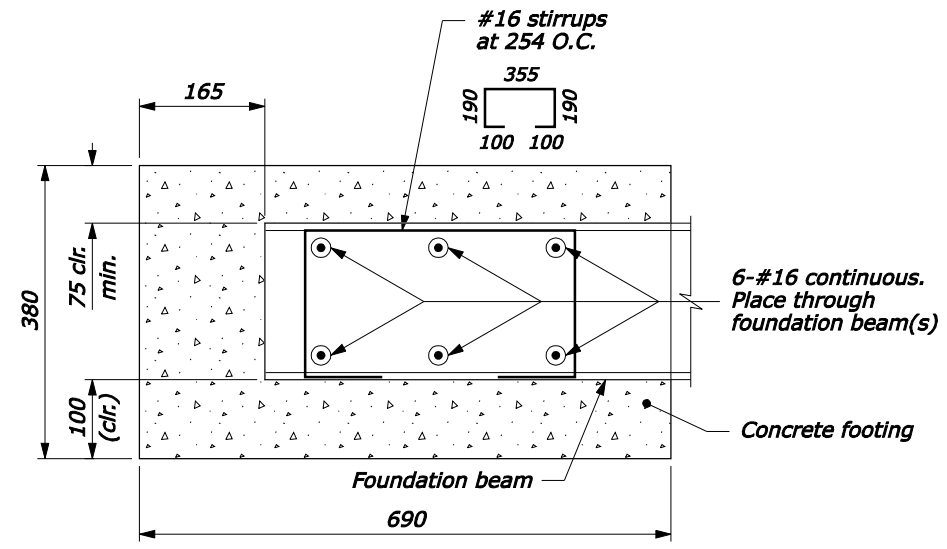

**FOOTING DETAIL
TYPICAL SECTION**

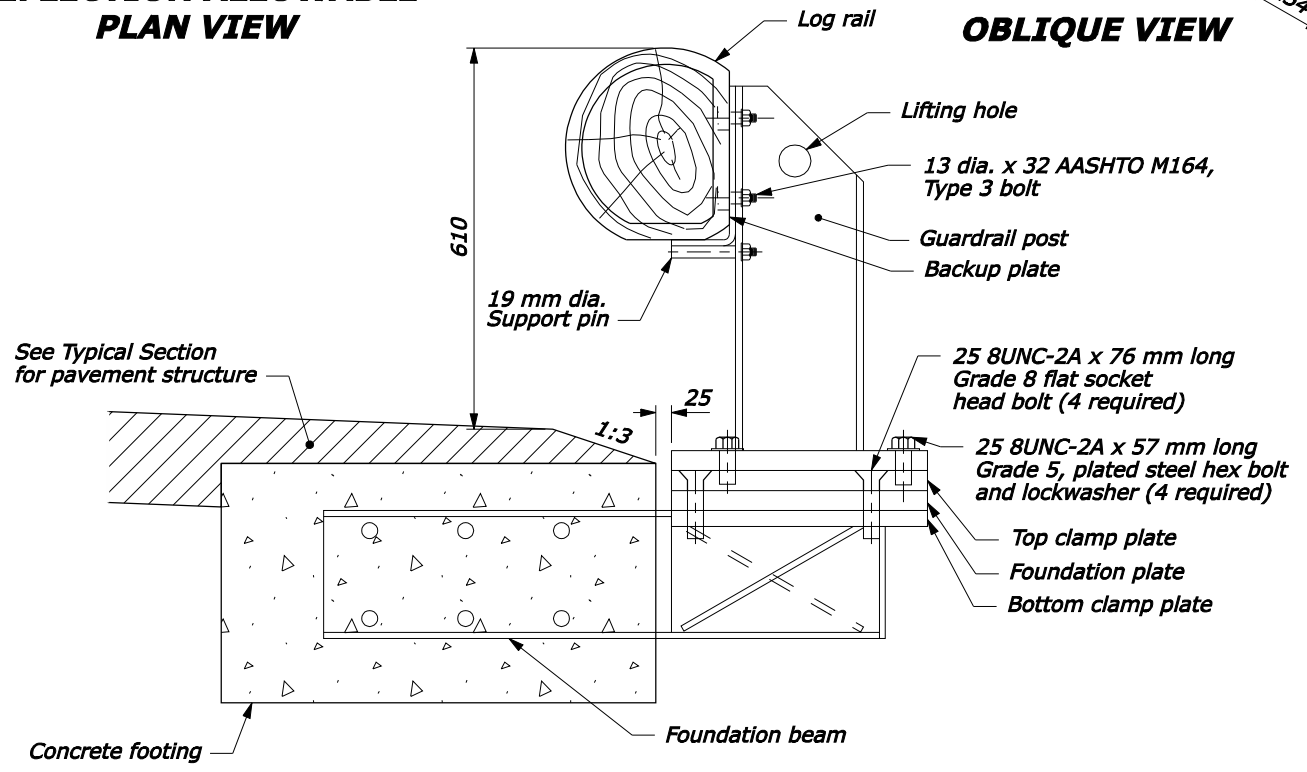

TYPICAL SECTION

U.S. DEPARTMENT OF TRANSPORTATION
FEDERAL HIGHWAY ADMINISTRATION
WESTERN FEDERAL LANDS HIGHWAY DIVISION

METRIC DETAIL
REMOVABLE
STEEL-BACKED LOG RAIL
Sheet 1 of 3

DETAIL APPROVED FOR USE 3/2009
REVISID:

DETAIL
WM617-83

NO SCALE

2211428-b-y 1:M 00000000
 fpp://196.145.188.2/scd_plan/wf/w61783.dgn [Metric]

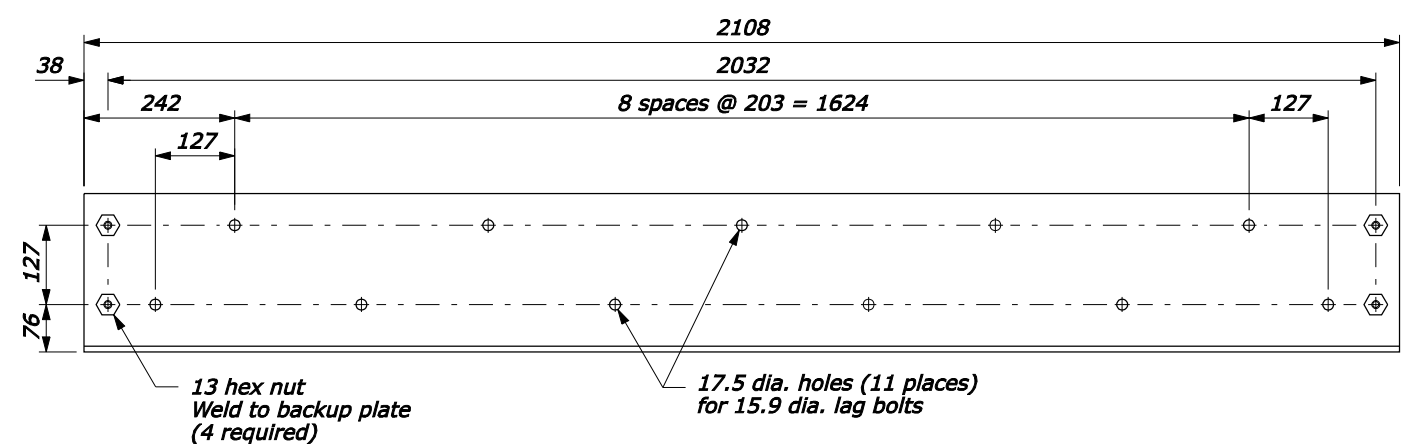

**RAIL BACKUP PLATE
ELEVATION VIEW**

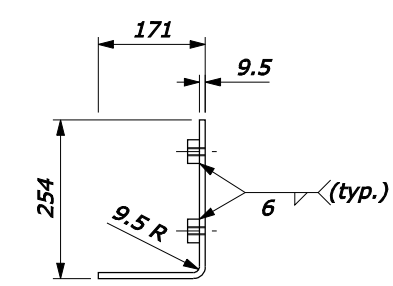

**RAIL BACKUP PLATE
SECTION VIEW**

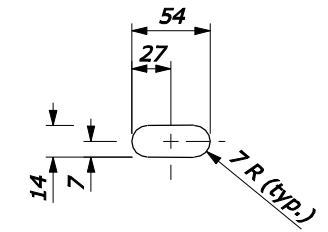

TYPICAL SLOT DETAIL

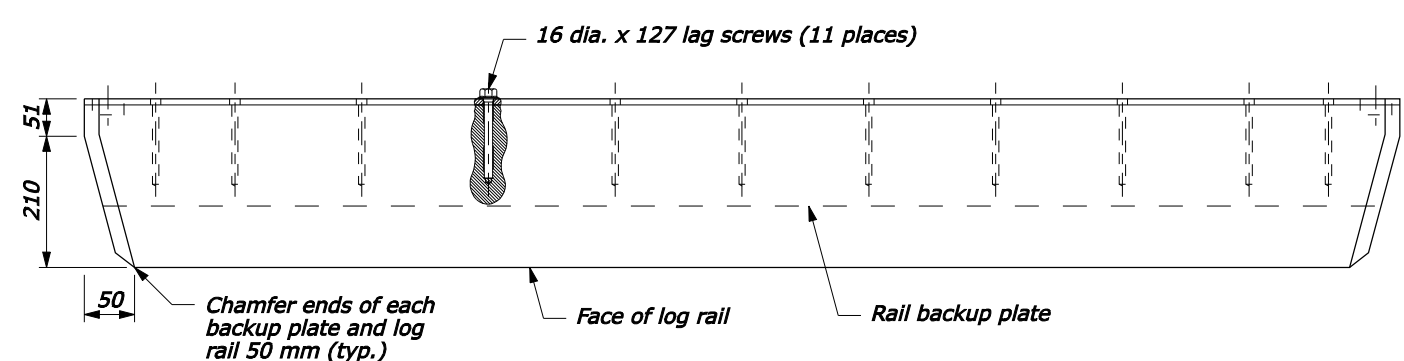

**LOG RAIL & RAIL BACKUP PLATE
PLAN VIEW**

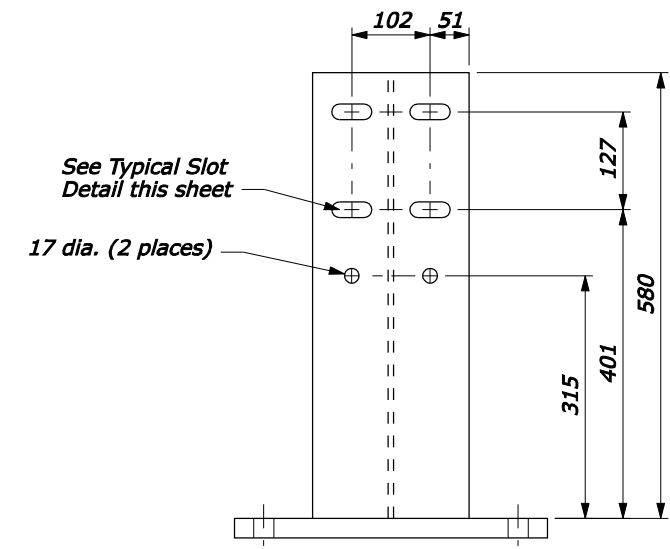

GUARDRAIL POST

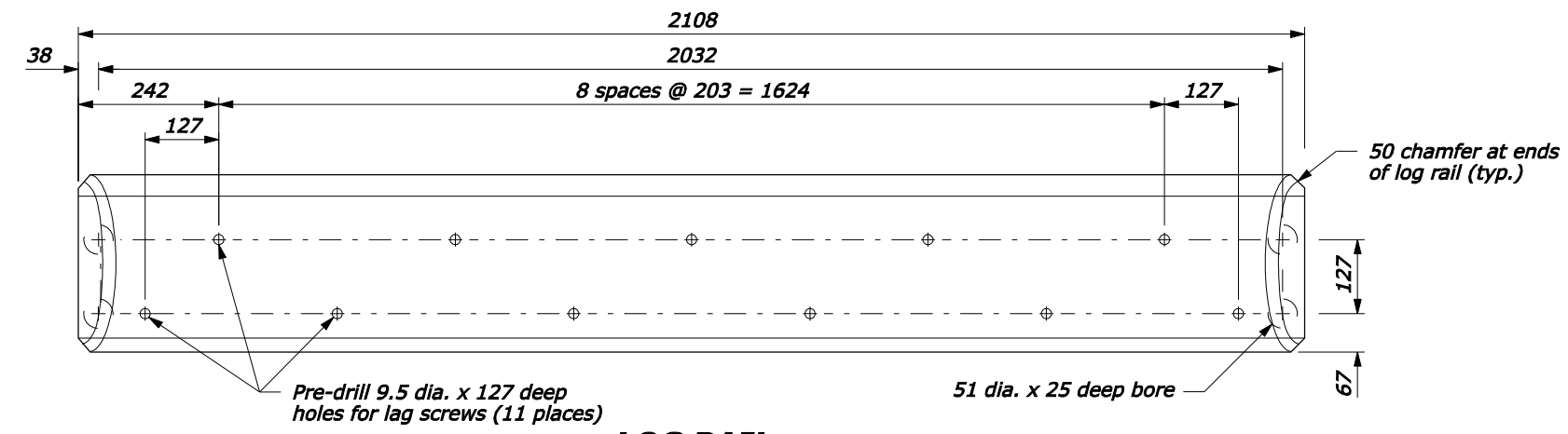
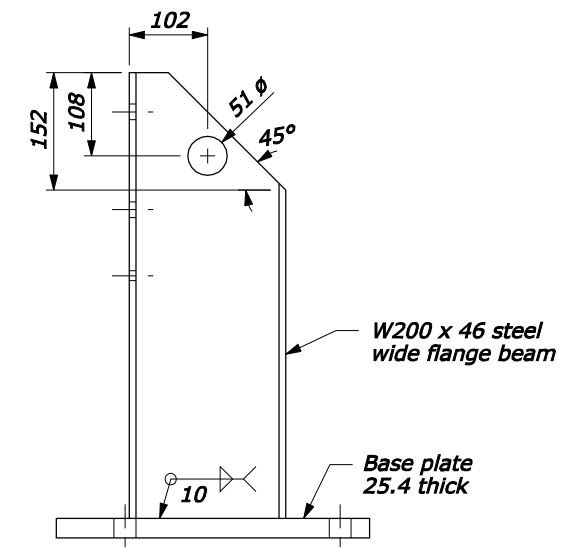

**LOG RAIL
ELEVATION VIEW**

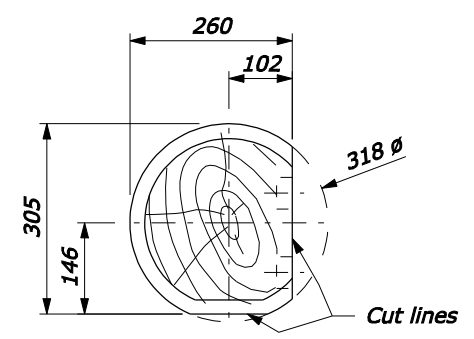

**LOG RAIL
SECTION VIEW**

NO SCALE

U.S. DEPARTMENT OF TRANSPORTATION FEDERAL HIGHWAY ADMINISTRATION WESTERN FEDERAL LANDS HIGHWAY DIVISION	
METRIC DETAIL	
REMOVABLE STEEL-BACKED LOG RAIL	
Sheet 2 of 3	
DETAIL APPROVED FOR USE 3/2009	DETAIL
REVISED:	WM617-83

2211428-B-Y 1:M 00000000
 fpp://196.145.188.2/scl_plan/wf/w61783.dgn [Metric]

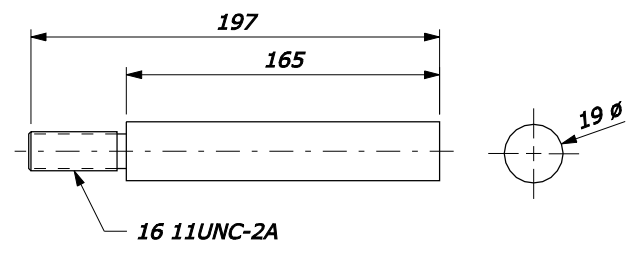

SUPPORT PIN

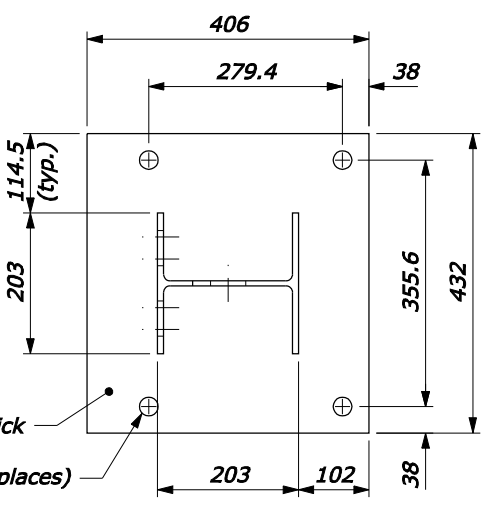
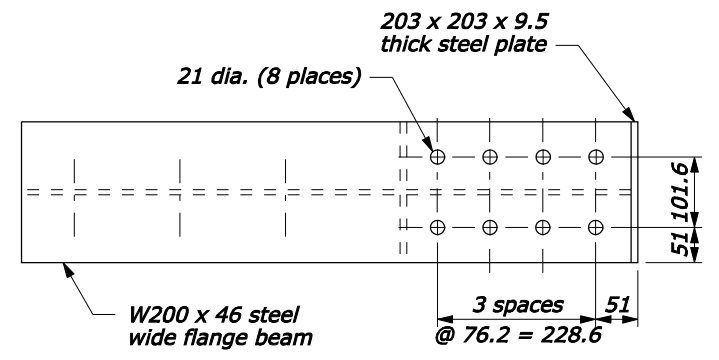

RAIL POST BASE PLATE

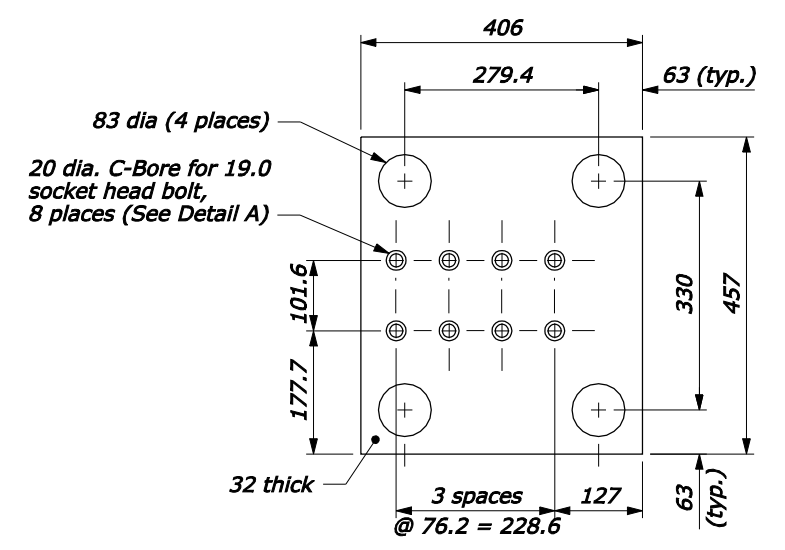

FOUNDATION PLATE

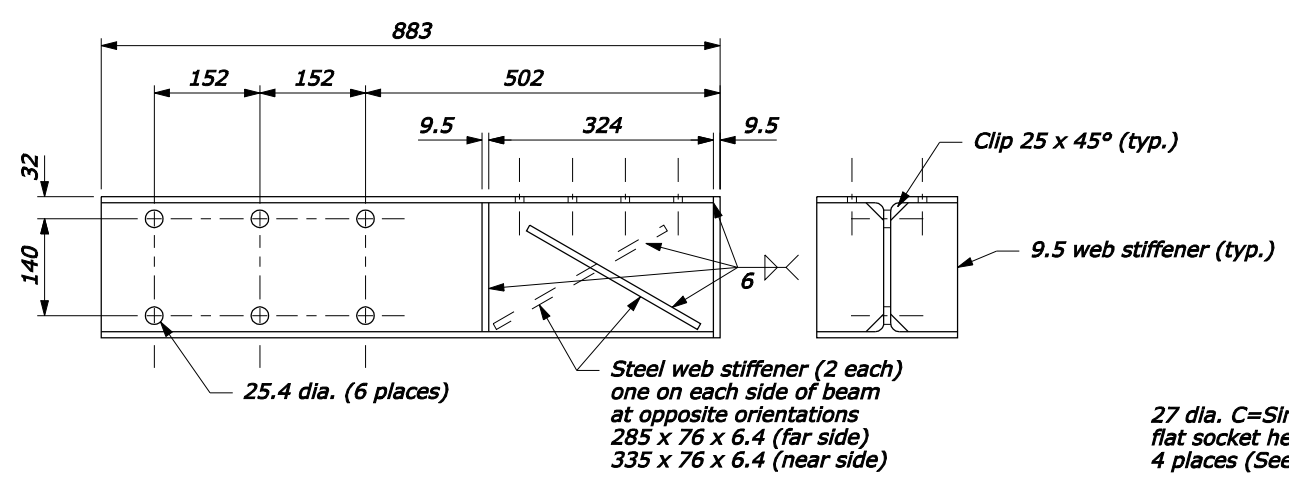

FOUNDATION BEAM

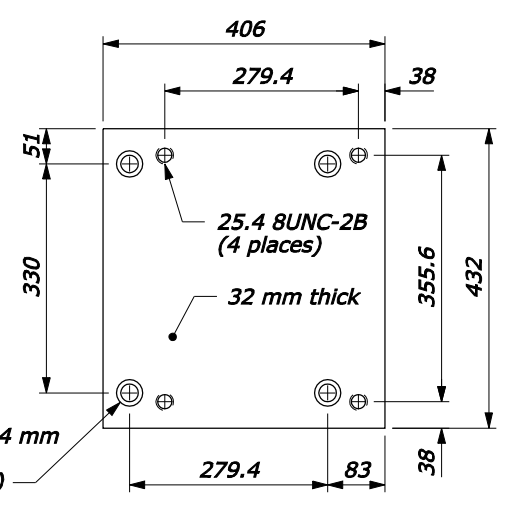

TOP CLAMP PLATE

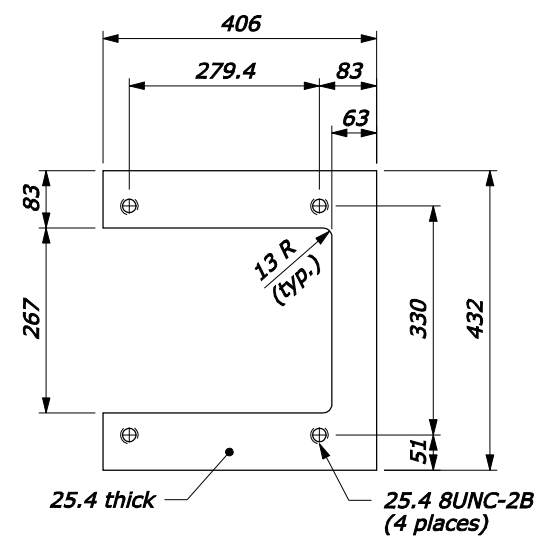

BOTTOM CLAMP PLATE

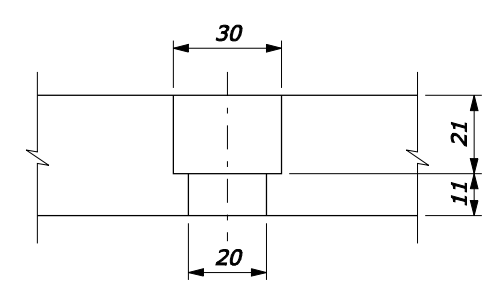

DETAIL A

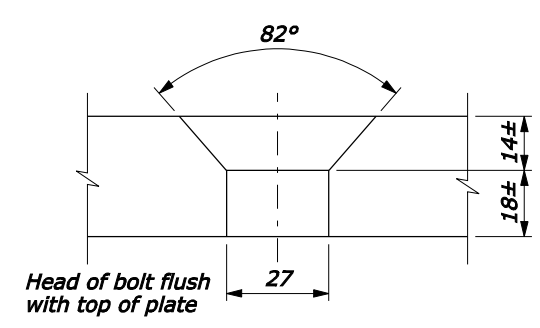

DETAIL B

NO SCALE

U.S. DEPARTMENT OF TRANSPORTATION FEDERAL HIGHWAY ADMINISTRATION WESTERN FEDERAL LANDS HIGHWAY DIVISION	
METRIC DETAIL REMOVABLE STEEL-BACKED LOG RAIL Sheet 3 of 3	
DETAIL APPROVED FOR USE 3/2009	DETAIL WM617-83

2211428-B-Y 1:M 00000000
 fpp://196.145.188.2/exd_plan/wf/w61783.dgn [Metric]