

INSTALLATION BEYOND TOE OF SLOPE

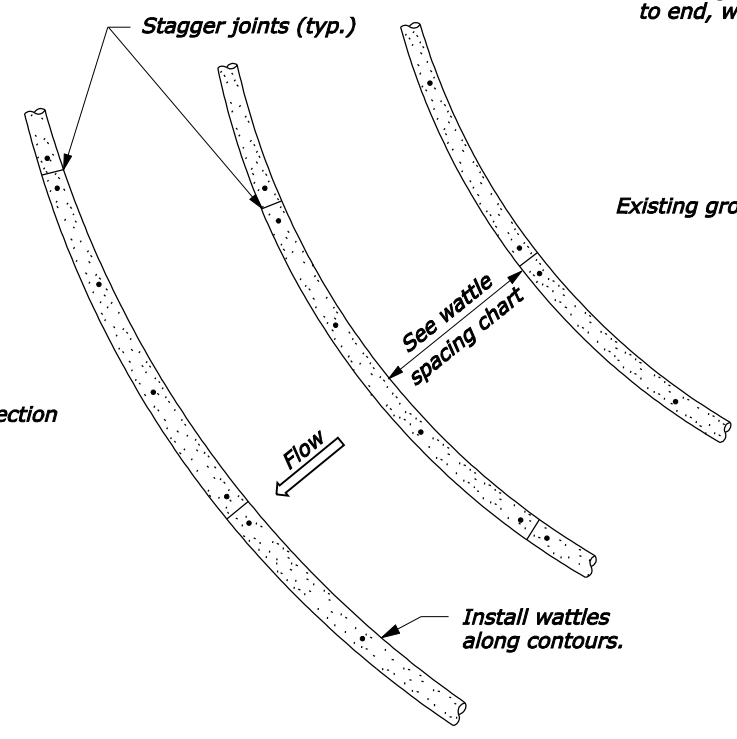

INSTALLATION ALONG SLOPES

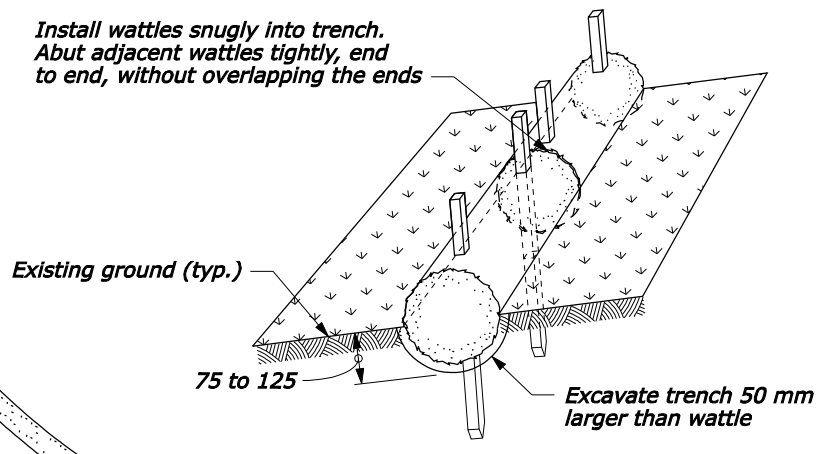

Step 1: Excavate trench and install wattles

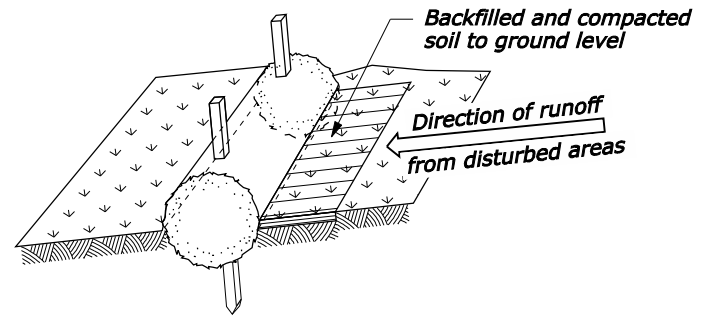

Step 2: Backfill soil against wattles

PROPERLY STAKED AND ENTRENCHED WATTLE

NOTE:

1. Drive stakes at each end and at 1.2 m spacing until wattle is secure to slope. Do not crush wattle while staking. Live stakes may be used for permanent installations.
2. Use drainage ditch installation only in low flow conditions.
3. Dimensions without units are millimeters.

STAKES REQUIRED	
Wattle length (m)	Stakes required for each wattle
7.5	8
6.0	6
3.5	4

WATTLE SPACING	
Slope	Spacing (m)
1:4 or flatter	12
1:3	9
1:2	6
1:1	3

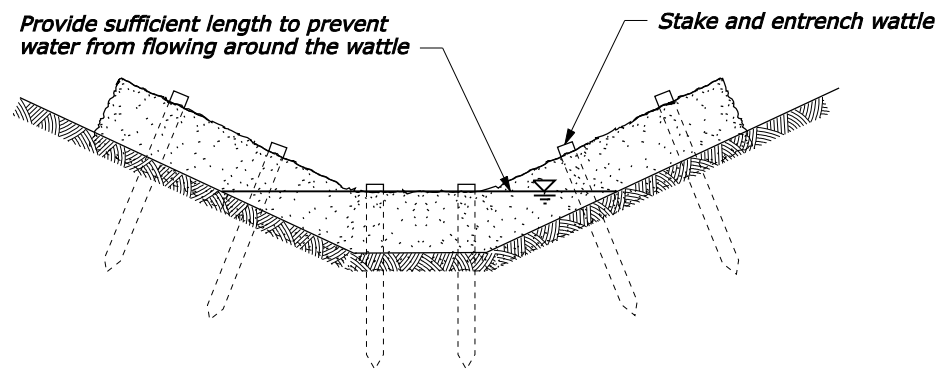

ELEVATION

DRAINAGE DITCH INSTALLATION

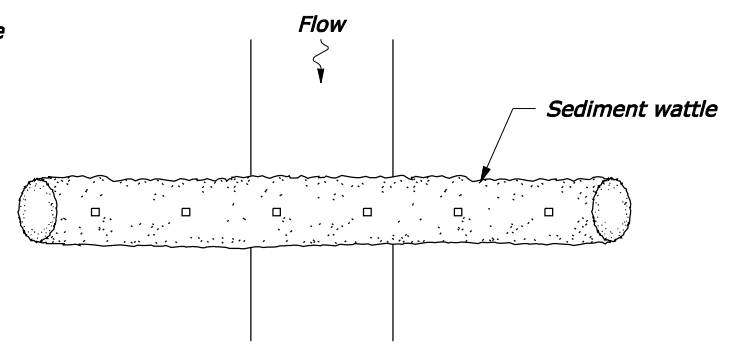

PLAN

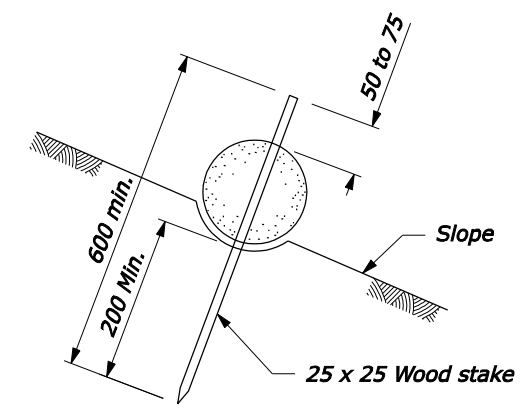

WATTLE STAKING DETAIL

NO SCALE

U.S. DEPARTMENT OF TRANSPORTATION FEDERAL HIGHWAY ADMINISTRATION WESTERN FEDERAL LANDS HIGHWAY DIVISION	
METRIC DETAIL	
SEDIMENT WATTLE	
DETAIL APPROVED FOR USE 9/2007	DETAIL
REVISED:	WM157-20