

Chapter VIII

Biosparging

Contents

Overview	VIII-1
Initial Screening Of Biosparging Effectiveness	VIII-7
Detailed Evaluation Of Biosparging Effectiveness	VIII-9
Site Characteristics That Affect Biosparging	VIII-9
Intrinsic Permeability	VIII-9
Soil Structure And Stratification	VIII-11
Temperature Of The Groundwater	VIII-11
pH Levels	VIII-11
Microbial Population Density	VIII-12
Nutrient Concentrations	VIII-13
Iron Concentration Dissolved In Groundwater	VIII-13
Constituent Characteristics That Affect Biosparging	VIII-14
Chemical Structure	VIII-14
Concentration And Toxicity	VIII-15
Vapor Pressure	VIII-17
Product Composition And Boiling Point	VIII-17
Henry's Law Constant	VIII-18
Laboratory Treatability And Field Pilot Scale Studies	VIII-18
Evaluation Of The Biosparging System Design	VIII-20
Rationale For The Design	VIII-21
Components Of A Biosparging System	VIII-23
Sparge And Extraction Wells	VIII-24
Manifold Piping	VIII-27
Compressed Air Equipment	VIII-28
Monitoring And Controls	VIII-29
Evaluation Of Operation And Monitoring Plans	VIII-30
Startup Operations	VIII-31
Long-Term Operations	VIII-31
Remedial Progress Monitoring	VIII-32
References	VIII-34
Checklist: Can Biosparging Be Used At This Site?	VIII-35

List Of Exhibits

Number	Title	Page
VIII-1	Biosparging System (Used With Soil Vapor Extraction)	VIII-2
VIII-2	Advantages And Disadvantages Of Biosparging	VIII-3
VIII-3	Biosparging Evaluation Process Flow Chart	VIII-4
VIII-4	Initial Screening For Biosparging Effectiveness	VIII-8
VIII-5	Key Parameters Used To Evaluate The Suitability Of Biosparging	VIII-9
VIII-6	Intrinsic Permeability And Biosparging Effectiveness	VIII-10
VIII-7	Heterotrophic Bacteria And Biosparging Effectiveness	VIII-13
VIII-8	Dissolved Iron And Biosparging Effectiveness	VIII-14
VIII-9	Chemical Structure And Biodegradability	VIII-15
VIII-10	Constituent Concentration And Biosparging Effectiveness	VIII-16
VIII-11	Cleanup Concentrations And Biosparging Effectiveness	VIII-16
VIII-12	Vapor Pressures Of Common Petroleum Constituents	VIII-17
VIII-13	Petroleum Product Boiling Ranges	VIII-18
VIII-14	Henry's Law Constant Of Common Petroleum Constituents	VIII-19
VIII-15	Pilot Test Data Objectives	VIII-21
VIII-16	Schematic Of Biosparging System Used With Vapor Extraction	VIII-24
VIII-17	Well Orientation And Site Conditions	VIII-25
VIII-18	Biosparging/Vapor Extraction Well Configurations	VIII-26

List Of Exhibits (cont'd)

Number	Title	Page
VIII-19	Combined Biosparging/Vapor Extraction System Layout	VIII-27
VIII-20	Vertical Sparging Well Construction	VIII-28
VIII-21	Horizontal Sparging Well Construction	VIII-29
VIII-22	Monitoring And Control Equipment	VIII-30
VIII-23	System Monitoring Recommendations	VIII-32
VIII-24	Concentration Reduction And Mass Removal Behavior For Biosparging Systems	VIII-33

Chapter VIII

Biosparging

Overview

Biosparging is an in-situ remediation technology that uses indigenous microorganisms to biodegrade organic constituents in the saturated zone. In biosparging, air (or oxygen) and nutrients (if needed) are injected into the saturated zone to increase the biological activity of the indigenous microorganisms. Biosparging can be used to reduce concentrations of petroleum constituents that are dissolved in groundwater, adsorbed to soil below the water table, and within the capillary fringe. Although constituents adsorbed to soils in the unsaturated zone can also be treated by biosparging, bioventing is typically more effective for this situation. (Chapter III provides a detailed description of bioventing.)

The biosparging process is similar to air sparging. However, while air sparging removes constituents primarily through volatilization, biosparging promotes biodegradation of constituents rather than volatilization (generally by using lower flow rates than are used in air sparging). In practice, some degree of volatilization and biodegradation occurs when either air sparging or biosparging is used. (Air sparging is discussed in Chapter VII.)

When volatile constituents are present, biosparging is often combined with soil vapor extraction or bioventing (collectively referred to as vapor extraction in this chapter), and can also be used with other remedial technologies. When biosparging is combined with vapor extraction, the vapor extraction system creates a negative pressure in the vadose zone through a series of extraction wells that control the vapor plume migration. Chapters II and III provide detailed discussions of soil vapor extraction and bioventing, respectively. Exhibit VIII-1 provides a conceptual drawing of a biosparging system with vapor extraction.

The existing literature contains case histories describing both the successes and failures of biosparging; however, because the technology is relatively new, few cases provide substantial documentation of performance. When used appropriately, biosparging is effective in reducing petroleum products at underground storage tank (UST) sites. Biosparging is most often used at sites with mid-weight petroleum products (e.g., diesel fuel, jet fuel); lighter petroleum products (e.g., gasoline) tend to volatilize readily and to be removed more rapidly using air sparging. Heavier products (e.g., lubricating oils) generally take longer to biodegrade than the lighter products, but biosparging can still be used at these sites. Exhibit VIII-2 provides a summary of the advantages and disadvantages of biosparging.

Exhibit VIII-1
 Biosparging System (Used With Soil Vapor Extraction)

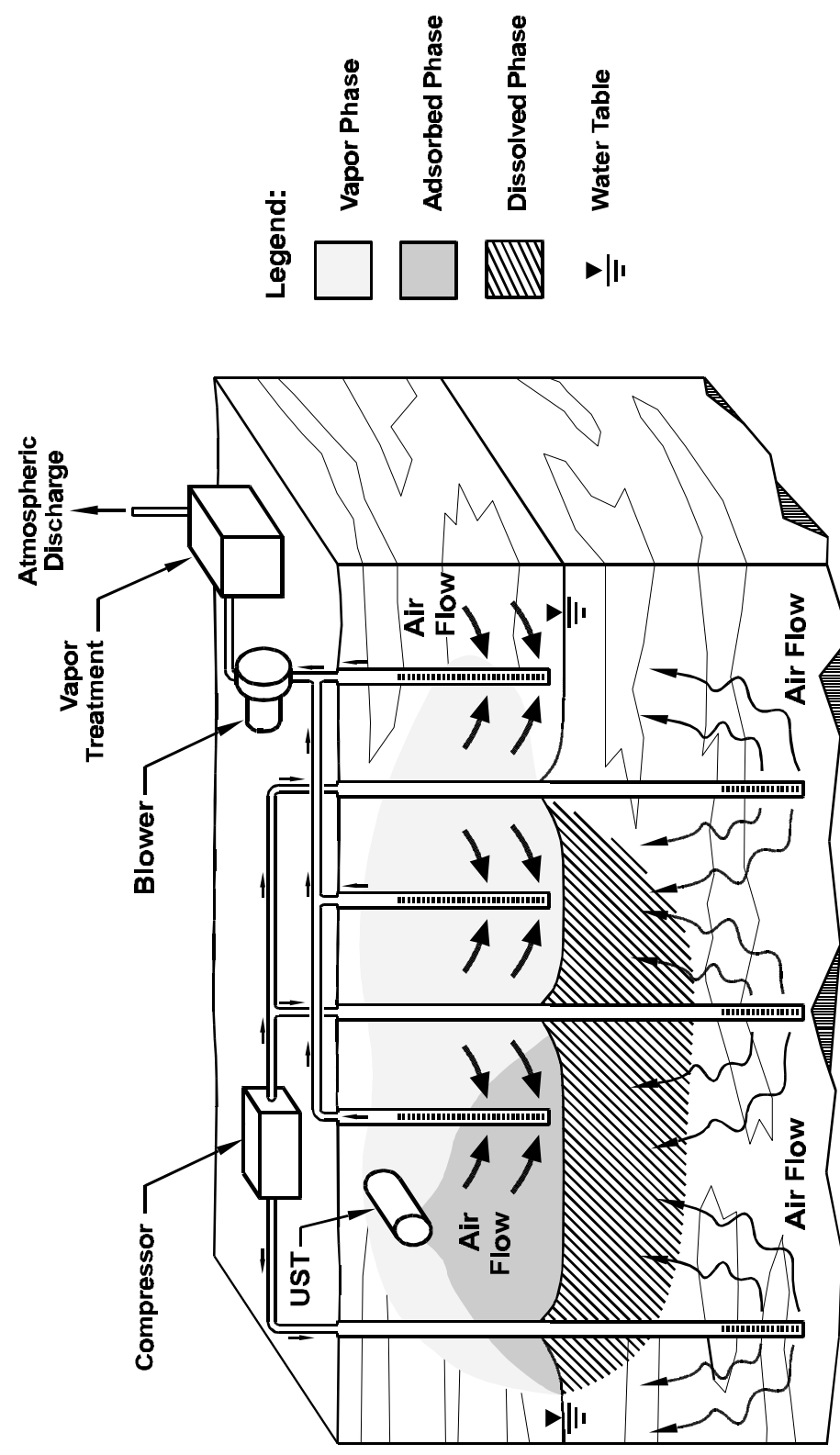

Exhibit VIII-2
Advantages And Disadvantages Of Biosparging

Advantages	Disadvantages
<ul style="list-style-type: none"> ○ Readily available equipment; easy to install. ○ Creates minimal disturbance to site operations. ○ Short treatment times, 6 months to 2 years under favorable conditions. ○ Is cost competitive. ○ Enhances the effectiveness of air sparging for treating a wider range of petroleum hydrocarbons. ○ Requires no removal, treatment, storage, or discharge of groundwater. ○ Low air injection rates minimize potential need for vapor capture and treatment. 	<ul style="list-style-type: none"> ○ Can only be used in environments where air sparging is suitable (e.g., uniform and permeable soils, unconfined aquifer, no free-phase hydrocarbons, no nearby subsurface confined spaces). ○ Some interactions among complex chemical, physical, and biological processes are not well understood. ○ Lack of field and laboratory data to support design considerations. ○ Potential for inducing migration of constituents.

This chapter will assist you in evaluating a corrective action plan (CAP) that proposes biosparging as a remedy for petroleum-contaminated groundwater and soil. The evaluation process is summarized in a flow diagram shown in Exhibit VIII-3, which serves as a roadmap for the decisions you will make during your evaluation. A checklist has also been provided at the end of this chapter for you to use as a tool to both evaluate the completeness of the CAP and to focus attention on areas where additional information may be needed. The evaluation process can be divided into the four steps described below.

- **Step 1: An initial screening of biosparging effectiveness** allows you to quickly gauge whether biosparging is likely to be effective, moderately effective, or ineffective.
- **Step 2: A detailed evaluation of biosparging effectiveness** provides further screening criteria to confirm whether biosparging is likely to be effective. You will need to identify site and constituent characteristics, compare them to ranges where biosparging is effective, and evaluate pilot study plans.

**Exhibit VIII-3
Biosparging Evaluation Process Flow Chart**

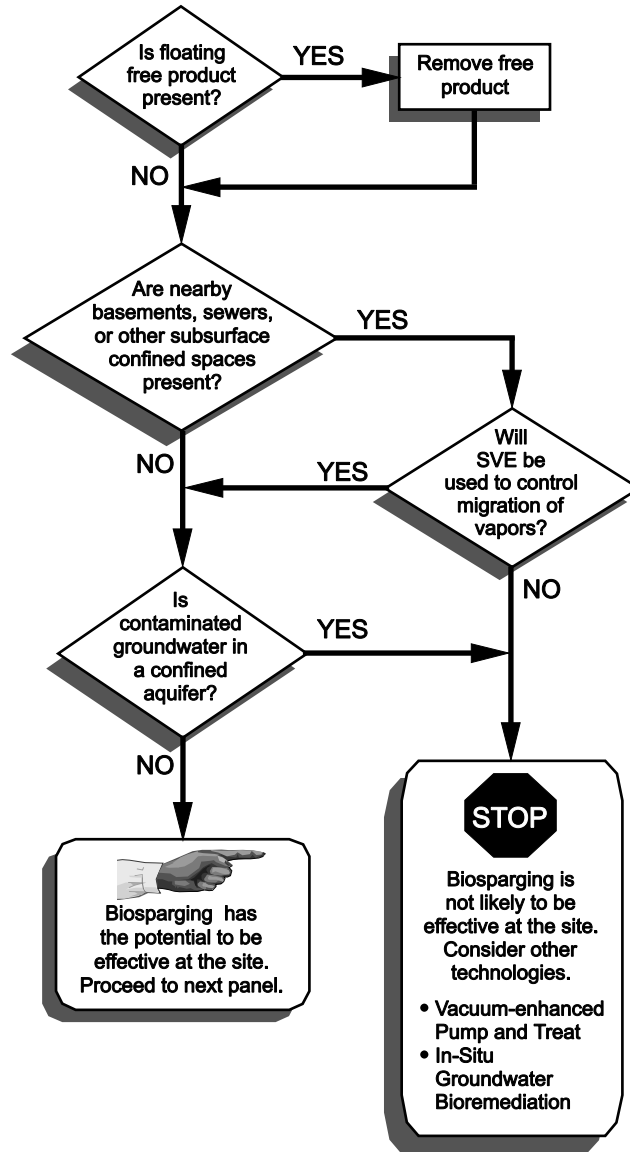
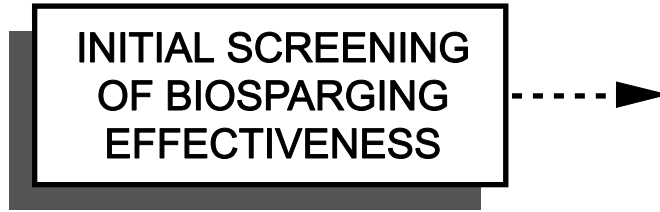

**Exhibit VIII-3
Biosparging Evaluation Process Flow Chart**

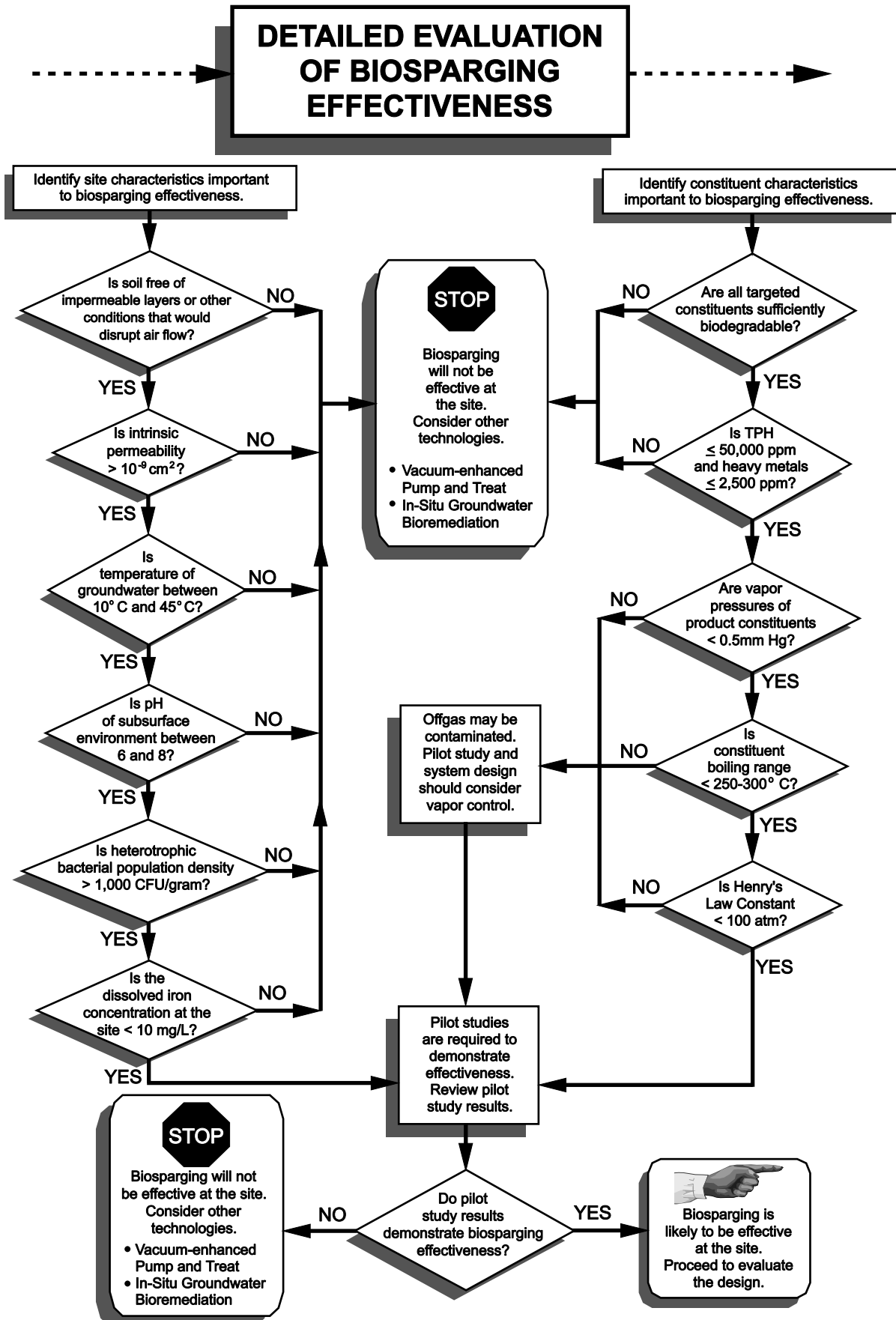

**Exhibit VIII-3
Biosparging Evaluation Process Flow Chart**

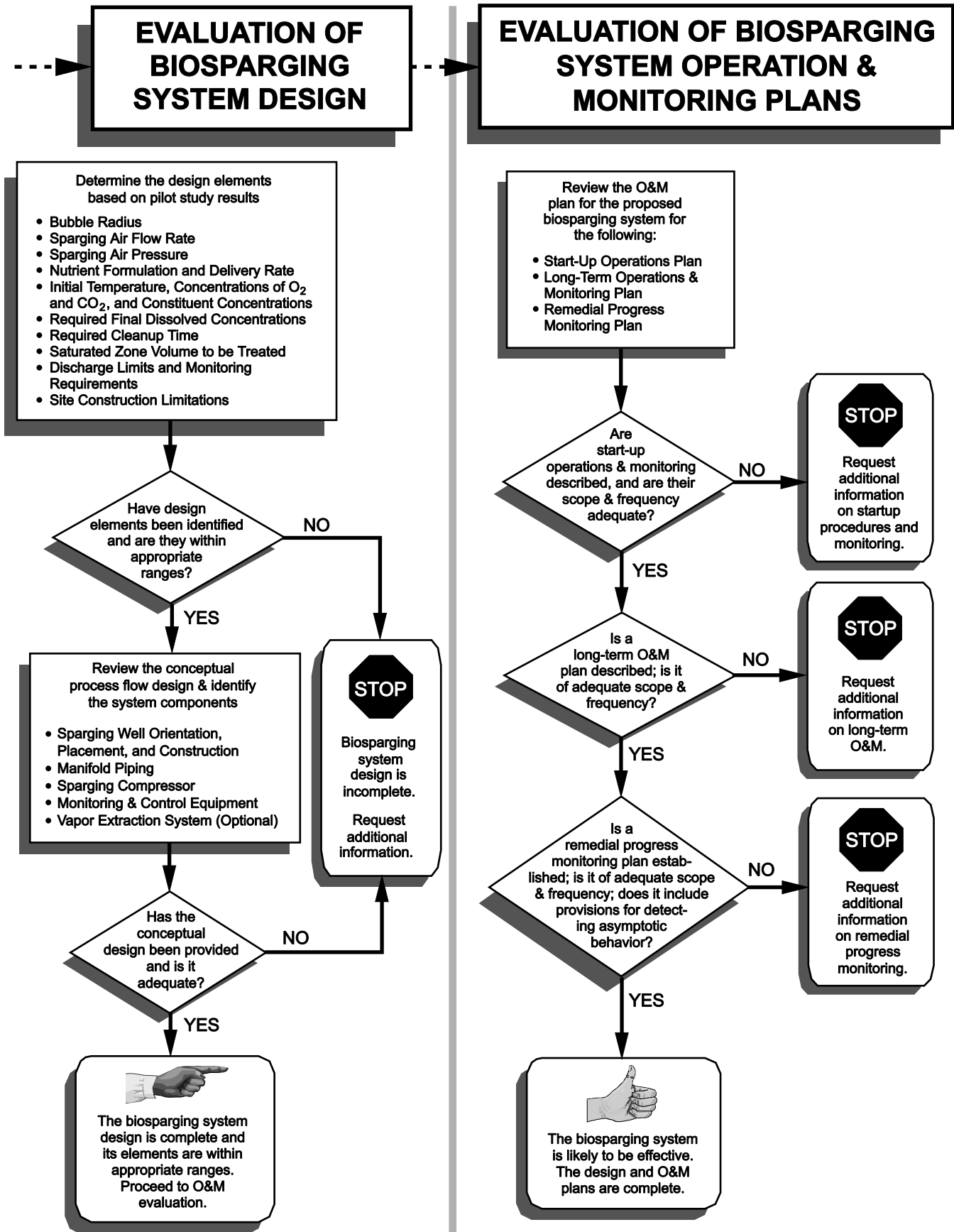

- **Step 3: An evaluation of the biosparging system design** allows you to determine whether basic design information has been defined, whether necessary design components have been specified, whether construction process flow designs are consistent with standard practice, and if a detailed field pilot scale test has been properly performed.
- **Step 4: An evaluation of the operation and monitoring plans** allows you to determine whether start-up and long-term system operation and monitoring is of sufficient scope and frequency and whether remedial progress monitoring plans are appropriate.

Initial Screening Of Biosparging Effectiveness

This section allows you to perform an initial screening of whether biosparging will be effective at a site. First, you need to determine whether or not any site-specific factors which could prohibit the use of biosparging are present. Second, you need to determine if the key parameters which contribute to the effectiveness and design are within appropriate ranges for biosparging.

Biosparging should not be used if the following site conditions exist:

- *Free product is present.* Biosparging can create groundwater mounding which could cause free product to migrate and contamination to spread.
- *Basements, sewers, or other subsurface confined spaces are located near the site.* Potentially dangerous constituent concentrations could accumulate in basements and other subsurface confined spaces unless a vapor extraction system is used to control vapor migration.
- *Contaminated groundwater is located in a confined aquifer system.* Biosparging cannot be used to treat groundwater in a confined aquifer because the air sparged into the aquifer would be trapped by the saturated confining layer and could not escape to the unsaturated zone.

The effectiveness of biosparging depends primarily on two factors:

- The *permeability* of the soil which determines the rate at which oxygen can be supplied to the hydrocarbon-degrading microorganisms in the subsurface.
- The *biodegradability* of the petroleum constituents which determines both the rate at which and the degree to which the constituents will be degraded by microorganisms.

In general, the type of soil will determine its *permeability*. Fine-grained soils (e.g., clays and silts) have lower permeabilities than coarse-grained soils (e.g., sands and gravels). The *biodegradability* of a petroleum constituent is a measure of its ability to be metabolized by hydrocarbon-degrading bacteria or other microorganisms. Petroleum constituents are generally biodegradable, regardless of their molecular weight, as long as indigenous microorganisms have an adequate supply of oxygen and nutrients. For heavier constituents (which are generally less volatile and less soluble than lighter constituents), biodegradation will exceed volatilization as the primary removal mechanism, even though biodegradation is generally slower for heavier constituents than for lighter constituents.

Exhibit VIII-4 is an initial screening tool that you can use to help assess the potential effectiveness of biosparging for a given site. To use this tool, first determine the type of soil present and the type of petroleum product released at the site. Information provided in the following section will allow a more thorough evaluation of effectiveness and will identify areas that could require special design considerations.

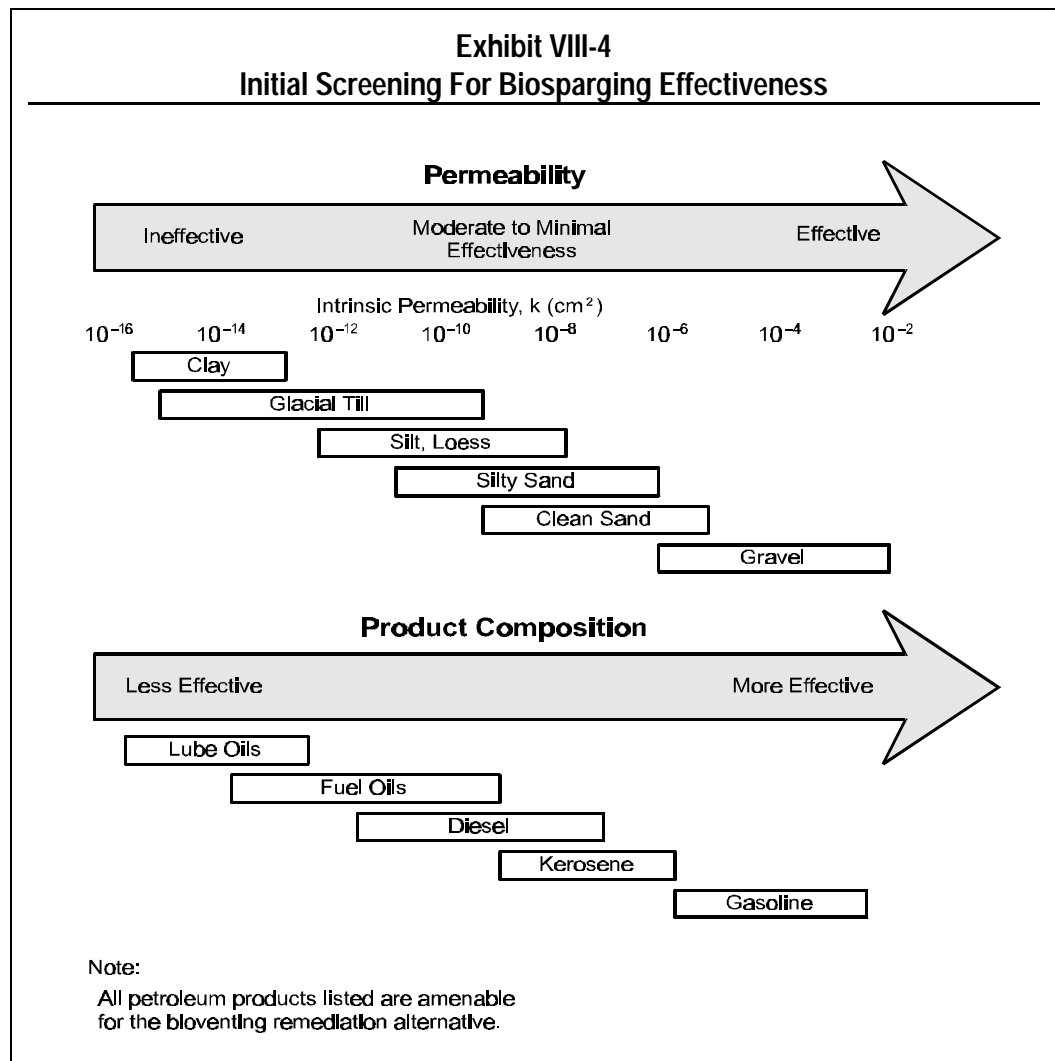

Detailed Evaluation Of Biosparging Effectiveness

Once you have completed the initial screening and determined that biosparging may be effective for the soils and petroleum product present, evaluate the CAP further to confirm that biosparging will be effective.

While the initial screen focused on soil permeability and constituent biodegradability, the detailed evaluation should consider a broader range of site and constituent characteristics, which are listed in Exhibit VIII-5.

Exhibit VIII-5 Key Parameters Used To Evaluate The Suitability Of Biosparging	
Site Characteristics	Constituent Characteristics
Intrinsic permeability	Chemical structure
Soil structure and stratification	Concentration and toxicity
Temperature	Vapor pressure
pH	Product composition and boiling point
Microbial population density	Henry's law constant
Nutrient concentrations	
Dissolved iron concentration	

The remainder of this section describes each parameter, why it is important to biosparging, how it can be determined, and its range for effective biosparging. If a vapor extraction system is considered for vapor control requirements, additional factors such as depth to groundwater and moisture content of the unsaturated zone should be examined to determine if vapor extraction is suitable. See Chapter II: Soil Vapor Extraction for the evaluation of the vapor extraction component, if used.

Site Characteristics That Affect Biosparging

Intrinsic Permeability

Intrinsic permeability is a measure of the ability of soil to transmit fluids and is the *single most important characteristic of the soil* in determining the effectiveness of biosparging because it controls how well oxygen can be delivered to the subsurface microorganisms. Aerobic hydrocarbon-degrading bacteria use oxygen to metabolize organic material to yield carbon dioxide and water. To degrade large amounts of a petroleum product, a substantial bacterial population is required which, in turn, requires oxygen for both metabolic processes and an increase in the overall bacterial population. Approximately 3 to 3½ pounds of oxygen are needed to degrade one pound of petroleum product.

Intrinsic permeability varies over 13 orders of magnitude (from 10^{-16} to 10^{-3} cm²) for the wide range of earth materials, although a more limited range applies to most soil types (10^{-13} to 10^{-5} cm²). Intrinsic permeability of the saturated zone for biosparging is best determined from field tests, but it can also be estimated from soil boring logs and laboratory tests. Procedures for these tests are described in EPA (1991a). Coarse-grained soils (e.g., sands) have greater intrinsic permeability than fine-grained soils (e.g., clays and silts). Use the values shown in Exhibit VIII-6 to determine if the intrinsic permeability of the soils at the site are within the range of effectiveness for biosparging.

Exhibit VIII-6 Intrinsic Permeability And Biosparging Effectiveness	
Intrinsic Permeability (k)(cm ²)	Biosparging Effectiveness
$k > 10^{-9}$	Generally effective.
$10^{-9} \geq k \geq 10^{-10}$	May be effective; needs further evaluation.
$k < 10^{-10}$	Marginal effectiveness to ineffective.

Intrinsic permeability of saturated-zone soils is usually determined in the field by aquifer pump tests that measure hydraulic conductivity. You can convert hydraulic conductivity to intrinsic permeability using the following equation:

$$k = K (\mu/\rho g)$$

where: k = intrinsic permeability (cm²)
 K = hydraulic conductivity (cm/sec)
 μ = water viscosity (g/cm · sec)
 ρ = water density (g/cm³)
 g = acceleration due to gravity (cm/sec²)

$$\text{At } 20^\circ\text{C: } \mu/\rho g = 1.02 \cdot 10^{-5} \text{ cm/sec}$$

Convert k from cm² to darcy, multiply by 10^8 .

Intrinsic permeability of the unsaturated zone can be estimated from the intrinsic permeability of the saturated zone if similar soil types are present. Alternatively, it can be determined in the field by conducting permeability tests or soil vapor extraction pilot studies. (See Chapter II: Soil Vapor Extraction.)

Soil Structure And Stratification

The types of soil present and their micro- and macro-structures will control the biosparging pressure and distribution of oxygen and nutrients in the saturated zone. For example, fine-grained soils require higher sparging air pressures because air flow is restricted through smaller pores, thereby reducing the efficiency of oxygen distribution. In general, air injection rates used in biosparging are low enough that vapor migration is not a major concern. However, this rate must be assessed on a site-by-site basis.

Soil characteristics also determine the preferred zones of vapor flow in the unsaturated zone, thereby indicating the ease with which vapors can be controlled and extracted (if vapor extraction is used). Stratified or highly variable heterogeneous soils typically create the greatest impediments to biosparging. Both the injected air and the stripped vapors will travel along the paths of least resistance (coarse-grained zones) and could travel a great lateral distance from the injection point. This phenomenon could result in enhanced migration of constituents.

Information about soil type, structure, and stratification can be determined from boring logs or geologic cross-section maps. You should verify that soil types have been identified and that visual observations of soil structure have been documented.

Temperature Of The Groundwater

Bacterial growth rate is a function of temperature. Subsurface microbial activity has been shown to decrease significantly at temperatures below 10°C and essentially to cease below 5°C. Microbial activity of most bacterial species important to petroleum hydrocarbon biodegradation also diminishes at temperatures greater than 45°C. Within the range of 10°C to 45°C, the rate of microbial activity typically doubles for every 10°C rise in temperature. In most cases, because biosparging is an in-situ technology, the bacteria are likely to experience stable groundwater temperatures with only slight seasonal variations. In most areas of the U.S., the average groundwater temperature is about 13°C, but groundwater temperatures may be somewhat lower or higher in the extreme northern and southern states.

pH Levels

The optimum pH for bacterial growth is approximately 7; the acceptable range for biosparging is between 6 and 8. If the groundwater pH is outside of this range, it is possible to adjust the pH prior to and during biosparging operations. However, pH adjustment is often not cost-effective because natural buffering capacity of the groundwater system generally necessitates continuous adjustment and monitoring throughout the biosparging operation. In addition, efforts to adjust pH

may lead to rapid changes in pH, which are also detrimental to bacterial activity.

Microbial Population Density

Soil normally contains large numbers of diverse microorganisms including bacteria, algae, fungi, protozoa, and actinomycetes. Of these organisms, the bacteria are the most numerous and biochemically active group, particularly at low oxygen levels. Bacteria require a carbon source for cell growth and an energy source to sustain metabolic functions required for growth. Nutrients, including nitrogen and phosphorus, are also required for cell growth. The metabolic process used by bacteria to produce energy requires a terminal electron acceptor (TEA) to enzymatically oxidize the carbon source to carbon dioxide.

Microbes are classified by the carbon and TEA sources they use to carry out metabolic processes. Bacteria that use organic compounds (such as petroleum constituents and other naturally occurring organics) as their source of carbon are *heterotrophic*; those that use inorganic carbon compounds such as carbon dioxide are *autotrophic*. Bacteria that use oxygen as their TEA are *aerobic*; those that use a compound other than oxygen (e.g., nitrate or sulfate) are *anaerobic*; and those that can utilize both oxygen and other compounds as TEAs are *facultative*. For biosparging applications directed at petroleum products, bacteria that are both *aerobic* (or *facultative*) and *heterotrophic* are most important in the degradation process.

To evaluate the presence and population density of naturally occurring bacteria that will contribute to degradation of petroleum constituents, laboratory analysis of soil samples from the site (collected from below the water table) should be conducted. These analyses, at a minimum, should include plate counts for total heterotrophic bacteria. Plate count results are normally reported in terms of colony-forming units (CFUs) per gram of soil. Microbial population densities in typical soils range from 10^4 to 10^7 CFU/gram of soil. For biosparging to be effective, the minimum heterotrophic plate count should be 10^3 CFU/gram or greater. Plate counts lower than 10^3 could indicate the presence of toxic concentrations of organic or inorganic (e.g., metals) compounds. These conditions are summarized in Exhibit VIII-7.

Even when plate counts are lower than 10^3 , biosparging may still be effective if the soil is conditioned or amended to reduce the toxic concentrations and increase the microbial population density. More elaborate laboratory tests are sometimes conducted to identify the bacterial species present. Such tests may be desirable if you are uncertain whether or not microbes capable of degrading specific petroleum hydrocarbons occur naturally in the soil. If insufficient numbers or types of microorganisms are present, the population density may be increased by introducing cultured microbes that are available from numerous vendors. These conditions are summarized in Exhibit VIII-7.

Exhibit VIII-7
Heterotrophic Bacteria And Biosparging Effectiveness

Total Heterotrophic Bacteria (prior to biosparging)	Biosparging Effectiveness
> 1,000 CFU/gram dry soil	Generally effective.
< 1,000 CFU/gram dry soil	May be effective; needs further evaluation to determine if toxic conditions are present.

Nutrient Concentrations

Bacteria require inorganic nutrients such as nitrogen and phosphate to support cell growth and sustain biodegradation processes. Nutrients may be available in sufficient quantities in the aquifer but, more frequently, nutrients need to be added to maintain adequate bacterial populations. However, excessive amounts of certain nutrients (i.e., phosphate and sulfate) can repress metabolism.

A rough approximation of minimum nutrient requirements can be based on the stoichiometry of the overall biodegradation process:

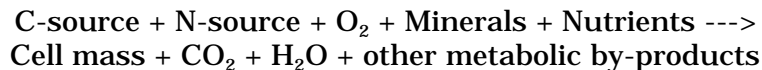

Different empirical formulas of bacterial cell mass have been proposed; the most widely accepted are $\text{C}_5\text{H}_7\text{O}_2\text{N}$ and $\text{C}_{60}\text{H}_{87}\text{O}_{32}\text{N}_{12}\text{P}$. Using the empirical formulas for cell biomass and other assumptions, the carbon:nitrogen:phosphorus ratios necessary to enhance biodegradation fall in the range of 100:10:1 to 100:1:0.5, depending on the constituents and bacteria involved in the biodegradation process.

Chemical analyses of soil samples from the site (collected from below the water table) should be completed to determine the available concentrations of nitrogen (expressed as ammonia) and phosphate that are naturally in the soil. These types of analyses are routinely conducted in agronomic laboratories that test soil fertility for farmers. Using the stoichiometric ratios, the need for nutrient addition can be determined by using an average concentration of the constituents (carbon source) in the soils to be treated. If nitrogen addition is necessary, slow release sources should be used. Nitrogen addition can lower pH, depending on the amount and type of nitrogen added.

Iron Concentration Dissolved In Groundwater

The presence of dissolved ferrous iron (Fe^{+2}) in groundwater can reduce the permeability of the saturated zone soils during the sparging operations. When dissolved iron is exposed to oxygen, it is oxidized to ferric iron (Fe^{+3}) oxide which, because it is less soluble than ferrous iron,

can precipitate within the saturated zone and occlude soil pore space. On a large scale this could reduce the region available for air (and groundwater) flow, thereby reducing permeability. Precipitation of iron oxide occurs predominantly in the saturated zone near sparging well screens where oxygen content (from injected air) is the highest. This oxidation can render sparging wells useless after even short periods of operation; installation of new wells in different locations would then be required.

Verify that laboratory measurements of total dissolved iron have been completed for groundwater samples from the site. Use Exhibit VIII-8 to determine the range in which dissolved iron is a concern for biosparging effectiveness.

Exhibit VIII-8	
Dissolved Iron And Biosparging Effectiveness	
<u>Dissolved Iron Concentration (mg/L)</u>	<u>Biosparging Effectiveness</u>
$Fe^{+2} < 10$	Biosparging effective.
$10 \leq Fe^{+2} \leq 20$	Sparging wells require periodic testing and may need periodic replacement.
$Fe^{+2} > 20$	Biosparging not recommended.

Constituent Characteristics That Affect Biosparging

Chemical Structure

The chemical structures of the constituents to be treated by biosparging are important for determining the rate at which biodegradation will occur. Although nearly all constituents in petroleum products typically found at UST sites are biodegradable, the more complex the molecular structure of the constituent, the more difficult and less rapid is biological treatment. Most low-molecular-weight (nine carbon atoms or less) aliphatic and monoaromatic constituents are more easily biodegraded than higher-molecular-weight aliphatic or polyaromatic organic constituents. Exhibit VIII-9 lists, in order of decreasing rate of potential biodegradability, some common constituents found at petroleum UST sites.

Evaluation of the chemical structure of the constituents proposed for reduction by biosparging at the site will allow you to determine which constituents will be the most difficult to degrade. You should verify that remedial time estimates, biotreatability studies, field-pilot studies (if applicable), and biosparging operation and monitoring plans are based on the constituents that are the most difficult to degrade (or “rate limiting”) in the biodegradation process.

**Exhibit VIII-9
Chemical Structure And Biodegradability**

Biodegradability	Example Constituents	Products In Which Constituent Is Typically Found
More degradable  Less degradable	n-butane, l-pentane, n-octane Nonane	<input type="radio"/> Gasoline <input type="radio"/> Diesel fuel
	Methyl butane, dimethylpentenes, methyloctanes	<input type="radio"/> Gasoline
	Benzene, toluene, ethylbenzene, xylenes Propylbenzenes	<input type="radio"/> Gasoline <input type="radio"/> Diesel, kerosene
	Decanes Dodecanes Tridecanes Tetradecanes	<input type="radio"/> Diesel <input type="radio"/> Kerosene <input type="radio"/> Heating fuels <input type="radio"/> Lubricating oils
	Naphthalenes Fluoranthenes Pyrenes Acenaphthenes	<input type="radio"/> Diesel <input type="radio"/> Kerosene <input type="radio"/> Heating oil <input type="radio"/> Lubricating oils

Concentration And Toxicity

The presence of very high concentrations of petroleum organics or heavy metals in site soils can be toxic or inhibit the growth and reproduction of bacteria responsible for biodegradation. In addition, very low concentrations of organic material will also result in diminished levels of bacterial activity.

In general, concentrations of petroleum hydrocarbons in excess of 50,000 ppm, or heavy metals in excess of 2,500 ppm, in soils are considered inhibitory and/or toxic to aerobic bacteria. Review the CAP to verify that the average concentrations of petroleum hydrocarbons and heavy metals in the soils and groundwater to be treated are below these levels. Exhibit VIII-10 provides the general criteria for constituent concentration and bioparging effectiveness.

In addition to maximum concentrations, you should consider the cleanup concentrations proposed for the treated soils. Below a certain "threshold" constituent concentration, the bacteria cannot obtain sufficient carbon (from degradation of the constituents) to maintain adequate biological activity. The threshold level can be determined from

Exhibit VIII-10	
Constituent Concentration And Biosparging Effectiveness	
Constituent Concentration	Biosparging Effectiveness
Petroleum constituents \leq 50,000 ppm and Heavy metals \leq 2,500 ppm	Effective.
Petroleum constituents $>$ 50,000 ppm or Heavy metals $>$ 2,500 ppm	Ineffective; toxic or inhibitory conditions to bacterial growth exist. Long remediation times likely.

laboratory studies and should be below the level required for cleanup. Although the threshold limit varies greatly depending on bacteria-specific and constituent-specific features, constituent concentrations below 0.1 ppm are generally not achievable by biological treatment alone. In addition, experience has shown that reductions in total petroleum hydrocarbon concentrations (TPH) greater than 95 percent can be very difficult to achieve because of the presence of "recalcitrant" or nondegradable petroleum hydrocarbons that are included in the TPH analysis. Identify the average starting concentrations and the cleanup concentrations in the CAP for individual constituents and TPH. If a cleanup level lower than 0.1 ppm is required for any individual constituent or a reduction in TPH greater than 95 percent is required to reach the cleanup level for TPH, either a pilot study should be required to demonstrate the ability of biosparging to achieve these reductions at the site or another technology should be considered. These conditions are summarized in Exhibit VIII-11.

Exhibit VIII-11	
Cleanup Concentrations And Biosparging Effectiveness	
Cleanup Requirement	Biosparging Effectiveness
Constituent concentration $>$ 0.1 ppm and TPH reduction $<$ 95%	Effective.
Constituent concentration \leq 0.1 ppm or TPH reduction \geq 95%	Potentially ineffective; pilot studies are required to demonstrate reductions.

Vapor Pressure

Vapor pressure is important in evaluating the extent to which constituents will be volatilized rather than biodegraded. The vapor pressure of a constituent is a measure of its tendency to evaporate. More precisely, it is the pressure that a vapor exerts when in equilibrium with its pure liquid or solid form. Constituents with higher vapor pressures are generally volatilized rather than biodegraded. In general, constituents with vapor pressures higher than 0.5 mm Hg will likely be volatilized by the induced air stream before they biodegrade. Constituents with vapor pressures lower than 0.5 mm Hg will not volatilize to a significant degree and can instead undergo *in situ* biodegradation by bacteria.

As previously discussed, petroleum products contain many different chemical constituents. Each constituent will be volatilized (rather than biodegraded) to different degrees by a biosparging system, depending on its vapor pressure. If concentrations of volatile constituents are significant, use of a vapor extraction system and treatment of extracted vapors may be needed. Exhibit VIII-12 lists vapor pressures of select petroleum constituents.

Constituent	Vapor Pressure (mm Hg at 20°C)
Methyl t-butyl ether	245
Benzene	76
Toluene	22
Ethylene dibromide	11
Ethylbenzene	7
Xylenes	6
Naphthalene	0.5
Tetraethyl lead	0.2

Product Composition And Boiling Point

Boiling point is another measure of constituent volatility. Because of their complex constituent compositions, petroleum products are often classified by their boiling point ranges (rather than vapor pressures). In general, nearly all petroleum-derived organic compounds are capable of biological degradation, although constituents of higher molecular weights and higher boiling points require longer periods of time to be degraded. Products with boiling points of less than about 250°C to 300°C will volatilize to some extent and can be removed by a

combination of volatilization and biodegradation in a biosparging system. The boiling point ranges for common petroleum products are shown in Exhibit VIII-13.

Exhibit VIII-13 Petroleum Product Boiling Ranges	
Product	Boiling Range (°C)
Gasoline	40 to 225
Kerosene	180 to 300
Diesel fuel	200 to 338
Heating oil	> 275
Lubricating oils	Nonvolatile

Henry's Law Constant

Another method of gauging the volatility of a constituent is by noting its Henry's law constant, which quantifies the relative tendency of a dissolved constituent to transfer to the vapor phase. Henry's law states that, for ideal gases and solutions under equilibrium conditions, the ratio of the partial pressure of a constituent in the vapor phase to the concentration in the dissolved phase is constant. That is:

$$P_a = H_a X_a$$

where: P_a = partial pressure of constituent a in air
 H_a = Henry's law constant (atm)
 X_a = solution concentration of constituent a (mole fraction)

Henry's law constants for several common constituents found in petroleum products are shown in Exhibit VIII-14. Constituents with Henry's law constants of greater than 100 atmospheres are generally considered volatile and, hence, more likely to be volatilized rather than biodegraded.

Laboratory Treatability And Field Pilot Scale Studies

In general, remedial approaches that rely on biological processes should be subjected to laboratory treatability tests and field pilot studies to verify and quantify the potential effectiveness of the approach and provide data necessary to design the system. However, field tests of biosparging should never be conducted if free product is known to exist at the water table, if uncontrolled vapors could migrate into nearby confined spaces (e.g., sewers, basements) or if the contaminated

Exhibit VIII-14
Henry's Law Constant Of Common Petroleum Constituents

Constituent	Henry's Law Constant (atm)
Tetraethyl lead	4,700
Ethylbenzene	359
Xylenes	266
Benzene	230
Toluene	217
Naphthalene	72
Ethylene dibromide	34
Methyl t-butyl ether	27

groundwater is in a confined aquifer. The scope of laboratory studies or pilot testing should be commensurate with the size of the area to be treated, the reduction in constituent concentrations required, and the results of the initial effectiveness screening.

Some commonly used laboratory and pilot-scale studies are described below.

- *Laboratory Microbial Screening* tests are used to determine the presence of a population of naturally occurring bacteria that may be capable of degrading petroleum product constituents. Samples of soils from the aquifer are analyzed in an offsite laboratory. Microbial plate counts determine the number of colony forming units (CFU) of heterotrophic bacteria and petroleum-degrading bacteria present per unit mass of dry soil. These tests are relatively inexpensive.
- *Laboratory Biodegradation Studies* can be used to estimate the rate of oxygen delivery and to determine if the addition of inorganic nutrients is necessary. However, laboratory studies cannot duplicate field conditions, and field tests are more reliable. A common biodegradation study for biosparging is the slurry study. Slurry studies involve the preparation of numerous "soil microcosms" consisting of small samples of site soils from the aquifer mixed into a slurry with the site groundwater. The microcosms are divided into several groups which may include control groups which are sterilized to destroy any bacteria, non-nutriented test groups which have been provided oxygen but not nutrients, and nutrient test groups which are supplied both oxygen and nutrients. Microcosms from each group are analyzed periodically (usually weekly) during the test period (usually 4 to 12 weeks) for bacterial population counts and constituent concentrations. Results of slurry studies should be

considered as representing optimal conditions because slurry microcosms do not consider the effects of limited oxygen delivery or soil heterogeneity.

- *Field Biosparging Treatability Tests* determine the effectiveness of biosparging by characterizing the rate of biodegradation, the “bubble” radius, and the potential for plume migration. Data collected from the studies are used to specify design parameters such as the number and density of the wells and the sparging rate. The study usually includes sparging a single well while its effects are being measured in monitoring wells or probes spaced at various distances. Ideally, three or more monitoring wells surrounding the plume should be installed. These monitoring wells should be screened above the saturated zone and through the dissolved phase plume. They can be used to monitor both dissolved and vapor phase migration, to monitor changes in dissolved oxygen, and to measure changes in the depth to groundwater.

If vapor extraction is to be included in the design, the pilot study should be accomplished in two parts. The first portion of the test should be conducted using vapor extraction only and evaluated as described in Chapter II (Soil Vapor Extraction) without the biosparging system being operated. This portion of the pilot test will establish the baseline vapor extraction levels, the extent of the non-sparged vapor plume, the extraction well radius of influence and intrinsic permeability of the unsaturated zone (discussed in Chapter II). The second portion of the study would involve the installation of a sparge point with several vapor extraction points in the vadose zone. Exhibit VIII-15 summarizes the parameters and data that would be useful in a biosparging pilot study.

Evaluation Of The Biosparging System Design

Once you have verified that biosparging has the potential for effectiveness at your site, you can evaluate the design of the system. The CAP should include a discussion of the rationale for the system design and the results of the pilot test(s). Detailed engineering design documents might also be included, depending on individual state requirements. Further detail about information to look for in the discussion of the biosparging design is provided at the end of this chapter. Discussion of the vapor extraction portion of the design is included in Chapter II: Soil Vapor Extraction.

**Exhibit VIII-15
Pilot Test Data Objectives**

Data Requirement	Source
Vapor Extraction Test Portion (if necessary)	
Extraction well radius of influence (ROI)	Monitoring point pressure gauges
Wellhead and monitoring point vacuum	Well-head pressure gauge
Initial contaminant vapor and CO ₂ concentrations	Vapor extraction exhaust flame ionization detector (FID) readings and CO ₂ probe (or other suitable detection device)
Initial hydraulic gradient	Water level tape at monitoring wells or pressure transducers and data logger
Biosparging Test Portion	
Air sparging bubble radius	Monitoring point pressure gauge
Sparging rate	Compressor discharge flow gauge
Sparging vapor concentrations	Monitoring well and vapor point FID readings (or other suitable detection device)
CO ₂ level in the exhaust vapors	Carbon dioxide probe
Hydraulic gradient influence	Water level tape at monitoring wells or pressure transducers and data logger
Dissolved oxygen and carbon dioxide	Dissolved oxygen and carbon dioxide probes at monitoring wells
Combined Test (if necessary)	
Sparging/SVE capture rates	Pressure/flow gauges
Contaminant vapor concentrations	Blower discharge and monitoring points

Rationale For The Design

The following factors should be considered as you evaluate the design of the biosparging system in the CAP.

- **Bubble radius** for sparging wells. The bubble radius should be considered in the design of the biosparging system. The bubble radius is defined as the greatest distance from a sparging well at which sufficient sparge pressure and airflow can be induced to enhance the biodegradation of contaminants. The bubble radius will determine the number and spacing of the sparging wells.

The bubble radius should be determined based on the results of pilot tests. One should be careful, however, when evaluating pilot test results. The measurement of air flow, increased dissolved oxygen, or the presence of air bubbles in a monitoring point can be falsely

interpreted as an air flow zone that is thoroughly permeated with injected air when these observations actually represent localized sparging around sparsely distributed air flow channels. The bubble radius depends primarily on the hydraulic conductivity of the aquifer material in which sparging takes place. Other factors that affect the bubble radius include soil heterogeneities and differences between lateral and vertical permeability of the soils. Generally, the design bubble radius can range from 5 feet for fine-grained soils to 100 feet for coarse-grained soils.

- *Sparging Air Flow Rate.* The sparging air flow rate required to provide sufficient air flow to enhance biological activity is site specific and will be determined via the pilot test. Typical air flow rates are much lower than for air sparging, ranging from 3 to 25 standard cubic feet per minute (scfm) per injection well. Pulsing of the air flow (i.e., turning the system on and off at specified intervals) may provide better distribution and mixing of the air in the contaminated saturated zone, thereby allowing for greater contact with the dissolved phase contaminants. If a vapor extraction system is used, it should have a greater flow capacity and greater area of influence than the biosparging system. Typically the SVE extraction rates range from 1.25 to 5 times greater than the biosparging rate.
- *Sparging Air Pressure* is the pressure at which air is injected below the water table. Injection of air below the water table requires pressure greater than the static water pressure (1 psig for every 2.3 ft of hydraulic head) and the head necessary to overcome capillary forces of the water in the soil pores near the injection point. A typical system will be operated at approximately 10 to 15 psig. Excessive pressure may cause fracturing of the soils and create permanent air channels that can significantly reduce biosparging effectiveness.
- *Nutrient Formulation and Delivery Rate* (if needed) will be based on the results of the laboratory tests and pilot study results. Common nutrient additions include nitrogen (in an aqueous solution containing ammonium ions) and phosphorus (in an aqueous solution containing phosphate ions). Note that state regulations may either require permits for nutrient injection or prohibit them entirely.
- *Initial Constituent Concentrations* will be measured during pilot-scale studies. They establish a baseline for estimating the constituent mass removal rate and the system operation time requirements. In addition, they will help to determine whether vapor treatment will be required.
- *Initial Concentrations of Oxygen and CO₂* in the saturated zone will be measured during pilot studies. They are used to establish system operating requirements, to provide baseline levels of subsurface biological activity, and to allow measurement of the system's progress.

- *Required Final Dissolved Constituent Concentrations* in the saturated zone are either defined by state regulations as “remedial action levels” or determined on a site-specific basis using transport models and risk assessment calculations. They will determine which areas of the site require treatment and when biosparging system operations can be terminated.
- *Required Remedial Cleanup Time* may influence the design of the system. The designer may vary the spacing of the sparging wells to speed remediation to meet cleanup deadlines, if required.
- *Saturated Zone Volume To Be Treated* is determined by state action levels or a site-specific risk assessment using site characterization data for the groundwater.
- *Discharge Limitations and Monitoring Requirements* are usually established by state regulations but must be considered by system designers to ensure that monitoring ports are included in the system. Discharge limitations imposed by state air quality regulations will determine whether offgas treatment is required.
- *Site Construction Limitations* (e.g., building locations, utilities, buried objects, residences) must be identified and considered in the design process.

Components Of A Biosparging System

Once the design rationale is defined, the design of the biosparging system can be developed. A typical biosparging system design includes the following components and information:

- Sparging well orientation, placement, and construction details
- Manifold piping
- Compressed air equipment
- Monitoring and control equipment

A nutrient delivery system is sometimes included in biosparging design. If nutrients are added, the design should specify the type of nutrient addition and the construction details. Note that state regulations may either require permits for nutrient injection wells or prohibit them entirely.

If an SVE system is used for vapor control, the following components and information will also be needed:

- Vapor pretreatment design
- Vapor treatment system selection
- Blower specification

Exhibit VIII-16 provides a schematic diagram of a typical biosparging system used with vapor extraction. Chapter II: Soil Vapor Extraction, should be consulted for information on the design of the vapor extraction portion of the remedial system (if necessary), including vapor pretreatment design, vapor treatment system selection, and blower specification.

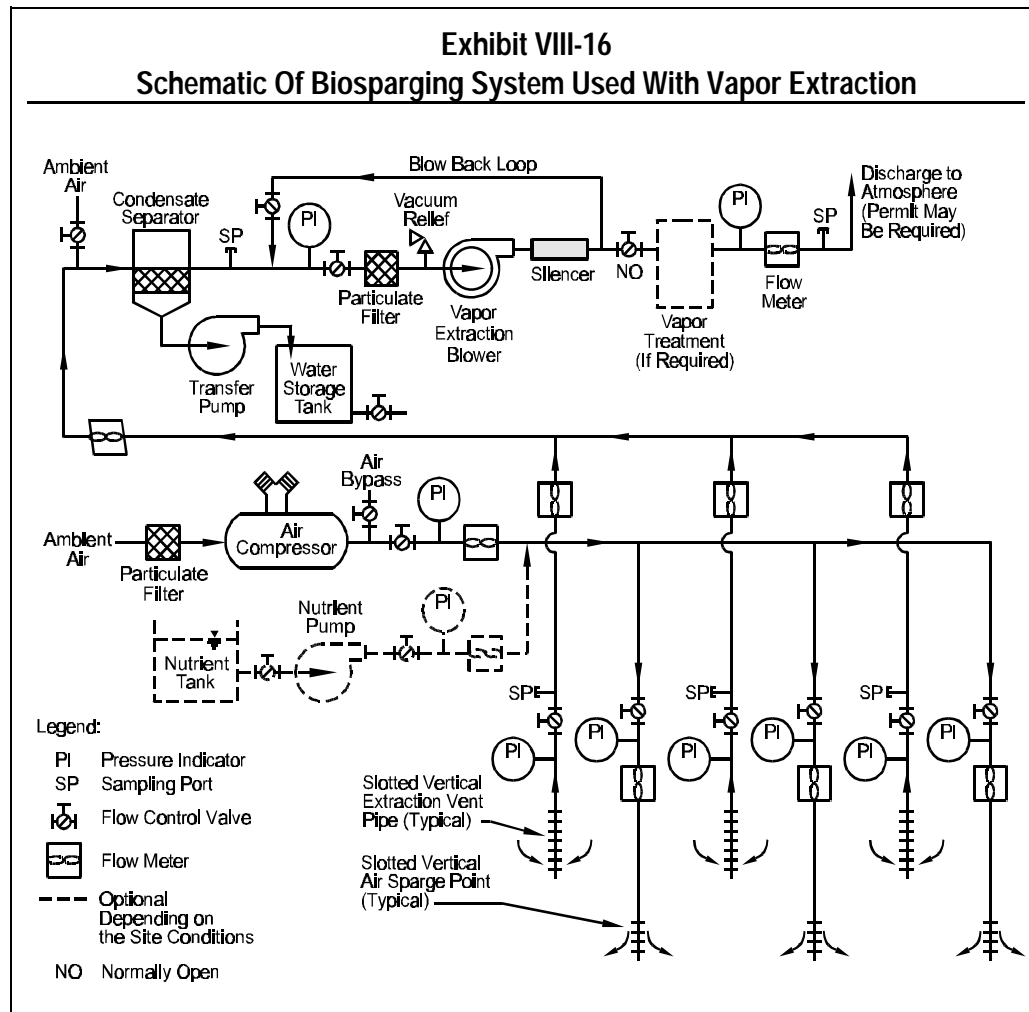

Sparge And Extraction Wells

Well Orientation. A biosparging system can use either vertical or horizontal sparge wells. Well orientation should be based on site-specific needs and conditions. For example, horizontal systems should be considered when evaluating sites that will require 10 or more sparge or extraction points, if the affected area is located under a surface structure, or if the thickness of the saturated zone is less than 10 feet. Exhibit VIII-17 lists site conditions and the corresponding appropriate well orientation.

Exhibit VIII-17
Well Orientation And Site Conditions

Well Orientation	Site Conditions
Vertical wells	<ul style="list-style-type: none"> <input type="radio"/> Deep contamination (> 25 feet) <input type="radio"/> Depth to groundwater (> 10 feet) <input type="radio"/> Fewer than 10 wells <input type="radio"/> Thickness of saturated zone (> 10 feet)
Horizontal wells	<ul style="list-style-type: none"> <input type="radio"/> Shallow groundwater table (< 25 feet) <input type="radio"/> Zone of contamination within a specific stratigraphic unit <input type="radio"/> System under an operational facility <input type="radio"/> Thickness of saturated zone (< 10 feet)

Well Placement And Number of Wells. Exhibit VIII-18, **Biosparging/Vapor Extraction Well Configurations**, shows various configurations that can be used in laying out biosparging systems used in conjunction with vapor extraction. The essential goals in configuring the wells and monitoring points are (1) to optimize the influence on the plume, thereby maximizing the treatment efficiency of the system, and (2) to provide optimum monitoring and vapor extraction points to ensure minimal migration of the vapor plume and no undetected migration of either the dissolved phase or vapor phase plumes. In shallow applications, in large plume areas, or in locations under buildings or pavements, horizontal vapor extraction wells are very cost effective and efficient for controlling vapor migration. Exhibit VIII-19 is a typical layout for a system that surrounds and contains a plume and includes sparging wells and vapor extraction wells.

The number and location of extraction wells (if needed) can be determined by using several methods as discussed in Chapter II: Soil Vapor Extraction. However, the following general points should be considered:

- Closer well spacing is often appropriate in areas of high contaminant concentrations in order to enhance air distribution (and oxygen delivery rate), thus increasing the rate of biodegradation.
- If a surface seal exists or is planned for the design, the extraction wells can be spaced slightly farther apart. Surface seals force air to be drawn from a greater distance rather than directly from the surface.
- At sites with stratified soils, wells screened in strata with low permeabilities might require closer well spacing than wells screened in strata with higher permeabilities.

Exhibit VIII-18
Biosparging/Vapor Extraction Well Configurations

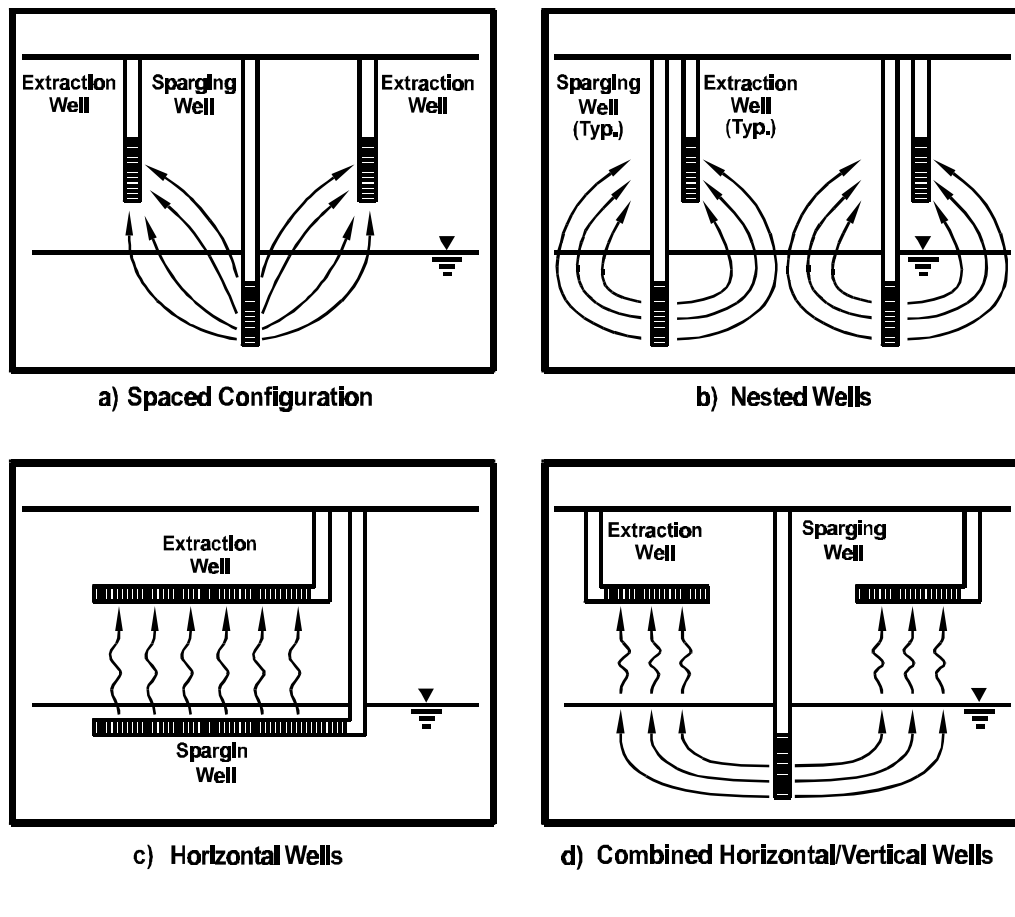

Source: "Advances in Air Sparging Design," *The Hazardous Waste Consultant*, Vol. 11, Issue 1, January/February 1993, p. 1-4.

Well Construction. Sparging wells are generally constructed of 1- to 5-inch PVC, galvanized steel, or stainless steel pipe. The screened interval is normally 1-3 feet in length and is generally set 5-15 feet below the deepest extent of adsorbed contaminants. Setting the screen at a deeper interval requires higher pressures on the system, but generally does not achieve higher sparge rates. Increased screen length will not improve system efficiency because air tends to exit at the top portion of the screen where hydraulic pressure head is lower. Sparge points must be properly grouted to prevent short circuiting of the air. Horizontal injection wells should be designed and installed carefully to ensure that air exits from along the entire screen length. Perforated pipe, rather than well screening, is sometimes preferred for horizontal wells. Exhibits VIII-20 and VIII-21 present typical vertical and horizontal sparging well constructions, respectively.

Exhibit VIII-19
Combined Biosparging/Vapor Extraction System Layout

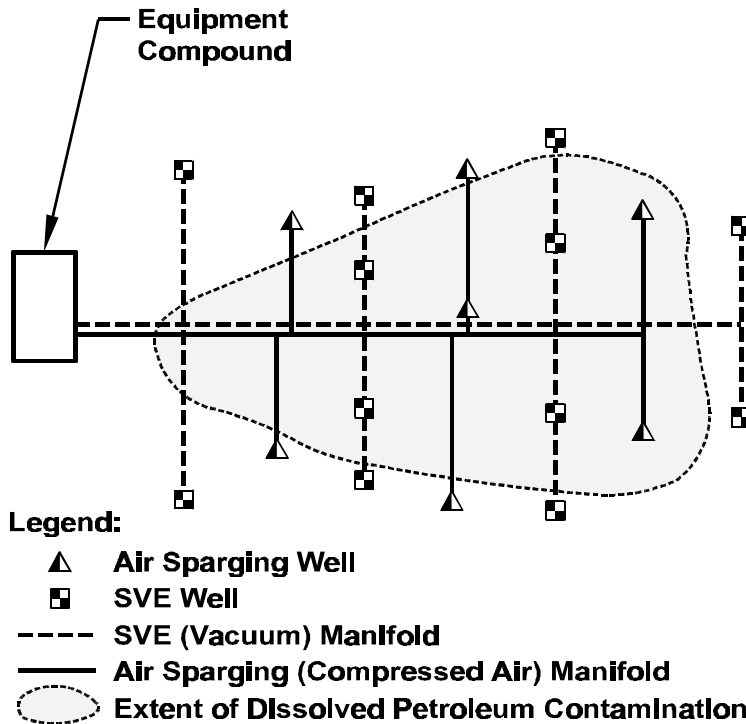

Injection wells should be fitted with check valves to prevent potential line fouling. Fouling occurs when pressure in the saturated zone forces water up the sparge point while the system is shut down. Each sparging well should also be equipped with a pressure gauge and flow regulator to enable adjustments in sparging air distribution. Refer to Chapter II: Soil Vapor Extraction for vapor extraction well details.

Manifold Piping

Manifold piping connects sparging wells to an air compressor. Piping can be placed above or below grade depending on site operations, ambient temperature, and local building codes. Below-grade piping is more common and is installed in shallow utility trenches that lead from the sparging wellhead vault(s) to a central equipment location. The piping can either be manifolded in the equipment area or connected to a common compressor main that supplies the wells in series; in this case, flow control valves are located at the wellhead. Piping to the well locations should be sloped toward the well so that condensate or entrained groundwater will flow back toward the well.

**Exhibit VIII-20
Vertical Sparging Well Construction**

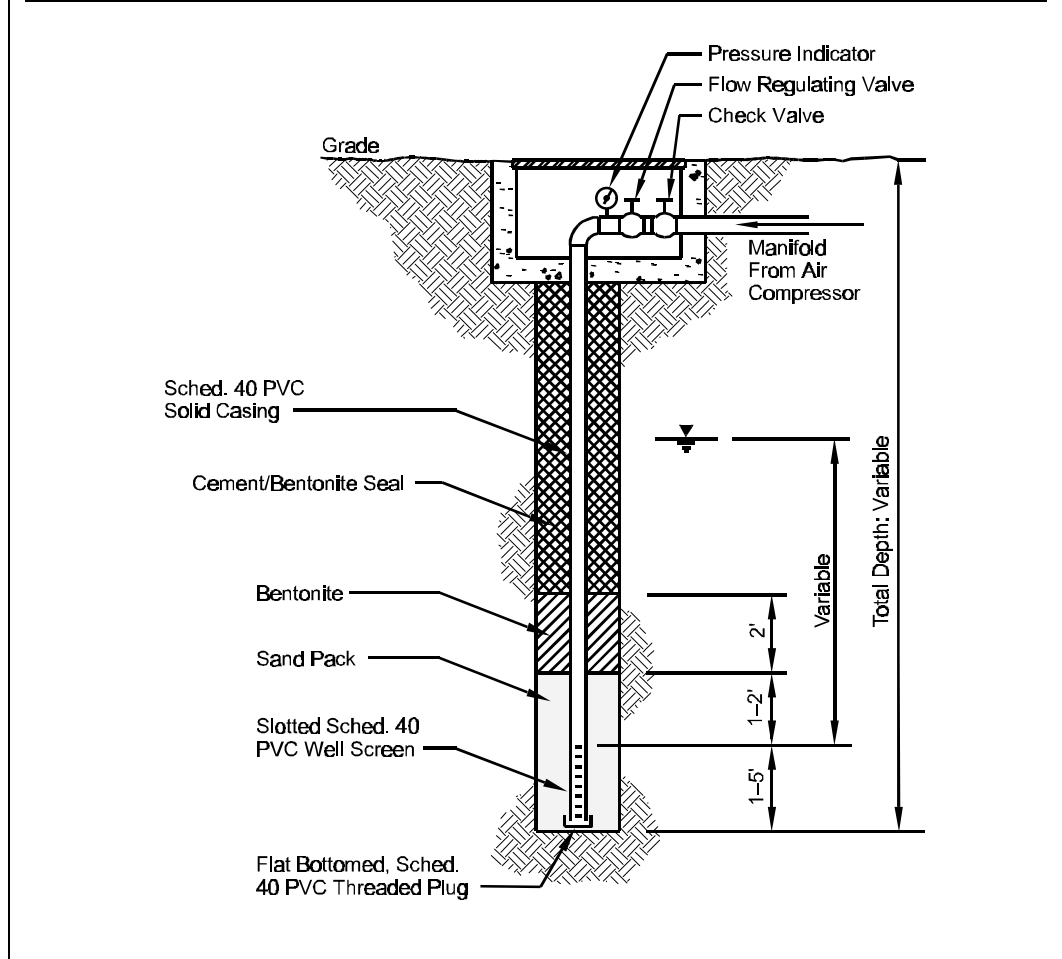

The pressurized air distribution system can be made of metal pipe or rubber-reinforced air hose. PVC pipe should not be connected directly to the compressor because of the high temperatures of air leaving the compressor which can diminish the integrity of the PVC. If pipe trenches are used for the distribution system, they must be sealed to prevent short circuiting of air flow.

Compressed Air Equipment

An oil-free compressor or a standard compressor equipped with downstream coalescing and particulate filters should be used to ensure that no contaminants are injected into the saturated zone. The compressor should be rated for continuous duty at the maximum expected flow rate and pressure to provide adequate flexibility during full operations.

Exhibit VIII-21
Horizontal Sparging Well Construction

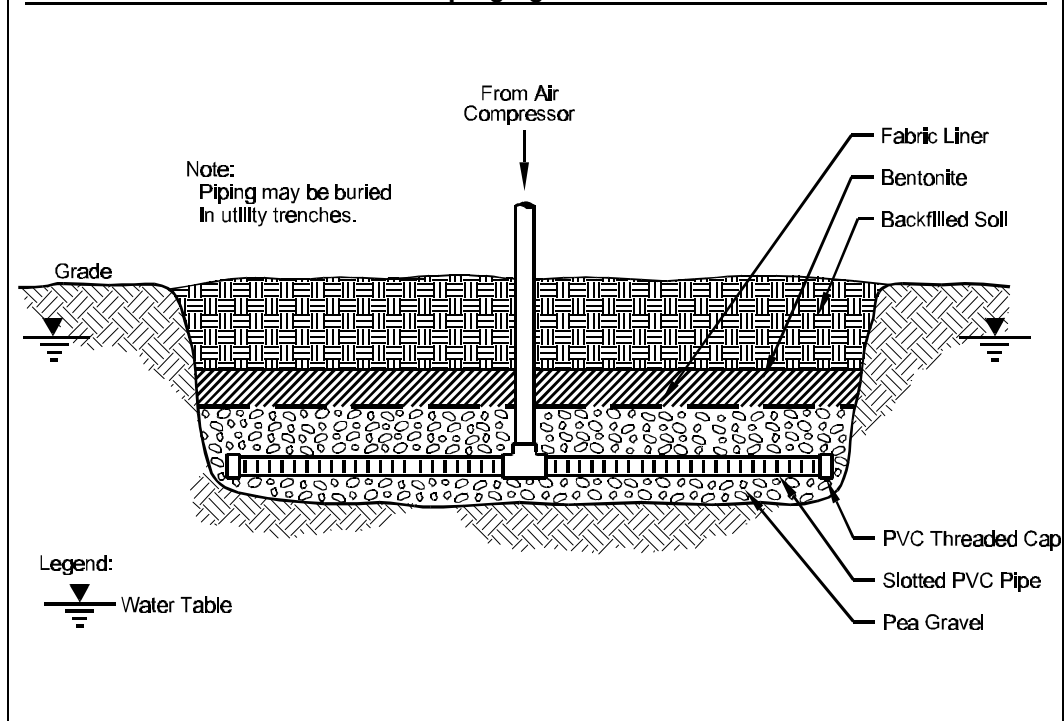

Monitoring And Controls

The parameters typically monitored in a sparging system include:

- Pressure
- Air/vapor flow rate
- Carbon dioxide and oxygen concentration in soil vapor and groundwater
- Constituent concentrations in soil vapor and groundwater
- Nutrient delivery rate

The equipment in a sparging system used to monitor these parameters provides the information necessary to make appropriate system adjustments and track remedial progress. The control equipment in a sparging system allows the flow and sparge pressure to be adjusted at each sparging well of the system as necessary. Control equipment typically includes flow control valves or regulators. Exhibit VIII-22 lists typical monitoring and control equipment for a biosparging system, the location for each of these pieces of equipment, and the types of equipment that are available.

Exhibit VIII-22
Monitoring And Control Equipment

<u>Monitoring Equipment</u>	<u>Location In System</u>	<u>Example Of Equipment</u>
Flow meter	<ul style="list-style-type: none"> <input type="radio"/> At each sparge and vapor extraction well head <input type="radio"/> Manifold to blower <input type="radio"/> Stack discharge <input type="radio"/> Nutrient manifold 	<ul style="list-style-type: none"> <input type="radio"/> Pitot tube <input type="radio"/> In-line rotameter <input type="radio"/> Orifice plate <input type="radio"/> Venturi or flow tube <input type="radio"/> Turbine wheel
Pressure gauge	<ul style="list-style-type: none"> <input type="radio"/> At each sparge and vapor extraction well head or manifold branch <input type="radio"/> Before blower (before and after filters) <input type="radio"/> Before and after vapor treatment 	<ul style="list-style-type: none"> <input type="radio"/> Manometer <input type="radio"/> Magnehelic gauge <input type="radio"/> Vacuum gauge
Sampling port	<ul style="list-style-type: none"> <input type="radio"/> At each vapor extraction well head or manifold branch <input type="radio"/> Manifold to blower <input type="radio"/> Blower discharge 	<ul style="list-style-type: none"> <input type="radio"/> Hose barb <input type="radio"/> Septa fitting
<u>Control Equipment</u>		
Flow control valves/ regulators	<ul style="list-style-type: none"> <input type="radio"/> At each vapor extraction well head or manifold branch <input type="radio"/> Dilution or bleed valve at manifold to blower <input type="radio"/> At header to each sparge point 	<ul style="list-style-type: none"> <input type="radio"/> Ball valve <input type="radio"/> Gate valve <input type="radio"/> Dilution/ambient air bleed valve <input type="radio"/> Gate valve <input type="radio"/> Dilution/ambient air bleed valve

Evaluation Of Operation And Monitoring Plans

The system operation and monitoring plan should include both system startup and long-term operations. Operations and monitoring are necessary to ensure optimal system performance and to track the rate of contaminant mass removal/reduction.

Startup Operations

The startup phase should begin with only the SVE portion of the system (if used) as described in Chapter II. After the SVE system is adjusted, the air sparging system should be started. Generally, 7 to 10 days of manifold valving adjustments are required to adjust the air sparging system. These adjustments should balance flow to optimize the carbon dioxide production and oxygen uptake rate. Monitoring data should include sparge pressure and flows, vacuum readings for SVE, depth of groundwater, vapor concentrations, dissolved oxygen levels, CO₂ levels, and pH. During the initial start up, these parameters should be monitored hourly once the flow is stabilized. Vapor concentration should also be monitored in any nearby utility lines, basements, or other subsurface confined spaces. Other monitoring of the system should be done in accordance with the SVE requirements from Chapter II.

Long-Term Operations

To evaluate the performance of a biosparging system the following parameters should be monitored weekly to biweekly after the startup operation:

- Contaminant levels, carbon dioxide level, dissolved oxygen level, and pH in the groundwater.
- Contaminant level, oxygen, and carbon dioxide in the effluent stack and the manifold of the SVE system (if used).
- Pressures and flow rates in the sparging wells and, if SVE is used, in the extraction wells.

It should be noted that the samples from the groundwater monitoring wells that will be analyzed to track dissolved contaminant concentrations should be collected after a short period of time following system shutdown. Sampling at these times allows the subsurface environment to reach equilibrium. Samples collected during sparging operations may have lower concentrations of dissolved contaminants than does the surrounding aquifer. This result could lead to the erroneous conclusion that remediation is occurring throughout the aquifer because the monitoring wells may serve as preferential flow paths for the injected air.

Exhibit VIII-23 provides a brief synopsis of system monitoring requirements.

Exhibit VIII-23
System Monitoring Recommendations

Phase	Monitoring Frequency	What To Monitor	Where To Monitor
Startup (7-10 days)	At least daily	<input type="radio"/> Sparge pressure <input type="radio"/> Flow	<input type="radio"/> Air sparging wellheads <input type="radio"/> Sparge and extraction wells (if used) <input type="radio"/> Manifold <input type="radio"/> Extraction wells (if SVE is used)
		<input type="radio"/> Vacuum readings (if SVE is used) <input type="radio"/> D.O., CO ₂ , pH	<input type="radio"/> Groundwater and soil vapor monitoring points
		<input type="radio"/> Depth to groundwater	<input type="radio"/> Groundwater monitoring wells
Remedial (ongoing)	Weekly to bi-weekly	<input type="radio"/> Vacuum readings	<input type="radio"/> Extraction wells (if SVE is used)
		<input type="radio"/> Vapor concentrations	<input type="radio"/> Effluent stack (if SVE is used) <input type="radio"/> Manifold (if SVE is used)
		<input type="radio"/> Sparge pressure and flow	<input type="radio"/> Air sparging wellheads
		<input type="radio"/> D.O., CO ₂ , pH	<input type="radio"/> Groundwater and soil vapor monitoring points
	Quarterly to annually	<input type="radio"/> Dissolved constituent concentrations	<input type="radio"/> Groundwater monitoring wells

Remedial Progress Monitoring

Monitoring the performance of the biosparging system in reducing contaminant concentrations in the saturated zone is necessary to determine if remedial progress is proceeding at a reasonable pace. A variety of methods can be used. One method includes monitoring contaminant levels in the groundwater in monitoring wells and, if vapor extraction is used, vapors in the blower exhaust. The vapor and contaminant concentrations are then each plotted against time.

The plot can be used to show the impact of the biosparging operation. As biosparging reaches the limit of its ability to biodegrade further, the reduction of dissolved constituents reaches asymptotic conditions. This effect is also reflected in the concentrations of oxygen, CO₂, and VOC in the vapors released from the system. A plot of this effect is demonstrated in Exhibit VIII-24. When asymptotic behavior begins to occur, the operator should evaluate alternatives that increase the mass transfer removal rate (e.g., pulsing, or turning off the system for a period of time and then restarting it). Other more aggressive steps to further reduce constituent concentrations can include the installation of additional sparging points or vapor extraction wells.

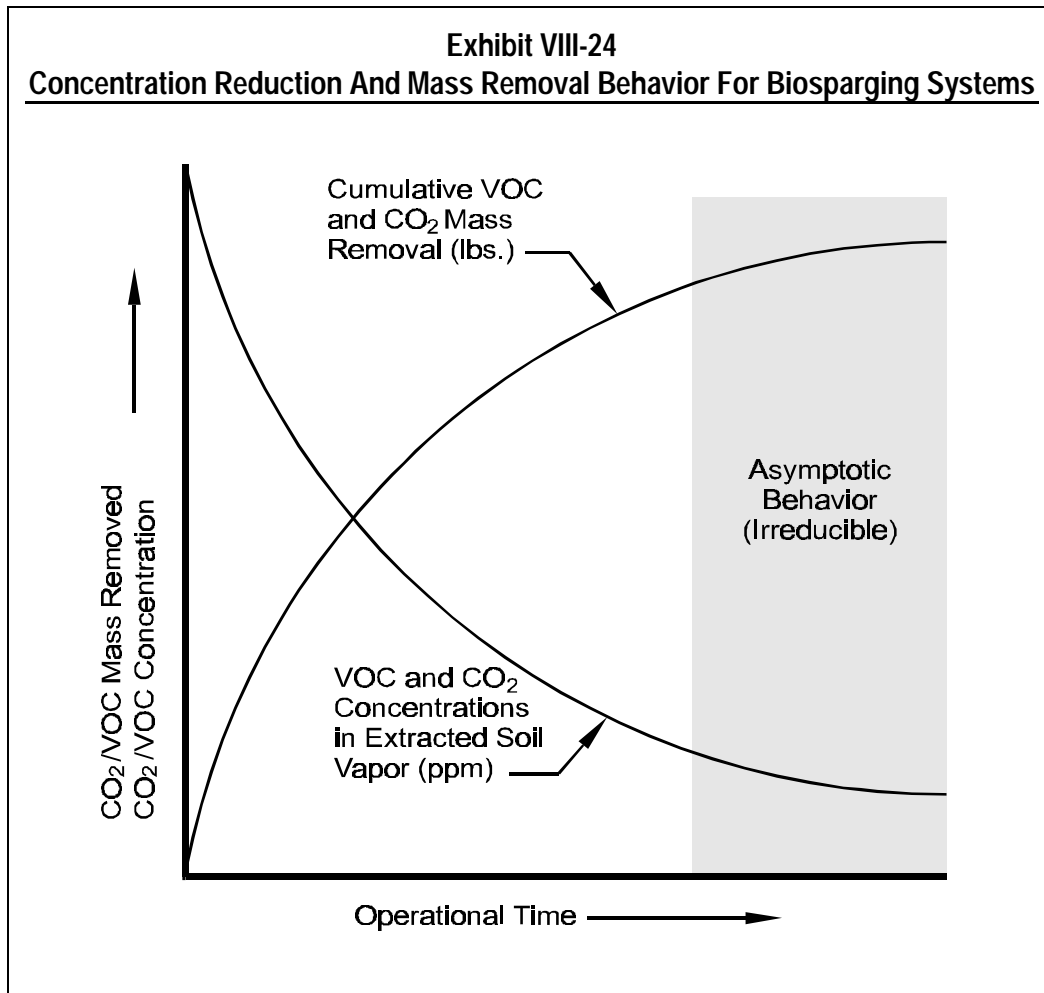

If asymptotic behavior is persistent for periods greater than about six months and the concentration rebound is sufficiently small following periods of temporary system shutdown, the performance of the biosparging system should be reviewed with regulatory agencies to determine whether remedial goals have been reached. If further contaminant reduction is desired, another remedial technology may need to be considered.

References

- Norris, R.D., Hinchee, R.E., Brown, R.A., McCarty, P.L., Semprini, L., Wilson, J.T., Kampbell, D.H., Reinhard, M., Bower, E.J., Borden, R.C., Vogel, T.M., Thomas, J.M., and C.H. Ward. *Handbook of Bioremediation*. Boca Raton, FL: CRC Press, 1994.
- Norris, R.D., Hinchee, R.E., Brown, R.A., McCarty, P.L., Semprini, L., Wilson, J.T., Kampbell, D.H., Reinhard, M., Bower, E.J., Borden, R.C., Vogel, T.M., Thomas, J.M., and C.H. Ward. *In-Situ Bioremediation of Ground Water and Geological Material: A Review of Technologies*. Ada, OK: U.S. Environmental Protection Agency, Office of Research and Development. EPA/5R-93/124, 1993.
- Riser-Roberts, E. *Bioremediation of Petroleum Contaminated Sites*. NCEL, Port Hueneme, CA: C. K. Smoley Publishers, CRC Press, 1992.
- Flathman, P.E. and D.E. Jerger. *Bioremediation Field Experience*. Environmental Research Laboratory, Ada, OK: Lewis Publishers, CRC Press, Inc., 1994.
- Weston, Inc., Roy F. *Remedial Technologies for Leaking Underground Storage Tanks*. University of Massachusetts, Amherst, MA: Lewis Publishers, 1988.
- U.S. Environmental Protection Agency (EPA). *A Technology Assessment of Soil Vapor Extraction and Air Sparging*. Cincinnati, OH: Office of Research and Development. EPA/600/R-92/173, 1992.

Checklist: Can Biosparging Be Used At This Site?

This checklist can help you to evaluate the completeness of the CAP and to identify areas that require closer scrutiny. As you go through the CAP, answer the following questions. If the answer to several questions is no, you will want to request additional information to determine if biosparging will accomplish the cleanup goals at the site.

1. Site Factors

Yes No

- Is the aquifer clear of floating free product?
- Is the soil intrinsic permeability greater than 10^{-9} cm²?
- Is the soil free of impermeable layers or other conditions that would disrupt air flow?
- Is soil temperature between 10°C and 45°C during the proposed treatment season?
- Is the pH of groundwater between 6 and 8?
- Is the total heterotrophic bacteria count > 1,000 CFU/gram dry soil?
- Is the carbon:nitrogen:phosphorus ratio between 100:10:1 and 100:1:0.5?
- Is the dissolved iron concentration at the site < 10 mg/L?
- Is vapor migration of constituents controlled?

2. Constituent Characteristics

Yes No

- Are constituents all sufficiently biodegradable?
- Is the concentration of Total Petroleum Hydrocarbon ≤ 50,000 ppm and heavy metals ≤ 2,500 ppm?
- Are the constituent vapor pressures less than 0.5 mm Hg?
- Are the Henry's law constants for the constituents present lower than 100 atm?

3. Evaluation Of The Biosparging System Design

Yes No

- Examine the sparging air pressure. Will the proposed pressure be sufficient to overcome the hydraulic head and capillary forces?
- Is the proposed well density appropriate, given the total area to be cleaned up and the radius of influence of each well?
- Do the proposed well screen intervals account for contaminant plume location at the site?
- Is the proposed well configuration appropriate for the site conditions present?
- Is the air compressor selected appropriate for the desired sparge pressure?
- If nutrient addition is needed, are nutrient formulation and delivery rates appropriate for the site, based on laboratory or field studies?
- Have background concentrations of oxygen and CO₂ (measured in pilot studies) been taken into account in establishing operating requirements?

4. Operation And Monitoring Plans

Yes No

- Are manifold valving adjustments proposed during the first 7 to 10 days of operation?
- Are hourly recordings of injection and extraction rates, pressures, depth to groundwater, hydraulic gradient, and VOC levels proposed during the first 7 to 10 days of operation?
- Is daily monitoring of injection rates proposed during the first 7 to 10 days of operation?
- Are biweekly to monthly measurements of contaminant levels in groundwater, vapor wells, and blower exhausts proposed?
- Are biweekly to monthly measurements of vapor concentration proposed?