

3.2.2 Environmental Consequences

The primary issues related to water resources include 1) reduction in surface and ground water quantity for current users and water-dependent resources from pit dewatering and production well withdrawal; 2) impacts related to the water quality of the postmining pit lakes; 3) impacts to ground and surface water quality from the construction, operation, and closure of mineral processing mills, tailings storage facilities, heap leach facilities, waste rock storage facilities, and other mining and processing facilities; and 4) impacts from flooding, erosion, and sedimentation associated with mine construction, operation, or closure activities.

Impacts to water resources would be significant if the Proposed Action or No Action alternative result in the following:

Surface Water

- Measurable reduction in the baseflow of perennial streams or in perennial spring flows
- Degradation of the quality of surface water based on applicable state or federal regulations for designated or appropriate beneficial uses, including but not limited to, municipal or domestic water supply, irrigation, livestock watering, or support of terrestrial, avian, and aquatic life
- Alteration of drainage patterns or channel geometry resulting in accelerated erosion and sedimentation
- Measurable reduction of seasonal surface flows caused by withdrawal of contributing watershed area or by channel blockages, if important for biological resources
- Damage to project facilities and on- and off-site resources during operation or postclosure as a result of inadequate drainage control features

Ground Water

- Reduction of static ground water levels that could adversely affect water supply, agricultural, or industrial wells caused by project dewatering or postmining pit lake development

- Degradation of ground water quality downgradient from the project facilities such that one or more water quality constituents would exceed Nevada or federal primary or Nevada secondary enforceable maximum contaminant levels established to protect human health from potentially toxic or undesirable substances in drinking water; or where the quality of the ground water already exceeds the maximum contaminant levels for drinking water, the quality would be lowered such that it would render those waters unsuitable for other existing or potential beneficial use

Other potential impacts to wetlands and riparian areas are discussed in the Vegetation section (3.4) of this EIS. Potential impacts resulting from the transportation, storage, and use of hazardous substances are addressed in the Hazardous Materials section (3.15).

3.2.2.1 Proposed Action

Water Quantity Impacts

Numerical Flow Modeling. A three-dimensional numerical ground water flow model was developed to estimate effects to ground water and surface water resources from the mining alternatives evaluated as part of this EIS. Specifically, the numerical model was used to evaluate or estimate the following: 1) mine dewatering rates required (for each mine component) throughout the mine life; 2) areal extent, magnitude, and timing of drawdown and recovery of ground water levels through the mining and postmining periods; 3) development of postmining pit lakes, ground water inflow and outflow through the pits, and final surface water elevations of the pit lakes (No Action alternative); 4) postmining ground water elevations in backfilled pits, and ground water inflow and outflow through backfilled pits (Proposed Action); 5) changes in ground water levels over time resulting from reduced recharge beneath waste rock facilities; 6) changes in ground water levels over time resulting from pumping from the production well field and chloride mitigation well field; and 7) changes in the water balance in the Buffalo Valley and Lower Reese River Valley hydrographic areas.

Baker Consultants, Inc. (1997a, 2000a) performed the numerical modeling using the U. S. Geological Survey ground water flow program MODFLOW. MODFLOW was designed to simulate flow through porous media. The MODFLOW model assumes

3.0 AFFECTED ENVIRONMENT AND ENVIRONMENTAL CONSEQUENCES

that ground water flow in the bedrock aquifer is essentially equivalent, on a site and regional scale, to porous media flow. A detailed explanation of the conceptual hydrogeologic model, modeling approach and setup, steady-state and transient calibration, sensitivity analysis, and simulations is presented in Baker Consultants, Inc. technical reports (1997a, 2000a), available for review at the BLM's Battle Mountain Field Office.

The model domain is rectangular in shape and encompasses the same general area as the hydrologic study area shown in **Figure 3.2-1**, except that the northern boundary of the model is approximately 4 miles south of the northern boundary of the study area. The reason for the difference is that the northern boundary of the model was selected to roughly match the observed ground water divide in the Battle Mountain range, which falls a few miles south of the northern boundary of the hydrologic study area. The model domain covers approximately 368 square miles and includes the project site, Willow Creek, and parts of the Lower Reese River Valley and Buffalo Valley hydrographic areas. The numerical model contains seven layers to represent the principal hydrostratigraphic units identified in the hydrologic study area. In order to provide more detailed flow information in the project area, the grid cell dimensions vary horizontally from 2,000 feet by 2,000 feet at the outer margins of the model to 100 feet by 100 feet in the mine area. The more detailed discretization in the mining area allows the model to more accurately match observed hydrologic features (such as fault zones and steep hydraulic gradients), spring and well locations, mine pit geometry, and ground water levels in the project vicinity. In addition, the thickness of the model blocks in each layer varies across the model domain to represent the actual thickness of each hydrostratigraphic unit represented. Blocks within each layer are assigned hydraulic properties that are believed to be representative of the hydrostratigraphic units that exist in those areas. Faults zones are represented in the model as a linear zone of cells with assigned fault hydraulic properties. The hydraulic conductivity assigned to the faults was calculated to yield the observed head loss across the fault zone (Baker Consultants, Inc. 1997a).

Pit Dewatering and Water Management. Under the Proposed Action, three of the proposed pits (Reona, Phoenix and Midas) would extend below the water table and therefore require dewatering. The maximum depth of the Iron Canyon Pit is

above the water table and therefore is not expected to produce ground water. The numerical ground water flow model was used to estimate dewatering requirements for each of these pits throughout the mining operations. As shown in **Table 3.2-12**, the average annual dewatering from all pits is estimated to range from 150- to 1,500-gpm over the first 24 years of the project. Between years 24 to 28, no pit dewatering is expected.

In addition to mine dewatering, as shown in **Table 3.2-12**, ground water pumping would continue through the project life at extraction wells PW-1, PW-2a, and PW-4 (**Figure 2-4**) to provide clean water for mine process and mine reclamation activities. Pumping also would continue at CM-1 and proposed extraction wells CCPW-1 and CCPW-2 (**Figure 2-4**) at a combined rate of approximately 2,000 gpm for 26 years to mitigate the chloride plume near the tailings disposal area. Water extracted from the chloride plume would be used for makeup water for the heap leach and milling operations (Baker Consultants, Inc. 2000a).

Impacts to Ground Water Levels. For this impact analysis, the area that is predicted to experience a change in ground water elevation of 10 feet or more from mine dewatering and water management activities was selected as the area of potential concern regarding impacts to water resources. Changes in ground water levels of less than 10 feet generally were not considered in this analysis because these changes would probably be indistinguishable from natural seasonal and annual fluctuations in ground water levels. For comparative purposes, changes in water levels represent the difference between the model simulated ground water elevations and the baseline ground water elevations that existed in June 1996.

As described previously, the June 1996 ground water elevations were selected as a baseline for comparison since they represent a period of relatively stable ground water conditions compared to subsequent months and years (Baker Consultants, Inc. 2000a). Subsequent water levels have been more variable due to response to pit dewatering and periods of unusually high precipitation.

Numerical model simulations of mine-induced drawdowns resulting from the Proposed Action at several different periods (years 25, 50, 75, 100, 150, 200 and 400) during the mining and

**Table 3.2-12
Estimated Pit Dewatering and Well Field Production Rates
(Proposed Action)**

Model Year	PIT DEWATERING (gpm)					PRODUCTION WELLS (gpm)		
	Phoenix Pit	Reona Pit	Midas Pit	Iron Canyon Pit	Total All Pits	Well Field	Chloride Mitigation Well Field	Total All Production Wells
1	600	0	0	0	600	1,990	2,000	3,990
2	200	0	0	0	200	2,116	2,000	4,116
3	150	0	0	0	150	2,116	2,000	4,116
4	150	0	0	0	150	2,116	2,000	4,116
5	150	0	0	0	150	2,116	2,000	4,116
6	150	0	50	0	200	2,116	2,000	4,116
7	150	0	100	0	250	2,016	2,000	4,016
8	150	0	100	0	250	2,066	2,000	4,066
9	150	0	0 (BF)	0	150	2,116	2,000	4,116
10	150	0	20 (BF)	0	170	2,146	2,000	4,146
11	150	0	40 (BF)	0	190	2,126	2,000	4,126
12	100	0	70 (BF)	0	170	2,146	2,000	4,146
13	150	0	0 (BF)	0	150	2,116	2,000	4,116
14	150	0	0 (BF)	0	150	2,116	2,000	4,116
15	150	20	0	0	170	2,146	2,000	4,146
16	150	100	0	0	250	2,066	2,000	4,066
17	150	0 (BF)	0	0	150	2,166	2,000	4,166
18	150	0 (BF)	0	0	150	2,166	2,000	4,166
19	150	0 (BF)	0	0	150	1,466	2,000	3,466
20	850	0	0	0	850	816	2,000	2,816
21	1,500	0	0	0	1,500	1,316	2,000	3,316
22	1,000	0	0	0	1,000	1,116	2,000	3,116
23	1,200	0	0	0	1,200	1,766	2,000	3,766
24	550	0	0	0	550	1,766	2,000	3,766
25	0 (BF)	0	0	0	0	2,316	2,000	4,316
26	0 (BF)	0	0	0	0	2,316	2,000	4,316
27	0 (BF)	0	0	0	0	416	400	816
28	0 (BF)	0	0	0 (BF)	0	1,100	0	1,100
29	0	0	0	0	0	350	0	350
30	0	0	0	0	0	350	0	350
31	0	0	0	0	0	350	0	350

Source: Baker Consultants, Inc. 2000a.

BF= Backfill of pit underway

3.0 AFFECTED ENVIRONMENT AND ENVIRONMENTAL CONSEQUENCES

postmining period were evaluated to determine the maximum depth, areal extent, and timing of drawdown. Model year 1 represents the first year of mining, and year 28 would be the final year of active mining. Mine dewatering is expected to cease at the end of year 24, and the pumping from the production well field would cease in year 32 (**Table 3.2-12**).

As shown in **Figure 3.2-13**, in model year 25 (near the end of mining), the cone of drawdown as defined by the 10-foot drawdown contour is predicted to extend approximately 9 miles in a north-south direction and 7 miles in an east-west direction. This drawdown actually represents the merging of two cones of drawdown: one centered at the mine area in Copper Canyon resulting from pit dewatering, and one centered in the alluvial basin at the chloride mitigation well field. The maximum drawdown would occur near the end of mining with approximately 650 feet of drawdown in the Phoenix Pit area and over 50 feet of drawdown in the chloride mitigation well field area.

By model year 50 (**Figure 3.2-14**) (26 years after active mine dewatering ceases, and 19 years after chloride plume pumping ceases), drawdown in the alluvium in the vicinity of the chloride mitigation well field is predicted to fully recover compared with conditions at the start of the Proposed Action mining period. Conversely, in the pit dewatering areas in Copper Canyon, the areal extent of drawdown is predicted to continue to expand after mining ceases. Comparison of **Figures 3.2-13, 3.2-14, and 3.2-15** illustrates that the drawdown area centered in Copper Canyon is predicted to continue to expand between model years 25, 50, and 150. The cone of drawdown centered on Copper Canyon is predicted to reach a maximum areal extent at approximately model year 150, measuring approximately 6 miles in a north-south and 4 miles in an east-west direction. This cone of drawdown would extend to the northeast into the upper tributary areas of Galena Canyon (including the Cow, Duck, Butte, Iron Canyon areas), east to Philadelphia Canyon, and south to the edge of the alluvial basin fill at the mouth of Copper Canyon.

After model year 150, the drawdown area gradually contracts but is not predicted to fully recover. At model year 400 (**Figure 3.2-16**), the area encompassed by the 10-foot drawdown contour would still extend into the upper Galena Canyon and Philadelphia Canyon areas, and south nearly to the valley fill at the mouth of Copper Canyon. This long-term residual drawdown pattern predicted for the Proposed

Action results from a substantial reduction in local recharge predicted for areas to be covered by reclaimed waste rock facilities.







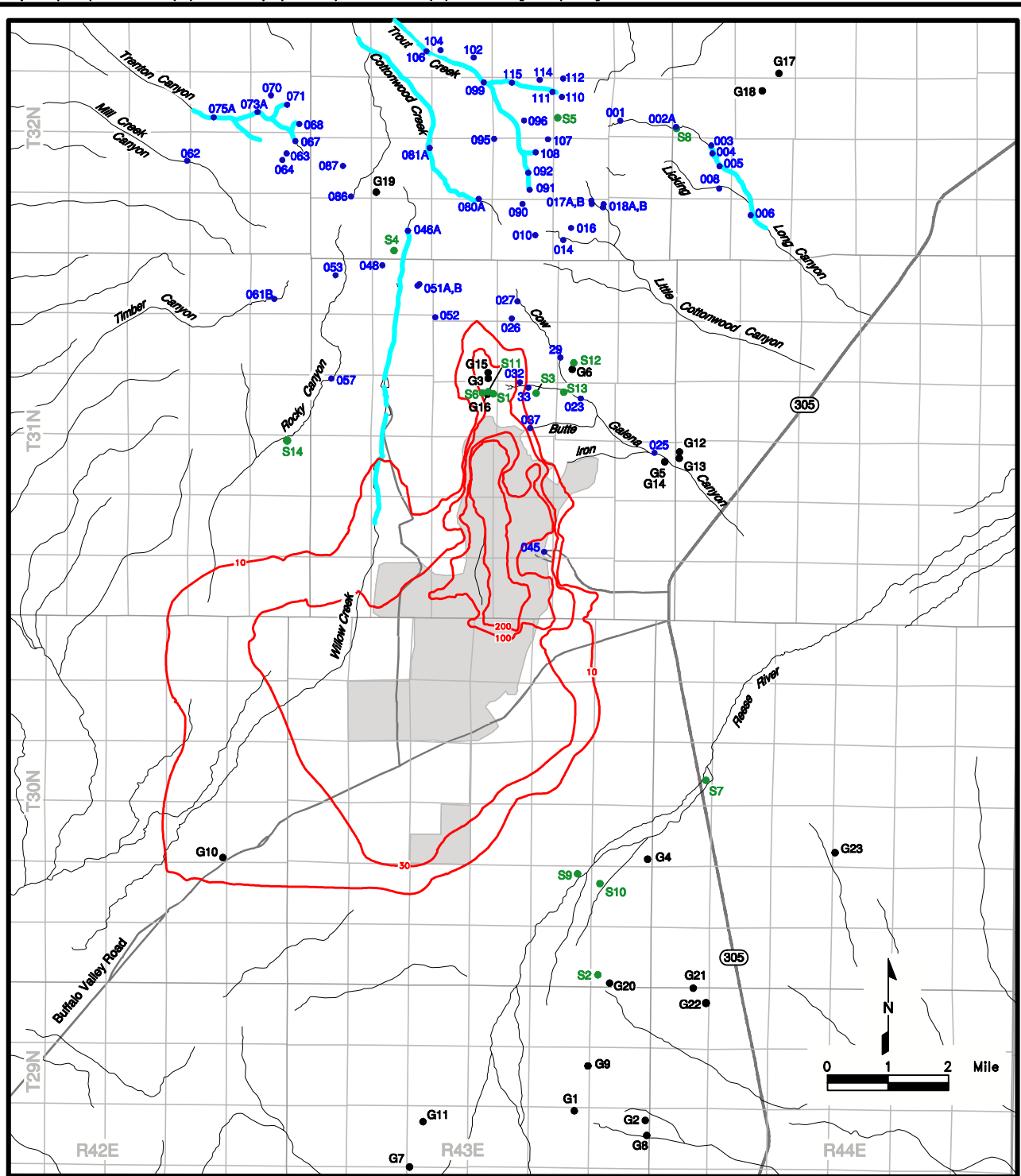

The predicted maximum ground water recovery elevations in the vicinity of the mine pits and the estimated ground water flow rates through the backfilled mine pits are presented in **Table 3.2-13**. Based on the model results, the proposed backfill elevations are anticipated to be adequate to preclude pit lake development. Ground water is predicted to flow through the saturated backfilled pit material. Potential water quality impacts associated with ground water outflow from the pit backfill materials are discussed in the Water Quality section presented below.

Pit Lake Development. Under the Proposed Action, all of the open pits that extend below the water table would be completely or partially backfilled to preclude pit lake development. Therefore, no impacts associated with pit lake development are anticipated.

Impacts to Perennial Streams and Springs. As described above, mine-induced drawdown resulting from the Proposed Action is predicted to cause a reduction in ground water levels over an area that extends outside of the project boundary. For the purposes of discussion, the spring and seep locations will be referred to throughout the remainder of this section simply as springs. The stream reaches and spring sites located in this area can be characterized as either ephemeral or perennial. Ephemeral stream reaches and spring sites only flow during or after wet periods in response to rainfall or runoff events. By definition, these surface waters are not controlled by discharge from the regional ground water system. During the low-flow period of the year (late summer through fall), ephemeral stream reaches and spring sites would typically be dry. In contrast, perennial stream reaches and springs generally flow throughout the year. Flows observed during the wet periods, that typically extend from spring through early summer, include a combination of surface runoff and ground water discharge, whereas flows observed during the low-flow period are sustained entirely by discharge from the ground water system. If the flow from these springs relies on the aquifer that is being dewatered, a reduction of ground water levels from mine-induced drawdown could reduce the ground water discharge to perennial stream reaches or springs located within the ground water drawdown area. A reduction of flow in perennial streams or springs could reduce the length of



Explanation

- | | | | | |
|---|---------------------------|---|----|--|
|  | Road |  | G# | Ground Water Right on File at State Engineer's Office |
|  | Drainage |  | S# | Surface Water Right on File at State Engineer's Office |
|  | Perennial Stream |  | 0# | Perennial Spring |
|  | Drawdown (Feet) | | | |
|  | Recovery (Feet) | | | |
|  | Project Facility Boundary | | | |

Source for Base: Brown and Caldwell 1998b, JBR 1996d.g
 Source for Drawdown: Baker Consultants Inc. 2000a

Phoenix Project

Figure 3.2-13

**Predicted Change in
 Ground Water Levels at
 Model Year 25
 (Proposed Action)**

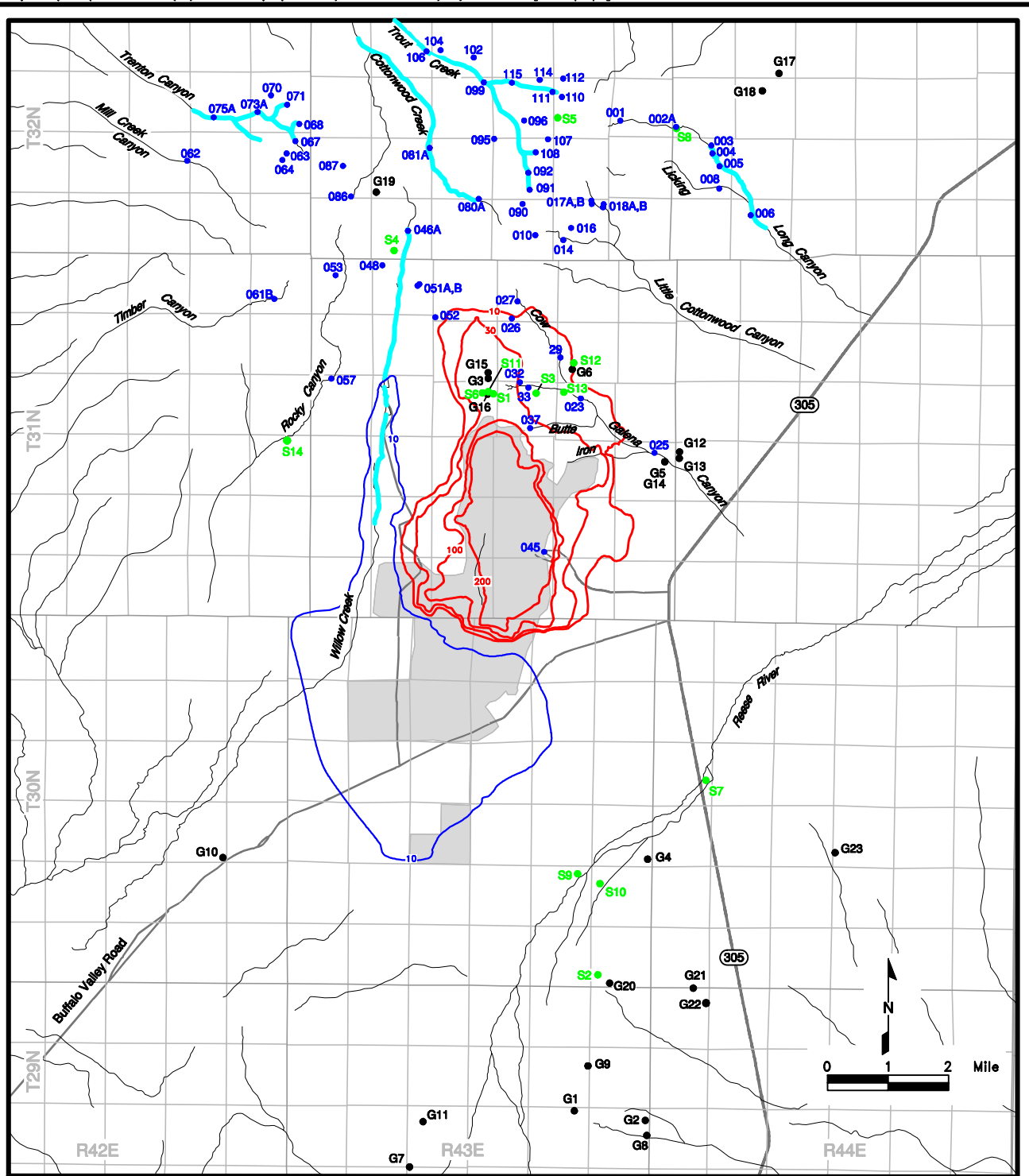

Explanation

- Road
- Drainage
- Perennial Stream
- Drawdown (Feet)
- Recovery (Feet)
- Project Facility Boundary

- G8● Ground Water Right on File at State Engineer's Office
- S9● Surface Water Right on File at State Engineer's Office
- 037● Perennial Spring

Phoenix Project

Figure 3.2-14

**Predicted Change in
Ground Water Levels at
Model Year 50
(Proposed Action)**

Source for Base: Brown and Caldwell 1998b, JBR 1996d,g
Source for Drawdown: Baker Consultants Inc. 2000a

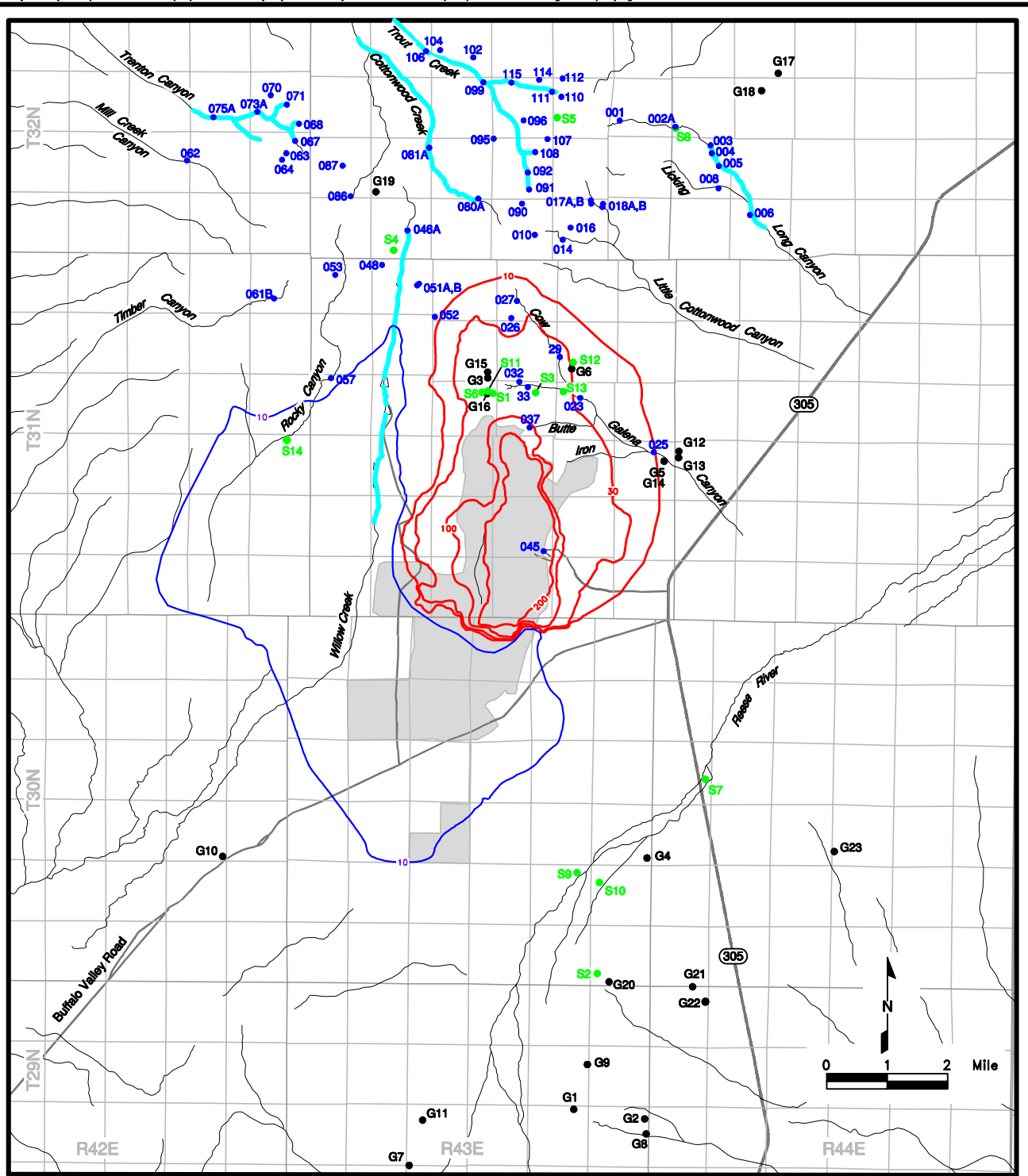

Explanation

- Road
- Drainage
- Perennial Stream
- Drawdown (Feet)
- Recovery (Feet)
- Project Facility Boundary

- G8 Ground Water Right on File at State Engineer's Office
- S9 Surface Water Right on File at State Engineer's Office
- 037 Perennial Spring

Phoenix Project

Figure 3.2-15

Predicted Change in Ground Water Levels at Model Year 150 (Proposed Action)

Source for Base: Brown and Caldwell 1998b, JBR 1996d,g
 Source for Drawdown: Baker Consultants Inc. 2000a

**Table 3.2-13
Predicted Final Ground Water Conditions in the Vicinity of the Backfilled Pits**

Mine Pit	Backfill Elevation (feet amsl)	Predicted Final Ground Water Elevation	Predicted Saturated Thickness of Pit Backfill	Predicted Maximum Ground Water Inflow to Pit Backfill (gpm)	Predicted Maximum Ground Water Outflow From Pit Backfill (gpm)
Phoenix Pit	6,060	6,020	1,040	144	105
Reona Pit	5,750	5,230	330	1	5
Midas Pit	5,200 - 5,700	4,870 – 5,080	0-360	25	22
Iron Canyon	5,830	5,230	0	NA	NA

Source: Baker Consultants, Inc. 2000a.

perennial stream reaches, reduce spring flow, and correspondingly reduce associated riparian/wetlands areas.

By the end of mining (model year 25), the drawdown area (defined by the 10-foot drawdown contour) is predicted to extend into the lower perennial reach of Willow Creek (**Figure 3.2-13**). As summarized in Section 3.2.1.2, the lower perennial reach is characterized as a gaining reach that is connected to the regional ground water system. A reduction in ground water levels in Willow Creek would likely reduce flows and possibly reduce the length of the perennial stream reach in this area. A reduction of flows in lower Willow Creek is considered a significant impact.

The ground water model was used to evaluate potential drawdown and recovery over time along the lower perennial reach of Willow Creek. The model results indicate that compared to baseline conditions, the ground water elevations would fully recover by approximately model year 40. Any reduction in flows that may have occurred due to drawdown also are expected to recover to pre-Phoenix Project conditions by this time.

Between model years 50 and 400, the cone of drawdown is predicted to be located as close as 0.5 mile east of Willow Creek. Excluding local perennial flows associated with spring discharge, there are no other perennial streams located within the predicted drawdown area.

As presented in **Table 3.2-14**, there are 10 inventoried perennial springs located within (or near) the predicted Phoenix Project drawdown area. The interconnection between these springs and the regional bedrock system that would be impacted by long-term, mine-induced drawdown is not well understood. In the late summer and fall, flow from these springs is supported entirely by

discharge from the ground water system. For this evaluation, it was assumed that any spring that was flowing during August, September, or October was perennial and dependent upon ground water discharge. **Perennial springs located in higher elevation areas (such as the Battle Mountain range) represent discharge either from the regional ground water system or from more isolated or perched aquifers residing above the regional ground water system. However, for this evaluation it** was conservatively assumed that all of the perennial springs located within the drawdown area could potentially be interconnected to the regional bedrock ground water system, and therefore could potentially be impacted. Impacts to these springs could range from reductions in flow to elimination of all flow. Spring 25, located near the mouth of Galena Canyon, is the largest spring in the area with measured flows of up to 20 gpm during the late summer to fall period. All of the other perennial springs identified in the drawdown area had flows during the late summer to fall period of 3 gpm or less, and most typically had flows of less than 1 gpm. In addition, most of these springs occur within areas that are predicted to experience long-term drawdown impacts. As a result, any flow reduction or elimination that occurs is likely to persist for the foreseeable future. Potential flow reductions in these springs are considered a significant impact.

Impacts to Surface Water Rights. As listed in **Table 3.2-15**, there are six surface water rights located within the predicted mine-induced drawdown area. Information from the State Engineer’s Office indicates that five of these are used for irrigation, stock watering, or a combination of irrigation/domestic supply. The one remaining surface water right is used for milling and domestic supply. Note that for the purpose of this evaluation, all surface water rights or

**Table 3.2-14
Perennial Springs and Seeps Located Within or Near¹ the Predicted Drawdown Area (Proposed Action)**

Spring ²	Location	Description	Flow Range (Aug, Sept, Oct. 1995, 1996) (gpm)	Amount of Predicted Drawdown			
				Model Year 25 (feet)	Model Year 50 (feet)	Model Year 150 (feet)	Model Year 400 (feet)
<i>Galena Canyon Drainage Area</i>							
23 (31-43-14-142) Alluvial Spring	Galena Canyon	Spring in alluvial channel	0-3	<10	10-30	10-30	10-30
25 (31-43-24-21) Alluvial Spring	Galena Canyon	Alluvial spring piped to home	12-20	<10	<10	10-30	<10
26 (31-41-3-34)	Cow Canyon	Colluvial source	1.0-1.4	<10	10-30	10-30	<10
27 (31-43-3-323)	Cow Canyon	Alluvial source	0-0.45	<10	<10	10-30	<10
29³ (31-43-11-31)	Cow Canyon	Alluvial, in channel source	<1	<10	10-30	30-50	10-30
32 (31-43-15-12)	Duck Creek Canyon	Adit discharge	0.55-0.88	10-30	10-30	30-50	<10
33³ (31-43-15-122)	Duck Creek Canyon	Colluvial spring	trickel	<10	10-30	30-50	10-30
37 (31-43-15-43)	Butte Canyon	Adit discharge at pipe	0.13-0.74	10-30	50-70	100-150	70-150
<i>Philadelphia Canyon Drainage Area</i>							
45 (31-43-27-44)		Spring discharge from old drill hole	<1.0-0.71	50-70	250-300	200-300	200-250
<i>Willow Creek Drainage Area</i>							
52 (31-43-4-33)	~ 0.6 mi. east of Willow Ck.	Seep	<0.5-0.5	<10	<10	<10	<10

¹Includes all springs located within the 10-foot drawdown contour and springs located outside of, but within approximately 0.5 mile of, the 10-foot drawdown contour.

²Number in bold references springs in this EIS; number in parenthesis is the original spring number designation provided in JBR 1996d and 1996g.

**Table 3.2-15
Predicted Reduction in Ground Water Levels at Surface Water Rights Locations
(Proposed Action)**

Map #	Application Number	Permit Status	Use	Model Year 25	Model Year 50	Model Year 150	Model Year 400
				(feet) ¹			
S1	0723	Vested	Irrigation	30-50	30-50	30-50	<10
S3	01725	Vested	Irrigation	<10	10-30	30-50	10-30
S6	04228	Vested	Stock	30-50	30-50	30-50	<10
S11	22759	Certificated	Milling & Domestic	30-50	30-50	30-50	<10
S12	24497	Certificated	Irrigation and Domestic	<10	~10	10-30	10-30
S13	28960	Certificated	Irrigation and Domestic	<10	10-30	30-50	10-30

¹Numbers indicate the predicted reduction in ground water levels at the water right location.
Note: Excludes water rights owned or controlled by BMG.

applications owned or controlled by BMG were excluded. The actual potential for impacts to individual water rights would depend on the site-specific hydrologic conditions that control surface water discharge. Only those waters sustained by discharge from the regional ground water system are likely to be impacted. For surface water rights that are dependant, at least in part, on ground water discharge, a potential reduction in ground water levels could reduce or eliminate the flow available at the point of diversion for the surface water right.

Impacts to Ground Water Rights. Potential impacts to ground water rights were evaluated by determining the potential drawdown and recovery of ground water levels over time at the point of diversion associated with inventoried ground water rights. All of the ground water rights located within the predicted mine-induced drawdown area associated with the Proposed Action are listed in **Table 3.2-16**. No other wells with water rights status are predicted to be affected by mine dewatering. There are five water rights located within the drawdown area with Certificated or Ready for Action status. According to the State Engineer's records, one of these water rights is used for domestic supply, one is used for stock watering, and the remaining three are used for mining and milling, placer mining, or a combination of mining and milling and domestic use. As shown in **Table 3.2-16**, the timing and duration of potential impacts varies for the different locations. Most of the predicted decline in water levels is predicted to eventually recover to nearly existing conditions in the postmining period between model years 150 and 400.

Lowering of water levels in water supply wells located at these points of diversion could potentially reduce yield, increase pumping costs, or make the well(s) unusable if the water level is

lowered below the pump setting or below the bottom of the well. Actual impacts would depend on the site-specific conditions, well completion details, and timing of the drawdown.

Impacts to the Regional Water Balance. The hydrologic study area includes portions of the Lower Reese River Valley and Buffalo Valley hydrographic areas (**Figure 3.2-1**). The numerical model was used to calculate annual budgets for selected representative years to evaluate the effects of mine-induced drawdown on the major hydrologic components within each of these hydrographic areas (**Tables 3.2-17 and 3.2-18**). Ground water inflow components consist of recharge, ranch irrigation, ground water inflow across model boundaries, and ground water inflow from the adjacent hydrographic area included in the model domain. Ground water outflow components include evapotranspiration from phreatophyte areas and playas, ground water pumpage at the Phoenix Project and from ranch irrigation wells, outflow across model boundaries, and outflow to the adjacent hydrographic area included in the model domain.

The simulated water balance for the Lower Reese River Valley hydrographic area indicates that the project should have no major change to the water balance components in this area, including outflow to the north to the middle Humboldt River area. For the Buffalo Valley hydrographic area, outflow exceeds inflow when mine dewatering and pumping from the chloride plume well field is occurring. Ground water extracted at the mine results in a reduction of ground water stored in the hydrographic area. The water balance also suggests that during this mining period, pumping at the mine would result in a slight increase in ground water inflow from areas located outside of the model boundary and adjacent to the Buffalo Valley hydrographic area.

3.0 AFFECTED ENVIRONMENT AND ENVIRONMENTAL CONSEQUENCES

**Table 3.2-16
Predicted Drawdown and Recovery of Ground Water Levels at
Ground Water Rights Locations (Proposed Action)**

Map #	Application Number ¹	Permit Status	Use	Model Year 25	Model Year 50	Model Year 150	Model Year 400
				(feet) ¹			
G3	22990	Certificated	Milling	30-50	50-70	30-50	<10
G4	17860	Certificated	Placer Mining	>150	250-300	70-100	~10
G6	24496	Certificated	Domestic	<10	10	30	10-30
G10	44755	Certificated	Stock	10-30	None	None	None
G15	49141	Ready for Action (Protested)	Mining, Milling & Domestic	30-50	50-70	30-50	<10
G16	49142	Ready for Action (Protested)	Mining, Milling & Domestic	30-50	50-70	30-50	<10

¹Numbers indicate the predicted reduction in ground water levels at the water right location, except a plus (+) indicates an increase in ground water levels relative to existing conditions.

Note: Excludes water rights owned or controlled by BMG.

**Table 3.2-17
Simulated Annual Ground Water Budget for the Lower Reese River Valley
Hydrographic Area for Selected Model Years
(Proposed Action)**

Budget Components	Simulated Pre-Development Conditions	Model Year 25	Model Year 50	Model Year 100
	(acre-feet)			
Inflow				
Precipitation Recharge:				
Battle Mountain Area	1,000	1,000	1,000	1,000
Other Recharge	1,200	1,200	1,200	1,200
Ranch Irrigation Recharge	4,200	4,200	4,200	4,200
Ground Water Inflow				
From Southern Boundary	64,000	64,100	63,800	63,800
From Eastern Boundary	2,100	2,200	2,100	2,100
From Northern Boundary	300	300	300	300
From Interbasin Flow	100	0	300	300
Total Inflow	72,900	73,000	72,900	72,900
Outflow				
Evapotranspiration				
Phreatophyte Areas	17,500	17,500	17,500	17,500
Ground Water Outflow				
From Southern Boundary	1,800	1,700	1,900	1,900
From Eastern Boundary	37,200	37,200	37,300	37,300
From Northern Boundary	6,300	6,300	6,300	6,300
From Interbasin Flow	0	400	0	0
Ground Water Pumping:				
Phoenix Project	----	----	----	----
Ranch Pumping	10,000	10,000	10,000	10,000
Total Outflow	72,800	73,100	73,000	73,000
Outflow Minus Inflow	-100	100	100	100

Source: Baker Consultants, Inc. 2000a.

Note: Water balance values presented in the source document were rounded to the nearest hundred for presentation in this EIS.

Table 3.2-18
Simulated Annual Ground Water Budget for the Buffalo Valley Hydrographic Area
for Selected Model Years
(Proposed Action)

Budget Components	Simulated Pre-Development Conditions	Model Year 25	Model Year 50	Model Year 100
	(acre-feet)			
Inflow				
Precipitation Recharge:				
Battle Mountain Area	2,300	2,300	2,100	2,200
Other Recharge	1,100	1,100	1,100	1,100
Ranch Irrigation Recharge	----	----	----	----
Ground Water Inflow				
From North and West Boundaries	16,400	17,400	16,100	16,100
From South and Fish Ck. Mtns.	8,000	9,100	7,600	7,600
From Interbasin Flow	0	800	0	0
Total Inflow	27,800	30,700	26,900	27,000
Outflow				
Evapotranspiration				
Playa Area	16,400	16,400	16,400	16,400
Phreatophyte Areas	9,100	9,200	9,200	9,200
Ground Water Outflow				
From North and West Boundaries	700	100	1,000	1,000
From South and Fish Ck. Mtns.	0	0	0	0
From Interbasin Flow	100	0	300	300
Ground Water Pumping:				
Phoenix Project	1,400	7,000	0	0
Ranch Pumping	----	----	----	----
Total Outflow	27,700	32,700	26,900	26,900
Outflow Minus Inflow	-100	2,000	0	100

Source: Baker Consultants, Inc. 2000a.

Note: Water balance values presented in the source document were rounded to the nearest hundred for presentation in this EIS.

Water Quality Impacts

All mine pits of sufficient depth to reach the ground water table during mining would be backfilled with waste rock to elevations sufficient to prevent the formation of postmining pit lakes. The investigation of water quality impacts has therefore focused on the waste rock, heap leach, and tailings facilities and the ore stockpiles.

Waste Rock Facilities. The Proposed Action is expected to produce approximately 910 million tons of waste rock. Waste rock would be placed in pit backfill facilities and surface-deposited facilities as summarized in **Table 3.2-19**. Waste rock facility locations under the Proposed Action are shown in **Figure 2-4**. **Table 2-2** shows the proposed mining schedule, including the origin and destination for waste rock generated in each year of mine operation.

Design. Waste rock facilities proposed for the Phoenix Project include two types: pit backfill facilities and surface-deposited facilities. Pit backfill facilities would include complete (Iron Canyon, Reona, and Midas pits and the existing Minnie Pit) and partial (Phoenix Pit) backfill designs. Schematic diagrams of pit backfill waste rock facilities are shown in **Figure 3.2-17**. The diagrams indicate the pits where ground water is expected to rebound to levels that would inundate pit backfill after dewatering ceases; this condition is expected in the Phoenix, Reona, and Midas pits, while backfill in the Iron Canyon Pit is expected to remain dry. The Minnie Pit is expected to be dry in the future, although some water accumulation was observed in 1999, and the flow modeling results (Baker Consultants, Inc. 2000a) predict that the pit will fill to a depth of 19 feet. Potentially acid-generating waste rock placed beneath the predicted postmining water table would be

**Table 3.2-19
Waste Rock Facility Tonnages and Average Net Neutralization Potential
(Proposed Action)**

Facility	Waste Rock Volume (million tons)	Average NNP (tons CaCO ₃ /kton)
Pit Backfill Waste Rock Facilities		
Phoenix Pit	120,151	-53
Iron Canyon Pit	4,700	-40
Reona Pit	93,470	-1
Midas Pit – North	70,239	-51
Midas Pit – South	91,119	-59
Minnie Pit	4,824	-73
Subtotal	384,503	
Surface-deposited Waste Rock Facilities		
North Fortitude	5,000	-29
Butte Canyon	1,294	-62
Iron Canyon North	6,709	-50
Iron Canyon South	29,373	-83
Iron Canyon East	25,135	-86
Philadelphia Canyon	44,445	-52
Box Canyon	41,904	-44
Natomas	349,932	-53
Subtotal	503,792	
Ancillary Facilities		
Leach Pad Fill	6,092	-6
Tailings Construction	13,500	-39
Utility Corridor Fill	2,000	-3
Subtotal	21,592	
Total million tons of waste rock/average NNP	909,887	-50

Source: Exponent 2000a; Brown and Caldwell 2000d.

amended with hydrated lime or limestone. Biological amendments may be used as an alternative *or supplement* provided that bench- and field-scale testing demonstrates adequate neutralization and control of potential acid generation and metals mobility. **Backfilled waste rock would be amended up to the model-predicted upper confidence limit of the postmining ground water table. The rate of addition of chemical amendment to the submerged backfill would be calculated to provide sufficient neutralization capacity for all sulfide present in the waste rock that has been predicted to oxidize.** The amended waste rock would be overlain by non-amended waste rock, which would be overlain by 5 feet of capping material (see Section 2.4.18). The cap would be constructed to provide a favorable environment for plant growth, which would increase the fraction of precipitation that is lost to evapotranspiration and therefore is unavailable for infiltration.

Surface-deposited waste rock facilities would be constructed over existing waste rock or copper leach facilities or on undisturbed ground.

Schematic designs for surface-deposited waste rock facilities are presented in **Figure 3.2-18**. Surface-deposited facilities would be constructed in phases, and early phases would be reclaimed concurrent with construction of later phases to minimize the time that waste rock is exposed to atmospheric conditions. As with the pit backfill facilities, 5 feet of capping material would be constructed on all surface-deposited waste rock facilities (see Section 2.4.18).

Site Conditions. The general geologic conditions beneath the waste rock facilities are described in Section 3.1.1.3. Pit backfill facilities and surface-deposited facilities constructed in upland portions of the project area would generally be underlain by bedrock, while facilities constructed in down-valley locations would generally be underlain by alluvium.

The depth to ground water beneath the Proposed Action surface-deposited waste rock facilities would range from approximately 100 to 450 feet (Exponent 2000a, Appendix B4) at the end of mining. The ground water table would be

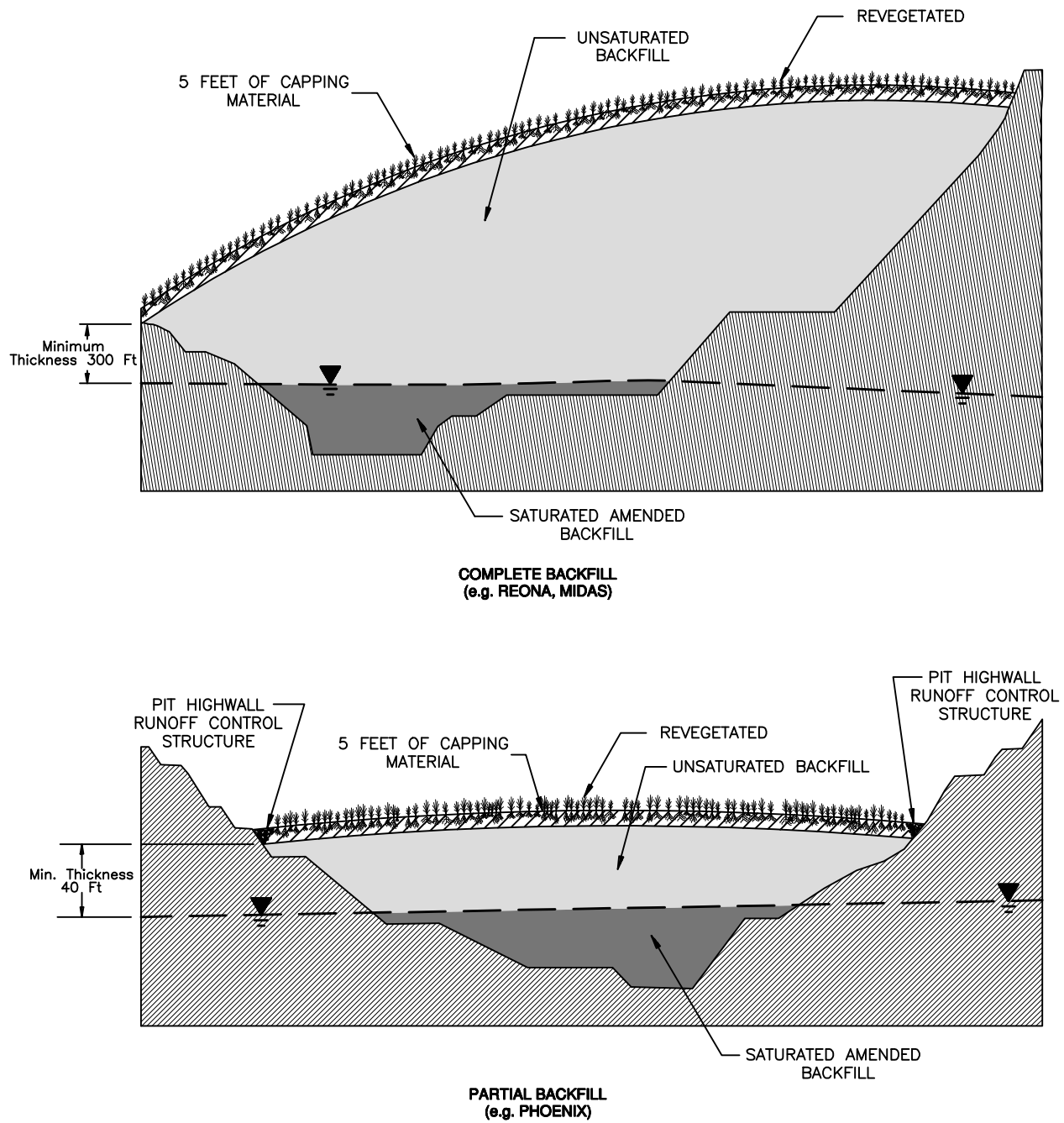

Explanation

▼ Postmining Ground Water Elevation

Source: Brown and Caldwell 2000d

Phoenix Project
Figure 3.2-17
Complete Pit Backfill and Partial Pit Backfill Configurations

Surface Deposition over Existing Waste Rock Facility with Multiple Lifts (Staged)

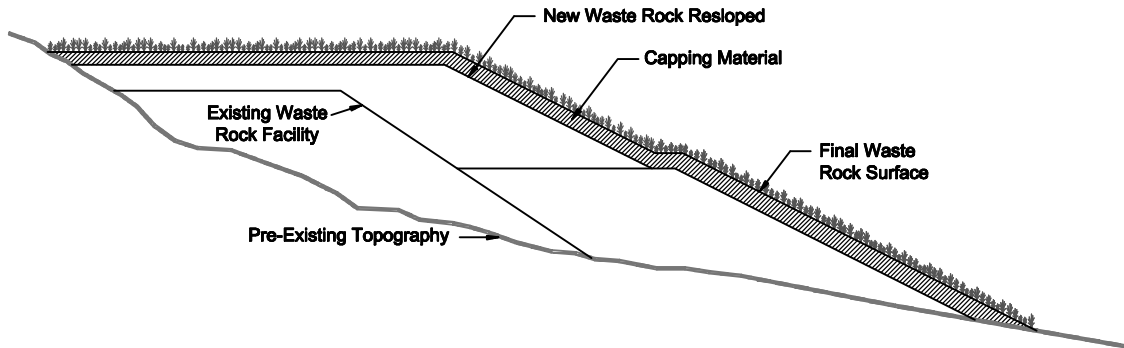

Surface Deposition over Undisturbed Ground with Multiple Lifts and Perimeter Style Construction

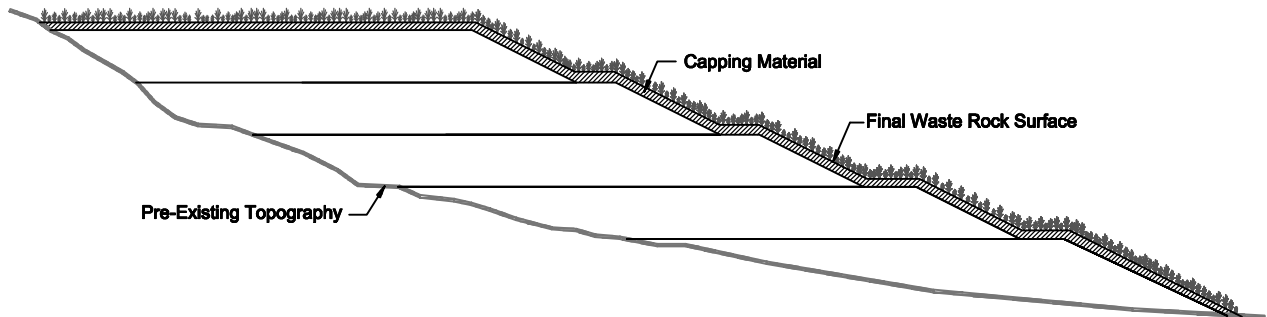

Source: Brown and Caldwell 2000d

Phoenix Project
Figure 3.2-18 Waste Rock Facilities Over Existing Facilities and Undisturbed Ground

depressed beneath the facilities due to the loss of recharge during the period of wetting front migration through the facilities.

Geochemical Characterization and Impacts. Acid-base accounting tests were conducted on 976 spatially distributed samples of rock from the four proposed pits. As discussed in Section 3.2.1.4, no general correlation of net neutralization potential with rock type was observed, so waste rock has been characterized based solely on the net neutralization values. The vast majority of waste rock was found to be net acid-generating, and all waste rock facilities would have average net neutralization potentials less than zero (**Table 3.2-19**). Oxidized waste rock with positive net neutralization potentials would be selectively handled and used to construct caps for each waste rock facility.

Exponent (2000a) modeled the short-term (up to 130 years) and long-term (beyond 130 years) effects of infiltration of acidic leachate on ground water quality beneath the Proposed Action waste rock facilities by combining information on waste rock chemistry, sulfide oxidation rates, and the flux of water both within and beneath the facilities. The predicted sulfate concentrations in ground water at the downgradient edge of each facility are presented in **Table A-4** in Appendix A. No substantial increases in sulfate concentration in ground water beneath the waste rock facilities are predicted for at least 60 years (approximately 32 years after completion of mining). Sulfate concentrations would be highest beneath facilities located in smaller hydrologic basins, which have smaller recharge areas for ground water that flows beneath the facility, and thus less dilution of waste rock seepage. Maximum sulfate concentrations are predicted to occur between 100 and 1,000 years, with concentrations subsequently decreasing, although peak concentrations beneath some facilities may not occur until after 1,000 years.

It is important to note that there is considerable uncertainty associated with long-term predictions of potential impacts to ground water quality resulting from infiltration through the waste rock facilities. Some of the sources of uncertainty include 1) long-term precipitation and evapotranspiration rates, 2) potential changes in moisture storage capacity over time within the waste rock facilities, 3) potential for development of preferential pathways through the waste rock facilities, 4) long-term oxidation rates in the waste rock facility, 5) unsaturated flow rates through the

variable soil and fractured bedrock materials beneath the facilities, and 6) long-term attenuation potential both within the waste rock facilities, in the underlying unsaturated soil and bedrock materials, and within the ground water system. For these reasons, long-term predictions of increased sulfate concentrations in ground water should be viewed as indicators of long-term trends rather than absolute values. In other words, the predictions suggest that without environmental protection, there is a potential for leachate generated within the waste rock facilities to eventually impact ground water quality.

The prediction of impacts to ground water beneath the waste rock facilities focuses primarily on sulfate because it is considered a reliable, direct indicator of the effects from oxidation of waste rock. Sulfate also is among the most conservative (i.e., most mobile in ground water) constituents released from oxidation of waste rock and therefore would provide the earliest indication of effects on ground water quality. Other constituents also would be present with sulfate in the waste rock seepage; qualitative predictions of constituents expected to be present in ground water beneath the Proposed Action waste rock facilities at concentrations above their drinking water standards were provided by Exponent (2000a, Appendix D2) and are summarized in **Table 3.2-20**. These predictions are based on the relative concentrations of sulfate and other constituents in waste rock leachate. In general, when sulfate concentrations exceed several hundred milligrams per liter, other constituents are present at concentrations above their respective standards. The predictions of other constituents do not account for any potential neutralization or attenuation along flow paths.

The Proposed Action includes a Contingent Long-term Groundwater Management Plan (Brown and Caldwell 2000c) to be implemented as part of the project. This plan includes long-term unsaturated zone monitoring of all waste rock facility caps for early detection of water migration through the caps and of seepage migration from the toes of the surface-deposited waste rock facilities. If evidence of seepage infiltration toward ground water were detected, affected ground water would be captured within the project area to prevent migration beyond the site boundary. Captured ground water would be conveyed to a treatment facility where it would be treated by lime precipitation and membrane separation. Clean water streams from the treatment facility would be reinjected to the hydrographic basins in the

3.0 AFFECTED ENVIRONMENT AND ENVIRONMENTAL CONSEQUENCES

**Table 3.2-20
Constituents Predicted to Exceed Drinking Water Standards
in Ground Water Beneath Waste Rock Facilities**

Constituent	Number of Waste Rock Facilities or Facility Clusters with Concentrations Predicted to Exceed Drinking Water Standard in Ground Water	
	Proposed Action	No Action Alternative
Aluminum	19 of 19	11 of 11
Antimony	19 of 19	11 of 11
Arsenic	19 of 19	11 of 11
Barium	13 of 19	9 of 11
Beryllium	19 of 19	11 of 11
Cadmium	19 of 19	11 of 11
Chromium	12 of 19	9 of 11
Copper	19 of 19	11 of 11
Fluoride	17 of 19	9 of 11
Iron	19 of 19	11 of 11
Lead	19 of 19	11 of 11
Magnesium	13 of 19	9 of 11
Manganese	19 of 19	11 of 11
Mercury	19 of 19	10 of 11
Nickel	19 of 19	11 of 11
Selenium	17 of 19	9 of 11
Silver	5 of 19	4 of 11
Sulfate	19 of 19	10 of 11
Thallium	19 of 19	10 of 11
Zinc	19 of 19	11 of 11

Note: Based on Tables 1 and 2, Appendix D2, Exponent (2000a).

proportions in which the water was withdrawn to minimize any effects on water quantity in the various basins. Any remnant water treatment streams with high constituent concentrations would be evaporated. Any resultant sludge would be stabilized or solidified and disposed of in a sludge disposal cell located between the Natomas Waste Rock Facility and the Heap Leach Facility. As stated in Chapter 1.0, the BLM will determine the amount of surety bond necessary to fund the contingent ground water recovery and treatment activities included in the Proposed Action.

Impacts to ground water quality from leachate infiltration would be limited to areas upgradient of the ground water capture well transects specified in the Contingent Long-term Groundwater Management Plan (Brown and Caldwell 2000c). Proper monitoring, capture and treatment of any impacted ground water would prevent degradation of ground water downgradient of the collection system. Therefore, significant impacts to ground water downgradient of the collection system are not anticipated.

Impacts to ground water due to fluctuations of the ground water table within backfilled pits are not expected because the pit backfill would be amended up to the model-predicted upper confidence limit of the postmining ground water table. In addition, the amendment rate would be calculated to provide neutralization for all sulfide present in the backfilled waste rock that has been predicted to oxidize. If unexpected ground water quality impacts occur due to fluctuation of postrecovery ground water levels beyond the amended backfill, the Contingent Long-term Groundwater Management Plan (Brown and Caldwell 2000c) would provide for the capture of affected ground water near the backfilled pits.

The water quality impact due to runoff from reclaimed waste rock facilities is expected to be minimal based on MWMP testing. Some transient impacts to runoff water quality may occur when precipitation comes in contact with sulfidic waste rock in the waste rock facilities during construction and prior to capping or in ore stockpiles prior to processing. Runoff water affected by sulfide oxidation products would be captured and

managed in compliance with the Post-Reclamation Conceptual Storm Water Management Design (Brown and Caldwell 2000f). Therefore, no offsite impacts to surface water quality from runoff are expected.

Heap Leach Facilities.

Design and Site Conditions. The heap leach pad site is underlain by quaternary alluvium. The heap leach pad is designed to accommodate approximately 48.3 million tons of ore. The pad would be an expansion of the existing heap leach pad; the expansion design includes an 80-mil liner with a silt bed and leak detection system under the liner. An additional event pond would also be constructed with a primary 60-mil liner high-density polyethylene liner and secondary geomembrane liner, with a leak detection system beneath the primary liner. All beneficiation facilities would be contained to prevent releases to surrounding soils. Further design details are included in Section 2.4.13.

Impacts. The heap leach facility is designed to operate as a lined zero-discharge facility. Monitoring would be conducted during operation and closure to verify that no releases have occurred. No impacts to water quality are expected from heap leach operations.

Tailings Facilities.

Design. Tailing Areas #1, #2, and #3 would be constructed in part over the existing inactive tailings area. If additional tailings capacity is required during the life of the project, an additional tailings facility would be constructed in the South Optional Use Area. The facilities would include a basal low-permeability soil barrier overlain by a geomembrane liner. An underdrain system would be placed over the liner to enhance tailings dewatering. Additional details of the tailings facility design are presented in Section 2.4.12.

Site Conditions. Tailings Areas #1 and #2 would be constructed, in part, over existing copper tailings material; Tailings Area #3 would be constructed, in part, over existing gold tailings material. The existing copper and gold tailings are situated over alluvial sediments. Alluvial sediments also underlie the tailings facility that may be constructed in the South Optional Use area. The alluvial sediments generally consist of unconsolidated sands and gravels with minor amounts of silts and cobbles (Golder 2000a). The depth to ground water in the area of the proposed

tailings facilities ranges from approximately 100 to 300 feet below the ground surface, and the aquifer is considered highly transmissive (Golder 2000a).

Impacts. Humidity cell (kinetic) testing was performed on 12 flotation tailings composites produced from a mill pilot plant. These tests are believed to be representative of some of the tailings material that would be deposited within the tailings facilities. The humidity cell tests were performed to determine the potential of the solids to generate acid and release constituents of concern under simulated natural weathering and oxidizing conditions. The humidity cell testing procedures and results of water quality testing are presented in McClelland Laboratories, Inc. (2000a) and are summarized in the following paragraphs.

These humidity cell tests were conducted for a period of 23 weeks. The results of the testing indicated that 9 of the 12 composite samples had extract pHs generally below 3. These tests indicated that these 9 composite samples displayed a potential to generate acid in a natural weathering and oxidizing environment. The remaining three composite samples displayed a potential to neutralize rather than generate acid in a weathering environment.

Tailings materials that generate acid are a concern, since they tend to mobilize metals and other constituents of concern that may be present within these materials. The humidity cell tests confirmed that the nine tailings composite samples with acid-generating potential also exhibited a potential to mobilize metals. One or more of the acid-generating samples had concentrations of arsenic, beryllium, cadmium, chromium, copper, lead, mercury, nickel, and selenium that exceeded primary drinking water standards (also known as Maximum Contaminant Levels or MCLs) and concentrations of aluminum, fluoride, iron, manganese, sulfate, and total dissolved solids that exceeded the secondary drinking water standards. The three tailings samples that exhibited an acid-neutralizing potential did not mobilize any constituents above the primary drinking water standards, but one or more of these samples released iron, manganese, sulfate and total dissolved solids in concentrations above the secondary drinking water standards.

A lined pond was used during the pilot plant operation to collect tailings pulp generated during the operation and to provide recycled water for the pilot plant. Samples of the tailings supernatant pond water were collected three times over the

3.0 AFFECTED ENVIRONMENT AND ENVIRONMENTAL CONSEQUENCES

30-day pilot plant operational period (Lakefield Research 1999). The results of the test provide a preliminary indication of the quality of the supernatant fluids that would likely be ponded in the tailings facilities. The pH of the pond water ranged from 5.45 at day 0, to 5.83 at day 15 to 7.39 at day 30. The pond water also contained concentrations of cadmium, sulfate, total dissolved solids, and zinc that were above the drinking water standards in at least one sample event.

In summary, the results of the mill pilot plant tests suggest that some of the tailings materials may be net acid-generating. In addition, without chemical additives to adjust the pH, water ponded on the tailings facilities could at times be acidic and contain elevated metal concentrations. The potential impacts to waterfowl or other wildlife that may come in contact with solutions ponding on the tailings facilities are addressed in Section 3.5.2.

Operation and closure of the tailings facilities are not anticipated to have a significant impact to surface or ground water quality outside the facility because the facilities would be designed and constructed for containment in accordance with NAC 445A.437, 445A.437, and 445A.438 to prevent discharge.

Ore Stockpiles. Three existing ore stockpiles (Fortitude, Tomboy, and Northeast Extension) are present at the site. These stockpiles would be processed at the mill and leach facilities in years 4 and 5 of the proposed project. No ore stockpiles would remain at the end of the Phoenix Project. Rain or snowmelt that comes in contact with these materials prior to processing could mobilize oxidation products from these sulfidic materials. The MWMP is the test most commonly used to characterize contact of rocks at the ground surface with rain or snowmelt water. The MWMP was used to test neutral oxide rocks to be used in cap construction for the Phoenix Project. The best indication of the probable chemistry of meteoric water after contact with ore stockpile material is the kinetic humidity cell tests described in Section 3.2.1.4. The ore stockpile materials generally have negative net neutralization potential and could contribute acid, sulfate, and metals to runoff water or to water infiltrating to underlying materials during the mining period prior to closure. However, runoff water affected by sulfide oxidation products would be captured and managed in accordance with the Storm Water Pollution Prevention Plan (Brown and Caldwell 2000g) as discussed below. Therefore, impacts associated with surface water runoff are not anticipated. Processing of these existing stockpiles also would eliminate these

stockpiles as a potential source of long-term ground water contamination.

Storm Water Management

Design. Storm water runoff from the existing project site has been controlled in accordance with state and federal regulations pertaining to storm water management and pollution prevention, as described in Section 3.2.1. BMG has prepared five primary documents (or document sections) for the proposed project to address control of storm events and site runoff. These documents formulate the on-site water management program in accordance with agency planning and permitting requirements. Drainage controls would be implemented during and after the proposed project in accordance with these documents, which are available for public review and are incorporated by reference into this impact assessment. They include:

- Application for Major Modification of Water Pollution Control Permit NEV87061 (Brown and Caldwell 1999a)
- Phoenix Project Storm Water Pollution Prevention Plan (Brown and Caldwell 2000g)
- Phoenix Project Revised Plan of Operations, Reclamation Plan (Brown and Caldwell 2000h)
- Phoenix Project Waste Rock Management Plan (Brown and Caldwell 2000d)
- Phoenix Project Post-Reclamation Conceptual Storm Water Management Design (Brown and Caldwell 2000f)

The Water Pollution Control Permit addresses the engineering design of control technologies to protect the waters of the State in accordance with Nevada Administrative Code 445A.397. This permit application includes a meteorological and water resources inventory, presents the design of project components to control storm runoff and manage process fluids used in beneficiation, and describes leak detection systems and site monitoring. Process fluid containment at the mill and ancillary facilities, heap leach, and tailings facilities are major features of the permit application. Meeting these requirements would be accomplished by the application of solution collection systems and control technologies such as engineered liners, pipelines, valves and sumps, event ponds, and containment berms. The commitments and approaches for tailings

neutralization, stabilization of heap leach materials, materials management (including waste rock), storm water pollution prevention, monitoring and closure are included in the permit application sections, and meet or exceed state requirements. With regard to storm water management, key requirements of the permit are outlined below.

- All process components would be designed to withstand the runoff from a 24-hour storm event with a 100-year recurrence interval. This includes design of diversion ditches, pipelines, and tailings impoundments.
- The primary fluid management system would be designed to remain fully functional and fully contain all process fluids including all accumulations resulting from a 24-hour storm event with a 25-year recurrence interval. This requirement includes heap draindown from a 24-hour power outage, 110 percent draindown of the largest solution tank, and two feet of freeboard.

The Phoenix Project Storm Water Pollution Prevention Plan (Brown and Caldwell 2000g) and the Phoenix Project Post-Reclamation Conceptual Storm Water Management Design (Brown and Caldwell 2000f) address storm water management over the entire proposed disturbed area and adjacent lands, as well as potential discharges to waters of the U.S. ***All storm water management and associated permit compliance would be coordinated with the Nevada Bureau of Water Pollution Control and would comply with the provisions of the State of Nevada General Discharge Permit No. GNV 0022225.***

The Storm Water Prevention Plan defines drainage design and best management practices for the proposed action over a 5-year timeframe in accordance with current permit requirements from NDEP. This plan will be periodically updated as needed, and contains summary descriptions and diagrams of the conceptual phased storm water management program throughout project operations. An extensive system of diversion ditches, pipelines, and retention basins are proposed to manage storm runoff from the project area. In addition, best management practices are identified to control erosion, and sedimentation, maintain personnel training, handle materials, respond to spills, and conduct periodic inspections and maintenance.

Storm water drainage controls include retention ponds at the base of proposed waste rock facilities

in the Butte Canyon, Iron Canyon, and Philadelphia Canyon drainages. The existing system of collection, piped conveyances, and collection ponds (surge pond and overflow pond) present in Iron Canyon would remain in place or be modified as needed during the Proposed Action. Collected storm water in Iron Canyon would be managed according to a variety of approved methods. These may include evaporation, industrial beneficial use, and/or water treatment to an applicable standard or beneficial use (e.g., agriculture). Any treated water not put to beneficial use would be discharged at a location downgradient and/or without a connection to waters of the U. S. (Brown and Caldwell 2000g). The existing Philadelphia Canyon system for collection, piped conveyance, and the evaporation/surge pond also would be maintained and/or modified, as necessary (Brown and Caldwell 2000g). The Copper Canyon evaporative pond would serve as a source of make-up water or would be conveyed via the current double-lined piping system to the heap leach pad or the tailings pond. The tailings facilities have been designed to retain runoff contributions from the 100-year, 24-hour storm event during project operations. Storm water runoff would be diverted around the pits, and any runoff originating within pit areas would be pumped from pit floor sumps for use as make-up water in the beneficiation facilities.

An important feature of storm water pollution prevention for the site is the collection, monitoring and potential treatment and/or re-use of surface water runoff that comes into contact with waste rock or pit backfill materials. An acidic runoff event occurred from the Iron Canyon waste rock facility in the spring of 1998 (Brown and Caldwell 1998c). This event was produced by the rapid melt of accumulated snow under substantial rainfall in late March of that year. Although they occur less frequently in comparison to other runoff events, rain-on-snow events such as this can produce much higher runoff volumes and flow magnitudes than other storm types more common in the Basin and Range. Acidic runoff (pH 3.0 to 3.5 in some water samples) was produced from the Iron Canyon event, and metals content also exceeded drinking water criteria in several samples. Subsequent studies indicated that storm water infiltrating into the waste rock may have encountered near-surface preferential flow paths that contributed to the affected runoff (Brown and Caldwell 1998c).

BMG responded to the situation with an interim collection, monitoring, and treatment program that

3.0 AFFECTED ENVIRONMENT AND ENVIRONMENTAL CONSEQUENCES

included a PVC pipe collection network and a portable lime-precipitation treatment plant. During the same general timeframe, it was discovered that acidic runoff was being produced at the toe of a waste rock facility at the head of Butte Canyon (Brown and Caldwell 1998c). The collection system was expanded to capture this water and convey it to the Iron Canyon treatment facility. Further monitoring indicated that no adverse impact to Galena Creek occurred from the discharge of treated storm water runoff (Brown and Caldwell 1998c). The interim treatment facility has been converted to a permanent operation involving an approximately 6.4-million-gallon surge pond at the mouth of Galena Canyon. Under the Proposed Action, **storm water management would entail operational makeup use, evaporation, and/or treatment to an appropriate beneficial use standard (e.g., relevant to agriculture). As necessary, treated storm water effluent would then be used for irrigation of downgradient cropland.** Monitoring would continue throughout operations and until reclamation has been deemed successful.

The storm water systems for the current project and the long-term postreclamation condition are designed to accommodate more severe events than those that occurred at Iron Canyon in 1998 (Brown and Caldwell 2000f,g). Any additional water management necessary in the Iron Canyon/Butte Canyon area would be conducted using approved methods (including operational makeup use, evaporation, and/or water treatment). Given the monitoring provisions and the large seasonal capacity of that system (based on the spring/summer 1998 runoff conditions), adequate storage volume should be present to allow periodic treatment, if needed. In addition, recontouring and revegetation during the reclamation period would substantially reduce the amount of runoff originating from the disturbed areas.

Impacts. Implications for the Proposed Action are that similar events may occur at other waste rock facilities. Results of baseline hydrochemical analyses conducted by Exponent (2000a) indicate that a substantial portion of the project waste rock is potentially acid-generating, and that uncapped sulfide waste rock would be subject to oxidative weathering. As a result, surface water runoff from such exposed materials is predicted to be acidic and contain elevated levels of sulfate and dissolved metals. Proposed concurrent reclamation practices that promote the timely

covering of acid-generating waste rock with capping material will help to minimize the risk of acidic surface runoff (Brown and Caldwell 1998c). In addition to best management practices to manage storm water quantity, storm water controls would be designed in operational areas to collect runoff for evaporation, infiltration, and/or temporary treatment, as necessary. Storm water controls would be monitored pursuant to the General Storm Water Permit conditions (Brown and Caldwell 1999a). In addition, monitoring within the cap materials and at the toes of waste rock facilities would provide additional means of identifying and controlling potential runoff impacts.

Given the commitment to meet or exceed state and federal requirements for controlling and monitoring storm runoff in the proposed project area and adjacent lands, no impacts to surface waters from runoff events are anticipated during the initial operational phases covered by the Storm Water Pollution Prevention Plan and the Water Pollution Control Permit.

The Phoenix Project Post-Reclamation Conceptual Storm Water Management Design (Brown and Caldwell 2000f) identifies a conceptual approach for management of surface water during and after the reclamation period, until the site has been stabilized and closed in accordance with NDEP and BLM regulations, guidelines, and proposed site-specific monitoring programs. During final reclamation of the Proposed Action components, a system of open-channel conveyance structures and sediment basins would be constructed to safely collect and convey storm runoff away from the reclaimed project area. Where possible, a buffer zone of native material would be maintained between the conveyance structures and reclaimed surfaces. Soil liners would be used beneath the diversions if they pass over backfilled mine pits.

Postmining diversion and retention structures would be designed to safely convey and retain runoff from the 100-year, 24-hour storm event. Detailed hydrologic and hydraulic modeling using standard industry procedures has been conducted to identify preliminary structure designs. The locations of conveyance structures and a typical cross section are shown in **Figures 3.2-19 and 3.2-20**, respectively. The location of sediment and flood peak retention basins and a typical design are shown in **Figures 3.2-19 and 3.2-21**, respectively. All structures would be reinforced where needed with stone riprap. Overflow from the sediment basins would be discharged through

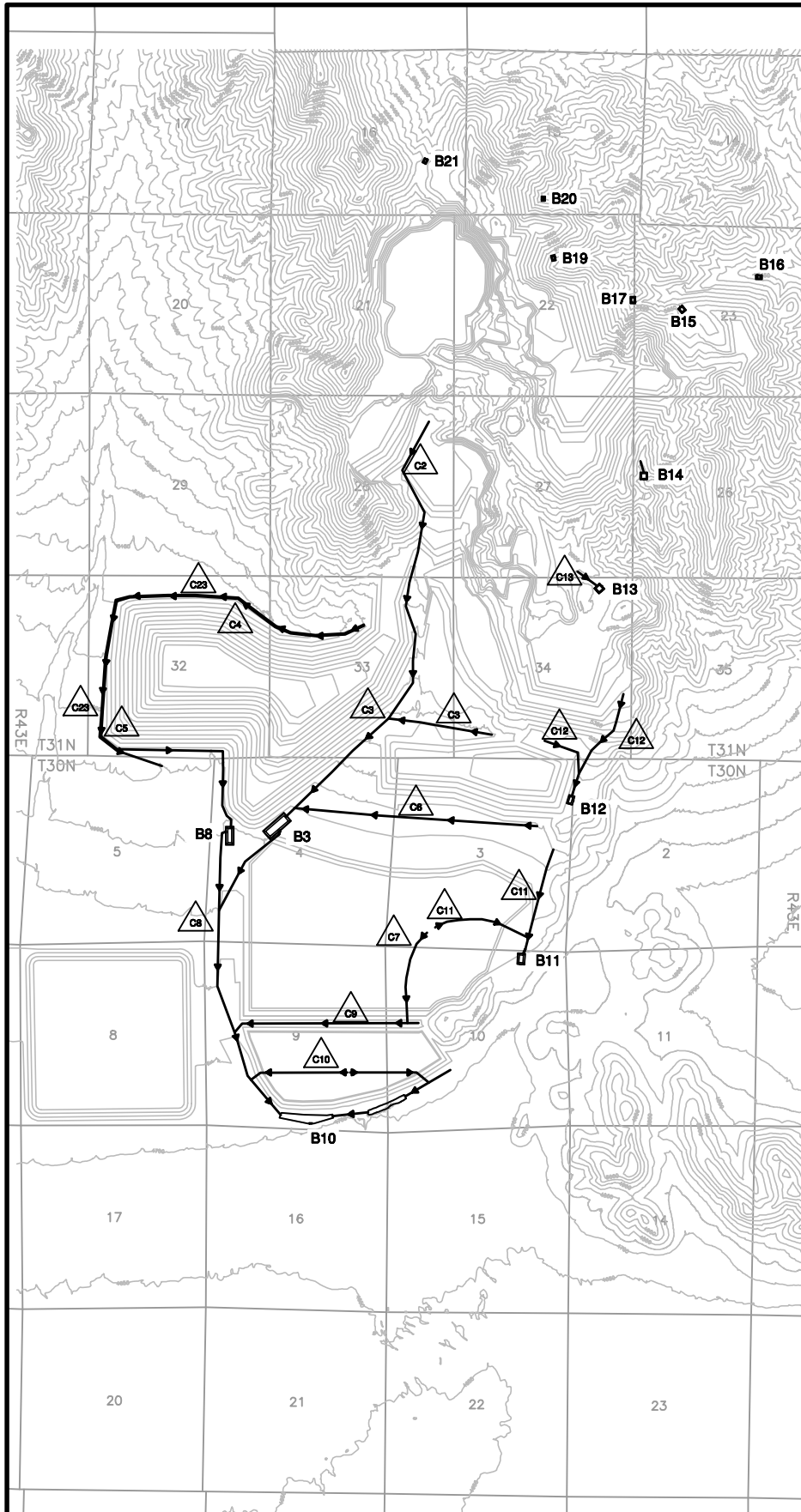

- Explanation**
- Diversion Channel
 - △ C11 Diversion Channel Label
 - B15 Sediment Basin

Source: Brown and Caldwell 2000f

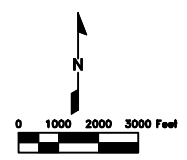

Phoenix Project
Figure 3.2-19
Postreclamation
Storm Water
Management Design
(Proposed Action)

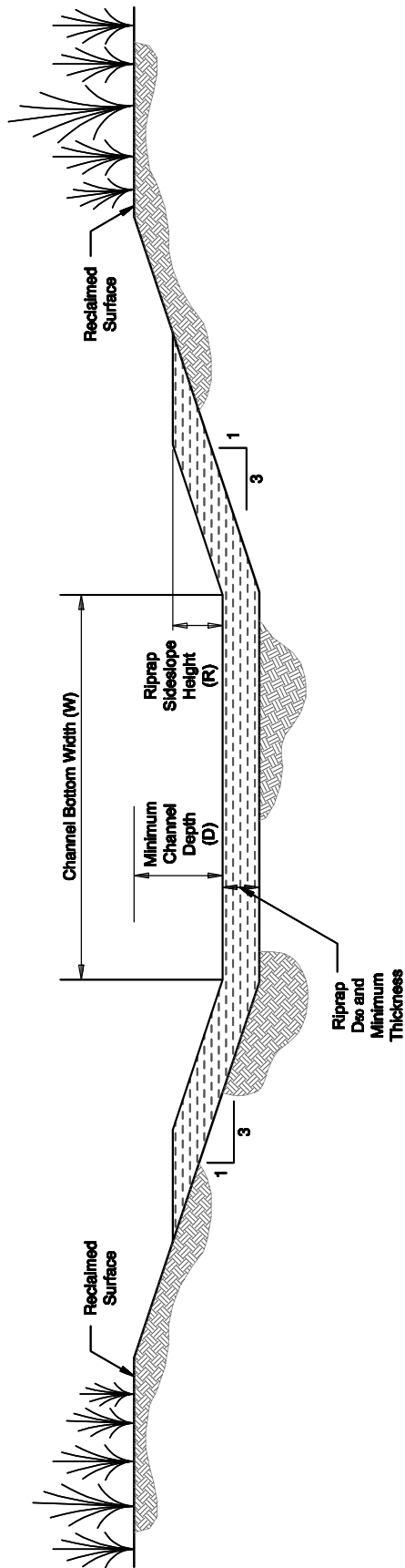

Channel Section	Channel Bottom Width (W)	Minimum Channel Depth (D)	Riprap Side Slope Height (R)	Riprap D ₅₀	Riprap Thickness
Typical	20'	2.9'	1.2'	12"	15"
	20'	3.7'	1.3'	12"	15"
	16'	1.5'	0.7'	3"	4.5"
	16'	2.2'	1.1'	3"	4.5"
	8'	1.8'	0.8'	1.5"	3"
	16'	2.1'	0.2'	1"	3"
	4'	1.1'	0.3'	1.5"	3"

Source: Brown and Caldwell 2000f

Phoenix Project

Figure 3.2-20

Typical Diversion Channel Section

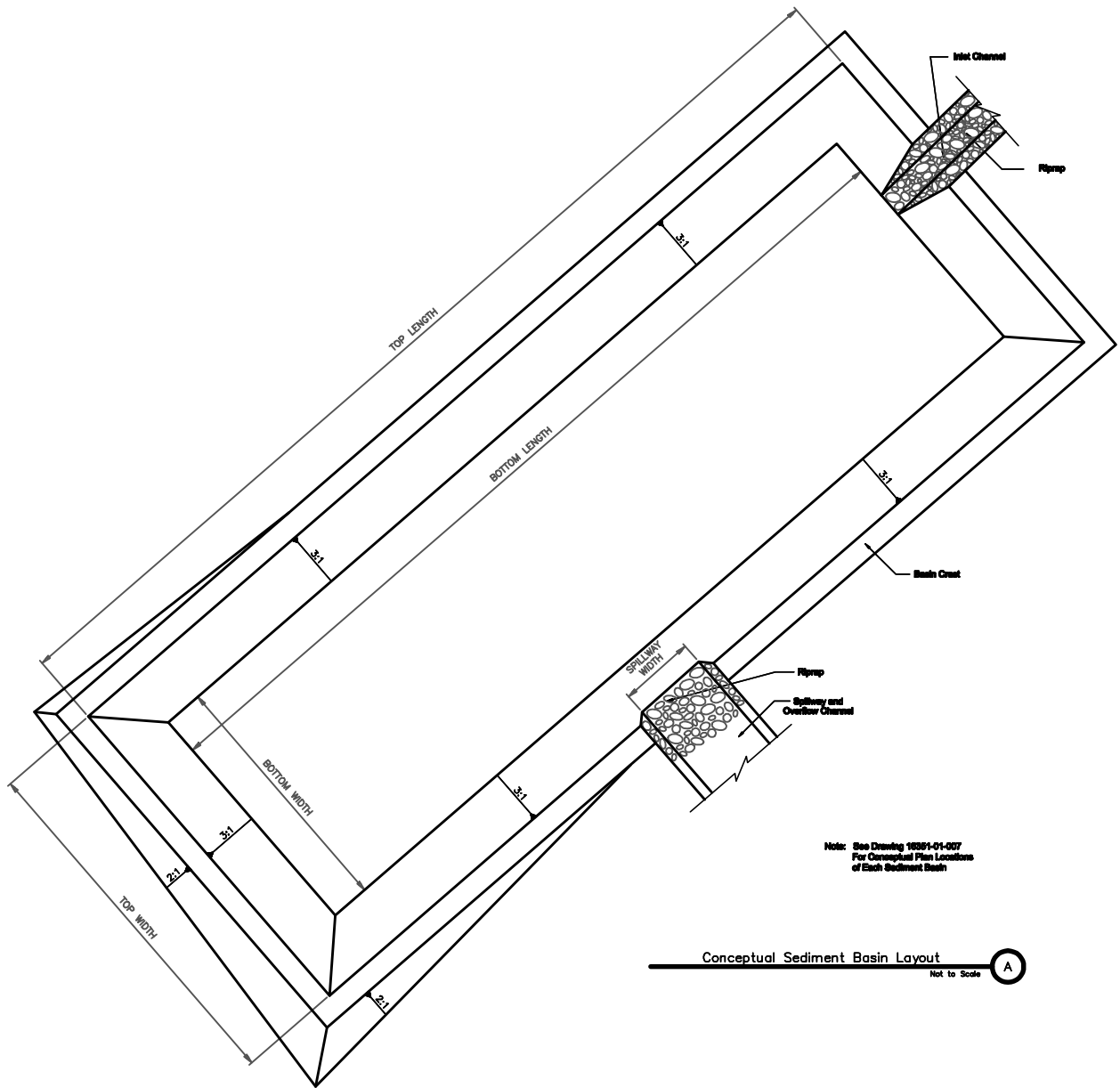

Note: See Drawing 16351-01-037
For Conceptual Plan Locations
of Each Sediment Basin

Conceptual Sediment Basin Layout

Not to Scale

A

Sediment Basin	Bottom Width (Feet)	Bottom Length (Feet)	Top Width (Feet)	Top Length (Feet)	Total Basin Depth (Feet)	Depth of Spillway (Feet)	Spillway Width (Feet)	Storage Capacity (Acres Feet)
B3	202	700	282	790	15	2	60	53.2
B8	115	410	205	500	15	2	50	20.7
B10	-	-	-	-	8	2	80	25.9
B11	120	220	210	310	15	2	16	12.4
B12	84	180	174	270	15	2	20	8.2
B13	145	145	205	205	10	2	16	5.3
B14	140	140	188	188	8	2	21	5.0
B15	90	110	160	170	10	2	10	2.8
B16	55	115	115	175	10	2	6	2.0
B17	75	130	135	190	10	2	10	2.8
B19	50	95	110	155	10	2	10	1.8
B20	40	70	100	130	10	2	10	1.1
B21	50	80	110	140	10	2	10	1.4

Phoenix Project

Figure 3.2-21

Conceptual Sediment
Basin Layout

Source: Brown and Caldwell 2000f

3.0 AFFECTED ENVIRONMENT AND ENVIRONMENTAL CONSEQUENCES

reinforced overflow spillways into existing drainages. Runoff water quantity and quality monitoring would occur at 14 new locations adjacent to project components, and at approximately 25 previous monitoring sites for streams and springs within the study area. Surface water monitoring is further described in the Water Pollution Control Permit Application (Brown and Caldwell 1999a) and in the Water Resources Monitoring Plan (Brown and Caldwell 2000e). Surface runoff that is acidic and/or carrying excessive metals concentrations is not expected to occur after the waste rock facilities have been capped and revegetated. Contingency monitoring and appropriate management responses (including treatment if necessary) are being proposed for the waste rock facilities. Soil moisture measurements and suction lysimeter sampling are among the techniques proposed. These provisions are described in greater detail in the Phoenix Project Contingent Long-term Groundwater Management Plan (Brown and Caldwell 2000c).

After reclamation and revegetation have been deemed successful and the site has been stabilized, the long-term storm water control structures would gradually fail. Over time, runoff and drainage functions would mimic those of nearby natural watersheds. A freely draining topography would be restored to the project components (including the tailings impoundment and other process or event ponds) and to the overall storm water management system. Some additional erosion and sediment transport would occur during this unknown period of structural adjustment until a watershed equilibrium has been reached. These conditions are not anticipated to pose significant risk or potential impacts to the drainage systems.

Life-of-project and long-term post-project storm water control, containment, and monitoring are addressed in the Stormwater Pollution Prevention Plan (Brown and Caldwell 2000g) and the Post-Reclamation Conceptual Stormwater Management Design (Brown and Caldwell 2000f). Current and long-term system design would accommodate a 100-year, 24-hour rainfall (2.60 inches), which is substantially greater than that observed during the seasonal events of 1998.

Control of the common potential sources of storm water pollution are addressed in the plans and permit documents discussed previously in this section. In addition, some

waste rock materials used for construction (e.g., haul roads, pads) and older waste rock exposed during grading could generate acid rock drainage and affect surface water quality. Mitigation measure WR-10 (Section 3.2.4) provides measures to minimize potential impacts from these sources.

With this mitigation and the commitment to meet or exceed state and federal requirements for controlling and monitoring storm runoff in the proposed project area and adjacent lands, in addition to the long-term contingent monitoring and management plan, no other significant impacts to surface waters from runoff events are anticipated during the operations and reclamation phases of the Proposed Action.

Watershed Yield and Erosion, Sedimentation, and Flooding Impacts. Most of the surface runoff from higher elevations in the region is lost to evapotranspiration or channel seepage into deep alluvial deposits; this water loss also is typical of surface water yields from the project area. In addition, channel flows historically contributed by project area drainages have varied due to inconsistent seasonal precipitation and the history of disturbance at the site. Other factors that have caused variations in surface water yield among the drainages are elevation and physiography, geology and soil characteristics, vegetation, and human land uses.

As discussed in Section 3.2.1, JBR (1996d,g) and Baker Consultants, Inc. (1997a) have conducted stream flow monitoring in the study area. The flow data gathered during this monitoring program (**Table 3.2-21**) provides a general indication of the seasonal watershed yield for various sub-basins in or near the study area. These estimates assume that the stream flow measurements represented average conditions for the quarter in which they were made. The actual watershed yields may vary based on measurement frequency or from other considerations described above.

During early June 1996, additional measurements were taken along Willow Creek below the reservoirs (Baker Consultants, Inc. 1997a). These measurements showed substantial flow variation with increasing watershed area in the upper reaches of the creek, and decreasing surface water yields along lower Willow Creek where the mountain front gives way to the alluvial fan system.

**Table 3.2-21
General Surface Water Yields**

Sample Site	Stream	Cumulative Drainage Area (acres)	Elevation Range (feet, amsl)	Fall 1995 Yield (inches)	Spring 1996 Yield (inches)	Summer 1996 Yield (inches)	Fall 1996 Yield (inches)
31-43-23-21	Iron Canyon Re-emergence	663	5,500 to 7,000	n/a	0.18	0	0
31-43-14-41	Butte Canyon	447	5,400 to 6,880	n/a	0.33	0	0
31-43-24-11	Galena Canyon	4,207	5,240 to 7,760	n/a	0.48	0	0
32-43-32-43	Upper Willow Creek	1,351	6,500 to 8,230	0.20	2.35	0.75	0.74
32-43-5-34	Upper Willow Creek	2,724	5,960 to 7,830	0.61	2.41	0.44	0.43
31-43-8-33	Upper Willow Creek	3,376	5,740 to 7,080	0.92	2.57	0.41	0.38

Flow Data Source: JBR 1996d and Baker Consultants, Inc. 1997a.
n/a: data not available.

Overall, these data indicate substantial variation between basins, and within a given basin from year to year or season to season. Higher surface water yields are evident in the early spring and summer, with decreasing or no surface water yields in the later summer and fall. In addition, basin elevation and seasonal precipitation affect the surface water yield.

Aside from the spring runoff period, Willow Creek data show increasing discharges with increasing drainage area in the fall of 1995 and spring of 1996, but decreasing yields with greater drainage area in the summer and fall of 1996. These differences are probably due to changes in the timing and distribution of precipitation and snowmelt, as well as the effects of other conditions such as near-surface ground water flows. Although the available data are sparse, substantial variations in surface water yields are indicated for the study area.

Table 3.2-22 presents the estimated changes in surface water yield resulting from topographic modifications that would occur under the Proposed Action. These topographic changes would generally prohibit drainage areas from contributing to surface water yields during operations, and in some cases after reclamation and closure. Under the long-term post-reclamation conceptual storm water management design for the Proposed Action, storm water would be routed off the reclaimed tailings site and be allowed to drain to the alluvial fan system (Brown and Caldwell 2000g). This represents a change from the existing conditions.

In addition to these potential yield modifications, the stream flow monitoring data comparison between Iron and Butte canyons suggests that there are further yield losses associated with the overall occurrence of mining disturbance in the watershed. This may be partly explained by existing storm water diversions and controls, which would be expanded during the Proposed Action. A system of sediment ponds and control basins would be employed throughout the project area during operations, which would cause further yield reductions from those shown in **Table 3.2-22**. The actual total reduction is unknown due to the uncertainty of channel and pond seepages in the storm water drainage network and drainage restoration from concurrent reclamation practices.

However, it is likely that short-term reductions in seasonal runoff in ephemeral drainages would result in reduced surface water yield from the project area. However, considering that most of the seasonal runoff is lost to evaporation or contributes to ground water recharge, these potential reductions in surface water yield are not anticipated to have a significant impact on surface water resources in the hydrologic study area. Potential impacts to wildlife habitat associated with these localized reductions in surface water runoff are discussed in Section 3.5, Wildlife Resources. The net surface water yields are expected to return to conditions that are approximately equivalent to existing conditions (**Table 3.2-22**). Therefore, no significant long-term reduction in surface water yield is anticipated.

3.0 AFFECTED ENVIRONMENT AND ENVIRONMENTAL CONSEQUENCES

**Table 3.2-22
Comparison of Surface Water Yields for Existing Conditions and Proposed Action**

Proposed Project Facility	Net Contributing Area Change² During Proposed Operations (acres)	Yield Change² During Proposed Operations (acre-feet /year)	Net Contributing Area Change² After Proposed Reclamation (acres)	Yield Change² After Proposed Reclamation (acre-feet /year)
Pit Highwalls and Backfills	-856.7	-70.7	-449.4	-37.1
Stockpiles	-16.2	-1.3	0	0
Waste Rock Facilities ¹	-1,060.5	-87.5	0	0
Tailings Facilities	-611.4	-50.4	1,396.1	115.2
Heap Leach	-360.4	-29.7	0	0
Old Mill Area	38.4	3.2	0	0
New Mill Area	-30.7	-2.5	0	0
Ancillary Facilities	-11.2	-0.9	0	0
TOTAL	-1,848.2	-239.8	946.7	78.1

¹It is assumed that waste rock facilities would not directly drain from the proposed project area, and that prior to reclamation, much of the runoff from these areas would be retained in sediment basins or lost to evaporation and seepage.

²Negative changes indicate that losses would occur; positive changes indicate that gains would occur as existing facilities are reclaimed and site drainage restored.

Overall, erosion and sediment yields from the project area are not expected to increase substantially, due to implementation of the storm water pollution prevention program, which includes provisions for erosion and sedimentation control, and because of concurrent and post-mining reclamation. BMG has demonstrated success with its reclamation and revegetation approaches at the Copper Basin site nearby and proposes similar practices at the Phoenix Project. The postmining reclamation surface is anticipated to have a coarse, relatively non-erosive grain size distribution that would limit erosion rates on project components. Additional discussion of this topic is presented in Soils and Reclamation, Section 3.3.

3.2.2.2 No Action Alternative

Water Quantity Impacts

Pit Dewatering and Water Management. As described in Section 2.3, the No Action alternative consists of the continued operation and the closure and reclamation of the currently permitted Reona Project. The timing and duration of any additional mining and ore processing under the No Action alternative would depend on economic conditions. Estimates of drawdown and recovery under the No Action alternative were based on the following assumptions (Baker Consultants, Inc., 2000a):

- 1) No additional pit dewatering would occur.
- 2) Pits would not be backfilled, and pit lakes would be allowed to develop.

- 3) Pumping would continue at extraction well CM-1, and commence at new extraction wells CCPW-1 and CCPW-2 at a combined rate of approximately 2,000 gpm for an estimated 10 years to mitigate the chloride plume near the tailings facility.
- 4) Pumping would continue at extraction wells PW-1, PW-2A, PW-4, and CM-1 to provide clean water for reclamation and other mine uses.

The assumed ground water extraction rates used to simulate ground water drawdown and recovery under the No Action alternative are presented in **Table 3.2-23**. Water extracted from the chloride plume and the clean water well field would be used for makeup water for the heap leach, reclamation, and dust suppression activities.

Impacts to Ground Water Levels. As for the Proposed Action, the area that is predicted to experience a change in ground water elevation of 10 feet or more from mine dewatering and water management activities was selected as the area of potential concern for impacts to water resources. Changes in water levels (drawdown and recovery) represent the difference between the model-simulated ground water elevations at representative future points in time and the baseline ground water elevations that existed in June 1996. Model year 1 is the first year of the No Action alternative, and model year 11 is the year that ground water extraction would cease (**Table 3.2-24**).

Table 3.2-23
Estimated Pit Dewatering and Well Field Production Rates
(No Action Alternative)

Model Year	Pit Dewatering	Production Wells		
		Well Field (gpm)	Chloride Mitigation Well Field (gpm)	Total All Production Wells (gpm)
1	0	250	2,000	2,250
2	0	250	2,000	2,250
3	0	250	2,000	2,250
4	0	250	2,000	2,250
5	0	250	2,000	2,250
6	0	0	2,000	2,000
7	0	0	2,000	2,000
8	0	0	2,000	2,000
9	0	0	2,000	2,000
10	0	0	2,000	2,000
11	0	0	2,000	2,000

Source: Baker Consultants, Inc. 2000a.

Table 3.2-24
Predicted Recovery (or Increase) of Ground Water Levels
at Surface Water Rights Locations
(No Action Alternative)

Map#	Application Number ¹	Permit Status	Use	Model Year 25	Model Year 50	Model Years 150	Model Year 400
				(feet) ²			
S1	0723	Vested	Irrigation	None	+10	> +50	+70 to +100
S3	01725	Vested	Irrigation	None	None	+30 to +50	+30 to +50
S6	04228	Vested	Stock	None	+10	+50	+70 to 100
S11	22759	Certificated	Milling & Domestic	None	+10	+50	+70
S12	24497	Certificated	Irrigation and Domestic	None	None	+10 to +30	~+30
S13	28960	Certificated	Irrigation and Domestic	None	None	+10 to +30	~+30

¹Includes both water rights and applications for water rights on file with the State Engineer's Office.

²Plus (+) indicates a predicted increase in water levels compared to existing conditions

Numerical model simulations of mine-induced drawdowns and recovery associated with the No Action alternative at years 25, 50, 75, 100, 150, 200, and 400 during the postmining period were evaluated to determine the maximum depth, areal extent, timing and duration of drawdown and recovery (Baker Consultants, Inc. 2000a). The results for model years 25, 50, 150 and 400 are presented in **Figures 3.2-22 to 3.2-25**, respectively, to represent the simulated changes in ground water conditions in the postmining period. Note that for comparative purposes, the selected model years (25, 50, 150, 400) are the same as those illustrated and discussed previously for the Proposed Action (**Figures 3.2-13 to 3.2-16**).

As shown in **Figure 3.2-22**, in model year 25 ground water levels in the southern portion of the Copper Canyon area are expected to be lower than baseline conditions. The area of drawdown, as defined by the 10-foot drawdown contour, is predicted to extend approximately 2.5 miles in a north-south direction and 2.5 miles in an east-west direction centered on the Midas Pit area. Maximum drawdown of up to 500 feet is predicted to occur in the Midas Pit area caused by interflow of ground water from existing bedrock boreholes in this area to the alluvial aquifer (Baker Consultants, Inc. 2000a). Between model years 25 and 400, the areal extent of the drawdown is predicted to remain relatively constant over the southern Copper Canyon Area.

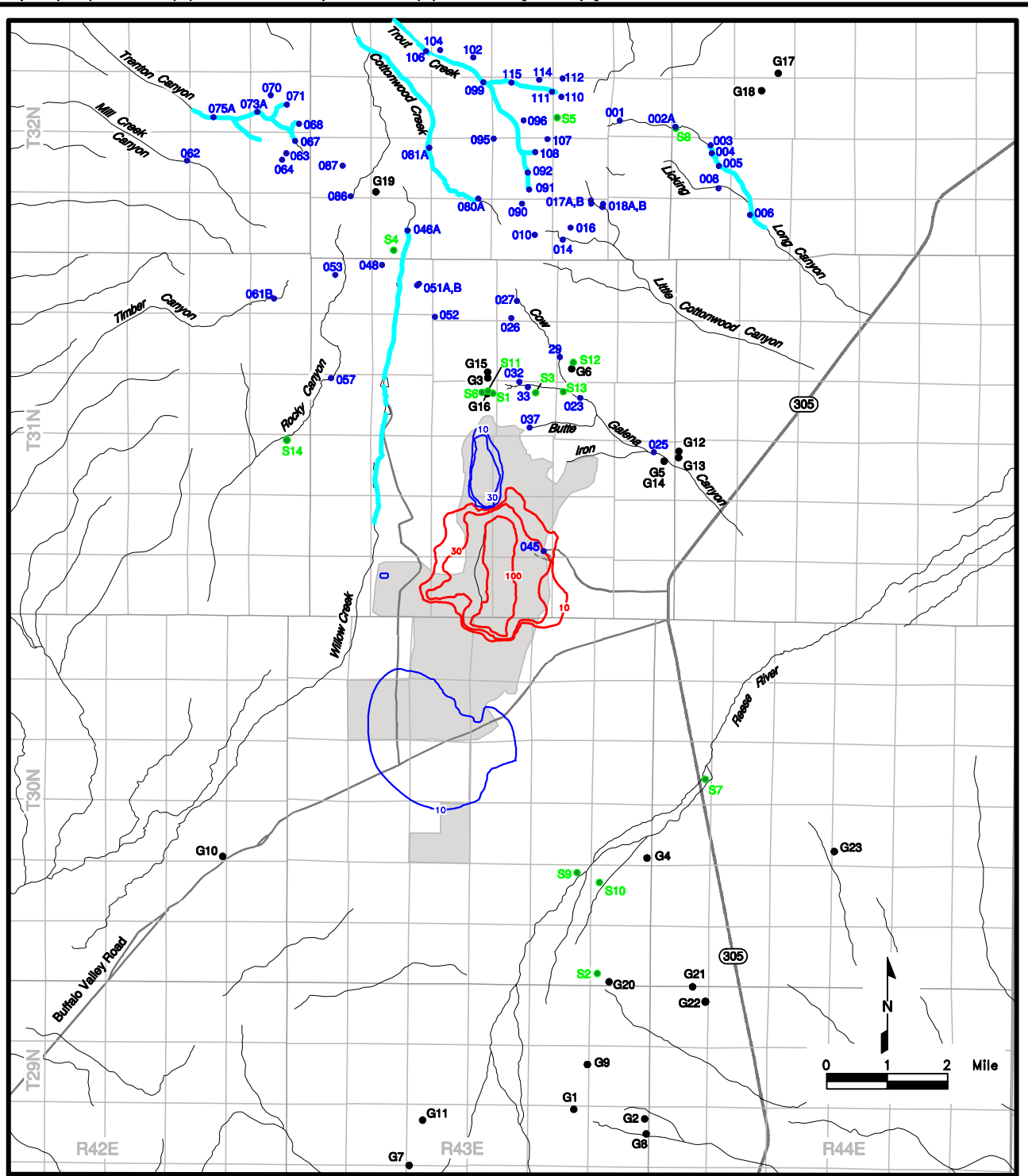

Explanation

- Road
- Drainage
- Perennial Stream
- Drawdown (Feet)
- Recovery (Feet)
- Project Facility Boundary
- G# Ground Water Right on File at State Engineer's Office
- S# Surface Water Right on File at State Engineer's Office
- 037# Perennial Spring

Phoenix Project

Figure 3.2-22

**Predicted Change in
Ground Water Levels at
Model Year 25
(No Action Alternative)**

Source for Base: Brown and Caldwell 1998b, JBR 1996d,g
Source for Drawdown: Baker Consultants Inc. 2000a

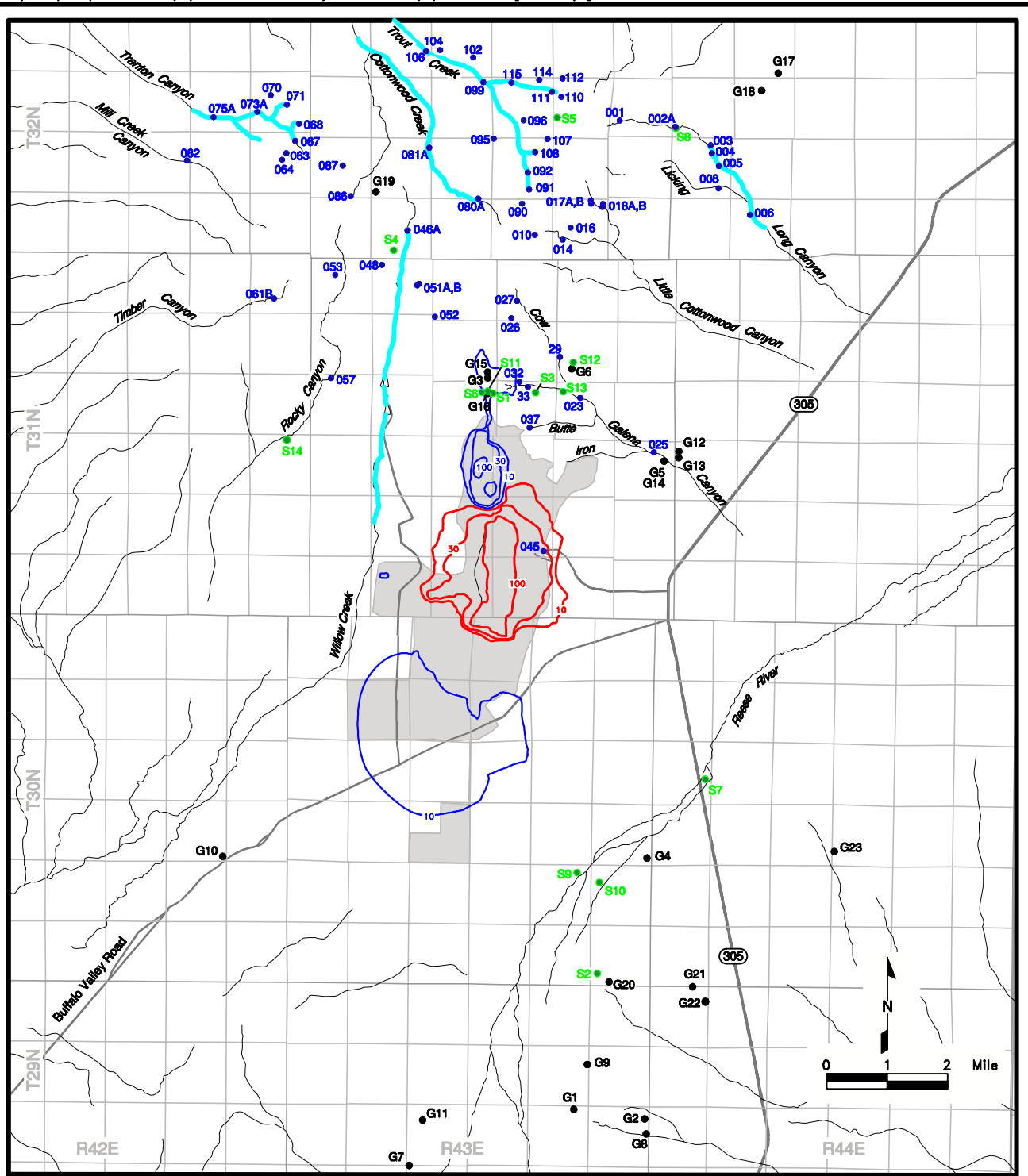

Explanation

- Road
- Drainage
- Perennial Stream
- Drawdown (Feet)
- Recovery (Feet)
- Project Facility Boundary

- G8● Ground Water Right on File at State Engineer's Office
- S9● Surface Water Right on File at State Engineer's Office
- 037● Perennial Spring

Phoenix Project



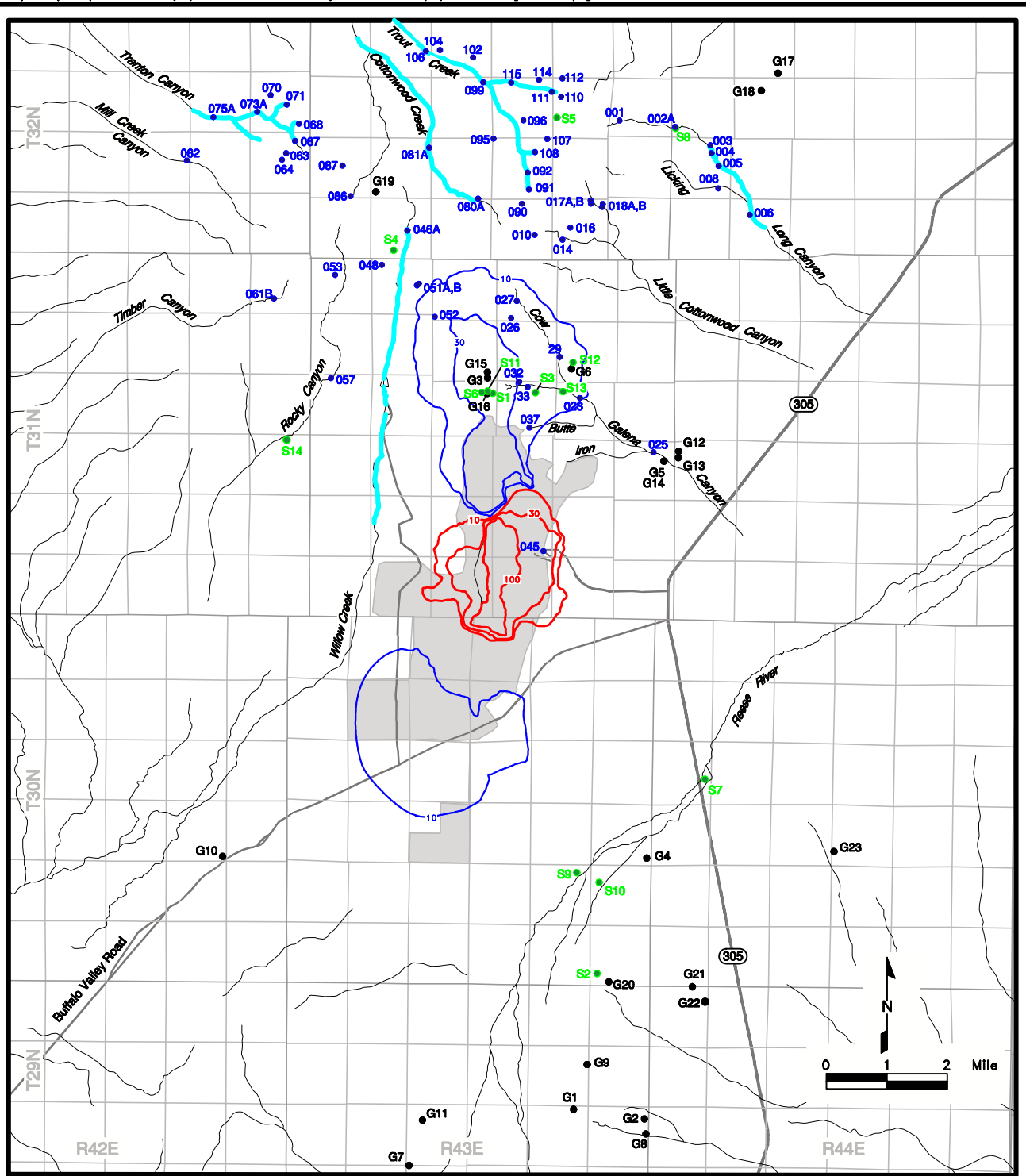

Figure 3.2-23

**Predicted Change in
Ground Water Levels at
Model Year 50
(No Action Alternative)**

Source for Base: Brown and Caldwell 1998b, JBR 1996d,g
Source for Drawdown: Baker Consultants Inc. 2000a



Explanation

- | | | | |
|---|---------------------------|---|---|
|  | Road |  | G# • Ground Water Right on File at State Engineer's Office |
|  | Drainage |  | S# • Surface Water Right on File at State Engineer's Office |
|  | Perennial Stream |  | 037 • Perennial Spring |
|  | Drawdown (Feet) | | |
|  | Recovery (Feet) | | |
|  | Project Facility Boundary | | |

Phoenix Project

Figure 3.2-24

**Predicted Change in
Ground Water Levels at
Model Year 150
(No Action Alternative)**

Source for Base: Brown and Caldwell 1998b, JBR 1996d,g
Source for Drawdown: Baker Consultants Inc. 2000a

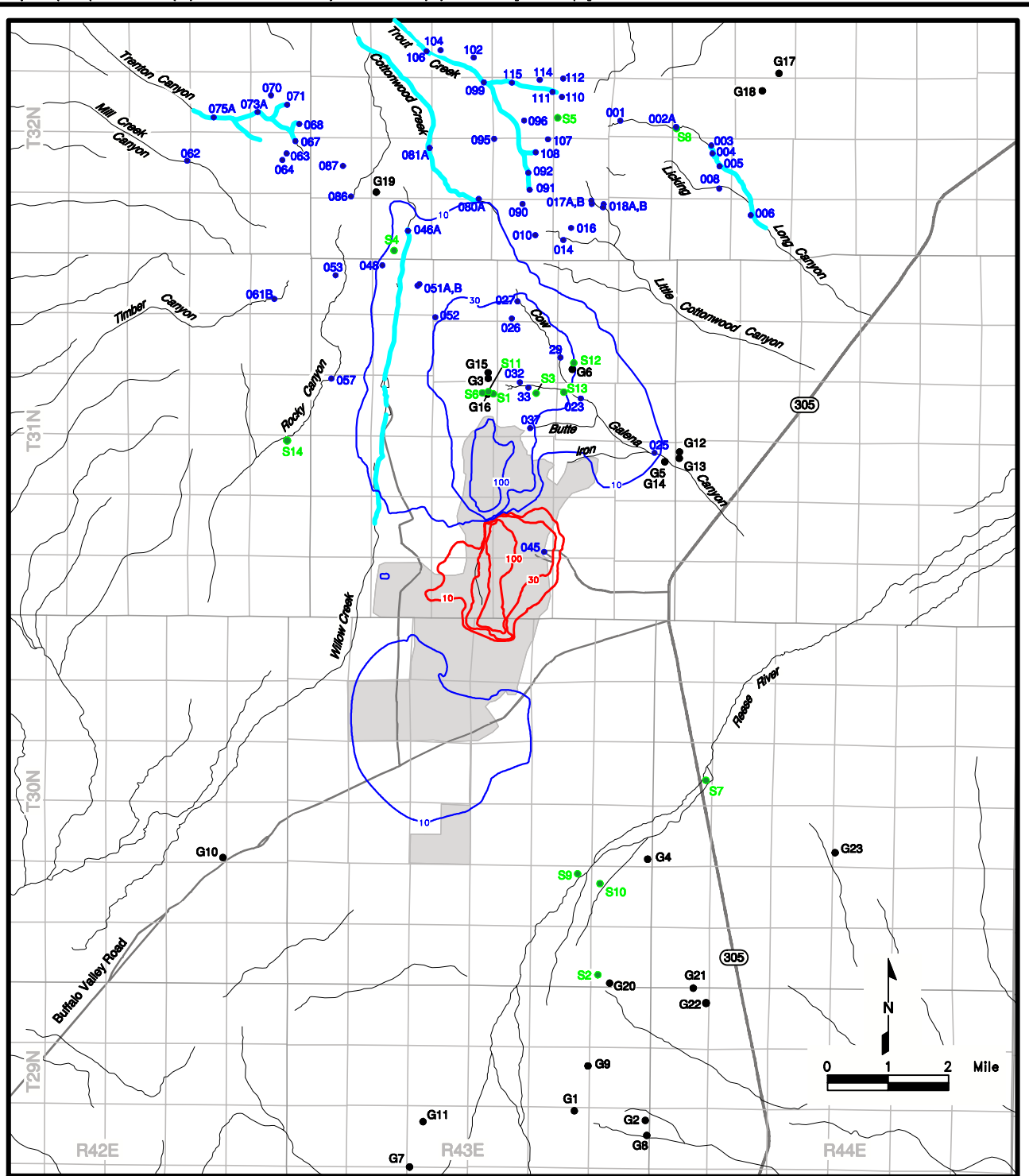

Explanation

- Road
- Drainage
- Perennial Stream
- Drawdown (Feet)
- Recovery (Feet)
- Project Facility Boundary

- G8● Ground Water Right on File at State Engineer's Office
- S9● Surface Water Right on File at State Engineer's Office
- 037● Perennial Spring

Phoenix Project

Figure 3.2-25

Predicted Change in Ground Water Levels at Model Year 400 (No Action Alternative)

Source for Base: Brown and Caldwell 1998b, JBR 1996d,g
 Source for Drawdown: Baker Consultants Inc. 2000a

3.0 AFFECTED ENVIRONMENT AND ENVIRONMENTAL CONSEQUENCES

Two distinct areas of ground water recovery are predicted to occur in the postmining period under the No Action alternative: one centered in the vicinity of the chloride plume mitigation well field area, and another centered on the Fortitude Pit area. In the chloride plume well field area, ground water elevations would recover (or rise) approximately 10 feet. Most of this recovery occurs by model year 25 with some expansion of the recovery area occurring out to model year 50. After model year 50, there is little change in the predicted recovery area suggesting that this area reaches full recovery to premine conditions between model years 25 and 50.

Ground water recovery is predicted to occur around the Fortitude Pit area and over a broad area located to the north of the Fortitude Pit. Ground water levels are expected to gradually rise more than 200 feet locally around the Fortitude Pit as the pit lake develops. By model year 400 (**Figure 3.2-25**), ground water recovery, as defined by areas that would experience a 10-foot or greater increase in ground water levels, would extend throughout the upper Willow Creek and Galena Canyon areas.

Pit Lake Development. Under the No Action alternative, pit dewatering would cease in the Fortitude Pit, and the ground water elevation would rebound and cause the formation of a pit lake. The Fortitude Pit lake is predicted to begin to form immediately and to continue to fill as the water table continues to rise over the next several hundred years. At 95 percent recovery (model year 400), the pit lake is expected to have a surface elevation of 6,050 feet amsl (**Figure 3.2-26**), a depth of 285 feet, and a surface area of 38 acres. In addition, at model year 400, the lake would be near equilibrium conditions with inflow approximately equal to outflow. The estimated rate of inflow that time would include 45 gpm from precipitation, 2.5 gpm from surface runoff, and 44 gpm of ground water inflow (from the north and west side of the lake). The rate of outflow at this time would include 55 gpm from evaporation, and 40 gpm of outflow (from the south side of the lake) (Baker Consultants, Inc. 2000a).

In addition to the Fortitude Pit lake, a small pit lake is predicted to form in the Minnie Pit. Ground water modeling results predict that the Minnie Pit lake would rise to a final equilibrium elevation of 5,649 amsl by approximate model year 20 (**Figure 3.2-26**), an estimated depth of 19 feet, and have a surface area of approximately 4.4 acres. The estimated rate of inflow at that time

would include 5 gpm from precipitation, and 0.5 gpm from surface runoff; the rate of outflow would include 5 gpm from evaporation. Under near equilibrium conditions, the Minnie Pit lake is expected to have limited interaction with the surrounding ground water system (Baker Consultants, Inc. 2000a). Water that was observed in the bottom of the Minnie Pit in late 1999 disappeared in early 2000, probably due to drainage by exploration boreholes drilled in this area. Based on these recent observations, it seems unlikely that ground water would accumulate in the Minnie Pit in the future.

Impacts to Perennial Streams and Springs. As discussed above, numerical modeling indicates that a cone of drawdown would form in lower Copper Canyon, and water levels would rise over a broad area extending from upper Copper Canyon north to the headwaters of Willow Creek. There are no perennial stream reaches located within or near the predicted drawdown area. Therefore, impacts to perennial streams from drawdown are not anticipated. The predicted long-term rise in ground water levels could result in an increase ground water discharge (in the form of spring discharge to the stream) in the upper perennial reach of Willow Creek. The potential for increased surface flow is considered a beneficial impact on the stream.

Only one perennial spring (Spring 45) is located within the predicted drawdown area (**Figures 3.2-22 to 3.2-25**). This spring is located within an area that is predicted to experience a long-term reduction in ground water levels ranging from approximately 30 feet at model year 25, to 50 to 70 feet at model year 150. Flow within this spring may be reduced or eliminated. Any impact that occurs to this spring is unlikely to recover in the foreseeable future.

Impacts to Surface Water Rights. None of the surface water rights located in the project vicinity occur within the drawdown area predicted for the No Action alternative. Therefore, localized mine-induced drawdown associated with the No Action alternative is not likely to impact any water resources associated with existing surface water rights. Under the No Action alternative (**Table 3.2-24**), ground water levels are predicted to rise relative to existing conditions in the vicinity of these surface water rights (**Figures 3.2-22 to 3.2-25**). For surface water rights that are dependent, at least in part on ground water discharge, a potential increase in ground water

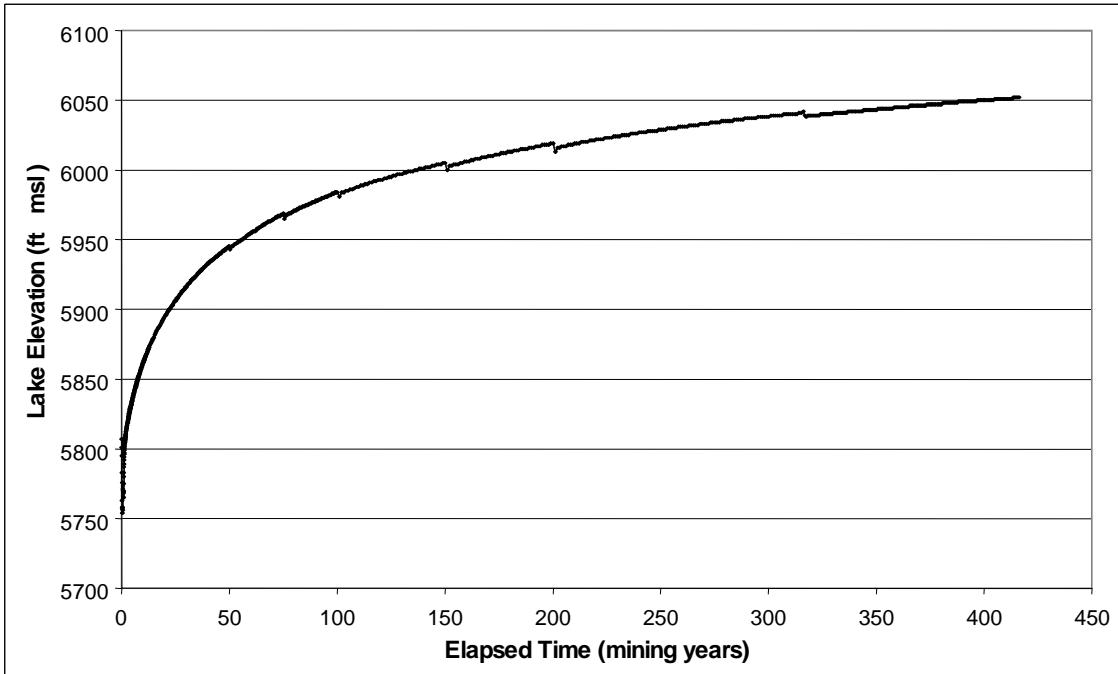

Fortitude Pit

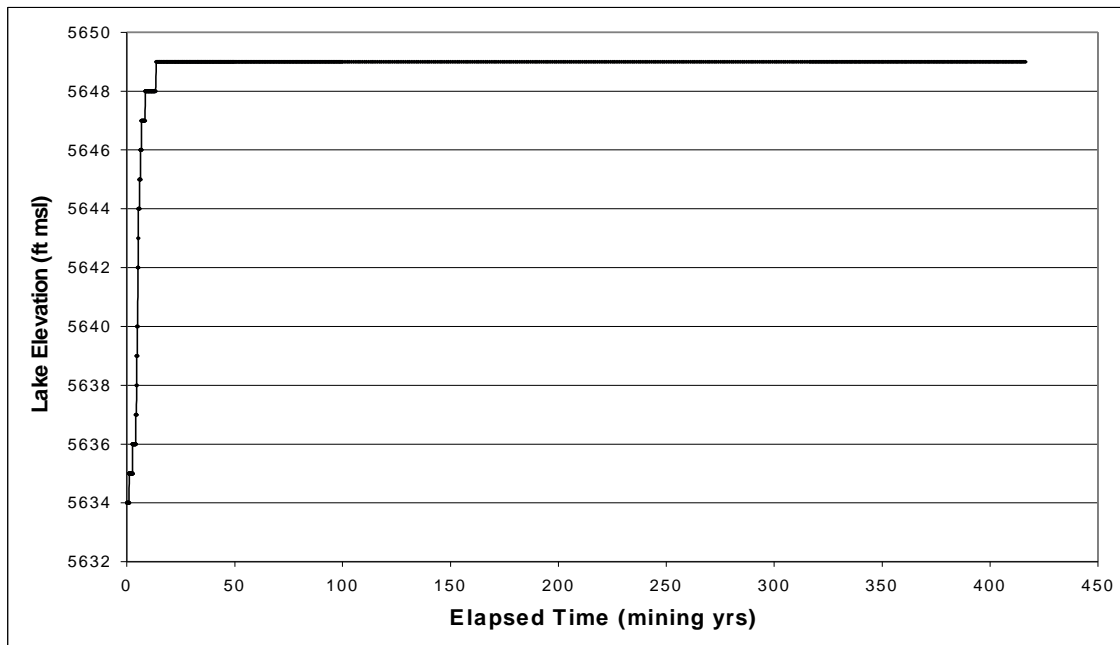

Minnie Pit

Phoenix Project

Figure 3.2-26

Rate of Pit Lake
Development
(No Action Alternative)

Source: Baker Consultants Inc. 2000a

3.0 AFFECTED ENVIRONMENT AND ENVIRONMENTAL CONSEQUENCES

levels could increase the flow available at the point of diversion for the surface water rights.

Impacts to Ground Water Rights. An inventory of ground water rights is summarized in Section 3.2.1.3. Potential impacts to ground water rights were evaluated by determining the potential drawdown and recovery of ground water levels over time at the points of diversion associated with inventoried ground water rights. None of the inventoried ground water rights located in the project vicinity occur within the drawdown area predicted for the No Action alternative. Therefore, localized mine-induced drawdown associated with the No Action alternative is not likely to impact any water resources associated with existing ground water rights. As shown in **Table 3.2-25**, under the No Action alternative ground water levels are predicted to rise relative to existing conditions in the vicinity of existing ground water rights (**Figures 3.2-22 to 3.2-25**). The predicted maximum rebound (or rise) in ground water levels varies between the different ground water right locations but ranges from approximately 10 feet to over 100 feet. Actual impacts would depend on the site-specific conditions, well completion details, and timing of the water level rebound. Relatively small changes in ground water levels (such as 10 or 20 feet) are unlikely to have any effect on water supply wells at these locations. However, larger increases such as those in the tens of feet to hundreds of feet range could potentially increase yield and reduce pumping cost.

Water Quality Impacts

Current mining operations as authorized by the BLM and the State of Nevada would continue under the No Action alternative. Upon completion of mining the existing facilities would be closed and reclaimed in accordance with current permits and state and federal requirements. Features that would remain at the site and that have been evaluated for water quality impacts include pit lakes and the existing permitted waste rock, heap leach, and tailings facilities.

Pit Lake Water Quality. A hydrochemical evaluation of pit lake water quality under the No Action alternative was conducted by Exponent (2000a). The existing features that were evaluated included the lake in the Fortitude Pit and shallow (less than 10 feet deep) water bodies intermittently present in the P-1 and P-2 depressions of the Bonanza Pit.

Fortitude Pit Lake. A lake formed in the Fortitude Pit after pit dewatering stopped in January 1993. Water samples were collected in summer 1995 through spring 1996, in December 1997 (Exponent 2000a), and in January 1999 (Exponent 2000a). The results of the water quality analyses were the primary basis for predictions of future water quality, supplemented by nearby ground water quality, pit wall-rock chemistry, runoff and seep water quality, and predicted future hydraulic conditions.

The water sampled from the Fortitude Pit lake had neutral pH and met all Nevada primary drinking water quality criteria. The water exceeded secondary standards for iron, aluminum, manganese, and sulfate. Water quality results for the January 1999 sample are shown in **Table 3.2-26**. Seep and runoff water entering the pit lake were sampled and found to have low pH (3.0 to 3.2) and metals concentrations in excess of water quality standards, but this water was neutralized upon entering the pit lake. The likely cause of the observed neutralization is the outcrop of Antler Peak limestone present in the pit bottom.

Metals and other constituents have been observed to form solid precipitates as the water is neutralized. These precipitates settle to the bottom of the lake, but could potentially be redissolved or made available to aquatic organisms under seasonal lake turnover (mixing) conditions.

Over a longer period, the concentrations of constituents in the Fortitude Pit lake could increase due to evaporative concentration. The solubility of gypsum ($\text{CaSO}_4 \cdot 2\text{H}_2\text{O}$) would likely provide an upper limit on the concentration of sulfate at approximately 1,000 mg/L. Ground water flow modeling (Baker Consultants, Inc. 2000a) predicts that an outflow of pit lake water to downgradient ground water would occur at a rate of approximately 40 gallons per minute after steady-state conditions are reached. This water is predicted to have neutral pH and a sulfate concentration of approximately 1,000 mg/L with some constituents exceeding secondary drinking water quality standards (Exponent 2000a).

P-1, P-2, and Minnie Pit Lakes. Shallow pit lakes formed in the P-1 and P-2 depressions of the Bonanza Pit in August 1997 (Exponent 2000a). Water from these pits was sampled in 1998 (**Table 3.2-26**) and found to be below the Nevada criterion for pH and to exceed water quality standards for several metals. The ponded water disappeared from the P-1 Pit in late 1998,

**Table 3.2-25
Predicted Recovery (or Increase) of Ground Water Levels at Ground Water Rights Locations
(No Action Alternative)**

Map#	Application Number ¹	Permit Status	Use	Model Year 25	Model Year 50	Model Years 150	Model Year 400
				(feet) ²			
G3	22990	Certificated	Milling	None	+10 to +30	+50 to +70	+70 to +100
G6	24496	Certificated	Domestic	None	None	+10 to +30	~+30
G10	44755	Certificated	Stock	None	None	None	None
G15	49141	Ready for Action (Protested)	Mining, Milling & Domestic	None	+10 to +30	+50 to +70	+70 to +100
G16	49142	Ready for Action (Protested)	Mining, Milling & Domestic	None	+10 to +30	+50 to +70	+70 to +100

¹Includes both water rights and applications for water rights on file with State Engineer's Office.

²Plus (+) indicates increase in ground water levels relative to existing conditions.

**Table 3.2-26
Selected Pit Lake Water Quality**

Location Analyte (mg/L unless specified)	Nevada Drinking Water Standards ¹		Fortitude Pit	P-1	P-2
	Primary	Secondary	1/5/99	10/6/98	3/30/98
pH (std. units)		6.5 - 8.5	7.29	3.66	5.1
Total dissolved solids		500, 1,000	850	2260	1090
Aluminum		0.05 - 0.2	0.231	7.06	<0.1
Antimony	0.006		<0.002	0.005	0.006
Arsenic	0.05		0.036	0.003	<0.025
Barium	2.0		0.022	0.024	<0.1
Beryllium	0.004		<0.002	0.004	<0.002
Boron			0.105	0.303	0.18
Cadmium	0.005		<0.002	0.083	0.0037
Calcium			140	314	113
Chloride		250, 400	17.9	121	88.3
Chromium	0.1		<0.008	<0.008	<0.025
Copper	1.3	1.0	0.014	12.1	<0.1
Fluoride	4.0	2.0	0.3	2.7	0.9
Iron		0.3, 0.6	9.25	2.43	11.9
Lead	0.015		<0.001	<0.001	<0.005
Magnesium		125, 150	50.8	141	66.9
Manganese		0.05, 0.1	1.83	10	1.22
Mercury	0.002		<0.0002	<0.0002	<0.0005
Nickel	0.1		<0.016	1.05	0.1
Nitrite+Nitrate as N	10		<0.02	<0.02	NR
Selenium	0.05		<0.002	0.014	<0.005
Silver		0.1	<0.005	<0.005	<0.025
Sulfate		250, 500	431	1450	591
Thallium	0.002		<0.001	0.001	<0.001
Zinc		5.0	0.173	6.59	<0.1

Source: Exponent 2000a.

¹ See **Table 3.2-3** for more information on drinking water standards.

NS = No drinking water standards exist for this analyte.

3.0 AFFECTED ENVIRONMENT AND ENVIRONMENTAL CONSEQUENCES

corresponding with a period of exploration drilling in the area. The exploration borehole plugs may not have functioned as designed after abandonment and may have provided conduits to drain a shallow saturated zone feeding the pond. The most recent ground water modeling (Baker Consultants, Inc. 2000a) indicates that the Bonanza Pit depressions are expected to remain dry in the future.

Water was observed at the base of the Minnie Pit in late 1999, but disappeared in early 2000 before it could be sampled. This disappearance also corresponded with a period of exploration drilling. While the most recent ground water modeling predicts that the Minnie Pit would fill with water to a depth of 19 feet, the recent spontaneous drainage of this pit indicates that it also would be likely to remain dry in the future. If water does pond in the Minnie Pit, it would likely be acidic with some elevated metals concentrations, as the bedrock in this pit is not oxidized and no limestone outcrops are present to neutralize acidic water.

Waste Rock Facilities. There are 16 existing surface-deposited waste rock facilities at the project site (see Section 2.2.1 and *Figure 2-2*). These facilities would be closed and reclaimed with no change in area under the No Action alternative.

Design. The existing waste rock facilities were all constructed on native ground in lifts of 50 to 300 feet using end-dump techniques. Closure activities are ongoing for many of the existing facilities, and final closure and reclamation requirements are subject to change based on ongoing characterization activities. For the purpose of characterizing the impacts from the existing waste rock facilities under the No Action alternative, it was assumed that the existing facilities would remain in their current configurations with minimal recontouring and would be covered with a 2-foot thick vegetated cap of oxide rock or other suitable growth medium.

Site Conditions. The depth to ground water beneath the existing waste rock facilities ranges from approximately 50 feet beneath portions of the South Fortitude Waste Rock Facility to approximately 400 feet beneath the Copper Leach Facility in Philadelphia Canyon (Exponent 2000a, Appendix B4). The general geologic conditions beneath the waste rock facilities are described in Section 3.1.1.3. Waste rock facilities constructed in upland portions of the project area are generally underlain by bedrock, while facilities constructed in

down-valley locations are generally underlain by alluvium.

The Copper Leach Facility was leached with sulfuric acid during past operations, and surface seepage containing elevated sulfate and metals is collected and treated as part of ongoing closure activities.

Geochemical Characterization and Impacts. Characterization of existing waste rock and copper leach facilities was conducted by Exponent (2000a). The geochemical testing program and results are described in Section 3.2.1.4. Acid-base accounting tests were conducted on 213 samples of existing waste rock, with paste pH and moisture content also determined for selected samples. The facilities were all found to be net acid-generating, with the exception of the Natomas Waste Rock Facility, which is composed primarily of neutral material. Paste pH values were found to be highest in the upper 10 feet of the Natomas Waste Rock Facility, while paste pH values were consistently near 4 throughout the Copper Leach Facility. Humidity cell tests of selected samples confirmed that a net neutralization potential of zero is a reliable cutoff value between acid-generating (negative net neutralization potential) and neutral (positive net neutralization potential) materials.

Exponent (2000a) modeled the short-term (up to 130 years) and long-term (beyond 130 years) effects of infiltration of acidic leachate on ground water quality beneath the existing waste rock facilities by combining information on waste rock chemistry, sulfide oxidation rates, and the flux of water both within and beneath the facilities. The predicted sulfate concentrations in ground water at the downgradient edge of each facility are presented in *Table A-5* in Appendix A. Effects on ground water quality beneath the waste rock facilities are predicted to occur within 30 years at numerous facilities under the No Action alternative. Sulfate concentrations would be highest beneath facilities located in smaller hydrologic basins, which have smaller recharge areas for ground water that flows beneath the facility, and thus less dilution of waste rock seepage. Maximum sulfate concentrations are expected to occur between 100 and 1,000 years, with concentrations subsequently decreasing. It is important to reiterate that there is considerable uncertainty associated with long-term predictions of potential impacts to ground water quality resulting from infiltration through the waste rock facilities. Some of the key sources of uncertainty are the same as those outlined previously in the Section 3.2.2.1, in the discussion of Waste Rock

Facilities. Due to these uncertainties, long-term predictions of increased sulfate concentrations in ground water should be viewed as indicators of long-term trends rather than absolute values. The predictions suggest that without mitigation, there is a potential for leachate generated within the waste rock facilities to eventually impact ground water quality; however, the actual timing and magnitude of these impacts is uncertain.

The prediction of impacts to ground water beneath the waste rock facilities focuses primarily on sulfate because it is considered a reliable, direct indicator of the effects from oxidation of waste rock. Sulfate also is among the most conservative (i.e., most mobile in ground water) constituents released from oxidation of waste rock and therefore would provide the earliest indication of effects on ground water quality. Other constituents also would be present with sulfate in the waste rock seepage, and qualitative predictions of constituents expected to be present in ground water beneath the waste rock facilities at concentrations above their drinking water standards were provided by Exponent (2000a, Appendix D2) and are summarized in **Table 3.2-20**. These predictions are based on the relative concentrations of sulfate and other constituents in waste rock leachate. In general, when sulfate concentrations exceed several hundred milligrams per liter, other constituents are predicted to be present at concentrations above their respective standards. It should be noted that the predictions of other constituents are conservative and do not account for any potential neutralization or attenuation along ground water flow paths.

Transient impacts to runoff water quality may occur from the contact of sulfidic waste rock currently present on the surface of the waste rock facilities with precipitation. MWMP tests of waste rock indicated that runoff from sulfide waste rock could be acidic and contain dissolved sulfate and metals at concentrations above water quality standards. The effects on runoff water quality would be expected to be minimal following closure and construction of 2-foot thick caps on the facilities.

Testing of the interaction of infiltrating water with alluvium (Appendices A21 and B4, Exponent 2000a) indicated that the alluvium has some capacity to neutralize acidic water, but that it also contains some evaporite minerals that could dissolve and release additional constituents to infiltrating water. While the alluvium could

attenuate some metals, other trace constituents were also released from the alluvium to the infiltrating water in the tests. Attenuation of constituents during migration through alluvium beneath the waste rock facilities was not included in the predictions of ground water concentrations.

The currently approved plans for the existing facilities require characterization and mitigation at any facilities expected to affect ground water quality. However, there is no bonding requirement currently in place to fund long-term monitoring and mitigation for the No Action alternative.

Acid-base accounting tests and MWMP tests of sulfidic waste rock (Exponent 2000a) indicate that the rock has the potential to release acid, sulfate and metals to runoff water during storm events. The State of Nevada permit for existing operations requires that runoff water be collected if necessary to prevent degradation of water quality. Construction of 2-foot thick caps on existing facilities would prevent the contact of storm water with sulfidic waste rock. However, under the No Action alternative, the cap requirements for reclamation and closure of existing waste rock facilities would be determined on a case-by-case basis and depend on the site specific conditions.

The water quality impact from runoff from reclaimed waste rock facilities is expected to be minimal based on MWMP testing. Some transient impacts to runoff water quality may occur when precipitation comes in contact with sulfidic waste rock in the waste rock facilities in their current open configuration. Under the current plans, surface water quality monitoring would continue through the operational period, and for some unspecified time in the postclosure period. If the monitoring detects that any surface water runoff contains concentrations that exceed the applicable water quality standards, runoff would be captured and managed in compliance with the storm water management plan. Runoff from waste rock facilities following placement of the vegetated caps is expected to be minimal. Therefore, no offsite impacts to surface water quality from runoff are expected. Additional information on storm water management is provided below.

Closure and stabilization of existing waste rock facilities would be accomplished under the State of Nevada Water Pollution Control Act regulations, and the applicable permits and work plans issued in accordance with these regulations. Under these regulations, BMG and NDEP are systematically conducting facility characterizations and

3.0 AFFECTED ENVIRONMENT AND ENVIRONMENTAL CONSEQUENCES

implementing closure actions to minimize the potential for degradation of waters of the State. Closure actions would likely include placing non-acid-generating caps over waste rock materials that have a potential to generate acid. Exponent's (2000a) analysis indicates that even with a cap, these waste rock piles would likely generate acid leachate that would eventually infiltrate to ground water. The NDEP can require verification monitoring for up to 30 years after mining to evaluate the need for additional mitigation measures. However, the modeling results suggest that percolation through many of these facilities would take greater than 30 years to reach the ground water table. Therefore, impacts to ground water would likely appear after the 30-year verification monitoring period. There is currently no plan (or bonding) in place to mitigate the predicted long-term infiltration from the waste rock facilities. In addition, there is no proposal or requirement for long-term monitoring of ground water quality either at or downgradient of the facilities. Therefore, under the No Action alternative, there is the potential for long-term impacts to ground water quality during the postclosure period. These impacts to water quality are anticipated to eventually exceed one or more Nevada or federal primary or Nevada secondary enforceable maximum contaminant levels for drinking water. Therefore, this potential for ground water degradation downgradient from the waste rock facilities is considered a significant impact.

Heap Leach Facilities.

Design and Operation. The existing Reona Heap Leach Facility consists of a lined heap leach pad and associated beneficiation facilities. Leach operations are ongoing under the current Reona Project and could continue under the No Action alternative. The leach pad is lined to allow collection of leach solutions and to prevent their infiltration to ground water.

Closure and Reclamation. The heap leach pad and associated event pond would be closed and reclaimed in accordance with the BLM's cyanide management plan and Nevada water quality regulations. All residual leach solution would be allowed to drain from the pile, and the pile would then be rinsed with water until residual concentrations of cyanide and other constituents meet relevant Nevada standards. The pile would then be recontoured to allow for placement of growth medium and reseeded. Any residual solutions in the event pond would be evaporated, and the sediments would be tested for hazardous

characteristics. Any hazardous sediments would be disposed of according to applicable regulations. The pond liner material would be removed and buried in the pond area, which would be backfilled or reshaped to prevent collection of water. Monitoring of ground water quality would be conducted during and after closure as required under the existing plan of operations.

Impacts. Operation of the heap leach facility is not anticipated to have significant impacts to water quality, since the facility is designed to operate as a lined facility with little seepage and runoff. Proper closure of the facility under the No Action alternative would further minimize the potential for impacts to water quality during the postclosure period.

Tailings Facilities.

Design and Site Conditions. The inactive gold and copper tailings facilities are underlain by native ground. Alluvium beneath the tailings is estimated to be at least 400 feet thick.

A chloride plume currently exists in the alluvial ground water beneath the tailings impoundment. This plume has been addressed under the current Water Pollution Control Permit. In accordance with permit conditions, ground water from the plume is currently recovered by extraction wells and used for dust suppression on the mine site.

Closure and Reclamation. The tailings facility would be recontoured to a 1 percent grade and the surface compacted to provide a hydraulic barrier. Above the compacted surface, an 18- to 24-inch drain layer would be placed to reduce infiltration and prevent erosion. The drain layer would be covered with growth medium and revegetated. The natural Copper Canyon drainage would be diverted around the reclaimed tailings facility.

Impacts. The current chloride plume at the existing tailings facility is considered an existing condition and is not an impact of the No Action alternative. The plume would be mitigated as required under the current Water Pollution Control Permit. No additional water quality impacts would be expected from the inactive tailings facility under the No Action alternative.

Ore Stockpiles. Three existing ore stockpiles (Fortitude, Tomboy, and Northeast Extension) are present at the site. Ore from these stockpiles could be processed under the currently permitted Reona Project as part of the No Action alternative.

Any ore stockpiles remaining at the end of the Reona Project would be closed in the same manner as described above for waste rock facilities. Rain or snowmelt that comes in contact with these materials prior to closure could mobilize oxidation products from these sulfidic materials. The best indication of the chemistry of meteoric water after contact with ore stockpile material may therefore be the kinetic humidity cell tests described in Section 3.2.1.4. The ore stockpile materials generally have negative net neutralization potential and could contribute acid, sulfate, and metals to runoff water or to water infiltrating to underlying materials during the mining period prior to closure.

Storm Water Management

Design. Existing mining operations in Copper Canyon (including the Reona Project components and non-Reona Project components as described in Chapter 2) comprise disturbance similar to the proposed Phoenix Project. In addition, these existing operations are administered under agency permitting requirements and compliance responsibilities similar to the Proposed Action. With regard to surface water resources, these permits and commitments include:

- Reclamation permits and plans of operations for the Reona Project and the overall Battle Mountain Complex (BMG 1993; BMG and WESTEC 1993)
- Water Pollution Control Permit NEV87061 and amendments, administered by the Nevada Division of Environmental Protection for the Fortitude/Reona components
- Water Pollution Control Permit NEV90019 for the Surprise Heap Leach facilities
- ***Storm water control practices in compliance with State of Nevada General Discharge Permit No. GNV 0022225.***

Under the regulatory requirements and agency guidance at the time these documents were approved, the control of storm flow runoff, process fluids, erosion, and sedimentation were required. Meteorological and hydrologic inputs as well as engineering design reports were used to determine drainage management for storm water and containment technologies for process components under the Water Pollution Control Permit. Reclamation permits and plans of operation (and associated sureties) require

recontouring and drainageway re-establishment, revegetation, and other controls on erosion and sedimentation. These permits and associated monitoring and control programs are in effect for the existing operations and would remain in effect with appropriate updates throughout the No Action operations and reclamation.

There are differences in the post-mining topography between the Proposed Action and the No Action alternative as described in Chapter 2. Primarily, these topographic differences involve reclamation of the open pits and tailings facilities. Open pits would essentially remain in their operational configuration (with modifications for public safety) under the No Action alternative. In addition, storm runoff generated on reclaimed tailings surfaces would evaporate within the reclaimed facility under the No Action alternative reclamation plan.

Watershed Yield and Erosion, Sedimentation, and Flooding Impacts. Using the inputs and assumptions for surface water yield that were described in Section 3.2.2.1, the following changes in yield were estimated for the No Action alternative.

Table 3.2-27 is based on topographic changes that would generally prohibit drainage areas from contributing to surface water yields during operations and after reclamation of the No Action alternative. These reductions in surface water yield are not anticipated to be significant.

The No Action alternative contains provisions for restricting the contact of precipitation and snowmelt with waste rock materials having low net neutralization potential using selective handling and isolation of potentially acid-producing materials (BMG 1993). In addition, Natomas placer wastes would be covered during the Reona Project.

Surface water quality monitoring would continue, and potential impacts to surface water quality would be controlled by collection and treatment in a manner similar to the 1998 Iron Canyon event. In addition, Water Pollution Control Permit NEV87061 includes provisions for a "Work Plan and Schedule of Compliance" dated 1997 that provides for review and evaluation of water quality issues at the Fortitude Complex in order to develop and implement a comprehensive program for the physical and geochemical stabilization and closure of all Duval and BMG facilities on the site (BMG and WESTEC 1993).

3.0 AFFECTED ENVIRONMENT AND ENVIRONMENTAL CONSEQUENCES

**Table 3.2-27
Comparison of Surface Water Yields¹ for Existing Conditions and the No Action Alternative**

No Action Project Facility	Net Contributing Area Change During Operations (acres)	Yield Change During Operations (acre-feet /year)	Net Contributing Area Change After Permitted No Action Reclamation (acres)	Yield Change After Reclamation (acre-feet /year)
Pit Highwalls and Backfills	-43.7	-3.6	-43.7	-3.6
TOTAL	-43.7	-3.6	-43.7	-3.6

¹Negative value indicates a reduction in surface water yield.

Assuming that this program is rigorously pursued and accompanied by monitoring and inspection activities during the operations, closure, and reclamation phases of the No Action alternative, no significant impacts to surface water resources are anticipated.

3.2.3 Cumulative Impacts

The water resources and geochemistry cumulative effects area comprises the Lower Reese River Valley hydrographic area to the northeast; the Buffalo Valley hydrographic area to the southeast, south, and west; and the Humboldt River to the north, which includes a portion of the Clovers hydrographic area (**Figure 3.2-1**). Drawdown impacts are predicted to be localized around the mine area and are not expected to have a significant impact on the water balance within the Lower Reese River or Buffalo Valley hydrographic areas or affect the Humboldt River. Potential drawdown impacts would not interact with other ground water extraction areas associated with other mines or agricultural or municipal uses; therefore, cumulative impacts associated with drawdown are not anticipated.

Two other active mining operations are located either in or near the Battle Mountain range: the Trenton Canyon Mine located approximately 7 miles to the northwest, and the Marigold Mine located approximately 10 miles north of the Phoenix Project (Figure 2-7). Potential impacts associated with these mines are described in the recently completed EIS documents for each project (BLM 1998; BLM 2000a). According to the currently permitted plans for these mines, pit dewatering would not be required at either operation. All of the water required for the Trenton Canyon Mine is supplied by the Lone Tree Mine. The Marigold Mine operation pumps ground water at a

maximum rate of 475 gallons per minute; additional water required for the Marigold Mine is provided by delivery from the Lone Tree Mine. Neither mine is expected to affect ground water levels or reduce flows from springs or seeps within the Battle Mountain range.

Water quality impacts associated with the Proposed Action are not anticipated to occur beyond the permit boundary; therefore, no contribution to cumulative water quality impacts in the area is expected. Long-term infiltration through waste rock facilities under the No Action alternative could result in water quality impacts. These long-term impacts could result in a potential incremental increase in sulfate and metals loading to the ground water aquifers in the Lower Reese River and Buffalo Valley hydrographic areas. However, the potential flow contribution is relatively small compared to the volume of water stored in the alluvial basin aquifer systems.

The physical setting of the Battle Mountain Complex is such that the surface water and sediments yielded from source areas in the project watershed drain to Buffalo Valley, which is a closed saline/alkaline evaporative system, or to the saline/alkaline alluvial fan system along the Reese River drainage. The Reese River, with a drainage area of more than 2,000 square miles, only contributes substantial flows to the Humboldt River during infrequent periods of exceptional runoff (Eakin and Lamke 1966). In the period 1862 through 1963, the Reese River flowed over its full course into the Humboldt River only seven times, and these occurrences were during extreme floods (Nevada Department of Conservation and Natural Resources and U.S. Department of Agriculture 1964). The Reese River is typically dry in its lower reaches. Analyses based on site-specific data compared to more general regional

reconnaissance data indicate that relatively little surface water yield originates from project area drainages, and this yield would not be significantly affected over the long term. Intermittent or ephemeral flows that are produced from higher elevations are generally lost to evapotranspiration and seepage on the extensive downgradient alluvial fan systems. No additional cumulative impacts to surface water flows, watershed yields, or erosion and sedimentation are anticipated from either the Proposed Action or the No Action alternative.

3.2.4 Monitoring and Mitigation Measures

A comprehensive Water Resources Monitoring Plan (Brown and Caldwell 2000e) has been developed to establish a network of surface water and ground water monitoring stations for both water quantity and water quality at the Phoenix Project area. The plan addresses the monitoring of new project facilities that may have the potential to affect waters of the State, or pose a risk to the environment and human health. Water quantity measurements would include diversion rates from ground water pumping and surface beneficial use, water levels in monitoring wells and piezometers, and flow rates of springs, streams and other surface water monitoring locations associated with storm water controls. Water quality monitoring of surface water resources would be conducted twice a year and consist of field parameter measurement (pH, conductivity, and temperature). Water quality monitoring of ground water resources would consist of quarterly measurements of these same field parameters and collection and analysis for the NDEP Profile I list of constituents.

The proposed surface water monitoring locations are presented in **Figure 3.2-27**; proposed ground water monitoring locations are presented in **Figure 3.2-28**. Under this monitoring plan, BMG would monitor surface water quality and flow at 13 existing surface water monitoring locations, 10 existing spring locations, and 14 new surface water monitoring locations. BMG also would monitor ground water quality in 19 existing monitoring and pumping wells and 27 new monitoring wells. Monitoring associated with new facilities would be phased in over the life of the project. In addition, water levels in 49 existing monitoring wells would be monitored. Monitoring for new facilities would be initiated early enough to define downgradient baseline water quality prior to construction and operation of the proposed

facilities. Monitoring results would be provided to NDEP and BLM on a quarterly basis and summarized in an annual report. Monitoring of surface and ground water diversion rates would be submitted to the Nevada Division of Water Resources on a monthly basis and summarized in an annual report. The timeframe for continued monitoring during closure and into the postreclamation period is not specified in the Water Resources Monitoring Plan (Brown and Caldwell 2000e).

As part of the Waste Rock Management Plan (Brown and Caldwell 2000d), BMG would install unsaturated zone monitoring devices at the downgradient edge of each waste rock facility **Figure 3.2-29** to monitor performance of the waste rock facilities. These devices would be installed to collect quarterly pore water samples for analyses of NDEP Profile II constituents in the cap, the underlying waste rock material, and the substrate materials immediately beneath the facilities. Analytical results, interpretations, and recommendations associated with this unsaturated flow performance program would be submitted in an annual Waste Rock Management Report.

Installation and monitoring would be initiated immediately after final facility construction and reclamation. The time frame for continued monitoring of the waste rock facilities in the postreclamation period is not specified in the Waste Rock Management Plan (Brown and Caldwell 2000d) or Contingent Long-Term Groundwater Management Plan (Brown and Caldwell 2000c).

As proposed in mitigation measures S-1 and S-2, in Section 3.3.2 (Soils and Reclamation), the perimeter fence would be maintained, and a grazing management plan would be implemented during reclamation and in the postreclamation period. These measures are intended in part to minimize potential damage to the reclaimed caps covering the waste rock disposal facilities.

A contingent long-term ground water management plan (Brown and Caldwell 2000c) also has been developed by BMG for implementation if impacts to ground water quality beneath the waste rock facilities are anticipated. This plan specifies installation of a series of ground water recovery wells downgradient of the project facilities within the project boundary. In the event that unsaturated zone monitoring indicates that seepage from the base of a waste rock facility is occurring, ground water would be pumped from the recovery wells and the recovered water treated and reinjected.

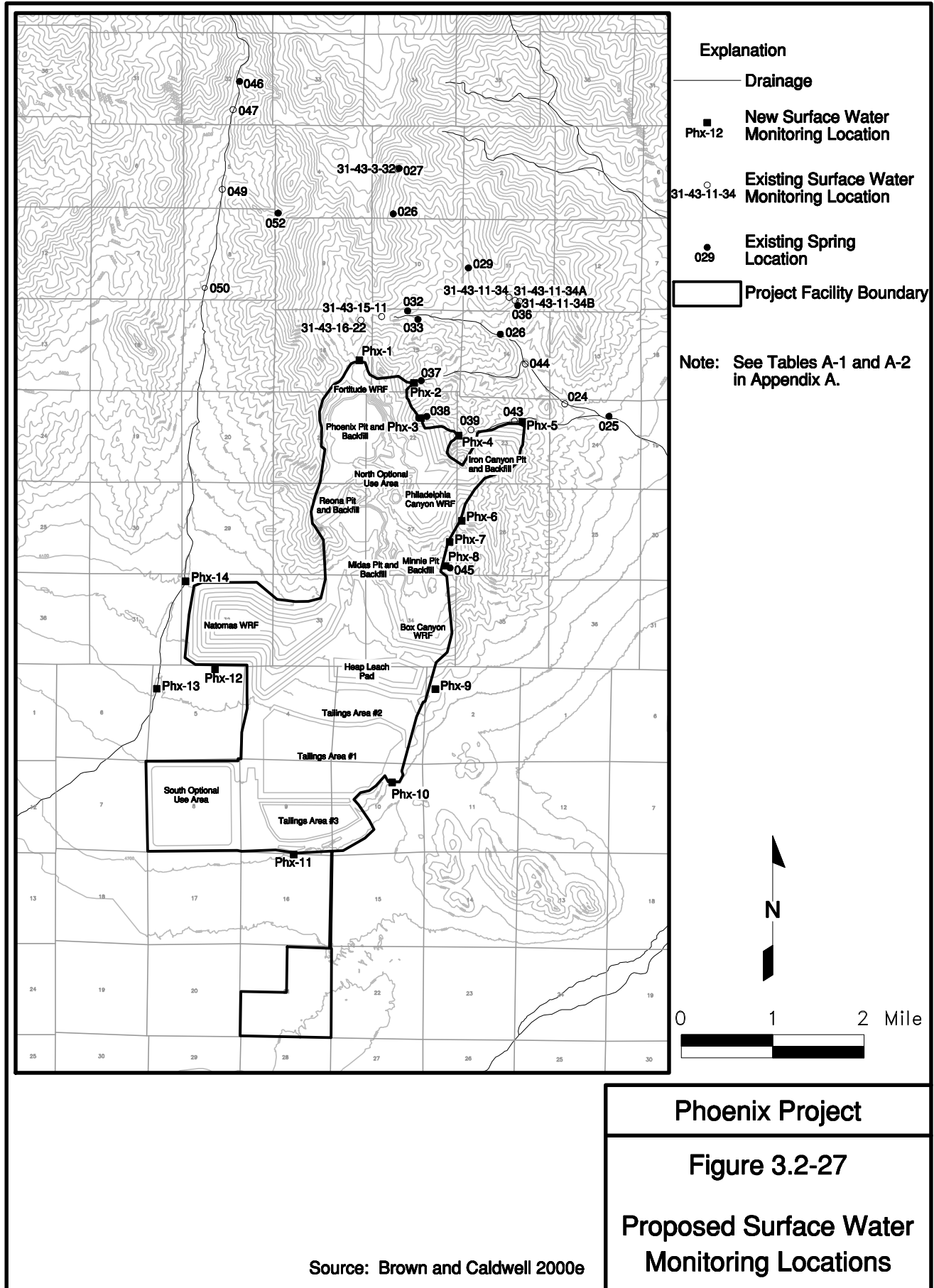

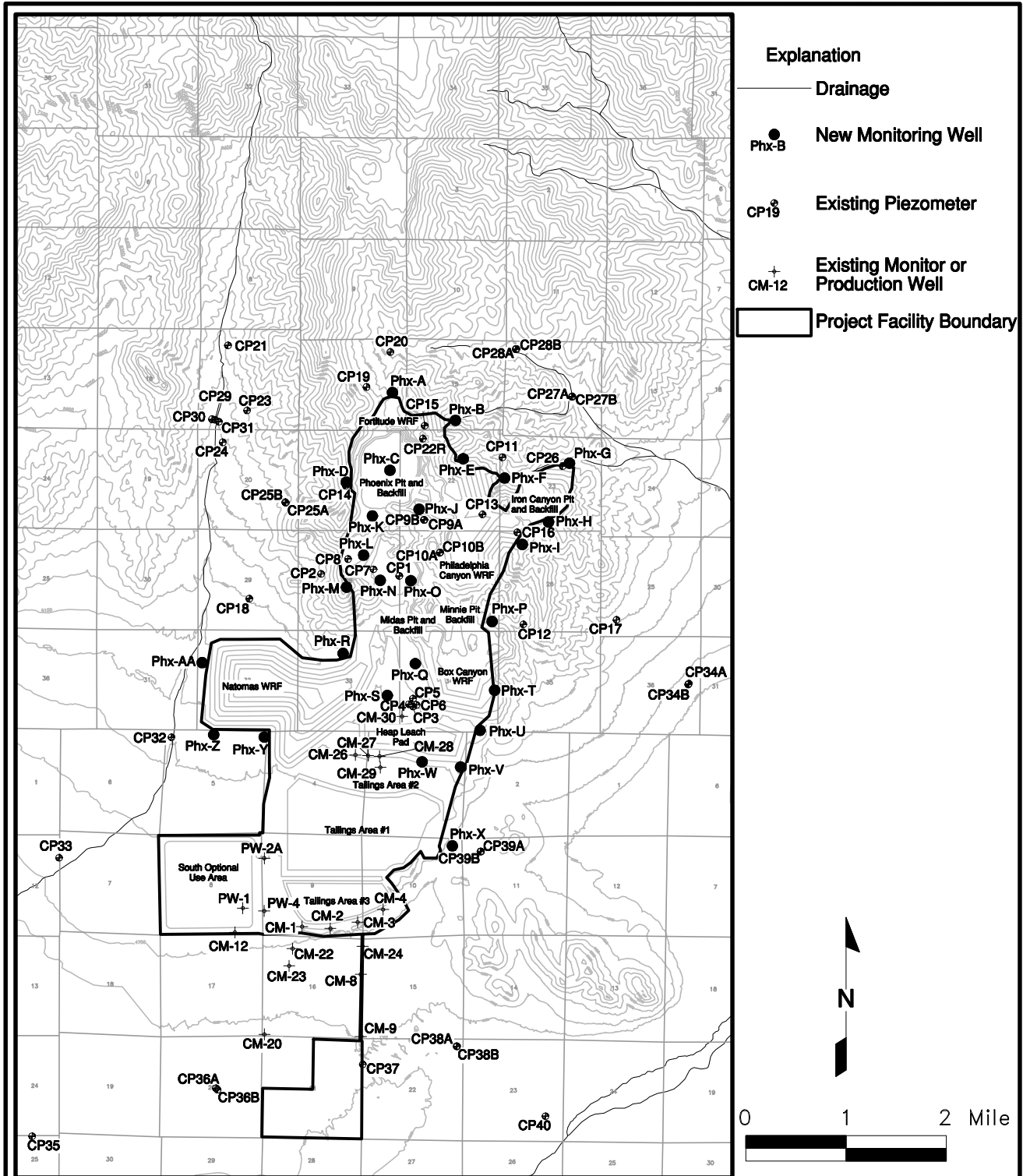

Phoenix Project

Figure 3.2-28

Proposed Ground Water Monitoring Locations

Source: Brown and Caldwell 2000e

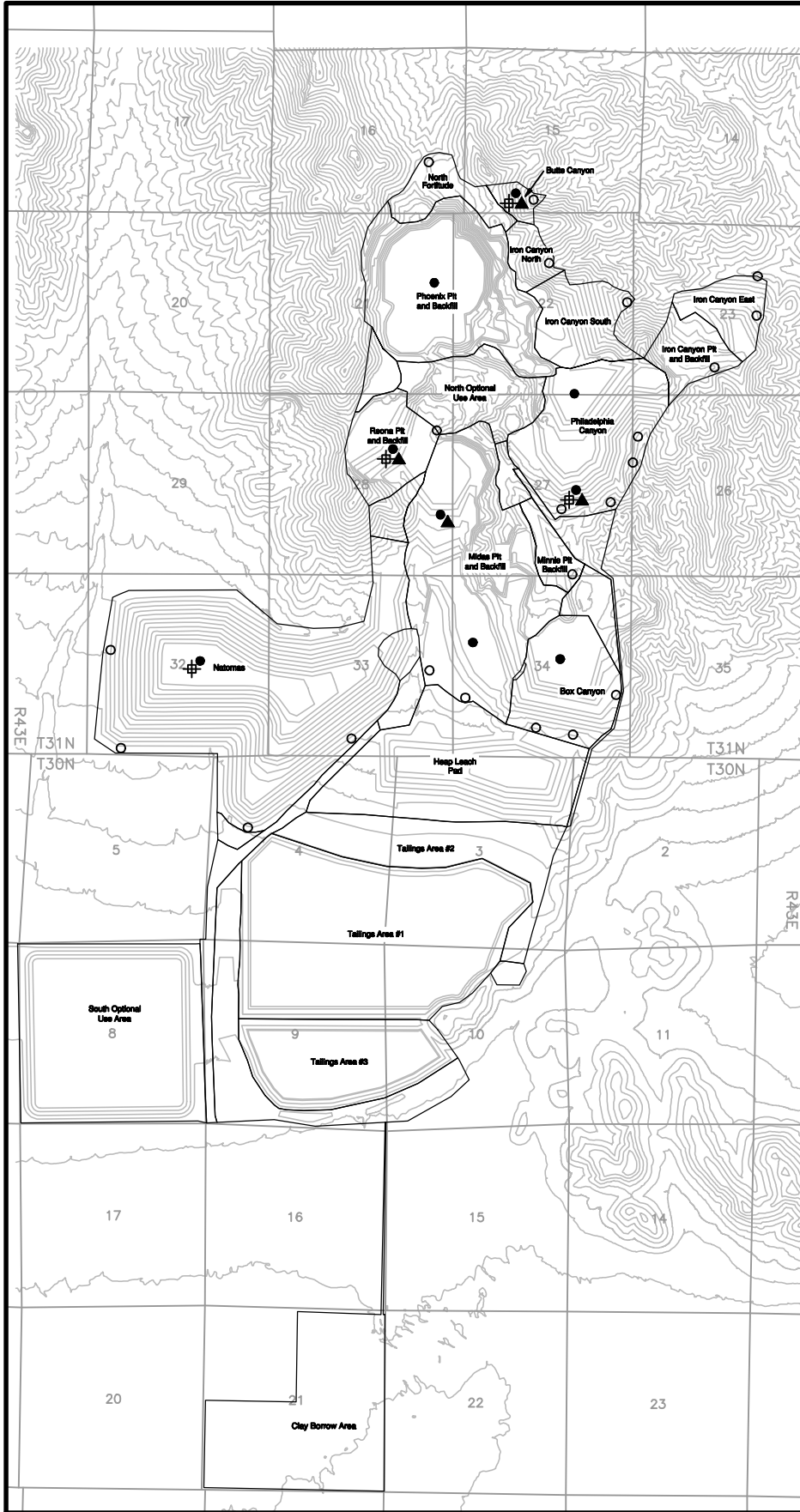

Explanation

- Cap Monitoring Location
- Toe Monitoring Location
- ⊕ Weather Station
- ▲ Runoff Plot

Source: Brown and Caldwell 2000c

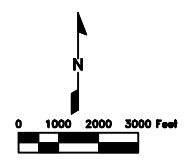

Phoenix Project
Figure 3.2-29
Proposed
Unsaturated Flow
Monitoring Locations

Long-term monitoring and contingent long-term ground water management are integral parts of the Proposed Action. The following additional monitoring and mitigation measures are recommended to further reduce or eliminate potential impacts to water resources from the Proposed Action.

WR-1: Long-term Monitoring. Numerical simulations indicate that a perennial segment of Willow Creek, several spring sites, and existing surface and ground water rights could be affected by mine-induced drawdown of regional ground water levels. BMG would be responsible for continued monitoring and reporting of changes in ground water levels and surface water flows, as specified in the Water Resources Monitoring Plan (Brown and Caldwell 2000e) in the postreclamation period. BMG would provide the monitoring results, describe any deviations from the original predictions, and propose modifications to the monitoring plan, if appropriate, in an annual report to both the Nevada Division of Water Resources and the BLM. The combined surface and ground water monitoring results would be used to trigger the implementation of measures WR-3 and WR-4 to mitigate impacts to surface water resources. Monitoring and reporting would continue until all impacts to water resources have been mitigated. Monitoring would cease with approval of both the Nevada Division of Water Resources and the BLM.

WR-2: Little Cottonwood Canyon Inventory and Monitoring. Prior to the initiation of mine dewatering, a baseline inventory would be performed to locate and characterize any perennial waters, including spring source areas and perennial stream reaches located in the south tributary of Little Cottonwood Canyon (Section 1, 2, and 3, Township 31 North, Range 43 East). The inventory would be performed during the low-flow period (late September through mid-October) to establish baseline flow and water quality conditions (major ion, trace elements, and isotope geochemistry). The inventory also would include site observations of hydrogeologic conditions, photographs, and description and mapping of wetland vegetation. Based on the results of the inventory, BLM or BMG **would add** additional representative spring(s) to BMG's surface water monitoring program, **if appropriate**. BMG's spring inventory and recommendations regarding additional spring monitoring would be submitted to the BLM for approval.

WR-3: Perennial Springs and Streams Flow. The comprehensive Water Resources Monitoring Plan (Brown and Caldwell 2000e) would be expanded to include all 10 spring sites included in **Table 3.2-14**, and at least three flow monitoring locations along the lower perennial reach of Willow Creek. Monitoring of these surface water resources would include annual flow measurements during the low-flow season (late September through mid-October). In addition, a stream gage coupled with a shallow ground water monitoring well, would be established to continuously monitor flows and shallow ground water elevations on Willow Creek. This monitoring station would be installed in the gaining perennial reach below the Willow Creek reservoirs between Baker Consultants, Inc. flow monitoring stations 10 and 11 (Baker Consultants, Inc. 1997a) (shown as BC-10 and BC-11 on **Figure 3.2-3**), or another approved location within this stream reach. If monitoring indicates that flow reductions have occurred and that these reductions are likely the result of mine-induced drawdown, the following measures would be implemented:

1. The Nevada Division of Water Resources and the BLM would evaluate the available information and determine if mitigation is required.
2. If mitigation is required, BMG would be responsible for preparing a detailed, site-specific plan to enhance or replace the impacted perennial water resources. **The mitigation plan would be submitted to the BLM and NDWR for review within 30 days of identifying drawdown impacts to surface water resources.** Mitigation would depend on the actual impacts and site-specific conditions and could include a variety of measures such as flow augmentation on-site or off-site surface water improvements, or other approved measures. Flow augmentation could be implemented to maintain flows and functional riparian and aquatic habitats at pre-project levels. The source of water for flow augmentation could include water piped from another nearby source or water supplied by a well drilled into an underlying aquifer near the affected spring or stream. Discharge from the well to the surface could be maintained by natural artesian flow, wind generation, or by an electric pump powered by commercial electricity or solar power generation. Other possible mitigation measures include a) improving existing stream or spring sites to enhance water yield collection and/or

3.0 AFFECTED ENVIRONMENT AND ENVIRONMENTAL CONSEQUENCES

b) developing or improving other nearby streams or springs to offset the loss in flow.

3. An approved site-specific mitigation plan would be implemented followed by monitoring and reporting to measure the effectiveness of the implemented measures.
4. If initial implementation were unsuccessful, the Nevada Division of Water Resources or the BLM **would** require implementation of additional measures, **if appropriate**.

WR-4: Water Rights. BMG would be responsible for monitoring ground water levels between the mine and water supply wells, ground water rights, and surface water rights as part of the comprehensive monitoring program. Adverse impacts to water wells and water rights would be mitigated, as required by the Nevada Division of Water Resources. For impacts to wells, mitigation could include lowering the pump, deepening an existing well, drilling a new well for water supply wells, or providing a replacement water supply of equivalent yield and general water quality. For surface water rights, mitigation could require providing a replacement water supply of equivalent yield and general water quality.

WR-5: Additional Long-term Water Quality Monitoring. The Water Resources Monitoring Plan (Brown and Caldwell 2000e) includes surface water and ground water quality monitoring. Under this monitoring plan, the duration of monitoring in the postmining period would depend on the requirements set forth in the NDEP Water Pollution Control Permit for the Phoenix Project. Under current Nevada regulations (NAC 445A.446), NDEP could require monitoring for up to, but not exceeding, 30 years after permanent closure of a facility. As stated in the impact assessment, there is a potential for infiltration through the waste rock facilities to impact ground water quality in the long-term (>30 years after permanent closure). The Contingent Long-term Groundwater Management Plan (Brown and Caldwell 2000c) is designed to prevent degradation of ground water quality in the postclosure period. In addition to the monitoring measures set forth in the Contingent Long-term Groundwater Management Plan, the BLM, in coordination with applicable state agencies, **would** require BMG to provide funding for additional monitoring of ground water quality in the postmining period. Long-term monitoring of ground water quality **would** be required to 1) assist in evaluating the need to implement the Contingent

Long-term Groundwater Management Plan, 2) verify that ground water quality has not been impacted, and/or 3) demonstrate that impacted ground water has been fully captured by the ground water management system. Specific details regarding supplemental ground water quality monitoring associated with the Contingent Long-term Groundwater Management Plan are provided in mitigation measure WR-6.

WR-6: Supplemental Measures to the Contingent Long-term Groundwater Management Plan (Brown and Caldwell 2000c). The Contingent Long-term Groundwater Management Plan specifies measures to monitor the unsaturated zone at the downgradient edge of each waste rock facility and to implement a response plan to capture and treat affected ground water, if necessary. The following additional monitoring and mitigation measures would supplement the Contingent Long-term Groundwater Management Plan.

1. If long-term unsaturated zone monitoring of water quality at the toe of a waste rock facility indicates that leachate from the facility is migrating downward beyond the depth of the unsaturated zone monitoring points, a site-specific ground water monitoring plan (including ground water monitoring locations, monitoring well design, sampling frequency, sample protocols, and reporting) would be developed, and submitted for approval by the BLM in coordination with applicable state agencies, within 60 days of detection.
2. After approval, the site-specific ground water monitoring system would be installed and maintained to monitor ground water quality immediately downgradient of the waste rock facility on at least an annual basis. The combined information from the unsaturated zone and ground water monitoring system would be used by the BLM, in coordination with applicable state agencies, to implement the ground water extraction and treatment system in specific areas, as necessary, to prevent impacts to ground water quality downgradient of the defined extraction points identified in the Contingent Long-term Groundwater Management Plan.
3. If extraction and treatment become necessary, additional monitoring would be implemented downgradient of the extraction wells to verify that the degraded water has been fully captured by the ground water extraction system.

4. Any unsaturated zone monitoring or ground water monitoring required would continue until the potential risk of ground water contamination has been shown to be minimal as determined by the BLM in coordination with other applicable agencies.

In addition, BMG and BLM would continue to evaluate other appropriate technologies for prevention of water quality impacts. Ground water quality impacts would be mitigated by either implementation of the measures defined in the Contingent Long-term Groundwater Management Plan or by other appropriate measures approved by the BLM in coordination with other applicable agencies.

WR-7: Minnie Pit. The Water Resources Monitoring Plan (Brown and Caldwell 2000e) would be expanded to include monitoring for water ponded in the existing Minnie Pit. If standing water is observed in the Minnie Pit prior to backfill, the backfill material placed in the potential ground water saturation zone would be amended with lime, limestone, or other suitable amendment to neutralize acid formed by ground water contact, to preclude ground water quality impacts from interaction of ground water with sulfide oxidation products formed from weathering of the backfilled waste rock material.

WR-8: Tailings (Supernatant) Pond Fluids. Fluids ponded on the tailings facilities could at times have a low pH and contain elevated trace metal concentrations that may be toxic to waterfowl and other wildlife. The following monitoring and mitigation measures would be used to mitigate potential impacts to waterfowl and other wildlife associated with the supernatant pond fluids. The pH of any ponded fluids contained within the tailings facilities **would** be monitored on a daily basis, and the water quality of the pond **would** be analyzed on a quarterly basis for NDEP's Profile II list of constituents. If deleterious supernatant pond water quality is detected, the pH of the fluids would be adjusted using chemical alkalinity additions (such as hydrated lime, milk of lime, or sodium hydroxide) to increase the pH and correspondingly reduce trace metal concentrations to non-toxic levels.

WR-9: Final Reclamation of Sediment Basins. Prior to capping and successful revegetation of the waste rock facilities, sediment basins located downstream of the waste rock facilities could collect runoff that is acidic and/or contains elevated metals concentrations. As

part of the final reclamation and closure activities, the chemical composition of sediment contained in the basins would be analyzed. If the sediment contains contaminants likely to degrade surface or ground water quality, the sediment would be excavated and disposed of either on-site or off-site in accordance with applicable state and federal regulations, in coordination with the NDEP and the BLM.

WR-10 Use of Waste Rock as Road Fill and Exposure of Waste Rock Material. Some waste rock material could generate acid rock drainage and impact surface or ground water quality. Therefore, all waste rock to be used as construction material (e.g., haul roads, pads) and older waste rock exposed in excavations for roads or facility areas would be sampled and analyzed in accordance with the Waste Rock Management Plan (Brown and Caldwell 2000d) to determine if they contain contaminants that are likely to become mobile and degrade surface or ground water. Only benign waste rock would be used as uncapped or uncovered construction fill, and older waste rock exposed during construction would be covered with a sufficient thickness of benign material to prevent impacts to storm water runoff quality.

WR-11: Surface Water Quality for Waste Rock Facilities. The Water Resources Monitoring Plan would be revised to include specific procedures to monitor surface water flow and field water quality parameters (including pH and conductivity) at monitoring locations Phx 1 through Phx-14 quarterly (if there is sufficient flow) and during runoff events. Modifications to the plan would include: (1) procedures to determine when runoff-event-driven sampling would be performed (based on precipitation and snow melt); (2) field water quality parameter thresholds to determine when water quality samples would be collected for laboratory analysis, and (3) laboratory analyses to be conducted (including a list of constituents to be analyzed), if necessary. The revised plan would be submitted to the NDEP and BLM for approval prior to project initiation.

3.2.5 Residual Adverse Effects

The placement of proposed waste rock facilities is predicted to reduce recharge and result in a cone of drawdown around the project site that extends up to 4 miles in an east-west direction and 5 miles

3.0 AFFECTED ENVIRONMENT AND ENVIRONMENTAL CONSEQUENCES

in a north-south direction in the Battle Mountain range (**Figure 3.2-16**). Successful implementation of mitigation measures would eliminate most residual adverse effects to water resources. However, a permanent reduction of surface discharge associated with drawdown would constitute a residual adverse effect.

No residual adverse effects on water quality or surface water flows, erosion, or sedimentation are anticipated from the Proposed Action with the implementation of monitoring and mitigation measures. Geochemical modeling (Exponent 2000a) suggests that the No Action alternative could potentially result in long-term residual impacts to ground water quality.