



Engineering at NSF

NSF Regional Grants Conference

Tempe, Arizona

March 30 – 31, 2009

Robert L. Smith

Program Director

Division of Civil, Mechanical and
Manufacturing Innovation

National Science Foundation





Presentation Outline

- ◎ Overview of NSF
- ◎ Directorate for Engineering Research Footprint
 - > Research Themes
 - > Organizational Structure and Division Programs
- ◎ Funding Opportunities
 - > Programs
 - > Initiatives
- ◎ Successful Proposals



- The National Science Foundation (NSF) is an independent federal agency created by Congress in 1950
- The Charge was and is *"to promote the progress of science; to advance the national health, prosperity, and welfare; to secure the national defense..."*
- Has an annual budget of approximately **\$6 billion**
- NSF is the funding source for approximately **20 percent** of all federally supported basic research conducted by America's colleges and universities
- In many fields such as mathematics, computer science and the social sciences, NSF is the major source of federal backing





NSF Budget 2002-2008

(Dollars in Millions)

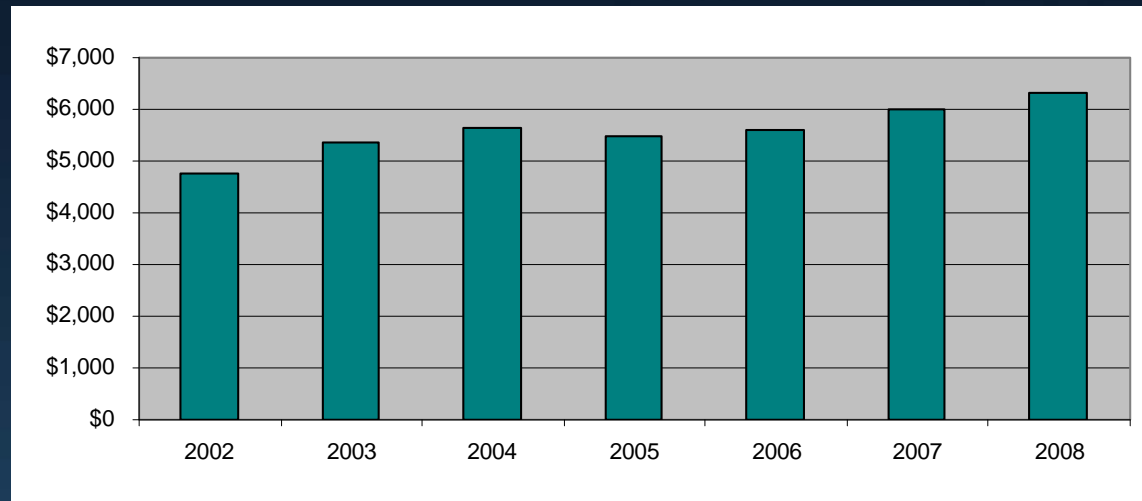

Engineering Directorate FY 2008 budget: \$660 Million (10.4% of NSF budget)



NSF Organizational Chart

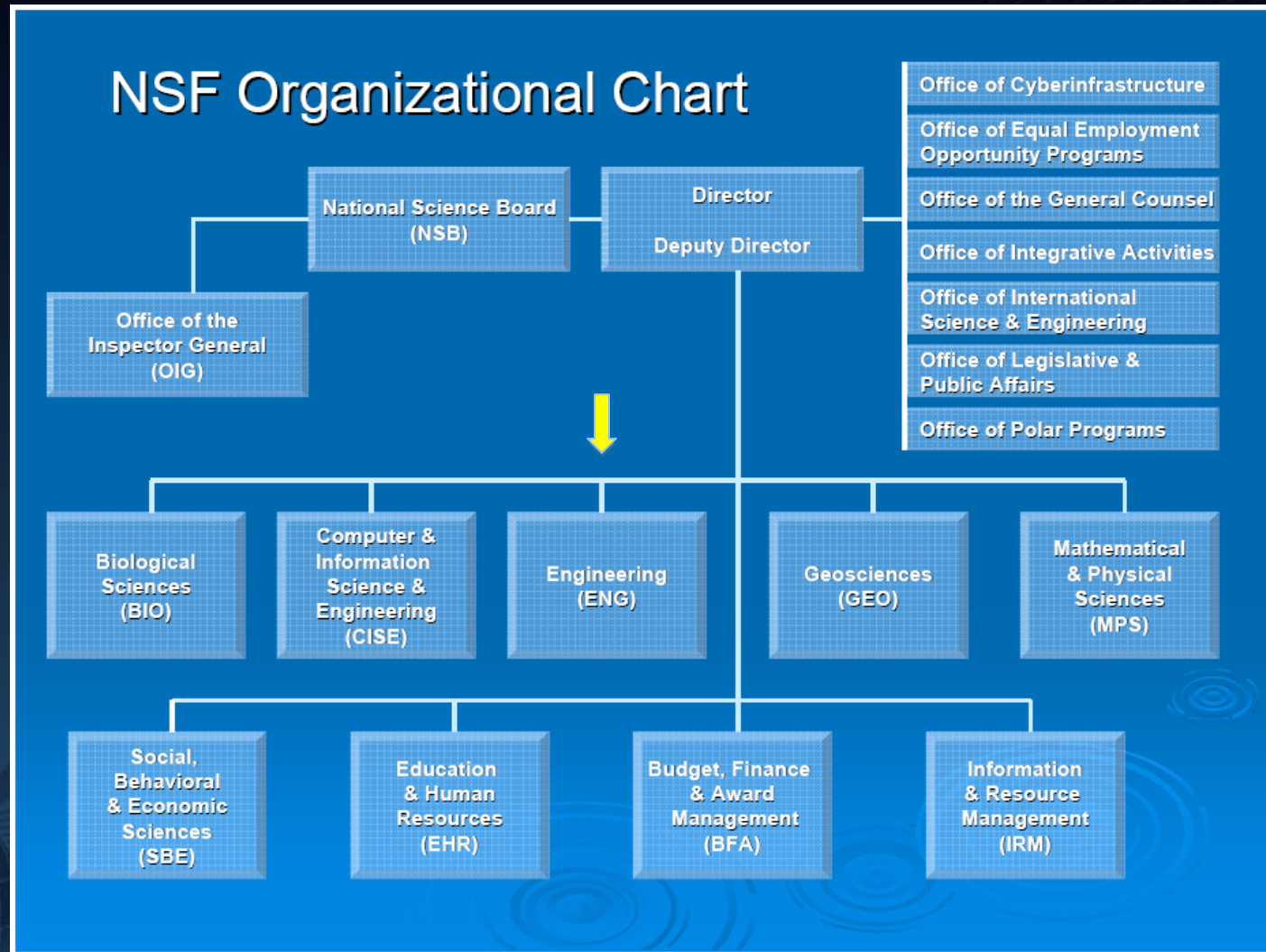



NSF Budget by Research Directorate

Dollars in Millions

Directorate	FY 2007 Actual	FY 2008 Estimate	FY 2009 Request	FY 2009 Request			
				Change over FY 2007 Actual		Change over FY 2008 Estimate	
				Amt	%	Amt	%
BIO	\$608.54	\$612.02	\$675.06	\$66.52	10.9	\$63.04	10.3
CISE	526.68	534.53	638.76	112.08	21.3	104.23	19.5
ENG (less SBIR/STTR)	521.33	527.50	632.33	111.00	21.3	104.83	19.9
SBIR/STTR	108.67	109.37	127.00	18.33	16.9	17.63	16.1
GEO	745.85	752.66	848.67	102.82	13.8	96.01	12.8
MPS	1,150.73	1,167.31	1,402.67	251.94	21.9	235.36	20.2
SBE	214.54	215.13	233.48	18.94	8.8	18.35	8.5
OCI	182.42	185.33	220.08	37.66	20.6	34.75	18.8
OISE	40.36	41.34	47.44	7.08	17.6	6.10	14.8
OPP	438.43	442.54	490.97	52.54	12.0	48.43	10.9
IA	219.45	232.27	276.00	56.55	25.8	43.73	18.8
U.S. Arctic Research Commission	1.45	1.47	1.53	0.08	5.5	0.06	4.1
Research & Related Activities	\$4,758.44	\$4,821.47	\$5,593.99	\$835.55	17.6%	\$772.52	16.0%



Directorate for Engineering

Research and Education Themes

Engineering research spans the frontiers

- To support fundamental research and education, **ENG identifies research and education themes.**
- The **five themes** represent a convergence of fields, disciplines, and frontier research opportunities that cut across divisions, and provide general guidance on **potential future directions of engineering research.**
- **Themes will evolve over time**, reflecting the maturation of certain fields, the emergence of new fields, and engineering's crucial role in addressing increasingly complex challenges, touching every sector of society.

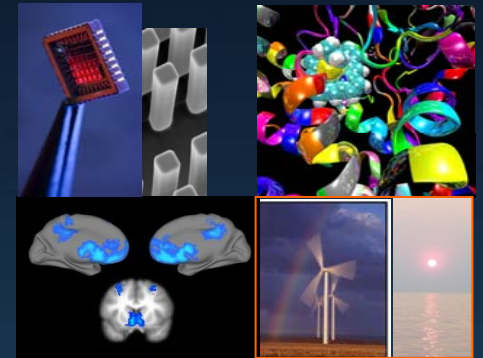

Engineering contributes at all scales. Examples are nanotechnology, computational simulation, health, and alternate energy.



Current ENG Research and Education Themes

- ◉ **Cognitive engineering**: Intersection of engineering and cognitive sciences
- ◉ **Competitive manufacturing and service enterprises**
- ◉ **Complexity** in engineered and natural systems
- ◉ **Energy, water, and the environment**
- ◉ **Systems nanotechnology**



Cognitive Engineering

Invests in improving understanding of the brain and nervous system to enable the engineering of novel systems and machines

- Examples include:
 - > Devices that augment the senses
 - > Intelligent machines that analyze and adapt

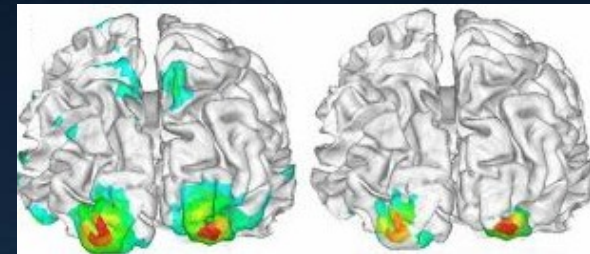

Combining EEG with functional MRI data (left image is EEG, right image shows both) enables precise mapping of brain activity. *He, 0411898.*



Competitive Manufacturing and Service Enterprises

Enables research to catalyze multiscale manufacturing, from fundamental metrology through atomic-scale control of raw materials

- Examples include:
 - > Developing quality-engineered nanomaterials in necessary quantities
 - > Achieving perfect atomic- and molecular-scale manufacturing



Nanoparticles compose a lightweight biocompatible material for bone implants.
Groza, 0523063.



Complexity in Engineered and Natural Systems

Addresses unifying principles that enable modeling, prediction, and control of emergent behavior in complex systems

- Examples include:
 - > Improving structural performance during disasters through advanced materials
 - > Advancing quantum information processing

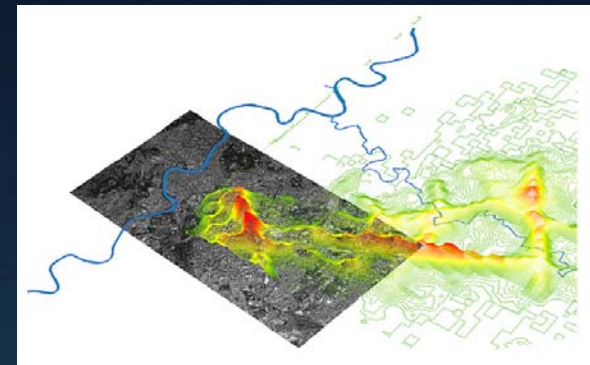

Combining maps (gray square) and density of cell-phone usage (shown as red and yellow 3-D peaks) can yield information about how a complex system responds to unplanned events. *Dahleh, 0735956*.



Energy, Water, and the Environment

Supports breakthroughs essential to the provision of energy and water in an environmentally sustainable and secure manner.

- Examples include:
 - Increasing the use of alternative energy sources through research in materials
 - Developing quantitative understanding of energy–environment interactions (including water)

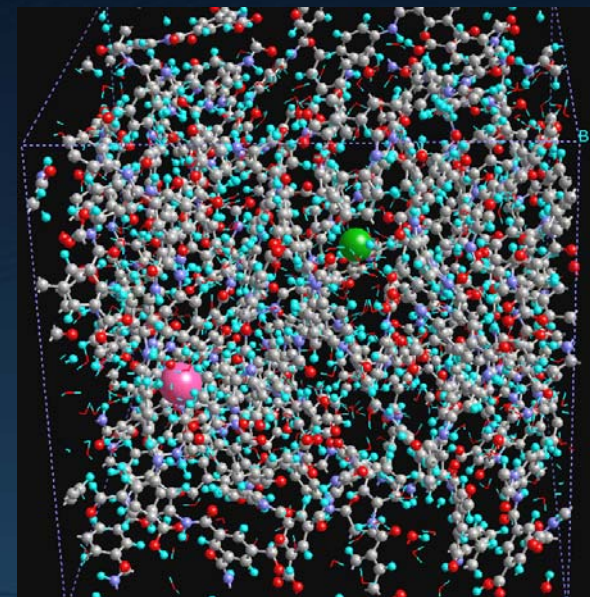

Advanced water purification and desalination begins with understanding of how ions in water interact with purification membranes. This dynamic computer simulation shows sodium (pink) and chlorine (green) ions inside a polyamide membrane. *Shannon, 0120978.*



Systems Nanotechnology

Supports fundamental research that leads to the development of active and complex nanosystems and their integration with biology, energy, and other fields

○ Examples include:

- > Developing high-specificity sensors for national security
- > Developing tools to move into the 3rd dimension and into time resolutions of chemical reactions

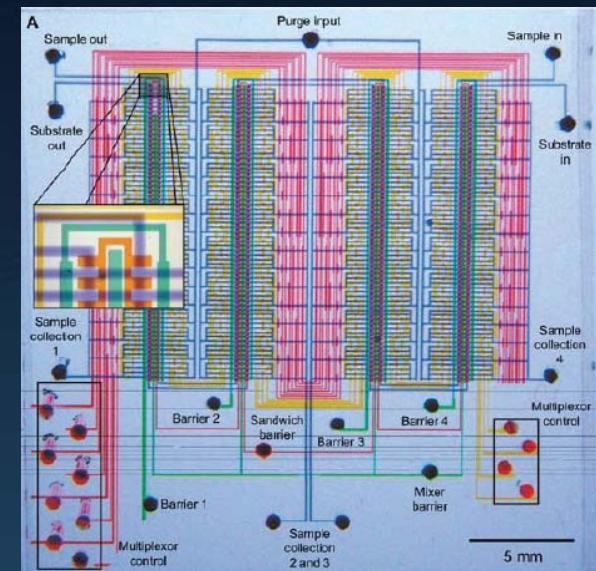

Integrated circuits that are smaller and faster are possible with microfluidics systems built from or incorporating nanocomponents. *Ferreira, 0328162.*



ENG Organizational Structure & Division Programs

Credit: Top Row: John C. Phillips photo/ASU Research Magazine; Microsoft; Microsoft; Microsoft; Microsoft; Microsoft; Microsoft. Middle Row: Microsoft; Microsoft; Kellar Autumn, Lewis and Clark College; Microsoft; NASA. Bottom Row: Raymond A. Adomaitis, University of Maryland - College Park; Microsoft; Kalinichev, A.G. and Kirkpatrick, R.J., University of Illinois at Urbana-Champaign; Microsoft; Microsoft.



ENG Organization

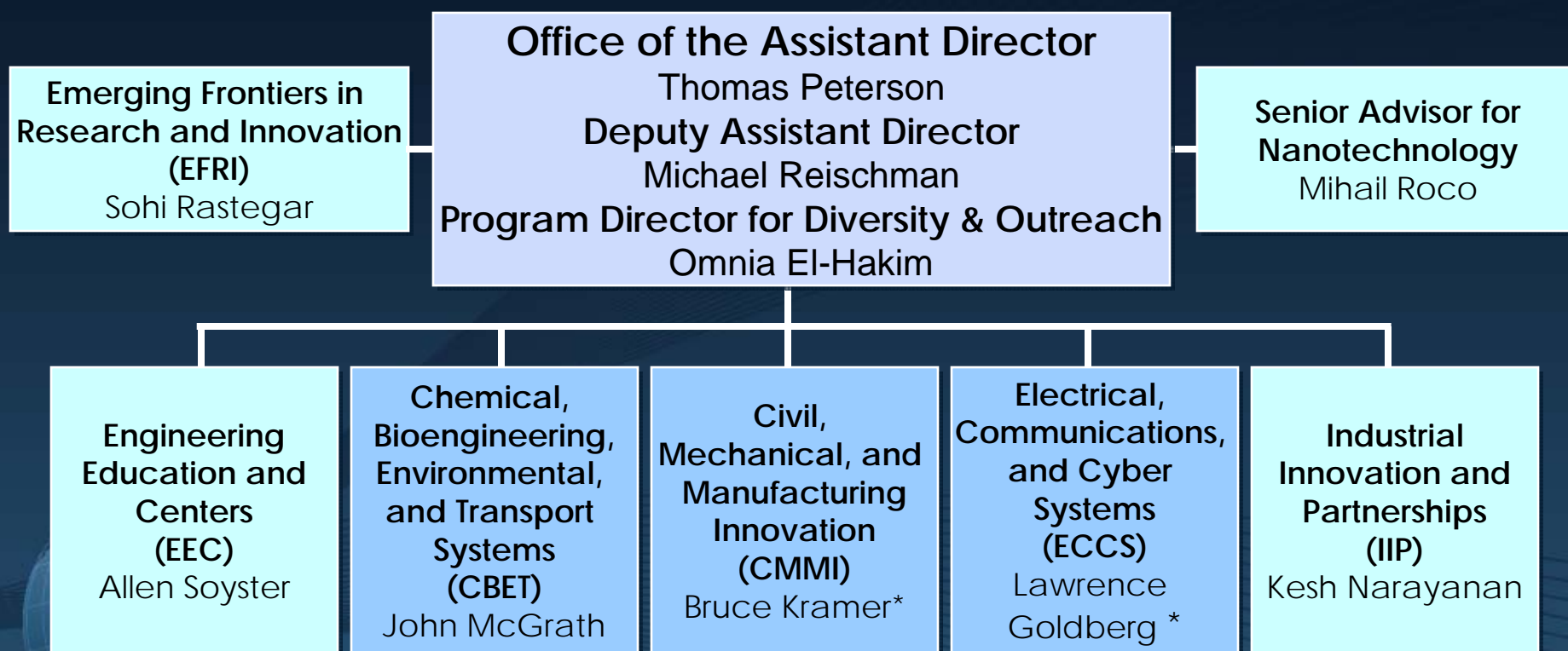

* Acting



ENG Disciplinary Divisions

- **Chemical, Bioengineering, Environmental, and Transport Systems (CBET)**
- **Civil, Mechanical, and Manufacturing Innovation (CMMI)**
- **Electrical, Communications, and Cyber Systems (ECCS)**



Chemical, Bioengineering, Environmental, and Transport Systems (CBET)

Deputy Division Director
Bob Wellek

Division Director
John McGrath

Senior Advisor
Marshall Lih

Chemical, Biochemical, and Biotechnology Systems

Catalysis and Biocatalysis
John Regalbuto

Chemical and Biological Separations
Rose Wesson

Process and Reaction Engineering
Maria Burka

Biotechnology, Biochemical, and Biomass Engineering
Fred Heineken

Biomedical Engineering and Engineering Healthcare

Bioengineering, Interdisciplinary, and Centers
Aleksandr Simonian

Biomedical Engineering
Semahat Demir

Biophotonics, Advanced Imaging, and Sensing for Human Health
Leon Esterowitz

Research to Aid Persons with Disabilities
Ted Conway

Environmental Engineering and Sustainability

Energy for Sustainability
Trung Van Nguyen

Environmental Engineering
Clark Liu

Environmental Implications of Emerging Technologies
Paul Bishop

Environmental Sustainability
Bruce Hamilton

Environmental Technology
Cynthia Ekstein

Transport and Thermal Fluids

Thermal Transport Processes
Theodore Bergman

Interfacial Processes and Thermodynamics
Bob Wellek

Particulate and Multiphase Processes
Marc Ingber

Fluid Dynamics
Bill Schultz

Combustion, Fire, and Plasma Systems
Phil Westmoreland



CBET Areas of Interest

- **Chemical, biochemical, and biotechnology:** research on the processing and manufacture of products by effectively utilizing chemical and renewable resources, often with the aid of bioinformatics from genomic and proteomic information
- **Biomedical engineering and engineering healthcare:** research to develop novel projects that integrate engineering and life science to solve biomedical problems that serve humanity
- **Environmental engineering and sustainability:** research that aims to reduce adverse effects of solid, liquid, and gaseous discharges into land, water, and air that result from human activity and impair the ecological value of those resources
- **Transport and thermal fluids phenomena:** research on thermal, mass, and momentum transport that enable new technological solutions to understand pressing issues in energy, the environment, manufacturing, health care, and other fields
- Two submission deadlines per year: Sept. 15 and Mar. 1



Civil, Mechanical, and Manufacturing Innovation (CMMI)

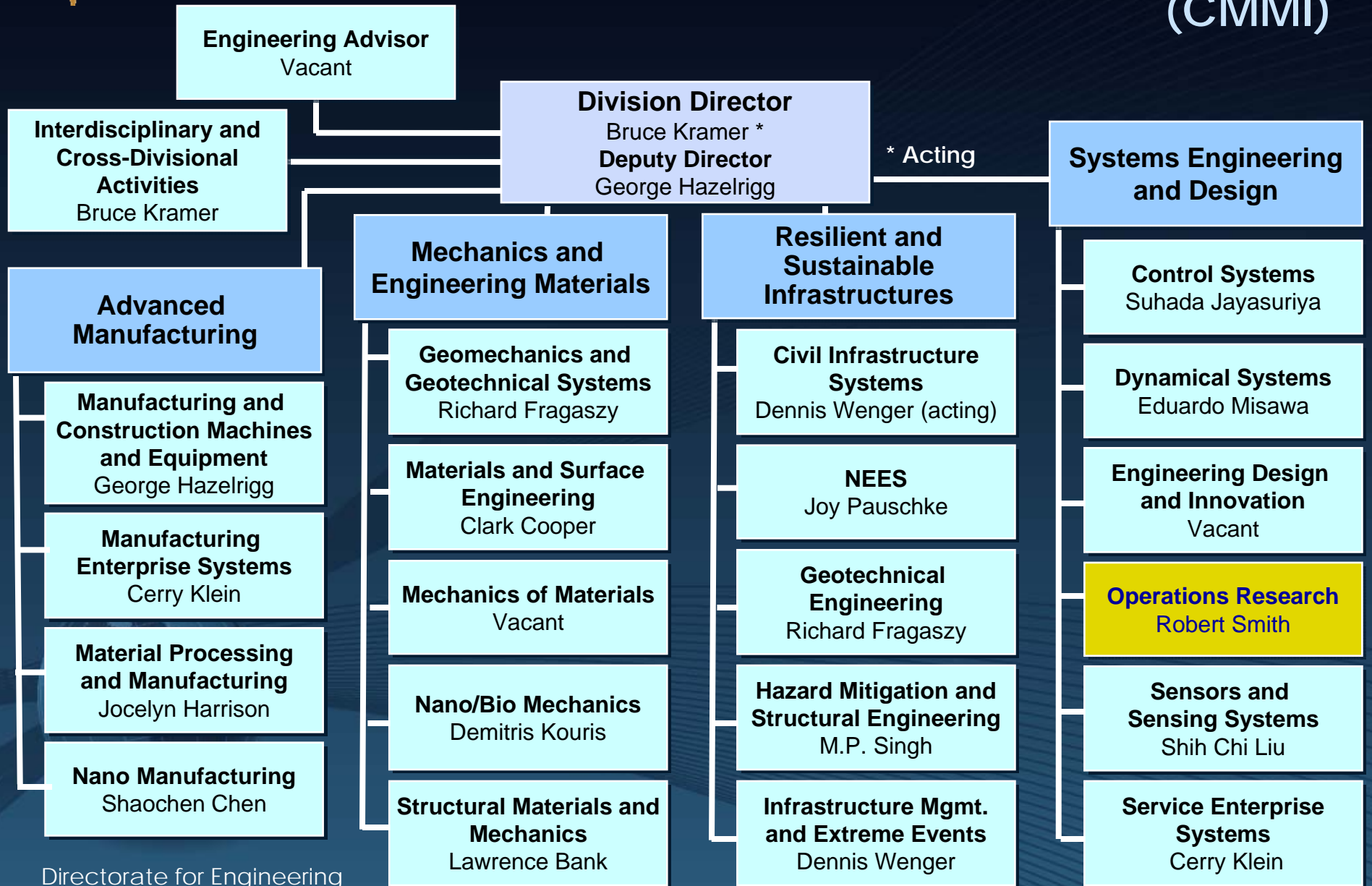



CMMI Areas of Interest

- **Advanced manufacturing:** research leading to transformative advances in manufacturing and building technologies, with emphases on efficiency, economy, and sustainability
- **Mechanics and engineering materials:** research aimed at advances in the transformation and use of engineering materials efficiently, economically, and sustainably
- **Resilient and sustainable infrastructures:** research to advance fundamental knowledge and innovation for resilient and sustainable civil infrastructure and distributed infrastructure networks
- **Systems engineering and design:** research on the decision-making aspects of engineering, including design, control, and optimization
- Two submission deadlines each year: Oct. 1 and Feb. 15



Electrical, Communications, and Cyber Systems (ECCS)

Senior Engineering Advisor
Lawrence Goldberg

Acting Division Director
Lawrence Goldberg

Electronics, Photonics, and Device Technologies

Optoelectronics; Nano-photonics; Ultrafast/Extreme Ultra-Violet Technologies
Eric Johnson

Micro/Nanoelectronics; NEMS/MEMS; Bioelectronics; Sensors
Vacant

Molecular, Spin, Organic, and Flexible Electronics; Micro/Nanomagnetics; Power Electronics
Pradeep Fulay

Microwave Photonics; Millimeter, Sub-millimeter and Terahertz Frequency Devices and Components
Usha Varshney

Integrative, Hybrid, and Complex Systems

Optical, Wireless, and Hybrid Communications Systems; Inter and Intra-chip Communications; Mixed Signals
Andreas Weisshaar

Micro and Nano Systems; Systems-on-a-chip; Diagnostic and Implantable Systems
Yogesh Gianchandani

Cyber-Physical Systems; Next-Generation Cyber Systems; Signal Processing
Scott Midkiff

Power, Controls, and Adaptive Networks

Embedded, Distributed and Adaptive Control; Sensing and Imaging Networks; Systems Theory; Telerobotics
Radhakishan Baheti

Power and Energy Systems and Networks and their Interdependencies; Power Drives; Renewable/Alternative Energy Sources
Dagmar Niebur

Adaptive Dynamic Programming; Quantum and Molecular Modeling and Simulations; Neuromorphic Engineering
Paul Werbos



ECCS Areas of Interest

Electronics, Photonics, and Device Technologies EPDT

- ✓ Bioelectronics
- ✓ Electromagnetics
- ✓ Flexible Electronics
- ✓ MEMS/NEMS
- ✓ Micro/Nanoelectronics
- ✓ Micro/Nanomagnetics
- ✓ Microwave Photonics
- ✓ Molecular Electronics
- ✓ Nanophotonics
- ✓ Optoelectronics
- ✓ Power Electronics
- ✓ Sensors and Actuators
- ✓ Spin Electronics

Integrative, Hybrid, and Complex Systems IHCS

- ✓ Nanosystems/Microsystems/
Macrosystems
- ✓ Cyber Systems and Signal Processing
- ✓ Nano and Microsystems
 - ✓ System-on-a-chip
 - ✓ System-in-a-package
- ✓ RF and Optical Wireless and Hybrid
Communications Systems
 - ✓ Inter- and Intra-chip Communications
 - ✓ Mixed Signals

Power, Controls, and Adaptive Networks PCAN

- ✓ Adaptive Dynamic
Programming
- ✓ Alternate Energy Sources
- ✓ Embedded, Distributed and
Adaptive Control
- ✓ Neuromorphic Engineering
- ✓ Power and Energy Systems and
Networks
- ✓ Quantum and Molecular
Modeling and Simulation of
Devices and Systems
- ✓ Sensing and Imaging Networks
- ✓ Telerobotics



Funding Opportunities

- ◉ Core programs
- ◉ Exploratory and urgent research
- ◉ Collaborative/interdisciplinary areas
- ◉ Crosscutting and NSF-wide programs





ENG Core Programs

- ◎ ENG division programs
- ◎ Faculty Early Career Development (CAREER)
- ◎ Broadening Participation



Proposals to **ENG** Division Programs

- Proposals may be unsolicited or in response to a solicitation
- Submission windows and processes vary by division
- Awards are typically \$270 - \$330K for three years





Faculty Early Career Development (**CAREER**) Program

- Supports junior faculty who exemplify the role of teacher-scholars through
 - > outstanding research
 - > excellent education
 - > integration of education and research
- \$80M invested each year for 425 new awards
- ENG awards are \geq \$400K for 5 years
- Deadlines vary by directorate;
ENG proposals due July 22, 2009

ENG Contact
Sharon Middledorf



ENG CAREER Proposals and Awards

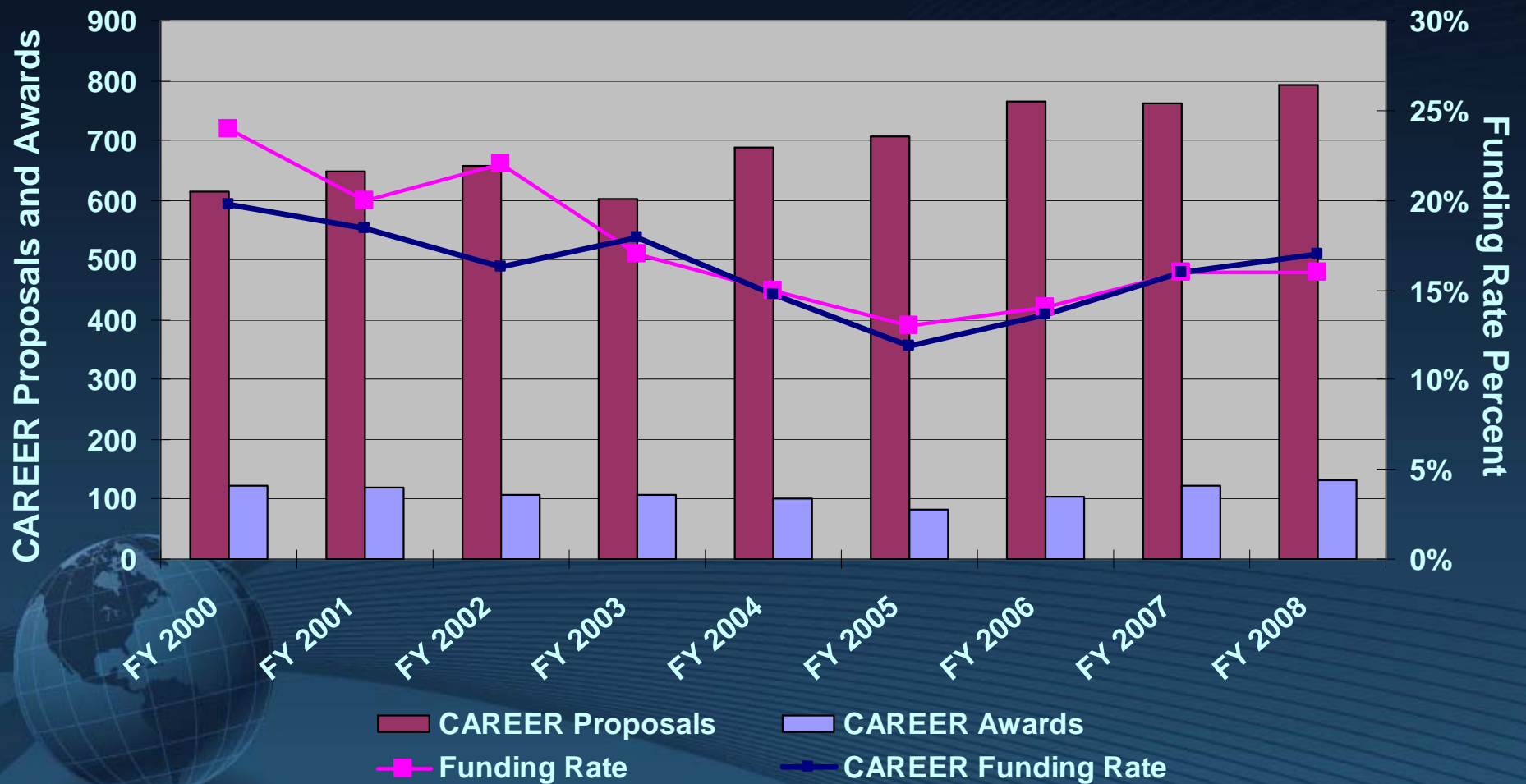



Broadening Participation

- ◉ Broadening Participation Research Initiation Grants in Engineering (**BRIGE**)
- ◉ **ADVANCE**: Increasing the Participation and Advancement of Women in Academic Science and Engineering Careers
- ◉ Graduate Research Supplements (**REU and RET**)



REU and RET Supplements to Existing Awards

- Research Experiences for Undergraduates (REU)
 - > Supports the involvement undergraduates in meaningful ways in ongoing research programs or in research projects specifically-designed for the REU program
 - > \$10M/year available for engineering
 - > Deadlines in Sept. and Aug. each year
- Research Experiences for Teachers (RET) in Engineering
 - > Supports the active involvement of K-12 teachers and community college faculty in engineering research in order to bring knowledge of engineering and technological innovation into their classrooms
 - > \$4M/year available
 - > Deadlines in June and Nov. each year



Funding Opportunities

- Core programs
- **Exploratory and urgent research**
- Collaborative/interdisciplinary areas
- Crosscutting and NSF-wide programs





Exploratory and Urgent Research

- ◉ Early-Concept Grants for Exploratory Research (**EAGER**)
- ◉ Grants for Rapid Response Research (**RAPID**)
- ◉ Emerging Frontiers in Research and Innovation (**EFRI**)





Early-Concept Grants for Exploratory Research (**EAGER**)

- Supports high-risk, exploratory, and potentially transformative research
- Begins Jan. 1, 2009
- Up to \$300K over two years
- May be submitted any time; contact program officer prior to proposal submission



Grants for Rapid Response Research (RAPID)

- Supports research of great urgency with regard to data, facilities, or equipment, such as research on disasters
- Up to \$200K over one year
- May be submitted any time; contact program officer prior to proposal submission



Emerging Frontiers in Research and Innovation (EFRI)

- Supports higher-risk, higher-payoff opportunities that:
 - > Are potentially transformative
 - > Address a national need or grand challenge
- Topic areas for FY 2009 are:
 - > BioSensing and BioActuation: Interface of Living and Engineered Systems (BSBA)
 - > Hydrocarbons from Biomass (HyBi)
- New topic areas announced in Spring
- \$25M investment for 4-year awards at \$500K per year
- Each year: Letters of Intent due in Oct.; preliminary proposals due in Dec.; invited full proposals due in April
- EFRI Web site: www.nsf.gov/eng/efri

EFRI
Sohi Rastegar



Funding Opportunities

- Core programs
- Exploratory research
- **Collaborative/interdisciplinary areas**
- Crosscutting and NSF-wide programs





ENG Collaborative and Interdisciplinary Research

- Engineering Education and Centers
- Industrial Innovation and Partnerships



Engineering Education and Centers (EEC)

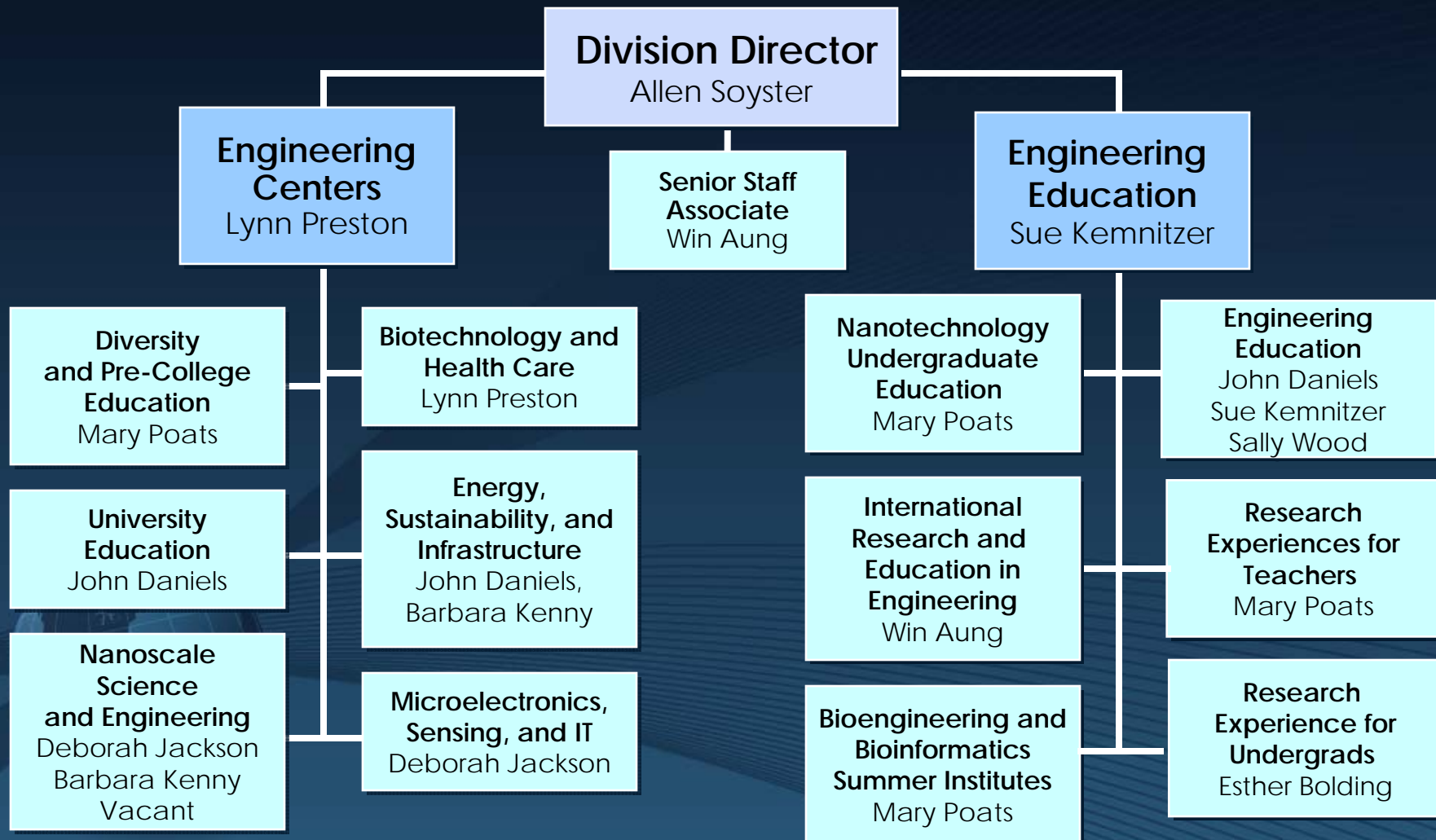



Engineering Centers

- Supports collaboration with industry to promote innovative research and education
- Engineering Research Centers
 - › 15 in operation, including 5 new for 2008
 - Funding for 10 years
 - › 2-year process from solicitation to funding
 - › New solicitation in early 2009
- Nanoscale Science and Engineering Centers
 - › 6 of 10 are engineering
 - › 2007 solicitation to establish a Center for the Environmental Implications of Nanotechnology



NSF-wide Education Programs

- Integrative Graduate Education and Research Traineeship (IGERT)
 - > ~20 awards each year
 - > Pre-proposals due in March, full proposals due in Sept.
- Graduate Teaching Fellows in K-12 Education (GK-12)
 - > ~20 awards each year
 - > Letters of Intent due in May, full proposals due in June
- Graduate Research Fellowships (GRF)
 - > ~1000 fellowships awarded each year
 - > Engineering and interdisciplinary proposals due in Nov. each year



Industrial Innovation and Partnerships (IIP)

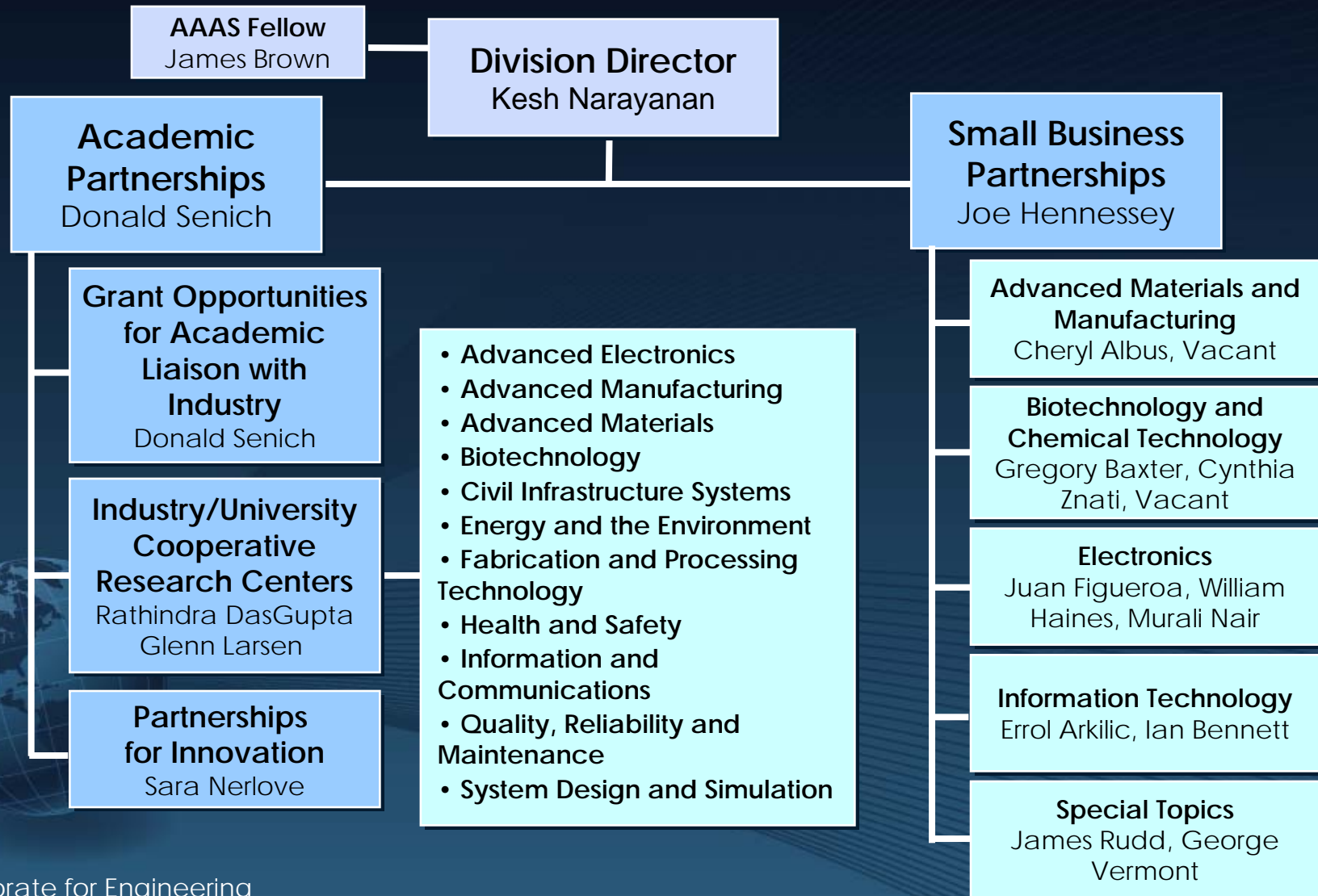



Grant Opportunities for Academic Liaison with Industry (**GOALI**)

- Effectively promotes the transfer of knowledge between academe and industry, student education, and the exchange of culture
- Supports:
 - Faculty and students in industry (≤ 1 year)
 - Industry engineers/scientists in academe (≤ 1 year)
 - Industry-university collaborative projects (≤ 3 years)
- \$5M available for co-funding with all NSF Directorates
- Proposals accepted anytime; ~70 awards each year



Industry/University Cooperative Research Center (I/UCRC) Program

- I/UCRC promotes long-term partnerships among industry, academe, and government
- Centers are catalyzed by a small investment from NSF and are primarily supported by industry center members during their development and evolution
- ~\$9M for 2-8 full center awards (\$55-80K/year for up to 5 years) and 4-12 planning grant awards (\$10K for 1 year)
- Two windows per year: Letters of Intent due in Jan. and June; full proposals due in March and Sept.



Small Business Innovation Research (SBIR) Programs

- ◉ Encourages small firms to undertake cutting-edge research with the potential for significant economic and public benefits
- ◉ Supports
 - › Biotechnologies and chemical technologies
 - › Electronics, components, and engineering systems
 - › Software and services
- ◉ \$25M for 170–250 awards
- ◉ Full proposals due in June and Dec.



Small Business Technology Transfer (**STTR**) Programs

- Encourages small firms to undertake cutting-edge research with the potential for significant economic and public benefits
- Enables university researchers to spin off commercially promising ideas while remaining employed primarily at the research institution
- Supports multi-functional materials
- \$5M for ~35 awards
- Letters of Intent due Jan. 14, 2009; full proposals due Feb. 25, 2009



Funding Opportunities

- Core programs
- Exploratory research
- Collaborative/interdisciplinary areas
- **Crosscutting and NSF-wide programs**





Crosscutting and NSF-wide Opportunities

- Cyber-Enabled Discovery and Innovation (CDI)
- Cyber-Physical Systems (CPS)
- Deep Underground Science and Engineering Laboratory (DUSEL S4)
- Domestic Nuclear Detection Office/NSF Academic Research Initiative (ARI)
- Major Research Instrumentation (MRI) Program
- Pan-American Advanced Studies Institutes Program (PASI)
- Partnerships for International Research and Education (PIRE)



Cyber-Enabled Discovery and Innovation (CDI)

- CDI is a five-year initiative to create revolutionary science and engineering research outcomes made possible by innovations and advances in **computational thinking**
- Seeks proposals within or across the following three thematic areas:
 - > Building Virtual Organizations
 - > From Data to Knowledge
 - > Understanding Complexity in Natural, Built, and Social Systems
- ~\$26M investment in 2008 for up to 30 grants
- Preliminary proposals due Dec. 8/9, 2008; full proposals due May 20, 2009

In ENG
Maria Burka
Eduardo Misawa



Domestic Nuclear Detection Office/NSF Academic Research Initiative (ARI)

- Focused on detection systems, individual sensors or other research for the detection of nuclear weapons or material, radiation dispersal devices, and related threats
- Possible topics include:
 - > Detector materials, concepts and designs for new sensors and sensing systems
 - > Non-intrusive active interrogation systems; particle generators and accelerators, associated detectors, and algorithms for improved data analysis
 - > Nuclear forensics and attribution
- 7–8 awards for up to \$400K annually per award for up to five years
- Full proposals due April 1, 2009

In ENG
Suhada Jayasuriya



Major Research Instrumentation (MRI) Program

- Goals of the program are to:
 - > Support the acquisition or development of major state-of-the-art instrumentation
 - > Improve access to and increase use of modern research and research training instrumentation
 - > Enable the creation of well-equipped learning environments that integrate research with education
 - > Foster the development of the next generation of instrumentation
 - > Promote partnerships
- ~\$110M investment for approximately 225 awards
- Letters of Intent due in Dec.; full proposals due Jan. 22, 2009

In ENG
Lawrence Goldberg



Partnerships for International Research and Education (PIRE)

- Seeks to catalyze a cultural change in U.S. institutions by establishing innovative models for international collaborative research and education
- Other objectives include to:
 - Provide international research experiences for U.S. students and faculty
 - Build strong international partnerships
 - Develop new replicable models for international collaborative research and education
 - Raise the profile and increase the importance of international collaborative research and education
- Preliminary proposals due Feb. 26, 2009

**Office of International
Science and
Engineering**
Elizabeth Lyons



Successful Proposals





ENG and SBIR/STTR Budgets (\$M)

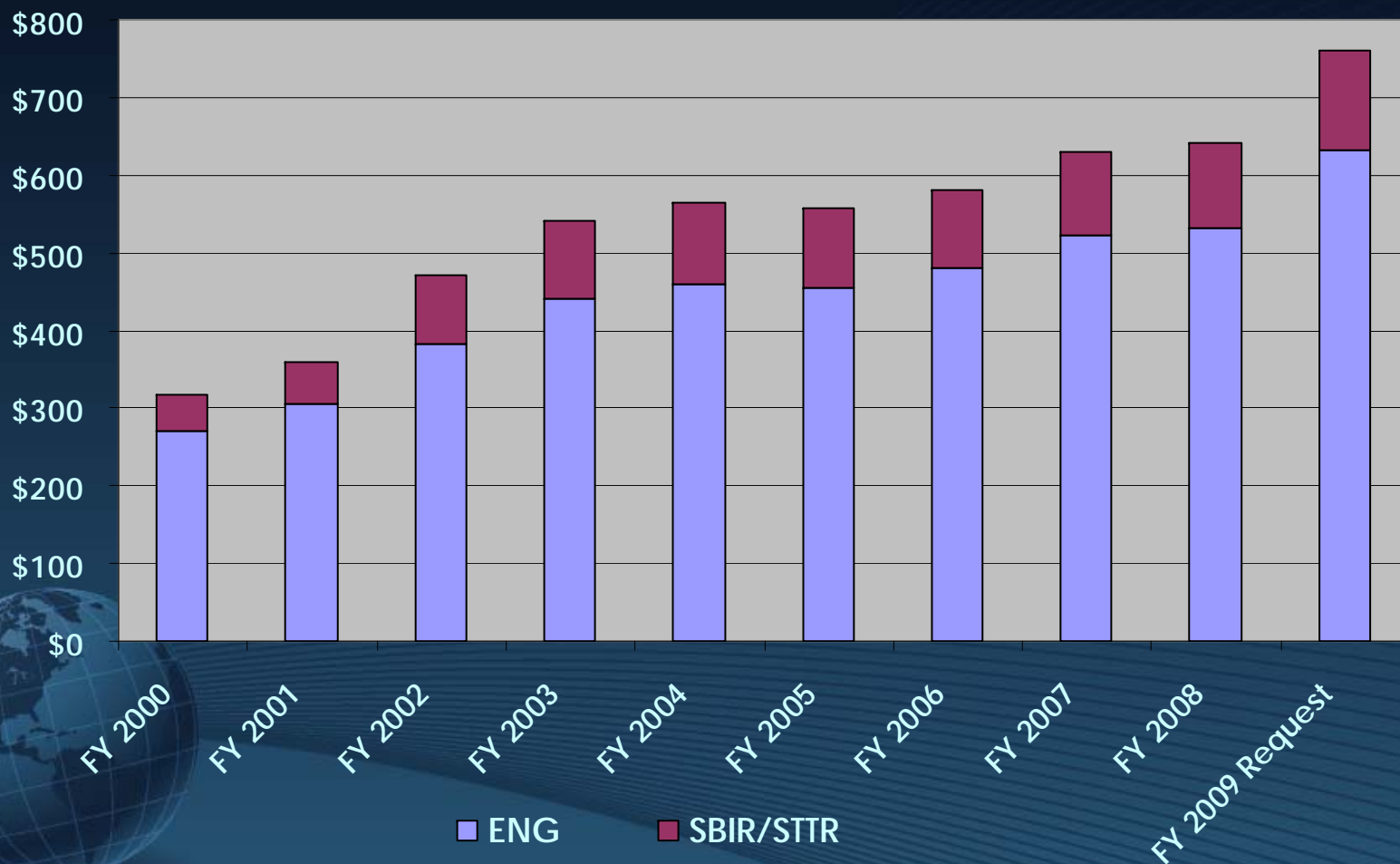



ENG Research Grant Proposals and Awards

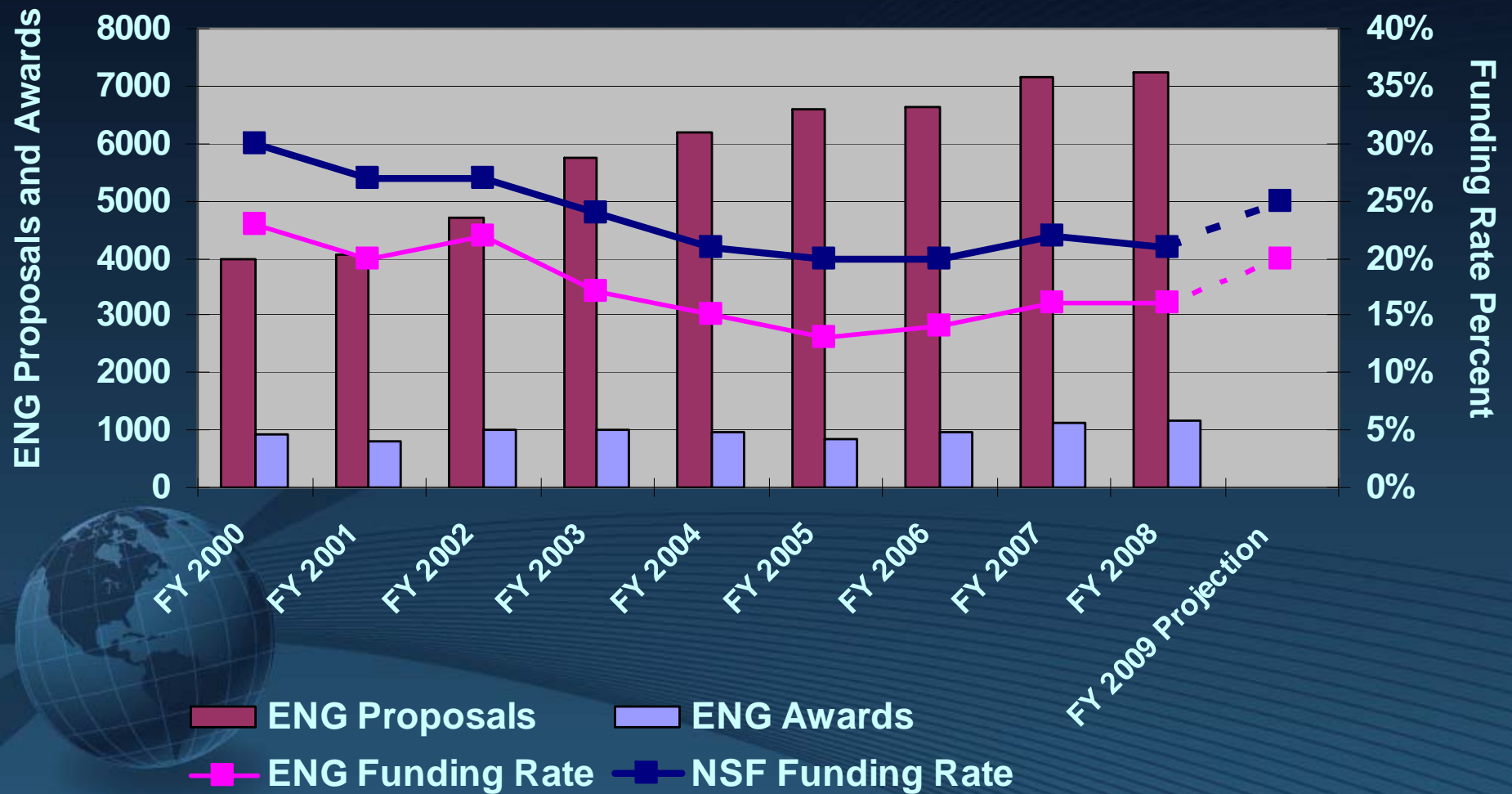



ENG Funding Rates for Prior and New PIs

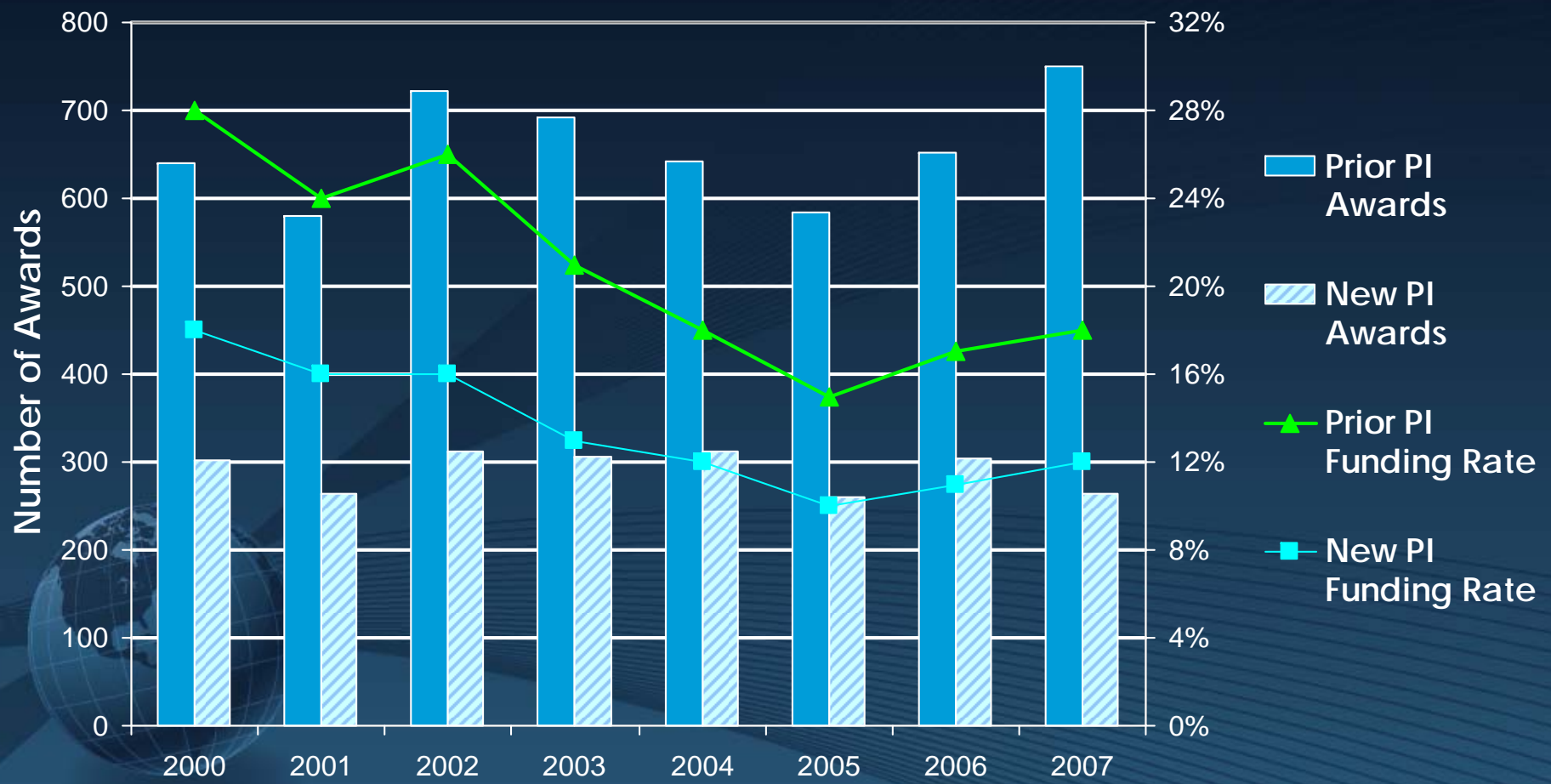



Single vs. Multiple Investigator ENG Awards

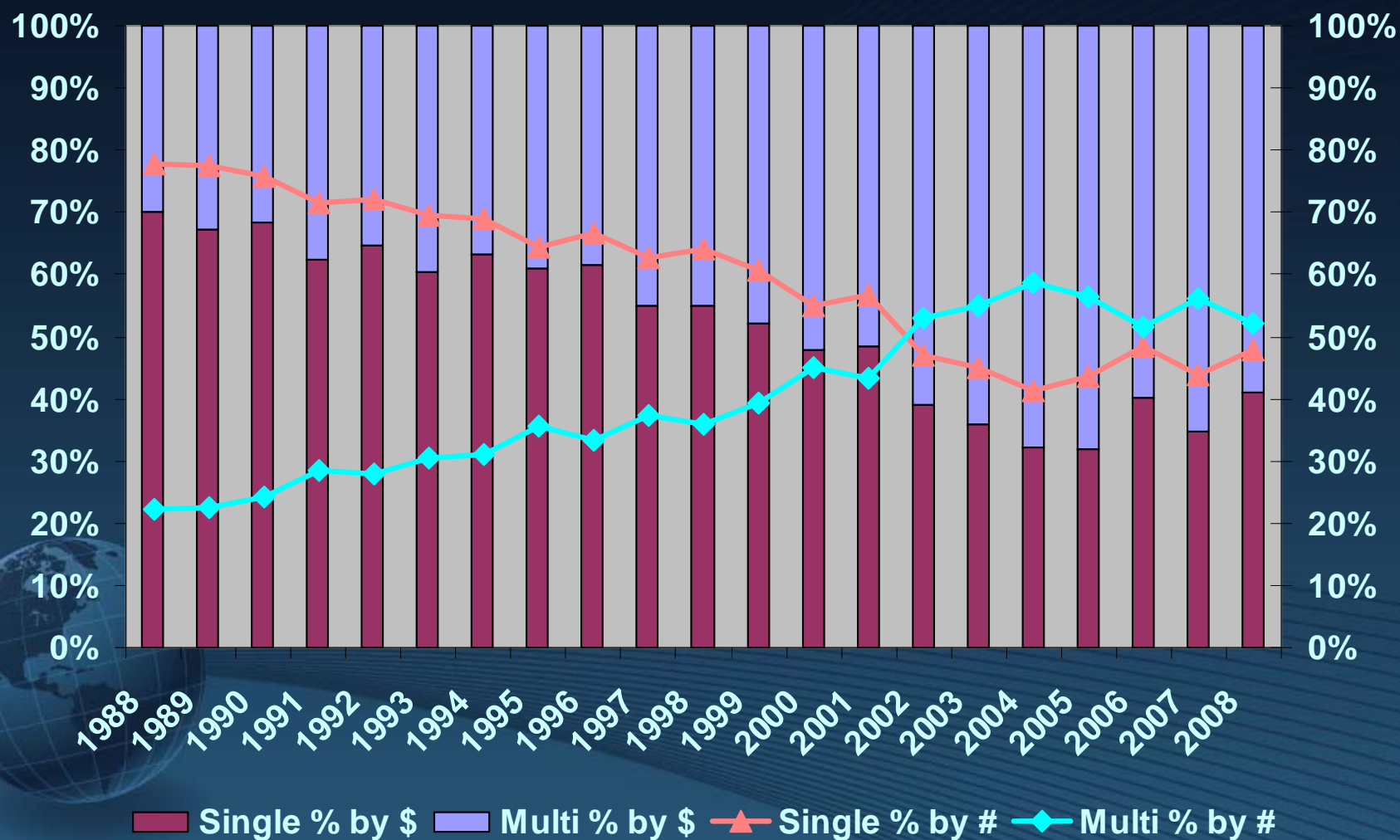



Peer Review Process

- Program director identifies reviewers
- Reviewers perform 6-9 proposal reviews
- Panelists come to NSF for 1-2 days to discuss and rank proposals
- Program director recommends proposals for funding
- Recommendation goes through the approval process
- PIs are notified (at least 70% within six months of submission window)



Merit Review Criteria

◎ Intellectual Merit

- › How **important** is the proposed activity to advancing knowledge and understanding within its own field or across different fields?
- › How **well qualified** is the proposer to conduct the project?
- › To what extent does the proposed activity suggest and explore **creative and original** concepts?
- › How **well conceived and organized** is the proposed activity?
- › Is there sufficient access to **resources**?
- › Is it **transformative**?





Transformative Research

- › *Research driven by ideas that **have the potential to radically change** our understanding of an important existing scientific or engineering concept or leading to the creation of a new paradigm or field of science or engineering. Such research also is characterized by its challenge to current understanding or its pathway to new frontiers.*

NSB Report, March 2007



Merit Review Criteria

◎ Broader Impacts

- › Advancement of discovery and understanding while promoting **teaching**
- › Participation of **underrepresented groups**
- › Enhancement of the **infrastructure**
- › **Dissemination** of results
- › Benefits to **society**



A Few Proposal Hints

- Make sure proposal is **well written** and easy to follow
- Write as much to non-expert as expert (**balance**)
- Follow the rules. **Compliance checking** is becoming stricter
- Research should be **transformative** and exciting – not incremental



Operations Research Program

Mission

To support fundamental research leading to the creation of innovative mathematical models, analysis, and algorithms for optimal or near optimal decision-making in the design and operation of manufacturing, service and other complex systems

A stylized globe showing the Americas, rendered in a dark blue color with a grid of latitude and longitude lines, positioned to the left of the text.

Traditional Areas of Research

Discrete and Continuous Optimization, Stochastic Modeling and Analysis



Emerging Research Thrusts

- ◎ Intelligent Transportation Systems (OR, SES, and MES Programs)
- ◎ Oracle Based Optimization Algorithms
 - > Simulation models
- ◎ Self-Optimizing Systems
 - > Observe, learn, adapt



Some Recent Grants in the Operations Research Program

- Novel Approaches to Mixed-Discrete and Nonconvex Programs: Polyhedral and Algebraic Methods
- Collaborative Research: Exploiting Cyberinfrastructure to Solve Real-Time Integer Programs
- Enhancing the Solvability of Discrete and Continuous Nonconvex Programs with Applications to Production, Design, and Operational Problems
- CAREER - Semidefinite Programming with Applications in Statistical Learning
- CAREER - Efficient Monte Carlo Methods in Engineering and Science: From Coarse Analysis to Refined Estimators
- Collaborative Research: Adaptive Search for Global Optimization
- Collaborative Research: Fictitious Play for Complex Systems Optimization



Resources

- ◉ Directorate for Engineering:
 - > Robert L. Smith, rlsmith@nsf.gov
 - > Today's Talk:
http://www-personal.umich.edu/~rlsmith/ENG_Talk.ppt
 - > <http://www.nsf.gov/eng>
- ◉ Funding Opportunities:
<http://www.nsf.gov/funding/>
- ◉ NSF Email Updates: www.nsf.gov