

## DEVELOPMENT OF A MOBILE MANIPULATOR TO REDUCE LIFTING ACCIDENTS

### Objective

Develop a mobile manipulator that one person can use to lift and maneuver 50- to 600-pound loads. It can be used in maintenance shops and mines to reduce lifting accidents (Figure 1 and 2).

### Background

Lifting heavy items is one of the leading causes of injury in the workplace. Mine Safety and Health Administration statistics showed that, in 2004, back injuries accounted for over 20% of all injuries (1,699 cases) and resulted in 110,000 lost days of work. Forty-one percent of those injuries resulted from materials-handling or maintenance activities.<sup>1</sup> In addition to back injuries, lifting injuries include hernias, ruptures, sprains, and strains resulting from losing control of the item being lifted. Factors associated with accidents are weight of the item being lifted, awkward postures, inadequate handholds, and the working environment itself.

High accident rates were noted when lifting items that ranged from 50 to 600 pounds, particularly in tight working quarters where maneuverability was critical. Research indicated that a mobile lifting arm would eliminate many lifting accidents in environments where other lifting devices (fork lifts, overhead cranes, mobile A-frames) would not be practical.

NIOSH has built a first-generation mobile manipulator unit designed to be used on hard, level floors such as in a shop. The complexity of motion, number of moving parts, compact design, and design constraints of the manipulator required advanced computer-aided design work (Figure 3). As a result of the design work, thirty-eight claims are included in the patent applications. NIOSH will be conducting field trials and working with manufacturers to put the manipulator into industrial use.

### Operating the Mobile Manipulator

The mobile manipulator is a self-propelled, battery-powered lifting arm mounted on a central turret that allows full rotation.

<sup>1</sup>Mine Safety and Health Administration. (2004) *Mining Industry Accident, Injuries, Employment, and Production Statistics*. Available from <http://www.msha.gov/ACCINJ/accinj.htm>



Figure 1.—Manipulator in operation.

To operate, a worker trams the unit into position for the lifting task and deploys stab-jacks for leveling and stabilizing. The linkage system is designed to allow the operator to guide heavy loads precisely; for example, sliding a 200-pound gear assembly onto a shaft where alignment and damage to equipment are critical considerations. Although the operator needs only 10 pounds of pressure to lift the load, the momentum of moving the load can create a need for braking, and so the operator has hand brakes to stop arm and turret movement immediately. The ease of tramping and steering, along with the small size of the manipulator, allows operators to stow the unit conveniently close by without interfering with ongoing operations.

### For More Information

To obtain more technical information about the mobile manipulator or inquire about becoming involved in the manufacturing phase of development, contact Eric Zahl or Curtis Clark at (509) 354-8000 or fax to (509) 354-8099; e-mail [EZahl@cdc.gov](mailto:EZahl@cdc.gov) or [CCClark@cdc.gov](mailto:CCClark@cdc.gov); or mail to Eric Zahl, NIOSH Spokane Research Laboratory, 315 E. Montgomery Ave., Spokane, WA 99207.

## Design Features

- Mobile with multiple speeds for tramping and turning
- Compact and easy to stow or transport underground
- Full range of motion for ease of maneuvering objects
- Lifting pressure felt by operator limited to 10 pounds
- Operator positioned near lifting to control movement
- Leveling and stability provided by jacks
- Gripping attachments for specific tasks
- Power choices: on-board battery, compressed air, or 110-V cords
- Braking on lifting arm for load control



Figure 2.—Manipulator shown loaded with stabilizers activated.

Specifications	
<b>Vehicle</b>	
Weight	2500 lb
Length	64 in
Width-tram	32 in
Width-oper	44 in
Height-tram	77 in
Height-oper	97 in
Speed slow	1/2 mph
Speed fast	2 mph
Drive system	Hydraulic
Gradability	15%
<b>Manipulator</b>	
Lifting cap-hook	600 lb
Arm vertical reach	41 in
Arm horizontal reach	50 in
Arm turret rotation	360 <sup>N</sup>
Op. sys	Pneumatic
Op pressure	90 psi

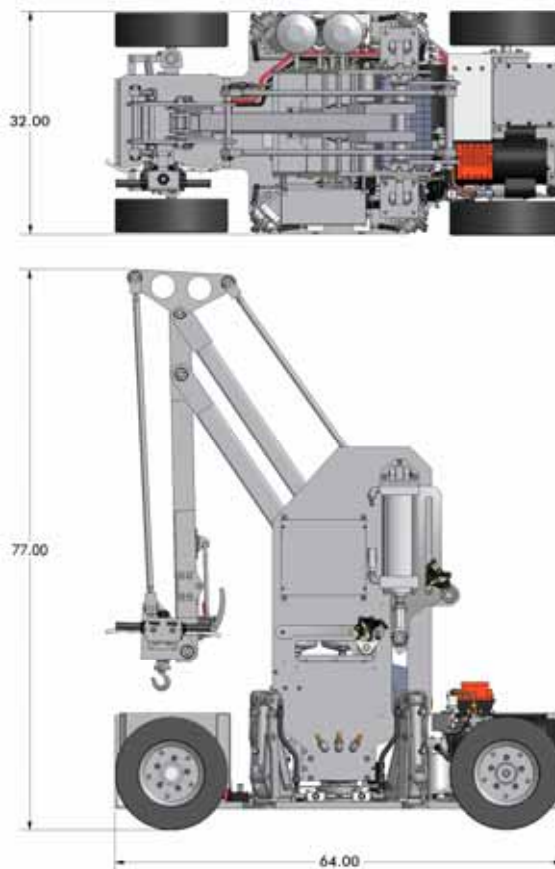

Figure 3.—Design specifications.

To receive other information about occupational safety and health topics, call 1-800-35-NIOSH (1-800-356-4674), or visit the NIOSH Website at [www.cdc.gov/niosh](http://www.cdc.gov/niosh)

Mention of any company name or product does not constitute endorsement by the National Institute for Occupational Safety and Health.