

VOLUME 2

***Well-to-Wheel Energy Use and
Greenhouse Gas Emissions of
Advanced Fuel/Vehicle Systems
– North American Analysis –***

***General Motors
Corporation***

***Argonne National
Laboratory***

BP

ExxonMobil

and

Shell

June 2001

VOLUME 2

**General Motors
Corporation**

**Argonne National
Laboratory**

BP

ExxonMobil

and

Shell

***Well-to-Wheel Energy Use and
Greenhouse Gas Emissions of
Advanced Fuel/Vehicle Systems
– North American Analysis –***

June 2001

DISCLAIMER

Because many factors critical to the potential commercial viability of the technologies addressed in this study lie beyond the scope of the study's analysis, this report cannot provide the basis for dependable predictions regarding marketplace feasibility or timetables for implementation or commercialization of the technologies examined herein.

Preface

Project Description and Acknowledgments

Need for the Study

There are differing yet strongly held views among the various “stakeholders” in the advanced fuel/propulsion system debate. In order for the introduction of advanced technology vehicles and their associated fuels to be successful, it seems clear that four important stakeholders must view their introduction as a “win”:

- Society,
- Automobile manufacturers and their key suppliers,
- Fuel providers and their key suppliers, and
- Auto and energy company customers.

If all four of these stakeholders, from their own perspectives, are not positive regarding the need for and value of these advanced fuels/vehicles, the vehicle introductions will fail.

This study was conducted to help inform public and private decision makers regarding the impact of the introduction of such advanced fuel/propulsion system pathways from a societal point of view. The study estimates two key performance criteria of advanced fuel/propulsion systems on a total system basis, that is, “well” (production source of energy) to “wheel” (vehicle). These criteria are energy use and greenhouse gas emissions per unit of distance traveled.

The study focuses on the U.S. light-duty vehicle market in 2005 and beyond, when it is expected that advanced fuels and propulsion systems could begin to be incorporated in a significant percentage of new vehicles. Given the current consumer demand for light trucks, the benchmark vehicle considered in this study is the Chevrolet Silverado full-size pickup.

How This Study Differs from Other Well-to-Wheel Analyses

This study differs from prior well-to-wheel analyses in a number of important ways:

1. The study considers fuels and vehicles that might, albeit with technology breakthroughs, be commercialized in large volume and at reasonable prices. In general, fuels and propulsion systems that appear to be commercially viable only in niche markets are not considered.
2. The study provides best estimates and associated confidence bounds of the criteria mentioned above to allow the reader to assess differences between fuel/vehicle propulsion systems on a more statistically sound basis. This approach provides not only the best estimate, but also a measure of the uncertainty around the best estimate.

3. The study incorporates the results of a proprietary vehicle model created and used by General Motors.
4. The well-to-wheel analysis involved participation by the three largest privately owned fuel providers: BP, ExxonMobil, and Shell.
5. The 15 vehicles considered in the study include conventional and hybrid electric vehicles with both spark-ignition and compression-ignition engines, as well as hybridized and non-hybridized fuel cell vehicles with and without onboard fuel processors. All 15 vehicles were configured to meet the same performance requirements.
6. The 13 fuels considered in detail (selected from 75 different fuel pathways) include low-sulfur gasoline, low-sulfur diesel, crude oil-based naphtha, Fischer-Tropsch naphtha, liquid/compressed gaseous hydrogen based on five different pathways, compressed natural gas, methanol, and neat and blended (E85) ethanol. These 13 fuels, taken together with the 15 vehicles mentioned above, yielded the 27 fuel pathways analyzed in this study.

Format

The study was conducted and is presented in three parts:

- Well-to-Tank (WTT): consideration of the fuel from resource recovery to delivery to the vehicle tank,
- Tank-to-Wheel (TTW): consideration of the vehicle from tank to the wheel, and
- Well-to-Wheel (WTW): integration of the WTT and TTW components.

The following figure illustrates the stages involved in a full fuel-cycle analysis. Argonne's study covers the WTT (or feedstock and fuel-related) stages (Part 1). GM evaluated the fuel economy and emissions of various vehicle technologies using different fuels (TTW analysis) (Part 2). In a separate effort, Argonne's WTT results were combined with GM's TTW results to produce WTW results (Part 3).

Volume 1 of this report series contains the Executive Summary Report, Volume 2 the full three-part study report, and Volume 3 the complete WTT report submitted to GM by Argonne (including detailed assumptions and data).

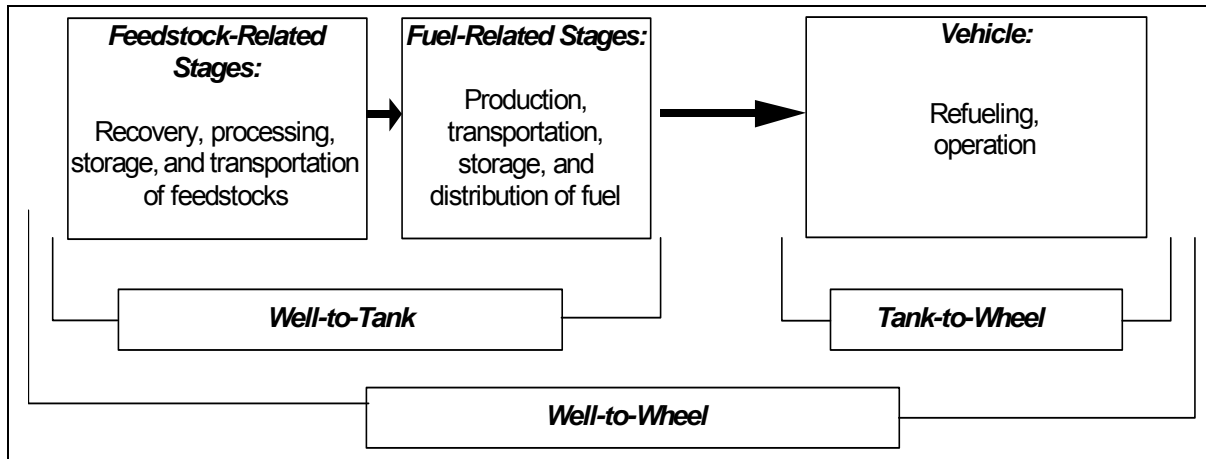

Full Fuel-Cycle Analysis

Study Organization

Mr. Greg Ruselowski of General Motors' Global Alternative Propulsion Center (GAPC) initiated the study. The study team was organized as follows:

Program Management

Program Manager: Dr. James P. Wallace III, Wallace & Associates

Assistant Program Manager: Raj Choudhury, GM GAPC

Part 1: Well-to-Tank Analysis

Project Leader and Principal Researcher: Dr. Michael Wang, Argonne National Laboratory

Project Team: Dr. Dongquan He, Argonne National Laboratory

GM Project Manager: Dr. Anthony Finizza, AJF Consulting

Project Reviewers:

BP: Andrew Armstrong and Dr. James Simnick

ExxonMobil: Gilbert Jersey and Dr. John Robbins

Shell: Jean Cadu

GM: Norman Brinkman

Argonne National Laboratory: Dr. Dan Santini

Part 2: Tank-to-Wheel Analysis

Project Leader and Principal Researcher: Trudy Weber, GM R&D and Planning Center

Team: Dr. Moshe Miller, Advanced Development Corporation; Dr. David Masten, GAPC; and Gerald Skellenger, GM R&D and Planning Center

Project Reviewers:

GM R&D and Planning Center: Dr. Hazem Ezzat, Dr. Roger Krieger, and Norman Brinkman

GM GAPC: Gary Stottler, Dr. Udo Winter, and Mattias Bork

GM Powertrain: Dr. Fritz Indra, Tim Peterson, Arjun Tuteja, Dr. Ko-Jen Wu, and Tony Zarger
GM Truck: Dr. Tanvir Ahmad
GM ATV: Dr. Peter Savagian and John Hepke

Part 3A: Well-to-Tank Pathways Down Select

Project Leader: Dr. Anthony Finizza, AJF Consulting

Project Reviewers:

BP: Andrew Armstrong and Dr. James Simnick
ExxonMobil: Gilbert Jersey and Dr. John Robbins
Shell: Jean Cadu
Argonne: Dr. Michael Wang and Dr. Dan Santini

Part 3B: Well-to-Wheel Integration

Project Co-Leaders: Dr. Anthony Finizza, AJF Consulting, and Dr. James P. Wallace III, Wallace & Associates

Project Reviewers:

BP: Andrew Armstrong and Dr. James Simnick
ExxonMobil: Gilbert Jersey and Dr. John Robbins
Shell: Jean Cadu
GM: Norman Brinkman and Raj Choudhury
Argonne: Dr. Michael Wang and Dr. Dan Santini

Acknowledgments

In addition to the participants cited above, the Program Team wishes to acknowledge the support of the following people: Tom Bond, Manager of Global Fuels Technology, BP; Tim Ford, Vice President Fuels, Shell International Petroleum Co. Ltd.; Dr. Eldon Priestley, Manager, Corporate Strategic Research, ExxonMobil Research and Engineering; Dr. James Katzer, Strategic Planning and Programs Manager, ExxonMobil Research and Engineering; Dr. Byron McCormick, Director of GM GAPC; Dr. James A. Spearot, Director, Chemical and Environmental Sciences Lab, GM R&D and Planning Center; Dr. Larry Johnson, Director of Argonne National Laboratory's Transportation Technology R&D Center; and Robert Larsen, Director of Argonne National Laboratory's Center for Transportation Research, all of whom provided invaluable support in the ongoing review process for this report.

The study participants would like to thank Tien Nguyen, Dr. Phillip Patterson, and David Rodgers of the U.S. Department of Energy's Office of Transportation Technologies; without their support of previous versions of the GREET model, this study would not have been possible. We would also like to acknowledge the editorial support of Mary Fitzpatrick of Argonne.

Additional acknowledgments are made in each part of the full report.

Responsibility

Argonne assumes responsibility for the accuracy of Part 1 but acknowledges that this accuracy was enhanced through significant contributions and thorough review by the study team, especially participants from the energy companies cited.

GM is exclusively responsible for the quantification of comparative vehicle technologies considered in Part 2.

Part 3A sought to further down-select the 75 fuel pathways examined in Part 1 into fuels that appear to be potentially feasible at high volumes and reasonable prices. The three energy companies provided key input for the conclusions reached in this section.

The GM Well-to-Wheel Integration Model used for Part 3B was developed and simulated by AJF Consultants and Wallace & Associates and is the property of GM. GM, Argonne, and the energy companies have reviewed the model and its simulation results and find them consistent and rational, given the model input.

Next Steps

A follow-up study to estimate criteria pollutants for the United States is in the planning stage. In addition, efforts are underway to provide a European counterpart to this study.

Contents

Preface.....	iii
Notation.....	xv

Part 1: Well-to-Tank Energy Use and Greenhouse Gas Emissions of Transportation Fuels

1.1 Introduction.....	1-1
1.2 Methodology.....	1-1
1.2.1 Fuels and Production Pathways.....	1-2
1.2.1.1 Petroleum-Based Fuels.....	1-2
1.2.1.2 Natural-Gas-Based Fuels.....	1-3
1.2.1.3 Bio-Ethanol Options.....	1-8
1.2.1.4 Electricity Generation.....	1-8
1.2.1.5 Hydrogen Production via Electrolysis.....	1-9
1.2.2 Probability Distribution Functions for Key Parameters.....	1-9
1.2.3 Transportation of Feedstocks and Fuels.....	1-9
1.3 Results.....	1-13
1.3.1 Total Energy Use.....	1-16
1.3.2 Fossil Energy Use.....	1-16
1.3.3 Petroleum Use.....	1-17
1.3.4 Greenhouse Gas Emissions.....	1-17
1.4 Conclusions.....	1-22
1.5 Acknowledgments.....	1-22

Figures

1.1 Well-to-Tank Stages Covered in Argonne’s Study.....	1-1
1.2 Pathways of Petroleum-Based Fuels.....	1-3
1.3 Pathways of Compressed Natural Gas Production.....	1-4
1.4 Pathways of Methanol Production.....	1-5
1.5 Pathways of Fischer-Tropsch Diesel and Naphtha Production.....	1-5
1.6 Pathways of Gaseous Hydrogen Production in Central Plants.....	1-6

Figures (Cont.)

1.7	Pathways of Gaseous Hydrogen Production at Refueling Stations.....	1-6
1.8	Pathways of Liquid Hydrogen Production in Central Plants	1-7
1.9	Pathways of Liquid Hydrogen Production at Refueling Stations	1-7
1.10	Pathways of Ethanol Production	1-8
1.11	Pathways of Electricity Generation.....	1-10
1.12	Pathways of Hydrogen Production via Electrolysis of Water at Refueling Stations	1-10
1.13	Simulation of Transportation of Energy Feedstocks and Fuels	1-12
1.14	WTT Total Energy Use.....	1-18
1.15	WTT Fossil Energy Use.....	1-19
1.16	WTT Petroleum Use.....	1-20
1.17	WTT GHG Emissions	1-21

Tables

1.1	Five Gasoline Options Included in This Study	1-3
1.2	Three Electricity Generation Mixes Analyzed.....	1-9
1.3	Parametric Probability Distribution Values for Key WTT Parameters.....	1-11
1.4	Energy Efficiencies for Feedstock and Fuel Transportation Calculated from GREET Outputs	1-13
1.5	Fuel Pathway Options Analyzed in Argonne’s WTT Study and Selected for Presentation in This Report	1-14

Part 2: Tank-to-Wheel Energy Utilization for a North American Vehicle

2.1	Introduction	2-1
2.2	Methodology	2-1
2.2.1	Vehicle Architectures	2-4
2.2.2	Vehicle Criteria	2-8
2.2.2.1	Performance Targets	2-8
2.2.2.2	Emissions Targets	2-8
2.2.2.3	Vehicle Simulation Model Input Data	2-9
2.3	Results	2-10
2.4	Conclusions	2-11
2.5	Acknowledgments	2-12
2.6	References	2-12

Figures

2.1	Energy Use in a Pickup Truck.....	2-2
2.2	HPSP Methodology.....	2-2
2.3	Sample Energy Use Diagram Provided by HPSP	2-3
2.4	Conventional Powertrain.....	2-5
2.5	Parallel Hybrid (Input Power Assist).....	2-5
2.6	Fuel Processor Fuel Cell Vehicle System	2-6
2.7	Fuel Processor Fuel Cell HEV System	2-6
2.8	Direct Fuel Cell Vehicle System.....	2-7
2.9	Direct Fuel Cell HEV System	2-7
2.10	Performance Targets	2-9

Tables

2.1	Fuel Economy (Gasoline Equivalent) and Performance Predictions	2-10
2.2	Overview of Vehicle Configurations	2-11

Part 3: Well-to-Wheel Fuel/Vehicle Pathway Integration

3.1	Introduction	3-1
3.2	Methodology	3-1
3.2.1	Part A: Selection of Well-to-Tank Pathways	3-1
3.2.1.1	Resource Availability	3-1
3.2.1.2	Energy Efficiency	3-6
3.2.2	Part B: Well-to-Wheel Integration	3-8
3.2.2.1	Well-to-Tank (Part 1)	3-8
3.2.2.2	Tank-to-Wheel (Part 2)	3-8
3.2.2.3	Well-to-Wheel (Part 3)	3-10
3.3	Results	3-10
3.3.1	Conventional and Hybrid Fuel/Vehicle Pathways	3-11
3.3.2	Fuel/Hybrid and Non-Hybrid FCV Pathways	3-13
3.4	Conclusions	3-18
3.4.1	Energy Use	3-18
3.4.2	Greenhouse Gas Emissions	3-18
3.4.3	Integrated Energy Use/GHG Emissions Results	3-20
3.5	References	3-21

Figures

3.1	Potential Natural Gas Resources	3-5
3.2	Potential Oil Resources	3-5
3.3	Well-to-Wheel Integration Process	3-8
3.4	WTW Total System Energy Use: Conventional and Hybrid Fuel/Vehicle Pathways (SI and CIDI)	3-11
3.5	Percent Energy Loss, WTT vs. TTW: Conventional and Hybrid Fuel/Vehicle Pathways (SI and CIDI)	3-12
3.6	WTW GHG Emissions: Conventional and Hybrid Fuel/Vehicle Pathways (SI and CIDI)	3-13
3.7	WTW Total System Energy Use: Hybrid Fuel/FCV Pathways	3-15

Figures (Cont.)

3.8	Percent Energy Loss, WTT vs. TTW: Hybrid Fuel/FCV Pathways	3-15
3.9	WTW GHG Emissions: Hybrid Fuel/FCV Pathways	3-16
3.10	WTW Total System Energy Use: Non-Hybrid Fuel/FCV Pathways	3-17
3.11	Percent Energy Loss, WTT vs. TTW: Non-Hybrid Fuel/FCV Pathways	3-17
3.12	WTW GHG Emissions: Non-Hybrid Fuel/FCV Pathways	3-18
3.13	WTW Total System Energy Use: “Selected” Fuel/Vehicle Pathways	3-19
3.14	Percent Energy Loss, WTT vs. TTW: “Selected” Fuel/Vehicle Pathways	3-19
3.15	WTW GHG Emissions: “Selected” Fuel/Vehicle Pathways	3-20

Tables

3.1	Comparison of Studies of the U.S. Natural Gas Market	3-2
3.2	Incremental Increase in U.S. Natural Gas Demand in 2010 Relative to 1998 Base Year	3-2
3.3	EIA Baseline Forecast of the U.S. Transportation Market	3-3
3.4	Natural Gas Resource Base	3-4
3.5	Comparison of Selected Pathways	3-7
3.6	Summary of Pathways Selected for Well-to-Wheel Integration Analysis	3-7
3.7	Fuel/Vehicle Pathways Analyzed	3-10
3.8	Total WTW System Efficiency Improvements from Hybridization	3-12
3.9	Renewable Share of WTT Total Energy Use	3-12
3.10	Total System Efficiency Improvements from Hybridization of FCVs	3-14

Appendixes to Part 3

Appendix 3A:	CO ₂ Content of Fuels	3-23
Appendix 3B:	Energy Loss Split Calculation	3-25
Appendix 3C:	Data Used to Prepare Figures 3.4 through 3.15	3-29

Notation

Acronyms and Abbreviations

ANL	Argonne National Laboratory
BSFC	brake-specific fuel consumption
CARFG2	California Phase 2 reformulated gasoline
CARFG3	California Phase 3 reformulated gasoline
CC	combined-cycle
CG	conventional gasoline
CH ₄	methane
CIDI	compression ignition direct injection
CNG	compressed natural gas
CO	carbon monoxide
CO ₂	carbon dioxide
CS	charge sustaining
CTR	Center for Transportation Research (Argonne National Laboratory)
CVT	continuously variable transmission
DOE	U.S. Department of Energy
E&P	exploration and production
E85	a mixture of 85% ethanol and 15% gasoline (by volume)
EIA	Energy Information Administration
EPA	U.S. Environmental Protection Agency
EtOH	ethanol
FC	fuel cell
FCV	fuel cell vehicle
FG	flared gas
FP	fuel processor
FRFG2	Federal Phase 2 reformulated gasoline
FT	Fischer-Tropsch
FTD	Fischer-Tropsch diesel
GAPC	Global Alternative Propulsion Center (General Motors Corporation)
GASO	gasoline
G.H ₂	gaseous hydrogen
GHG	greenhouse gas
GM	General Motors Corporation
REET	Greenhouse gases, Regulated Emissions, and Energy use in Transportation
GRI	Gas Research Institute
GTI	Gas Technology Institute
GWP	global warming potential
H ₂	hydrogen
HE100	herbaceous E100
HE85	herbaceous E85
HEV	hybrid electric vehicle
HPSP	Hybrid Powertrain Simulation Program

ICE	internal combustion engine
L.H ₂	liquid hydrogen
LNG	liquefied natural gas
LPG	liquefied petroleum gas
M85	a mixture of 85% methanol and 15% gasoline (by volume)
MeOH	methanol
MTBE	methyl tertiary butyl ether
N	nitrogen
N ₂ O	nitrous oxide
NA	North American
NAP	naphtha
NG	natural gas
NGL	natural gas liquid
NiMH	nickel metal hydride
NNA	non-North-American
NO _x	nitrogen oxides
NPC	National Petroleum Council
PM ₁₀	particulate matter with diameter of 10 μm or less
PNGV	Partnership for a New Generation of Vehicles
psi	pounds per square inch
R&D	research and development
RVP	Reid vapor pressure
SAE	Society of Automotive Engineers
SI	spark ignition
SO _x	sulfur oxides
SULEV	Super Ultra-Low Emissions Vehicle
T&S	transportation and storage
TTW	tank-to-wheel
USDA	U.S. Department of Agriculture
USGS	U.S. Geological Survey
VOC	volatile organic compound
WTT	well-to-tank
WTW	well-to-wheel
ZEV	Zero Emissions Vehicle

Units of Measure

Btu	British thermal unit(s)	mmBtu	million (10 ⁶) Btu
g	gram(s)	mph	mile(s) per hour
gal	gallon(s)	ppm	part(s) per million
kWh	kilowatt hour(s)	s	second(s)
m	meter(s)	μm	micrometer(s)
mi	mile(s)		

Part 1

Well-to-Tank Energy Use and Greenhouse Gas Emissions of Transportation Fuels

Michael Wang and Dongquan He
Center for Transportation Research
Argonne National Laboratory

June 2001

1.1 Introduction

Various fuels are proposed for use in fuel cell vehicles (FCVs) and hybrid electric vehicles (HEVs). Different fuels are made by different production pathways, and consequently they result in different energy and greenhouse gas (GHG) emission impacts. To fully analyze these impacts, full fuel-cycle analyses — from energy feedstock recovery (wells) to energy delivered at vehicle wheels — are needed.

The Global Alternative Propulsion Center (GAPC) of the General Motors Corporation (GM) commissioned the Center for Transportation Research (CTR) at Argonne National Laboratory (Argonne) to conduct a study to evaluate energy and emission impacts associated with producing different transportation fuels and delivering those fuels to vehicle tanks (well-to-tank [WTT] analysis). Argonne's study is part of an overall study by General Motors to analyze well-to-wheel energy use and GHG emissions impacts of advanced fuel/vehicle systems. Three energy companies — BP, ExxonMobil, and Shell — participated in the study by providing critical input and reviewing Argonne's results. The timeframe for the WTT analysis is 2005 and beyond.

This report was originally produced as an extensive summary of a sponsor report delivered by Argonne to GM. Detailed information regarding the methodology, assumptions, results, and references for Argonne's study are provided in the sponsor report, published as Volume 3 of this report series.

1.2 Methodology

Figure 1.1 illustrates the WTT stages covered in Argonne's study. GM conducted an in-house study to evaluate the fuel economy and emissions of various vehicle technologies using different fuels (tank-to-wheel [TTW] analysis). GM then combined Argonne's WTT results and GM's TTW results to obtain well-to-wheel (WTW) results. Argonne assumes responsibility for the accuracy of WTT results but acknowledges that this accuracy was enhanced through significant contributions and thorough review by the study team, especially participants from the energy companies.

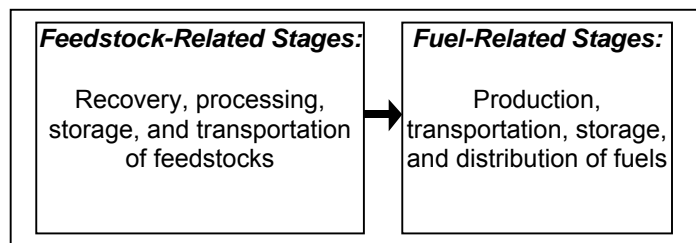

Figure 1.1 Well-to-Tank Stages Covered in Argonne's Study

To complete our WTT study, we used a model developed by Argonne to estimate WTT energy and emission impacts of alternative transportation fuels and advanced vehicle technologies. The model, called GREET (Greenhouse gases, Regulated Emissions, and Energy use in Transportation), is capable of calculating WTW energy use (in British thermal units per mile [Btu/mi]) and emissions (in grams per mile [g/mi]) for transportation fuels and vehicle technologies; for our study, we used only the WTT portion of GREET.

For energy use modeling, GREET includes total energy use (all energy sources), fossil energy use (petroleum, natural gas, and coal), and petroleum use. For emissions modeling, GREET includes three major greenhouse gases (GHGs) specified in the Kyoto protocol (carbon dioxide [CO₂]), methane [CH₄], and nitrous oxide [N₂O]) and five criteria pollutants (volatile organic compounds [VOCs], carbon monoxide [CO], nitrogen oxides [NO_x] particulate matter with diameters of 10 μm or less [PM₁₀], and sulfur oxides [SO_x]). The three GHGs are combined with their global warming potentials (GWPs) to calculate CO₂-equivalent GHG emissions. Emissions of the five criteria pollutants are further separated into total and urban emissions. Total emissions occur everywhere; urban emissions occur within urban areas. The separation is based on information regarding facility locations and is intended to provide an estimate of the exposure to air pollution caused by the criteria pollutants.

For this project, Argonne estimated total and fossil energy use, petroleum use, and CO₂-equivalent emissions of the three GHGs. Emissions of criteria pollutants were not included in this study.

For our WTT study, we employed a new version of GREET that simulates transportation of energy feedstocks and fuels by using detailed input parameters regarding transportation modes and their corresponding distances for different energy feedstocks and fuels. The new version also incorporates a Monte Carlo simulation to formally address uncertainties involved in key input parameters. The new GREET version will soon be released to the public.

We analyzed 75 fuel pathways for application to (1) vehicles with stand-alone internal combustion engines (ICEs), (2) HEVs, and (3) FCVs. The following sections describe the fuels and production pathways chosen for our study. Volume 3 of this report series, which contains Argonne's sponsor report delivered to GM, provides results for the 75 pathways analyzed and details regarding the assumptions used in our study.

1.2.1 Fuels and Production Pathways

1.2.1.1 Petroleum-Based Fuels

This study included three petroleum-based fuels: gasoline, diesel, and naphtha. For gasoline and diesel, we established cases to represent different fuel requirements. For gasoline, we included federal conventional gasoline (CG), federal Complex Model Phase 2 reformulated gasoline (FRFG2), California Phase 2 reformulated gasoline (CARFG2), California Phase 3 reformulated gasoline (CARFG3), and the gasoline requirements in the U.S. Environmental Protection Agency's (EPA's) Tier 2 vehicle emission standards. These gasoline types contain sulfur at concentrations ranging from 5 parts per million (ppm) to over 300 ppm and may contain methyl tertiary butyl ether (MTBE), ethanol (EtOH), or no oxygenates. Table 1.1 presents typical properties of the gasoline options analyzed in this study.

For on-road diesel fuels, we included two options: a current diesel and a future diesel. The current diesel has a sulfur content of 120–350 ppm. The future diesel reflects the new diesel requirement adopted recently by EPA, with a sulfur content below 15 ppm.

Table 1.1 Five Gasoline Options Included in This Study

Characteristic	Current Gasoline		Future Gasoline ^a		
	CG	FRFG2 with MTBE	RFG with MTBE	RFG with EtOH	RFG with no Oxygenate
RVP (psi, summer) ^b	8.9	6.7	6.7	6.7	6.7
Sulfur content (wt. ppm)	340	150	5-30	5-30	5-30
Benzene content (vol. %)	1.53	0.68	0.68	0.68	0.68
Aromatics content (vol. %)	32	25	25	25	25
Oxygen content (wt. %)	0.4	2.26	2.26	3.5	0

^a Future gasoline reflects CARFG3 and EPA's Tier 2 gasoline requirements.

^b RVP = Reid vapor pressure; psi = pounds per square inch.

Naphtha could be used as a fuel cell fuel. Virgin crude naphtha from petroleum refineries' distillation (without desulfurization) has a sulfur content of about 370 ppm. For fuel cell applications, we assumed that the sulfur content of crude naphtha would be reduced to about 1 ppm by means of hydrotreating or some other desulfurization measure.

Figure 1.2 shows WTT stages for the petroleum fuel pathways analyzed in this study. Crude recovery and crude refining (shaded) are the key stages for which we established probability distribution functions for their energy efficiencies in this study.

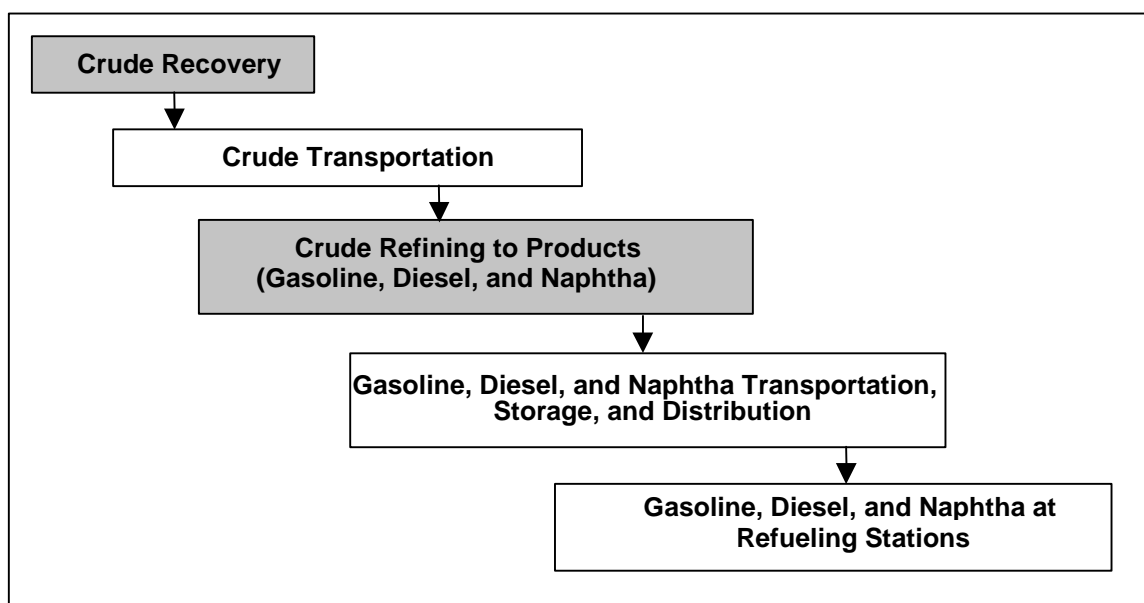

Figure 1.2 Pathways of Petroleum-Based Fuels

1.2.1.2 Natural-Gas-Based Fuels

Our study included the following fuels based on natural gas (NG): compressed natural gas (CNG), methanol (MeOH), Fischer-Tropsch diesel (FTD), Fischer-Tropsch (FT) naphtha, gaseous hydrogen (G.H₂) produced in central plants, G.H₂ produced in refueling stations, liquid hydrogen (L.H₂) produced in central plants, and L.H₂ produced in refueling stations. These fuels are produced from three NG feedstock sources: North American (NA) sources, non-North-American (NNA) sources, and NNA flared gas (FG) sources.

While liquid fuels (i.e., methanol, L.H₂, FTD, and FT naphtha) can be produced in NNA locations and transported to the United States, CNG, G.H₂, and station-produced L.H₂ must be produced in the United States. We assumed that liquefied natural gas (LNG) is produced in NNA locations and transported to the United States for use in production of these three fuels. Thus, we estimated and included energy use and emissions of LNG production and transportation for these fuel options. Figures 1.3 through 1.9 present the production pathways for each of the fuels. The stages that are shaded are the key stages for which we established probability distribution functions for their energy efficiencies.

We assumed that CNG would be stored onboard vehicles at a pressure of about 3,600 psi. We also assumed that the NG would need to be compressed from 15 psi to 4,000 psi by means of both electric and NG compressors.

Argonne assumed that G.H₂ would be stored onboard FCVs at pressures of about 5,000 psi and that G.H₂ would be compressed to 6,000 psi at refueling stations. For centrally produced G.H₂ that is to be transported via pipeline to refueling stations, we assumed that electric compressors would be used to compress G.H₂ from an initial pressure of 250 psi. For station-produced G.H₂, we assumed that both electric and NG compressors would be used to compress G.H₂ from an initial pressure of 500 psi.

For production of L.H₂ from NNA NG and FG in central plants, we assumed that L.H₂ would be produced in NNA locations and transported to the United States via ocean tankers. For production of L.H₂ at refueling stations on the other hand, we assumed that LNG would be produced from NG and FG in NNA locations and transported to U.S. LNG terminals.

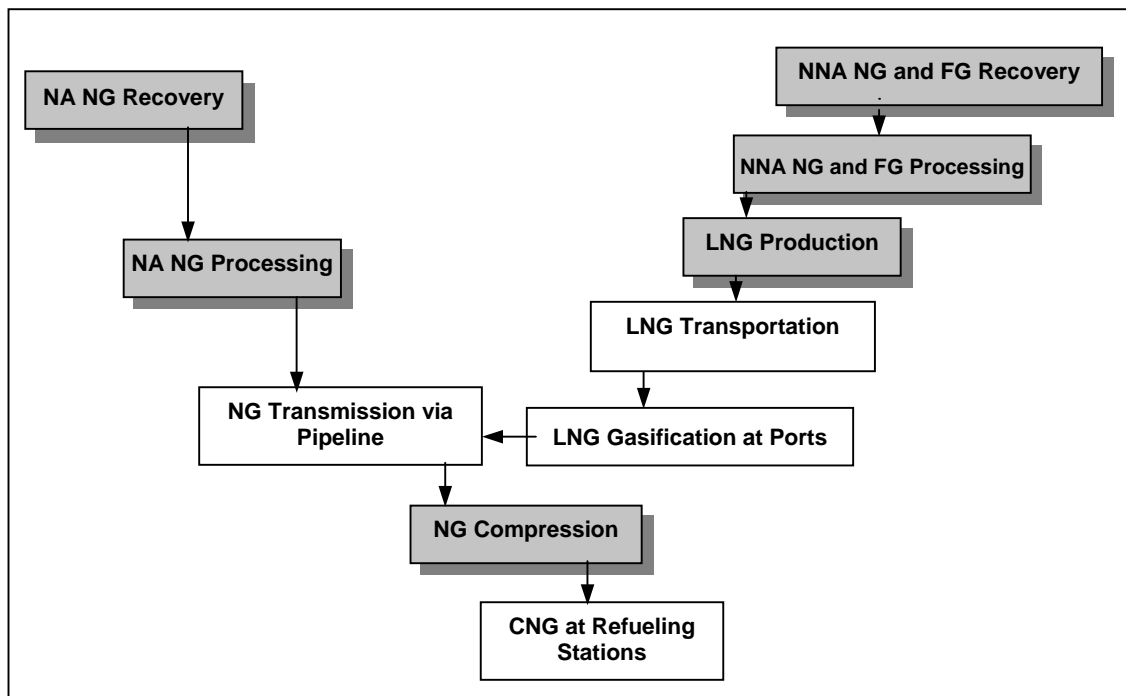

Figure 1.3 Pathways of Compressed Natural Gas Production

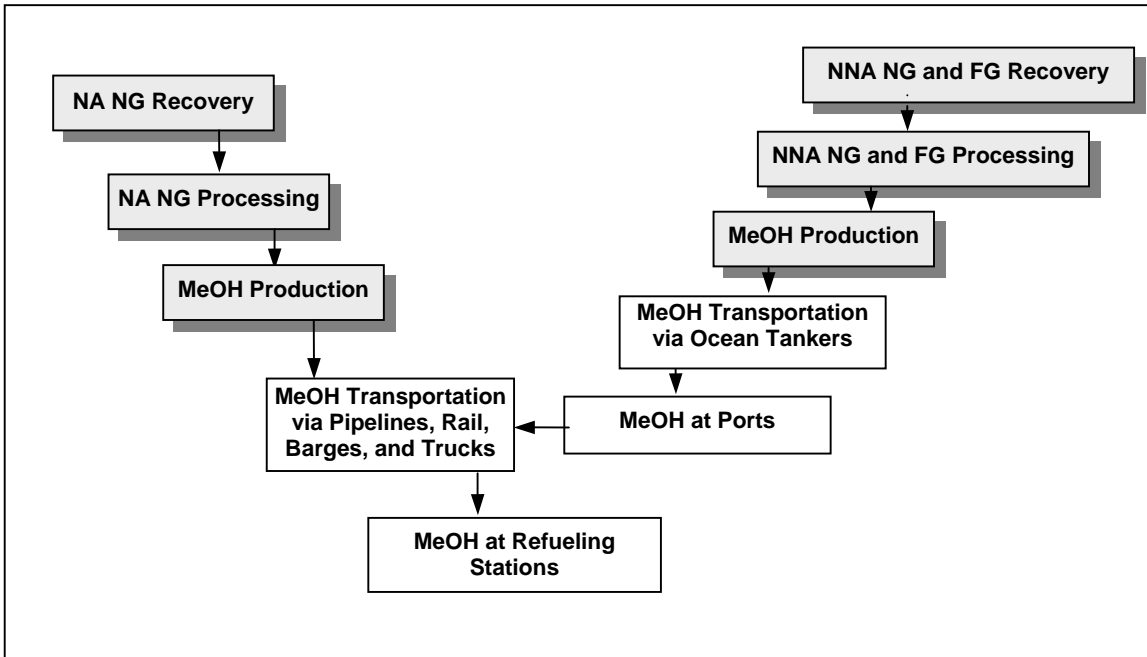

Figure 1.4 Pathways of Methanol Production

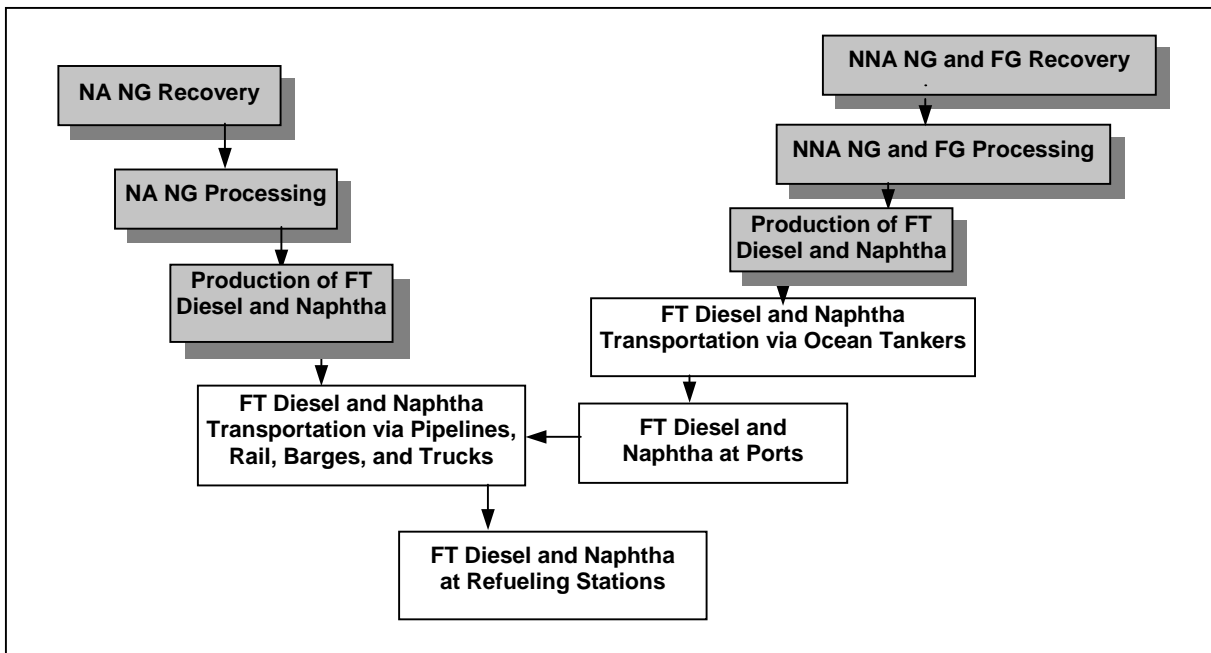

Figure 1.5 Pathways of Fischer-Tropsch Diesel and Naphtha Production

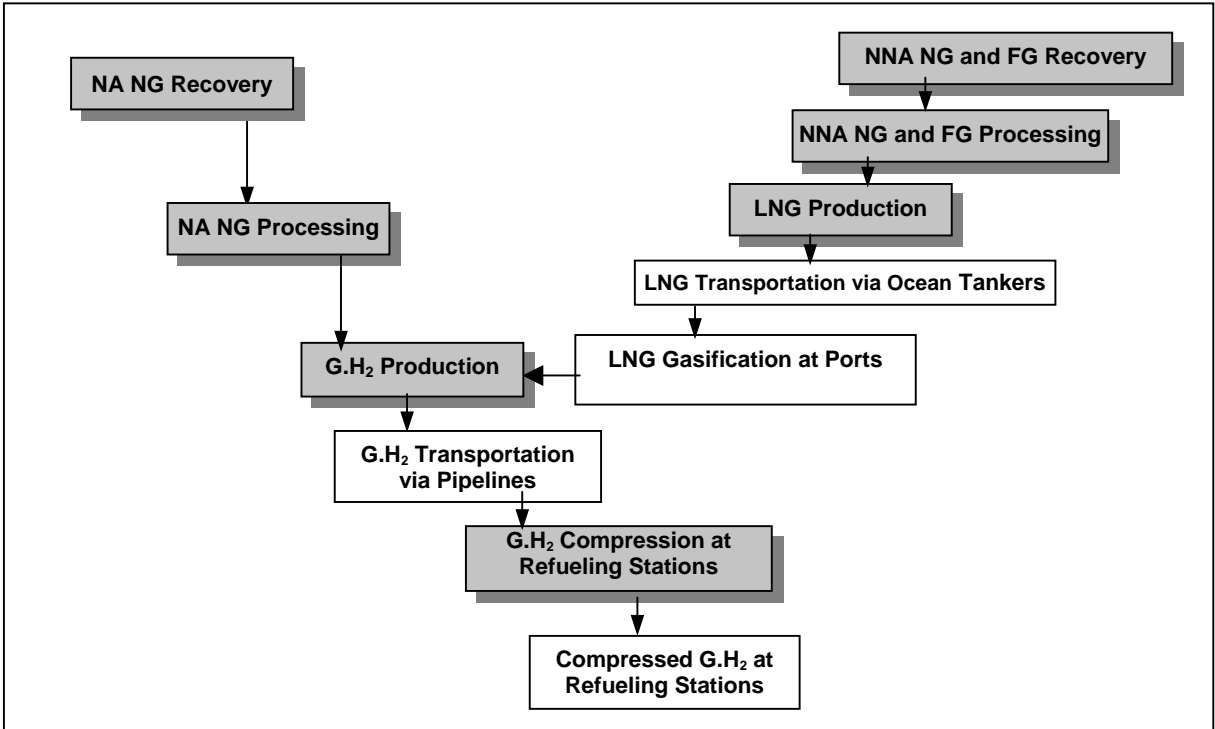

Figure 1.6 Pathways of Gaseous Hydrogen Production in Central Plants

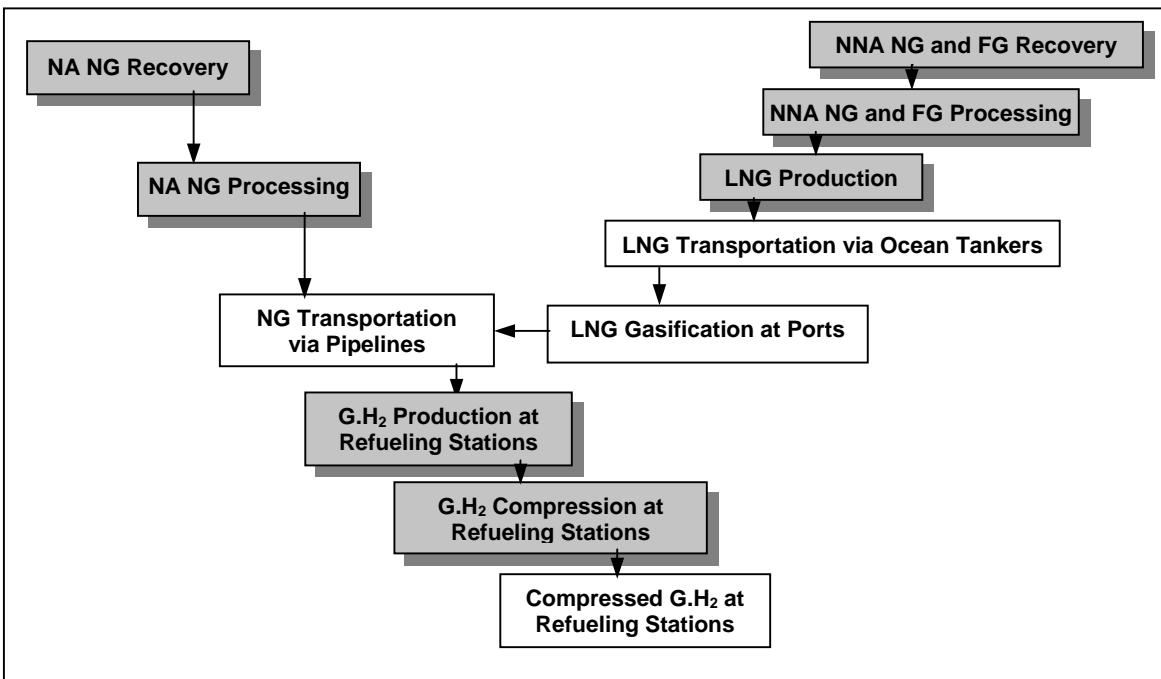

Figure 1.7 Pathways of Gaseous Hydrogen Production at Refueling Stations

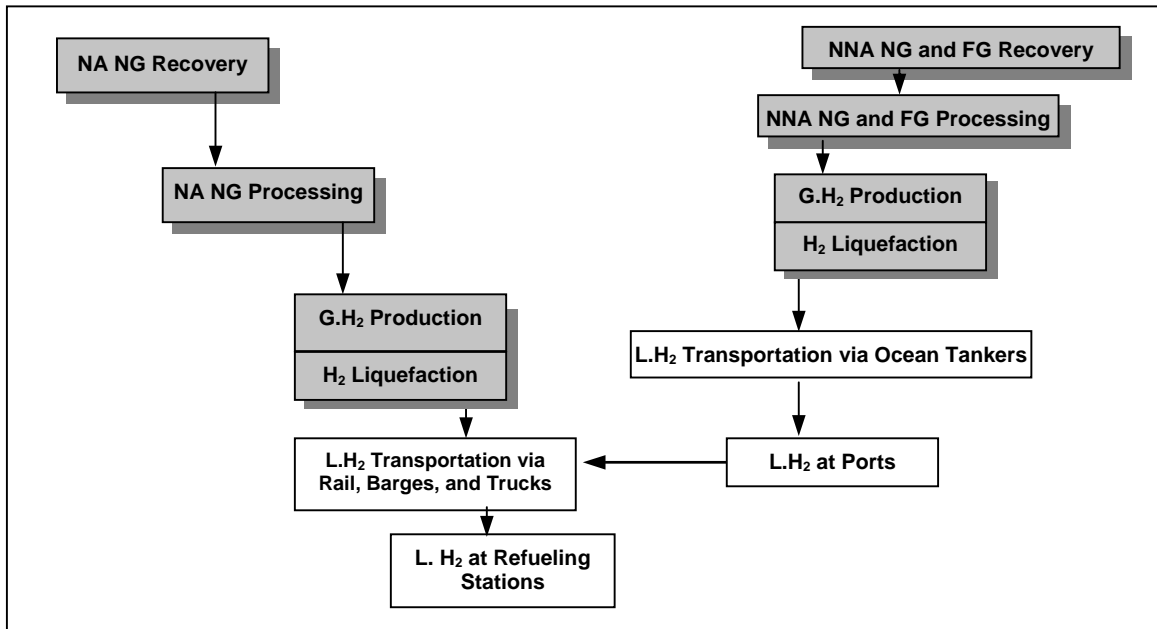

Figure 1.8 Pathways of Liquid Hydrogen Production in Central Plants

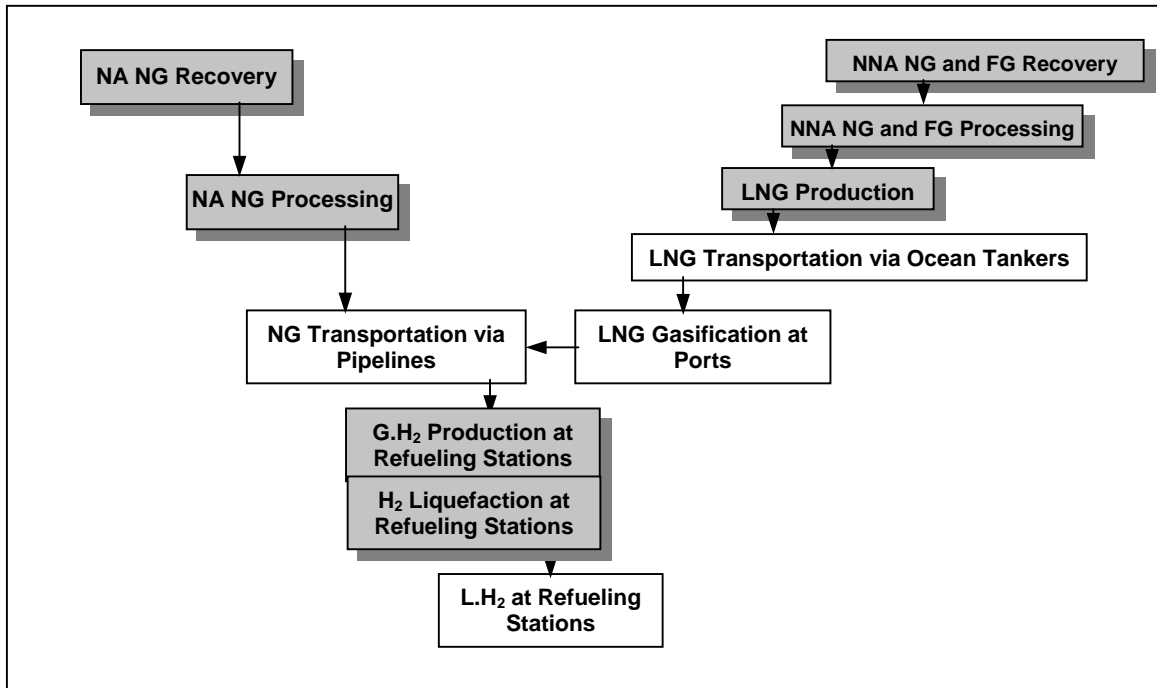

Figure 1.9 Pathways of Liquid Hydrogen Production at Refueling Stations

1.2.1.3 Bio-Ethanol Options

We included three ethanol production pathways: ethanol from corn, woody biomass (trees), and herbaceous biomass (grasses) (Figure 1.10). Corn-based ethanol can be produced in wet milling or dry milling plants; we examined both. Corn-based ethanol plants also produce other products (primarily animal feeds). We allocated energy use and emissions between ethanol and its co-products by using the market value method.

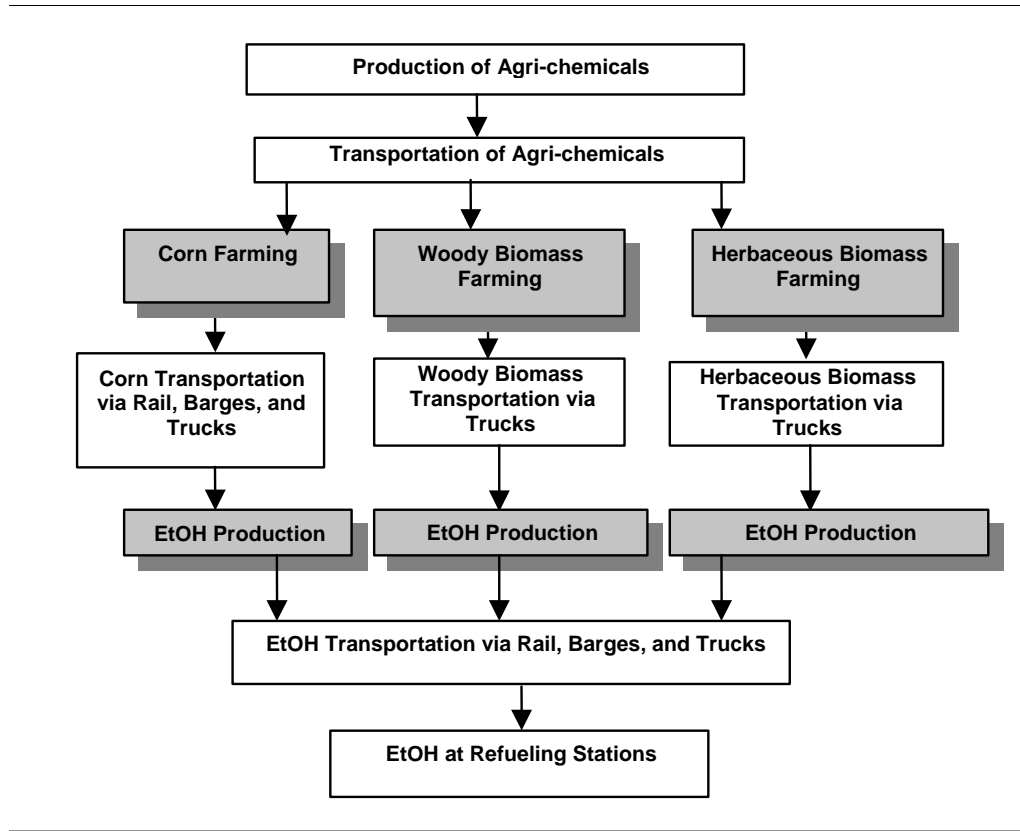

Figure 1.10 Pathways of Ethanol Production

In cellulosic (woody and herbaceous) ethanol plants, while cellulose in biomass is converted into ethanol through enzymatic processes, the lignin portion of biomass can be burned to provide needed steam. Co-generation systems can be employed to generate both steam and electricity. In this case, extra electricity can be generated for export to the electric grid. We took the generated electricity credit into account in calculating energy use and GHG emissions of cellulosic ethanol production.

1.2.1.4 Electricity Generation

Our study included three generation mixes — the U.S., the California, and the Northeast U.S. — to cover a broad range (Table 1.2). NG-fired combined-cycle (CC) turbines with high energy-conversion efficiencies have been added to U.S. electric generation capacity in the last decade. We included this technology in our analysis. We estimated energy use and GHG emissions associated with electricity generation in NG-fired CC power plants, hydroelectric plants, and nuclear plants separately.

Table 1.2 Three Electricity Generation Mixes Analyzed

Generation Mix	Power Source (%)				
	Coal	Oil	Natural Gas	Nuclear	Others ^a
U.S. Mix	54	1	15	18	12
California Mix	21	0	33	15	31
Northeast U.S. Mix	28	3	32	26	11

^a Including hydro, geothermal, solar, wind, and other electric power plants.

Emissions estimates were calculated for four types of electric power plants: oil-fired, NG-fired, coal-fired, and nuclear. Other power plants, such as hydroelectric and windmill plants, have virtually zero operation emissions. Emissions from nuclear power plants are attributable to uranium recovery, enrichment, and transportation. As Figure 1.11 shows, our estimation of emissions associated with electricity generation includes fuel production and transportation, as well as electricity generation.

1.2.1.5 Hydrogen Production via Electrolysis

Production of H₂ from electricity (by electrolysis of water at refueling stations) may represent a means to provide H₂ for FCVs. (Figure 1.12). This production option helps avoid long-distance transportation and storage of H₂. We evaluated H₂ production from electricity that is generated from hydroelectric and nuclear power as well as from the U.S. generation mix, the California generation mix, the Northeast U.S. generation mix, and NG-fired CC turbines. The first two cases represent electricity generation with zero or near-zero GHG emissions.

1.2.2 Probability Distribution Functions for Key Parameters

On the basis of our research of the efficiencies of WTT stages and input from the three energy companies (BP, ExxonMobil, and Shell) during this study, we determined probability distribution functions for key WTT stages (see Volume 3 for details). The probabilistic simulations employed in this study, a departure from the range-based simulations used in many previous Argonne studies, are intended to address uncertainties statistically. For each activity associated with the production process of each fuel, we determined the following parametric values for probability: 20%, 50%, and 80% (P20, P50, and P80). For most parameters, we assumed normal probability distributions. For some of the parameters, where a normal distribution would not describe the parameter correctly, we assumed a triangular distribution. Table 1.3 presents our estimated parametric values of distribution functions for key parameters.

1.2.3 Transportation of Feedstocks and Fuels

We employed the following five-step approach to estimate energy use and emissions for transportation of feedstocks and fuels. Figure 1.13 illustrates the method we used to simulate this portion of the fuel cycle.

- Determine transportation modes and their shares (i.e., ocean tankers, pipelines, barges, rail, and trucks) to be used to transport a given feedstock or fuel.
- Identify the types and shares of process fuels (e.g., residual oil, diesel fuels, natural gas, electricity) to be used to power each mode.

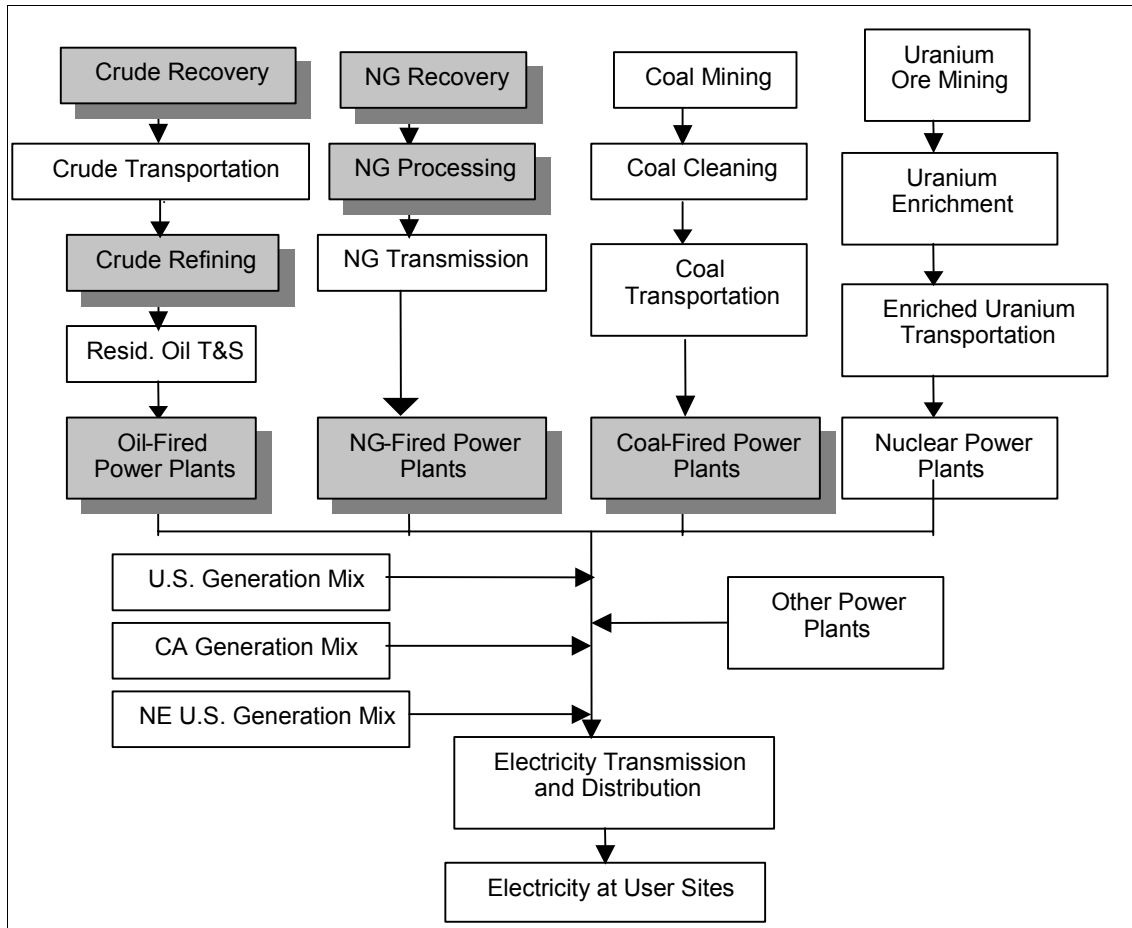

Figure 1.11 Pathways of Electricity Generation

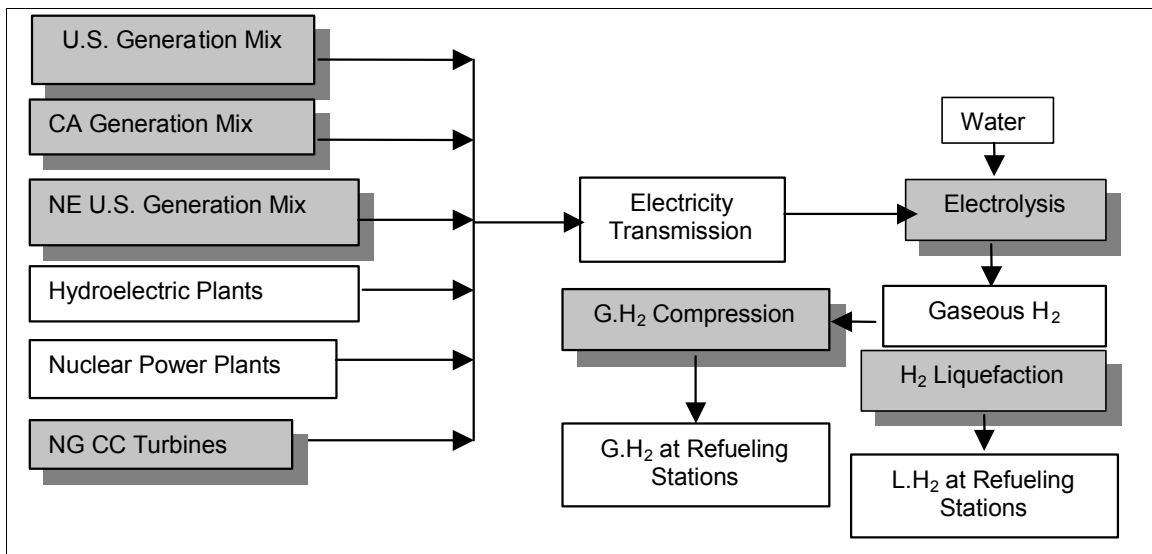

Figure 1.12 Pathways of Hydrogen Production via Electrolysis of Water at Refueling Stations

Table 1.3 Parametric Probability Distribution Values for Key WTT Parameters

Activity	Value at a Probability (%) ^a		
	P20	P50	P80
<i>Petroleum-Based Fuels</i>			
Petroleum recovery ^b	96.0	98.0	99.0
Petroleum refining: 340 ppm sulfur CG	85.0	85.5	86.0
Petroleum refining: 150 ppm sulfur RFG with MTBE: gasoline blendstock	85.0	86.0	87.0
Petroleum refining: 5–30 ppm sulfur RFG with MTBE: gasoline blendstock	84.0	85.5	87.0
Petroleum refining: 5–30 ppm sulfur RFG with EtOH: gasoline blendstock	84.0	85.5	87.0
Petroleum refining: 5–30 ppm sulfur RFG with no oxygenate	83.0	84.5	86.0
Petroleum refining: 120–350 ppm sulfur diesel	88.0	89.0	90.0
Petroleum refining: 5–30 ppm sulfur diesel	85.0	87.0	89.0
Petroleum refining: 5 ppm sulfur naphtha	89.0	91.0	93.0
<i>Natural-Gas-Based Fuels</i>			
NG recovery: NA NG, NNA NG, NNA FG	96.0	97.5	99.0
NG processing: NA NG, NNA NG, NNA FG	96.0	97.5	99.0
LNG production from NG and FG ^b	87.0	91.0	93.0
NG compression: NG compressor	92.0	93.0	94.0
NG compression: electric compressor ^b	96.0	97.0	98.0
MeOH production: with no steam production ^b	65.0	67.5	71.0
MeOH production: with steam production ^b – efficiency	62.0	64.0	66.0
MeOH production: with steam production, steam credit (Btu/mmBtu) ^b	64,520	78,130	90,910
FT diesel and naphtha production: with no steam production	61.0	63.0	65.0
FT diesel and naphtha production: with steam production	53.0	55.0	57.0
FT diesel and naphtha production: with steam production, steam credit (Btu/mmBtu)	189,000	200,000	210,500
G.H ₂ production in central plants: with no steam production	68.0	71.5	75.0
G.H ₂ production in central plants: with steam production	66.0	69.5	73.0
G.H ₂ production in central plants: with steam production, steam credit (Btu/mmBtu)	120,000	145,000	170,000
H ₂ liquefaction in central plants ^b	65.0	71.0	77.0
G.H ₂ production in stations	62.0	67.0	72.0
G.H ₂ compression for central G.H ₂ : NG compressor ^b	82.5	85.0	87.5
G.H ₂ compression for central G.H ₂ : electric compressor ^b	90.0	92.5	95.0
G.H ₂ compression for station G.H ₂ : NG compressor ^b	83.5	86.0	88.5
G.H ₂ compression for station G.H ₂ : electric compressor ^b	91.5	94.0	96.5
H ₂ liquefaction in stations	60.0	66.0	72.0
<i>Corn-to-Ethanol Pathways</i>			
Energy use for corn farming (Btu/bushel of corn) ^b	12,600	26,150	39,700
Nitrogen (N) fertilizer use in corn farms (g/bushel of corn)	370	475	580
N ₂ O emissions in corn farms: N in N ₂ O as % of N in N fertilizer ^b	1.0	1.5	2.0
Soil CO ₂ emissions in corn farms (g/bushel of corn) ^b	0	195	390
Ethanol yield, dry mill plants (gal/bushel of corn) ^b	2.5	2.65	2.8
Ethanol yield, wet mill plants (gal/bushel of corn) ^b	2.4	2.55	2.7
Energy use in dry mill plants (Btu/gal of EtOH)	36,900	39,150	41,400
Energy use in wet mill plants (Btu/gal of EtOH)	34,000	37,150	40,300
<i>Cellulosic Biomass-to-Ethanol Pathways</i>			
Energy use for tree farming (Btu/dry ton of trees)	176,080	234,770	293,460
Energy use for grass farming (Btu/dry ton of grasses)	162,920	190,080	271,540
N fertilizer use for tree farming (g/dry ton of trees)	532	709	886

Table 1.3 Parametric Probability Distribution Values for Key WTT Parameters (Cont.)

Activity	Value at a Probability (%) ^a		
	P20	P50	P80
<i>Cellulosic Biomass-to-Ethanol Pathways (Cont.)</i>			
N fertilizer use for grass farming (g/dry ton of grasses)	7,980	10,630	13,290
N ₂ O emissions in biomass farms: N in N ₂ O as % of N in N fertilizer ^b	0.8	1.15	1.5
Soil CO ₂ sequestration in tree farms (g/dry ton of trees) ^b	-225,000	-112,500	0
Soil CO ₂ sequestration in grass farms (g/dry ton of grasses) ^b	-97,000	-48,500	0
Ethanol yield, woody biomass plants (gal/dry ton of trees)	76	87	98
Ethanol yield, herbaceous biomass plants (gal/dry ton of grasses)	80	92	103
Electricity credit of woody biomass plants (kWh/gal of EtOH) ^b	-1.73	-1.15	-0.56
Electricity credit of herbaceous biomass plants (kWh/gal of EtOH) ^b	-0.865	-0.57	-0.28
<i>Electric Power Plants</i>			
Oil-fired power plants: steam boiler	32.0	35.0	38.0
NG-fired power plants: steam boiler	32.0	35.0	38.0
NG-fired power plants: CC turbines ^b	50.0	55.0	60.0
Coal-fired power plants: steam boiler	33.0	35.5	38.0
Coal-fired power plants: advanced technologies	38.0	41.5	45.0
H ₂ electrolysis efficiency	67.0	71.5	76.0

^a Values are in percent unless otherwise indicated.

^b A triangle distribution curve is assumed for these parameters. In this case, the P20 value is actually the P0 value and the P80 value is the P100 value.

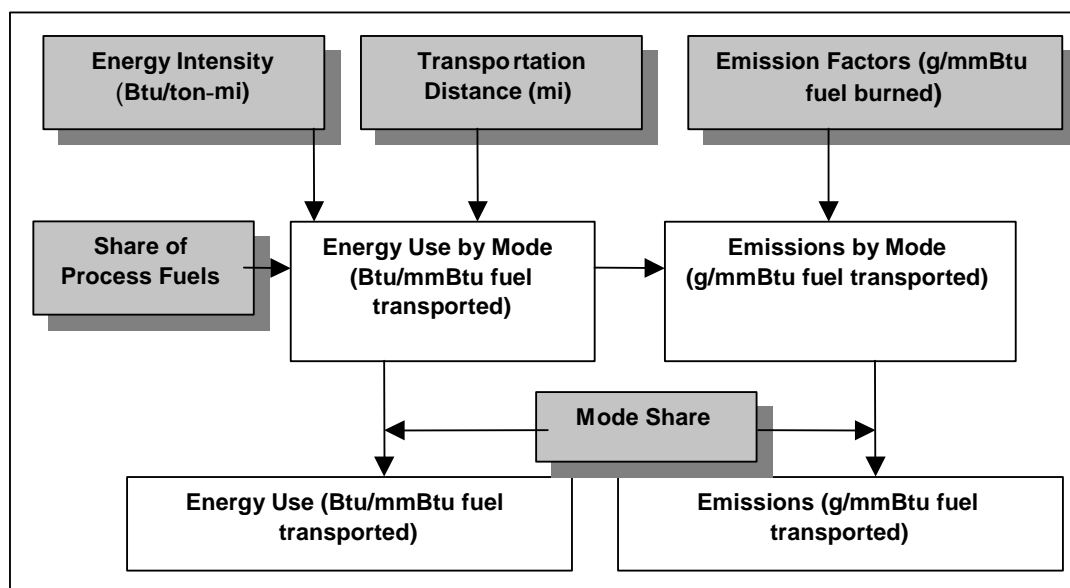

Figure 1.13 Simulation of Transportation of Energy Feedstocks and Fuels

- Estimate the distance of each transportation mode for each feedstock or fuel.
- Calculate the energy use and emissions associated with each transportation mode fueled with each process fuel.
- Add together the energy use and emissions of all transportation modes for transporting the given feedstock or fuel.

Table 1.4 presents energy efficiencies for transportation of various feedstocks and fuels. These efficiencies were output results with energy use results estimated by using the GREET model (with the detailed input parameters discussed above). For most of the feedstocks and fuels, transportation energy efficiencies are above 99%. As expected, transportation of NNA-produced fuels has lower energy efficiencies. Transportation of methanol also has low energy efficiencies because a large portion of methanol was assumed to be transported to refueling stations via trucks within the United States.

Table 1.4 Energy Efficiencies for Feedstock and Fuel Transportation
Calculated from GREET Outputs

Feedstock/Fuel	Energy Efficiency (%)
Crude oil from oil fields to U.S. refineries	99.0
Gasoline from U.S. refineries to refueling stations	99.4
Diesel from U.S. refineries to refueling stations	99.2
Petroleum naphtha from U.S. refineries to refueling stations	99.0
NG from NA NG processing plants to refueling stations	99.3
LNG from NNA plants to U.S. LNG terminals	98.5
MeOH from NA plants to refueling stations	98.0
MeOH from NNA plants to refueling stations	96.8
FT naphtha and diesel from NA plants to refueling stations	99.2
FT naphtha and diesel from NNA plants to refueling stations	98.2
Central G.H ₂ from NA H ₂ plants to refueling stations	96.3
L.H ₂ from NA H ₂ plants to refueling stations	98.9
L.H ₂ from NNA H ₂ plants to refueling stations	95.8
EtOH from NA EtOH plants to refueling stations	98.5

Efficiencies for pipeline transportation of G.H₂ are low because a large quantity of G.H₂ needs to be compressed and moved (because of the low volumetric energy content of G.H₂ at atmospheric pressure). Transportation of L.H₂ has low efficiencies because of the low energy content of L.H₂ and the boiling-off loss of L.H₂ during transportation. Ethanol's low transportation efficiency is attributable to the use of trucks to transport a large quantity of ethanol to refueling stations.

1.3 Results

We analyzed 75 fuel pathway options in this study (see Table 1.5). In this report, we present results for 30 representative pathways. The 30 representative pathways are indicated by an "X" in Table 1.5; results for each representative pathway are illustrated in the graphs in this section. Volume 3 of this report series provides results for all 75 of the pathways analyzed.

As the table shows, Argonne assumed that NA plants that produce methanol, FTD, FT naphtha, G.H₂, and L.H₂ could be designed to co-produce steam or electricity for export. On the other hand, we assumed that NNA plants may be designed to co-generate only electricity for export. For NNA plants with FG as feed, we did not assume co-generation of steam or electricity.

For electricity generation, we included the U.S., the California, and the Northeast U.S. generation mixes to illustrate energy and emission effects of various electric generation mixes. We included NG-fired CC turbines, which are energy-efficient and which currently supply incremental electricity demand to many U.S. areas. For hydrogen (H₂) production via

electrolysis, we included electricity generation from nuclear and hydroelectric power to show the effects of air-pollution-free electricity generation on H₂ production.

We analyzed four pathway options for corn-based ethanol, depending on milling technology and the manner of addressing ethanol co-products. Besides E100 (pure ethanol) for FCV applications, we included E85 (85% ethanol and 15% gasoline) for internal combustion engine (ICE) applications. (Note: Because ethanol contains about 5% gasoline as a denaturant for ICE applications, in our analysis, E85 actually contains about 80% ethanol and 20% gasoline.)

In selecting the 30 pathways for presentation here, we did not include fuel plant designs with steam or electricity co-generation. These design options provide additional energy and emissions benefits for the fuels evaluated here (namely, G.H₂, methanol, FT naphtha, and FTD), but whether these options are considered appropriate depends on the specific plant location relative to an energy infrastructure and potential customers. We also eliminated all pathways based on flared gas. Flared-gas-based pathways offer significant energy and emissions benefits; however, the amount of flared gas represents a small portion of the resource base. Results of all eliminated pathways are presented in Volume 3 of this report series. The following paragraphs discuss the results in terms of total energy use, fossil energy use, petroleum use, and GHG emissions.

Table 1.5 Fuel Pathway Options Analyzed in Argonne’s WTT Study and Selected for Presentation in This Report

Fuel Pathways	Selected for Presentation (indicated by X)
<i>Petroleum-Based</i>	
(1) Conventional (current) gasoline (CG)	X
(2) RFG with MTBE (current federal RFG) (150 ppm sulfur)	
(3) RFG with MTBE (5–30 ppm sulfur)	
(4) RFG with EtOH (5–30 ppm sulfur)	
(5) Low-sulfur (LS) RFG without oxygenate (5–30 ppm sulfur)	X
(6) Conventional diesel (CD)	X
(7) Low-sulfur diesel (15 ppm sulfur)	X
(8) Crude oil naphtha	X
<i>NG-Based</i>	
(9) CNG: NA NG	X
(10) CNG: NNA NG	X
(11) CNG: NNA FG	
(12) MeOH: NA NG ^a	X
(13) MeOH: NA NG ^b	
(14) MeOH: NA NG ^c	
(15) MeOH: NNA NG ^a	X
(16) MeOH: NNA NG ^c	
(17) MeOH: NNA FG ^a	
(18) FTD: NA NG ^a	X
(19) FTD: NA NG ^b	
(20) FTD: NA NG ^c	
(21) FTD: NNA NG ^a	X
(22) FTD: NNA NG ^c	
(23) FTD: NNA FG ^a	
(24) FT naphtha: NA NG ^a	X
(25) FT naphtha: NA NG ^b	
(26) FT naphtha: NA NG ^c	
(27) FT naphtha: NNA NG ^a	X
(28) FT naphtha: NNA NG ^c	
(29) FT naphtha: NNA FG ^a	
(30) G.H ₂ – central plants: NA NG ^a	X

Table 1.5 Fuel Pathway Options Analyzed in Argonne’s WTT Study and Selected for Presentation in this Report (Cont.)

Fuel Pathways	Selected for Presentation (indicated by X)
<i>NG-Based (Cont.)</i>	
(31) G.H ₂ – central plants: NA NG ^b	
(32) G.H ₂ – central plants: NA NG ^c	
(33) G.H ₂ – central plants: NNA NG ^a	X
(34) G.H ₂ – central plants: NNA NG ^c	
(35) G.H ₂ – central plants: NNA FG ^a	
(36) L.H ₂ – central plants: NA NG ^a	X
(37) L.H ₂ – central plants: NA NG ^b	
(38) L.H ₂ – central plants: NA NG ^c	
(39) L.H ₂ – central plants: NNA NG ^a	X
(40) L.H ₂ – central plants: NNA NG ^c	
(41) L.H ₂ – central plants: from NNA FG ^a	
(42) G.H ₂ – stations: NA NG ^a	X
(43) G.H ₂ – stations: NNA NG ^a	X
(44) G.H ₂ – stations: NNA FG ^a	
(45) L.H ₂ – stations: NA NG ^a	X
(46) L.H ₂ – stations: NNA NG ^a	X
(47) L.H ₂ – stations: NNA FG ^a	
<i>Electricity Generation</i>	
(48) Electricity: U.S. generation mix	X
(49) Electricity: CA generation mix	
(50) Electricity: Northeast U.S. generation mix	
(51) Electricity: NA NG-fired CC turbines	X
<i>Electrolysis-Based Hydrogen^d</i>	
(52) G.H ₂ – station: U.S. generation mix	X
(53) G.H ₂ – station: CA generation mix	
(54) G.H ₂ – station: Northeast U.S. generation mix	
(55) G.H ₂ – station: NA NG-fired CC turbines	X
(56) G.H ₂ – station: nuclear power	
(57) G.H ₂ – station: hydroelectric power	
(58) L.H ₂ – station: U.S. generation mix	X
(59) L.H ₂ – station: CA generation mix	
(60) L.H ₂ – station: Northeast U.S. generation mix	
(61) L.H ₂ – station: NA NG-fired combined-cycle turbines	X
(62) L.H ₂ – station: nuclear power	
(63) L.H ₂ – station: hydroelectric power	
<i>Ethanol Options</i>	
<i>E-100 (pure ethanol)</i>	
(64) Dry mill, displacement	
(65) Dry mill, market value	
(66) Wet mill, displacement	
(67) Wet mill, market value	X
(68) Woody cellulose	X
(69) Herbaceous cellulose	X
<i>E-85^e</i>	
(70) Dry mill, displacement	
(71) Dry mill, market value	
(72) Wet mill, displacement	
(73) Wet mill, market value	
(74) Woody cellulose	
(75) Herbaceous cellulose	

^a Without steam or electricity co-generation.

^b With steam co-generation.

^c With electricity co-generation.

^d In the case of electrolysis, water is converted to hydrogen and oxygen through the use of electricity, so both water and electricity are treated as feedstocks.

^e Ethanol contains 5% gasoline as a denaturant.

1.3.1 Total Energy Use

Total energy use from fuel production, i.e., WTT, includes use of all energy sources (non-renewable and renewable). Figure 1.14 presents two bars for each of the four electrolysis H₂ options and the two electricity options. The blank bars, which represent normal results for GREET simulations, include both energy losses from WTT and energy contained in the fuel delivered; the solid bars represent energy losses only. The latter are provided here to allow comparison of all fuels on a consistent basis and should be used for discussions concerning WTT results of this study. The information presented in the solid bars was used in the WTW integration process in this study. Similarly, Figure 1.15 presents two bars for each of the electrolysis H₂ and electricity options for fossil energy use. Again, the solid bars in Figure 1.15 should be used for discussions concerning WTT results.

We found that petroleum-based fuels and CNG offer the lowest total energy use for each unit of energy delivered to vehicle tanks (see Figure 1.14, in which the tops and bottoms of the bars indicate the 80 and 20 percentiles, respectively). NG-based fuels (except CNG) generally use the greatest amount of total energy. The fuels with the highest energy use are L.H₂ (production in both central plants and refueling stations), G.H₂ and L.H₂ production via electrolysis, and electricity generation. L.H₂ suffers large efficiency losses during H₂ liquefaction. H₂ production via electrolysis suffers two large efficiency losses: electricity generation and H₂ production.

Total energy use by electricity generation is reduced when using NG-fired CC turbines rather than the U.S. electric generation mix because the average conversion efficiency of existing U.S. fossil fuel plants is 32–35%; the conversion efficiency of NG-fired CC turbines is over 50%.

Use of non-North-American NG for NG-based fuel production results in slightly higher total energy use than does use of North American NG, because transportation of liquid fuels to the United States consumes additional energy. In the cases of CNG, G.H₂, and station-produced L.H₂, the requirement for NG liquefaction for shipment of NNA gas sources to North America causes additional energy efficiency losses.

1.3.2 Fossil Energy Use

Fossil fuels include petroleum, NG, and coal — the three major nonrenewable energy sources. Except for ethanol pathways, the patterns of fossil energy use are similar to those of total energy use (see Figure 1.15). For woody and herbaceous (cellulosic) ethanol pathways, the difference is attributable to the large amount of lignin burned in these ethanol plants. We accounted for the energy in lignin in calculating total energy use, but not in calculating fossil energy use. So fossil energy use is much lower than total energy use for the two cellulosic ethanol pathways.

For electricity generation and H₂ production via electrolysis, fossil energy use between the U.S. generation mix and NG-fired CC turbines is very similar because, while the U.S. generation mix has an overall conversion efficiency lower than that of CC turbines, some non-fossil fuel power plants under the U.S. average mix (such as nuclear and hydroelectric power plants) do not contribute to fossil energy use.

1.3.3 Petroleum Use

As expected, production of all petroleum-based fuels involves high petroleum use (see Figure 1.16). Methanol pathways have relatively high petroleum use because trucks and rails are used to transport a large quantity of methanol.

For electricity generation and H₂ production via electrolysis, we observed a large reduction in petroleum use from the U.S. average generation mix to NG-fired CC turbines because, under the U.S. generation mix, some (a small amount) electricity is generated by burning residual oil. In addition, mining and transportation of coal consume a significant amount of oil.

The high petroleum use for centrally produced G.H₂, relative to station-produced G.H₂, is attributable to the fact that the former is compressed in refueling stations with electric compressors only, while the latter is compressed by means of both electric and NG compressors. Electricity pathways also consume some petroleum.

The amount of petroleum use for the three ethanol pathways is similar to the amounts used for the petroleum gasoline pathways because of the large amount of diesel fuel that is consumed during farming and transportation of corn and cellulosic biomass. The amount of petroleum used for the herbaceous cellulosic ethanol pathway is less than that used for the corn ethanol and woody cellulosic ethanol pathways because corn ethanol consumes a relatively large amount of diesel fuel and because transportation of woody biomass, which has high moisture content, consumes more energy than does transportation of herbaceous biomass.

1.3.4 Greenhouse Gas Emissions

Figure 1.17 shows the sum of WTT CO₂-equivalent emissions of CO₂, CH₄, and N₂O. Petroleum-based fuels and CNG produced from North American NG are associated with low WTT GHG emissions because of their high production efficiency. CNG from NNA NG has relatively high GHG emissions because of CH₄ emissions generated from liquid NG boiling-off and leakage during transportation (CH₄, a GHG, is 21 times as potent as CO₂). Methanol and FT fuels have high GHG emissions because of CO₂ emissions during fuel production that result from their low production efficiency relative to that of petroleum-based fuels.

All H₂ pathways have very high GHG emissions because all of the carbon in NG feedstock is removed during H₂ production, for which we did not assume carbon sequestration. For the electrolysis cases, CO₂ releases during electricity generation (attributable to fossil-fueled generation) are significant. L.H₂ production, electrolysis H₂ (both gaseous and liquid), and electricity generation have the highest GHG emissions. Relative to emissions from NG-fired CC turbine plants, there is a large increase in GHG emissions from the U.S. average electric generation mix, primarily because of the high GHG emissions from coal- and oil-fired electric power plants. Coal- and oil-fired plants contribute a large share of the U.S. average.

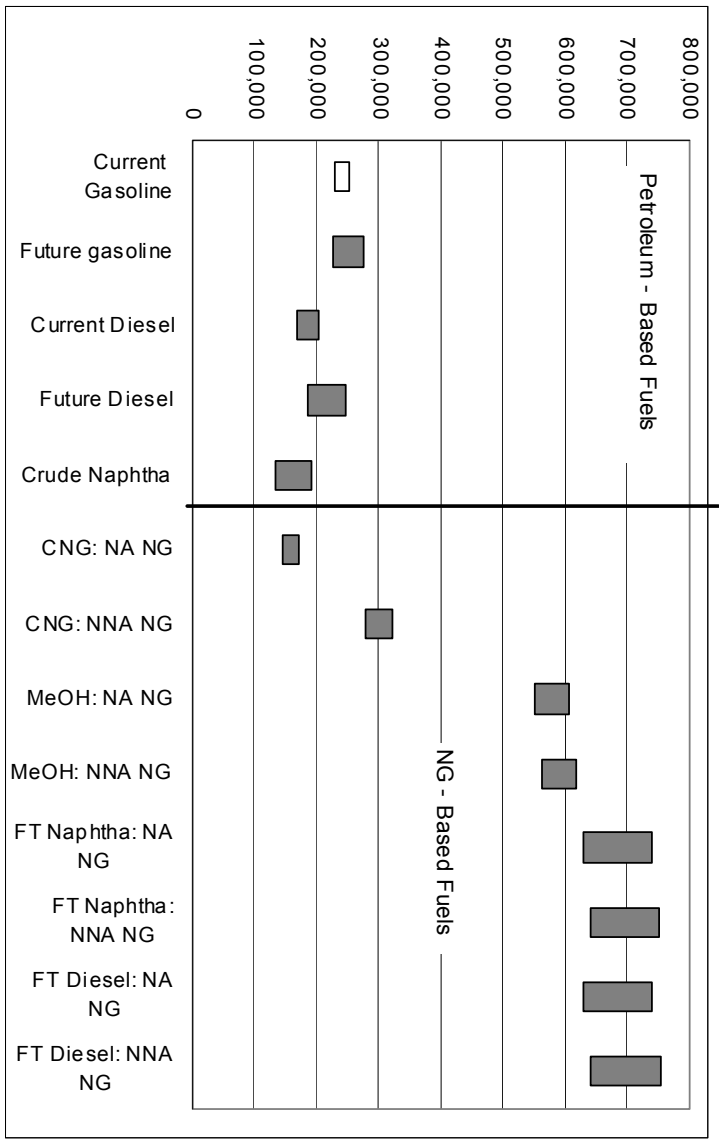
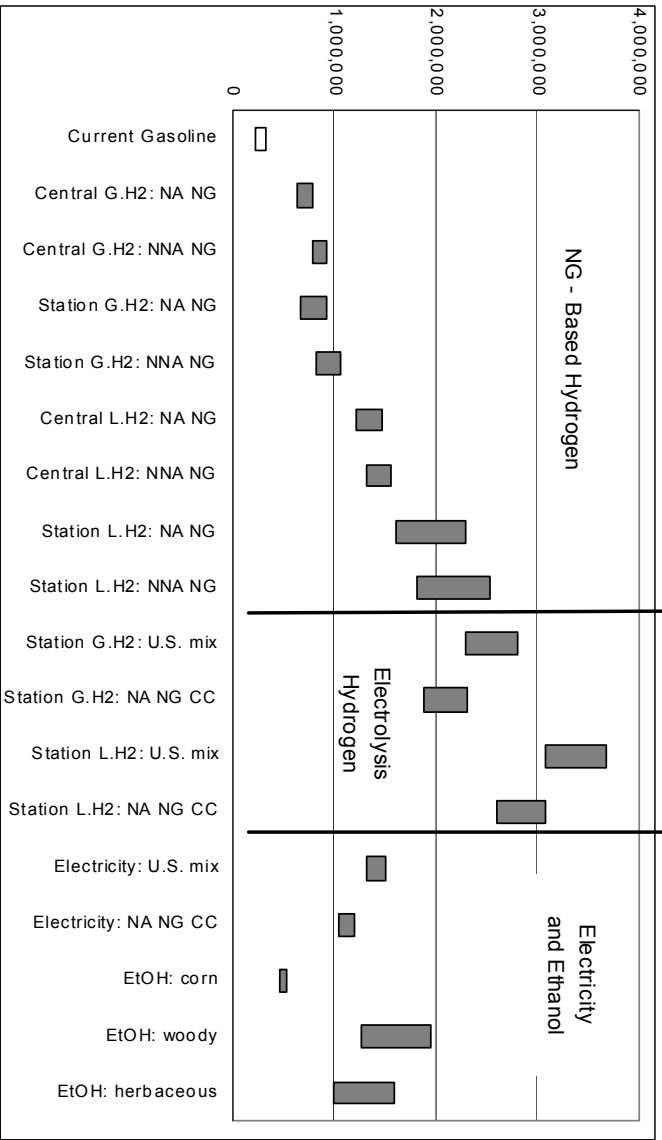
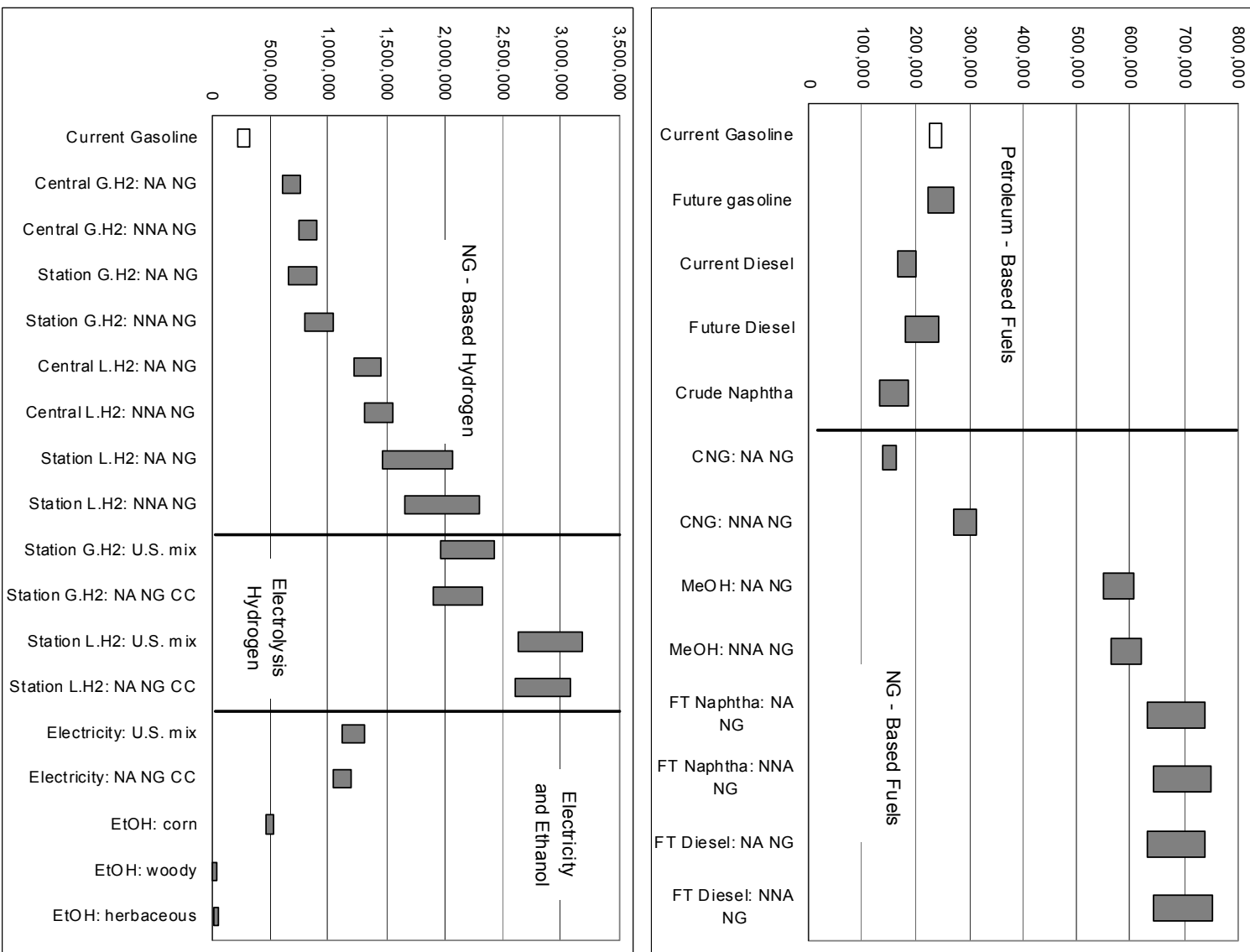

Figure 1.14 WTT Total Energy Use (Btu/mmbtu) of fuel delivered to vehicle tanks)

Figure 1.15 WTT Fossil Energy Use (Btu/mmBtu of fuel delivered to vehicle tanks)



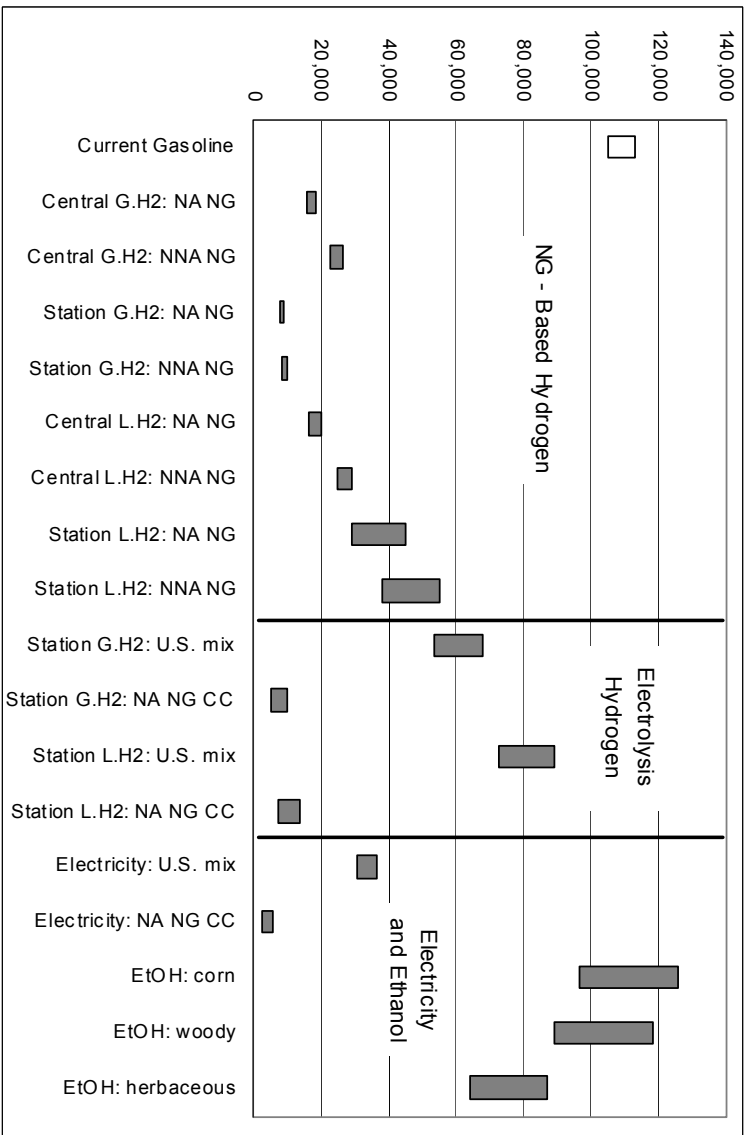
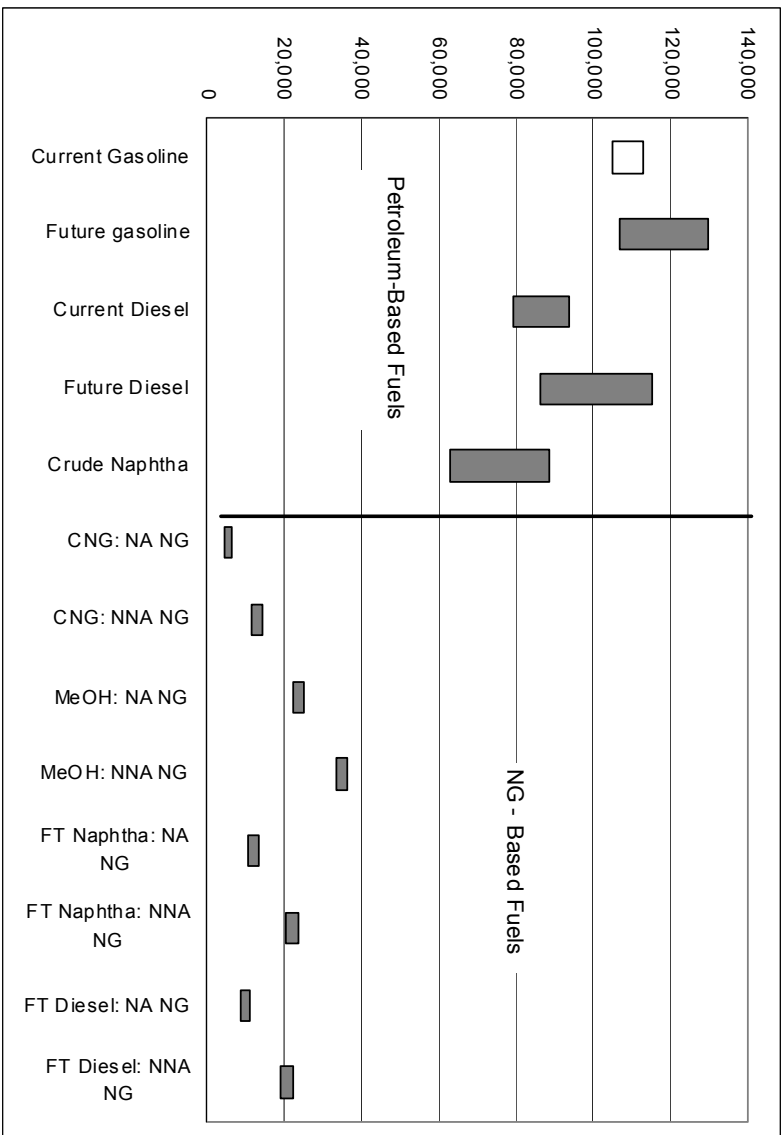

Figure 1.16 WTT Petroleum Use (Btu/mmBtu) of fuel delivered to vehicle tanks)

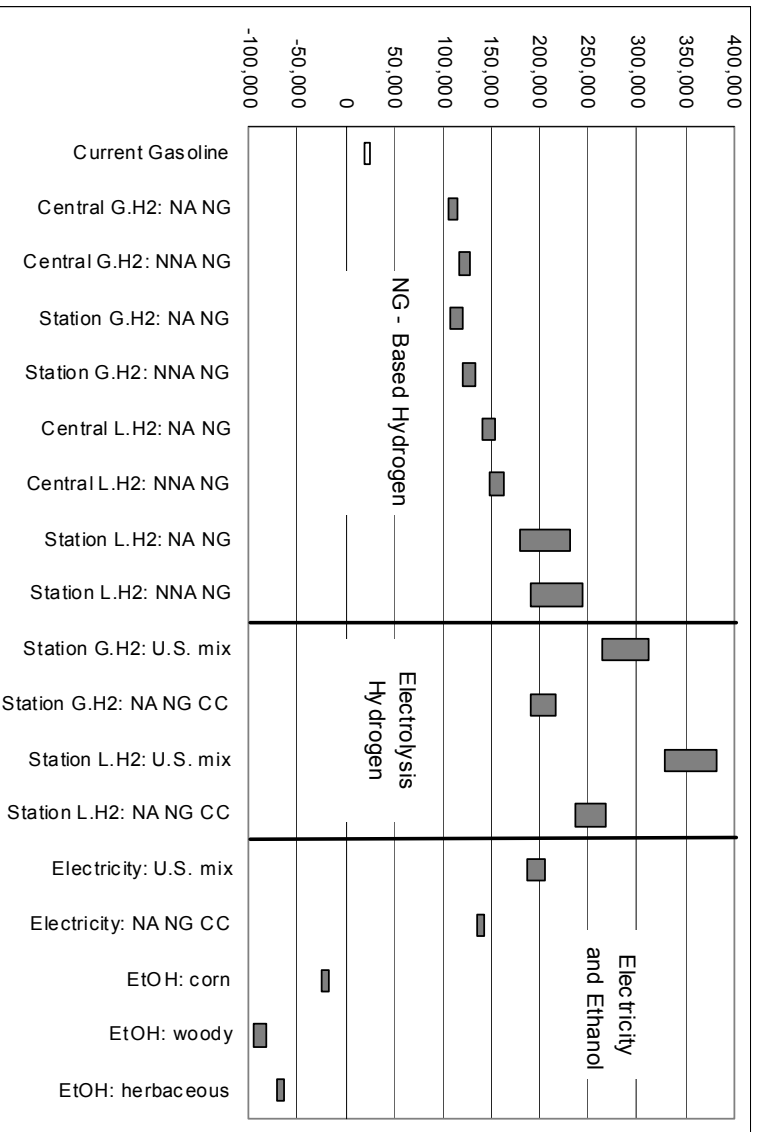
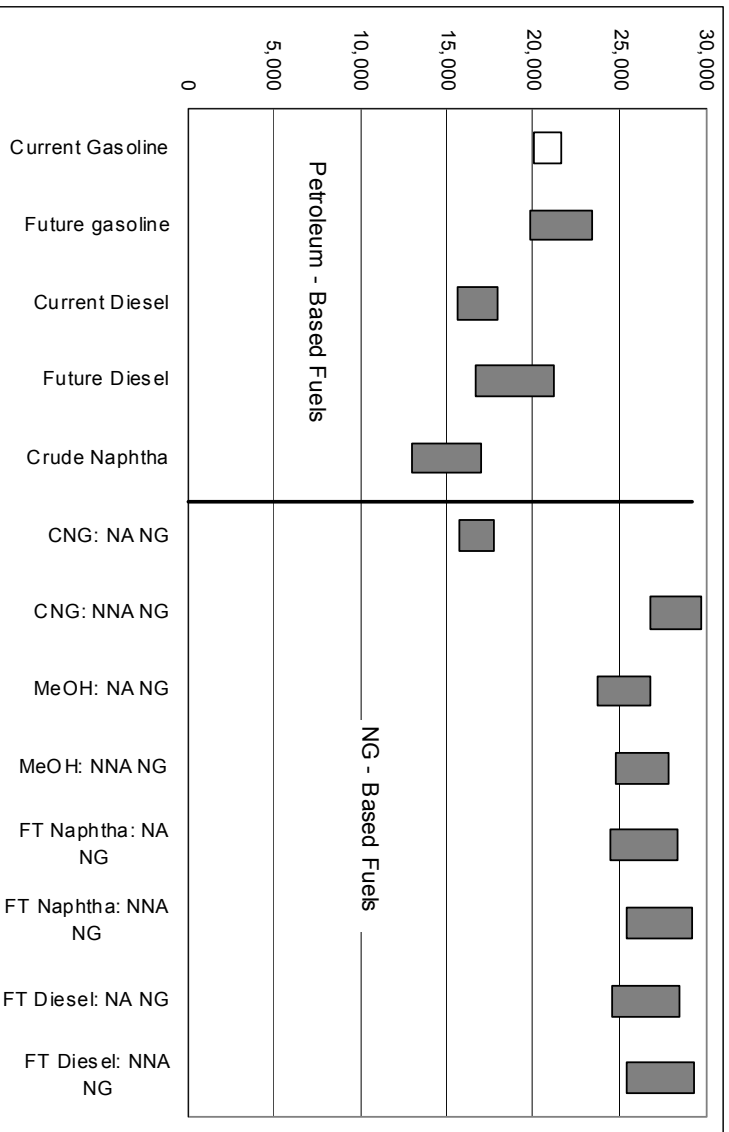

Figure 1.17 WTT GHG Emissions (g/mmBtu of fuel delivered to vehicle tanks)

The three ethanol pathways have negative GHG emissions because of carbon uptake sequestration during growth of corn plants, trees, and grass. Corn ethanol has smaller negative GHG values because use of fossil fuels during corn farming and in ethanol plants offsets some of the CO₂ sequestered during growth of corn plants. All the carbon sequestered during biomass growth is released back to the air during combustion of ethanol in vehicles, which is accounted for in the integration of well-to-tank and tank-to-wheel in Part 3.

1.4 Conclusions

Our WTT analysis resulted in the following conclusions. It is important to remember that WTT results are incomplete in evaluating fuel/propulsion systems. The systems must be evaluated on a WTW basis; this analysis is presented in Part 3 of this volume.

- *Total Energy Use.* For the same amount of energy delivered to the vehicle tank for each of the fuels evaluated in our study, petroleum-based fuels and CNG are subject to the lowest WTT energy losses. Methanol, FT naphtha, FTD, and G.H₂ from NG and corn-based ethanol are subject to moderate WTT energy losses. Liquid H₂ from NG, electrolysis H₂ (gaseous and liquid), electricity generation, and cellulosic ethanol are subject to the largest WTT energy losses.
- *Fossil Energy Use.* Fossil energy use — including petroleum, NG, and coal — follows patterns similar to those for total energy use, except for cellulosic ethanol. Although WTT total energy use of cellulosic ethanol production is high, its fossil energy use is small because cellulosic ethanol plants burn lignin, a non-fossil energy, for needed heat.
- *Petroleum Use.* Production of all petroleum-based fuels requires a large amount of petroleum. Electrolysis H₂ (with the U.S. average electricity) and the three ethanol pathways consume an amount of petroleum about equal to that consumed by petroleum-based fuels. NG-based fuel pathways require only small amounts of petroleum.
- *Greenhouse Gas Emissions.* Production of petroleum-based fuels and NG-based methanol, FT naphtha, and FTD results in a smaller amount of WTT GHG emissions than production of H₂ (gaseous and liquid) and electricity generation. WTT GHG emission values of the three ethanol pathways are negative because of carbon uptake during growth of corn plants, trees, and grass.

Overall, our WTT analysis reveals that petroleum-based fuels have lower WTT total energy use than do non-petroleum-based fuels. L.H₂ production (in both central plants and refueling stations) and production of G.H₂ and L.H₂ via electrolysis can be energy-inefficient and can generate a large amount of WTT GHG emissions. Cellulosic ethanol, on the other hand, because it is produced from renewable sources, offers significant reductions in GHG emissions. The other fuels options examined here have moderate WTT energy and GHG emissions effects.

1.5 Acknowledgments

Argonne's WTT work was funded by the Global Alternative Propulsion Center of GM. Argonne would like to acknowledge guidance and input from the GM project managers, Dr. Tony Finizza, Dr. Jim Wallace, and Greg Ruselowski. We are grateful to Dr. James Simnick and Andrew Armstrong of BP, Gilbert Jersey and Dr. John Robbins of ExxonMobil, Norman Brinkman of the

GM R&D Center, and Jean Cadu of Shell for their input to and review of this report. We would also like to thank our Argonne colleagues Marianne Mintz, Dan Santini, and Chris Saricks for their input.

Finally, Argonne would like to thank Tien Nguyen, Dr. Phillip Patterson, and David Rodgers of the U.S. Department of Energy's Office of Transportation Technologies; without their support of previous versions of the GREET model, this study would not have been possible. We would also like to acknowledge the excellent editorial support of Mary Fitzpatrick of Argonne.

Part 2

Tank-to-Wheel Energy Utilization for a North American Vehicle

Trudy R. Weber
Thermal and Energy Systems Lab
GM R&D and Planning Center

Gerald D. Skellenger
Electrical and Controls Integration Lab
GM R&D and Planning Center

David A. Masten
Global Alternative Propulsion Center
General Motors Corporation

June 2001

2.1 Introduction

The purpose of this study, conducted by General Motors R&D and Planning Center and General Motors Corporation, was to quantify the tank-to-wheel energy use of advanced conventional and unconventional powertrain systems, focusing on technologies that are expected to be implemented in 2005 and beyond. These technologies were assessed on the basis of their potential for improving fuel economy while maintaining vehicle performance. The propulsion systems included in this study were a conventional powertrain (with gasoline, diesel, E85, and CNG engines), a parallel electric hybrid powertrain (using gasoline, diesel, and E85 engines), and direct and battery-hybrid fuel cell systems (with reformers for gasoline, methanol, and ethanol, and without reformers). Each of the vehicle architectures was modeled and designed to meet a set of specified performance requirements, such as maximum launch acceleration, 0–60 mile per hour (mph) time, passing maneuvers, and gradeability. Dominant among these requirements in sizing the powertrain and selecting appropriate ratios were the peak acceleration and top speed of the vehicle.

The baseline vehicle selected for this study was a full-size pickup truck. We employed vehicle simulation models using validated GM proprietary component characteristics to establish the fuel economy and energy required on the EPA urban and highway duty cycles. The GM proprietary Hybrid Powertrain Simulation Program (HPSP) vehicle simulation model was used to design and analyze each vehicle concept.

This report briefly discusses each of these vehicle models and the assumptions made in our simulations and presents the fuel economy and performance predictions based on this input.

Figure 2.1 illustrates how the energy is used in a typical pickup truck while negotiating EPA's urban and highway driving cycles. Advanced powertrain technologies are targeted at reducing the engine and driveline losses, eliminating the braking losses through regeneration and hybrid technologies, and powering the accessories with advanced energy management strategies. Advanced vehicle-level technologies impact the mass and the aerodynamic and rolling resistance losses.

2.2 Methodology

The HPSP is a GM-proprietary tool that, with an extensive database of proprietary component maps, can model any conventional or advanced vehicle architecture or powertrain technology.

Figure 2.2 provides an overview of the HPSP modeling and simulation approach. The model simulates power and energy flows in the vehicle driveline while capturing all losses and inefficiencies in the components and subsystems.

The model implements a “backward-driven” approach, which uses the driving cycle velocity profile to determine the road-load and acceleration requirements of the vehicle (Weber 1988; Rohde and Weber 1984). The algorithm then works its way backward through all the powertrain components, taking losses into account along the way. In this way, the output requirement(s) at the energy source(s) (i.e., fuel tank, battery, or both) are used to determine the vehicle fuel consumption. If present in the component data, emissions may be integrated over the duty cycle;

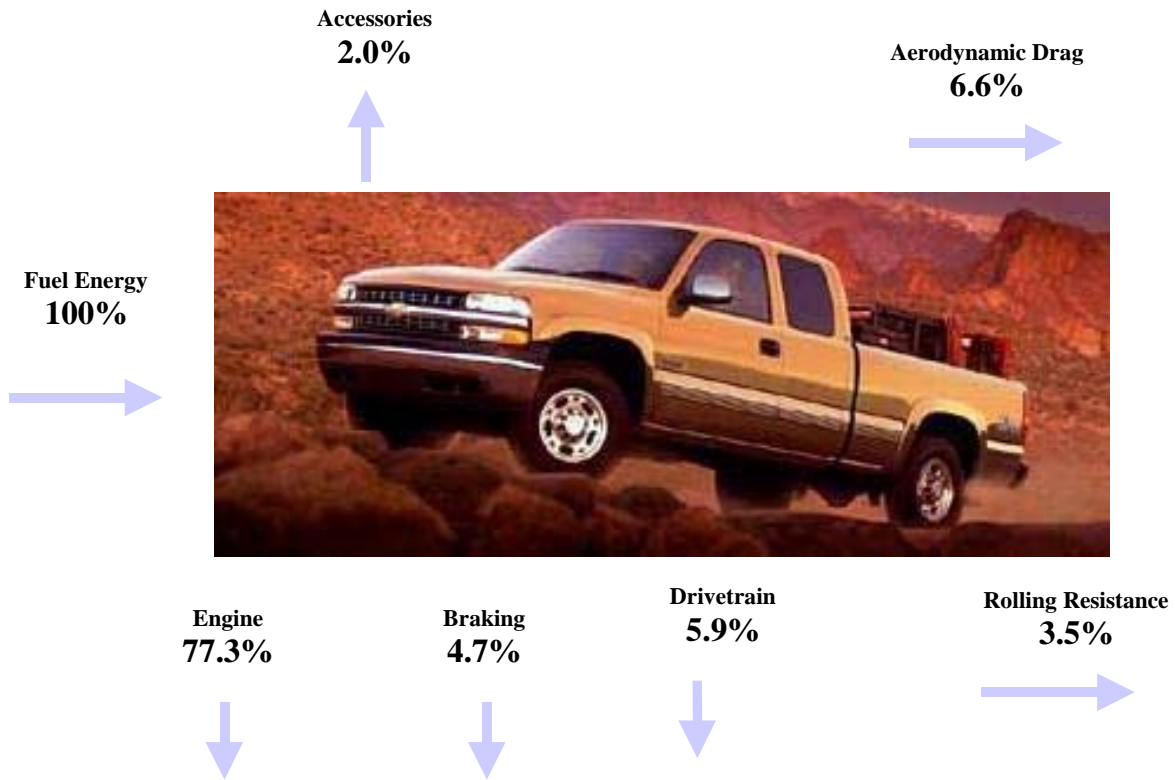

Figure 2.1 Energy Use in a Pickup Truck

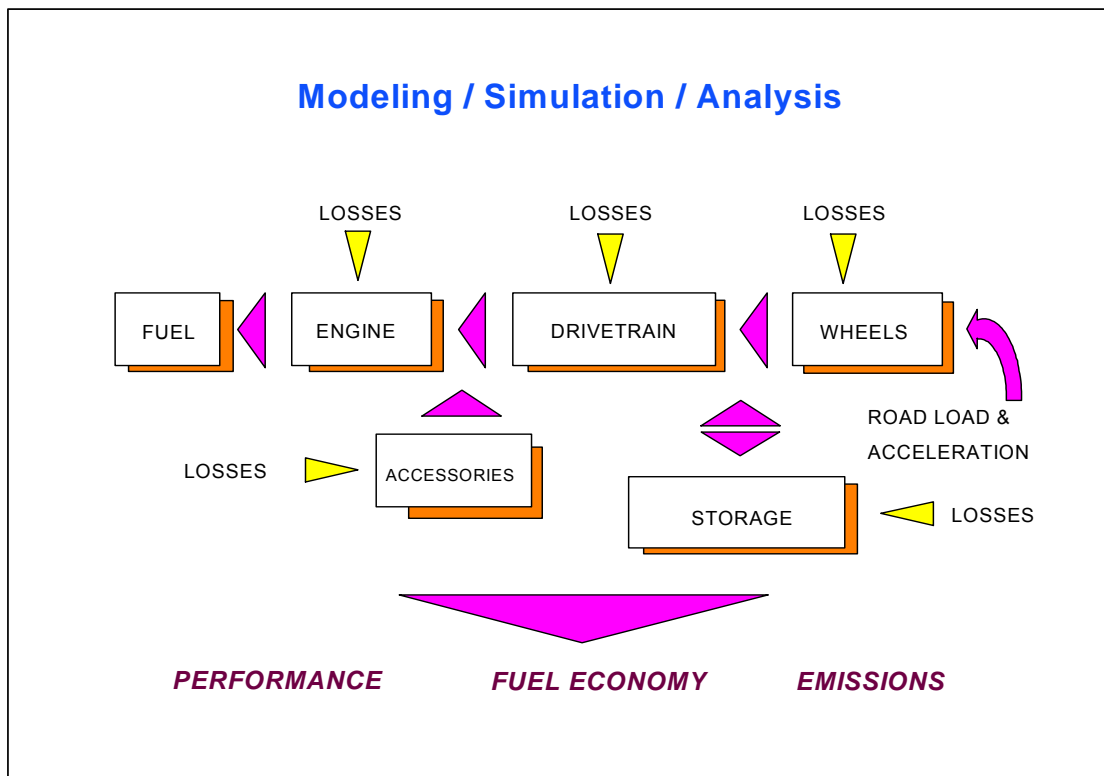

Figure 2.2 HPSP Methodology

however, emissions were not simulated in this work. Instead, the various vehicles were postulated to satisfy certain tailpipe emission classes, as shown in the results provided in Section 2.3.

By iterating on the acceleration response of the vehicle until the full power levels of the engine are reached, we can establish the maximum performance for a specified powertrain in the same manner.

The HPSP simulation models have been validated on numerous occasions for conventional and for hybrid drive systems. When component maps, vehicle parameters, and control strategies implemented in a vehicle were input into the vehicle model, the measured fuel economies in the vehicle were consistently within 1% of the model predictions. In addition to conventional vehicles, the following unconventional architectures were validated: the EV1 electric car, the Freedom Series hybrid vehicle (Skellenger et al. 1993), and the Partnership for a New Generation of Vehicles (PNGV) Precept concept car.

Conventional and hybrid powertrains were modeled in this environment by the appropriate inclusion of energy transfer and energy storage devices (i.e., batteries). Component efficiency characteristics and assumptions regarding the control and energy management strategies were kept consistent among all vehicle models. Figure 2.3 illustrates, through sample output for a hypothetical vehicle, the type of information that was generated and analyzed for the various vehicles during our study.

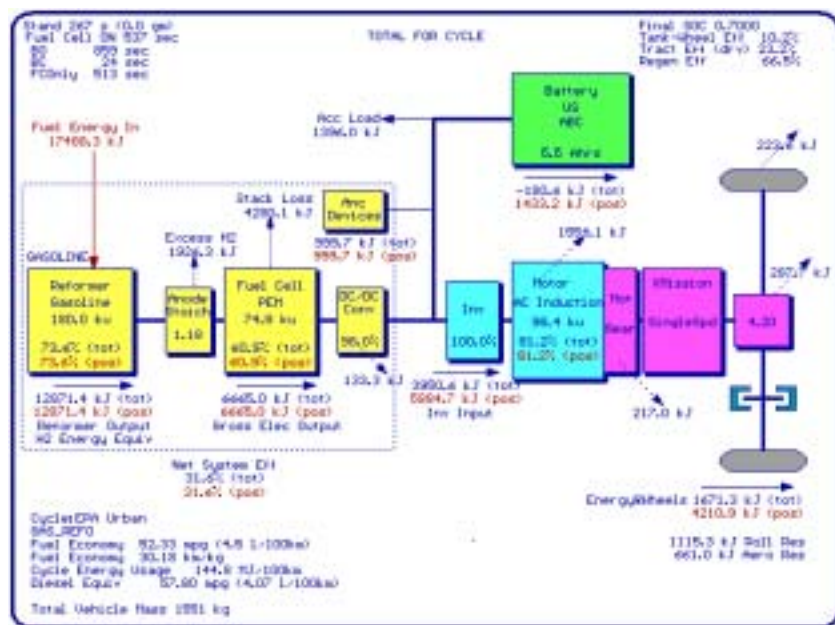

Figure 2.3 Sample Energy Use Diagram Provided by HPSP

2.2.1 Vehicle Architectures

The following vehicle architectures and fuels were included in GM's TTW study:

1. Conventional (CONV) vehicle with spark ignition (SI) gasoline engine (baseline)
2. CONV vehicle with compression ignition direct injection (CIDI) diesel engine
3. CONV vehicle with SI E85 (a mixture of 85% ethanol and 15% gasoline by volume) engine
4. CONV vehicle with SI compressed natural gas (CNG) engine
5. Charge-sustaining (CS) parallel hybrid electric vehicle (HEV) with gasoline engine
6. CS parallel HEV with CIDI diesel engine
7. CS parallel HEV with SI E85 engine
8. Gasoline fuel processor (FP) fuel cell vehicle (FCV)
9. Gasoline FP fuel cell (FC) HEV
10. Methanol FP FCV
11. Methanol FP FC HEV
12. Ethanol FP FCV
13. Ethanol FP FC HEV
14. Gaseous hydrogen (GH₂)/liquid hydrogen (LH₂) FCV
15. GH₂/LH₂ FC HEV

Figure 2.4 illustrates the powertrain architecture for the conventional vehicle that is considered the baseline vehicle for this study. A multi-speed manual, automatic, or continuously variable transmission (CVT) may be incorporated, and a torque converter or starting clutch may be used for launching the vehicle. The engine model, which consists of a brake-specific fuel consumption (BSFC) map, can represent any desired technology level and/or can be adjusted to any displacement. HPSP provides engine scaling and sizing capabilities, and constraints on engine operating conditions can be imposed. In this study, the baseline vehicle powertrain consisted of a gasoline engine and a 4-speed automatic transmission with a torque converter. A diesel engine with the same transmission in this conventional architecture represents case 2 in the above list; cases 3 and 4 are the conventional engine running on E85 ethanol and on CNG.

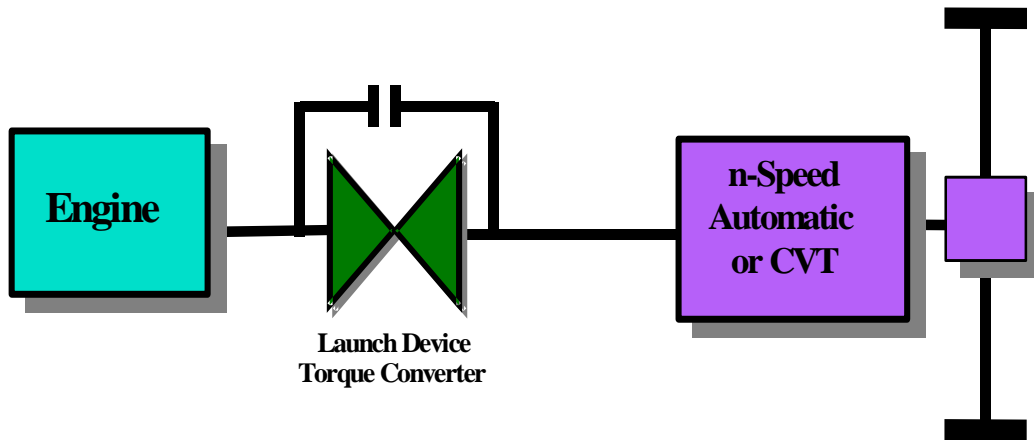

Figure 2.4 Conventional Powertrain

The parallel hybrid architecture for cases 5 through 7 is shown in Figure 2.5. It is an input power-assist HEV with an electric drive at the transmission input. This concept may or may not include a torque converter, and the transmission can be any type. For this study, we used a 4-speed automatic transmission with a starting clutch for launching the vehicle. We assumed that the electric drive could replace the torque converter and assist the engine for maximum vehicle acceleration performance. The energy management strategy implemented for maximizing the fuel economy was a charge-sustaining strategy with fuel shut-off during standstill and deceleration periods and with battery launch at low acceleration demands. Gasoline, E85, and diesel engines were evaluated in this architecture.

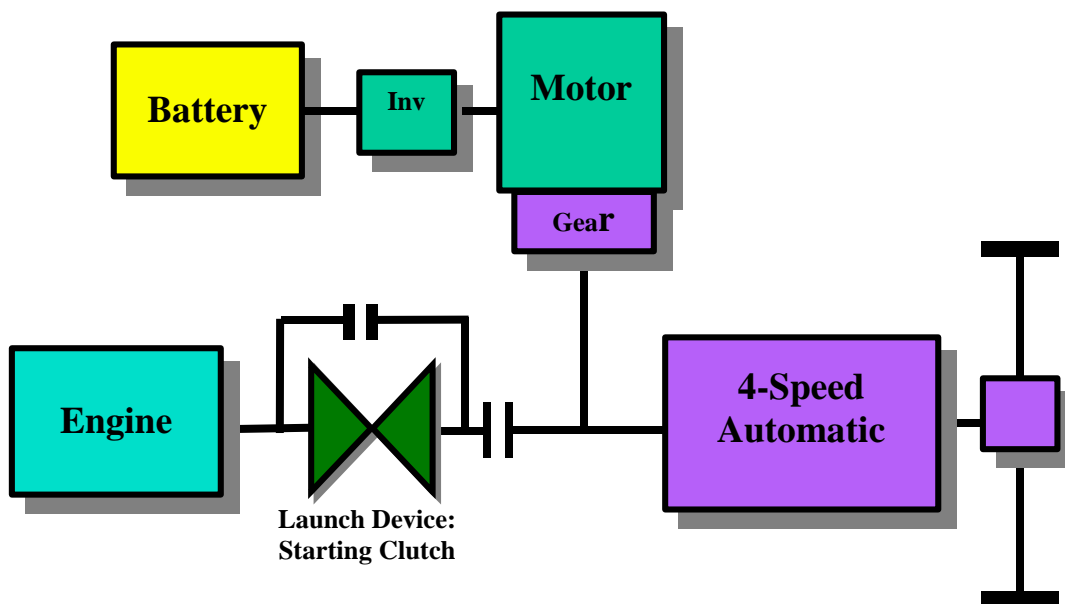

Figure 2.5 Parallel Hybrid (Input Power Assist)

Internal combustion engine series hybrids were not considered in this study. First, because the 7.5-mile all-electric range can be met with a relatively small battery pack and moderately sized electric drive, thereby eliminating one of the drivers toward the series architecture. Furthermore, it is GM's experience that, when trying to maximize fuel economy in a hybrid vehicle, parallel

hybrids most often emerge triumphant because the efficiency of the mechanical transmission path is greater than the efficiency of any electrical path. Finally, the FC hybrids (Cases 9, 11, 13, and 15) are series electric hybrids, and the energy conversion efficiency of a FC stack is noticeably greater than that of a combustion engine. Therefore, the FC series hybrids would consume less fuel than their ICE counterparts; therefore, there was no need to carry a series ICE HEV concept forward.

Cases 8 through 13 are FP systems in direct-drive and HEV powertrain architectures using gasoline, methanol, and ethanol as the fuel of choice. The subsystems included in the FP system models are shown in Figures 2.6 and 2.7 for the direct and the HEV vehicle architectures. Each component in the diagrams was characterized with efficiency data as a function of transmitted power.

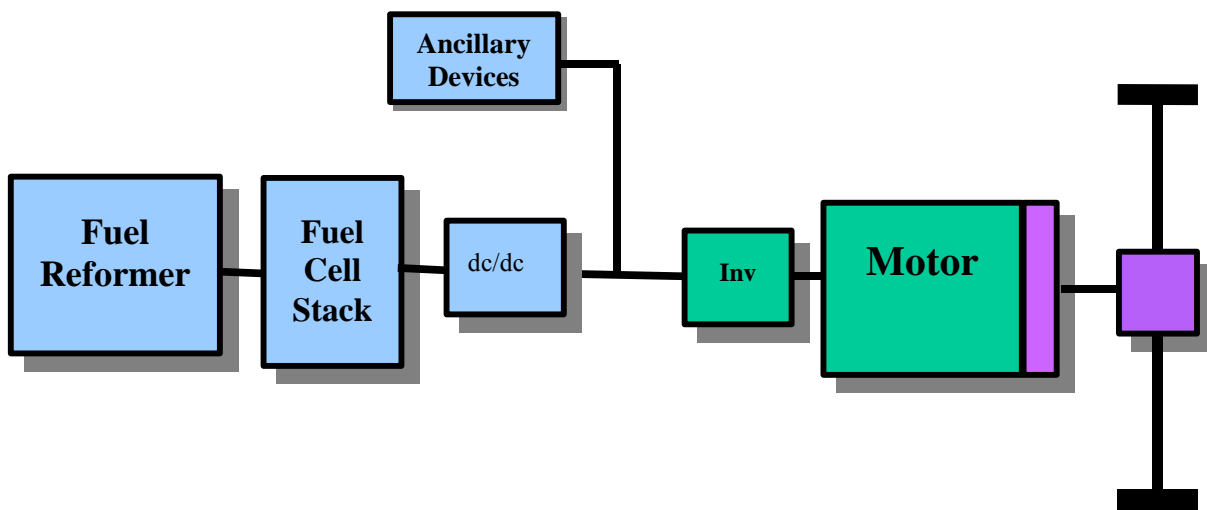

Figure 2.6 Fuel Processor Fuel Cell Vehicle System

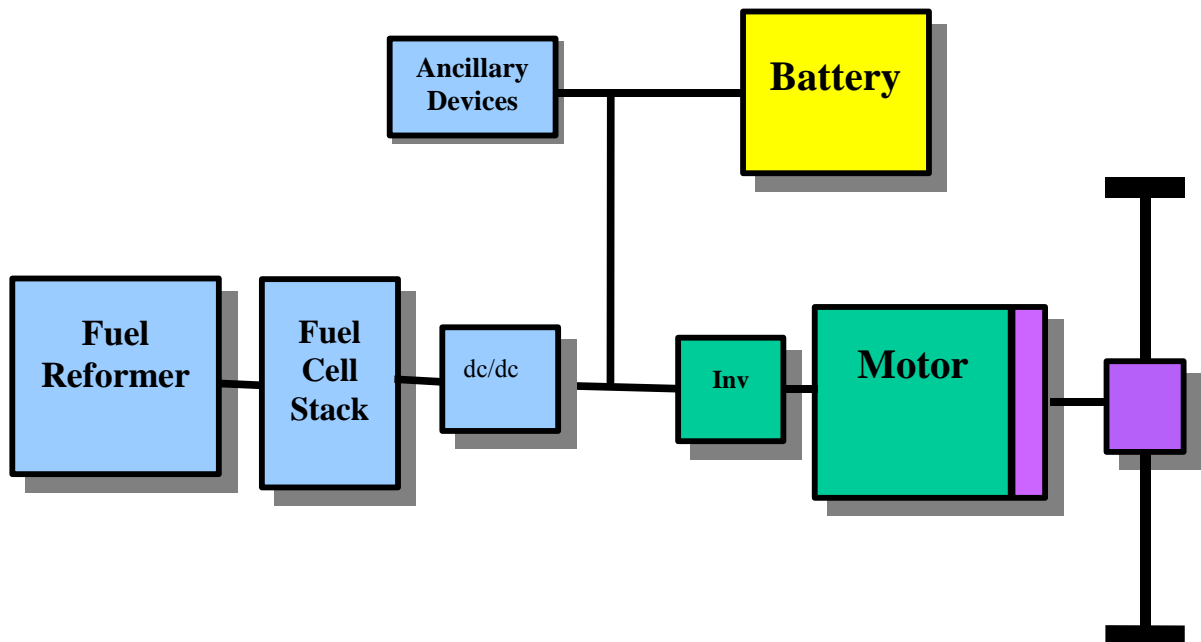

Figure 2.7 Fuel Processor Fuel Cell HEV System

Cases 14 and 15 are the direct FC and the FC HEV systems modeled and analyzed in this study. Figures 2.8 and 2.9 capture the components used in these concepts. The FP and FC HEV systems were also optimized with charge-sustaining energy management strategies.

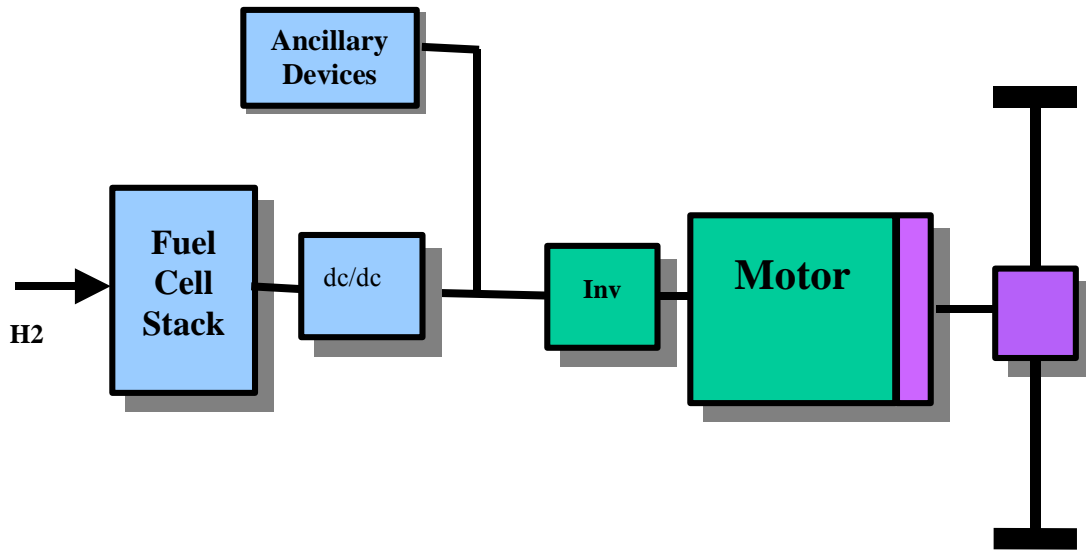

Figure 2.8 Direct Fuel Cell Vehicle System

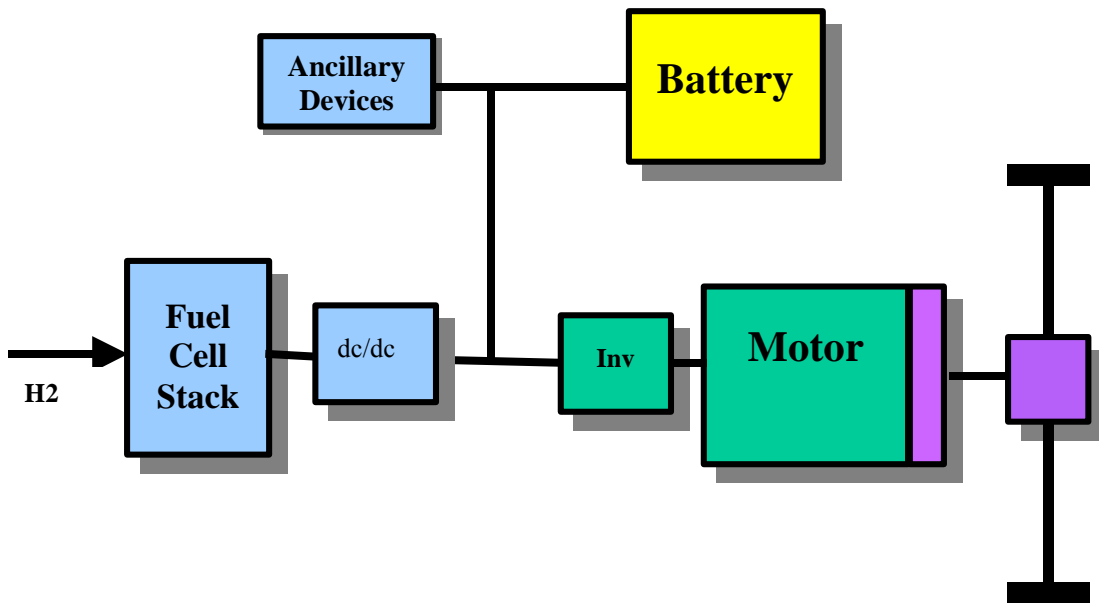

Figure 2.9 Direct Fuel Cell HEV System

2.2.2 Vehicle Criteria

2.2.2.1 Performance Targets

The performance targets shown in Figure 2.10 were the drivers in the powertrain sizing process. These metrics were evaluated through simulations and served as the design criteria for each vehicle concept.

We also required that the vehicles suffer no performance degradation because of a lack of available energy from the battery (i.e., avoiding the so-called “turtle” effect). In essence, the fuel converter (engine or FC) must remain at the same power level whether or not batteries are present. The ability of each technology to meet this criterion was tested by simulating the vehicle over 10 successive US06 driving cycles with no recharge of the battery permitted at the end of the run.

The preceding restriction also led toward a relatively small battery pack, which rendered charge-depleting hybrids and battery electric vehicles impractical with all available battery technology. For the hybrid vehicles, the battery was sized to drive one urban cycle on batteries providing only about 7.5 miles Zero Emissions Vehicle (ZEV) range.

The most dominant parameter affecting the performance of a vehicle is its mass. The vehicle mass was consistently estimated on the basis of battery and motor size, known engine and transmission masses, and projected FC system masses. The motors were sized to either achieve or assist in achieving the vehicle performance metrics shown in Figure 2.10; the maximum acceleration of 5 m/s/s was dominant among these design constraints. The final drive and motor ratios were selected to meet the top vehicle speed requirement.

Having determined the vehicle mass (based on component sizes) that met the specified performance requirements, we optimized the powertrain operation on the driving cycles by implementing energy management and control strategies to achieve maximum fuel economy for each vehicle concept. We imposed constraints on component operation (e.g., engine, accessories, motors, batteries) reflecting vehicle driveability and comfort requirements to provide more realistic and realizable fuel economy projections.

2.2.2.2 Emissions Targets

Emissions targets for all vehicles were based on Federal Tier 2 standards, which are divided into eight emission level categories (or bins) for the 2010 timeframe, when the Tier 2 standards are completely phased in. Bin 5 standards were selected for all vehicles with ICEs because they represent the fleet average. Bin 5 standards are also consistent with PNGV goals. Bin 2 standards (equivalent to Super Ultra Low Emissions Vehicle [SULEV] II) were selected for the FP (reformer) FC vehicles, and Bin 1 (ZEV) standards were selected for the hydrogen FC vehicles. Compliance with these standards has not been demonstrated; we assumed that considerable advances will be made in the technologies. The impact of emissions control on fuel consumption was included in this analysis.

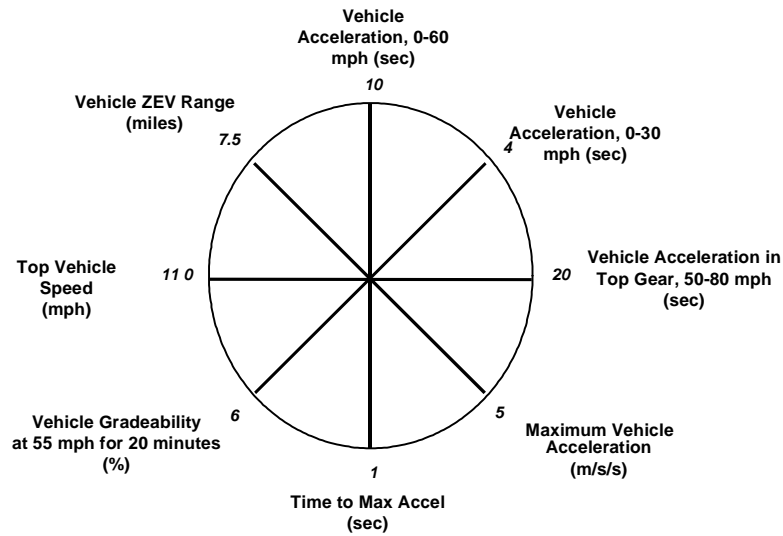

Figure 2.10 Performance Targets

2.2.2.3 Vehicle Simulation Model Input Data

The baseline vehicle design parameters used in the study — such as mass, aerodynamic, and rolling resistance coefficients — were based on a GM full-size pickup truck. Except for the mass, which was adjusted for each vehicle’s propulsion system independently, these vehicle-level parameters were used consistently in all the simulation models.

The electric components used in the models were based on validated maps for the electric drive system, and the nickel metal hydride (NiMH) battery data were based on the GM Precept PNGV vehicle.

FC stack and FP component maps were based on small- to full-scale component data using GM proprietary modeling tools; they were validated on the GM HydroGen-1 FC vehicle. Previous GM FC system and modeling development were reported in Allison Gas Turbine Division and General Motors Corporation 1994; General Motors Corporation 1999; Fronk et al. 2000; and Busshardt et al. 2000. The efficiency maps are based on a combination of present data and relatively near-term (one to two-year timeline) projections. However, we recognize that significant development is required to scale to the large power levels required for this chosen application, specifically thermal and water management, FP dynamics, and startup.

Certain major factors — specifically, packaging, transient response, cold-start performance, and cost — were not taken into consideration in this work. Therefore, the results should not be considered indicative of commercial viability; they should be viewed rather as an initial screening to identify configurations that are sufficiently promising to warrant more detailed studies.

2.3 Results

Table 2.1 summarizes the simulation results for each of vehicle concepts included in this study. The only performance metric reported here is the 0–60 mph performance time, which varies from vehicle to vehicle because the active constraints in each of these designs were maximum launch acceleration and top vehicle speed. Each of these concepts met those requirements; thus, the comparison of fuel economy and 0–60 mph acceleration time reported here can now be made on an “equal-performance” basis.

Table 2.1 Fuel Economy (Gasoline Equivalent) and Performance Predictions

No.	Vehicle Configuration	Urban Fuel Economy (mpg GE) ^a	Highway Fuel Economy (mpg GE)	Complete Fuel Economy (mpg GE)	Gain in Fuel Economy over Baseline (%)	Tank-to-Wheel Efficiency (%)	Time (s to 60 mph)
1	Gasoline CONV SI	17.4	25.0	20.2	Baseline	16.7	7.9
2	Diesel CONV CIDI	20.2	30.4	23.8	18	19.4	9.2
3	E85 CONV SI	17.4	25.0	20.2	0	16.7	7.9
4	CNG CONV SI	17.0	24.7	19.8	-2	16.9	8.2
5	Gasoline SI HEV ^{b,c}	23.8	25.1	24.4	21	20.7	6.3
6	Diesel CIDI HEV ^c	29.1	29.8	29.4	46	24.6	7.2
7	E85 SI HEV ^c	23.8	25.1	24.4	21	20.7	6.3
8	Gasoline FP FCV	26.2	28.6	27.2	35	24.0	10.0
9	Gasoline FP FC HEV	31.9	28.5	30.2	50	27.3	9.9
10	Methanol FP FCV	28.8	32.4	30.3	50	26.6	9.4
11	Methanol FP FC HEV	35.8	33.0	34.5	71	31.1	9.8
12	Ethanol FP FCV	27.5	30.0	28.6	42	25.2	10.0
13	Ethanol FP FC HEV	33.5	29.9	31.8	57	28.7	9.9
14	GH ₂ FCV/ LH ₂ FCV	41.6	45.4	43.2	114	36.3	8.4
15	GH ₂ FC HEV/ LH ₂ FC HEV	51.5	44.5	48.1	138	41.4	10.0

^a GE = gasoline equivalent.

^b All HEVs are charge sustaining.

^c Parallel.

The **Tank-to-Wheel Efficiency** shown in Table 2.1 is a measure of the overall efficiency of the vehicle system, defined as:

$$\text{Tank to Wheel Eff} = \frac{\text{Energy Output}}{\text{Energy Input}}$$

where the energy output of the drive system is defined as the total amount of energy required to overcome the rolling resistance, aerodynamic, and inertial (acceleration) load over the driving cycle:

$$\text{Energy Output} = \sum [(Roll Resist) + (Aero Resist) + (Ma)] * V * \Delta t = \text{Energy@Wheels}$$

and the total amount of energy input to the system is defined as:

$$\text{Energy Input} = \text{Energy Value of Fuel Consumed}$$

Note that the vehicle auxiliary/accessory load is not included in this definition of energy output.

Finally, the vehicle fuel economy (on a gasoline-equivalent basis) and expected emission levels are summarized in Table 2.2. The fuel economy from Table 2.1 is shown here as the “50” entry, meaning that there is a 50% likelihood that the fuel economy may be higher (due to some presently unknown technological advance), or lower (due to unforeseen difficulties). The columns labeled 20 and 80 denote estimates wherein the fuel economy has only a 20% likelihood of being lower than the lower bound and a 20% likelihood of being higher than the higher bound, respectively.

Table 2.2 Overview of Vehicle Configurations

No.	Vehicle Configuration	Fuel Economy (mpg GE)			Emission Standard ^d
		20 percentile ^a	50 percentile ^b	80 percentile ^c	
1	Gasoline CONV SI (baseline)	19.2	20.2	26.3	Tier 2 Bin 5
2	Diesel CONV CIDI	22.0	23.8	30.9	“
3	E85 CONV SI	19.2	20.2	26.3	“
4	CNG CONV SI	18.8	19.8	25.7	“
5	Gasoline SI HEV ^{e,f}	22.2	24.4	30.5	“
6	Diesel CIDI HEV ^f	26.7	29.4	36.8	“
7	E85 SI HEV ^f	22.2	24.4	30.5	“
8	Gasoline FP FCV	23.7	27.2	32.6	Tier 2 Bin 2
9	Gasoline FP FC HEV	26.2	30.2	36.2	“
10	Methanol FP FCV	26.3	30.3	36.4	“
11	Methanol FP FC HEV	30.0	34.5	41.4	“
12	Ethanol FP FCV	24.9	28.6	34.3	“
13	Ethanol FP FC HEV	27.6	31.8	38.2	“
14	GH ₂ FCV/LH ₂ FCV	39.3	43.2	47.5	Tier 2 Bin 1
15	GH ₂ FC HEV/LH ₂ FC HEV	43.7	48.1	52.9	“

^a 20% likelihood mpg lower.

^b Equally likely above or below.

^c 20% likelihood mpg higher.

^d Federal standards: Tier 2 Bin 5, Tier 2 Bin 2 (SULEV II), Tier 2 Bin 1 (ZEV).

^e All HEVs are charge sustaining.

^f Parallel.

2.4 Conclusions

On the basis of the results listed in Table 2.1, GM made the following observations:

- FC systems use less energy than conventional powertrains because of the intrinsically higher efficiency of the FC stack.
- Hybrid systems show consistently higher fuel economy than conventional vehicles because of regenerative braking and engine-off during idle and coast periods (thus, the improvements occur mostly on the urban driving schedule).
- In the case of the FC and FP systems, the gains resulting from hybridization are lower because the “engine-off” mode is present in both systems.
- Hydrogen-based FC vehicles exhibit significantly higher fuel economy than those that employ a FP.

Again, important factors such as packaging, cold start, transient response, and cost were not considered within the scope of this work. This portion of the study addresses TTW efficiencies; when combined with the WTT analysis, it will provide the full-cycle WTW efficiencies.

2.5 Acknowledgments

The authors of this report would like to thank the following people for their contributions in providing critical data for the study, reviewing the results, and providing valuable feedback and comments on the content of the report: Fritz Indra, Tim Peterson, Tony Zarger, Ken Patton, Roger Clark, Randall Yost, David Schmidt, Tanvir Ahmad, Ko Jen Wu, Roger Krieger, Arjun Tuteja, John Hepke, Peter Savagian, Dave Hilden, Norm Brinkman, Gary Herwick, Byron McCormick, Gary Stottler, Martin Fasse, Peter Kilian, Volker Formanski, Udo Winter, Matthias Bork, and Raj Choudhury. Particular recognition goes to Dr. Moshe Miller of the Advanced Development Corporation (ADC) for supporting the modeling, simulation, and analysis efforts and providing valuable consultations.

2.6 References

Allison Gas Turbine Division and General Motors Corporation, 1994, *Research and Development of Proton-Exchange-Membrane (PEM) Fuel Cell System for Transportation Applications*, U.S. Department of Energy, Contract No. DE-AC02-90CH10435.

Busshardt, J., D. Masten, M. Sinha, P. Kilian, and S. Raiser, 2000, *Dynamic Modeling and Simulation of a Fuel Cell Propulsion System*, VDI Berichte nr. 1559, 2000, presented at the 10th International Congress, Numerical Analysis and Simulation in Vehicle Engineering, Wurzburg, Germany, Sept. 14.

Fronk, M., D. Wetter, D. Masten, and A. Bosco, 2000, *PEM Fuel Cell System Solutions for Transportation*, SAE paper 2000-01-0373, Society of Automotive Engineers World Congress, Detroit, Mich., March 6.

General Motors Corporation, 1999, *Research and Development of a Proton Exchange Membrane (PEM) Fuel Cell System for Transportation Applications*, U.S. Department of Energy, Contract No. DE-AC02-90CH10435.

Rohde, S.M., and T.R. Weber, 1984, *On the Control of Vehicles with Multiple Power Sources*, Proceedings of the American Control Conference.

Skellenger, G.D., M.G. Reynolds, and L.O. Hewko, 1993, *Freedom: An Electric-Hybrid Research Vehicle Concept*, Proceedings of the International Conference on Hybrid Power Plants for Automobiles, Zurich, Switzerland, Nov.

Weber, T.R., 1998, *Analysis of Unconventional Powertrain Systems*, FISITA, Sept. 25–30.

Part 3

Well-to-Wheel Fuel/Vehicle Pathway Integration

Dr. Anthony Finizza
AJF Consulting

Dr. James P. Wallace III
Wallace & Associates

June 2001

3.1 Introduction

Part 1 of this report presented energy use and GHG emissions on a well-to-tank basis for 75 fuel pathways analyzed by Argonne National Laboratory. In many cases, Argonne found that the results for various pathways were so similar that it was possible to reduce the number of the pathways by selecting a “representative” fuel within a fuel category. This was true for multiple gasoline and diesel pathways. Argonne pared its results down to 30 representative fuel pathways. For Part 2, researchers from GM quantified the energy use of 15 advanced powertrain systems (tank-to-wheel [TTW] analysis) (see Table 2.1).

This part of the report combines the results of Parts 1 and 2 into an analysis of well-to-wheel (WTW) efficiency and GHG emissions — providing a complete view of these alternative fuel/vehicle pathways. The first part of Section 3.2 (Methodology) describes the process and criteria used to reduce the 30 representative pathways selected in Part 1 to 13 pathways. The second part (Part B) describes the process used to combine these 13 fuel pathways with the 15 vehicle pathways identified in Part 2 to obtain 27 fuel/vehicle combinations for further analysis of their WTW energy use and GHG emissions characteristics. Sections 3.3 (Results) and 3.4 (Conclusions) address the key findings of our analysis.

3.2 Methodology

3.2.1 Part A: Selection of Well-to-Tank Pathways

In addition to the 30 fuel pathways identified in the WTT portion of the study, two E85 pathways were added to facilitate analysis of the two E85-fueled vehicles analyzed in Part 2 (see Table ES-2.2). Fuel use and GHG emissions information for the two E85 pathways (corn and herbaceous) is contained in Appendix B in Volume 3 of this report series. The 32 pathways were reduced to 13 on the basis of two criteria: resource availability and energy use. Two other criteria that can be used for screening fuel/technology pathways — economic/investment issues and technological hurdles — were not considered in this study, but may be addressed in follow-on work. The two electricity fuel pathways were not considered because neither battery-powered electric vehicles nor charge-depleting hybrid electric vehicles (HEVs) were considered (for reasons outlined in Part 2).

3.2.1.1 Resource Availability

During the integration analysis, we excluded 12 of the 30 fuel pathways selected in Part 1 on the basis of resource availability — the pathways involving NA NG (eight NG- and two electrolysis-based) and corn-based ethanol.

North American NG-Based Pathways

The current and potential NA NG resource base appears to be insufficient to supply wide-scale use of NG for transportation fuels in the U.S. market.

Three recent studies suggest that rapid incremental NG demand in the United States, in particular for electricity generation, will put pressure on the NA gas supply, even without a significant transportation demand component. These studies — conducted by the Energy Information

Administration (EIA 2000) of the U.S. Department of Energy (DOE), the Gas Technology Institute (GTI) (formerly the Gas Research Institute [GRI 2000], and the National Petroleum Council (NPC 1999) — predict rapid NG demand growth in the United States, primarily to fuel incremental electricity generation and to meet growing population needs (see Table 3.1). In all three of these studies, the demand for NG grows by almost a third by the year 2010 from a base year of 1998. The primary use for this incremental demand (see Table 3.2) is gas-fired CC electricity generation. This sector alone will require 40–50% of the incremental NG demand. Industrial and residential use will also place heavy demands on the NG industry.

Table 3.1 Comparison of Studies of the U.S. Natural Gas Market^a

Parameter	Base	EIA ^b		GRI ^c		NPC ^d	
	1998	2005	2010	2005	2010	2005	2010
<i>Consumption (Total)</i>	21.8	25.2	28.1	25.7	28.6	26.3	29.0
Residential	4.6	5.3	5.5	5.1	5.4	5.6	5.8
Commercial	3.0	3.6	3.8	3.5	3.8	3.7	3.8
Industrial	8.4	8.8	9.3	9.5	10.3	9.6	10.2
Electricity generation	3.7	5.4	6.9	5.2	6.4	5.1	6.6
Transportation (vehicles)	0.0	0.1	0.1	0.1	0.3	0.0	0.0
Other ^e	2.1	2.0	2.5	2.3	2.4	2.3	2.6
<i>Supply (Total)</i>	22.0	25.4	28.8	25.7	28.6	26.3	29.0
U.S. Production	18.8	20.9	23.2	21.8	24.5	22.6	25.1
Net Imports							
Canada	3.0	4.3	4.8	3.6 ^f	3.9 ^f	3.7	3.8
Mexico	0.0	-2	-3	NE ^g	NE	0.0 ^f	0.1 ^f
LNG	0.0	0.4	0.5	0.0	0.0	NE	NE

^a Values are in trillion (10¹²) cubic feet.

^b EIA (2000).

^c GRI (2000).

^d NPC (1999).

^e Includes lease and plant fuel, pipeline fuel, etc.

^f Not broken out in source documents.

^g NE = not estimated.

Table 3.2 Incremental Increase in U.S. Natural Gas Demand in 2010 Relative to 1998 Base Year^a

Parameter	EIA	GRI	NPC
<i>Consumption (Total)</i>	6.3	6.8	7.2
Residential	0.9	0.8	1.2
Commercial	0.8	0.8	0.8
Industrial	0.9	1.9	1.8
Electricity generation	3.2	2.7	2.9
Transportation (vehicles)	0.1	0.1	0.0
Other ^b	0.4	0.3	0.5
Electricity increment (as % of total increment)	51	40	40

^a Values are in trillion (10¹²) cubic feet.

^b Includes lease and plant fuel, pipeline fuel, etc.

It is important to note that the three studies assume that the rate of electricity demand growth will be roughly the same from 1999 to 2010 as it has been in the prior 10 years (1989 to 1999) — 2.1% per year — and that it will be only slightly higher than it was from 1979 to 1989. The researchers predicated their view on the basis of the assumption that electricity use will become more efficient. If electricity demand is higher than the studies predict, it will put an even greater strain on the NG supply.

The three studies cited project only token use of NG as a transportation fuel. Even in the most optimistic GRI forecast, only 1% of NG will be used for transportation in 2010. Given the tight gas supply in the base case, it is clear that significant gas imports would be required if NG is to play a major role as a NA transportation fuel. To expand the use of NG to fuel a sizable portion of the light-duty transportation market by 2010 and beyond would require an even greater transition than the three studies envision. Table 3.3 illustrates the magnitude of the U.S. transportation market.

Can this incremental amount of NG needed for wide-scale transportation use come from North America without substantial increase in prices or improvements in technology? All three studies imply that finding the resource base to produce this incremental supply would represent a major challenge for domestic producers. The import of large pipeline volumes from Canada, beyond those already envisioned, is also not likely. Some analysts expect exploitation of NG potential on the North Slope of Alaska. These reserves of 30+ trillion cubic feet are embodied in the reserve estimates. While this volume represents a sizeable NG resource, it is earmarked for residential and electric utility use in the Midwest.

Table 3.4 shows the resource potential for NG worldwide. The data comprise reserves that have been found and are producible given today’s technology and prices (known reserves), the U.S. Geological Survey’s (USGS’s) assessment of reserves yet to be found (undiscovered reserves), and the USGS’s estimate of NG added from reserves discovered over time (reserve growth). The phenomenon of reserve or field growth, in which the initial estimates of reserves are increased as exploration and production (E&P) technology improves, accounts for a

Table 3.3 EIA Baseline Forecast of the U.S. Transportation Market^{a,b}

Fuel	1998	2005	2010	Increment 2010/1998
Motor gasoline	15.12	17.17	18.47	3.35
Diesel	4.82	6.09	6.78	1.96
LPG ^c	.02	.03	.04	.02
CNG	.01	.06	.09	.08
E85	.01	.02	.03	.02
M85 ^d	.00	.00	.00	.00
<i>Totals</i>	19.98	23.37	25.41	5.43

^a Source: EIA (2000).

^b Values were converted into trillion (10¹²) cubic feet equivalents from EIA forecasts, which are in quadrillion Btu (1 trillion cubic feet = 0.97 quadrillion Btu).

^c LPG = liquefied petroleum gas.

^d M85 = a mixture of 85% methanol and 15% gasoline (by volume).

Table 3.4 Natural Gas Resource Base^a

Region	Natural Gas (billions of barrels of oil equivalent) ^b			Oil (billions of barrels)
	Known Reserves	Undiscovered Reserves	Total Known and Undiscovered Reserves	Total Known and Undiscovered Reserves
Former Soviet Union	352	287	640	173
Middle East and North Africa	374	244	618	956
Asia-Pacific	53	68	120	69
Europe	33	56	88	41
North America	46	121	168	201
Central & South America	43	87	130	200
Sub-Saharan Africa	27	42	69	105
South Asia	12	21	34	9
World	941	926	1,867	1,754
Estimated reserve growth (done on world basis only)			652	674
Total future resources available			2,519	2,428
Other liquids (natural gas liquids [NGLs])				270

^a Sources: *Oil & Gas Journal* (2000) for known reserves; USGS (2000) for undiscovered reserves and reserve growth.

^b 1 barrel = 5.61 thousand cubic feet.

significant amount of oil and gas not currently accounted for in the undiscovered reserve and known reserve estimates.

As Figure 3.1 shows, North America accounts for only about 9% of the resource potential of NG. (The figure does not include reserve growth, but the share should not differ much from the estimate shown because the reserve growth for the United States is approximately 10% of the world reserve growth.) It is clear that the United States would have to rely on NNA gas at some point in its quest to penetrate the transportation market with wide-scale use of NG-based fuels.

It is interesting to note that North America holds a similar percentage (11%) of oil resources (see Figure 3.2). This explains, in part, the need for imported crude oil to supply the U.S. transportation sector.

Consistent with these studies, our assessment of NG resources is that high-volume, NG-based, light-duty fuel pathways would have to rely on non-North-American NG; as a result, we considered examination of NNA NG-based pathways to be far more feasible than NA NG-based pathways and dropped the latter from our analysis.

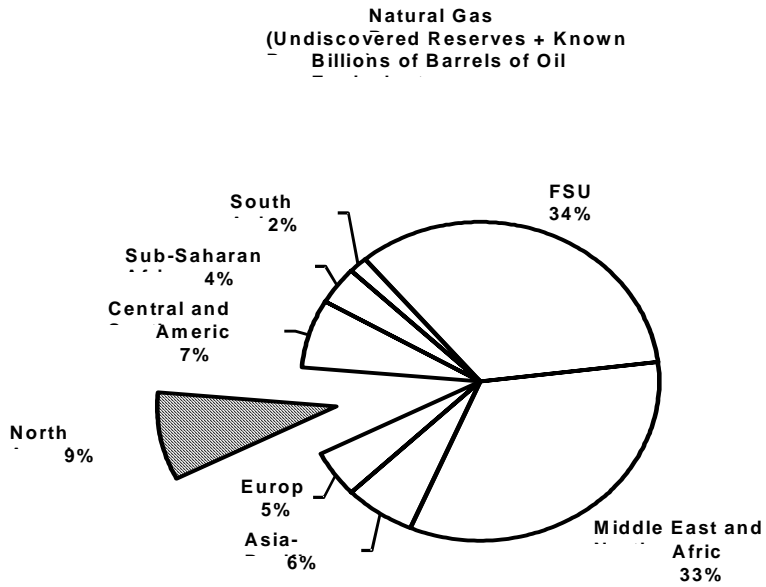

Source: USGS 2000
12/18/0

Figure 3.1 Potential Natural Gas Resources

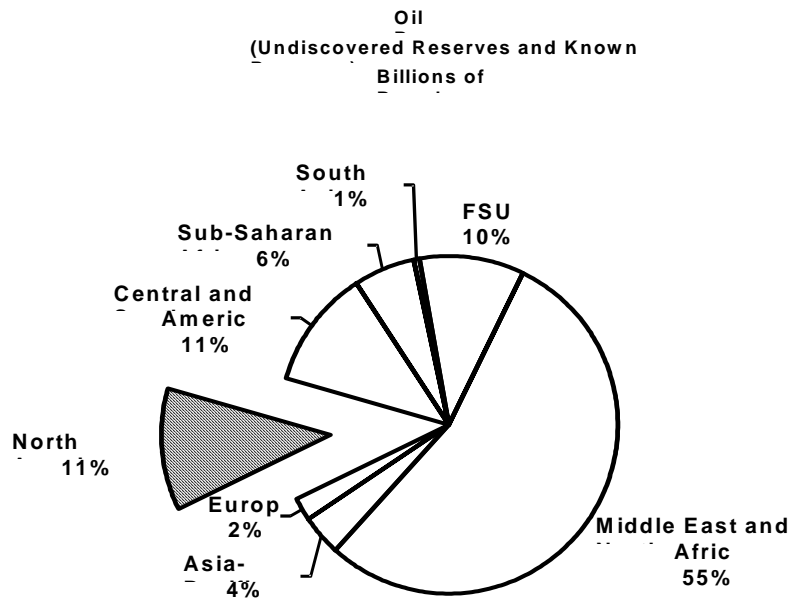

Source: USGS 2000
12/18/0

Figure 3.2 Potential Oil Resources

Corn Ethanol-Based Pathways

The current use of ethanol as a transportation fuel in the United States is about 1.5 billion gallons per year — equivalent to about 1 billion gallons of gasoline (on an energy basis). Today, the United States consumes in excess of 100 billion gallons of gasoline per year.

Recent U.S. Department of Agriculture (USDA) simulations show that production of corn-based ethanol could be doubled — to about 3 billion gallons per year — without drastic impacts on the animal feed and food markets (Price et al. 1998).

Although the production of corn ethanol could be doubled in ten years, the amount produced still would be adequate to supply only the ethanol blend market and potential use in RFG (if MTBE is going to be banned nationwide and if the RFG oxygenate requirements will be kept). It does not appear that the supply of corn-based ethanol will be adequate for use in high-volume transportation applications; as a result, we eliminated corn-based ethanol from the analysis.

The economics of cellulosic ethanol are not currently competitive with those of gasoline. Further, it has yet to be determined whether cellulosic biomass faces resource availability constraints. Also, some experts have concluded that the technology for producing biofuels will have to be significantly improved to make this pathway viable (Kheshgi et al. 2000). Because of the uncertainty here, we carried this pathway along to the WTW analysis.

3.2.1.2 Energy Efficiency

We eliminated two fuel pathways on the basis of energy inefficiency. LH₂ from NG produced at stations had significantly lower WTT efficiency than LH₂ produced at central plants. The low end of the distribution of efficiency estimates for LH₂ produced at central plants is higher than the highest value of the distribution for LH₂ produced at refueling stations — there is no overlap in the percentile range (see Table 3.5). Because the two candidate fuels are used in the same vehicle (FCVs), we eliminated the less efficient of the pair, LH₂ produced at stations.

All four electrolysis pathways presented in Part 1 would normally be excluded because they do not offer acceptable energy efficiency and GHG emissions characteristics. The WTW efficiencies for several competing NG-based vehicles are already higher than the efficiencies in the electrolysis pathways based solely upon the WTT stage (Part 1 of the study). Many proponents of electrolysis, however, point to its potential use in the transition to high-volume H₂ FCV applications. For this reason, we exclude only the less efficient of the electrolysis pathways, LH₂.

FT naphtha, a candidate reformer fuel for FCVs, is surpassed by crude naphtha on a WTT efficiency basis because both candidate fuels can be used in the same vehicle. Likewise, Fischer-Tropsch diesel (FTD) offers lower energy efficiency than crude-based diesel. However, because the FT fuels are of interest to a broad range of analysts and may have other benefits (e.g., criteria pollutants) not captured in this analysis, they have not been eliminated from consideration.

Table 3.5 Comparison of Selected Pathways

Pathway	Well-to-Tank Efficiency (%)		
	20 percentile	50 percentile	80 percentile
LH ₂ – central plants	39	41	43
LH ₂ – stations	28	32	35
GH ₂ electrolysis: U.S. mix	26	28	30
LH ₂ electrolysis: U.S. mix	21	23	25

Predicated on the screening logic described above, we pared the number of fuel pathways considered to the 13 listed in Table 3.6. These fuels, taken together with the 15 vehicles considered in Part 2, yield the 27 fuel/vehicle pathways analyzed on a WTW basis in this study.

Table 3.6 Summary of Pathways Selected for Well-to-Wheel Integration Analysis

Pathways Identified in Part 1	Excluded		Carried to Well-to-Wheel Analysis	No.
	Resource Availability	Energy Efficiency		
<i>Oil-Based</i>				
1 Current gasoline	Used as reference only.			
2 Low-sulfur gasoline			X	1
3 Current diesel	Used as reference only.			
4 Low-sulfur diesel			X	2
5 Crude naphtha			X	3
<i>Natural-Gas-Based</i>				
6 CNG: NA NG	X			
7 CNG: NNA NG			X	4
8 MeOH: NA NG	X			
9 MeOH: NNA NG			X	5
10 FT naphtha: NA NG	X			
11 FT naphtha: NNA NG			X	6
12 FTD: NA NG	X			
13 FTD: NNA NG			X	7
14 GH ₂ – central plants: NA NG	X			
15 GH ₂ – central plants: NNA NG			X	8
16 LH ₂ – central plants: NA NG	X			
17 LH ₂ – central plants: NNA NG			X	9
18 GH ₂ – stations: NA NG	X			
19 GH ₂ – stations: NNA NG			X	10
20 LH ₂ – stations: NA NG	X			
21 LH ₂ – stations: NNA NG		X		
<i>Electricity-Based</i>				
22 Electricity: U.S. mix	Discussed in Part 2			
23 Electricity: CC turbine, NA NG	Discussed in Part 2			
<i>Electrolysis-Based</i>				
24 GH ₂ electrolysis: U.S. mix			X	11
25 GH ₂ electrolysis: CC turbine, NA NG	X			
26 LH ₂ electrolysis: U.S. mix		X		
27 LH ₂ electrolysis: CC turbine, NA NG	X			
<i>Ethanol-Based</i>				
28 E100: corn	X			
29 E100: herbaceous cellulose			X	12
30 E100: woody cellulose ^a				
<i>Additional Pathways Considered</i>				
31 E85: corn	X			
32 E85: herbaceous cellulose			X	13

^a Deleted: herbaceous cellulose considered representative of cellulosic pathways.

3.2.2 Part B: Well-to-Wheel Integration

The GM WTW integration modeling process takes stochastic outputs from Parts 1 and 2 for efficiency and GHG emissions and combines them into complete WTW results (see Figure 3.3).

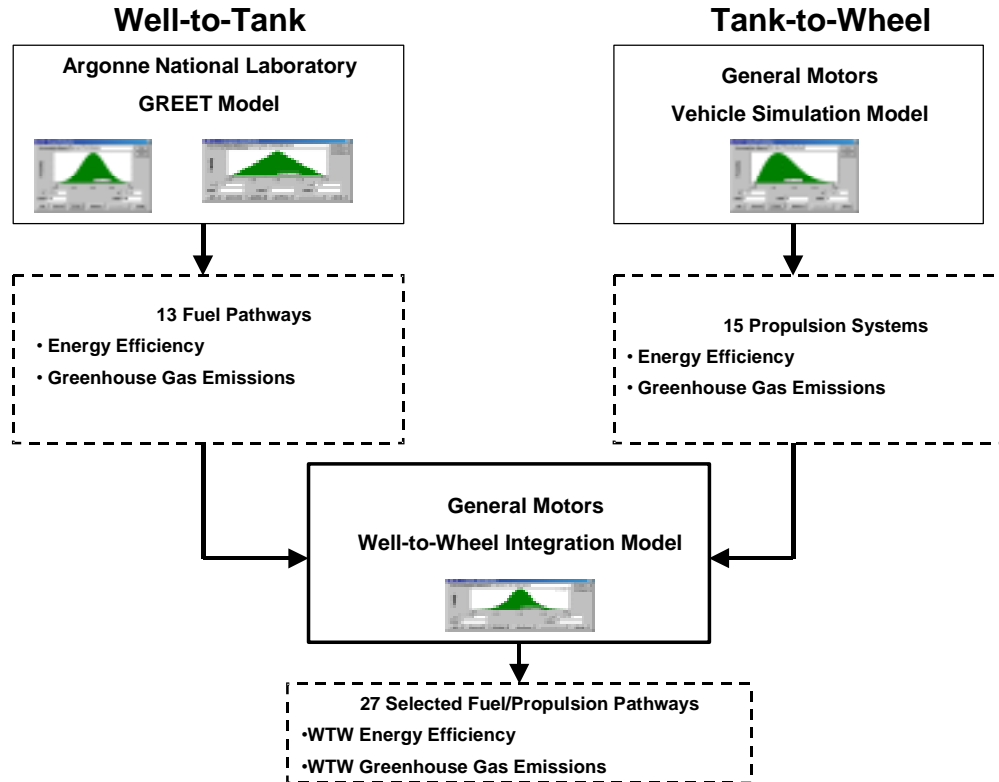

Figure 3.3 Well-to-Wheel Integration Process

3.2.2.1 Well-to-Tank (Part 1)

The GREET model results for the WTT energy use are presented as a probability distribution for energy use and GHG emissions for each fuel pathway. For the integration analysis, these results were fitted to a set of continuous distributions using well-known goodness-of-fit tests. For each of the resulting 26 distributions (energy use and GHG emissions for 13 fuels), the logistic distribution was the best-fitting distribution. The logistic distribution is asymmetric with narrower tails than the normal. The fit was performed in Crystal Ball™ among all continuous distributions available.

3.2.2.2 Tank-to-Wheel (Part 2)

Part 2 of the study provides 20, 50, and 80 percentile fuel use estimates (in mpg gasoline equivalent) for the 15 fuel/vehicle configurations selected in Part 2 (see Table 2.2). During the WTW integration process, each of these 20-50-80 percentiles was used to fit a Weibull distribution to each of the 15 fuel/vehicle configurations.

The CO₂ component of the GHGs contributed by the vehicle are related to the carbon content of the fuel because it is all combusted in the vehicle. Of course, there is no carbon in hydrogen fuels, so there is no CO₂ contribution from FCVs powered by H₂. GHGs other than CO₂ were considered negligible at the vehicle level for the other fuel/vehicle pathways.

WTW Total Energy Use Calculations

The WTW total system energy use, in Btu/mi, was computed as follows:

$$\frac{\text{Btu}}{\text{mi}} = \frac{1}{\text{WTT Eff}} \times \frac{\text{GGE}}{\text{mi}} \times \frac{112,985 \text{ Btu}}{\text{GGE}},$$

where

$$\text{WTT Eff} = \text{well-to-tank efficiency} = \frac{1,000,000}{(1,000,000 + E)},$$

GGE = gallons of gasoline equivalent, and

E = energy lost per million Btu in the WTT process.

The WTT efficiencies were computed from information provided in Part 1; the vehicle fuel consumption per mile was provided in Part 2.

WTW Greenhouse Gas Emissions Calculations

The WTW GHG emissions, in g/mi, were computed as follows:

Well-to-wheel GHG emissions = well-to-tank GHG emissions + tank-to-wheel GHG emissions,

where

$$\text{Well-to-tank GHG emissions (g/mi)} = \frac{\text{WTT GHG emissions (g)}}{\text{WTT (million Btu)}} \times \frac{\text{GGE}}{\text{mi}} \times \frac{112,985 \text{ Btu}}{\text{GGE}}$$

(the first term is provided in Part 1 and the second in Part 2) and

$$\text{Tank-to-wheel GHG emissions (g/mi)} = \frac{\text{TTW GHG emissions (g)}}{\text{TTW (million Btu)}} \times \frac{\text{GGE}}{\text{mi}} \times \frac{112,985 \text{ Btu}}{\text{GGE}}$$

(the first term is provided in Appendix 3A and the second in Part 2).

3.2.2.3 Well-to-Wheel (Part 3)

The WTT total energy use per mile for each fuel was computed on the basis of information provided in Part 1; vehicle fuel use per mile was computed from data provided in Part 2. Once the distributions from Parts 1 and 2 were developed, the joint probability distributions for WTW energy use and GHG emissions were simulated by using the Monte Carlo method. Resulting 20, 50, and 80 percentiles for both energy use and GHG emissions are shown in the figures in Section 3.3. The end points of the bars in the figures are the 80 and 20 percentile points: the 50 percentile points of the various pathways are indicated by diamonds.

3.3 Results

The analysis that follows addresses the 27 fuel/vehicle pathways listed in Table 3.7 in terms of their total system energy use (in Btu/mi) and GHG emissions (in g/mi). We evaluated SI and CIDI conventional and hybrid fuel/vehicle pathways first, followed by HEV FC vehicles, and non-hybridized FCVs. Section 3.4 provides a comparison of those pathways that appear to offer superior performance on the basis of energy use (Btu/mi) and GHG emissions (g/mi). It is very important to note that other factors (e.g., criteria pollutants, incremental fuel and vehicle costs) were not considered as part of our study.

Table 3.7 Fuel/Vehicle Pathways Analyzed

No.	Fuel Pathway	Vehicle Configuration	Fuel Abbreviation	Vehicle Abbreviation
1	Low-sulfur gasoline	Gasoline CONV SI	GASO	SI CONV
2	Low-sulfur diesel	Diesel CONV CIDI	DIESEL	CIDI CONV
3	FTD: NNA NG	Diesel CONV CIDI	FTD	CIDI CONV
4	E85: herbaceous cellulose	E85 CONV SI	HE85	SI CONV
5	CNG: NNA NG	CNG CONV SI	CNG	SI CONV
6	Low-sulfur gasoline	Gasoline SI HEV ^{a,b}	GASO	SI HEV
7	Low-sulfur diesel	Diesel CIDI HEV ^b	DIESEL	CIDI HEV
8	FTD: NNA NG	Diesel CIDI HEV ^b	FTD	CIDI HEV
9	E85: herbaceous cellulose	E85 SI HEV ^b	HE85	SI HEV
10	Low-sulfur gasoline	Gasoline FP FCV	GASO	FP FCV
11	Crude naphtha	Gasoline FP FCV	NAP	FP FCV
12	FT naphtha: NNA NG	Gasoline FP FCV	FT NAP	FP FCV
13	Low-sulfur gasoline	Gasoline FP FC HEV	GASO	FP FC HEV
14	Crude naphtha	Gasoline FP FC HEV	NAP	FP FC HEV
15	FT naphtha: NNA NG	Gasoline FP FC HEV	FT NAP	FP FC HEV
16	MeOH: NNA NG	Methanol FP FCV	MEOH	FP FCV
17	MeOH: NNA NG	Methanol FP FC HEV	MEOH	FP FC HEV
18	E100: herbaceous cellulose	Ethanol FP FCV	HE100	FP FCV
19	E100: herbaceous cellulose	Ethanol FP FC HEV	HE100	FP FC HEV
20	GH ₂ – stations: NNA NG	GH ₂ FCV	GH ₂ RS	FCV
21	GH ₂ – stations: NNA NG	GH ₂ FC HEV	GH ₂ RS	FC HEV
22	GH ₂ – central plants: NNA NG	GH ₂ FCV	GH ₂ CP	FCV
23	GH ₂ – central plants: NNA NG	GH ₂ FC HEV	GH ₂ CP	FC HEV
24	LH ₂ – central plants: NNA NG	LH ₂ FCV	LH ₂	FCV
25	LH ₂ – central plants: NNA NG	LH ₂ FC HEV	LH ₂	FC HEV
26	GH ₂ electrolysis: U.S. mix	GH ₂ FCV	GH ₂ EL	FCV
27	GH ₂ electrolysis: U.S. mix	GH ₂ FC HEV	GH ₂ EL	FC HEV

^a All HEVs are charge sustaining.

^b Parallel.

3.3.1 Conventional and Hybrid Fuel/Vehicle Pathways

Figure 3.4 shows the total system energy use (in Btu/mi) for conventional and hybrid fuel/vehicle pathways powered by SI or CIDI engines.

The figure shows that:

- The diesel CIDI HEV uses the least amount of total energy.
- The diesel CIDI conventional vehicle and the gasoline SI HEV yield roughly the same total system energy use.
- The CNG SI conventional vehicles offer no energy use benefit over gasoline conventional vehicles.
- FTD, even in a comparable technology vehicle (CONV or HEV), is more energy-intensive than crude-based diesel.
- There is considerable opportunity for energy use improvement over the 50 percentile estimates for all pathways, including the baseline gasoline SI conventional vehicle.
- Hybridizing these vehicles reduces energy use by over 15% (see Table 3.8).

Figure 3.5 shows the percent energy loss split for these fuel/vehicle combinations (the calculation for the energy loss split is provided in Appendix 3B). The figure illustrates the impacts of the energy lost in delivering CNG and, particularly, FTD to the vehicle tank. Recall that much of the WTT energy loss for HE85 is from renewable sources (see Table 3.9).

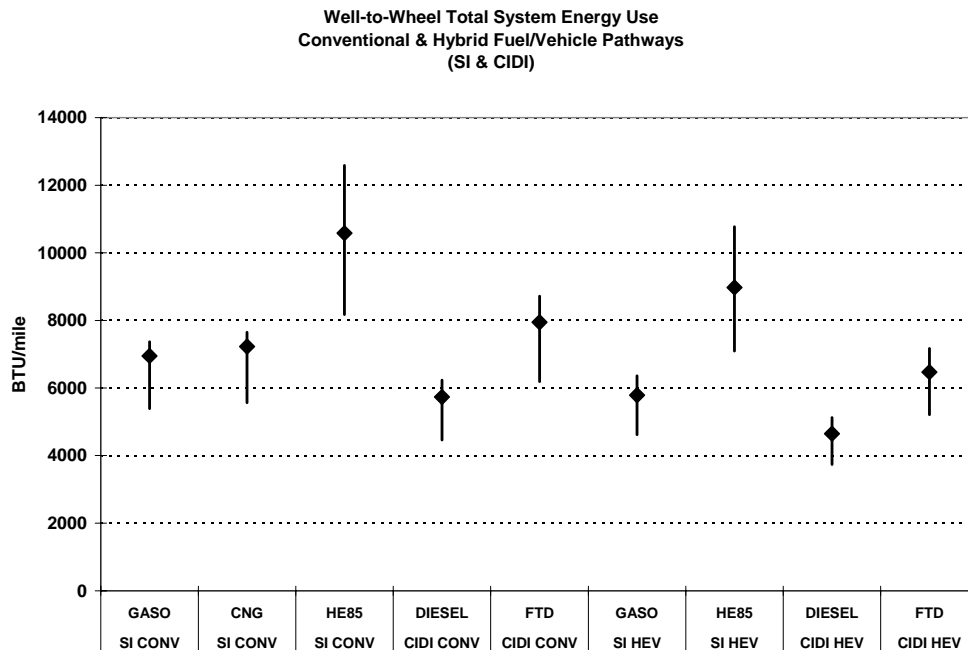

Figure 3.4 WTW Total System Energy Use: Conventional and Hybrid Fuel/Vehicle Pathways (SI and CIDI)

Table 3.8 Total WTW System Efficiency Improvements from Hybridization

Fuel	Conventional (Btu/mi) 50 percentile	HEV (Btu/mi) 50 percentile	Reduction (%)
Gasoline	6,950	5,790	17
Diesel	5,740	4,650	15
HE85	10,580	8,970	15
Average			16

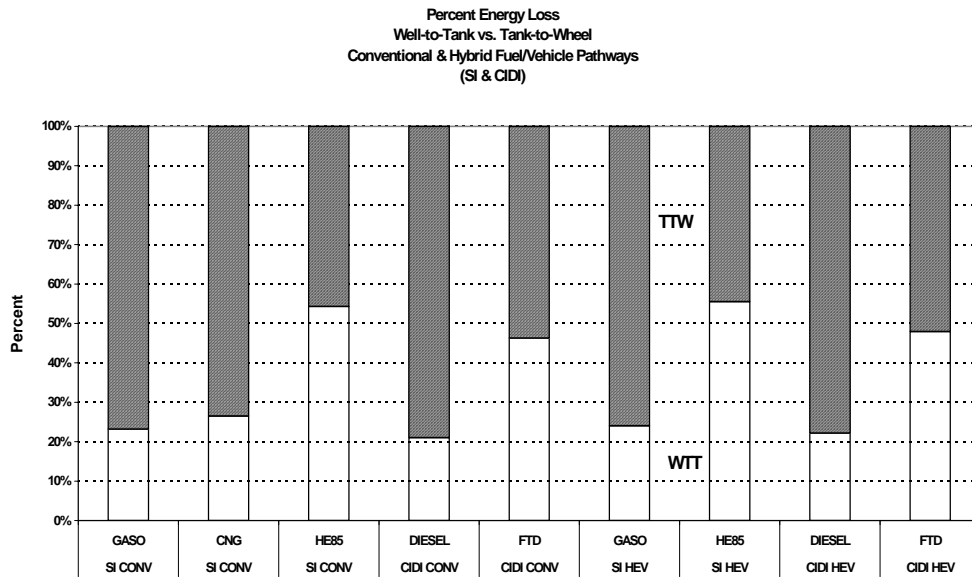

Figure 3.5 Percent Energy Loss, WTT vs. TTW: Conventional and Hybrid Fuel/Vehicle Pathways (SI and CIDI)

Table 3.9 Renewable Share of WTT Total Energy Use

Fuel	WTT % Renewable
Gasoline	1.7
Diesel	1.8
Crude naphtha	1.9
CNG	3.3
Methanol	0.2
FT naphtha	0.1
FTD	0.1
GH ₂ – central plants	3.8
LH ₂ – central plants	0.1
GH ₂ – refueling stations	2.2
GH ₂ – electrolysis	13.8
HE100	97.3
HE85	90.6

From the standpoint of GHG emissions, as shown in Figure 3.6:

- The herbaceous E85 (HE85)-fueled vehicles have by far the lowest GHG emissions.
- Among the other vehicles, the diesel CIDI HEV yields the largest potential GHG benefit.
- The CNG SI conventional vehicle generates somewhat higher GHG emissions than the diesel CIDI conventional vehicle.
- The FTD CIDI conventional vehicle and HEV have slightly higher GHG emissions than the crude oil-based diesel CIDI conventional vehicle and HEV.
- Once again, the asymmetric distributions indicate considerable opportunity for new-technology-based improvements in GHG emissions for all vehicles.

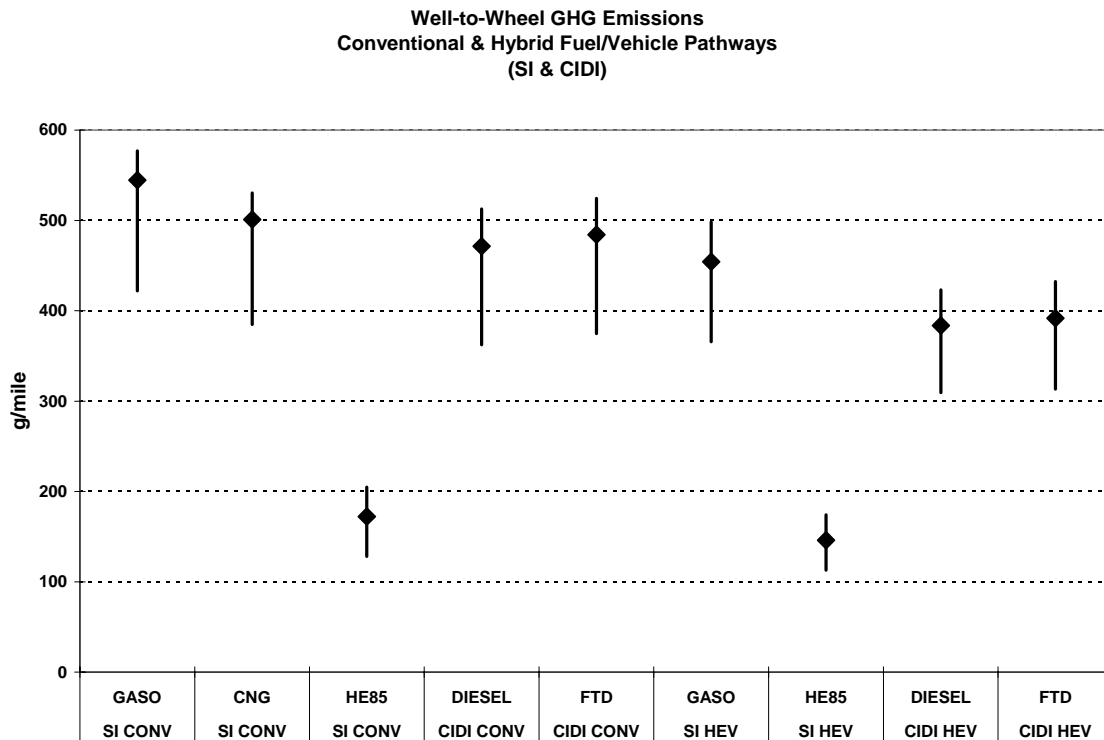

Figure 3.6 WTW GHG Emissions: Conventional and Hybrid Fuel/Vehicle Pathways (SI and CIDI)

3.3.2 Fuel/Hybrid and Non-Hybrid FCV Pathways

Nine different fuel/FCV combinations were analyzed in terms of their total system energy use and GHG emissions. Because the hybrid versions of these FCVs show an approximately 10% advantage (see Table 3.10) over their non-hybrid counterparts in terms of total systems energy use, their analysis results are discussed here.

Table 3.10 Total System Efficiency Improvements from Hybridization of FCVs

Fuel	Conventional (Btu/mi) 50 percentile	HEV (Btu/mi) 50 percentile	Reduction (%)
Gasoline	5,190	4,680	10
Crude naphtha	4,830	4,360	10
GH ₂ – central plant	5,060	4,550	10
GH ₂ – central plant	5,140	4,620	10
Methanol	5,920	5,220	12
LH ₂	6,350	5,720	10
FT naphtha	7,030	6,360	10
GH ₂ electrolysis	11,870	10,660	10
HE100	8,830	7,980	10
Average			10

As illustrated in Figure 3.7:

- Gasoline and naphtha fuel processor-based FC HEVs, as well as H₂-fueled FC HEVs for which the H₂ is produced centrally or at the retail site from non-North-American NG, all offer the best total system energy use.
- Hybridized FCVs fueled by LH₂ and FT naphtha involve higher energy consumption; MeOH use results in higher energy consumption, but is not statistically¹ different from, gasoline, crude naphtha, or GH₂.
- The electrolysis-based H₂ FC HEV uses significantly more energy than the other pathways.
- The HE100-based pathway fares poorly on total system energy use, although a significant portion of the energy used is renewable (see Table 3.9).

Figure 3.8 reveals several interesting findings:

- While the total system energy use for gasoline and naphtha FP FC HEVs is roughly comparable to that of the H₂ FC HEV (as shown in Figure 3.7), their WTT energy loss split is entirely different: 18-26% for the FP FC HEVs compared to about 60% for the H₂ FCVs.
- The negative impact of WTT energy loss is clear for methanol, LH₂, FT naphtha, and H₂ produced via electrolysis.

¹ Considering two pathways, if the 50-percentile (P₅₀) point of one pathway lies outside the 20–80 percentile (P₂₀–P₈₀) range of a second pathway, the P₅₀ points of the two pathways are deemed to be statistically different.

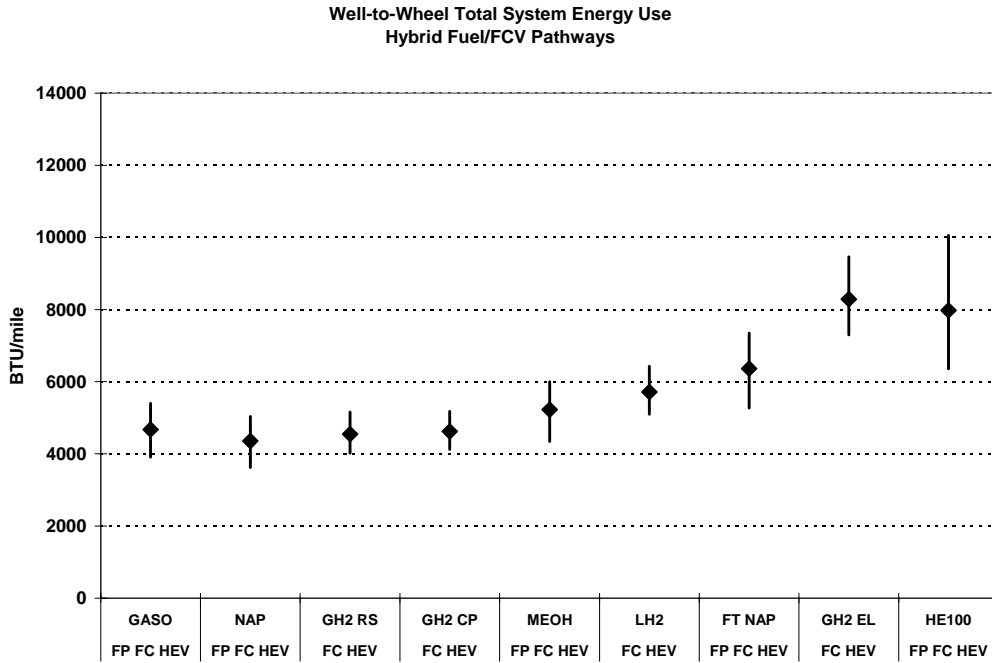

Figure 3.7 WTW Total System Energy Use: Hybrid Fuel/FCV Pathways

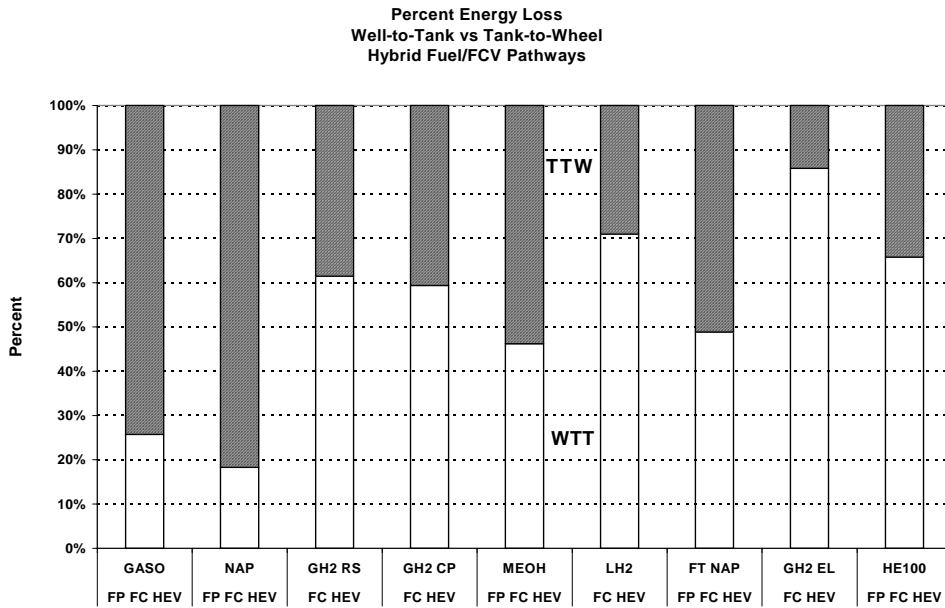

Figure 3.8 Percent Energy Loss, WTT vs. TTW: Hybrid Fuel/FCV Pathways

As shown in Figure 3.9, from a GHG standpoint, the analysis suggests:

- As expected, the HE100 FP FC HEV emits by far the lowest amount of GHGs.
- GHG emissions from the next lowest emitters, the two H₂ FC HEVs, are statistically the same.
- The naphtha and methanol FP FC HEVs are basically tied for third place.
- Gasoline FP FC HEVs and LH₂ FC HEVs are statistically tied for fourth place.
- The GH₂ electrolysis FC HEV pathways have the highest GHG emissions.

Figures 3.10 through 3.12 show non-hybridized versions of the pathways shown in Figures 3.7 through 3.9. In all cases, the energy use and GHG emissions are higher than for the corresponding hybridized FCVs. A quick review reveals that all of the rank order findings discussed above for the hybrid FCVs also apply to non-HEV versions.

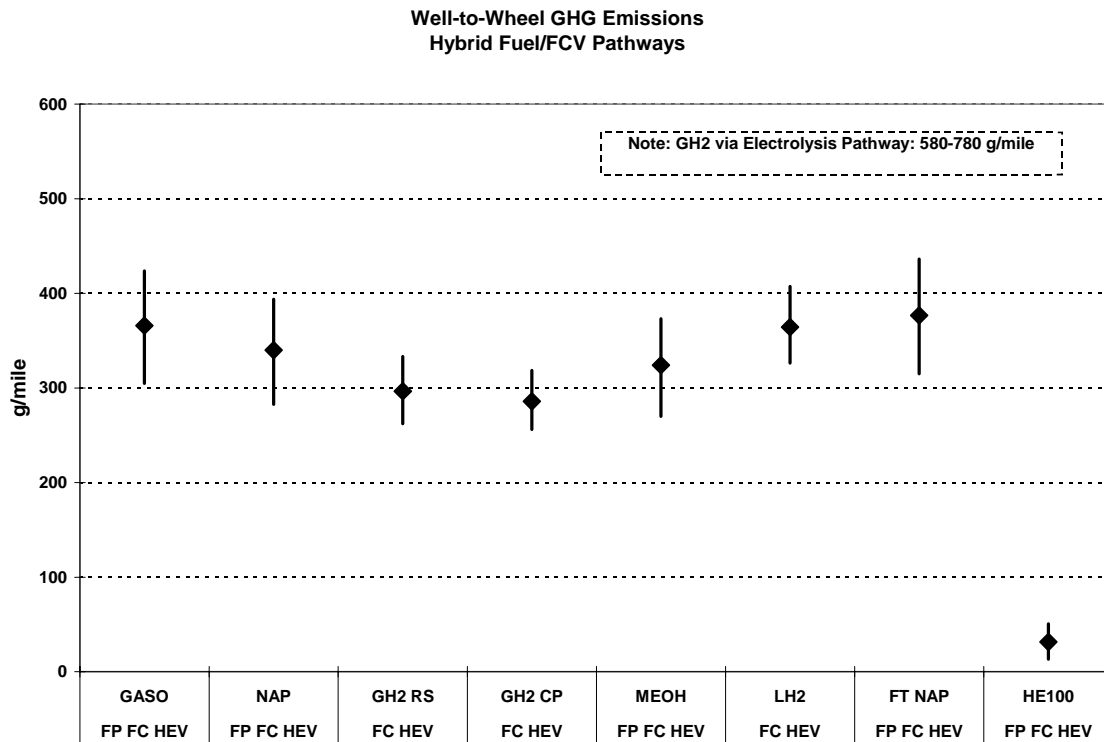

Figure 3.9 WTW GHG Emissions: Hybrid Fuel/FCV Pathways

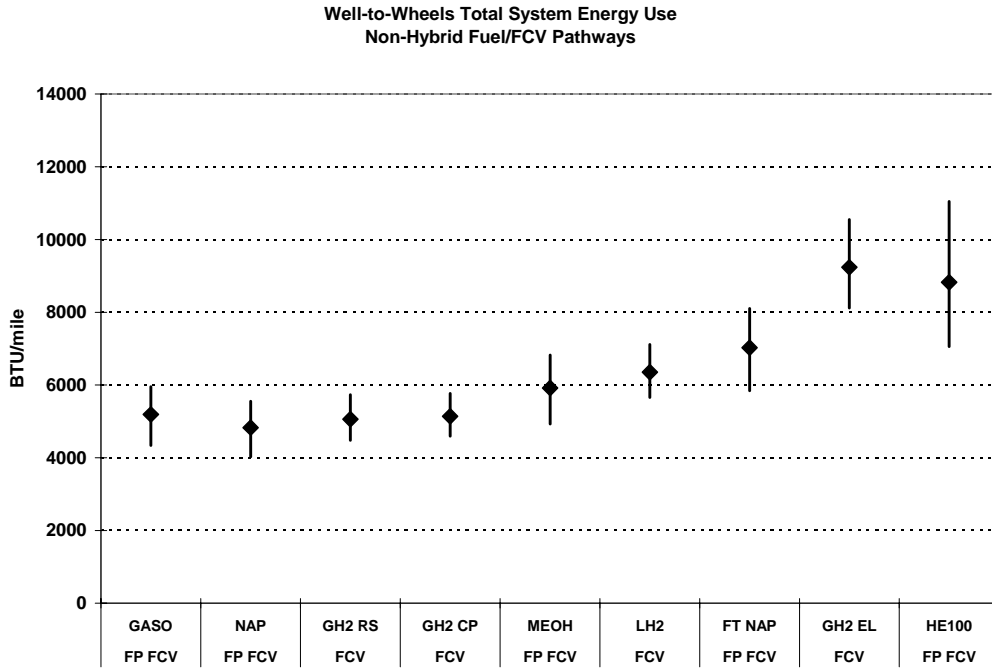

Figure 3.10 WTW Total System Energy Use: Non-Hybrid Fuel/FCV Pathways

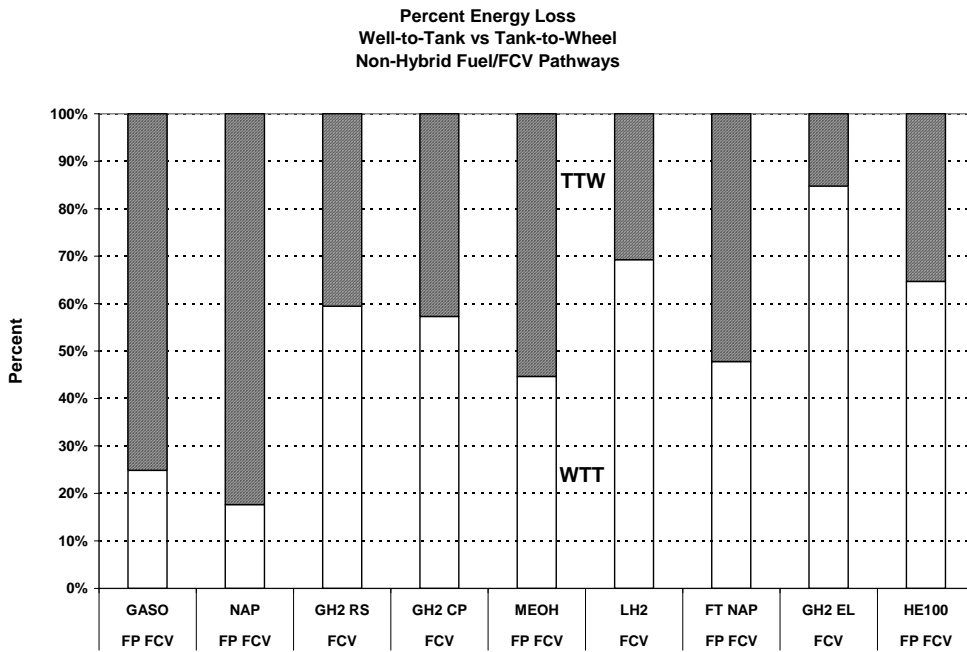

Figure 3.11 Percent Energy Loss, WTT vs. TTW: Non-Hybrid Fuel/FCV Pathways

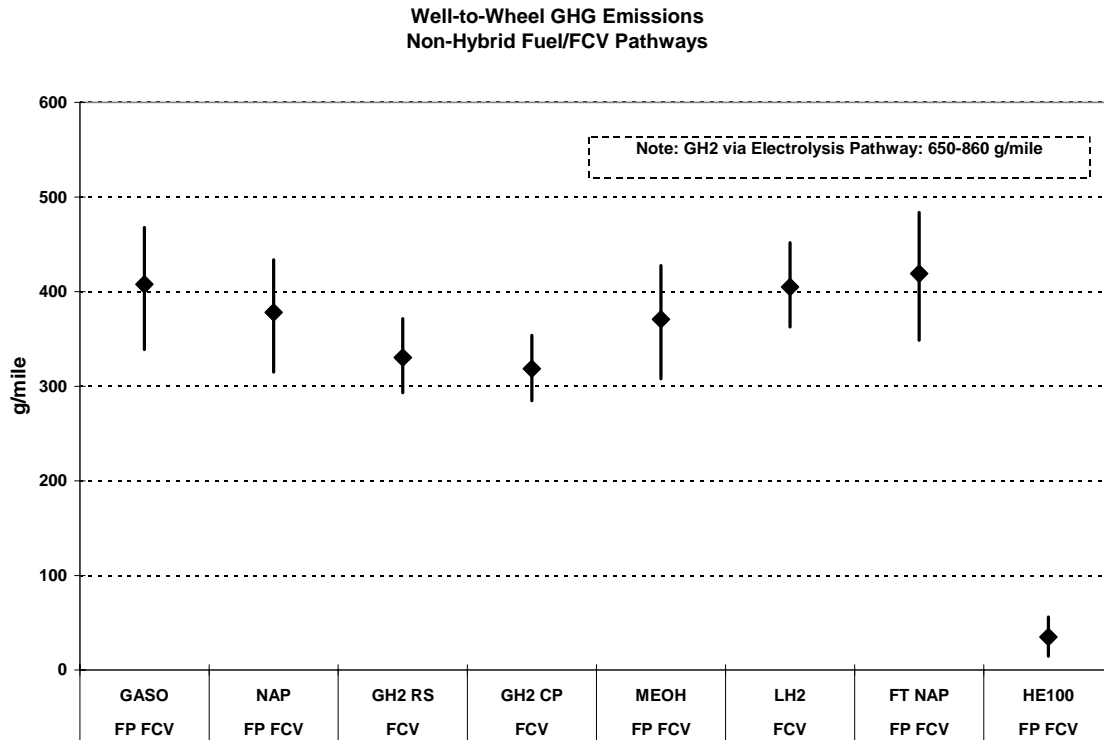

Figure 3.12 WTW GHG Emissions: Non-Hybrid Fuel/FCV Pathways

3.4 Conclusions

3.4.1 Energy Use

Key findings include the following:

- Figure 3.13 summarizes our results for total system energy use for selected pathways. From a statistical standpoint, the diesel CIDI HEV, gasoline and naphtha FP FC HEVs, as well as the two H₂ FC HEVs (represented by the GH₂ [refueling station] FC HEV only in the figures) are all the lowest energy-consuming pathways.
- Figure 3.14 illustrates an interesting finding: all of the crude oil-based selected pathways have WTT energy loss shares of roughly 25% or less. The H₂ FC HEV share is over 60%; the MeOH FP FC HEV share is about 50%. A significant fraction of the WTT energy use of ethanol is renewable — over 90% for HE100.

3.4.2 Greenhouse Gas Emissions

Key GHG findings are summarized in Figure 3.15 and include the following:

- The ethanol-fueled vehicles, as expected, yield the lowest GHG emissions per mile.
- The next lowest are the two H₂ FC HEVs (represented by the GH₂ [refueling station] FC HEV in the figure).

- The H₂ FC HEVs are followed by the MeOH, naphtha, and gasoline FP HEVs and the diesel CIDI HEV, in that order.
- The diesel CIDI HEV offers a significant reduction in GHG emissions (27%) relative to the gasoline conventional SI vehicle.

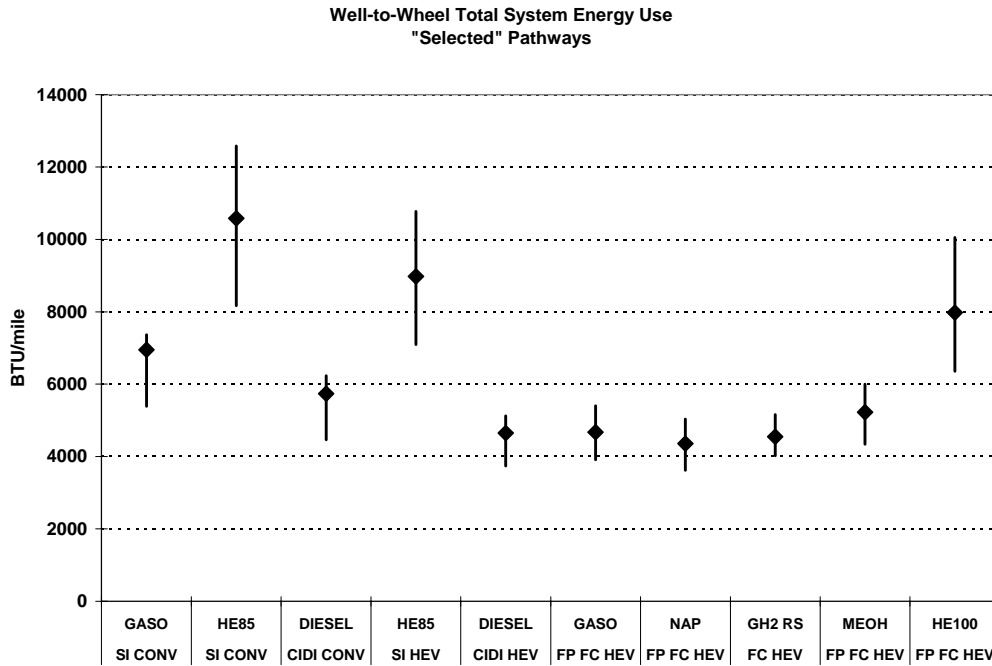

Figure 3.13 WTW Total System Energy Use: "Selected" Fuel/Vehicle Pathways

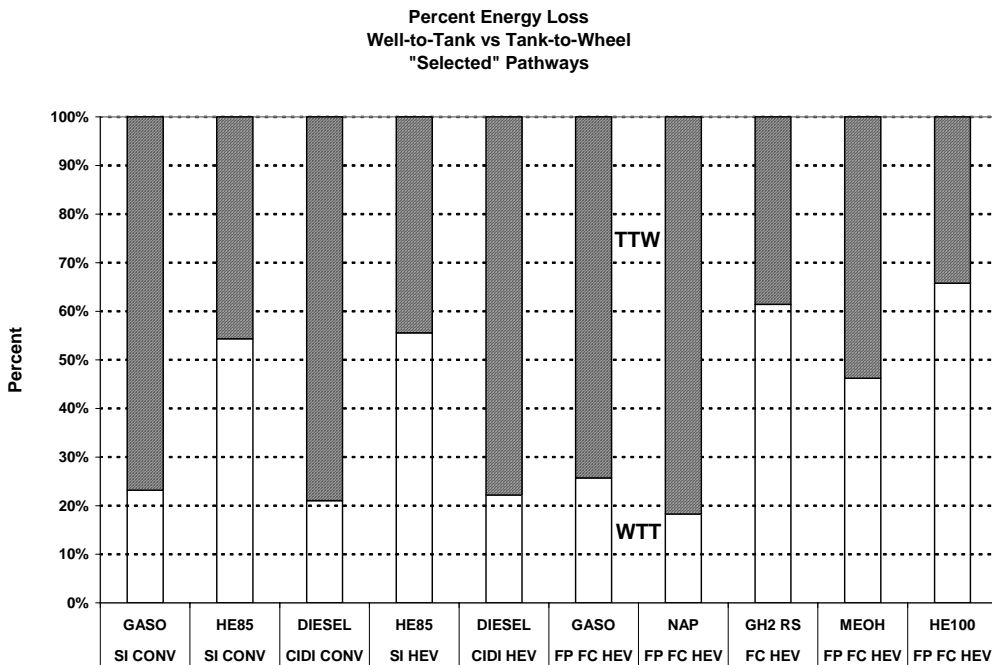

Figure 3.14 Percent Energy Loss, WTT vs. TTW: "Selected" Fuel/Vehicle Pathways

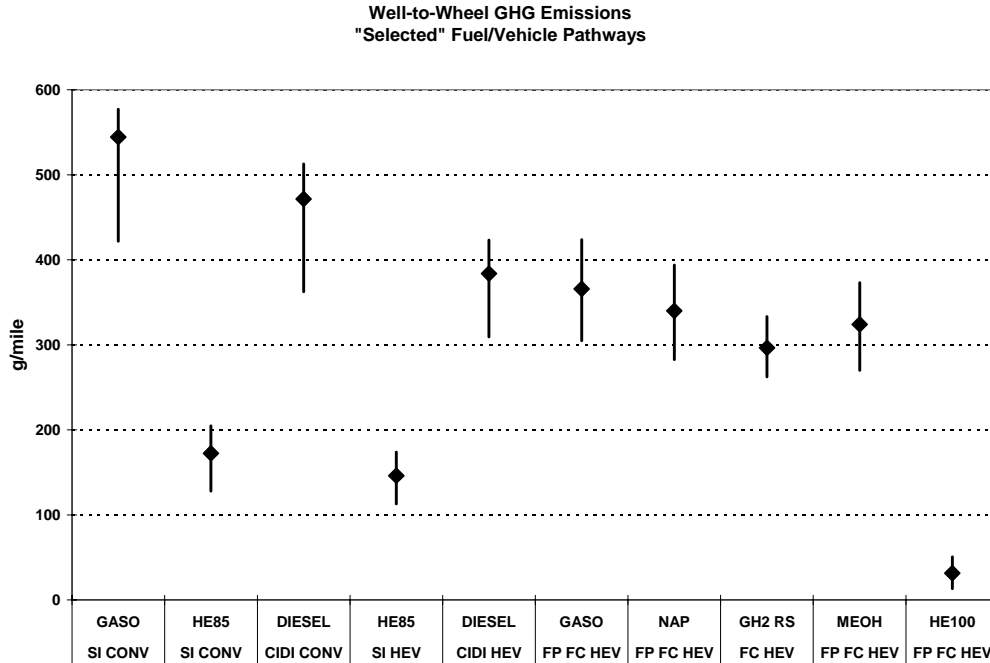

Figure 3.15 WTW GHG Emissions: "Selected" Fuel/Vehicle Pathways

3.4.3 Integrated Energy Use/GHG Emissions Results

Considering both total energy use and GHG emissions, the key findings are as follows:

- Among all of the crude oil- and NG-based pathways studied, the diesel CIDI HEV, gasoline and naphtha FP FC HEVs, and GH₂ FC HEVs, were nearly identical and best in terms of total system energy use (Btu/mi). Among these pathways, however, expected GHG emissions were lowest for the H₂ FC HEV and highest for the diesel CIDI HEV.
- Compared to the gasoline SI (conventional), the gasoline SI and diesel CIDI HEVs, as well as the diesel CIDI (conventional) yield significant total system energy use and GHG emission benefits.
- The MeOH FP FC HEV offers no significant energy use or emissions reduction advantages over the crude oil-based or other NG-based FC HEV pathways.
- Ethanol-based fuel/vehicle pathways have by far the lowest GHG emissions of the pathways studied and also do very well on WTT energy loss when only fossil fuel consumption is considered.
- It must be noted that for the HE100 FP FC HEV pathway to reach commercialization, major technology breakthroughs are required for both the fuel and the vehicle.
- On a total system basis, the energy use (Btu/mi) and GHG emissions of CNG conventional and gasoline SI conventional pathways are nearly identical.

- The crude oil-based diesel vehicle pathways offer slightly lower total system GHG emissions and considerably better total system energy use than the NG-based FTD CIDI vehicle pathways. (Note that criteria pollutants are not considered here.)
- LH₂, FT naphtha, and electrolysis-based H₂ FC HEVs have significantly higher total system energy use and the same or higher levels of GHG emissions than the gasoline and crude naphtha FP FC HEVs and the GH₂ FC HEVs.

Appendix 3C provides the data used to prepare Figures 3.4 through 3.15.

3.5 References

EIA, 2000, *Annual Energy Outlook 2001*, U.S. Department of Energy, Energy Information Administration, Dec. (www.eia.doe.gov/oiaf/aeo/).

GRI, 2000, *Pressbook – GRI Baseline Projection – 2000 Edition*, Gas Research Institute, Des Plaines, Ill.

Kheshgi, H., R. Prince, and G. Marland, 2000, “The Potential of Biomass Fuels in the Context of Global Climate Change: Focus on Transportation Fuels,” *Annual Review of Energy and Environment 2000*, 25:199–244.

NPC, 1999, *Natural Gas: Meeting the Challenges of the Nation’s Growing Natural Gas Demand*, National Petroleum Council, Dec.

Oil & Gas Journal, 2000, “Worldwide Look at Reserves and Production,” Volume 98, No. 51, pp. 122–123, Dec. 18.

Price, M., P. Westcott, P. Riley, and M. Graboski, 1998, *The Impact of Increased Corn Demand for Ethanol on Planted Cropland*, U.S. Department of Agriculture, Office of Energy Policy and New Uses, Washington, D.C., March.

USGS, 2000, *World Petroleum Assessment 2000 – Description and Results*, CD-ROM, U.S. Geological Survey.

Appendix 3A: CO₂ Content of Fuels

Fuel	CO ₂ Content (g/mmBtu)
GASO	76,477
DIESEL	81,245
FTD	78,155
CNG	60,185
HE85	76,289
NAP	76,108
FT NAP	73,959
MeOH	73,002
HE100	76,218
GH ₂	0
LH ₂	0

Appendix 3B: Energy Loss Split Calculation

Background

Background

Using the notation in Part 2, efficiency is defined as:

$$\text{Eff} = \frac{\text{EnergyOutput}}{\text{EnergyInput}} = \frac{E_o}{E_I}$$

where

$$E_o = \sum (\text{Roll Resist} + \text{Aero Resist} + \text{Ma}) * V * \Delta t \text{ over the drive cycle and}$$

E_I = energy value of fuel consumed.

To illustrate the ramifications of the above definition, assume the mass is (roughly) constant over all vehicles being compared. Then,

$$E_o = \text{constant for all vehicles} \equiv \bar{E}_o.$$

We could say that all vehicles are required to provide the same amount of “useful work,” \bar{E}_o .

Then, the energy balance requires:

$$E_{iI} = \text{energy loss in propulsion system } i \text{ (PSL}_i\text{)} + \text{Energy loss with Auxiliaries } i \text{ (AuxL}_i\text{)} + \bar{E}_o,$$

where i = propulsion system designator.

Hence,

$$\text{Eff}_i = \frac{\bar{E}_o}{\bar{E}_o + \text{PSL}_i + \text{AuxL}_i}$$

where $0 \leq \text{Eff} \leq 1$.

Our study focuses on the fuels and propulsion systems and thus on differences in PSL_i . Improvement potentials in rolling resistance, aero resistance, and lighter weight materials are not part of this study.

For each of the fuel/vehicle pathways, total Btu consumed in permitting each of the vehicles the ability to transverse the same duty cycle “miles” plus the energy consumed to provide the Btu to the vehicle necessary to transverse that duty cycle mile is known. That is, the total Btu lost (E_L) is known and is defined as:

$$E_L = E_F + E_V,$$

where

E_V = Btu lost/consumed by the vehicle to provide the duty cycle miles of mobility ($E_V = E_i$ above) and

E_F = Btu lost/consumed in the fuel production process to provide to the vehicle's tank the fuel consumed by the vehicle.

Problem

Determine the allocation of the total Btu lost (E_L) between the fuel production/delivery process (E_F) and the vehicle (E_V); that is, determine E_F/E_L and E_V/E_L , where the sum of the two allocations equals 1.

Solution

Let

E = total energy (Btu) at the "wellhead,"

e_F = efficiency of fuel production/distribution process so that

$E_F = (1 - e_F) E$, and let

e_V = efficiency of the vehicle over the duty cycle miles ($e_V = \text{Eff}_i$ above) so that

$$(1 - e_V) = \frac{(\text{Btu lost / consumed by vehicle})}{(\text{Btu provided to the vehicle})} .$$

Hence, the total system energy loss,

$$E_L = (1 - e_F) E + (1 - e_V) e_F E ,$$

from which it follows that total system efficiency,

$$\eta = \frac{(E - E_L)}{E} = e_F * e_V ,$$

and the fuel production/distribution and vehicle allocations are as follows:

$$\text{Fuel loss fraction (FLF)} = E_F/E_L = \frac{(1 - e_F)}{(1 - e_F e_V)}$$

$$\text{Vehicle loss function (VLF)} = E_V/E_L = \frac{e_F(1 - e_V)}{(1 - e_F e_V)}$$

where $\text{FLF} + \text{VLF} = 1$.

Note

This result yields η , FLF, VLF to be independent of E. In fact, E would have to vary across pathways so that the vehicles associated with all pathways can traverse the same duty-cycle miles.

Sample Calculations

e_F	e_V	FLF	VLF
0.4	0.2	0.652	0.348
0.4	0.3	0.682	0.318
0.4	0.4	0.714	0.286
0.8	0.2	0.238	0.762
0.8	0.3	0.263	0.737
0.8	0.4	0.294	0.706

Appendix 3C: Data Used to Prepare Figures 3.4 through 3.15

		WTW Energy Use			Energy Use Share		GHG Emissions		
		BTU/mile					g/mile		
		20%	50%	80%	WTT	TTW	20%	50%	80%
SI CONV	GASO	5388	6949	7365	23%	77%	422	544	577
CIDI CONV	DIESEL	4462	5735	6232	21%	79%	362	472	513
CIDI CONV	FTD	6191	7945	8718	46%	54%	375	484	524
SI CONV	CNG	5566	7224	7644	27%	73%	385	501	530
SI CONV	HE85	8170	10579	12582	54%	46%	128	172	205
SI HEV	GASO	4617	5788	6362	24%	76%	366	454	498
CIDI HEV	DIESEL	3741	4650	5126	22%	78%	309	384	423
CIDI HEV	FTD	5209	6471	7169	48%	52%	313	392	432
SI HEV	HE85	7097	8974	10771	56%	44%	113	146	174
FP FCV	GASO	4339	5192	5953	25%	75%	339	408	468
FP FCV	NAP	4025	4828	5549	18%	82%	315	378	434
FP FCV	FT NAP	5842	7026	8105	48%	52%	349	419	484
FP FC HEV	GASO	3912	4675	5398	26%	74%	305	366	424
FP FC HEV	NAP	3621	4357	5035	18%	82%	283	340	394
FP FC HEV	FT NAP	5272	6362	7346	49%	51%	315	377	436
FP FCV	MEOH	4927	5919	6827	45%	55%	308	371	428
FP FC HEV	MEOH	4341	5224	5997	46%	54%	270	324	373
FP FCV	HE100	7053	8827	11044	65%	35%	15	35	56
FP FC HEV	HE100	6358	7979	10052	66%	34%	13	31	51
FCV	GH2 RS	4476	5060	5729	59%	41%	293	330	371
FC HEV	GH2 RS	4022	4549	5159	61%	39%	262	296	333
FCV	GH2 CP	4595	5140	5765	57%	43%	285	318	354
FC HEV	GH2 CP	4122	4625	5178	59%	41%	256	286	319
FCV	LH2	5655	6351	7115	69%	31%	363	405	452
FC HEV	LH2	5101	5718	6427	71%	29%	326	364	407
FCV	GH2 EL	8117	9238	10549	85%	15%	651	750	863
FC HEV	GH2 EL	7294	8289	9463	86%	14%	584	675	777

