

Patent Prosecution Highway Pilot Program between the United States Patent and Trademark Office and the German Patent and Trade Mark Office

I. Background

The United States Patent and Trademark Office (USPTO) has established a 21st Century Strategic Plan to transform the USPTO into a more quality-focused, highly productive, responsive organization supporting a market-driven intellectual property system. One of the specific action items of the 21st Century Strategic Plan is to share search results with other intellectual property offices. By relying on the search results obtained via partnerships with other intellectual property offices, the USPTO can reduce duplication of efforts and decrease workload.

From July 2006 to January 2008, the USPTO partnered with the Japan Patent Office (JPO) to establish the first Patent Prosecution Highway pilot program (PPH). The PPH leverages accelerated examination procedures already available in both offices to allow applicants in both offices to obtain corresponding patents faster and more efficiently. The PPH also permits each office to benefit from the work previously done by the other office, in turn helping to reduce workload and improve patent quality. The USPTO and the JPO began full implementation of the PPH program on January 4, 2008.

The USPTO commenced a PPH pilot program with the Korean Intellectual Property Office (KIPO) on January 28, 2008. The pilot program ended on January 28, 2009, and full implementation of the PPH program began on January 29, 2009.

USPTO has also commenced separate PPH pilot programs with the United Kingdom Intellectual Property Office (UK IPO), the Canadian Intellectual Property Office (CIPO), IP Australia (IPAU), the European Patent Office (EPO), the Danish Patent and Trademark Office (DKPTO), and the Intellectual Property Office of Singapore (IPOS), based on the same or similar framework as the PPH between the USPTO and JPO.

Following on these partnerships, the USPTO and the German Patent and Trade Mark Office (DPMA) have agreed to launch a PPH pilot program similar to the PPH pilot programs noted above.

II. Patent Prosecution Highway Pilot Program

The PPH was established to enable an applicant whose claims are determined to be allowable/patentable in the Office of first filing (OFF) to have the corresponding application filed in the Office of second filing (OSF) advanced out of turn for examination while at the same time allowing the OSF to exploit the search and examination results of the OFF.

Where the USPTO is the OFF and the U.S. application contains claims that are determined to be allowable/patentable, the applicant may request accelerated examination

at DPMA for the corresponding application filed with DPMA as the OSF. The procedures and requirements for filing a request with DPMA for participation in the PPH pilot program will be available on April 27, 2009, from the DPMA Web site at: <http://www.dpma.de/english/patent/forms/index.html>.

Where the USPTO is the OSF and the corresponding application filed with DPMA as the OFF contains claims that are determined to be allowable/patentable, the applicant may request participation in the PPH pilot program in the USPTO and petition to make the U.S. application special under the PPH pilot program. Note that the procedures for a petition to make special under the accelerated examination program set forth in MPEP 708.02(a) do NOT apply to a petition to make special under the PPH pilot program. The procedures and requirements for filing a request in the USPTO for participation in the PPH pilot program are set forth below.

A. Trial Period for the PPH Pilot Program

The PPH pilot program will commence on April 27, 2009, for a period of two years ending on April 27, 2011. The trial period may be extended if necessary to adequately assess the feasibility of the PPH program. The USPTO and DPMA will evaluate the results of the pilot program to determine whether and how the program should be fully implemented after the trial period. The Offices may also terminate the PPH pilot program early if the volume of participation exceeds manageable level, or for any other reason. Notice will be published if the PPH pilot program will be terminated before the April 27, 2011 date.

B. Requirements for Requesting Participation in the PPH Pilot Program in the USPTO

In order to be eligible to participate in the PPH pilot program, the following conditions must be met:

(1) The U.S. application is

- (a) a Paris Convention application which either
 - (i) validly claims priority under 35 U.S.C. 119(a) and 37 CFR 1.55 to one or more applications filed with DPMA, or
 - (ii) validly claims priority under 35 U.S.C. 119(a)/365(a) to a PCT application that contains no priority claims,

or

- (b) a national stage application under the PCT (an application which entered the national stage in the U.S. from a PCT international application after compliance with 35 U.S.C. 371), which PCT application
 - (i) validly claims priority under 35 U.S.C. 365(b) to an application filed with DPMA, or

- (ii) validly claims priority under 35 U.S.C. 365(b) to a PCT application that contains no priority claims, or
- (iii) contains no priority claim,

or

- (c) a so-called bypass application filed under 35 U.S.C. 111(a) which validly claims benefit under 35 U.S.C. 120 to a PCT application, which PCT application
 - (i) validly claims priority under 35 U.S.C. 365(b) to an application filed with DPMA, or
 - (ii) validly claims priority under 35 U.S.C. 365(b) to a PCT application that contains no priority claims, or
 - (iii) contains no priority claim.

Examples of U.S. applications that fall under requirement (1) are:

(1)(a)(i):

- US application with single Paris Convention priority claim to a German (DPMA) application

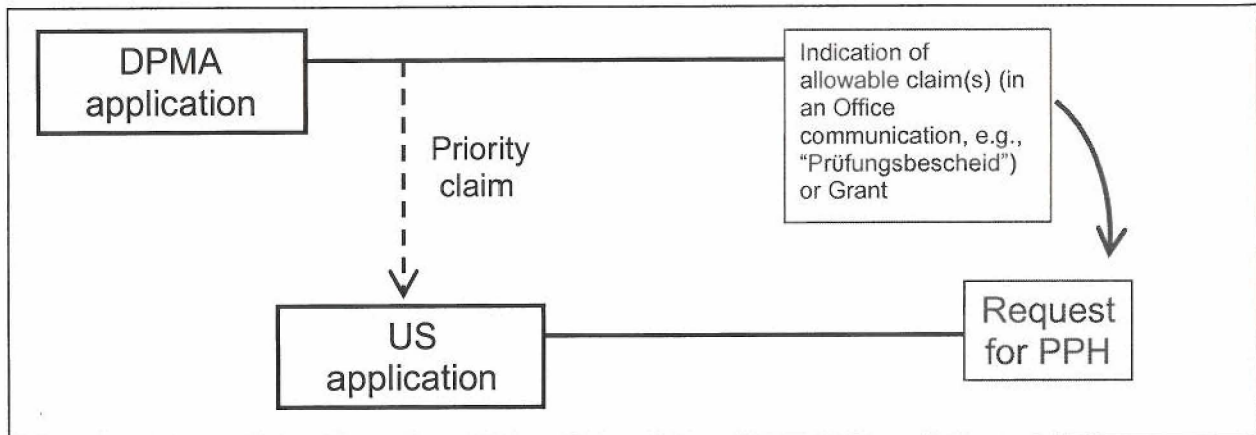

- US application with multiple Paris Convention priority claims to DPMA applications

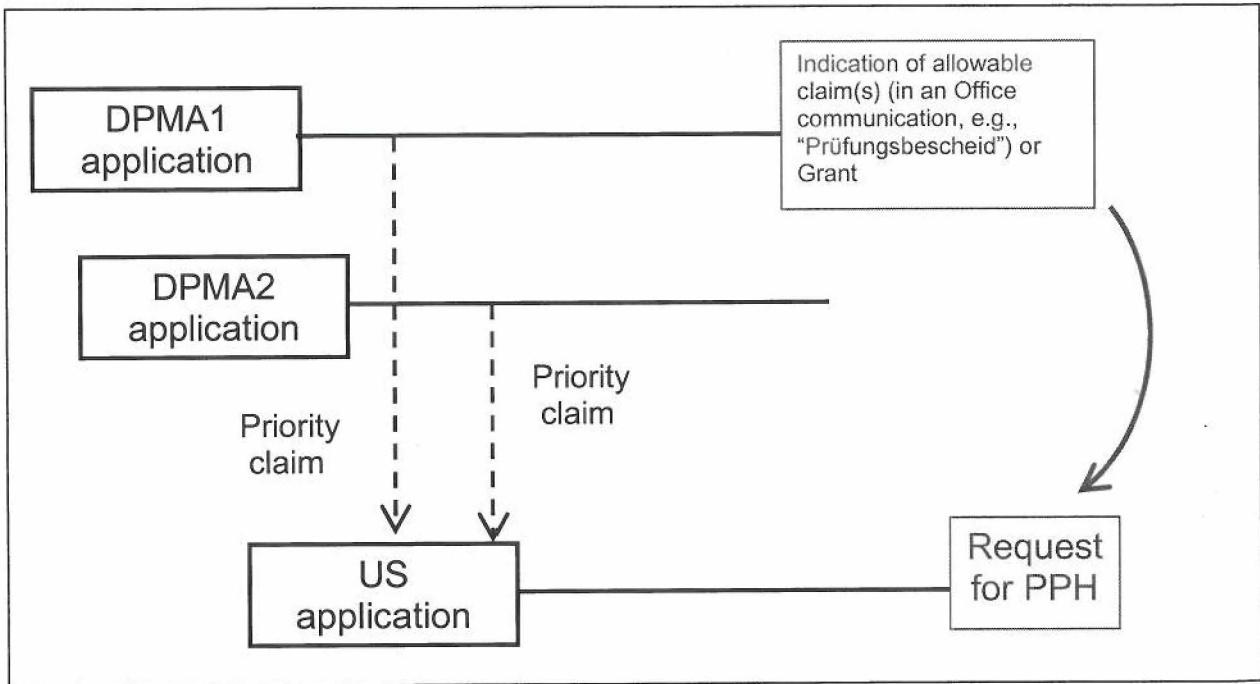

- Paris route and domestic priority

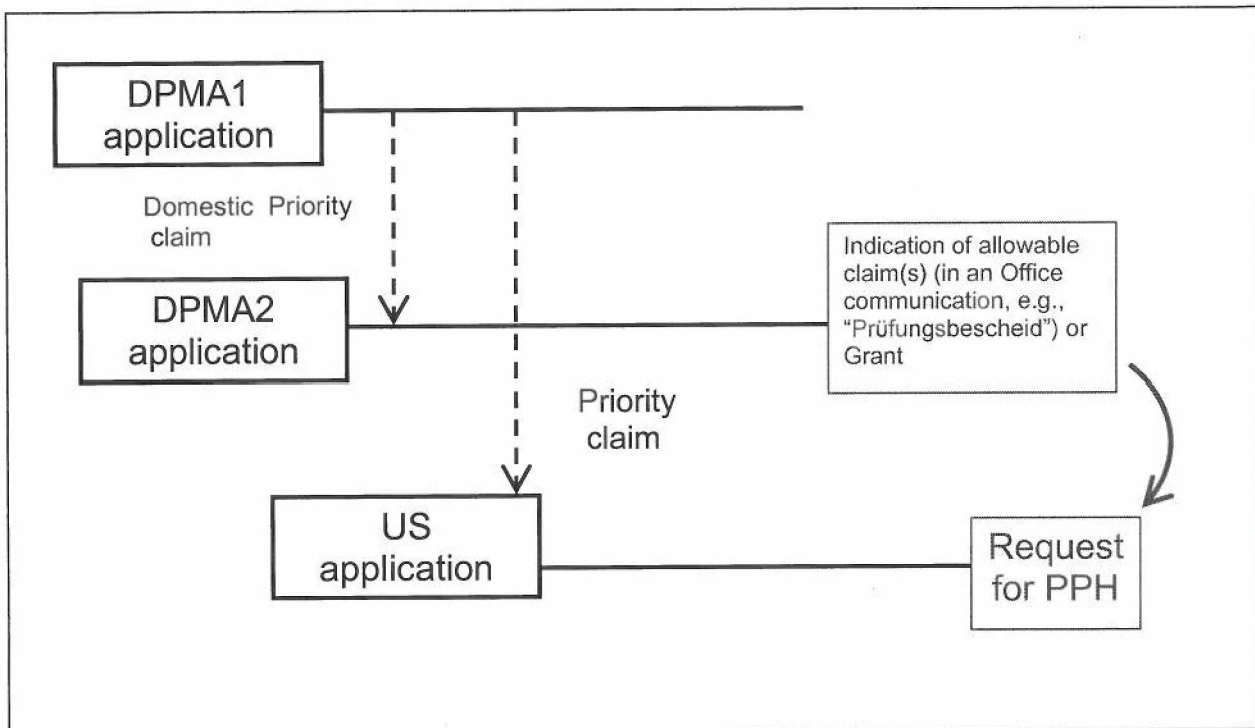

- Paris route and divisional application

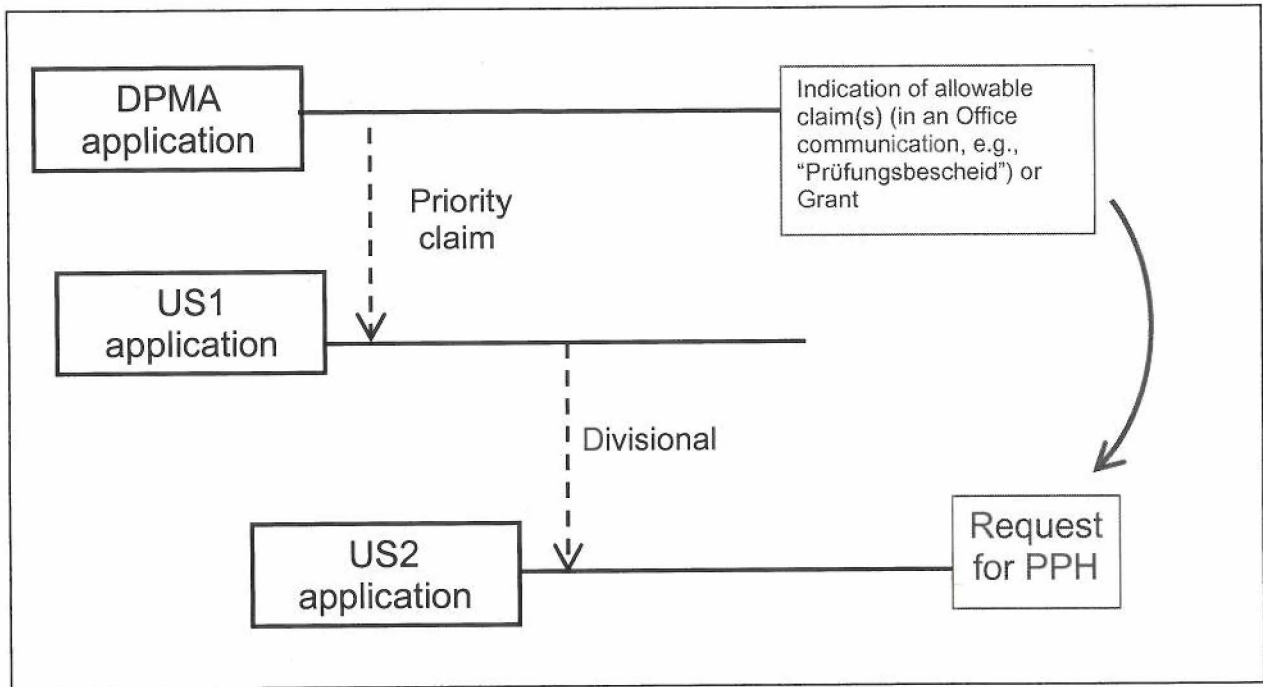

(1)(a)(ii):

- US application claims Paris Convention priority to a PCT application

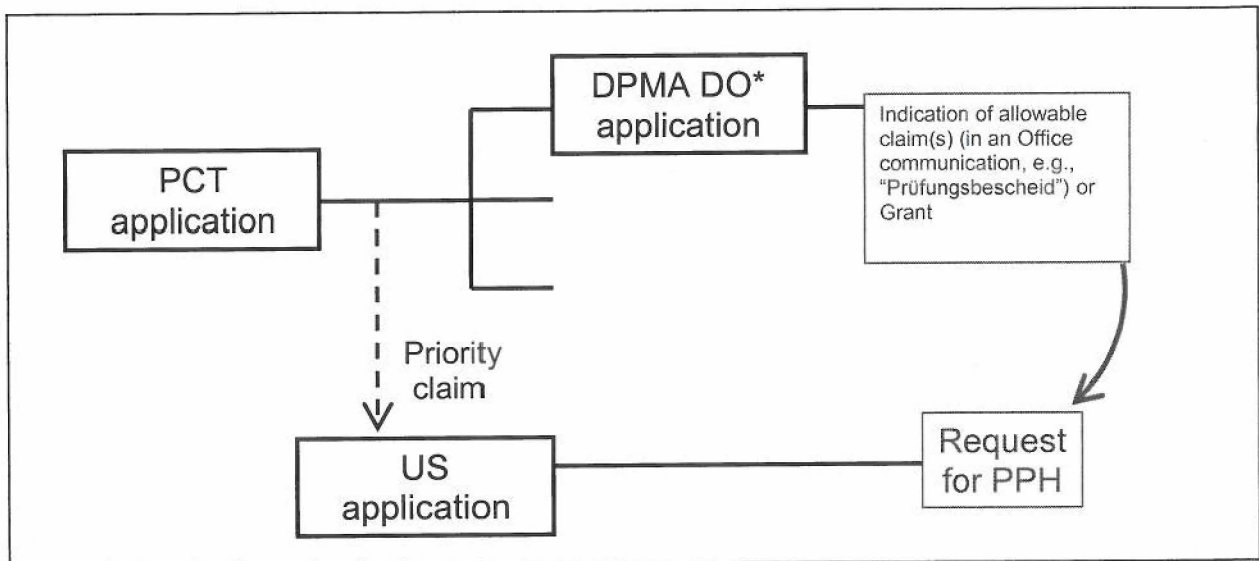

* DO – Designated Office

(1)(b)(i):

- US application is a national stage of a PCT application which claims Paris Convention priority to a DPMA application

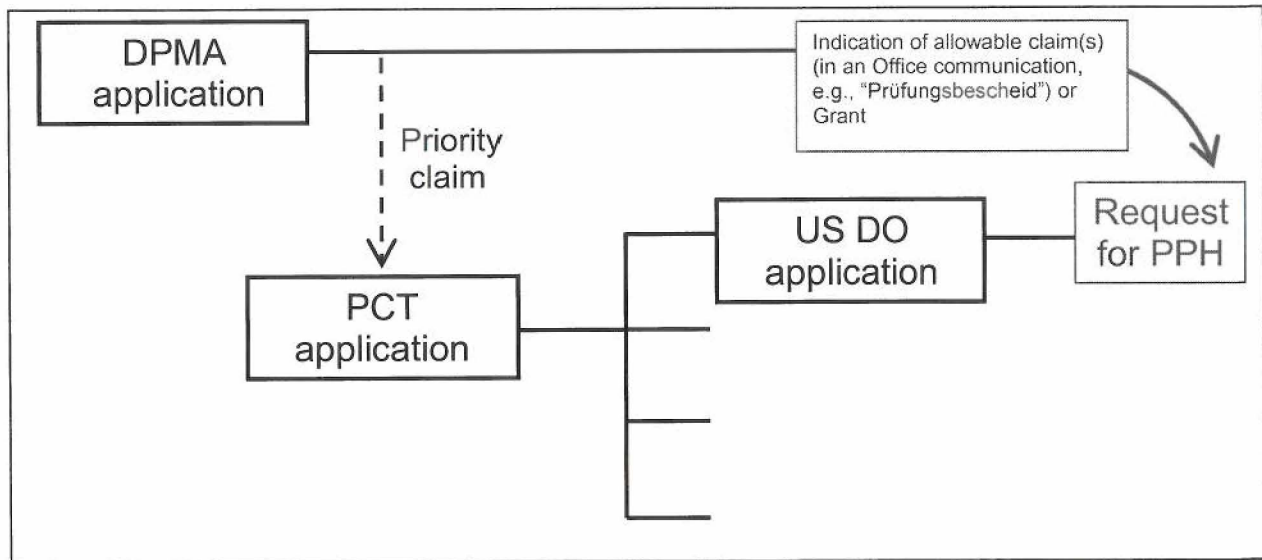

- PCT Route

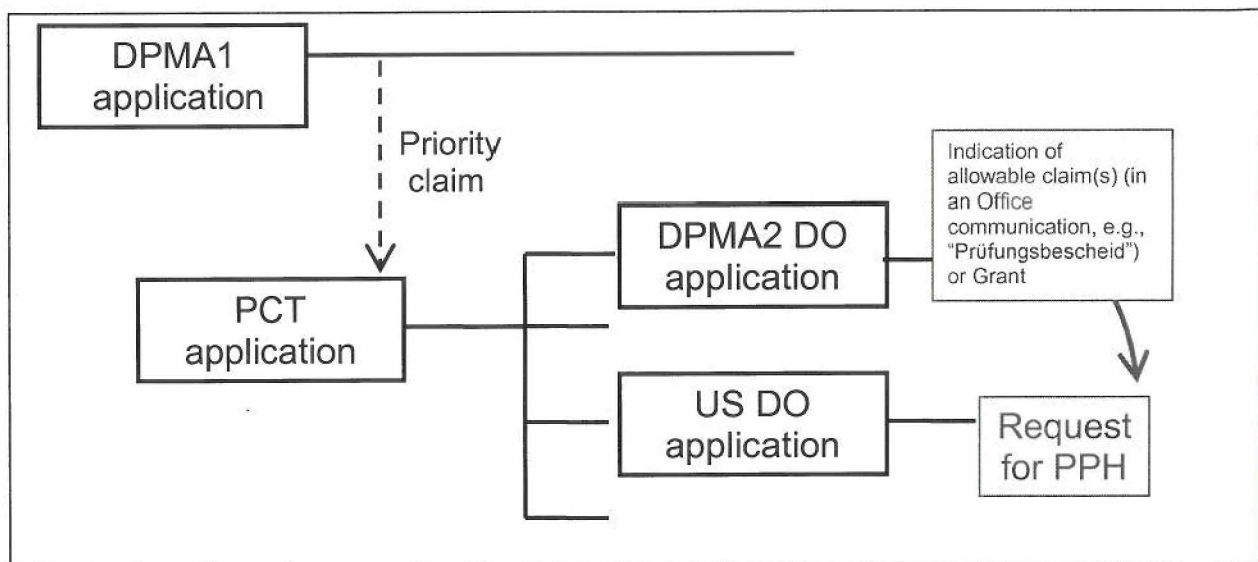

(1)(b)(ii):

- US application is a national stage of a PCT application which claims Paris Convention priority to another PCT application

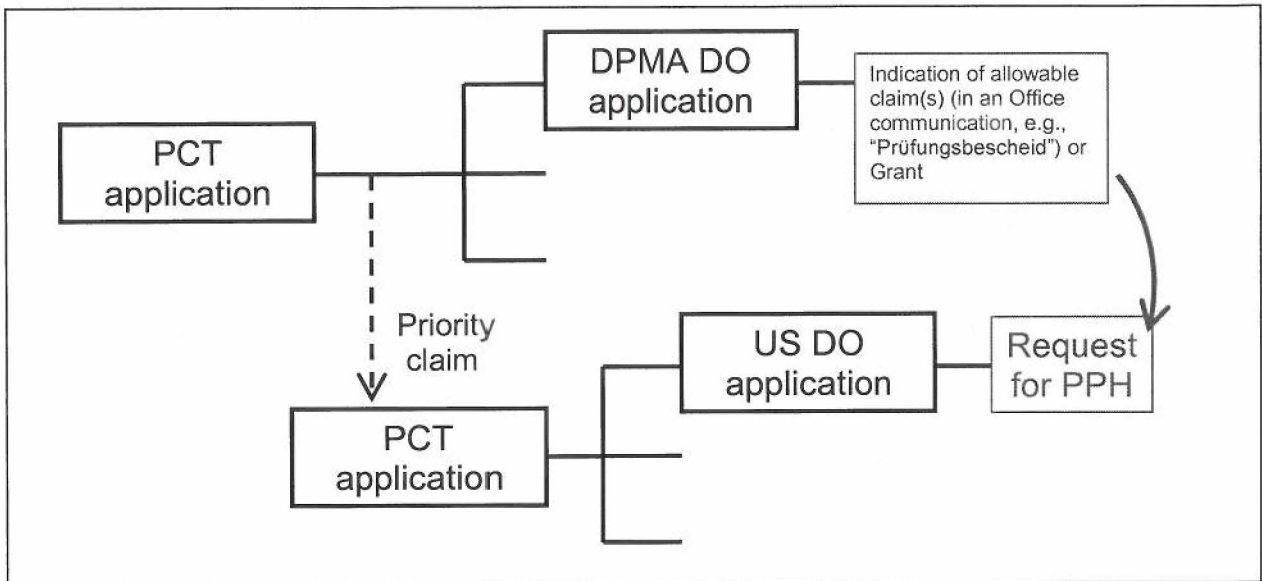

- Direct PCT and PCT Route

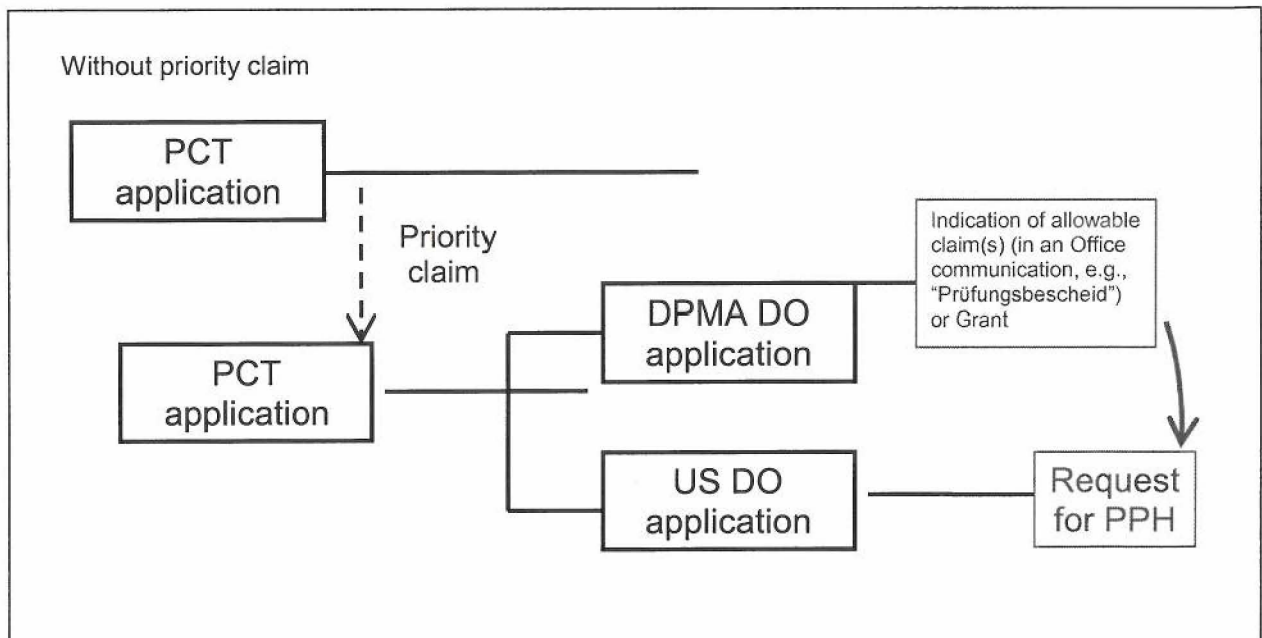

(1)(b)(iii):

- US application is a national stage of a PCT application without priority claim

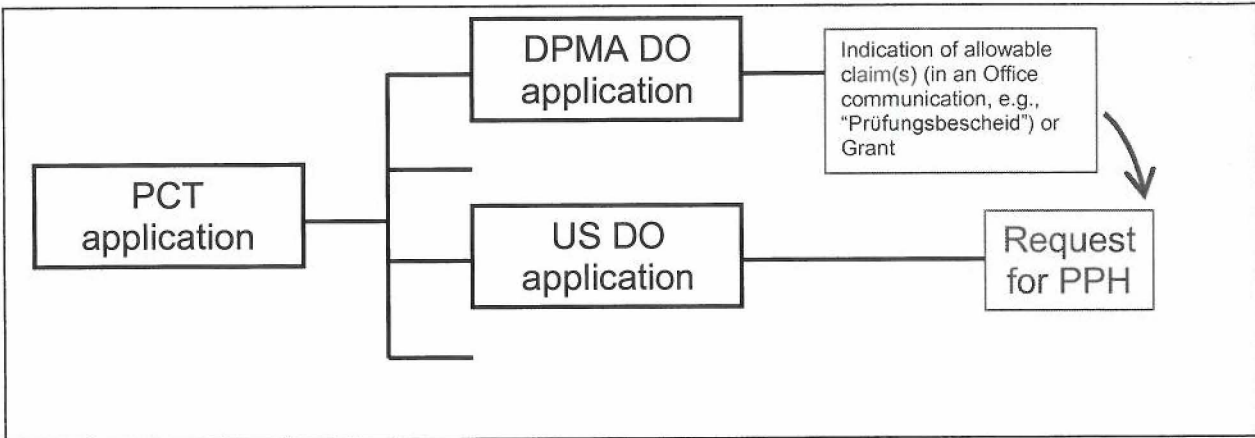

(1)(c)(i):

- US application is a 111(a) bypass of a PCT application which claims Paris Convention priority to a DPMA application

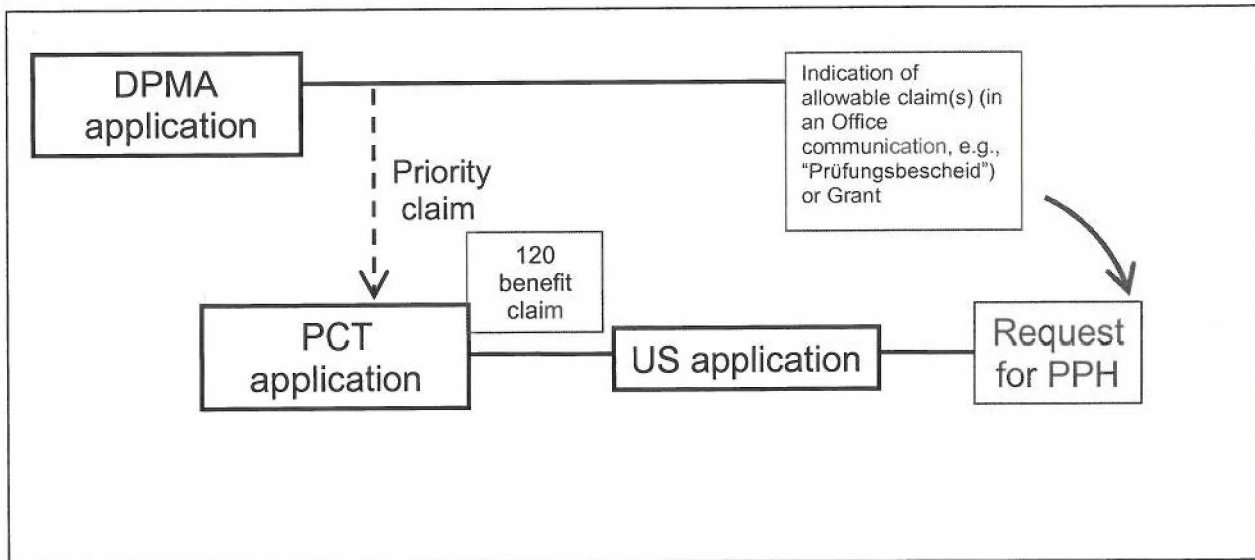

(1)(c)(ii):

- US application is a 111(a) bypass of a PCT application which claims Paris Convention priority to another PCT application

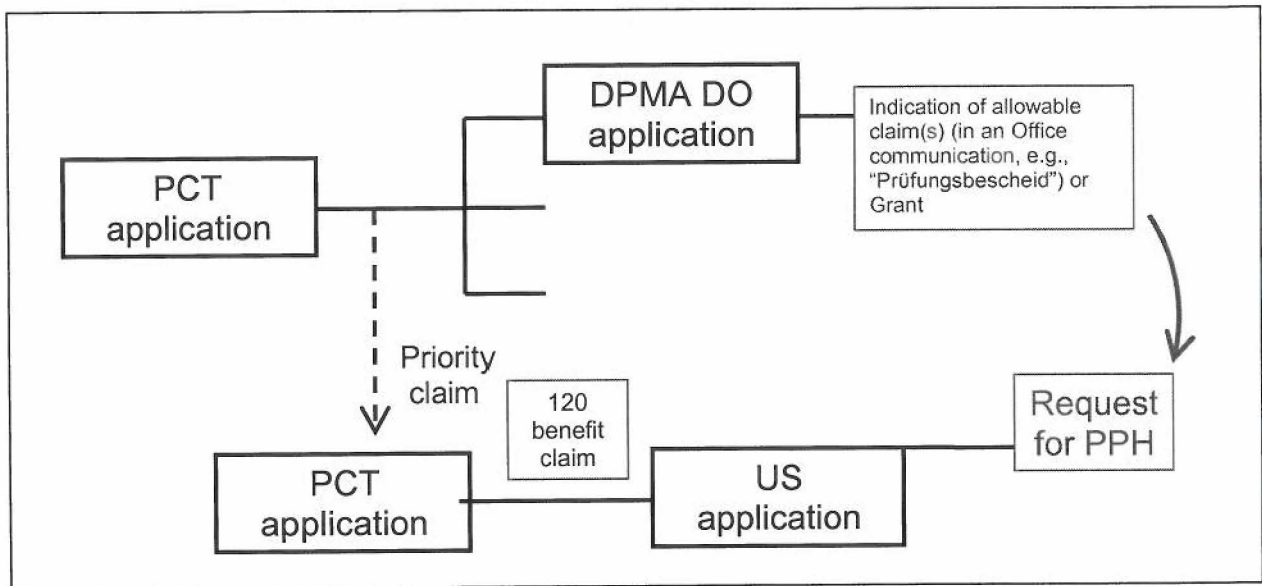

(1)(c)(iii):

- US application is a 111(a) bypass of a PCT application which contains no priority claim

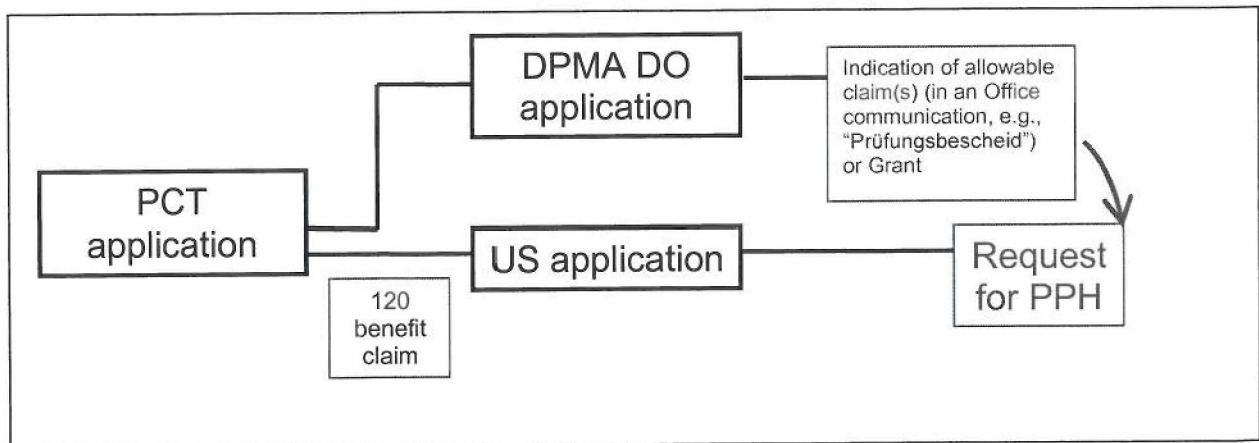

The DPMA application whose claims are determined to be allowable/patentable does not have to be the application for which priority is claimed in the USPTO application (the basic application). The DPMA application can be an application explicitly derived from the basic application, e.g., a divisional application of the basic application. Note that where the DPMA application that contains the allowable/patentable claims is not the same application for which priority is claimed in the U.S. application, applicant must identify the relationship between the DPMA application that contains the allowable/patentable claims and the DPMA priority application claimed in the U.S. application (e.g., DPMA application X that contains the allowable/patentable claims is a divisional application of DPMA application Y, which is the priority application claimed in the U.S. application).

Provisional applications, plant applications, design applications, reissue applications, reexamination proceedings, and applications subject to a secrecy order are excluded and not subject to participation in the PPH.

(2) The DPMA application(s) have at least one claim that was determined by the DPMA to be allowable/patentable (in a DPMA Office communication, e.g., “Prüfungsbescheid” or in a patent grant). Applicant must submit a copy of the allowable/patentable claims from the DPMA application(s) along with an English translation thereof and a statement that the English translation is accurate if the claims are not in the English language. If the DPMA office action does not explicitly state that a particular claim is allowable, applicant must include a statement in the request for participation in the PPH pilot program or in the transmittal letter accompanying the request for participation that no rejection has been made in the DPMA Office communication regarding that claim, and therefore, the claim is deemed allowable by the DPMA.

(3) All the claims in each U.S. application for which a request for participation in the PPH pilot program is made must sufficiently correspond to or be amended to sufficiently correspond to the allowable/patentable claims in the DPMA application(s). Claims will be considered to sufficiently correspond where, accounting for differences due to translations and claim format requirements, the claims are of the same or similar scope. Applicant is also required to submit a claims correspondence table in English. The claims correspondence table must indicate how all the claims in the U.S. application correspond to the allowable/patentable claims in the DPMA application(s).

(4) Examination of the U.S. application for which participation in the PPH pilot program is requested has not begun.

(5) Applicant must file a request for participation in the PPH pilot program and a petition to make the U.S. application special under the PPH pilot program. A sample request/petition form (PTO/SB/20DE) will be available from the USPTO Web site at <http://www.uspto.gov> on April 27, 2009. Applicants are encouraged to use the USPTO request/petition form. A petition fee under 37 CFR 1.17(h) for the petition to make special under 37 CFR 1.102(d) is required and must be submitted.

(6) Applicant must submit a copy of all the office actions (which are relevant to patentability) from each of the DPMA application(s) containing the allowable/patentable claims that are the basis for the request, along with an English translation thereof and a statement that the English translation is accurate if the office actions are not in the English language. In addition, applicant must submit copies of any office actions (which are relevant to patentability) from the DPMA application(s) issued after the grant of the request for participation in the PPH pilot program in the USPTO (especially where DPMA might have reversed a prior holding of allowability).

(7) Applicant must submit an information disclosure statement (IDS) listing the documents cited by the DPMA examiner in the DPMA office action (unless such an IDS has already been filed in the U.S. application). Applicant must submit copies of all the documents cited in the DPMA office action (unless the copies have already been filed in the U.S. application) except U.S. patents or U.S. patent application publications.

The request for participation in the PPH pilot program and all the supporting documents must be submitted to the USPTO via EFS-Web and indexed with the following document description: "Petition to make special under Patent Pros Hwy." Information regarding EFS-Web is available at http://www.uspto.gov/ebc/efs_help.html. Any preliminary amendments and IDS submitted with the PPH documents must be separately indexed as a preliminary amendment and IDS, respectively.

Where the request for participation in the PPH pilot program and special status are granted, applicant will be notified and the U.S. application will be advanced out of turn for examination. In those instances where the request for participation in the PPH pilot program does not meet all the requirements set forth above, applicant will be notified and the defects in the request will be identified. Applicant will be given one opportunity to perfect the request in a renewed request for participation (which must be submitted via EFS-Web and indexed accordingly as noted above). Note that action on the application by the examiner will NOT be suspended (37 CFR 1.103) awaiting a reply by the applicant to perfect the request in a renewed request for participation. That is, if the application is picked up for examination by the examiner after applicant has been notified of the defects in the request, any renewed request will be dismissed. If the renewed request is perfected and examination has not begun, the request and special status will be granted, applicant will be notified and the U.S. application will be advanced out of turn for examination. If not perfected, applicant will be notified and the application will await action in its regular turn.

(8) Request for participation in the PPH pilot program and special status granted in a parent application will not carry over to a continuing application. Applicant must fulfill all the conditions set forth above in order for special status to be granted in the continuing application.

If any of the documents identified in items (2), (6) and (7) above have already been filed in the U.S. application prior to the request for participation in the PPH pilot program, it will not be necessary for applicant to resubmit these documents with the request for participation. Applicant may simply refer to these documents and indicate in the request for participation in the PPH pilot program when these documents were previously filed in the U.S. application.

C. Special Examining Procedures

Once the request for participation in the PPH pilot program and special status have been granted to the U.S. application, the U.S. application will be taken up for examination by the U.S. examiner before all other categories of applications except those clearly in condition for allowance, those with set time limits, such as examiner's answers, and those that have been granted special status for "accelerated examination."

Any claims amended or added after the grant of the request for participation in the PPH pilot program must sufficiently correspond to one or more allowable/patentable claims in the DPMA application(s). Applicant is required to submit a claims correspondence table along with the amendment (see B.(3) above). If the amended or newly added claims do not sufficiently correspond to the allowable/patentable claims in the DPMA application(s), the amendment will not be entered and will be treated as a non-responsive reply.

The PPH program does not absolve applicants of all their duties under 37 CFR 1.56 and 37 CFR 11.18. By complying with requirements B.(6) and (7) identified above, applicants would be considered to have complied with their duties to bring to the attention of the USPTO any material prior art cited in the corresponding foreign application(s) (see MPEP § 2001.06(a)). Applicants still have a duty of candor and good faith, including providing to the USPTO other information known to them to be material to patentability.

Any inquiries concerning this notice may be directed to Magdalen Greenlief, Office of the Deputy Commissioner for Patent Examination Policy, at 571-272-8800 or at magdalen.greenlief@uspto.gov.

Date: 4/14/9



JOHN J. DOLL
Acting Under Secretary of Commerce for Intellectual Property and
Acting Director of the United States Patent and Trademark Office