

401 Physical Standards

Overview

- [1.0 Physical Standards for Parcels](#)
- [2.0 Additional Physical Standards by Class of Mail](#)

1.0 Physical Standards for Parcels

1.1 Processing Categories

USPS categorizes parcels into one of three mail processing categories: machinable, irregular, or outside parcel. These categories are based on the physical dimensions of the piece, regardless of the placement (orientation) of the delivery address on the piece.

1.2 Minimum Size

Pieces are subject to the minimum standards in [601.1.0, General Standards](#), and may be subject to other minimum dimensions, based on the standards for specific prices.

1.3 Maximum Weight and Size

No mailpiece may weigh more than 70 pounds. Lower weight limits apply to First-Class Mail, Standard Mail, and Bound Printed Matter. Pieces may not measure more than 108 inches in length and girth combined, except Parcel Select, which may not measure more than 130 inches in length and girth combined. For parcels, length is the distance of the longest dimension and girth is the distance around the thickest part. Lower size or weight standards apply to mail addressed to some APOs and FPOs subject to [703.2.0](#) and [703.4.0](#) and for Department of State mail, subject to [703.3.0](#).

1.4 Two or More Packages

Two or more packages may be mailed as a single parcel if they are about the same size or shape, are securely wrapped or fastened together, and do not exceed the weight or size limits.

1.5 Machinable Parcels

1.5.1 Criteria

A machinable parcel is any piece that is (see [Exhibit 1.5.1, Machinable Parcel Dimensions](#)):

- Not less than 6 inches long, 3 inches high, 1/4 inch thick, and 6 ounces in weight, except under [1.5.2](#). A mailpiece exactly 1/4 inch thick is subject to the 3 1/2-inch height minimum under [601.1.0](#).
- Not more than 34 inches long, or 17 inches high, or 17 inches thick, or 35 pounds in weight. For books or other printed matter, the maximum weight is 25 pounds.



Exhibit 1.5.1 Machinable Parcel Dimensions

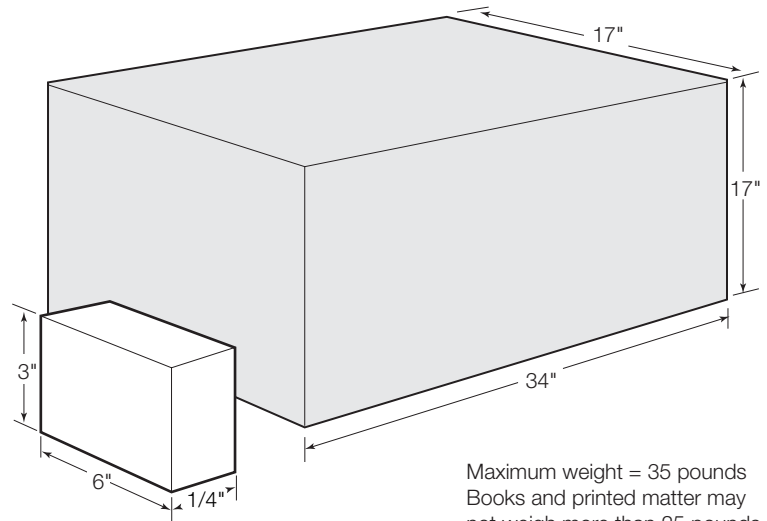

Minimum weight = 6 oz.
(for details, see machinable parcel criteria in 401.1.5.1)

1.5.2 Criteria for Lightweight Parcels

A machinable parcel may weigh less than 6 ounces (but not less than 3.5 ounces) if it meets all of the following conditions:

- a. The mailpiece is rectangular and able to maintain its integrity during mail processing (see 601.3.0).
- b. The mailpiece bears a parcel barcode, printed and placed according to 708.5.0.
- c. Mailpieces weighing at least 3.5 ounces but less than 5 ounces must be a paperboard or fiberboard box within the following dimensions:
 1. At least 1.5 inches thick and no more than 3 inches thick.
 2. At least 6 inches long and no more than 7 inches long.
 3. At least 3.5 inches high and no more than 5 inches high.
- d. Mailpieces weighing at least 5 ounces but less than 6 ounces must be within the following dimensions:
 1. More than 3/4 inch thick and no more than 6 inches thick.
 2. At least 6 inches long and no more than 12 inches long.
 3. At least 3-1/2 inches high and no more than 9 inches high.

1.5.3 Soft Goods and Enveloped Printed Matter

Soft goods wrapped in paper or plastic bags and enveloped printed matter are machinable only if all packaging standards in 601 are met.

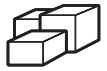

1.5.4 Exception

Some parcels may be successfully processed on BMC parcel sorters even though they do not conform to the general machinability criteria in 1.5.1. The manager, Network Distribution Center Operations, USPS Headquarters (see 608.8.1 for address) may authorize a mailer to enter such parcels as machinable parcels rather than irregular parcels if the parcels are tested on BMC parcel sorters and prove to be machinable. Mailers who wish to have parcels tested for machinability on USPS parcel sorting machines must:

- a. Submit a written request to Network Distribution Center Operations. The request must list mailpiece characteristics for every shape, weight, construction, and size to be considered. If the letter requesting testing describes a mailpiece that falls within the specifications of pieces that were tested previously, the mailpiece will not be acknowledged for testing.
- b. Define estimated number of parcels to be mailed in the coming year, and preparation level (e.g., destination BMC pallets).
- c. Upon acknowledgement from the manager, Network Distribution Center Operations, send 100 mailpiece samples to the designated test facility at least 6 weeks prior to the first mailing date. The manager, Network Distribution Center Operations will recommend changes to ensure machinability of parcels that do not qualify.

1.6 Irregular Parcel

An irregular parcel is a parcel not meeting the dimensional criteria in 1.5.1 or 1.5.2. This processing category also includes parcels that cannot be processed by BMC parcel sorters, including rolls and tubes up to 26 inches long; merchandise samples that are not individually addressed and are not letter-size or flat-size; unwrapped, paper-wrapped, or sleeve-wrapped articles that are not letter-size or flat-size; and articles enclosed in envelopes that are not letter-size, flat-size, or machinable parcels.

1.7 Outside Parcel

An outside parcel is a parcel that exceeds any of the maximum dimensions for a machinable parcel. This processing category also includes high-density parcels (other than books and printed matter) weighing more than 15 pounds and exerting more than 60 pounds per square foot (0.4167 pound per square inch) pressure on their smallest side; cartons containing more than 24 ounces of liquid in one or more glass containers; cartons containing 1 gallon or more of liquid in metal or plastic containers; cans, paints; rolls and tubes longer than 26 inches; metal-band strapped boxes, metal boxes, and wood boxes; articles not mailed in boxes or other containers; harmful matter; hazardous materials except ORM-D materials; and containers with all dimensions exceeding the minimum dimensions for a machinable (regular) parcel, if their coefficient of friction or ability to slide on a smooth, hard surface is not similar to that of a domestic-class fiberboard box of the same approximate size and weight.



2.0 Additional Physical Standards by Class of Mail

2.1 First-Class Mail Parcels

2.1.1 Weight

Matter at First-Class Mail prices cannot exceed 13 ounces. First-Class Mail weighing more than 13 ounces is Priority Mail.

2.1.2 Surcharge

Unless prepared in 5-digit/scheme containers or paid at a single-piece price, presorted parcels are subject to a \$0.05 surcharge if any of the following characteristics apply:

- a. The parcels weigh less than 2 ounces.
- b. The parcels do not bear a GS1-128 or POSTNET barcode.
- c. The parcels are irregularly shaped, such as rolls, tubes, and triangles.

2.1.3 Additional Physical Standards

[11-6-08] The address side of the parcel must be large enough to contain all delivery and return address, endorsement, postage, and label elements. First-Class Mail parcels are eligible for Delivery Confirmation and Signature Confirmation services. A First-Class Mail parcel is:

- a. A mailpiece that exceeds any one of the maximum dimensions for a flat (large envelope). See [101.2.1](#).
- b. A flat-size mailpiece, regardless of thickness, that is rigid or nonrectangular.
- c. A flat-size mailpiece that is not uniformly thick (has bumps, protrusions, or other irregularities that cause the thickness to vary more than 1/4 inch).

2.2 Standard Mail Parcels and Not Flat-Machinable Pieces

2.2.1 Additional Physical Standards

Each piece must weigh less than 16 ounces.

2.2.2 Not Flat-Machinable Pieces

Categorize Standard Mail with the following characteristics as Not Flat-Machinable pieces (unless mailed as parcels):

- a. Not Flat-Machinable pieces are rigid or are not uniformly thick, with the following dimensions:
 1. At least 4 inches high, but not more than 12 inches high.
 2. At least 4 inches long, but not more than 15-3/4 inches long.
 3. At least 0.009 thick, but not more than 1-1/4 inches thick. (Pieces less than 5 inches long must be over 1/4 inch thick.)
- b. Flexible pieces that are at least 4 inches high, but not more than 12 inches high, with either of the following dimensions:
 1. Over 15 inches long, but not more than 15-3/4 inches long.
 2. Over 3/4 inches thick, but not more than 1-1/4 inches thick.



2.2.3 Surcharge

Unless prepared in carrier route or 5-digit/scheme containers, Standard Mail parcels and Not Flat-Machinable pieces are subject to a \$0.05 surcharge if:

- a. The machinable parcels do not bear a GS1-128 barcode (see [708.5.0](#)) or the irregular parcels do not bear a GS1-128 barcode (see [708.5.0](#)) or POSTNET barcode (see [708.4.0](#)).
- b. The Not Flat-Machinable pieces weigh 6 ounces or more and do not bear a GS1-128 barcode (see [708.5.0](#)).
- c. The Not Flat-Machinable pieces weigh less than 6 ounces and do not bear a GS1-128 barcode (see [708.5.0](#)) or POSTNET barcode (see [708.4.0](#)).

2.3 Parcel Select

2.3.1 General Standards

These standards apply to Parcel Select:

- a. Parcel Select pieces measuring over 108 inches in combined length and girth, but not more than 130 inches in combined length and girth, are mailable at the applicable oversized price.
- b. An item weighing less than 20 pounds but measuring more than 84 inches (but not more than 108 inches) in combined length and girth is charged the price for a 20-pound parcel for the zone to which it is addressed (balloon price).

2.3.2 Nonmachinable Parcel Select

Mailpieces described in this section that are mailed at Parcel Select prices are subject to the applicable nonmachinable surcharge in [453.1.0](#) unless the applicable special handling fee is paid. An oversized parcel as described in [2.3.1a](#) is not subject to the nonmachinable surcharge. Mailpieces are nonmachinable if they meet any of the following criteria:

- a. A parcel more than 34 inches long, 17 inches wide, or 17 inches high.
- b. A parcel less than 6 inches long, 1/4 inch thick, or 3 inches high.
- c. A parcel that weighs less than 6 ounces or more than 35 pounds, except under [1.5.2](#) for lightweight parcels.
- d. A parcel containing more than 24 ounces of liquid in glass containers, or 1 gallon or more of liquid in metal or plastic containers.
- e. An insecurely wrapped or metal-banded parcel.
- f. A can, roll, or tube, or wooden or metal box.
- g. Books, printed matter, or business forms weighing more than 25 pounds.
- h. A high-density parcel weighing more than 15 pounds and exerting more than 60 pounds per-square-foot pressure on its smallest side.
- i. A film case weighing more than 5 pounds or with strap-type closures, except any film case the USPS authorizes to be entered as a machinable parcel under [1.0](#) and to be identified by the words "Machinable in United States Postal Service Equipment" permanently attached as a nontransferable decal in the lower right corner of the case.

- j. Parcels with characteristics (such as inadequate packaging) that could result in damage to the contents of the mailpiece, other parcels, or postal machinery if mechanical sortation is used.

2.4 Bound Printed Matter Parcels

2.4.1 General Standards

Pieces mailed at Bound Printed Matter prices may not weigh more than 15 pounds.