

# Renewable Electrolysis Integrated System Development and Testing

**Ben Kroposki**

National Renewable Energy Laboratory

May 16, 2006

Presented at the 2006 DOE Hydrogen, Fuel Cells & Infrastructure Technologies Program Review

**This presentation does not contain any proprietary or confidential information.**

### **Disclaimer and Government License**

This work has been authored by Midwest Research Institute (MRI) under Contract No. DE-AC36-99GO10337 with the U.S. Department of Energy (the “DOE”). The United States Government (the “Government”) retains and the publisher, by accepting the work for publication, acknowledges that the Government retains a non-exclusive, paid-up, irrevocable, worldwide license to publish or reproduce the published form of this work, or allow others to do so, for Government purposes.

Neither MRI, the DOE, the Government, nor any other agency thereof, nor any of their employees, makes any warranty, express or implied, or assumes any liability or responsibility for the accuracy, completeness, or usefulness of any information, apparatus, product, or process disclosed, or represents that its use would not infringe any privately owned rights. Reference herein to any specific commercial product, process, or service by trade name, trademark, manufacturer, or otherwise does not constitute or imply its endorsement, recommendation, or favoring by the Government or any agency thereof. The views and opinions of the authors and/or presenters expressed herein do not necessarily state or reflect those of MRI, the DOE, the Government, or any agency thereof.

# Overview

## Timeline

Project Start Date: 9/2003

Project End Date: Ongoing

## Budget

Total Project Funding:

FY05 - \$400K DOE

FY06 - **\$625K** DOE

- **\$1.3M** Industry cost share

## Production Barriers

- G. Cost
- H. System efficiency
- J. Renewable integration

## Partners

- **Xcel Energy**
- **Proton Energy**
- **Teledyne**
- **Northern Power Systems**
- **Hydrogen Engine Center**
- **Univ. of North Dakota**
- **Univ. of Minnesota**
- **Basin Electric**
- **Ft. Collins Utilities**
- **DOE Wind/Hydro Program**

# Presentation Outline

- Overview
- Objectives
- Background
- Approach
- Technical Accomplishments
  - Hydrogen Utility Group (HUG)
  - Economic Analysis of Wind-Electrolysis
  - Current Wind-Electrolysis Testing
  - Planned Projects and Collaborations
- Future Plans
- Summary

# Project Objectives

This project examines the issues with using renewable energy to produce hydrogen by electrolyzing water

- Characterize electrolyzer performance under variable input power conditions
- Design and develop shared power electronics packages and controllers to reduce cost and optimize system performance and identify opportunities for system cost reduction through breakthroughs in component integration
- Test, evaluate, and optimize the renewable electrolysis system performance for both
  - Dedicated hydrogen production
  - Electricity/hydrogen cogeneration
- Verify DOE goals of:
  - grid-connected electrolysis cost of \$2.85/kg by 2010
  - renewable hydrogen production cost of \$2.75/kg by 2015.

# Project Background

## *Importance and Need – Project Focus*

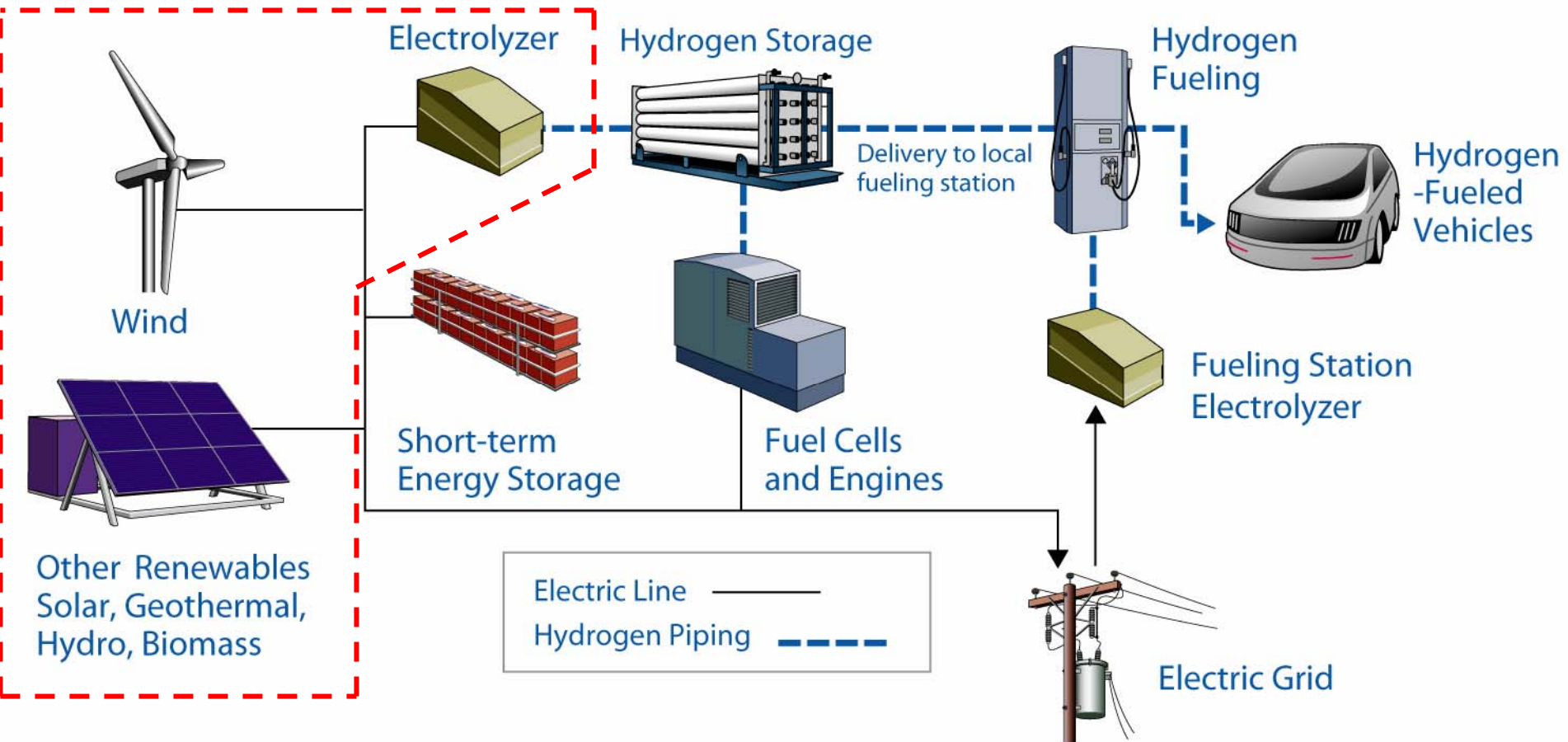

# Project Approach

## 1. Coordination, Planning, and Stakeholder Development

Work with DOE and industry to develop roadmap for renewable electrolysis and system development

## 2. Systems Engineering, Modeling, and Analysis

Develop concept platforms, develop and validate component and system models, system assessment, and optimization tools

## 3. System Integration and Component Development

Work with industry to develop new advanced hardware and control strategies to couple renewable and electrolyzer systems

## 4. Characterization Testing and Protocol Development

Equipment installation, performance characterization, standard test procedure development

# Technical Accomplishments

## Hydrogen Utility Group

- Founded in October 2005 with support from DOE, NREL, EPRI, NHA
- NREL's role has been to facilitate the organization of the group and share hydrogen experience
- Meetings in Nov. 05 and Jan. 06
- Senate Caucus – Feb. 2006
- Two sessions at NHA meeting
- Over 10 active utility members
- Membership is open to electric and combined electric/gas utilities and others as approved by the Steering Committee





# Technical Accomplishments

## Hydrogen Utility Group

**Mission:** To accelerate utility integration of promising hydrogen energy related business applications through the coordinated efforts and actions of its members, in collaboration with key stakeholders, including government agencies and utility support organizations

- Power companies are looking for ways to better serve their customers' future energy needs
- Hydrogen system integration efforts can be aided by sharing data / lessons learned between companies
- Common questions to the power industry are best considered collectively, rather than individually
- Electrolysis is a near-term focus for using electricity to produce hydrogen



# Technical Accomplishments

## Economics of Wind Electrolysis

- Electricity prices need to be under \$0.055/kWh to meet DOE targets using current efficiencies
- Wind is the fastest growing renewable energy source (2,500MW installed in 2005 in US)
- Wind is a cost effective renewable energy source (\$0.03-\$0.05/kWh)

Hydrogen costs via electrolysis with electricity costs only

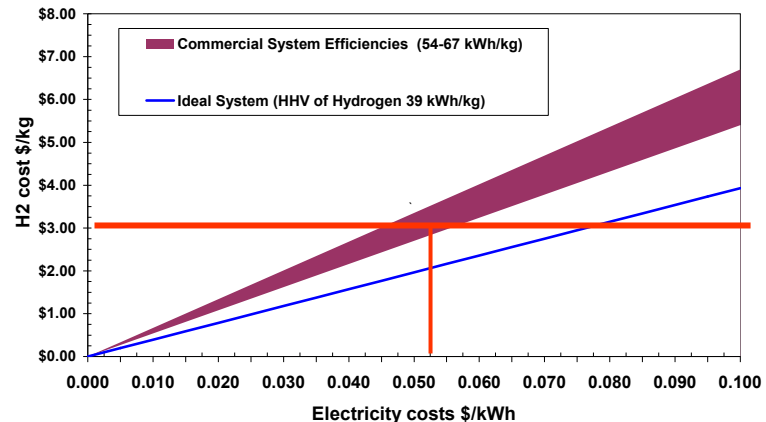

Cost figures include the current wind production tax credit.

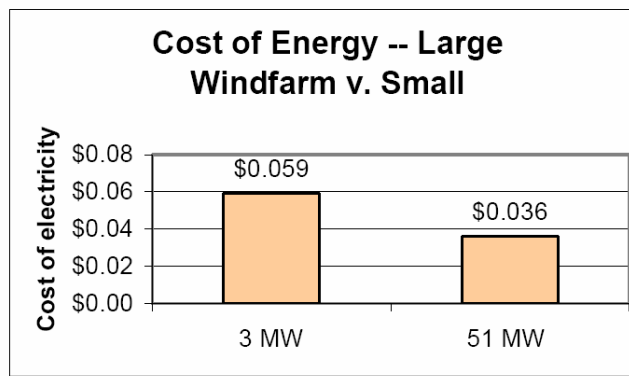

Economics of Wind – [www.awea.org](http://www.awea.org)



# Technical Accomplishments

## Economics of Pure-Wind Electrolysis for Xcel Energy

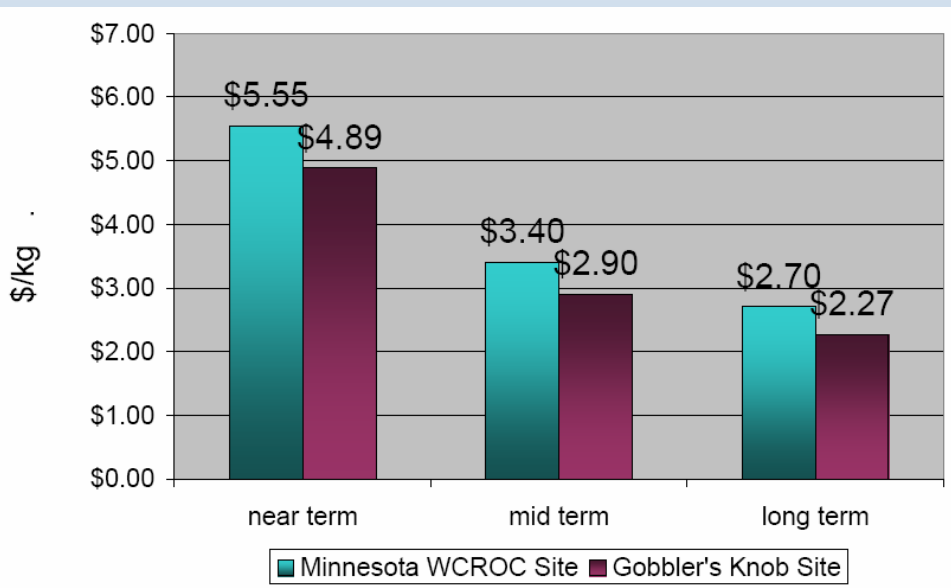
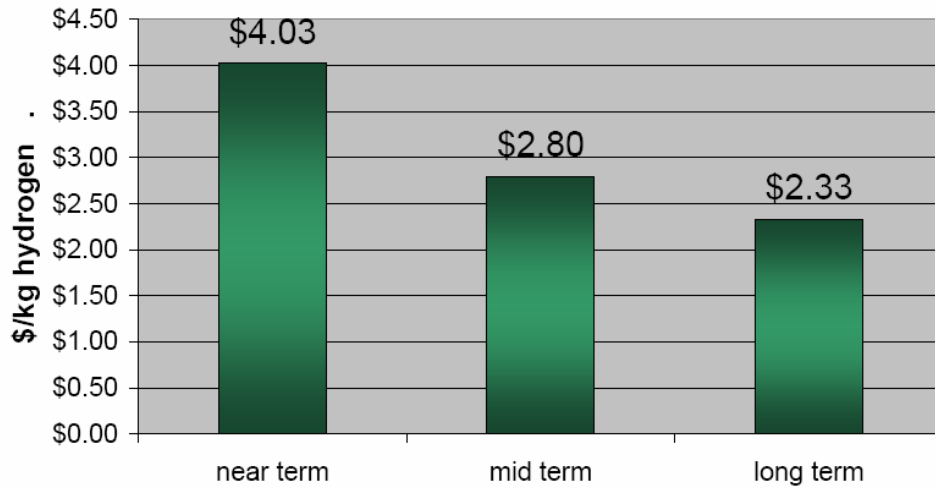

### Distributed Electrolysis

- Cost of hydrogen for distributed H<sub>2</sub> production from aggregated wind
- High capacity factor
- Wind electricity price (\$0.038/kWh)

### Central Electrolysis

- Cost of hydrogen at wind farm site. Does not include delivery
- Does not include any added efficiency of co-locating systems
- Lower capacity factor based on single location
- Wind electricity price (\$0.038/kWh)

# Technical Accomplishments

## Current Wind-Electrolysis Project

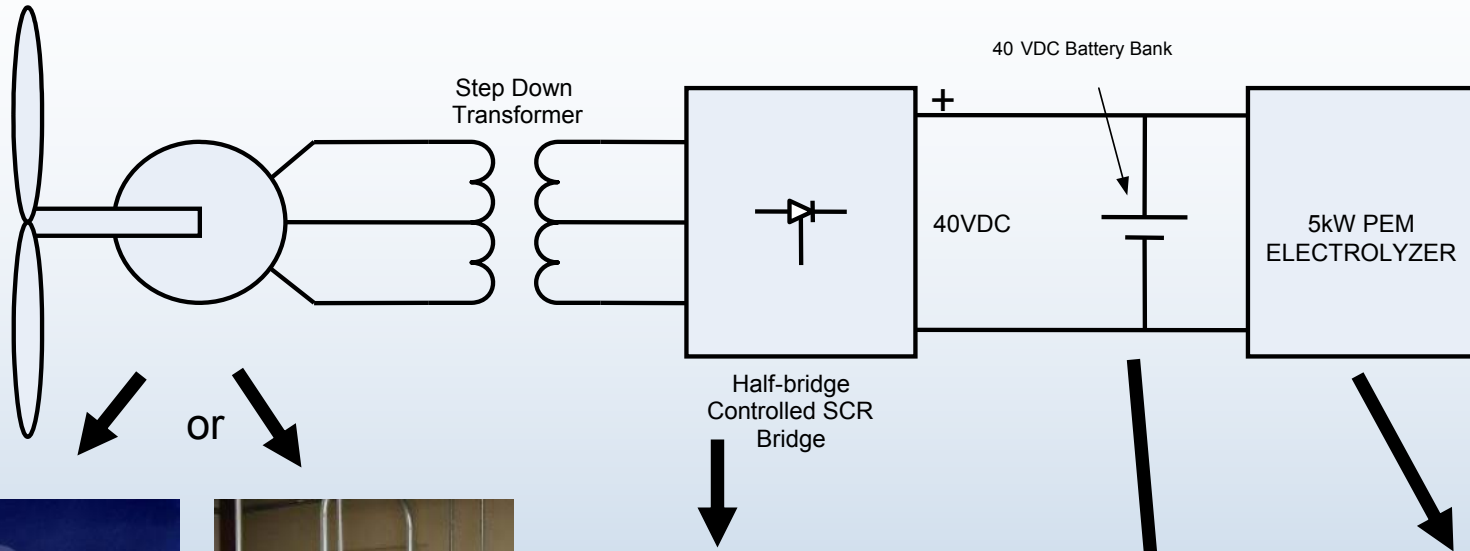

10kW Wind Turbine



AC Source (Wind Turbine) Simulator



AC-DC Power Electronics



Battery Bank



5kW PEM Electrolyzer

# Technical Accomplishments

## Prototype Electrolyzer Performance Testing

Characterization with simulated low-wind speed conditions

- This shows current into electrolyzer stack from wind turbine

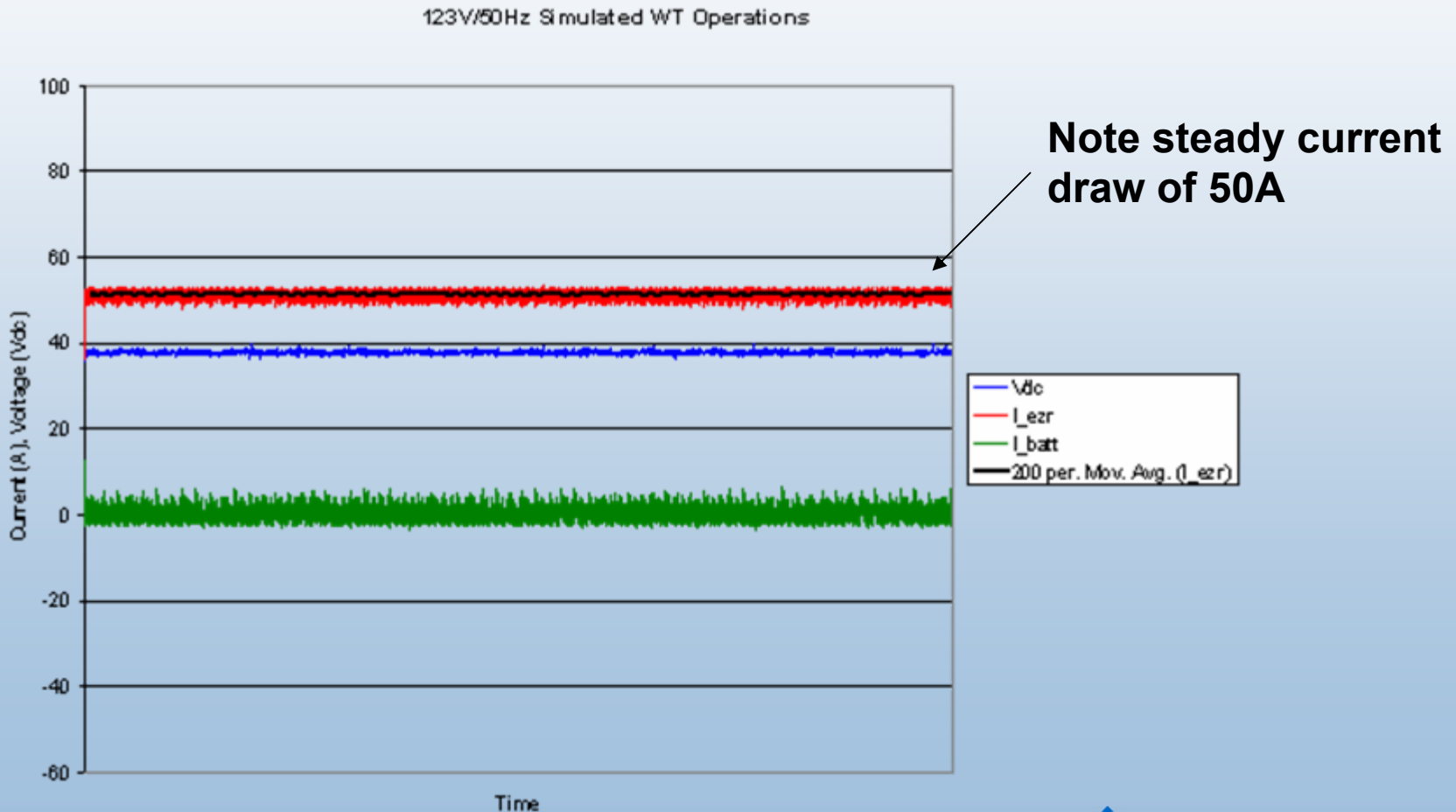

# Technical Accomplishments

## Prototype Electrolyzer Performance Testing

Characterization with simulated high-wind speed condition

272V/131Hz Simulated WT Operations

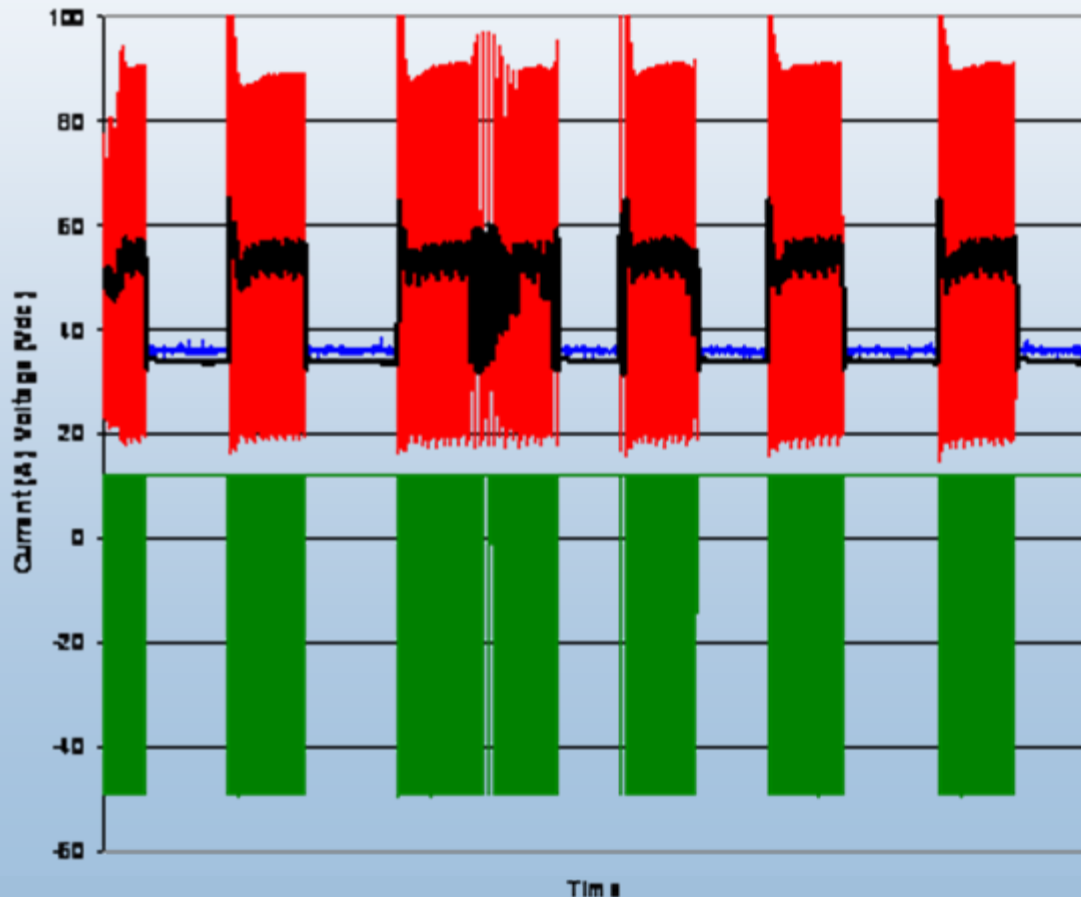

- High wind speed
- Power electronics (PE) regulating voltage
- 50A avg. current
- No added benefit of high winds with current PE interface

- Building new PE interface this year

- Building block PE for next generation designs

# Technical Accomplishments

## Power Electronics Interface Development

- Off the shelf power electronics do not exist in the size range and application for wind-electrolysis use
- This project will build a configurable platform based on standard PE devices but have the ability to change control system based on operational parameters

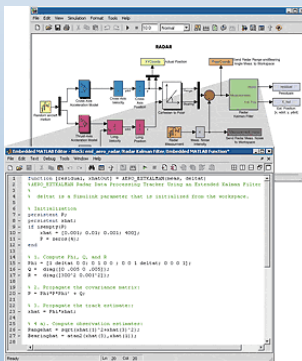

**Build Control System in Simulink based on wind/electrolyzer input/outputs**



**Generate code for controller – download to processor**



**Industry developed and standardized power electronics based AC-DC or DC-DC converters**



# Technical Accomplishments Xcel-NREL Wind2H2 Project

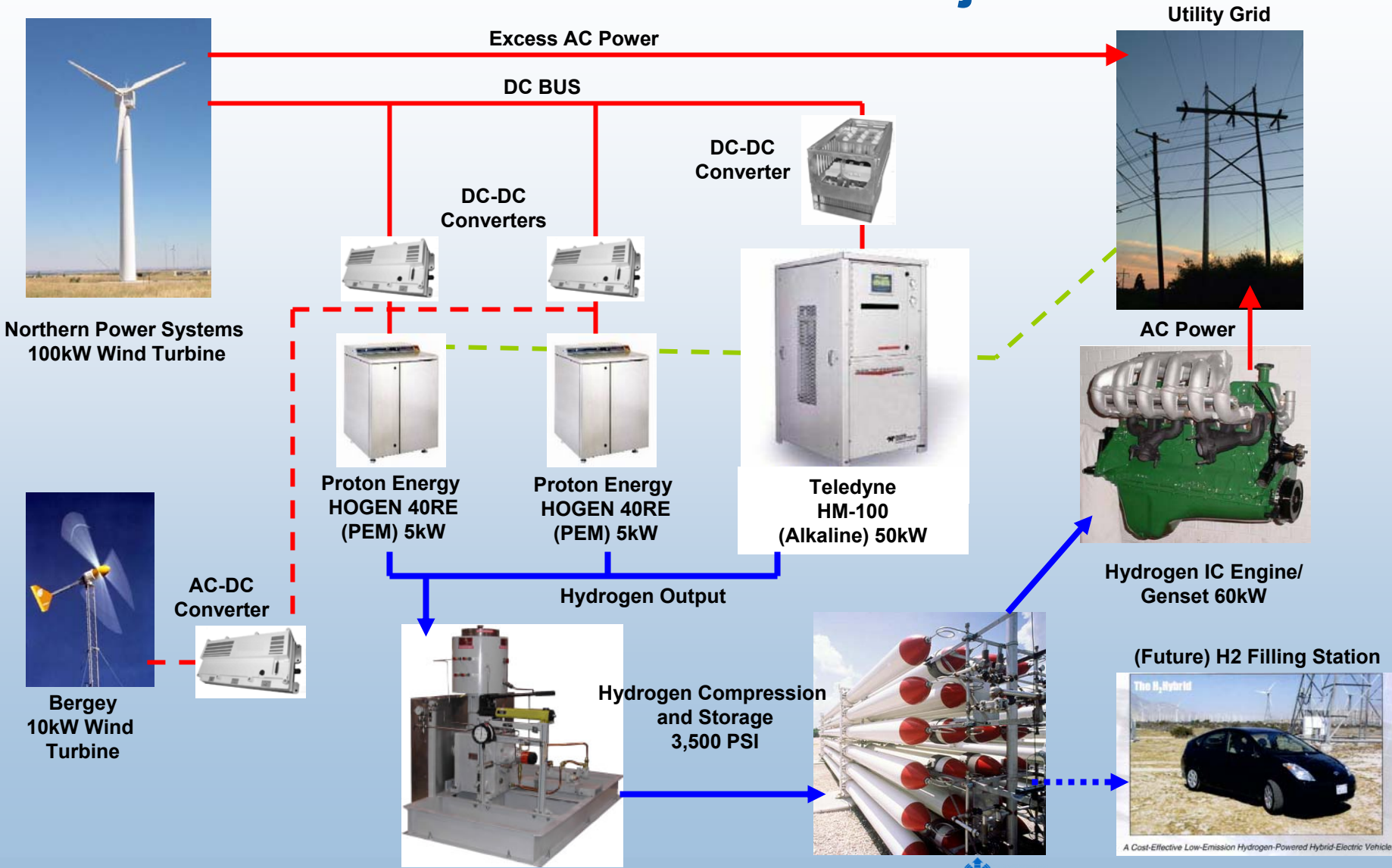



# Technical Accomplishments Xcel-NREL Wind2H2 Project

## Grid Connected Mode

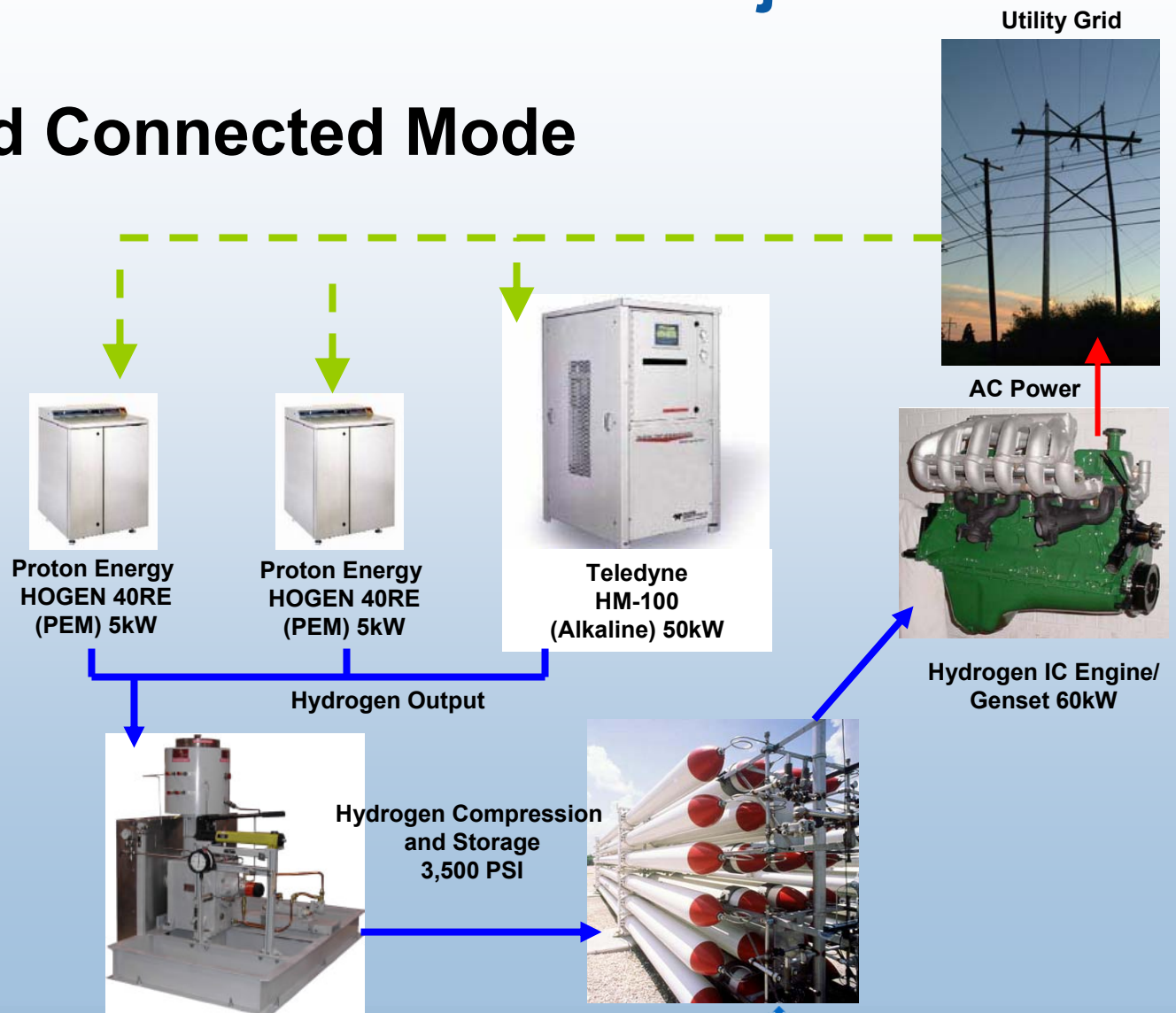

# Technical Accomplishments Xcel-NREL Wind2H2 Project

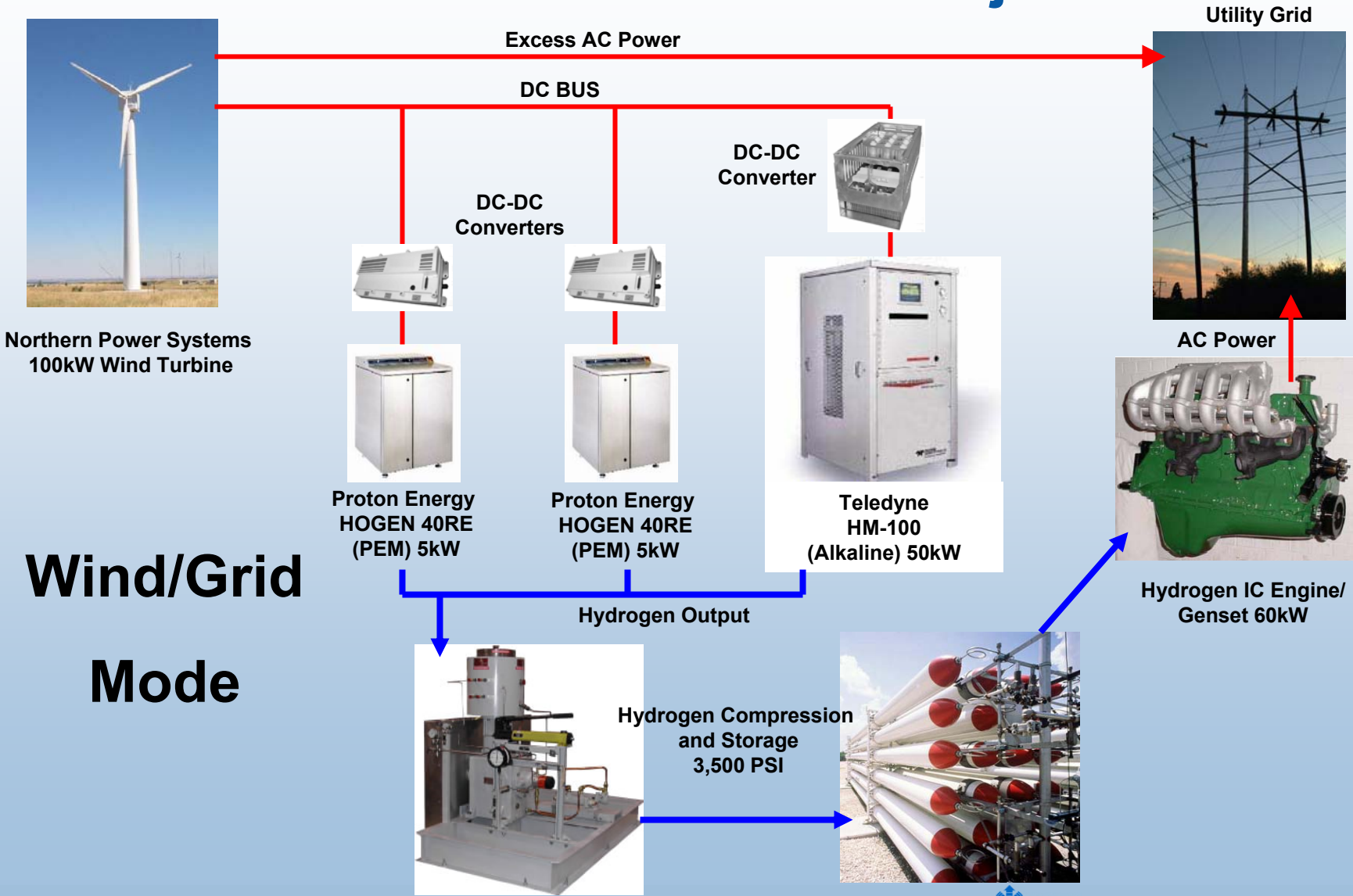

# Technical Accomplishments Xcel-NREL Wind2H2 Project

## Off-Grid Mode

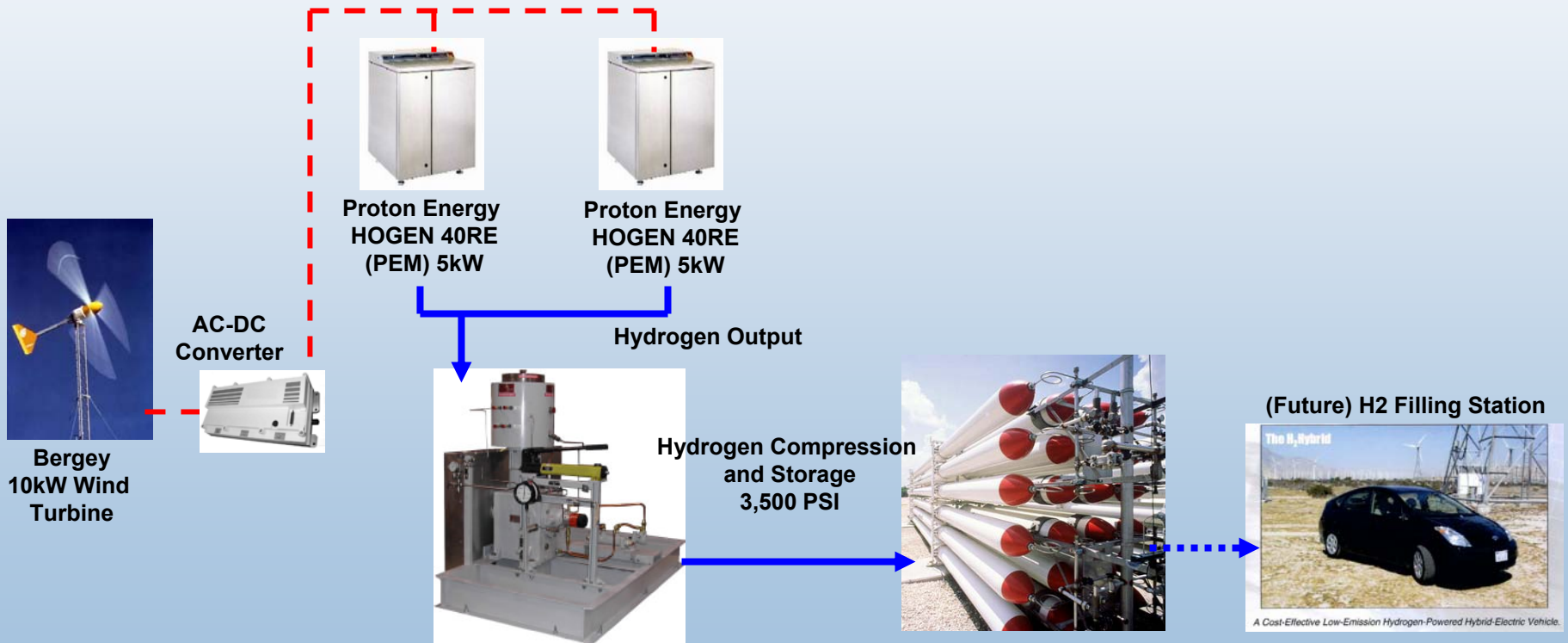

# Technical Accomplishments

## Xcel-NREL Wind2H2 Project

### Benefits of the Project

- 1) *Exploring how to make hydrogen without producing greenhouse gasses or other harmful by-products*
- 2) *Creating synergies from co-production of electricity and hydrogen*
  - By storing hydrogen for later use, the project addresses the intermittent nature of wind power, creating a ready source of electricity for when the wind doesn't blow or the demand for electricity is high.
  - Consistent support of the electric grid from off-peak storage of hydrogen
  - Potential hydrogen production for vehicle use
- 3) *Comparing alkaline and PEM electrolyzer technologies*
- 4) *Achieving efficiency gains through a unique integrated DC-to-DC connection between the wind turbine and the electrolyzers being studied*

# Added Value from Collaboration

- Coordinated “Wind Storage”
- DC/DC Interface
- Re-deployable

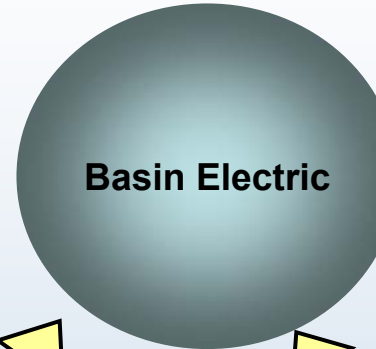
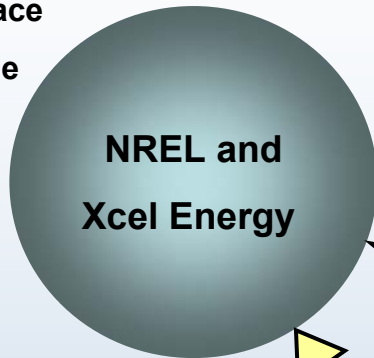

- Larger Scale “Wind Storage”
- Vehicle Applications



- Larger Scale “Wind Storage”
- Anhydrous Ammonia Production
- Vehicle & Hybrid Applications

- High-Pressure Electrolysis
- Vehicle Fueling Station & Fuel Cell
- Hydrogen/Natural Gas Mixing

- Parallel timetables
- Inter-project collaboration, data sharing and H2 safety
- Welcome additional partners to the informal renewable electrolysis collaborative

# Future Work

## Remainder of FY06

- Complete installation of Wind2H2 Project

## FY07 Plans

- Start test program on Wind2H2 Project
- Complete standard test protocol development for renewable-electrolyzer performance and operation  
(Possible IPHE Project)
- Model/simulation of renewable-electrolyzer performance

## FY08-FY10 Plans

- Based on experience with Wind2H2 Project look at possible tests of 1.5MW wind turbine/electrolyzer project

# Summary Slide

- Economic analysis shows that renewable electrolysis can meet DOE hydrogen cost targets
- Working with Hydrogen Utility Group to examine how utilities can effectively make and use hydrogen
- Multi-partner collaborative effort to evaluate renewable electrolysis (industry, universities, utilities, government)
- Research on cost reductions and efficiency gains in renewable electrolysis systems integration

# Responses to Previous Year Reviewers' Comments

**Comment:** To few publications so far.

**Response:** This project has published two papers at conferences this year and several more are in the works. As results are verified, they will become public.

**Comment:** Focus on system costs.

**Response:** Initial economic study was conducted with Xcel Energy on Wind-Electrolysis. Results are included in current publication. Results also used to meet DOE Joule milestone

**Comment:** Include storage and use of hydrogen in project.

**Response:** Wind2H2 Project will include hydrogen compression, storage, and use for a real-world application.



# Publications and Presentations

*“Wind Energy and Production of Hydrogen and Electricity -- Opportunities for Renewable Hydrogen: Preprint.”* Levene, J.; Kroposki, B.; Sverdrup, G. CP-560-39534, 2006 POWER-GEN Renewable Energy and Fuels Technical Conference, April 10-12 2006, Las Vegas, Nevada.

*“Characterizing Electrolyzer Performance for Use with Wind Turbines”*, Harrison, K., Kroposki, B., Pink, C. AWEA Conference, June 4-7 2006, Pittsburg, PA.

# Critical Assumptions and Issues

## Assumptions

- Electrolysis coupled directly with renewable systems is technically and economically feasible.
- There is a cost savings and efficiency gain by coupling renewable systems and electrolyzers.
- Renewable electrolysis is the best near-term carbon-free hydrogen production solution.

## Issues

- Utilities need more information on hydrogen production, storage, and use. Need to continue collaboration.
- Hydrogen may be a solution to the storage of energy needed by intermittent renewable energy systems.
- Analysis need to be done to see when and if hydrogen storage makes sense.
- Need to improve electrolyzer costs and efficiencies.

# Project Timeline

## Renewable Electrolysis - Integrated Systems Development and Testing

Coordination, Planning and Stakeholder Development

System Integration and Component Development

System Engineering and Modeling

Characterization Testing and Protocol Development

