

# Historical Context of W Site, Technical Area 41

## Volume 1

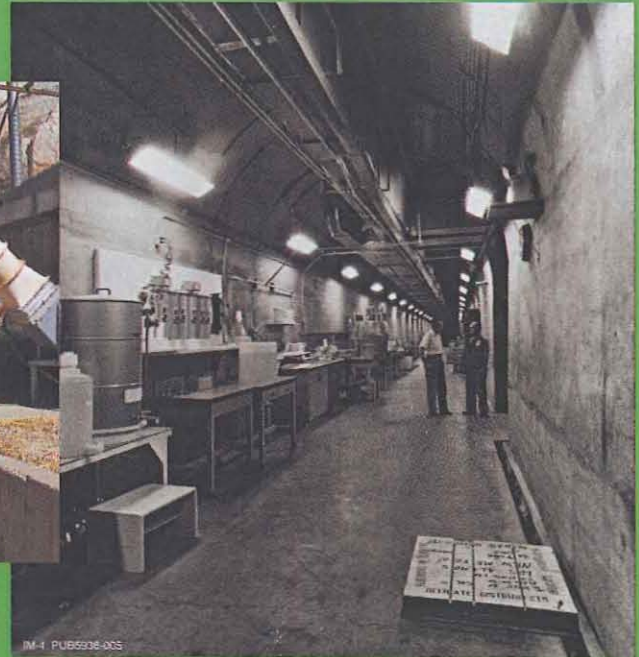

TA-41-1 "Tunnel and Vault"



IM-4 PUB5936-005

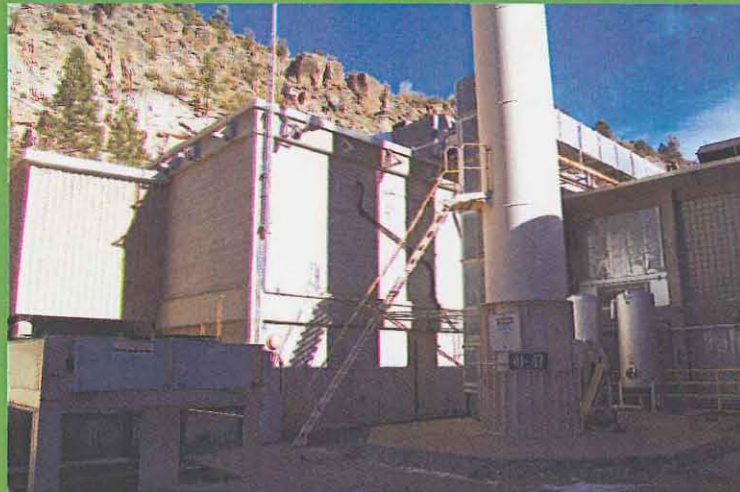

TA-41-4 Laboratory

**LA-UR-04-6492**

**Historical Context of W Site,  
Technical Area 41**

Historic Building Report No. 231

**Los Alamos National Laboratory**

**September 10, 2004**

**Survey No. 887**

Prepared for the  
Department of Energy, National Nuclear Security Administration,  
Los Alamos Site Office

prepared by

**Ellen D. McGehee and Kari L. M. Garcia**, Heritage Resource Managers,  
LANL Ecology Group (RRES-ECO)

**Erik Loomis**, Graduate Research Assistant, LANL Ecology Group (RRES-ECO)

**Ken Towery**, Architect, LANL Site and Project Planning Group (PM-1)

**John Ronquillo**, Consulting Engineer, Sigma Science, Inc.

**John Isaacson**, HREPC Team Leader, LANL Ecology Group (RRES-ECO)

RRES-ECO Heritage Resources and Environmental Policy Compliance (HREPC) Team  
Risk Reduction and Environmental Stewardship Division  
LOS ALAMOS NATIONAL LABORATORY

## TABLE OF CONTENTS

**Volume 1**

Acronyms.....	3
Introduction.....	4
Historical Overview	
Manhattan Project (1942–1946) .....	8
Early Cold War Era (1946–1956) .....	12
Late Cold War Era (1956–1990).....	13
Historical Context of Technical Area (TA) 41, W Site (1948–2002)	
General Overview and Facility Description.....	14
TA-41 and the Nation’s Nuclear Stockpile.....	15
Weapons Storage Sites and the Role of Black and Veatch.....	16
TA-41 and the Development and Testing of the Hydrogen Bomb .....	16
TA-41 and the Gas Handling Facility at TA-33.....	19
The Ice House – TA-41-4 .....	19
The Tunnel – TA-41-1 .....	22
Los Alamos Neutrino Experiments.....	26
Descriptions of MOA Properties	
Building Identification and Numbering .....	28
TA-41-1 (and TA-41-3) .....	28
TA-41-2.....	29
TA-41-4 (and TA-41-6 & TA-41-47) .....	30
TA-41-16.....	32
References Cited.....	33
List of Appendices	
Appendix A Historic Building Inventory Forms with Representative Photographs and Building Drawings	
Appendix B Facility Location Maps Showing Location of Eligible and Non- Eligible Properties and TA-41 Construction History	
Appendix C Interview Information	
Appendix D Complete Listing of Facility Drawings on File at LANL	

**Volume 2**

Archival Photographs with Index

## ACRONYMS

AEC – Atomic Energy Commission

LANL – Los Alamos National Laboratory

LASO – Department of Energy, National Nuclear Security Administration,  
Los Alamos Site Office

MOA – Memorandum of Agreement

NTS – Nevada Test Site

SHPO – State Historic Preservation Officer

TA – Technical Area

## INTRODUCTION

The following documentation fulfills the terms set forth in a memorandum of agreement (MOA) between the Department of Energy, National Nuclear Security Administration, Los Alamos Site Office (LASO) and the New Mexico Historic Preservation Division regarding the demolition, modification, or abandonment of buildings and structures 1, 2, 3, 4, 6, 16, and 47 at Technical Area (TA) 41, Los Alamos National Laboratory (LANL). TA-41-1, -2, -3, -4, -6, -16, and -47 were determined eligible for the National Register of Historic Places under Criterion A in correspondence between the New Mexico State Historic Preservation Officer (SHPO) and LASO on May 22, 2002. The initial recommendations for eligibility are contained in a report written by LANL heritage resource managers (*Decontamination and Decommissioning of Technical Area 41*, Historic Building Survey Report No. 204, LA-UR-02-2663).

Work processes carried out at TA-41 supported Cold War weapons development and long-term studies of weapons subsystems from the late 1940s to the present (LANL 1993a:1-3). The main facilities at TA-41 were built between 1948 and 1951, and are located in Los Alamos Canyon, immediately south of the town of Los Alamos, New Mexico (Figure 1) (Maps 1 and 2). As part of LANL facility consolidation and revitalization activities, TA-41's operations were recently moved to Los Alamos's TA-16. The vacated laboratory and office facilities at TA-41 were identified as excess property and some of the buildings were scheduled for decontamination and decommissioning in accordance with LANL's responsibility for cleaning up inactive sites and facilities. The removal of properties at TA-41 became an even higher priority when it was determined that severe flooding in Los Alamos Canyon could cause catastrophic damage to buildings located within the new flood zone established after the May 2000 Cerro Grande fire. Of the properties included in the MOA, TA-41-16 and the office portion of TA-41-4 were eventually demolished. The high bay and rear laboratory portions of TA-41-4 were retained along with the vault (TA-41-1) and an associated guardhouse (TA-41-2). Three attached support structures (air intake TA-41-3, corridor TA-41-6, and exhaust stack TA-41-47) and some of the associated building utilities

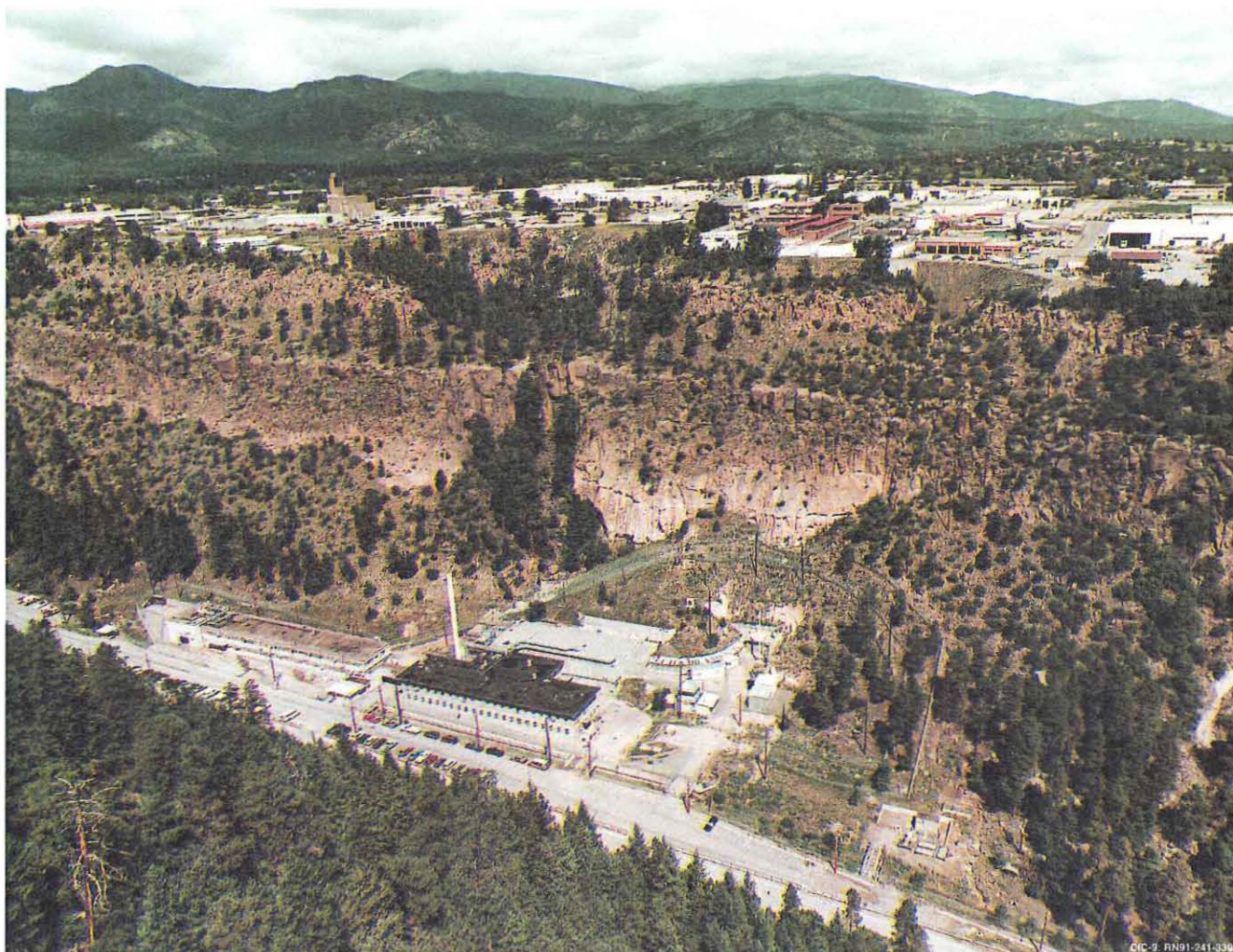

(LANL, IM-9 Photography, #RN91-241-339)

Figure 1. TA-41, 1991

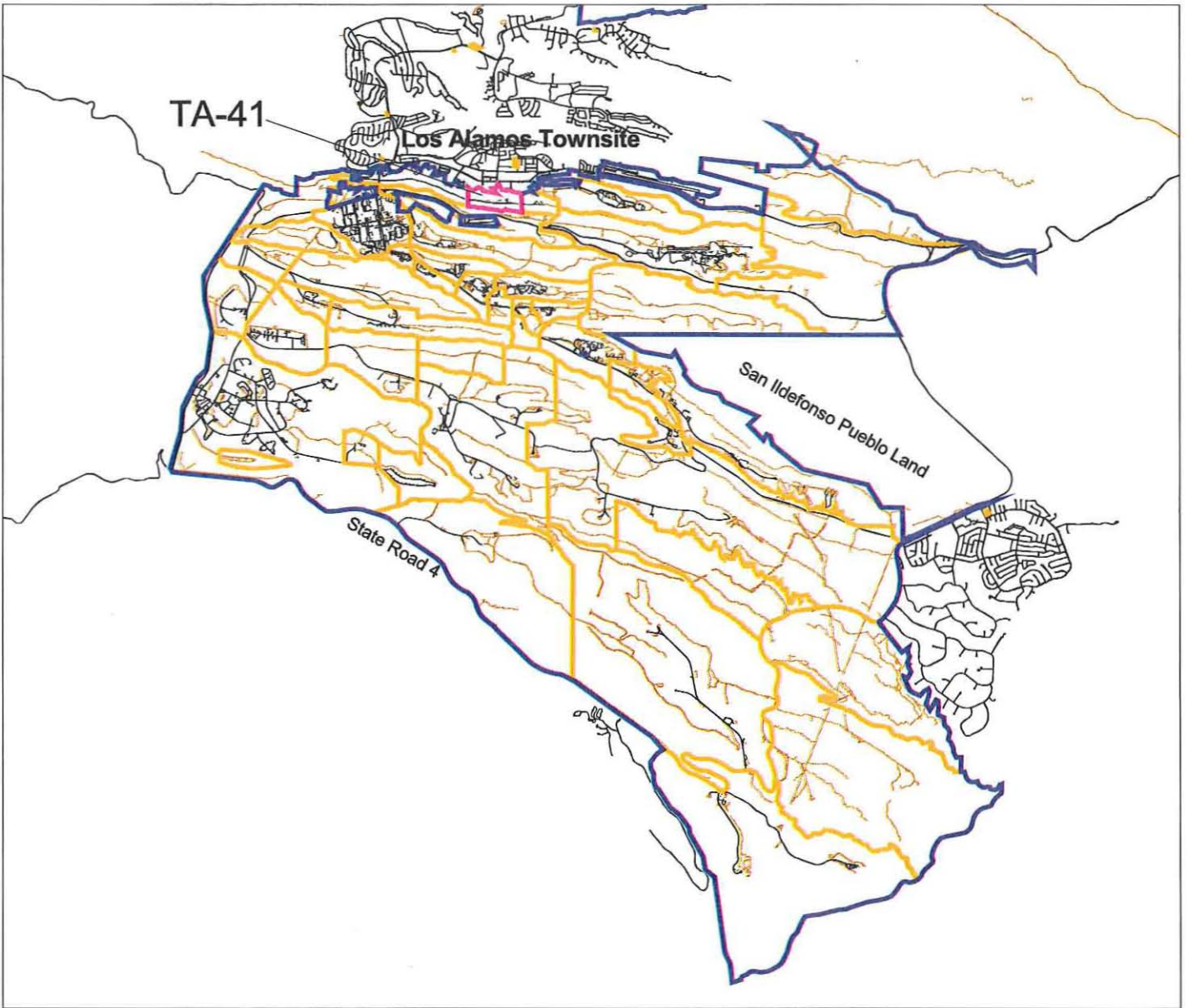

**Los Alamos National Laboratory**  
 Heritage Resources and Environmental Policy Compliance Team  
 RRES-ECO Ecology Group

1:110000

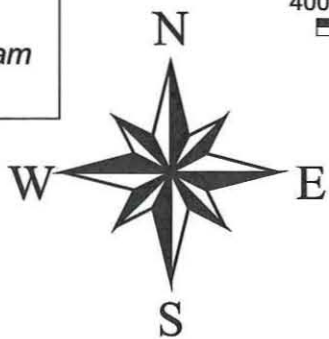
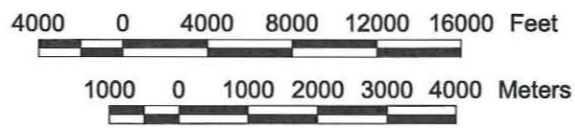

-  Tech Area 41
-  LANL Boundary
-  LANL Tech Area Boundary
-  Roads
-  Roaddirt
-  Parkpave
-  Parkdirt

**TA-41**

Map 1

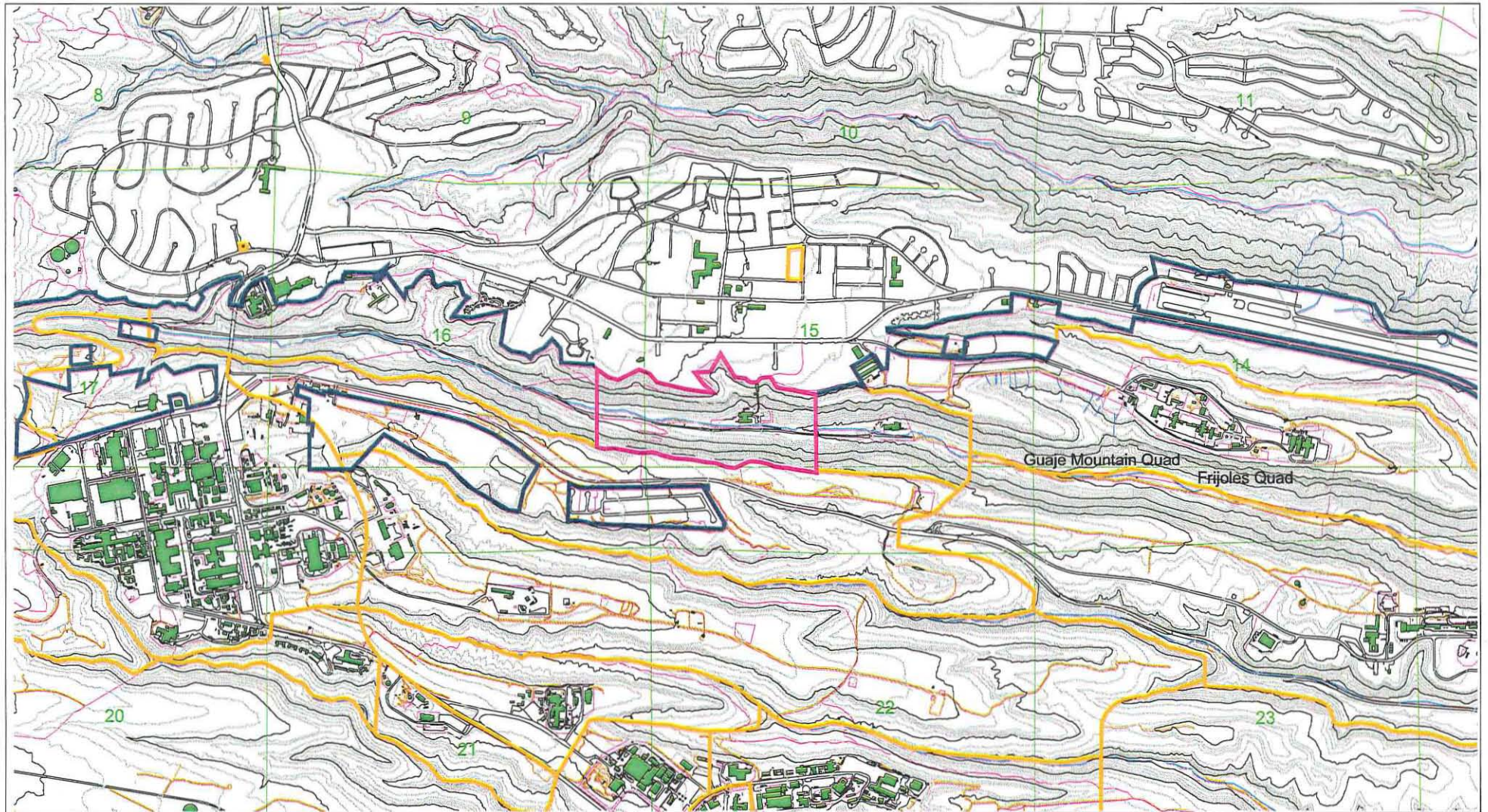

# Los Alamos National Laboratory

Heritage Resources and Environmental Policy Compliance Team  
RRES-ECO (Ecology Group)

TA-41



Map 2

- █ Technical Area 41
- █ LANL Boundary
- █ LANL Technical Areas
- █ Buildings/Structures
- 20 Foot Contours
- 100 Foot Contours
- Drainage
- Township, Section, Range
- USGS 7.5 Minute Quad
- Trails
- Roads
- Road/dirt
- Park/pave
- Park/dirt
- Fences

1:24000

900 0 900 1800 2700 Feet

300 0 300 600 900 Meters



were also retained (Maps 3 and 4).

As per the terms of the MOA, finalized on July 16, 2002, this report includes a history and description of TA-41. Appendices to Volume 1 include historic building inventory forms with representative photographs and building drawings (Appendix A), maps showing TA-41's construction history and the location of eligible and non-eligible properties (Appendix B), oral interview information (Appendix C), and a complete listing of building drawings on file at LANL (Appendix D). A set of indexed archival photographs is included in Volume 2.

## HISTORICAL OVERVIEW

### **Manhattan Project (1942–1946)**

In 1939, Albert Einstein wrote a letter to President Franklin Roosevelt warning him of a possible German atomic bomb threat (Rothman 1992). President Roosevelt, acting on Einstein's concerns, gave approval to develop the world's first atomic bomb and appointed Brigadier General Leslie Groves to head the "Manhattan Project." Groves, in turn, chose Robert Oppenheimer to coordinate the design of the bomb.

A single isolated and secret research facility was proposed. General Groves had several criteria: security, isolation, a good water supply, an adequate transportation network, a suitable climate, an available labor force, and a locale west of the Mississippi located "at least 200 miles from any international border or the West Coast" (Rothman 1992). In 1942, Oppenheimer, who had visited the Pajarito Plateau on a horseback trip, suggested the Los Alamos Ranch School.



**Los Alamos National Laboratory**  
 Heritage Resources and Environmental Policy Compliance Team  
 RRES-ECO (Ecology Group)

**TA-41**  
**Before Demolition**



Map 3

- Buildings/Structures
- Removed Buildings/Structures
- 20 Foot Contours
- 100 Foot Contours
- Techarea
- Drainage
- Township, Section, Range
- USGS 7.5 Minute Quad
- Trails
- Roads
- Roaddirt
- Parkpave
- Parkdirt
- Fences

Guaje Mountain Quad

1:2500

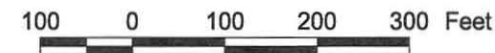



Guaje Mountain Quad

**Los Alamos**  
**National Laboratory**  
*Heritage Resources and*  
*Environmental Policy Compliance Team*  
*RRES-ECO (Ecology Group)*

**TA-41**  
**After Demolition**



Map 4

- Buildings/Structures
- 20 Foot Contours
- 100 Foot Contours
- Techarea
- Drainage
- Township, Section, Range
- USGS 7.5 Minute Quad
- Trails
- Roads
- Roaddirt
- Parkpave
- Parkdirt
- Fences

1:2500

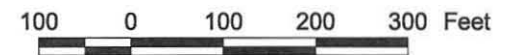

Oppenheimer and his staff moved to Los Alamos in early 1943 to begin work. The recruitment of the country's "best scientific talent" and the construction of technical buildings were top priorities (LANL 1995:8). The University of California agreed to operate the site, code name "Project Y," under contract with the government (an arrangement that has continued to this day). Although the fission bomb was conceptually attainable, many difficulties stood in the way of producing a usable weapon. Technical problems included timing the release of energy from fissionable material and overcoming engineering challenges related to producing a deliverable weapon. Nuclear material and high explosive studies were of immediate importance (LANL 1995).

Two bomb designs appeared to be the most promising: a uranium "gun" device and a plutonium "implosion" device. The gun device involved shooting one subcritical mass of uranium-235 into another at sufficient speed to avoid pre-detonation. Together, the two subcritical masses would form a supercritical mass, which would release a tremendous amount of nuclear energy (Hoddeson *et al.* 1998). This method led to the development of the "Little Boy" device. Because it was conceptually simple, "Little Boy" was never tested before its use at Hiroshima. Scientists were less confident about the implosion design, which used shaped high explosives to compress a subcritical mass of plutonium-239. The symmetrical compression would increase the density of the fissionable material and cause a critical reaction.

In 1944, the uncertainties surrounding the plutonium device necessitated a search for an appropriate test site for the implosion design, later used in the "Fat Man" device. Manhattan Project personnel chose the Alamogordo Bombing Range in south-central New Mexico for the location of the test. A trial run involving 100 tons of trinitrotolulene (TNT) was conducted at the test site ("Trinity Site") on May 7, 1945. This dress rehearsal provided measurement data and simulated the dispersal of radioactive products (LANL 1995). The Trinity test was planned for July and its objectives were "to characterize the nature of the implosion, measure the release of nuclear energy, and assess the damage" (LANL 1995:11). The world's first atomic device was successfully detonated in the early morning of July 16, 1945. Little Boy, the untested uranium gun

device, was exploded over the Japanese city of Hiroshima on August 6, 1945. On August 9, 1945, Fat Man was exploded over Nagasaki, essentially ending the war with Japan.

### **Early Cold War Era (1946–1956)**

The future of the early Laboratory was in question after the end of WWII. Many scientists and site workers left Los Alamos and went back to their pre-war existences. Norris Bradbury had been appointed director of the Laboratory following Oppenheimer's return to his pre-WWII duties (LANL 1993b). Bradbury felt that the nation needed “a laboratory for research into military applications of nuclear energy” (LANL 1993b:62). In late 1945, General Groves directed Los Alamos to begin stockpiling and developing additional atomic weapons (Gosling 2001). Post-war weapon assembly work was now tasked to Los Alamos's Z Division, which had been relocated to an airbase (now Sandia) in nearby Albuquerque, New Mexico (Gosling 2001).

In 1946, Los Alamos became involved in the atmospheric testing program in the Pacific, dubbed “Operation Crossroads.” Later, also in 1946, the U.S. Atomic Energy Commission (AEC) was established to act as a civilian steward for the new atomic technology born of WWII. The AEC formally took over the Laboratory in 1947, making a commitment to retain Los Alamos as a permanent weapons facility.

With the beginning of the Cold War—the term “Cold War” was first coined in 1947—weapons research once again became a national priority. Weapons research at Los Alamos, spearheaded by Edward Teller and Stanislaw Ulam, focused on the development of the hydrogen bomb, the feasibility of which had been discussed seriously at Los Alamos as early as 1946. The simmering Cold War came to a full boil in late 1949 with the successful test of “Joe I,” the Soviet Union's first atomic bomb. In January of 1950, President Truman approved the development of the hydrogen bomb; Truman's decision led to the remobilization of the country's weapons laboratories and production plants. The year 1950 also marked the first meeting of Los Alamos's “Family Committee”—a committee tasked with developing the first two thermonuclear devices (LANL 2001). In 1951, the Nevada Proving Ground (now the Nevada Test Site [NTS]) was established and

the first Nevada atmospheric test, “Able,” was conducted. In the same year, Los Alamos directed “Operation Greenhouse” in the Pacific and successfully conducted both the first thermonuclear test, “George,” and the first thermonuclear “boosted” test, “Item.” In 1952, the first thermonuclear device, known as “Mike,” was detonated at Enewetak Atoll<sup>1</sup> in the Pacific (LANL 1993b). In short order, the Soviet Union responded with a successful demonstration of the use of fusion in August 1953, followed by a test of a hydrogen bomb in 1955. The arms race was on. By 1956, Los Alamos had successfully tested a new generation of high explosives (plastic-bonded explosives) and had begun to make improvements to the primary stage of a nuclear weapon (LANL 2001).

Although weapons research and development has always played a major role in the history of LANL, other key themes for the years 1942–1956 include early advancements in supercomputing, fundamental biomedical research and health physics issues, explosives research and development, early reactor technology, pioneering physics research, and the development of early high-speed photography (McGehee and Garcia 1999). The Early Cold War era at Los Alamos ended in 1956, a date that marks the completion of all basic nuclear weapons design at LANL; later research at Los Alamos focused on the engineering of nuclear weapons to fit specific delivery systems. The year 1956 was also the last year that Los Alamos was a closed facility—the gates into the Los Alamos townsite came down in 1957.

### **Late Cold War Era (1956–1990)**

The Late Cold War era saw Los Alamos’s continued support of the atmospheric testing programs in the Pacific and at NTS. In 1957, the first of many underground tests at NTS was conducted. Other defense mission undertakings during this time included treaty and test ban verification programs (such as using satellite sensors to detect nuclear explosions), research and development of space-based weapons, and continued involvement with stockpile stewardship issues. Non-weapons undertakings supported nuclear medicine, genetic studies, NASA collaborations, superconducting research,

---

<sup>1</sup> A better understanding of the Marshall Islands language has permitted a more accurate transliteration of

contained fusion reaction research, and other types of energy research (McGehee and Garcia 1999).

## HISTORICAL CONTEXT OF TECHNICAL AREA (TA) 41, W SITE (1948–2002)

### **General Overview and Facility Description**

The main period of significance for TA-41 covers the years between 1948 and 1992. Several groups have occupied portions of TA-41 over the years; most, however, were part of W Division, later WX Division. The activities conducted at this technical area directly contributed to Cold War weapons research and development at Los Alamos. Most importantly, the TA-41 facility supported all of the above- and below-ground nuclear tests in which Los Alamos has played a role since the late 1940s. Group responsibilities have encompassed the transportation of components to NTS, gas transfer work involving operations at both TA-33 (Building 33-86) and TA-41, and weapons subsystems design and testing. Weapons subsystems development included work on boosting systems and long-term studies on critical weapons subsystems (U.S. Department of Energy 1986, LANL 1993a:3-10).

Two of the most significant facilities at TA-41, the tunnel and main storage vault (TA-41-1) and the “Ice House” (TA-41-4), provided the DOE with facilities for testing, monitoring, assembling, and storing nuclear weapons components. During the earliest years of the Cold War (circa late 1940s to early 1950s), the nation’s stockpile of nuclear weapons were stored in the TA-41-1 vault and were shuttled back and forth to Sandia Base in Albuquerque (then an airfield under the control of Los Alamos’s Z Division) (Larson 2003). From 1954 to 1973, isotopic analyses of NTS samples containing uranium and plutonium were performed at TA-41. This work was conducted using mass spectrometers located on the bottom floor of TA-41-4 (LANL 1993a). Testing of various types of weapon components using high pressure was conducted at TA-41-4 from 1960 to 2002. High pressure testing and leak testing were performed to determine component integrity and leak rate at elevated internal pressures. Other non-weapon pressure and leak

---

Marshall Island names into English. Enewetak is now the preferred spelling (formerly Eniwetok).

testing was carried out at TA-41 in support of a wide range of Laboratory programs. High pressure and leak determination expertise and technology primarily resided at TA-41 until 2002 (Larson 2002).

### **TA-41 and the Nation's Nuclear Stockpile**

A primary goal of the American nuclear establishment in the early Cold War years was not only to produce more powerful bombs, but also to develop bombs that were more reliable. Immediately after the end of WWII, Los Alamos researchers worked to improve various aspects of the weapons designs used in the Trinity test and over Hiroshima and Nagasaki. For example, both the Little Boy and Fat Man bombs were aerodynamically unstable at high speeds, an instability that could cause the weapons to wobble and miss their targets (Gibson 1996). This post-war weapons engineering and assembly work soon moved out of the confines of Los Alamos to an airbase in nearby Albuquerque, New Mexico.

Sandia Base (later Sandia National Laboratories) began life as part of Los Alamos's wartime operations, later evolving into a separate Cold War installation. Formed in July 1945 as Z-Division within Los Alamos, its primary duties were to perform the ordinance engineering and assembly aspects of Los Alamos's design work (Ullrich 1998). Z-Division was located in Albuquerque because J. Robert Oppenheimer and other Manhattan Project officials realized the need to move some of the weapons production activities to a less isolated area, one preferably near existing military facilities. The desert near Albuquerque was a perfect place for these former Los Alamos operations: Sandia Base was near enough to Los Alamos for scientists to move from one facility to the other fairly quickly and was close enough to Albuquerque to tap into city utilities. Between 1945 and 1947, Z-Division moved its testing, development, and bomb assembly operations to Sandia. As early as 1947, Sandia Base was responsible for military-assisted assembly, testing, and maintenance of the country's atomic weapons. The Mk IV was one of the early production designs. This first-generation atomic device required in-flight assembly and was stored without its nuclear "core." During the late 1940s, the fissile



material for these early types of weapons was stored at Los Alamos. As necessary, Sandia shuttled the nuclear material back and forth from the TA-41 vault. After a few years, Sandia Base built its own fissile material storage area or “Q” area in the nearby Manzano Mountain foothills and discontinued its use of the vault facility at Los Alamos (Larson 2004).

### Weapons Storage Sites and the Role of Black and Veatch

In order to carry out its primary Cold War mission to maintain the capability of launching a nuclear attack, the U.S. government needed a stockpile of weapons with associated storage and assembly sites. These sites came to be known as Q Areas because of the AEC’s stringent security requirements for entry. Sandia controlled the initial management of Q Areas and at least three main stockpile sites were developed by 1950: Site Able in New Mexico (Manzano Base), Site Baker in Texas (Killeen Base) and Site Charlie in Kentucky (Clarksville Base). The Manzano stockpile facility, which would eventually subsume the TA-41 operations, was partially operational by 1949 (Gray *et al.* 1998).

The engineering firm of Black and Veatch of Kansas City designed the primary structures for all of the early Q Areas, including the first stockpile vault structure at TA-41. One of the firm’s partners, Thomas Veatch, was a long time acquaintance of President Harry Truman, and the firm quickly established itself as the leader in the design of special weapons storage facilities during Truman’s post-war years in office.

### **TA-41 and the Development and Testing of the Hydrogen Bomb**

TA-41 also supported the nation’s goals of producing increasingly powerful nuclear weapons, particularly the development of the hydrogen bomb or “Super.” Los Alamos (and specifically TA-41) has had a close relationship with NTS since its origins in the early 1950s. As the race to produce a hydrogen bomb sped forward, TA-41 provided the AEC with facilities for testing, monitoring, assembling, and storing nuclear weapons

components. These capabilities proved very useful once Los Alamos scientists and the American military began testing nuclear devices at Nevada in 1951.

Post-war American nuclear tests took place in the Pacific beginning in 1946 with “Operation Crossroads.” Los Alamos provided the key scientific research for these tests. By the mid 1950s, however, the United States decided to abandon the Pacific tests for several reasons, one of which was the remote nature of the test sites. When the AEC began its search for a continental test site, Los Alamos Director Norris Bradbury indicated his preference for an area northwest of Las Vegas, Nevada, because of its relatively sparse population and flat terrain (Figure 2). In 1950, the AEC chose NTS as the federal government’s nuclear testing ground (Fehner and Gosling 2002). During the early 1950s, NTS essentially operated as a testing ground for Los Alamos nuclear designs. Los Alamos officials pressed for the site, Los Alamos scientists developed the weapons and conducted the tests, and Los Alamos workers analyzed samples taken after the tests.

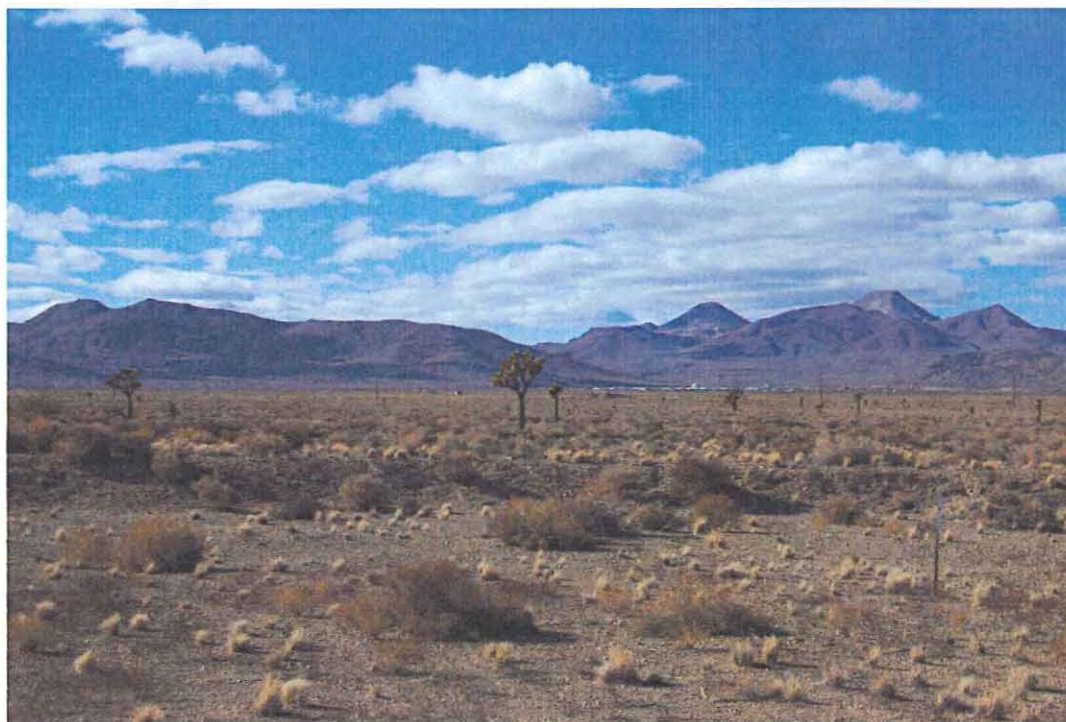

(LANL, RRES-ECO/HREPC, #DCP\_0229)

Figure 2. Nevada Test Site

Between 1951 and 1992, the United States conducted 928 tests at the Nevada facility (Fehner and Gosling 2002). TA-41 played an important role in many of these tests. TA-41 personnel developed components that were used in both above- and below-ground tests, and scientists who worked at TA-41 also traveled to Nevada to participate in the actual shots (Figure 3).

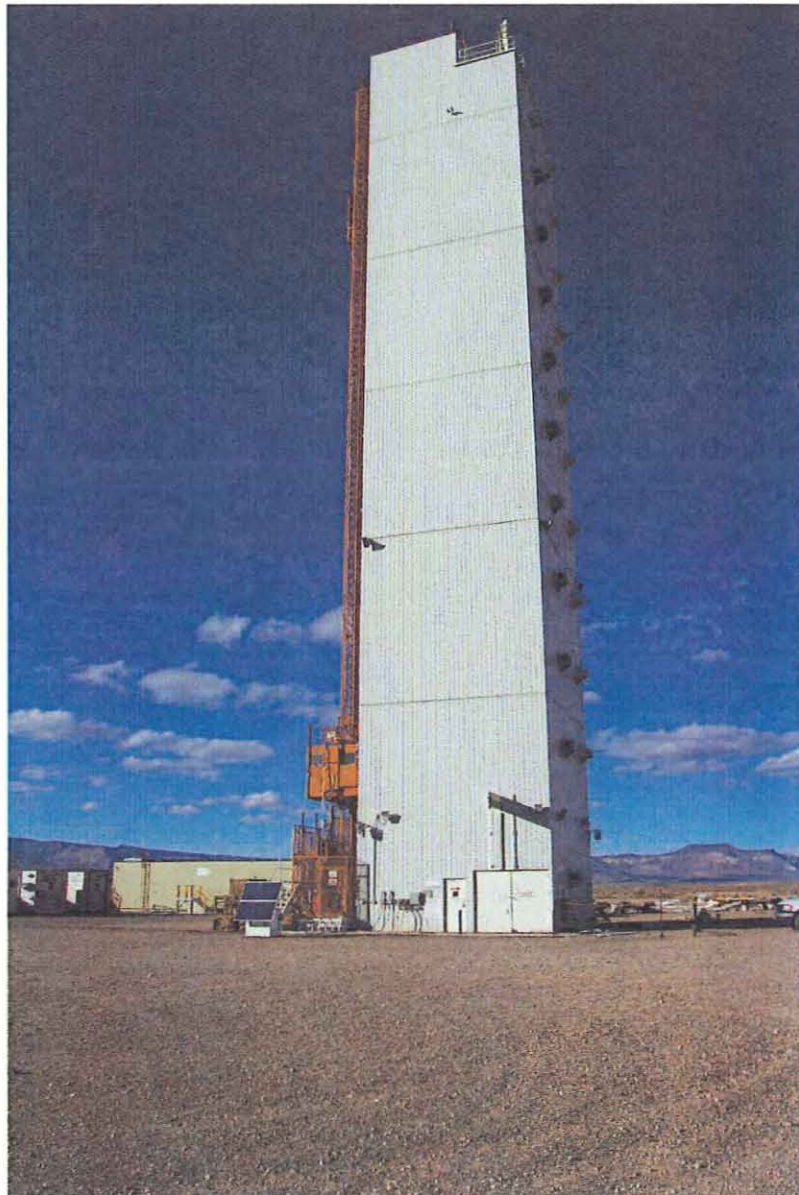

(LANL, RRES-ECO/HREPC, #DCP\_0254)

Figure 3. "Icecap" Aboveground Test at NTS (Joint Los Alamos and British Test)

## TA-41 and the Gas Handling Facility at TA-33

At Los Alamos, TA-41 operations were closely linked to tritium operations at TA-33. TA-33-86, the Gas Handling Facility, began operations in June of 1955. It was the first facility at LANL to handle larger quantities of tritium gas for Los Alamos's nuclear weapons development program. Workers at the Gas Handling Facility repacked the gas into small-volume high-pressure vessels or "gas containers" that were used in several weapons systems and devices tested at NTS (Ziemer 1991, Estrada 1998). Gas transfer work at TA-33 directly supported operations at TA-41 and the same W Division employees worked at both facilities (Larson 2003).

## **The Icehouse – TA-41-4**

During the period of Nevada testing, 30 to 35 people worked in the icehouse, producing one shot a month. The north portion of the icehouse and the vault had restricted access, and for this reason, an icehouse exclusion zone was established, complete with a guard checkpoint on the inside of the building. The north wing of the icehouse building was assembly space: the south half of the wing was used for production and the north half was used for inspection. Room 244, the "low-interference count room," is located at the end of the icehouse's tunnel addition and contains a balance block and two balances. The older balance weighed all of Los Alamos's Nevada and Pacific shots (Figure 4). The balance was moved to the icehouse from a Ranch School-era icehouse building at Ashley Pond. The original icehouse (TA-41-4's namesake) stored plutonium and enriched uranium and was used as an assembly area during the Manhattan Project and early Cold War years. The original icehouse door was brought to TA-41 and used on the day vault inside TA-41-4 (Figure 5). The door was later sent to the salvage yard but the lock and handle have been saved (Larson 2001).

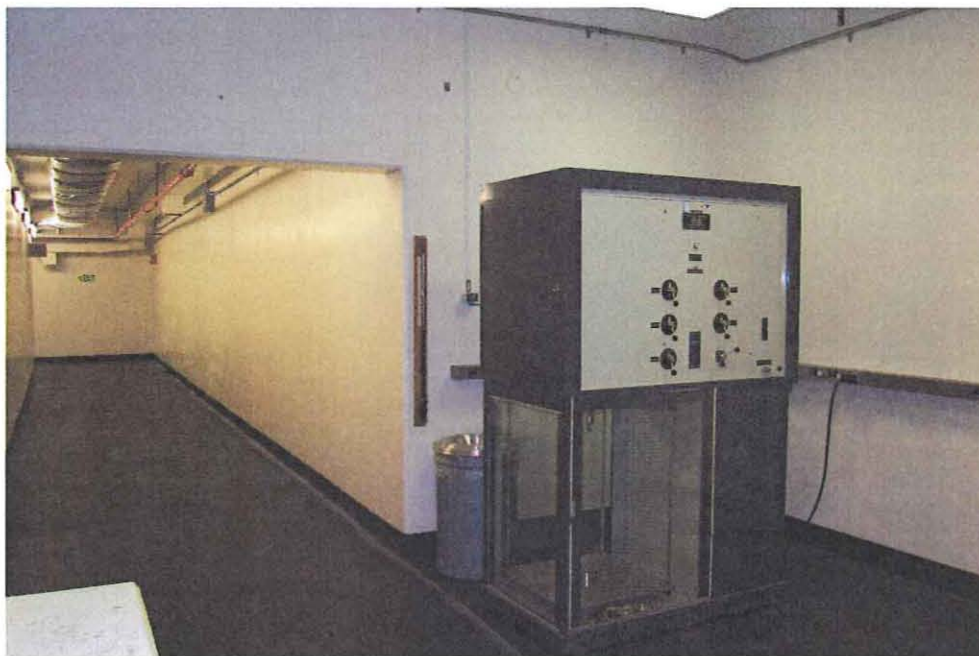

(LANL, RRES-ECO/HREPC, #DCP\_0834)

Figure 4. Room 244 and the Older Balance, December 2001

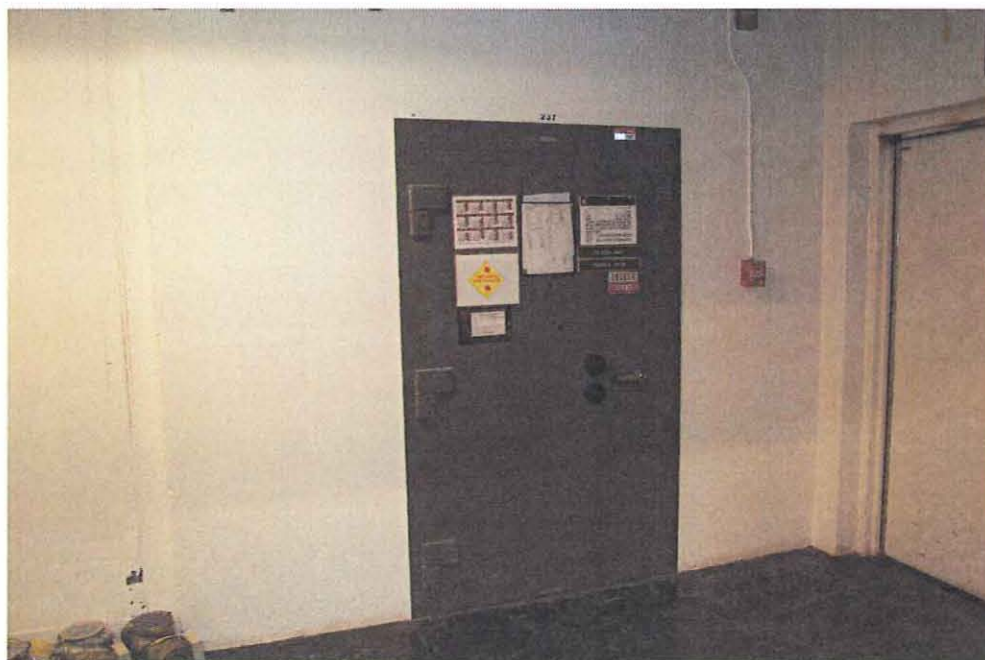

(LANL, RRES-ECO/HREPC, #DCP\_0838)

Figure 5. Day Vault in Building TA-41-4 (with new door), December 2001

The “Annex,” located on the west side of the north wing, was used for high pressure testing. The pressure compressors for the high pressure testing cells are located in the

Annex, in an adjacent room to the pressure vessels (Figure 6). Rectangular pressure vessels were called “coffins” and spherical ones were given the name “blue balls” (Figure 7).



(LANL, RRES-ECO/HREPC, #DCP\_0851)

Figure 6. Pressure Compressors in the Annex, December 2001

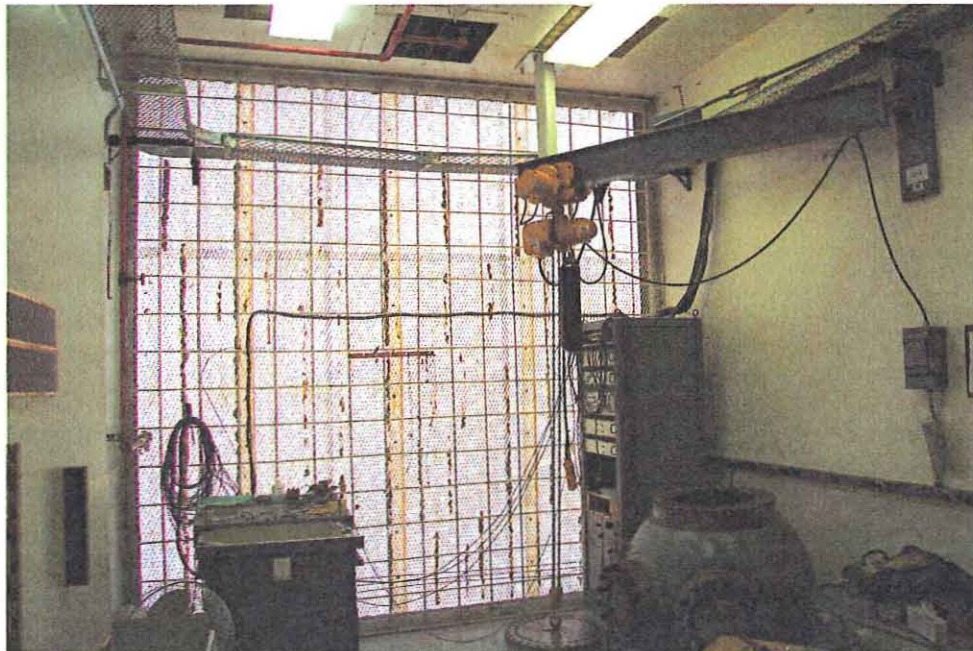

(LANL, RRES-ECO/HREPC, #DCP\_0852)

Figure 7. Pressure Vessels – “Coffin” (at left) and “Blue Ball” (at right), December 2001

### The Tunnel – TA-41-1

The tunnel is lined with concrete and extends approximately 250 feet into the north side of Los Alamos Canyon. The tunnel complex is more than 6,000 square feet in size, and the main tunnel corridor was designed to be large enough to accommodate a delivery vehicle. The tunnel and vault were built to replace the D Site Vault at TA-26 and also to take on the storage functions of the original icehouse at the pond (Figure 8). TA-26 was located along the main road to Los Alamos, east of the airport area near the East Gate. Facilities included several standard guard towers and a concrete vault for storing nuclear material (LASL 1964) (Figure 9).

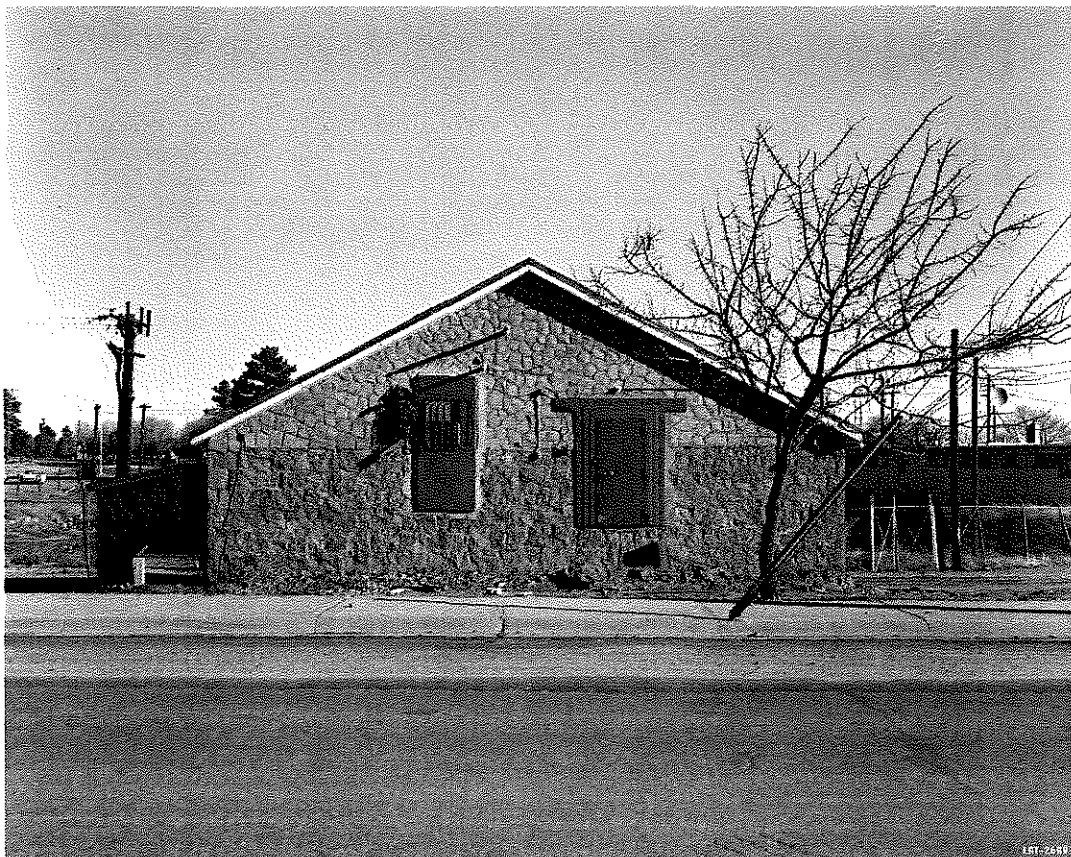

(LANL, IM-9 Photography, #LAT-2689)

Figure 8. The Original Icehouse Building

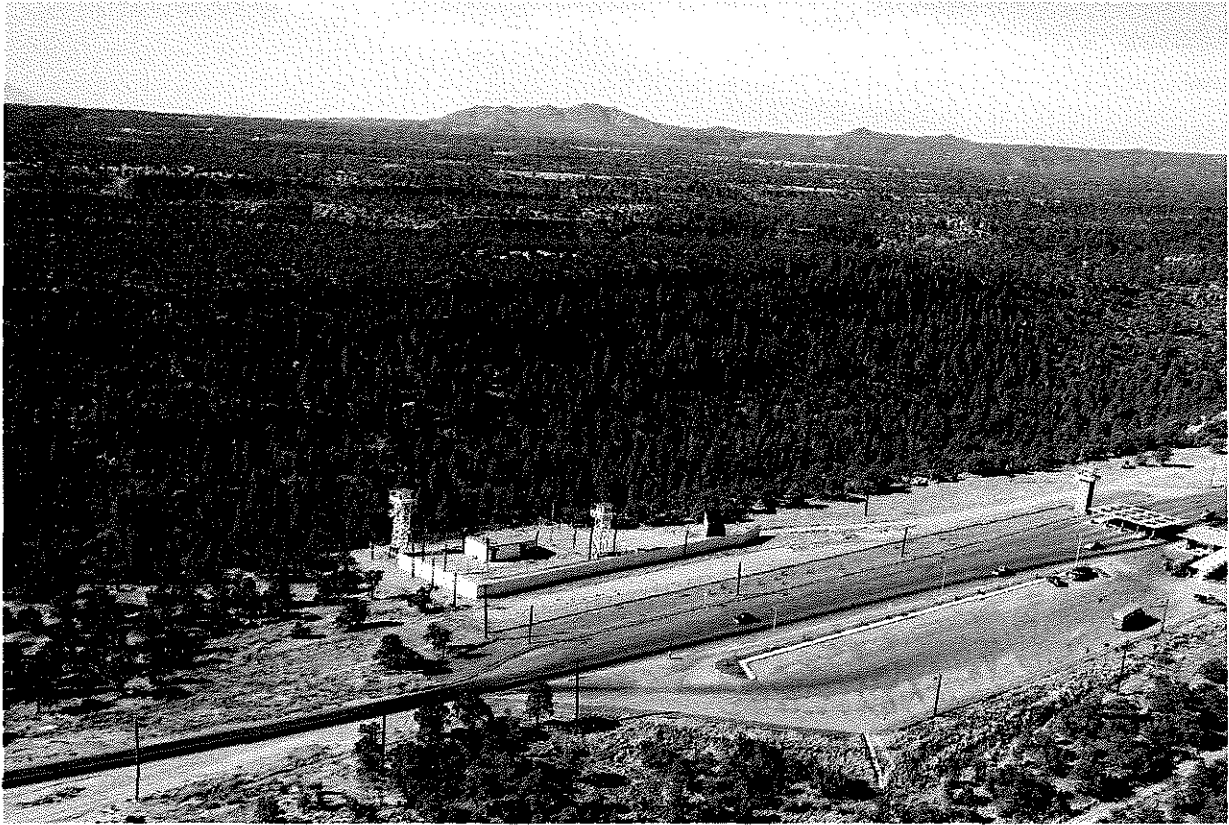

(LANL, IM-9 Photography, #15924)

Figure 9. TA-26 and the D Site Vault, 1950

The new tunnel and vault at TA-41 took almost a year to build (it was under construction from June 1948 to May 1949). It was designed to have controlled humidity (around 50 percent) and temperature (between 40 and 60 degrees) with redundant sources of light and power, including an emergency battery supply and a standby diesel-powered electric generator. The tunnel and vault area, along with associated security features and a new guard station, cost about \$500,000 to build (LASL 1964) (Figure 10).



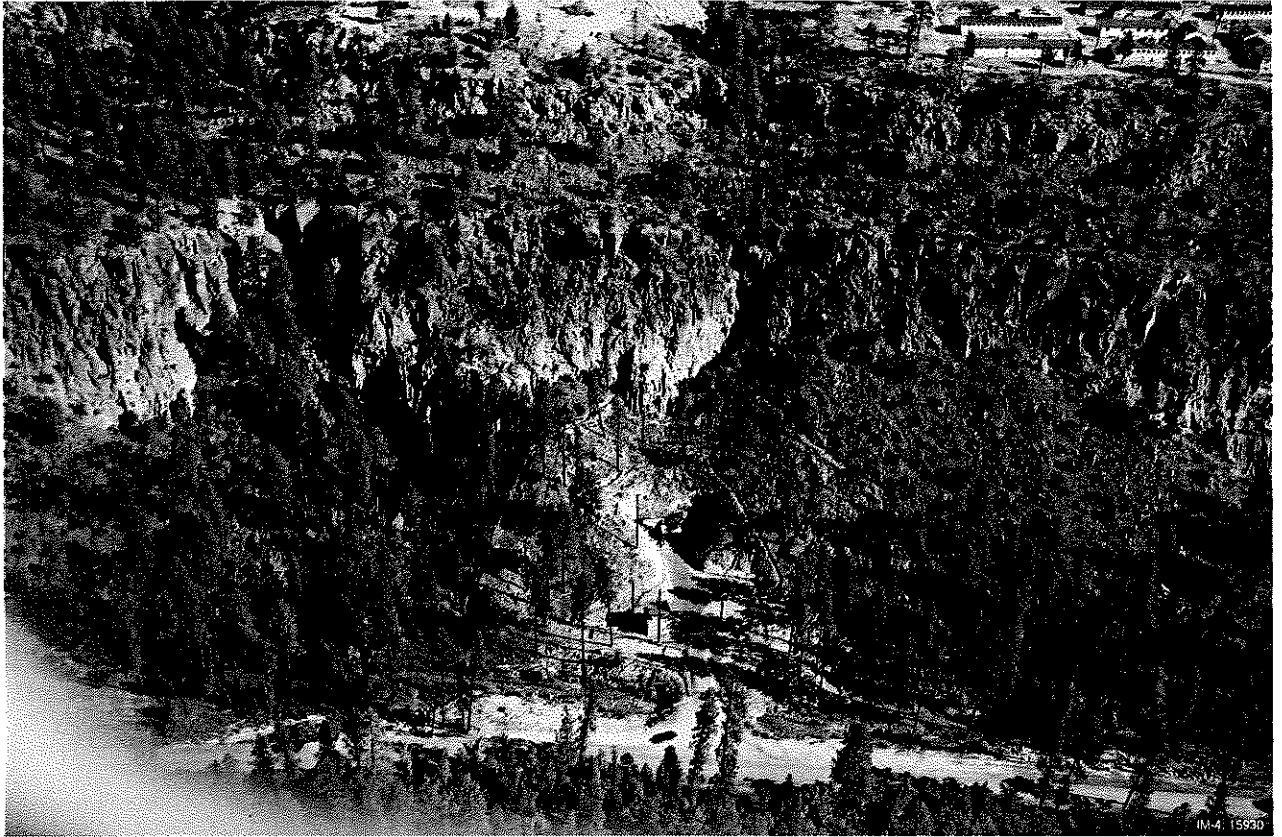

(LANL, IM-9 Photography, #15930)

Figure 10. TA-41-1 (vault) and TA-41-2 (guard house), circa 1950

A locked vault area is located at the end of the main tunnel passageway. Individual walk-in vaults are located inside the main bank vault-type door (Figure 11). Each walk-in vault, in turn, can be kept locked for additional access control (LASL 1964).



(LANL, IM-9 Photography, #PUB-5936-007)

Figure 11. Main Vault Door and Interior Walk-In Vaults

Both TA-41-4 (the ice house) and TA-41-1 (the tunnel and vault) were designated as fallout shelters; the shelter area in the tunnel could support over 200 people for two weeks (Larson 2001 and LASL 1964). The tunnel corridor and rooms are well shielded against naturally occurring background radiation making it a desirable location for pure physics experiments (LASL 1964) (Figure 12). Initial experiments associated with Frederick Reines and Clyde Cowan's Nobel Prize winning neutrino research were conducted in the tunnel passageway for this very reason (Plassmann 2003).

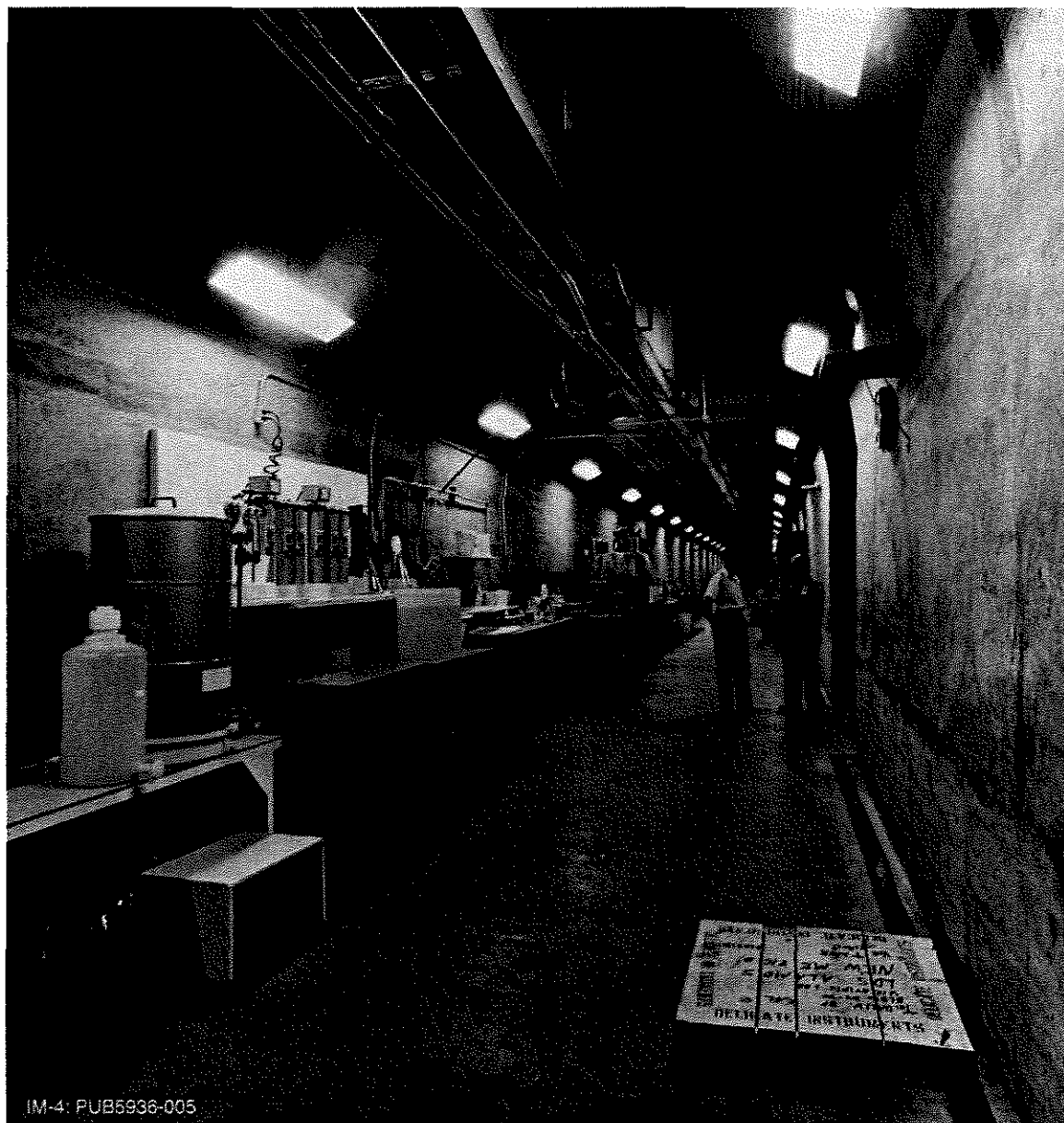

(LANL, IM-9 Photography, #PUB-5936-005)

Figure 12. The Main Tunnel Corridor

### Los Alamos Neutrino Experiments

In 1951, Reines and Cowan began experimenting at Los Alamos with the goal of observing neutrinos, a type of fundamental particle with no electric charge and little or no mass. Before Reines and Cowan began their study of the neutrino (a study they dubbed “Project Poltergeist”), other scientists had only hypothesized its existence. However, the

advent of neutrino sources, such as fission bombs and reactors, opened up greater possibilities for detection (LANL 1997).

The work of Reines and Cowan is an excellent example of the collaborative nature of the work done within the country's complex of national laboratories. The two scientists began their work at Los Alamos's TA-41, using the tunnel and vault at TA-41-1 because the facility was well shielded from background radiation that could skew the results of their experiments. After a year of research at Los Alamos, Reines and Cowan decided that using a fission reactor was the best way to observe neutrinos. They moved their research to Hanford in Washington and began to see preliminary results. In 1953, they learned of a new reactor being built at the Savannah River site in South Carolina and ultimately moved their experiments there in 1955. One year later, in 1956, Reines and Cowan observed the neutrino and proved its existence (The Nobel Foundation 2004).

Reines and Cowan soon parted ways. Cowan left Los Alamos once the neutrino experiments were finished. Reines left in 1959, choosing to continue his work with neutrinos at Savannah River. Cowan died in 1974 after serving as a professor at the Catholic University of America and a consultant to the United States Naval Academy and the AEC, among other agencies. Reines went on to win the Nobel Prize in Physics in 1995 for his lifelong experiments with neutrinos, including those done with Clyde Cowan. Frederick Reines died in 1998 (The Nobel Foundation 2004).

## DESCRIPTION OF MOA PROPERTIES

### Building Identification and Numbering

The buildings discussed in this report are identified using the current LANL system of placing the TA prefix before each building number. Historically, however, the “W” prefix was used before each building number and some of the drawings included in this report may use the old system of building identification. For example, TA-41-4 is the same building as W-4.

#### TA-41-1 (and TA-41-3)

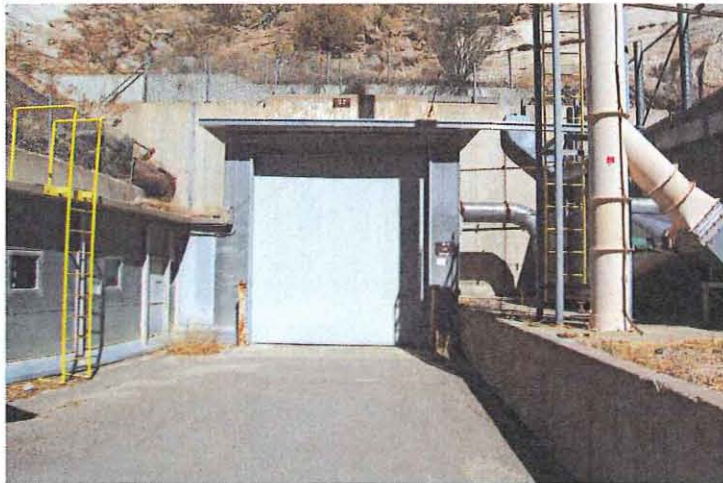

(LANL, RRES-ECO/HREPC, #DCP\_1108)

TA-41-1 Vault, South Elevation, March 2002

TA-41-1 is a unique tunnel and vault facility and is one of the best examples of Cold War architecture at Los Alamos. TA-41-1 was built between 1948 and 1949, at the beginning of the Cold War era. It was designed in 1948 by Black and Veatch Consulting Engineers of Kansas City, Missouri and built by Brown and Root, Inc. of Houston, Texas (LANL 1993a:3-10). The vault functioned as a storage facility for nuclear components and nuclear material. It was originally designed to replace a smaller nuclear storage vault at former TA-26, located near the East Gate entrance to Los Alamos (LASL 1964).

The TA-41-1 tunnel and vault is a reinforced concrete structure. The tunnel penetrates 230 feet into the north wall of Los Alamos Canyon through a concrete portal and secure overhead door. The vault consists of five concrete rooms within a larger room at the end of the tunnel. The tunnel is vented and the original inlet pipe and secure vent structure (TA-41-3) is visible on the hillside adjacent to the entrance.



(LANL, RRES-ECO/HREPC, #DCP\_1098)

TA-41-3 Blower House Air Intake, South Elevation, March 2002

## TA-41-2

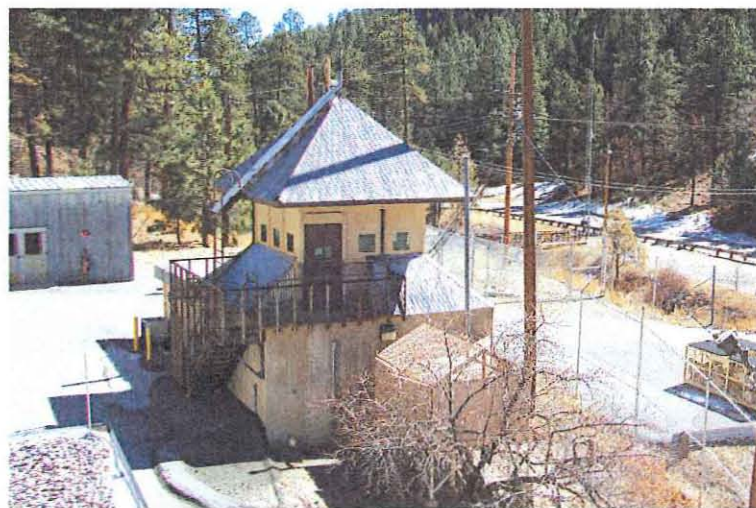

(LANL, RRES-ECO/HREPC, #DCP\_1115)

TA-41-2, Guard Station, North and West Elevations, March 2002

TA-41-2 was constructed during 1948 to 1949. This guard station supported the extensive security protocols in effect at TA-41. TA-41-2 represents a unique architectural style based on functions performed within and around the facility. It provides protection for personnel working within the facility and an elevated vantage point for observing and enforcing a security perimeter. The facility is a cast-in-place reinforced concrete structure. The original roof was flat concrete with built up roofing. Subsequently, a sloped metal roof was added for the express purpose of preventing objects such as satchel charges from being placed on the roof—the slope is such that objects will slide off.

**TA-41-4  
(and TA-41-6 and TA-41-47)**

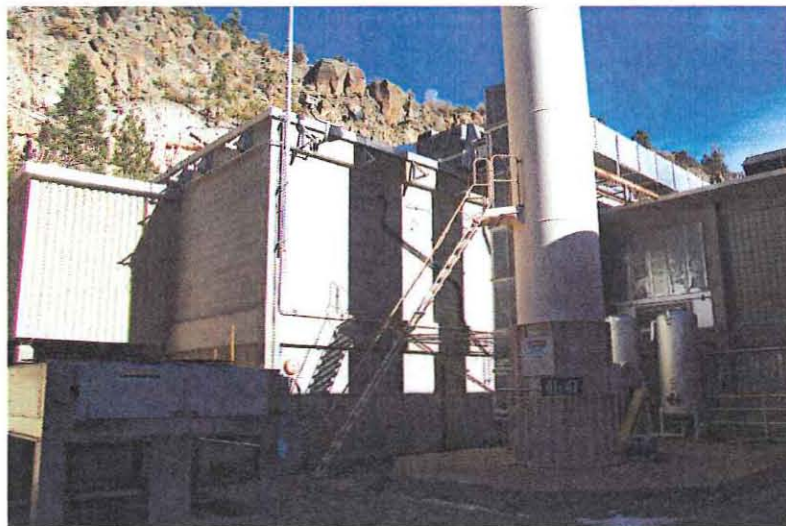

(LANL, RRES-ECO/HREPC, #DCP\_0770)

TA-41-4 Laboratory and Office Building, South Elevation of North Wing, December 2001

TA-41-4, the “Ice House,” was built between 1950 and 1951. It was named after the Los Alamos Ranch School’s icehouse, which was located in downtown Los Alamos. During World War II, the icehouse at Ashley Pond was used to store plutonium and enriched uranium, and functioned as an area for the assembly of weapon components.

The TA-41 “Ice House” is a two level, flat-roofed structure with laboratory and high bay areas. The building is a cast-in-place reinforced concrete post and beam structure. A unique architectural feature is located within the canyon wall along the north side of the

building: a concrete tunnel leading to a low-interference count room. The Ice House also contains an addition known as the “Annex,” completed in 1959. The Annex contains laboratories and areas for over-pressure experiments. This area has reinforced concrete walls and doors, shatter proof observation windows, and unique equipment to support experimentation. A tall exhaust stack (TA-41-47) was built to support the activities conducted in the Annex.

A curved corridor, TA-41-6, connects the Ice House building to the main storage vault. It was built at the same time as TA-41-4 and is actually an extension of that building. The corridor’s outside wall is constructed of steel frame and light-gauge steel panels. The inside wall, which also serves as a retaining wall against the north face of the canyon, is reinforced concrete.



(LANL, RRES-ECO/HREPC, #DCP\_1093)

TA-41-6 Passageway, Connecting Building TA-41-4, on left, to Building TA-41-1, South Elevation, March 2002

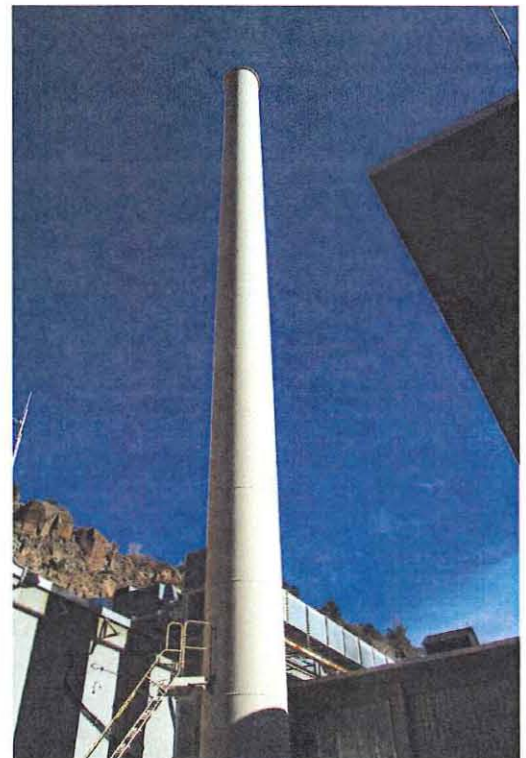

(LANL, RRES-ECO/HREPC, #DCP\_0771)  
TA-41-47, Exhaust Stack, 2002

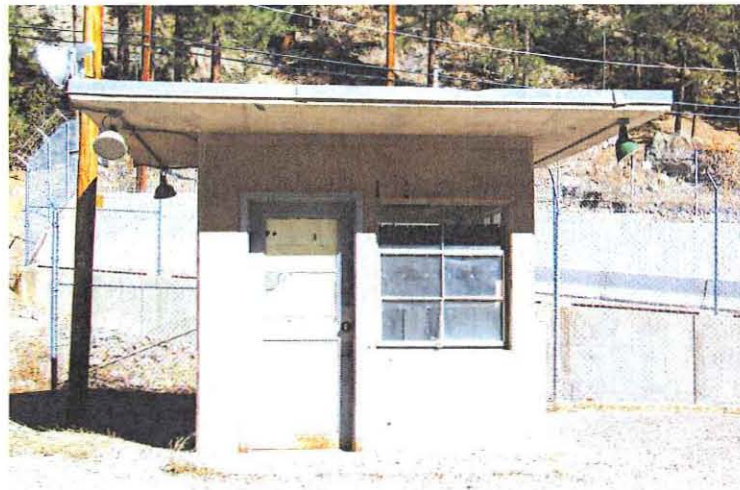

**TA-41-16**

(LANL, RRES-ECO/HREPC, #DCP\_1077)

TA-41-16 Guard Station, South Elevation, March 2002

TA-41-16 is a guard station that was built in 1952 by the Claremont Construction Company. The building, “Station 207,” is small (only 87 ft<sup>2</sup> in size), has a flat roof, and is constructed of cast-in-place concrete. TA-41-16 supported the perimeter security of the entire TA-41 facility, serving as an access checkpoint.

## REFERENCES CITED

- Estrada, J.  
1998 "Interview Notes on TA-33-86." Commodore Advanced Sciences, Inc. Memorandum regarding interview with John Dougherty, dated September 17, 1998, to Kari Manz, ESH-20, Los Alamos National Laboratory, on file at RRES-ECO, Los Alamos National Laboratory, Los Alamos, New Mexico.
- Fehner, T. R. and F. G. Gosling  
2002 *Origins of the Nevada Test Site*. United States Department of Energy, DOE/MA-0518.
- Gibson, J. N.  
1996 *Nuclear Weapons of the United States: An Illustrated History*. Schiffer Publishing Ltd., Atglen, Pennsylvania.
- Gosling, F. G.  
2001 *The Manhattan Project: Making the Atomic Bomb*. U.S. Department of Energy, DOE/MA-0002.
- Gray, A., D. Humpf, and K. Mitchell  
1998 *Architectural Survey of the Proposed National Guard Complex on Clarksville Base, Montgomery County, Fort Campbell, Kentucky*. Environmental Division, Conservation Branch, Fort Campbell, Kentucky. Copy on file at RRES-ECO, Los Alamos National Laboratory, Los Alamos, New Mexico.
- Hoddeson, L., P. W. Henriksen, R. A. Meade, and C. Westfall  
1998 *Critical Assembly: A Technical History of Los Alamos during the Oppenheimer Years, 1943-1945*. Cambridge University Press, New York and Cambridge.
- LANL (Los Alamos National Laboratory)  
1993a *RFI Work Plan for Operable Unit 1098: Environmental Restoration Program*, LA-UR-92-3825, Los Alamos National Laboratory, Los Alamos, New Mexico.
- 1993b *Los Alamos: Beginning of an Era, 1943-1945*. Reprinted by the Los Alamos Historical Society, Los Alamos, New Mexico.
- 1995 Los Alamos National Laboratory: A Proud Past, An Exciting Future (Special Issue), LALP-95-2-6&7. *Dateline: Los Alamos*.
- 1997 The Reines-Cowan Experiments-Detecting the Poltergeist. In *Los Alamos Science*.

- 2001 *The Laboratory in a Changing World: A Los Alamos Chronology; LALP-01-65.* The Nuclear Weapons Publication Team, Los Alamos National Laboratory, Los Alamos, New Mexico.

Larson, R.

- 2001 Notes taken by K. Garcia from 12/12/01 walkthrough with Richard Larson at TA-41. On file at RRES-ECO, Los Alamos National Laboratory, Los Alamos, New Mexico.
- 2002 Personal communication via email. "Re: another question about TA-41," Larson to K. Garcia, 4/22/02, on file at RRES-ECO, Ecology Group, Los Alamos National Laboratory, Los Alamos, New Mexico.
- 2003 Interview with John Ronquillo and Ellen McGehee. Recording of August 8, 2003 interview with Richard Larson on file at RRES-ECO, Los Alamos National Laboratory, Los Alamos, New Mexico.
- 2004 Personal communication. R. Larson to E. McGehee, September 2004.

LASL (Los Alamos Scientific Laboratory)

- 1964 *The Atom.* Volume 1, Number 11. Los Alamos Scientific Laboratory, Los Alamos, New Mexico, November 1964.

McGehee, E. D. and K. L. M. Garcia

- 1999 *Historical Building Assessment for the Department of Energy Conveyance and Transfer Project.* Historic Building Survey No. 178, LA-UR-00-1003. On file at RRES-ECO, Los Alamos National Laboratory.

The Nobel Foundation

- 2004 *Frederick Reines – Autobiography.* Accessed 2004. Available from <http://nobelprize.org/physics/laureates/1995/reines-autobio.html>.

Plassmann, E.

- 2003 Interview with John Ronquillo and Ellen McGehee. Recording of August 11, 2003 interview with Elizabeth "Beth" Plassmann on file at RRES-ECO, Los Alamos National Laboratory, Los Alamos, New Mexico.

Rothman, H.

- 1992 *On Rims and Ridges, The Los Alamos Area Since 1880.* University of Nebraska Press, Lincoln, Nebraska.

Ullrich, R.

- 1998 *Tech Area II: A History.* Sandia National Laboratories, SAND98-1617.

U.S. Department of Energy

1986 *Phase 1: Installation Assessment, Los Alamos National Laboratory, Comprehensive Environmental Assessment and Response Program [CEARP] (Working Draft)*. Albuquerque Operations Office, Albuquerque, New Mexico. On file at RRES-ECO, Los Alamos National Laboratory, Los Alamos, New Mexico.

Ziemer, P. L.

1991 "National Environmental Policy Act (NEPA) Determination for the Deactivation, Disassembly, and Decontamination of Building 86 at TA-33 at the Los Alamos National Laboratory (LANL)." Department of Energy Memorandum dated November 14, 1991, from Assistant Secretary, Environment, Safety and Health (EH-25) to Richard A. Claytor, Assistant Secretary for Defense Programs, Washington D.C.

**Appendix A: Historic Building Inventory Forms with  
Representative Photographs and Building Drawings**

LANL TA- Building # 41-0001

Camera 984242

Frame #s DCP\_1111 through DCP\_1113

Surveyor(s) J.Ronquillo/K.Towery

Date 01/17/2002

Los Alamos National Laboratory CRMT Historic Building Survey Form

Building Name Underground Vault UTMs easting 382951 northing 3970987 zone 13

Legal Description: Map Guaje Mountain Quad 1984 tns 19N range 6E sec 15

Current Use/ Function Underground Vault Original Use/ Function Underground Vault

Date (estimated) 1950 Date (actual) 1949 Property Type Security

Type of Construction

Pre-Fabricated Metal [ ] Steel Frame [ ] Wood Frame [ ] CMU [ ] Reinforced Concrete [x]

Other Type of Construction Concrete Moment Frame. # of Stories 1

Foundation Reinforced Concrete.

Exterior CMU-Exterior [ ] Reinforced Concrete-Exterior [x] Steel (galvanized) [ ] Steel (corrugated) [ ]

Wood Siding [ ] Asbestos Shingles-Exterior [ ] In-Fill Panels [ ] Other-Exterior [ ]

Exterior Treatment (painted, stuccoed, etc) Reinforced, vault type building.

Exterior Features (docks, speakers, lights, signs, etc) The south entrance contains one large overhead coiling door leading into the passageway. Mechanical equipment and a large stack are located to the right of the door.

Addition CMU-Addition [ ] Reinforced Concrete-Addition [ ] Steel (galvanized)- Addition [ ] Wood [ ]

Steel (corrugated)-Addition [ ] Asbestos Shingles-Addition [ ] Other- Addition [ ]

Exterior Treatment-Addition [ ]

Exterior Features-Addition [ ]

Roof Form Slanted/Shed [ ] Gable [ ] Other Roof Type Barrel Vault reinforced concrete.

Degree of Pitch/ Slope Underground

Roof Materials Corrugated Metal [ ] Rolled Asphalt [ ] Asbestos Shingles [ ] 4-Ply Built Up [ ]

Other Roof Materials Reinforced concrete.

Window Type Casement [ ] Single Hung Sash [ ] Double Hung Sash [ ] Fixed Window [ ]

Other Window Type N/A

# of Each Window Type/ Comments [ ]

Glass Type Clear [ ] Wire Glass [ ] Opaque [ ] Painted Glass [ ] Glass Block [ ]

Light Pattern N/A

**Door Type**

Personnel Door Types	Exterior	Fire Door <input type="checkbox"/>	Single <input type="checkbox"/>	Double <input type="checkbox"/>	Roll-up <input type="checkbox"/>	Sliding <input type="checkbox"/>
		Hollow Metal <input type="checkbox"/>	Solid Wood <input type="checkbox"/>	1/2 Glazed <input type="checkbox"/>	Paneled <input type="checkbox"/>	Louvered <input type="checkbox"/>
	Interior	Fire Door <input type="checkbox"/>	Single <input type="checkbox"/>	Double <input type="checkbox"/>	Roll-up <input type="checkbox"/>	Sliding <input type="checkbox"/>
		Hollow Metal <input type="checkbox"/>	Solid Wood <input type="checkbox"/>	1/2 Glazed <input type="checkbox"/>	Paneled <input type="checkbox"/>	Louvered <input type="checkbox"/>
Equipment Door Types	Exterior	Fire Door <input type="checkbox"/>	Single <input type="checkbox"/>	Double <input type="checkbox"/>	Roll-up <input type="checkbox"/>	Sliding <input type="checkbox"/>
		Hollow Metal <input type="checkbox"/>	Solid Wood <input type="checkbox"/>	1/2 Glazed <input type="checkbox"/>	Paneled <input type="checkbox"/>	Louvered <input type="checkbox"/>
	Interior	Fire Door <input type="checkbox"/>	Single <input type="checkbox"/>	Double <input type="checkbox"/>	Roll-up <input type="checkbox"/>	Sliding <input type="checkbox"/>
		Hollow Metal <input type="checkbox"/>	Solid Metal <input type="checkbox"/>	1/2 Glazed <input type="checkbox"/>	Paneled <input type="checkbox"/>	Louvered <input type="checkbox"/>

# of Each Door Type/Comments: One large overhead coiling door at south entrance to storage vault.

**Interior Wall**

Gypsum Board  Reinforced Concrete- Interior

CMU- Interior  Plywood  Other- Interior

In-Wall Electrical Wiring  On-Wall Electrical Wiring

**Ceiling** Drop Ceiling

Interior Comments (Equipment, etc)

**Degree of Remodeling**

**Condition** Excellent  Good  Fair  Deteriorating  Contaminated  Burned

**Associated Building**

If yes, list building names and #s: TA-41-6 is a covered passageway. It leads to & connects TA-41-1 to TA-41-4. TA- 41-3, a small blower house is located on the hill above TA-41-1. TA-41-3 has a metal louvered grill with man guards and access door.

**Integrity** Excellent

**Significance** Eligible

**Eligible Under Criterion** A  B  C  D  Not Eligible

**DOE Themes**

Nuclear Weapon Components and Assembly  Nuclear Weapon Design and Testing  Nuclear Propulsion

Peaceful Uses: Plowshare, Nuclear Medicine, Nuclear Energy, Nuclear Science  Energy and Environment: Research Design Projects

**LANL Themes**

Weapons Research and Design, Testing, and Stockpile Support  Super Computing

Reactor Technology  Biomedical/Health Physics  Strategic and Supporting Research

Environment/Waste Management  Administration and Social History  Architectural History

**Recommendations/ Additional Comments**

TA-41-3, a Blower House, is located on the hill above TA-41-1, a vault. Air is transferred via 16" diameter pipe to TA-41-1. The blower house is approx. 13 gross square feet. UTM coordinates are midpoint in the actual vault room.

**Architectural Features (elevations)**

The only visible architectural feature is a large overhead coiling door. The rest of the vault is located underground.

**Total sq ft** 7,267 Gross

**Architect/ Builder**

Contractor: Brown & Root

**Alterations**

**List of Drawings (Cntrl + Enter for para break)**

ENG-C 1581  
Sheet 7 of 34  
W-Site, Explosive Storage, TA-41  
Plans and Sections (W-1)  
January 12, 1948

ENG-C 1582  
Sheet 8 of 34  
W-Site, Explosive Storage, TA-41  
Elevations & Sections (W-1)  
January 12, 1948

ENG-AB 111  
Underground Vault  
TA-41, Bldg. 1  
Floor Plan  
June 7, 1993



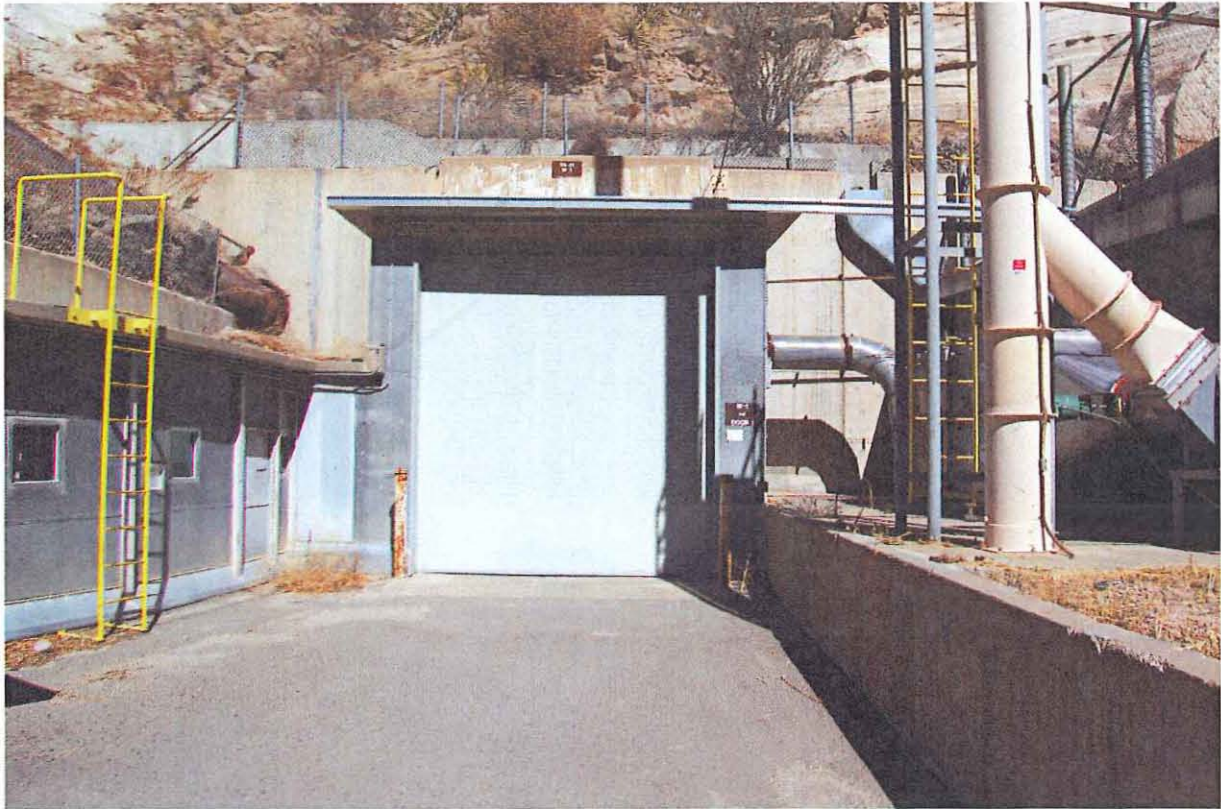

TA-41-1 Vault, South Elevation

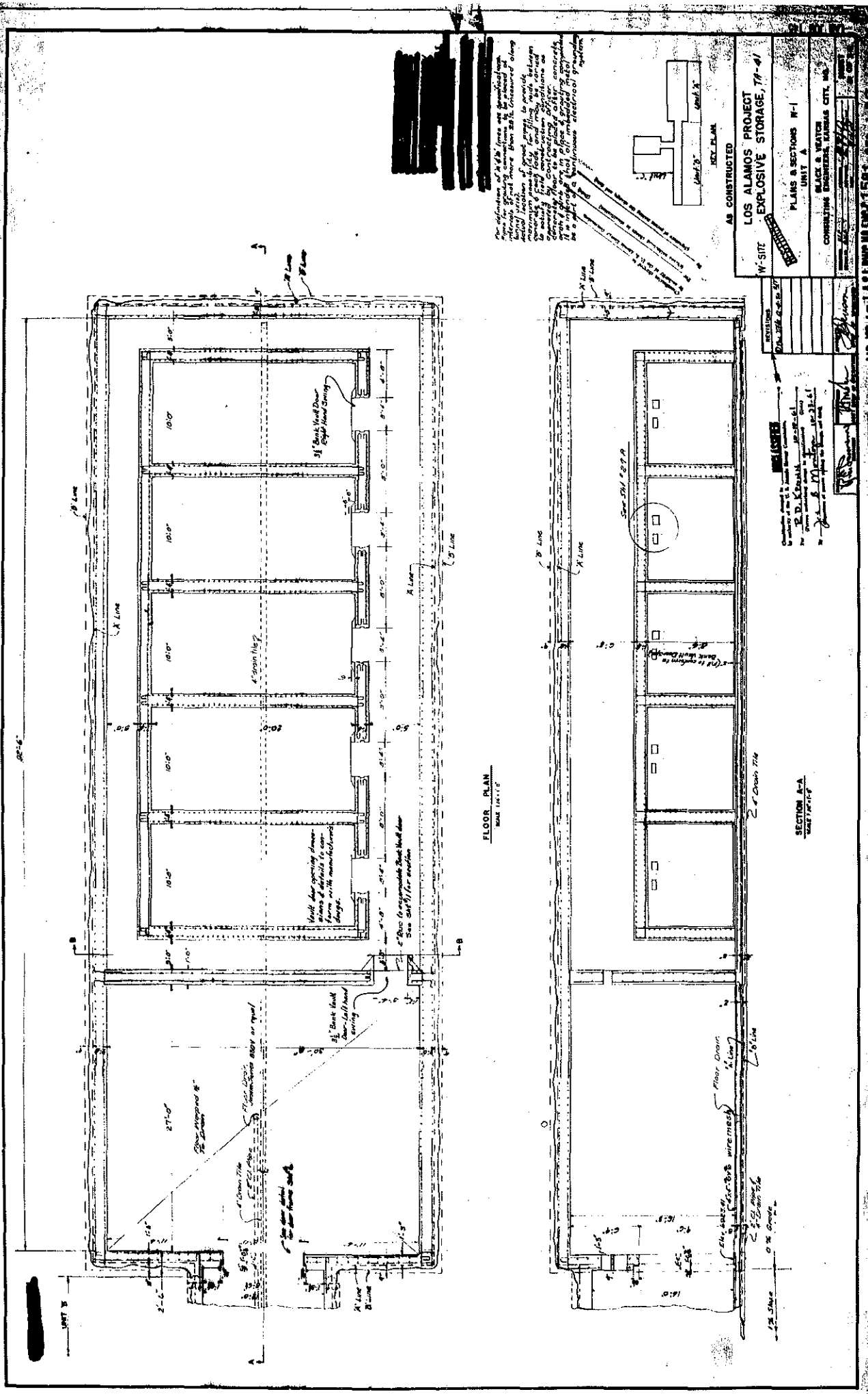

FLOOR PLAN  
SCALE 1/4" = 1'-0"

SECTION A-A  
SCALE 1/4" = 1'-0"

AS CONSTRUCTED  
LOS ALAMOS PROJECT  
EXPLOSIVE STORAGE, TA-41  
PLANS & SECTIONS N-1  
UNIT 2  
BLACK & WHITE  
CONSULTING ENGINEERS, SAN DIEGO, CALIF.

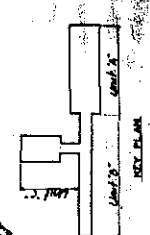

REVISIONS  
DATE  
BY  
CHECKED  
DATE  
BY

US 16 15 LAJW 158A

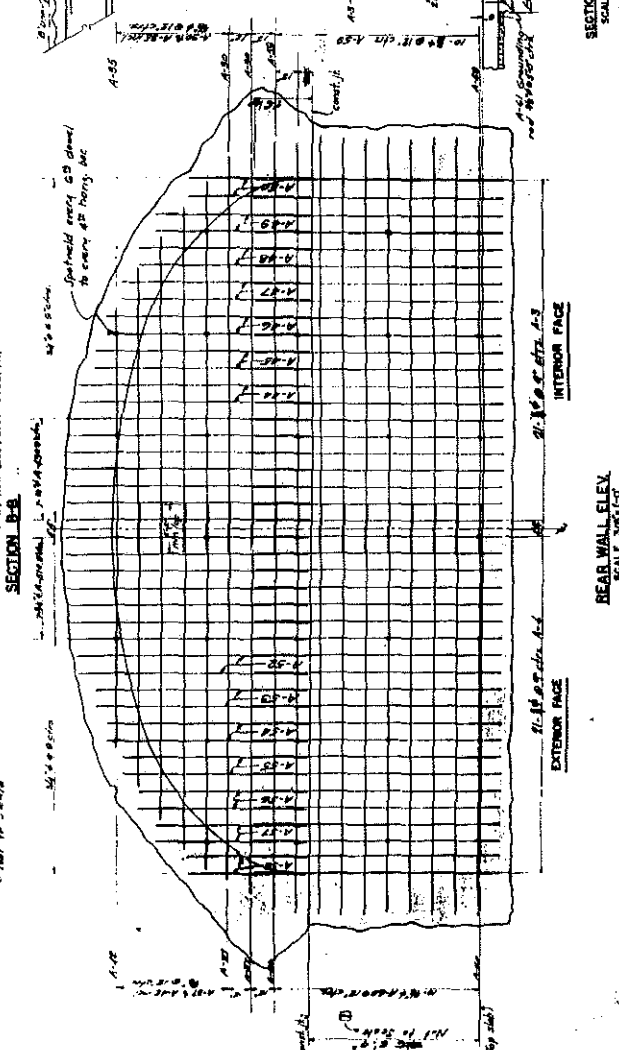
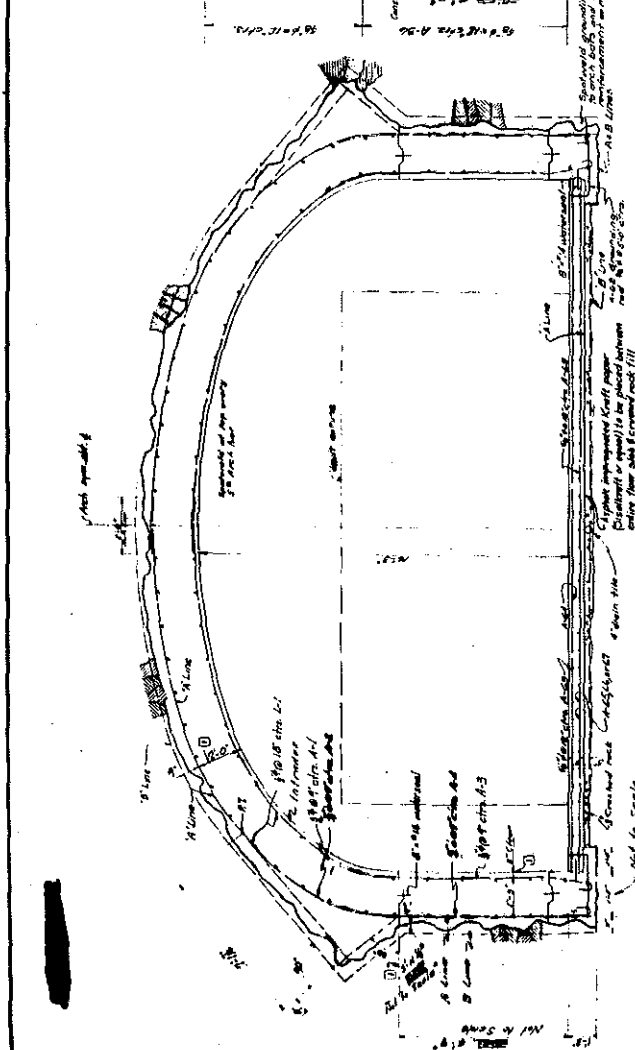
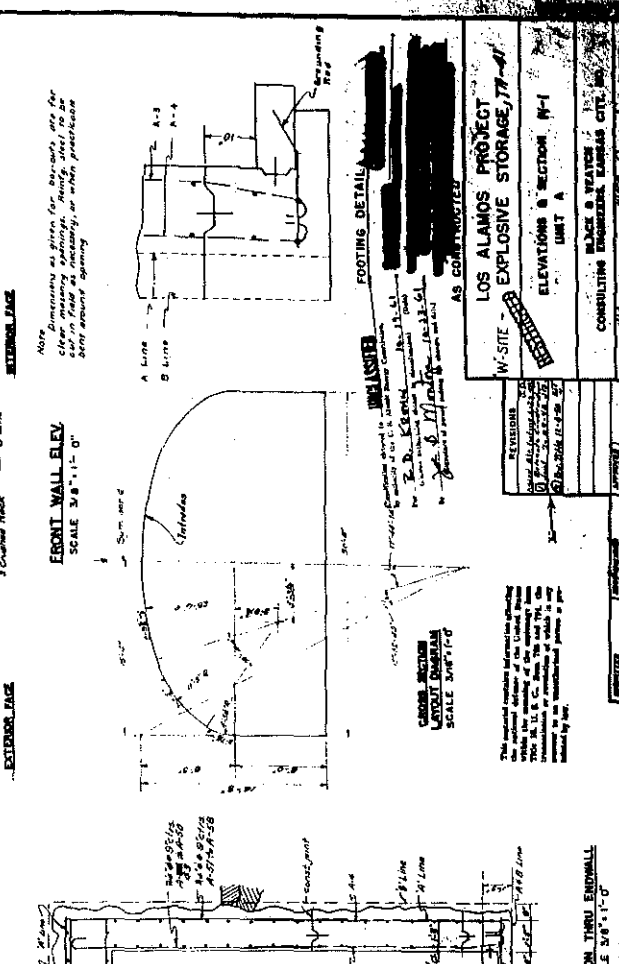
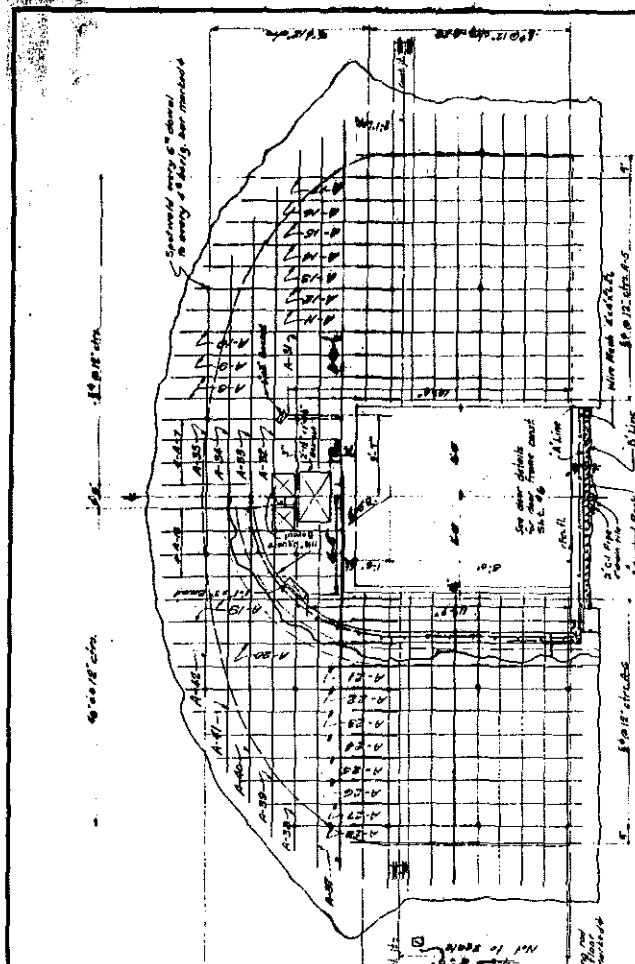

**LOS ALAMOS PROJECT**  
**EXPLOSIVE STORAGE, 77-41**  
 ELEVATIONS & SECTION, 10-1  
 SHEET A

BLACK & VEATCH  
 CONSULTING ENGINEERS, LAS VEGAS, NV  
 AS CONTRACTOR

REVISIONS  
 1. [REDACTED]  
 2. [REDACTED]  
 3. [REDACTED]

The structural conditions indicated on these drawings are based on the information furnished by the client. The structural engineer is not responsible for the accuracy of the information furnished by the client.

CARBON SECTION  
 LAYOUT DIAGRAM  
 SCALE 3/8"=1'-0"

FOOTING DETAIL  
 [REDACTED]

SECTION THRU EXTERIOR WALL  
 SCALE 3/8"=1'-0"

REAR WALL ELEV.  
 SCALE 3/8"=1'-0"

INTERIOR FACE  
 SCALE 3/8"=1'-0"

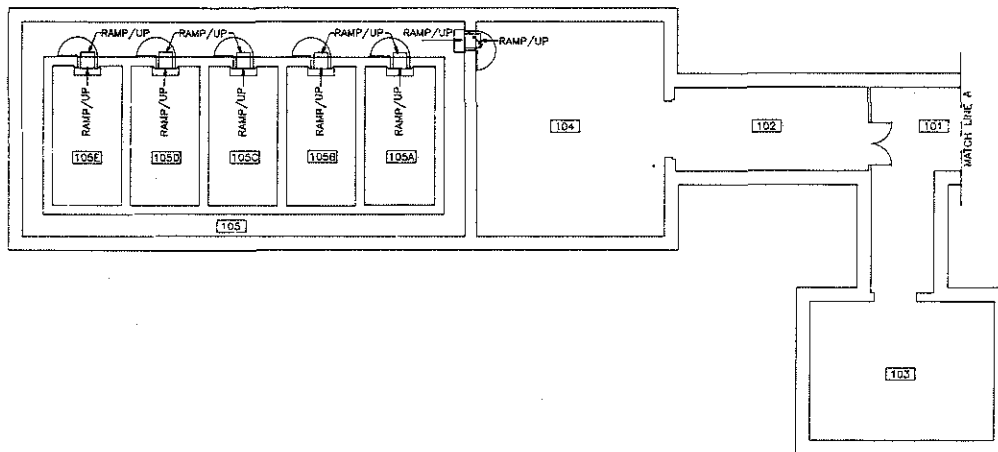
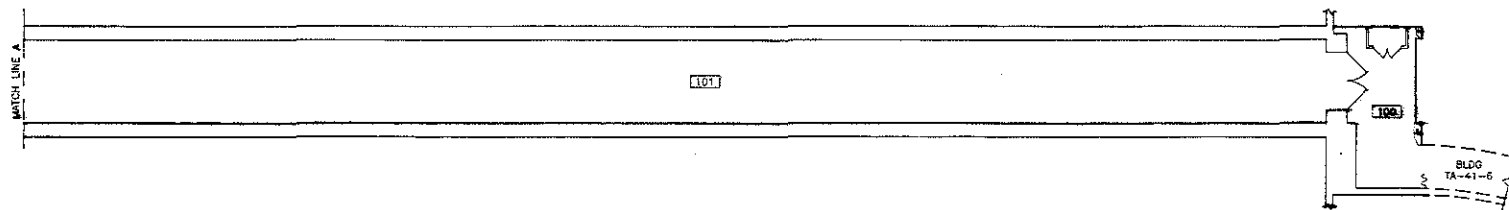

FIRST FLOOR PLAN

SCALE: 1/8" = 1'-0"



NO.	DATE	CLASS. REV.	REVISIONS	OWN	VER	CHK	REL	STAMP	REC	APP
<b>JOHNSON CONTROLS</b> WORLD SERVICES INC.										
<b>AS-BUILT RECORD FLOOR PLAN UNDERGROUND VAULT</b>										
FIRST FLOOR PLAN										
BLDG. 1										
SUBMITTED BY: <i>Jerry Forte</i>										
CHECKED BY: <i>H. Salazar</i>										
RELEASED BY: <i>H. Salazar</i>										
DATE: 03-31-93										
Los Alamos National Laboratory Los Alamos, New Mexico 87545										
CLASSIFICATION: <i>UNCL</i>										
REVIEWER: <i>H. Salazar</i>										
DATE: <i>03-07-93</i>										
PRODUCT ID: <b>7556</b>										
DRAWING NO.: <b>AB111</b>										
SHEET: <b>1</b> OF <b>1</b>										

FIELD VERIFIED 03-05-93

JCI #91-011

LANL TA- Building # 41-0002

Camera 984242

Frame #s DCP\_1086 through DCP\_1092

Surveyor(s) J.Ronquillo/K.Towery

Date 03/05/2002

Los Alamos National Laboratory CRMT  
Historic Building Survey Form

Building Name Guard Station #318 UTM's easting 382951 northing 3970866 zone 13

Legal Description: Map Guaje Mountain Quad 1984 tns 19N range 6E sec 15

Current Use/ Function Guard Station that is currently not in use Original Use/ Function Guard Station

Date (estimated) 1950 Date (actual) 1949 Property Type Security

Type of Construction

Pre-Fabricated Metal  Steel Frame  Wood Frame  CMU  Reinforced Concrete

Other Type of Construction Un-reinforced masonry bearing walls; cast in place concrete walls with CMU addition; upper structure is steel plate will bullet proof windows. # of Stories 1

Foundation Reinforced concrete.

Exterior CMU-Exterior  Reinforced Concrete-Exterior  Steel (galvanized)  Steel (corrugated)   
Wood Siding  Asbestos Shingles-Exterior  In-Fill Panels  Other-Exterior

Exterior Treatment (painted, stuccoed, etc)

Exterior Features (docks, speakers, lights, signs, etc)

Addition CMU-Addition  Reinforced Concrete-Addition  Steel (galvanized)- Addition  Wood   
Steel (corrugated)-Addition  Asbestos Shingles-Addition  Other- Addition

Exterior Treatment-Addition

Exterior Features-Addition

Roof Form Slanted/Shed  Gable  Other Roof Type Pitched with corrugated metal.

Degree of Pitch/ Slope Moderate

Roof Materials Corrugated Metal  Rolled Asphalt  Asbestos Shingles  4-Ply Built Up   
Other Roof Materials

Window Type Casement  Single Hung Sash  Double Hung Sash  Fixed Window   
Other Window Type Impact resistant.

# of Each Window Type/ Comments

Glass Type Clear  Wire Glass  Opaque  Painted Glass  Glass Block

Light Pattern

**Door Type** Personnel Door Types Exterior Fire Door  Single  Double  Roll-up  Sliding   
 Hollow Metal  Solid Wood  1/2 Glazed  Paneled   
 Louvered  Painted

Interior Fire Door  Single  Double  Roll-up  Sliding   
 Hollow Metal  Solid Wood  1/2 Glazed  Paneled   
 Louvered  Painted

Equipment Door Types Exterior Fire Door  Single  Double  Roll-up  Sliding   
 Hollow Metal  Solid Wood  1/2 Glazed  Paneled   
 Louvered  Painted

Interior Fire Door  Single  Double  Roll-up  Sliding   
 Hollow Metal  Solid Metal  1/2 Glazed  Paneled   
 Louvered  Painted

# of Each Door Type/Comments:

**Interior Wall** Gypsum Board  Reinforced Concrete- Interior   
 CMU- Interior  Plywood  Other- Interior   
 In-Wall Electrical Wiring  On-Wall Electrical Wiring

**Ceiling** Drop Ceiling

Interior Comments (Equipment, etc)

**Degree of Remodeling**

**Condition** Excellent  Good  Fair  Deteriorating  Contaminated  Burned

**Associated Building**

If yes, list building names and #s:

**Integrity**

**Significance**

**Eligible Under Criterion** A  B  C  D  Not Eligible

**DOE Themes**

Nuclear Weapon Components and Assembly  Nuclear Weapon Design and Testing  Nuclear Propulsion   
 Peaceful Uses: Plowshare, Nuclear Medicine, Nuclear Energy, Nuclear Science  Energy and Environment: Research Design Projects

**LANL Themes**

Weapons Research and Design, Testing, and Stockpile Support  Super Computing   
 Reactor Technology  Biomedical/Health Physics  Strategic and Supporting Research   
 Environment/Waste Management  Administration and Social History  Architectural History

**Recommendations/ Additional Comments**

**Architectural Features (elevations)**

Steel stair running along one side of building.

**Total sq ft** 781 gross

**Architect/ Builder**

Contractor: Brown and Root

**Alterations**

A CMU equipment room addition was added to the east side of the building in 1985.

**List of Drawings (Cntrl + Enter for para break)**

ENG-C 1593  
Sheet 17 of 36  
Explosive Storage  
TA-41, W-Site  
Sentry House W-2  
Architectural Elevations & Details  
August 1948

ENG-C 43712  
Sheet 2 of 9  
Weapons Safeguards  
TA-41, Bldg W-2  
Civil: Guard Station Floor Plan, Elevations, Section,  
Door & Finish Schedules  
September 28, 1979

ENG-C 43713  
Sheet 3 of 9  
Weapons Safeguards  
TA-41, Bldg W-2  
Civil: Floor Plan, Section & Removal Elevation  
September 28, 1979

ENG-R 3138  
TA-41, Bldg W-2  
Guard House  
First & Second Floor Plans  
September 27, 1983

ENG-C 44520  
Sheet 8 of 31  
TA-41, Bldg W-2, W-54  
Safeguards & Security Upgrades - Phase I  
Power and Lighting  
Arch: Floor Plan, Sections, & Details  
May 20, 1985

ENG-C 44520  
Sheet 9 of 31  
TA-41, Bldg W-2, W-54  
Safeguards & Security Upgrades - Phase I  
Power and Lighting  
Arch: Elevations, W-2 & W-54  
May 20, 1985

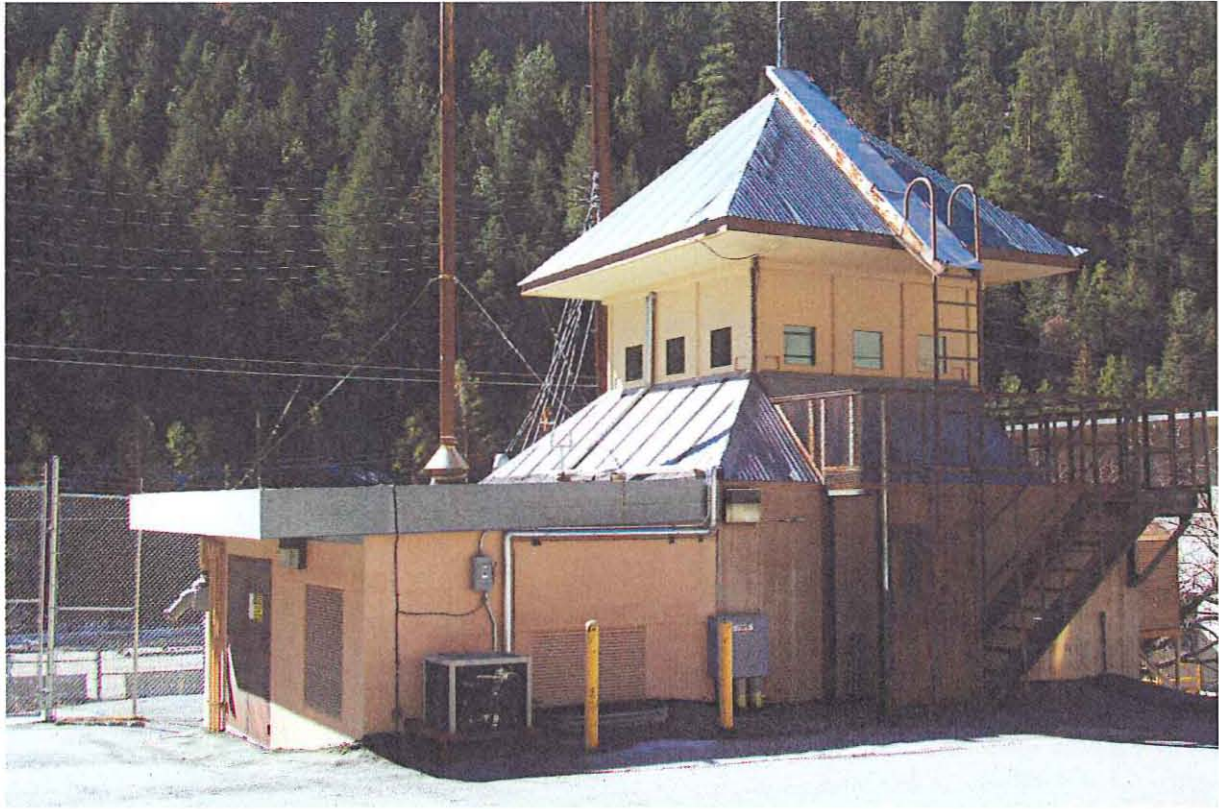

TA-41-2 Guard Station, East and North Elevations

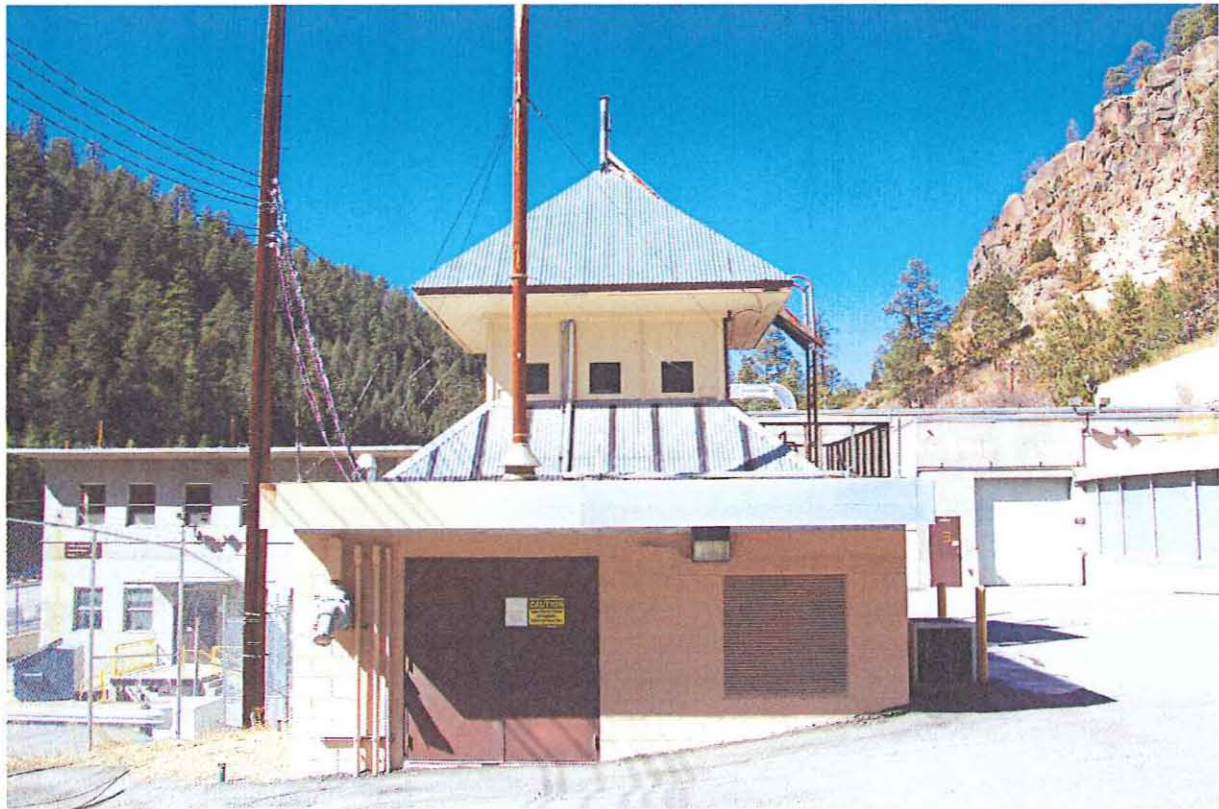

TA-41-2 Guard Station, East Elevation



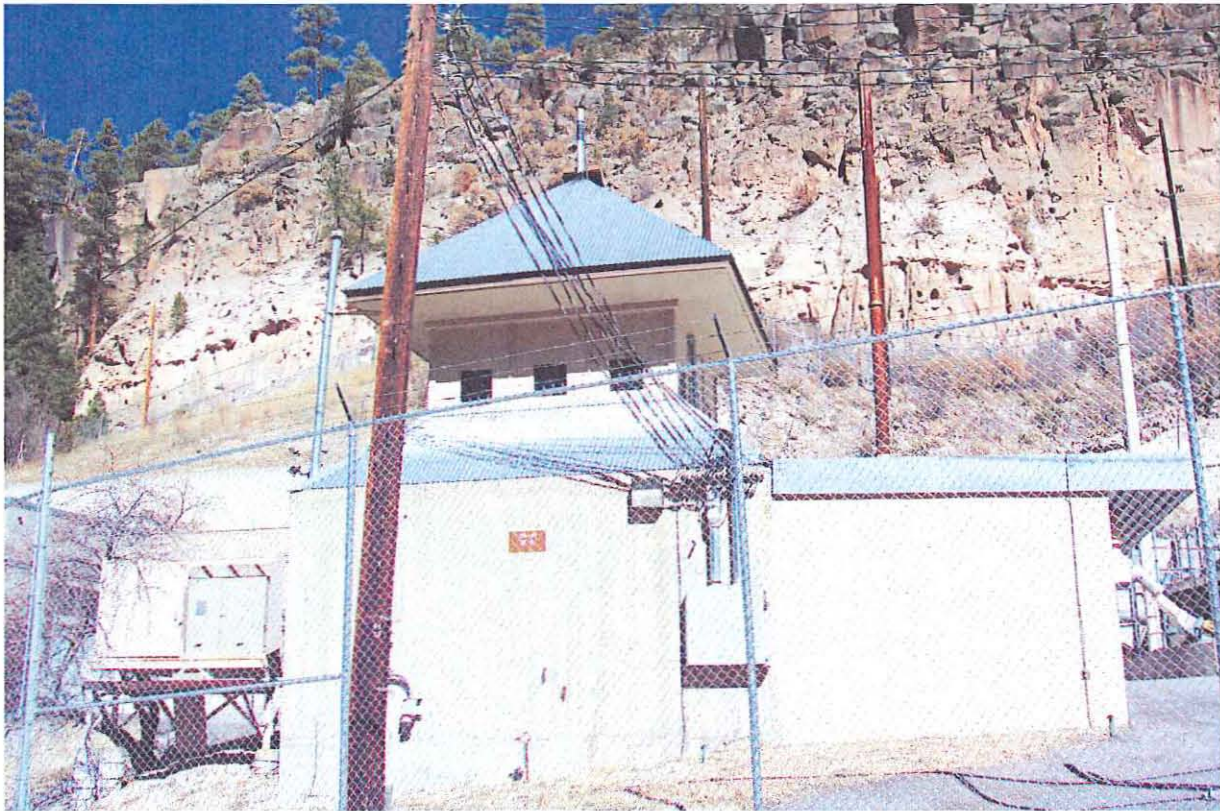

TA-41-2 Guard Station, South Elevation

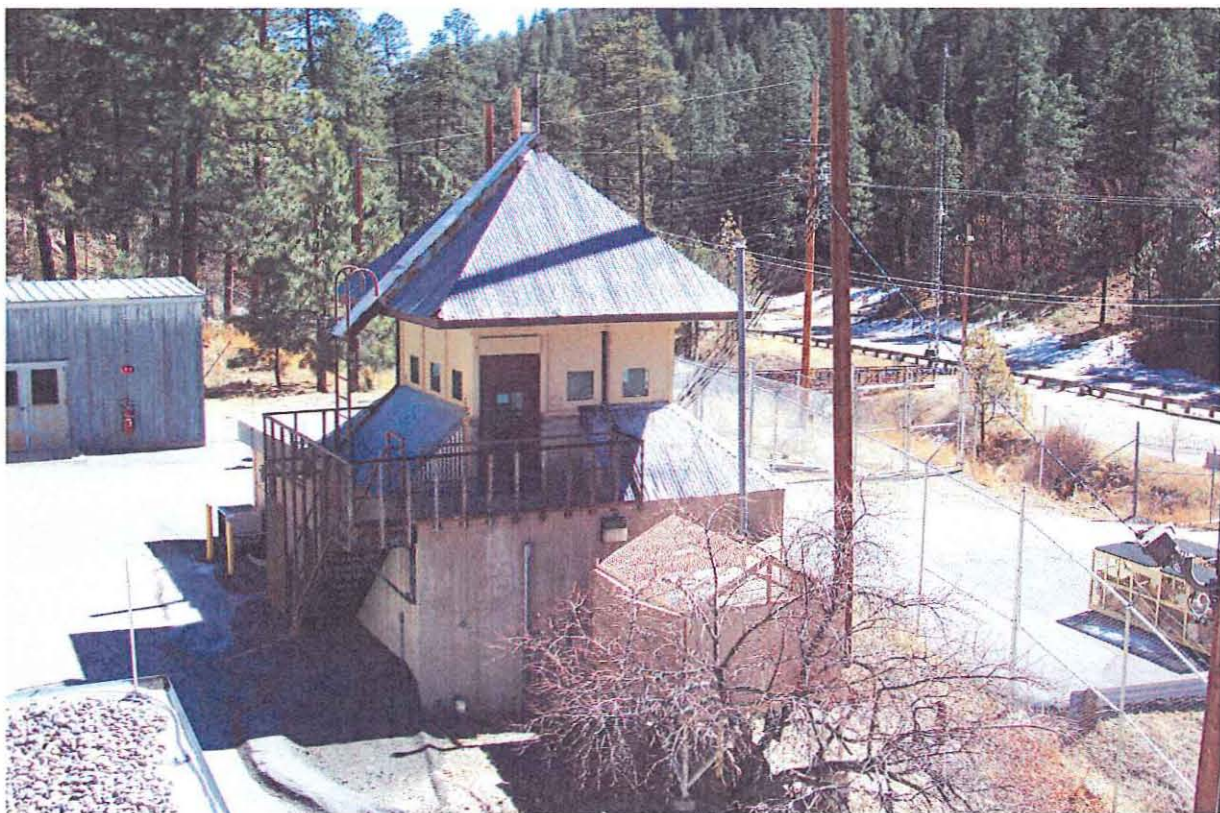

TA-41-2 Guard Station, North and West Elevations

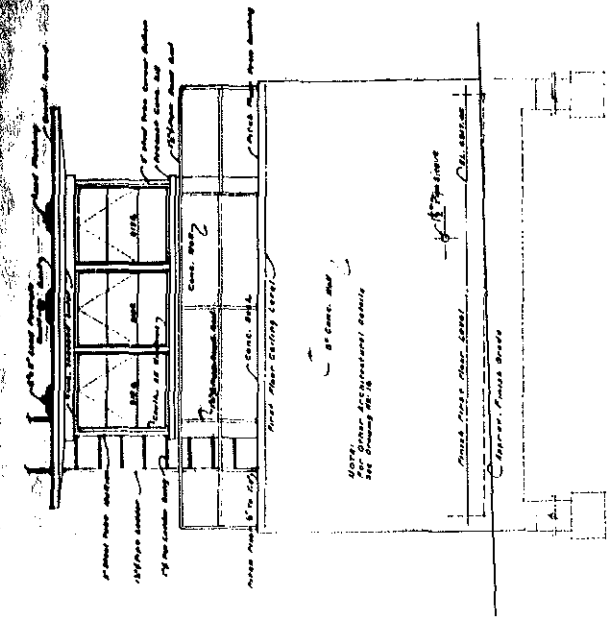

**SOUTH OR SIDE ELEVATION**  
SCALE 1/8" = 1'-0"

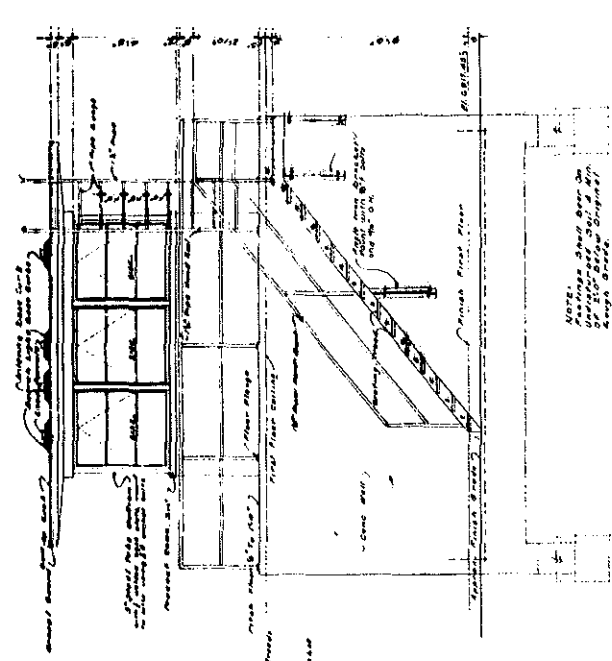

**NORTH OR SIDE ELEVATION**  
SCALE 1/8" = 1'-0"

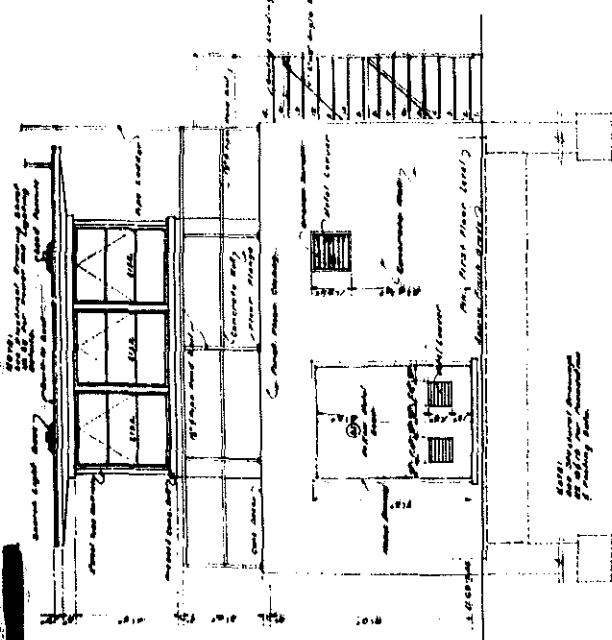

**EAST OR FRONT ELEVATION**  
SCALE 1/8" = 1'-0"

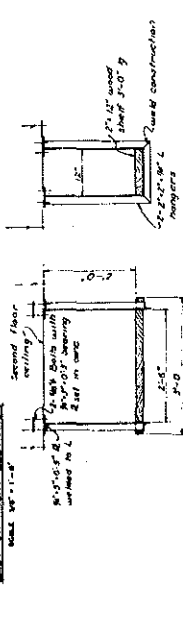

**DOOR**

**SHELF**

NO.	DESCRIPTION	QUANTITY	UNIT	PRICE	TOTAL
1	DOOR HANDLE	1	EA	1.50	1.50
2	DOOR LOCK	1	EA	2.50	2.50
3	DOOR FRAME	1	EA	10.00	10.00
4	DOOR GLASS	1	EA	5.00	5.00
5	DOOR STOP	1	EA	1.00	1.00
6	DOOR HINGE	2	EA	1.00	2.00
7	DOOR LATCH	1	EA	1.00	1.00
8	DOOR PLATE	1	EA	1.00	1.00
9	DOOR SILL	1	EA	1.00	1.00
10	DOOR CASE	1	EA	1.00	1.00
11	DOOR STOP	1	EA	1.00	1.00
12	DOOR HINGE	2	EA	1.00	2.00
13	DOOR LATCH	1	EA	1.00	1.00
14	DOOR PLATE	1	EA	1.00	1.00
15	DOOR SILL	1	EA	1.00	1.00
16	DOOR CASE	1	EA	1.00	1.00
17	DOOR STOP	1	EA	1.00	1.00
18	DOOR HINGE	2	EA	1.00	2.00
19	DOOR LATCH	1	EA	1.00	1.00
20	DOOR PLATE	1	EA	1.00	1.00
21	DOOR SILL	1	EA	1.00	1.00
22	DOOR CASE	1	EA	1.00	1.00
23	DOOR STOP	1	EA	1.00	1.00
24	DOOR HINGE	2	EA	1.00	2.00
25	DOOR LATCH	1	EA	1.00	1.00
26	DOOR PLATE	1	EA	1.00	1.00
27	DOOR SILL	1	EA	1.00	1.00
28	DOOR CASE	1	EA	1.00	1.00
29	DOOR STOP	1	EA	1.00	1.00
30	DOOR HINGE	2	EA	1.00	2.00

Other hardware - same as shown on basic requirements set forth in the Building General Specification, 1941-1942 and Amendment, Hardware Building, Hardware Schedule sheet to reference the item numbers and quantities indicated on the drawings. Purpose of reference the item numbers and quantities of the hardware shown on the drawings is to indicate the items and quantities of the hardware shown on the drawings. The items and quantities of the hardware shown on the drawings are subject to change without notice and will be accepted by the Contracting Officer in the items designated sheet will be accepted.

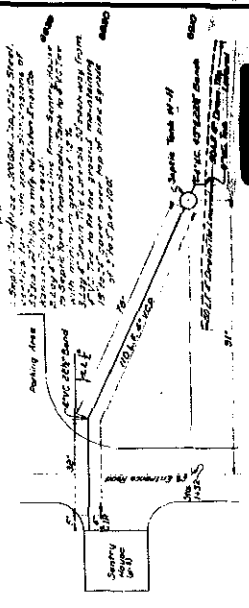

**SITE PLAN**  
SCALE 1/4" = 1'-0"

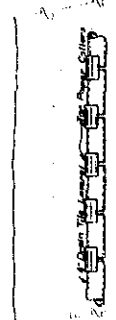

**LONGITUDINAL SECTION**  
SCALE 1/8" = 1'-0"

**UNCLASSIFIED**

PROPERTY OF THE U.S. GOVERNMENT  
GPO: 1964 O - 284-121

**SENTRY HOUSE SEWERAGE FACILITIES**

FOR THE  
U.S. ARMY  
CORPUS OF ENGINEERS  
WASHINGTON, D.C.

**LOS ALAMOS PROJECT**  
SITE - EXPLOSIVE STORAGE, T-9-41

ARCHITECTURAL ELEVATIONS & DETAILS  
SENTRY HOUSE N-2

BLACK & VEATCH  
CONSULTING ENGINEERS, LAS VEGAS, NV.

LAB 708 105 LAS VEGAS, NV 89103 87A-107

E.N.I.E.M. SCHEDULE				
FLOOR	DOORS	FRAMES	WALLS	ROOF
INTERIOR	F-1	M-1	M-1	N/A
EXTERIOR	N/A	M-2	M-2	N/A

FLOOR  
 F-1 = EKEELON, VINYL ASBESTOS 12" x 12" FAWN WHITE TILE  
 WALLS, DOORS, FRAMES & TRIM  
 M-1 = PPC, NO. 22518 PARACRENT  
 M-2 = PPC, NO. 87211 FLAME DRANGE  
 M-3 = PPC, NO. 87633 FALCON WING  
 ALSO, MECH. & ELEC. EQUIPMENT  
 SAME AS ABOVE  
 EXTERIOR B.S. WINDOWS  
 S-1 = SOLAR BRUNNE TINT

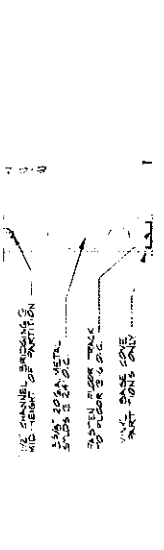

PARTITION SECTION  
 SCALE: 3/8" = 1'-0"

DATE	BY	REVISION	NO.
10/10/77	DR	REVISED	1
DEPARTMENT OF ENERGY WEAPONS SAFEGUARDS CIVIL GUARD STATION FLOOR PLAN, ELEVATIONS, SECTION, DOOR & FINISH SCHEDULES			
BLDG NO.	PROJECT NO.	DATE	SCALE
NA	DR-3887	10-4-77	C2 2 9
DESIGNED BY	CHECKED BY	DATE	SCALE
DR-3887	DR-3887	10-4-77	C2 2 9
LAB. NO.	LAB. NAME	LAB. ADDRESS	LAB. CITY
DR-3887	DR-3887	DR-3887	DR-3887
LAB. NO.	LAB. NAME	LAB. ADDRESS	LAB. CITY
DR-3887	DR-3887	DR-3887	DR-3887
LAB. NO.	LAB. NAME	LAB. ADDRESS	LAB. CITY
DR-3887	DR-3887	DR-3887	DR-3887
LAB. NO.	LAB. NAME	LAB. ADDRESS	LAB. CITY
DR-3887	DR-3887	DR-3887	DR-3887
LAB. NO.	LAB. NAME	LAB. ADDRESS	LAB. CITY
DR-3887	DR-3887	DR-3887	DR-3887
LAB. NO.	LAB. NAME	LAB. ADDRESS	LAB. CITY
DR-3887	DR-3887	DR-3887	DR-3887
LAB. NO.	LAB. NAME	LAB. ADDRESS	LAB. CITY
DR-3887	DR-3887	DR-3887	DR-3887
LAB. NO.	LAB. NAME	LAB. ADDRESS	LAB. CITY
DR-3887	DR-3887	DR-3887	DR-3887

DOOR SCHEDULE						
MARK	DOOR SIZE	GLAZING	HANDWARE	CLOSER	PANIC BAR	DESCRIPTION
A	3' x 7'	2 1/2" x 2 1/2" x 2 1/2" R.R. WINDOW CORE	CEL. LOCK SET TO FIT BEST CORE	YES	YES	BULLET RESISTANT (SEE SPEC 21 SHEET 21)
B	2'-8" x 7' x 1 1/2"	2'-0" x 2'-0" x 2'-0" R.R. WINDOW CORE	LATCH SET	NO	NO	WOOD HOLLOW DOOR

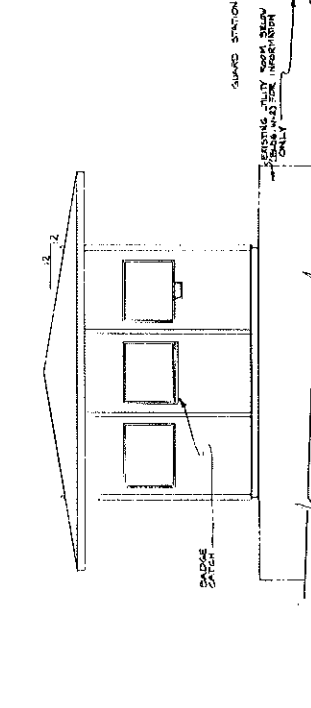
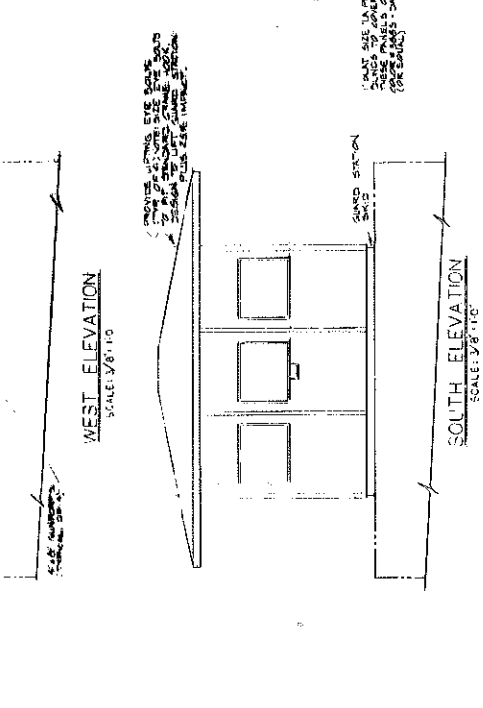
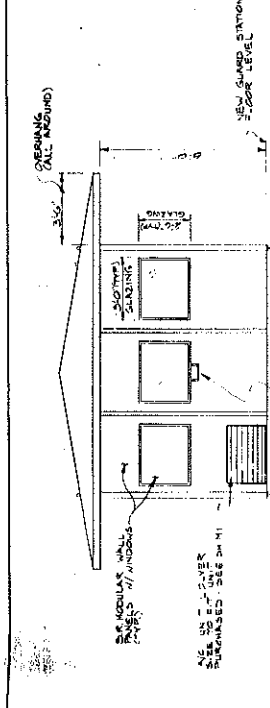
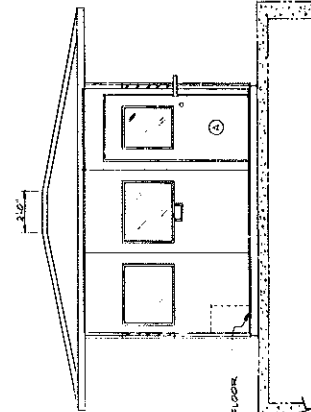
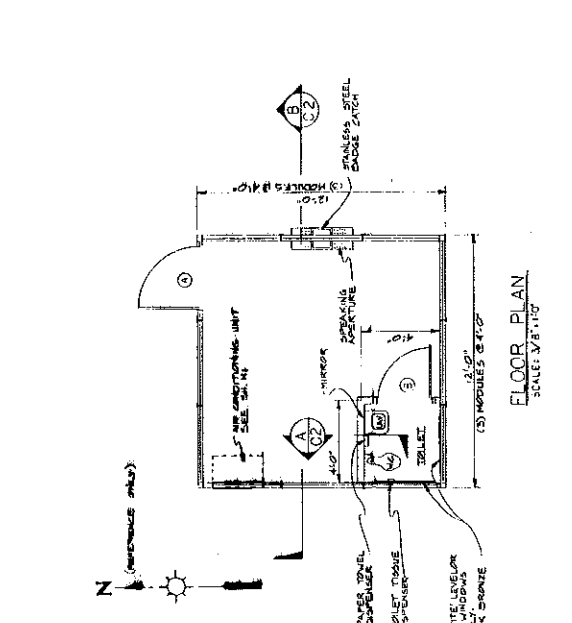



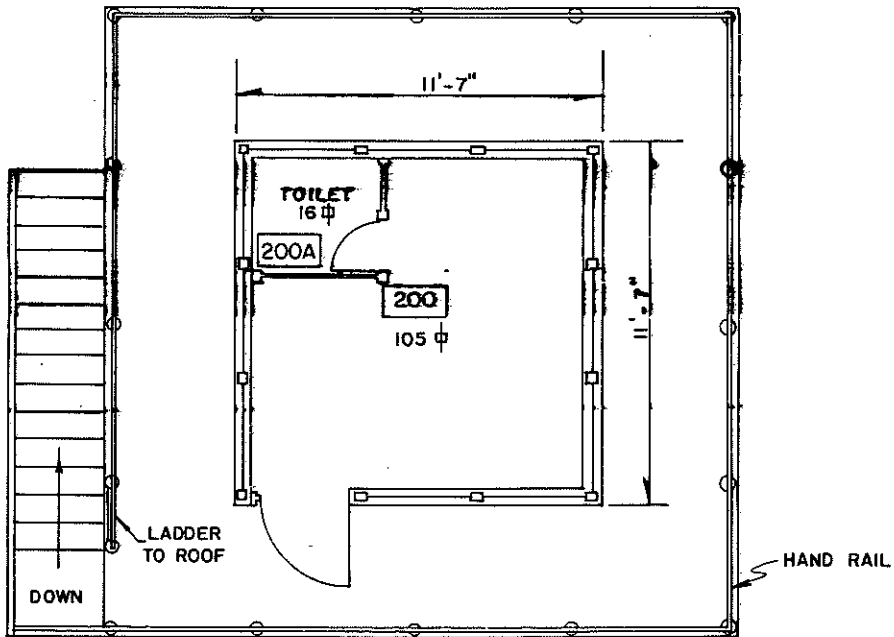

SECOND FLOOR

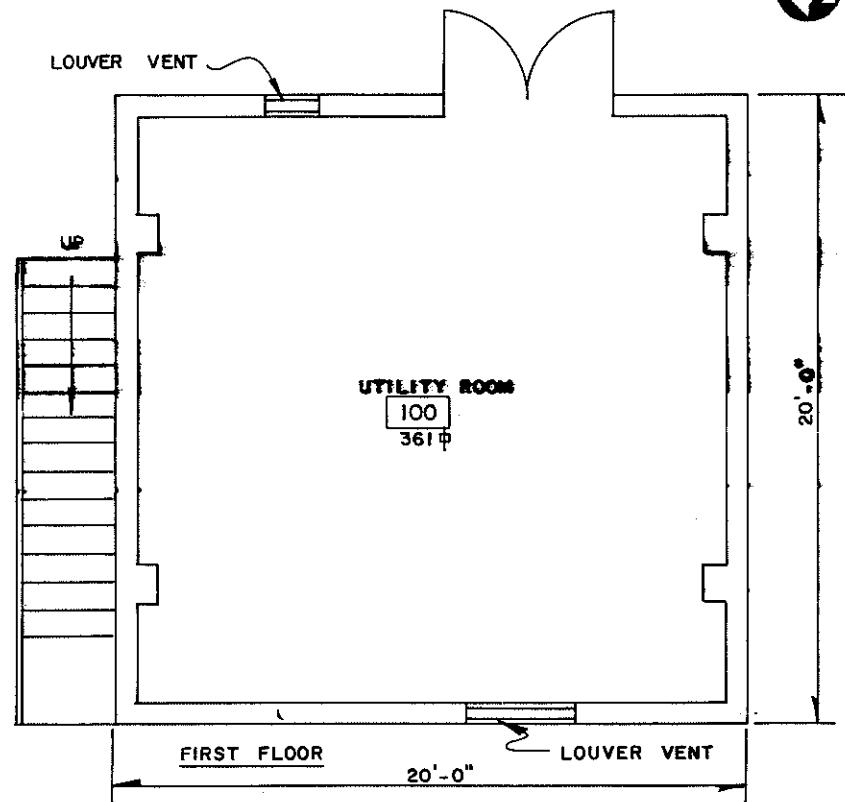

FIRST FLOOR

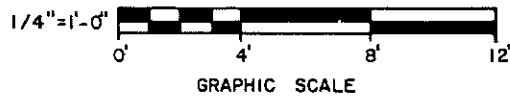

TOTAL SQ. FT. 482

REV.	DATE	REVISION	BY	CRD.	APP.
2	2-2-84	REVISED TO STATUS OF 2-2-84	HBN	ST	DR
1	9-27-83	REDRAWN & REVISED TO STATUS OF 09/27/83	HBN	ST	DR

UNIVERSITY OF CALIFORNIA  
**Los Alamos**  
 Los Alamos National Laboratory  
 Los Alamos, New Mexico 87545

FACILITIES ENGINEERING DIVISION

**GUARD HOUSE**  
**FIRST & SECOND FLOOR PLANS**

BLDG. W-2 TA-41

SEC. CLASSIFICATION  
 CLASS. *U*  
 REVIEWER *[Signature]*  
 DATE *2-6-84*

SUBMITTED <i>[Signature]</i>	RECOMMENDED <i>[Signature]</i>	APPROVED <i>[Signature]</i>
DRAWN H&N	DATE 09/27/83	SHEET NO. 1 OF 1
CHECKED <i>[Signature]</i>	DATE	DRAWING NO. ENG-R3138

REC'D \_\_\_\_\_ LOGGED \_\_\_\_\_ TO VAULT *[Signature]*

**KEYED NOTES:**  
 ① REMOVE EXIST. DOUBLE DOOR  
 IF NEW DOUBLE DOOR SCHEDULE  
 TO REMAIN, SEE DOOR SCHEDULE

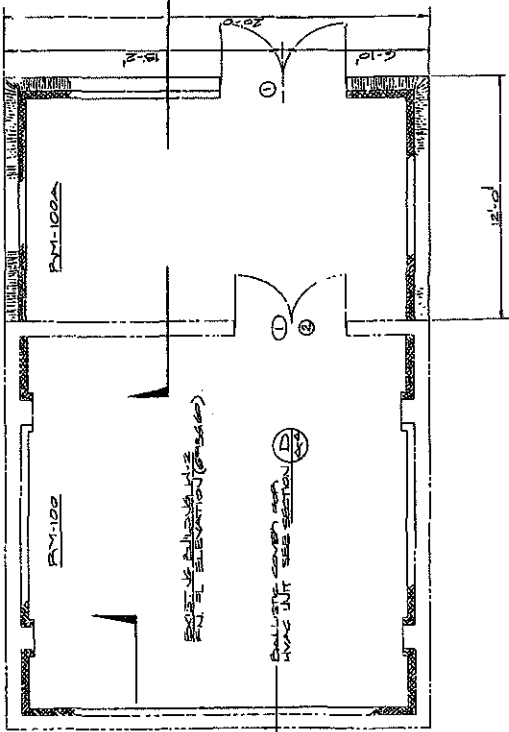

**FLOOR PLAN**  
 SCALE: 1/8" = 1'-0"

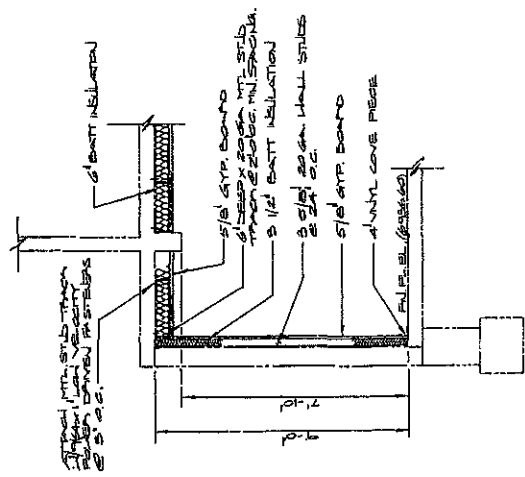

**SECTION 1-1**  
 SCALE: 1/2" = 1'-0"

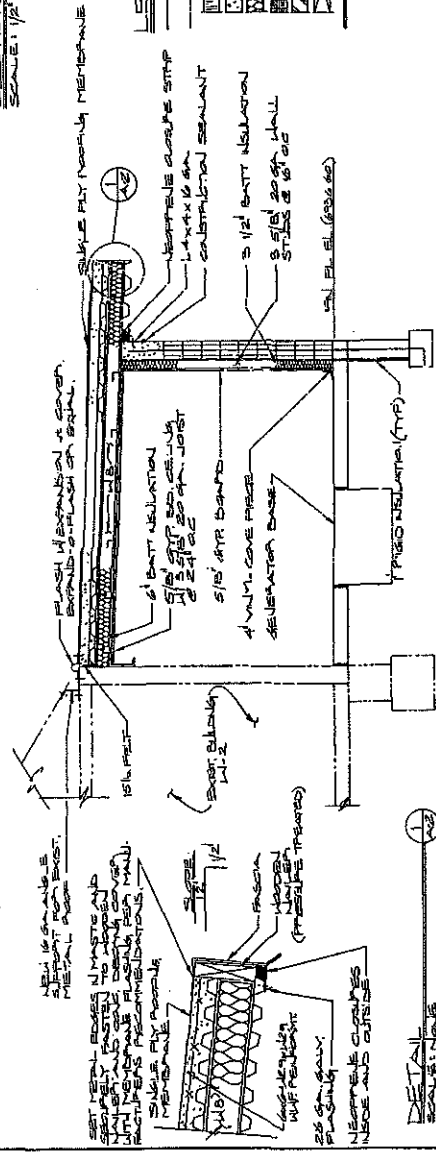

**SECTION 2-2**  
 SCALE: 1/2" = 1'-0"

**LEGEND:**

- NEW CONSTRUCTION
- EXIST. CONSTRUCTION
- CONCRETE BLOCK (CMU)
- CONCRETE
- BATT INSULATION
- INSULATION
- METAL
- WOOD FRAMING
- ROOF MEMBRANE

FACILITIES ENGINEERING DIVISION			
DATE	BY	CHKD	APP'D
SAFETY - PHASE I			
POWER AND LIGHTING			
ARCHITECTURAL DETAILS			
PROJECT NO. 1041			
DATE 10-22-85			
DRAWN BY: <i>Steve Schuman</i>			
CHECKED BY: <i>Steve Schuman</i>			
APPROVED BY: <i>Steve Schuman</i>			
PROJECT NO. 1041			
DATE 10-22-85			
DRAWING NO. ENG-C44520			
SHEET 3 OF 5			
CLASSIFICATION: <i>SECRET</i>			
PROJECT NAME: <i>Los Alamos National Laboratory</i>			
PROJECT NO. <i>8065-4</i>			
DRAWING NO. <i>ENG-C44520</i>			
REV.			

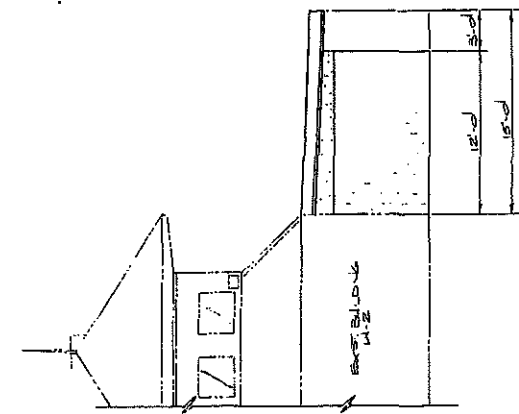

**SOUTH ELEVATION**  
SCALE: 1/4" = 1'-0"

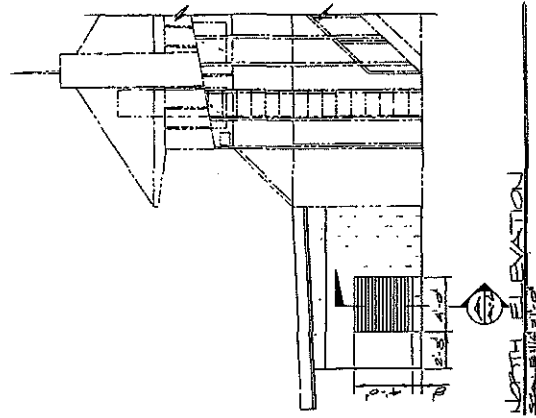

**NORTH ELEVATION**  
SCALE: 1/4" = 1'-0"

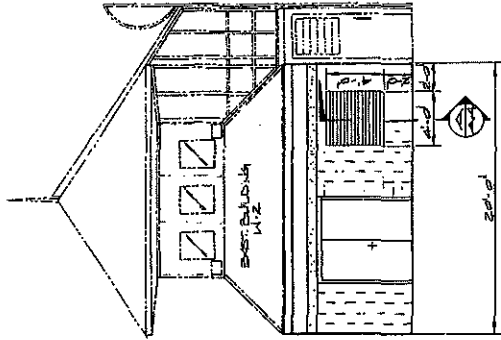

**EAST ELEVATION**  
SCALE: 1/4" = 1'-0"

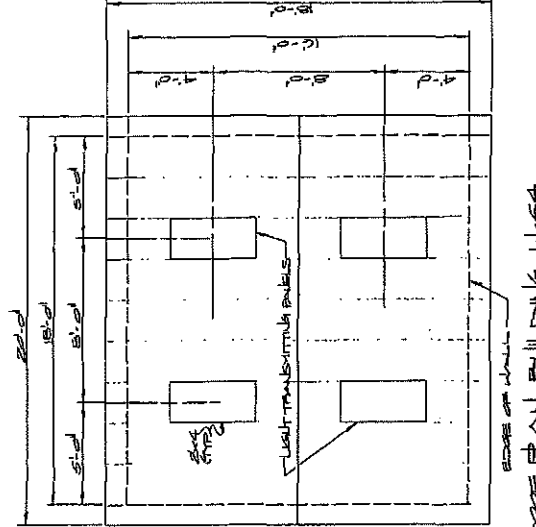

**WEST ELEVATION**  
SCALE: 1/4" = 1'-0"

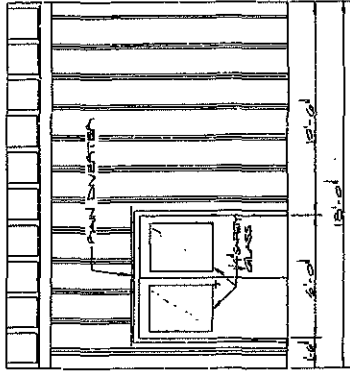

**WEST ELEVATION (FRONT)**  
SCALE: 1/4" = 1'-0"

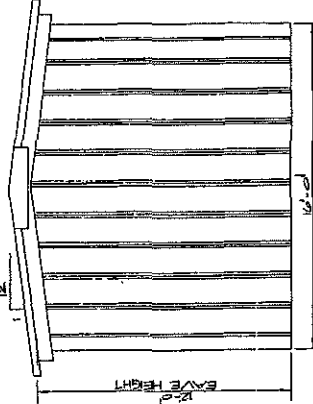

**NORTH & SOUTH ELEVATION (SIDES)**  
SCALE: 1/4" = 1'-0"

PRE-ENGINEERED METAL BUILDING W-54  
SEE FIG. 2-SP-1167 FOR METAL CLSD. SPECIFICATIONS

NO.	DATE	BY	REV.	DESCRIPTION
1	11/18/82	JM	1	ISSUED FOR PERMITS
2	12/18/82	JM	2	REVISED PER COMMENTS
3	1/15/83	JM	3	REVISED PER COMMENTS
4	2/17/83	JM	4	REVISED PER COMMENTS

FACILITIES ENGINEERING DIVISION		
PROJECT	AREA	NO.
PHASE	NO.	NO.
CLIENT	NO.	NO.
NO.	NO.	NO.

Los Alamos			
DESIGNED BY	CHECKED BY	DATE	REV.
<i>[Signature]</i>	<i>[Signature]</i>	11/18/82	1
PROJECT NO.	DATE	PROJECT NO.	DATE
2065-41	11/18/82	2065-41	11/18/82
ENGINEER	DATE	ENGINEER	DATE
<i>[Signature]</i>	11/18/82	<i>[Signature]</i>	11/18/82

Los Alamos National Laboratory  
2065-41 ENG-044-520

LANL TA- Building # 41-0003

Camera 984242

Frame #s DCP\_1098 and DCP\_1116

Surveyor(s) K.Towery/J.Ronquillo

Date 03/05/2002

Los Alamos National Laboratory CRMT  
Historic Building Survey Form

Building Name Blower House UTM's easting 382936 northing 3970899 zone 13

Legal Description: Map Guaje Mountain Quad 1984 tnspl 19N range 6E sec 15

Current Use/ Function Air is transferred via 16" duct to vault, TA-41-1. Original Use/ Function Air is transferred via 16" duct to vault

Date (estimated) 1950 Date (actual) 1949 Property Type Support

Type of Construction

Pre-Fabricated Metal  Steel Frame  Wood Frame  CMU  Reinforced Concrete

Other Type of Construction Concrete shear walls. # of Stories 1

Foundation Reinforced concrete.

Exterior CMU-Exterior  Reinforced Concrete-Exterior  Steel (galvanized)  Steel (corrugated)

Wood Siding  Asbestos Shingles-Exterior  In-Fill Panels  Other-Exterior

Exterior Treatment (painted, stuccoed, etc) Unpainted exposed concrete.

Exterior Features (docks, speakers, lights, signs, etc) Large metal louvered grill on the south elevation.

Addition CMU-Addition  Reinforced Concrete-Addition  Steel (galvanized)- Addition  Wood

Steel (corrugated)-Addition  Asbestos Shingles-Addition  Other- Addition N/A

Exterior Treatment-Addition

Exterior Features-Addition

Roof Form Slanted/Shed  Gable  Other Roof Type

Degree of Pitch/ Slope Slight

Roof Materials Corrugated Metal  Rolled Asphalt  Asbestos Shingles  4-Ply Built Up

Other Roof Materials

Window Type Casement  Single Hung Sash  Double Hung Sash  Fixed Window

Other Window Type N/A

# of Each Window Type/ Comments N/A

Glass Type Clear  Wire Glass  Opaque  Painted Glass  Glass Block

Light Pattern

Door Type Personnel Door Types Exterior Fire Door  Single  Double  Roll-up  Sliding



		Hollow Metal <input type="checkbox"/>	Solid Wood <input type="checkbox"/>	1/2 Glazed <input type="checkbox"/>	Paneled <input type="checkbox"/>	
		Louvered <input type="checkbox"/>	Painted <input type="checkbox"/>			
	Interior	Fire Door <input type="checkbox"/>	Single <input type="checkbox"/>	Double <input type="checkbox"/>	Roll-up <input type="checkbox"/>	Sliding <input type="checkbox"/>
		Hollow Metal <input type="checkbox"/>	Solid Wood <input type="checkbox"/>	1/2 Glazed <input type="checkbox"/>	Paneled <input type="checkbox"/>	
		Louvered <input type="checkbox"/>	Painted <input type="checkbox"/>			
Equipment Door Types	Exterior	Fire Door <input type="checkbox"/>	Single <input type="checkbox"/>	Double <input type="checkbox"/>	Roll-up <input type="checkbox"/>	Sliding <input type="checkbox"/>
		Hollow Metal <input type="checkbox"/>	Solid Wood <input type="checkbox"/>	1/2 Glazed <input type="checkbox"/>	Paneled <input type="checkbox"/>	
		Louvered <input type="checkbox"/>	Painted <input type="checkbox"/>			
	Interior	Fire Door <input type="checkbox"/>	Single <input type="checkbox"/>	Double <input type="checkbox"/>	Roll-up <input type="checkbox"/>	Sliding <input type="checkbox"/>
		Hollow Metal <input type="checkbox"/>	Solid Metal <input type="checkbox"/>	1/2 Glazed <input type="checkbox"/>	Paneled <input type="checkbox"/>	
		Louvered <input type="checkbox"/>	Painted <input type="checkbox"/>			

# of Each Door Type/Comments:

**Interior Wall** Gypsum Board  Reinforced Concrete- Interior

CMU- Interior  Plywood  Other- Interior

In-Wall Electrical Wiring  On-Wall Electrical Wiring

**Ceiling** Drop Ceiling

Interior Comments (Equipment, etc)

**Degree of Remodeling**

**Condition** Excellent  Good  Fair  Deteriorating  Contaminated  Burned

**Associated Building**

If yes, list building names and #:

**Integrity**

**Significance**

**Eligible Under Criterion** A  B  C  D  Not Eligible

**DOE Themes**

Nuclear Weapon Components and Assembly  Nuclear Weapon Design and Testing  Nuclear Propulsion

Peaceful Uses: Plowshare, Nuclear Medicine, Nuclear Energy, Nuclear Science  Energy and Environment: Research Design Projects

**LANL Themes**

Weapons Research and Design, Testing, and Stockpile Support  Super Computing

Reactor Technology  Biomedical/Health Physics  Strategic and Supporting Research

Environment/Waste Management  Administration and Social History  Architectural History

**Recommendations/ Additional Comments**

**Architectural Features (elevations)**

Exposed concrete walls with a large metal louver on the south elevation.

**Total sq ft** 24 Gross

**Architect/ Builder**

Contractor: Brown & Root

**Alterations**

**List of Drawings (Ctrl + Enter for para break)**

ENG-R 3377  
TA-41, Building W-3  
Blower House  
Floor Plan  
January 22, 1963



TA-41-3 Blower House Air Intake, South Elevation

**Door Type**

Personnel Door Types	Exterior	Fire Door	<input type="checkbox"/>	Single	<input checked="" type="checkbox"/>	Double	<input checked="" type="checkbox"/>	Roll-up	<input checked="" type="checkbox"/>	Sliding	<input type="checkbox"/>	
		Hollow Metal	<input checked="" type="checkbox"/>	Solid Wood	<input type="checkbox"/>	1/2 Glazed	<input type="checkbox"/>	Paneled	<input type="checkbox"/>	Louvered	<input type="checkbox"/>	
		Painted	<input type="checkbox"/>									
	Interior	Fire Door	<input type="checkbox"/>	Single	<input checked="" type="checkbox"/>	Double	<input checked="" type="checkbox"/>	Roll-up	<input type="checkbox"/>	Sliding	<input type="checkbox"/>	
	Hollow Metal	<input checked="" type="checkbox"/>	Solid Wood	<input type="checkbox"/>	1/2 Glazed	<input type="checkbox"/>	Paneled	<input type="checkbox"/>	Louvered	<input type="checkbox"/>		
	Painted	<input type="checkbox"/>										
Equipment Door Types	Exterior	Fire Door	<input type="checkbox"/>	Single	<input checked="" type="checkbox"/>	Double	<input checked="" type="checkbox"/>	Roll-up	<input checked="" type="checkbox"/>	Sliding	<input type="checkbox"/>	
		Hollow Metal	<input type="checkbox"/>	Solid Wood	<input type="checkbox"/>	1/2 Glazed	<input type="checkbox"/>	Paneled	<input type="checkbox"/>	Louvered	<input type="checkbox"/>	
		Painted	<input type="checkbox"/>									
	Interior	Fire Door	<input type="checkbox"/>	Single	<input checked="" type="checkbox"/>	Double	<input type="checkbox"/>	Roll-up	<input type="checkbox"/>	Sliding	<input type="checkbox"/>	
	Hollow Metal	<input type="checkbox"/>	Solid Metal	<input type="checkbox"/>	1/2 Glazed	<input type="checkbox"/>	Paneled	<input type="checkbox"/>	Louvered	<input type="checkbox"/>		
	Painted	<input type="checkbox"/>										

# of Each Door Type/Comments:

**Interior Wall**

Gypsum Board  Reinforced Concrete- Interior

CMU- Interior  Plywood  Other- Interior

In-Wall Electrical Wiring  On-Wall Electrical Wiring

**Ceiling** Drop Ceiling

Interior Comments (Equipment, etc)

**Degree of Remodeling**

**Condition** Excellent  Good  Fair  Deteriorating  Contaminated  Burned

**Associated Building**

If yes, list building names and #s:

**Integrity**

**Significance**

**Eligible Under Criterion** A  B  C  D  Not Eligible

**DOE Themes**

Nuclear Weapon Components and Assembly  Nuclear Weapon Design and Testing  Nuclear Propulsion

Peaceful Uses: Plowshare, Nuclear Medicine, Nuclear Energy, Nuclear Science  Energy and Environment: Research Design Projects

**LANL Themes**

Weapons Research and Design, Testing, and Stockpile Support  Super Computing

Reactor Technology  Biomedical/Health Physics  Strategic and Supporting Research

Environment/Waste Management  Administration and Social History  Architectural History

**Recommendations/ Additional Comments**

**Architectural Features (elevations)**

This building exterior architectural style is unpainted concrete with clean elevations with symmetrically placed operable windows around each of its elevations. The building is functional with no features added other than what needs to be there. There is some glass block on the east elevation. The glass block serves as a functional element for bringing in natural light, but also provides some visual security. This material was used throughout the building in similar type applications.

**Total sq ft** 40,565 Gross

**Architect/ Builder**

A/E Firm: Skidmore, Owings, and Merrill Contractor:  
R.E. McKee

**Alterations**

An addition referred to as the "Annex" and an associated exhaust stack (TA-41-47) was constructed in 1959. Through the years offices were modified. Portable, window air conditioning units were added, but no major construction appears to have been added.

**List of Drawings (Cntrl + Enter for para break)**

- ENG-C 15125  
Sheet 14 of 75  
Project TA-41, Building W-4  
First Floor Plan  
November 15, 1950
- ENG-C 15126  
Sheet 15 of 75  
Project TA-41, Building W-4  
Second Floor Plan  
November 15, 1950
- ENG-C 15127  
Sheet 16 of 75  
Project TA-41, Building W-4  
Elevations (East, South, and West)  
November 15, 1950  
Field verified and modified January 16, 2002
- ENG-C 15128  
Sheet 17 of 75  
Project TA-41, Building W-4  
Elevations & Sections (North)  
November 15, 1950
- ENG-C 23858  
Sheet 14 of 50  
TA-41, W-4 Annex  
Architectural  
First and Second Floor  
Plans and Schedules  
August 19, 1959
- ENG-C 23861  
Sheet 17 of 50  
TA-41, W-4 Annex  
Architectural  
Elevations and Sections  
August 19, 1959
- ENG-AB 120  
Sheet 1 of 3  
TA-41, Building 4  
As-Built Record Floor Plan  
Architectural  
Basement Floor Plan  
May 13, 1994

Drawings continued on next page

ENG-AB 120  
Sheet 2 of 3  
TA-41, Building 4  
As-Built Record Floor Plan  
Architectural  
First Floor Plan  
May 13, 1994

ENG-AB 120  
Sheet 3 of 3  
TA-41, Building 4  
AS-Built Record Floor Plan  
Architectural  
Second Floor Plan  
May 13, 1994

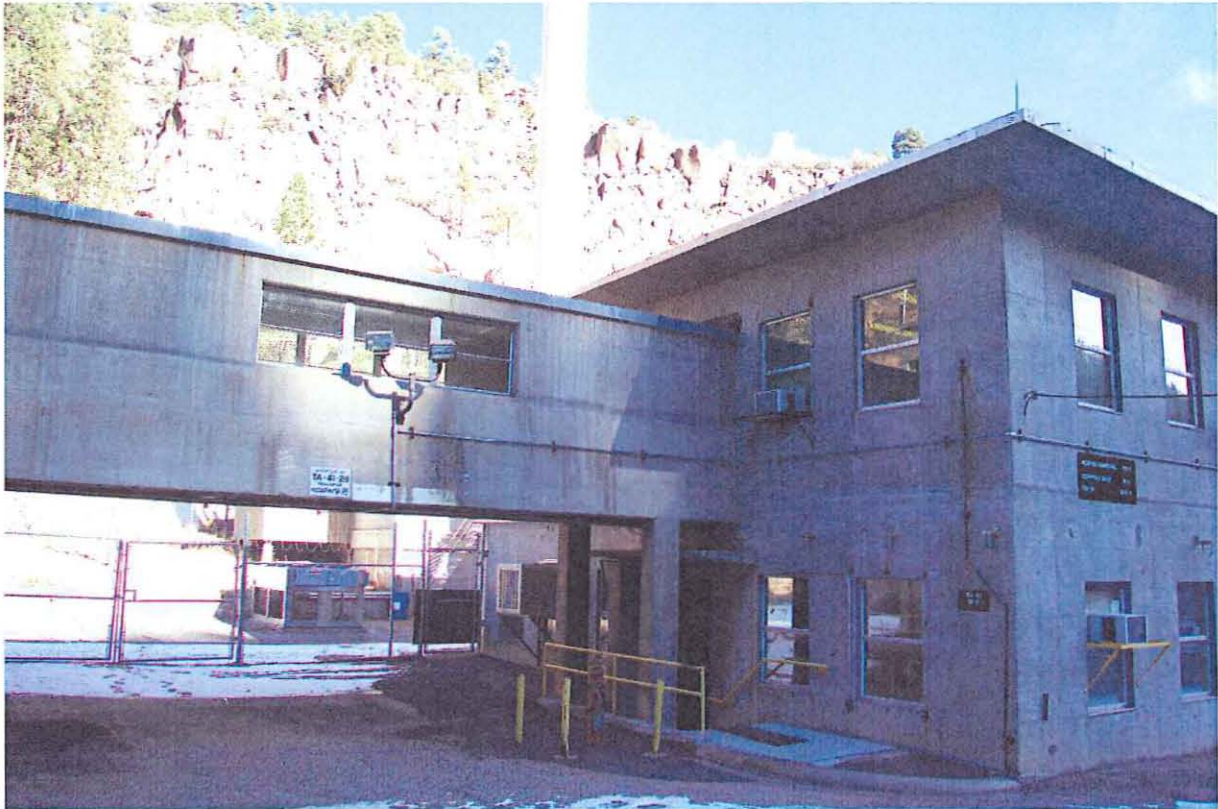

TA-41-4 Laboratory and Office Building, West and South Elevations

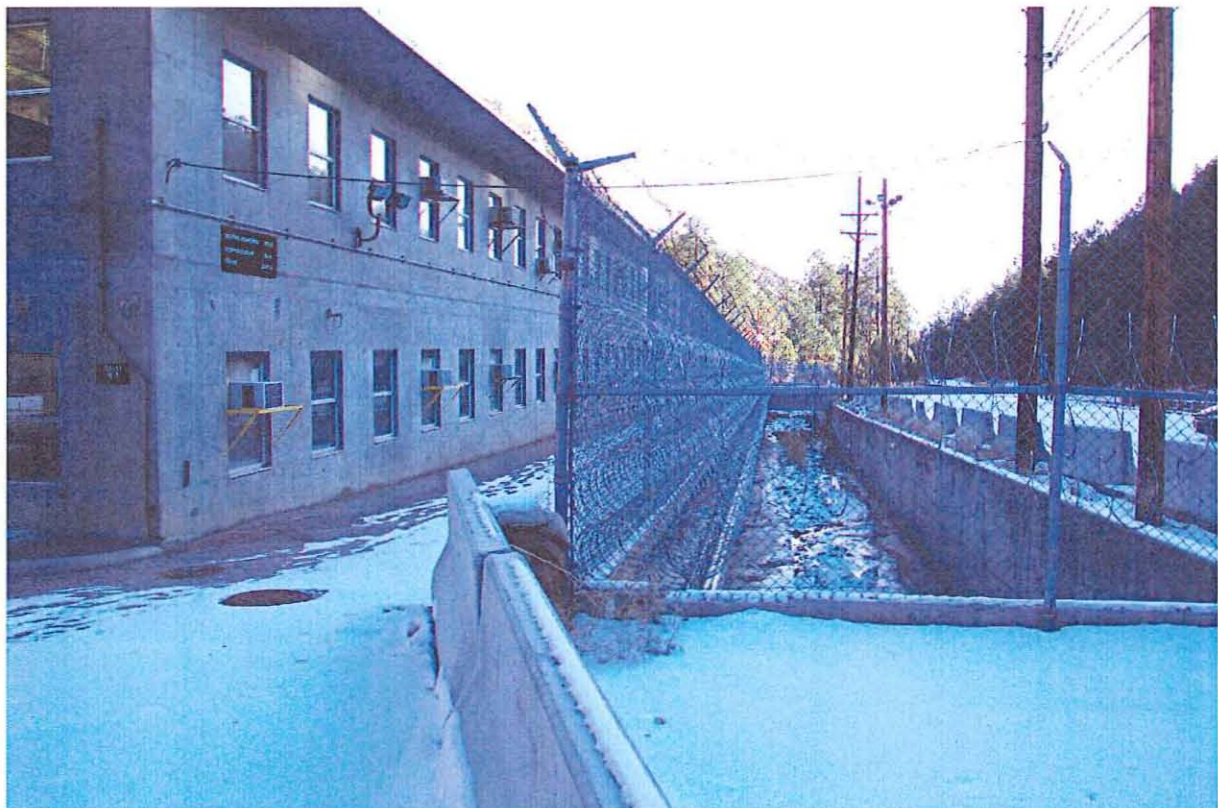

TA-41-4 Laboratory and Office Building, South Elevation



TA-41-4 Laboratory and Office Building, South and East Elevations

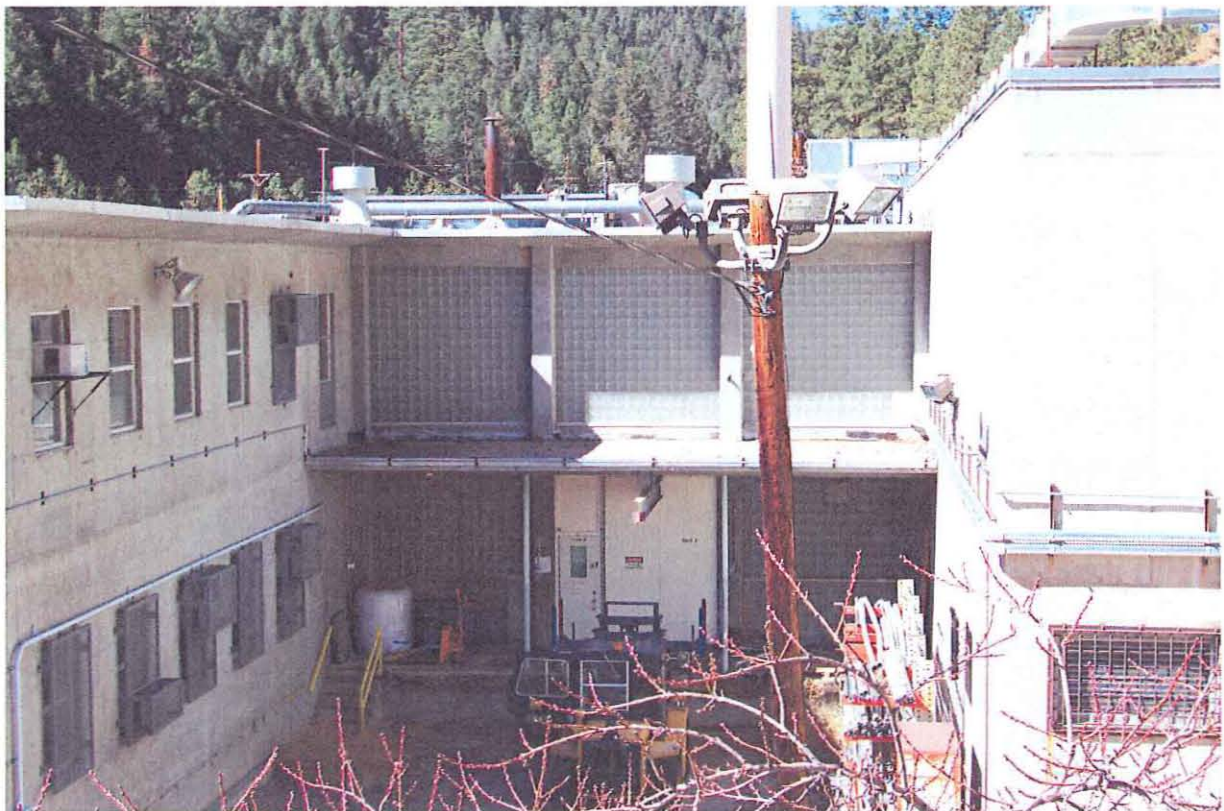

TA-41-4 Laboratory and Office Building, East Elevation



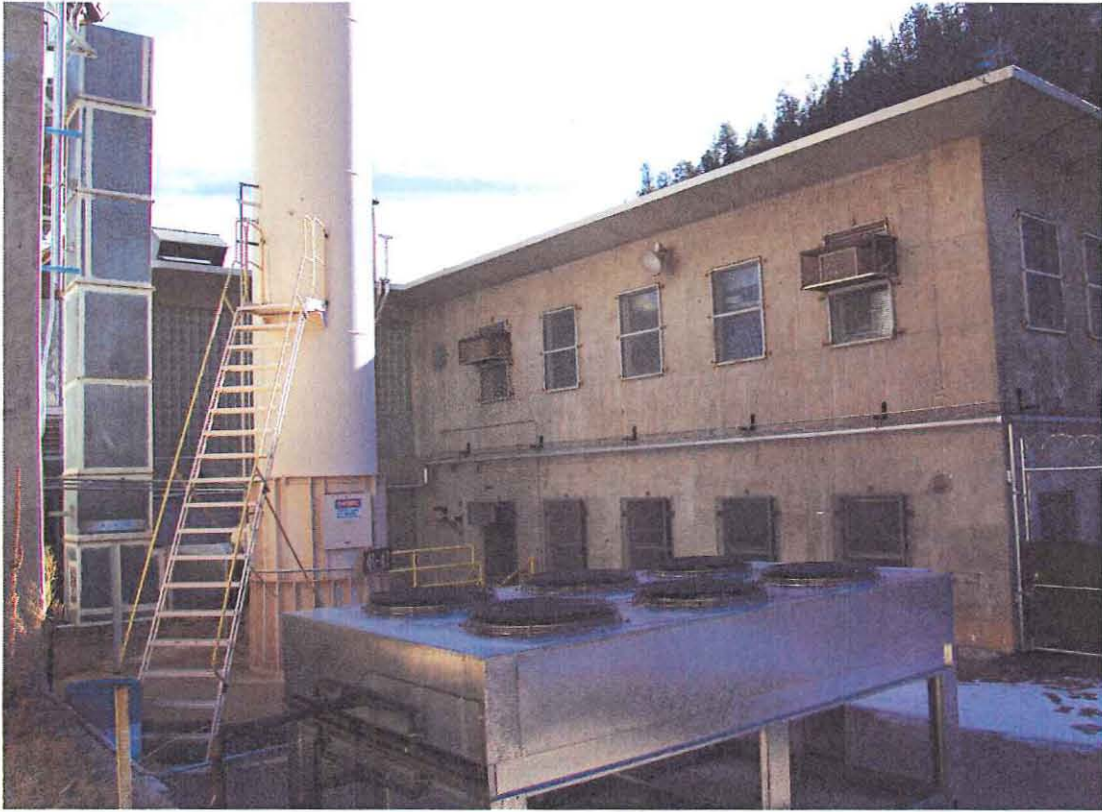

TA-41-4 Laboratory and Office Building, North Elevation of South Wing

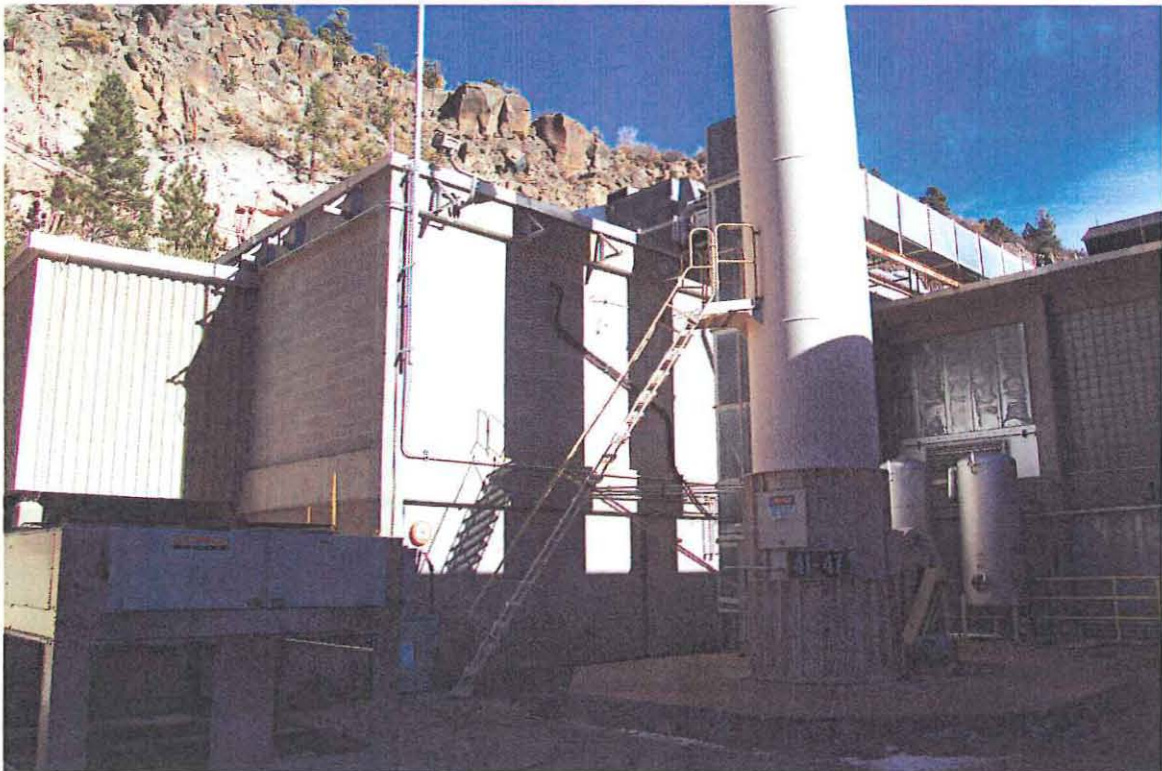

TA-41-4 Laboratory and Office Building, South Elevation of North Wing

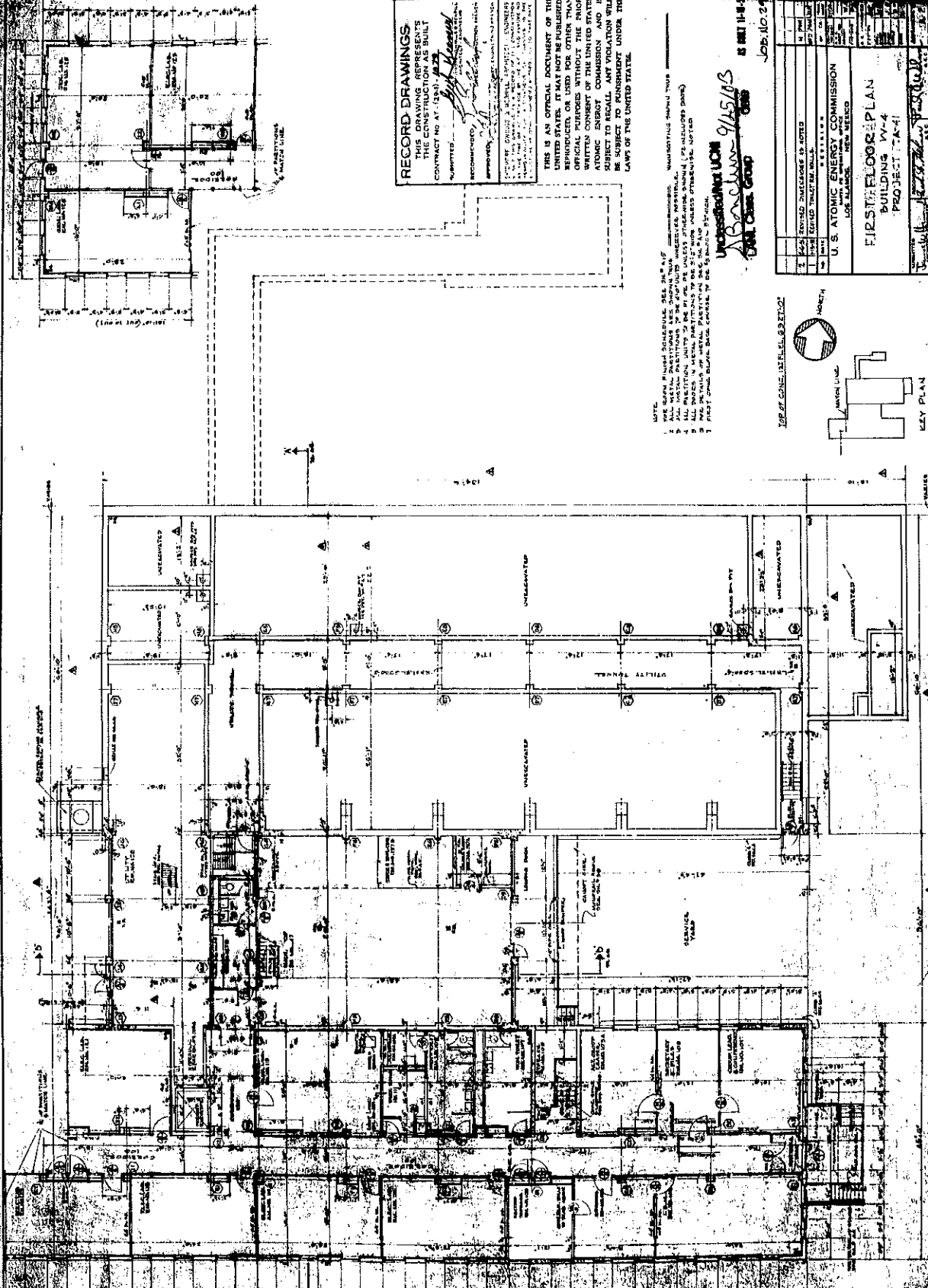

**RECORD DRAWINGS**  
 THIS SET OF RECORD DRAWINGS IS THE CONSTRUCTION AS BUILT DRAWING FOR THE PROJECT.  
 CONTRACT NO. AT-1234-1234  
 SUBMITTED BY: *[Signature]*  
 APPROVED BY: *[Signature]*  
 DATE: 12/31/2023

THIS IS AN OFFICIAL DOCUMENT OF THE UNITED STATES. IT MAY NOT BE REPRODUCED OR USED FOR OTHER THAN OFFICIAL PURPOSES WITHOUT THE PRIOR WRITTEN PERMISSION OF THE UNITED STATES ATOMIC ENERGY COMMISSION. NO IS SUBJECT TO RECALL. ANY VIOLATION WILL BE SUBJECT TO PUNISHMENT UNDER THE LAWS OF THE UNITED STATES.

NOTE:  
 1. ALL WORK SHALL BE IN ACCORDANCE WITH THE LATEST EDITIONS OF THE U.S. GOVERNMENT PRINTING OFFICE (GPO) STANDARDS.  
 2. ALL MATERIALS SHALL BE OF THE HIGHEST QUALITY AND SHALL BE SUBJECT TO INSPECTION AND TESTING BY THE ARCHITECT.  
 3. ALL WORK SHALL BE COMPLETED WITHIN THE SPECIFIED TIME FRAME.  
 4. THE CONTRACTOR SHALL BE RESPONSIBLE FOR OBTAINING ALL NECESSARY PERMITS AND APPROVALS.  
 5. THE CONTRACTOR SHALL MAINTAIN ACCESS TO ALL ADJACENT PROPERTIES AT ALL TIMES.

UNIVERSITY OF CALIFORNIA  
 CIVIL ENGINEERING GROUP

DATE: 12/31/2023  
 JOB NO. 1234

U.S. ATOMIC ENERGY COMMISSION LOS ALAMOS, NEW MEXICO	PROJECT: W-4 BUILDING W-4 PROJECT W-4-1
SKIDMORE OWINGS & MERRILL ARCHITECTS	DATE: 12/31/2023

FOR OFFICIAL USE ONLY

FIRST FLOOR PLAN  
 SCALE: 1/8" = 1'-0"

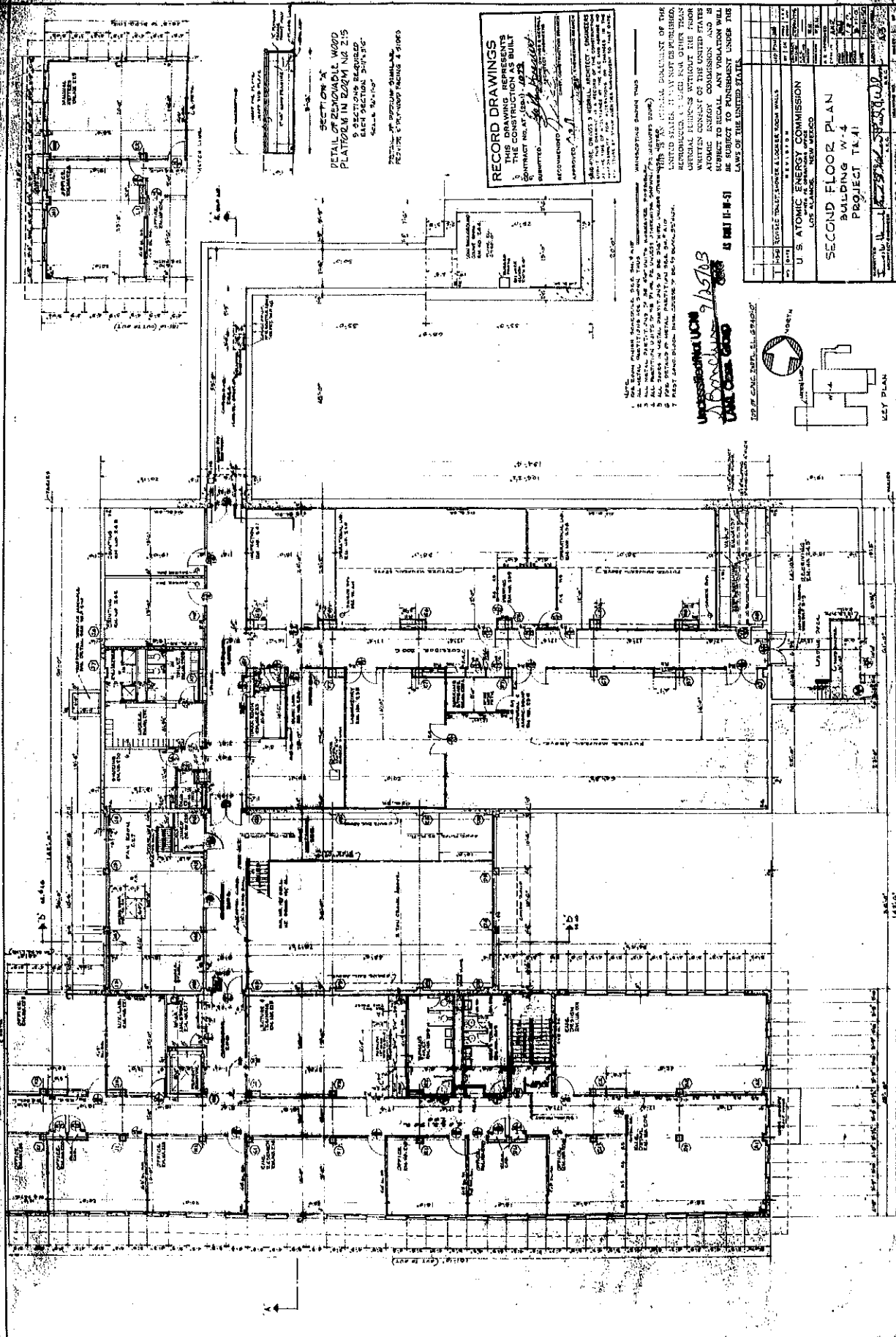

SECTION 2X  
 DETAIL OF PENNYBALL WOOD  
 PLATFORM IN ROOM NO. 215  
 9 SECTIONS REQUIRED  
 EACH SECTION 50"x50"  
 SCALE 3/8"=1'-0"

**RECORD DRAWINGS**  
 THIS DRAWING REPRESENTS  
 THE CONSTRUCTION TO BE  
 INSTALLED AT THE PROJECT  
 APPROVED: [Signature]  
 ARCHITECT: [Signature]  
 CONTRACT NO. AT-11-15  
 DATE: [Date]

MANUFACTURER'S SHOW THIS  
 DRAWING TO THE MANUFACTURER  
 OF THE MATERIALS TO BE USED  
 IN THE CONSTRUCTION OF THE  
 BUILDING TO OBTAIN THE  
 NECESSARY APPROVALS  
 BEFORE THE MATERIALS ARE  
 USED IN THE CONSTRUCTION  
 OF THE BUILDING.

NO.	DATE	DESCRIPTION	BY
1	10/15/53	ISSUED FOR PERMIT	W.S. WALKER
2	11/15/53	ISSUED FOR CONSTRUCTION	W.S. WALKER
3	12/15/53	ISSUED FOR RECORD	W.S. WALKER
4	1/15/54	ISSUED FOR RECORD	W.S. WALKER
5	2/15/54	ISSUED FOR RECORD	W.S. WALKER
6	3/15/54	ISSUED FOR RECORD	W.S. WALKER
7	4/15/54	ISSUED FOR RECORD	W.S. WALKER
8	5/15/54	ISSUED FOR RECORD	W.S. WALKER
9	6/15/54	ISSUED FOR RECORD	W.S. WALKER
10	7/15/54	ISSUED FOR RECORD	W.S. WALKER
11	8/15/54	ISSUED FOR RECORD	W.S. WALKER
12	9/15/54	ISSUED FOR RECORD	W.S. WALKER

**U.S. ATOMIC ENERGY COMMISSION**  
 LOS ALAMOS, NEW MEXICO

**SECOND FLOOR PLAN**  
 BUILDING W-4  
 PROJECT TR-41



UNLESS OTHERWISE SPECIFIED,  
 ALL DIMENSIONS ARE IN FEET AND INCHES.  
 DIMENSIONS IN PARENTHESES ARE  
 TO BE USED IN CASE OF CONFLICT.  
 ALL WORK IS TO BE DONE IN ACCORDANCE  
 WITH THE LATEST EDITIONS OF THE  
 BUILDING CODES AND SPECIFICATIONS  
 OF THE U.S. DEPARTMENT OF COMMERCE,  
 BUREAU OF STANDARDS.

MANUFACTURER'S SHOW THIS  
 DRAWING TO THE MANUFACTURER  
 OF THE MATERIALS TO BE USED  
 IN THE CONSTRUCTION OF THE  
 BUILDING TO OBTAIN THE  
 NECESSARY APPROVALS  
 BEFORE THE MATERIALS ARE  
 USED IN THE CONSTRUCTION  
 OF THE BUILDING.

LOUVEZ ELEVATION	
MARK	DESCRIPTION
1	...
2	...
3	...
4	...
5	...
6	...
7	...
8	...
9	...
10	...
11	...
12	...
13	...
14	...
15	...
16	...
17	...
18	...
19	...
20	...
21	...
22	...
23	...
24	...
25	...
26	...
27	...
28	...
29	...
30	...
31	...
32	...
33	...
34	...
35	...
36	...
37	...
38	...
39	...
40	...
41	...
42	...
43	...
44	...
45	...
46	...
47	...
48	...
49	...
50	...

NOTE: ...

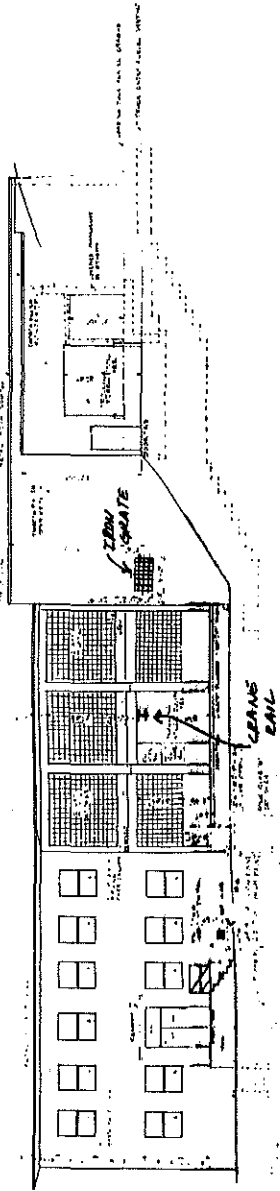

EAST ELEVATION

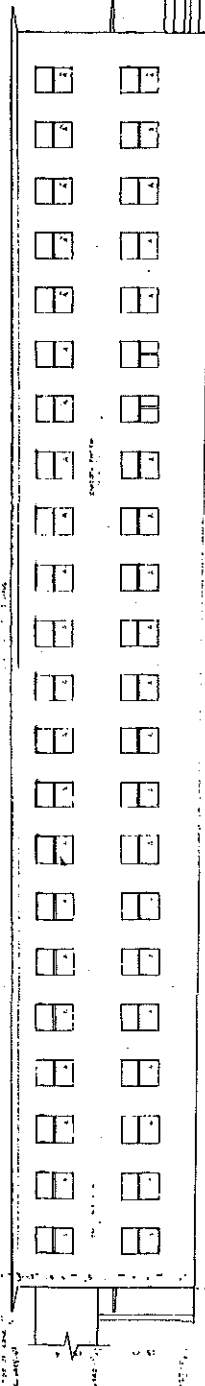

SOUTH ELEVATION

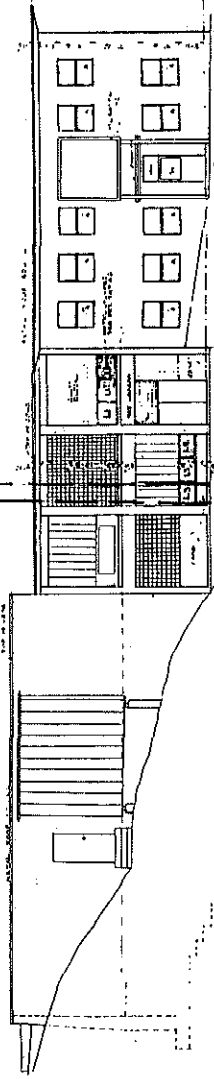

WEST ELEVATION

FIGS. 1, 2, 3, 4, 5, 6, 7, 8, 9, 10, 11, 12, 13, 14, 15, 16, 17, 18, 19, 20, 21, 22, 23, 24, 25, 26, 27, 28, 29, 30, 31, 32, 33, 34, 35, 36, 37, 38, 39, 40, 41, 42, 43, 44, 45, 46, 47, 48, 49, 50, 51, 52, 53, 54, 55, 56, 57, 58, 59, 60, 61, 62, 63, 64, 65, 66, 67, 68, 69, 70, 71, 72, 73, 74, 75, 76, 77, 78, 79, 80, 81, 82, 83, 84, 85, 86, 87, 88, 89, 90, 91, 92, 93, 94, 95, 96, 97, 98, 99, 100, 101, 102, 103, 104, 105, 106, 107, 108, 109, 110, 111, 112, 113, 114, 115, 116, 117, 118, 119, 120, 121, 122, 123, 124, 125, 126, 127, 128, 129, 130, 131, 132, 133, 134, 135, 136, 137, 138, 139, 140, 141, 142, 143, 144, 145, 146, 147, 148, 149, 150, 151, 152, 153, 154, 155, 156, 157, 158, 159, 160, 161, 162, 163, 164, 165, 166, 167, 168, 169, 170, 171, 172, 173, 174, 175, 176, 177, 178, 179, 180, 181, 182, 183, 184, 185, 186, 187, 188, 189, 190, 191, 192, 193, 194, 195, 196, 197, 198, 199, 200, 201, 202, 203, 204, 205, 206, 207, 208, 209, 210, 211, 212, 213, 214, 215, 216, 217, 218, 219, 220, 221, 222, 223, 224, 225, 226, 227, 228, 229, 230, 231, 232, 233, 234, 235, 236, 237, 238, 239, 240, 241, 242, 243, 244, 245, 246, 247, 248, 249, 250, 251, 252, 253, 254, 255, 256, 257, 258, 259, 260, 261, 262, 263, 264, 265, 266, 267, 268, 269, 270, 271, 272, 273, 274, 275, 276, 277, 278, 279, 280, 281, 282, 283, 284, 285, 286, 287, 288, 289, 290, 291, 292, 293, 294, 295, 296, 297, 298, 299, 300, 301, 302, 303, 304, 305, 306, 307, 308, 309, 310, 311, 312, 313, 314, 315, 316, 317, 318, 319, 320, 321, 322, 323, 324, 325, 326, 327, 328, 329, 330, 331, 332, 333, 334, 335, 336, 337, 338, 339, 340, 341, 342, 343, 344, 345, 346, 347, 348, 349, 350, 351, 352, 353, 354, 355, 356, 357, 358, 359, 360, 361, 362, 363, 364, 365, 366, 367, 368, 369, 370, 371, 372, 373, 374, 375, 376, 377, 378, 379, 380, 381, 382, 383, 384, 385, 386, 387, 388, 389, 390, 391, 392, 393, 394, 395, 396, 397, 398, 399, 400, 401, 402, 403, 404, 405, 406, 407, 408, 409, 410, 411, 412, 413, 414, 415, 416, 417, 418, 419, 420, 421, 422, 423, 424, 425, 426, 427, 428, 429, 430, 431, 432, 433, 434, 435, 436, 437, 438, 439, 440, 441, 442, 443, 444, 445, 446, 447, 448, 449, 450, 451, 452, 453, 454, 455, 456, 457, 458, 459, 460, 461, 462, 463, 464, 465, 466, 467, 468, 469, 470, 471, 472, 473, 474, 475, 476, 477, 478, 479, 480, 481, 482, 483, 484, 485, 486, 487, 488, 489, 490, 491, 492, 493, 494, 495, 496, 497, 498, 499, 500, 501, 502, 503, 504, 505, 506, 507, 508, 509, 510, 511, 512, 513, 514, 515, 516, 517, 518, 519, 520, 521, 522, 523, 524, 525, 526, 527, 528, 529, 530, 531, 532, 533, 534, 535, 536, 537, 538, 539, 540, 541, 542, 543, 544, 545, 546, 547, 548, 549, 550, 551, 552, 553, 554, 555, 556, 557, 558, 559, 560, 561, 562, 563, 564, 565, 566, 567, 568, 569, 570, 571, 572, 573, 574, 575, 576, 577, 578, 579, 580, 581, 582, 583, 584, 585, 586, 587, 588, 589, 590, 591, 592, 593, 594, 595, 596, 597, 598, 599, 600, 601, 602, 603, 604, 605, 606, 607, 608, 609, 610, 611, 612, 613, 614, 615, 616, 617, 618, 619, 620, 621, 622, 623, 624, 625, 626, 627, 628, 629, 630, 631, 632, 633, 634, 635, 636, 637, 638, 639, 640, 641, 642, 643, 644, 645, 646, 647, 648, 649, 650, 651, 652, 653, 654, 655, 656, 657, 658, 659, 660, 661, 662, 663, 664, 665, 666, 667, 668, 669, 670, 671, 672, 673, 674, 675, 676, 677, 678, 679, 680, 681, 682, 683, 684, 685, 686, 687, 688, 689, 690, 691, 692, 693, 694, 695, 696, 697, 698, 699, 700, 701, 702, 703, 704, 705, 706, 707, 708, 709, 710, 711, 712, 713, 714, 715, 716, 717, 718, 719, 720, 721, 722, 723, 724, 725, 726, 727, 728, 729, 730, 731, 732, 733, 734, 735, 736, 737, 738, 739, 740, 741, 742, 743, 744, 745, 746, 747, 748, 749, 750, 751, 752, 753, 754, 755, 756, 757, 758, 759, 760, 761, 762, 763, 764, 765, 766, 767, 768, 769, 770, 771, 772, 773, 774, 775, 776, 777, 778, 779, 780, 781, 782, 783, 784, 785, 786, 787, 788, 789, 790, 791, 792, 793, 794, 795, 796, 797, 798, 799, 800, 801, 802, 803, 804, 805, 806, 807, 808, 809, 810, 811, 812, 813, 814, 815, 816, 817, 818, 819, 820, 821, 822, 823, 824, 825, 826, 827, 828, 829, 830, 831, 832, 833, 834, 835, 836, 837, 838, 839, 840, 841, 842, 843, 844, 845, 846, 847, 848, 849, 850, 851, 852, 853, 854, 855, 856, 857, 858, 859, 860, 861, 862, 863, 864, 865, 866, 867, 868, 869, 870, 871, 872, 873, 874, 875, 876, 877, 878, 879, 880, 881, 882, 883, 884, 885, 886, 887, 888, 889, 890, 891, 892, 893, 894, 895, 896, 897, 898, 899, 900, 901, 902, 903, 904, 905, 906, 907, 908, 909, 910, 911, 912, 913, 914, 915, 916, 917, 918, 919, 920, 921, 922, 923, 924, 925, 926, 927, 928, 929, 930, 931, 932, 933, 934, 935, 936, 937, 938, 939, 940, 941, 942, 943, 944, 945, 946, 947, 948, 949, 950, 951, 952, 953, 954, 955, 956, 957, 958, 959, 960, 961, 962, 963, 964, 965, 966, 967, 968, 969, 970, 971, 972, 973, 974, 975, 976, 977, 978, 979, 980, 981, 982, 983, 984, 985, 986, 987, 988, 989, 990, 991, 992, 993, 994, 995, 996, 997, 998, 999, 1000.

RECORD DRAWINGS  
THIS DRAWING REPRESENTS  
THE CONDITION AS BUILT  
CONTRACT NO. 100-100-100  
DATE 10/10/50

NO.	DATE	BY	DESCRIPTION
1	10/10/50	J. H. ...	...
2	...	...	...
3	...	...	...
4	...	...	...
5	...	...	...
6	...	...	...
7	...	...	...
8	...	...	...
9	...	...	...
10	...	...	...
11	...	...	...
12	...	...	...
13	...	...	...
14	...	...	...
15	...	...	...
16	...	...	...
17	...	...	...
18	...	...	...
19	...	...	...
20	...	...	...
21	...	...	...
22	...	...	...
23	...	...	...
24	...	...	...
25	...	...	...
26	...	...	...
27	...	...	...
28	...	...	...
29	...	...	...
30	...	...	...
31	...	...	...
32	...	...	...
33	...	...	...
34	...	...	...
35	...	...	...
36	...	...	...
37	...	...	...
38	...	...	...
39	...	...	...
40	...	...	...
41	...	...	...
42	...	...	...
43	...	...	...
44	...	...	...
45	...	...	...
46	...	...	...
47	...	...	...
48	...	...	...
49	...	...	...
50	...	...	...
51	...	...	...
52	...	...	...
53	...	...	...
54	...	...	...
55	...	...	...
56	...	...	...
57	...	...	...
58	...	...	...
59	...	...	...
60	...	...	...
61	...	...	...
62	...	...	...
63	...	...	...
64	...	...	...
65	...	...	...
66	...	...	...
67	...	...	...
68	...	...	...
69	...	...	...
70	...	...	...
71	...	...	...
72	...	...	...
73	...	...	...
74	...	...	...
75	...	...	...
76	...	...	...
77	...	...	...
78	...	...	...
79	...	...	...
80	...	...	...
81	...	...	...
82	...	...	...
83	...	...	...
84	...	...	...
85	...	...	...
86	...	...	...
87	...	...	...
88	...	...	...
89	...	...	...
90	...	...	...
91	...	...	...
92	...	...	...
93	...	...	...
94	...	...	...
95	...	...	...
96	...	...	...
97	...	...	...
98	...	...	...
99	...	...	...
100	...	...	...

THIS IS AN ORIGINAL DOCUMENT OF THE  
UNITED STATES. IT MAY NOT BE PUBLISHED,  
REPRODUCED OR USED FOR OTHER THAN  
OFFICIAL PURPOSES WITHOUT THE WRITTEN  
CONSENT OF THE UNITED STATES  
ATOMIC ENERGY COMMISSION AND IS  
SUBJECT TO RECALL AND FORFEITURE. IT  
IS SUBJECT TO THE PROVISIONS OF THE  
LAWS OF THE UNITED STATES.

UNCLASSIFIED UCM  
DATE 9/25/83  
BY [Signature]  
DART CLASS GROUP

FOR OFFICIAL USE ONLY

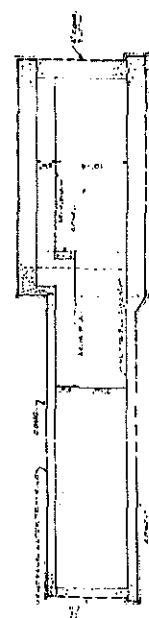

SECTION AT A-A

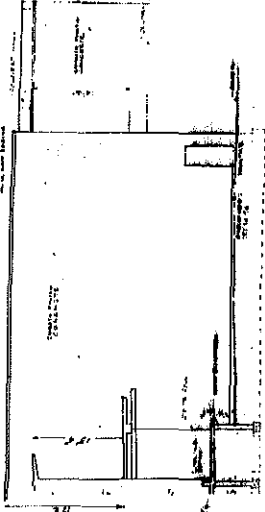

SOUTH COURT ELEVATION

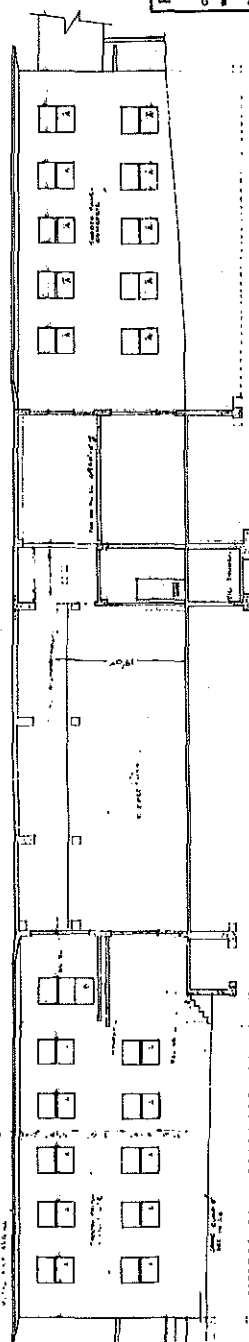

NORTH COURT ELEVATION & SECTION

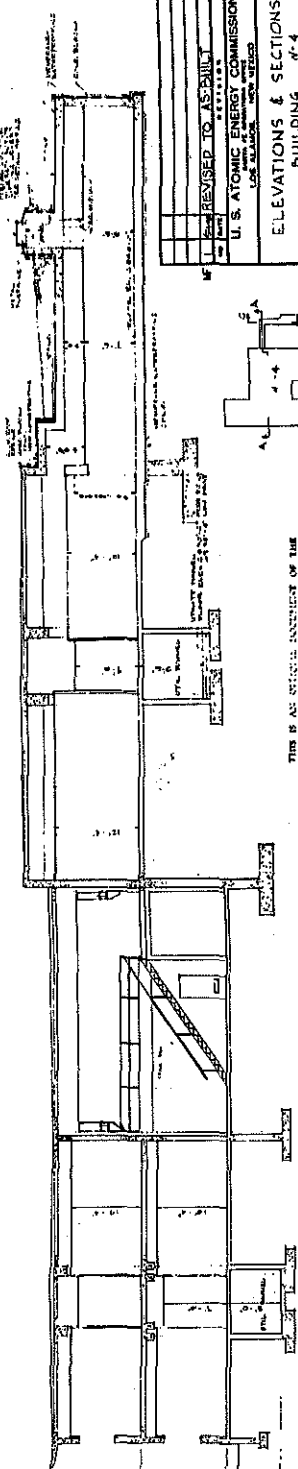

SECTION AT A-A

REVISIONS  
 1. REVISED TO AS-BUILT  
 2. REVISED TO AS-BUILT  
 3. REVISED TO AS-BUILT  
 4. REVISED TO AS-BUILT  
 5. REVISED TO AS-BUILT

RECORD DRAWINGS  
 OF THE BUILDING  
 THE CONTRACTOR HAS BUILT  
 CONTRACT NO. 1-1537-2273  
 DRAWN BY: J. H. Hagan  
 CHECKED BY: J. H. Hagan  
 APPROVED BY: J. H. Hagan  
 DATE: 10/1/53

NO.	DATE	BY	DESCRIPTION
1	10/1/53	J. H. Hagan	AS-BUILT
2	10/1/53	J. H. Hagan	AS-BUILT
3	10/1/53	J. H. Hagan	AS-BUILT
4	10/1/53	J. H. Hagan	AS-BUILT
5	10/1/53	J. H. Hagan	AS-BUILT

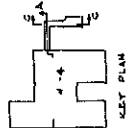

THIS IS AN OFFICIAL INSTRUMENT OF THE U.S. ATOMIC ENERGY COMMISSION. IT IS HEREBY CERTIFIED THAT IT IS A TRUE AND CORRECT COPY OF THE ORIGINAL INSTRUMENTS WITHIN THE PROVISIONS OF THE ATOMIC ENERGY ACT AND IS SUBJECT TO REGULATION AND CONTROL UNDER THE LAWS OF THE UNITED STATES.

FOR OFFICIAL USE ONLY

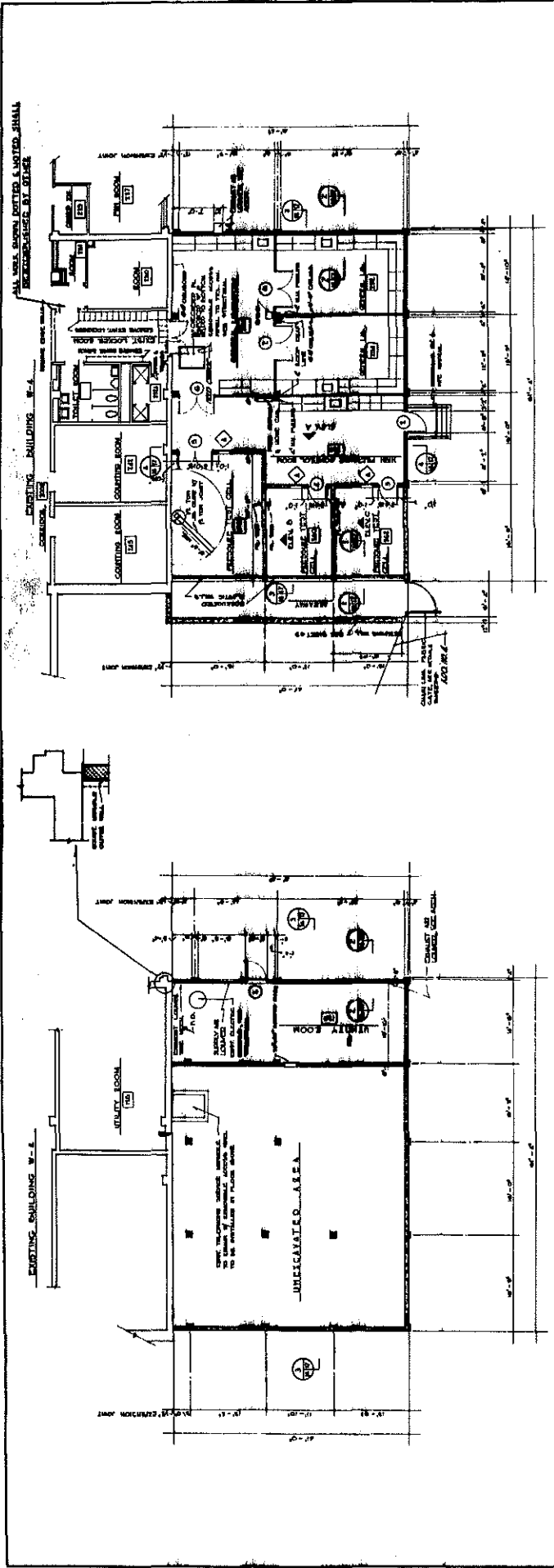

FIRST FLOOR PLAN  
S. S. L. E. 1

SECOND FLOOR PLAN  
S. S. L. E. 1

- ASSUMPTIONS:
- CHANGES
  - EXISTING
  - FLOOR DRAIN
  - FINISH
  - ANCHORS
  - ACCESSIBILITY
  - A.U.
  - CONTRACT
  - TEL. ROOM

NOTE:  
PLACE LEVEL OF FINISH, FLOOR  
FINISH, CONSTRUCTION, DIMENSIONS  
ON V.P. SHEET.

AS CONSTRUCTED DRAWING  
CONTRACT NO. JEP-4-847  
DATE: 5/25/04  
APPROVED: [Signature]

U.S. ATOMIC ENERGY COMMISSION LABORATORY BUILDING ARCHITECTURAL PLANS & SCHEDULES TA-41	
DATE: 5/25/04	SCALE: 1/8" = 1'-0"
PROJECT: TA-41	NO. OF SHEETS: 14
SHEET: 14	DATE: 5/25/04

DOOR SCHEDULE

ROOM NO.	DOOR TYPE	FINISH	SET	LOCK	NOTIFICATION
1	M	30-3	METAL	B	
2	M	30-3	METAL	B	
3	P	20-2		9-11	945
4	P	20-2		9-11	1000
5	P	20-2		9-11	1000
6	P	20-2		9-11	1000
7	P	20-2		9-11	1000
8	P	20-2		9-11	1000

ROOM FINISH SCHEDULE

ROOM NO.	ROOM NAME	FLOOR	WALL	CEILING	FINISHES
100	UTILITY ROOM	C	C	C	C
101	GENERAL LABORATORY	A-E	C	C	C
102	GENERAL LABORATORY	A-E	C	C	C
103	GENERAL LABORATORY	A-E	C	C	C
104	GENERAL LABORATORY	A-E	C	C	C
105	GENERAL LABORATORY	A-E	C	C	C
106	GENERAL LABORATORY	A-E	C	C	C
107	GENERAL LABORATORY	A-E	C	C	C
108	GENERAL LABORATORY	A-E	C	C	C
109	GENERAL LABORATORY	A-E	C	C	C
110	GENERAL LABORATORY	A-E	C	C	C
111	GENERAL LABORATORY	A-E	C	C	C
112	GENERAL LABORATORY	A-E	C	C	C
113	GENERAL LABORATORY	A-E	C	C	C
114	GENERAL LABORATORY	A-E	C	C	C
115	GENERAL LABORATORY	A-E	C	C	C
116	GENERAL LABORATORY	A-E	C	C	C
117	GENERAL LABORATORY	A-E	C	C	C
118	GENERAL LABORATORY	A-E	C	C	C
119	GENERAL LABORATORY	A-E	C	C	C
120	GENERAL LABORATORY	A-E	C	C	C

DOES NOT CONTAIN  
OFFICIAL USE ONLY INFORMATION  
Name/Org.: Jill Hefels-7 Date: 5/25/04



**ROOM INFORMATION CHART**

RM NO	AREA SQ FT	PERCENTAGE	RM NO	AREA SQ FT	PERCENTAGE
1	2,278	6.1	2	2,278	6.1
2	2,278	6.1	3	2,278	6.1
3	2,278	6.1	4	2,278	6.1
4	2,278	6.1	5	2,278	6.1
5	2,278	6.1	6	2,278	6.1
6	2,278	6.1	7	2,278	6.1
7	2,278	6.1	8	2,278	6.1
8	2,278	6.1	9	2,278	6.1
9	2,278	6.1	10	2,278	6.1
10	2,278	6.1	11	2,278	6.1
11	2,278	6.1	12	2,278	6.1
12	2,278	6.1	13	2,278	6.1
13	2,278	6.1	14	2,278	6.1
14	2,278	6.1	15	2,278	6.1
15	2,278	6.1	16	2,278	6.1
16	2,278	6.1	17	2,278	6.1
17	2,278	6.1	18	2,278	6.1
18	2,278	6.1	19	2,278	6.1
19	2,278	6.1	20	2,278	6.1
20	2,278	6.1	21	2,278	6.1
21	2,278	6.1	22	2,278	6.1
22	2,278	6.1	23	2,278	6.1
23	2,278	6.1	24	2,278	6.1
24	2,278	6.1	25	2,278	6.1
25	2,278	6.1	26	2,278	6.1
26	2,278	6.1	27	2,278	6.1
27	2,278	6.1	28	2,278	6.1
28	2,278	6.1	29	2,278	6.1
29	2,278	6.1	30	2,278	6.1
30	2,278	6.1	31	2,278	6.1
31	2,278	6.1	32	2,278	6.1
32	2,278	6.1	33	2,278	6.1
33	2,278	6.1	34	2,278	6.1
34	2,278	6.1	35	2,278	6.1
35	2,278	6.1	36	2,278	6.1
36	2,278	6.1	37	2,278	6.1
37	2,278	6.1	38	2,278	6.1
38	2,278	6.1	39	2,278	6.1
39	2,278	6.1	40	2,278	6.1
40	2,278	6.1	41	2,278	6.1
41	2,278	6.1	42	2,278	6.1
42	2,278	6.1	43	2,278	6.1
43	2,278	6.1	44	2,278	6.1
44	2,278	6.1	45	2,278	6.1
45	2,278	6.1	46	2,278	6.1
46	2,278	6.1	47	2,278	6.1
47	2,278	6.1	48	2,278	6.1
48	2,278	6.1	49	2,278	6.1
49	2,278	6.1	50	2,278	6.1
50	2,278	6.1	51	2,278	6.1
51	2,278	6.1	52	2,278	6.1
52	2,278	6.1	53	2,278	6.1
53	2,278	6.1	54	2,278	6.1
54	2,278	6.1	55	2,278	6.1
55	2,278	6.1	56	2,278	6.1
56	2,278	6.1	57	2,278	6.1
57	2,278	6.1	58	2,278	6.1
58	2,278	6.1	59	2,278	6.1
59	2,278	6.1	60	2,278	6.1
60	2,278	6.1	61	2,278	6.1
61	2,278	6.1	62	2,278	6.1
62	2,278	6.1	63	2,278	6.1
63	2,278	6.1	64	2,278	6.1
64	2,278	6.1	65	2,278	6.1
65	2,278	6.1	66	2,278	6.1
66	2,278	6.1	67	2,278	6.1
67	2,278	6.1	68	2,278	6.1
68	2,278	6.1	69	2,278	6.1
69	2,278	6.1	70	2,278	6.1
70	2,278	6.1	71	2,278	6.1
71	2,278	6.1	72	2,278	6.1
72	2,278	6.1	73	2,278	6.1
73	2,278	6.1	74	2,278	6.1
74	2,278	6.1	75	2,278	6.1
75	2,278	6.1	76	2,278	6.1
76	2,278	6.1	77	2,278	6.1
77	2,278	6.1	78	2,278	6.1
78	2,278	6.1	79	2,278	6.1
79	2,278	6.1	80	2,278	6.1
80	2,278	6.1	81	2,278	6.1
81	2,278	6.1	82	2,278	6.1
82	2,278	6.1	83	2,278	6.1
83	2,278	6.1	84	2,278	6.1
84	2,278	6.1	85	2,278	6.1
85	2,278	6.1	86	2,278	6.1
86	2,278	6.1	87	2,278	6.1
87	2,278	6.1	88	2,278	6.1
88	2,278	6.1	89	2,278	6.1
89	2,278	6.1	90	2,278	6.1
90	2,278	6.1	91	2,278	6.1
91	2,278	6.1	92	2,278	6.1
92	2,278	6.1	93	2,278	6.1
93	2,278	6.1	94	2,278	6.1
94	2,278	6.1	95	2,278	6.1
95	2,278	6.1	96	2,278	6.1
96	2,278	6.1	97	2,278	6.1
97	2,278	6.1	98	2,278	6.1
98	2,278	6.1	99	2,278	6.1
99	2,278	6.1	100	2,278	6.1

TOTAL ROOM NET SQUARE FOOTAGE (THIS SHEET) = 2,278  
 GROSS SQUARE FOOTAGE (THIS SHEET) = 2,888  
 TOTAL ROOM NET SQUARE FOOTAGE (BUILDING) = 37,434  
 GROSS SQUARE FOOTAGE (BUILDING) = 40,585

**LEGEND**

- CONCRETE
- COLUMN
- LOUVER
- UTILITY

**NOTES**

1. REFERENCE DIMENSIONS: ENCL-38A-11-28.1.1 AND 18.1.1.50.
2. ROOM NET SQUARE FOOTAGE IS COMPUTED BY MEASURING FROM THE INSIDE FACE OF EXTERIOR WALLS TO THE CENTERLINE OF ALL OTHER WALLS. AREAS SHOWN ARE ROUNDED TO THE NEAREST SQUARE FOOT.
3. GROSS SQUARE FOOTAGE IS EQUAL TO ALL FLOOR AREA INCLUDING THE AREA OF ALL EXTERIOR WALLS, STAIRS, LOBBIES, MEZZANINES, HALLS, VESTIBULES, STAIRWELLS, SERVICE AND EQUIPMENT AREAS, ELEVATOR SHAFTS, MECHANICAL ROOMS, UNFINISHED LOBBY SPACE WITH SLOPING CEILINGS (SUCH AS STAIR SPACES) HAVING 5 FEET OR MORE HEADROOM, AND APPROVED COVERED SHIPPING OR RECEIVING AREAS. THIS INCLUDES ALL FLOOR AREA, BUT EXCLUDES ALL AREAS INCLUDED IN GROSS FLOOR AREA, BUT CALCULATED ON ONE HALF OF ACTUAL FLOOR AREA, ARE COVERED OPEN PORCHES, PASSAGES AND WALLS, WITH APPROVED UNCOVERED RECEIVING AND SHIPPING PLATFORMS AT TRUCK AND RAILROAD HEIGHT.
4. DIMENSIONS SHOWN ARE ROUNDED TO THE NEAREST INCH.

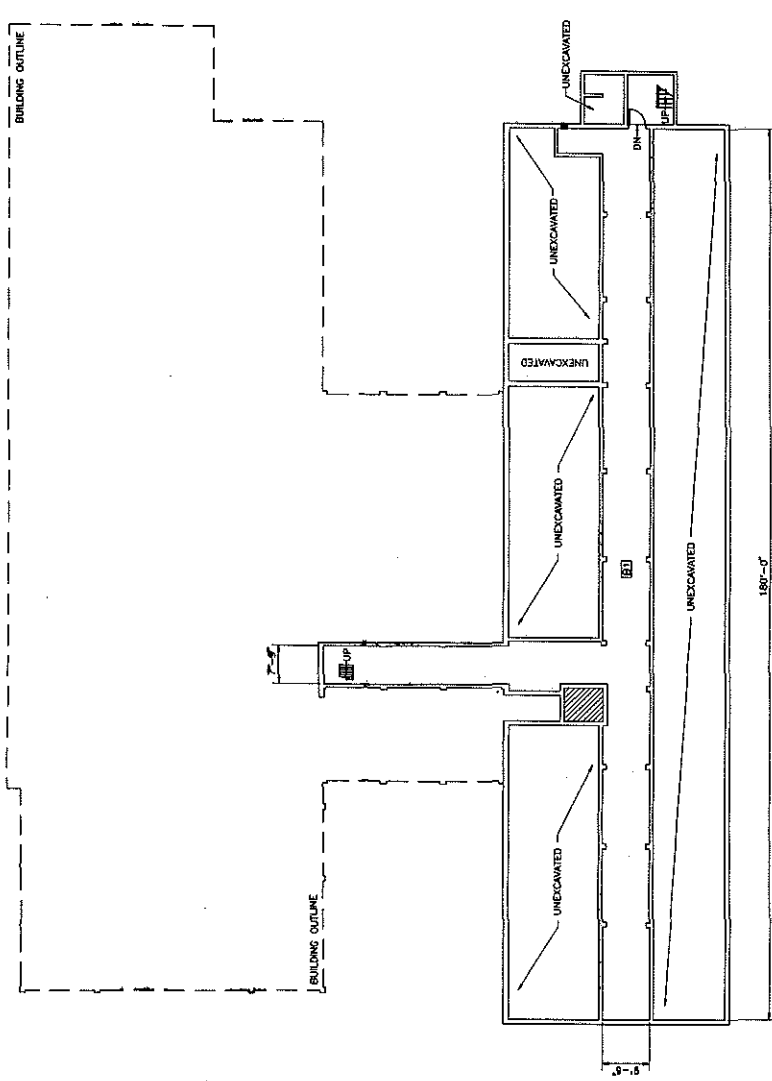

NO	DATE	DESCRIPTION	BY	CHKD	APP

**JOHNSON CONTROLS WORLD SERVICES INC.**

AS-BUILT RECORD FLOOR PLAN  
 LABORATORY BUILDING  
 ARCH: BASEMENT FLOOR PLAN

DATE: 05-13-24  
 DRAWN BY: [Signature]  
 CHECKED BY: [Signature]  
 RELEASED BY: [Signature]

PROJECT NO: 7556  
 DRAWING NO: AB120

REVISIONS: 1. 05/13/24

FIELD VERIFIED 12-02-83

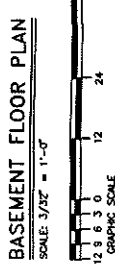







LANL TA- Building # 41-0006

Camera 984242

Frame #s DCP\_0843 & DCP\_0844, DCP\_1093 through DCP\_1097, DCP\_1107 & DCP\_1112

Surveyor(s) J. Ronquillo/K. Towery

Date 03/05/2002

Los Alamos National Laboratory CRMT Historic Building Survey Form

Building Name Covered Passageway UTM's easting 382947 northing 3970885 zone 13

Legal Description: Map Guaje Mountain Quad 1984 tnsr 19N range 6E sec 15

Current Use/ Function Covered Passageway Original Use/ Function Covered Passageway

Date (estimated) 1950 Date (actual) 1951 Property Type Laboratory/Processing

Type of Construction

Pre-Fabricated Metal [ ] Steel Frame [ ] Wood Frame [ ] CMU [ ] Reinforced Concrete [x]

Other Type of Construction Concrete shear walls. # of Stories 1

Foundation Reinforced concrete.

Exterior CMU-Exterior [ ] Reinforced Concrete-Exterior [x] Steel (galvanized) [ ] Steel (corrugated) [ ]

Wood Siding [ ] Asbestos Shingles-Exterior [ ] In-Fill Panels [ ] Other-Exterior [ ]

Exterior Treatment (painted, stuccoed, etc) Unpainted concrete finish.

Exterior Features (docks, speakers, lights, signs, etc) [ ]

Addition CMU-Addition [ ] Reinforced Concrete-Addition [ ] Steel (galvanized)- Addition [ ] Wood [ ]

Steel (corrugated)-Addition [ ] Asbestos Shingles-Addition [ ] Other- Addition [ ]

Exterior Treatment-Addition N/A

Exterior Features-Addition [ ]

Roof Form Slanted/Shed [ ] Gable [ ] Other Roof Type Slight pitch.

Degree of Pitch/ Slope Slight

Roof Materials Corrugated Metal [ ] Rolled Asphalt [ ] Asbestos Shingles [ ] 4-Ply Built Up [ ]

Other Roof Materials Concrete

Window Type Casement [ ] Single Hung Sash [ ] Double Hung Sash [ ] Fixed Window [x]

Other Window Type N/A

# of Each Window Type/ Comments [ ]

Glass Type Clear [x] Wire Glass [x] Opaque [ ] Painted Glass [ ] Glass Block [ ]

Light Pattern [ ]

Door Type Personnel Door Types Exterior Fire Door [ ] Single [x] Double [ ] Roll-up [ ] Sliding [ ]

		Hollow Metal <input checked="" type="checkbox"/>	Solid Wood <input type="checkbox"/>	1/2 Glazed <input type="checkbox"/>	Paneled <input type="checkbox"/>	
		Louvered <input type="checkbox"/>	Painted <input type="checkbox"/>			
	Interior	Fire Door <input type="checkbox"/>	Single <input type="checkbox"/>	Double <input type="checkbox"/>	Roll-up <input type="checkbox"/>	Sliding <input type="checkbox"/>
		Hollow Metal <input type="checkbox"/>	Solid Wood <input type="checkbox"/>	1/2 Glazed <input type="checkbox"/>	Paneled <input type="checkbox"/>	
		Louvered <input type="checkbox"/>	Painted <input type="checkbox"/>			
Equipment Door Types	Exterior	Fire Door <input type="checkbox"/>	Single <input type="checkbox"/>	Double <input type="checkbox"/>	Roll-up <input type="checkbox"/>	Sliding <input type="checkbox"/>
		Hollow Metal <input type="checkbox"/>	Solid Wood <input type="checkbox"/>	1/2 Glazed <input type="checkbox"/>	Paneled <input type="checkbox"/>	
		Louvered <input type="checkbox"/>	Painted <input type="checkbox"/>			
	Interior	Fire Door <input type="checkbox"/>	Single <input type="checkbox"/>	Double <input type="checkbox"/>	Roll-up <input type="checkbox"/>	Sliding <input type="checkbox"/>
		Hollow Metal <input type="checkbox"/>	Solid Metal <input type="checkbox"/>	1/2 Glazed <input type="checkbox"/>	Paneled <input type="checkbox"/>	
		Louvered <input type="checkbox"/>	Painted <input type="checkbox"/>			

# of Each Door Type/Comments:

**Interior Wall** Gypsum Board  Reinforced Concrete- Interior

CMU- Interior  Plywood  Other- Interior

In-Wall Electrical Wiring  On-Wall Electrical Wiring

**Ceiling** Drop Ceiling

Interior Comments (Equipment, etc)

**Degree of Remodeling**

**Condition** Excellent  Good  Fair  Deteriorating  Contaminated  Burned

**Associated Building**

If yes, list building names and #s:

**Integrity**

**Significance**

**Eligible Under Criterion** A  B  C  D  Not Eligible

**DOE Themes**

Nuclear Weapon Components and Assembly  Nuclear Weapon Design and Testing  Nuclear Propulsion

Peaceful Uses: Plowshare, Nuclear Medicine, Nuclear Energy, Nuclear Science  Energy and Environment: Research Design Projects

**LANL Themes**

Weapons Research and Design, Testing, and Stockpile Support  Super Computing

Reactor Technology  Biomedical/Health Physics  Strategic and Supporting Research

Environment/Waste Management  Administration and Social History  Architectural History

**Recommendations/ Additional Comments**

**Architectural Features (elevations)**

Metal panels on metals.

**Total sq ft** 938 Gross

**Architect/ Builder** R.E. McKee

**Alterations**

A guard station was attached toward the eastern end of the covered passageway in 1985.

**List of Drawings (Ctrl + Enter for para break)**

ENG-C 15141  
Sheet 30 of 75  
Project TA-41, Building W-6  
Plans, Elevations & Details  
November 28, 1950

ENG-R 3143  
Covered Passageway  
TA-41, Passageway W-6  
Floor Plan  
September 28, 1983  
Revised February 6, 1984

ENG-C 44544  
Sheet 4 of 10  
Safeguards and Security Upgrades Phase 1  
Structure Hardening Monitoring Station  
Architecture: Plans, Elevations & Details  
August 6, 1985



TA-41-6 Passageway, Connecting Building TA-41-4 (on left)  
to Building TA-41-1, South Elevation



TA-41-6 Passageway, Connecting Building TA-41-1 (on right)  
to building TA-41-4, South Elevation

**OUTLINE SPECIFICATIONS**

1. GENERAL: The contractor shall provide all materials, labor, and equipment necessary for the construction of the building in accordance with the specifications and drawings. The contractor shall be responsible for obtaining all necessary permits and licenses.

2. MATERIALS: All materials shall be of the highest quality and shall conform to the specifications of the American Institute of Steel Construction, Inc. (AISC) and the American Concrete Institute (ACI). All materials shall be tested and certified by an independent testing agency.

3. CONSTRUCTION: The contractor shall construct the building in accordance with the drawings and specifications. The contractor shall be responsible for the safety of the construction site and shall provide all necessary safety measures.

4. SCHEDULE: The contractor shall complete the construction of the building within the schedule of time specified in the contract documents.

5. PAYMENT: The contractor shall be paid for the work performed in accordance with the schedule of payments specified in the contract documents.

6. WARRANTY: The contractor shall warrant the workmanship and materials of the building for a period of one year from the date of completion.

7. FORCE MAJEURE: In the event of a force majeure event, the contractor shall be relieved of its obligations under the contract.

8. ASSIGNMENT: The contractor shall not assign its obligations under the contract without the written consent of the owner.

9. ENTIRE AGREEMENT: This contract document shall constitute the entire agreement between the parties.

10. GOVERNING LAW: This contract shall be governed by the laws of the State of Illinois.

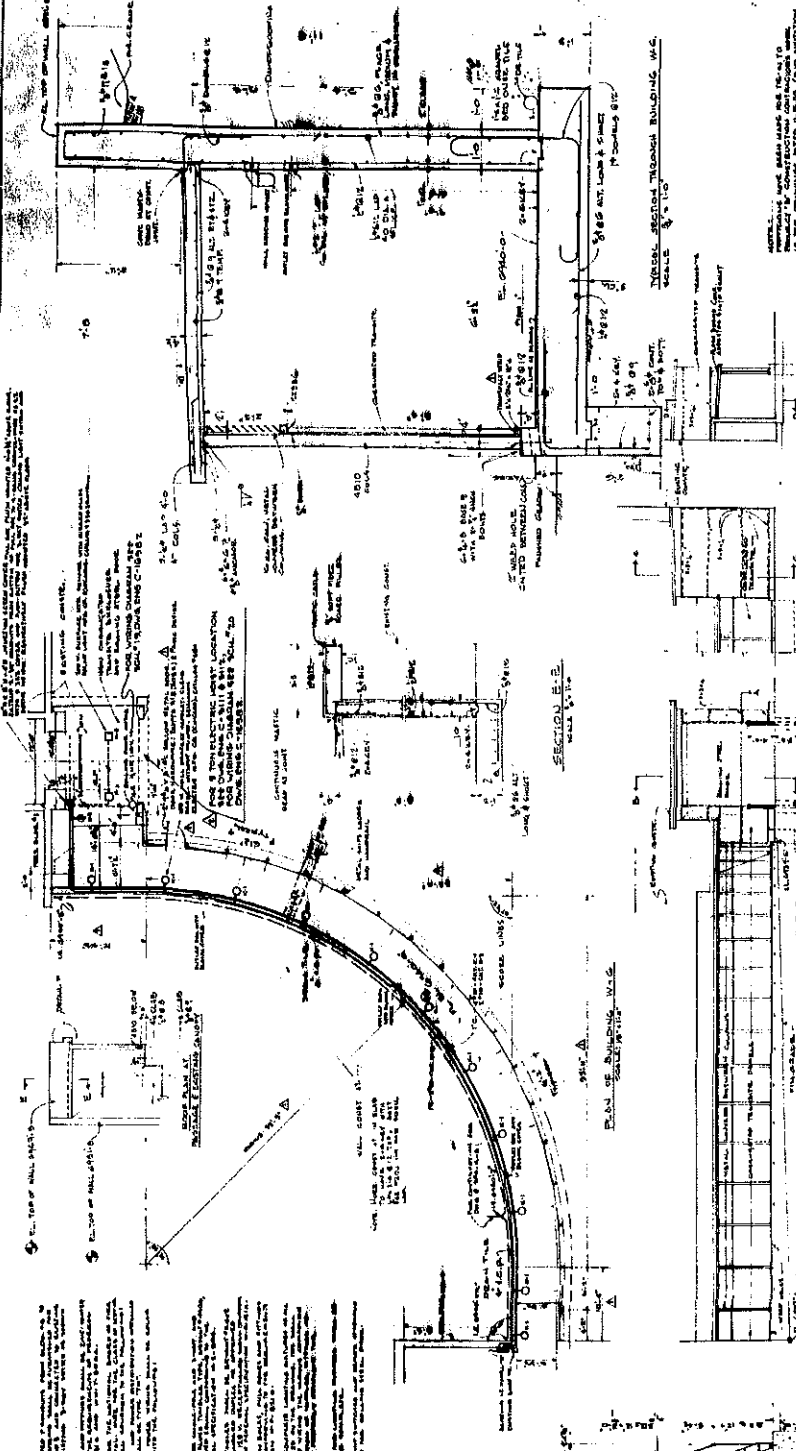

THIS IS AN OFFICIAL DOCUMENT OF THE UNITED STATES. IT MAY NOT BE REPRODUCED, COPIED, OR USED FOR OTHER THAN OFFICIAL PURPOSES WITHOUT THE WRITTEN CONSENT OF THE UNITED STATES ATOMIC ENERGY COMMISSION. THIS DOCUMENT IS SUBJECT TO THE LAWS OF THE UNITED STATES.

U.S. ATOMIC ENERGY COMMISSION LOS ALAMOS, NEW MEXICO	PROJECT # 11-1001	DATE 11-10-42	SCALE 1/4" = 1'-0"
PLANS, ELEVATIONS & DETAILS	PROJECT # 11-1001	DATE 11-10-42	SCALE 1/4" = 1'-0"
U.S. ATOMIC ENERGY COMMISSION LOS ALAMOS, NEW MEXICO	PROJECT # 11-1001	DATE 11-10-42	SCALE 1/4" = 1'-0"
PLANS, ELEVATIONS & DETAILS	PROJECT # 11-1001	DATE 11-10-42	SCALE 1/4" = 1'-0"
U.S. ATOMIC ENERGY COMMISSION LOS ALAMOS, NEW MEXICO	PROJECT # 11-1001	DATE 11-10-42	SCALE 1/4" = 1'-0"
PLANS, ELEVATIONS & DETAILS	PROJECT # 11-1001	DATE 11-10-42	SCALE 1/4" = 1'-0"

**RECORD DRAWINGS**  
THIS DRAWING REPRESENTS THE CONSTRUCTION AS BUILT  
CONTRACT NO. AT-1001-42  
DRAWN BY: [Signature]  
CHECKED BY: [Signature]  
APPROVED BY: [Signature]

SECTION A.A.  
SECTION B.B.  
SECTION C.C.  
SECTION D.D.  
SECTION E.E.  
SECTION F.F.  
SECTION G.G.  
SECTION H.H.  
SECTION I.I.  
SECTION J.J.  
SECTION K.K.  
SECTION L.L.  
SECTION M.M.  
SECTION N.N.  
SECTION O.O.  
SECTION P.P.  
SECTION Q.Q.  
SECTION R.R.  
SECTION S.S.  
SECTION T.T.  
SECTION U.U.  
SECTION V.V.  
SECTION W.W.  
SECTION X.X.  
SECTION Y.Y.  
SECTION Z.Z.

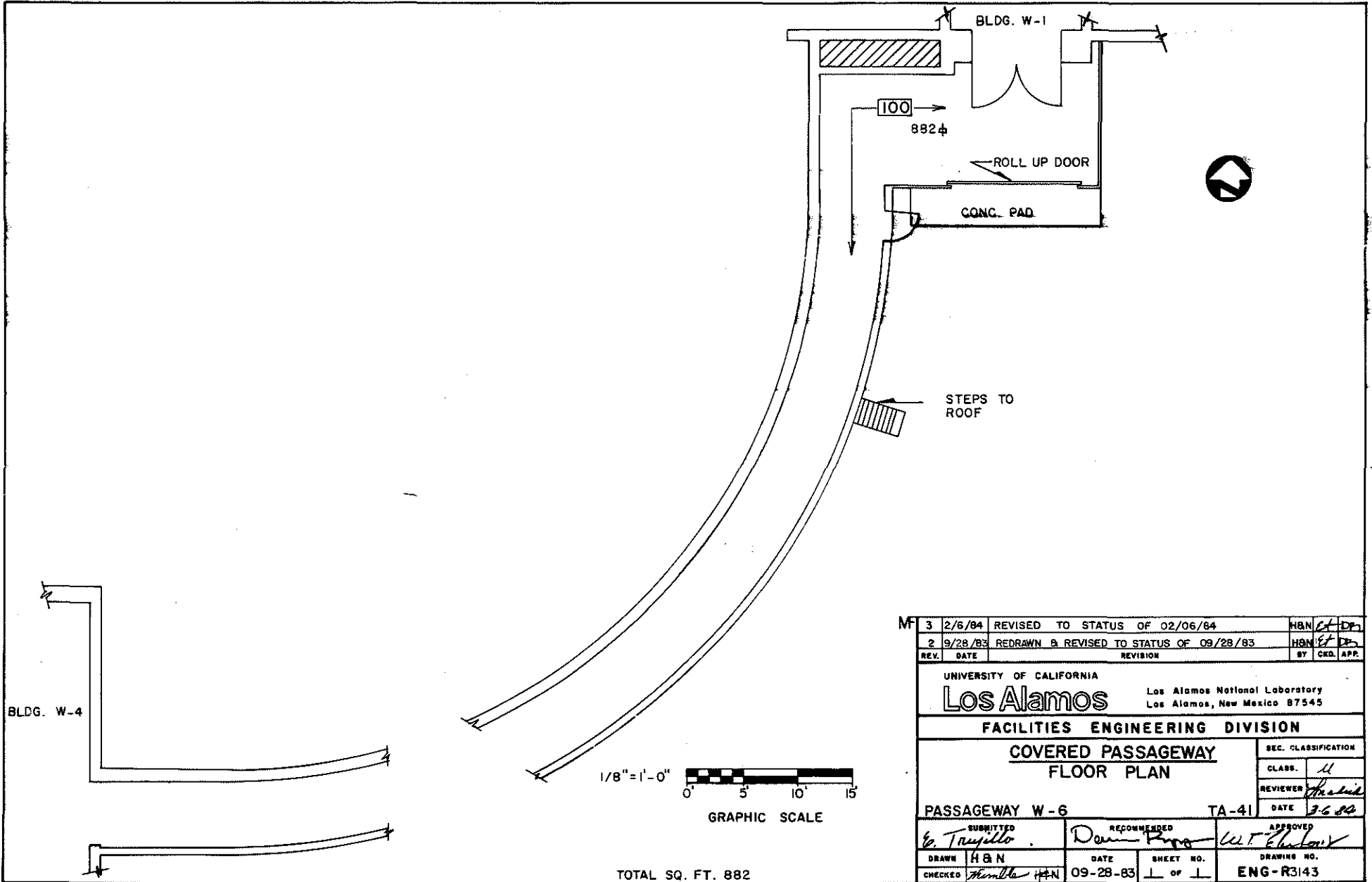

REV.	DATE	REVISION	BY	CHK.	APP.
3	2/6/84	REVISED TO STATUS OF 02/06/84	HBN	et	DP
2	9/28/83	REDRAWN & REVISED TO STATUS OF 09/28/83	HBN	et	DP
UNIVERSITY OF CALIFORNIA <b>Los Alamos</b> Los Alamos National Laboratory Los Alamos, New Mexico 87545					
FACILITIES ENGINEERING DIVISION					
COVERED PASSAGEWAY FLOOR PLAN					
PASSAGEWAY W-6				TA-41	
SUBMITTED <i>to Tausello</i>		RECOMMENDED <i>Don King</i>		APPROVED <i>W.T. Kinslow</i>	
DRAWN HBN		DATE 09-28-83		SHEET NO. 1 OF 1	
CHECKED <i>Humble HBN</i>		DRAWING NO. ENG-R3143			

TOTAL SQ. FT. 882

REC'D..... LOGGED..... TO VAULT *3/6/84*



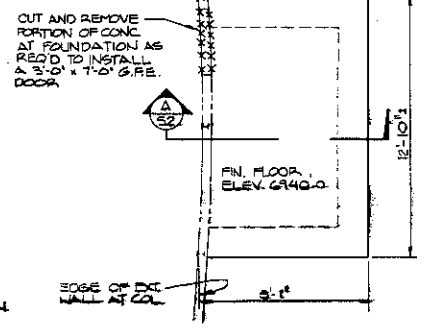
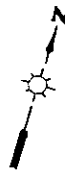

FOUNDATION PLAN  
SCALE 3/8"=1'-0"

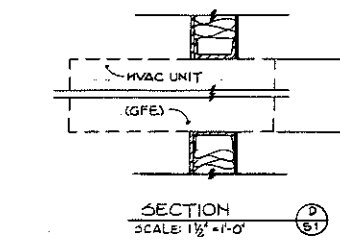

SECTION  
SCALE 1 1/2"=1'-0"

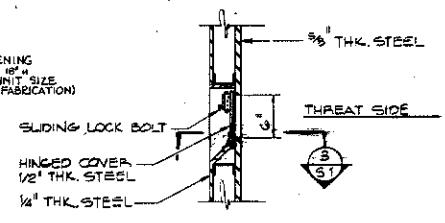

DETAIL  
SCALE 1 1/2"=1'-0"

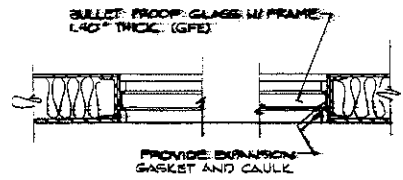

DETAIL  
SCALE 1 1/2"=1'-0"

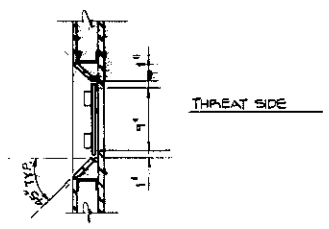

DETAIL  
SCALE 1 1/2"=1'-0"

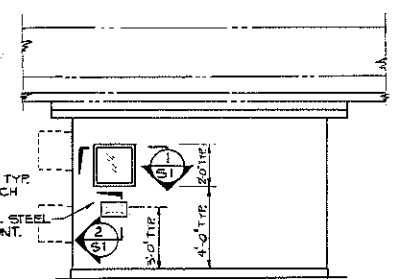

ELEVATION  
SCALE 3/8"=1'-0"

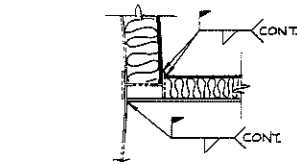

DETAIL  
SCALE 1 1/2"=1'-0"

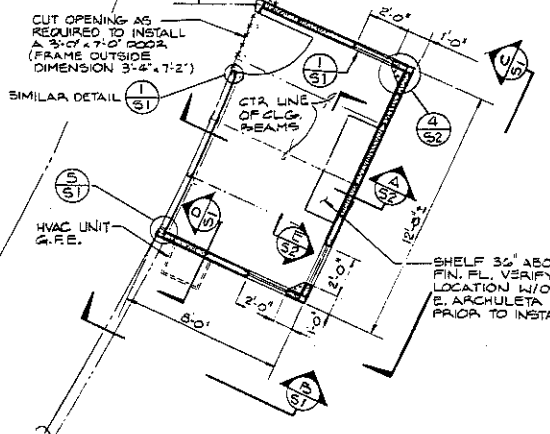

FLOOR PLAN  
SCALE 3/8"=1'-0"

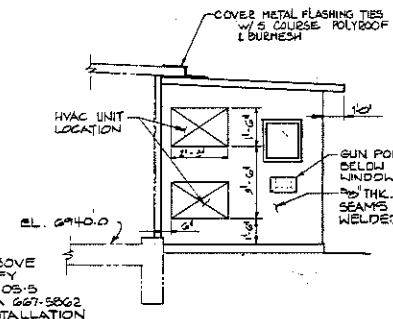

ELEVATION  
SCALE 3/8"=1'-0"

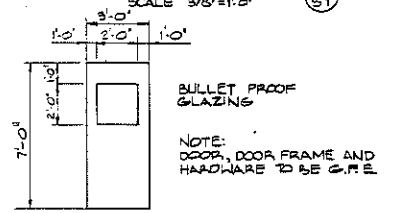

HARDENED DOOR,  
DOOR ELEVATION

NO.	DATE	CLASS. RECD.	REVISED	BY	CHKD.	DATE	BY	CHKD.	DATE	
<b>FACILITIES ENGINEERING DIVISION</b>										
SAFEGUARDS AND SECURITY UPGRADES PHASE I STRUCTURE HARDENING MONITORING STATION							DRAWN	K. S. Smith		
ARCH: PLANS ELEVATIONS & DETAILS							DESIGNED	E. S. Smith		
BLDG. W-6							CHECKED	M. S. Smith		
SUBMITTED: Michael Reynolds							RELEASED	R. S. Smith		
RECOMMENDED: Bruce Ferrer							DATE	8-6-85		
APPROVED: [Signature]							SHEET 4 OF 10			
Los Alamos National Laboratory Los Alamos, New Mexico 87545							SI			
CLASSIFICATION: 7							REVIEWED	Bruce Ferrer		
REQUESTING OFFICE: 8067-41							DRAWING NO. ENG-C 44544			
REQUISITION NO.: 05-1							DATE: 7-31-85			
PHASE B							REV.			

LANL TA- Building # 41-0016

Camera 984242

Frame #s DCP\_1076 through DCP\_1079

Surveyor(s) J.Ronquillo/K.Towery

Date 03/05/2002

Los Alamos National Laboratory CRMT  
Historic Building Survey Form

Building Name Guard Station #207 UTMs easting 382759 northing 3970831 zone 13

Legal Description: Map Guaje Mountain Quad, 1984 tnsr 19N range 6E sec 15

Current Use/ Function Unoccupied Original Use/ Function Guard Station

Date (estimated) 1950 Date (actual) 1952 Property Type Security

Type of Construction

Pre-Fabricated Metal  Steel Frame  Wood Frame  CMU  Reinforced Concrete

Other Type of Construction Unpainted concrete walls. # of Stories 1

Foundation Reinforced concrete.

Exterior CMU-Exterior  Reinforced Concrete-Exterior  Steel (galvanized)  Steel (corrugated)   
Wood Siding  Asbestos Shingles-Exterior  In-Fill Panels  Other-Exterior

Exterior Treatment (painted, stuccoed, etc) Unpainted concrete with 1 personnel door located on the south side. There is a 3 foot concrete overhang around the perimeter of the building.

Exterior Features (docks, speakers, lights, signs, etc) Concrete overhang.

Addition CMU-Addition  Reinforced Concrete-Addition  Steel (galvanized)- Addition  Wood   
Steel (corrugated)-Addition  Asbestos Shingles-Addition  Other- Addition None

Exterior Treatment-Addition

Exterior Features-Addition

Roof Form Slanted/Shed  Gable  Other Roof Type Flat with slight pitch.

Degree of Pitch/ Slope Slight

Roof Materials Corrugated Metal  Rolled Asphalt  Asbestos Shingles  4-Ply Built Up   
Other Roof Materials

Window Type Casement  Single Hung Sash  Double Hung Sash  Fixed Window   
Other Window Type Steel Sash Awning

# of Each Window Type/ Comments

Glass Type Clear  Wire Glass  Opaque  Painted Glass  Glass Block

Light Pattern One window is 3 over 2 and three windows are 3 over 4.

**Door Type**

Personnel Door Types

Exterior

Fire Door  Single  Double  Roll-up  Sliding   
 Hollow Metal  Solid Wood  1/2 Glazed  Paneled   
 Louvered  Painted

Interior

Fire Door  Single  Double  Roll-up  Sliding   
 Hollow Metal  Solid Wood  1/2 Glazed  Paneled   
 Louvered  Painted

Equipment Door Types

Exterior

Fire Door  Single  Double  Roll-up  Sliding   
 Hollow Metal  Solid Wood  1/2 Glazed  Paneled   
 Louvered  Painted

Interior

Fire Door  Single  Double  Roll-up  Sliding   
 Hollow Metal  Solid Metal  1/2 Glazed  Paneled   
 Louvered  Painted

# of Each Door Type/Comments:

**Interior Wall**

Gypsum Board  Reinforced Concrete- Interior

CMU- Interior  Plywood  Other- Interior

In-Wall Electrical Wiring  On-Wall Electrical Wiring

**Ceiling** Drop Ceiling

Interior Comments (Equipment, etc)

**Degree of Remodeling**

**Condition** Excellent  Good  Fair  Deteriorating  Contaminated  Burned

**Associated Building**

If yes, list building names and #s:

**Integrity**

**Significance**

**Eligible Under Criterion** A  B  C  D  Not Eligible

**DOE Themes**

Nuclear Weapon Components and Assembly  Nuclear Weapon Design and Testing  Nuclear Propulsion

Peaceful Uses: Plowshare, Nuclear Medicine, Nuclear Energy, Nuclear Science  Energy and Environment: Research Design Projects

**LANL Themes**

Weapons Research and Design, Testing, and Stockpile Support  Super Computing

Reactor Technology  Biomedical/Health Physics  Strategic and Supporting Research

Environment/Waste Management  Administration and Social History  Architectural History

**Recommendations/ Additional Comments**

**Architectural Features (elevations)**

Typical guard station architectural style of unpainted concrete exterior exhibiting simple design lines; "form follows function".

Total sq ft 87 Gross

Architect/ Builder

Contractor: Claremont Construction

**Alterations**

**List of Drawings (Cntrl + Enter for para break)**

ENG-C 15110  
Sheet 2 of 2  
W-Site, TA-41  
W-16 Guard Station  
Guardhouse  
Plan and Details  
November 13, 1951

ENG-R 3144  
TA-41, Building 16  
Guard House  
Floor Plan  
March 6, 1984



TA-41-16 Guard Station, South Elevation

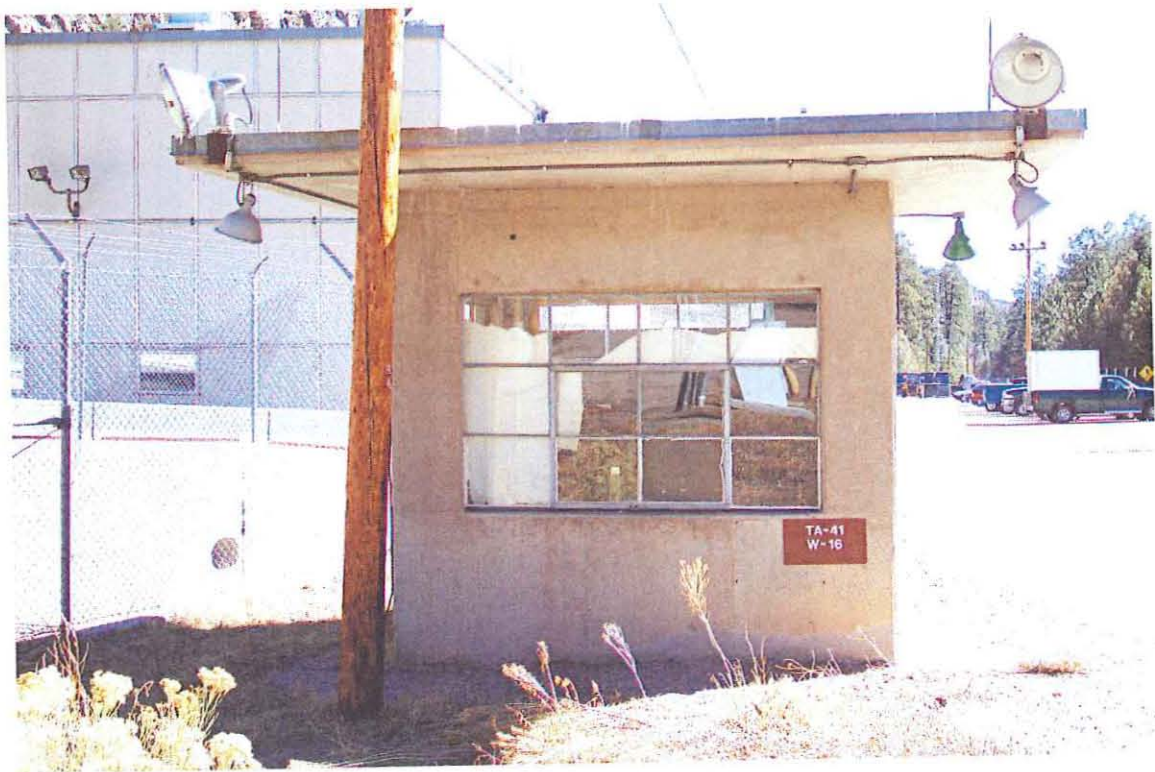

TA-41-16 Guard Station, West Elevation

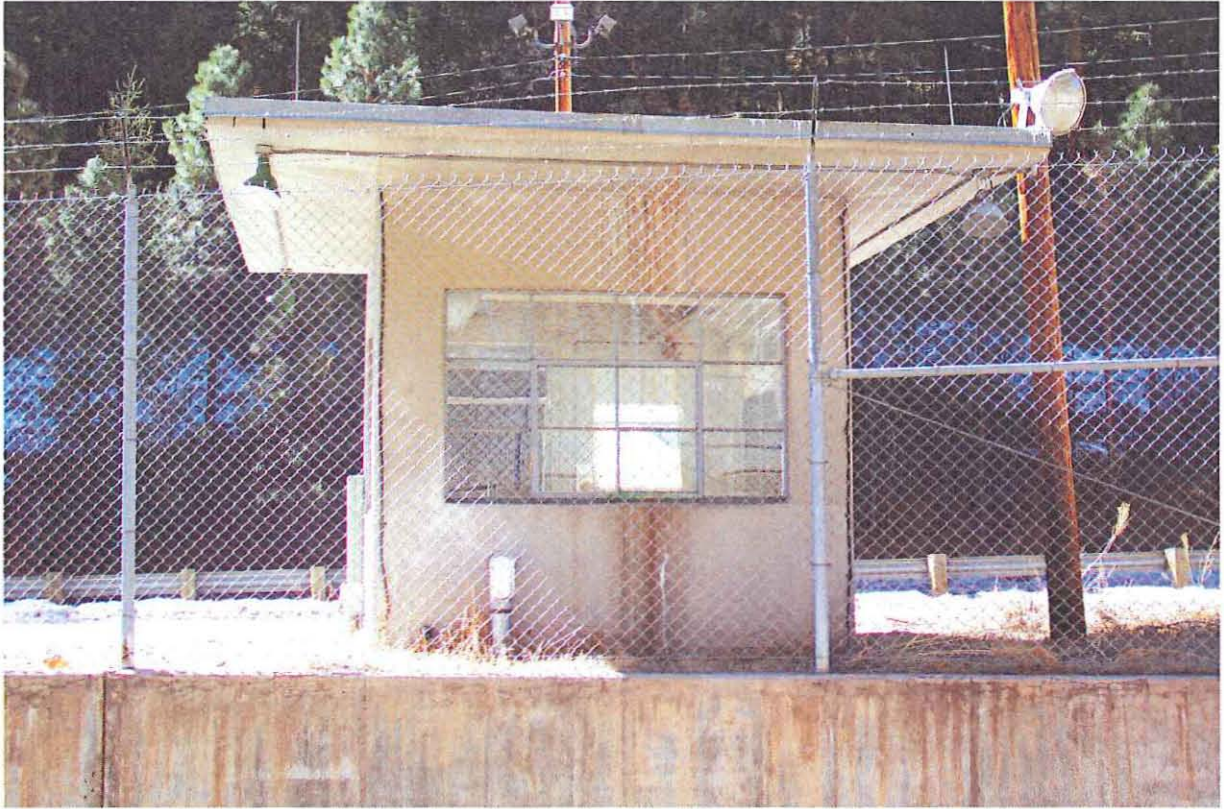

TA-41-16 Guard Station, North Elevation



TA-41-16 Guard Station, East Elevation



TA-41-16 Guard Station, North Elevation



TA-41-16 Guard Station, East Elevation





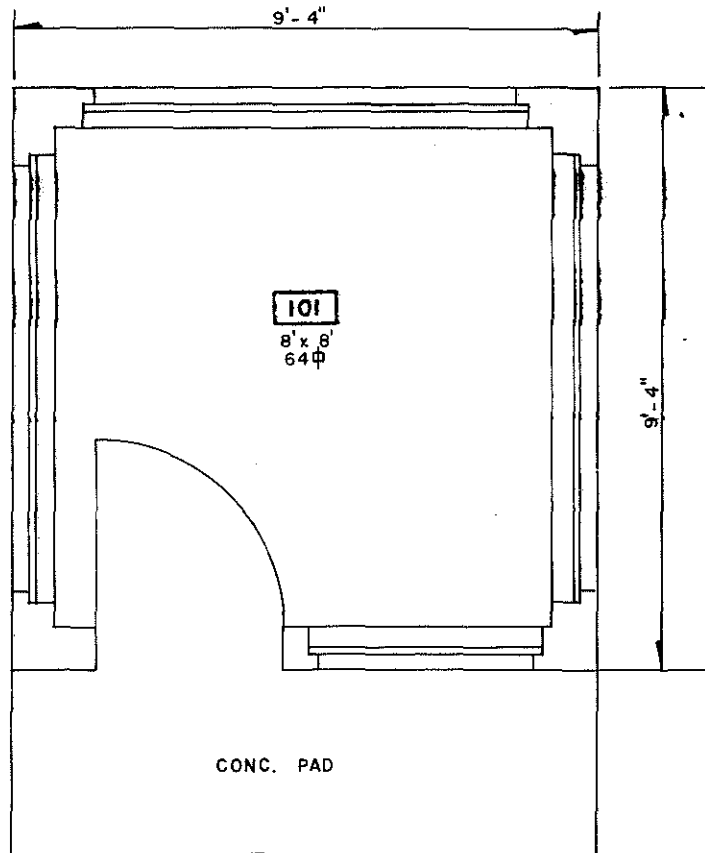

TOTAL  $\frac{\text{ft}^2}{64}$

REV.	DATE	REVISION	BY	CHKD.	APPD.
2	2/6/84	REVISED TO STATUS OF 2/6/84	HBN	ET	DP
1	9/28/83	REDRAWN & REVISED TO STATUS OF 09/28/83	HBN	ET	DP

UNIVERSITY OF CALIFORNIA		Los Alamos National Laboratory Los Alamos, New Mexico 87545	
<b>Los Alamos</b>			
FACILITIES ENGINEERING DIVISION			
<b>GUARD HOUSE FLOOR PLAN</b>		SEC. CLASSIFICATION	
BLDG. W-16		TA-41	
SUBMITTED <i>E. Trujillo</i>		RECOMMENDED <i>Dawn Perry</i>	
DRAWN HBN		DATE 9-28-83	
CHECKED <i>Humble</i>		SHEET NO. 1 OF 1	
APPROVED <i>W.T. Buford</i>		DRAWING NO. ENG-R3144	

REC'D ..... LOGGED ..... TO VAULT *3/2/84*

LANL TA- Building # 41-0047

Camera 984242

Frame #s DCP\_0770 and DCP\_0771

Surveyor(s) K.Towery/J.Ronquillo

Date 01/17/2002

Los Alamos National Laboratory CRMT Historic Building Survey Form

Building Name Exhaust Stack UTMs easting 382877 northing 3970862 zone 13

Legal Description: Map Guaje Mountain Quad 1984 tnspl 19N range 6E sec 15

Current Use/ Function Exhaust Stack Original Use/ Function Exhaust Stack

Date (estimated) Date (actual) Property Type Support

Type of Construction

Pre-Fabricated Metal Steel Frame Wood Frame CMU Reinforced Concrete

Other Type of Construction 12" steel stack approx. 60' high adjacent to the west side of TA-41-4. # of Stories

Foundation Reinforced Concrete.

Exterior CMU-Exterior Reinforced Concrete-Exterior Steel (galvanized) Steel (corrugated) Wood Siding Asbestos Shingles-Exterior In-Fill Panels Other-Exterior

Exterior Treatment (painted, stuccoed, etc) Painted.

Exterior Features (docks, speakers, lights, signs, etc)

Addition CMU-Addition Reinforced Concrete-Addition Steel (galvanized)- Addition Wood Steel (corrugated)-Addition Asbestos Shingles-Addition Other- Addition

Exterior Treatment-Addition

Exterior Features-Addition

Roof Form Slanted/Shed Gable Other Roof Type

Degree of Pitch/ Slope

Roof Materials Corrugated Metal Rolled Asphalt Asbestos Shingles 4-Ply Built Up Other Roof Materials

Window Type Casement Single Hung Sash Double Hung Sash Fixed Window Other Window Type

# of Each Window Type/ Comments

Glass Type Clear Wire Glass Opaque Painted Glass Glass Block

Light Pattern

Door Type Personnel Door Types Exterior Fire Door Single Double Roll-up Sliding

		Hollow Metal <input type="checkbox"/>	Solid Wood <input type="checkbox"/>	1/2 Glazed <input type="checkbox"/>	Paneled <input type="checkbox"/>	
		Louvered <input type="checkbox"/>	Painted <input type="checkbox"/>			
	Interior	Fire Door <input type="checkbox"/>	Single <input type="checkbox"/>	Double <input type="checkbox"/>	Roll-up <input type="checkbox"/>	Sliding <input type="checkbox"/>
		Hollow Metal <input type="checkbox"/>	Solid Wood <input type="checkbox"/>	1/2 Glazed <input type="checkbox"/>	Paneled <input type="checkbox"/>	
		Louvered <input type="checkbox"/>	Painted <input type="checkbox"/>			
Equipment Door Types	Exterior	Fire Door <input type="checkbox"/>	Single <input type="checkbox"/>	Double <input type="checkbox"/>	Roll-up <input type="checkbox"/>	Sliding <input type="checkbox"/>
		Hollow Metal <input type="checkbox"/>	Solid Wood <input type="checkbox"/>	1/2 Glazed <input type="checkbox"/>	Paneled <input type="checkbox"/>	
		Louvered <input type="checkbox"/>	Painted <input type="checkbox"/>			
	Interior	Fire Door <input type="checkbox"/>	Single <input type="checkbox"/>	Double <input type="checkbox"/>	Roll-up <input type="checkbox"/>	Sliding <input type="checkbox"/>
		Hollow Metal <input type="checkbox"/>	Solid Metal <input type="checkbox"/>	1/2 Glazed <input type="checkbox"/>	Paneled <input type="checkbox"/>	
		Louvered <input type="checkbox"/>	Painted <input type="checkbox"/>			

# of Each Door Type/Comments:

**Interior Wall** Gypsum Board  Reinforced Concrete- Interior

CMU- Interior  Plywood  Other- Interior

In-Wall Electrical Wiring  On-Wall Electrical Wiring

**Ceiling** Drop Ceiling

Interior Comments (Equipment, etc)

**Degree of Remodeling**

**Condition** Excellent  Good  Fair  Deteriorating  Contaminated  Burned

**Associated Building**

If yes, list building names and #:

**Integrity**

**Significance**

**Eligible Under Criterion** A  B  C  D  Not Eligible

**DOE Themes**

Nuclear Weapon Components and Assembly  Nuclear Weapon Design and Testing  Nuclear Propulsion

Peaceful Uses: Plowshare, Nuclear Medicine, Nuclear Energy, Nuclear Science  Energy and Environment: Research Design Projects

**LANL Themes**

Weapons Research and Design, Testing, and Stockpile Support  Super Computing

Reactor Technology  Biomedical/Health Physics  Strategic and Supporting Research

Environment/Waste Management  Administration and Social History  Architectural History

**Recommendations/ Additional Comments**

**Architectural Features (elevations)**

**Total sq ft**

**Architect/ Builder**

**Alterations**

**List of Drawings (Cntrl + Enter for para break)**

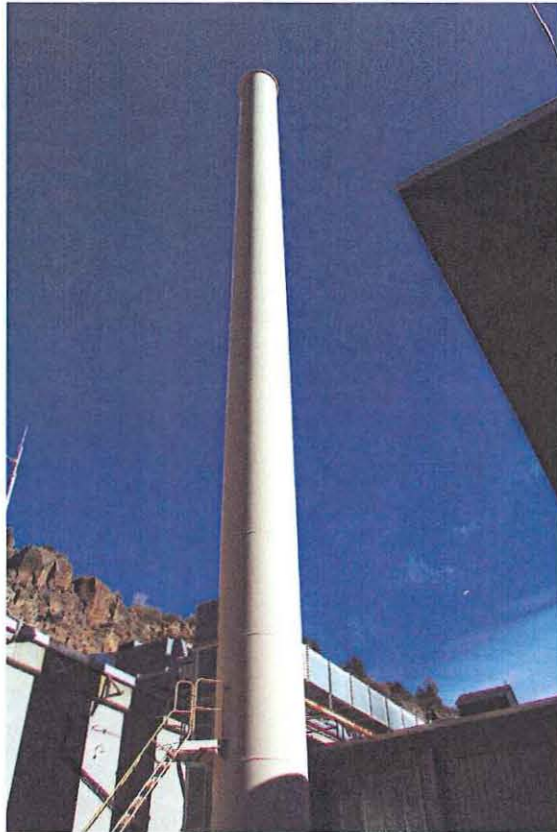

TA-41-47  
Exhaust Stack

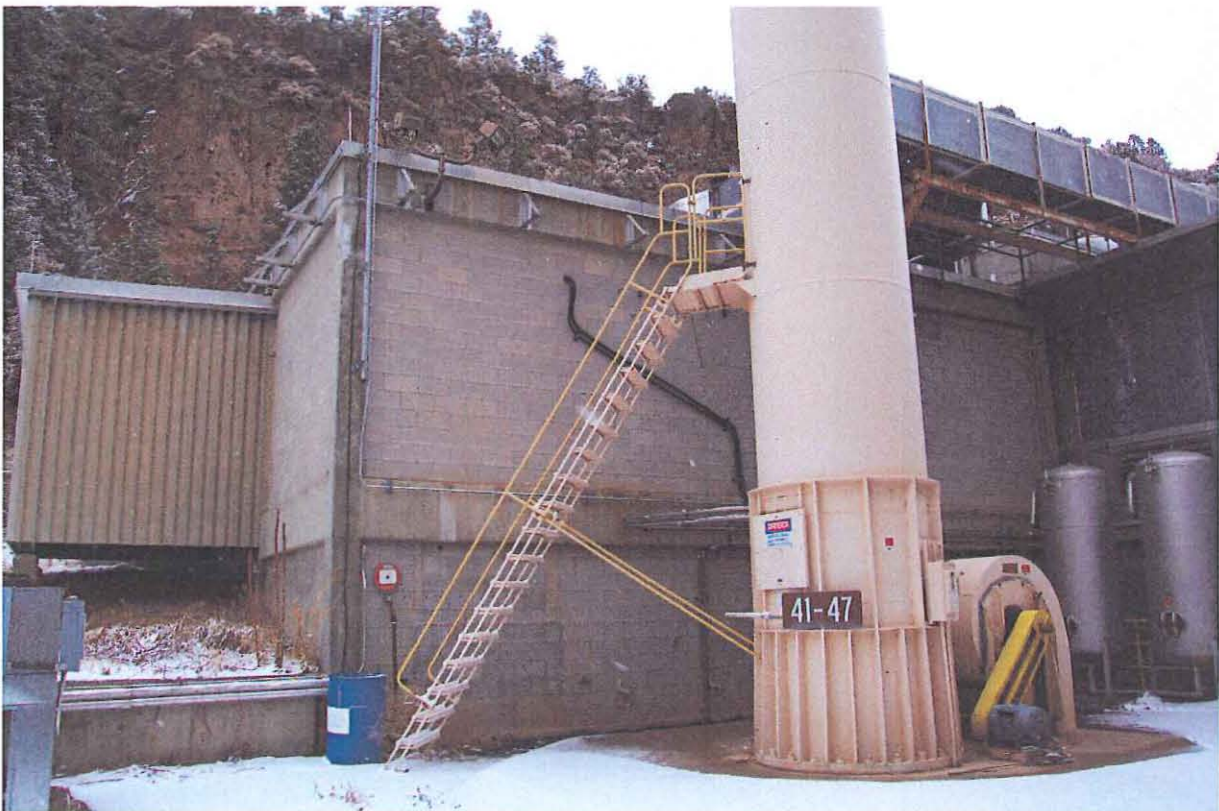

TA-41-47 Exhaust Stack and TA-41-4 South Elevation of North Wing

**Appendix B: Maps Showing Location of Eligible and  
Non-Eligible Properties and TA-41 Construction History**

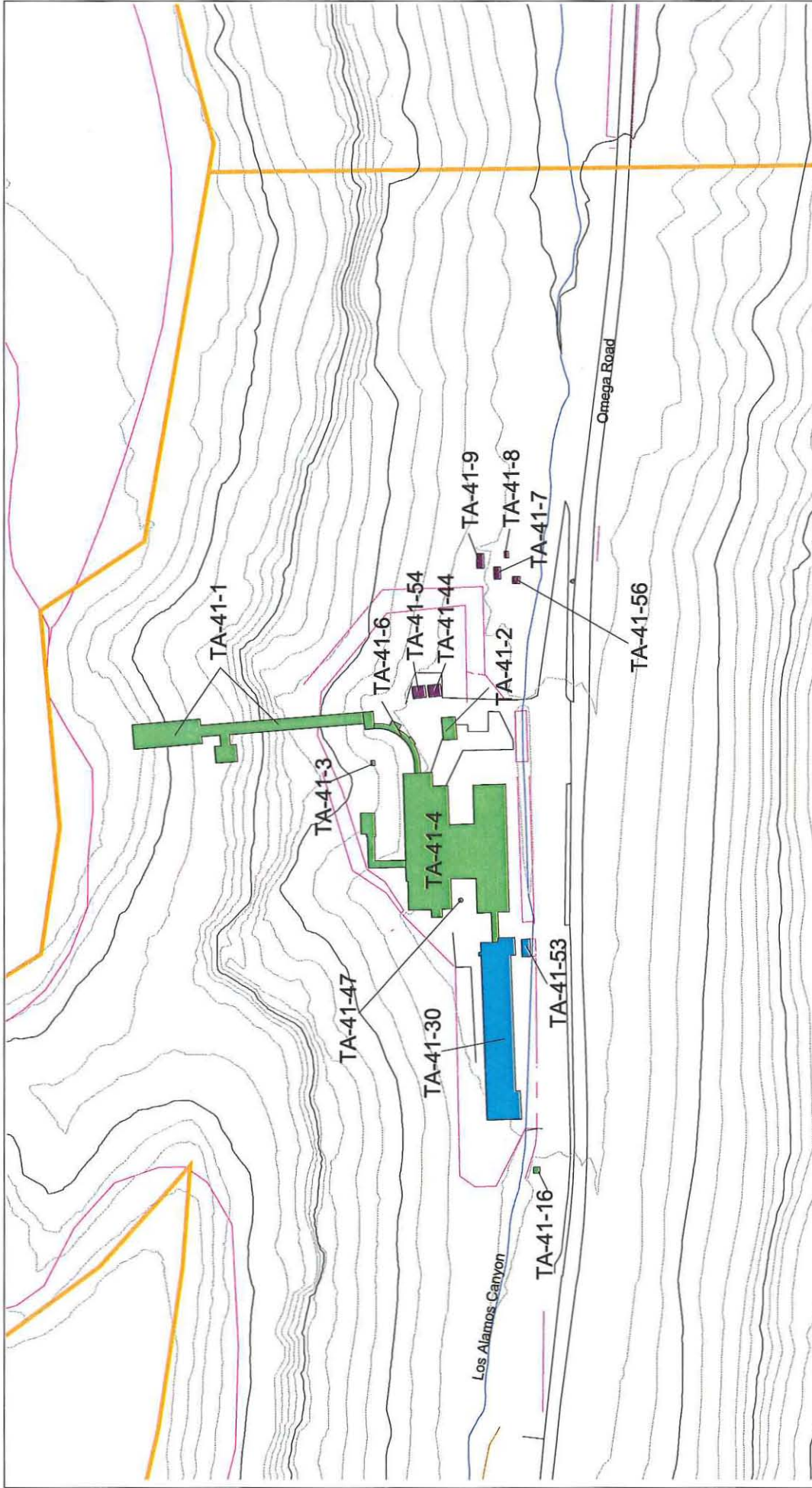

Guaje Mountain Quad

1:2500

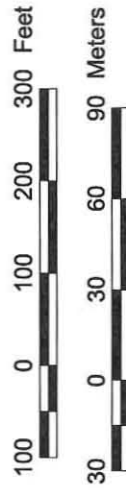

- Eligible Buildings/Structures
- Not Eligible Buildings/Structures
- Exempt Buildings/Structures
- 20 Foot Contours
- 100 Foot Contours
- Techarea
- Drainage
- Township, Section, Range
- USGS 7.5 Minute Quad
- Trails
- Roads
- Roaddirt
- Parkpave
- Parkdirt
- Fences



**TA-41**  
**Eligible and**  
**Not Eligible Buildings**  
**Shown prior to Demolition**

B-1

**Los Alamos**  
**National Laboratory**  
 Heritage Resources and  
 Environmental Policy Compliance Team  
 RRES-ECO (Ecology Group)

STRUCTURE NUMBER	DESIGNATION	REMARKS
TA-41-1	W-1	UNDERGROUND VAULT
TA-41-2	W-2	GUARD HOUSE (STATION 312)
TA-41-3	W-3	BLOWER HOUSE
TA-41-4	W-4	GUARD HOUSE (STATION 311)
TA-41-5	W-5	COVERED PASSAGEWAY
TA-41-6	W-6	INHOFF TANK & CHLORINE ROOM
TA-41-7	W-7	CONTACT TANK
TA-41-8	W-8	DRYING BED
TA-41-9	W-9	SUMP PIT
TA-41-10	W-10	SEWER TANK (SANITARY)
TA-41-11	W-11	RETAINING WALL
TA-41-12	W-12	RETAINING WALL
TA-41-13	W-13	RETAINING WALL
TA-41-14	W-14	BRIDGE
TA-41-15	W-15	BRIDGE
TA-41-16	W-16	BRIDGE
TA-41-17	W-17	BRIDGE
TA-41-18	W-18	MANHOLE (WATER PIP)
TA-41-19	W-19	MANHOLE (SANITARY SEWER)
TA-41-20	W-20	MANHOLE (SANITARY SEWER)
TA-41-21	W-21	MANHOLE (STORM SEWER)
TA-41-22	W-22	MANHOLE (STORM SEWER)
TA-41-23	W-23	MANHOLE (STORM SEWER)
TA-41-24	W-24	MANHOLE (STORM SEWER)
TA-41-25	W-25	MANHOLE (STORM SEWER)
TA-41-26	W-26	MANHOLE (STORM SEWER)
TA-41-27	W-27	MANHOLE (STORM SEWER)
TA-41-28	W-28	MANHOLE (STORM SEWER)
TA-41-29	W-29	RESERVE
TA-41-30	W-30	ENGINEERING LABS BLDG. (PROPOSED)

DOES NOT CONTAIN  
OFFICIAL USE ONLY  
INFORMATION  
Name/Org: Jill Heitele/S-7 Date: 8/30/04

OBSCURE DEAD STORAGE

UNIVERSITY OF CALIFORNIA - LOS ANGELES

LOG ALABOS SCIENTIFIC LABORATORY  
ENGINEERING DEPARTMENT

STRUCTURE LOCATION PLAN  
TA-41  
W-SITE

DATE: 7/23/57  
DRAWN BY: J. HEITEL  
CHECKED BY: J. HEITEL  
SCALE: AS SHOWN

ENGINEER: J. HEITEL  
LICENSE NO.: 164

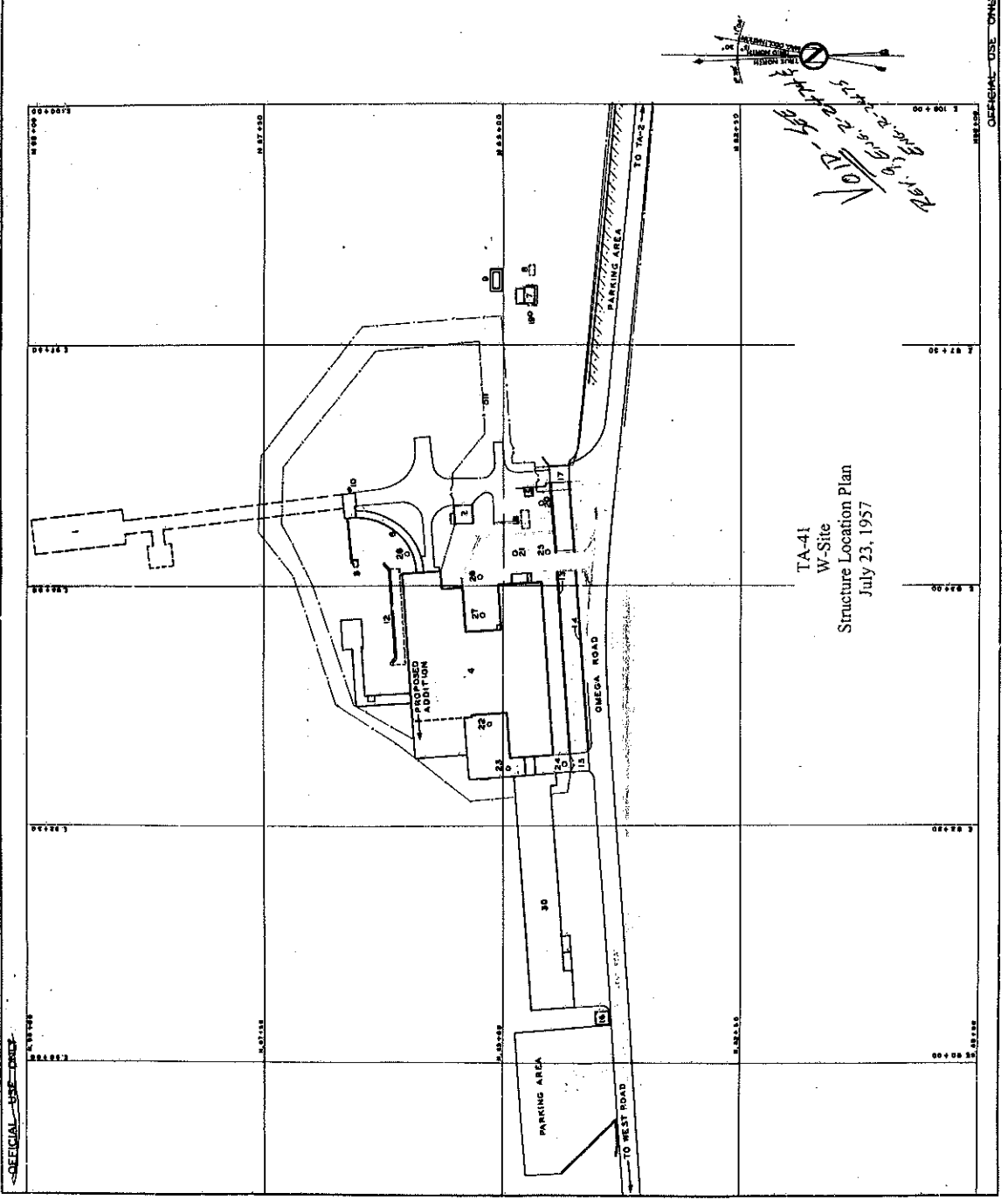

TA-41  
W-Site  
Structure Location Plan  
July 23, 1957

OFFICIAL USE ONLY



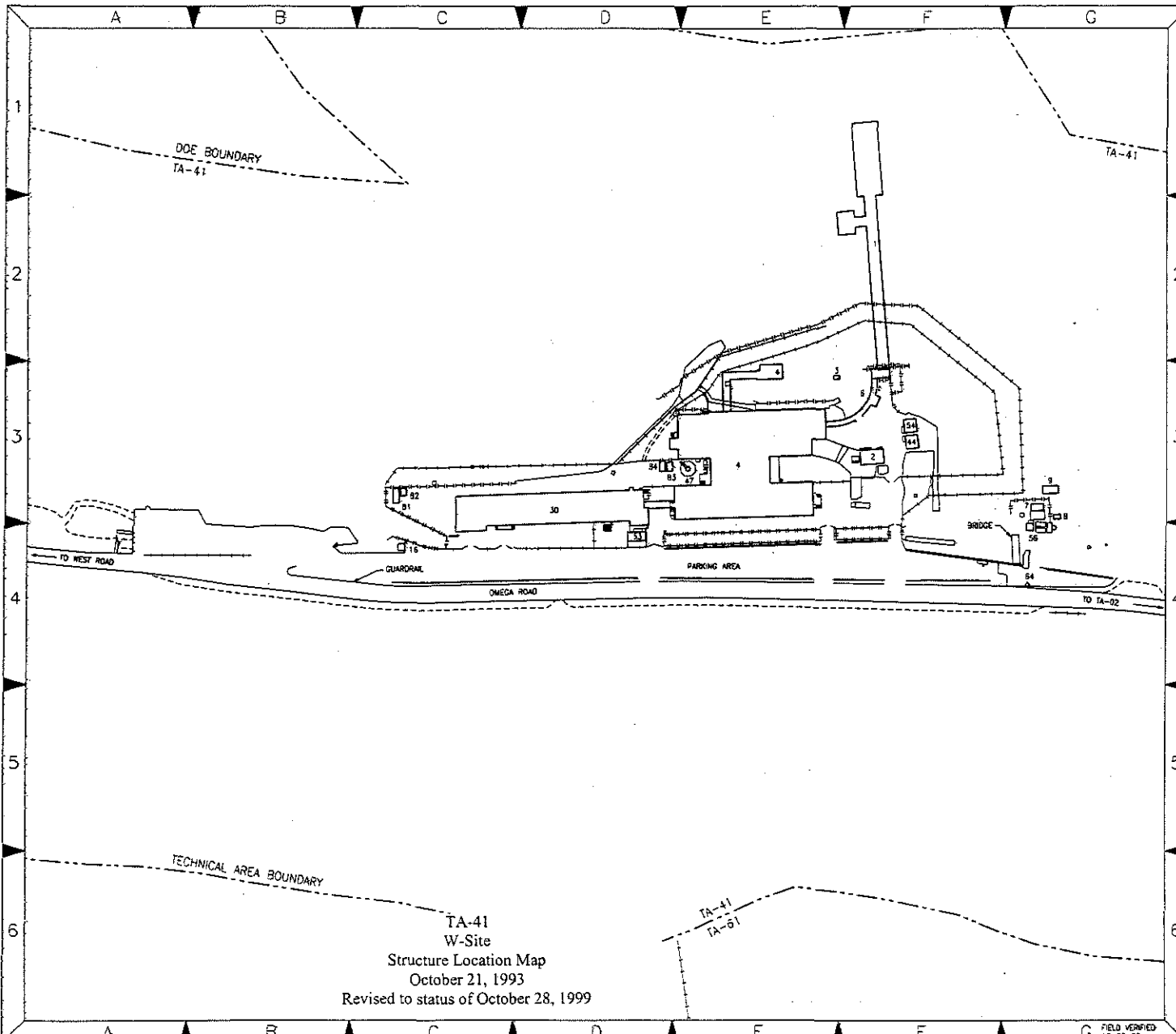

TA-41  
W-Site  
Structure Location Map  
October 21, 1993  
Revised to status of October 28, 1999

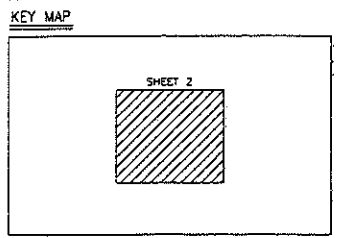

STRUCTURE LOCATION INDEX

STRUCTURE TA-#	DESIGNATION	STRUCTURE NOMENCLATURE	STRUCTURE LOCATOR SHEET NO.	MAP KEY
41-1	W-1	UNDERGROUND VAULT	2	F-2
41-2	W-2	GUARD STATION #318	2	F-3
41-3	W-3	BLOWER HOUSE	2	C-3
41-4	W-4	LABORATORY BUILDING	2	E-3
41-6	W-6	CONCRETE PASSAGEWAY	2	F-3
41-7	41-7	WASHOFF TANK & CHLORINE ROOM	2	D-3
41-8	41-8	CONTACT TANK	2	D-3
41-9	41-9	DRYING BED	2	D-3
41-16	41-16	GUARD STATION #207	2	C-4
41-30	W-30	OFFICE BUILDING	2	D-3
41-44	W-44	STORAGE BUILDING	2	F-3
41-47	41-47	EXHAUST STACK	2	E-3
41-53	W-53	GUARD STATION #311	2	D-4
41-54	W-54	STORAGE BUILDING	2	P-3
41-56	41-56	LIFT STATION	2	C-4
41-64	41-64	METEOROLOGICAL TOWER	2	C-4
41-81	41-81	TRANSPORTER	2	C-3
41-82	41-82	TRANSPORTER	2	C-3
41-83	41-83	COOLER	2	D-3
41-94	41-94	LIQUID NITROGEN TANK	2	D-3

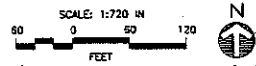

NO	DATE	CLASS REV	DESCRIPTION	DRW	CHKD	SUB	APP
3	10-28-99		REVISED TO STATUS OF 10-28-99				
<b>Johnson Controls</b> Northern New Mexico							
AS-BUILT STRUCTURE LOCATION MAPS				DRWN	L. WORK		
TA-41				VERIFIED	L. WORK		
W-SITE				CHECKED	A. SALAZAR		
				DATE	10-21-93		
SUBMITTED				APPROVED FOR RELEASE			
HAROLD SALAZAR				LARRY BAYS			
Los Alamos				Los Alamos National Laboratory Los Alamos, New Mexico 87545			
CLASSIFICATION				REVISOR	HAROLD SALAZAR	DATE	7-2-99
PROJECT 0				DRAWING NO			
11952				AB32			
PROJECT 0				REV			
10-28-99				3			

**Appendix C: Interview Information**

Oral Histories

Larson, R.

2003 Interview with John Ronquillo and Ellen McGehee. Recording of August 8, 2003 interview with Richard Larson on file at RRES-ECO, Los Alamos National Laboratory, Los Alamos, New Mexico.

Plassmann, E.

2003 Interview with John Ronquillo and Ellen McGehee. Recording of August 11, 2003 interview with Elizabeth "Beth" Plassmann on file at RRES-ECO, Los Alamos National Laboratory, Los Alamos, New Mexico.

**Appendix D: Listing of Drawings on File at LANL for  
TA-41**

**REPORT FOR: DRAWINGS**

TA	BLDG	PREFIX	DRAWNUM	PAGE	REV	DSHEET	LOG_DATE	DOC_DATE	PROJID	DISC	TITLE
41	1	AB	111	1	0		16-JUN-93	31-MAR-93	7556	A	AS-BUILT RECORD FLOOR PLAN + UNDERGROUND VAULT, FIRST FLOOR PLAN
41	1	C	249	1	3		20-DEC-48	20-DEC-48	0	A	STEEL SHELVING UNIT, BLDG. W-1
41	1	C	735	1	1		23-APR-50	23-APR-50	496	M	REPAIRS TO INNER VAULT DOOR HINGES W-SITE
41	1	C	1577	3	1		12-MAY-53	04-DEC-50	145	S	L A PROJECT EXPLOSIVE STORAGE, W-SITE. PLANS & REINFORCING, PORTAL, BLDG W-1
41	1	C	1578	4	1		12-MAY-53	01-FEB-51	145	S	L A PROJECT EXPLOSIVE STORAGE, W-SITE. PLANS & REINFORCINS, PORTAL & AIR INTAKE
41	1	C	1579	5	1		12-MAY-53	04-DEC-50	145	A	L A PROJECT EXPLOSIVE STORAGE, W-SITE. DETAILS, PORTAL ENTRANCE DOOR, BLDG. W-1
41	1	C	1580	6	1		12-MAY-53	04-DEC-50	145	A	L A PROJECT EXPLOSIVE STORAGE, W-SITE. DETAILS, ENTRANCE DOOR, UNIT "A", BLDG.
41	1	C	1581	7	1		12-MAY-53	04-DEC-50	145	A	L A PROJECT EXPLOSIVE STORAGE, S-SITE. PLANS & SECTIONS, UNIT "A", BLDG. W-1
41	1	C	1582	8	2		12-MAY-53	04-DEC-50	145	A	L A PROJECT EXPLOSIVE STORAGE, W-SITE. ELEVATIONS & SECTIONS, UNIT "A", BLDG. W
41	1	C	1583	9	1		12-MAY-53	04-DEC-50	145	S	L A PROJECT EXPLOSIVE STORAGE, W-SITE. REINFORCING DETS., MAIN CHAMBER, UNIT "A"
41	1	C	1584	10	1		12-MAY-53	06-DEC-50	145	S	L A PROJECT EXPLOSIVE STORAGE, W-SITE. REINFORCING DETS., VAULTS, UNIT "A", BLD
41	1	C	1585	11	1		12-MAY-53	04-DEC-50	145	S	L A PROJECT EXPLOSIVE STORAGE, W-SITE. REINFORCING DETAILS. FLOOR PLANS & PARTITION WALL, UNIT A
41	1	C	1586	12	3		12-MAY-53	17-FEB-51	145	A	L A PROJECT EXPLOSIVE STORAGE, W-SITE. PLANS & SECTION, UNIT "B", BLDG. W-1
41	1	C	1587	13	2		12-MAY-53	04-DEC-50	145	A	L A PROJECT EXPLOSIVE STORAGE, W-SITE. ELEVATIONS & SECTIONS, UNIT "B", BLDG. W
41	1	C	1588	14	2		12-MAY-53	04-DEC-50	145	A	L A PROJECT EXPLOSIVE STORAGE, W-SITE. PLANS & SECT., UNIT "C", BLDG. W-1
41	1	C	1589	14	1		12-MAY-53	04-DEC-51	145	A	L A PROJECT EXPLOSIVE STORAGE, W-SITE. SUPPORTED TUNNEL DETAILS, BLDG. W-1
											EXPLOSIVE STORAGE PROJECT, W-SITE. SUPPORTED TUNNEL

41	1	C	1590	14	1
41	1	C	1591	15	1
41	1	C	1596	20	1
41	1	C	1597	21	1
41	1	C	1598	22	1
41	1	C	1599	23	1
41	1	C	1600	24	2
41	1	C	1601	25	2
41	1	C	1602	26	1
41	1	C	1603	27	1
41	1	C	1604	28	2
41	1	C	1605	29	1
41	1	C	1606	30	2
41	1	C	1608	32	1
41	1	C	1609	33	1
41	1	C	1610	34	1
41	1	C	3112	2	0

12-MAY-53	04-DEC-50	145	A	DETS., W-1
12-MAY-53	04-DEC-50	145	S	EXPLOSIVE STORAGE PROJECT, W-SITE. REINFORCING DETAILS., UNIT "C", W-1
12-MAY-53	06-DEC-50	145	E	EXPLOSIVE STORAGE PROJECT, W-SITE. SITE PLAN, ELECT. WORK, W-1
12-MAY-53	06-DEC-50	145	E	EXPLOSIVE STORAGE PROJECT, W-SITE. GROUNDING PLAN. W-1
12-MAY-53	06-DEC-50	145	E	EXPLOSIVE STORAGE PROJECT, W-SITE. LIGHTING LAYOUT, UNIT "A", W-1
12-MAY-53	06-DEC-50	145	E	EXPLOSIVE STORAGE PROJECT, W-SITE. LIGHTING SECTIONS, W-1
12-MAY-53	06-DEC-50	145	E	EXPLOSIVE STORAGE PROJECT, W-SITE. LIGHTING & POWER LAYOUTS, UNITS "B" & "C", W
12-MAY-53	06-DEC-50	145	E	EXPLOSIVE STORAGE PROJECT, W-SITE. LIGHTING & POWER LAYOUT, SENTRY HOUSE, W-1
12-MAY-53	06-DEC-50	145	E	EXPLOSIVE STORAGE PROJECT, W-SITE. POWER SUPPLY AND FLOODLIGHTING INSTALLATION,
12-MAY-53	06-DEC-50	145	E	EXPLOSIVE STORAGE PROJECT, W-SITE. FLOODLIGHTING INSTALLATIONS, W-1, TRANSFORMER INSTALLATION, CONNECTION DIAGRAM
12-MAY-53	06-DEC-50	145	AC	EXPLOSIVE STORAGE PROJECT, W-SITE. VENTILATING & AIR CONDITIONING, LAYOUT UNITS "A", "B", "C
12-MAY-53	06-DEC-50	145	AC	EXPLOSIVE STORAGE PROJECT, W-SITE. VENTILATING & AIR CONDITIONING, LAYOUT UNITS "A", "B", "C
12-MAY-53	06-DEC-50	145	AC	EXPLOSIVE STORAGE PROJECT, W-SITE. VENTILATING & AIR CONDITIONING DETAILS., W-1
12-MAY-53	06-DEC-50	145	E	EXPLOSIVE STORAGE PROJ., W-SITE. SCHEMATIC DIAGRAM, POWER AND LIGHTING, BLDG. 1 AND 2
12-MAY-53	06-DEC-50	145	G	EXPLOSIVE STORAGE PROJECT, W-SITE. REINFORCING BILL OF MATERIAL
12-MAY-53	06-DEC-50	145	G	EXPLOSIVE STORAGE PROJECT, W-SITE. REINFORCING STEEL BILL OF MATERIAL
30-OCT-53	30-OCT-53	1525	E	ELECTRICAL HOIST INSTALLATION, ELECTRICAL PLAN & DETAILS, AREA 3

41	1	C	12026	1	0
41	1	C	12027	2	0
41	1	C	12028	3	0
41	1	C	12029	4	0
41	1	C	16980	1	0
41	1	C	16984	5	0
41	1	C	23660	1	0
41	1	C	25842	1	0
41	1	C	27378	1	0
41	1	C	27379	2	0
41	1	C	27847	1	0
41	1	C	27848	2	0
41	1	C	27849	3	0
41	1	C	31741	1	0
41	1	C	31742	2	0
41	1	C	31743	3	0
41	1	C	31744	4	0
41	1	C	31745	5	0
41	1	C	31746	6	0
41	1	C	36183	1	0
41	1	C	43554	8	0

13-JAN-56	11-JAN-56	1750	M	VENTILATION SYSTEM, MOD., BLDG. W-1, VENTILATING PLAN
13-JAN-56	11-JAN-56	1750	M	VENTILATING SYS. MODIFICATIONS, SECTIONS & DETAILS
13-JAN-56	11-JAN-56	1750	E	VENTILATION SYS. MODIFICATIONS, PLAN & MATERIALS
13-JAN-56	11-JAN-56	1750	E	VENT. SYS. MODIFICATIONS, WIRING DIA. & DETAILS
21-MAY-56		0	UN	SCHEMATIC WIRING DIAGRAMS - BLDGS. W-1 & W-4, W-SITE
21-MAY-56		0	UN	BLDGS. W-1, W-2, & W-4, W-SITE
21-SEP-60		2467	E	W-SITE INSTALLATION - ELECTRICAL - PLANS, NOTES, MATERIAL & NOTES, BLDG. W-1,4,6
30-SEP-60	29-SEP-60	2467	E	W-SITE ALARM INSTALL., BLDG. 1, ELECTRICAL - PLANS, NOTES & SCOPE
10-NOV-64		2981	UN	STILL INSTALLATION, BLDG. W-1, AREA 4, PLANS & ELEVATIONS
10-NOV-64		2981	UN	STILL INSTALLATION, BLDG. W-1, AREA 4, DETS., LIST OF EQUIP., DIAGRAM & NAMEPLAT
05-NOV-64		3115	E	REDISTRIBUTION OF POWER, BLDGS. W-1, & W-2, ELEC.-BLDG. W-1 LYOT, BILL OF MATL,
05-NOV-64		3115	E	REDISTRIBUTION OF POWER, BLDGS. W-1 & W-2, ELECT.-SINGLE LINE & BLDG. W-4 LAYOUT
05-NOV-64		3115	E	REDISTRIBUTION OF POWER, BLDGS. W-1 & W-2, ELECTRICAL - BLDG. W-2
05-APR-65		3116	G	LABORATORY INSTALLATION, BLDG. W-1 - PLANS & GENERAL NOTES
05-APR-65		3116	UN	PLANS - ELEVATIONS - DETAILS
05-APR-65		3116	UN	PLANS, ELEVATIONS - DETAILS
05-APR-65		3116	UN	LIST OF EQUIPMENT & SCHEDULES
05-APR-65		3116	F	ELECTRICAL - LIGHTING & FIRE PROTECTION PLANS & DIAGRAMS
05-APR-65		3116	G	ELECTRICAL - GENERAL NOTES, CONDUIT PLAN & WIRING DIAGRAMS
21-JAN-71		4561	E	HEAT DETECTOR INSTALLATION ELECTRICAL, BLDG. W-1
26-SEP-78	12-NOV-79	5940	E	UPGRADE VENTILATION SYS. MAIN VAULT AREA 5 ELEC; PARTIAL PLAN
				UPGRADE VENTILATION SYS. MAIN VAULT AREA 5 MECH;

41	1	C	43554	6	0
41	1	C	43554	1	0
41	1	C	43554	2	0
41	1	C	43554	5	0
41	1	C	43554	4	0
41	1	C	43554	7	0
41	1	C	43554	3	0
41	1	C	43698	6	1
41	1	C	43698	58	0
41	1	C	43698	59	0
41	1	C	43698	1	1
41	1	C	43698	3	1
41	1	C	43698	4	1
41	1	C	43698	5	1
41	1	C	43698	2	1
41	1	C	45394	9	0
41	1	C	45394	5	0
41	1	C	45394	1	0
41	1	C	45394	3	0
41	1	C	45394	3	0
41	1	C	45394	4	0

26-SEP-78	11-DEC-79	5940	M	EQUIPMENT LIST
26-SEP-78	11-DEC-79	5940	M	UPGRADE VENTILATION SYSTEM MAIN VAULT AREA 5 MECH; LOCATION AND PARTIAL PLANS
26-SEP-78	11-DEC-79	5940	M	UPGRADE VENTILATION SYS.. MAIN VAULT AREA 5 MECH; SECTIONS AND DETAIL
26-SEP-78	11-DEC-79	5940	M	UPGRADE VENTILATION SYS. MAIN VAULT AREA 5 MECH; NOTES
26-SEP-78	12-NOV-79	5940	M	UPGRADE VENTILATION SYS. MAIN VAULT AREA 5 MECH; DETAILS
26-SEP-78	11-DEC-79	5940	E	UPGRADE VENTILATION SYS. ELEC; BILL OF MATERIAL, NOTES NAMEPLATE SCHEDULE AND
26-SEP-78	11-DEC-79	5940	M	UPGRADE VENTILATION SYS. MAIN VAULT AREA 5 MECH; SECTIONS
17-JUL-79		6334	E	ELEC; UNDERGROUND VAULT AND TUNNEL
04-MAR-98	03-SEP-79	6334	C	FIRE PROTECTION IMPROVEMENTS, PLOT PLAN
04-MAR-98	03-SEP-79	6334	A	FIRE PROTECTION IMPROVEMENTS, FLOOR PLAN
17-JUL-79		6334	T	FIRE PROTECTION IMPROVEMENTS TITLE SHEET AND LOCATION PLAN BLDG. WA-1 TA-41
17-JUL-79		6334	M	MECH; SECTION
17-JUL-79		6334	E	ELEC; BLOCK DIAGRAM, NOTES AND NAMEPLATE
17-JUL-79		6334	E	ELEC; W-4 SECOND FLOOR PLAN
17-JUL-79		6334	M	MECH; FLOOR PLAN
01-APR-88	04-FEB-88	8739	G	REPLACE VENTILATION SYSTEM, GEN; SUBMITTAL SHEET
01-APR-88	04-FEB-88	8739	M	REPLACE VENTILATION SYSTEM, MECH; EQUIPMENT LIST, NOTES AND CLASS "A" EQUIPMENT CODE ASSIGNMENTS
01-APR-88	02-APR-88	8739	S	REPLACE VENTILATION SYSTEM, STRUCT; FOUNDATION & SUPPORT PLANS & DETAILS
01-APR-88	04-FEB-88	8739	M	REPLACE VENTILATION SYSTEM, MECH., & ELEC., DEMOLITION PLAN, ELEVATION
01-APR-88	04-FEB-88	8739	E	REPLACE VENTILATION SYSTEM, MECH., & ELEC., DEMOLITION PLAN, ELEVATION
01-APR-88	04-FEB-88	8739	M	REPLACE VENTILATION SYSTEM, MECH; FLOOR PLAN & SECURITY BAR DETAILS, HEPA FILTER PLENUM ELEVATIONS,



41	1	C	45394	6	0
41	1	C	45394	8	0
41	1	C	45394	6	0
41	1	C	45394	7	0
41	1	C	45394	2	0
41	1	C	45394	7	1
41	1	C	52050	4	0
41	1	C	52050	2	0
41	1	C	52050	5	0
41	1	C	52050	3	0
41	1	C	52050	1	0
41	1	R	2313	1	0
41	1	R	2314	1	0
41	1	R	2315	2	0
41	1	R	3137	1	3
41	1	SK	7686	1	0
41	1	SK	7686	2	0
41	1	SK	7686	3	0
41	1	SK	7686	4	0
41	1	SK	7686	5	0

LEGEND				
01-APR-88	05-FEB-88	8739	M	REPLACE VENTILATION SYSTEM, MECH; CONTROL SCHEMATIC, FAN, HEATING COIL, INLET VAN CONTROL WIRING DIAGRAM,
01-APR-88	04-FEB-88	8739	E	REPLACE VENTILATION SYSTEM, ELEC; LIGHTNING PROTECTION, BILL OF MATERIAL & NAMEPLATE SCHEDULES
01-APR-88	05-FEB-88	8739	E	REPLACE VENTILATION SYSTEM, MECH; CONTROL SCHEMATIC, FAN, HEATING COIL, INLET VAN CONTROL WIRING DIAGRAM,
01-APR-88	04-FEB-88	8739	E	REPLACE VENTILATION SYSTEM, ELEC; PLAN, NOTES & ONE LINE DIAGRAMS
01-APR-88	04-FEB-88	8739	S	REPLACE VENTILATION SYSTEM, STRUCT; EXHAUST STACK DETAILS, STACK & FAN CURB DETAILS & NOTES
30-APR-03	04-FEB-88	8739	E	REPLACE VENTILATION SYSTEM, ELEC; PLAN, NOTES & ONE LINE DIAGRAMS
24-JUN-99	17-AUG-98	18393	E	ELECTRICAL UPGRADES, ELEC., ONE-LINE DIAGRAM, BILL OF MATERIAL, GROUNDING LAYOUT & NAMEPLATE SCHEDULE
24-JUN-99	17-AUG-98	18393	E	ELECTRICAL UPGRADES, ELEC., DEMOLITION FLOOR PLAN
04-MAR-04	17-AUG-98	18393	E	ELECTRICAL UPGRADES, ELEC., PANELBOARD SCHEDULES
24-JUN-99	17-AUG-98	18393	E	ELECTRICAL UPGRADES, ELEC., POWER FLOOR PLAN
24-JUN-99	17-AUG-98	18393	E	ELECTRICAL UPGRADES, ELEC., SYMBOL, LEGEND & GENERAL NOTES
05-APR-62	22-DEC-61	0	A	FALLOUT SHELTER SURVEY, W-SITE, FLOOR PLAN
05-APR-62	18-DEC-61	0	A	FALLOUT SHELTER SURVEY, W-SITE, BASEMENT & FIRST FLOOR PLAN
05-APR-62	19-DEC-61	0	A	FALLOUT SHELTER SURVEY, W-SITE, SECOND FLOOR PLAN
20-DEC-63	06-MAR-84	0	A	FLOOR PLAN, UNDERGROUND VAULT
06-JUL-89		8739	C	REPA FILTER RELOCATION, BLDG. W-1, CIVIL/STRUCTURAL PLAN
06-JUL-89		8739	C	CIVIL/STRUCTURAL PLAN
06-JUL-89		8739	S	STRUCTURAL DETAILS
06-JUL-89		8739	UN	DEMOLITION PLAN
06-JUL-89		8739	UN	DEMOLITION PLAN

41	1	SK	7686	6	0	06-JUL-89	8739	M	MECHANICAL PLAN
41	1	SK	7686	7	0	06-JUL-89	8739	M	MECHANICAL PLAN
41	1	SK	7686	8	0	06-JUL-89	8739	F	FIRE PROTECTION PLAN
41	1	SK	7686	9	0	06-JUL-89	8739	M	MECHANICAL DETAILS
41	1	SK	7686	10	0	06-JUL-89	8739	UN	DETAILS

**REPORT FOR: DRAWINGS**

TA	BLDG	PREFIX	DRAWNUM	PAGE	REV	DSHEET	LOG_DATE	DOC_DATE	PROJID	DISC	TITLE
41	2	C	928	1	1		20-MAR-51	25-JUN-53	385	E	MOD. STANDBY ELECTRICAL POWER PLANT. PLOT PLAN, WIRING DIAGRAM & NOTES
41	2	C	929	2	1		20-MAR-51	25-JUN-53	385	E	MOD. STANDBY ELECTRICAL POWER PLANT SINGLE LINE DIA. & DETAILS
41	2	C	930	1	0		24-JUL-50	24-JUL-50	385	E	MOD. STANDBY ELECTRIC POWER PLANT. WIRING DIAGRAMS & CONTROL PANEL LAYOUT
41	2	C	931	2	0		24-JUL-50	24-JUL-50	385	E	MOD. STANDBY ELECTRICAL POWER PLANT. POWER PANEL ALTERATIONS & NOTES
41	2	C	959	1	2		19-AUG-50	19-AUG-50	632	C	TEMPORARY SITE ALTERATIONS, W-SITE. PLOT PLAN & DETS.
41	2	C	1592	16	1		12-MAY-53	06-DEC-50	145	A	EXPLOSIVE STORAGE PROJECT, W-SITE. ARCH. PLANS & SECTIONS. SENTRY HOUSE, W-2
41	2	C	1593	17	1		12-MAY-53	06-DEC-50	145	A	EXPLOSIVE STORAGE PROJECT, W-SITE. ARCH. ELEV. & DETAILS, SENTRY HOUSE, W-1
41	2	C	1594	18	1		12-MAY-53	06-DEC-50	145	S	EXPLOSIVE STORAGE PROJECT, W-SITE. STRUCT. DETAILS, SENTRY HOUSE, W-2
41	2	C	1595	19	1		12-MAY-53	06-DEC-50	145	S	EXPLOSIVE STORAGE PROJECT, W-SITE. STRUCT. DETAILS, SENTRY HOUSE, W-1
41	2	C	1607	31	2		12-MAY-53	06-DEC-50	145	A	EXPLOSIVE STORAGE PROJECT, W-SITE. UTILITY ROOM LAYOUT, SENTRY HOUSE, W-2
41	2	C	10888	1	0		27-JUN-56		0	E	WASTE TREATMENT PLANT, REVISION
41	2	C	16983	4	0		21-MAY-56		0	UN	BLDGS. W-2 & W-4, W-SITE
41	2	C	43712	1	0		03-OCT-79		5788	C	WEAPONS SAFEGUARDS CIVIL; GURAD STATION SPECIFICATIONS, LEGEND BLDG. W-2 TA-41
41	2	C	43712	5	0		03-OCT-79		5788	E	ELEC; GUARD STATION SCOPE OF WORK, NOTES, NAMEPLATE SCHEDULE AND LEGEND
41	2	C	43712	2	0		03-OCT-79		5788	C	CIVIL GUARD STATION FLOOR PLAN ELEVATIONS, SECTIONS, DOOR AND FINISH SCHEDULES
41	2	C	43712	4	0		03-OCT-79		5788	M	MECH; GUARD STATION MECH. EQUIP. LIST AND NOTES
41	2	C	43712	3	0		03-OCT-79		5788	M	MECH; GUARD STATION PLANS, PIPING ISOMETRICS, AND SECTIONS

41	2	C	43712	9	0
41	2	C	43712	7	0
41	2	C	43712	8	0
41	2	C	43712	6	0
41	2	C	43713	6	0
41	2	C	43713	8	0
41	2	C	43713	9	0
41	2	C	43713	7	0
41	2	C	43713	3	0
41	2	C	43713	5	0
41	2	C	43713	2	0
41	2	C	43713	4	0
41	2	C	43713	1	0
41	2	C	44520	26	0
41	2	C	44520	27	0
41	2	C	44520	30	0
41	2	C	44520	11	0
41	2	C	44520	10	0
41	2	C	44520	9	0
41	2	C	44520	28	0
41	2	C	44520	12	0

03-OCT-79		5788	E	ELEC; GUARD STATION DETAIL AND ELEVATION
03-OCT-79		5788	E	ELEC; GUARD STATION ELECTRICAL SYSTEMS LAYOUTS
03-OCT-79		5788	E	ELEC; GUARD STATION PANEL SCHEDULE "LP-1" AND WIRING DIAGRAM
03-OCT-79		5788	E	ELEC; GUARD STATION BILL OF MATERIAL
03-OCT-79		5788	E	ELEC; BILL OF MATERIALS, SCOPE, NOTES, NAMEPLATE SCHEDULE AND LEGEND
03-OCT-79		5788	E	ELEC; GUARD STATION ELECTRICAL SYSTEMS LAYOUTS AND SECTIONS
03-OCT-79		5788	E	ELEC; DETAILS AND SECTIONS
03-OCT-79		5788	E	ELEC; POWER PLOT PLAN AND WIRING DIAGRAM
03-OCT-79		5788	C	CIVIL; FLOOR PLAN, SECTION AND REMOVAL ELEVATION
03-OCT-79		5788	M	MECH; MECHANICAL NOTES AND ISOMETRICS
03-OCT-79		5788	C	CIVIL; PLOT PLAN AND TRENCHING DETAIL
03-OCT-79		5788	C	CIVIL; FENCING DETAILS
03-OCT-79		5788	G	WEAPONS SAFEGUARDS CIVIL; GENERAL NOTES AND LEGEND BLDG. W-2 TA-41
20-MAY-85	20-MAY-85	8065	E	SAFEGUARDS & SECURITY UPGRADES, POWER & LIGHTING, ELEC., PANEL "LP-2" AND "LP-3" SCHEDULE
20-MAY-85	20-MAY-85	8065	E	SAFEGUARDS & SECURITY UPGRADES, POWER & LIGHTING, ELEC., PANEL "PP-B" AND "LP-A" SCHEDULE
20-MAY-85	20-MAY-85	8065	E	SAFEGUARDS & SECURITY UPGRADES, POWER & LIGHTING, ELEC., BILL OF MATERIAL
20-MAY-85	20-MAY-85	8065	M	SAFEGUARDS & SECURITY UPGRADES, POWER & LIGHTING, MECH., FLOOR PLAN, LEGEND AND SECTIONS
20-MAY-85	20-MAY-85	8065	A	SAFEGUARDS & SECURITY UPGRADES, POWER & LIGHTING, ARCH., FINISH & DOOR SCHEDULES SECTIONS & ELEVATIONS
20-MAY-85	20-MAY-85	8065	A	SAFEGUARDS & SECURITY UPGRADES, POWER & LIGHTING, ARCH., ELEVATIONS
20-MAY-85	20-MAY-85	8065	E	SAFEGUARDS & SECURITY UPGRADES, POWER & LIGHTING, ELEC., CABLE & CONDUIT SCHEDULE NO. 101 THRU 150
20-MAY-85	20-MAY-85	8065	M	SAFEGUARDS & SECURITY UPGRADES, POWER & LIGHTING, MECH., PIPING SCHEMATIC & DETAIL, DIESEL FUEL TANK

41	2	C	44520	31	0
41	2	C	44520	29	0
41	2	C	44520	25	0
41	2	C	44520	19	0
41	2	C	44520	15	0
41	2	C	44520	7	0
41	2	C	44520	2	0
41	2	C	44520	8	0
41	2	C	44520	4	0
41	2	C	44520	24	0
41	2	C	44520	18	0
41	2	C	44520	18	0
41	2	C	44520	13	0
41	2	C	44520	6	0
41	2	C	44520	5	0
41	2	C	44520	1	0

20-MAY-85	20-MAY-85	8065	E	SAFEGUARDS & SECURITY UPGRADES, POWER & LIGHTING, ELEC., BILL OF MATERIAL
20-MAY-85	20-MAY-85	8065	E	SAFEGUARDS & SECURITY UPGRADES, POWER & LIGHTING, ELEC., BILL OF MATERIAL
20-MAY-85	20-MAY-85	8065	E	SAFEGUARDS & SECURITY UPGRADES, POWER & LIGHTING, ELEC., PANEL "PP-A" AND "PP-E" SCHEDULE
20-MAY-85	20-MAY-85	8065	E	SAFEGUARDS & SECURITY UPGRADES, POWER & LIGHTING, ELEC., GROUNDING LAYOUT & LIGHTNING PROTECTION LAYOUT
20-MAY-85	20-MAY-85	8065	E	SAFEGUARDS & SECURITY UPGRADES, POWER & LIGHTING, ELEC., ONE LINE DIAGRAM
20-MAY-85	20-MAY-85	8065	A	SAFEGUARDS & SECURITY UPGRADES, POWER & LIGHTING, ARCH., NOTES
20-MAY-85	20-MAY-85	8065	G	SAFEGUARDS & SECURITY UPGRADES, POWER & LIGHTING, GEN., SUBMITTALS
20-MAY-85	20-MAY-85	8065	A	SAFEGUARDS & SECURITY UPGRADES, POWER & LIGHTING, ARCH., FLOOR PLAN, SECTIONS DETAILS
20-MAY-85	20-MAY-85	8065	S	SAFEGUARDS & SECURITY UPGRADES, POWER & LIGHTING, STRUCT., FOUNDATION PLAN, SECTIONS & STRUCT., NOTES
20-MAY-85	20-MAY-85	8065	E	SAFEGUARDS & SECURITY UPGRADES, POWER & LIGHTING, ELEC., AREA LIGHTING WIRING DIAGRAMS & ENCLOSURE & PANEL LAYOUT
20-MAY-85	20-MAY-85	8065	F	SAFEGUARDS & SECURITY UPGRADES, POWER & LIGHTING, ELEC., LIGHTING & FIRE DETECTION SYSTEM LAYOUT
20-MAY-85	20-MAY-85	8065	E	SAFEGUARDS & SECURITY UPGRADES, POWER & LIGHTING, ELEC., LIGHTING & FIRE DETECTION SYSTEM LAYOUT
20-MAY-85	20-MAY-85	8065	M	SAFEGUARDS & SECURITY UPGRADES, POWER & LIGHTING, MECH., GENERAL PROVISIONS AND EQUIPMENT LIST
20-MAY-85	20-MAY-85	8065	S	SAFEGUARDS & SECURITY UPGRADES, POWER & LIGHTING, STRUCT., ROOF FRAMING PLAN, SECTIONS, DETAILS & NOTES
20-MAY-85	20-MAY-85	8065	S	SAFEGUARDS & SECURITY UPGRADES, POWER & LIGHTING, STRUCT., FOUNDATION PLAN BLDG, SECTIONS & ELEVATIONS
20-MAY-85	20-MAY-85	8065	E	SAFEGUARDS & SECURITY UPGRADES, POWER & LIGHTING, TITLE SHEET, LOCATION PLAN & INDEX OF DRAWINGS
				SAFEGUARDS & SECURITY UPGRADES, POWER & LIGHTING,

41	2	C	44520	23	0
41	2	C	44520	22	0
41	2	C	44520	21	0
41	2	C	44520	17	0
41	2	C	44520	16	0
41	2	C	44520	16	0
41	2	C	44520	14	0
41	2	C	46213	1	0
41	2	C	46213	2	0
41	2	C	46213	3	0
41	2	C	46213	5	0
41	2	C	46213	8	0
41	2	C	49398	1	1
41	2	C	49398	3	0
41	2	C	49398	5	0
41	2	R	1958	1	0
41	2	R	3138	1	2

20-MAY-85	20-MAY-85	8065	E	ELEC., MISCELLANEOUS WIRING DIAGRAMS
20-MAY-85	20-MAY-85	8065	E	SAFEGUARDS & SECURITY UPGRADES, POWER & LIGHTING, ELEC., ELEVATIONS & DETAILS, TRANSFORMER SUPPORT
20-MAY-85	20-MAY-85	8065	E	SAFEGUARDS & SECURITY UPGRADES, POWER & LIGHTING, ELEC., EXTERIOR LIGHTING LAYOUTS
20-MAY-85	20-MAY-85	8065	E	SAFEGUARDS & SECURITY UPGRADES, POWER & LIGHTING, ELEC., POWER LAYOUT
20-MAY-85	20-MAY-85	8065	E	SAFEGUARDS & SECURITY UPGRADES, POWER & LIGHTING, ELEC., POWER PLOT PLAN
20-MAY-85	20-MAY-85	8065	C	SAFEGUARDS & SECURITY UPGRADES, POWER & LIGHTING, ELEC., POWER PLOT PLAN
20-MAY-85	20-MAY-85	8065	E	SAFEGUARDS & SECURITY UPGRADES, POWER & LIGHTING, ELEC., NAMEPLATE SCHEDULE, NOTES AND SCOPE OF WORK
31-MAR-92	11-MAR-92	12400	T	INSTALL UNDERGROUND STORAGE TANK, TITLE SHEET AND INDEX TO DRAWINGS
31-MAR-92	11-MAR-92	12400	C	INSTALL UNDERGROUND STORAGE TANK, CIVIL, LOCATION PLANS
31-MAR-92	11-MAR-92	12400	G	INSTALL UNDERGROUND STORAGE TANK, GEN., SUBMITTALS, INSPECTION PLAN & TEST PLAN SCHECULES
31-MAR-92	11-MAR-92	12400	C	INSTALL UNDERGROUND STORAGE TANK, CIVIL, SITE PLAN AND CONCRETE VAULT DETAILS, SCHEMATIC
31-MAR-92	11-MAR-92	12400	C	INSTALL UNDERGROUND STORAGE TANK, CIVIL, DETAILS AND SECTIONS
18-NOV-93		14613	E	UPS UPGADE, ELEC; NOTES, NAMEPLATE SHCEDULE, B.O.M. AND SCOPE OF WORK, BLDG. W-2
18-NOV-93		14613	E	ELEC; DEMOLITION PLAN, ELEVATION AND KEYED NOTES
17-NOV-93		14613	E	ELEC; POWER PLAN, SECTIONS AND KEYED NOTES
11-JAN-63		0	F	FIRE ALARM EQUIPMENT, BLDG. W-2, FIRST & SECOND FLOOR PLANS
17-JUL-64	06-FEB-84	0	A	FIRST & SECOND FLOOR PLAN, GUARD HOUSE

**REPORT FOR: DRAWINGS**

TA	BLDG	PREFIX	DRAWNUM	PAGE	REV	DSHEET	LOG_DATE	DOC_DATE	PROJID	DISC	TITLE
41	3	R	3377	1	3		31-JAN-63	06-MAR-84	0	A	FLOOR PLAN, BOILER HOUSE

TA	BLDG	PREFIX	DRAWNUM	PAGE	REV	DSHEET	LOG_DATE	DOC_DATE	PROJID	DISC	TITLE
41	4	AB	120	1	0		06-Jun-94	15-May-94	7556	A	AS-BUILT REOCDR FLOOR PLAN LABORATORY BUILDING, BASEMENT FLOOR PLAN
41	4	AB	120	2	0		06-Jun-94	13-May-94	7556	A	AS-BUILT RECORD FLOOR PLAN LABORATORY BUILDING, FIRST FLOOR PLAN
41	4	AB	120	3	0		06-Jun-94	15-May-94	7556	A	AS-BUILT RECORD FLOOR PLAN LABORATORY BUILDING, SECOND FLOOR PLAN
41	4	C	1043	1	1		30-Apr-65	30-Apr-65	3232	M	MASS SPECTROMETER INSTALLATION, MECHANICAL
41	4	C	1044	2	1		30-Apr-65	30-Apr-65	3232	E	MASS SPECTROMETER INSTALLATION, ROOM 125, BLDG. W-4. ELECTRICAL
41	4	C	1761	1	1		08-Jul-52	11-Jul-53	1250	M	DRY BOX INSTALLATION, ELECT, MECH., PLAN SECTIONS AND DETAILS, RM. 125,
41	4	C	2058	1	1		20-Dec-52	05-Dec-52	1340	S	DEHUMIDIFICATION, RM. 236A, BLDG. 4. STRUCTURAL PLANS & DETAILS
41	4	C	2059	2	1		20-Dec-52	05-Dec-52	1340	S	DEHUMIDIFICATION, RM. 236A, BLDG. 4. STRUCTURAL PLANS & DETAILS. SHEET METAL
41	4	C	2060	3	1		20-Dec-52	04-Dec-52	1340	S	DEHUMIDIFICATION, RM. 236A, BLDG. 4. SECOND FLOOR STRENGTHENING. STRUCTURAL
41	4	C	2061	4	1		20-Dec-52	05-Dec-52	1340	M	DEHUMIDIFICATION, RM. 236A, BLDG. 4. MECH. PLAN & SECTION
41	4	C	2062	5	1		20-Dec-52	05-Dec-52	1340	M	DEHUMIDIFICATION, RM. 236A, BLDG. 4. MECH. UTILITY TUNNEL & FIRST FLOOR PLAN
41	4	C	2063	6	1		20-Dec-52	05-Dec-52	1340	M	DEHUMIDIFICATION, RM. 236A, BLDG. 4. MECH. SECTIONS & DETAILS
41	4	C	2064	7	1		20-Dec-52	05-Dec-52	1340	M	DEHUMIDIFICATION, RM. 236A, BLDG. 4. MECH. SECTION & DETAILS
41	4	C	2065	8	2		20-Dec-52	05-Dec-52	1340	E	DEHUMIDIFICATION, RM. 236A, BLDG. 4. ELECT. PLANS & NOTES, UTILITY TUNNEL & SEC
41	4	C	2066	9	2		20-Dec-52	05-Dec-52	1340	E	DEHUMIDIFICATION, RM. 236A, BLDG. 4. ELECT. WIRING DIA. & MATERIALS
41	4	C	2067	10	1		20-Dec-52	05-Dec-52	1340	E	DEHUMIDIFICATION, RM 236A, BLDG. 4. ELECTRICAL DETAILS
41	4	C	2561	1	1		29-Jan-52	29-Dec-51	1068	M	TEMPERATURE CONTROL FOR RMS. 236 & 237, BLDG. #4
41	4	C	2562	2	1		29-Jan-52	29-Dec-51	1068	A	TEMPERATURE CONTROL FOR RMS. 236 & 237, BLDG. #4 PARTITION DETAILS
41	4	C	2576	1	1		10-Feb-52	10-Jan-52	1075	A	INSTALLATION LAB. BENCH, SINK AND STAND, RM. 219, BLDG. R-4
41	4	C	2578	1	0		12-Feb-52	12-Jan-52	1076	A	LADDER & PLATFORM, BLDG. W-4
41	4	C	2690	1	1		05-Jun-52	05-May-52	1164	M	MODIFY AIR CONDITIONING SYSTEM (EXCLUSION AREA) BLDG. W-4, MECH.
41	4	C	2691	2	1		05-Jun-52	05-May-52	1164	A	MODIFY AIR CONDITIONING SYSTEM (EXCLUSION AREA) BLDG. W-4, ARCH.
41	4	C	2698	1	1		29-May-52	29-Apr-52	1163	AC	AIR CONDITIONING OF ROOM 115, BLDG. W-4
41	4	C	2761	1	0		09-Jul-52	09-Jun-52	442	E	MODIFICATIONS OF G.E. MODEL 6RB 82Y2 BATTERY CHARGER, BLDG. W-4
41	4	C	2762	2	0		09-Jul-52	09-Jun-52	442	E	OUTLINE OF CONTROL PANEL SHOWING TAP & RANGE SWITCH POSITION, BLDG. W-4
41	4	C	2770	1	1		10-Jul-52	10-Jun-52	1197	E	BATTERY CHARGER ALTERATIONS, ROOM 127-D; BLDG. W-4 ELECT. PLAN
41	4	C	2771	2	1		10-Jul-52	10-Jun-52	1197	E	BATTERY CHARGER ALTERATIONS, ROOM 127-D, WIRING DIAGRAM
41	4	C	2772	3	1		10-Jul-52	10-Jun-52	1197	E	BATTERY CHARGER ALT., MOCK WIRING DETAILS & BATTERY CHARGER WIRING DIA.
41	4	C	2855	1	1		06-Nov-52	06-Oct-52	1322	A	MONORAIL INSTALL, RM. 240, BLDG. W-4 PLAN & DETAILS
41	4	C	10848	1	0		16-Nov-54	10-Nov-54	1661	M	HEATING & VENT. SYS. DESIGN MOD., FIRST AND SECOND FLOOR
41	4	C	10849	2	1		21-Jan-92	10-Nov-54	1661	M	HEATING & VENT. SYSTEM DESIGN MOD., FAN RM. UTILITY RM. & TUNN
41	4	C	10850	3	0		16-Nov-54	10-Nov-54	1661	M	HEATING & VENTILATING SYS., CONTROL DIAGRAMS & EQUIPMENT SCHEDULE
41	4	C	10910	1	0		05-Apr-55	29-Mar-55	1677	M	MOD. CHEMICAL FUME HOODS, BLDG. W-4, ELECT. PLAN & DETAILS
41	4	C	15124	13	1		08-Jun-53		442	UN	UTILITY TUNNEL PLAN (NO. 4) W-4
41	4	C	15125	14	2		08-Jun-53		442	A	FIRST FLOOR PLAN, BLDG. W-4
41	4	C	15126	15	1		08-Jun-53		442	A	SECOND FLOOR PLAN, BLDG. W-4



41	4	C	15127	16	1	21-Jan-92	442	UN	ELEVATIONS BUILDING W-4 PROJECT TA-41 (AS-BUILTS)
41	4	C	15128	17	1	21-Jan-92	442	UN	ELEVATIONS & SECTIONS BUILDING W-4 PROJECT TA-41 (AS-BUILTS)
41	4	C	15129	18	0	08-Jun-53	442	UN	ROOF PLAN, SECTIONS & MISC. EXTERIOR DETAILS, BLDG. W-4
41	4	C	15130	19	0	08-Jun-53	442	UN	WALL SECTIONS, BLDG. W-4
41	4	C	15131	20	0	08-Jun-53	442	UN	WINDOW & DOOR DETAILS, BLDG. W-4
41	4	C	15132	21	0	08-Jun-53	442	UN	STAIR & ELEVATOR DETAILS BLDG. W-4
41	4	C	15133	22	1	08-Jun-53	442	UN	1/4 SCALE TOILET ROOM PLANS & METAL PARTITION DETAILS, BLDG. W-4
41	4	C	15134	23	0	08-Jun-53	442	UN	MISCELLANEOUS DETAILS, BLDG. W-4
41	4	C	15135	24	0	08-Jun-53	442	UN	FIRST FLOOR EQUIPMENT LAYOUT BLDG. W-4
41	4	C	15136	25	0	08-Jun-53	442	UN	SECOND FLOOR EQUIPMENT LAYOUT BLDG. W-4
41	4	C	15137	26	0	08-Jun-53	442	UN	EQUIPMENT SCHEDULE & DETAILS BLDG. W-4
41	4	C	15138	27	1	08-Jun-53	442	UN	FIRST FLOOR REFLECTED CEILING PLAN, DET. & RM. FINISH SCHED., BLDG. W-4
41	4	C	15139	28	0	08-Jun-53	442	UN	SECOND FLOOR REFLECTED CEILING PLAN, BLDG. W-4
41	4	C	15142	31	1	08-Jun-53	442	E	EXTENSION OF ELECTRICAL SERVICES BLDG. W-4 TO BLDG. W-2
41	4	C	15143	32	1	08-Jun-53	442	UN	FOUNDATION AND UTILITY TUNNEL PLAN, BLDG. W-4
41	4	C	15144	33	1	08-Jun-53	442	UN	FIRST FLOOR FRAMING PLAN BLDG. W-4
41	4	C	15145	34	1	08-Jun-53	442	UN	SECOND FLOOR FRAMING PLAN BLDG. W-4
41	4	C	15146	35	0	08-Jun-53	442	UN	ROOF FRAMING PLAN BLDG. W-4
41	4	C	15147	36	0	08-Jun-53	442	UN	COUNTING ROOM & CORRIDOR DETAILS BLDG. W-4
41	4	C	15148	37	0	08-Jun-53	442	UN	GENERAL NOTES, SCHEDULES & TYPICAL DETAILS, BLDG. W-4
41	4	C	15149	38	1	08-Jun-53	442	UN	CONCRETE WALL SECTIONS BLDG. W-4
41	4	C	15150	39	0	08-Jun-53	442	UN	CONCRETE WALL SECTIONS & DETAILS BLDG. W-4
41	4	C	15151	40	0	08-Jun-53	442	UN	STEEL DETAILS & SECTIONS BLDG. W-4
41	4	C	15152	41	0	08-Jun-53	442	UN	MISCELLANEOUS SECTIONS & DETAILS BLDG. W-4
41	4	C	15153	42	0	08-Jun-53	442	A	FIRST FLOOR PLAN BLDG. W-4
41	4	C	15154	43	0	08-Jun-53	442	A	SECOND FLOOR PLAN BLDG. W-4
41	4	C	15155	44	0	08-Jun-53	442	UN	UTILITY ROOM & FAN ROOM, PLANS & DETAILS, BLDG. W-4
41	4	C	15156	45	0	08-Jun-53	442	UN	FIRST & SECOND FLOOR SECTIONS BLDG. W-4
41	4	C	15157	46	0	15-Nov-50	442	M	PIPING DETAILS
41	4	C	15158	47	0	08-Jun-53	442	UN	UTILITY TUNNEL PLAN BLDG. W-4
41	4	C	15159	48	0	08-Jun-53	442	A	FIRST FLOOR PLAN BLDG. W-4
41	4	C	15160	49	0	08-Jun-53	442	A	SECOND FLOOR PLAN BLDG. W-4
41	4	C	15161	50	0	08-Jun-53	442	UN	ISOMETRIC PIPING DIAGRAMS BLDG. W-4
41	4	C	15162	51	1	21-Jan-92	442	UN	UTILITY TUNNEL SECTIONS BUILDING W-4 PROJECT TA-41 (AS-BUILTS)
41	4	C	15163	52	0	08-Jun-53	442	UN	UTILITY ROOM & FAN ROOM PLAN, SECTIONS & DETAILS, BLDG. W-4
41	4	C	15164	53	1	21-Jan-92	442	UN	PLANS, SECTIONS & DETAILS BUILDING W-4 PROJECT TA-41 (AS-BUILTS)
41	4	C	15165	54	0	08-Jun-53	442	F	FIRST & SECOND FLOOR PLANS SPRINKLER SYSTEM, BLDG W-4
41	4	C	15166	55	1	21-Jan-92	442	UN	SECTIONS & DETAILS - SFPRINKLER SYSTEM BUILDING W-4, PROJECT TA-41 (AS-BUIL)
41	4	C	15167	56	1	08-Jun-53	442	UN	SYMBOLS & FIXTURE SCHEDULE
41	4	C	15172	61	2	08-Jun-53	442	E	CONDUIT & FEEDER DIAGRAM, ELECTRIC & TELEPHONE , BLDG. W-4
41	4	C	15173	62	2	08-Jun-53	442	UN	UTILITY, FAN & EQUIPMENT ROOM, PLAN & SECTIONS, BLDG. W-4

41	4	C	15174	63	3		21-Jan-92		442	F	UTILITY TUNNEL FEEDER, FIRE ALARM & LIGHTING PLAN BUILDING W-4, PROJECT TA-41
41	4	C	15175	64	3		08-Jun-53		442	UN	FIRST FLOOR RECEPTACLE PLAN BLDG. W-4
41	4	C	15176	65	2		08-Jun-53		442	E	FIRST FLOOR LIGHTING PLAN BLDG. W-4
41	4	C	15177	66	2		08-Jun-53		442	UN	SECOND FLOOR RECEPTACLE PLAN BLDG. W-4
41	4	C	15178	67	2		08-Jun-53		442	UN	SECOND FLOOR LIGHTING PLAN BLDG. W-4
41	4	C	15179	68	1		08-Jun-53		442	E	LABORATORY PANELS & BATTERY, SELECTOR PANEL DET., BLDG. W-4
41	4	C	15180	69	1		08-Jun-53		442	UN	D.C DISTRIBUTION SWITCHBOARD DETAILS, BLDG. W-4
41	4	C	15181	70	1		08-Jun-53		442	UN	D.C. DISTRIBUTION WIRING DIAGRAMS BLDG. W-4
41	4	C	15182	71	3		08-Jun-53		442	UN	PANEL & SWITCHBOARD SCHEDULE BLDG. W-4
41	4	C	15183	72	2		08-Jun-53		442	F	FIRST FLOOR TELEPHONE, FIRE AND INTRUSION ALARM PLAN, BLDG. W-4
41	4	C	15184	73	1		08-Jun-53		442	F	SECOND FLOOR TELEPHONE, FIRE AND INTRUSION ALARM PLAN, BLDG. W-4
41	4	C	15185	74	2		30-Sep-53	30-Sep-53	442	F	WIRING DIAGRAMS INTRUSION & FIRE ALARM SYSTEMS
41	4	C	16981	2	0		21-May-56		0	UN	BLDG. W-4, W-SITE
41	4	C	16982	3	0		21-May-56		0	UN	BLDGS. W-1 & W-4, W-SITE
41	4	C	16985	6	0		21-May-56		0	UN	BLDGS. W-4 & W-7, W-SITE
41	4	C	17191	1	0		15-Aug-56	09-Aug-56	0	M	RUEMELIN UNIT INSTALLATION BLDG. W-4 - PLAN AND DETAILS
41	4	C	17192	2	0		15-Aug-56	09-Aug-56	0	M	NOTES AND EQUIPMENT ELECTRICAL - PLAN AND DETAILS
41	4	C	18295	1	0		23-Jan-61		2513	E	ADDITIONAL POWER INSTALLATION, BLDG. W-4 - ELECTRICAL - PLAN, MATERIAL & NOTES
41	4	C	18296	2	1		21-Jan-92		2513	E	ADDITIONAL POWER INSTALLATION - BLDG. W-4 - ELECTRICAL DETAILS & WIRING DIAGRAM
41	4	C	18542	1	1		28-May-59		2069	C	SITE ENTRANCE & ROAD ACCESS, W-4 - CIVIL - LOCATION & PLOT PLAN
41	4	C	18543	2	1		28-May-59		2069	S	STRUCTURAL - PLAN & DETAILS
41	4	C	18743	1	0		08-May-61		2539	AC	SONIC CLEANER VENTILATION, ROOM 233, BLDG. W-4 - ELEC. & MECH. PLAN, SECTIONS &
41	4	C	18795	1	0		07-May-58		2105	S	JIB CRANE INSTALLATION, RM.236, BLDG. W-4 - STRUCTURAL - PLAN & DETAILS
41	4	C	18858	1	0		09-Oct-59		2162	A	OCCUPANCY MODIFICATIONS BLDG. W-4 - LOCATION & FLOOR PLANS
41	4	C	18859	2	0		09-Oct-59		2162	UN	BLDGS. W-4 & W-30 EQUIP. SCHEDULE & DETAILS
41	4	C	18860	3	0		31-Oct-58		2162	A	ARCHITECTURAL DETAILS
41	4	C	18861	4	0		25-Nov-58	06-Nov-58	2162	F	OCCUPANCY MODIFICATIONS, FIRE DOOR SPECIFICATIONS
41	4	C	18862	1	1		21-Jan-92		2162	M	OCCUPANCY MODIFICATIONS - BLDG. W-4 - MECH; VACUUM BENCH INSTALLATION, BLDG. W-4
41	4	C	18978	1	1		14-Mar-57	12-Mar-57	1885	C	MASS SPECTROMETER INSTALLATION, CIVIL AND MECHANICAL PLAN
41	4	C	18979	2	1		14-Mar-57	12-Mar-57	1885	M	MASS SPECTROMETER INSTALLATION, TUNNEL PLAN AND DETAILS
41	4	C	18980	3	1		14-Mar-57	12-Mar-57	1885	E	MASS SPECTROMETER INSTALLATION, ONE LINE DIAGRAM
41	4	C	18981	4	1		14-Mar-57	12-Mar-57	1885	E	MASS SPECTROMETER INSTALLATION, PLAN
41	4	C	18982	5	1		14-Mar-57	12-Mar-57	1885	E	MASS SPECTROMETER INSTALLATION, WIRING DIAGRAM
41	4	C	18983	6	1		14-Mar-57	12-Mar-57	1885	M	MASS SPECTROMETER INSTALLATION, BILL OF MATERIAL
41	4	C	19031	12	0		06-Jul-59	08-Apr-57	1849	A	ENGINEERING & LAB. BLDG., SERV. - FIRST FLOOR W-4 ANNEX
41	4	C	19032	12	0		06-Jul-59	08-Apr-57	1849	A	ENGINEERING & LAB. BLDG., SECOND FLOOR W-4 ANNEX
41	4	C	19033	14	0		06-Jul-59	08-Apr-57	1849	A	ENGINEERING & LAB. BLDG., SERVICES - SECOND FLOOR W-4 ANNEX
41	4	C	19152	1	2		21-Jan-92		3008	M	VACUUM BENCH INSTALLATION, ROOM 236A, BLDG. W-4 - MECHANICAL (AS-BUILTS)
41	4	C	19153	2	1		14-Feb-64		3008	E	ELECTRICAL
41	4	C	19520	1	0		02-Sep-60		2380	AC	AIR CONDITIONING EQUIP. MODS., RMS. 123 & 126, BLDG. W-4 - MECHANICAL - PLAN
41	4	C	19521	2	0		02-Sep-60		2380	M	MECHANICAL - SECTIONS & DETAILS

41	4 C	19522	3	0	02-Sep-60	2380	E	ELECTRICAL - PLANS, NOTES, SCOPE & MATERIAL
41	4 C	19534	1	0	25-Nov-57	2083	UN	WELDER COOLING SYSTEM MODIFICATIONS, ICE HOUSE DOCK, BLDG. W-4 - PLAN & DETAILS
41	4 C	21237	1	1	21-Jan-92	2162	E	OCCUPANCY MODS., ELECTRICAL BUILDING W-4, ANNEX - 480 VOLT FEEDER INSTALLATION D
41	4 C	21410	5	0	09-Feb-59	2162	F	OCCUPANCY MODIFICATIONS, BLDG. W-4 - FIRE DOOR SPECIFICATIONS
41	4 C	21411	6	0	03-Mar-59	2162	A	ARCHITECTURAL - DETAILS
41	4 C	21417	1	0	23-Apr-59	2162	M	MECHANICAL - DETAILS ( MASS SPECTROMETER INSTALLATION)
41	4 C	21418	2	0	23-Apr-59	2162	M	MECHANICAL - PLAN & SECTION (MASS SPECTROMETER INSTALLATION)
41	4 C	21419	3	0	23-Apr-59	2162	E	ELECTRICAL - PLAN, SCOPE & NOTES (MASS SPECTROMETER INSTALLATION)
41	4 C	23284	1	1	28-Aug-59	2162	A	OCCUPANCY MODIFICATIONS, BLDG. W-4, W-30 - LOCATION & FLOOR PLANS
41	4 C	23285	2	0	28-Aug-59	2162	UN	EQUIPMENT SCHEDULE & DETAILS
41	4 C	23286	3	1	21-Jan-92	2162	UN	OCCUPANCY MODIFICATIONS, ROOF PLAN-STACK INSTALLATION BLDGS. W-4 & W-30 (AS-
41	4 C	23287	4	0	28-Aug-59	2162	M	MECHANICAL - LABORATORY SERVICES & LEGEND
41	4 C	23288	5	0	28-Aug-59	2162	M	MECHANICAL - SCHEMATIC LAB. FURNITURE, PIPING DIAGRAM
41	4 C	23289	6	0	28-Aug-59	2162	A	FIRST & SECOND FLOOR PLANS, PIPING CHASE, FL. SLV. & CLG. PIPING
41	4 C	23290	7	0	28-Aug-59	2162	UN	UTILITY TUNNEL PIPING PLAN
41	4 C	23291	8	0	28-Aug-59	2162	M	MECHANICAL - PIPING SECTIONS & DETAILS
41	4 C	23292	9	0	28-Aug-59	2162	M	MECHANICAL - TYP. VAC. HOOD INSTL., PL., SECTS. & DETAILS
41	4 C	23293	10	0	28-Aug-59	2162	UN	ROOF PLAN, AIR SUPPLY & EXHAUST SYSTEMS
41	4 C	23294	11	0	28-Aug-59	2162	AC	HEATING & VENTILATING PLANS, SECTIONS & DETAILS
41	4 C	23295	12	0	28-Aug-59	2162	M	MECHANICAL - AIR SUPPLY UNIT NO. 1
41	4 C	23296	13	0	28-Aug-59	2162	M	MECHANICAL - AIR SUPPLY UNIT NO. 2, SECTION
41	4 C	23297	14	0	28-Aug-59	2162	M	MECHANICAL SCHEMATIC CONTROL DIAGRAM
41	4 C	23298	15	0	28-Aug-59	2162	M	MECH. CONTROL PANEL DETAILS
41	4 C	23299	16	0	28-Aug-59	2162	M	MECH. - STEAM DISTRIBUTION PLAN
41	4 C	23300	17	0	28-Aug-59	2162	M	MECHANICAL STEAM COIL PIPING DIAGRAM
41	4 C	23301	18	0	28-Aug-59	2162	M	MECH. - SECTIONS AND DETAILS
41	4 C	23302	19	0	28-Aug-59	2162	G	MECHANICAL - GENERAL NOTES
41	4 C	23303	20	0	28-Aug-59	2162	M	MECHANICAL - EQUIPMENT LIST
41	4 C	23304	21	0	28-Aug-59	2162	M	MECHANICAL - EQUIPMENT LIST
41	4 C	23305	22	0	28-Aug-59	2162	E	ELEC. - PLAN, SCOPE, NOTES, MATERIAL LIST
41	4 C	23306	23	0	28-Aug-59	2162	E	ELECTRICAL - NAMEPLATE SCHEDULE
41	4 C	23307	24	0	28-Aug-59	2162	E	ELECTRICAL - SINGLE LINE DIAGRAM
41	4 C	23308	25	0	28-Aug-59	2162	E	ELECTRICAL - AC PANEL ONE LINE DIAGRAMS
41	4 C	23309	26	0	28-Aug-59	2162	E	ELECTRICAL PLAN - LIGHTING
41	4 C	23310	27	0	28-Aug-59	2162	E	ELECTRICAL PLAN - POWER
41	4 C	23311	28	0	28-Aug-59	2162	E	ELECTRICAL - PLAN - ROOF
41	4 C	23312	29	0	28-Aug-59	2162	E	ELECTRICAL - PLAN SOUTH UTILITY TUNNEL
41	4 C	23313	30	0	28-Aug-59	2162	E	ELECTRICAL - ELEMENTARY DIAGRAM
41	4 C	23314	31	0	28-Aug-59	2162	E	ELECT. - AC PANEL DETAILS
41	4 C	23315	32	0	28-Aug-59	2162	E	ELECTRICAL - CONTROL PANEL, NO. 1 & NO. 2
41	4 C	23316	33	0	28-Aug-59	2162	E	ELECTRICAL - D.C. SWITCHBOARD DETAILS



41	4C	23317	34	0	28-Aug-59		2162	E	ELECTRICAL - MULTI-OUTLET ASSEMBLY DETAILS
41	4C	23661	2	0	21-Sep-60		2467	E	ELECTRICAL PLANS & DETAILS, BLDGS. #W-4 & W-30
41	4C	23858	14	0	16-Oct-59		1849	A	ARCHITECTURAL, W-4 ANNEX
41	4C	23861	17	0	16-Oct-59		1849	A	ARCHITECTURAL W-4 ANNEX
41	4C	23880	36	0	16-Oct-59		1849	S	STRUCTURAL W-4 ANNEX
41	4C	23881	37	0	16-Oct-59		1849	S	STRUCTURAL W-4 ANNEX
41	4C	23885	41	0	16-Oct-59		1849	UN	PLUMBING W-4 ANNEX
41	4C	23888	44	0	16-Oct-59		1849	AC	AIR CONDITIONING & VENTILATION, W-4 ANNEX
41	4C	25908	1	0	11-Oct-60	11-Oct-60	2162	A	OCCUPANCY MODIF., BLDG. W-4 & BLDG. W-30, ADDITIONAL IMPROVEMENTS, BUMPER LOGS & CO
41	4C	26107	1	0	03-Aug-62	30-Jul-62	2762	AC	VENTILATION MODS., BLDG. W-4, (AREAS 4A, 4B & 4C) PLANS, ELEVATIONS, SECTIONS
41	4C	26227	1	0	23-Jan-63		2851	M	VACUUM BENCH EXHAUST INSTALLATION, ROOM 236, BLDG. W-4, MECHANICAL - SECTION, DE
41	4C	26311	1	0	03-Aug-61		2578	UN	VAC BENCH, HOIST & MANIFOLD INSTALLATION, RMS. 102, 106 & 236, BLDG. W-4, MONORA
41	4C	26312	2	0	03-Aug-61		2578	UN	STACK INSTALLATION DETAILS
41	4C	26313	3	0	03-Aug-61		2578	M	MECHANICAL - PLAN & PIPING DIAGRAM
41	4C	26314	4	0	03-Aug-61		2578	M	MECHANICAL - SECTIONS, EQUIPMENT LIST & NOTES
41	4C	26315	5	0	03-Aug-61		2578	E	ELECTRICAL - PLAN, SCOPE, NOTES & MATERIAL
41	4C	26629	1	0	26-Jan-62		2705	S	SECURITY SCREENS, ROOM 102, BLDG. W-4, STRUCTURAL - PLANS & DETAILS
41	4C	27217	1	0	02-May-62		2674	UN	BLAST SHIELD & JIB CRANE INSTALLATION, RMS. 256 & 262, BLDG. W-4, PLAN & DETAILS
41	4C	27603	1	0	10-Apr-64		3044	M	COMPRESSOR INSTALLATION, ROOMS 256 & 258, BLDG. W-4, MECHANICAL-PIPING PLANS, SE
41	4C	27604	2	0	10-Apr-64		3044	M	COMPRESSOR INSTALLATION, ROOMS 256, & 258, BLDG. W-4, MECHANICAL - DIAGRAM & DET
41	4C	27605	3	0	10-Apr-64		3044	M	COMPRESSOR INSTALLATION, ROOMS 256 & 258, BLDG. W-4, MECHANICAL - MANIFOLD PLANS
41	4C	27606	4	0	10-Apr-64		3044	E	COMPRESSOR INSTALLATION, ROOMS 256 & 258, BLDG. W-4, ELECTRICAL - PLAN, WIRING,
41	4C	27884	1	0	27-Feb-64		2981	G	STILL INSTALLATION, BLDG. W-1, AREA 4, PLANS, ELEVATIONS, DETAILS & GENERAL NOTE
41	4C	27885	2	0	27-Feb-64		2981	UN	STILL INSTALLATION, BLDG. W-1, AREA 4, SINGLE LINE DIAGRAM, DETAIL, NAMEPLATE SC
41	4C	29189	1	0	16-Jul-62		2584	AC	VENTILATING SYSTEM, MODIFICATIONS, BLDG. W-4 & ANNEX - LOCATION & STACK FOUNDATIO
41	4C	29190	2	0	16-Jul-62		2584	UN	STACK DETAILS
41	4C	29191	3	0	16-Jul-62		2584	M	MECHANICAL - ROOF PLAN
41	4C	29192	4	0	16-Jul-62		2584	M	MECHANICAL - SECTIONS & DETAILS
41	4C	29193	5	0	16-Jul-62		2584	E	ELECTRICAL - PLANS & DETAILS
41	4C	29653	1	1	21-Jan-92		3100	G	SECURITY MOD - LOC.PLAN, ARCH. & MECH FLOOR PLAN, MECH EQUIP LIST, DET. & GENERA
41	4C	29654	2	1	21-Jan-92		3100	UN	SECURITY MOD - FENCE, MONORAIL & GUARD STATION DETAILS, DOOR A DETAILS, BLDG. W-
41	4C	29655	3	1	21-Jan-92		3100	AC	SECURITY MOD - SECTIONS, DETAILS, DOOR B DETAIL, & MECH. VENTILATING BLDG. W-4
41	4C	29656	4	0	22-Jul-64		3100	E	ELECTRICAL - PLANS
41	4C	29657	5	0	22-Jul-64		3100	E	ELECTRICAL - SCOPE, NOTES & MATERIAL
41	4C	29659	1	0	20-Feb-63		2787	AC	AIR CONDITIONING MODS., ROOM 126, BLDG. W-4 - PLAN, SECTION, DETAILS & NOTES
41	4C	29660	2	0	20-Feb-63		2787	E	ELECTRICAL - PLAN
41	4C	33909	1	1	21-Jan-92		4660	AC	VENTILATION & TEMPERATURE CONTROL, BLDG. W-4 & W-30, MECHANICAL PLAN AND NOTES
41	4C	33910	2	1	21-Jan-92		4660	AC	VENTILATION & TEMPERATURE CONTROL, BLDGS. W-4 & W-30 -MECH-DETAILS SECTIONS EQUI
41	4C	33911	3	1	21-Jan-92		4660	AC	VENTILATION & TEMPERATURE CONTROL BLDGS. W-4 & W-30 ELECT. PLAN MATERIAL NOTES
41	4C	34107	1	0	30-Oct-67		3716	S	STRESS COAT HOOD FACILITY STRUCTURAL - BLDG. ANNEX W-4
41	4C	34108	2	0	30-Oct-67		3716	M	MECHANICAL - PLANS & DETAILS - STRUCTURAL - DETAILS BLDG. W-4 ANNEX

41	4 C	34109	3	0	30-Oct-67	3716	M	MECHANICAL - EQUIPMENT LIST & NOTES BLDG. W-4 ANNEX
41	4 C	34110	4	0	30-Oct-67	3716	E	ELECTRICAL - PLAN BLDG. W-4 ANNEX
41	4 C	35241	1	0	09-Jun-67	3676	AC	AIR CONDITIONING, ROOM 115, BLDG. W-4 - MECHANICAL & ELECTRICAL
41	4 C	35615	1	1	09-Apr-68	3807	AC	A/C COMPRESSOR CONTROLS & COOLING TOWER MODIFICATIONS, BLDG. W-4, ELECTRICAL & P
41	4 C	35616	2	1	09-Apr-68	3807	AC	A/C COMPRESSOR CONTROL & COOLING TOWER MODS., BLDG. W-4, PLANS, PNEUMATIC CONTRO
41	4 C	35728	1	0	27-Sep-67	3675	UN	MASS SPECTROMETER INSTALLATION, ROOM 123, BLDG. W-4
41	4 C	36325	1	0	27-Feb-68	0	UN	AIR LINE INSTALLATION, BLDG. W-4 & W-30
41	4 C	36897	1	0	28-Oct-68	4012	AC	VENTILATION MODIFICATION, ROOM 123, BLDG. W-4, PLAN
41	4 C	36898	2	0	28-Oct-68	4012	AC	VENTILATION MODIFICATION, ROOM 123, BLDG. W-4, DETAILS
41	4 C	37505	1	1	20-Mar-70	4070	M	LN2 SUPPLY SYSTEM MECH.-ELEC.-PLAN & DETAILS, BLDG. W-4, RM. 123
41	4 C	37506	2	1	20-Mar-70	4070	M	LN2 SUPPLY SYSTEM BLDG. W-4, RM. 123, MECH. SECTIONS & DETAILS
41	4 C	37661	1	3	29-Sep-69	4148	A	MODS. 1ST & 2ND FLOOR, BLDG. W-4, FIRST FLOOR ARCH. PLAN
41	4 C	37662	2	3	29-Aug-69	4148	A	SECOND FLOOR ARCH. PLAN
41	4 C	37663	3	3	29-Aug-69	4148	A	FIRST FLOOR ARCH. PLAN
41	4 C	37664	4	3	29-Sep-69	4148	A	SECOND FLOOR ARCH. PLAN
41	4 C	37665	5	3	29-Aug-69	4148	UN	MISC. DETAILS
41	4 C	37666	6	3	29-Aug-69	4148	AC	VENTILATION DETAILS
41	4 C	37667	7	3	29-Aug-69	4148	UN	ELEVATED WALK PLAN & DETAILS
41	4 C	37668	8	3	29-Aug-69	4148	E	FIRST FLOOR ELECT. PLAN
41	4 C	37669	9	3	29-Aug-69	4148	E	SECOND FLOOR ELECT. PLAN
41	4 C	38836	1	0	28-Jan-71	4576	M	UNIVERSAL TESTING MACHINE INSTALLATION, BLDG. W-4, RMS. 233-235 - MECH. - ELEC.
41	4 C	38842	1	1	21-Jan-92	4576	M	UNIVERSAL TESTING MACHINE INSTALLATION ARCH. MECH. ELEC. BLDG. W-4 RMS. 233 & 23
41	4 C	39645	1	0	22-Mar-71	4619	M	COOLING RM. NO. 236, BLDG. W-4 - MECHANICAL; PARTIAL PLAN, SECTION AND DETAILS
41	4 C	39646	2	0	22-Mar-71	4619	M	ELECTRICAL AND MECHANICAL PLAN EQUIPMENT & NOTES
41	4 C	39854	1	1	18-Jun-71	4675	S	DATA ACQUISITION SYSTEM, RM - 230, STRUCTUREAL; PLAN, NOTES, DETAILS
41	4 C	39855	2	1	18-Jun-71	4675	M	DATA ACQUISITION SYSTEM. RM-230, W-4 - MECHANICAL; PLAN, SECTIONS, DIAGRAMS, EQ
41	4 C	39856	3	1	21-Jan-92	4675	E	DATA ACQUISTION SYSTEM ROOM 230, BLDG. W-4 ELEC-POWER AND CABLE LAYOUT (AS-BU
41	4 C	39857	4	1	21-Jan-92	4675	F	DATA ACQUISTION SYSTEM, ROOM 230, BLDG. W-4 ELEC. SMOKE DETECTION SYSTEM (AS-B
41	4 C	40784	1	0	04-May-72	4858	UN	TEMPERATURE CONTROL ROOM 241, BUILDING W-4
41	4 C	40785	2	0	04-May-72	4858	UN	TEMPERATURE CONTROL ROOM 241, BUILDING W-4
41	4 C	41053	1	1	09-Nov-72	4944	M	H.P. COMPRESSOR INSTALLATION, MECH. & ELECT; PARTIAL PLAN, DETAILS, NOTES & EQU
41	4 C	41421	1	1	21-Jan-92	5000	E	HOIST MODS., RM. 240 & SHIPPING DOCK STRUCTURAL AND ELECTRICAL, BLDG. W-4 (
41	4 C	41732	1	1	10-Nov-87	7071	A	COOLING WATER MODIFICATIONS FIRST FLOOR PLAN, BLDG. W-4
41	4 C	41732	3	1	10-Nov-87	7071	UN	COOLING WATER MODIFICATION, EQUIP. ROOM LAYOUT & SCHEMATIC
41	4 C	41732	2	1	10-Nov-87	7071	A	COOLING WATER MODIFICATION, SECOND FLOOR PLAN
41	4 C	42576	1	0	09-Jul-74	5206	UN	SECURE AREA FOR COMMUNICATIONS LINK, BLDG. W-4 PLANS - SECTIONS & DETAILS
41	4 C	42577	2	0	09-Jul-74	5206	M	MECH; PLANS, NOTES, DETAIL & EQUIPMENT LIST
41	4 C	42578	4	0	09-Jul-74	5206	E	ELEC; BILL OF MATERIAL, NOTES, DETAIL, CONNECTION DIAGRAM & NAMEPLATES
41	4 C	42579	3	0	09-Jul-74	5206	E	ELECTRICAL PLANS
41	4 C	42652	4	1	21-Jan-92	5254	M	ROOM 236 MOD., BLDG. W-4, MECH; ELEVATIONS, NOTES, EQUIPMENT LIST (AS-BU
41	4 C	42652	1	1	21-Jan-92	5254	A	ROOM 236 MOD., BLDG. W-4, TA-41 LOCATION PLAN, ROOF & FLOOR PLAN, DOOR SCHED.

41	4	C	42652	3	0	10-Oct-74		5254	M	MECH; PARTIAL PLAN AND DETAILS
41	4	C	42652	5	0	10-Oct-74		5254	E	ELEC; PLAN, BILL OF MATERIAL, NAMEPLATES, NOTES AND SCOPE OF WORK
41	4	C	42652	2	0	10-Oct-74		5254	M	MECH; PARTIAL ROOF PLAN, DETAIL AND SECTION
41	4	C	42656	1	1	21-Jan-92		5257	E	MODIFY EXHAUST SYS., CONTROLS ELEC; PLANS BILL OF MAT. NOTES NAMEPLATES SCOPE &
41	4	C	42907	6	0	03-Feb-78		5563	M	FIRE PROTECTION IMPROVEMENTS, MECH; FIRST FLOOR PLAN
41	4	C	42907	3	1	03-Feb-78		5563	C	FIRE PROTECTION IMPROVEMENTS, CIVIL; SECTIONS AND DETAILS
41	4	C	42907	2	1	03-Feb-78		5563	C	FIRE PROTECTION IMPROVEMENTS, CIVIL; PLOT PLAN
41	4	C	42907	1	1	03-Feb-78		5563	T	FIRE PROTECTION IMPROVEMENTS, BLDG. W-4, TA-41. TITLE SHEET
41	4	C	42907	35	0	08-Dec-76	08-Dec-76	5563	A	FIRE PROTECTION IMPROVEMENTS, SECOND FLOOR PLAN
41	4	C	42907	34	0	08-Dec-76	08-Dec-76	5563	A	FIRE PROTECTION IMPROVEMENTS, FIRST FLOOR PLAN
41	4	C	42907	33	0	08-Dec-76	08-Dec-76	5563	A	FIRE PROTECTION IMPROVEMENTS, BASEMENT FLOOR PLAN
41	4	C	42907	16	1	03-Feb-78		5563	E	FIRE PROTECTION IMPROVEMENTS, ELEC; UNDERGROUND VAULT AND TUNNEL
41	4	C	42907	15	1	03-Feb-78		5563	E	FIRE PROTECTION IMPROVEMENTS, ELEC; SECOND FLOOR PLAN
41	4	C	42907	14	1	03-Feb-78		5563	E	FIRE PROTECTION IMPROVEMENTS, ELEC; FIRST FLOOR PLAN
41	4	C	42907	13	1	03-Feb-78		5563	E	FIRE PROTECTION IMPROVEMENTS, ELEC; BASEMENT PLAN
41	4	C	42907	12	1	03-Feb-78		5563	E	FIRE PROTECTION IMPROVEMENTS, ELEC; BLOCK DIAGRAMS
41	4	C	42907	7	0	03-Feb-78		5563	M	FIRE PROTECTION IMPROVEMENTS, MECH; SECOND FLOOR PLAN
41	4	C	42907	8	0	03-Feb-78		5563	M	FIRE PROTECTION IMPROVEMENTS, MECH; PLAN, SECTION, AND DETAILS
41	4	C	42907	9	0	03-Feb-78		5563	M	FIRE PROTECTION IMPROVEMENTS, MECH; TUNNEL PLAN, SECTIONS AND DETAILS
41	4	C	42907	11	1	03-Feb-78		5563	E	FIRE PROTECTION IMPROVE., ELEC; NAMEPLATES, BILL OF MATERAILS, AND NOTES
41	4	C	42907	10	0	03-Feb-78		5563	M	FIRE PROTECTION IMPROVEMENTS, MECH; SECTION AND DETAILS
41	4	C	42907	32	0	08-Dec-76	08-Dec-76	5563	C	FIRE PROTECTION IMPROVEMENTS PLOT PLAN BLDG. W-4, TA-41. TITLE I PACKAGE
41	4	C	42907	4	0	03-Feb-78		5563	C	FIRE PROTECTION IMPROVEMENTS, CIVIL; DETAILS
41	4	C	42907	5	0	03-Feb-78		5563	M	FIRE PROTECTION IMPROVEMENTS, MECH; BASEMENT PLAN
41	4	C	42986	1	0	13-May-76		5543	AC	AIR CONDITING ROOM 230. BLDG. W-4, TA-41. MECH - ELEC. PLAN, EQUIP. LIST AND NO
41	4	C	42986	2	0	13-May-76		5543	M	MECH - PLAN, SEC., AND DETAILS
41	4	C	43342	1	1	21-Jan-92		5708	UN	HALON SYSTEM INSTALLATION ROOMS #221 & #230, BLDG. W-4 (AS-BUILT)
41	4	C	43382	2	2	21-Jan-92		5741	M	GAS COMPRESSOR SYSEM MODS., BLDG. W-4, MECH; NOTES EQUIP. LIST & DETAIL (AS
41	4	C	43382	1	2	21-Jan-92		5741	M	GAS COMPRESSOR SYSTEM MODS., BLDG. W-4, TA-41 MECH; PARTIAL PLAN ROOMS 260 AND
41	4	C	43382	9	1	05-Jun-78		5741	E	ELECT; ELEMENTARY WIRING DIAGRAMS
41	4	C	43382	8	1	05-Jun-78		5741	E	ELECT; COMPRESSOR NO. 2 DETAIL WIRING DIAGRAM
41	4	C	43382	7	1	05-Jun-78		5741	E	ELECT; COMPRESSOR NO. 1 DETAIL WIRING DIAGRAM
41	4	C	43382	4	2	05-Jun-78		5741	E	ELECT; ELEVATIONS
41	4	C	43382	5	2	21-Jan-92		5741	E	ELECT; ELEVATORS (AS-BUILTS)
41	4	C	43382	3	2	21-Jan-92		5741	E	ELECT; FLOOR PLAN (AS-BUILT)
41	4	C	43382	6	1	05-Jun-78		5741	E	ELECT; SINGLE LINE DIAGRAMS
41	4	C	43382	10	1	05-Jun-78		5741	E	ELECT; BILL OF MATERIAL, NAMEPLATES AND NOTES
41	4	C	43403	1	0	18-Jan-78		5761	C	OFFICE SPACE CONVERSION, BLDG. W.4, TA-41 CIVIL; PLAN, SECTION NOTES
41	4	C	43403	3	0	18-Jan-78		5761	E	ELEC; PLAN
41	4	C	43403	2	0	18-Jan-78		5761	M	MECH; PLAN AND DETAIL
41	4	C	43554	9	0	26-Sep-78	11-Dec-79	5940	E	UPGRADE VENTILATION SYS, MAIN VAULT AREA 5 ELEC; OFFICE AND LAB AREA PLAN

41	4	C	43664	7	1	25-Apr-79		6157	E	ELECT; BILL OF MATERIAL, NOTES AND NAMEPLATE SCHEDULE
41	4	C	43664	4	1	25-Apr-79		6157	M	MECH; NOTES
41	4	C	43664	3	1	25-Apr-79		6157	M	MECH; PARTIAL ROOF PLAN, SECTION AND DETAIL
41	4	C	43664	2	1	25-Apr-79		6157	M	MECH; PARTIAL SECOND FLOOR PLANS
41	4	C	43664	1	1	25-Apr-79		6157	M	DARK ROOM AND SHOWER MODS MECH; PARTIAL FIRST FLOOR PLANS BLDG. W-4 TA-41
41	4	C	43664	5	1	25-Apr-79		6157	M	MECH; EQUIPMENT LIST
41	4	C	43664	6	1	25-Apr-79		6157	E	ELECT; ELECTRICAL PLANS
41	4	C	43721	8	0	31-Jan-80		6279	E	ELEC; PLANS
41	4	C	43721	7	0	31-Jan-80		6279	E	ELEC; BILL OF MATERIAL AND NOTES
41	4	C	43721	6	0	31-Jan-80		6279	M	MECH; EQUIPMENT LIST
41	4	C	43721	5	0	31-Jan-80		6279	M	MECH; NOTES
41	4	C	43721	4	1	21-Jan-92		6279	M	MECH; SECTIONS (AS-BUILTS)
41	4	C	43721	1	0	31-Jan-80		6279	C	OFFICE MODIFICATIONS SECOND FLOOR CIVIL; NOTES, LOCATION PLAN LEGEND AND DRAWIN
41	4	C	43721	3	0	31-Jan-80		6279	M	MECH; SECTIONS
41	4	C	43721	2	0	31-Jan-80		6279	C	CIVIL; PLAN, PARTIAL PLAN AND SECTION
41	4	C	43974	1	0			6804	UN	OFFICE MODS SECOND FLOOR BLDG. 4 TA-41
41	4	C	43974	2	0			6804	UN	OFFICE MODS SECOND FLOOR PLAN SECTION AND DETAILS
41	4	C	44011	2	0	21-Jan-92	28-May-82	6870	M	REPLACE CONDENSATE PIPING, MECH; PARTIAL FIRST FLOOR PLAN AND DETAILS
41	4	C	44011	3	0	02-Jun-82	28-Feb-82	6870	M	REPLACE CONDENSATE PIPING, MECH; NOTES
41	4	C	44011	1	1	01-Apr-03	16-Jul-90	6870	M	REPLACE CONDENSATE PIPING, MECH; PARTIAL BASEMENT FLOOR PLAN AND DETAILS
41	4	C	44065	112	1	27-May-82		4800	M	MECH; PLAN SECTION AND DETAILS
41	4	C	44065	114	1	27-May-82		4800	M	MECH; SECTIONS AND DETAILS
41	4	C	44065	113	1	27-May-82		4800	M	MECH; TUNNEL PLAN, SECTIONS AND DETAILS
41	4	C	44065	111	1	27-May-82		4800	M	MECH; SECOND FLOOR PLAN
41	4	C	44065	110	1	27-May-82		4800	M	MECH; FIRST FLOOR PLAN
41	4	C	44065	109	1	27-May-82		4800	M	MECH; BASEMENT PLAN
41	4	C	44065	108	1	27-May-82		4800	C	CIVIL; DETAILS
41	4	C	44065	106	2	27-May-82		4800	C	CIVIL; PLOT PLAN, BLDG. W-4, TA-41
41	4	C	44065	107	1	27-May-82		2800	C	CIVIL; SECTIONS AND DETAILS
41	4	C	44376	2	1	21-May-84	18-Apr-89	7371	G	EXHAUST SYSTEM MODIFICATIONS, GEN., SUBMITTALS NOTES, LIST AND LEGEND
41	4	C	44376	3	1	21-May-84	18-Apr-89	7371	M	EXHAUST SYSTEM MODIFICATIONS, MECH., ROOF PLAN AND DETAIL
41	4	C	44376	1	2	21-May-92	18-Apr-89	7371	T	EXHAUST SYSTEM MODIFICATIONS, TITLE SHEET AND INDEX TO DRAWINGS
41	4	C	44376	1	1	26-Nov-02	25-Jan-85	7371	T	EXHAUST SYSTEM MODIFICATIONS, TITLE SHEET AND INDEX TO DRAWINGS
41	4	C	44376	4	1	21-May-84	18-Apr-89	7371	M	EXHAUST SYSTEM MODIFICATIONS, MECH., NOTES AND DETAILS, ROOF PENETRATIONS
41	4	C	44520	21	0	20-May-85	20-May-85	8065	E	SAFEGUARDS & SECURITY UPGRADES, POWER & LIGHTING, ELEC., EXTERIOR LIGHTING LAYOUTS
41	4	C	44524	1	0	21-Jun-85	21-Jun-85	8067	S	SAFEGUARDS AND SECURITY UPGRADES, STRUCTURE HARDENING, STRUCT., PLANS, SECTIONS /
41	4	C	44545	1	0	31-Jul-85	29-Jul-85	8067	A	SAFEGUARDS & SECURITY UPGRADES, STRUCTURE HARDENING, ARCH., FIRST FLOOR DOORS
41	4	C	44545	3	0	31-Jul-85	29-Jul-85	8067	A	SAFEGUARDS & SECURITY UPGRADES, STRUCTURE HARDENING, ARCH., DOOR SCHEDULE & SPEC
41	4	C	44545	2	0	31-Jul-85	29-Jul-85	8067	A	SAFEGUARDS & SECURITY UPGRADES, STRUCTURE HARDENING, ARCH., SECOND FLOOR DOORS
41	4	C	44545	3	1	31-Jul-85	16-May-90	8067	A	SAFEGUARDS & SECURITY UPGRADES, STRUCTURE HARDENING, ARCH., DOOR SCHEDULE & SPEC
41	4	C	44782	32	3	20-Oct-87	10-Sep-87	7053	E	HVAC SYSTEM UPGRADE, ELEC; UTILITY TUNNEL POWER & DEMOLITION PLANS



41	4	C	44782	20	2	20-Oct-87	10-Sep-87	7053	M	HVAC SYSTEM UPGRADE, MECH; HVAC CONTROL DIAGRAM
41	4	C	44782	10	1	20-Oct-87	10-Sep-87	7053	M	HVAC SYSTEM UPGRADE, MECH; 2ND FLOOR HVAC PLAN
41	4	C	44782	5	3	20-Oct-87	10-Sep-87	7053	S	HVAC SYSTEM UPGRADE, STRUCT; EQUIPMENT PADS AND FOUNDATIONS
41	4	C	44782	26	3	21-Jan-92	07-Jan-88	7053	M	HVAC SYSTEM UPGRADE, MECH; EQUIPMENT LIST
41	4	C	44782	34	3	20-Oct-87	10-Sep-87	7053	E	HVAC SYSTEM UPGRADE, ELEC; PARTIAL PLANS, SECTIONS AND DETAILS
41	4	C	44782	15	2	20-Oct-87	10-Sep-87	7053	M	HVAC SYSTEM UPGRADE, MECH; 2ND FLOOR DEMOLITION PLAN
41	4	C	44782	18	2	20-Oct-87	10-Sep-87	7053	M	HVAC SYSTEM UPGRADE, MECH; MECHANICAL ROOMS-DEMOLITION PLANS
41	4	C	44782	17	1	20-Oct-87	10-Sep-87	7053	M	HVAC SYSTEM UPGRADE, MECH; 1ST FLOOR DEMOLITION PLAN-UTILTY TUNNEL
41	4	C	44782	16	2	20-Oct-87	10-Sep-87	7053	M	HVAC SYSTEM UPGRADE, MECH; 2ND FLOOR DEMOLITION PLAN
41	4	C	44782	19	2	20-Oct-87	10-Sep-87	7053	M	HVAC SYSTEM UPGRADE, MECH; HVAC CONTROL DIAGRAM
41	4	C	44782	22	2	20-Oct-87	10-Sep-87	7053	M	HVAC SYSTEM UPGRADE, MECH; GENERAL NOTES
41	4	C	44782	24	2	21-Jan-92	07-Jan-80	7053	M	HVAC SYSTEM UPGRADE, MECH; EQUIPMENT LIST
41	4	C	44782	12	2	20-Oct-87	10-Sep-87	7053	M	HVAC SYSTEM UPGRADE, MECH; MECHANICAL ROOMS
41	4	C	44782	11	2	20-Oct-87	10-Sep-87	7053	M	HVAC SYSTEM UPGRADE, MECH; 1ST FLOOR HVAC PLAN
41	4	C	44782	9	2	20-Oct-87	10-Sep-87	7053	M	HVAC SYSTEM UPGRADE, MECH; 2ND FLOOR HVAC PLAN
41	4	C	44782	8	1	20-Oct-87	10-Sep-87	7053	S	HVAC SYSTEM UPGRADE, STRUCT; AIR HANDLING UNIT #3 SUPPORT FRAME
41	4	C	44782	7	0	20-Oct-87	10-Sep-87	7053	S	HVAC SYSTEM UPGRADE, STRUCT; LOUVER AND GLASS BLOCK INSTALLATION
41	4	C	44782	6	1	20-Oct-87	10-Sep-87	7053	S	HVAC SYSTEM UPGRADE, STRUCT; SECTION AND DETAILS
41	4	C	44782	4	0	20-Oct-87	10-Sep-87	7053	S	HVAC SYSTEM UPGRADE, STRUCT; DEMOLITION PLAN
41	4	C	44782	3	1	20-Oct-87	10-Sep-87	7053	S	HVAC SYSTEM UPGRADE, STRUCT; GENERAL NOTES
41	4	C	44782	2	2	20-Oct-87	10-Sep-87	7053	G	HVAC SYSTEM UPGRADE, GEN; SUBMITTALS
41	4	C	44782	1	4	20-Oct-87	10-Sep-87	7053	T	HVAC SYSTEM UPGRADE, BLDG. W4, TITLE SHEET (AS-BUILT)
41	4	C	44782	33	1	20-Oct-87	10-Sep-87	7053	E	HVAC SYSTEM UPGRADE, ELEC; INTERCONNECT & WIRING DIAGRAMS
41	4	C	44782	31	3	20-Oct-87	10-Sep-87	7053	E	HVAC SYS. UPGRADE, ELEC; MECH. ROOMS 128 & 227 & CHILLER ROOM 130 POWER PLANS
41	4	C	44782	30	1	20-Oct-87	10-Sep-87	7053	E	HVAC SYSTEM UPGRADE, ELEC; DEMOLITION PLAN
41	4	C	44782	29	1	20-Oct-87	10-Sep-87	7053	E	HVAC SYSTEM UPGRADE, GEN. NOTES, ELEC. EQUIP. LIST, NAME PLATE SCHED. & LEGEND
41	4	C	44782	28	4	06-Jul-88	07-Jan-88	7053	M	HVAC SYSTEM UPGRADE, MECH; EQUIPMENT LIST
41	4	C	44782	27	3	21-Jan-92	07-Jan-88	7053	M	HVAC SYSTEM UPGRADE, MECH; EQUIPMENT LIST
41	4	C	44782	25	2	19-Feb-88	07-Jan-88	7053	M	HVAC SYSTEM UPGRADE, MECH; EQUIPMENT LIST
41	4	C	44782	14	4	20-Oct-87	10-Sep-87	7053	M	HVAC SYSTEM UPGRADE, MECH; HVAC DETAILS
41	4	C	44782	13	3	20-Oct-87	10-Sep-87	7053	M	HVAC SYSTEM UPGRADE, MECH; HVAC SECTIONS AND DETAIL
41	4	C	44782	23	1	20-Oct-87	10-Sep-87	7053	M	HVAC SYSTEM UPGRADE, MECH; GENERAL NOTES
41	4	C	44782	21	2	20-Oct-87	10-Sep-87	7053	M	HVAC SYSTEM UPGRADE, MECH; HVAC CONTROL DIAGRAM
41	4	C	44971	1	0	02-Apr-86	04-Mar-86	8464	E	PINCH WELDER INSTALL. ELEC; BILL OF MATERIAL, NOTES, LEG. SCOPE OF WORK LOC. PLA
41	4	C	44994	1	0	26-Mar-86	13-Mar-86	8510	M	DRAINAGE DIVERSION, MECH., FLOOR PLAN, PIPING ISOMETRIC, SECTION & NOTES
41	4	C	44994	4	0	26-Mar-86	13-Mar-86	8510	G	DRAINAGE DIVERSION, GEN., SUBMITTAL SHEET
41	4	C	44994	2	0	26-Mar-86	13-Mar-86	8510	M	DRAINAGE DIVERSION, MECH., GENERAL NOTES & EQUIPMENT LIST
41	4	C	44994	3	0	26-Mar-86	13-Mar-86	8510	E	DRAINAGE DIVERSION, ELEC., PARTIAL PLAN, NOTES, LEGEND & EQUIPMENT LIST, NAMEPLATE SC
41	4	C	45701	2	1	21-Jan-92	11-Jul-89	10174	M	REPLACE STEAM BOILERS, MECH; SECTIONS
41	4	C	45701	3	0	27-Jul-89	11-Jul-89	10174	M	REPLACE STEAM BOILERS, MECH; EQUIPMENT LIST
41	4	C	45701	4	0	27-Jul-89	11-Jul-89	10174	M	REPLACE STEAM BOILERS, MECH; NOTES

41	4	C	45701	1	1		21-Jan-92	11-Jul-89	10174	M	REPLACE STEAM BOILERS, MECH; FLOOR PLAN, DETAIL, SCHEDULE & LEGEND, IRI GAS TRAIN DET/
41	4	C	45854	79	0		17-Jan-92	17-Jan-91	10594	E	AS-BUILT PROGRAM BUILDING, ELECT; LIGHTING & ELECTRICAL EQUIP. PLAN WEST ICE HOUSE WI
41	4	C	45854	80	0		17-Jan-92	17-Jan-91	10594	E	AS-BUILT PROGRAM BUILDING, ELECT; POWER PLAN SOUTH TUNNEL
41	4	C	45854	82	0		17-Jan-92	17-Jan-91	10594	E	AS-BUILT PROGRAM BUILDING, ELECT; POWER PLAN EAST OFFICE WING
41	4	C	45854	81	0		17-Jan-92	17-Jan-91	10594	E	AS-BUILT PROGRAM BUILDING, ELECT; POWER PLAN WEST OFFICE WING
41	4	C	45854	84	0		17-Jan-92	17-Jan-91	10594	E	AS-BUILT PROGRAM BUILDING, ELECT; POWER PLAN UTILITY TUNNEL
41	4	C	45854	28	0		17-Jan-92	17-Jan-91	10594	M	AS-BUILT PROGRAM BUILDING, MECH; SECOND FLOOR PLAN COMPOSITE OF PIPING
41	4	C	45854	62	0		17-Jan-92	17-Jan-91	10594	E	AS-BUILT PROGRAM BUILDING, ELECT; PANEL SCHEDULES LP-3 AND LP-4
41	4	C	45854	61	0		17-Jan-92	17-Jan-91	10594	E	AS-BUILT PROGRAM BUILDING, ELECT; PANEL SCHEDULES LP-1 AND LP-2
41	4	C	45854	59	0		17-Jan-92	17-Jan-91	10594	E	AS-BUILT PROGRAM BUILDING, ELECT; PANEL SCHEDULES PP-5, PP-6 AND PP-7
41	4	C	45854	55	0		17-Jan-92	17-Jan-91	10594	E	AS-BUILT PROGRAM BUILDING, ELECT; PANEL SCHEDULES PP-B AND PP-C
41	4	C	45854	51	0		17-Jan-92	17-Jan-91	10594	E	AS-BUILT PROGRAM BUILDING, ELEC; MASTER ONE LINE DIAGRAM PP-5, PP-1 PP-E
41	4	C	45854	50	0		17-Jan-92	17-Jan-91	10594	E	AS-BUILT PROGRAM BUILDING, ELEC; MASTER ONE LINE DIAGRAM SUS-A & PP-C
41	4	C	45854	49	0		17-Jan-92	17-Jan-91	10594	E	AS-BUILT PROGRAM BUILDING, ELECT; RISER DIAGRAM
41	4	C	45854	45	0		17-Jan-92	17-Jan-91	10594	M	AS-BUILT PROGRAM BUILDING, MECH; FIRST FLOOR PLAN COOLING WATER
41	4	C	45854	44	0		17-Jan-92	17-Jan-91	10594	M	AS-BUILT PROGRAM BUILDING, MECH; AIR & GAS ISOMETRIC
41	4	C	45854	76	0		17-Jan-92	17-Jan-91	10594	E	AS-BUILT PROGRAM BUILDING, ELECT; LIGHTING & ELECTRICAL EQUIP. PLAN WEST OFFICE WING
41	4	C	45854	75	0		17-Jan-92	17-Jan-91	10594	E	AS-BUILT PROGRAM BUILDING, ELECT; LIGHTING & ELECTRICAL EQUIP. PLAN UTILITY TUNNEL
41	4	C	45854	74	0		17-Jan-92	17-Jan-91	10594	M	AS-BUILT PROGRAM BUILDING, ELECT; LIGHTING & ELECTRICAL EQUIP. ROOM 127/MECH. ROOM AF
41	4	C	45854	73	0		17-Jan-92	17-Jan-91	10594	E	AS-BUILT PROGRAM BUILDING, ELECT; LIGHTING & ELECTRICAL EQUIP. PLAN EAST OFFICE WING
41	4	C	45854	71	0		17-Jan-92	17-Jan-91	10594	E	AS-BUILT PROGRAM BUILDING, ELEC; LIGHTING AND ELECTRICAL EQUIP. PLAN SOUTH TUNNEL
41	4	C	45854	69	0		17-Jan-92	17-Jan-91	10594	E	AS-BUILT PROGRAM BUILDING, ELECT; PANEL SCHEDULES LP-21 AND LP-22
41	4	C	45854	68	0		17-Jan-92	17-Jan-91	10594	E	AS-BUILT PROGRAM BUILDING, ELEC; PANEL SCHEDULES LP-19 & LP-20
41	4	C	45854	67	0		17-Jan-92	17-Jan-91	10594	E	AS-BUILT PROGRAM BUILDING, ELECT; PANEL SCHEDULES LP-16, LP-17 AND LP-18
41	4	C	45854	66	0		17-Jan-92	17-Jan-91	10594	E	AS-BUILT PROGRAM BUILDING, ELECT; PANEL SCHEDULES LP-13, LP-14 AND LP-15
41	4	C	45854	64	0		17-Jan-92	17-Jan-91	10594	E	AS-BUILT PROGRAM BUILDING, ELECT; PANEL SCHEDULES LP-7, LP-8 AND LP-9
41	4	C	45854	63	0		17-Jan-92	17-Jan-91	10594	E	AS-BUILT PROGRAM BUILDING, ELECT; PANEL SCHEDULES LP-5, LP-6 AND LP-6A
41	4	C	45854	89	0		17-Jan-92	17-Jan-91	10594	F	AS-BUILT PROGRAM BUILDING, ELECT; BASEMENT, FIRE PROTECTION IMPROVEMENTS & TELEPHC
41	4	C	45854	88	0		17-Jan-92	17-Jan-91	10594	E	AS-BUILT PROGRAM BUILDING, ELECT; POWER PLAN, WEST ICE HOUSE SECOND FLOOR
41	4	C	45854	87	0		17-Jan-92	17-Jan-91	10594	E	AS-BUILT PROGRAM BUILDING, ELECT; POWER PLAN EAST ICE HOUSE WING
41	4	C	45854	86	0		17-Jan-92	17-Jan-91	10594	E	AS-BUILT PROGRAM BUILDING, ELECT; POWER PLAN EAST OFFICE WING
41	4	C	45854	9	0		17-Jan-92	17-Jan-91	10594	G	AS-BUILT PROGRAM BUILDING, GEN; GENERAL LEGEND SYMBOLS
41	4	C	45854	8	0		17-Jan-92	17-Jan-91	10594	T	AS-BUILT PROGRAM BUILDING, BUILDING TITLE SHEET
41	4	C	45854	43	0		17-Jan-92	17-Jan-91	10594	M	AS-BUILT PROGRAM BUILDING, MECH; FIRST FLOOR PLAN GAS PIPING PLAN
41	4	C	45854	41	0		17-Jan-92	17-Jan-91	10594	M	AS-BUILT PROGRAM BUILDING, MECH; FIRST FLOOR PLAN AIR PIPING PLAN
41	4	C	45854	39	0		17-Jan-92	17-Jan-91	10594	M	AS-BUILT PROGRAM BUILDING, MECH; HOT & COLD WATER ISOMETRIC
41	4	C	45854	36	0		17-Jan-92	17-Jan-91	10594	M	AS-BUILT PROGRAM BUILDING, MECH; FIRST FLOOR PLAN HOT WATER PIPING
41	4	C	45854	33	0		17-Jan-92	17-Jan-91	10594	M	AS-BUILT PROGRAM BUILDING, MECH; ISOMETRIC STORM DRAIN & SANITARY SEWER
41	4	C	45854	31	0		17-Jan-92	17-Jan-91	10594	M	AS-BUILT PROGRAM BUILDING, MECH; SECOND FLOOR PLAN SANITARY SEWER/DRAIN PIPING
41	4	C	45854	30	0		17-Jan-92	17-Jan-91	10594	M	AS-BUILT PROGRAM BUILDING, MECH; FIRST FLOOR PLAN SANITARY SEWER/DRAIN PIPING
41	4	C	45854	5	0		17-Jan-92	17-Jan-91	10594	T	AS-BUILT PROGRAM BUILDING, BUILDING TITLE SHEET

41	4	C	45854	3	0	17-Jan-92	17-Jan-91	10594	T	AS-BUILT PROGRAM BUILDING, BUILDING TITLE SHEET
41	4	C	45854	2	0	17-Jan-92	17-Jan-91	10594	T	AS-BUILT PROGRAM BUILDING, TABLE OF CONTENTS
41	4	C	45854	1	0	17-Jan-92	17-Jan-91	10594	T	AS-BUILT PROGRAM BUILDING, TABLE OF CONTENTS TO DRAWING INDEXES
41	4	C	45854	24	0	17-Jan-92	17-Jan-91	10594	M	AS-BUILT PROGRAM BUILDING, MECH; HVAC - MECHANICAL ROOM LAYOUTS
41	4	C	45854	23	0	17-Jan-92	17-Jan-91	10594	M	AS-BUILT PROGRAM BUILDING, MECH; HVAC PLAN-NORTH UTILITY TUNNEL
41	4	C	45854	22	0	17-Jan-92	17-Jan-91	10594	M	AS-BUILT PROGRAM BUILDING, MECH; HVAC 2ND FLOOR PLAN-EAST ICE HOUSE WING
41	4	C	45854	21	0	17-Jan-92	17-Jan-91	10594	M	AS-BUILT PROGRAM BUILDING, MECH; HVAC 2ND FLOOR PLAN-WEST ICE HOUSE WING
41	4	C	45854	18	0	17-Jan-92	17-Jan-91	10594	M	AS-BUILT PROGRAM BUILDING, MECH; HVAC SECOND FLOOR PLAN, WEST OFFICE WING
41	4	C	45854	16	0	17-Jan-92	17-Jan-91	10594	M	AS-BUILT PROGRAM BUILDING, MECH; HVAC FRIST FLOOR PLAN, WEST OFFICE WING
41	4	C	45854	14	0	17-Jan-92	17-Jan-91	10594	A	AS-BUILT PROGRAM BUILDING, ARCH; FIRST FLOOR PLAN
41	4	C	45854	13	0	17-Jan-92	17-Jan-91	10594	A	AS-BUILT PROGRAM BUILDING, ARCH; BASEMENT FLOOR PLAN
41	4	C	45854	12	0	17-Jan-92	17-Jan-91	10594	C	AS-BUILT PROGRAM BUILDING, CIVIL; UTILITY PLAN
41	4	C	45854	10	0	17-Jan-92	17-Jan-91	10594	C	AS-BUILT PROGRAM BUILDING, CIVIL; STRUCTURE LOCATION PLAN
41	4	C	45854	53	0	17-Jan-92	17-Jan-91	10594	E	AS-BUILT PROGRAM BUILDING, ELEC; MASTER ONE LINE DIAGRAM, PP-A & PP-9
41	4	C	45854	58	0	17-Jan-92	17-Jan-91	10594	E	AS-BUILT PROGRAM BUILDING, ELECT; PANEL SCHEDULES PP-3, PP-4, LP-28 & LP-29
41	4	C	45854	70	0	17-Jan-92	17-Jan-91	10594	E	AS-BUILT PROGRAM BUILDING, ELECT; PANEL SCHEDULES LP-13A AND LP-25
41	4	C	45854	90	0	17-Jan-92	17-Jan-91	10594	F	AS-BUILT PROGRAM BUILDING, ELECT; FIRST FLOOR, FIRE PROTECTION IMPROVEMENTS AND TEL
41	4	C	45854	25	0	17-Jan-92	17-Jan-91	10594	M	AS-BUILT PROGRAM BUILDING, MECH; ROOF PLAN
41	4	C	45854	65	0	07-May-02	17-Jan-91	10594	E	AS-BUILT PROGRAM BUILDING, ELECT; PANEL SCHEDULES LP-10, LP-11 AND LP-12
41	4	C	45854	56	0	17-Jan-92	17-Jan-91	10594	E	AS-BUILT PROGRAM BUILDING, ELECT; PANEL SCHEDULES PP-D AND PP-E
41	4	C	45854	34	0	17-Jan-92	17-Jan-91	10594	AC	AS-BUILT PROGRAM BUILDING, MECH; ISOMETRIC VENT
41	4	C	45854	91	0	17-Jan-92	17-Jan-91	10594	F	AS-BUILT PROGRAM BUILDING, ELECT; SECOND FLOOR, FIRE PROTECTION IMPROVEMENTS AND T
41	4	C	45854	32	0	17-Jan-92	17-Jan-91	10594	M	AS-BUILT PROGRAM BUILDING, MECH; ROOF DRAIN PLAN
41	4	C	45854	27	0	17-Jan-92	17-Jan-91	10594	M	AS-BUILT PROGRAM BUILDING, MECH; FIRST FLOOR PLAN COMPOSITE OF PIPING
41	4	C	45854	19	0	17-Jan-92	17-Jan-91	10594	M	AS-BUILT PROGRAM BUILDING, MECH; HVAC SECOND FLOOR PLAN, EAST OFFICE WING
41	4	C	45854	4	0	17-Jan-92	17-Jan-91	10594	T	AS-BUILT PROGRAM BUILDING, BUILDING TITLE SHEET
41	4	C	45854	7	0	17-Jan-92	17-Jan-91	10594	T	AS-BUILT PROGRAM BUILDING, BUILDING TITLE SHEET
41	4	C	45854	40	0	17-Jan-92	17-Jan-91	10594	M	AS-BUILT PROGRAM BUILDING, MECH; BASEMENT FLOOR PLAN AIR PIPING
41	4	C	45854	35	0	17-Jan-92	17-Jan-91	10594	M	AS-BUILT PROGRAM BUILDING, MECH; BASEMENT FLOOR PLAN HOT WATER PIPING
41	4	C	45854	20	0	17-Jan-92	17-Jan-91	10594	M	AS-BUILT PROGRAM BUILDING, MECH; HVAC FLOOR PLAN-ROOM 127/MECH. ROOM AREA
41	4	C	45854	77	0	17-Jan-92	17-Jan-91	10594	E	AS-BUILT PROGRAM BUILDING, ELECT; LIGHTING & ELECTRICAL EQUIP. PLAN EAST OFFICE WING
41	4	C	45854	17	0	17-Jan-92	17-Jan-91	10594	M	AS-BUILT PROGRAM BUILDING, MECH; HVAC FRIST FLOOR PLAN, EAST OFFICE WING
41	4	C	45854	15	0	17-Jan-92	17-Jan-91	10594	A	AS-BUILT PROGRAM BUILDING, ARCH; SECOND FLOOR PLAN
41	4	C	45854	11	0	17-Jan-92	17-Jan-91	10594	C	AS-BUILT PROGRAM BUILDING, CIVIL; SITE PLAN
41	4	C	45854	78	0	17-Jan-92	17-Jan-91	10594	E	AS-BUILT PROGRAM BUILDING, ELEC; LIGHTING & ELECTRICAL EQUIP. PLAN EAST ICE HOUSE WING
41	4	C	45854	60	0	17-Jan-92	17-Jan-91	10594	E	AS-BUILT PROGRAM BUILDING, ELECT; PANEL SCHEDULES PP-8, PP-9 AND PP-10
41	4	C	45854	52	0	17-Jan-92	17-Jan-91	10594	E	AS-BUILT PROGRAM BUILDING, ELEC; MASTER ONE LINE DIAGRAM PP-D, MCC-A AND MISC. PANELS
41	4	C	45854	47	0	17-Jan-92	17-Jan-91	10594	M	AS-BUILT PROGRAM BUILDING, MECH; ROOM LAYOUTS COOLING WATER
41	4	C	45854	42	0	17-Jan-92	17-Jan-91	10594	M	AS-BUILT PROGRAM BUILDING, MECH; BASEMENT FLOOR GAS PIPING PLAN
41	4	C	45854	37	0	17-Jan-92	17-Jan-91	10594	M	AS-BUILT PROGRAM BUILDING, MECH; BASEMENT FLOOR PLAN COLD WATER PIPING
41	4	C	45854	85	0	17-Jan-92	17-Jan-91	10594	E	AS-BUILT PROGRAM BUILDING, ELECT; POWER PLAN WEST OFFICE WING

41	4	PL	3735	2	0	09-Feb-98	06-Apr-78	5783	C	NEW TRITIUM FACILITY BLDG. W-4 TA-41, W-SITE, PLOT PLAN, LOCATION PLAN
41	4	PL	3735	1	0	05-Jan-78		5783	T	NEW TRITIUM FACILITY BLDG. W-4 TA-41, TITLE SHEET, INDEX, SITE LOCATION
41	4	PL	3735	2	0	05-Jan-78		5783	C	NEW TRITIUM FACILITY, W-SITE PLOT PLAN
41	4	PL	3735	3	0	05-Jan-78		5783	A	NEW TRITUM FACILITY, PLANS FIRST AND SECOND FLOORS SECT. 'A-A'
41	4	PL	3735	4	0	05-Jan-78		5783	A	NEW TRITIUM FACILITY, PROCESS EQUIPMENT
41	4	PL	3735	1	0	09-Feb-98	06-Apr-78	5783	T	NEW TRITIUM FACILITY BLDG. W-4 TA-41, INDEX TO DRAWINGS
41	4	PL	3735	3	0	09-Feb-98	06-Apr-78	5783	A	NEW TRITIUM FACILITY BLDG., PLANS FIRST AND SECOND FLOORS, SECTION A-A
41	4	PL	3735	5	0	09-Feb-98	06-Apr-78	5783	M	NEW TRITIUM FACILITY BLDG., AIR PATTERN SCHEMATIC, RECOVERY ROOM
41	4	PL	3735	6	0	05-Jan-78		5783	M	NEW TRITIUM FACILITY, FLOW SCHEMATIC
41	4	PL	3735	7	0	08-Jan-78		5783	M	NEW TRITIUM FACILITY, FLOW SCHEMATIC
41	4	R	1960	1	2	11-Jan-63		0	F	FIRE ALARM EQUIPMENT, BLDG. W-4, FIRST FLOOR PLAN
41	4	R	1961	2	0	11-Jan-63		0	F	FIRE ALARM EQUIPMENT, BLDG. W-4, SECOND FLOOR PLAN
41	4	R	3139	1	3	06-Mar-89	02-Feb-90	7556	A	LABORATORY BUILDING, RECORD DRAWING FLOOR PLAN BASEMENT FLOOR PLAN
41	4	R	3140	2	6	06-Mar-89	02-Feb-90	7556	A	LABORATORY BUILDING, RECORD DRAWING FLOOR PLAN FIRST FLOOR PLAN
41	4	R	3141	3	9	23-Apr-90	06-Jul-84	7556	A	LABORATORY BUILDING, RECORD DRAWING FLOOR PLAN SECOND FLOOR PLAN
41	4	R	3836	1	0	28-Sep-66	29-Sep-83	3546	A	EQUIPMENT SURVEILLANCE SYSTEMS, FIRST FLOOR PLAN
41	4	R	4392	22	0	25-Aug-72	25-Aug-72	4861	F	FMEA FIRE PROTECTION SURVEY
41	4	SK	1525	1	1	05-Dec-00	29-Jul-53	1281	M	REVISION OF COMBUSTION AIR SUPPLY, RM. A-7, ELEVATION AND DETAILS, LOCATION PLAN
41	4	SK	1603	1	0		02-Jul-53	7577	A	PARTITION MODIFICATIONS ROOMS 224 & 226 ARCH PLAN & DETAILS
41	4	SK	2091	1	0	03-Nov-97	10-Mar-52	1088	C	PARKING LOT ALTERATIONS, W-SITE
41	4	SK	2610	1	0	10-Sep-97	17-Sep-54	1641	A	OFFICE AREA MODIFICATIONS, PLAN & DETAILS, BLDG. W-4
41	4	SK	7267	1	0	03-Mar-98	21-Mar-85	8067	A	SECURITY ENHANCEMENTS STRUCTURE HARDENING, ARCH, DOOR SCHEDULE/SPECS.
41	4	SK	7317	1	0	16-Aug-01	14-Jan-89		F	SPRINKLER MODIFICATIONS
41	4	SK	7629	1	0	16-Aug-01	26-Oct-88		F	VAULT SPRINKLER MODIFICATIONS
41	4	SK	7648	1	1	16-Oct-89		9567	UN	SAFEGUARDS & SECURITY UPGRADE, PHASE II; VAULT UPGRADE RM. 237, BLDG. W-4, SRUCT
41	4	SK	7648	2	0	08-Feb-89		9567	S	STRUCTURAL DETAILS
41	4	SK	7648	4	0	08-Feb-89		9567	S	STRUCTURAL DETAILS
41	4	SK	7648	5	0	08-Feb-89		9567	S	STRUCTURAL DETAILS
41	4	SK	7648	3	0	08-Feb-89		9567	S	STRUCTURAL DETAILS
41	4	SK	7657	1	0	08-Mar-89		7053	F	SPRINKLER MODS., BLDG. 4, ROOM 236
41	4	SK	7893	1	0	20-Aug-94		14220	E	SUBSTATION REPLACEMENT, ELEC; SUBSTATION TA-41-4 'SUS-A' ONE LINE DIAGRAM
41	4	SK	7893	2	0	20-Aug-94		14220	E	ELEC; SUBSTATION TA-41-4 'SUS-A' ONE LINE DIAGRAM
41	4	SK	7893	3	0	20-Aug-94		14220	E	ELEC; SUBSTATION TA-41-4 'SUS-A' DEMOLITION PLAN
41	4	SK	7920	1	0	01-May-97	20-Aug-93	14220	T	TITLE SHEET. SUBSTATION REPLACEMENT.
41	4	SK	7920	2	0	01-May-97	20-Aug-93	14220	E	ELEC. SUS-A ELECTRICAL NOTES + SPECIAL NOTES. SUBSTATION REPLACEMENT.
41	4	SK	7920	3	0	01-May-97	20-Aug-93	14220	E	ELEC. SUS-A ONE-LINE DIAGRAM. SUBSTATION REPLACEMENT.
41	4	SK	7920	4	0	01-May-97	20-Aug-93	14220	E	ELEC. SUS-A ONE-LINE DIAGRAM. SUBSTATION REPLACEMENT.
41	4	SK	7920	5	0	01-May-97	20-Aug-93	14220	E	ELEC. SUS-A ONE-LINE DIAGRAM. SUBSTATION REPLACEMENT.
41	4	SK	7920	6	0	01-May-97	20-Aug-93	14220	E	ELEC. SUS-A ONE-LINE DIAGRAM. SUBSTATION REPLACEMENT.
41	4	SK	7920	7	0	01-May-97	20-Aug-93	14220	E	ELEC. SUS-A ONE-LINE DIAGRAM. SUBSTATION REPLACEMENT.
41	4	SK	7920	8	0	01-May-97	20-Aug-93	14220	E	ELEC. SUS-A ONE-LINE DIAGRAM. SUBSTATION REPLACEMENT.

41	4	SK	7920	9	0	01-May-97	20-Aug-93	14220	E	ELEC. SUS-A DEMOLITION PLAN AND ELEVATION. SUBSTATION REPLACEMENT.
41	4	SK	7920	10	0	01-May-97	20-Aug-93	14220	E	ELEC. SUS-A INSTALLATION PLAN AND NAMEPLATE SCHEDULE. SUBSTATION REPLACEMENT.
41	4	SK	7920	11	0	01-May-97	20-Aug-93	14220	E	ELEC. FIRST FLOOR PLAN EQUIPMENT LOCATION. SUBSTATION REPLACEMENT.
41	4	SK	7920	12	0	01-May-97	20-Aug-93	14220	E	ELEC. SECOND FLOOR PLAN EQUIPMENT LOCATION. SUBSTATION REPLACEMENT.
41	4	SK	7920	13	0	01-May-97	20-Aug-93	14220	E	SUBSTATION TA-18-142 'SUS-A' CIRCUIT BREAKER SETTINGS, ELEVATION & GROUNDING.
41	4	SK	52208	1	0	16-Aug-01	24-May-99	019387	F	TA-41-4 MODIFICATIONS FIRE PROTECTION

**REPORT FOR: DRAWINGS**

TA	BLDG	PREFIX	DRAWNUM	PAGE	REV	DSHEET	LOG_DATE	DOC_DATE	PROJID	DISC	TITLE
41	6	AB	804	1	0		29-JUL-97	10-JAN-97	16523	A	ARCH. RECORD FLOOR PLAN. COVERED PASSAGEWAY.
41	6	C	15141	30	2		08-JUN-53		442	UN	PLANS, ELEVATIONS & DETAILS BLDG. W-6
41	6	C	26292	1	0		27-FEB-63		2871	A	PASSAGEWAY ALTERATIONS, BLDG. W-6, ARCHITECTURAL - DETAILS
41	6	C	44544	6	0		15-AUG-85	23-JUL-85	8067	E	SAFEGUARDS & SECURITY UPGRADES STRUCTURE HARDENING, MONITORING STATION, ELEC., SCOPE OF WORK, NOTES, NAMEPLATE SCHEDULE
41	6	C	44544	7	1		15-AUG-85	23-JUL-85	8067	E	SAFEGUARDS & SECURITY UPGRADES STRUCTURE HARDENING, MONITORING STATION, ELEC., SITE PLAN
41	6	C	44544	10	1		15-AUG-85	23-JUL-85	8067	E	SAFEGUARDS & SECURITY UPGRADES STRUCTURE HARDENING, MONITORING STATION, ELEC., BILL OF MATERIALS
41	6	C	44544	3	0		15-AUG-85	23-JUL-85	8067	M	SAFEGUARDS & SECURITY UPGRADES STRUCTURE HARDENING, MONITORING STATION, MECH., NOTES & PLAN
41	6	C	44544	5	1		15-AUG-85	23-JUL-85	8067	S	SAFEGUARDS & SECURITY UPGRADES STRUCTURE HARDENING, MONITORING STATION, STRUCT., ROOF FRAMING PLAN, SECTIONS, & DETAILS
41	6	C	44544	8	1		15-AUG-85	23-JUL-85	8067	E	SAFEGUARDS & SECURITY UPGRADES STRUCTURE HARDENING, MONITORING STATION, ELEC., MONITORING GUARD STATION POWER LAYOUTS
41	6	C	44544	2	1		15-AUG-85	23-JUL-85	8067	G	SAFEGUARDS & SECURITY UPGRADES STRUCTURE HARDENING, MONITORING STATION, GEN., SUBMITTALS
41	6	C	44544	4	1		15-AUG-85	23-JUL-85	8067	S	SAFEGUARDS & SECURITY UPGRADES STRUCTURE HARDENING, MONITORING STATION, STRUCT., FLOOR PLANS, ELEVATIONS, & DETAILS
41	6	C	44544	1	1		15-AUG-85	23-JUL-85	8067	T	SAFEGUARDS & SECURITY UPGRADES STRUCTURE HARDENING, MONITORING STATION, TITLE SHEET, INDEX TO DRAWINGS, LOCATION PLAN
41	6	C	44544	9	1		15-AUG-85	23-JUL-85	8067	E	SAFEGUARDS & SECURITY UPGRADES STRUCTURE HARDENING, MONITORING STATION, ELEC., PANEL SCHEDULES
41	6	C	44544	7	1		15-AUG-85	23-JUL-85	8067	C	SAFEGUARDS & SECURITY UPGRADES STRUCTURE HARDENING, MONITORING STATION, ELEC., SITE PLAN
41	6	R	3143	1	3		08-OCT-64	06-MAR-84	0	A	FLOOR PLAN, PASSAGEWAY W-6, COVERED PASSAGEWAY

**REPORT FOR: DRAWINGS**

TA	BLDG	PREFIX	DRAWNUM	PAGE	REV	DSHEET	LOG DATE	DOC DATE	PROJID	DISC	TITLE
41	16	C	15109	1	1		08-JUN-53		0	UN	GUARD STATION, W-16, W-SITE - PLOT PLAN AND DETAILS
41	16	C	15110	2	1		08-JUN-53		0	UN	GUARDHOUSE, PLAN AND DETAILS
41	16	R	3144	1	2		17-JUL-64	06-MAR-84	0	A	FLOOR PLAN, GUARD HOUSE
41	16	R	3664	1	1		27-SEP-66	15-SEP-66	3546	M	EQUIPMENT SURVEILLANCE SYSTEMS, ANNUNCIATOR PANEL
41	16	R	3835	1	1		28-SEP-66	15-SEP-66	3546	M	EQUIPMENT SURVEILLANCE SYSTEMS, ANNUNCIATOR PANEL
41	16	R	3837	1	1		28-SEP-66	15-SEP-66	3546	A	EQUIPMENT SURVEILLANCE SYSTEMS, FLOOR PLAN

## Historical Context of W Site, Technical Area 41

### Volume 2a – Archival Photographs and Index

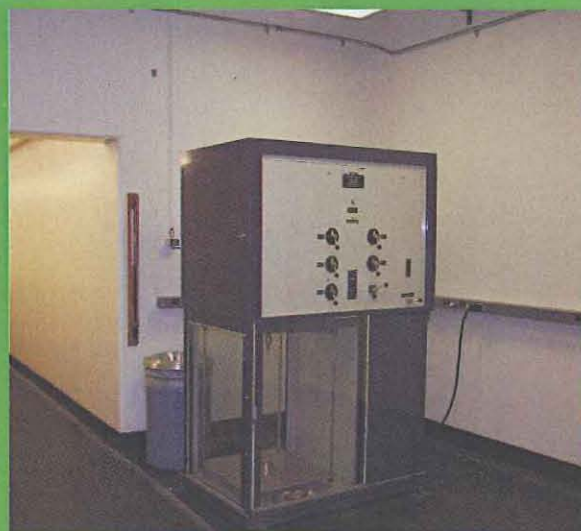
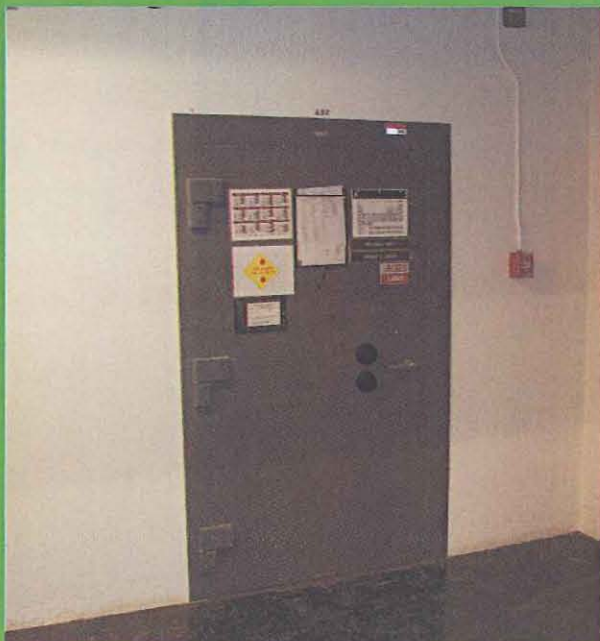
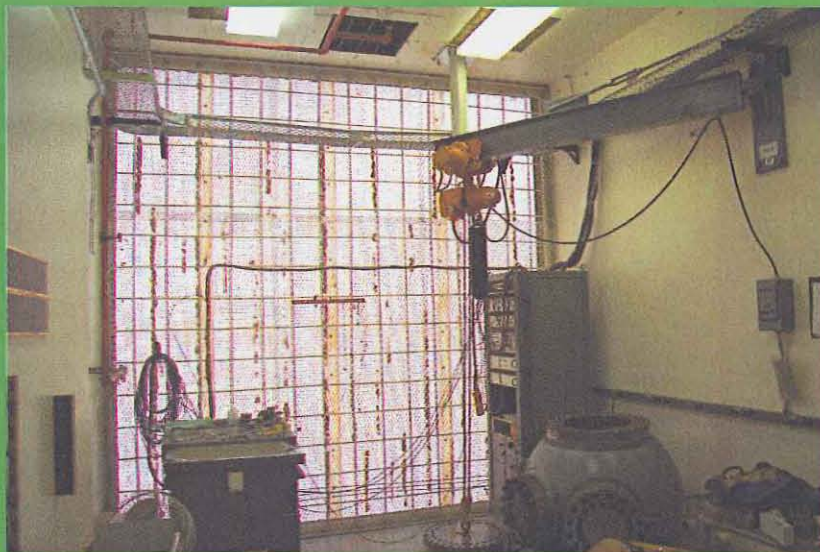



## Historical Context of W Site, Technical Area 41

### Volume 2b – Archival Photographs and Index

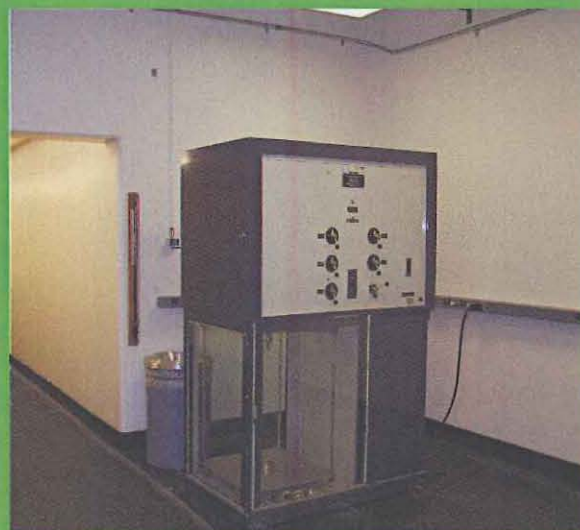
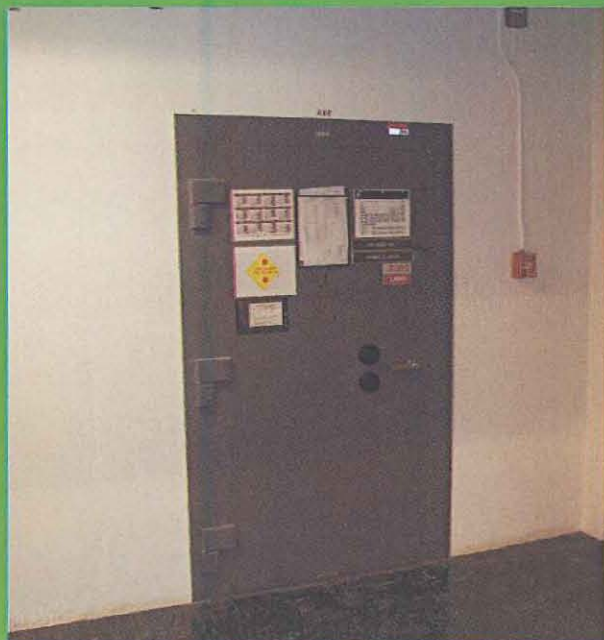

Los Alamos National Laboratory Historic Building Survey  
Index to Photographs

Technical Area 41 “W Site” or “Weapons Site”

Technical Area 41, Structures (1, 2, 3, 4, 6, 47, and removed properties 16, 30, and 53)

Los Alamos National Laboratory (LANL)

Los Alamos

Los Alamos County

New Mexico

Notes: The Laboratory is divided into different geographic areas called technical areas (TAs) that are designated by numbers. The properties at TA-41 are identified using the current LANL system of placing the “TA” prefix and TA number before each building and structure number, creating a unique property identifier (ie. TA-41-4).

TA-41 was initially built during the early Cold War to support nuclear weapons research and development. The technical area was used for the development of nuclear weapon components, weapons subsystems, and boosting systems, and also for long-term studies on critical weapon components. Two of the most significant facilities at TA-41, the tunnel and main storage vault (TA-41-1) and the “Ice House” (TA-41-4), provided the DOE with facilities for testing, monitoring, assembling, and storing nuclear weapons components. From 1954 to 1973, isotopic analyses of Nevada Test Site samples containing uranium and plutonium were performed at TA-41.

TA-41-1, -2, -3, -4, -6, -16, and -47 were determined eligible for the National Register of Historic Places under Criterion A in correspondence between the New Mexico State Historic Preservation Officer (SHPO) and LASO on May 22, 2002. Four of the properties are individually eligible for the National Register of Historic Places: TA-41-1, -2, -4, and -16. Three support structures (TA-41-3, -6, and -47), although identified with separate LANL property numbers, are physically connected to two of the eligible buildings and, while not individually eligible, are being documented in the same manner as the eligible buildings. Of the properties included in the memorandum of agreement (MOA), TA-41-16 and the office portion of TA-41-4 were eventually demolished. The high bay and rear laboratory portion of TA-41-4 was retained along with the vault (TA-41-1) and an associated guardhouse (TA-41-2). Three attached support structures (air intake TA-41-3, corridor TA-41-6, and exhaust stack TA-41-47) and some of the associated building utilities were also retained. (For additional information see related project documentation: *Decontamination and Decommissioning of Technical Area 41*, LA-UR-02-2663, Cultural Resource Report No. 204, and *Historical Context of W Site, Technical Area 41*, LA-UR-04-6492, Heritage Resources Report No. 231.)



Los Alamos National Laboratory Historic Building Survey  
Index to Photographs

Technical Area 41 "W Site", TA-41-1 (Vault)  
Los Alamos National Laboratory (LANL)  
Los Alamos  
Los Alamos County  
New Mexico

No other photos are allowed in this building because it contains classified material.

Photograph

Number

Description

RB02-005-029 TA-41-1, south side, roll-up entrance door, facing north.

RB02-002-008 TA-41-1, south side, roll-up entrance door, facing north.

Los Alamos National Laboratory Historic Building Survey  
Index to Photographs

Technical Area 41 "W Site", TA-41-2  
Los Alamos National Laboratory (LANL)  
Los Alamos  
Los Alamos County  
New Mexico

<u>Photograph Number</u>	<u>Description</u>
RN02-021-015	TA-41-2, north side and west side (front), facing southeast.
RN02-021-014	TA-41-2, north side, facing south.
RB02-002-004	TA-41-2, east side (back) and north side, facing southwest.
RN02-021-013	TA-41-2, east side (back), facing west.
RB02-002-006	TA-41-2, east side, facing west.
RN02-021-016	TA-41-2, south side and east side (back), facing northwest.
RB02-002-005	TA-41-2, south side and east side (back), facing northwest.
RN02-021-004	TA-41-2, room 200, northwest corner (west and north walls), facing northwest.
RN02-021-002	TA-41-2, room 200, northeast corner (north and east walls), facing northeast.
RN02-021-021	TA-41-2, room 200, southeast corner (east wall), facing south-southeast.
RN02-021-022	TA-41-2, room 200, southeast corner (east and south walls), facing southeast.
RN02-021-024	TA-41-2, room 200, southwest corner (south and west walls), facing southwest.
RN02-021-010	TA-41-2, room 100, battery backup room, facing west.
RN02-021-011	TA-41-2, room 100, battery backup room, facing southwest.
RN02-021-012	TA-41-2, room 100, battery backup room, facing southeast.

Los Alamos National Laboratory Historic Building Survey  
Index to Photographs

<u>Photograph Number</u>	<u>Description</u>
RN02-021-009	TA-41-2, room 100A, equipment/mechanical room, facing north-northeast.
RN02-021-008	TA-41-2, room 100A, equipment/mechanical room, facing northwest.
RN02-021-007	TA-41-2, room 100A, equipment/mechanical room, facing north-northwest.

Los Alamos National Laboratory Historic Building Survey  
Index to Photographs

Technical Area 41 "W Site", TA-41-3  
Los Alamos National Laboratory (LANL)  
Los Alamos  
Los Alamos County  
New Mexico

Photograph  
Number

Description

RN02-021-020	TA-41-3, south and east side of air duct for TA-41-1 (vault), facing north-northwest.
--------------	---

Los Alamos National Laboratory Historic Building Survey  
Index to Photographs

Technical Area 41 "W Site", TA-41-4 ("Ice House") and associated TA-41-47 (Stack)  
Los Alamos National Laboratory (LANL)  
Los Alamos  
Los Alamos County  
New Mexico

No other photos are allowed in this building because it contains classified material.

<u>Photograph Number</u>	<u>Description</u>
RB02-005-020	TA-41-4, west side (entrance), and south side of south portion of building, facing northeast.
RB02-005-031	TA-41-4, west side (entrance), and south side of south portion of building, facing northeast. Note walkway/corridor, TA-41-29 (at left) connecting this building to TA-41-30 to the left (west).
RB02-005-059	TA-41-4, west side (entrance), and north side of south portion of building, facing southeast.
RB02-005-058	TA-41-4, west side of north, central, and south portions, facing east. Note TA-41-47 (stack) in center.
RB02-005-057	TA-41-4, west side of north portion, facing northeast.
RB02-005-013	TA-41-4, south side and east side of south portion of building, facing northwest.
RB02-005-015	TA-41-4, east side of south portion of building, facing west-northwest.
RB02-002-003	TA-41-4, east and north sides of the south portion of building and east side of central "crossbar" portion of building, facing west.
RB02-005-016	TA-41-4, east side of central "crossbar" portion of building, facing west.
RB02-005-025	TA-41-4, north side of south portion of building and east side of central and north portion of building, facing southwest.



Los Alamos National Laboratory Historic Building Survey  
Index to Photographs

<u>Photograph Number</u>	<u>Description</u>
RB02-005-026	TA-41-4, north side of south portion of building and east side of central and north portion of building, facing southwest. Note TA-41-6, corridor (at right), connecting building TA-41-4 to the vault, TA-41-1.
RB02-002-002	TA-41-4, east side of north portion of building, facing northwest. Note TA-41-6, corridor (at right), connecting building TA-41-4 to the vault, TA-41-1.
RB02-005-041	TA-41-4, 2 <sup>nd</sup> floor hallway 200, facing east.
RB02-002-016	TA-41-4, 2 <sup>nd</sup> floor hallway 200, bathroom section with glazed ceramic tile, and looking into room 201, facing east.
RB02-005-043	TA-41-4, 2 <sup>nd</sup> floor hallway 200, facing west.
RB02-005-033	TA-41-4, 2 <sup>nd</sup> floor hallway 200, close-up of bathroom section with glazed ceramic tile, facing northwest.
RB02-005-044	TA-41-4, office room complex 201-201A-201G, at eastern end of 2 <sup>nd</sup> floor, facing northeast.
RB02-005-037	TA-41-4, room 201, looking towards offices 201A and 201B, facing east-southeast.
RB02-005-039	TA-41-4, room 201D, office, facing south.
RB02-005-040	TA-41-4, room 201C, office, facing southeast.
RB02-005-053	TA-41-4, room 215, conference room, facing east.
RB02-005-054	TA-41-4, room 215, conference room, facing southwest.
RB02-005-035	TA-41-4, room 218A, office, facing south.
RB02-005-048	TA-41-4, room 221, Group Office, facing southwest.
RB02-005-047	TA-41-4, room 221, Group Office, facing northwest.
RB02-005-046	TA-41-4, room 221, Group Office, facing northeast.
RB02-005-045	TA-41-4, room 221, Group Office, facing east.

Los Alamos National Laboratory Historic Building Survey  
Index to Photographs

<u>Photograph Number</u>	<u>Description</u>
RB02-005-036	TA-41-4, room 226, office, facing west-southwest.
RB02-005-076	TA-41-4, 2 <sup>nd</sup> floor stairwell, looking down, facing north.
RB02-005-049	TA-41-4, 2 <sup>nd</sup> floor hallway 200 to elevator and entrance into north "Ice House" portion of building, facing north.
RB02-002-028	TA-41-4, 2 <sup>nd</sup> floor hallway 200 and entrance into north "Ice House" portion of building, close-up, facing northwest.
RB02-005-077	TA-41-4, elevator with doors open.
RB02-002-029	TA-41-4, mezzanine 228 in highbay room 127, facing west.
RB02-002-030	TA-41-4, mezzanine 228 in highbay room 127, facing northeast.
RB02-002-031	TA-41-4, mezzanine 228 in highbay room 127, facing east.
RB02-002-014	TA-41-4, rooms 233/235/236/236C (all one space now) (front of photo to rear), facing east-southeast.
RB02-002-015	TA-41-4, rooms 236C/236/235/233 (all one space now) (front of photo to rear), facing west-southwest.
RB02-002-013	TA-41-4, room 236A, hood, facing southeast.
RB02-002-012	TA-41-4, room 237, day vault, facing northeast.
RB02-002-001	TA-41-4, room 240, concrete ceiling, facing northwest.
RB02-002-017	TA-41-4, room 242, source well in floor, facing northeast.
RB02-002-024	TA-41-4, room 242, source well in floor, facing northeast.
RB02-002-032	TA-41-4, room 252, facing southwest. Note fume cabinet.
RB02-002-022	TA-41-4, room 258 (pressure cell #1), facing north-northwest. Note pressure test vessels.

Los Alamos National Laboratory Historic Building Survey  
Index to Photographs

<u>Photograph Number</u>	<u>Description</u>
RB02-002-020	TA-41-4, room 260 (pressure cell #2), facing north-northeast. Note compressors that run the pressure test vessels.
RB02-002-019	TA-41-4, room 262 (pressure cell #3), facing north-northeast. Note pressure test vessels.
RB02-002-018	TA-41-4, room 256, control panel for pressure tests, facing east.
RB02-002-023	TA-41-4, hallway to room 244 (low-interference count room), facing east.
RB02-002-025	TA-41-4, hallway to room 244 (low-interference count room), wall ladder, facing northeast.
RB02-002-026	TA-41-4, room 244, balance, facing northwest. Note this balance was used to weigh the "Trinity Device."
RB02-002-027	TA-41-4, room 244, balance, facing east.
RB02-005-068	TA-41-4, 1 <sup>st</sup> floor hallway 100A, facing east.
RB02-005-067	TA-41-4, 1 <sup>st</sup> floor hallway 100A, facing west.
RB02-005-055	TA-41-4, 1 <sup>st</sup> floor hallway 100A to elevator and highbay, facing north.
RB02-005-074	TA-41-4, room 103, facing northeast. Note crane rail at ceiling.
RB02-005-071	TA-41-4, room 109, men's restroom, facing southwest. Note inner room (room 111) with showers and black glazed tile used to be a dark room.
RB02-005-072	TA-41-4, room 110, office, facing south.
RB02-005-070	TA-41-4, room 112, office, facing south-southwest.
RB02-005-056	TA-41-4, room 122, office, facing northeast.
RB02-005-069	TA-41-4, room 122, office, facing west.
RB02-005-066	TA-41-4, 1 <sup>st</sup> floor stairwell and room 105, facing north.

Los Alamos National Laboratory Historic Building Survey  
Index to Photographs

Technical Area 41 "W Site", TA-41-6  
Los Alamos National Laboratory (LANL)  
Los Alamos  
Los Alamos County  
New Mexico

<u>Photograph Number</u>	<u>Description</u>
RB02-005-028	TA-41-6, south side of corridor connecting building TA-41-4 to vault TA-41-1, facing northwest.
RB02-002-007	TA-41-6, south side of corridor connecting building TA-41-4 to vault TA-41-1, facing northwest.
RB02-002-011	TA-41-6, entrance into corridor from building TA-41-4, room 245, facing east.
RB02-002-009	TA-41-6, corridor connecting building TA-41-4 to vault TA-41-1, facing southwest.
RB02-002-010	TA-41-6, corridor and entrance into vault TA-41-1, facing northeast.

Los Alamos National Laboratory Historic Building Survey  
Index to Photographs

Technical Area 41 "W Site", TA-41-16 (Removed Property)  
Los Alamos National Laboratory (LANL)  
Los Alamos  
Los Alamos County  
New Mexico

Photograph

Number

Description

RB02-005-004	TA-41-16, south side (front) and east side, facing northwest.
RB02-005-003	TA-41-16, north side (back) and west side, facing southeast.
RB02-005-065	TA-41-16, room 101, facing north.

Los Alamos National Laboratory Historic Building Survey  
Index to Photographs

Technical Area 41 "W Site", TA-41-30 and TA-41-53 (Removed Properties, Not Eligible) and  
TA-41-7, -8, -9,, and -56 (Exempt Properties)

Los Alamos National Laboratory (LANL)

Los Alamos

Los Alamos County

New Mexico

Photos of these two buildings were taken to help depict what the entire site (TA-41) looked like at the time of review. Office building TA-41-30 and guard station TA-41-53 were added in 1959 and 1986 respectively. These buildings can be seen in some of the overall photos of the site that are listed at the beginning of this photo index.

Photograph

Number

Description

RB02-005-017	TA-41-30, west side and south side (entrance), facing northeast.
RB02-005-018	TA-41-30, south side (entrance) and east side, facing northwest. Note walkway/corridor, TA-41-29 (at right) connecting this building to TA-41-4 to the far right (east).
RB02-005-060	TA-41-30, east side and north side (back), facing southwest.
RB02-005-019	TA-41-29 (connecting walkway), south side (front), facing north. Note TA-41-30 on the left and TA-41-4 on the right.
RB02-005-061	TA-41-29 (connecting walkway), north side (back), facing south. Note TA-41-4 on the left and TA-41-30 on the right.
RB02-005-062	TA-41-53, west side (right side of photo) and TA-41-30 south side (front), facing east.
RB02-005-063	TA-41-53, south side (front); TA-41-30, south side (front) (at left rear); TA-41-29, connecting walkway, south side (front) (at central rear); and TA-41-4, west side and south side (front) (at right rear); facing north-northeast. Note TA-41-47 (stack) in rear.
RB02-005-006	TA-41-7, -8, -9, and -56, (exempt properties), facing north. TA-41-7 is a sanitary sewer chlorinator building, TA-41-8 is a sanitary sewer contact chamber, TA-41-9 is a sanitary sewer drying bed, and TA-41-56 is a sanitary sewer lift station.