

LA-UR-03-0726

## *Sentinels of the Atomic Dawn:*

*A Multiple-Property Evaluation of the Remaining  
Manhattan Project Properties  
at Los Alamos (1942–1946)*



**RRES-ECO Cultural Resources Management Team  
Risk Reduction and Environmental Stewardship Division  
LOS ALAMOS NATIONAL LABORATORY**

**Sentinels of the Atomic Dawn:  
A Multiple-Property Evaluation of the Remaining Manhattan Project Properties  
at Los Alamos (1942–1946)**

Historic Building Survey Report No. 215

**Los Alamos National Laboratory**

**March 28, 2003**

**Survey No. 858**

Prepared for the Department of Energy/National Nuclear Security Administration  
Los Alamos Site Office

prepared by

**Ellen D. McGehee**, Cultural Resource Manager, LANL Ecology Group

with

**Sheila McCarthy**, Historical Architect, Benchmark Consulting Group

**Ken Towery**, Architect, LANL Site and Project Planning Group

**John Ronquillo**, Consulting Engineer, Sigma Science, Inc.

**Kari L. M. Garcia**, Cultural Resource Manager, LANL Ecology Group

**John Isaacson**, Team Leader, Cultural Resources Management Team, LANL Ecology Group

RRES-ECO Cultural Resources Management Team  
Risk Reduction and Environmental Stewardship Division  
LOS ALAMOS NATIONAL LABORATORY

*Contents*

Introduction.....1

Section 1—Historical Context of the Manhattan Project at Los Alamos (Project Y).....4

Section 2—Descriptions of Manhattan Project Era Technical Areas.....19

Section 3—Property Summaries and Eligibility Recommendations.....47

Appendix A—Location Maps, Photographs, Descriptions, and Drawings  
of Remaining Manhattan Project Buildings and Structures (LANL) .....52

Appendix B—Photographs of Remaining Manhattan Project Buildings and Structures  
(Los Alamos County/Private Owned).....127

Notes.....134

Bibliography.....139

## Introduction

Los Alamos National Laboratory (LANL)'s Cultural Resources Management Team is conducting a multiple-property evaluation of LANL's remaining Manhattan Project era (1942–1946) facilities in support of the Department of Energy/National Nuclear Security Administration's National Historic Preservation Act compliance responsibilities. Short- and long-term planning decisions at LANL—coupled with the scheduled demolition of aging and obsolete facilities—are key factors in the decision to evaluate LANL's historic properties as contextually related groupings of buildings and structures, and not, as has been carried out in the past, on an individual basis.

Fifty-one properties from the Manhattan Project era remain at Los Alamos (Map 1). Of these, 44 retain historical and physical integrity and are eligible for listing on the National Register of Historic Places (12 of the 44 properties have previously been declared eligible). The 44 eligible properties were also assessed in terms of their potential for preservation and public interpretation, with the most historically significant properties being identified for permanent retention. Those eligible properties not slated for preservation will be evaluated on a case-by-case basis in the event they are scheduled for decontamination and decommissioning.

Ten of LANL's Manhattan Project properties are candidates for permanent retention. These properties represent Los Alamos's most important contributions to the history of World War II, including the development and testing of the “Trinity” device (buildings TA-16-516 and TA-16-517 at V Site), the development and testing of the first “Little Boy” bomb (buildings TA-8-1, TA-8-2, and TA-8-3 at the “Gun” Site), and the development and testing of the first “Fat Man” bomb and related implosion and criticality research (buildings TA-18-1, TA-18-29, and TA-22-1 and structures TA-6-37 and LA 131234 C).

A key element of the multiple property documentation format is context. A historical context provides information about historical patterns and trends and has clearly defined themes, geographical areas, and chronological periods (U.S. National Park Service 1999). Due to the complexity of subthemes associated with the main overarching theme of Nuclear Weapons Research and Development during the Manhattan Project, LANL's historic context for this time period is being written in two phases: an initial “umbrella” context (presented in this document), and subsequent in-depth thematic documents. An umbrella context presents general chronological and geographical information, identifies historical trends, and places local activities in a broader national context. The umbrella document also lists properties that are potentially associated with the overall context statement, and, most importantly, identifies the key themes. As currently envisioned, the subsequent thematic documents will be more in-depth historical discussions of the identified themes, emphasizing local historical patterns, trends, and interrelationships. Ultimately, these local themes will also be placed within the broader history of LANL, the DOE, the nation, and the world.

This umbrella context is divided into three main sections. The first section is an overview of the Manhattan Project and includes both national and local developments, concluding with a timeline of important Los Alamos events and a listing of the seven major Manhattan Project



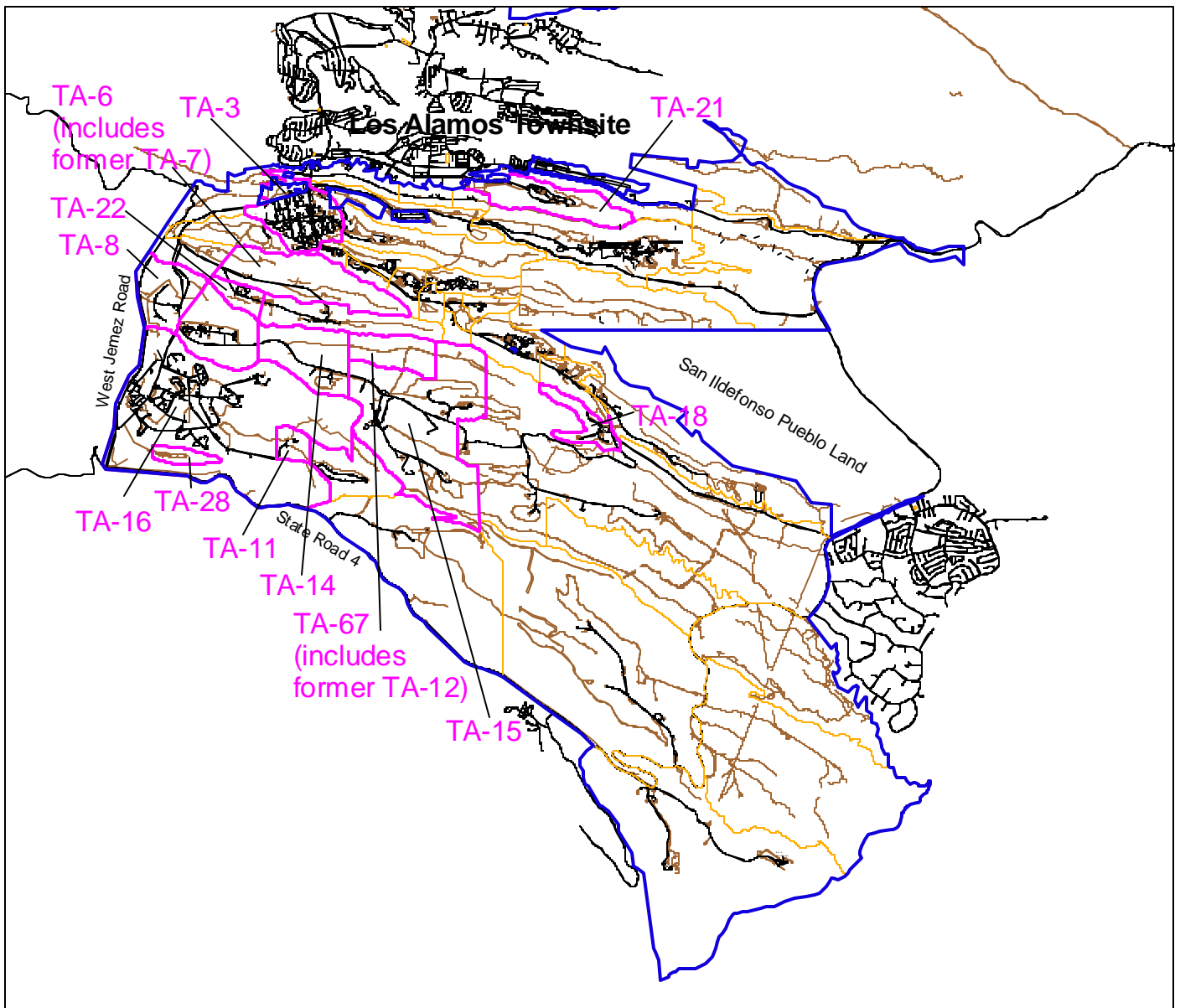

**Los Alamos**  
**National Laboratory**  
*Cultural Resources Management Team*  
*RRES-ECO Ecology Group*

1:110000

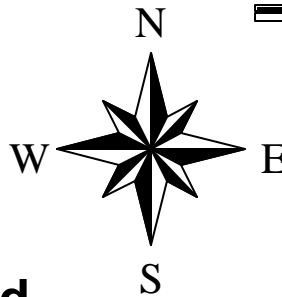
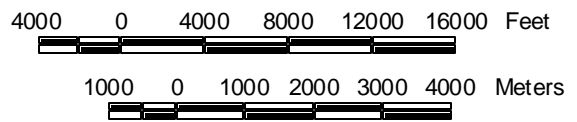

**LANL Boundary and  
 Technical Areas with Remaining  
 Manhattan Project Properties**

- ▭ Los Alamos National Laboratory
- ▭ Tech Areas with Remaining Manhattan Project Buildings
- ▭ Tech Areas
- Roads
- Road/dirt
- Park/pave
- Park/dirt

Map 1

themes. The second section discusses the relationship between testing facilities and the specific scientific and engineering problems that were faced during the weaponization of atomic energy. This section includes descriptions of the various technical areas that were in operation during the Manhattan Project at Los Alamos. The third and final section includes summary information related to the 51 remaining Manhattan Project properties at LANL. A table listing all remaining properties accompanies this section and contains current eligibility information, associated historical themes, and recommendations for National Register of Historic Places eligibility. Manhattan Project properties that are exceptionally significant and are good candidates for permanent retention are also identified in this table. Brief property descriptions and current photographs of LANL's Manhattan Project properties are included in Appendix A. Photographs of other local, non-LANL properties from this time period are included in Appendix B.

Much has been written about the Manhattan Project, at Los Alamos and elsewhere. Several excellent accounts are referenced here for additional reading: Edith C. Truslow's *Manhattan District History: Nonscientific Aspects of Los Alamos Project Y, 1942 through 1946*; David Hawkins, Edith C. Truslow, and Ralph Carlisle Smith's *Project Y: The Los Alamos Story*; Lillian Hoddeson, Paul W. Henriksen, Roger A. Meade, and Catherine Westfall's *Critical Assembly: A Technical History of Los Alamos during the Oppenheimer Years, 1943-1945*; F. G. Gosling's *The Manhattan Project: Making the Atomic Bomb*; LANL's *Los Alamos: Beginning of an Era, 1943-1945*; and, for a broader account of the background and development of the first nuclear weapons, Richard Rhodes's *The Making of the Atomic Bomb*.

## Section 1—Historical Context of the Manhattan Project at Los Alamos (Project Y)

### *Origins of the Manhattan Engineer District*

In 1939, Albert Einstein sent a letter to President Franklin Roosevelt advising him that Germany may have started work on developing the atomic bomb.<sup>1</sup> In the same year, University of California physicist, J. Robert Oppenheimer, organized a study conference that concluded that a fission bomb was feasible.<sup>2</sup> However, problems existed: the research efforts of universities and industry needed to be coordinated, and a process to produce sufficient fissionable material needed to be developed.<sup>3</sup> In 1941, President Roosevelt gave approval to pursue the development of an atomic bomb. Brigadier General Leslie Groves ultimately came to head the "Manhattan Project." Groves, in turn, chose Robert Oppenheimer to coordinate the design of the bomb.

**Map showing 3 of the 30 wartime technical areas located on the Pajarito Plateau**

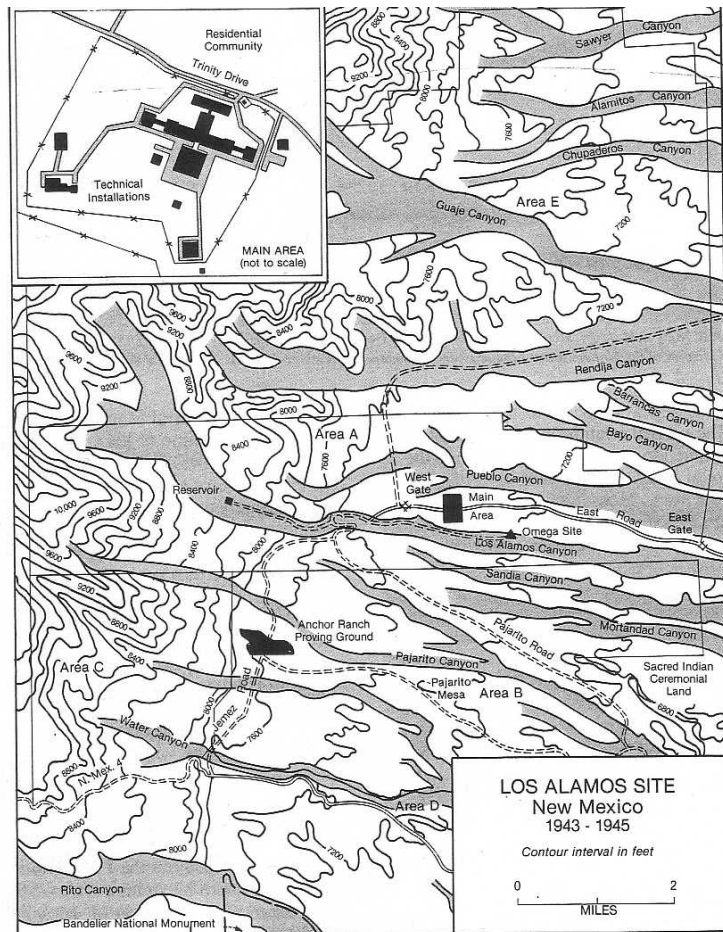

(from Gosling 2001)

## *Project Y*

A single research and design facility, isolated and secret, was proposed. This would enable top scientists and engineers from all over the country to work together to complete this daunting task. A site had to be chosen. General Groves had several criteria: security, isolation, a good water supply, an adequate transportation network, a suitable climate, an available labor force, and a locale west of the Mississippi.<sup>4</sup> The search for a site began in the fall of 1942. Major John Dudley eventually recommended Jemez Springs, N.M. Oppenheimer, who had visited the Pajarito Plateau as a young man and was familiar with the Los Alamos Ranch School, rejected Jemez Springs and suggested Los Alamos instead.<sup>5</sup>

The school's setting was indeed remote and afforded natural physical barriers for security, i.e., numerous canyons and cliffs. The ranch school had been in operation since 1918, and the 27 school buildings with numerous outbuildings could very easily support the small-scale facility Oppenheimer originally had in mind.<sup>6</sup>

On November 25, 1942, the War Department approved the appropriation of the Ranch School and on December 7, 1942, the school was officially notified.<sup>7</sup> Additional lands were acquired from nearby Government agencies, mostly Forest Service lands, and from the predominantly Hispanic homesteaders.<sup>8</sup> With the graduation of the last class of the Los Alamos Ranch School in 1943, the Pajarito Plateau was balancing on the brink of change; a scientific revolution was in the making.



(Photo Courtesy of the Los Alamos Historical Society)

**Homesteaders Working in the Anchor Ranch Fields, Los Alamos, New Mexico**

A suitable site selected, Oppenheimer and his staff moved to Los Alamos to begin work. The recruitment of some of the country's "best scientific talent" and the construction of technical buildings were top priorities.<sup>9</sup> The University of California agreed to operate the site, code name "Project Y," under contract with the government.



(RG 227, OSRD, S-1 Files, "MED Reports on Facilities, Los Alamos," NARA, College Park, MD)  
**Otowi Bridge (1942)**



(RG 227, OSRD, S-1 Files, "MED Reports on Facilities, Los Alamos," NARA, College Park, MD)  
**Ashley Pond and the Jemez Mountains (1942)**

## *Early Construction*

The Albuquerque District Office of the Corps of Engineers began planning for the establishment of an installation in northern New Mexico as early as December 1942. Standard Army construction procedures were in force, and the first priority was the construction of technical and office buildings.<sup>10</sup> The architectural style of early Los Alamos was “typical Mid-Twentieth Century Hurry-Up Military, and uniformly hideous.”<sup>11</sup>



(LANL, IM-4 Photography)

### **Early Los Alamos and Main Technical Area**

The early Los Alamos town site was a fenced community resembling a military post. The Main Technical Area, later known as Technical Area (TA) 1, was fenced and separated from the rest of town, and only specially badged workers were allowed inside the guarded laboratory area. The Army Corps of Engineers was responsible for the maintenance of buildings and utilities. Contract companies, although ultimately supervised by Army personnel, carried out new construction. The M. M. Sundt Company was the first construction contractor, working at Los Alamos until the end of 1943. For three months in early 1944, the J. E. Morgan Company built some of the early Los Alamos housing. R. E. McKee, the final contractor of the Project, completed much of the wartime construction. The architect-engineer, W. C. Kruger, started developing the plans for the town and technical areas in late 1942 and continued working at Los Alamos throughout the war years.<sup>12</sup>

### *Early Administration*

General Groves had overall responsibility for both the military and technical administration of the various Manhattan Project sites. Los Alamos had five commanding officers between 1943 and the end of 1946: Lt. Colonel Harman, Lt. Colonel Ashbridge, Colonel Tyler, Colonel Seeman, and Colonel Gee. These Army officers were responsible for the day-to-day administrative details and for the activities of the military personnel.<sup>13</sup> Robert Oppenheimer was the scientific director and was responsible for the scientific and technical details of Project Y. Oppenheimer reported to General Groves and worked closely with J. B. Conant, Groves's technical advisor.<sup>14</sup>



(LANL, IM-4 Photography)  
**Los Alamos Main Gate**

### *Other Manhattan Engineer District Sites*

When President Roosevelt approved the establishment of the Manhattan Project on December 28, 1942, he authorized the construction of facilities that would ultimately produce the fissile material needed for the weapons designed in Los Alamos. By December 1942, plans for the development of the Clinton Engineer Works (Site X, later known as Oak Ridge) in Tennessee were already well underway. Other important facilities associated with the Manhattan Project included the Metallurgical Laboratory in Chicago and the Hanford Engineer Works (Site W) in Washington State. On December 2, 1942, scientists working under the leadership of Enrico Fermi achieved the first self-sustained nuclear chain reaction in Chicago. Fermi's demonstrated production pile design would later be recreated at Oak Ridge.<sup>15</sup>



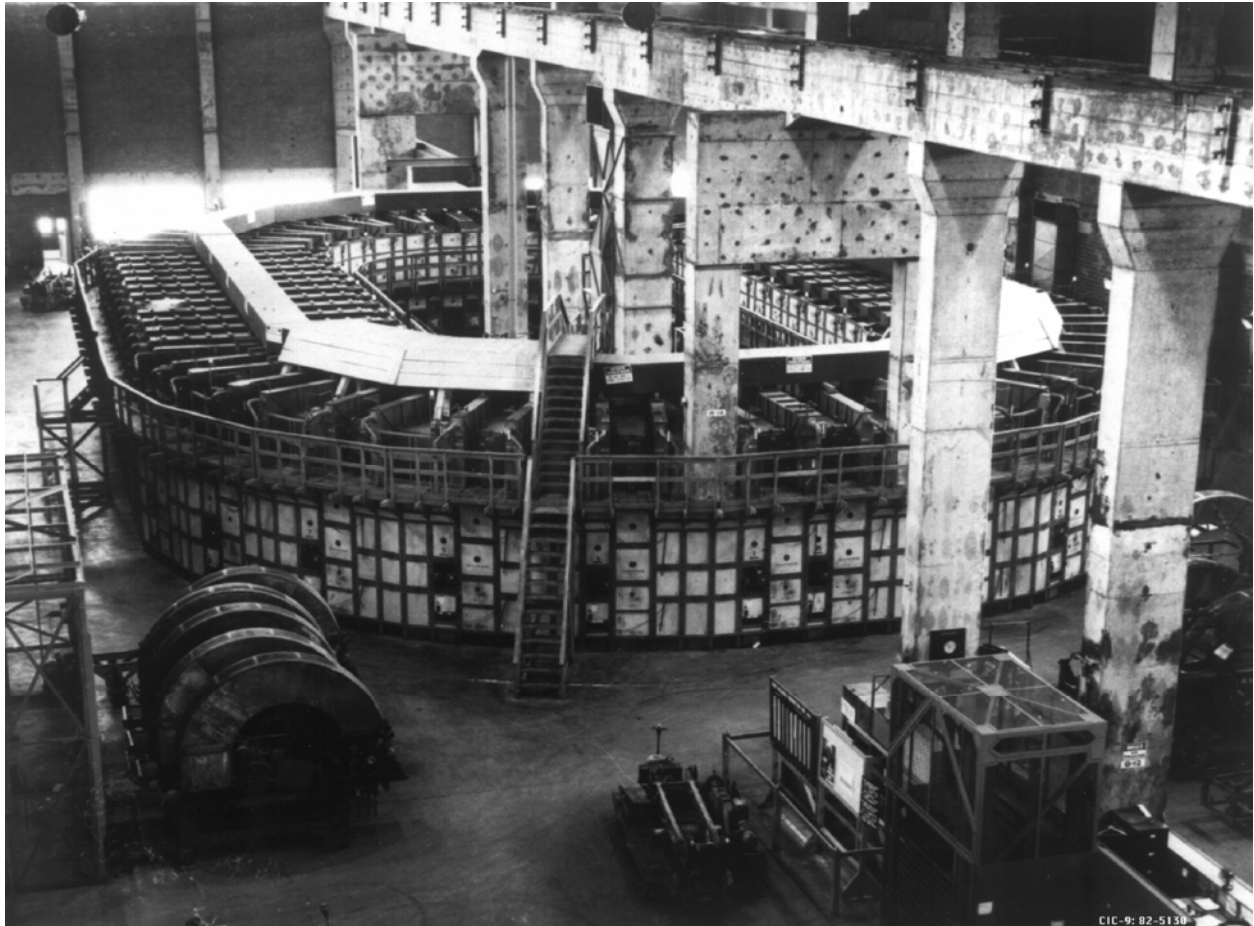

(LANL, IM-4 Photography)  
**Y-12 “Racetrack” at Oak Ridge (Clinton Engineer Works)**

During the next two years, the preparation of fissionable core materials would be conducted on a parallel time line at Oak Ridge and Hanford. The separation of uranium-235 from uranium-238 could not be done using a chemical process. Two physical separation processes were developed at Oak Ridge: gaseous diffusion separation and electromagnetic separation. Small quantities of plutonium for use at Los Alamos were first produced using the Oak Ridge “pile.” However, larger production reactors were needed to produce the necessary volume of plutonium for bomb cores. Hanford reactors were soon producing plutonium nitrate for shipment to Los Alamos. The first plutonium-239 arrived at Los Alamos from Oak Ridge in the fall of 1943. Larger gram amounts—first from Oak Ridge, then from Hanford—started arriving early in 1944. The first kilogram of highly enriched uranium arrived from Oak Ridge in September 1944.<sup>16</sup>

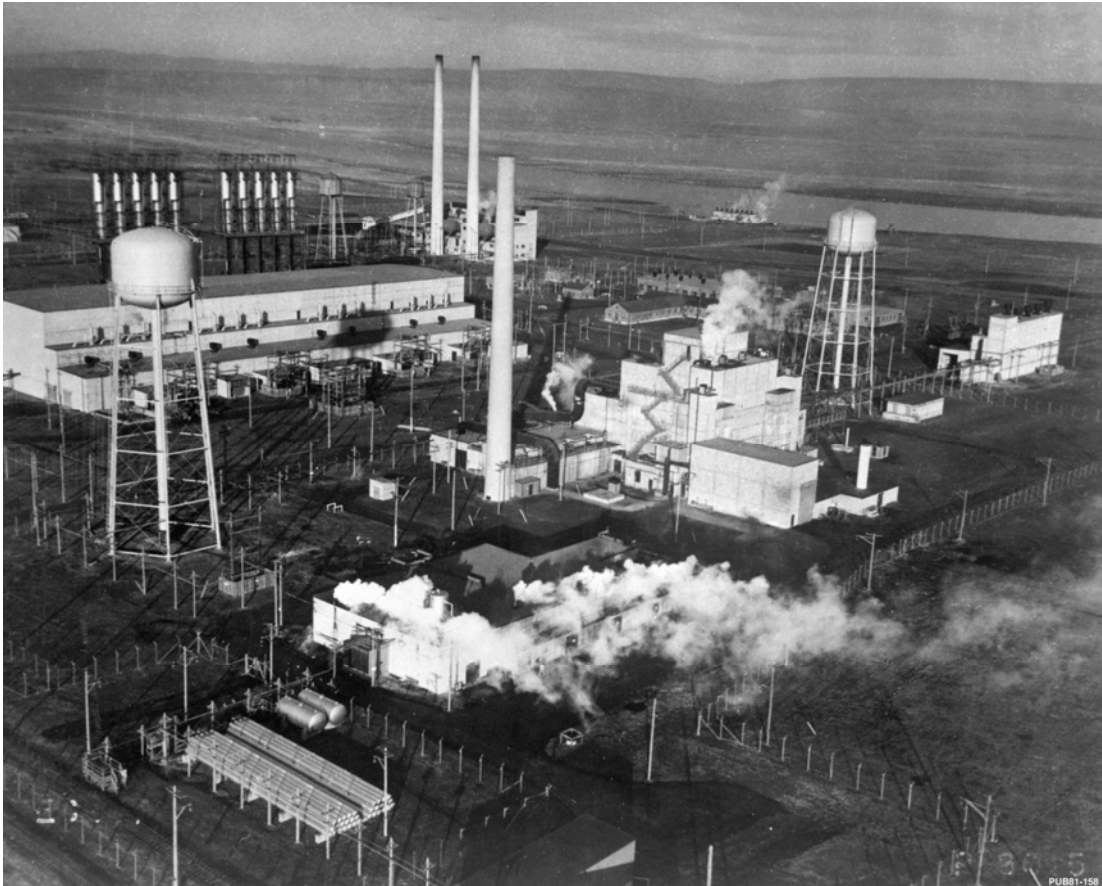

(LANL, IM-4 Photography)  
**Plutonium Production at Hanford, Washington**

### *Scientific History*

Although the fission bomb was conceptually attainable, many difficulties still stood in the way of producing a usable weapon. Technical problems included assembling fissionable material into a supercritical mass, the timing of the release of energy from fissionable material, and the engineering challenges of having the device fit into a “deliverable” bomb casing. Nuclear material and high explosive studies were of immediate importance.<sup>17</sup>

Two bomb designs appeared to be the most promising: a uranium “gun” device and a plutonium “implosion” device. The gun device was conceptually simple and involved shooting one subcritical mass of uranium-235 into another at sufficient speed to avoid pre-detonation. Together, the two subcritical masses would form a supercritical mass, releasing a tremendous amount of nuclear energy.<sup>18</sup> This method led to the development of the “Little Boy” device. Because it was conceptually simple, “Little Boy” was never tested before its use at Hiroshima.

In order to achieve the wartime goal of researching, developing, and testing the first atomic bomb, the chemical and metallurgical properties of various nuclear materials had to be researched. One of the first tasks was to develop methods to purify the plutonium that would be coming to Los Alamos, first from Oak Ridge, Tennessee, and later from Hanford, Washington.

Other early priorities of the radiochemistry program included the development of a neutron initiator for the first nuclear weapons and the preparation of materials for nuclear experiments. Necessary research on the physical properties of uranium and plutonium was conducted—especially research relating to metal alloys.<sup>19</sup>

While the radiochemistry program was developing processes for working with the as yet unreceived plutonium and uranium that would be used in the first bombs, other Los Alamos scientists conducted the first experiments on methods of plutonium purification using other elements as stand-ins. This work was conducted in D Building, a wooden laboratory building located south of Ashley Pond in the Main Technical Area, TA-1. Initial plutonium research, metallurgy, and World War II plutonium core production were carried out in this facility. The world's first significant piece of plutonium metal was produced in the centrifuge at D Building in the spring of 1944.<sup>20</sup>

Of the two earliest weapon designs, the gun method was easier to develop than the implosion method. Furthermore, Los Alamos scientists thought that both uranium and plutonium could be used with the gun design. The implosion design was recognized early on as a technically efficient approach, but was primarily intended to be a back up to the gun device in case unexpected problems arose; initial research on implosion was seen as more of an intellectual challenge. In 1943, Oppenheimer, confident in the success of the gun program, allowed a small number of scientists to pursue this alternative approach.<sup>21</sup>

In 1944, the gun design was determined to be unsuitable for use with plutonium. The main reason being that plutonium produced in nuclear reactors contained an isotope (plutonium-240) that released neutrons. This high-neutron background would cause the nuclear chain reaction to start prematurely if an assembly method as slow as the gun device was used.<sup>22</sup> The realization that plutonium could not be used in the gun device was the cause of a major reorganization at the Laboratory in August 1944.

A crisis ensued. Groves, wanting to preserve the investment that had been made in plutonium production (hundreds of millions of dollars), ordered a plutonium bomb assembled by other means. The only possible alternative was implosion, an assembly explored thus far at Los Alamos only as a contingency...As a result, Los Alamos was forced to turn its relatively small implosion program into a model "big science" effort involving hundreds of workers.<sup>23</sup>

Fortunately, the development of the gun weapon was well underway. This allowed the Laboratory to mobilize its limited resources and accelerate research on implosion in hopes of developing a plutonium weapon that could be used in addition to the uranium gun device.<sup>24</sup> Scientists were less confident about the implosion design, which used shaped high explosives to compress a subcritical mass of plutonium-239. The symmetrical compression would increase the density of the fissionable material and cause a critical reaction. This approach was much more difficult to perfect.<sup>25</sup>

At least seven diagnostic testing methods were developed to study the inner workings of implosion; the greatest difficulties came from the need to “record events inside an explosive and to time them within an uncertainty of approximately microseconds.”<sup>26</sup>

#### Terminal Observations

This method was one of the first used to study implosions; it involved studying the physical remains of the test shots to diagnose the success of the implosion tests.<sup>27</sup>

#### Magnetic Method

The basic principle used in the magnetic method has to do with changes in a magnetic field: when metal moves into a magnetic field, the field is changed. The magnetic method was used to study the current produced in a surrounding coil (induced by the inward motion of imploding metal). This diagnostic method gathered important information on the velocity and other characteristics of an implosion.<sup>28</sup>

#### X-ray

The counter X-ray method was designed to work in combination with the magnetic method. The method used X-rays as a time function on a grid of Geiger counters in an attempt to follow the course of an implosion. The counters produced a pulse when crossed by a charged particle.<sup>29</sup>

#### Betatron

The betatron method was similar to using flash X-ray as a diagnostic tool; however, this method used gamma radiation from accelerating electrons. The betatron radiation created a record in a cloud chamber after passing through a test implosion.<sup>30</sup>

#### Flash Photography and Rotating Prism Camera

The flash photography method used X-ray and photographic techniques to gather data about detonation, lenses, and initiators.<sup>31</sup>

#### RaLa (Radiolanthanum)

This method was used to determine the compression of imploded metal. A diagnostic radioactive source was inserted into the center of a metal shell and the test assembly was remotely detonated. The results documented compression as a function of time and were invaluable in establishing the final design of the implosion bomb.<sup>32</sup>

#### Electric Pin

The electric pin method was used to gather information about the shape of implosions. The positions of various points on the liner of a tamper (as a function of time) were determined by using electrical pickups or direct connections.<sup>33</sup>

### *Final Preparations*

In 1944, despite the myriad of diagnostic techniques being used, uncertainties surrounding the implosion design necessitated a search for an appropriate test site for the implosion method. The Alamogordo Bombing Range in south-central New Mexico was selected. A trial run involving 100 tons of TNT was conducted at "Trinity Site" on May 7, 1945. This dress rehearsal provided measurement data and simulated the dispersal of radioactive products.<sup>34</sup> The Trinity test was planned for July and its objectives were "to characterize the nature of the implosion, measure the release of nuclear energy, and assess the damage."<sup>35</sup> Concurrent airborne operations to test the deliverable weapons casings for the gun and implosion bombs, nicknamed "Pumpkins," were being conducted at Wendover Field in Utah. By June 1945, preparations for a staging area in the Pacific on the Island of Tinian were well underway.<sup>36</sup> The world's first atomic device was successfully detonated in the early morning of July 16, 1945. "Little Boy," the untested uranium gun weapon, was exploded over the Japanese city of Hiroshima on August 6, 1945. "Fat Man" was exploded over Nagasaki three days later on August 9, 1945. The war with Japan was essentially over.



(LANL, IM-4 Photography)  
**Trinity Base Camp**

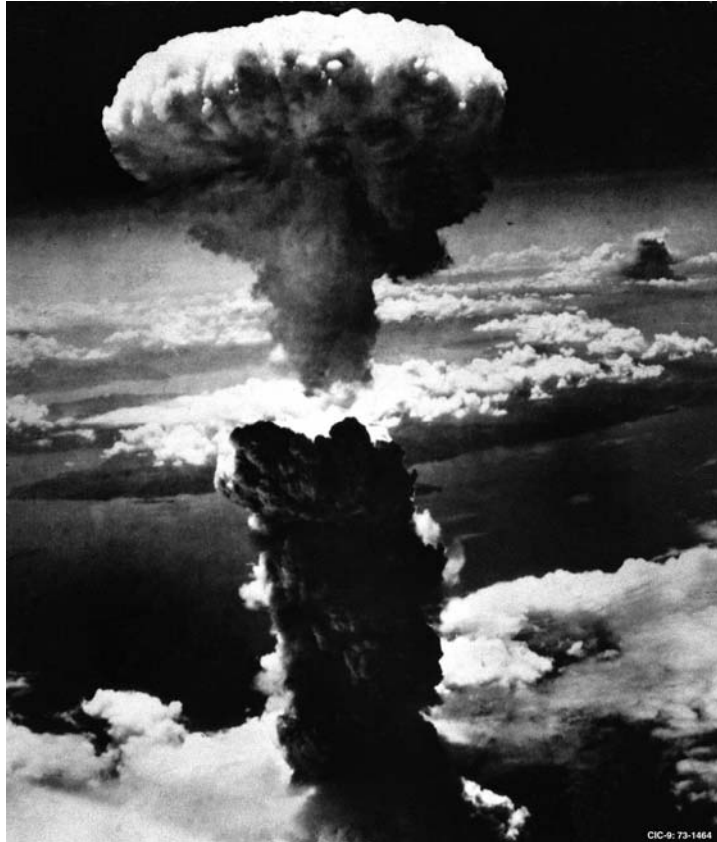

(LANL, IM-4 Photography)  
**“Fat Man” over Nagasaki, Japan**



(LANL, IM-4 Photography)  
**Hiroshima, after “Little Boy”**

## *Post-War Manhattan Project*

Los Alamos's role in the Manhattan Project did not conclude with the end of World War II. Refinement and testing of weapon designs continued at Los Alamos, and post-war weapons tests began in 1946 in the Pacific. General Groves remained in charge of the post-war Manhattan Project. His goal was to protect America's nuclear supremacy and to continue operations at key facilities. Some of the fissile material production facilities at Hanford and Oakridge were shut down or put on stand by, but research and development continued at Los Alamos. Groves tasked Los Alamos with the production of the country's first atomic stockpile; components would be produced at Los Alamos, but weapon assembly would be carried out at nearby Sandia Base in Albuquerque.<sup>37</sup>



(Photos from the Department of Energy)

Test Able



Target Fleet



Test Baker

Actual weapons testing continued during the tail end of the Manhattan Project with “Operation Crossroads,” a testing program that led to the detonation of two plutonium “Fat Man”-type bombs in the Pacific. On July 1, 1946, Shot Able was dropped from a B-29 in the area of Bikini Atoll. The blast from Able sank three ships that were part of a target fleet of unmanned ships; two additional ships sank within 27 hours after the test.<sup>38</sup> Shot Baker was the second and final Crossroads weapons test. On July 25, 1946, Baker was detonated underwater—damaging empty ships, shooting water into the air, and leaving radioactive fallout in its wake. These tests inaugurated the atmospheric testing program that started in the spring of 1948 and continued in the Pacific and at the Nevada Test Site during the 1950s and 1960s.<sup>39</sup>

For all practical purposes, the termination of Manhattan Project activities in Los Alamos came in late 1946 with the creation of the Atomic Energy Act and the transfer, in January 1947, of all atomic energy activities from the Manhattan Engineer District to the newly created Atomic Energy Commission.



## Manhattan Project Historical Themes and Subthemes

The DOE has identified corporate-level contexts related to its historical operations; significant contexts are associated with DOE's World War II and Cold War weapons programs. Several of the associated themes have little connection to LANL operations, such as Milling and Mining, Fissile Material Production, and Power Administration. DOE-wide themes that have strong associations with LANL's mission include Nuclear Weapon Components and Assembly; Nuclear Weapon Design and Testing; Nuclear Propulsion; Peaceful Uses: Plowshare, Nuclear Medicine, Nuclear Energy, and Nuclear Science; and Energy and Environment.

Key themes associated with the overall Manhattan Project context at Los Alamos are listed below. While this "umbrella" document contains only a brief identification of themes, future facility-specific documents will include more in-depth historical discussions of the Manhattan Project themes, emphasizing local historical patterns, trends, and interrelationships. Ultimately, specific local themes will also be placed within the broader history of LANL, the DOE, the nation, and the world.

There are seven main themes associated with the Manhattan Project at Los Alamos. Although primarily linked to World War II activities, many of the themes and subthemes listed below span both the Manhattan Project and Cold War eras.

- 1) Weapons Research and Development, Testing, and Stockpile Support – Subthemes include the development of the Atomic Bomb and the Hydrogen Bomb, with related technical developments (High Explosives, Initiators, Detonators, Implosion, Limited Production), and testing (Pacific Testing: Operations Crossroads).
- 2) Origins of Super Computers – Subthemes include the use of early workers or "Computers," to perform calculations on business machines, and the use of ENIAC support for weapons calculations.
- 3) Reactor Technology – Subthemes include the early reactors Lopo, Hypo, and Clementine.
- 4) Biomedical/Health Physics – Subthemes include radiation effects on humans and animals, and the relationship between early fatalities and the development of standards, exposure limits, and remote operations for radioactive materials, chemicals, and explosives.
- 5) Strategic and Supporting Research – Subthemes include Nuclear Science and Pioneering Physics.
- 6) Administrative and Social History – Subthemes include the general administration of the Laboratory, the social organization of the Laboratory and town, and security practices.
- 7) Architectural History – Subthemes include construction history and architectural styles.

## *Manhattan Project Timeline*<sup>40</sup>

### **1942** (Establishment of Manhattan Engineer District)

November—Groves selects Los Alamos, New Mexico, as the site for a bomb laboratory (codenamed Project Y) and chooses Oppenheimer as scientific director.

December—Construction contractor and architect-engineer firm selected.

### **1943** (Main Technical Area Developed)

March—Researchers begin arriving at Los Alamos.

April—Bomb design work begins at Los Alamos.

Mid-1943—Pajarito Site (TA-18) used by Radioactivity Group.

September—Anchor Ranch West (TA-8) gun program started.

October—Anchor Ranch East (TA-9) casting room operational.

### **1944** (Project Y Reorganized)

February—Omega Site (TA-2) developed.

May—Initial water boiler reactor criticality at TA-2 (LOPO Reactor).

May—S Site (TA-16) starts limited high explosives operations.

July—Plutonium gun design is dropped, major reorganization of early Laboratory, shift to implosion research (12 technical areas dedicated to implosion research and development).

Post-July—Magnetic method of implosion study conducted at TA-18.

August—S Site is operational on larger scale.

August—Operations start at TA-13 (flash X-ray implosion diagnostics).

October—RaLa implosion tests begin at Bayo Site (TA-10).

### **1945** (Finalizing Designs and the End of the War)

Early 1945—Betatron operational (TA-11).

1945—Development of the high-explosive lens system (TA-16). Exploding bridge wire technology concurrently developed to detonate the lens system (TA-6).

1945—Weapons designs frozen (RaLa work at TA-10 plays vital role in final implosion design).

1945—Airborne tests of deliverable weapons casings conducted at Wendover Field in Utah.

June 1945—Preparations well underway for staging area at Tinian Island.

July 16, 1945—Plutonium bomb tested at Trinity Site near Alamogordo, New Mexico.

August 6, 1945—Little Boy (gun model uranium bomb) is dropped on Hiroshima.

August 9, 1945—Fat Man (implosion model plutonium bomb) is dropped on Nagasaki.

August 21, 1945—H. Daghlian fatal accident at Omega Site (TA-2).

Summer—TA-21 (DP Site) plutonium facility starts operations.

1945—Norris Bradbury becomes director of the Laboratory.

**1946** (Beginning of Atomic Energy Commission)

1946—Plutonium-fuel reactor called Clementine achieves criticality at TA-2.

April—Critical assembly work begins at TA-18.

May—L. Slotin fatal accident at TA-18.

July—Operation Crossroads conducted in the Pacific; Shot Able is air dropped in the Bikini Island area on July 1st, and Shot Baker is detonated underwater on July 25<sup>th</sup>.

August 1, 1946—President Truman signs the Atomic Energy Act of 1946.

**1947** (End of Manhattan Engineer District)

January—All atomic energy activities are transferred from the Manhattan Engineer District to the newly created Atomic Energy Commission.

August—The Manhattan Engineer District is abolished.

## Section 2—Descriptions of Manhattan Project Era Technical Areas

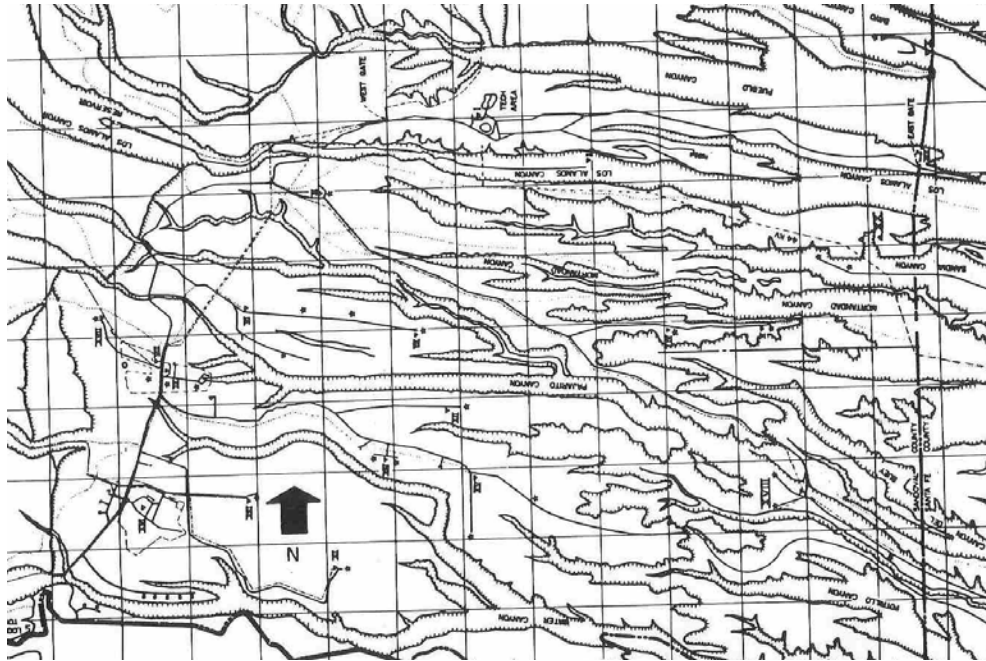

(from Hawkins *et al.* 1988)  
**Map Showing Early Technical Areas**

### *Introduction*

Much of the theoretical basis for atomic weapons was well known by the time Oppenheimer started assembling his team of scientists in early 1943. Specific scientific and engineering details still had to be worked out, often through repetitive testing.<sup>41</sup> Many of the outlying facilities were constructed in support of the arduous testing program that the Laboratory mounted in response to very specific research problems; these were problems that had to be solved in order to produce atomic weapons for wartime use.

Scientists and workers used many different problem-solving methods to accomplish the technological feats associated with the development of the first atomic weapons. Many of these methods were variations on the “trial and error” approach and were not based on thorough analysis—traditional analytical methods would not produce the rapid results needed under the strict time deadlines. In her introduction to *Critical Assembly*, Lillian Hoddeson presents six different problem-solving methods used at Los Alamos in conjunction with the more traditional scientific methods: the “Edison” approach, trying various materials or systems one after another; the “shotgun” approach, throwing all known techniques and knowledge at a problem; “overlapping” approaches, using multiple approaches at the same time with the hope that incomplete solutions might be combined to solve a problem; the “small-scale model” approach, proving principles on a smaller scale to save time and materials; the “iteration” approach, a fine-tuning of models from repeated testing; and the “numerical analysis” approach, using early computing machines to supplement analytical methods.<sup>42</sup> Indeed, when faced with one of the most critical wartime problems, that of the unsuitability of plutonium for use in the gun device,

the concept of implosion was made into a reality because the Laboratory used every means at its disposal; Los Alamos used its technical knowledge, manpower, and morale to “throw the book” at the “implosion problem.”<sup>43</sup>

The practical problem-solving methods used during field testing at the outlying technical areas had direct connections to the ongoing scientific problems at Project Y. The development of diverse and complex engineering methods relating to detonator, initiator, and high explosives research was a primary accomplishment of the wartime Laboratory.

The importance of engineering methods is best illustrated by Los Alamos’s response to one of its greatest scientific hurdles: the unsuitability of the plutonium gun device and the need to develop an alternative weapon design. In July 1944, Project Y was reorganized to solve the implosion problem. That the implosion weapon was successfully developed was ultimately related to the diversity of problem-solving methods used at Los Alamos, from the dedicated use of at least 12 outlying technical areas for implosion testing, to the use of overlapping and iterative problem-solving methods exemplified by the simultaneous development of the RaLa, betatron, magnetic, electric pin, and X-ray diagnostic methods. “Throwing the book” at the problem of implosion involved using 100,000 pounds of high-explosives a month during peak wartime testing, producing thousands of detonators for field tests, and sparing no expense in the destructive, but data-rich, RaLa program. These combined engineering approaches came to fruition with the successful Trinity test on July 16, 1945.

### **TA-1, Main Technical Area**



(LANL, IM-4 Photography)  
**TA-1 (1950)**

TA-1 was the original core area of the early Laboratory, and scientific work started at the Main Technical Area in early 1943. The laboratory area, although located near housing and administrative areas, was fenced-off from the main portion of the town of Los Alamos. The first laboratory buildings were located in the vicinity of Ashley Pond.



(LANL, IM-4 Photography)

**TA-1, Ashley Pond and Early Technical Area Buildings**

The initial plans for the early Laboratory, as laid out by Oppenheimer and others, included a scientific staff of about 100 employees along with a greater number of support staff made up of administrative, technical, and shop employees. The Theoretical Administration or “T” Building was the first building constructed in the Main Technical Area. The building contained offices, the technical library, a photographic library, a drafting room, and a classified document vault. Other important early technical buildings included “W” Building, built to house the Van de Graaff accelerator; “X” Building, built to house the cyclotron; “Y” Building, the High Pressure Gas Laboratory; and “Z” Building, a high voltage laboratory built to house the Cockcroft-Walton accelerator.

The Main Technical Area expanded its laboratory, shop, and plant facilities in response to the continued growth of Project Y, stimulated in part by the shift to large-scale operations in 1944. Important later construction included the completion of an annex to “D” Building (the plutonium laboratory), and the completion of the Sigma Building (the Metallurgy and Refractories Laboratories).<sup>44</sup>

## TA-2, Omega Site

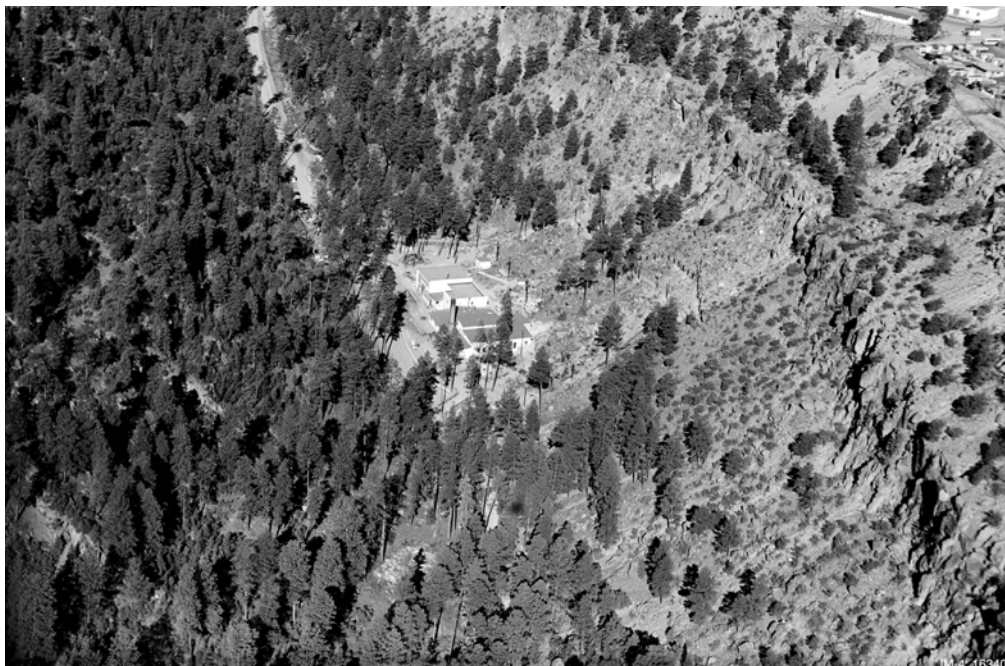

(LANL, IM-4 Photography)  
**TA-2, Omega Site (1950)**

The main reactor building at TA-2, completed in February 1944, was built to house the world's first enriched uranium reactor (the Water Boiler Reactor). On May 9, 1944, the Water Boiler produced its first "divergent chain reaction." An adjacent facility, built in 1946, housed one of the earliest plutonium-fuel reactors (the Clementine Reactor). The main reactor building housed the low-powered or "LOPO" Water Boiler Reactor, associated laboratories, and, later, critical assemblies. Perhaps the most important contribution of this early reactor was its role in providing a "general check of theory;" the Water Boiler could be used to investigate a chain-reacting system and to test basic theories of bomb design.<sup>45</sup>

**The Water Boiler  
Reactor Building, TA-2**



(LANL, RRES-ECO)



TA-2, situated in the bottom of Los Alamos Canyon, was isolated from other laboratory and housing areas for safety reasons. Safety concerns centered on the risk to unprotected people from the possibility of radioactive dispersion into the atmosphere—accident scenarios ranged from a mild explosion to an uncontrolled chain reaction.

The LOPO reactor was redesigned in mid-1944 and rebuilt for higher power operation (the HYPO reactor). At this time, the Critical Assemblies Group joined the Water Boiler Group at Omega Site, and experiments with critical amounts of active materials were conducted at the TA-2 facility. These experiments explored the design of the implosion device's "pit assembly."<sup>46</sup> Preliminary investigations also led to the development of safe handling and fabricating procedures so that uncontrolled nuclear chain reactions could be prevented. An important experiment conducted at TA-2 was known as "tickling the dragon's tail;" "the dragon" experiment created a controlled supercritical reaction using prompt neutrons alone.<sup>47</sup> Critical assembly research continued at TA-2 until August 21, 1945, when staff member Harry Daghlian accidentally received a lethal radiation dose from a brief supercritical arrangement of his critical assembly experiment. As a result of this accident, critical assembly work was transferred to Pajarito Site (TA-18).<sup>48</sup>

In 1946, a new reactor was built at Omega Site in a permanent building immediately adjacent to the wooden Water Boiler building. This reactor, known as "Clementine," was a fast plutonium reactor that used mercury as a coolant.<sup>49</sup>

### TA-3, South Mesa (SM) Site



(LANL, RRES-ECO)  
**Manhattan Project Era Building, TA-3**

The original TA-3 was a small testing area located at the present-day site of LANL's main administrative offices. Facilities associated with the technical area included temporary wood-frame structures, a few storage magazines and test chambers, standard prefabricated hutments, and a high explosives burn pad.<sup>50</sup> Beginning in 1943, TA-3 was used for the assembly and testing of detonators. The goal for these experiments was to produce better timing results using electric detonating devices. Standard detonator work was transferred to TA-6 (Two Mile Mesa Site) in April 1946, although experimental detonator loading and testing continued at TA-3 for several years. Most of the early structures and buildings associated with the Manhattan Project use of South Mesa were removed in 1949.<sup>51</sup> The first permanent post-war buildings at TA-3 were constructed in the late 1940s and early 1950s.

### TA-4, Alpha Site

TA-4 was a small firing site where the magnetic method was used to study implosions in spheres. Facilities located at the site included a control building, an assembly building, explosives magazines, and a main explosives firing pit. This technical area was abandoned in the late 1940s, and, in 1983, the remaining facilities were removed by LANL.<sup>52</sup>

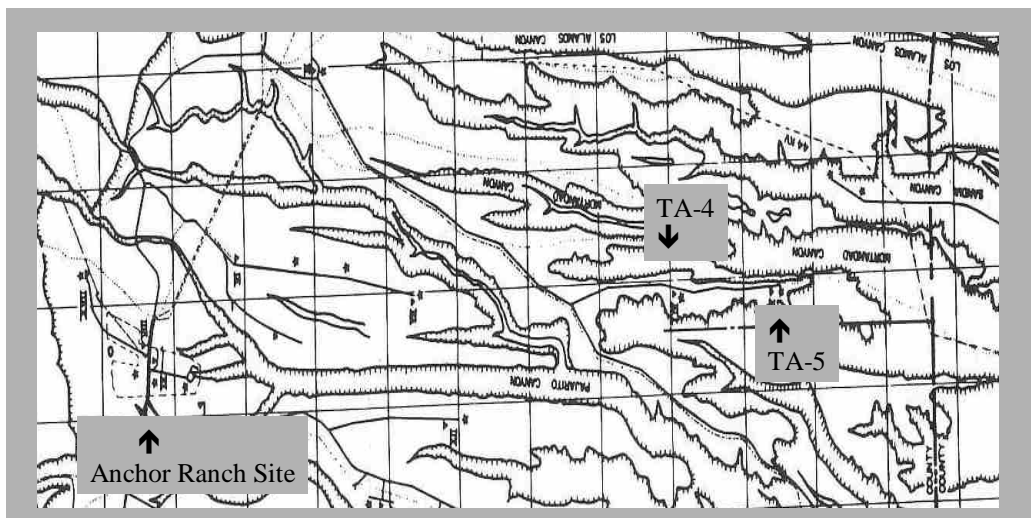

TA-4 and TA-5

### TA-5, Beta Site

TA-5 was another small firing site (located on the same mesa area as TA-4). Like TA-4, this technical area was also used to study implosions; however, the experiments were conducted using the electric method of observation. The technical area facilities included firing pits, a control building, a trimming building, and several explosives magazines.<sup>53</sup>

## TA-6, Two Mile Mesa Site (TM)



(LANL, IM-4 Photography)  
**TA-6 (1950)**

TA-6 was used to conduct research on detonators and for engineering tests of high explosives assemblies. The Two Mile Mesa Site was also used to develop methods for recovering active material (plutonium) in the event that the field-test of the implosion device failed. One of the most visible legacies of the testing at TA-6 is the large 200-ft-diameter concrete bowl recovery experiment. A complex of five wooden laboratory buildings and three smaller concrete buildings is also located at TA-6. The concrete buildings were originally used for indoor detonator testing.<sup>54</sup>



**The Concrete Bowl, TA-6**

(LANL, RRES-ECO)



**Early Laboratory Building, TA-6**

Standard detonator loading was moved to TA-6 in 1946. The importance of using electric detonators for multipoint detonation was apparent early in the development of the implosion device. The simultaneous firing of the detonators and the development of precision timing



systems were major technical problems to work out. Commercially available detonators were not adequate and many tests were conducted to develop models that would produce a small maximum time spread and the fewest failures. Two types of detonators were studied, the bridge wire and the spark gap, and tests were conducted using oscillographic methods and photographic observation. By the spring of 1945, thousands of detonators had been prepared for use in implosion field tests at the other Los Alamos testing areas.<sup>55</sup>

### **TA-7, Gomez Ranch Site or Two Mile Mesa (lower) Site**

Not much is known about the wartime activities conducted at a small storage and firing site identified as TA-7. This site is also referred to as Two Mile Mesa (lower) Site, and it is likely that high explosives and detonator firing tests conducted at TA-7 were similar to the firing tests conducted at TA-6 (Two Mile Mesa Site). The remains of a doghouse-sized hutment and several firing pits are located at this technical area; wooden hutments were used at TA-7 to cover partially assembled weapons.<sup>56</sup>



(LANL, RRES-ECO)

**TA-7 Firing Pit (right)  
and Hutment remains (above)**



(LANL, RRES-ECO)

**TA-8, Anchor Ranch Site West (AW) - G. S. (Gun Site)**



(LANL, IM-4 Photography)  
**TA-8 (1950)**

TA-8, historically known as Anchor West Site, was used during World War II to conduct gun tests in support of the gun device. The buildings at TA-8 included standard proving ground facilities that were designed with a central control area for explosives operations. Three concrete “bombproof” buildings were built into a ravine and were designed to be partially underground. Placing the buildings lower in the ravine allowed for gun emplacements to be positioned above the roof level of the control building. This unique proving ground layout lessened the hazards associated with using high-alloy tubes and with firing the tubes in free recoil.

**TA-8, Anchor Ranch,  
“Bombproof” Building**



(LANL, RRES-ECO)

The Anchor Ranch Proving Ground was completed and in active use by mid-September 1943. Special test guns were ordered from the Naval Gun Factory at the end of 1943 but were not ready until March 1944. During the 4-month waiting period, personnel at TA-8 conducted practice tests, perfected gun testing operations, and established high-speed photographic techniques for documenting the test data.<sup>57</sup> In May 1944, the first industrial-type radiograph was made at Anchor West Site using a medical X-ray unit. This early radiographic work was carried out in one of the log guesthouses that were originally part of the pre-war Anchor Ranch. In August 1944, these operations were moved to T Site, another early technical area (see TA-16 below). Beginning in the fall of 1945, TA-8 was used by Laboratory explosives personnel for high explosives research and development.<sup>58</sup>

### **TA-9, Anchor Ranch Site East (AE) - H. E. (High Explosives)**



(LANL, IM-4 Photography)  
**TA-9**

Some of the buildings at Anchor Ranch Site East were used to cast the high explosives used in the earliest implosion studies. A small casting room was in operation at the Anchor Ranch Site by October 1943. This facility produced very small castings of Pentolite. In early 1945, the TA-9 casting operations were replaced by the large-scale casting operations taking place at the newly completed S Site high explosives facilities.<sup>59</sup> Photographic studies of sphere implosions were also conducted at TA-9 using a flash X-ray source. This technical area was removed by the Laboratory in the 1960s.<sup>60</sup>

### **TA-10, Bayo Canyon Site**

The RaLa firing program located at TA-10 studied implosions using radiation from a radiolanthanum (RaLa) source. Testing started in remote Bayo Canyon in October 1944—the first RaLa trials were observed from sealed army tanks. These precautions were taken because of the lack of knowledge related to the extent and seriousness of the potential radioactive contamination that could result from the RaLa implosion tests. The contamination risks were not



as great as originally feared, and permanent facilities, including the RaLa Chemistry Building, were constructed at TA-10 by November 1944. Laboratory and support buildings in Bayo Canyon included assembly and inspection buildings, a personnel building, control buildings, and firing pads. Radiobarium from the Oak Ridge pile was used as the source of radioactivity for the test shots and prepared in the radiochemistry building at TA-10. During a typical experiment, the source would be inserted into a metal (usually Cadmium) shell and remotely detonated from one of the control buildings.

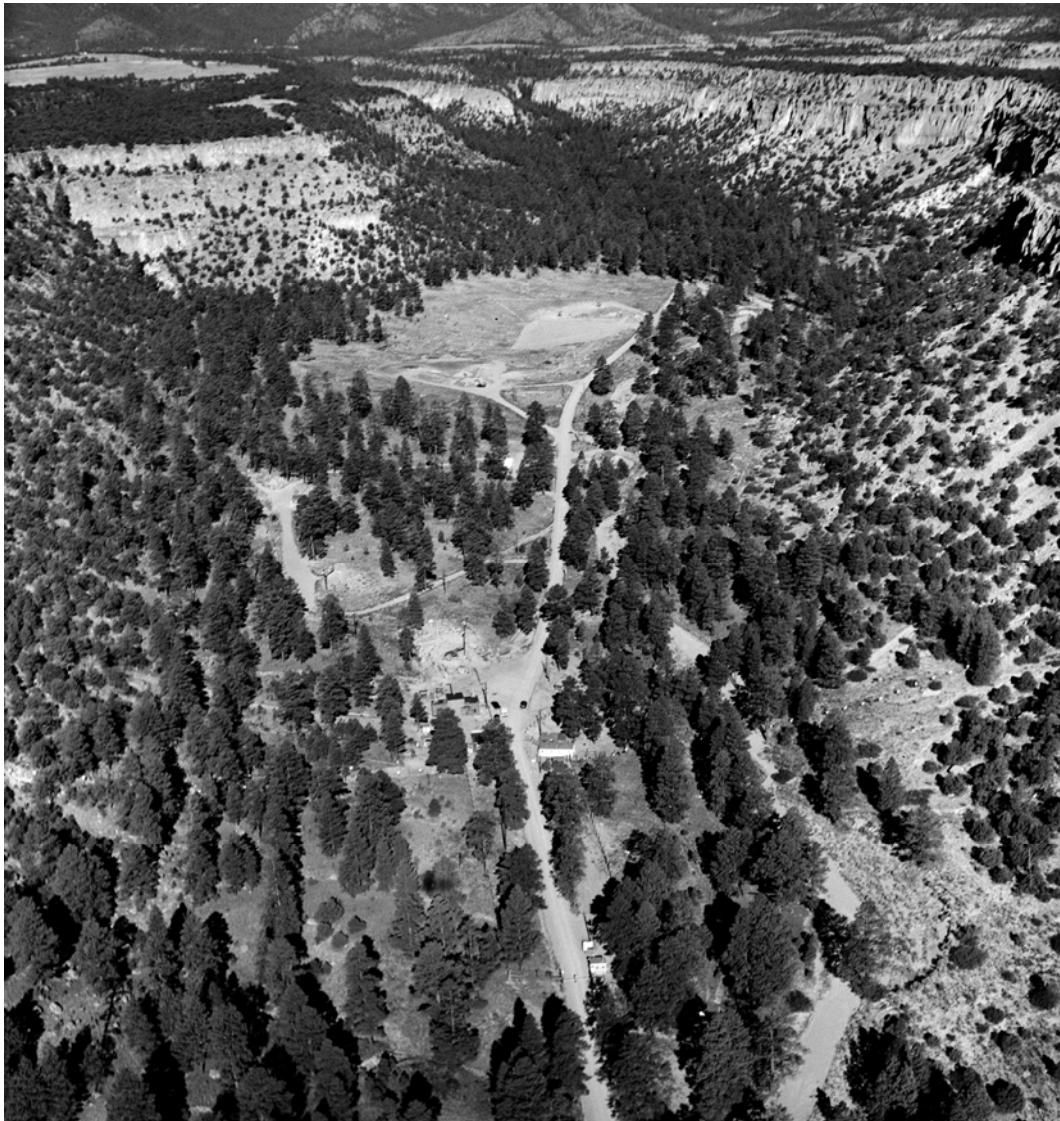

(LANL, IM-4 Photography)  
**TA-10 (1950)**



### TA-10 in Bayo Canyon

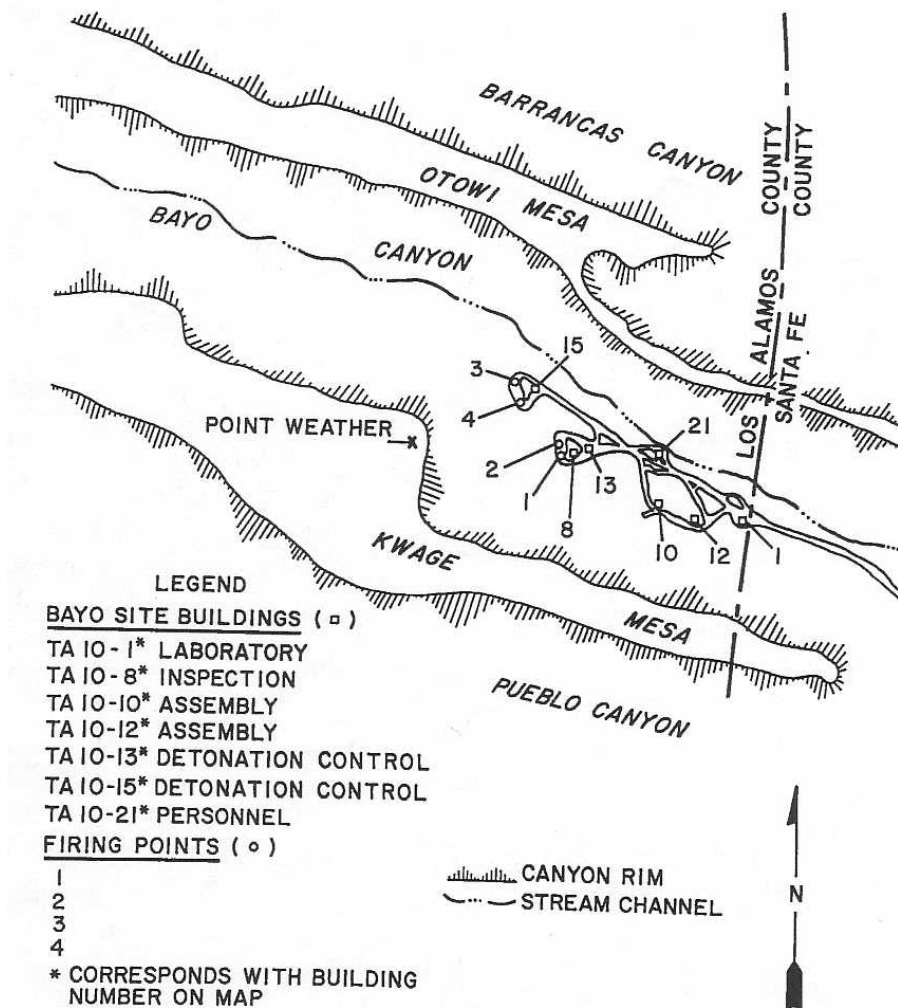

(from Ferenbaugh *et al.* 1982)

Electric detonators were used in the RaLa tests by February 1945 and the test results showed an immediate improvement. RaLa was the one experiment that most affected the final design of the implosion weapon. In fact, the first high-quality, high explosives lenses produced were allocated to the RaLa program in April 1945 so that the final design could be determined as soon as possible. RaLa ionization chambers were destroyed and the associated electronics were rendered unusable after each shot. The success of this program stemmed from Los Alamos's ability to conduct repeated shots regardless of the cost to construct and test the equipment. Several buildings at TA-10 were removed by the Laboratory in 1960. The rest of the technical area was either demolished or burned in 1963, and associated surface debris, utilities, and contaminated waste pits were removed.<sup>61</sup>

## TA-11, K Site



(LANL, IM-4 Photography)  
TA-11 (1950)

In early 1945, the betatron diagnostic method was used at TA-11 to collect data on the implosion of spheres. A 15-MeV betatron machine (gamma ray source) was used in conjunction with a cloud chamber and flash photography. The diagnostic procedure involved the detonation of a test implosion between two of the buildings, one housing the betatron equipment and the other housing the cloud chamber and associated recording equipment. A control building was also in use at K Site during the Manhattan Project years.<sup>62</sup> Other historical operations at TA-11 included photofission experiments and mortar and air gun firing activities. In the 1950s, mortars and air guns were used to conduct acceleration and impact tests using explosive systems contained in impact-resistant projectiles.<sup>63</sup>

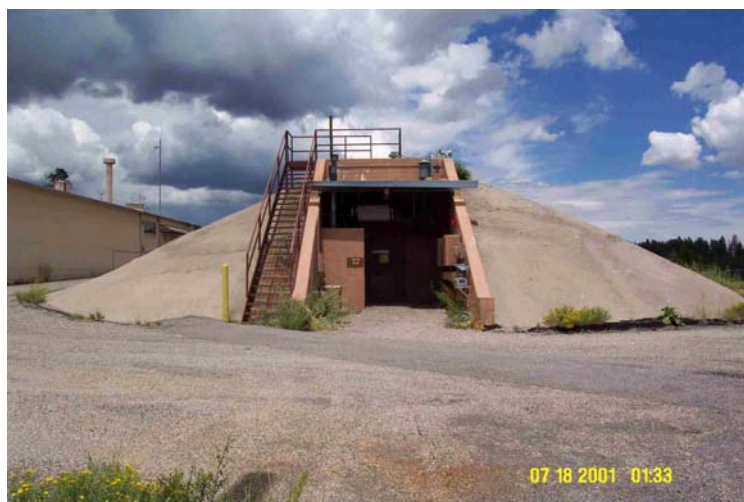

TA-11, Cloud Chamber

(LANL, RRES-ECO)

## TA-12, L Site

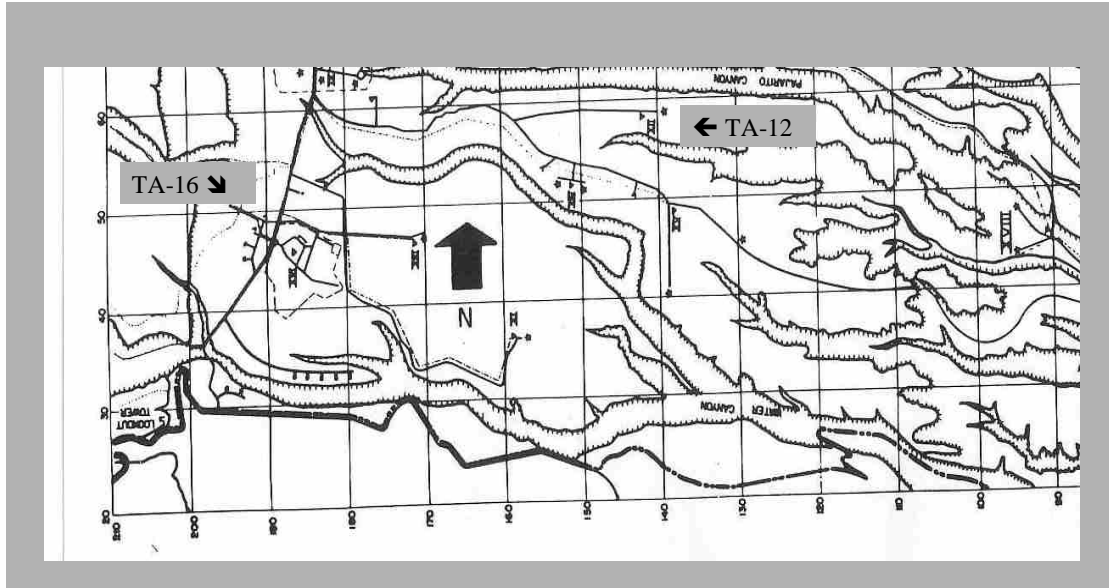

TA-12

The Terminal Observation Group (X-1B) used TA-12 as an explosives firing site. Site facilities included a hexagonal firing pit, a personnel shelter, a storage building, and two magazines. The firing pit was also used for recovery experiments. The site was abandoned in 1953, and, in 1960, most of the remaining structures were destroyed by the Laboratory.<sup>64</sup>

## TA-13, P Site



(LANL, IM-4 Photography)  
TA-13 (1950)

Flash X-ray studies of implosions were carried out at TA-13, using both the photographic and counter methods of observation. Flash X-ray was also used to study detonation waves related to the new lens designs. Key developments at P Site included devising protection for the X-ray equipment used near exploding charges and solving problems using the magnetic method combined with the X-ray method. Implosion research at this site also supported the later combining of the betatron (TA-11) and magnetic diagnostic methods. TA-13 was in operation by August 1944, and combined X-ray and magnetic records were obtained by late January 1945. Later in 1945, X-ray studies at TA-13 supported experimental work on initiators. Recovery experiments and an alpha-counting experiment were also carried out at this technical area.



(LANL RRES-ECO)  
**TA-13**

P Site was incorporated into TA-16 (S Site) sometime in the late 1940s or early 1950s. Three of the buildings associated with X-ray and later post-war high explosives research are still located at the former P Site area—a bermed control bunker, a concrete magazine, and a wooden building with an associated concrete bunker.<sup>65</sup>



## TA-14, Q Site



(LANL, IM-4 Photography)  
**TA-14 (1950)**

TA-14 was used to observe small-scale implosions. Cylinder implosions were studied using a rotating prism camera. The terminal observation method was also used at this technical area. Q Site facilities included a control building, high explosives magazines, firing chambers, and a shop and darkroom building.<sup>66</sup>



(LANL, RRES-ECO)  
**TA-14**

## TA-15, R Site



(LANL, IM-4 Photography)  
TA-15 (1950)

The flash photography method was used at TA-15 to study the implosion of cylinders. The TA-15 facilities included firing pits and control, firing, and observation buildings. Many of these early implosion-testing structures have been removed.<sup>67</sup>

## TA-16, Sawmill Site (S Site)

The high explosives components of the implosion design were developed, manufactured, and tested at TA-16 during World War II. Early activities at TA-16 supported the development of the first implosion-type atomic bombs: the “Trinity” device and the Nagasaki bomb (“Fat Man”). TA-16 was the principal site that manufactured high explosives castings and lenses to produce a spherical means of detonating an explosive charge—the lens served to bend the explosion wave as it went through the explosive. A symmetrical implosion was the key component in the critical assembly of the plutonium contained in the Trinity device and the “Fat Man” bomb.

The need for a large casting plant and widely separated test sites was apparent during the winter of 1943. The early S Site facilities included an office building, a steam plant, a casting house, storage magazines, and high explosives preparation buildings. Due to construction delays and difficulty procuring equipment, TA-16 operated only on a limited basis by May 1944 and did not begin steady operation until August of the same year.

Early S Site

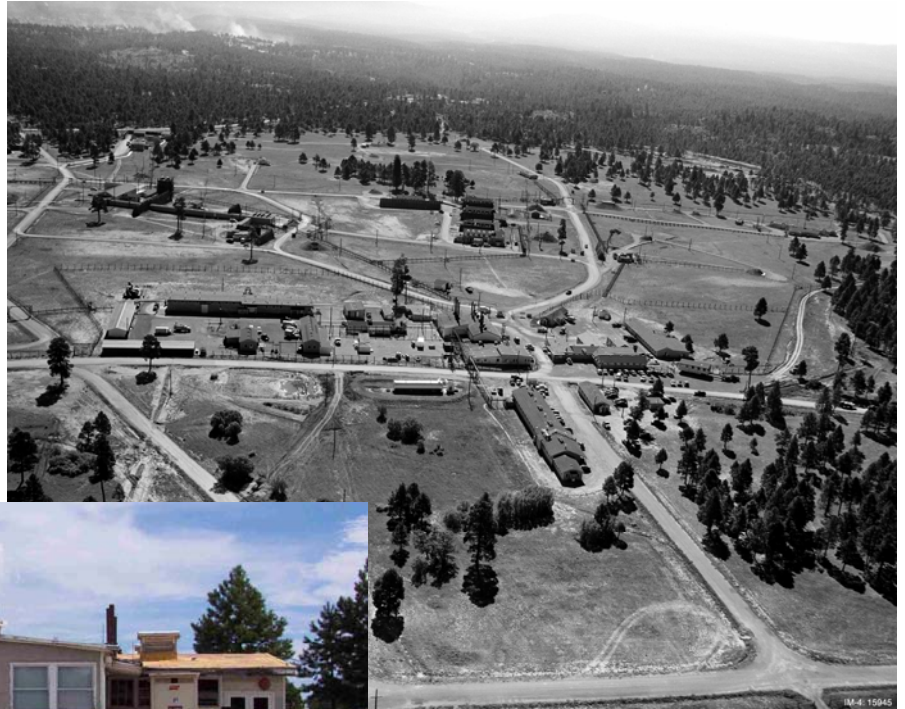

One of the remaining S Site buildings



(LANL, RRES-ECO)

(LANL, IM-4 Photography)

Project Y at Los Alamos underwent a massive reorganization in July 1944 after the discontinuation of the plutonium gun bomb design. As a result of this reorganization, implosion work was given a top priority and the development of high explosives at S Site became one of the most important wartime tasks. A major problem facing the scientists working with high explosives was that there were no existing methods for high explosives casting; the military's standards for explosives performance were well below what was needed to develop a symmetrical implosion. The technical problems were eventually overcome, and the S Site facilities produced about 20,000 usable castings over an 18-month period—over 100,000 pounds of high explosives were used per month during S Site's peak operation. Several types of explosive materials were used in the casting process: Composition B, Torpex, Pentolite, Baronal, and Baratol.<sup>68</sup>



TA-16 includes the locations of former Technical Areas 13, 24, and 25. TA-13 (P Site) was constructed in 1944 to conduct flash X-ray studies of the implosion of high explosives test devices. It consisted of an office and shop building, laboratory and test buildings, an experimental chamber, a magazine, and a storage building. By the 1950s, most of the buildings had been removed. The remaining buildings were absorbed into the TA-16 complex, and were renumbered TA-16-476, TA-16-477, and TA-16-478. These buildings were later used for high explosives machining studies. TA-24 (T Site) has been decommissioned. It was used for x-ray examination of high explosives charges during the 1940s. Explosives storage magazines and laboratories were part of the facility. TA-25 (V Site) was constructed in 1944 for experimental work in connection with special assemblies. In 1945, the site was altered and became part of TA-16 to allow process work on explosive charges. Structures at the site included an assembly bay, laboratory buildings, an equipment building, and a warehouse. A trial assembly of the Trinity device was conducted at TA-25 in 1945.<sup>69</sup>

**TA-17 (X Site)**

Never completed.

**TA-18, Pajarito Laboratory (PL)**



(LANL, IM-4 Photography)  
**TA-18 (circa 1950)**

The TA-18 area was the location of several different projects during the Manhattan Project years at Los Alamos. The Radioactivity Group first used Pajarito Canyon in mid-1943. This remote site was selected because of the need to work away from the high-radiation background levels being produced at the Main Technical Area. TA-18 also contained usable buildings associated with Ashley Pond's failed dude ranch, the Pajarito Club (abandoned in 1916). The Radioactivity Group used ionization chambers and amplifiers to study samples of plutonium and to determine counting rates from spontaneous fission. The work at TA-18 by Segrè and others led to the abandonment of the plutonium gun bomb design in July 1944.



(Photo Courtesy of the Los Alamos Historical Society)

**Pajarito Club**

Later in 1944, Pajarito Canyon was selected as a proving ground for the magnetic method of studying implosions. TA-18's "Battleship Buildings" (earth-covered bunkers) were used to conduct the implosion tests. Full-scale tests of high explosives assemblies were also conducted at this technical area. This field-testing work was abandoned before the end of 1945.

**TA-18, Battleship Building**



(LANL, RRES-ECO)

Pajarito Laboratory became Los Alamos's main site for critical assembly work in April 1946. The decision to conduct critical assembly work at TA-18 was directly related to Harry Daghlian's death from radiation exposure at Omega Site in 1945. At Pajarito Site, critical assemblies were still operated by hand until Louis Slotin's death in May 1946; like Daghlian, Slotin received a lethal radiation exposure from a critical assembly experiment. After this second fatality, all critical assembly operations were halted until special remote operation facilities were constructed at TA-18.<sup>70</sup>

### **TA-19, East Gate Laboratory**



**TA-19 (1950)**  
(LANL, IM-4 Photography)

TA-19 was specifically established by the Radioactivity Group to study spontaneous fission measurements. This same group had used the abandoned Pajarito Club buildings in Pajarito Canyon to study the properties of plutonium. The laboratory building, hutment, and Military Police post associated with this technical area were removed after 1962.<sup>71</sup>

### **TA-20, Sandia Canyon Site**

TA-20 was primarily used as a proving ground for initiators. Nuclear weapons rely on devices, known as "initiators," to supply a source of neutrons that will quickly enhance the chain reaction at exactly the right moment. During the Manhattan Project at Los Alamos, polonium, a powerful source of alpha particles, was used in conjunction with beryllium in the first initiators.<sup>72</sup> The Initiator Group working at the Sandia Canyon Site focused exclusively on the development of this bomb component. This attention to one task made the work at TA-20 different from the work conducted at the other field-testing areas using a diversity of approaches. TA-20 was abandoned around 1947.<sup>73</sup>

## TA-21, DP Site



**DP West (1950)**



**DP East (1950)**

(LANL, IM-4 Photography)

TA-21 was the center of chemical and metallurgical production at Los Alamos for many years. Research and development activities conducted at this technical area included plutonium and uranium processing at DP West and polonium processing at DP East. The importance of this technical area comes from its contributions to weapons-related research and development after the end of World War II—the first plutonium facilities at DP Site were not occupied until the summer of 1945. Fissile material used in the Trinity device and in the “Little Boy” and “Fat Man” bombs was not processed at DP Site; rather, the final processing of the uranium and plutonium used in the wartime devices was completed in buildings located at the Main Technical Area.<sup>74</sup>



(LANL, IM-4 Photography)  
**Early TA-21 (DP Site)**



## TA-22, Trap Door Site (TD Site)



(LANL, IM-4 Photography)  
**TA-22 (1950)**

TA-22 was primarily used for detonator research and development. Some test assembly work was also conducted at this technical area, and the high explosives components of the “Fat Man” bomb were assembled in a large Quonset hut.<sup>75</sup>



(LANL, RRES-ECO)  
**Quonset Hut at TA-22**

### **TA-23, NU Site**

TA-23 was used for implosion studies. Observations of cylinder collapse were made using a rotating prism camera. Terminal observations of implosions were conducted in a pit facility at TA-23. Facilities at this small technical area included a concrete camera building, a trimming building, and two magazines. The site was torn down sometime in the late 1940s or early 1950s. It was located on the eastern side of present-day TA-9.<sup>76</sup>

### **TA-24, T Site**



(LANL, IM-4 Photography)  
**TA-24 (1950)**

Facilities at TA-24 were used to perform X-ray inspections of finished explosive castings. Inspection techniques used at TA-24 included radiography and electron microscopy. The laboratory building, explosives magazines, and associated support buildings were removed in the 1960s.<sup>77</sup>

### **TA-25, V Site**

Mockups of both the implosion and gun “gadgets” were tested at TA-25. This technical area, now part of TA-16 (S Site) was used to conduct handling (shake) tests and to investigate the possibility that heating equipment might be needed in the bomb bays of the B-29s used to drop first atom bombs. In addition to the mockup testing, V Site was used to assemble the high explosives components of the Trinity device.<sup>78</sup>





(LANL, IM-4 Photography)  
**V Site and Implosion Gadget**



(LANL, RRES-ECO)  
**V Site Buildings (TA-25)**

## TA-26, D Site



(LANL, IM-4 Photography)  
TA-26 (1950)

TA-26 was located along the main road to Los Alamos, east of the airport area. Facilities included a concrete vault and several standard guard towers. The site has been removed.<sup>79</sup>

## TA-27, Gamma Site

TA-27 was used for testing complete weapon assemblies against bullet impact. The facilities at this technical area included three firing points and a control building. Gamma Site was located just east of Pajarito Canyon Site (TA-18) in the bottom of Pajarito Canyon. Any remaining structures were removed by the Laboratory in 1966.<sup>80</sup>

## TA-28, Magazine Area “A”

TA-28 is an ordnance storage area with five small magazine buildings.<sup>81</sup>

## TA-29, Magazine Area “B”

TA-29 was abandoned in 1957. The technical area facilities included two magazine buildings and associated earth barricades.<sup>82</sup>

### **TA-30, Electronics Test Area**

The exact use of this site is unknown although it is identified as an electronics testing area. The only Laboratory facility documented at this site was a 16 ft by 16 ft frame building. The building was demolished in 1946 when TA-30 was formally removed.<sup>83</sup>

### **TA-31, East Receiving Yard**

TA-31 was originally set up as a receiving yard for security reasons. Navajo Freight Line trucks were unloaded at TA-31 so that they would not have to enter the Main Technical Area. TA-31's facilities consisted of a receiving dock on pilings, six warehouses, and a drum storage area. Now part of the Los Alamos "Eastern Area" housing, the yard was located between the intersection of Canyon and East Roads, to the west, and the Airport Road turnoff, to the east.<sup>84</sup>

### **TA-32, Medical Research Laboratory**



**Figure 50. TA-32 (1950)**  
(LANL, IM-4 Photography)

TA-32 was the site of the predecessor facilities to TA-43, the present Health Research Laboratory. TA-32 was located in downtown Los Alamos near the Los Alamos County warehouses south of Trinity Drive and west of DP Road. The facilities included three laboratories, an office building, and two other buildings. Research conducted at TA-32 focused on the biological effects of both external irradiation and the inhalation and ingestion of radionuclides.

### **TA-44, Los Angeles Shop**

The Los Angeles Shop was located in Los Angeles, California, on the corner of Barranca Street and North Avenue. TA-44 was an experimental machine shop that provided custom-made,

small- or medium-sized ferrous and nonferrous parts. The materials used were nonclassified and nonhazardous. The original shop building was abandoned in 1958 and was later occupied by a ladder-making company.<sup>85</sup>

#### **TA-47, Bruns Railhead (BR Site)**

TA-47 was the receiving point for material shipped to Los Alamos during World War II. The railhead was situated near the present-day Greer Garson Theatre on the campus of the College of Santa Fe in Santa Fe, New Mexico, and was abandoned by the Laboratory in 1959. Several wooden buildings are still located in the area of the railhead. These buildings may be associated with the former Bruns Hospital, located at the same site.<sup>86</sup>

### Section 3—Property Summaries and Eligibility Recommendations

All 51 remaining Manhattan Project properties were visited and evaluated for National Register of Historic Places eligibility (see Appendix A for maps and specific property information).

**Eligible: 44**

The 44 Register-eligible properties were assessed in terms of their potential for preservation and public interpretation, with the most historically significant properties being identified for permanent retention. Those eligible properties not slated for preservation will be evaluated on a case-by-case basis in the event they are scheduled for decontamination and decommissioning. Eleven of the properties had previously been declared eligible for the Register in earlier correspondence with the State Historic Preservation Officer; one had been reviewed but no determination had been made.

**Not Eligible: 7**

Two of the buildings had been previously declared eligible for the Register: TA-16-16 and TA-21-14. However, based upon the results of the multiple property evaluation, these buildings clearly do not retain the same level of integrity or significance as their historical counterparts and should not be considered eligible for the Register.

TA-BLDG	BLDG NAME	Date Built	Current NRHP Eligibility Status	Associated Theme/ Subtheme	Eligibility Recommendation	Proposed Management Action
3-478	Storage Shed	1945	Not Reviewed	?	Not Eligible (portable support bldg.)	N/A
3-479	Storage Shed	1946	Not Reviewed	?	Not Eligible (portable support bldg.)	N/A
6-1	Laboratory & Office Bldg	1944?	Not Reviewed	Detonators	Eligible, A	None at present
6-2	Compressor Bldg	1944?	Not Reviewed	Detonators	Eligible, A	None at present
6-3	Fabrication Bldg	1944?	Not Reviewed	Detonators	Eligible, A	None at present
6-5	Laboratory Bldg	1945?	Not Reviewed	Detonators	Eligible, A	None at present
6-6	Laboratory & Office Bldg	1945?	Not Reviewed	Detonators	Eligible, A	None at present
6-7	Laboratory Bldg	1945?	Not Reviewed	Detonators	Eligible, A&C	None at present
6-8	Laboratory Bldg	1945?	Not Reviewed	Detonators	Eligible, A&C	None at present
6-9	Firing Chamber	1945?	Not Reviewed	Detonators	Eligible, A&C	None at present

<b>TA- BLDG</b>	<b>BLDG NAME</b>	<b>Date Built</b>	<b>Current NRHP Eligibility Status</b>	<b>Associated Theme/ Subtheme</b>	<b>Eligibility Recommendation</b>	<b>Proposed Management Action</b>
6-37 (LA 25284)	Concrete Bowl/Experimental Area	1944	Eligible	Implosion (Pu Recovery/ Atomic Bomb)	Eligible, A&C	Retain
TA-6 (LA 131234 C)	Bomb Cover	WWII era	Eligible	Stockpile	Eligible, A	Retain
TA-7 (LA 131235 A, B, and C)	Firing Sites	WWII era	Un- determined (SHPO)	High Explosives and Detonators	Eligible, A	None at present
8-1	Laboratory & Shop	1943	Not Reviewed	Gun Device (Atomic Bomb)	Eligible, A&C	Retain
8-2	Shop & Storage Bldg	1943	Not Reviewed	Gun Device (Atomic Bomb)	Eligible, A&C	Retain
8-3	Laboratory	1943	Not Reviewed	Gun Device (Atomic Bomb)	Eligible, A&C	Retain
11-1	Control Laboratory	1944	Not Reviewed	Implosion (Atomic Bomb)	Eligible, A	None at present
11-2	Betatron Bldg	1944	Not Reviewed	Implosion (Atomic Bomb)	Eligible, A&C	None at present
11-3	Cloud Chamber Bldg	1944	Not Reviewed	Implosion (Atomic Bomb)	Eligible, A&C	None at present
11-4	Shop/Implosion Imaging	1944	Not Reviewed	Implosion (Atomic Bomb)	Eligible, A	None at present
12-4	Firing Pit	1945	Not Reviewed	Implosion/ Recovery (Atomic Bomb)	Eligible, A	None at present
14-6	Shop and Dark Room	1944	Not Reviewed	Implosion (Atomic Bomb)	Eligible, A	None at present



<b>TA- BLDG</b>	<b>BLDG NAME</b>	<b>Date Built</b>	<b>Current NRHP Eligibility Status</b>	<b>Associated Theme</b>	<b>Eligibility Recommendation</b>	<b>Proposed Management Action</b>
<b>15-23</b>	<b>Laboratory and Control Bldg</b>	1945	Eligible	Initiator Research and Explosives Testing	Eligible, A	None at present
<b>16-7</b>	<b>Steam Plant/Machine Shop</b>	1944	Not Reviewed	High Explosives	Not Eligible (extensive remodeling)	N/A
<b>16-16</b>	<b>Cafeteria (now Office)</b>	1945	Eligible	High Explosives – Admin. Support	Not Eligible (extensive remodeling)	N/A
<b>16-54</b>	<b>Grinding Bldg</b>	1946	Eligible	High Explosives	Eligible, A	None at present
<b>16-58</b>	<b>Magazine</b>	1944	Not Reviewed	High Explosives	Eligible, A	None at present
<b>16-476 (former 13-2)</b>	<b>Laboratory/Test Bldg</b>	1944	Not Reviewed	Implosion (Atomic Bomb)	Eligible, A&C	None at present
<b>16-477 (former 13-3)</b>	<b>Laboratory/Test Bldg</b>	1944	Not Reviewed	Implosion (Atomic Bomb)	Eligible, A&C	None at present
<b>16-478 (former 13-4)</b>	<b>Laboratory and Machine Test Bldg</b>	1944	Not Reviewed	Implosion (Atomic Bomb)	Eligible, A&C	None at present
<b>16-516</b>	<b>Process/Inspection Bldg</b>	1944	Eligible	High Explosives Assembly (Trinity, Gun, and Implosion Devices)	Eligible, A	Retain
<b>16-517</b>	<b>Process/Inspection/Equipment Bldg</b>	1944	Eligible	High Explosives (Trinity, Gun, and Implosion Devices)	Eligible, A	Retain
<b>18-1</b>	<b>Laboratory/Staging Area ("Slotin Bldg")</b>	1946	Not Reviewed	Implosion and Critical Assembly and BioMed/ Health Physics	Eligible, A	Retain

<b>TA- BLDG</b>	<b>BLDG NAME</b>	<b>Date Built</b>	<b>Current NRHP Eligibility Status</b>	<b>Associated Theme</b>	<b>Eligibility Recommendation</b>	<b>Proposed Management Action</b>
18-2	Control Bldg (“ Battleship Bldg ”)	1944	Not Reviewed	Implosion (Atomic Bomb)	Eligible, A&C	None at present
18-5	Control Bldg (“ Battleship Bldg ”)	1944	Not Reviewed	Implosion (Atomic Bomb)	Eligible, A	None at present
18-29	Pond Cabin	1914	Eligible (State Register)	Early Los Alamos (pre-Lab), and Pu and Implosion, R&D	Eligible, A (greatest significance relates to Early Los Alamos)	Retain
21-1	Office/Vault Bldg	1945	Not Eligible	Pu Production (Early Stockpile)	Not Eligible (extensive remodeling)	N/A
21-2	Laboratory Bldg	1945	Eligible	Pu Production (Early Stockpile), BioMed/ Health Physics	Eligible, A	None at present
21-5	Laboratory Bldg	1945	Eligible	Pu Production (Early Stockpile)	Eligible, A	None at present
21-14	Diesel Power Plant	1946	Eligible	Pu Production (Support Bldg.)	Not Eligible (not significant, poor integrity)	N/A
21-21	Storage Vault	1946	Eligible	Pu Production (Early Stockpile)	Eligible, A	None at present
21-42	Pump House	1945	Not Eligible	Pu/Initiator (Support Bldg.)	Not Eligible (not significant)	None at present
21-152	Laboratory Bldg	1945	Eligible	Initiators/ Nuclear Propulsion/ Tritium	Eligible, A	None at present
21-166	Equipment Bldg	1945	Eligible	Initiators/ Nuclear Propulsion/ Tritium	Eligible, A (attached to 21-152)	None at present

<b>TA- BLDG</b>	<b>BLDG NAME</b>	<b>Date Built</b>	<b>Current NRHP Eligibility Status</b>	<b>Associated Theme</b>	<b>Eligibility Recommendation</b>	<b>Proposed Management Action</b>
<b>21-167</b>	<b>Equipment Bldg</b>	1945	Eligible	Initiators/ Nuclear Propulsion/ Tritium	Eligible, A (attached to 21-152)	None at present
<b>22-1</b>	<b>Assembly and Loading Bldg</b>	1945	Eligible	Fat Man Assembly/ Implosion	Eligible, A	Retain
<b>28-1</b>	<b>Magazine</b>	1944?	Not Reviewed	High Explosives (Atomic Bomb)	Eligible*, A	None at present
<b>28-2</b>	<b>Magazine</b>	1944?	Not Reviewed	High Explosives (Atomic Bomb)	Eligible*, A	None at present
<b>28-3</b>	<b>Magazine</b>	1944?	Not Reviewed	High Explosives (Atomic Bomb)	Eligible*, A	None at present
<b>28-4</b>	<b>Magazine</b>	1944?	Not Reviewed	High Explosives (Atomic Bomb)	Eligible*, A	None at present
<b>28-5</b>	<b>Magazine</b>	1944?	Not Reviewed	High Explosives (Atomic Bomb)	Eligible*, A	None at present

\* Identical properties: any mitigation or documentation should focus on only the best example of the five.

## **Appendix A—Location Maps, Photographs, Descriptions, and Drawings of Remaining Manhattan Project Buildings and Structures (LANL)**

Prepared by

**Sheila McCarthy**, Historical Architect, Benchmark Consulting Group  
**Ken Towery**, Architect, LANL Site and Project Planning Group  
**John Ronquillo**, Consulting Engineer, Sigma Science, Inc.  
**Ellen D. McGehee**, Cultural Resource Manager, LANL Ecology Group  
**Kari L. M. Garcia**, Cultural Resource Manager, LANL Ecology Group

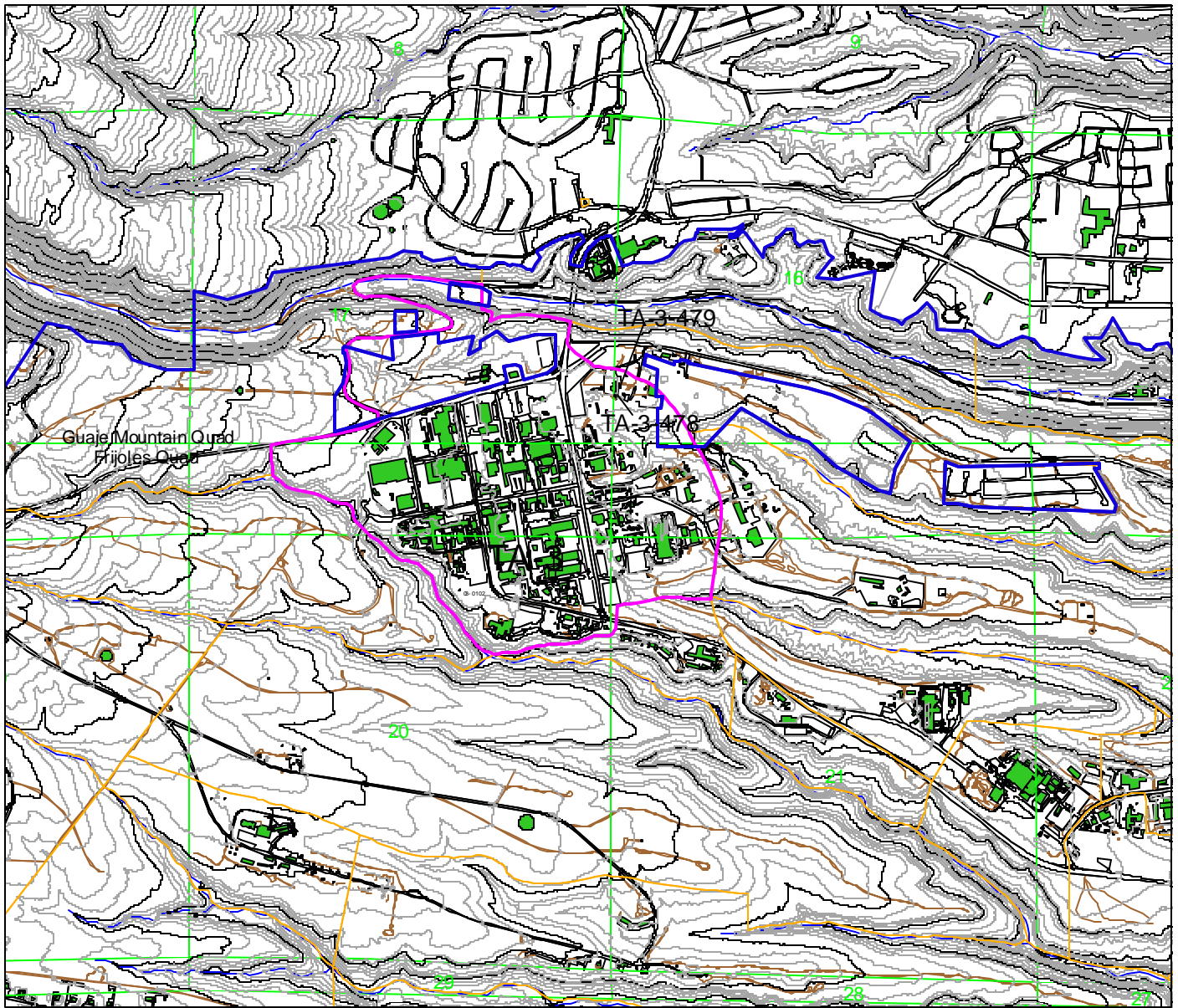

# Los Alamos National Laboratory

Cultural Resources Management Team  
RRES-ECO Ecology Group

1:24000

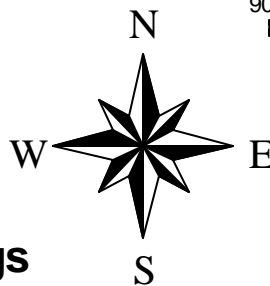
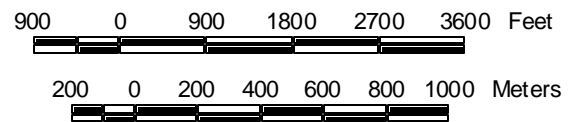

## Manhattan Project Buildings

TA-3

- Manhattan Project Buildings
- Los Alamos National Laboratory
- Tech Area 3
- Tech Areas
- 20 Foot Contours
- 100 Foot Contours
- Drainage
- Township, Section, Range
- USGS 7.5 Minute Quad
- Roads
- Roaddirt
- Parkpave
- Parkdirt
- Buildings/Structures

Map 2



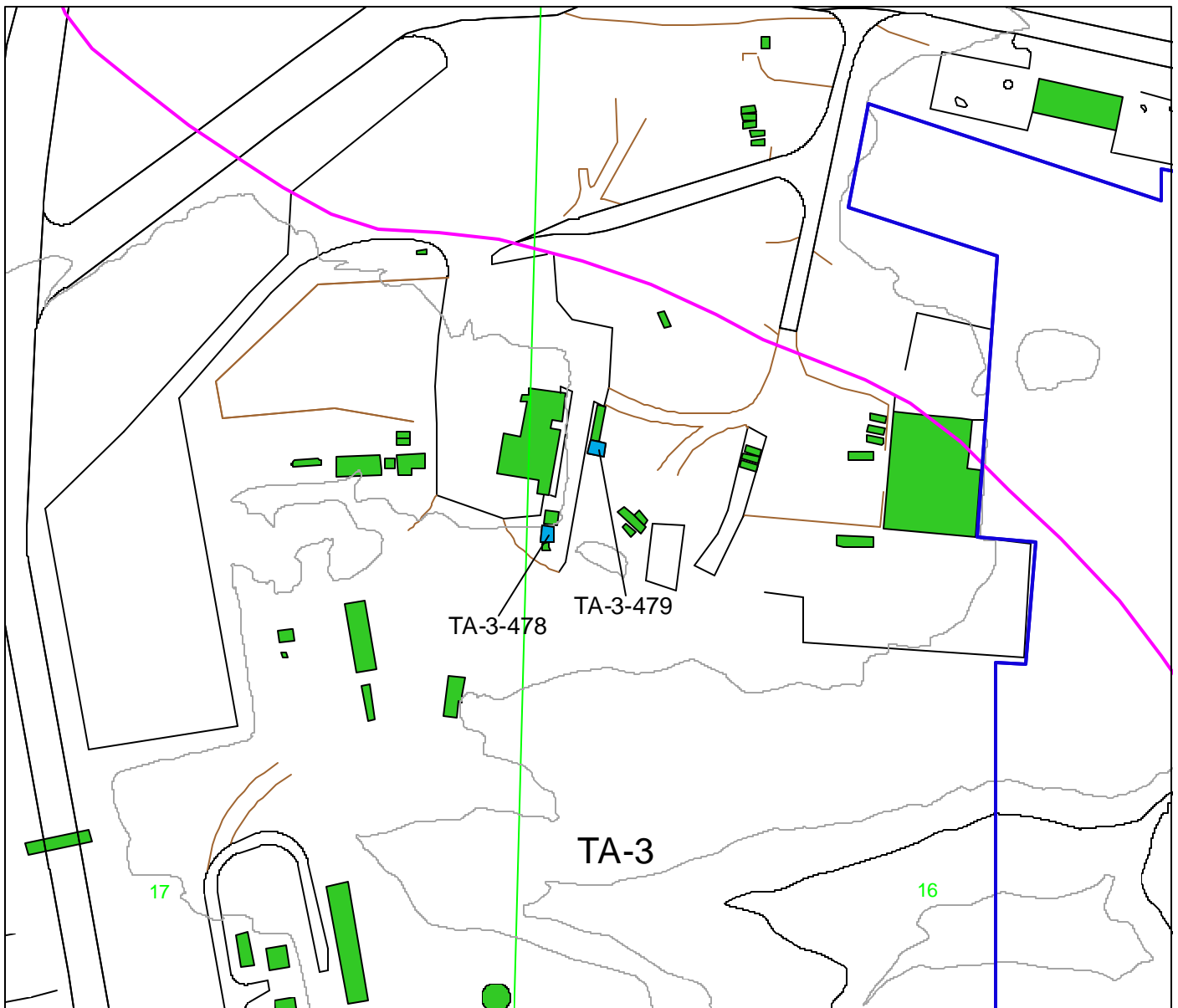

**Los Alamos National Laboratory**  
 Cultural Resources Management Team  
 RRES-ECO Ecology Group

1:2300

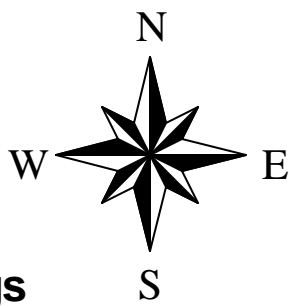
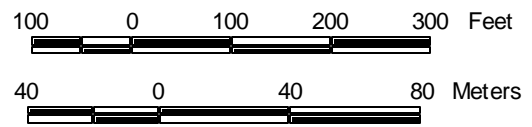

**Manhattan Project Buildings**

**TA-3 Closeup**

- Manhattan Project Buildings
- Los Alamos National Laboratory
- Tech Area 3
- Tech Areas
- 20 Foot Contours
- 100 Foot Contours
- Drainage
- Township, Section, Range
- USGS 7.5 Minute Quad
- Roads
- Road dirt
- Park pave
- Park dirt
- Buildings/Structures

Map 3



TA-3-478

**Original Function:** Storage Shed  
**Current Function:** Storage Shed  
**Historical Significance:** None

**Date Constructed:** 1945  
**Associated Theme:** ?  
**Eligible?:** No

**Description** (no drawings available):

TA-3-478 was built in 1945 and appears to have been used exclusively for storage. This small portable shed, a wood-frame structure, is approximately 12 ft by 16 ft in size. It has a low slope roof with multiple layers of roofing material, the latest being granular-impregnated roll roofing. Exposed joist ends and fascia boards appear to be of original material. The original wall frame is 2x4 frame with 1x6 sheathing. The exterior has recently been covered with a plywood product similar to T-111. The structure currently sits on steel skids that were probably added during one of its relocation moves. There are no apparent window openings, although they could have been covered over when the siding material was added. There is one door on the west elevation.



TA-3-479

**Original Function:** Storage Shed  
**Current Function:** Storage Shed  
**Historical Significance:** None

**Date Constructed:** 1946  
**Associated Theme:** ?  
**Eligible?:** No

**Description** (no drawings available):

TA-3-479 is a small storage shed. Although designed for temporary use (it is typical of military temporary construction), the shed is still being used for storage. The building is a wood structure; original materials are visible and unaltered. The foundation is wood with a wood-frame floor, walls, and roof. The roof is low slope with multiple roofing layers visible. The exterior walls are 2x4 frame with asphalt-impregnated paper and asbestos-containing lap shingles. The front elevation has a small overhang and a porch about five ft wide. The rear elevation also has an overhang extended by the roof rafters. The floor is elevated approximately two ft above grade. The front door appears to be the original double wood-panel door with two-over-two window lights (panes of glass). The other three elevations each contain one wood-frame window with fixed three-over-three window lights.

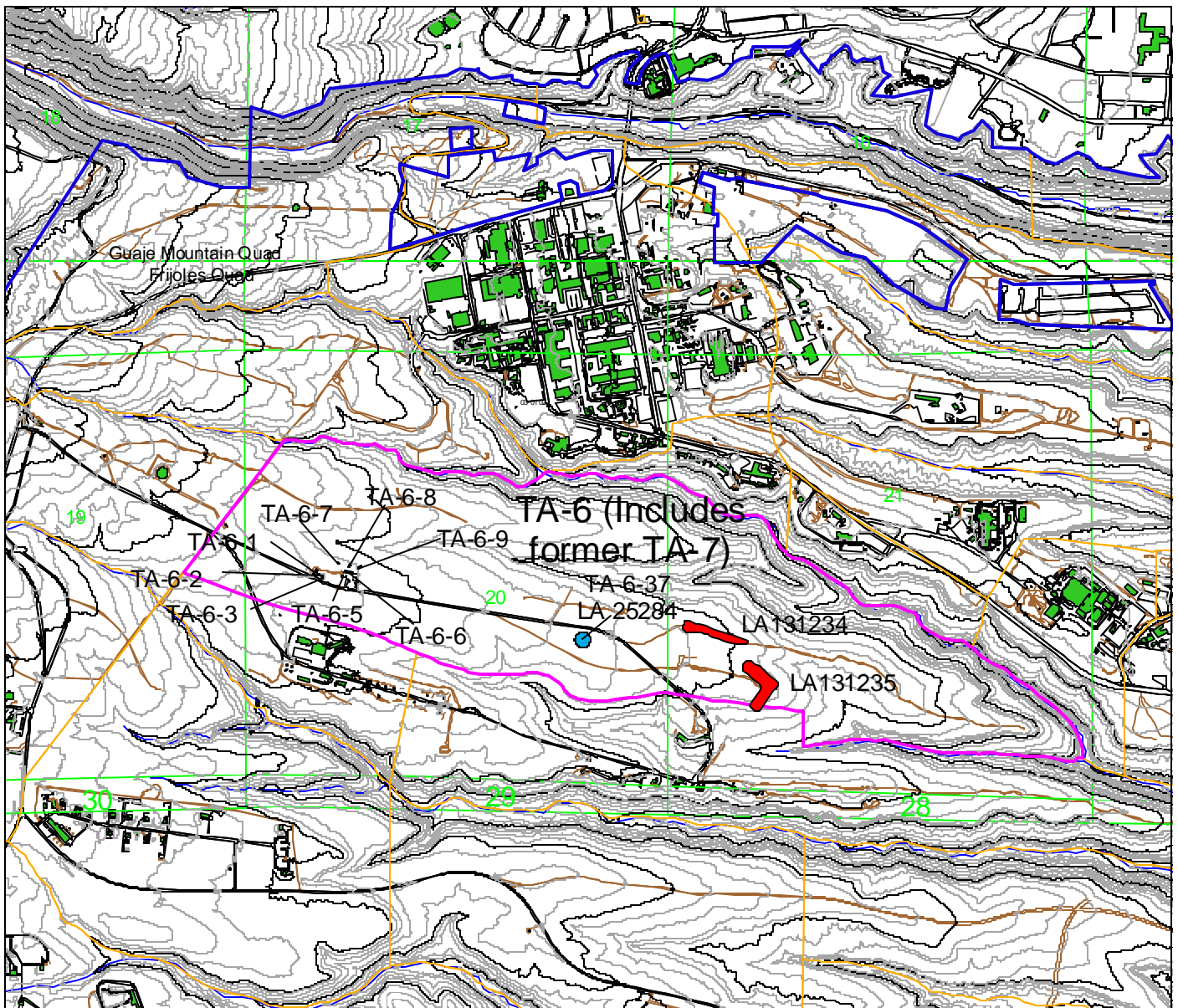

**Los Alamos National Laboratory**  
 Cultural Resources Management Team  
 RRES-ECO Ecology Group

1:24000

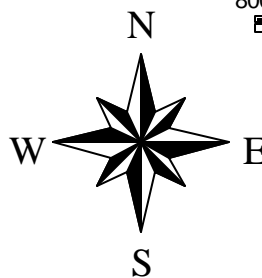
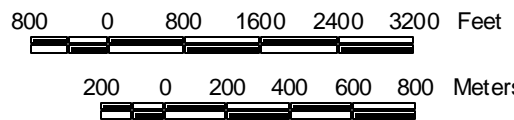

**Manhattan Project Buildings**

**TA-6  
 (Including Former TA-7)**

- Manhattan Project Structure Remains
- Manhattan Project Buildings
- Los Alamos National Laboratory
- Tech Area 6
- Tech Areas
- 20 Foot Contours
- 100 Foot Contours
- Drainage
- Township, Section, Range
- USGS 7.5 Minute Quad
- Roads
- Road/dirt
- Park/pave
- Park/dirt
- Buildings/Structures

Map 4

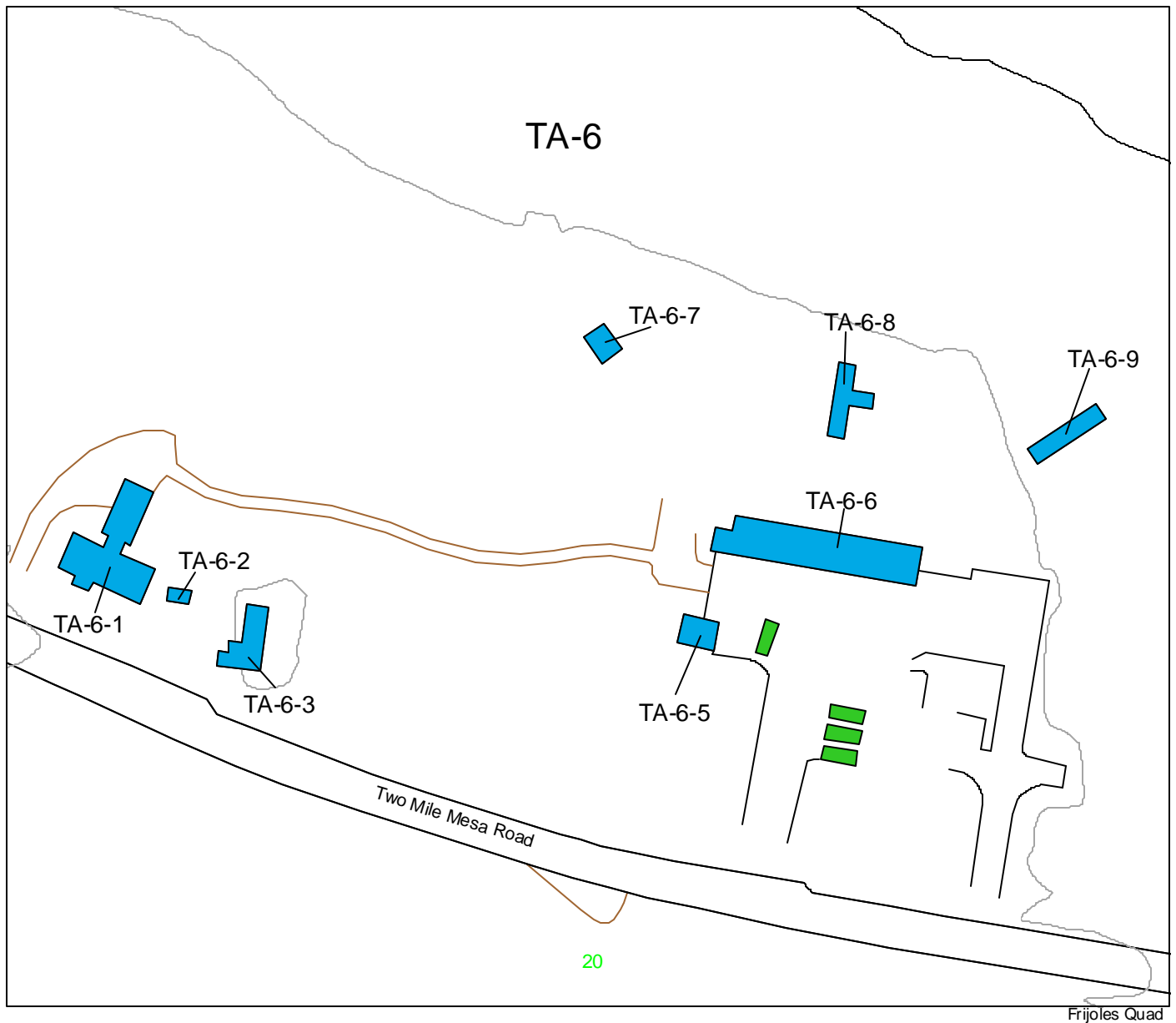

Frijoles Quad

# Los Alamos National Laboratory

Cultural Resources Management Team  
RRES-ECO Ecology Group

1:1100

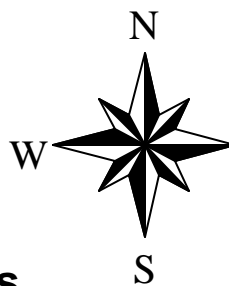
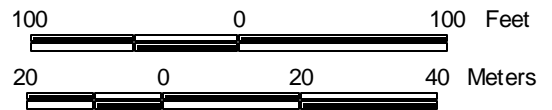

## Manhattan Project Buildings

## Western TA-6 Closeup

- Manhattan Project Structures
- Manhattan Project Buildings
- Los Alamos National Laboratory
- Tech Area 6
- Tech Areas
- 20 Foot Contours
- 100 Foot Contours
- ↘ Drainage
- ↘ Township, Section, Range
- USGS 7.5 Minute Quad
- Roads
- Road/dirt
- Park/pave
- Park/dirt
- Buildings/Structures

Map 5



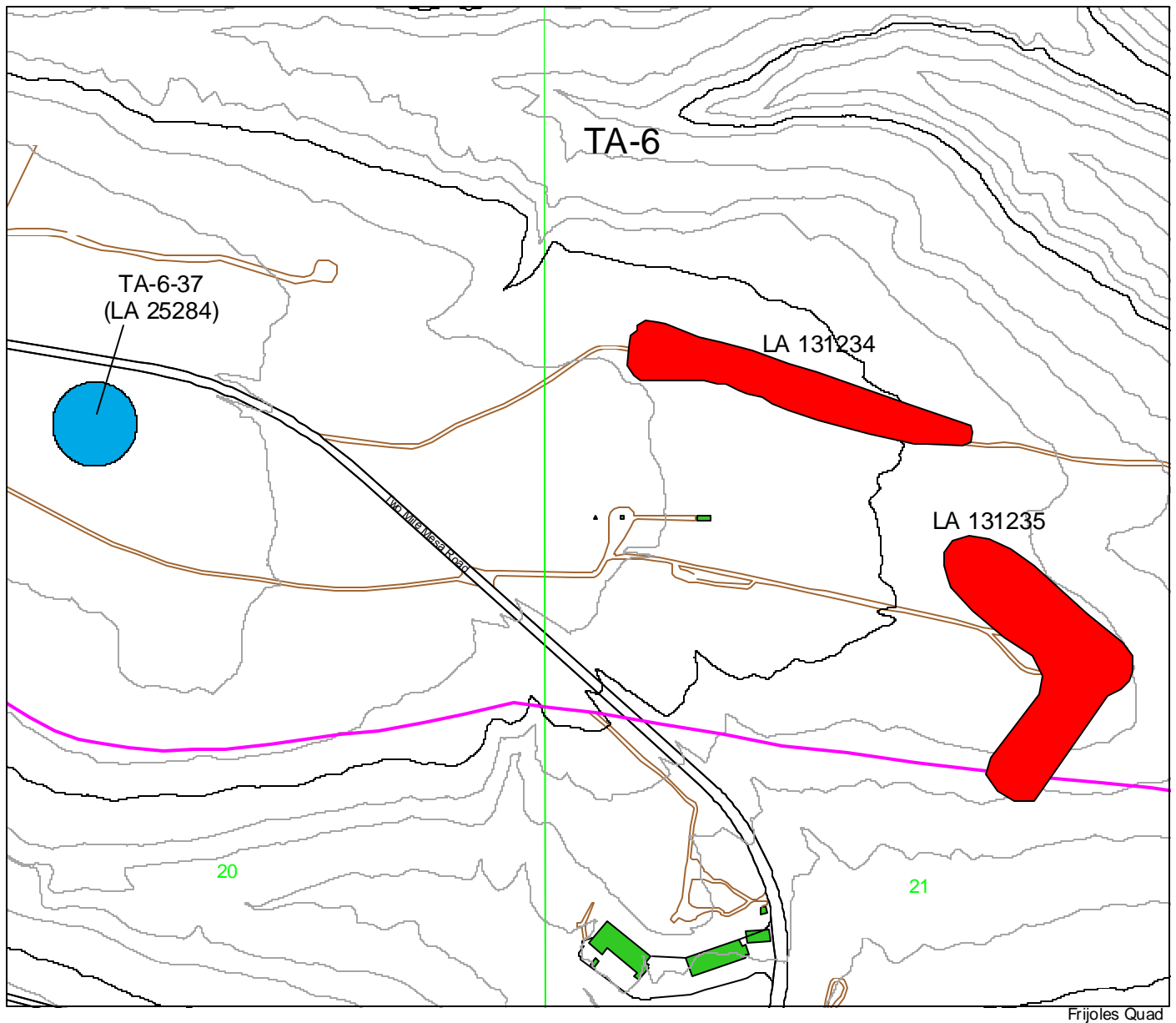

Frijoles Quad

**Los Alamos National Laboratory**  
 Cultural Resources Management Team  
 RRES-ECO Ecology Group

1:4500

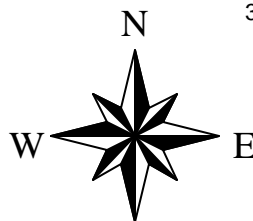

**Manhattan Project Buildings and Structures**

**Eastern TA-6 Closeup**

- Manhattan Project Structures
- Manhattan Project Buildings
- Los Alamos National Laboratory
- Tech Area 6
- Tech Areas
- 20 Foot Contours
- 100 Foot Contours
- Drainage
- Township, Section, Range
- USGS 7.5 Minute Quad
- Roads
- Road/dirt
- Park/pave
- Park/dirt
- Buildings/Structures

Map 6



### TA-6-1

**Original Function:** Laboratory and Office  
**Current Function:** Vacant  
**Historical Significance:** Detonator research and development in support of implosion device.

**Date Constructed:** 1944?  
**Associated Theme:** Detonators  
**Eligible?:** Yes – “A”

#### **Description:**

TA-6-1 is made up of two barrack-type structures set perpendicular to each other and connected by a small corridor. The structures are wood-frame construction with a low slope roof, asbestos wall shingles, and built up and composite roofing material. Corrugated metal siding has been added up to the wainscot level on the exterior of the office wing and connecting corridor. Numerous windows are visible in the perimeter walls. The windows are wood sash with three-over-three window lights. The foundation is wood post and beam and is elevated about three ft. Wood stairs and platforms provide elevation rise to the floor level. The front door area is covered by a wood porch and canopy, which provides weather protection and some exterior material storage. The two main entry doors are wood double doors with two-over-two window lights.

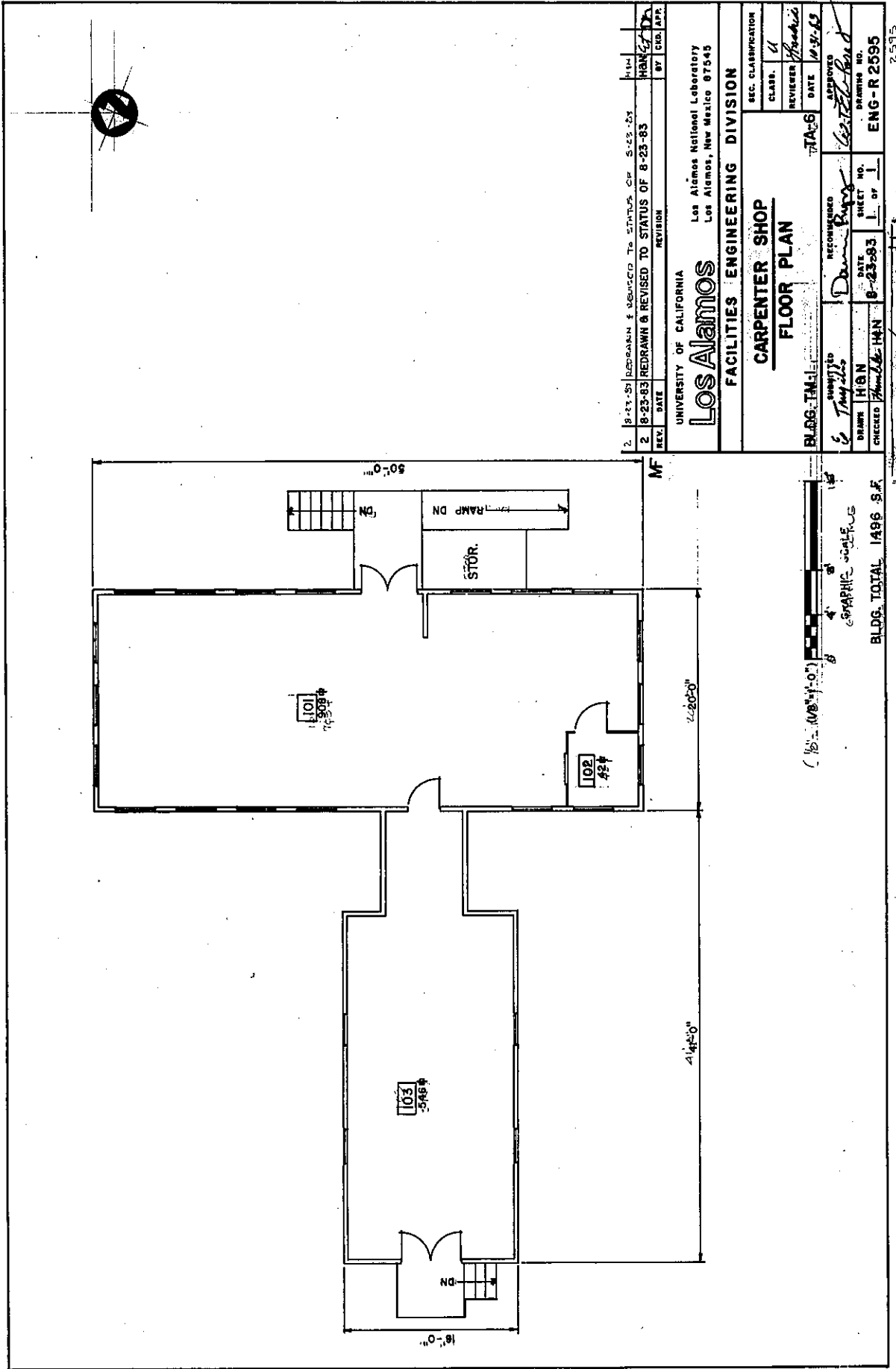

2	8-23-83	REPAIRS & REVISIONS TO STATUS OF 8-23-83	BY	CD. APP.
2	8-23-83	REDRAWN & REVISED TO STATUS OF 8-23-83	BY	CD. APP.

UNIVERSITY OF CALIFORNIA  
**Los Alamos**  
 Los Alamos National Laboratory  
 Los Alamos, New Mexico 97545

**FACILITIES ENGINEERING DIVISION**

**CARPENTER SHOP FLOOR PLAN**

BLDG. T.M.L. TAG-6

SEC. CLASSIFICATION  
 CLASS. U  
 REVIEWER *Frederic*  
 DATE 10-21-83

APPROVED  
*Frederic*  
 DATE 10-21-83

RECOMMENDED  
*Don*  
 DATE 8-23-83

DRAWN *HAN* SHEET NO. 1 OF 1  
 CHECKED *HAN* DATE 8-23-83

DRAWING NO. ENG-R 2595

GRAPHIC SCALE  
 1" = 4'-0"

BLDG. TOTAL 1496 S.F.

REC'D  LOGGED  TO VAULT *HAN*



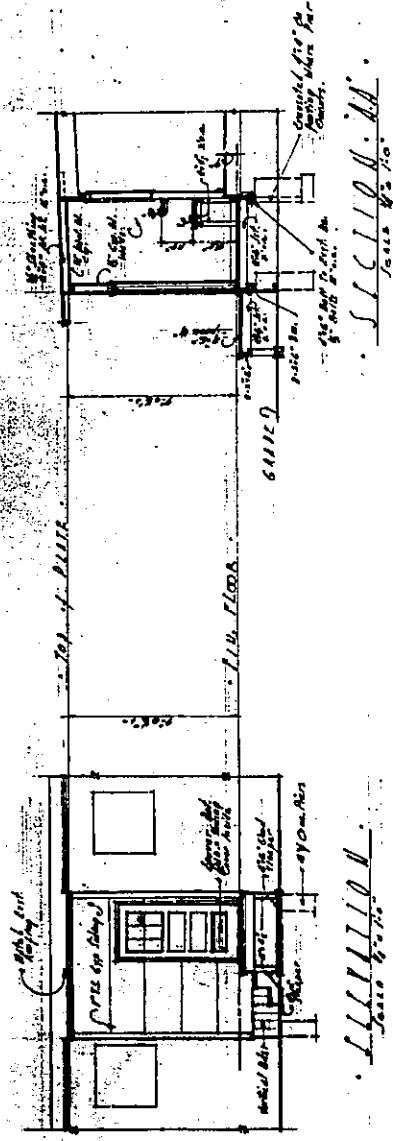

*L. S. LOWMEYER*  
 JAMES W. PE 1900

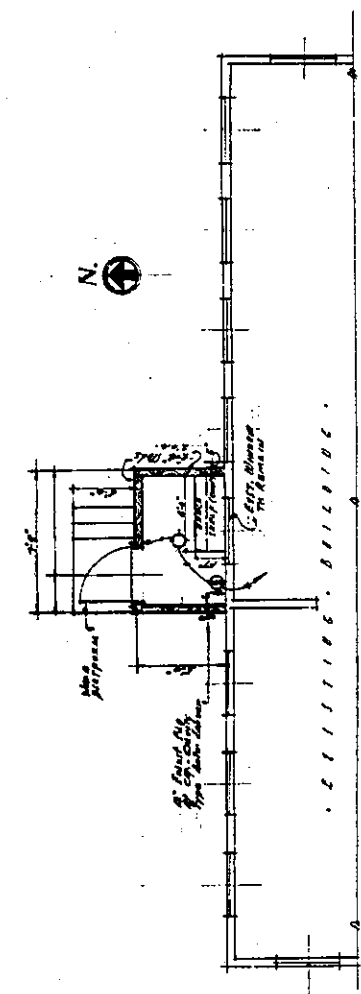

*L. S. LOWMEYER*  
 JAMES W. PE 1900

**GENERAL NOTES:**  
 1. All work to be done in accordance with the specifications and drawings.  
 2. The contractor shall be responsible for obtaining all necessary permits.  
 3. The contractor shall maintain access to all existing utilities.  
 4. The contractor shall be responsible for the safety of all workers.  
 5. The contractor shall be responsible for the disposal of all waste.  
 6. The contractor shall be responsible for the protection of all existing structures.  
 7. The contractor shall be responsible for the completion of all work within the specified time.  
 8. The contractor shall be responsible for the payment of all bills.  
 9. The contractor shall be responsible for the maintenance of all records.  
 10. The contractor shall be responsible for the completion of all work within the specified time.

DATE	NO.	REVISIONS	BY	APPROVED
<b>U. S. ENGINEER OFFICE SANTA FE, NEW MEXICO</b>				
ADDITION TO SPEC. No. 1				
- I. W. WILKINS				
IN	SHEETS	SCALE	SHEET NO.	
			43/100	
OFFICE OF POST ENGINEER		APPROVED RECORD		
SUBMITTED BY		L. S. LOWMEYER		
OK BY	DATE	FILE NO.	PE	1900

L. S. LOWMEYER, ENGR. 1625





### TA-6-2

**Original Function:** Compressor Building

**Current Function:** Vacant

**Historical Significance:** Detonator research and development in support of implosion device.

**Date Constructed:** 1944?

**Associated Theme:** Detonators

**Eligible?:** Yes – “A”

### **Description:**

TA-6-2 is a small mechanical building. The building sits on a concrete slab and foundation. The walls are wood frame with asbestos shingles, and the roof is low slope with composite roof material. The current finishes and exposed materials, such as painted wood and roofing material, have deteriorated. The front elevation has a single door. Several wood louver panels that provide air flow to the original equipment can be seen on the other three walls.



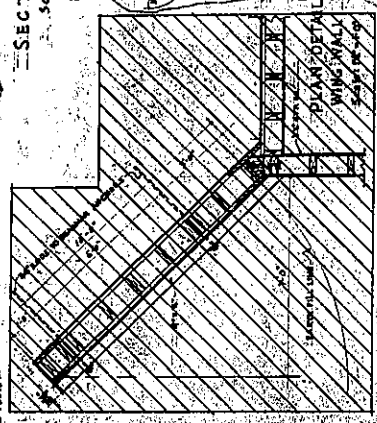
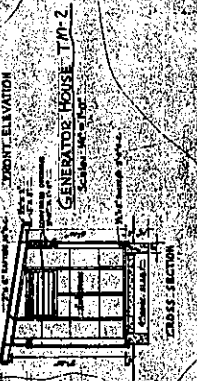
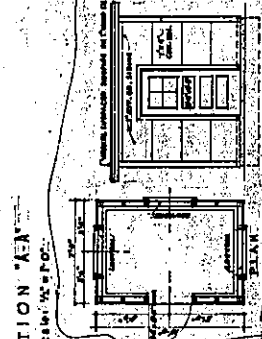
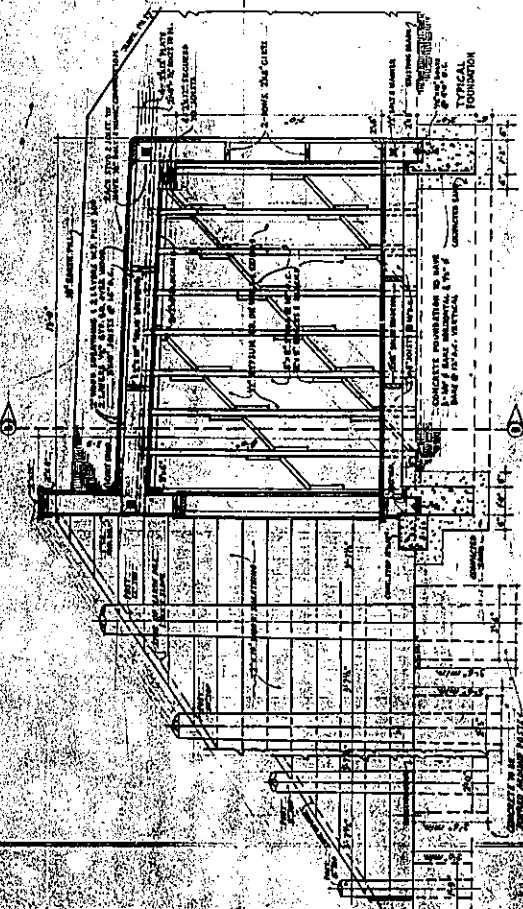
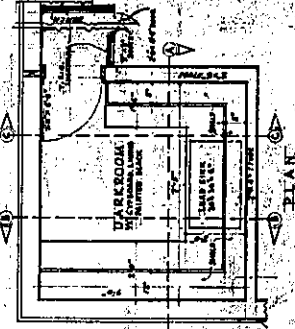
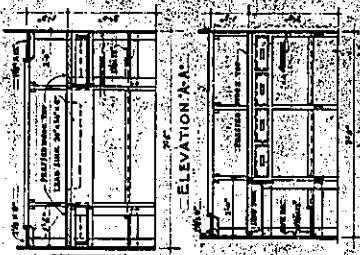
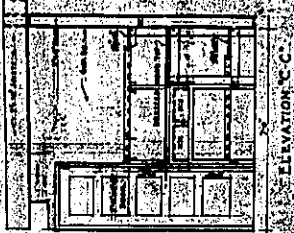
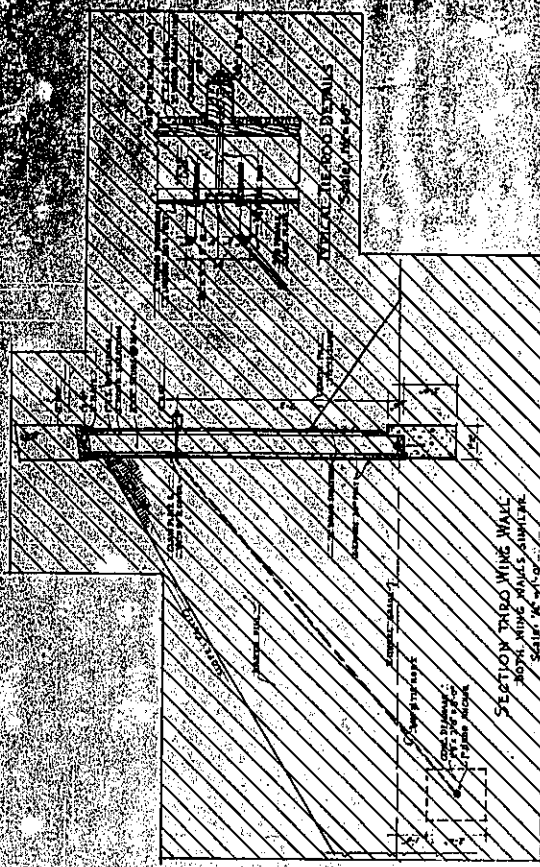

LABORATORY BLDG. TM-1  
 UNIFORMITY OF CONSTRUCTION  
 IN ALL PARTS

LAB BLDG. TM-3

PROJECT NO. 107-2



### TA-6-3

**Original Function:** Fabrication Building

**Current Function:** Vacant

**Historical Significance:** Detonator research and development in support of implosion device.

**Date Constructed:** 1944?

**Associated Theme:** Detonators

**Eligible?:** Yes – “A”

### **Description:**

TA-6-3 is earth bunkered on one elevation. Earth is piled against a timber retaining structure up to the roof level. The other building elevations are typical of the TA-6 buildings. The building is wood frame on a wood foundation and has asbestos shingle siding and a low slope roof with composite sheet roofing material. The windows are wood sash with three-over-three lights. Several wood doors provide access to the interior of the building; the bathroom is one of the areas that can be accessed from the outside. Two lean-to type structures are attached to the side elevation.





**GENERAL NOTES**  
 1. Detail units & sections of door  
 2. Detail units & sections of window  
 3. Detail units & sections of floor  
 4. Detail units & sections of roof  
 5. Detail units & sections of stairs

**PLAN AND ELEVATIONS  
 LABORATORY BUILDING  
 U. C. I. PROJECT AREA**

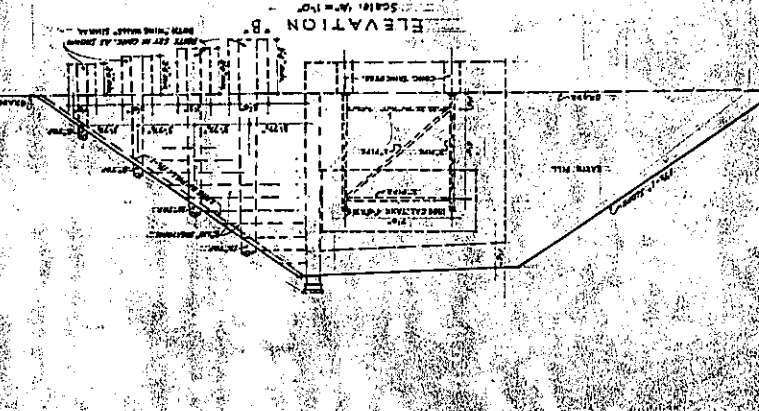
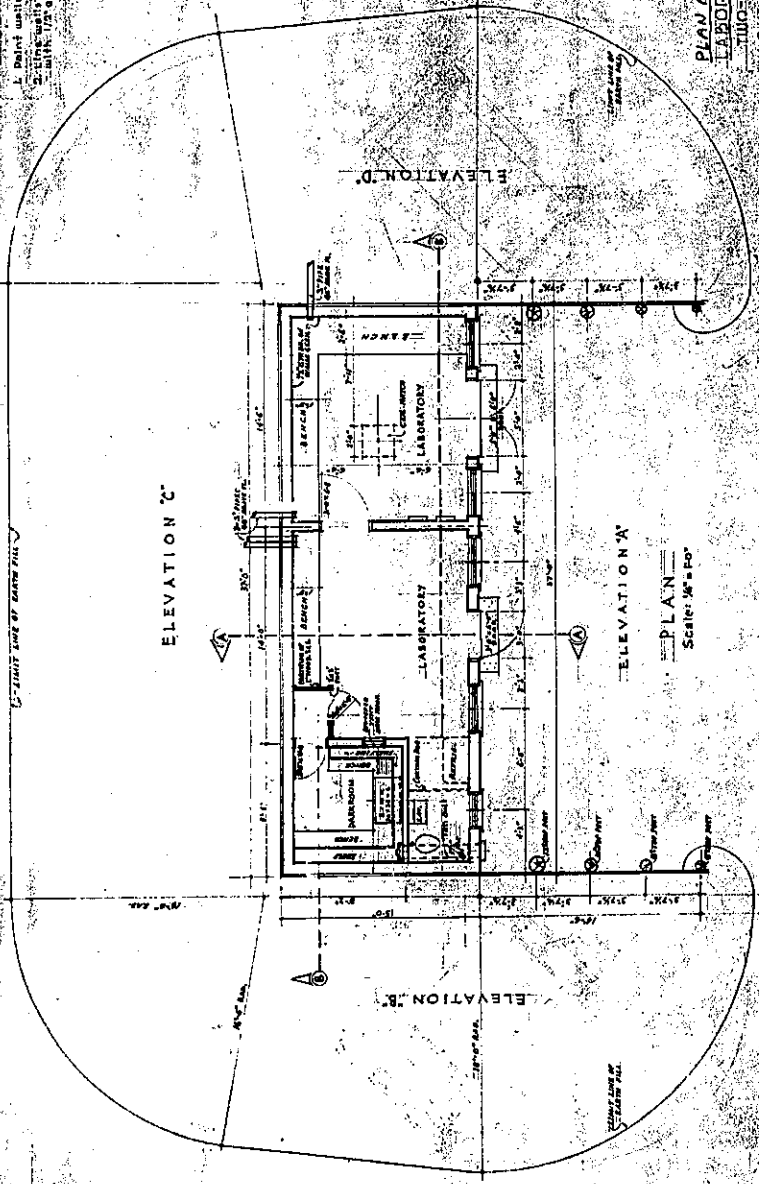
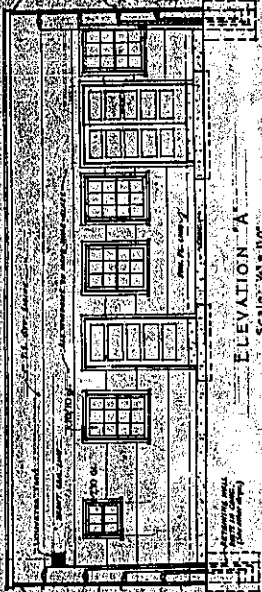

*Approved*  
 [Signature]  
 ARCHITECT



### TA-6-5

**Original Function:** Laboratory Building  
**Current Function:** Vacant  
**Historical Significance:** Detonator research and development in support of implosion device.

**Date Constructed:** 1945?  
**Associated Theme:** Detonators  
**Eligible?:** Yes – “A”

### **Description:**

TA-6-5 is a small windowless structure, typical of the construction at TA-6. The foundation is wood and concrete with a wood-framed floor. The walls and roof structure are also wood framing. The roof is low slope with metal flashing and rolled roofing material, which has been replaced several times over the years. Two window openings on the backside have been covered over. The wood walls are covered with asbestos shingles. Two wood doors on opposite sides of the building provide access; one door is single leaf and the other is double leaf. Raised platforms and ramps lead to the doorways. An exhaust fan and stack is visible on top of the building.



20'-0" 20'-0"

18'-0"

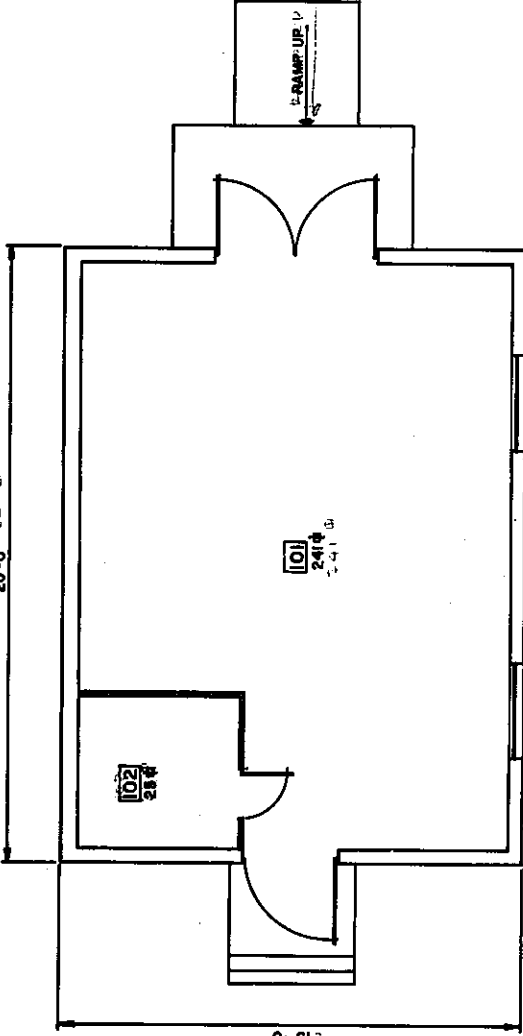

2	12-22-83	REVISION 1 REQUIRED TO STATUS OF 8-23-83	6-23-83	MAN	BY	SR	APR
2	8-23-83	REDRAWN & REVISED TO STATUS OF 8-23-83	8-23-83	MAN	BY	SR	APR
UNIVERSITY OF CALIFORNIA							
<b>Los Alamos</b>							
Los Alamos National Laboratory Los Alamos, New Mexico 87545							
FACILITIES ENGINEERING DIVISION							
LABORATORY BUILDING							
FLOOR PLAN							
BLDG. TM: 6							
DATE: 10-21-78							
CLASS: 4							
REVISION: 1							
RECOMMENDED BY: <i>W. T. Kelly</i>							
DATE: 6-22-94							
DRAWN: <i>H. B. N.</i>							
CHECKED: <i>W. H. HAN</i>							
SHEET NO. 1 of 1							
DRAWING NO. ENG-R2599							

MF

(1/4"=1'-0")  
GRAPHIC SCALE  
GRAPHIC SCALE

BLDG. TOTAL 296 S.F.



TA-6-6

**Original Function:** Laboratory and Office

**Current Function:** Vacant

**Historical Significance:** Detonator research and development in support of implosion device.

**Date Constructed:** 1945?

**Associated Theme:** Detonators

**Eligible?:** Yes – “A”

**Description:**

TA-6-6 is representative of the standard vernacular military type barrack building. It is long and narrow and has a medium slope hip roof with roll type roofing material. The building is wood frame with a wood post and beam foundation on concrete bases or piers. The walls are sheathed with asbestos wall shingles. A corrugated steel skirt has been added to the base at the elevated floor level. Numerous windows penetrate the walls. The wood sash windows are three-over-three panes with bug screens added. A wood door and porch located at the side center of the building serves as the front door. One end of the building has a covered dock type entry and the opposite end of the building joins a lean-to structure that contains the boiler with the expansion tank on a steel stand outside the building.

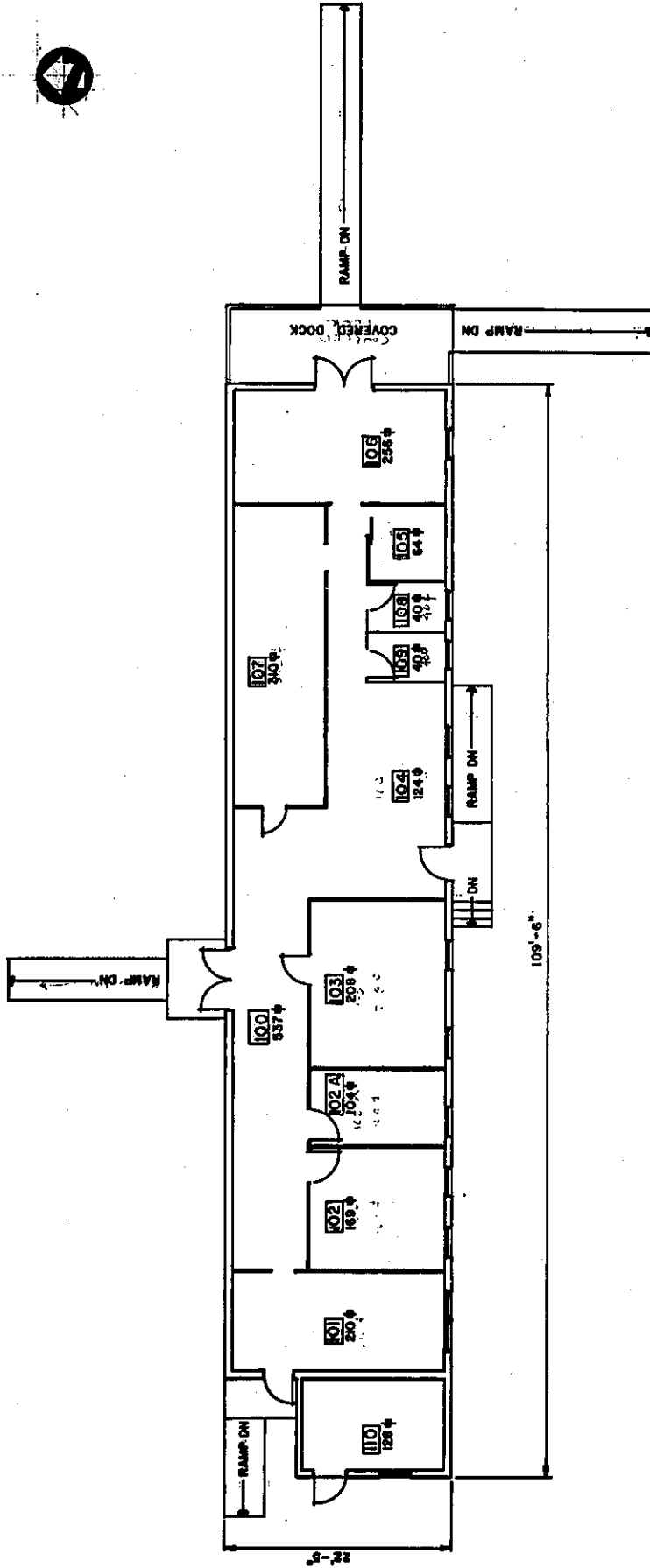

2	8-22-83	REVISIONS	REVISED TO STATUS OF 8-22-83	DATE	8-22-83	BY	MM
3	8-22-83	REVISIONS	REVISED TO STATUS OF 8-22-83	DATE	8-22-83	BY	MM
UNIVERSITY OF CALIFORNIA				Lee Alamos National Laboratory Lee Alamos, New Mexico 87545			
Los Alamos				FACILITIES ENGINEERING DIVISION			
LABORATORY OFFICE				SHOP BUILDING			
FLOOR PLAN				TA-6			
BLDG. TM-6				REVISIONS			
M. J. H. H.				DATE			
8-22-83				DRAWN BY			
M. J. H. H.				CHECKED BY			
M. J. H. H.				DATE			
8-22-83				PROJECT NO.			
M. J. H. H.				SHEET NO.			
M. J. H. H.				1 of 1			
M. J. H. H.				ENG-R2600			

MF

1/32" = 1'-0" GRAPHIC SCALE

BLDG. TOTAL - 2184 S. F. F.

RCD LOGGED TO VAULT







### TA-6-7

**Original Function:** Laboratory

**Current Function:** Vacant

**Historical Significance:** Detonator research and development in support of implosion device.

**Date Constructed:** 1945?

**Associated Theme:** Detonators

**Eligible?:** Yes – “A” and “C”

### **Description:**

TA-6-7 is a small hardened laboratory building. It is a cast-in-place, board form, concrete structure. The flat roof is cast-in-place concrete, and the foundation and floor are also concrete. The ends of the building express the openings, and small concrete porches are visible at the door openings. A steel vault type door and frame are located on one end of the building. The opposite end of the building contains a blast or over-pressure panel constructed of wood frame and corrugated metal. The building contains two rooms. The back room is reinforced with multiple anchor bolts protruding from the sides of the building. The bolts support interior steel panels, which provide explosive protection for the interior of the structure. One exhaust fan is evident on the end of the structure.

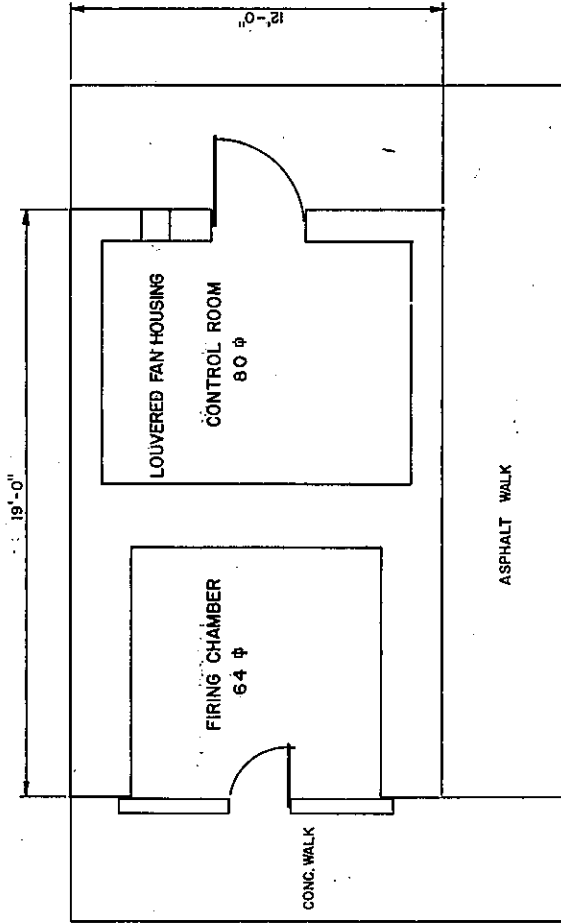

REV.	DATE	REVISION	BY	CHKD.
1	8-23-83	REDRAWN & REVISED TO STATUS OF 8-23-83	HBN	ADA
UNIVERSITY OF CALIFORNIA <b>Los Alamos</b> Los Alamos National Laboratory Los Alamos, New Mexico 87545				
FACILITIES ENGINEERING DIVISION				
SEC. CLASSIFICATION				
CLASS. <i>U</i>				
REVIEWER <i>[Signature]</i>				
DATE 8-23-83				
APPROVED <i>[Signature]</i>				
DATE 3-6-84				
BLDG. TM-7				
RECOMMENDED <i>[Signature]</i>				
DATE 8-23-83				
DRAWN HBN				
SHEET NO. 1 OF 1				
CHECKED <i>[Signature]</i>				
DRAWING NO. ENG-R 2601				

MF

(1/4"=1'-0")

GRAPHIC SCALE

BLDG. TOTAL 144 S.F.

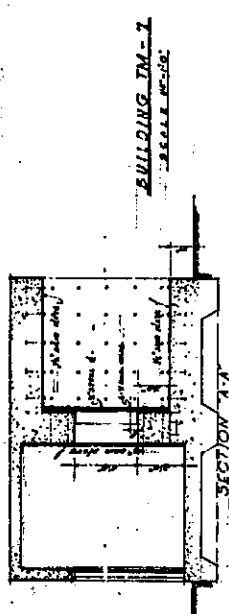
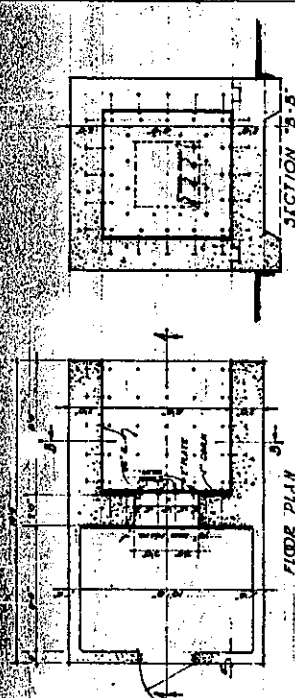

BUILDING TM-7  
SCALE: 1/8"=1'-0"

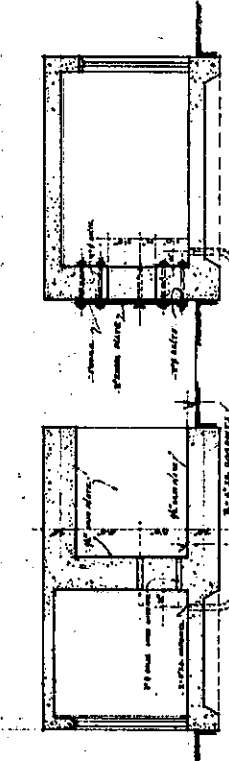
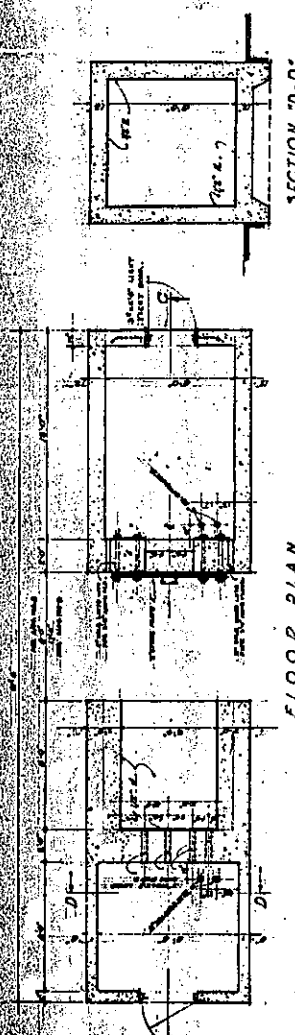

BUILDINGS TM-8 & TM-9  
SCALE: 1/8"=1'-0"

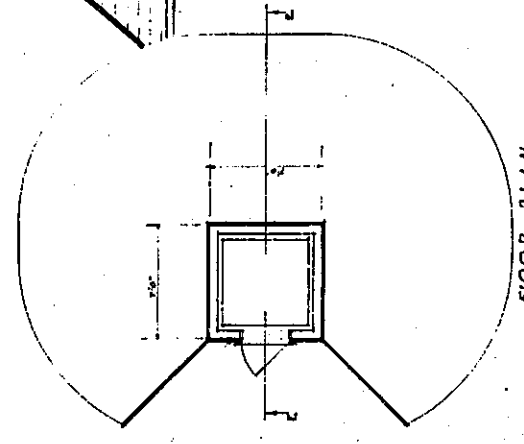

BUILDING TM-4  
SCALE: 1/8"=1'-0"

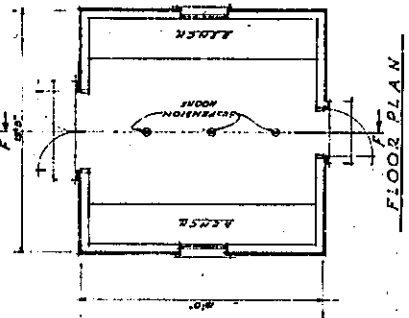
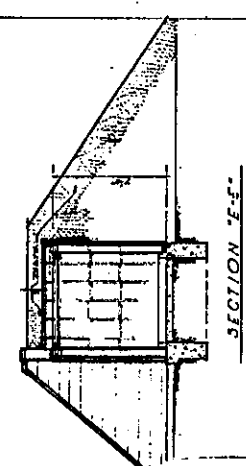

BUILDING TM-5  
SCALE: 1/8"=1'-0"

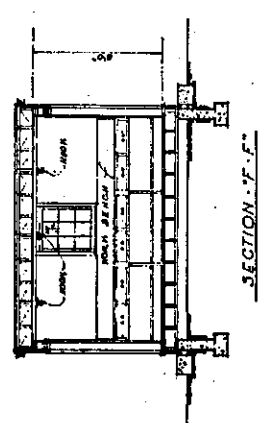

PROPOSED BUILDINGS  
2 MILE MESA  
BUILDINGS TM-1-8-9-4-5  
W.C. BRUGER-ARCHT.  
1-1-45 (REVISED 7/1947)  
REVISED TITLE 8-19-48 JTW



### TA-6-8

**Original Function:** Laboratory

**Current Function:** Vacant

**Historical Significance:** Detonator research and development in support of implosion device.

**Date Constructed:** 1945?

**Associated Theme:** Detonators

**Eligible?:** Yes – “A” and “C”

### **Description:**

TA-6-8 consists of three separate building forms; two concrete structures and a wood-frame two-story connector element. The concrete sections are similar in materials to each other and to the other concrete buildings at TA-6. They have concrete cast-in-place foundations, floors, walls, and roofs. Each concrete building has a steel plate and frame door and a concrete porch at the outside end. One of the concrete structures shows exposed anchor bolts, which attach the interior metal plate to the wall. There are no other windows or openings visible on the exterior walls. The two-story wood-frame connector structure is sheathed with standard asphalt, wood sleepers, and asbestos shingles attached to the sleepers. The roof is flat with a slight overhang and wood fascia boards. Steel structural elements stand off from the two-story structure, supporting equipment inside the building. Wood doors on each side of the wood structure provide access to the laboratory space within. Steam and electric utility connections are visible entering the structure.

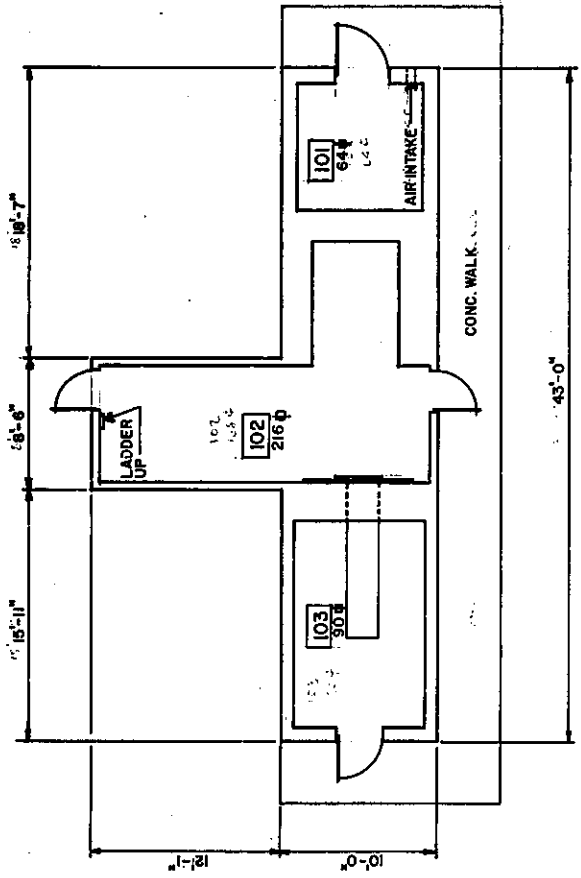

REV.	DATE	REVISION	BY	CHKD.
3	2-3-84	REVISED TO STATUS OF 2-3-84		DC
2	8-23-83	REDRAWN & REVISED TO STATUS OF 8-23-83		DC
1				

UNIVERSITY OF CALIFORNIA		Los Alamos National Laboratory Los Alamos, New Mexico 87548	
<b>Los Alamos</b>			
FACILITIES ENGINEERING DIVISION			
LABORATORY BUILDING FIRST FLOOR PLAN			
BLDG. TM-8	TA-8	REC. CLASSIFICATION	CLASS. <i>U</i>
DESIGNED BY <i>Le. Traylor</i>	DATE 8-23-83	REVISED BY <i>Richard</i>	DATE 9-22-84
CHECKED BY <i>Le. Traylor</i>	APPROVED BY <i>Richard</i>	REVISIONS	
DRAWN BY <i>H. B. N.</i>	SHEET NO. 1 of 2	DATE 8-23-83	ENGINEER NO. ENG-R 2602

MF



FIRST FLOOR. 370 S.F.



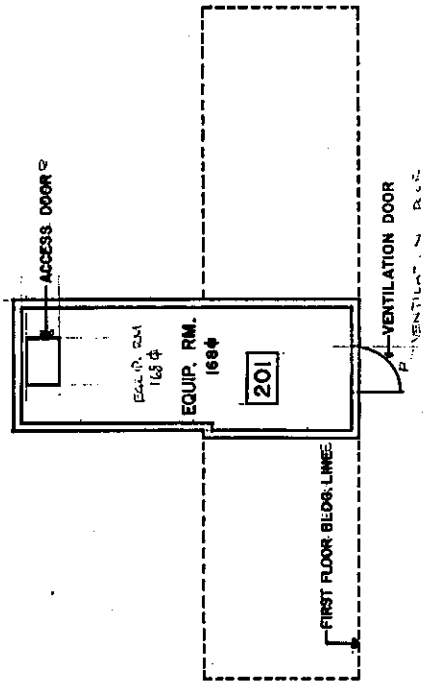

2	8-23-83	UNDRAWN	REVISED TO STATUS OF 8-23-83	REV	
2	8-23-83	REDRAWN	REVISED TO STATUS OF 8-23-83	REV	10-23-83
REV. DATE		REVISION		BY	DATE
UNIVERSITY OF CALIFORNIA <b>Los Alamos</b> Los Alamos National Laboratory Los Alamos, New Mexico 87545					
FACILITIES ENGINEERING DIVISION					
LABORATORY BUILDING			SEC. CLASSIFICATION		
SECOND FLOOR PLAN			CLASS. 4		
BLDG. T.M. 58			REVISION 10-23-83		
DRAWN BY <i>L. Traylor</i>		RECORDED BY <i>D. R. Ryan</i>		APPROVED BY <i>L. T. Traylor</i>	
CHECKED BY <i>M. H. N.</i>		DATE 8-23-83		SHEET NO. 2 OF 2	
BLDG. TOTAL 538 S.F.			DRAWING NO. ENG-R 2603		

GRAPHIC SCALE:  
1" = 10'-0"

FIRST FL. 370 S.F.  
SECOND FL. 168 S.F.  
BLDG. TOTAL 538 S.F.



### TA-6-9

**Original Function:** Firing Chamber

**Current Function:** Vacant

**Historical Significance:** Detonator research and development in support of implosion device.

**Date Constructed:** 1945?

**Associated Theme:** Detonators

**Eligible?:** Yes – “A” and “C”

### **Description:**

TA-6-9 is a unique two-structure layout characterized by two similar cast-in-place concrete buildings. The west building is similar to building TA-6-7. It has cast-in-place concrete walls, floor, and roof. A wood vault door is located on one end and a framed opening is visible on the other. One interior room is paneled with steel plate and the anchor bolts are visible on the outside. The east building is also a cast-in-place concrete structure. A large expansion tank is mounted on a steel frame adjacent to the structure. The east end contains a steel door; the west end has a lift-away steel plate serving as a door and blast protection. The two buildings face each other end to end and are connected by a steel plate floor and an exposed wood fence structure.

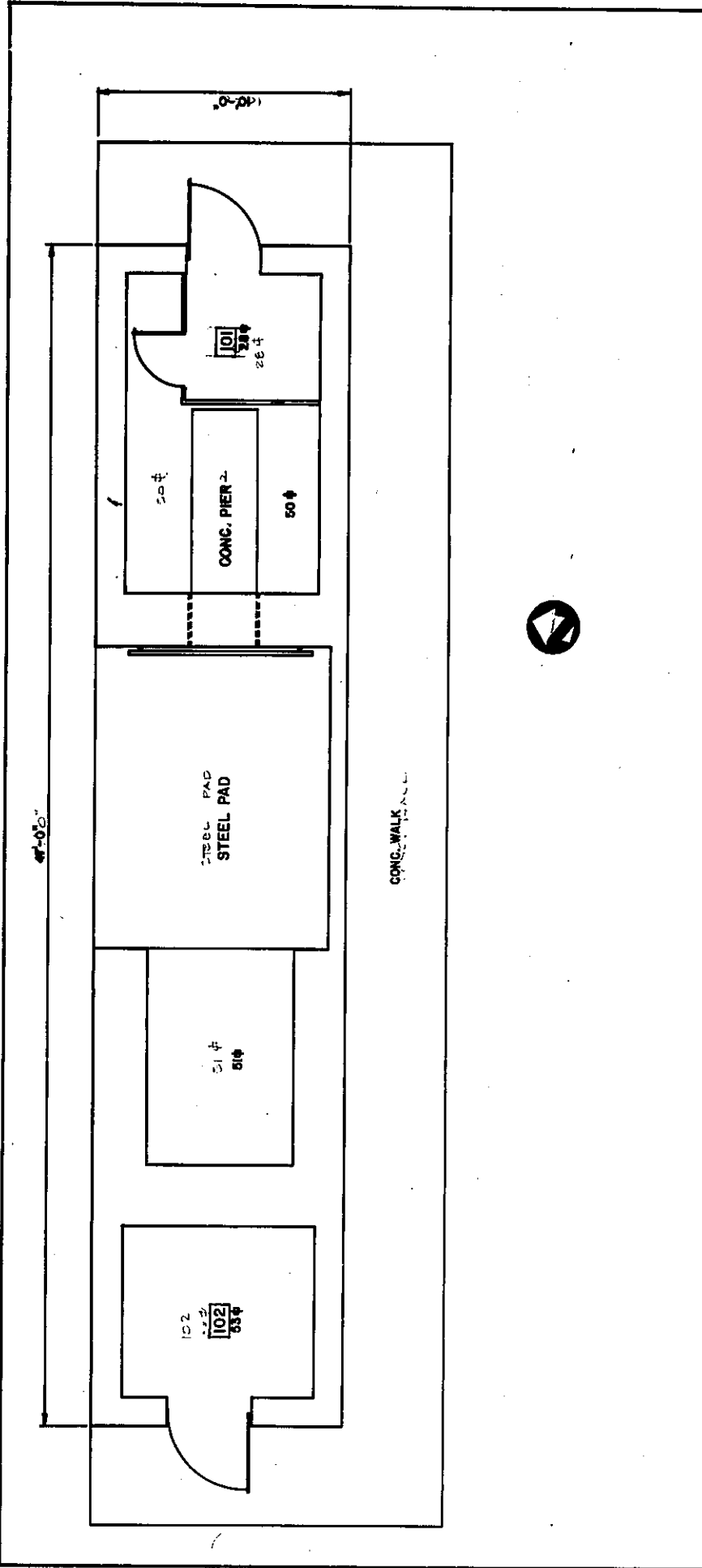

1	5-23-83	NOTED & RECORDED TO STATUS OF 3-23-83	MEM
1	8-23-83	REDRAWN & REVISED TO STATUS OF 8-23-83	MEM
REV.	DATE	REVISION	BY
			DATE

UNIVERSITY OF CALIFORNIA  
**Los Alamos** Los Alamos National Laboratory  
 Los Alamos, New Mexico 97845

**FACILITIES ENGINEERING DIVISION**  
**FIRING CHAMBER**  
**FLOOR PLAN**

BLDG. TM-9

DESIGNED BY: *[Signature]*  
 CHECKED BY: *[Signature]*  
 DATE: 8-23-83  
 SHEET NO. 1 of 1

REV. CLASSIFICATION  
 CLASS. 4  
 REVIEWED *[Signature]*  
 DATE 8-23-83

DRAWING NO. ENG-R 2604

MF

1/4" = 1'-0" (1/8" = 1'-0")

GRAPHIC SCALE  
 GRAPHIC SCALE

TOTAL BLDG. TOTAL 102 S.F.



TA-6-37 (LA 25284)

**Original Function:** Concrete Bowl/  
Experimental Area  
**Current Function:** Not in Use  
**Historical Significance:** Plutonium  
recovery experiment in support of first  
implosion device.

**Date Constructed:** 1944  
**Associated Theme:** Implosion (Atomic Bomb)  
**Eligible?:** Yes – “A” and “C”

**Description:**

TA-6-37 is a large concrete bowl constructed during the Manhattan Project for use as a scaled-down experimentation platform. The bowl consists of a sloping, ground level concrete pad with a drain in the center of the structure. The concrete bowl is 200 ft in diameter; it was poured in 16 pie-shaped wedges. The center of the bowl has a raised dome with a metal cover on top. Near the north side of the bowl is a wood-framed and gravel-filled ramp.

The Manhattan Project scientists toyed with the idea of using a water recovery method in which the bomb, surrounded by air space, would be suspended in a tank of water and fragments would be stopped by a 50 to 1 ratio of water to high explosive mass. The feature was constructed for water recovery tests in late 1944. The water recovery shots used depleted uranium and testing continued until the spring of 1945. Shake tests, probably of explosive assemblies, were also conducted in this structure in 1945. This included the “jumbinos” or smaller versions of Jumbo (a huge steel containment vessel) within which the bomb would be exploded.







TA-6 Bomb Cover (LA 131234 C)

<b>Original Function:</b>	Bomb Cover	<b>Date Constructed:</b>	Circa 1943-1946?
<b>Current Function:</b>	Not in Use	<b>Associated Theme:</b>	Stockpile
<b>Historical Significance:</b>	Early weapons storage.	<b>Eligible?:</b>	Yes – “A”

**Description:**

This is the remains of a wooden storage shed associated with storage of atomic bomb components during the Manhattan Project. The overall configuration of the original shed is similar in size and appearance to a dog house, thus providing the basis to references to this structure as a “dog hut.”

LA 131234 C is the only part of four remaining sheds not burned during the Cerro Grande Fire of May 2000. This structure is the top portion of a shed. The cover (top) is ~3.1 m long by ~2.4 m wide. The structure has a pitched roof although some slumping has occurred. A straight galvanized metal pipe and a rusted coiled pipe were noted in the cover debris. The northeast side of the cover is in good shape and shows how the “top” sides were constructed. The “roof” had an overhang and some sort of black roofing paper was nailed to the outer edge.



Profile: West End View

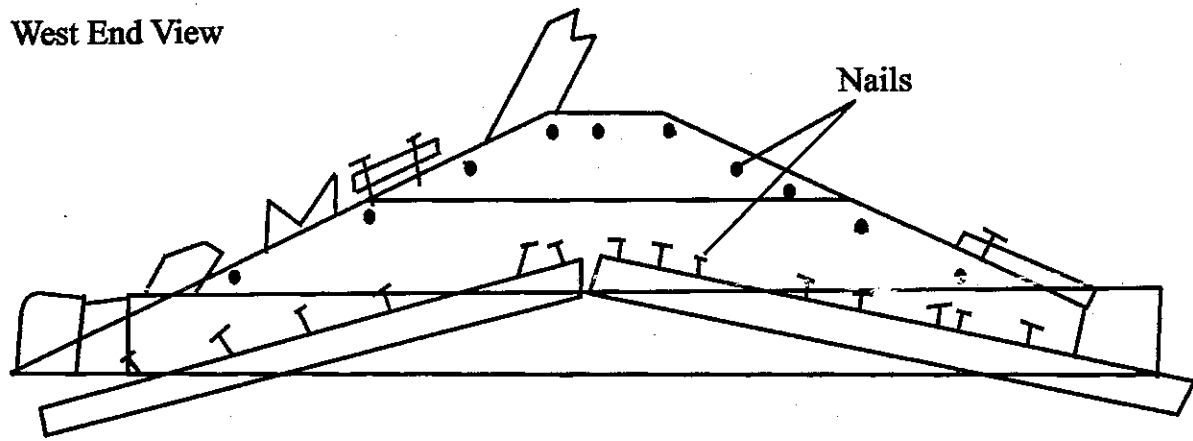

Plan View

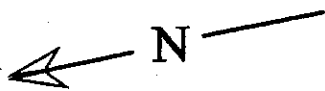
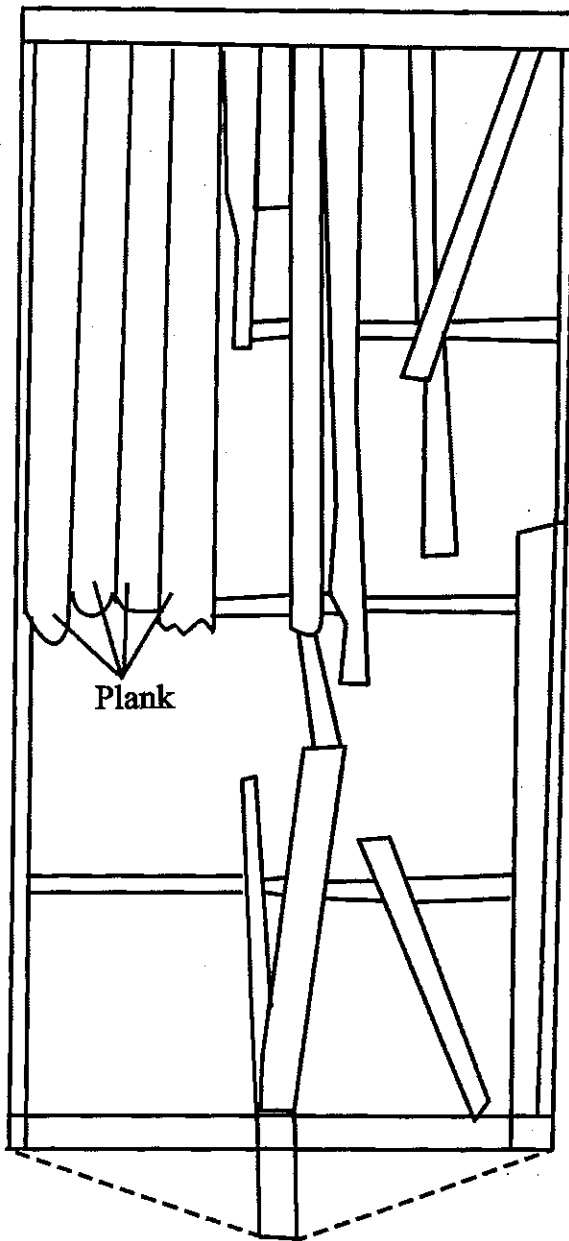

**LA 131234**

**Structure B**

**Wooden Storage Structure**

**8/14/00 B.V., A.M.**

**Not to Scale**

LA 131234 C is similar in construction to LA 131234 B (depicted on this drawing but destroyed by the Cerro Grande Fire).



LA 131235 A



LA 131235 A

TA-7 Firing Sites (LA 131235 A, B, and C)

<b>Original Function:</b>	Firing Sites	<b>Date Constructed:</b>	Circa 1943-1946?
<b>Current Function:</b>	Not in Use	<b>Associated Theme:</b>	High Explosives and Detonators
<b>Historical Significance:</b>	High explosives and detonator field testing in support of implosion device.	<b>Eligible?:</b>	Yes – “A”

**Description:**

There are three firing site areas located at TA-7. Most of the wooden components associated with these firing areas burned during the Cerro Grande Fire of May 2000.

The first firing area, LA 131235 A (7-001a), is located on the mesa top at old TA-7, northwest of LA 131235 B (7-001b). The firing site is a circular earthen mound with an opening to the east and measures 22 m by 22 m. Historic experimental debris associated with the firing activities is present. Prior to the fire, a long wooden “chute” was located within the eastern opening of the mound. The chute was constructed out of wooden planks, wire, and nails. An electrical outlet and associated electrical pipe-housing for the wiring extended from the northwest end of the chute to the southeast end, along the southern side of the structure. The May 2000 fire destroyed the wooden chute feature.

The second firing area, LA 131235 B (7-001b), is located on top of Two-Mile Mesa southeast of 7-001a and northwest of area LA 131235 C. The firing site consists of a circular earthen mound with associated cast metal debris. This firing area measures 22 m by 28 m and the mound height is 1.82 to 2.43 m. There is an opening to the mound on the western end. The “ring” (mounded area around the depression) is approximately 3.5 m thick with the mound being approximately 6 to 10 ft high. The southern half of the mound is lower than the rest. Several metal artifacts were found including a cast pipe and gas can. Other items have unknown functions and include

square metal box-like frames with circular holes in the sides. A very large cast iron or metal cover (likely a hood or cover for detonations) was found immediately southwest of the mound. This cover contains cut holes on the end and a small rectangular opening on the side.

The third experimental area, LA 131235 C, consists of five metal pipes sticking out of a human-made mound of tuff rocks and dirt. The experimental area is located on a sloping bank near the edge of a mesa. The area measures 15 m by 11 m. Artifacts in the area include eight pieces of glass (including the base of a large lab bottle), one black slag piece, and one shrapnel fragment. Prior to May 2000, a wooden frame housing the pipes was located on the northern side of the mound, which is built on an embankment. A downed wood and barbed wire fence line was also located in the area. More downed fence line and several long wooden planks with nails were located to the south of the mound. Much of the wooden planking probably served as a form of cover or “roofing” for the southern end of the pipes (one of the pipes had a cover on the northern end). The Cerro Grande Fire destroyed the majority of the wooden planking and fencing materials.

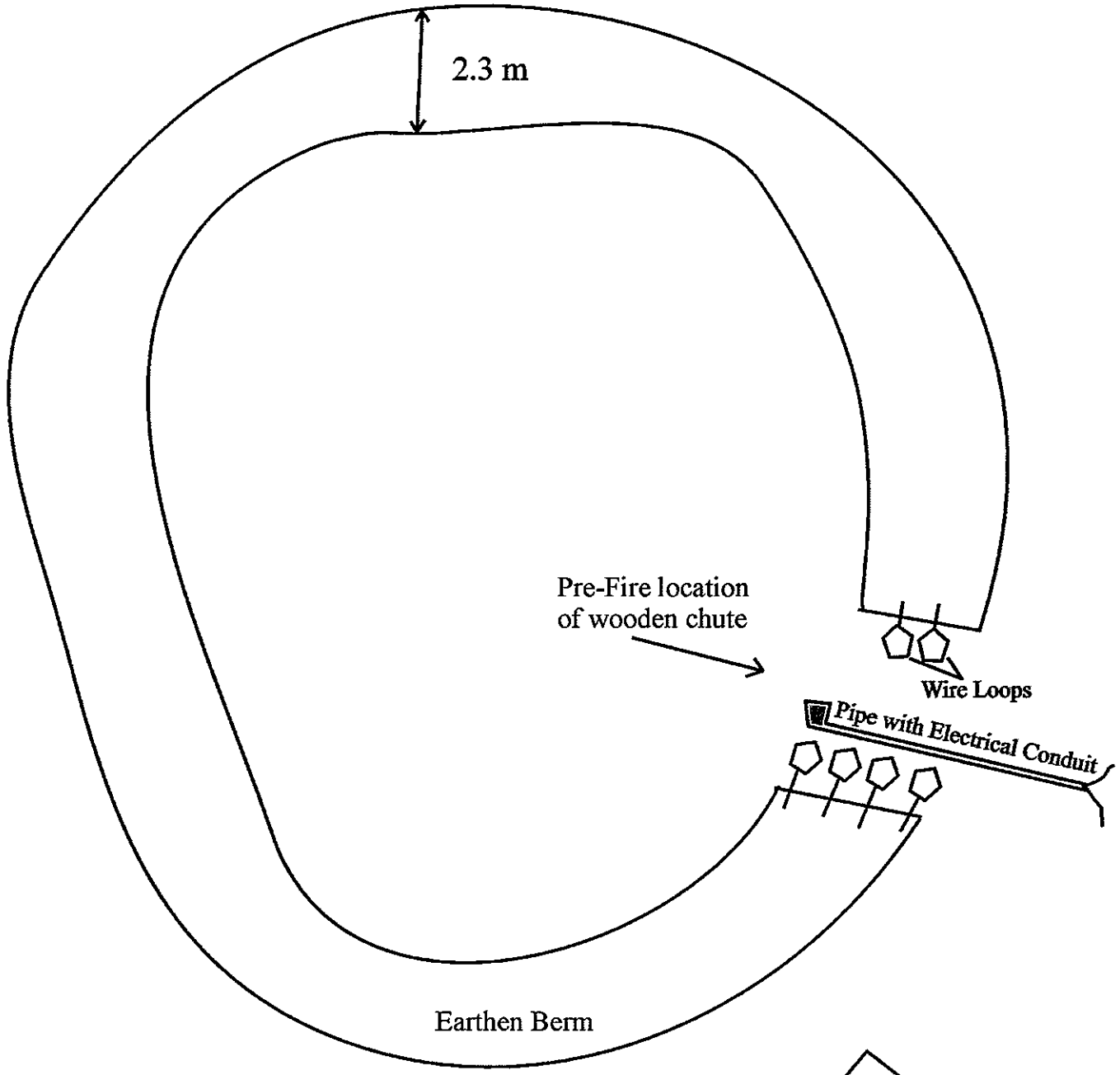

Pre-Fire location  
of wooden chute

Wire Loops

Pipe with Electrical Conduit

Earthen Berm

Metal Debris

LA 131235-A

Firing Pit

Approximate Scale

0 5m

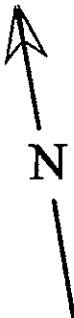

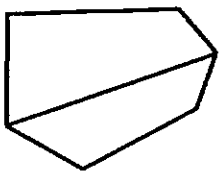
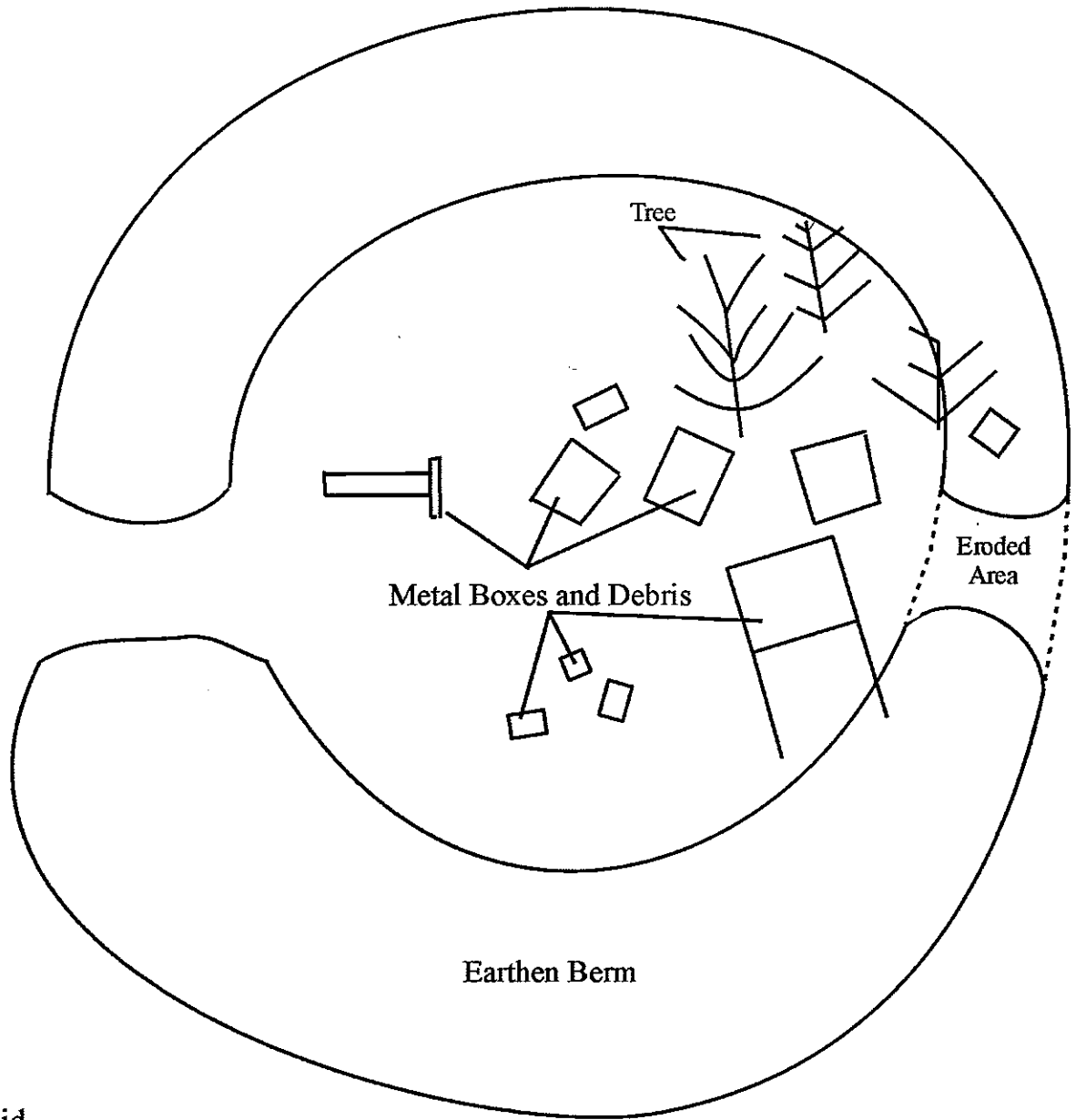

Steel Detonation Lid

**LA 131235-B**

**Firing Pit**

**Approximate Scale**

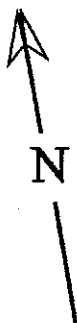
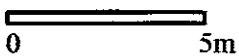

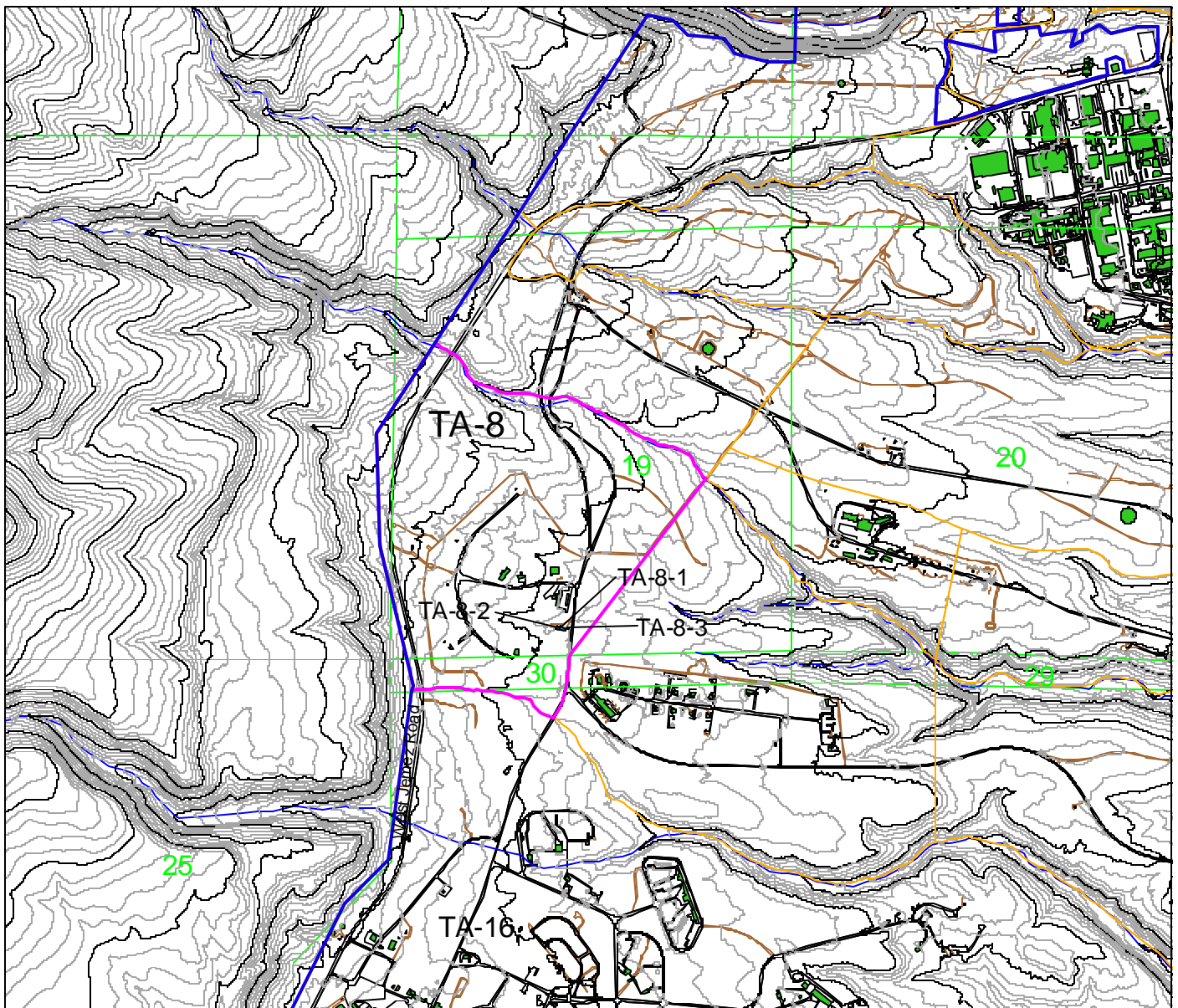

Frijoles Quad

# Los Alamos National Laboratory

Cultural Resources Management Team  
RRES-ECO Ecology Group

1:24000

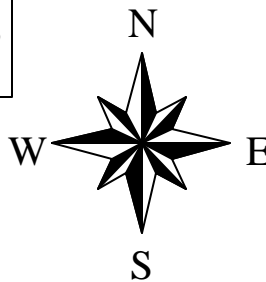

## Manhattan Project Buildings

### TA-8

- Manhattan Project Buildings
- Los Alamos National Laboratory
- Tech Area 8
- Tech Areas
- 20 Foot Contours
- 100 Foot Contours
- Drainage
- Township, Section, Range
- USGS 7.5 Minute Quad
- Roads
- Roaddirt
- Parkpave
- Parkdirt
- Buildings/Structures

Map 7



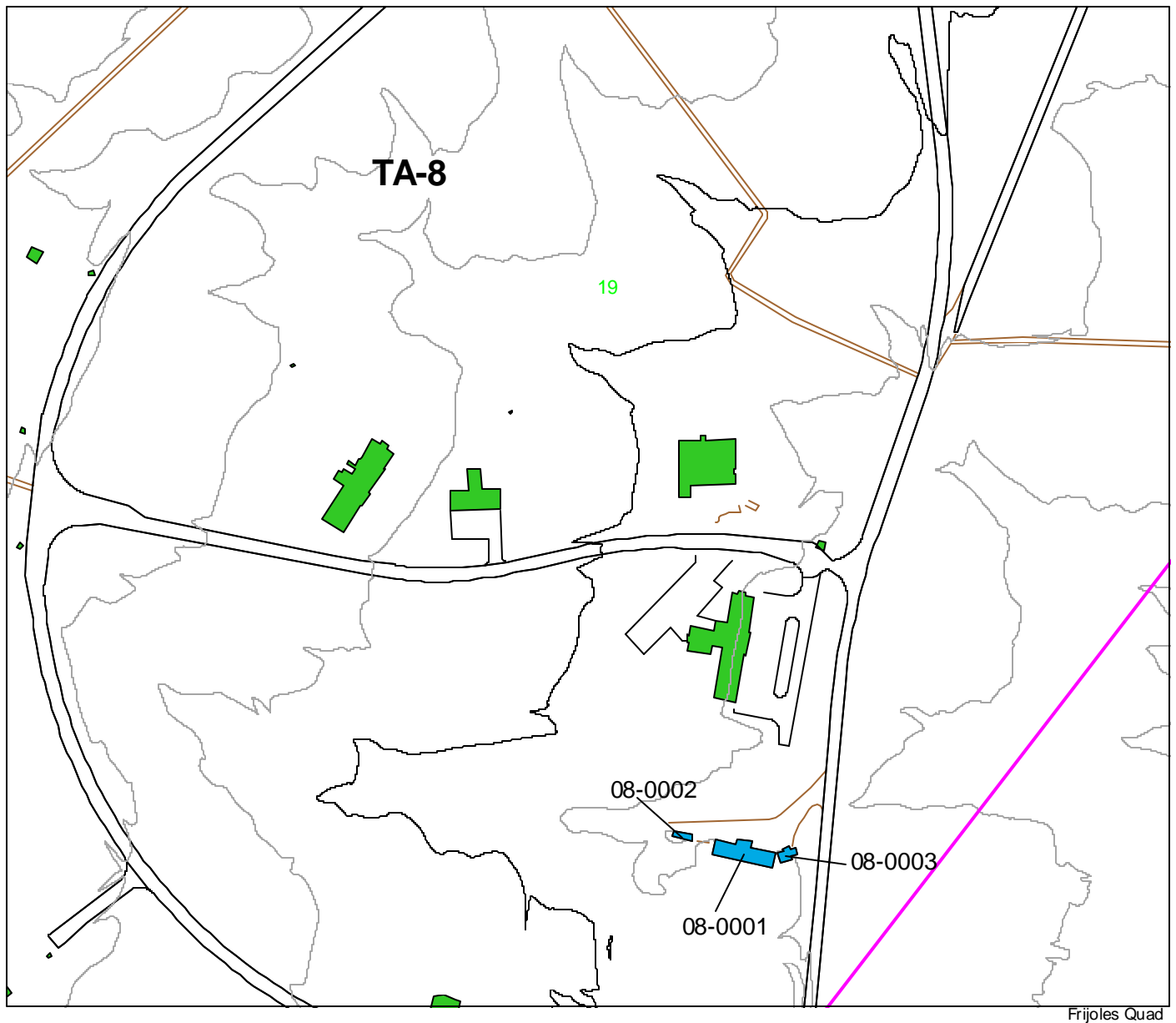

Frijoles Quad

# Los Alamos National Laboratory

Cultural Resources Management Team  
RRES-ECO Ecology Group

1:3500

200 0 200 400 Feet

70 0 70 140 Meters

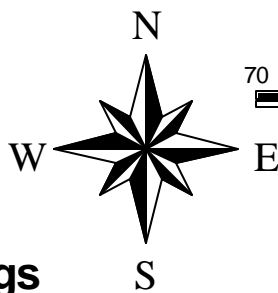

- Manhattan Project Buildings
- Los Alamos National Laboratory
- Tech Area 8
- Tech Areas
- 20 Foot Contours
- 100 Foot Contours
- Drainage
- Township, Section, Range
- USGS 7.5 Minute Quad
- Roads
- Road/dirt
- Park/pave
- Park/dirt
- Buildings/Structures

## Manhattan Project Buildings

## TA-8 Closeup

Map 8



### TA-8-1

**Original Function:** Laboratory and Shop    **Date Constructed:** 1943  
**Current Function:** Vacant    **Associated Theme:** Gun Device (Atomic Bomb)  
**Historical Significance:** Gun Device development and testing in support of “Little Boy” bomb.    **Eligible?:** Yes – “A” and “C”

### **Description:**

TA-8-1 is the central structure of a group of three buildings located in the historic Anchor West or “Gun Site” area of TA-8. It is a cast-in-place, board form, concrete building with the south elevation earth-sheltered into a modest hillside and berm. The roof structure is earth-covered concrete. The building is long and narrow with a covered dock and an enclosed dock area on the exposed north side. The finished floor level is elevated three ft above the driveway area. The enclosed dock area is wood frame with asbestos shingles and a sloped roof coincidental with the dock roof. The exterior doors are raised wood panel with two-over-two window lights. The only windows to the outside are the glass panes in the doors.

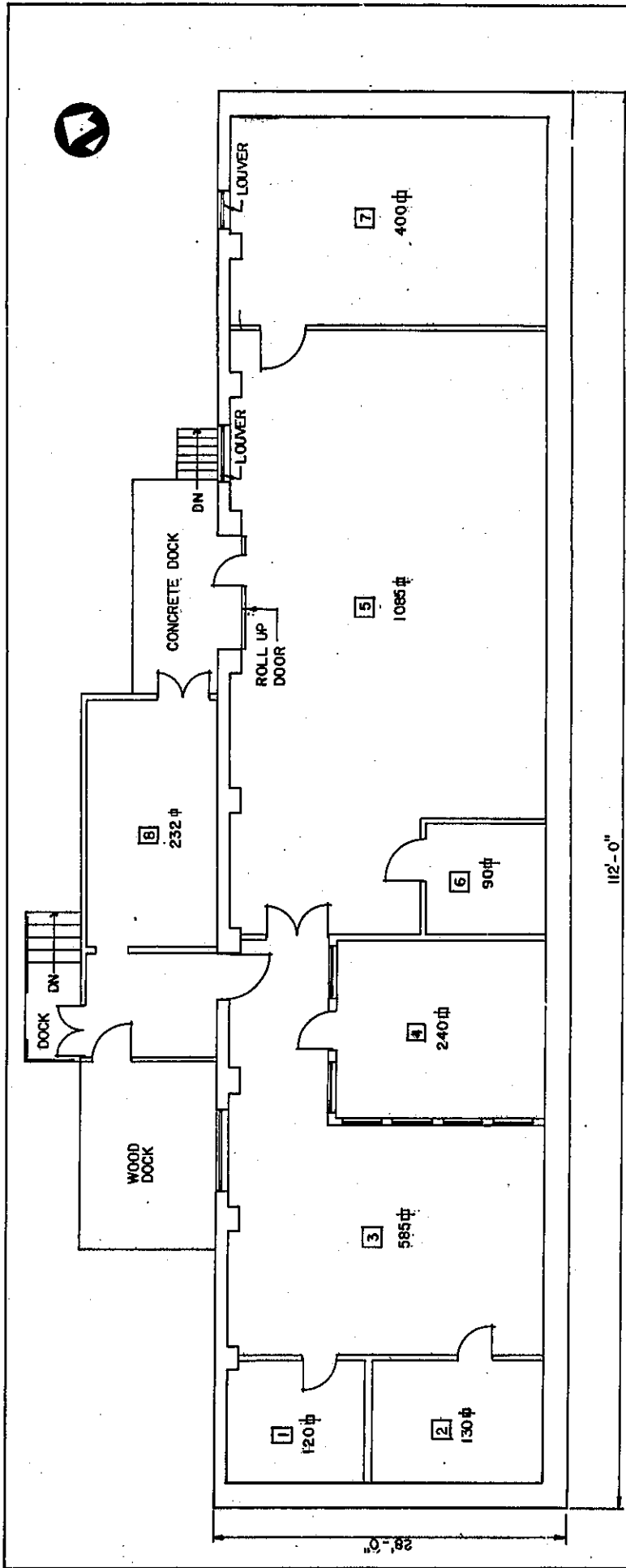

MF

REV.	DATE	REVISION	BY	APP.
1	8-25-83	REDRAWN & REVISED TO STATUS OF AUGUST 25, 1983	HAN	HT
UNIVERSITY OF CALIFORNIA <b>Los Alamos</b> Los Alamos National Laboratory Los Alamos, New Mexico 97545				
FACILITIES ENGINEERING DIVISION				
LAB & SHOP BLDG. FLOOR PLAN				
BLDG. AW-1		TASK 8	SEC. CLASSIFICATION	
SUBMITTED BY <i>to M... ..</i>		RECOMMENDED BY <i>D... ..</i>	CLASS.	4
DRAWN BY <i>HAN</i>		DATE 8-25-83	REVIEWER <i>HAN</i>	DATE 8-6-88
CHECKED BY <i>HAN</i>		SHEET NO. 1 OF 1	APPROVED BY <i>HAN</i>	
		DRAWING NO. ENG-R2610		



BLDG. TOTAL 2882 S.F.

2610





## TA-8-2

**Original Function:** Shop and Storage

**Date Constructed:** 1943

**Current Function:** Vacant

**Associated Theme:** Gun Device (Atomic Bomb)

**Historical Significance:** Gun Device development and testing in support of “Little Boy” bomb.

**Eligible?:** Yes – “A” and “C”

### **Description:**

TA-8-2 is at the west end of the “Gun Site” complex. It is a cast-in-place, board form, concrete building. It is earth bermed on the southwest elevation and the roof structure is earth covered with vegetation covering the area. A concrete retaining wall to the west connects to the building and creates the end of the drive pad in front of the group of buildings. Two double metal doors enter the building at ground level. The building is windowless. An exhaust ventilation duct is attached to the outside of the building. A unique feature of this building is the boat-tail (rounded) east elevation wall creating a robust appearance to the facility.

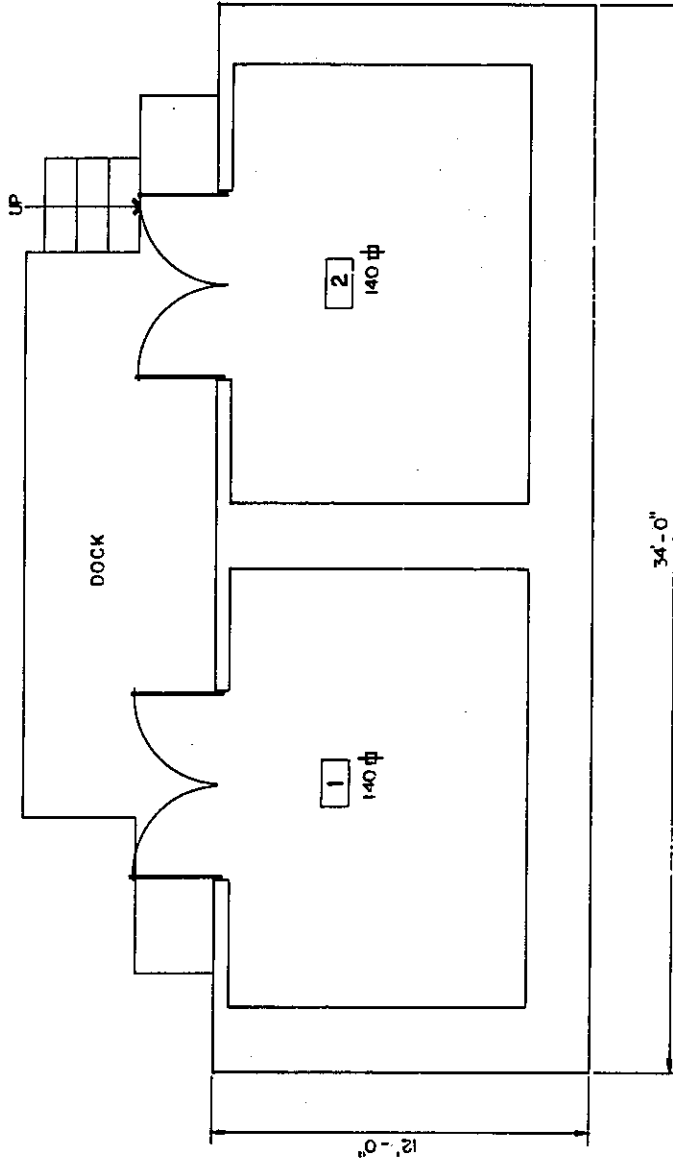

REV.	DATE	DESCRIPTION	BY	APP.
1	8-24-83	REDRAWN & REVISED TO STATUS OF AUGUST 24, 1983	H&N	ETP
UNIVERSITY OF CALIFORNIA				
<b>Los Alamos</b> Los Alamos National Laboratory Los Alamos, New Mexico 87545				
FACILITIES ENGINEERING DIVISION				
SEC. CLASSIFICATION				
CLASS. 11				
REVIEWER <i>Blaine</i>				
DATE 9-6-84				
APPROVED <i>W. J. ...</i>				
BLDG. AW-2 TA-B				
SUBMITTED BY <i>Donna ...</i>				
RECOMMENDED <i>Donna ...</i>				
DATE 08-24-83				
SHEET NO. 1 OF 1				
DRAWN BY <i>H&amp;N</i>				
CHECKED BY <i>H&amp;N</i>				
DRAWING NO. ENG-R2611				

1/4" = 1'-0"  
 GRAPHIC SCALE  
 BLDG. TOTAL 280 S.F.

TO UNIT ROOM



**GENERAL NOTES**

1. General notes to be read in conjunction with the specifications.
2. All work to be in accordance with the specifications.
3. All work to be in accordance with the specifications.
4. All work to be in accordance with the specifications.
5. All work to be in accordance with the specifications.

**ELECTRICAL NOTES**

1. All electrical work to be in accordance with the specifications.
2. All electrical work to be in accordance with the specifications.
3. All electrical work to be in accordance with the specifications.
4. All electrical work to be in accordance with the specifications.
5. All electrical work to be in accordance with the specifications.

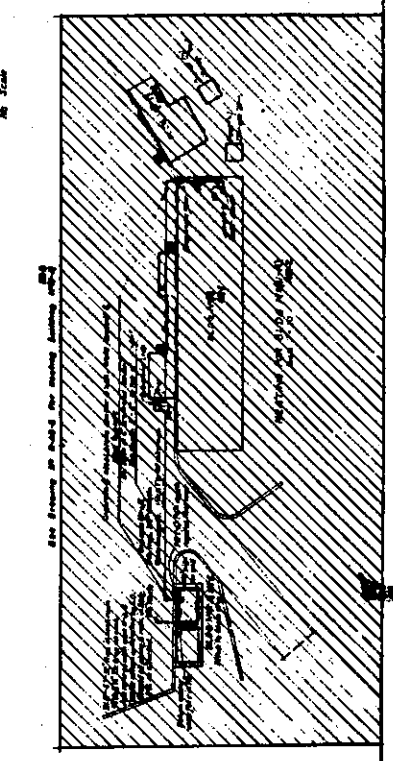
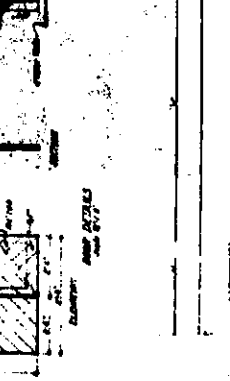
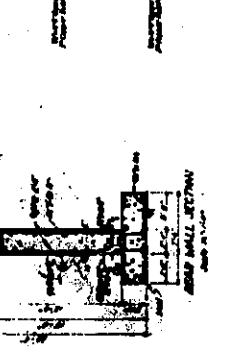
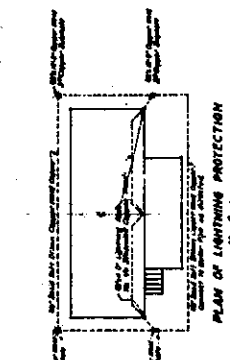
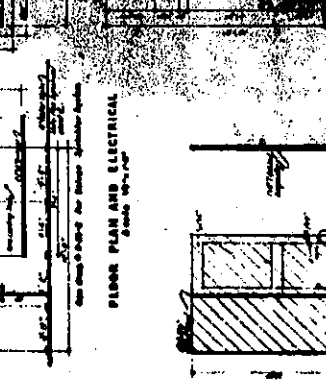
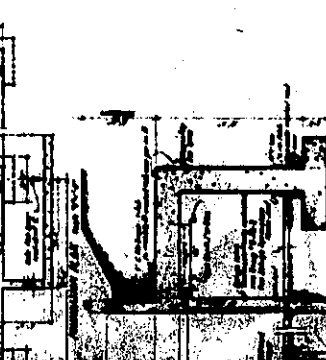
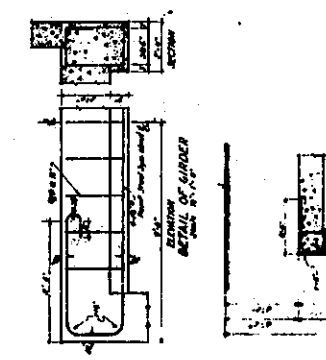
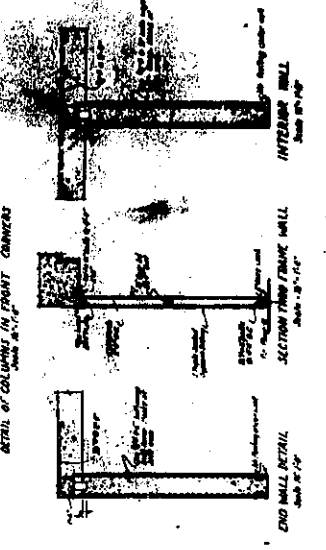
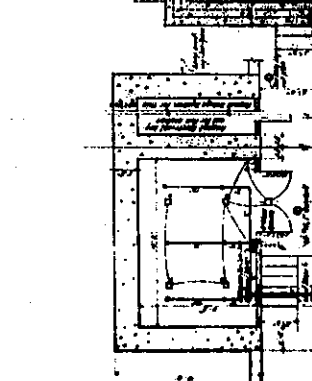
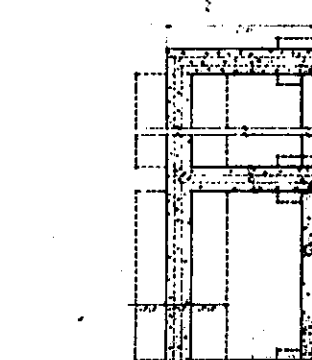
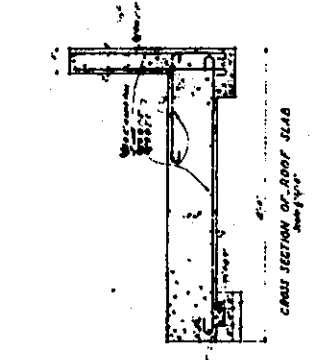
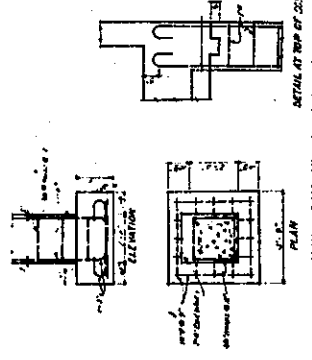

<p>LOS ALAMOS PROJECT - NEW MEXICO          BUILDING NO. 100 (R.A.)          ELECTRICAL &amp; MECHANICAL          DRAWING NO. 100-100-100          DATE: 10/10/50</p>
---

SCALE: 1/8" = 1'-0"



### TA-8-3

**Original Function:** Laboratory  
**Current Function:** Vacant  
**Historical Significance:** Gun Device development and testing in support of “Little Boy” bomb.

**Date Constructed:** 1943  
**Associated Theme:** Gun Device (Atomic Bomb)  
**Eligible?:** Yes – “A” and “C”

#### **Description:**

TA-8-3 is physically attached to the east end of building 8-1; an interior wall partitions the structures. The building is cast-in-place concrete with the original board formwork visible. It is earth-sheltered on the south elevation and the earth continues up onto the structure and creates an earthen roof, topped with vegetation. Entry into the building is on the north side through a wood-frame vestibule attached to the concrete structure. A massive timber and earth filled blast wall stands outside the entry. There are no windows except the light panel in the exterior door. A wood-frame stair leads up the east end of the building onto the dirt roof and provides access to steam utility manholes.

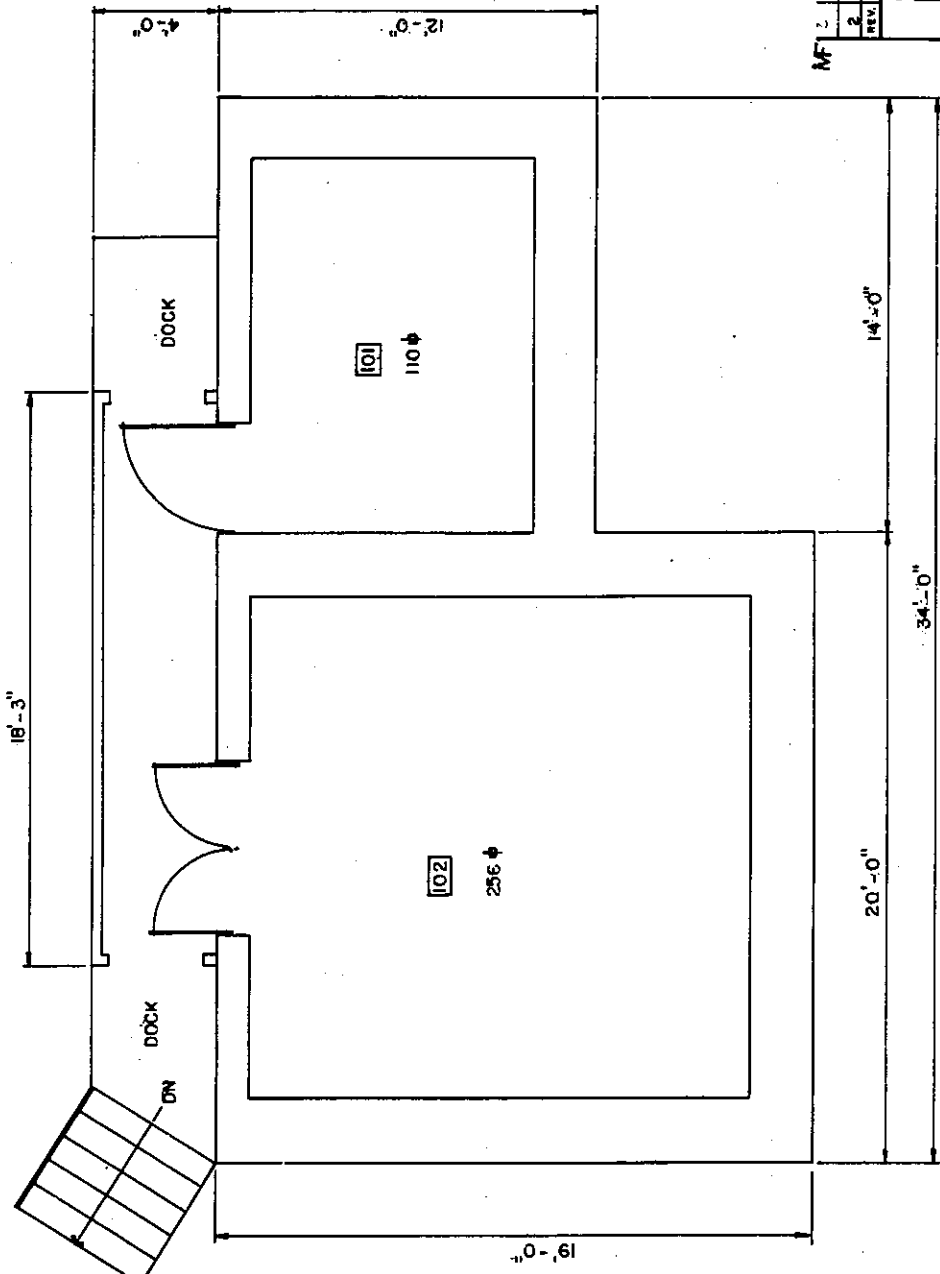

REV.	DATE	REVISION	BY
2	8-25-83	REDRAWN & REVISED TO STATUS OF AUGUST 25, 1983	MAN/STW
UNIVERSITY OF CALIFORNIA			
<b>Los Alamos</b>			
Los Alamos National Laboratory Los Alamos, New Mexico 87545			
FACILITIES ENGINEERING DIVISION			
LABORATORY BLDG. FLOOR PLAN			
BLDG. NO.	RECOMMENDED	DATE	SEC. CLASSIFICATION
AW-23	TA-8	9-2-84	U
DRAWN	DATE	SHEET NO.	REVISION
M. P. N.	08-25-83	1 OF 1	Checked
CHECKED	DATE	DRAWING NO.	DATE
Plumb	14-N	ENG-R2612	9-2-84

1/4" = 1'-0"  
GRAPHIC SCALE  
BLDG. TOTAL 3665.5' ±

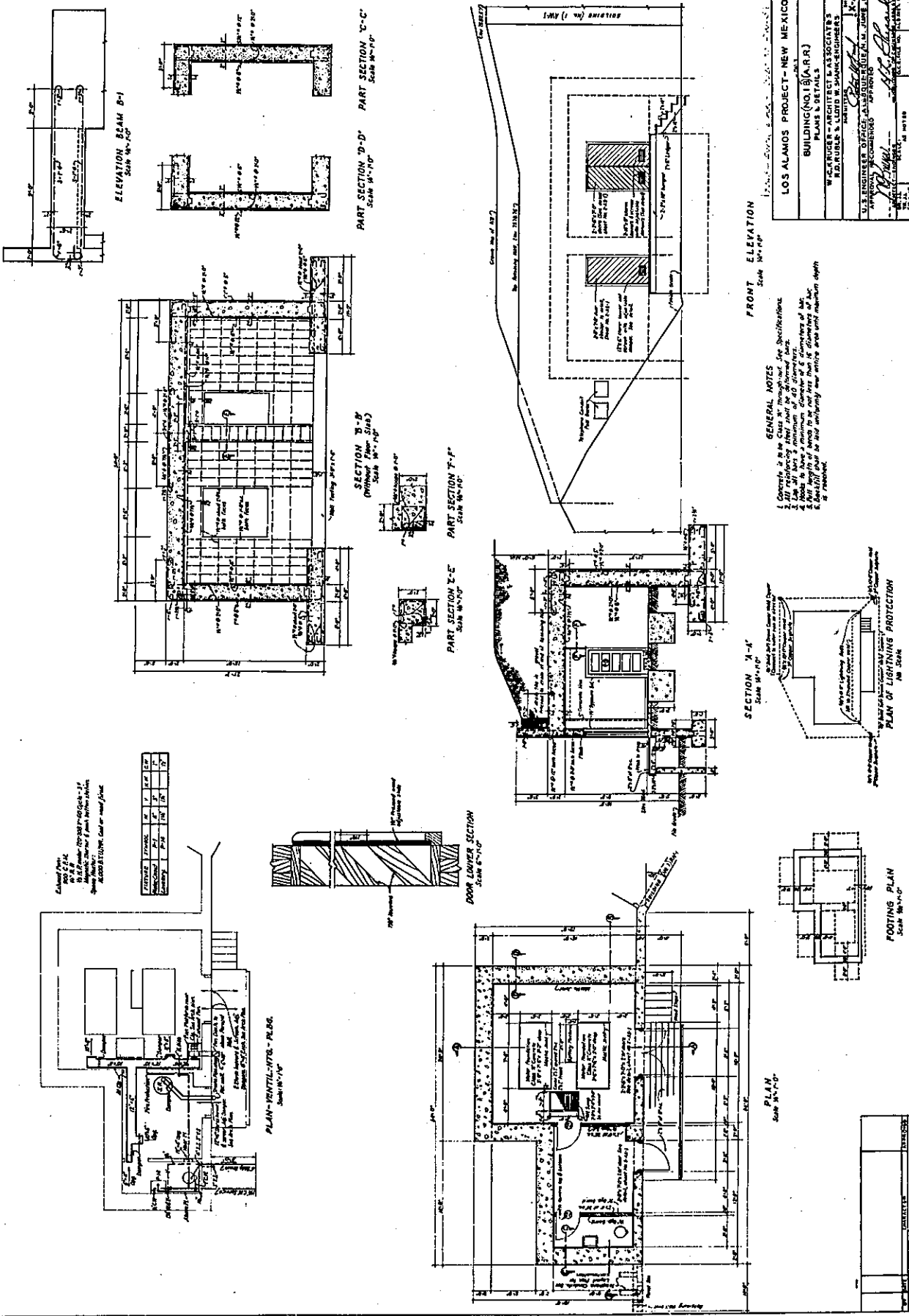

General Note:  
1. Concrete to be Class "B" throughout. See Specifications.  
2. All masonry to be minimum of 8" thickness.  
3. All masonry to have a minimum concrete cover of 2" on all sides.  
4. Reinforcing steel to be uniformly spaced and with maximum depth as indicated.

ITEM	QTY	UNIT	PRICE	TOTAL
CONCRETE	100	CU YD	1.00	100.00
BRICK	1000	SQ YD	0.50	500.00
ROOFING	100	SQ YD	0.25	25.00
PAINT	100	GA	0.10	10.00
IRON	100	LB	0.05	5.00
STEEL	100	LB	0.05	5.00
GLASS	100	SQ FT	0.10	10.00
WOOD	100	CU YD	0.10	10.00
CEMENT	100	CU YD	0.10	10.00
AGGREGATE	100	CU YD	0.10	10.00
PIPE	100	LINEAL FT	0.10	10.00
VALVE	100	EA	0.10	10.00
WATER TIGHTENING	100	SQ YD	0.10	10.00
INSULATION	100	SQ YD	0.10	10.00
SPROUTING	100	SQ YD	0.10	10.00
PAVING	100	SQ YD	0.10	10.00
GRASS	100	SQ YD	0.10	10.00
LANDSCAPING	100	SQ YD	0.10	10.00
UTILITIES	100	SQ YD	0.10	10.00
CONCRETE	100	CU YD	0.10	10.00
BRICK	1000	SQ YD	0.50	500.00
ROOFING	100	SQ YD	0.25	25.00
PAINT	100	GA	0.10	10.00
IRON	100	LB	0.05	5.00
STEEL	100	LB	0.05	5.00
GLASS	100	SQ FT	0.10	10.00
WOOD	100	CU YD	0.10	10.00
CEMENT	100	CU YD	0.10	10.00
AGGREGATE	100	CU YD	0.10	10.00
PIPE	100	LINEAL FT	0.10	10.00
VALVE	100	EA	0.10	10.00
WATER TIGHTENING	100	SQ YD	0.10	10.00
INSULATION	100	SQ YD	0.10	10.00
SPROUTING	100	SQ YD	0.10	10.00
PAVING	100	SQ YD	0.10	10.00
GRASS	100	SQ YD	0.10	10.00
LANDSCAPING	100	SQ YD	0.10	10.00
UTILITIES	100	SQ YD	0.10	10.00

**GENERAL NOTES**

- Concrete to be Class "B" throughout. See Specifications.
- All masonry to be minimum of 8" thickness.
- All masonry to have a minimum concrete cover of 2" on all sides.
- Reinforcing steel to be uniformly spaced and with maximum depth as indicated.

LOS ALAMOS PROJECT - NEW MEXICO  
BUILDING NO. 18 (A.R.R.)  
PLANS & DETAILS

W. C. RICE - ARCHITECT & ASSOCIATES  
R. D. RUBLE & LUDWIG SPAHN-ENGINEERS

U.S. ENGINEER OFFICE  
ALBUQUERQUE, N.M.

APPROVED: [Signature]  
DATE: [Date]

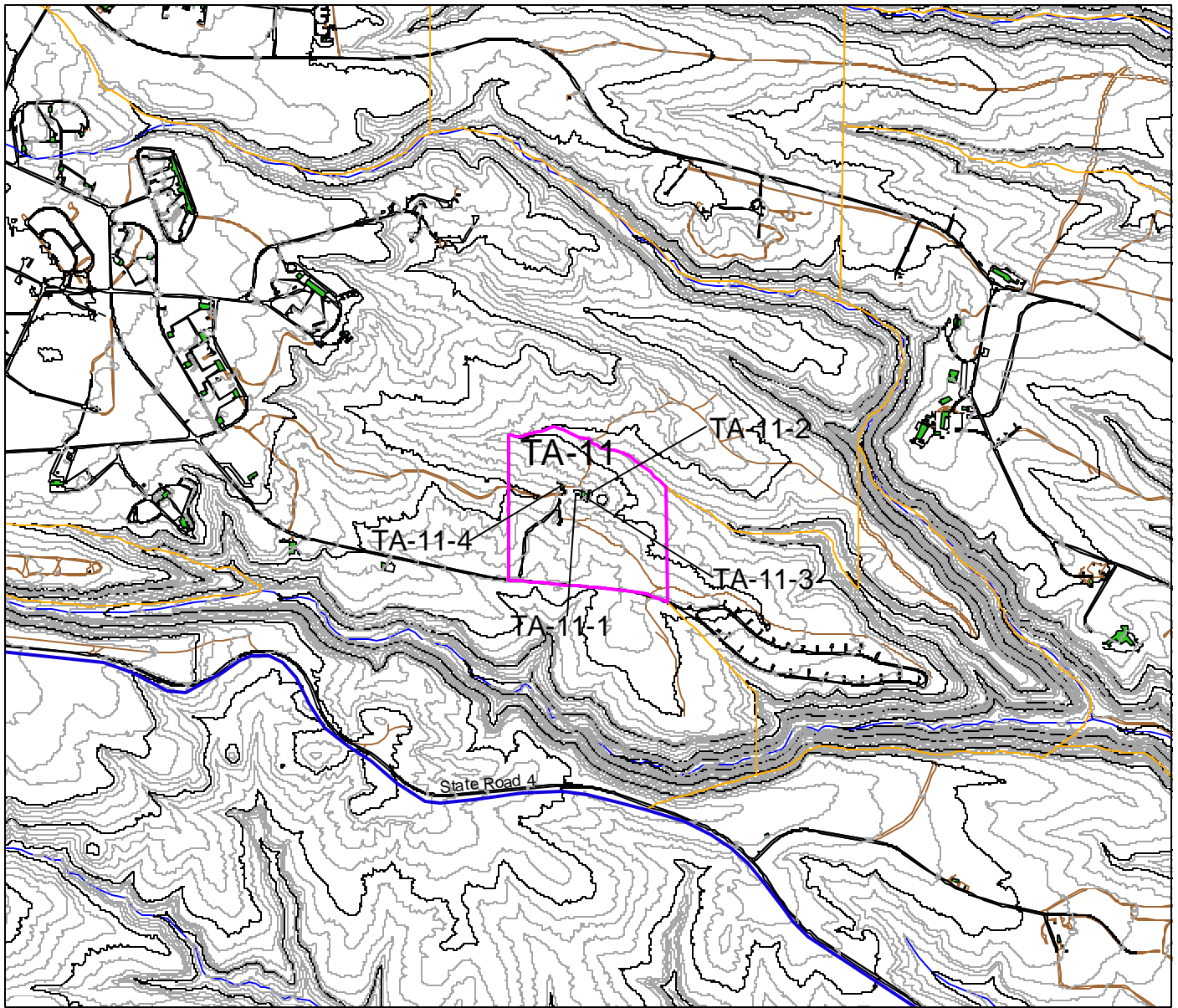

Frijoles Quad

# Los Alamos National Laboratory

Cultural Resources Management Team  
RRES-ECO Ecology Group

1:24000

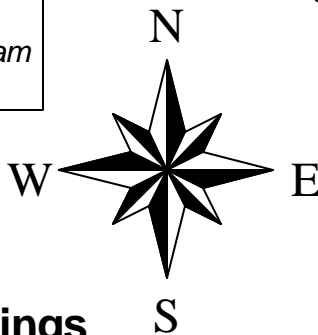
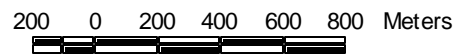
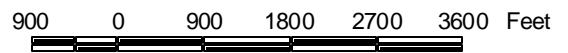

## Manhattan Project Buildings

## TA-11

- Manhattan Project Buildings
- Los Alamos National Laboratory
- Tech Area 11
- Tech Areas
- 20 Foot Contours
- 100 Foot Contours
- Drainage
- Township, Section, Range
- USGS 7.5 Minute Quad
- Roads
- Road/dirt
- Park/pave
- Park/dirt
- Buildings/Structures

Map 9

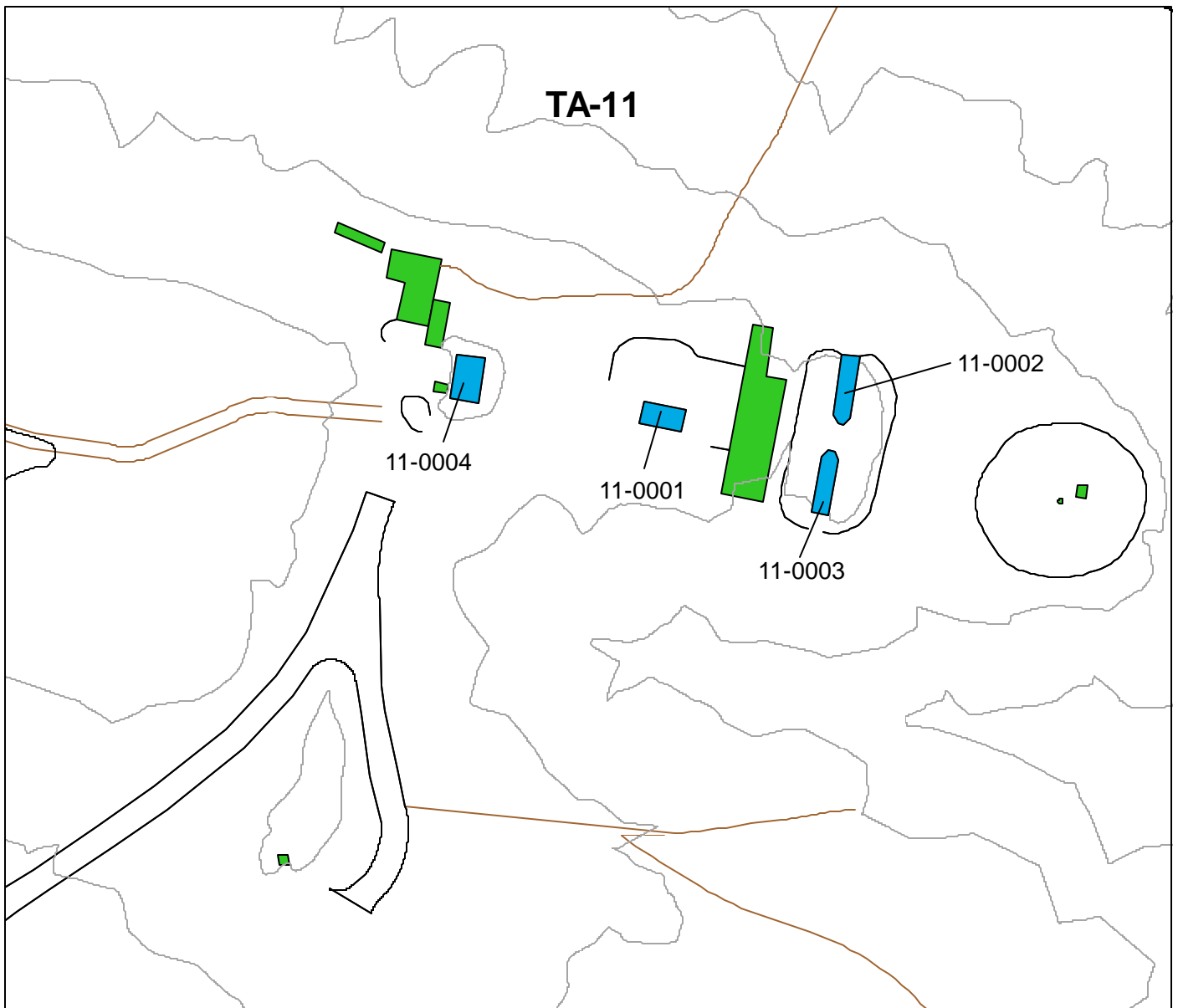

Frijoles Quad

**Los Alamos  
National Laboratory**

*Cultural Resources Management Team  
RRES-ECO Ecology Group*

1:1500

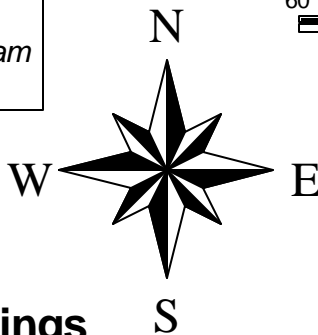
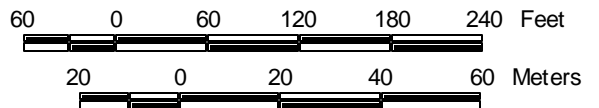

**Manhattan Project Buildings**

**TA-11  
Closeup**

- Manhattan Project Buildings
- Los Alamos National Laboratory
- Tech Area 11
- Tech Areas
- 20 Foot Contours
- 100 Foot Contours
- Drainage
- Township, Section, Range
- USGS 7.5 Minute Quad
- Roads
- Roaddirt
- Parkpave
- Buildings/Structures

Map 10





### TA-11-1

**Original Function:** Control Laboratory

**Date Constructed:** 1944

**Current Function:** Storage Building

**Associated Theme:** Implosion

**Historical Significance:** Betatron diagnostic studies in support of spherical implosion research.

**Eligible?:** Yes – “A”

### **Description:**

Building TA-11-1 is one story in height and rectangular in plan. The structure measures 19 ft by 32 ft 6 in., excluding the protruding wing walls. The single-room interior contains 480 ft<sup>2</sup> of floor space. The structure was constructed with board-formed heavily reinforced concrete walls and flat roof and isolated floor. A compacted earth berm covers the north, east, and south sides and the roof of the building for added protection. A concrete entrance pad, an entry door, and an exhaust vent are located on the exposed west side of the building. The entry door is a steel-frame wood plank door with heavy-duty strap hinges and a steel lever door handle. Reinforced concrete retaining walls with aluminum flashing, constructed perpendicular to the entry wall, angle down from the roof level of the structure to grade level.

The control room floor was constructed with reinforced concrete footings and a 10 in. reinforced concrete slab over a layer of sawdust, sand, and compacted earth. The walls and roof were also constructed of reinforced concrete and finished with two coats of dust-proof enamel. Floor trenches, measuring 8 in. by 12 in., were constructed into the concrete floor and lined with galvanized sheet metal. An isolated concrete pad, located in the northeast corner of the control room, supported the transformer.

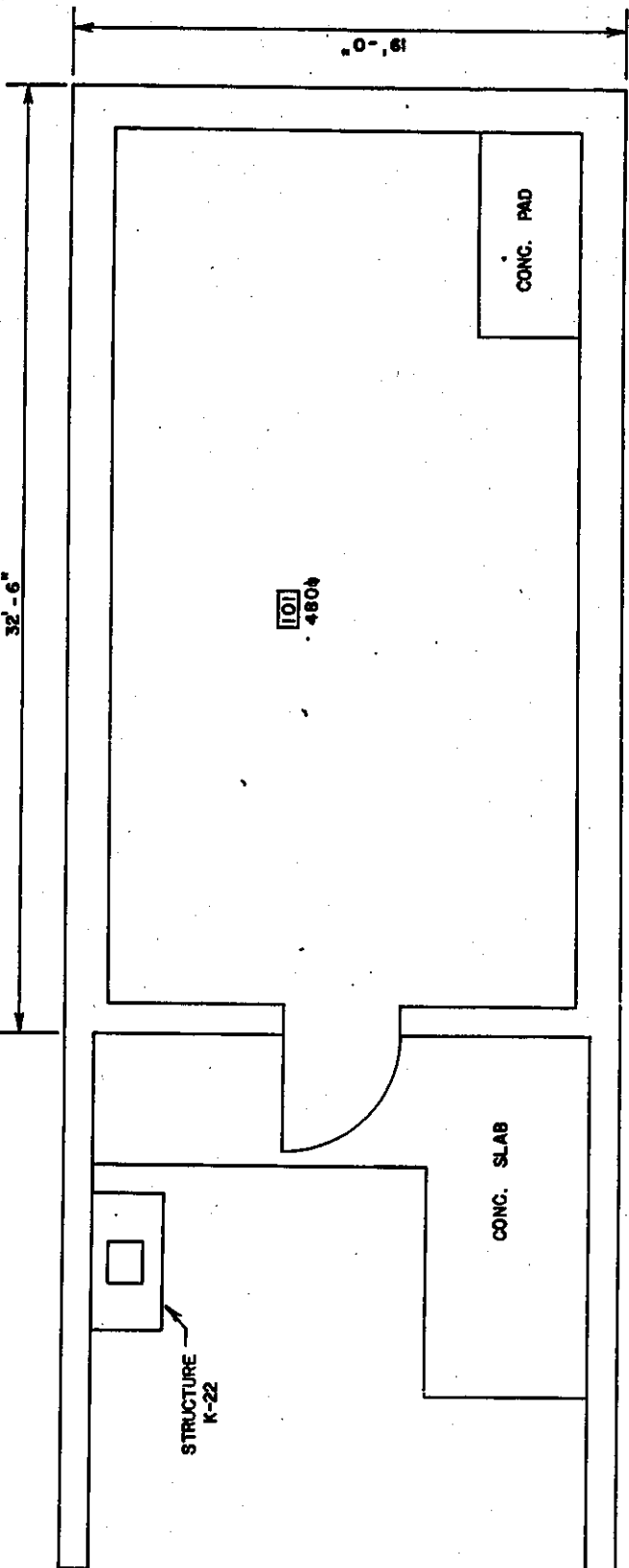

REV.	DATE	DESCRIPTION	BY	CHK
1	8-30-83	REDRAWN AND REVISED TO STATUS OF 8-30-83	W.A.P.	J.P.
UNIVERSITY OF CALIFORNIA <b>LOS ALAMOS</b> Los Alamos National Laboratory Los Alamos, New Mexico 87545				
FACILITIES ENGINEERING DIVISION			REG. CLASSIFICATION	
STORAGE BUILDING FLOOR PLAN			SLAB	4
BLDG. K-1			REVISOR	W.A.P.
TA-II			DATE	5.6.82
DESIGNED BY J. Kennedy		REVIEWED BY W.A.P.	DRAWN BY W.A.P.	
DATE 8-30-83	SHEET NO. 1 OF 1	ENGINEER IN CHARGE W.A.P.		
REC'D LOGGED TO VAULT				



GRAPHIC SCALE

TOTAL SQ. FT. 480





TA-11-2

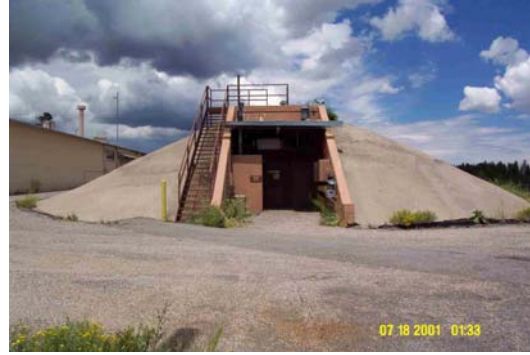

TA-11-3

TA-11-2 and TA-11-3

**Original Function:** Betatron and Cloud Chamber  
**Current Function:** Control Buildings  
**Historical Significance:** Betatron diagnostic studies in support of spherical implosion research.

**Date Constructed:** 1944  
**Associated Theme:** Implosion  
**Eligible?:** Yes – “A” and “C”

**Description:**

TA-11-2 and TA-11-3 are two former laboratory buildings located back-to-back at K Site. Both structures are one story in height and rectangular in plan, with a pointed end at the back side of the building. The structures were constructed with a heavily reinforced concrete foundation over sawdust and sand layers, concrete walls, and a flat concrete roof. The sidewalls of both structures thicken from 1 ft to 3 ft along the length until they terminate at a point. A 16 in. outside diameter steel pipe, located at the point, connects the two buildings together. Both the east and west sides and the roofs of the buildings are covered with compacted earth and a layer of asphalt giving the appearance of a single reinforced structure. The interior of both buildings consists of a single open room constructed with a reinforced concrete floor, walls, and ceiling. Both rooms are equipped with surface mounted conduit, HVAC ductwork, and light fixtures. A cable tray was used to house the numerous mechanical, electrical, and communication cables that spanned between the two structures.

Building TA-11-2 (Betatron): The entrance into the building is from the north side. The original steel-frame wood plank entry door was set into the exposed concrete wall flanked by two reinforced concrete angled wing walls. In 1947, the entrance and wing walls into building TA-11-2 were enclosed and equipped with chain-link partitions. A new concrete floor was installed along with 2 in. by 4 in. stud walls and ½ in. gypsum board on the interior. A shed roof was constructed with 2 in. by 6 in. rafters and roofing concrete. The entrance was renovated and the exterior covered with square seam metal siding and the roof was covered with rolled asphalt roofing material. The new entry door consists of a pair of metal doors set flush within the steel frame wall.

Building TA-11-3 (Cloud Chamber): Entry into the building is from the south side. The entrance consists of a steel-frame wood plank entry door, with strap hinges and lever latch, set into the exposed concrete wall and flanked by two reinforced concrete angled wing walls. A small toilet room is located adjacent to the entrance door on the exterior of the structure. A concrete roof extends over the entry area and is equipped with a steel observation tower accessed by steps on the southwest side. A one-ton crane is suspended from a steel crossbeam.

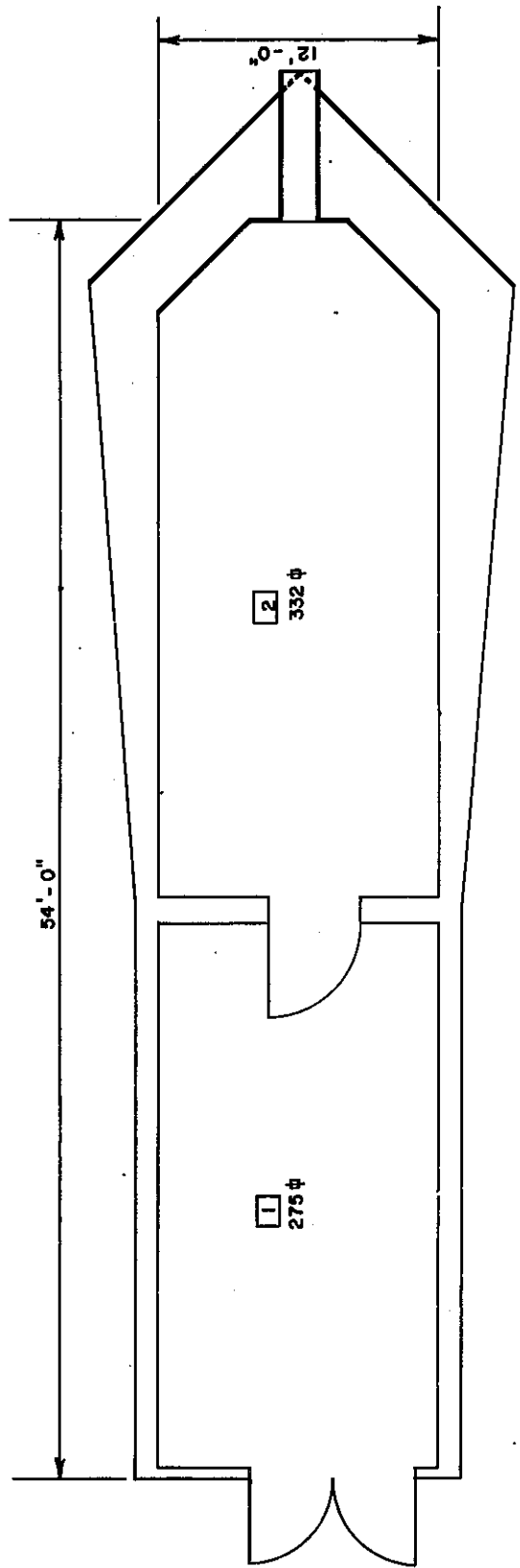
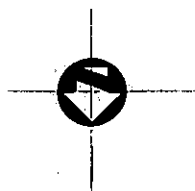

MF	2	8-31-83	REDRAWN AND REVISED TO STATUS OF 8-31-83	HAN	8/31/83
	REV.	DATE	REVISION	BY	DATE
UNIVERSITY OF CALIFORNIA			Los Alamos National Laboratory Los Alamos, New Mexico 87545		
<b>Los Alamos</b>			FACILITIES ENGINEERING DIVISION		
CONTROL BUILDING			SEC. CLASSIFICATION		
FLOOR PLAN			CLASS. <i>14</i>		
BLDG. K-2			DATE <i>9-6-86</i>		
PROJECT <i>TA-11</i>			DRAWN BY <i>W. J. Elbert</i>		
CHECKED <i>Kenelle Han</i>			DATE <i>8-31-83</i>		
DESIGNED <i>Kenelle Han</i>			SHEET NO. <i>1</i> OF <i>1</i>		
			DRAWING NO. <i>ENG-R2885</i>		



GRAPHIC SCALE

TOTAL SQ. FT. 607





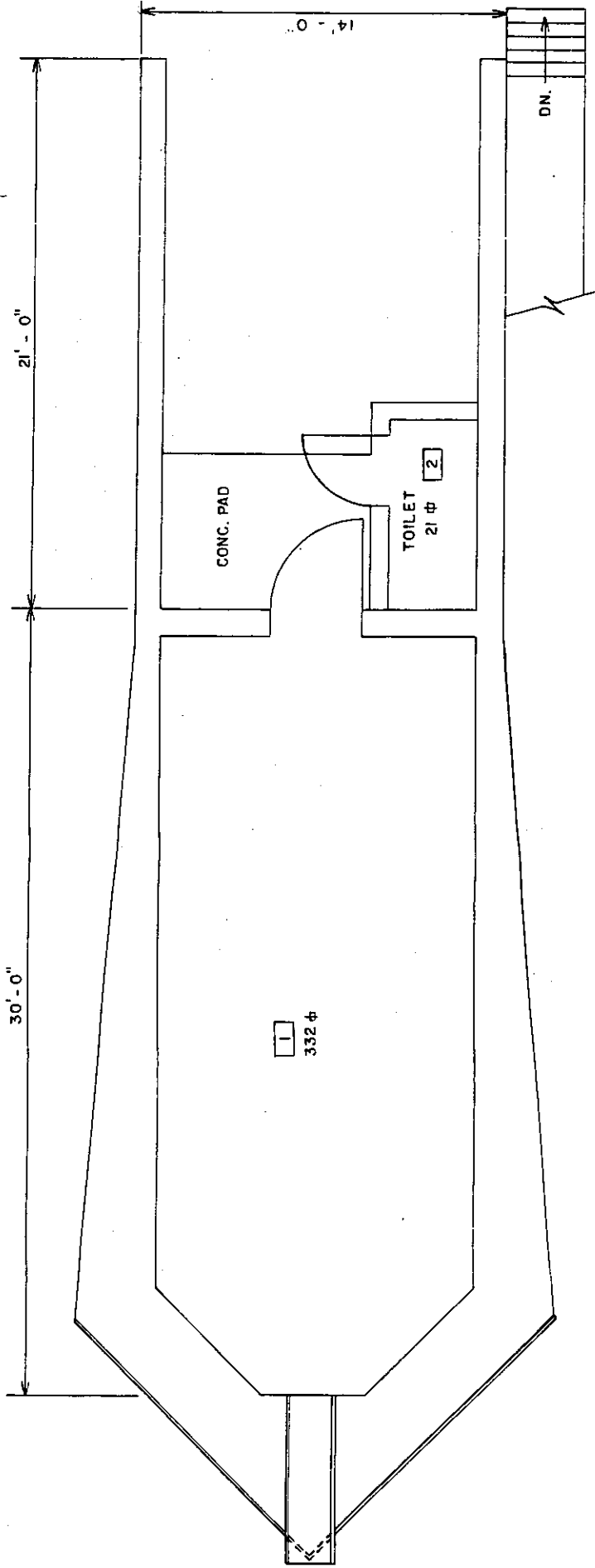

REV.	DATE	REVISION	BY	CHK.
3	2-6-84	REVISED TO STATUS OF 2-6-84	HAN	HAN
2	8-31-83	REDRAWN & REVISED TO STATUS OF 8-31-83	HAN	HAN

UNIVERSITY OF CALIFORNIA  
**Los Alamos**  
 Los Alamos National Laboratory  
 Los Alamos, New Mexico 87545

FACILITIES ENGINEERING DIVISION  
 CONTROL BUILDING  
 FLOOR PLAN  
 BLDG. K-3  
 TA-II

SUBMITTED BY <i>G. Traylor</i>	RECOMMENDED BY <i>D. ...</i>	APPROVED BY <i>R.H. ...</i>
DRAWN G. MARTINEZ	DATE 8-31-83	HEET NO. 1
CHECKED <i>Humbert HAN</i>	DATE 8-31-83	DRAWING NO. ENG-R 2686

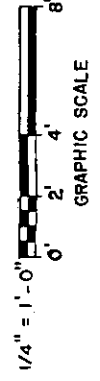

MF

TOTAL  $\frac{ft^2}{353}$

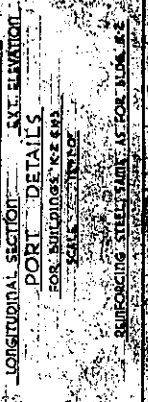
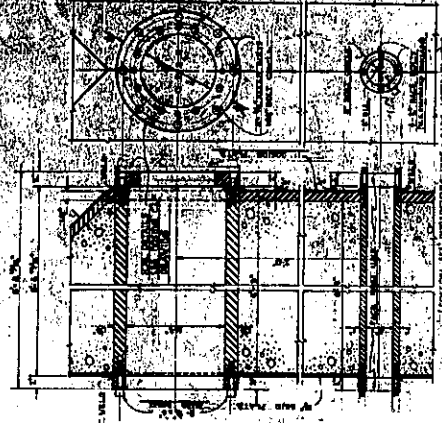
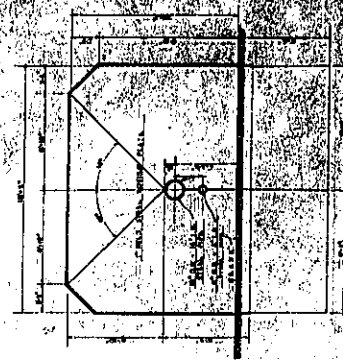
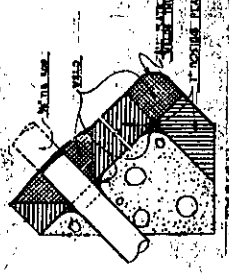
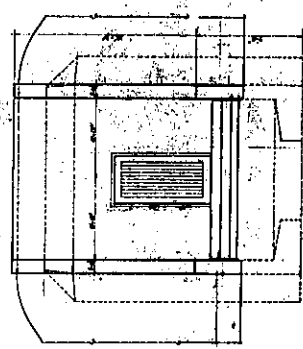
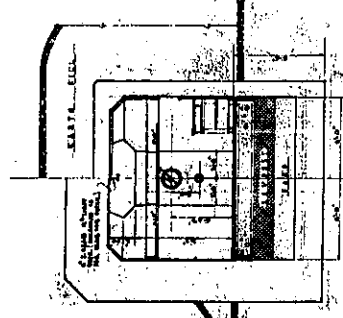
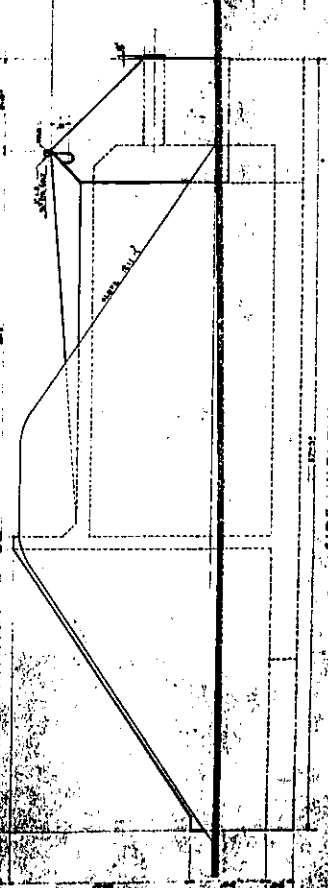
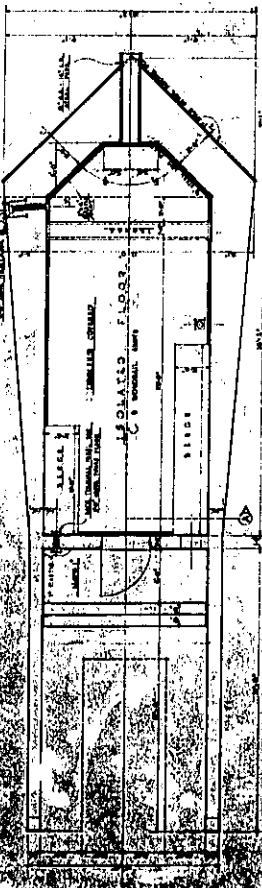
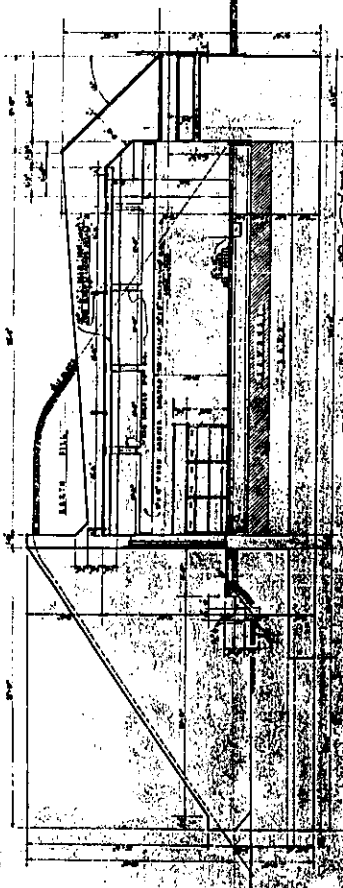

REINFORCING STEEL PLAN FOR BULK HEAD

REVISIONS

NO.	DATE	DESCRIPTION
1	10/15/50	ISSUED FOR CONSTRUCTION
2	11/15/50	REVISED FOR CONSTRUCTION

REVISIONS

NO.	DATE	DESCRIPTION
1	10/15/50	ISSUED FOR CONSTRUCTION
2	11/15/50	REVISED FOR CONSTRUCTION

REVISIONS

NO.	DATE	DESCRIPTION
1	10/15/50	ISSUED FOR CONSTRUCTION
2	11/15/50	REVISED FOR CONSTRUCTION

REVISIONS

NO.	DATE	DESCRIPTION
1	10/15/50	ISSUED FOR CONSTRUCTION
2	11/15/50	REVISED FOR CONSTRUCTION

REVISIONS

NO.	DATE	DESCRIPTION
1	10/15/50	ISSUED FOR CONSTRUCTION
2	11/15/50	REVISED FOR CONSTRUCTION



#### TA-11-4

**Original Function:** Shop/Implosion Imaging  
**Current Function:** Control Building  
**Historical Significance:** Betatron diagnostic studies in support of spherical implosion research.

**Date Constructed:** 1944  
**Associated Theme:** Implosion  
**Eligible?:** Yes – “A”

#### **Description:**

Building TA-11-4 was constructed as a one-story structure, approximately square in plan, and measuring 32 ft by 22 ft, excluding the protruding retaining walls. The structure was constructed with a reinforced concrete post and pier foundation, 2 in. by 12 in. wood floor joists, 2 in. by 10 in. wood stud walls, and slightly pitched 2 in. by 12 in. wood rafter shed roof. All exterior surfaces are covered with 2 in. wood sheathing and two layers of asphalt-mopped felt. Three sides of the structure and the roof are covered with compacted earth for added blast protection. The double-door entrance is located on the west side and framed with wood studs and sheathing. Ten-inch-diameter posts and angled 2 in. by 10 in. bulkhead planks were used to construct the two retaining walls. The interior was originally divided into a shop area, a dark room with light lock, and a toilet room.

In 1958, the building was converted into a control room for the High Explosives Vibration Test Facility (TA-11-30). The shop area, dark room, and light lock were removed, and new control panels and power supplies were installed. The original wood floor was removed and a 6 in. concrete slab floor installed. The original double metal doors with transom were reused during the renovation process. In 1962, the building underwent a second renovation. The original interior wood columns were removed and the top of the original floor piers removed. A new steel frame structure was installed around the original building and back-filled with earth. The entry area was re-sheathed with square seam metal siding on 3 ft concrete stem walls. The entry doors were replaced with a pair of hollow metal doors with small lights. The interior was equipped with surface mounted conduit, HVAC ductwork, and light fixtures. New control equipment and air handling units were installed in the mid 1980s.

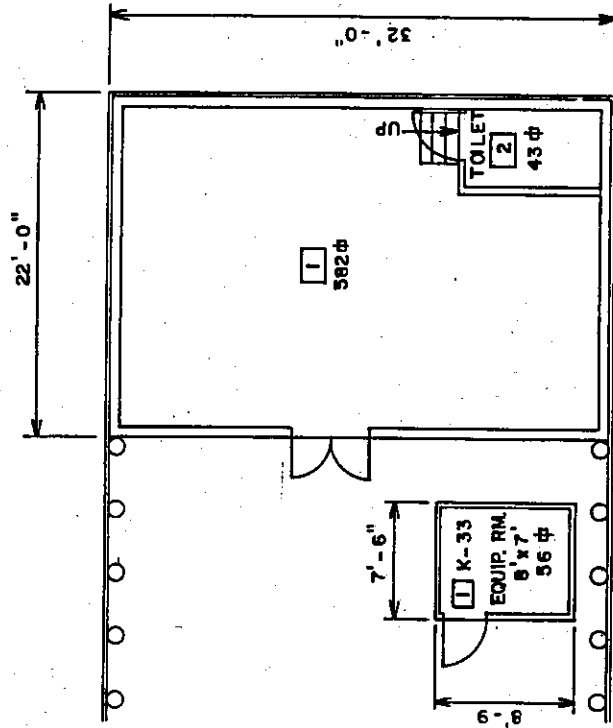

BLDG. K-33 TOTAL 112  
 56  
 112

BLDG. K-4 TOTAL 625  
 625

REV.	DATE	REVISION	BY	CHK.
2	8-30-83	REDRAWN & REVISED TO STATUS OF 8-30-83	HNH	HNH
UNIVERSITY OF CALIFORNIA <b>Los Alamos</b> Los Alamos National Laboratory Los Alamos, New Mexico 87545				
FACILITIES ENGINEERING DIVISION			SEC. CLASSIFICATION	
CONTROL BLDG. & EQUIPMENT RM.			CLASS. <i>SECRET</i>	
FLOOR PLAN			REVISED BY <i>HNH</i>	
BLDG. K-4 & K-33			DATE 7-2-80	
TA-II			APPROVED BY <i>HNH</i>	
DESIGNED BY <i>HNH</i>	RECOMMENDED BY <i>HNH</i>	DATE 8-30-83	SHEET NO. 1	OF 1
DRAWN BY <i>HNH</i>	CHECKED BY <i>HNH</i>	DATE 8-30-83	DRAWING NO. ENG-R 2687	

MF

sh. 1.

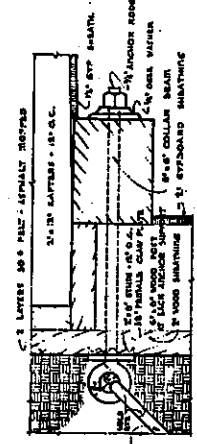
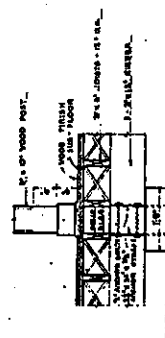
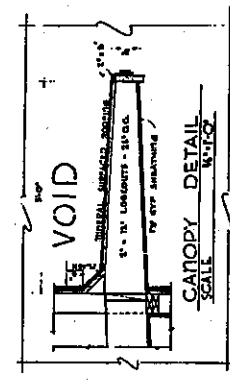
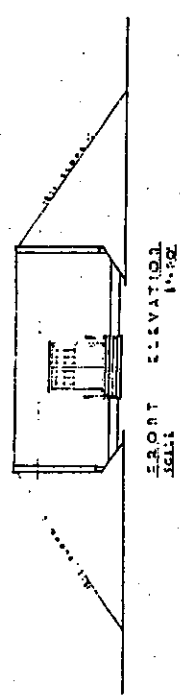
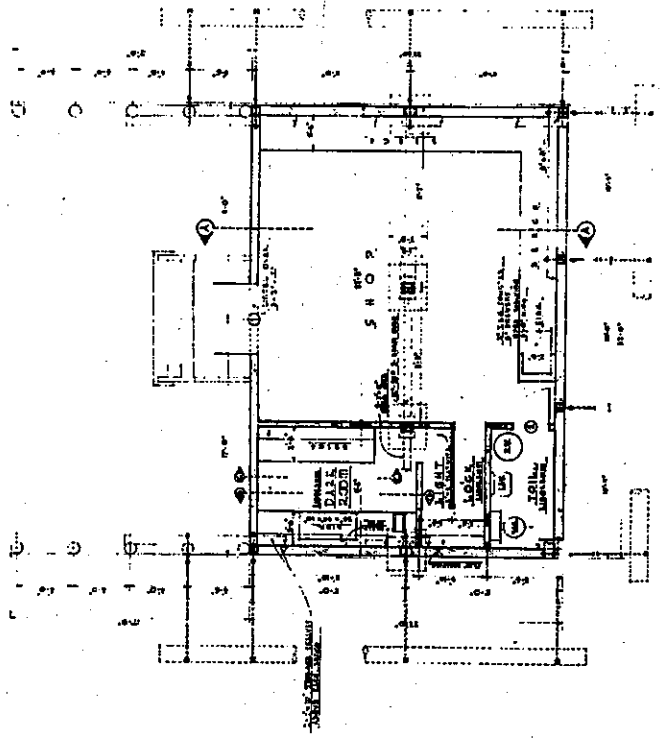

NOTE: THIS DRAWING IS THE PROPERTY OF THE ARCHITECT AND SHOULD NOT BE REPRODUCED OR TRANSMITTED IN ANY FORM OR BY ANY MEANS, ELECTRONIC OR MECHANICAL, INCLUDING PHOTOCOPYING, RECORDING, OR BY ANY INFORMATION STORAGE AND RETRIEVAL SYSTEM, WITHOUT THE WRITTEN PERMISSION OF THE ARCHITECT.

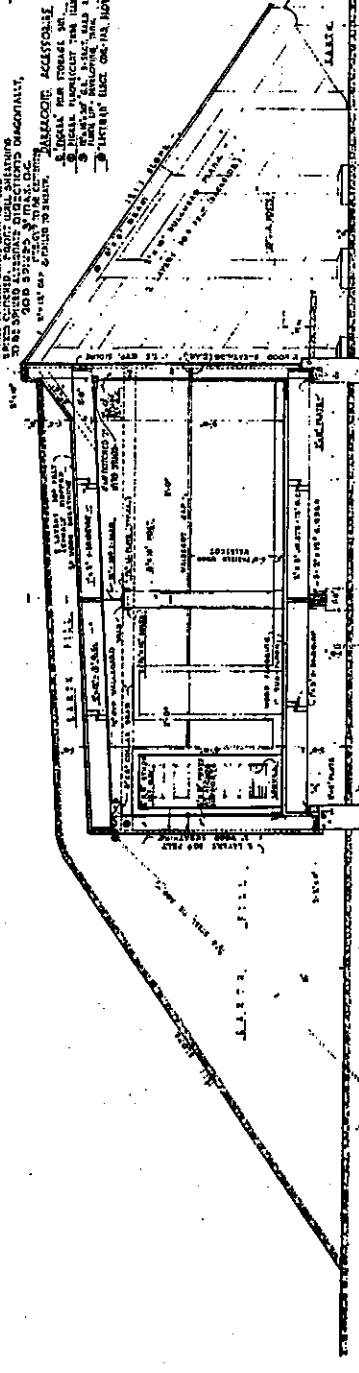
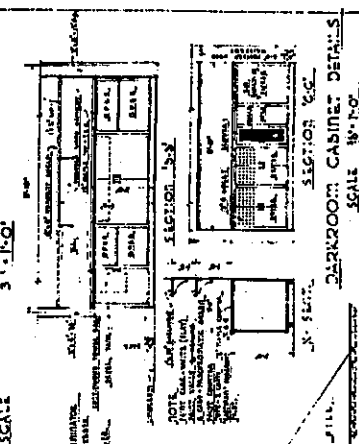

BLDG. K-4 FLOOR PLAN - ELEV. SECTIONS - DET.	PROJECT NO.	1506
VEHICULAR ACCESSORY	CONTRACT NO.	1506
ZIA PROJECT	DATE	11/1/56
K SITE CONSTRUCTION	DESIGNED BY	W. H. HARRIS
U.S. ENGINEER OFFICE	CHECKED BY	W. H. HARRIS
SANTA FE	DATE	11/1/56
NEW MEXICO	SCALE	1/4" = 1'-0"
1506	DATE	11/1/56

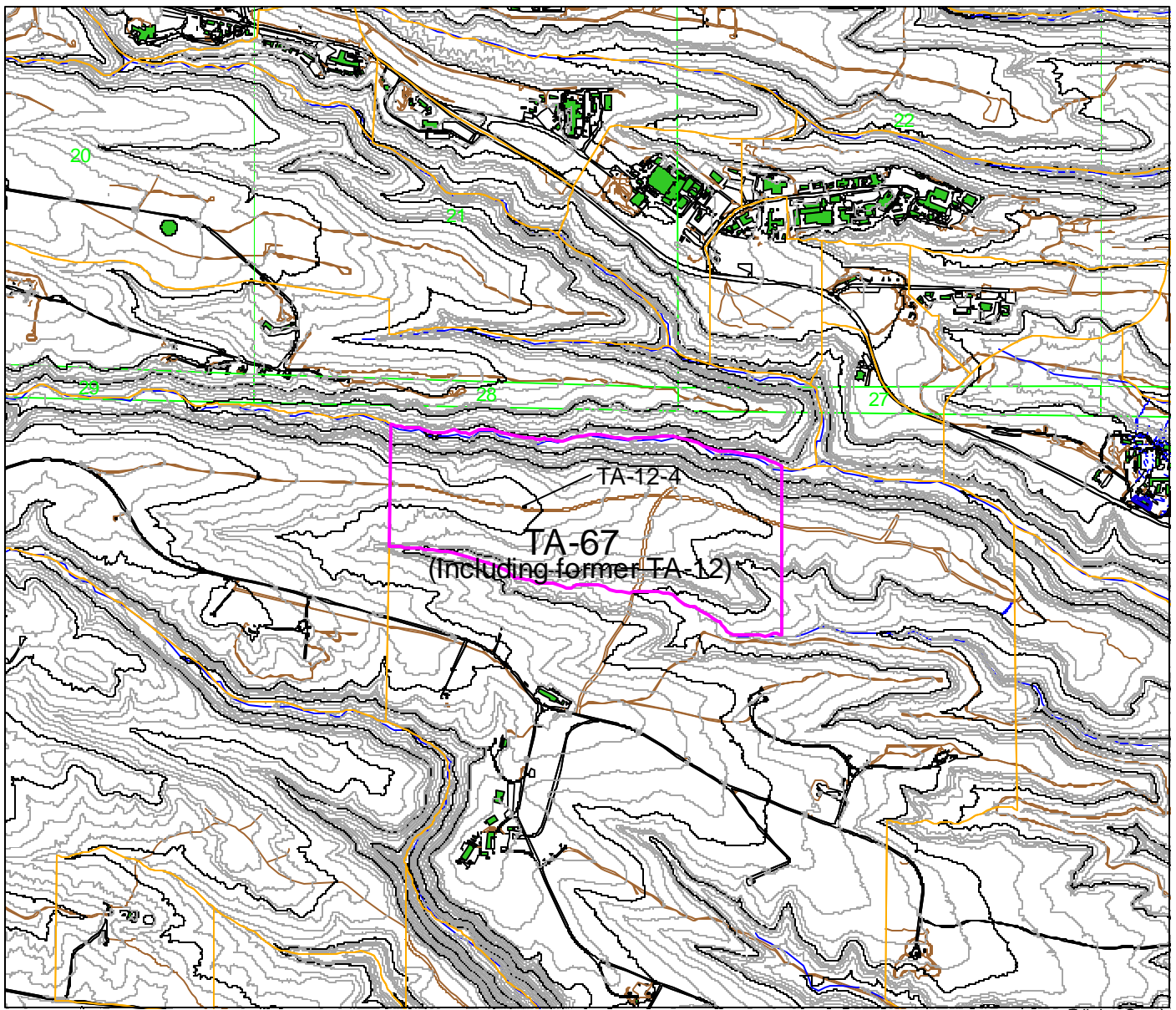

Frijoles Quad

# Los Alamos National Laboratory

Cultural Resources Management Team  
RRES-ECO Ecology Group

1:24000

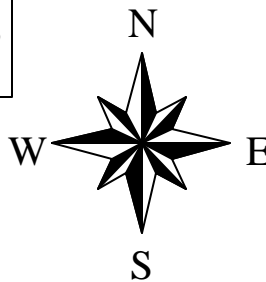

## Manhattan Project Buildings TA-67 (Includes Former TA-12)

- Manhattan Project Structures
- Los Alamos National Laboratory
- Tech Area 67
- Tech Areas
- 20 Foot Contours
- 100 Foot Contours
- Drainage
- Township, Section, Range
- USGS 7.5 Minute Quad
- Roads
- Road/dirt
- Park/pave
- Park/dirt
- Buildings/Structures

Map 11



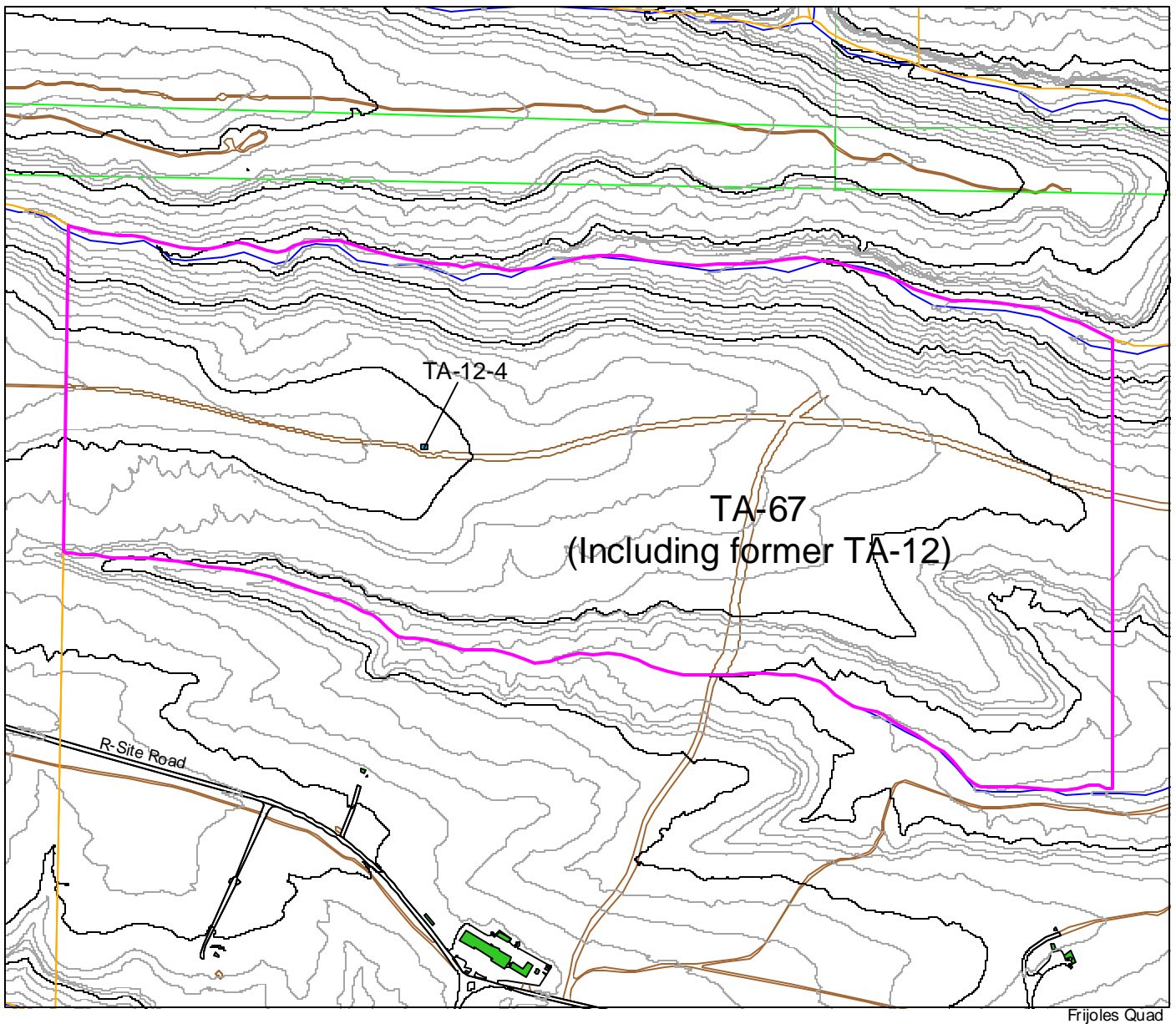

Frijoles Quad

# Los Alamos National Laboratory

Cultural Resources Management Team  
RRES-ECO Ecology Group

1:9000

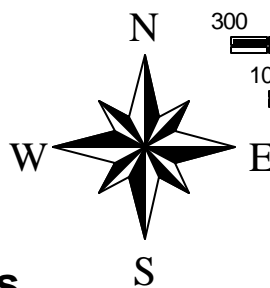
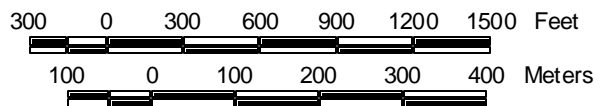

## Manhattan Project Buildings

## TA-67 (Including former TA-12) Closeup

- Manhattan Project Structures
- Los Alamos National Laboratory
- Tech Area 67
- Tech Areas
- 20 Foot Contours
- 100 Foot Contours
- Drainage
- Township, Section, Range
- USGS 7.5 Minute Quad
- Roads
- Roaddirt
- Parkpave
- Parkdirt
- Buildings/Structures

Map 12



#### TA-12-4

**Original Function:** Firing Pit

**Current Function:** Not in Use

**Historical Significance:** High explosives testing in support of implosion (atomic bomb) research.

**Date Constructed:** 1945

**Associated Theme:** Implosion/Recovery

**Eligible?:** Yes – “A”

#### **Description:**

TA-12-4 is a hexagonal firing pit that was constructed of heavy timber for use in explosives testing and recovery experiments. The structure has 8 ft wide sides and is 12 ft deep. The sides and top of the firing structure are lined with three-quarter in. steel plate. The structure stands alone with no supporting buildings and is situated on a human-made earthen mound. TA-12-4 was abandoned in 1953.





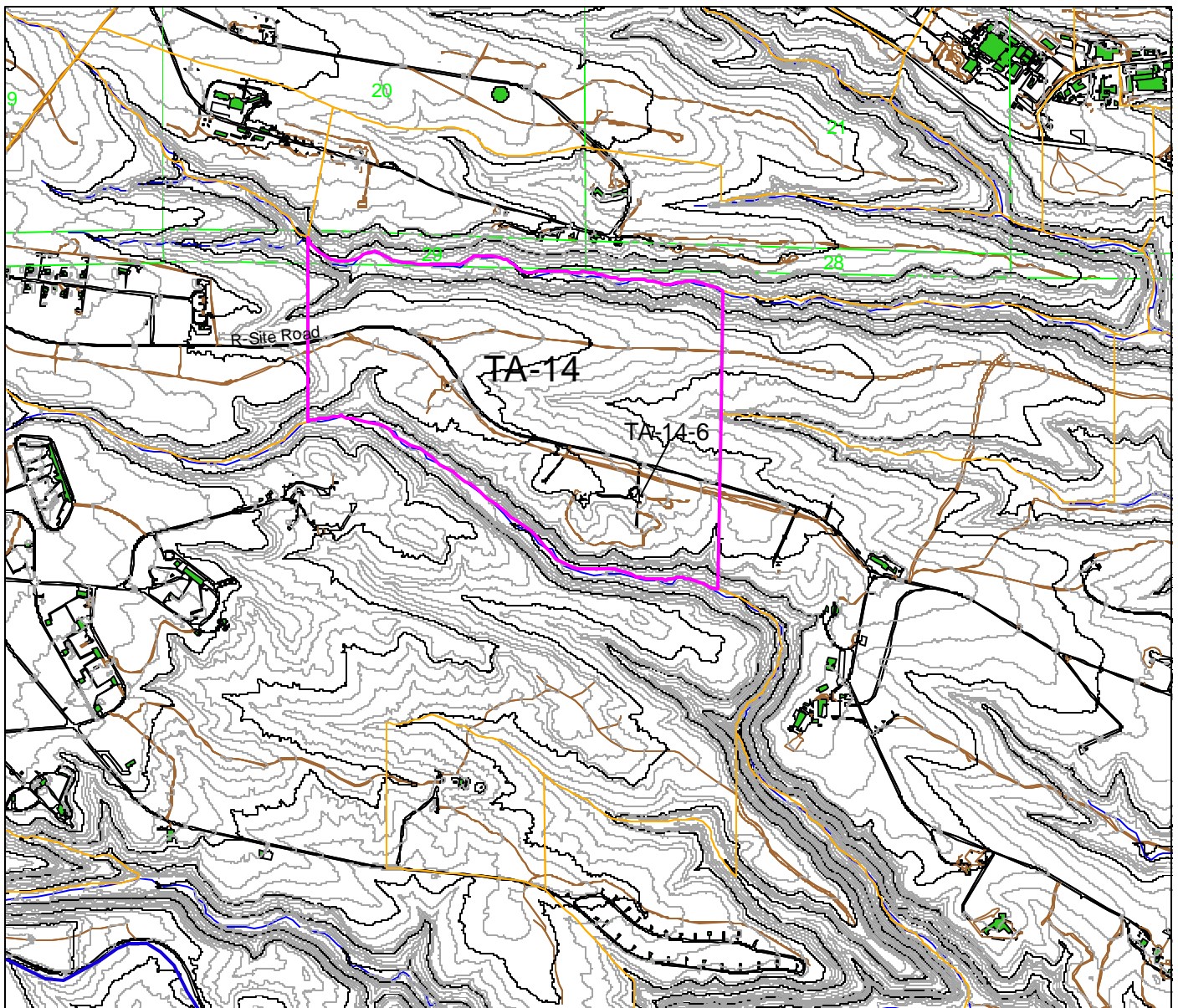

Frijoles Quad

# Los Alamos National Laboratory

Cultural Resources Management Team  
RRES-ECO Ecology Group

1:24000

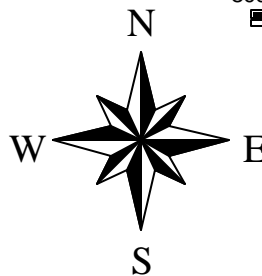
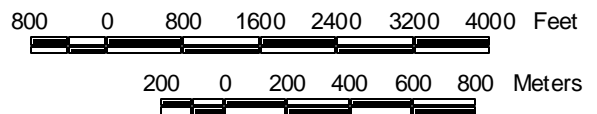

## Manhattan Project Buildings

### TA-14

- Manhattan Project Buildings
- Los Alamos National Laboratory
- Tech Area 14
- Tech Areas
- 20 Foot Contours
- 100 Foot Contours
- Drainage
- Township, Section, Range
- USGS 7.5 Minute Quad
- Roads
- Road/dirt
- Park/pave
- Park/dirt
- Buildings/Structures

Map 13

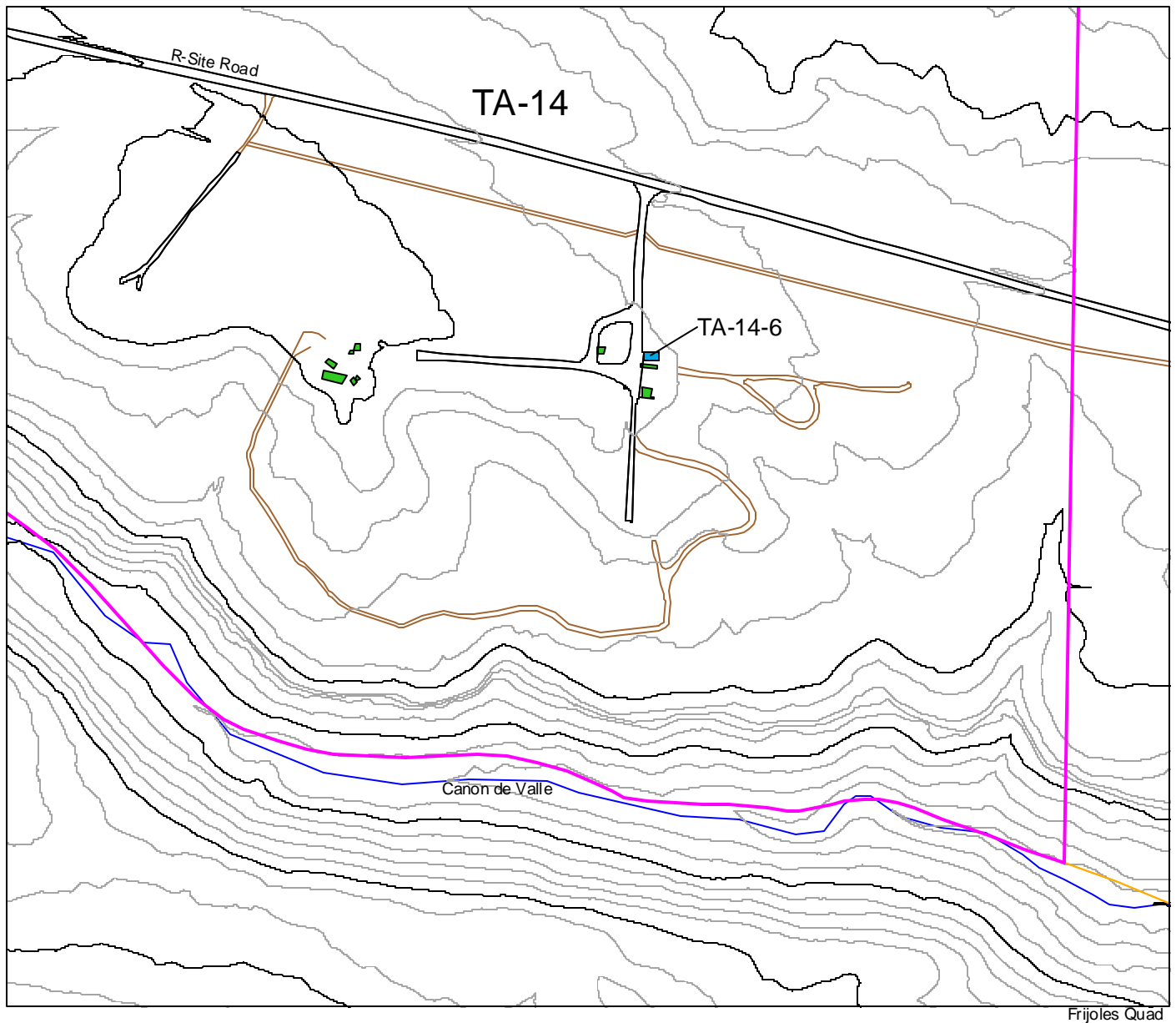

Frijoles Quad

**Los Alamos**  
**National Laboratory**  
*Cultural Resources Management Team*  
*RRES-ECO Ecology Group*

1:4440

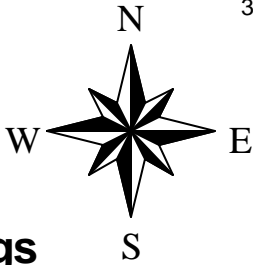

### Manhattan Project Buildings

### TA-14 Closeup

- Manhattan Project Buildings
- Los Alamos National Laboratory
- Tech Area 3
- Tech Areas
- 20 Foot Contours
- 100 Foot Contours
- Drainage
- Township, Section, Range
- USGS 7.5 Minute Quad
- Roads
- Roaddirt
- Parkpave
- Parkdirt
- Buildings/Structures

Map 14





### TA-14-6

**Original Function:** Shop and Dark Room

**Current Function:** Storage Building

**Historical Significance:** Small-scale implosion studies supported implosion bomb, “Fat Man” research.

**Date Constructed:** 1944

**Associated Theme:** Implosion

**Eligible?:** Yes – “A”

### **Description:**

TA-14-6 is a small, wood-frame building built on a concrete foundation and slab. The wood structure incorporates asphalt impregnated paper with wood sleepers and asbestos shingles. The roof is wood frame, low slope with numerous layers of rolled roofing material. The north elevation shows three wood-frame, hopper-style windows with four-over-four window lights. The entry door is raised panel wood in a wood frame. Two double doors, which are modern replacements, are seen on two other elevations.

36'-8"

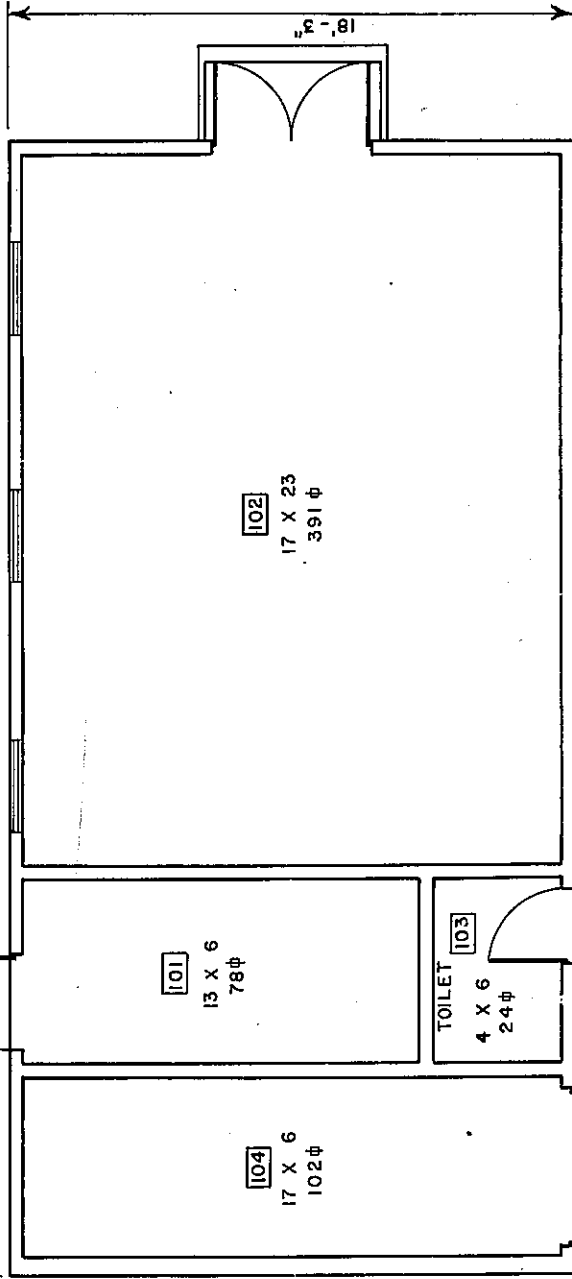

102  
17 X 23  
391 φ

101  
13 X 6  
78 φ

TOILET 103  
4 X 6  
24 φ

104  
17 X 6  
102 φ



TOTAL SQ. FT. 595

REV.	1	8-30-83	REDRAWN AND REVISED TO STATUS OF 8-30-83	HN	SH
		DATE	REVISION	BY	CHK APP.
UNIVERSITY OF CALIFORNIA <b>Los Alamos</b> Los Alamos National Laboratory Los Alamos, New Mexico 87545					
FACILITIES ENGINEERING DIVISION					
BLDG. Q-6			TA-14		
SUBMITTED BY <i>E. Traylor</i>		RECOMMENDED BY <i>Donna Ross</i>		APPROVED BY <i>Carl E. ...</i>	
DRAWN BY <i>Humberto HN</i>		DATE 8-30-83		SHEET NO. 1 OF 1	
				DRAWING NO. ENG-R 2693	

REC'D ... LOGGED TO VAULT 11-20-83

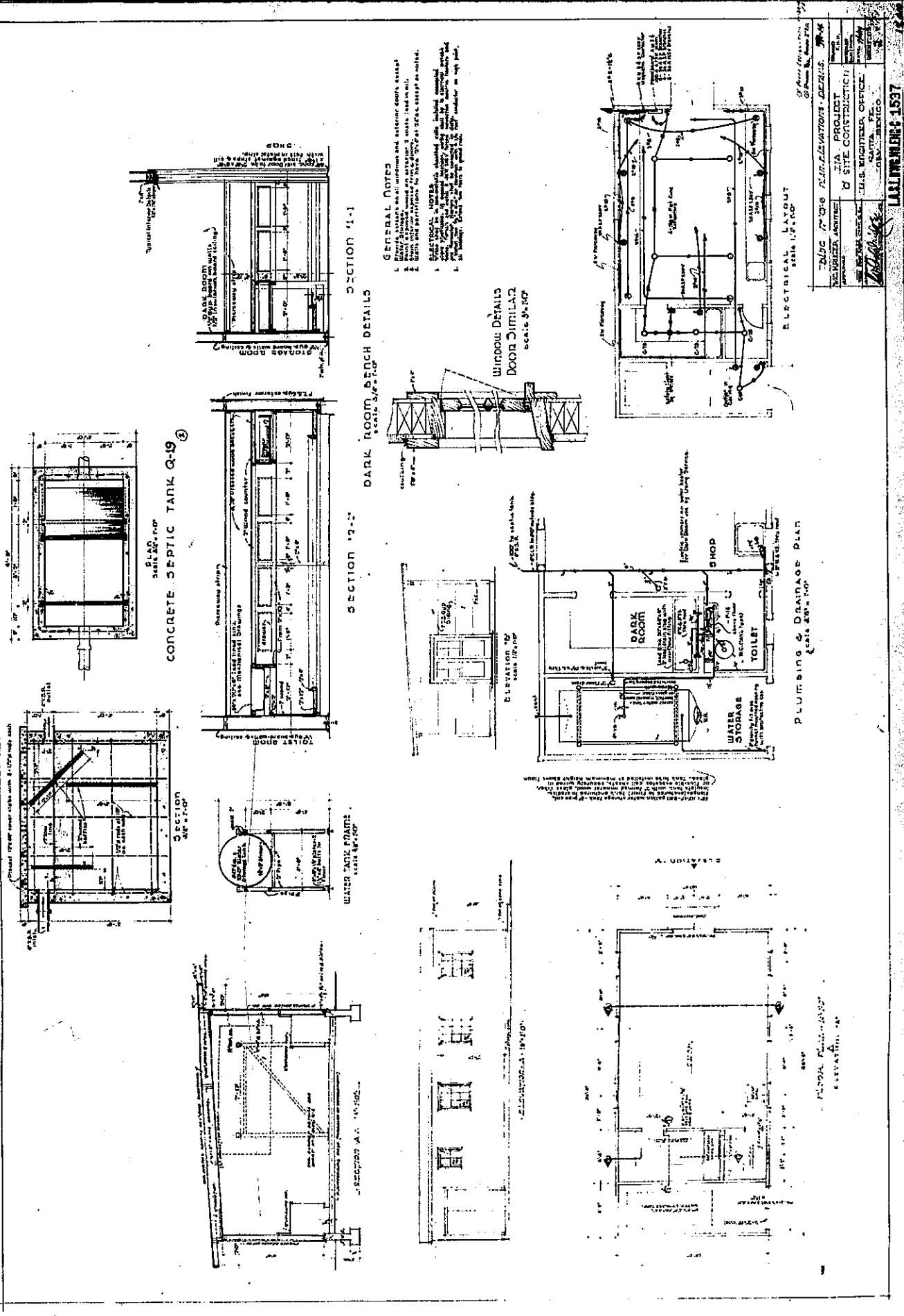

**GENERAL NOTES**

1. All dimensions are in feet and inches unless otherwise noted.
2. All materials are to be of standard quality unless otherwise noted.
3. All work is to be in accordance with the specifications and standards of the U.S. Army Corps of Engineers.
4. All work is to be in accordance with the standards of the U.S. Army Corps of Engineers.
5. All work is to be in accordance with the standards of the U.S. Army Corps of Engineers.

U.S. ARMY CORPS OF ENGINEERS	
WASH. D.C. 20315	
PROJECT NO.	DAAG 10-61-001
PROJECT NAME	PLUMBING & ELECTRICAL DETAILS
DATE	1961
DESIGNED BY	U.S. ENGINEER OFFICE
CHECKED BY	U.S. ENGINEER OFFICE
SCALE	AS SHOWN

PLUMBING & ELECTRICAL DETAILS

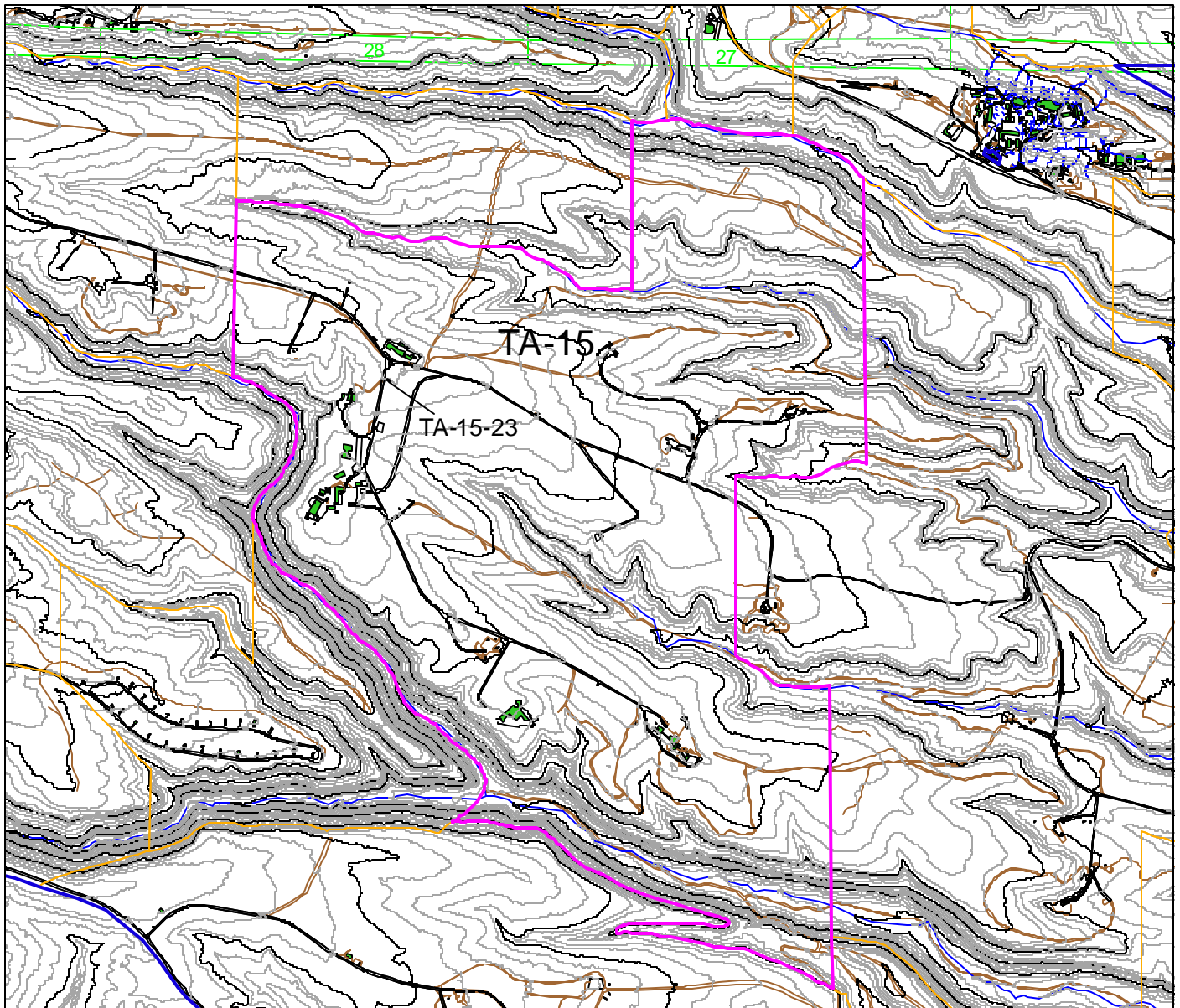

Frejoles Quad

# Los Alamos National Laboratory

Cultural Resources Management Team  
RRES-ECO Ecology Group

1:24000

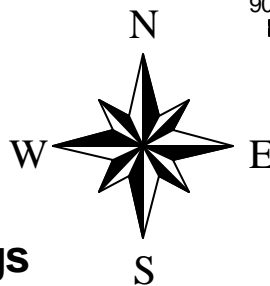
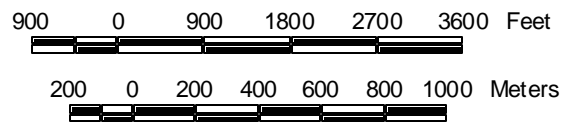

## Manhattan Project Buildings

### TA-15

- Manhattan Project Buildings
- Los Alamos National Laboratory
- Tech Area 15
- Tech Areas
- 20 Foot Contours
- 100 Foot Contours
- Drainage
- Township, Section, Range
- USGS 7.5 Minute Quad
- Roads
- Road/dirt
- Park/pave
- Park/dirt
- Buildings/Structures

Map 15

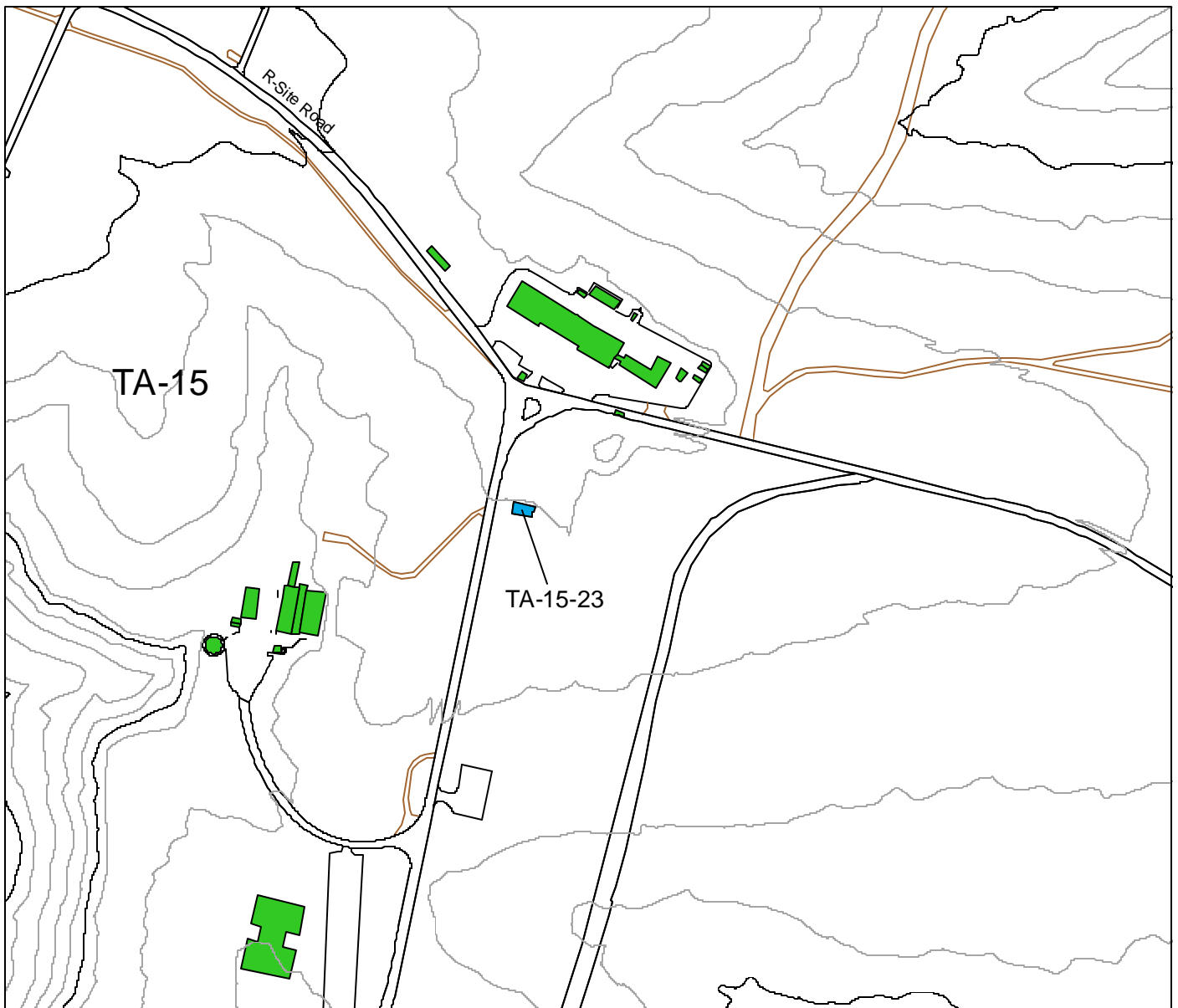

**Los Alamos**  
**National Laboratory**  
*Cultural Resources Management Team*  
*RRES-ECO Ecology Group*

1:4000

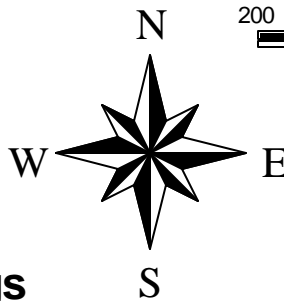
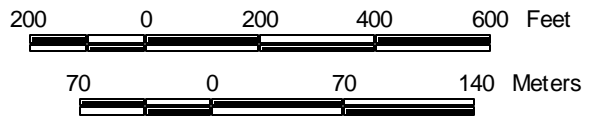

**Manhattan Project Buildings**

**TA-15**  
**Closeup**

- Manhattan Project Buildings
- Los Alamos National Laboratory
- Tech Area 15
- Tech Areas
- 20 Foot Contours
- 100 Foot Contours
- Drainage
- Township, Section, Range
- USGS 7.5 Minute Quad
- Roads
- Roaddirt
- Parkpave
- Parkdirt
- Buildings/Structures



### TA-15-23

**Original Function:** Initiator Laboratory

**Current Function:** Storage Building

**Historical Significance:** Initiator Research (while at TA-20); later, “GMX Manor” Control Building, Chemical Laboratory, and Assembly Area (while at TA-15).

**Date Constructed:** 1945

**Associated Theme:** Initiator Research and Explosives Testing

**Eligible?:** Yes – “A” (for its role at TA-15)

### **Description:**

TA-15-23 is a wood frame structure (657 ft<sup>2</sup> in size) that has a slanted asphalt roof. There are five, three-over-three sash windows located along the south elevation of the building, which also has a set of wooden double doors. Three additional sash windows are located on the north elevation of TA-15-23. These windows have an eight-over-eight light pattern. Steps and a personnel door are located on the west elevation of the building.

TA-15-23 (formerly TA-20-1) was built in 1945 during the Manhattan Project for use as a laboratory building at TA-20 (Sandia Site). TA-20, situated in Sandia Canyon, was abandoned in the late 1940s so that East Jemez Road could be built. TA-20 had been used to test initiators—devices used to add neutrons to nuclear explosions. In 1948, building TA-20-1 was relocated to R Site and renumbered TA-15-23. Various alterations were made to the building in 1949, including the relocation of the lavatory, the removal of partitions, and the removal of an exterior door along the south elevation. A personnel door leading to a new deck and steps was also added at that time. In 1951, the building was moved to its current location in TA-15. The original crane and hoist were both removed in 1951, and in 1957, a restroom was added.

While at TA-15, building TA-15-23 received the designation “GMX Manor” and the building was used in a variety of capacities supporting early Cold War high explosives testing activities: as a firing site control building, as a chemistry laboratory, as an assembly building for the non-explosives components of high explosives experiments, and as a main shop building. As a moved building, its ultimate significance is linked to its historical role at TA-15.



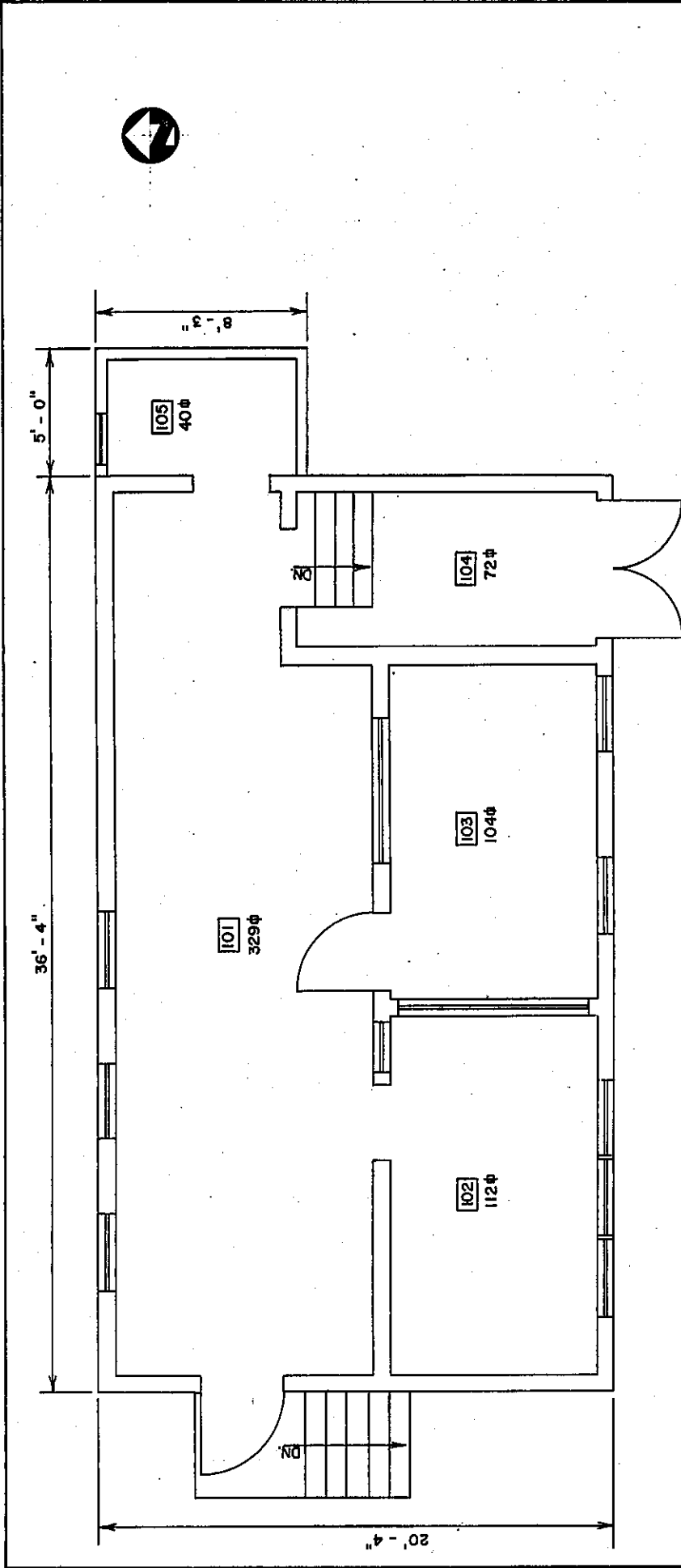

REV. 2	DATE 8-31-83	REVISION REDRAWN TO STATUS OF	8-31-83	BY HAN	DATE 8-31-83
UNIVERSITY OF CALIFORNIA			Los Alamos National Laboratory Los Alamos, New Mexico 87545		
Los Alamos			FACILITIES ENGINEERING DIVISION		
LABORATORY BLDG.			SEC. CLASSIFICATION		
FLOOR PLAN			CLASS. 4		
BLDG. R-23			REVISOR <i>[Signature]</i>		
SUBMITTED BY Kennedy			DATE TA-15		
DRAWN BY Kennedy			APPROVED <i>[Signature]</i>		
CHECKED <i>[Signature]</i>			DATE 8-31-83		
RECOMMENDED <i>[Signature]</i>			SHEET NO. 1 OF 1		
DATE 8-31-83			DRAWING NO. ENG-R2712		

MF

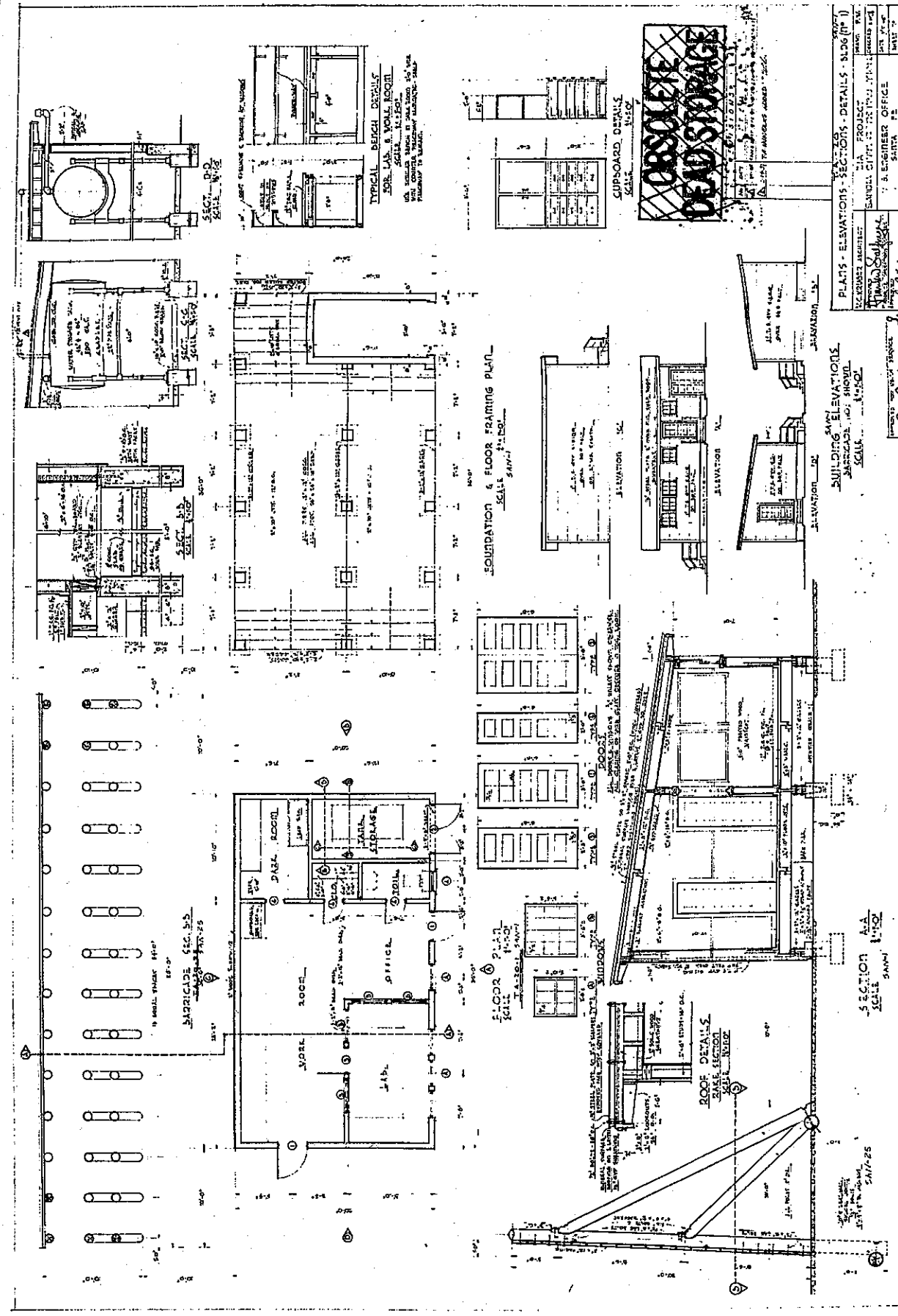

PLANS - ELEVATIONS - SECTIONS - DETAILS - SLOPE (1/1)

PROJECT	NO. 1
CLIENT	MR. J. J. J.
DATE	1950
SCALE	1/4" = 1'-0"
ENGINEER	R. F. BAKER
OFFICE	1155 N. GARDEN ST. LOS ANGELES, CALIF.
STATE	CALIF.
CITY	LOS ANGELES

BUILDING ELEVATIONS  
 SCALE: 1/4" = 1'-0"

SECTION 1-1  
 SCALE: 1/4" = 1'-0"

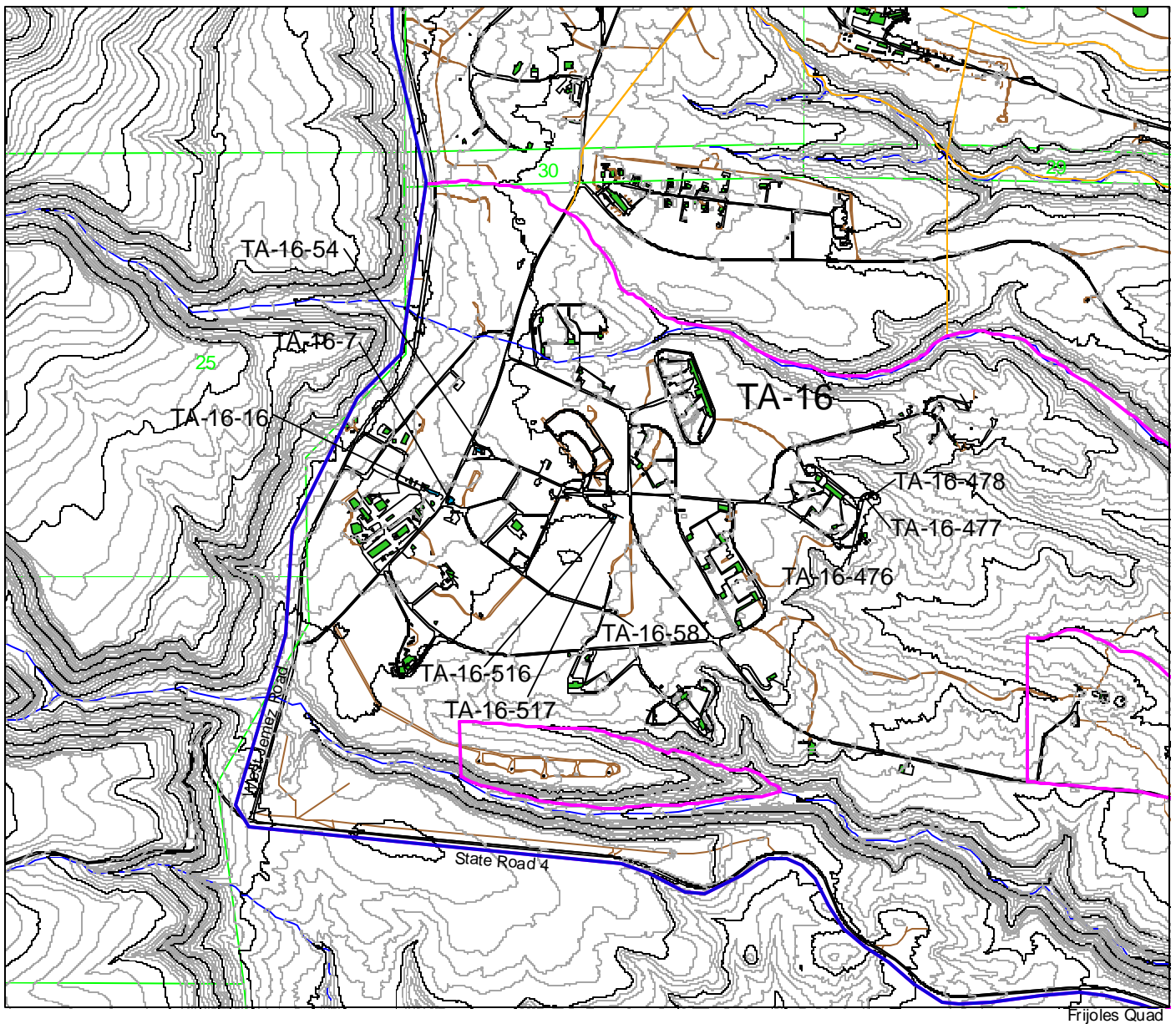

Frijoles Quad

# Los Alamos National Laboratory

Cultural Resources Management Team  
RRES-ECO Ecology Group

1:24000

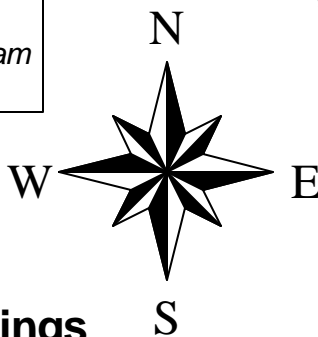
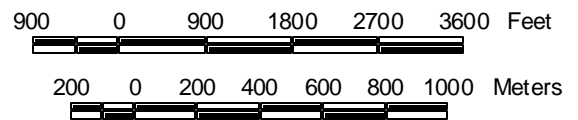

## Manhattan Project Buildings

## TA-16

- Manhattan Project Buildings
- Los Alamos National Laboratory
- Tech Areas 3, 8, 11, & 16
- Tech Areas
- 20 Foot Contours
- 100 Foot Contours
- Drainage
- Township, Section, Range
- USGA 7.5 Minute Quad
- Roads
- Road dirt
- Park pave
- Park dirt
- Buildings/Structures

Map 17

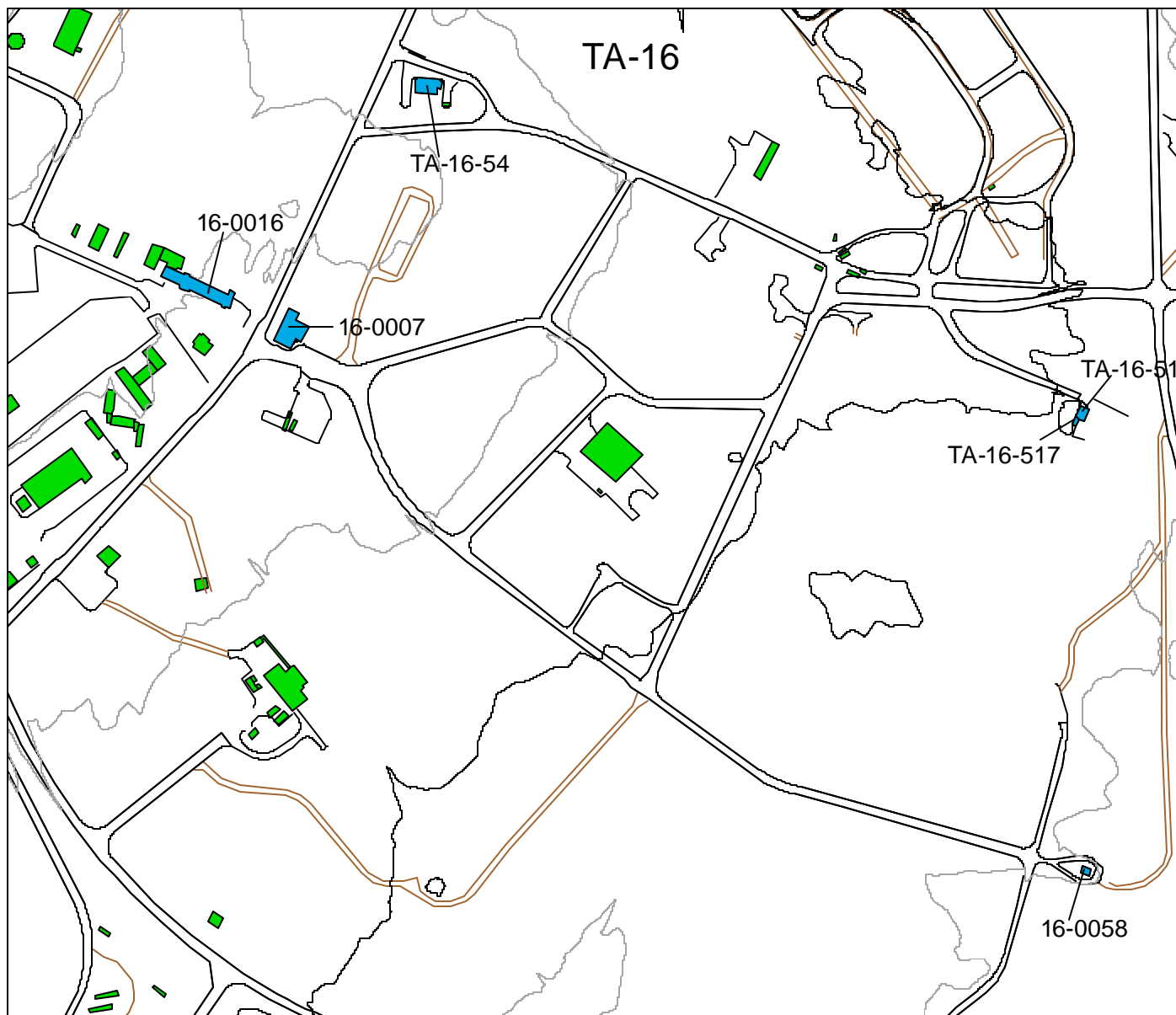

Frijoles Quad

# Los Alamos National Laboratory

Cultural Resources Management Team  
RRES-ECO Ecology Group

1:5000

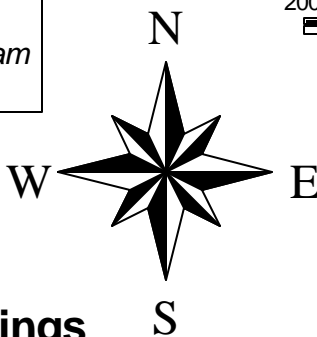
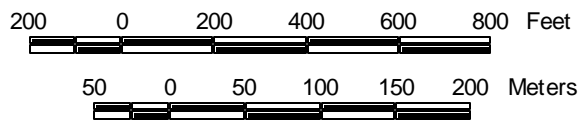

## Manhattan Project Buildings

## Western TA-16 Closeup

- Manhattan Project Buildings
- Los Alamos National Laboratory
- Tech Area 16
- Tech Areas
- 20 Foot Contours
- 100 Foot Contours
- Drainage
- Township, Section, Range
- USGS 7.5 Minute Quad
- Roads
- Roaddirt
- Parkpave
- Parkdirt
- Buildings/Structures

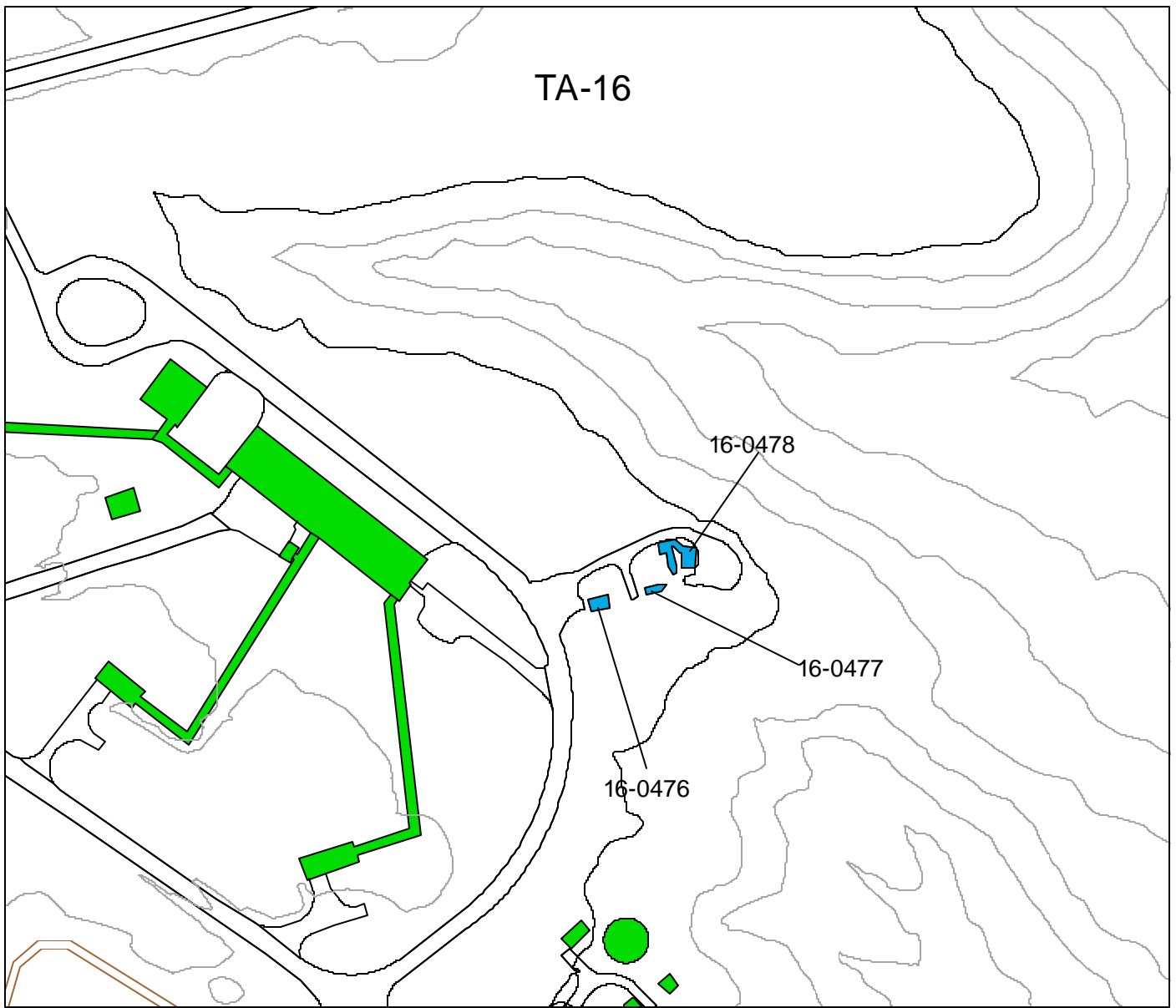

Frijoles Quad

# Los Alamos National Laboratory

Cultural Resources Management Team  
RRES-ECO Ecology Group

1:2500

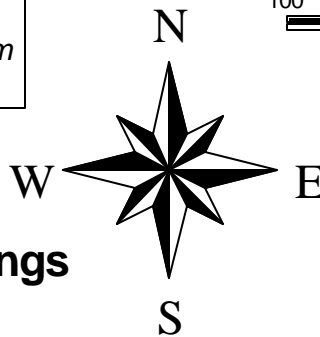
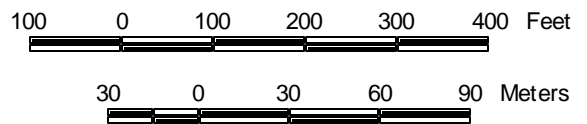

## Manhattan Project Buildings

## Eastern TA-16 Closeup

- Manhattan Project Buildings
- Los Alamos National Laboratory
- Tech Area 16
- Tech Areas
- 20 Foot Contours
- 100 Foot Contours
- Drainage
- Township, Section, Range
- USGS 7.5 Minute Quad
- Roads
- Road/dirt
- Park/pave
- Park/dirt
- Buildings/Structures

Map 19



### TA-16-7

**Original Function:** Steam Plant/Machine Shop      **Date Constructed:** 1944  
**Current Function:** Storage (not in use)      **Associated Theme:** High Explosives  
**Historical Significance:** Support building for TA-16 (S Site) activities.      **Eligible?:** No (extensive renovation)

#### **Description:**

Building TA-16-7 was originally constructed as a steam plant that measured 90 ft wide by 40 ft deep and contained an open two-story boiler room, a one-story generator room, and a shop area. An oil storage shed and coal storage bin were constructed on the north side of the building. The building was constructed with reinforced concrete footings, 6 in. concrete floor slab, 2 in. by 6 in. wood-frame walls with triple sealed gypsum siding exterior on the exterior and one-half in. gypsum board on the interior. A medium pitched wood truss gable roof with four ridge ventilators covered the boiler room while the remaining areas were covered by a low-pitched gable roof. Oversized double wood doors, on the north side, provided access into the boiler room. The room was also equipped with wood-frame double-hung windows. The generator room was equipped with wood paneled double doors, wood-frame hopper-style windows, two roof ventilators, and wood wall louvers. The generator room was also equipped with an I-shaped fuel oil service floor trench. The oil storage shed contained a 4000-gallon oil storage tank. The concrete coal storage bin was approximately 6 ft tall, equipped with a hinged 6 ft by 8 ft cover, and bermed with compacted earth on three sides. The shop area was constructed with wood fixed frame windows to provide visual access into the adjacent generator room.

In 1945, a 54 ft by 40 ft boiler room addition was constructed on the east side of the original boiler room. The open two-story boiler room was constructed with concrete footings and 6 in.



slab floor, wood-frame walls, and wood roof trusses to match the roofline of the original boiler room. A one-story shop with shed roof was constructed on the east end of the new boiler room. At this time, a one-story addition was also constructed on the west side of the original shop area. A welding booth was included in the new machine shop area. Construction was similar to the existing building in that it had concrete footings and floor slab, wood-frame walls, and a low-pitched gable roof matching the original roofline. Wood doors and double-hung windows were also installed.

The original boiler room underwent a second expansion in 1948 with the addition of a 32 ft by 64 ft boiler room on the north side. The new two-story boiler room contained three boiler pads with a fourth pad for future expansion. The second addition was constructed with concrete footings, 6 in. concrete slab floor and 30 in. concrete stem wall, 2 in. by 6 in. wood studs walls sheathed with asphalt shingles, and a wood truss shed roof.

In 1950, the machine shop was enlarged with a 41 ft 6 in. by 28 ft addition constructed on the south side. The addition contained the expanded shop area and two offices. The expansion was constructed with concrete footings and slab floor, 2 in. by 10 in. stud walls, 4 in. diameter pipe columns, and a low-pitched shed roof with a full-width clerestory. The original shop roof was modified to allow for a higher clearance height and the installation of a one-ton hoist and trolley. Double doors on the south side accessed a concrete dock and ramp. The interior walls of the building were sheathed with both horizontal 1 in. by 4 in. and 1 in. by 12 in. wood planks.

Demolition of the boiler rooms and east end shop area occurred in 1953. As of 1953, the generator room and adjacent shop area was all that remained of the original building construction. The machine shop and expansion continued to be used. In 1969, the existing concrete dock was enlarged and a new ramp installed. One office was converted into a tool crib and the original welding room was converted into a spare parts crib. Wire mesh security doors enclosed the spare parts crib.

The building was originally constructed as a steam plant for the area. Once the boilers and supporting equipment were removed, the remaining shop areas were converted for the maintenance and repair of high explosives equipment within TA-16. This function has since been transferred to building TA-16-54. The building is not in use.







### TA-16-16

**Original Function:** Cafeteria  
**Current Function:** Office Building  
**Historical Significance:** Support building for TA-16 (S Site) activities.

**Date Constructed:** 1945  
**Associated Theme:** High Explosives/Admin. Support  
**Eligible?:** No (extensive renovation)

#### **Description:**

Building TA-16-16 is one story in plan and measures 30 ft 4 in. by 193 ft 2 in. A 7 ft 10 in. deep covered dock area is located near the northwest end of the building. The building was originally constructed over a crawl space with concrete perimeter foundation with interior posts and piers supporting wooden floor joists. The building was constructed with wood stud walls and a medium-pitched gable roof. The main roof continued past the eave line to shelter the 15 in. high concrete dock area on the northwest side.

Two walk-in refrigerators, each with their own compressor rooms, were located on the west side of the building. Both refrigerators could be accessed from a small hall off of the kitchen area, which also exited to the outside. The south-side refrigerator had a concrete floor and wood tongue and groove walls and ceiling. The north-side refrigerator floor was wood, and plywood covered the walls and ceiling. The north end of the building was devoted to the kitchen and serving line areas. The remaining space was allocated to customer seating. A partially below grade mechanical room, with shed roof, was located on the southeast corner of the building and accessed by a pair of doors.

The primary cafeteria entrance was located near the southwest corner of the building. Due to the change in grade from the north to the south ends, this entrance was raised approximately 5 ft

above grade and accessed by exterior stairs. A single door was also located at the north end of the building and served as a second exit from the kitchen area.

The building was renovated into office space in the early 1990s. The original shingle roof was removed and a standing seam metal roof applied. The asbestos wall shingles were also removed and the exterior walls covered with an exterior insulation finish system. New double-hung and sliding aluminum windows were installed down the length of the building on both sides. The walls on the interior were finished with drywall and painted, and acoustical tile was applied to the ceilings. The floors have been carpeted.









TA-16-54

**Original Function:** Grinding Building  
**Current Function:** Plastics/Shop Building  
**Historical Significance:** Process building for early high explosives research and development.

**Date Constructed:** 1946  
**Associated Theme:** High Explosives  
**Eligible?:** Yes – “A”

**Description:**

TA-16-54 was built in 1946 and was used for grinding operations. It is currently used as a plastics building and machine shop. The 3,790 ft<sup>2</sup> building is two stories high with a covered loading dock on the north side and a small basement mechanical room with outside access on the southeast corner. The first story is concrete post and beam with concrete (CMU) block infill. The second story is wood and metal frame with asbestos-containing corrugated siding. The roof is flat with a built up roof subsequently covered with a single ply roofing material. There is a roof overhang of about 18 in. on all sides of the building. The overall structure has been re-stuccoed and painted several times over the years. The windows are metal commercial-grade windows with divided lights. The entry door is wood plank resembling original construction material. The building is currently in use as a shops building similar to its original use and activity.

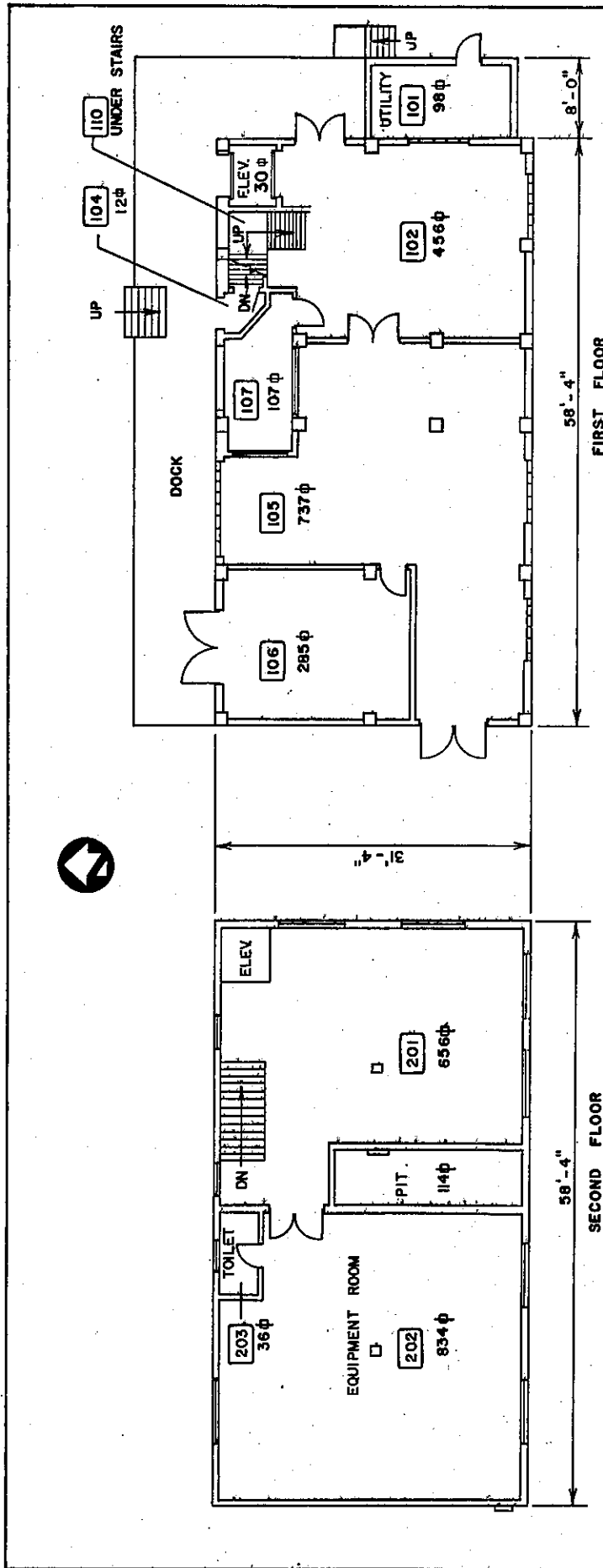

FIRST FLOOR

SECOND FLOOR

REV. DATE	3 9-7-83	REDRAWN & REVISED TO STATUS OF	9-7-83	HSN	BY	CDL/APP
UNIVERSITY OF CALIFORNIA						
Los Alamos National Laboratory Los Alamos, New Mexico 87545						
FACILITIES ENGINEERING DIVISION						
BLDG. 54		GRINDING BUILDING		SEC. CLASSIFICATION		
FIRST & SECOND FLOOR PLAN		TA-16		CLASS. K		
SUBMITTED		RECOMMENDED		REVIEWED		
DATE 10-1-83		DATE 10-1-83		DATE 10-1-83		
DRAWN MARSH HSN		DATE 9-7-83		DRAWING NO. ENG-R2749		
CHECKED HAN		SHEET NO. 1		OF 1		

FT <sup>2</sup>	1725
FIRST FLOOR	1640
SECOND FLOOR	3365
TOTAL	3365

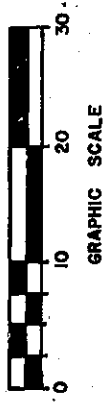

(1" = 10'-0")

ALL D... LOGGED... TO VANT... 83





### TA-16-58

**Original Function:** Magazine  
**Current Function:** Vacant  
**Historical Significance:** Explosives process storage building in support of TA-16 (S Site) activities.

**Date Constructed:** 1944  
**Associated Theme:** High Explosives  
**Eligible?:** Yes – “A”

#### **Description:**

Building TA-16-58 is a one-story, single-room structure measuring 13 ft by 23 ft with an interior floor area of 210 ft<sup>2</sup>. The structure was constructed with a reinforced concrete foundation, floor, and walls. The concrete walls were left exposed to approximately three-quarter height of the wall then covered with asbestos shingles over wood framing. A medium-pitched wood-framed gable roof with exposed rafter ends and rolled roofing cover the structure. Both gable ends contain metal louvers with screen transoms for ventilation. A lightning rod is located on the roof and grounded.

An earthen berm to three-quarter height of the walls surrounds the magazine on the south, west, and north sides. The east side was left exposed and contains double steel doors, the only access into the building. Square wooden posts and wood plank wing walls extend out from the face of the east wall and are used as retaining walls for the earthen berm surrounding the building.







TA-16-476 (former TA-13-2)

<b>Original Function:</b>	Laboratory/Testing Building	<b>Date Constructed:</b>	1944
<b>Current Function:</b>	Control Room	<b>Associated Theme:</b>	High Explosives
<b>Historical Significance:</b>	Supported flash X-ray studies of implosions leading to the development of the implosion device.	<b>Eligible?:</b>	Yes – “A” and “C”

**Description:**

Building TA-16-476 is a single-story structure containing 126 ft<sup>2</sup>. The load-bearing structure was constructed with a reinforced concrete foundation, 18 in. thick reinforced concrete walls, flat roof, and two forward protruding wing-walls on the west side. The single entrance into the control room is through a wood door located on the west wall. The remaining three walls are heavily bermed with compacted earth. The flat roof is also covered with earth but to a lesser depth. The interior of the control room contains a single 9 ft by 14 ft room. Interior ventilation is provided through exterior ductwork located adjacent to the entry door.

The building was originally constructed as a laboratory to support flash X-ray studies during the Manhattan Project. This building was later used for high explosives machining studies. The building is now vacant.

NO.	DATE	REVISIONS	BY	CHKD	ENGR
1	8-30-65	REVISED TO STATUS OF 8-19-65 DRK	DRK	B	BERG

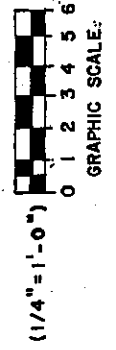
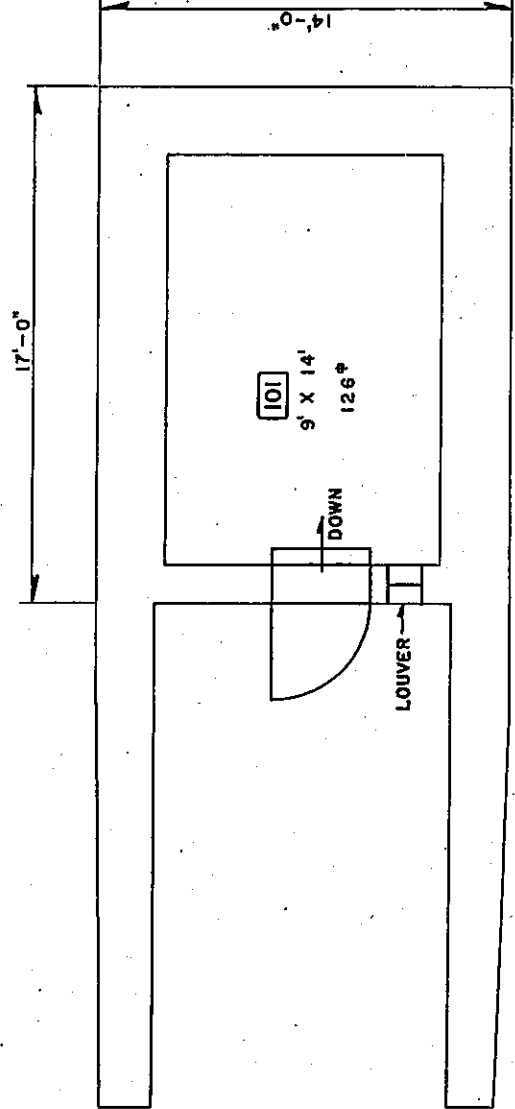

TOTAL SQ. FT. 126

REV.	DATE	REVISION	BY	CHKD.	ENGR.
2	8-30-65	REVISED TO STATUS OF 8-30-63	DRK	B	BERG
UNIVERSITY OF CALIFORNIA					
<b>Los Alamos</b>					
Los Alamos National Laboratory Los Alamos, New Mexico 87545					
FACILITIES ENGINEERING DIVISION					
BLDG. 475			TA-16		
SUBMITTED		RECOMMENDED		DATE	
L. Taylor		D. R. ...		9-29-65	
DRAWN		DATE		SHEET NO.	
H. H. ...		6-17-63		1 OF 1	
CHECKED		DATE		DRAWN BY	
H. H. ...		6-17-63		ENG-R2863	

RECD/LOGGED/FILED TO VAULT/...

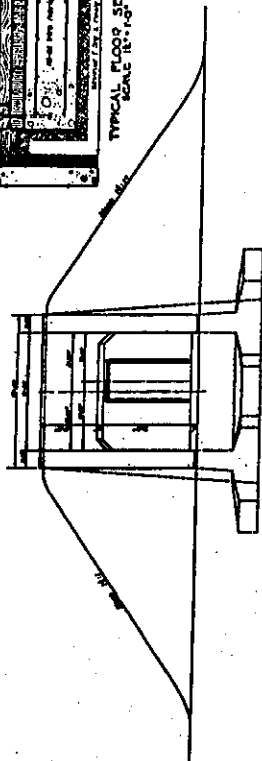
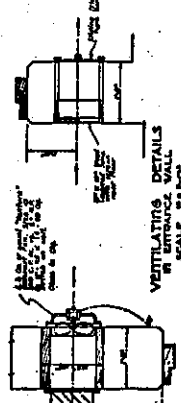
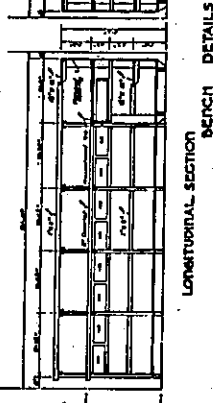
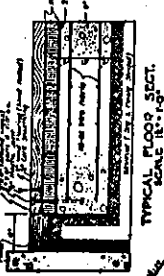
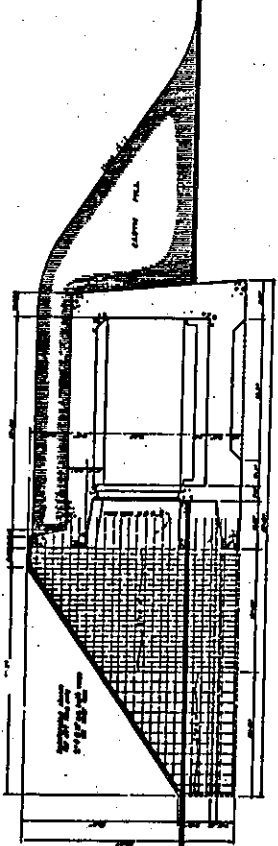
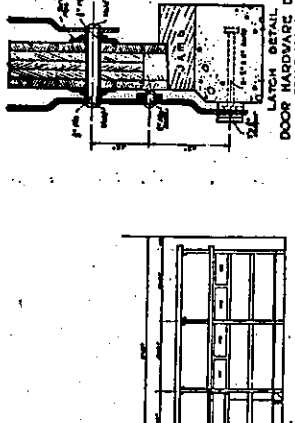
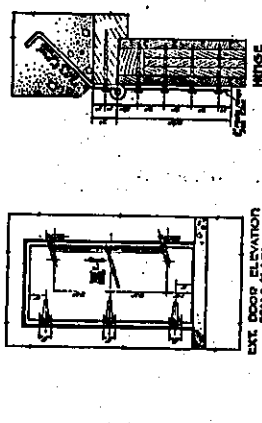
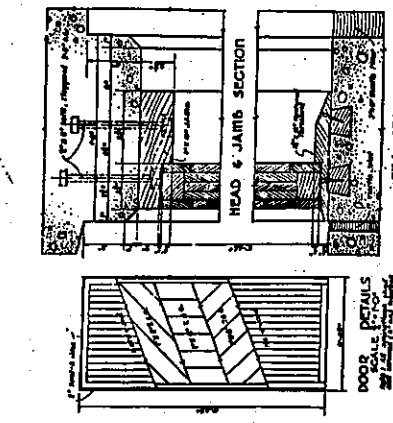
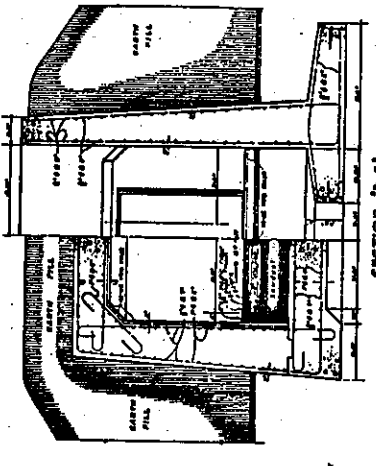
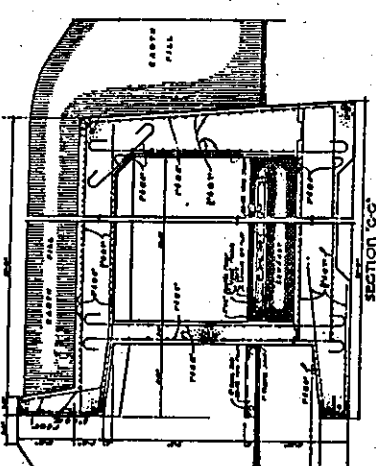
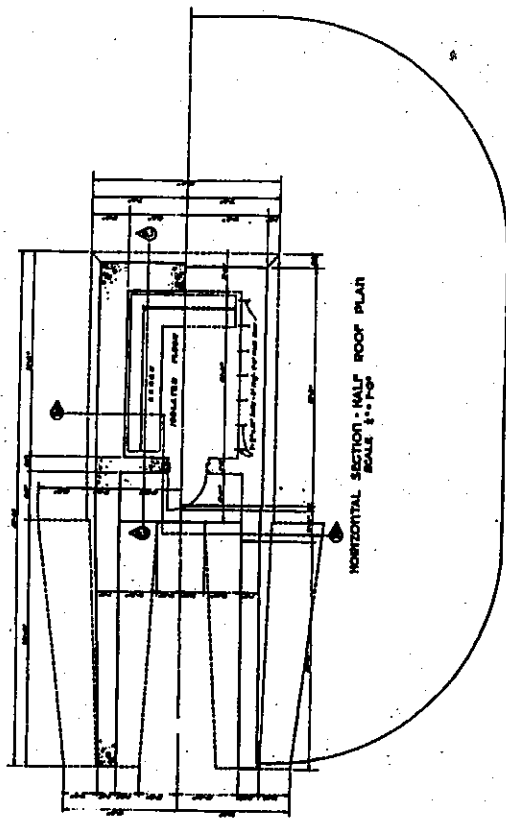

GENERAL NOTES  
 1. ALL WORK SHALL BE IN ACCORDANCE WITH THE LATEST EDITIONS OF THE U.S. ARCHITECTURAL PRACTICE CODE AND THE U.S. MECHANICAL AND ELECTRICAL CODES.  
 2. ALL MATERIALS SHALL BE OF THE BEST QUALITY AND SHALL BE APPROVED BY THE ARCHITECT BEFORE ORDERING.  
 3. ALL WORK SHALL BE DONE IN ACCORDANCE WITH THE MANUFACTURER'S INSTRUCTIONS.

BLDG. NO. P-2	PLANS - ELEVATIONS - SECTIONS - DETAILS
PROJECT NO.	21A PROJECT
DATE	P-RITE CONSTRUCTION CO.
BY	U.S. ENGINEER OFFICE
CHECKED BY	U.S. ENGINEER OFFICE
DATE	APR 11, 1943
SCALE	AS SHOWN

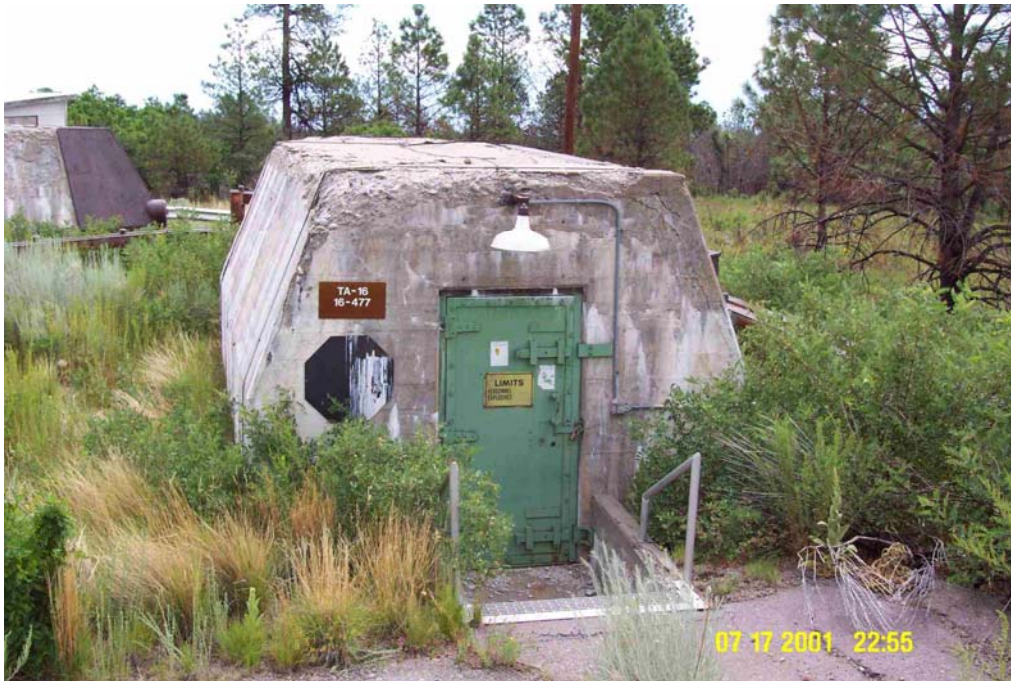

TA-16-477 (former TA-13-3)

<b>Original Function:</b>	Laboratory/Testing Building	<b>Date Constructed:</b>	1944
<b>Current Function:</b>	Rest House/Storage	<b>Associated Theme:</b>	High Explosives
<b>Historical Significance:</b>	Supported flash X-ray studies of implosions leading to the development of the implosion device.	<b>Eligible?:</b>	Yes – “A” and “C”

**Description:**

Building TA-16-477 is torpedo-like in shape and measures 12 ft by 35 ft 6 in. The building was constructed of heavily reinforced concrete foundation and floor slab, tapered walls, and a flat roof. The thickness of the walls allows for only 176 ft<sup>2</sup> of floor space within the building.

The entire structure is located approximately two ft below grade. The single access point is through a reinforced steel door with bolt locks and heavy strap hinges on the west side. The tapered end of the building, located on the east side, was designed to shoot X-rays through a tube. The tapered end, covered with steel plates, was also designed to deflect shrapnel should an explosion occur.

The building was originally constructed as a laboratory building to support flash X-ray studies during the Manhattan Project. This building was later used for high explosives machining studies. The building is currently vacant.

NO.	DATE	REVISIONS	BY	CHKD	GRP	ENG.
				LDR.		D.O.
1	8-30-65	REVISED TO STATUS OF 8-19-65 DRK	DRK	BSEK		

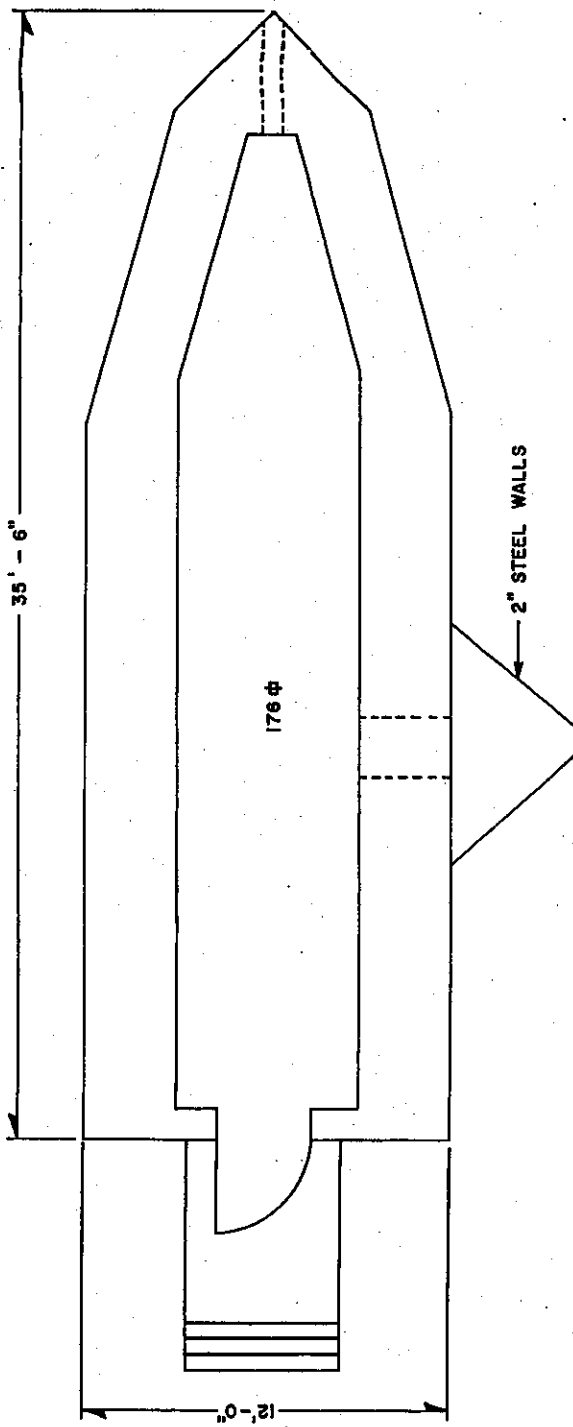

REV.	DATE	REVISED TO STATUS OF	REVISION	BY	CHKD	GRP	ENG.
2	9-1-63	REVISED TO STATUS OF 9-1-63					
UNIVERSITY OF CALIFORNIA							
<b>Los Alamos</b>							
Los Alamos National Laboratory Los Alamos, New Mexico 87545							
FACILITIES ENGINEERING DIVISION							
BLDG. 477				TA-16			
DESIGN		CHECKED		RECOMMENDED		REC. CLASSIFICATION	
BREMER		Humbler		Dunbar		CLASS. 4	
DATE 6-17-63		DATE 6-17-63		DATE 9-27-65		REVISIONS	
SHEET NO. 1		SHEET NO. 1		SHEET NO. 1		DATE 9-27-65	
OF 1		OF 1		OF 1		ENG-82884	

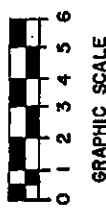

TOTAL SQ. FT. 176

REC'D WITH LOGGED TO VAULT

REC'D LOGGED TO VAULT 11-22-63

THE UNIVERSITY OF CALIFORNIA





TA-16-478 (former TA-13-4)

**Original Function:** Laboratory and Machine Test Building

**Current Function:** Vacant

**Historical Significance:** Supported flash X-ray studies of implosions leading to the development of the implosion device.

**Date Constructed:** 1944

**Associated Theme:** Implosion

**Eligible?:** Yes – “A” and “C”

**Description:**

TA-16-478 was constructed as two separate buildings connected by an enclosed corridor. Room A, like building TA-16-477, is torpedo-like in shape and measures 12 ft by 35 ft 6 in. The building was constructed of heavily reinforced concrete foundation and floor slab, tapered walls, and a flat roof. The thickness of the walls allows for only 178 ft<sup>2</sup> of floor space within the building. The only entry into Room A is from the north side within the corridor structure. The pointed end of the building is also covered with metal plates to protect the building from explosive testing. Room C is located adjacent to the north end of Room A. Room C, 99 ft<sup>2</sup> in size, is a wood-frame structure with asbestos shingle siding and a flat roof. Room C housed a lathe and is accessed from the shared corridor through a pair of wooden doors. The main corridor is accessed by way of a pair of exterior wooden doors with four lights each. These doors are located on the north side of the building. Room B contains 252 ft<sup>2</sup> and measures 2 ft 9 in. by 17 ft 2 in. The north, west, and south walls of Room B were constructed with a reinforced concrete foundation and floor slab, thick reinforced concrete walls, and a flat roof. The east wall is framed with 2 in. by 4 in. wood studs and covered with asbestos shingle siding. Both a concrete pad and sump pit are located to the south of Room B. A raised metal cable tray spans the length of Rooms C and A to the west. The cable tray housed signal, power, and electrical cables.



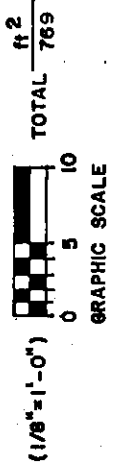
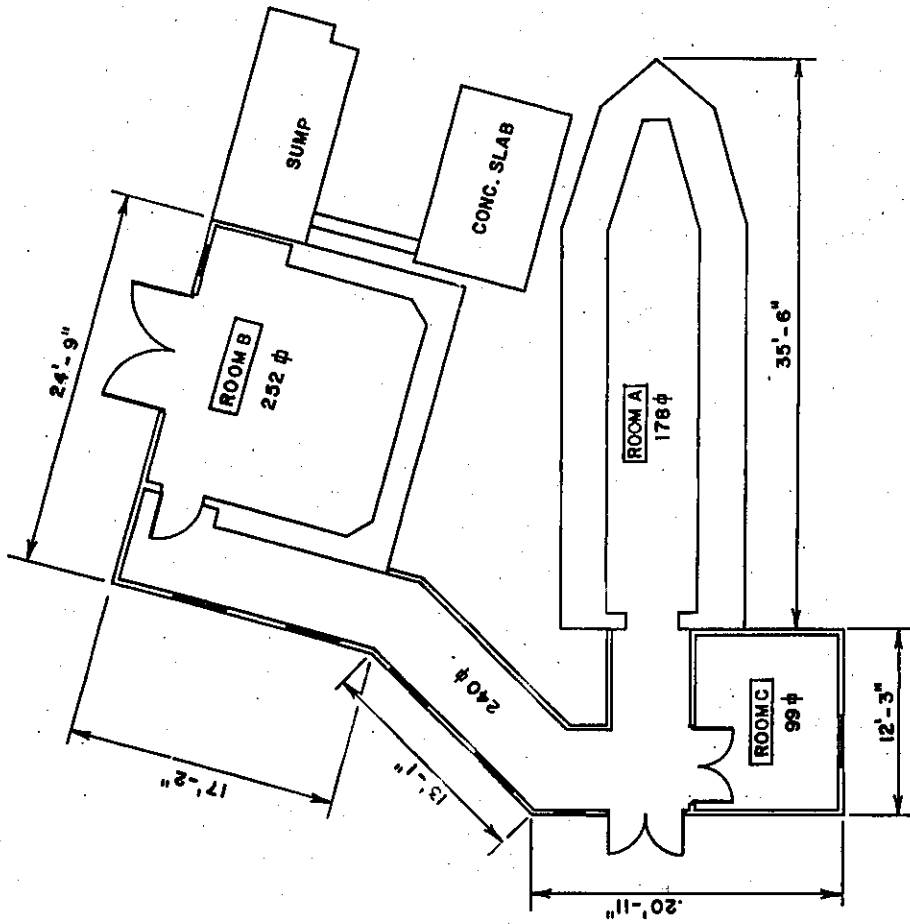

REV.	DATE	REVISION	BY	CHKD.
2	9-7-83	REDRAWN & REVISED TO STATUS OF 9-7-83	HAN	HAN
UNIVERSITY OF CALIFORNIA <b>Los Alamos</b> Los Alamos National Laboratory Los Alamos, New Mexico 87545				
FACILITIES ENGINEERING DIVISION				
BLDG. 478			REC. CLASSIFICATION	
FLOOR PLAN			CLASS.	4
RECORDED			REVISION	1
DATE			DATE	DATE
9-6-83			9-8-83	9-8-83
DRAWN			APPROVED	
MARSH HAN			Dan R. [Signature]	
CHECKED			SHEET NO.	
Thom [Signature]			1 of 1	
			ENG'R 2685	

REC'D LOGGED TO VAULT 11-12-83



TA-16-517

TA-16-516

TA-16-516 and TA-16-517

**Original Function:** Processing /Inspection

**Date Constructed:** 1944

**Current Function:** Vacant

**Associated Themes:** Implosion/Gun Device/Trinity Test

**Historical Significance:** Supported implosion, gun, and Trinity device assembly and shake tests.

**Eligible?:** Yes – “A”

**Description:**

TA-16-516 is a wood-frame building with a concrete foundation and a flat roof. The building has a 16-ft ceiling with an overhead hoist mounted on an I-beam track. TA-16-516 is fairly small, approximately 570 ft<sup>2</sup> in size. A “kettle” platform and scale pit were added in the early 1950s. TA-16-517 is located next to TA-16-516. Like its adjacent building, TA-16-517 is of wood-frame construction with a concrete foundation and a flat roof. TA-16-517 is much smaller than TA-16-516, with an approximate floor area of 318 ft<sup>2</sup>. An earthen barricade containing tie rods, cables, and log “deadmen” encloses the triangular-shaped building on two of three sides.

Building TA-16-517 was originally used as a processing/inspection building. It was later used as an equipment room for TA-16-516. The high explosives components for the “Trinity” device were assembled in TA-16-516 in the summer of 1945. Building TA-16-516 was later used for inert storage.

NO.	DATE	REVISIONS	BY	CHK'D OR D.C.	DATE
1	9-1-65	REVISED TO STATUS OF 8-19-65	JAS	SEP 13	

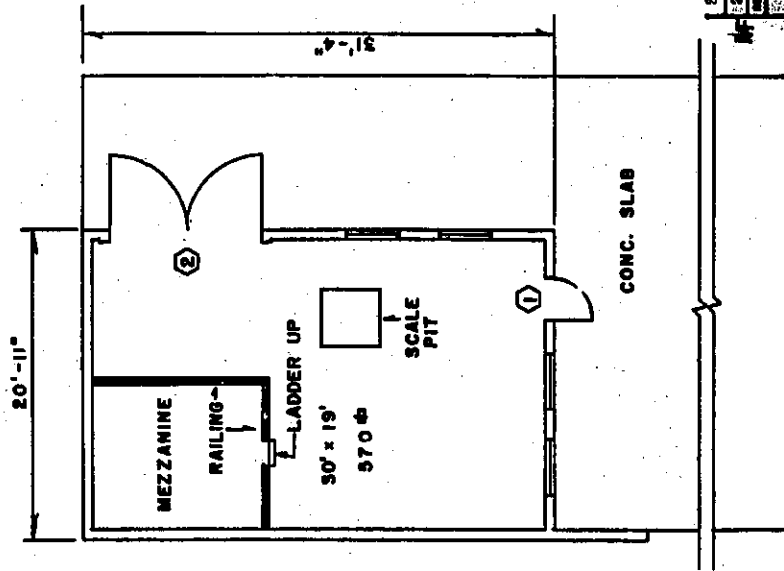

NO.	DATE	REVISIONS	BY	CHK'D OR D.C.	DATE
1	9-2-65	REVISED TO STATUS OF 9-2-65			
2	9-2-65	REVISED TO STATUS OF 9-2-65			

UNIVERSITY OF CALIFORNIA  
**Los Alamos** Los Alamos National Laboratory  
 Los Alamos, New Mexico 87545

**FACILITIES ENGINEERING DIVISION**

**FLOOR PLAN**

BLDG. 516 TA-8

GRAPHIC SCALE

REC'D LOGGED ✓ TO VAULT 11-2-65

TOTAL SQ. FT. 570

Building TA-16-516

LANL DWG. R 2887 (1964)

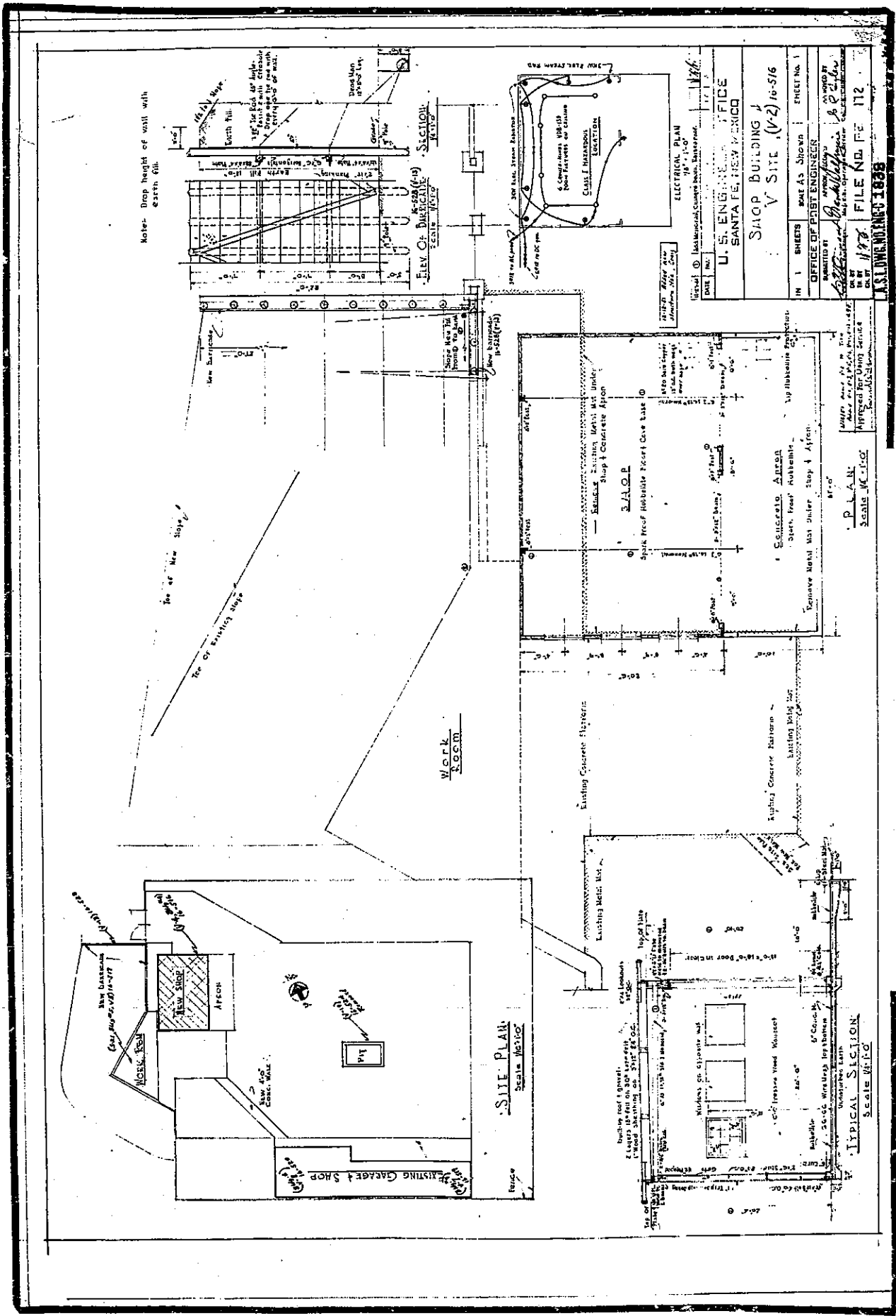

Note: Drop height of wall with earth fill.

FLY CH DAMASCUS SECTION  
SCALE 1/4" = 1'-0"

ELECTRICAL PLAN  
SCALE 1/4" = 1'-0"

U. S. ENGINEERING OFFICE SANTA FE, NEW MEXICO	
IN 1 SHEETS	WORK AS SHOWN SHEET NO. 1
OFFICE OF DISTRICT ENGINEER	
PROJECT NO. 16-516	
DRAWN BY: [Signature]	
CHECKED BY: [Signature]	
DATE: 1/27/44	
FILE NO. FE 112	

ALLOWANCE 1838

SITE PLAN  
SCALE 1/4" = 1'-0"

TYPICAL SECTION  
SCALE 1/4" = 1'-0"

Building TA-16-516

LANL DWG. C. 1838 (1944)

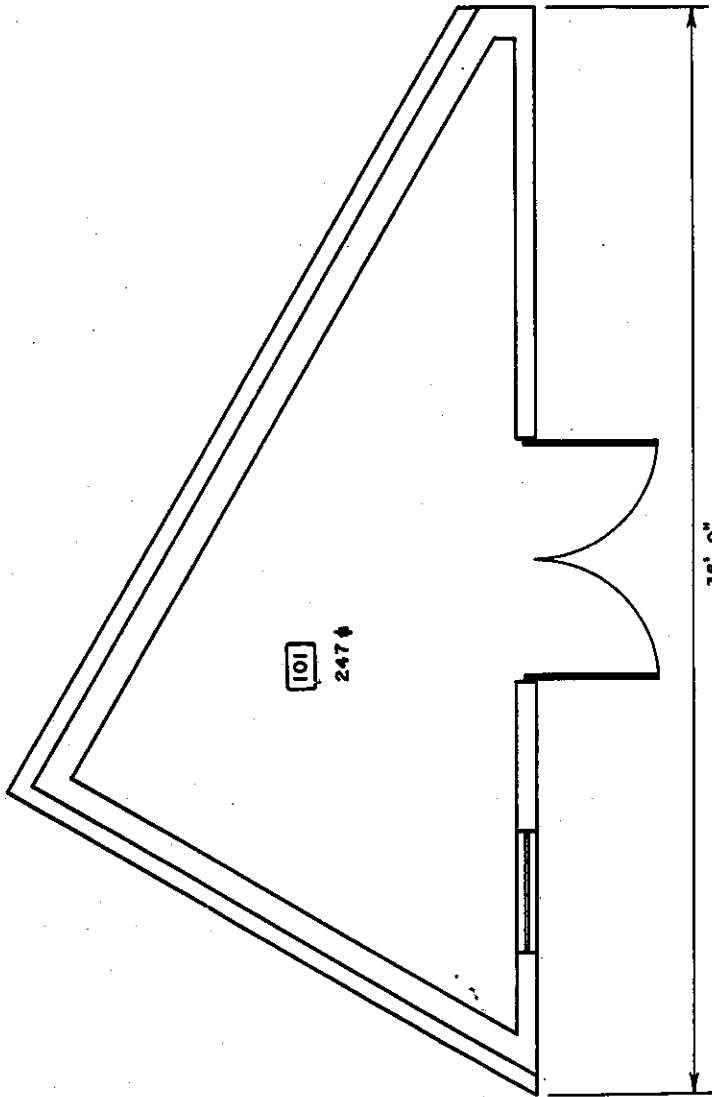

REV.	DATE	DESCRIPTION	BY	CHK'D
2	8-17-83	REDRAWN & REVISED TO STATUS OF 8-17-83		
UNIVERSITY OF CALIFORNIA				
<b>Los Alamos</b>				
Los Alamos National Laboratory Los Alamos, New Mexico 87565				
<b>FACILITIES ENGINEERING DIVISION</b>				
<b>FLOOR PLAN</b>				
BLDG. 517		TA-16		
DESIGNED BY	DRAWN BY	CHECKED BY	DATE	SCALE
10. Taylor	10. Taylor	10. Taylor	8-17-83	1/4" = 1'-0"
PROJECT NO. MARSH HON		SHEET NO. 1 OF 1		
CHECKED BY		DATE		
10. Taylor		8-17-83		
REC'D - LOGGED TO VAULT 11-1-83				



Building TA-16-517  
LANL DWG. R. 2888 (1983)

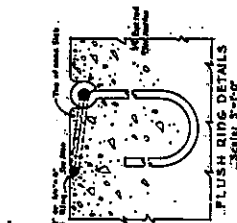
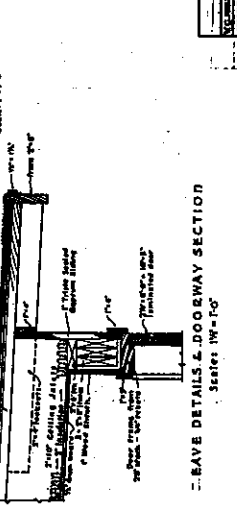
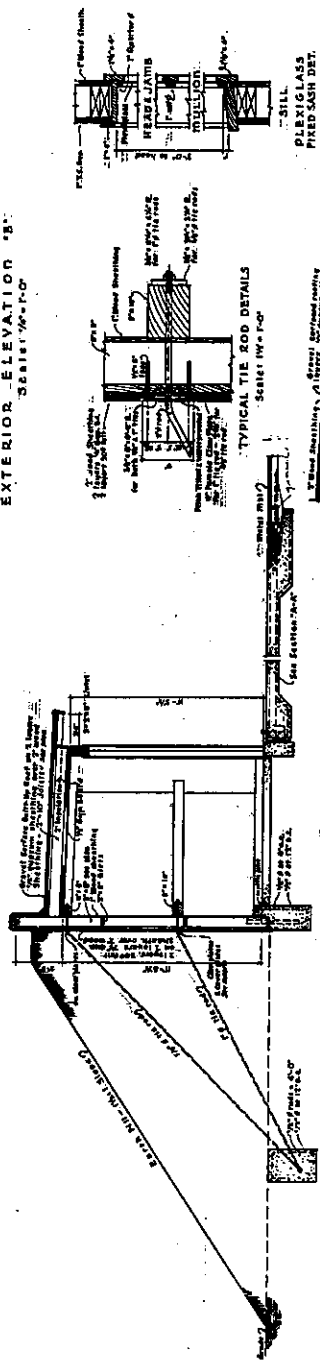
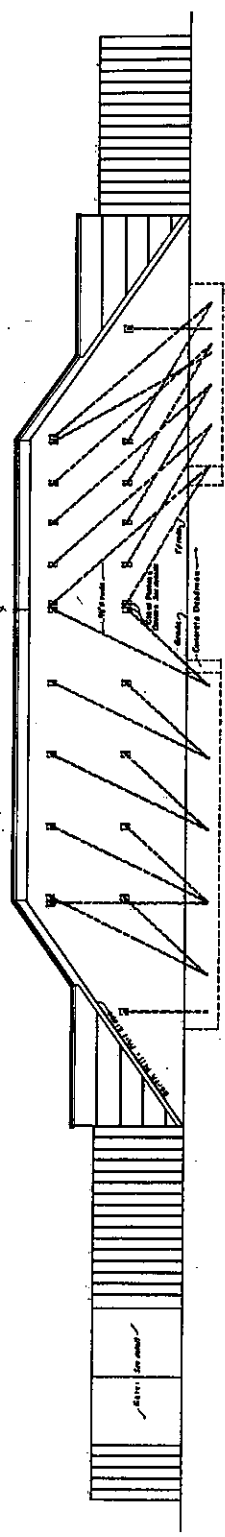
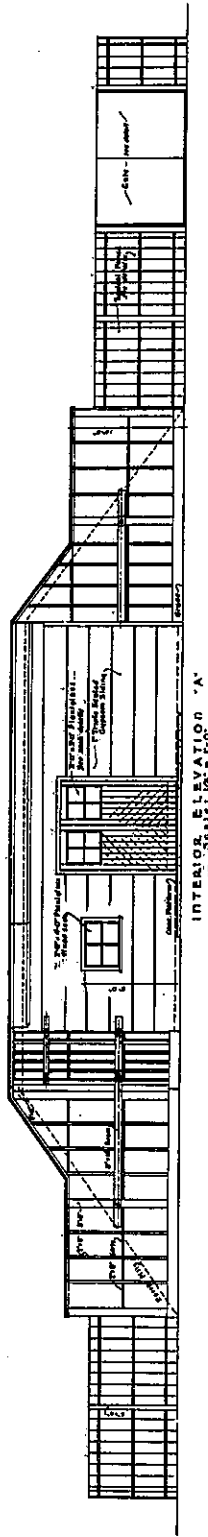

PLANS 16-517 (1-5)

PROJECT NO.	16-517
DATE	1944
DESIGNER	U.S. ENGINEERING OFFICE
CHECKED BY	U.S. ENGINEERING OFFICE
APPROVED BY	U.S. ENGINEERING OFFICE
SCALE	AS SHOWN

ELEVATION SECTION  
SERIES TA-16-517

Building TA-16-517  
LANL DWG. C 6026 (1944)



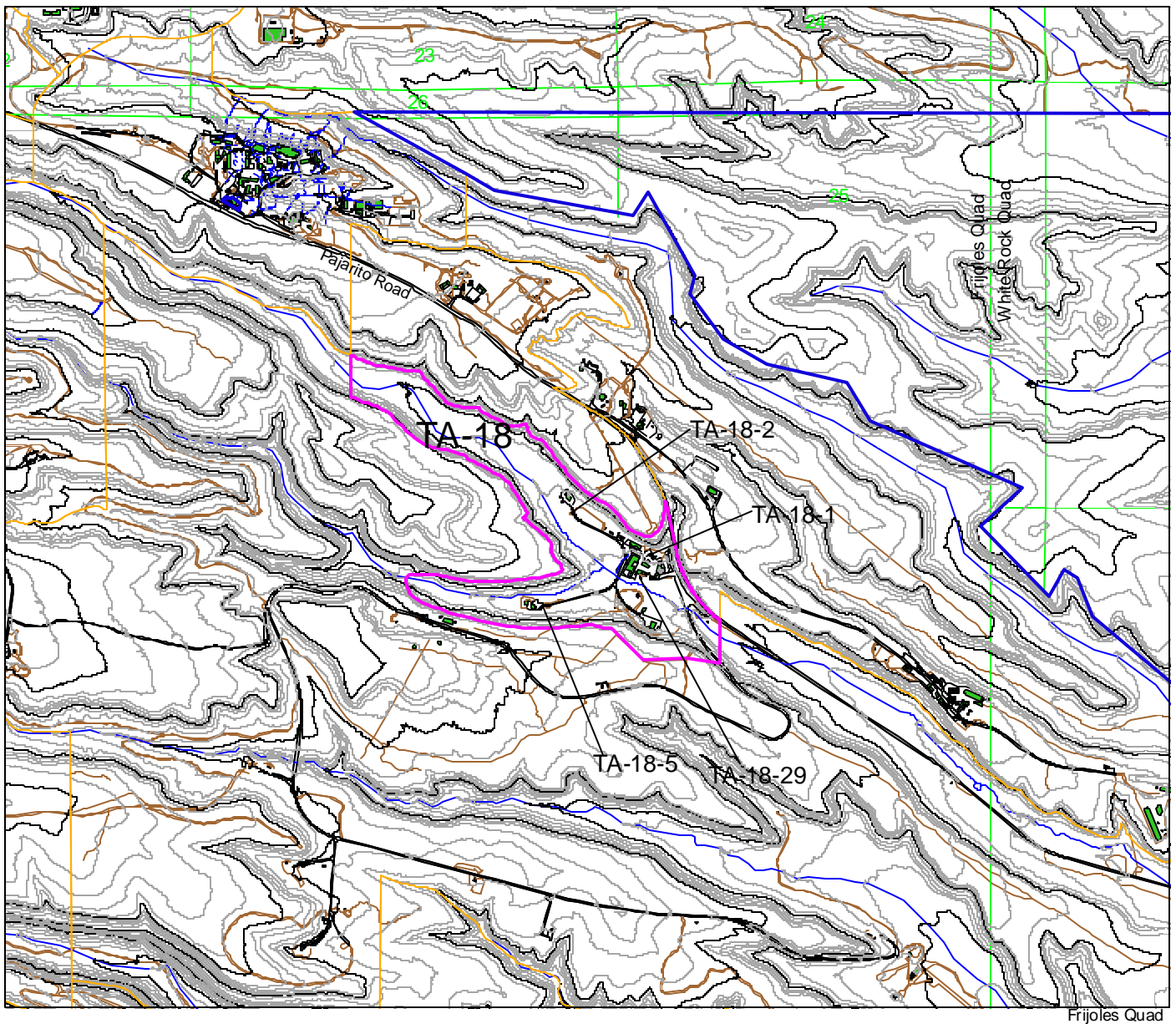

Frijoles Quad

# Los Alamos National Laboratory

Cultural Resources Management Team  
RRES-ECO Ecology Group

1:24000

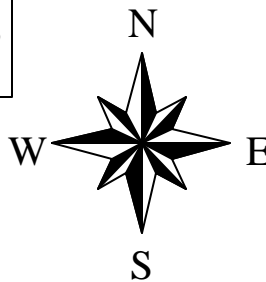

## Manhattan Project Buildings

### TA-18

- Manhattan Project Buildings
- Los Alamos National Laboratory
- Tech Area 18
- Tech Areas
- 20 Foot Contours
- 100 Foot Contours
- Drainage
- Township, Section, Range
- USGS 7.5 Minute Quad
- Roads
- Road dirt
- Park paved
- Park dirt
- Buildings/Structures

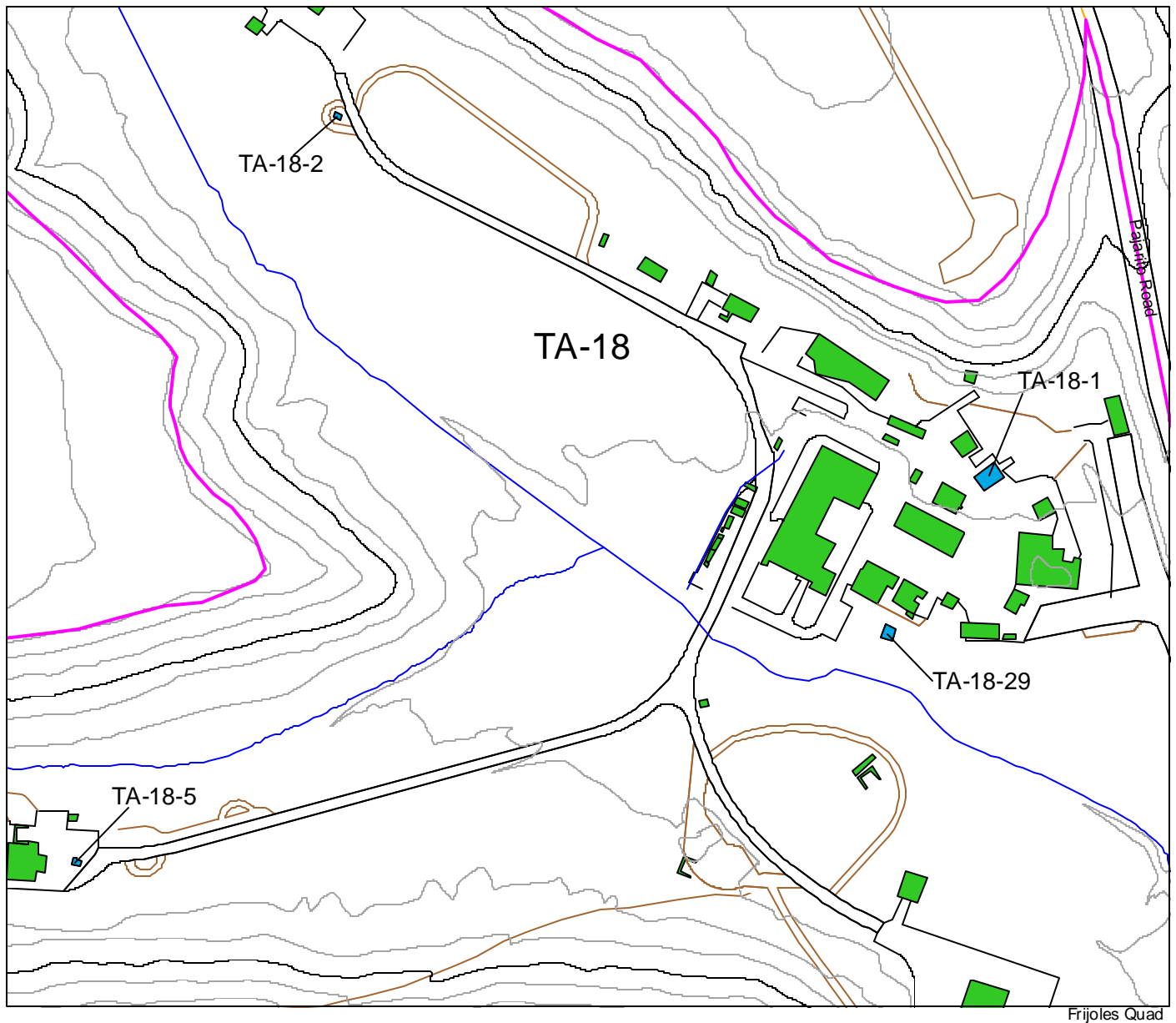

Frijoles Quad

# Los Alamos National Laboratory

Cultural Resources Management Team  
RRES-ECO Ecology Group

1:3000

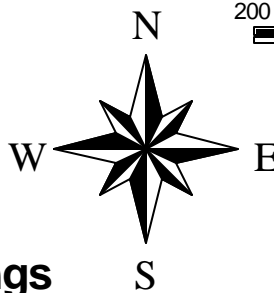
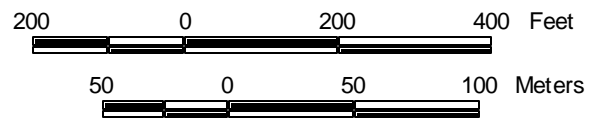

## Manhattan Project Buildings

## TA-18 Closeup

- Manhattan Project Buildings
- Los Alamos National Laboratory
- Tech Area 18
- Tech Areas
- 20 Foot Contours
- 100 Foot Contours
- Drainage
- Township, Section, Range
- USGS 7.5 Minute Quad
- Roads
- Roaddirt
- Parkpave
- Parkdirt
- Buildings/Structures

Map 21



### TA-18-1

**Original Function:** Laboratory/Staging Area

**Current Function:** Vacant

**Historical Significance:** Laboratory work supported implosion testing and criticality research. Slotin accident led to important safety changes.

**Date Constructed:** 1946

**Associated Theme:** Implosion/Critical Assembly/Biomedical and Health Physics

**Eligible?:** Yes – “A”

### **Description:**

TA-18-1 is one and a half stories tall on a small footprint and appears like a loft building. It is a wood-frame building with asphalt impregnated paper and wood sleepers with asbestos shingles. The roof is basically flat with an 8 in. high ridge in the center to provide runoff. A portion of the north elevation is sheathed with corrugated metal siding over the asbestos shingles. The floor slab is elevated to dock height, about 3 ft above the surrounding grade. The concrete stem wall is visible above grade. A concrete dock with access stairs, a double sliding door, and frame and rail for an overhead crane are in place at the south elevation. The windows are wood sash double hung with three-over-three window lights and are situated on the east and west elevations only. The windows are set half way up in the wall space adding the loft image.

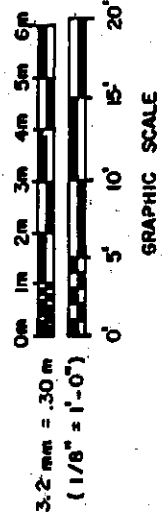
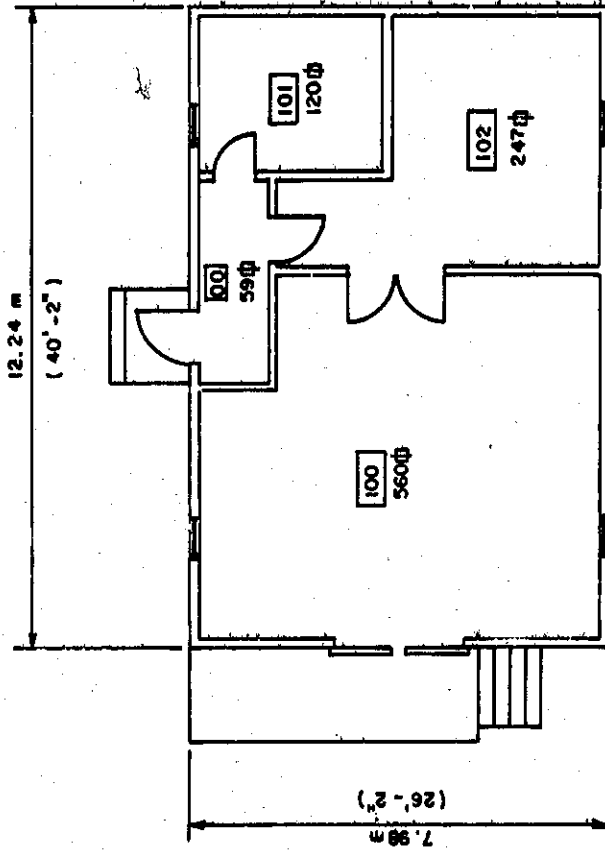

TOTALS: 91.6 m<sup>2</sup> (986) SQ: FT.

NO.	4	REVISED AND REDRAWN TO STATUS OF	9-1-83	DATE	9-1-83	BY	CEC	APP.
UNIVERSITY OF CALIFORNIA		Los Alamos National Laboratory Los Alamos, New Mexico 87545						
Los Alamos		FACILITIES ENGINEERING DIVISION						
LABORATORY BUILDING		SEC. CLASSIFICATION						
FLOOR PLAN		CLASS. 4						
BLDG. PL-1		REVISED <i>Handwritten</i>						
DATE 9-1-83		DATE 10-28-83						
DRAWN BY <i>Handwritten</i>		APPROVED <i>Handwritten</i>						
CHECKED <i>Handwritten</i>		DATE 9-1-83						
SHEET NO. 1 of 1		DRAWING NO. ENG-R2893						

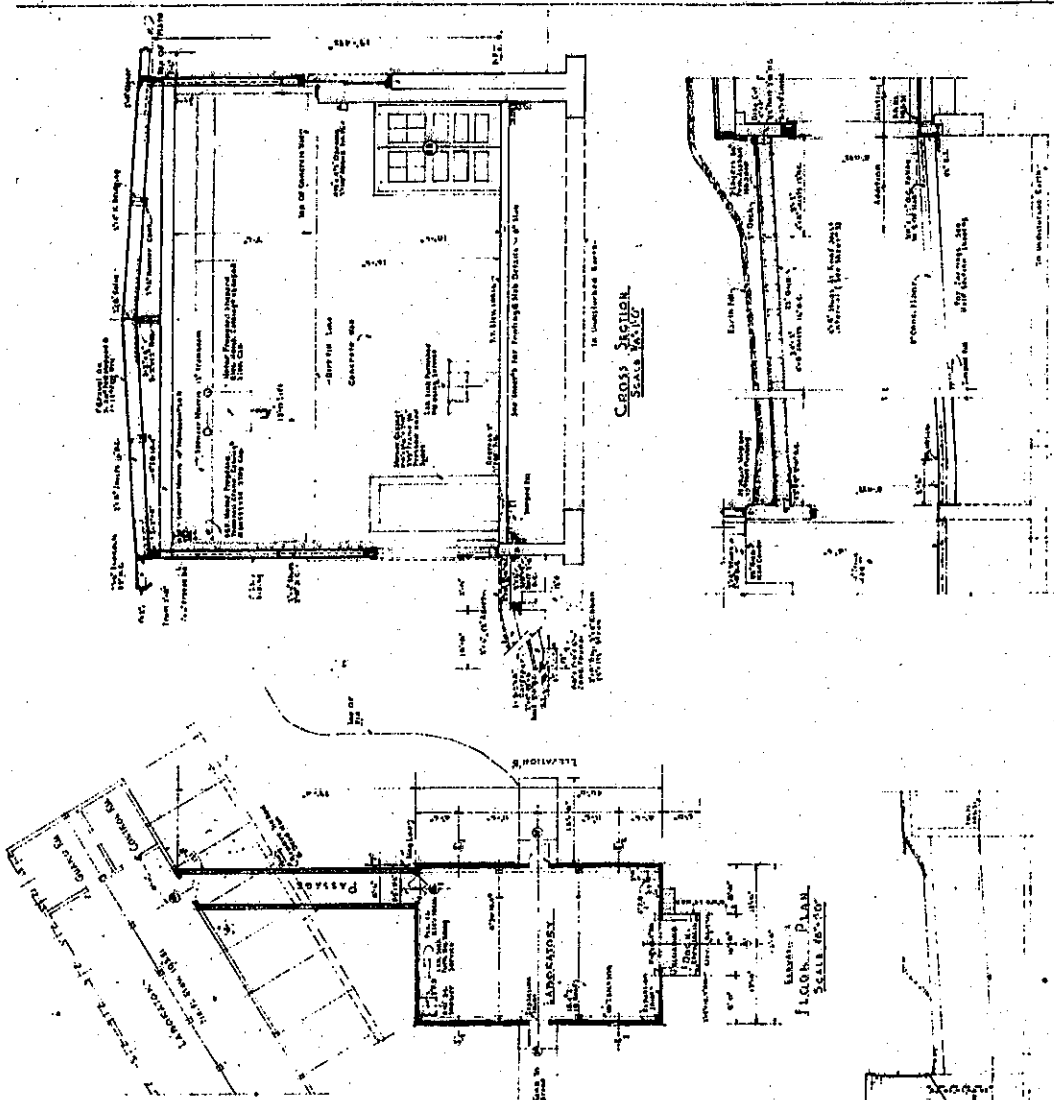

DESIGNER	REVISED TITLE	DATE
ARCHITECT	REVISIONS	BY
<b>U. S. ENGINEER OFFICE</b>		
<b>ADDITION TO QUARTER LABORATORY (L-1)</b>		
<b>FLOOR PLAN, ELEVATIONS &amp; SECTIONS</b>		
NO. 1	DATE	BY
NO. 2	DATE	BY
NO. 3	DATE	BY
NO. 4	DATE	BY
NO. 5	DATE	BY
NO. 6	DATE	BY
NO. 7	DATE	BY
NO. 8	DATE	BY
NO. 9	DATE	BY
NO. 10	DATE	BY
NO. 11	DATE	BY
NO. 12	DATE	BY
NO. 13	DATE	BY
NO. 14	DATE	BY
NO. 15	DATE	BY
NO. 16	DATE	BY
NO. 17	DATE	BY
NO. 18	DATE	BY
NO. 19	DATE	BY
NO. 20	DATE	BY
NO. 21	DATE	BY
NO. 22	DATE	BY
NO. 23	DATE	BY
NO. 24	DATE	BY
NO. 25	DATE	BY
NO. 26	DATE	BY
NO. 27	DATE	BY
NO. 28	DATE	BY
NO. 29	DATE	BY
NO. 30	DATE	BY
NO. 31	DATE	BY
NO. 32	DATE	BY
NO. 33	DATE	BY
NO. 34	DATE	BY
NO. 35	DATE	BY
NO. 36	DATE	BY
NO. 37	DATE	BY
NO. 38	DATE	BY
NO. 39	DATE	BY
NO. 40	DATE	BY
NO. 41	DATE	BY
NO. 42	DATE	BY
NO. 43	DATE	BY
NO. 44	DATE	BY
NO. 45	DATE	BY
NO. 46	DATE	BY
NO. 47	DATE	BY
NO. 48	DATE	BY
NO. 49	DATE	BY
NO. 50	DATE	BY
NO. 51	DATE	BY
NO. 52	DATE	BY
NO. 53	DATE	BY
NO. 54	DATE	BY
NO. 55	DATE	BY
NO. 56	DATE	BY
NO. 57	DATE	BY
NO. 58	DATE	BY
NO. 59	DATE	BY
NO. 60	DATE	BY
NO. 61	DATE	BY
NO. 62	DATE	BY
NO. 63	DATE	BY
NO. 64	DATE	BY
NO. 65	DATE	BY
NO. 66	DATE	BY
NO. 67	DATE	BY
NO. 68	DATE	BY
NO. 69	DATE	BY
NO. 70	DATE	BY
NO. 71	DATE	BY
NO. 72	DATE	BY
NO. 73	DATE	BY
NO. 74	DATE	BY
NO. 75	DATE	BY
NO. 76	DATE	BY
NO. 77	DATE	BY
NO. 78	DATE	BY
NO. 79	DATE	BY
NO. 80	DATE	BY
NO. 81	DATE	BY
NO. 82	DATE	BY
NO. 83	DATE	BY
NO. 84	DATE	BY
NO. 85	DATE	BY
NO. 86	DATE	BY
NO. 87	DATE	BY
NO. 88	DATE	BY
NO. 89	DATE	BY
NO. 90	DATE	BY
NO. 91	DATE	BY
NO. 92	DATE	BY
NO. 93	DATE	BY
NO. 94	DATE	BY
NO. 95	DATE	BY
NO. 96	DATE	BY
NO. 97	DATE	BY
NO. 98	DATE	BY
NO. 99	DATE	BY
NO. 100	DATE	BY

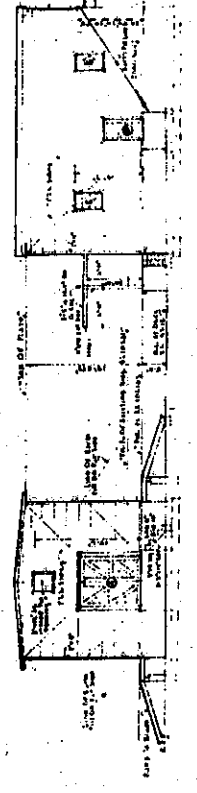
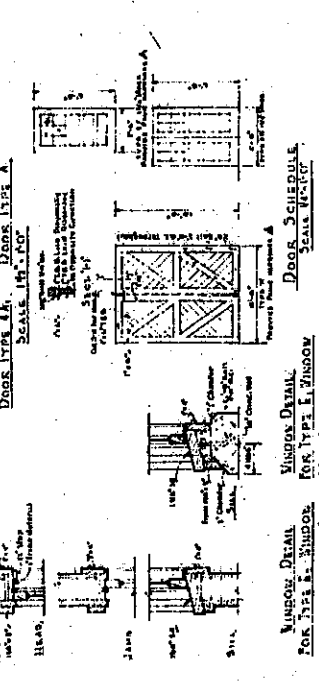
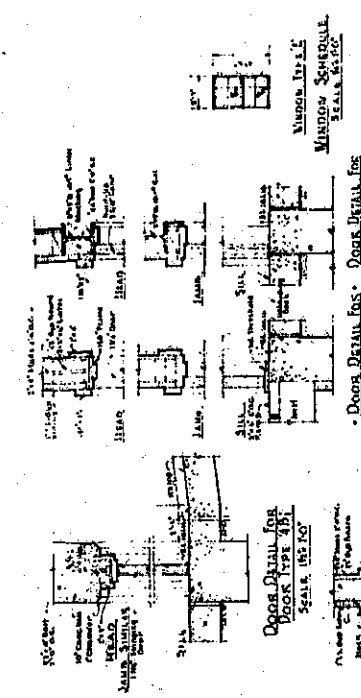

NOTES:  
 1. FINISH EXTERIOR WITH TWO COATS  
 2. PAINT INTERIOR WALLS & CEILING  
 3. PAINT ALL TRIM, DOOR COAT AND  
 4. PAINT INTERIOR WITH TWO COATS  
 5. ALL CONCRETE THICKNESS TO BE  
 6. ALL W. & S. TO BE TO A C.F.T.O.  
 7. SEE PLAN FOR FINISH MARKS THE OTHER



## TA-18-2

**Original Function:** Control Bunker/Battleship Bldg.

**Current Function:** Vacant

**Historical Significance:** Supported tests of the magnetic method of studying implosions.

**Date Constructed:** 1944

**Associated Theme:** Implosion

**Eligible?:** Yes – “A” and “C”

### **Description:**

TA-18-2 is a robust cast-in-place concrete building. The bunker is semi-recessed into the ground and there are no openings other than a blast resistant steel door on the east elevation. The sunken door is accessed down a concrete stair and stairwell. The roof is exposed concrete and no roofing material is apparent. TA-18-2 is also referred to as a “Battleship” building: the west end of the building is bow shaped and shielded with steel plate.



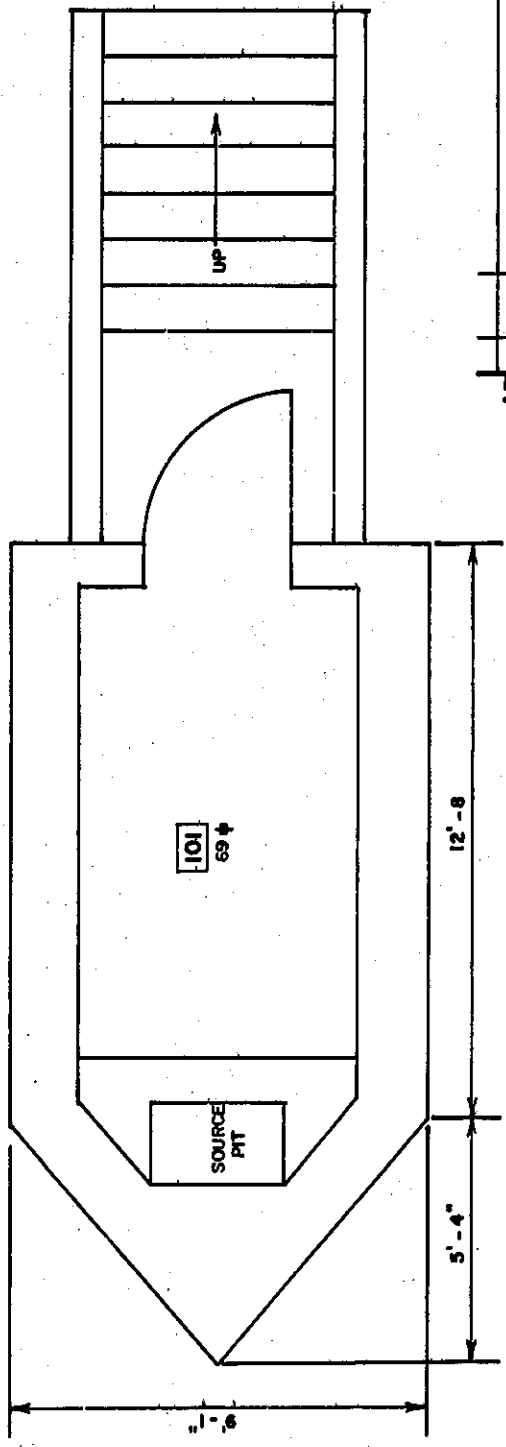

TOTAL SQ. FT. 69

REV	DATE	DESCRIPTION	BY
1	9-1-83	REDESIGN & REVISION TO STATUS OF SEPTEMBER 1982	CEA
2			CEA

UNIVERSITY OF CALIFORNIA  
**Los Alamos**  
Los Alamos National Laboratory  
Los Alamos, New Mexico 87545

FACILITIES ENGINEERING DIVISION

**BATTLESHIP BUILDING**  
**FLOOR PLAN**

BLDG. PL-2 TA-18

DESIGNED BY: *Tom Mc* DRAWN BY: *Donna* CHECKED BY: *W. J. ...*

DATE: 9-1-83

CLASS: 4

REVISIONS: 1-1-83

DATE: 10-21-83

ISSUED BY: *W. J. ...*

PROJECT NO: ENG-R2895

REC'D LOGGED TO VAULT

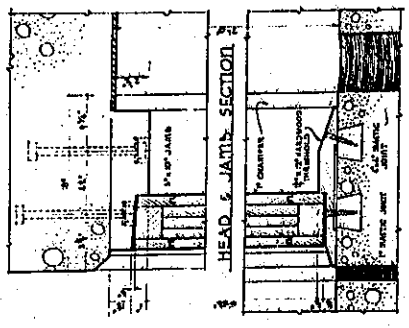

HEAD & JAMB SECTION

SILL SECTION  
SCALE 3/8"=1'-0"

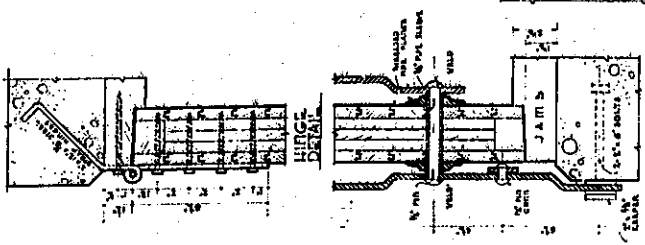

HINGE DETAIL

LATCH DETAIL  
SCALE 3/8"=1'-0"



DOOR DETAILS  
SCALE 3/8"=1'-0"

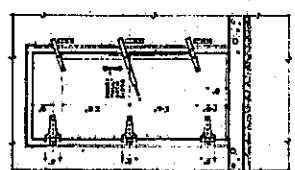

END DOOR ELEVATION  
SCALE 3/8"=1'-0"

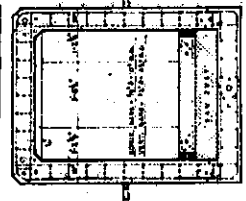

SECTION 'A-A'  
SCALE 3/8"=1'-0"

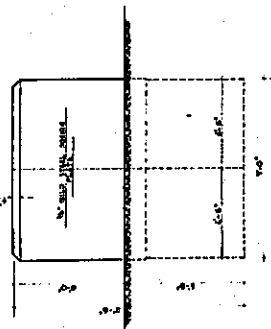

FRONT ELEVATION  
SCALE 3/8"=1'-0"

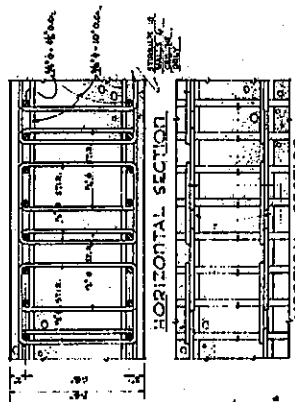

HORIZONTAL SECTION

VERTICAL SECTION  
SCALE 3/8"=1'-0"

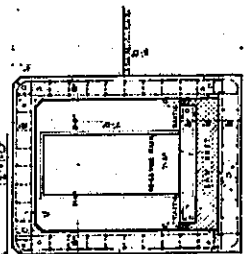

SECTION 'A-A'  
SCALE 3/8"=1'-0"

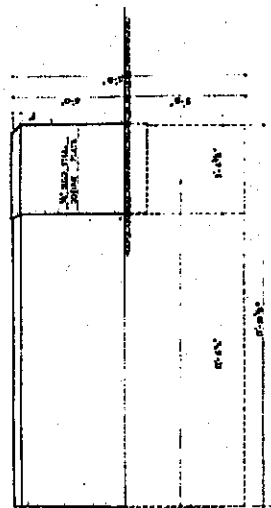

SIDE ELEVATION  
SCALE 3/8"=1'-0"

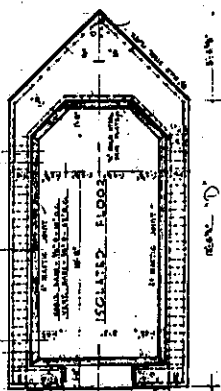

FLOOR PLAN  
SCALE 3/8"=1'-0"

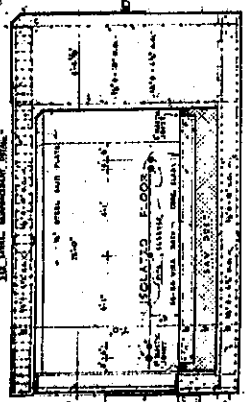

LONGITUDINAL SECTION  
SCALE 3/8"=1'-0"

SECTION 'A-A'  
SCALE 3/8"=1'-0" REVISED TIME 7-28-52 JFM

BLDG # 115 PLAN - ELEVATIONS - SECTIONS - DETAILS

PROJECT  
PAJARITO CONSTRUCTION

U. S. ENGINEER'S OFFICE  
NEW MEXICO

DATE 7/28/52  
SHEET # 6

APPROVED FOR USE SERVICE

SCALE - SEE DIMENSIONS

L.A.S.I. INC. NO. DRG-12050



### TA-18-5

**Original Function:** Control Bunker/Battleship Bldg.

**Current Function:** Vacant

**Historical Significance:** Supported tests of the magnetic method of studying implosions.

**Date Constructed:** 1944

**Associated Theme:** Implosion

**Eligible?:** Yes – “A”

### **Description:**

TA-18-5 is another “Battleship” building and is similar in many respects to TA-18-2. The structure is semi-recessed into the ground with a steel door and exposed concrete roof. The west end of the building is bow shaped and shielded with steel plate. A steel plate access hatch is located on top of the structure’s west end.

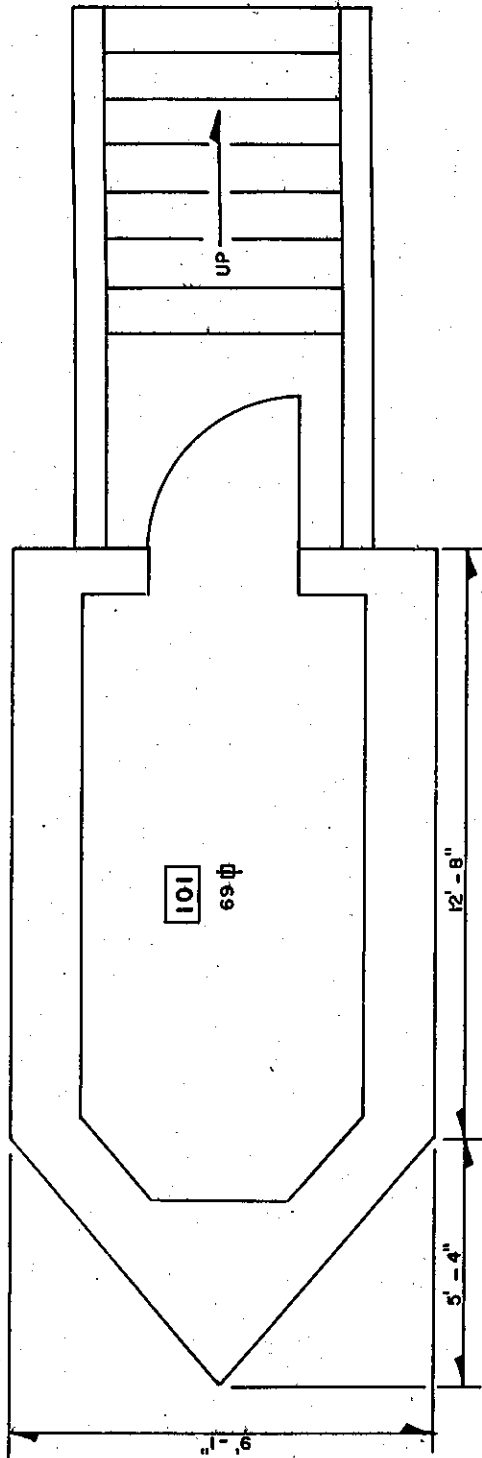

REV.	DATE	DESCRIPTION	BY	CHKD.
1	9-1-83	REDRAWN & REVISED TO STATUS OF SEPTEMBER 01, 1983		
UNIVERSITY OF CALIFORNIA		Los Alamos National Laboratory Los Alamos, New Mexico 97545		
Los Alamos		FACILITIES ENGINEERING DIVISION		
BATTLESHIP BUILDING		SEC. CLASSIFICATION		
FLOOR PLAN		CLASS. 4		
BLDG. PL-5		REVISER: <i>Reid</i>		
APPROVED: <i>[Signature]</i>		DATE: 10-9-83		
RECORDED: <i>[Signature]</i>		APPROVED: <i>[Signature]</i>		
DRAWN: H. G. N.		SHEET NO. 1 OF 1		
CHECKED: <i>[Signature]</i>		DATE: 9-1-83		
		DRAWING NO. ENG-R2896		



TOTAL SQ. FT. 69

REC'D LOGGED TO VAULT *[Signature]*



TA-18-29

**Original Function:** Ranch Cabin  
**Current Function:** Vacant  
**Historical Significance:** Ashley Pond's office and library. Also served as support building for fission and early implosion research.

**Date Constructed:** 1914  
**Associated Theme:** Early Los Alamos (Pre-Lab), and Plutonium and Implosion Research  
**Eligible?:** Yes – "A" (although greatest significance lies with its association with Early Los Alamos history)

**Description** (no drawings available):

TA-18-29 is also known as the Pond Cabin. Built in circa 1913 by Ashley Pond and first used as part of Pond's failed dude ranch, this building was later used to support early Manhattan Project research activities at Pajarito Site (TA-18). The cabin measures 16 ft by 24 ft with an 8 ft high gable roof. The building occupies approximately 384 gross ft<sup>2</sup>. The cabin is rustic in appearance with log walls and a corrugated metal pitched roof. It has three fixed, three-over-three wood windows and one wood door that all appear to be original. One of the original window openings is boarded up. There is one indigenous stone fireplace and chimney. A round metal flue for a wood stove protrudes from the interior through the roof. There are no utility connections to this structure. The condition of the structure is fair with the roof appearing to be in poor but appropriate condition (the building was stabilized in 1986-1987). Some of the metal roof panels have been replaced but others are aged and rusted. Concrete barricades and sand bags surround the structure to divert the threat of flooding; these were placed around the building after the May 2000 Cerro Grande Fire.

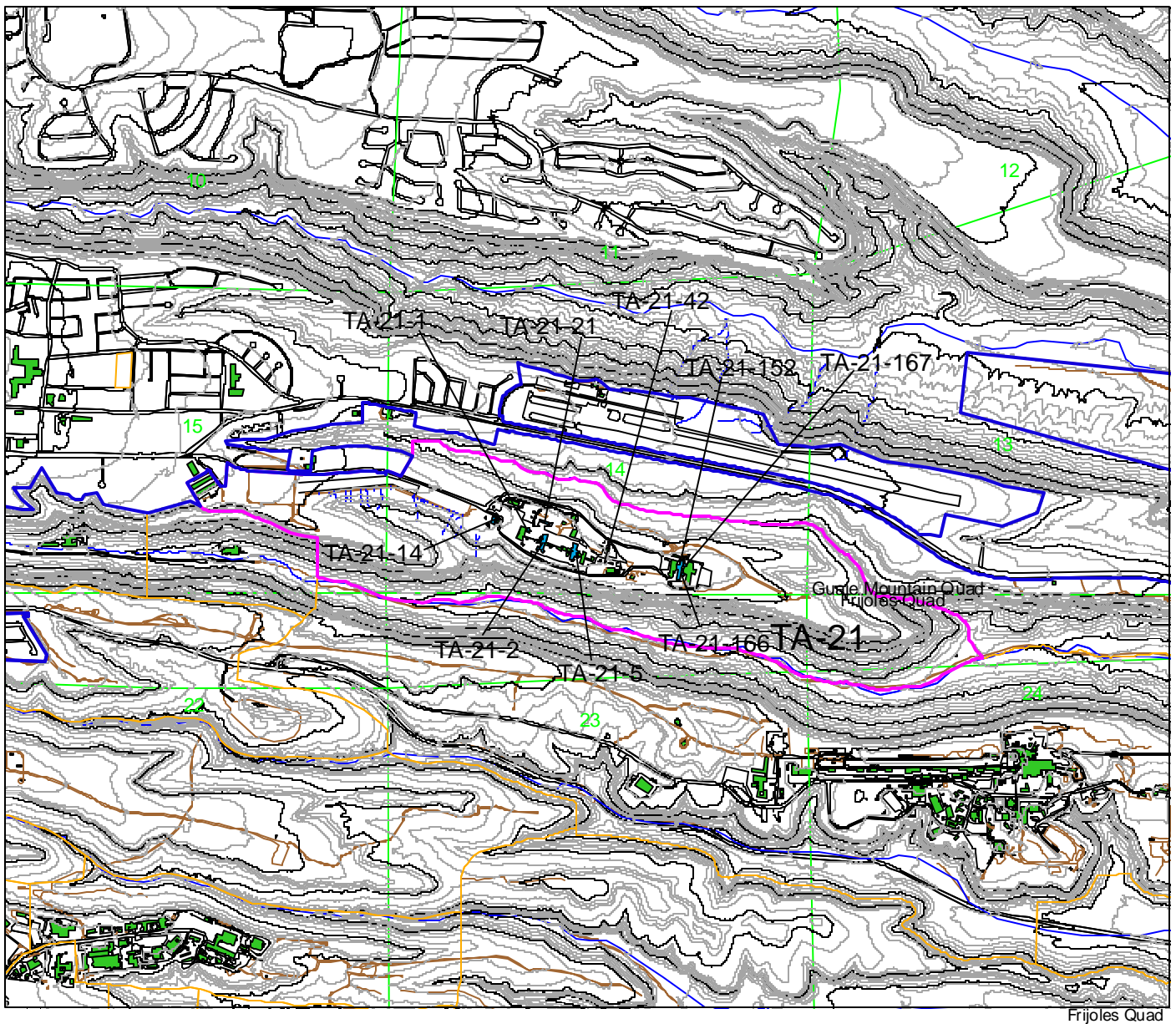

Frijoles Quad

# Los Alamos National Laboratory

Cultural Resources Management Team  
RRES-ECO Ecology Group

1:24000

700 0 700 1400 2100 2800 Feet



200 0 200 400 600 800 Meters

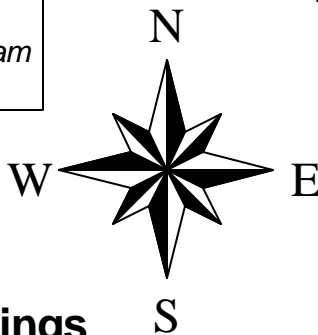

## Manhattan Project Buildings

## TA-21

Map 22

- Manhattan Project Buildings
- Los Alamos National Laboratory
- Tech Area 21
- Tech Areas
- 20 Foot Contours
- 100 Foot Contours
- Drainage
- Township, Section, Range
- USGS 7.5 Minute Quad
- Roads
- Road/dirt
- Park/pave
- Park/dirt
- Buildings/Structures



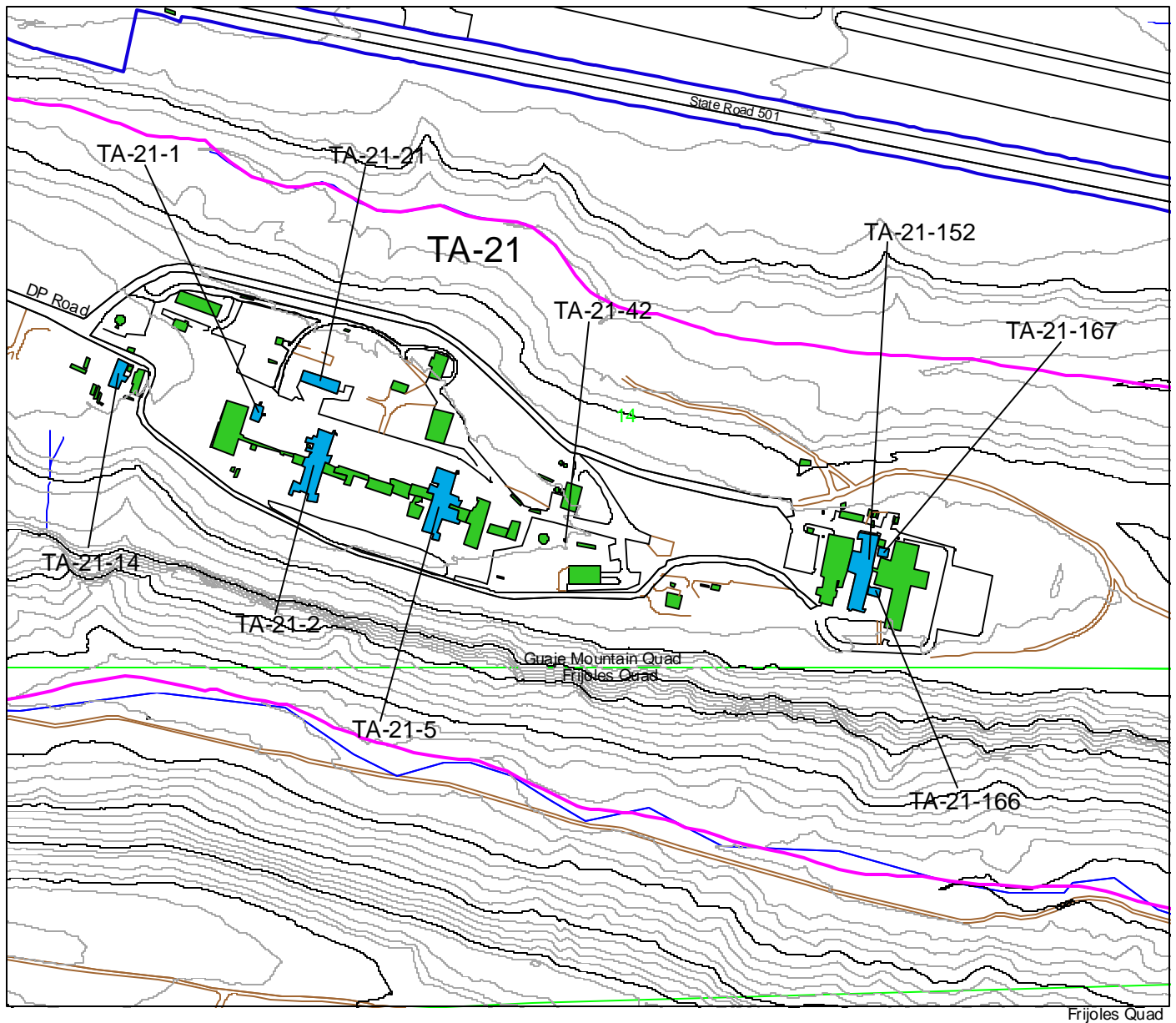

Frijoles Quad

# Los Alamos National Laboratory

Cultural Resources Management Team  
RRES-ECO Ecology Group

1:6000

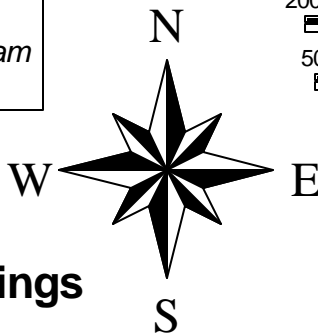
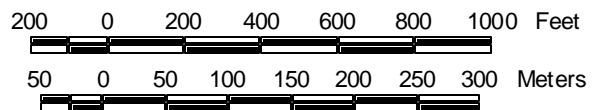

## Manhattan Project Buildings

## TA-21 Closeup

- Manhattan Project Buildings
- ▭ Los Alamos National Laboratory
- ▭ Tech Area 21
- ▭ Tech Areas
- ▭ 20 Foot Contours
- ▭ 100 Foot Contours
- ▭ Drainage
- ▭ Township, Section, Range
- ▭ USGS 7.5 Minute Quad
- ▭ Roads
- ▭ Road/dirt
- ▭ Park/pave
- ▭ Park/dirt
- ▭ Buildings/Structures

Map 23



### TA-21-1

**Original Function:** Office/Vault Bldg.

**Current Function:** Vacant

**Historical Significance:** Supported early plutonium production in support of stockpile.

**Date Constructed:** 1945

**Associated Theme:** Plutonium Production

**Eligible?:** No (extensive remodeling)

### **Description:**

The original building TA-21-1 was the main administrative office building for the plutonium research and processing facility (DP West). The building had a lunch room, lockers, change room, and showers. The original TA-21-1 has been removed; what is present today are two additions: one built in 1949 and one built in 1968. The 1949 addition housed a vault, a records vault room, a quality control office, and the Section Head's office. The 1968 addition consisted of an office and restrooms.

The original building was constructed of metal lath covered with plaster. The 1949 addition was constructed using wood stud walls and steel tube frame filled in with plaster. Exterior wall surfaces are concrete masonry units with stucco finish. Interior walls are gypsum board and some painted concrete masonry units.



ENG-C 27059 (sheet 1 of 10)  
 Office and Toilet Addition  
 Architectural (Floor Plan, Elevations, &  
 Plot Plan)  
 November 19, 1968

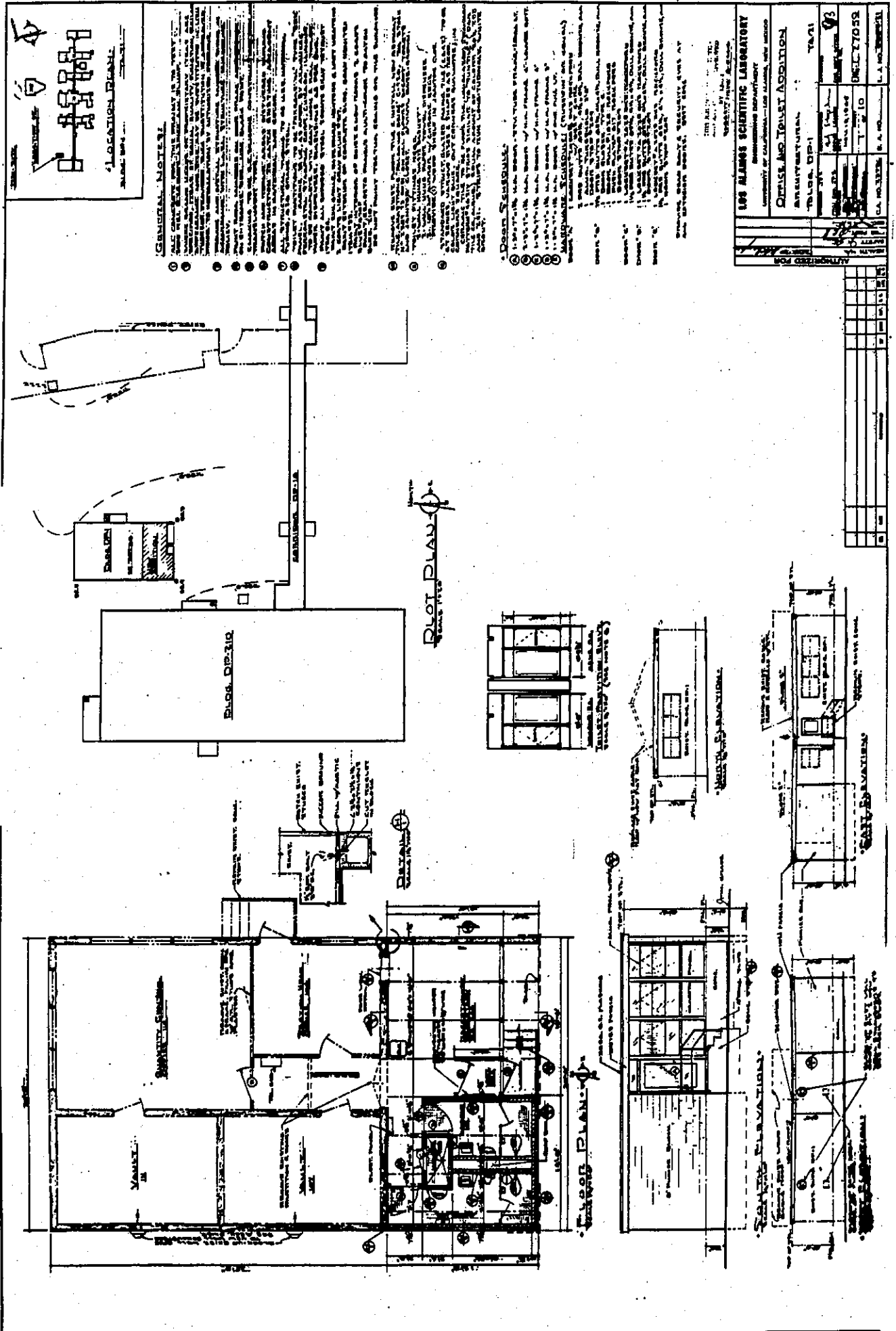

GENERAL NOTES

1. ALL WORK SHALL BE IN ACCORDANCE WITH THE 1968 INTERNATIONAL BUILDING CODE.
2. ALL WORK SHALL BE IN ACCORDANCE WITH THE 1968 CALIFORNIA BUILDING CODE.
3. ALL WORK SHALL BE IN ACCORDANCE WITH THE 1968 LOS ALAMOS SCIENTIFIC LABORATORY BUILDING CODE.
4. ALL WORK SHALL BE IN ACCORDANCE WITH THE 1968 LOS ALAMOS SCIENTIFIC LABORATORY SAFETY CODE.
5. ALL WORK SHALL BE IN ACCORDANCE WITH THE 1968 LOS ALAMOS SCIENTIFIC LABORATORY ENVIRONMENTAL CODE.
6. ALL WORK SHALL BE IN ACCORDANCE WITH THE 1968 LOS ALAMOS SCIENTIFIC LABORATORY FIRE CODE.
7. ALL WORK SHALL BE IN ACCORDANCE WITH THE 1968 LOS ALAMOS SCIENTIFIC LABORATORY RADIOACTIVE MATERIALS CODE.
8. ALL WORK SHALL BE IN ACCORDANCE WITH THE 1968 LOS ALAMOS SCIENTIFIC LABORATORY CHEMICAL CODE.
9. ALL WORK SHALL BE IN ACCORDANCE WITH THE 1968 LOS ALAMOS SCIENTIFIC LABORATORY ELECTRICAL CODE.
10. ALL WORK SHALL BE IN ACCORDANCE WITH THE 1968 LOS ALAMOS SCIENTIFIC LABORATORY MECHANICAL CODE.

LOS ALAMOS SCIENTIFIC LABORATORY  
 UNIVERSITY OF CALIFORNIA - LOS ALAMOS, NEW MEXICO

OFFICE AND TOILET ADDITION

ARCHITECTURE: T.A. JONES

DATE: NOV 19 1968

PROJECT NO: 27059

SCALE: 1" = 20'

BY: T.A. JONES

CHECKED: [Signature]

DATE: [Signature]



### TA-21-2

**Original Function:** Laboratory Building

**Current Function:** Vacant

**Historical Significance:** Supported early plutonium production in support of stockpile. Kelley accident led to safety changes and provided radiation worker dose information.

**Date Constructed:** 1945

**Associated Theme:** Plutonium Production/ Biomedical and Health Physics

**Eligible?:** Yes – “A”

### **Description:**

TA-21-2 is a pre-engineered, steel framed, rectangular warehouse type building with exterior ribbed metal panel siding. The building was used as a plutonium processing and recovery laboratory from 1945 to the 1970s. Ether extraction operations, plutonium-239 and plutonium-241 processing operations, and americium-241 recovery operations were conducted in this building. The Cecil Kelley criticality accident occurred in the south part of TA-21-2 in December of 1958.

ENG-R 2919  
 Laboratory Building, DPW-2, TA-21  
 First Floor Plan  
 October 3, 1983

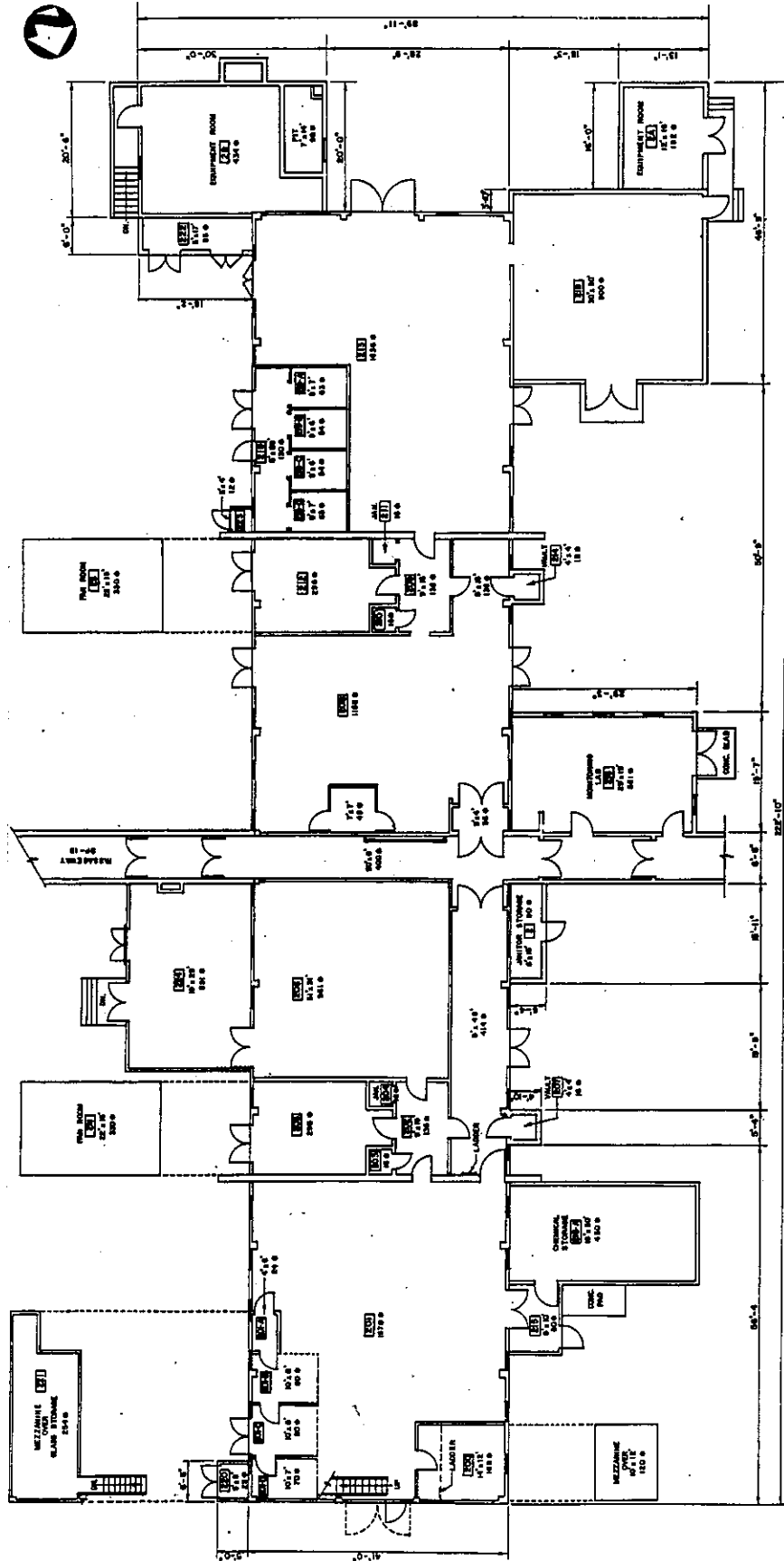

TOTAL SQ. FT. 10,000

NO.	DATE	REVISION
1	10-3-83	ISSUED FOR PERMIT
2	10-3-83	REVISED PER COMMENTS
3	10-3-83	REVISED PER COMMENTS
4	10-3-83	REVISED PER COMMENTS
5	10-3-83	REVISED PER COMMENTS
6	10-3-83	REVISED PER COMMENTS
7	10-3-83	REVISED PER COMMENTS
8	10-3-83	REVISED PER COMMENTS
9	10-3-83	REVISED PER COMMENTS
10	10-3-83	REVISED PER COMMENTS
11	10-3-83	REVISED PER COMMENTS
12	10-3-83	REVISED PER COMMENTS
13	10-3-83	REVISED PER COMMENTS
14	10-3-83	REVISED PER COMMENTS
15	10-3-83	REVISED PER COMMENTS
16	10-3-83	REVISED PER COMMENTS
17	10-3-83	REVISED PER COMMENTS
18	10-3-83	REVISED PER COMMENTS
19	10-3-83	REVISED PER COMMENTS
20	10-3-83	REVISED PER COMMENTS
21	10-3-83	REVISED PER COMMENTS
22	10-3-83	REVISED PER COMMENTS
23	10-3-83	REVISED PER COMMENTS
24	10-3-83	REVISED PER COMMENTS
25	10-3-83	REVISED PER COMMENTS
26	10-3-83	REVISED PER COMMENTS
27	10-3-83	REVISED PER COMMENTS
28	10-3-83	REVISED PER COMMENTS
29	10-3-83	REVISED PER COMMENTS
30	10-3-83	REVISED PER COMMENTS
31	10-3-83	REVISED PER COMMENTS
32	10-3-83	REVISED PER COMMENTS
33	10-3-83	REVISED PER COMMENTS
34	10-3-83	REVISED PER COMMENTS
35	10-3-83	REVISED PER COMMENTS
36	10-3-83	REVISED PER COMMENTS
37	10-3-83	REVISED PER COMMENTS
38	10-3-83	REVISED PER COMMENTS
39	10-3-83	REVISED PER COMMENTS
40	10-3-83	REVISED PER COMMENTS
41	10-3-83	REVISED PER COMMENTS
42	10-3-83	REVISED PER COMMENTS
43	10-3-83	REVISED PER COMMENTS
44	10-3-83	REVISED PER COMMENTS
45	10-3-83	REVISED PER COMMENTS
46	10-3-83	REVISED PER COMMENTS
47	10-3-83	REVISED PER COMMENTS
48	10-3-83	REVISED PER COMMENTS
49	10-3-83	REVISED PER COMMENTS
50	10-3-83	REVISED PER COMMENTS
51	10-3-83	REVISED PER COMMENTS
52	10-3-83	REVISED PER COMMENTS
53	10-3-83	REVISED PER COMMENTS
54	10-3-83	REVISED PER COMMENTS
55	10-3-83	REVISED PER COMMENTS
56	10-3-83	REVISED PER COMMENTS
57	10-3-83	REVISED PER COMMENTS
58	10-3-83	REVISED PER COMMENTS
59	10-3-83	REVISED PER COMMENTS
60	10-3-83	REVISED PER COMMENTS
61	10-3-83	REVISED PER COMMENTS
62	10-3-83	REVISED PER COMMENTS
63	10-3-83	REVISED PER COMMENTS
64	10-3-83	REVISED PER COMMENTS
65	10-3-83	REVISED PER COMMENTS
66	10-3-83	REVISED PER COMMENTS
67	10-3-83	REVISED PER COMMENTS
68	10-3-83	REVISED PER COMMENTS
69	10-3-83	REVISED PER COMMENTS
70	10-3-83	REVISED PER COMMENTS
71	10-3-83	REVISED PER COMMENTS
72	10-3-83	REVISED PER COMMENTS
73	10-3-83	REVISED PER COMMENTS
74	10-3-83	REVISED PER COMMENTS
75	10-3-83	REVISED PER COMMENTS
76	10-3-83	REVISED PER COMMENTS
77	10-3-83	REVISED PER COMMENTS
78	10-3-83	REVISED PER COMMENTS
79	10-3-83	REVISED PER COMMENTS
80	10-3-83	REVISED PER COMMENTS
81	10-3-83	REVISED PER COMMENTS
82	10-3-83	REVISED PER COMMENTS
83	10-3-83	REVISED PER COMMENTS
84	10-3-83	REVISED PER COMMENTS
85	10-3-83	REVISED PER COMMENTS
86	10-3-83	REVISED PER COMMENTS
87	10-3-83	REVISED PER COMMENTS
88	10-3-83	REVISED PER COMMENTS
89	10-3-83	REVISED PER COMMENTS
90	10-3-83	REVISED PER COMMENTS
91	10-3-83	REVISED PER COMMENTS
92	10-3-83	REVISED PER COMMENTS
93	10-3-83	REVISED PER COMMENTS
94	10-3-83	REVISED PER COMMENTS
95	10-3-83	REVISED PER COMMENTS
96	10-3-83	REVISED PER COMMENTS
97	10-3-83	REVISED PER COMMENTS
98	10-3-83	REVISED PER COMMENTS
99	10-3-83	REVISED PER COMMENTS
100	10-3-83	REVISED PER COMMENTS

UNIVERSITY OF CALIFORNIA  
**Los Alamos**  
 Los Alamos National Laboratory  
 Los Alamos, New Mexico 87545

FACILITIES ENGINEERING DIVISION  
 LABORATORY BUILDING  
 FIRST FLOOR PLAN

BLDG. DPW-2  
 TA-21

DATE: 10-3-83  
 DRAWN BY: [Signature]  
 CHECKED BY: [Signature]  
 PROJECT NO.: [Number]  
 SHEET NO.: [Number]  
 TOTAL SHEETS: [Number]  
 SCALE: [Scale]  
 PROJECT: [Project Name]  
 DRAWING NO.: ENG-R2919



ENG-C 2083 (sheet 3)  
 DP Site Construction  
 Bldgs -2, -4, -5 Floor Plan & Elevations  
 March 18, 1945

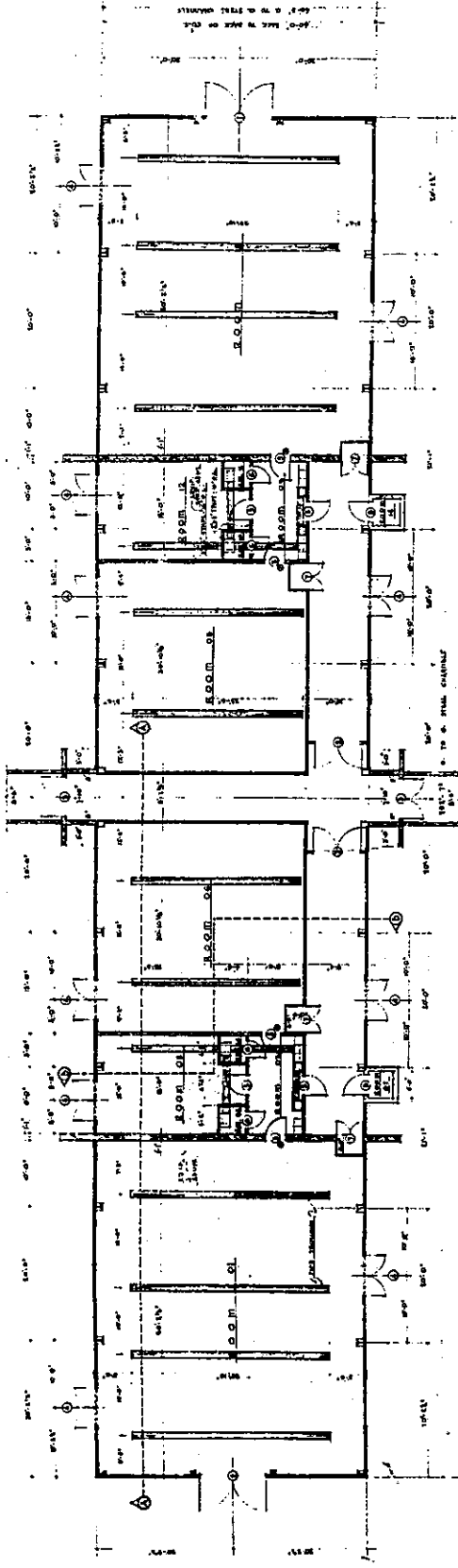

FLOOR PLAN  
 SCALE 1/8" = 1'-0"

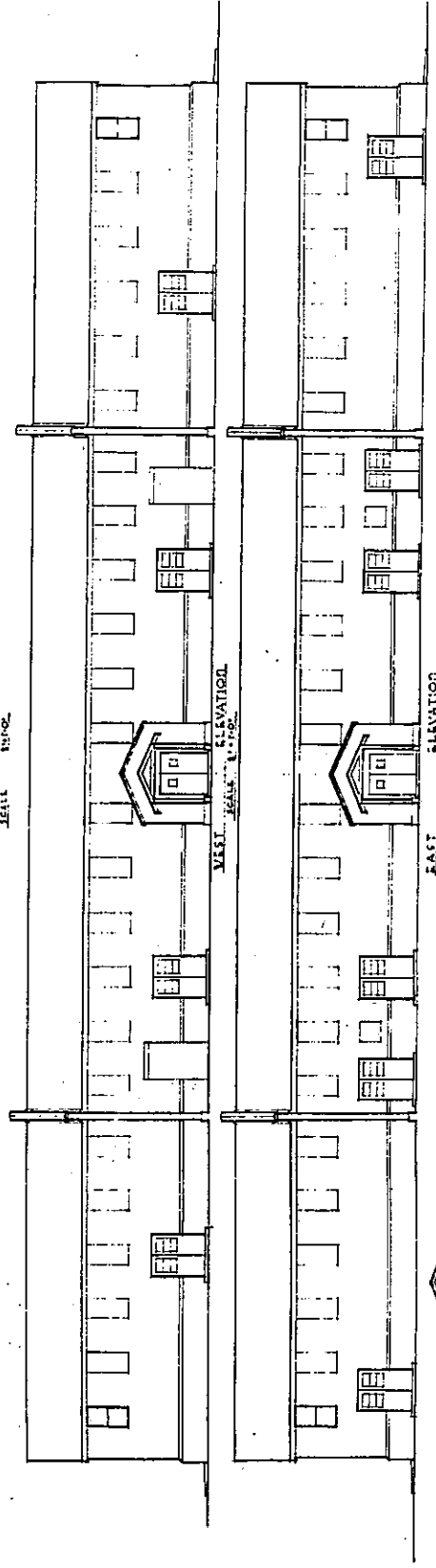

WEST ELEVATION  
 SCALE 1/8" = 1'-0"

EAST ELEVATION  
 SCALE 1/8" = 1'-0"

END ELEVATION  
 SCALE 1/8" = 1'-0"

1. See Title Sheet for  
 PROJECT, LOCATION, METRIC DATA, AREA, VOLUME, E.T.C.  
**BLDG. -2, -4, -5 FLOOR PLAN & ELEVATIONS**  
 PREPARED BY: **DP SITE CONSTRUCTION**  
 DATE: **1945**  
 U.S. ENGINEER, OFFICE  
 WASHINGTON, D. C.  
 SAIDTA PL. D. 07.  
**2083**



### TA-21-5

**Original Function:** Laboratory Building  
**Current Function:** Vacant  
**Historical Significance:** Supported early plutonium production in support of stockpile.

**Date Constructed:** 1945  
**Associated Theme:** Plutonium Production  
**Eligible?:** Yes – “A”

### **Description:**

TA-21-5, like TA-21-2, was part of the first large-scale plutonium processing facility at Los Alamos (known as DP West). Similar in construction to TA-21-2, this building is a steel-framed, rectangular warehouse type building with exterior ribbed metal panel siding. TA-21-5 is still connected to TA-21-2 by way of an umbilical corridor.

The activities conducted in this part of the plutonium processing line included fluoride reduction, metal casting, and machining. In later years, uranium operations were conducted in this building and research on Pu-238 fuels was also carried out.



**ROOM INFORMATION CHART**

RM NO	NET SQ FOOTAGE	RM NO	NET SQ FOOTAGE	RM NO	NET SQ FOOTAGE
501	11.0	502	11.0	503	11.0
504	11.0	505	11.0	506	11.0
507	11.0	508	11.0	509	11.0
510	11.0	511	11.0	512	11.0
513	11.0	514	11.0	515	11.0
516	11.0	517	11.0	518	11.0
519	11.0	520	11.0	521	11.0
522	11.0	523	11.0	524	11.0
525	11.0	526	11.0	527	11.0
528	11.0	529	11.0	530	11.0
531	11.0	532	11.0	533	11.0
534	11.0	535	11.0	536	11.0
537	11.0	538	11.0	539	11.0
540	11.0	541	11.0	542	11.0
543	11.0	544	11.0	545	11.0
546	11.0	547	11.0	548	11.0
549	11.0	550	11.0	551	11.0
552	11.0	553	11.0	554	11.0
555	11.0	556	11.0	557	11.0
558	11.0	559	11.0	560	11.0
561	11.0	562	11.0	563	11.0
564	11.0	565	11.0	566	11.0
567	11.0	568	11.0	569	11.0
570	11.0	571	11.0	572	11.0
573	11.0	574	11.0	575	11.0
576	11.0	577	11.0	578	11.0
579	11.0	580	11.0	581	11.0
582	11.0	583	11.0	584	11.0
585	11.0	586	11.0	587	11.0
588	11.0	589	11.0	590	11.0
591	11.0	592	11.0	593	11.0
594	11.0	595	11.0	596	11.0
597	11.0	598	11.0	599	11.0
600	11.0	601	11.0	602	11.0
603	11.0	604	11.0	605	11.0
606	11.0	607	11.0	608	11.0
609	11.0	610	11.0	611	11.0
612	11.0	613	11.0	614	11.0
615	11.0	616	11.0	617	11.0
618	11.0	619	11.0	620	11.0
621	11.0	622	11.0	623	11.0
624	11.0	625	11.0	626	11.0
627	11.0	628	11.0	629	11.0
630	11.0	631	11.0	632	11.0
633	11.0	634	11.0	635	11.0
636	11.0	637	11.0	638	11.0
639	11.0	640	11.0	641	11.0
642	11.0	643	11.0	644	11.0
645	11.0	646	11.0	647	11.0
648	11.0	649	11.0	650	11.0
651	11.0	652	11.0	653	11.0
654	11.0	655	11.0	656	11.0
657	11.0	658	11.0	659	11.0
660	11.0	661	11.0	662	11.0
663	11.0	664	11.0	665	11.0
666	11.0	667	11.0	668	11.0
669	11.0	670	11.0	671	11.0
672	11.0	673	11.0	674	11.0
675	11.0	676	11.0	677	11.0
678	11.0	679	11.0	680	11.0
681	11.0	682	11.0	683	11.0
684	11.0	685	11.0	686	11.0
687	11.0	688	11.0	689	11.0
690	11.0	691	11.0	692	11.0
693	11.0	694	11.0	695	11.0
696	11.0	697	11.0	698	11.0
699	11.0	700	11.0	701	11.0
702	11.0	703	11.0	704	11.0
705	11.0	706	11.0	707	11.0
708	11.0	709	11.0	710	11.0
711	11.0	712	11.0	713	11.0
714	11.0	715	11.0	716	11.0
717	11.0	718	11.0	719	11.0
720	11.0	721	11.0	722	11.0
723	11.0	724	11.0	725	11.0
726	11.0	727	11.0	728	11.0
729	11.0	730	11.0	731	11.0
732	11.0	733	11.0	734	11.0
735	11.0	736	11.0	737	11.0
738	11.0	739	11.0	740	11.0
741	11.0	742	11.0	743	11.0
744	11.0	745	11.0	746	11.0
747	11.0	748	11.0	749	11.0
750	11.0	751	11.0	752	11.0
753	11.0	754	11.0	755	11.0
756	11.0	757	11.0	758	11.0
759	11.0	760	11.0	761	11.0
762	11.0	763	11.0	764	11.0
765	11.0	766	11.0	767	11.0
768	11.0	769	11.0	770	11.0
771	11.0	772	11.0	773	11.0
774	11.0	775	11.0	776	11.0
777	11.0	778	11.0	779	11.0
780	11.0	781	11.0	782	11.0
783	11.0	784	11.0	785	11.0
786	11.0	787	11.0	788	11.0
789	11.0	790	11.0	791	11.0
792	11.0	793	11.0	794	11.0
795	11.0	796	11.0	797	11.0
798	11.0	799	11.0	800	11.0

TOTAL ROOM NET SQUARE FOOTAGE (THIS SHEET) = 13,689  
 GROSS SQUARE FOOTAGE (THIS SHEET) = 14,120  
 TOTAL ROOM NET SQUARE FOOTAGE (BUILDING) = 26,068  
 GROSS SQUARE FOOTAGE (BUILDING) = 27,039

- LEGEND**
- □ I
  - COLUMNS
  - CONCRETE
  - CONCRETE BLOCK
  - CHAIN LINK FENCE
  - LOUVER SPACE
  - UTILITY SPACE
  - WOOD OR METAL STUD

**NOTES**

1. ALL EXTERIOR WALLS ARE 8" THICK UNLESS OTHERWISE NOTED.
2. ALL INTERIOR WALLS ARE 8" THICK UNLESS OTHERWISE NOTED.
3. ROOM NET SQUARE FOOTAGE IS COMPUTED BY MEASURING FROM THE INSIDE FACE OF EXTERIOR WALLS TO THE CENTERLINE OF ALL OTHER WALLS. AREAS SHOWN ARE ROUNDED TO THE NEAREST SQUARE FOOT.
4. GROSS SQUARE FOOTAGE IS EQUAL TO ALL FLOOR AREA (INCLUDING ALL OPENINGS AT FLOOR SURFACE) MEASURED TO THE OUTER SURFACES OF ALL EXTERIOR WALLS. THIS INCLUDES STAIRS, MEZANINES, MEZZANINES, HALLS, VESTIBULES, STAIRWELLS, SERVICE AND EQUIPMENT ROOMS, PENHOUSES, ENCLOSED PASSAGES AND WALKS, FINISHED 5' FELL OR MORE WITH SLOPING CEILINGS (SUCH AS ATTIC SPACES) OR RECEIVING PLATFORMS AT TRUCK OR RAILROAD CAR HEADS, ALSO INCLUDED IN GROSS FLOOR AREA, BUT CALCULATED ON ONE-HALF OF AREA. THIS INCLUDES OPENED OFFICE PARTICES, PASSAGES AND WALKS, WITH APPLICABLE DIMENSIONS INCLUDING RECEIVING AND SHIPPING PLATFORMS AT TRUCK AND RAILROAD HEIGHT.
5. DIMENSIONS SHOWN ARE ROUNDED TO THE NEAREST INCH.

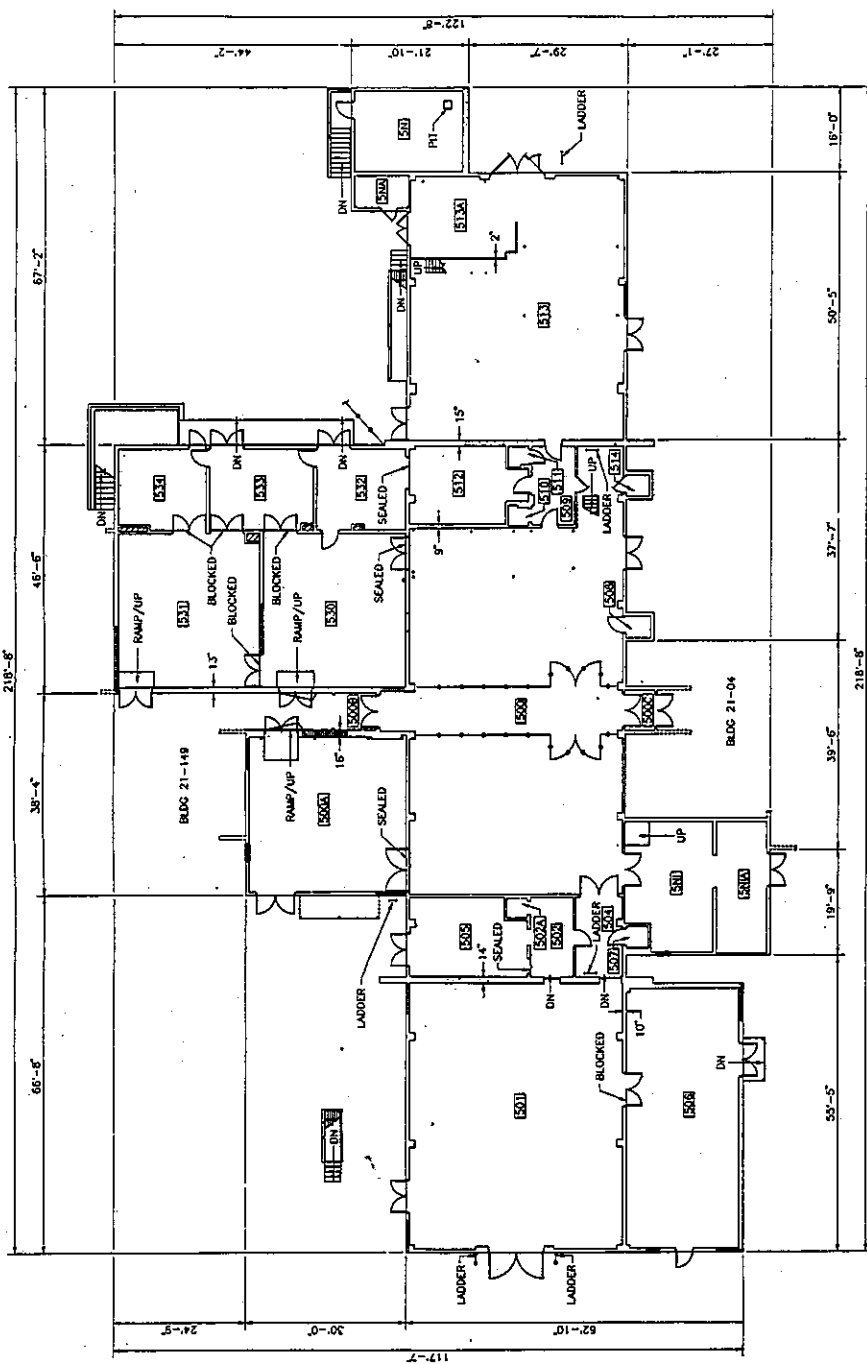

**JOHNSON CONTROLS WORLD SERVICES INC.**

**AS-BUILT RECORD FLOOR PLAN**  
**LABORATORY BUILDING**  
 ARCH. FIRST FLOOR PLAN

BUDG. NO. TA-31  
 DATE: 01-24-94

DESIGNED BY: [Signature]  
 CHECKED BY: [Signature]  
 RELEASED BY: [Signature]

Los Alamos National Laboratory  
 Los Alamos, New Mexico 87545

CLASSIFICATION: UNCLASSIFIED  
 PROJECT # 7556  
 SHEET 2 OF 3  
 DATE 10-26-94  
 AB286

ENG-AB 286 (sheet 2 of 3)  
 Laboratory Building  
 Architectural- Mezzanine and Attic  
 Floor Plan  
 As-Built Record Floor Plan  
 July 20, 1994

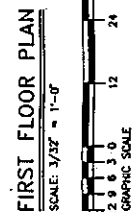

ROOM INFORMATION CHART			
RM NO	RM NO	NET SQ	NET SQ
FOOTAGE	FOOTAGE	FOOTAGE	FOOTAGE
500	501	10.370	10.681
502	503	26.088	26.088
504	505	27.039	27.039

TOTAL ROOM NET SQUARE FOOTAGE (THIS SHEET) = 10.370  
 GROSS SQUARE FOOTAGE (THIS SHEET) = 10.681  
 TOTAL ROOM NET SQUARE FOOTAGE (BUILDING) = 26.088  
 GROSS SQUARE FOOTAGE (BUILDING) = 27.039

**LEGEND**  
 □ COLUMN  
 ▨ CONCRETE  
 ▩ CONCRETE BLOCK

**NOTES**

1. ALL EXTERIOR WALLS ARE 8" THICK U.P.S.S. OTHERWISE NOTED.
2. ALL INTERIOR WALLS ARE 2" THICK UNLESS OTHERWISE NOTED.
3. ROOM NET SQUARE FOOTAGE IS COMPUTED BY MEASURING FROM THE INSIDE FACE OF EXTERIOR WALLS TO THE CENTERLINE OF ALL OTHER WALLS. AREAS SHOWN ARE ROUNDED TO THE NEAREST SQUARE FOOT.
4. GROSS SQUARE FOOTAGE IS EQUAL TO ALL FLOOR AREA (INCLUDING ALL OPENINGS IN FLOOR SLABS) MEASURED TO THE OUTER SURFACES OF EXTERIOR OR ENCLOSURE WALLS, AND INCLUDES ALL FLOORS, MEZANINES, HALLS, VESTIBULES, STAIRWELLS, SERVICE AND EQUIPMENT ROOMS, ELEVATOR SHAFTS, AND ALL OTHER AREAS WITH FINISHED USABLE SPACE WITH SLOPING CEILINGS (SUCH AS ATTIC SPACES) HAVING 5 FEET OR MORE HEADROOM, AND APPENDED COVERED SHIPPING OR RECEIVING AREAS. AREAS WITH HEADROOM LESS THAN 5 FEET ARE INCLUDED IN GROSS FLOOR AREA, BUT CALCULATED ON ONE-HALF OF ACTUAL FLOOR AREA. ARE COVERED OPEN PORCHES, PASSAGES AND WALLS, WITH APPENDED UNCOVERED RECEIVING AND SHIPPING PLATFORMS AT TRUCK AND RAILROAD HEIGHT.
5. DIMENSIONS SHOWN ARE ROUNDED TO THE NEAREST INCH.

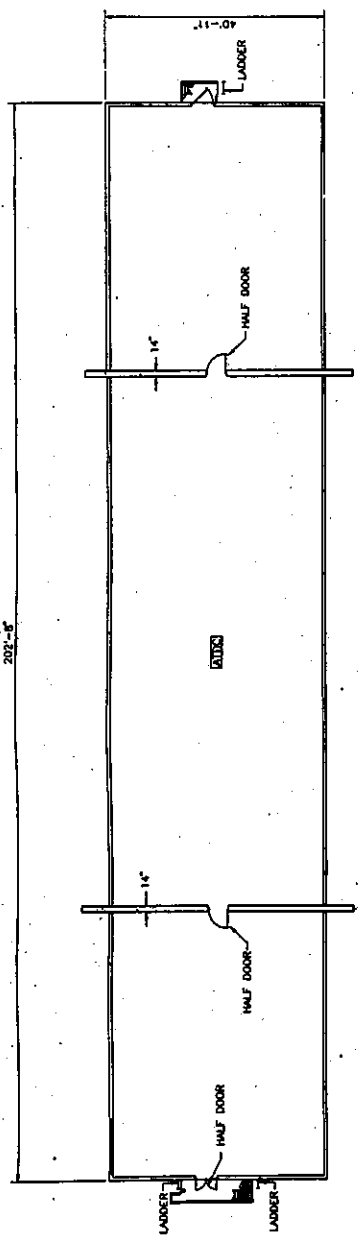

**ATTIC ABOVE RM 501**  
 SCALE: 3/32" = 1'-0"

BLOS 21-149

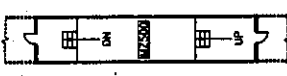

BLOS 21-1

**MEZZANINE ABOVE RM 500**  
 SCALE: 3/32" = 1'-0"

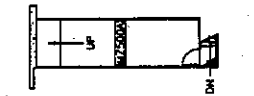

**MEZZANINE ABOVE RM 512**  
 SCALE: 3/32" = 1'-0"

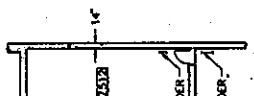

**MEZZANINE ABOVE RM 505**  
 SCALE: 3/32" = 1'-0"

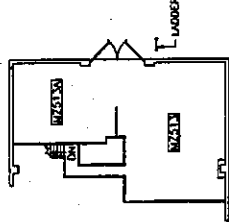

**MEZZANINE ABOVE RM 513 & 513A**  
 SCALE: 3/32" = 1'-0"

NO	DATE	CLASS	DESCRIPTION	BY	CHKD	APP

**JOHNSON CONTROLS WORLD SERVICES INC.**  
 AS-BUILT RECORD FLOOR PLAN  
 LABORATORY BUILDING  
 ARCHITECTURAL MEZZANINE AND ATTIC FLOOR PLAN

BLOS 05  
 DRAWN BY: [Signature]  
 CHECKED BY: [Signature]  
 DATE: 01-30-94

**LOS ANGELES**  
 7556  
 AB286

PROJECT NO: 7556  
 SHEET NO: 3 OF 3  
 DATE: 01-30-94

ENG-AB 286 (sheet 3 of 3)  
 Laboratory Building  
 Architectural- Mezzanine and Attic Floor  
 Plan  
 As Built Record Floor Plan  
 July 20, 1994

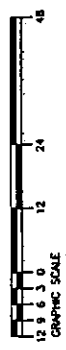

ENG-C 2083 (sheet 3)  
 DP Site Construction  
 Bldgs -2, -4, -5 Floor Plan & Elevations  
 March 18, 1945

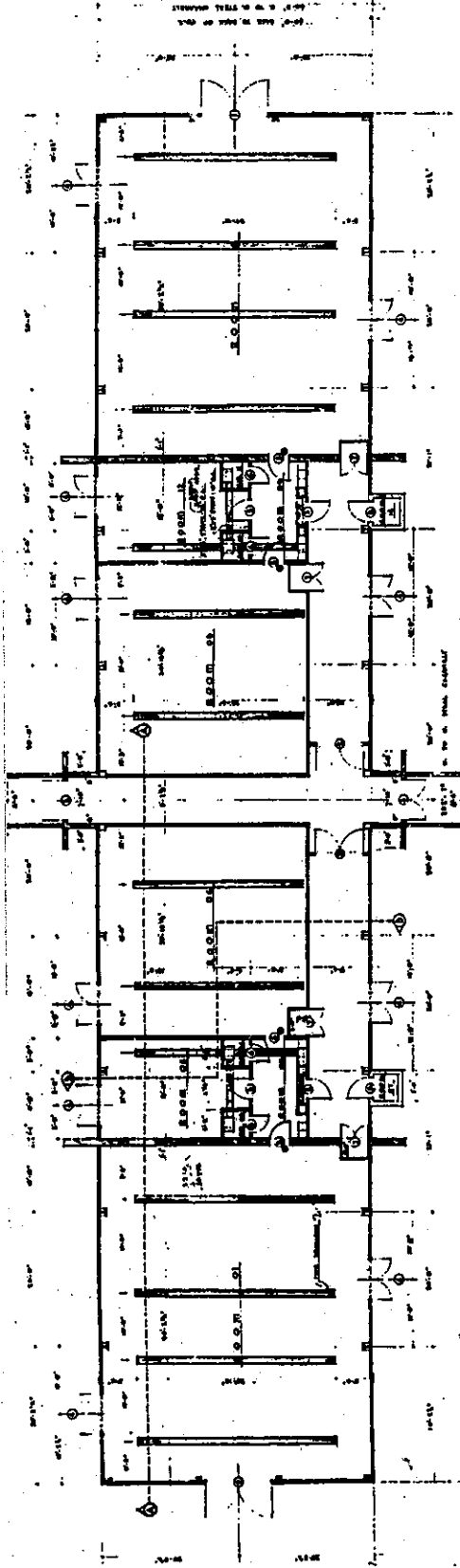

FLOOR PLAN  
 1/8" = 1'-0"

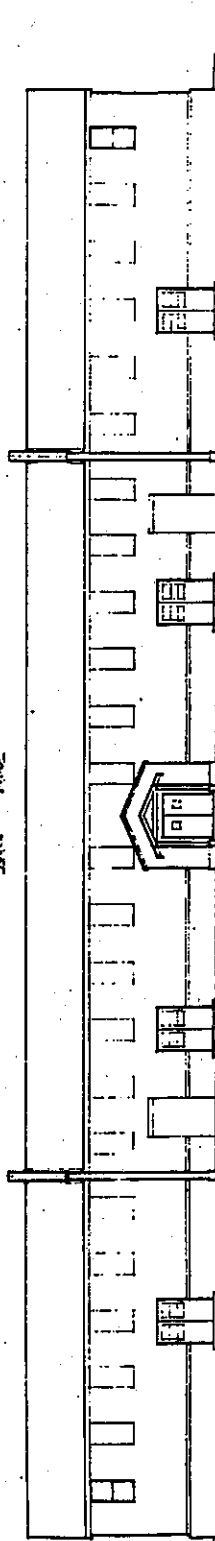

WEST ELEVATION  
 1/8" = 1'-0"

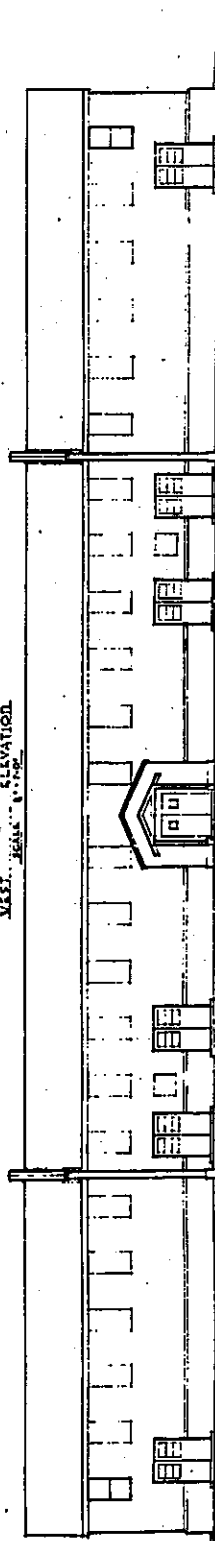

EAST ELEVATION  
 1/8" = 1'-0"

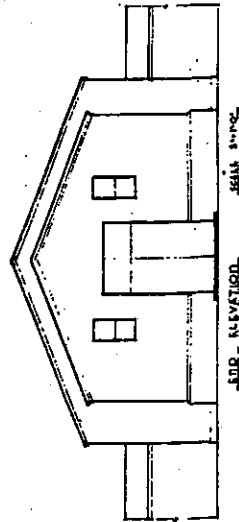

SOUTH ELEVATION  
 1/8" = 1'-0"

BLDGS. 2, 4, 5 FLOOR PLAN & ELEVATIONS DP SITE CONSTRUCTION	
U.S. ENGINEER'S OFFICE WASHINGTON, D. C.	DATE: 3/18/45 DRAWN BY: [Signature] CHECKED BY: [Signature]
PROJECT NO. 2083	





TA-21-14

**Original Function:** Diesel Power Plant  
**Current Function:** Archaeology Laboratory  
**Historical Significance:** Utility support

**Date Constructed:** 1945  
**Associated Theme:** Plutonium  
Production  
**Eligible?:** No (not significant/  
poor integrity)

**Description:**

TA-21-14 was constructed of a steel post and beam structural framework. The building has an asphalt and gravel roof that is sloped slightly from the east to the west for water drainage. The foundation is concrete slab, stem walls, and footings. The walls are constructed of concrete masonry units that have been stuccoed on the exterior surface.

TA-21-14 served as a diesel power plant in support of DP West plutonium processing operations. The building contained engines, fuel oil transfer pumps, fuel unloading pumps, compressors, and other equipment. The building was later used as a general maintenance shop.



ENG-C 2368 (sheet 5 of 16)  
 Power Plant - DP Site (DPW-14)  
 Elevations  
 November 13, 1946

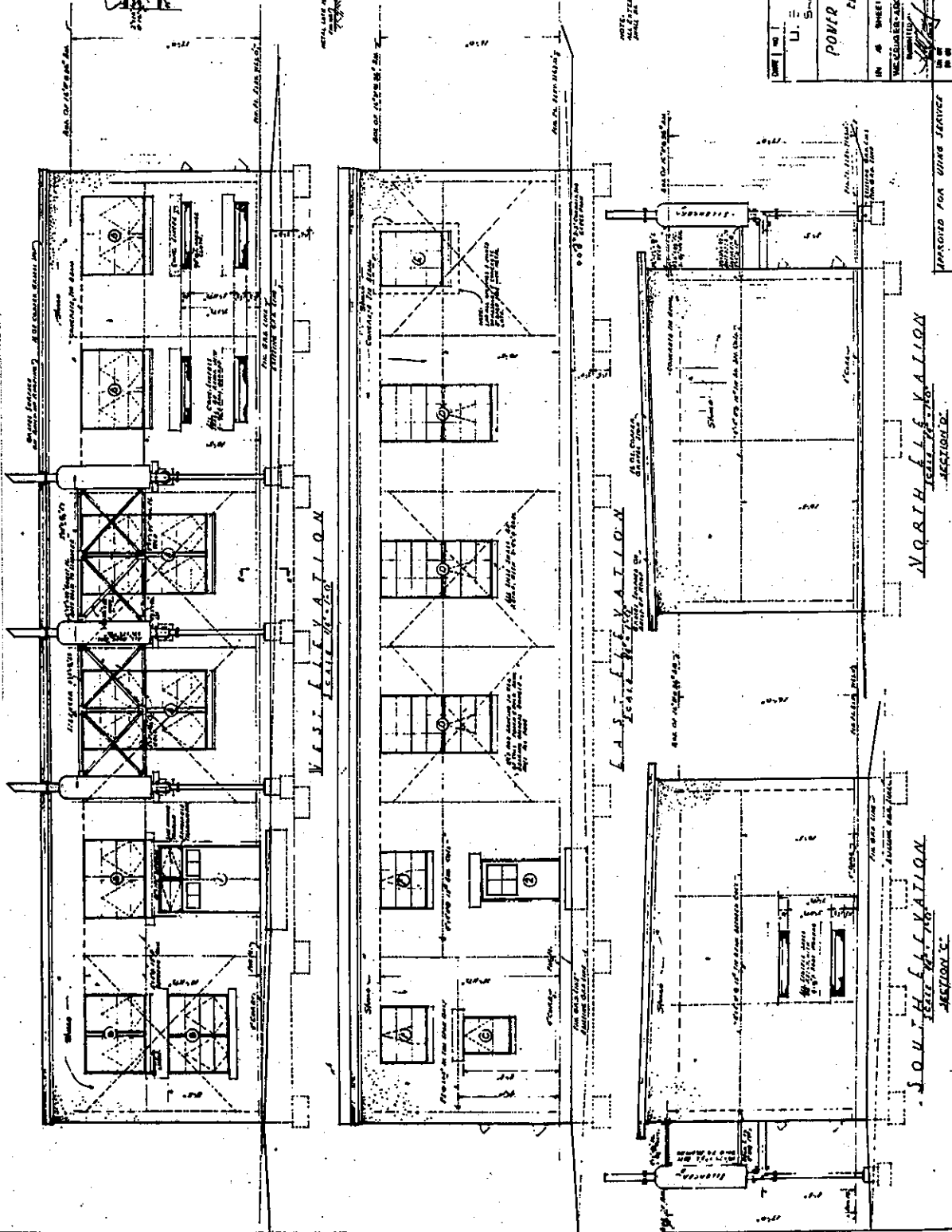

**RECORD DRAWING**  
 THIS DRAWING REPRESENTS  
 THE CONSTRUCTION AS BUILT.

NOTES:  
 1. ALL DIMENSIONS ARE TO FACE UNLESS OTHERWISE SPECIFIED.  
 2. ALL MATERIALS TO BE USED SHALL BE OF THE BEST QUALITY AVAILABLE.  
 3. ALL WORK SHALL BE DONE IN ACCORDANCE WITH THE LATEST EDITIONS OF THE U.S. AND A.S.T.M. SPECIFICATIONS FOR MATERIALS.  
 4. ALL CHANGES SHALL BE MADE BY A CORRECTED DRAWING.  
 5. THIS DRAWING IS THE PROPERTY OF THE U.S. GOVERNMENT AND IS LOANED TO YOU FOR YOUR INFORMATION ONLY. IT IS NOT TO BE REPRODUCED OR TRANSMITTED IN ANY FORM OR BY ANY MEANS, ELECTRONIC OR MECHANICAL, INCLUDING PHOTOCOPYING, RECORDING, OR BY ANY INFORMATION STORAGE AND RETRIEVAL SYSTEM, WITHOUT PERMISSION IN WRITING FROM THE U.S. GOVERNMENT.

DATE	BY	U.S. ENGINEER	OFFICE
		SAN ANTONIO, TEXAS	CD
POWER PLANT - DP SITE - DPW-14			
ELEVATIONS			
SHEET NO.	TOTAL SHEETS	DATE	SCALE
15	16	NOV. 1946	AS SHOWN
APPROVED FOR CONSTRUCTION		APPROVED FOR RECORD	
[Signature]		[Signature]	
FILE NO. PE 416		A.C. FILE NO. 2368	

U.S. GOVERNMENT PRINTING OFFICE: 1946



TA-21-21

**Original Function:** Storage Vault

**Current Function:** Vacant

**Historical Significance:** Supported early plutonium and uranium production in support of stockpile.

**Date Constructed:** 1946

**Associated Theme:** Plutonium  
Production/Stockpile

**Eligible?:** Yes – “A”

**Description:**

Building TA-21-21 stored special fissile material produced in the main plutonium processing facility, DP West. It is a 2,967 ft<sup>2</sup> concrete building, void of window openings, with a flat roof. The roof is constructed on multi-ply composite roofing material (felt, tar, and gravel). There is galvanized steel flashing around the roof. The foundation and walls are reinforced concrete.

ENG-R 2936  
Vault  
Floor Plan  
October 31, 1983

NO.	DATE	REVISIONS	BY	CHKD	GRP	ENG
1	8-18-65	REVISED TO STATUS OF 8-11-65	MFM	MB	MB	MB
2	10-2-74	REVISED AS OF ENG. DWG. C-41127	B.H.	MB	MB	MB

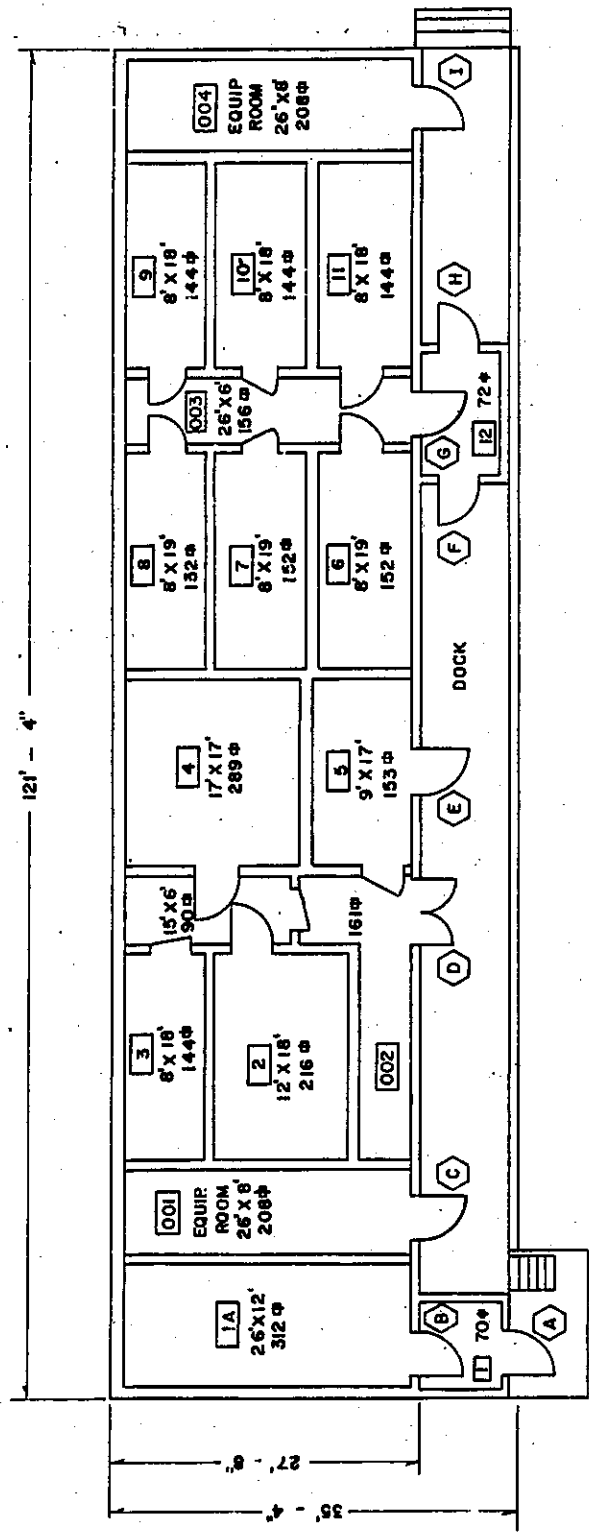

MF	9-9-83	REVISED TO STATUS OF 9-9-83	REVISION	BY	CHKD	GRP	ENG
UNIVERSITY OF CALIFORNIA							
Los Alamos							
Los Alamos National Laboratory Los Alamos, New Mexico 87545							
FACILITIES ENGINEERING DIVISION							
BLDG. DP 21							
VAULT FLOOR PLAN							
TA-21							
REC. CLASSIFICATION							
CLASS. 4							
REVISOR: <i>[Signature]</i>							
DATE: 10-26-83							
APPROVED: <i>[Signature]</i>							
DATE: 1-22-83							
SHEET NO. 1 OF 1							
DRAWING NO. ENG-R2936							

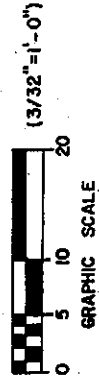

REVIEWER: *[Signature]*  
CLASS. 4 DATE 10/21/83

REC'D LOGGED TO VAULT

ENG-PL 86 (sheet 3 of 4)  
 Storage Vault Addition (For SF Material)  
 Floor Plans & Elevations  
 "Design Criteria"

June 4, 1959

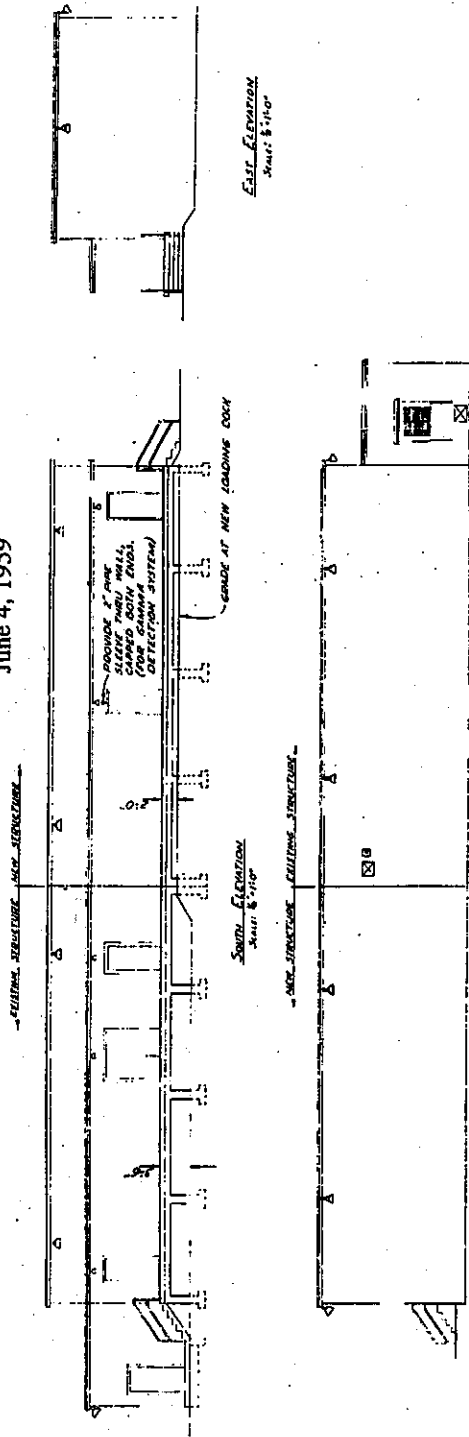

**LEGEND**  
 □ DOOR NUMBER  
 ○ IS AMPLE, DUPLEX GROUNDED RECEPTACLE, TYPE 300V  
 ▼ TELEPHONE OUTLET  
 ○ DOOR TYPE

NOTE: DIMENSIONS IN PARENTHESES ( ) ARE FUNCTIONAL REQUIREMENTS OF L.A.S.

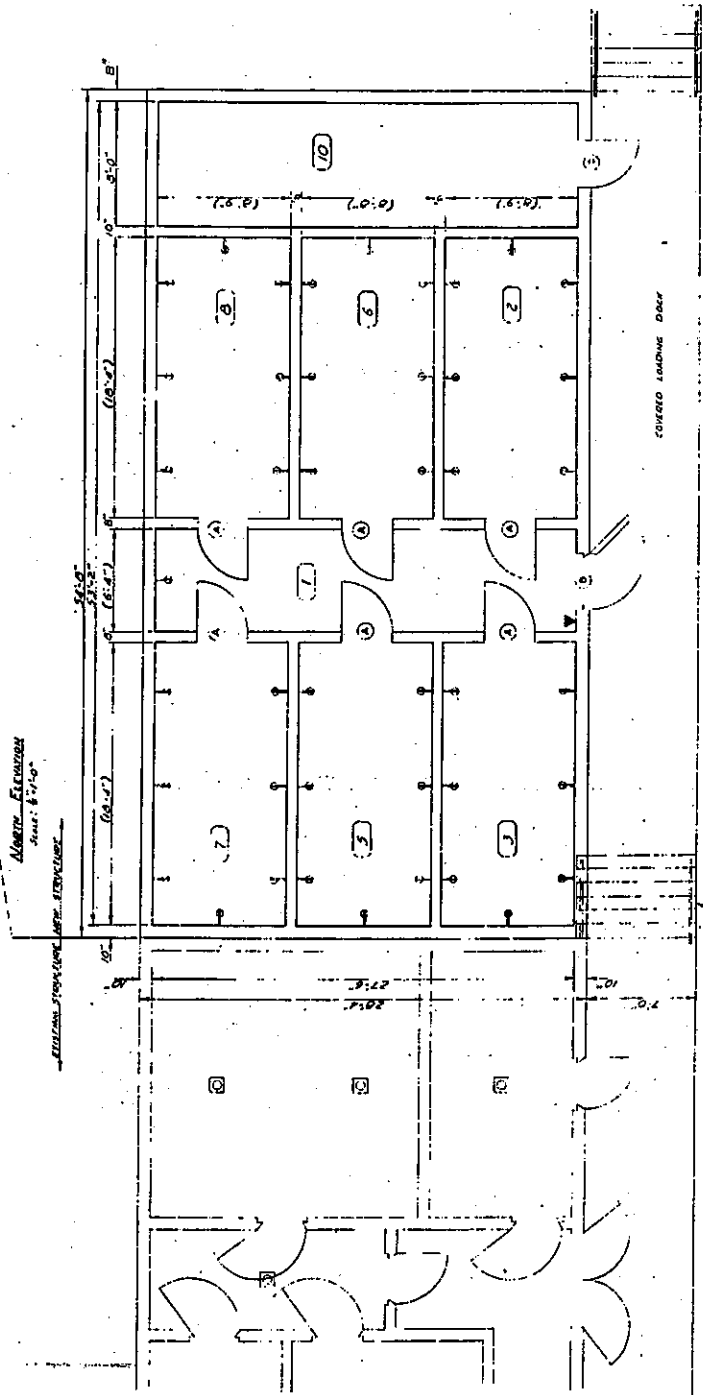

FLOOR PLAN  
 Scale: 1/4" = 1'-0"

DATE	BY	APPROVED	DATE
10/15/59	C. K.	[Signature]	4/15/59
PROJECT		NO. OF SHEETS	NO. OF SHEETS
STORAGE VAULT ADDITION		3	4
UNIVERSITY OF CALIFORNIA - LOS ANGELES		ENGINEER	ENG-PL-86
LOS ANGELES SCIENTIFIC LABORATORY		ENGINEERING DEPARTMENT	
UNIVERSITY OF CALIFORNIA - LOS ANGELES, NEW MEDICO			

"DESIGN CRITERIA"





## TA-21-42

**Original Function:** Pump House  
**Current Function:** Same (in use?)  
**Historical Significance:** Utility support for TA-21 operations.

**Date Constructed:** 1945  
**Associated Theme:** Plutonium Production/ Initiator Development (Support)  
**Eligible?:** No (not significant)

### **Description** (no drawings available):

TA-21-42 is an oil pump house that supports the TA-21 steam plant. The pump house is a utilitarian, concrete masonry unit and wood-frame building with a flat, slightly pitched roof. The foundation is concrete slab and footings, and the exterior walls are covered with stucco. TA-21-42 is approximately 64 ft<sup>2</sup> in size and has a pedestrian door with a two-over-two window.



### TA-21-152

**Original Function:** Laboratory Building  
**Current Function:** Laboratory Building  
**Historical Significance:** Supported initiator research and development, high-temperature chemistry research, and tritium research.

**Date Constructed:** 1945  
**Associated Theme:** Initiator Development, Nuclear Propulsion, Tritium R&D  
**Eligible?:** Yes – “A”

### **Description:**

TA-21-152 was originally a laboratory for polonium initiator research and production. High-temperature chemistry work continued at this building in support of Project Rover, a nuclear rocket program. Since 1977, tritium research has been conducted in this building. TA-21-152 is an industrial, pre-engineered metal lath and plaster building with ribbed metal siding and a pitched roof. All doors and window frames are metal.

ENG-AB 628  
 Laboratory Building  
 Architecture: Record Floor Plan  
 As-Built Record Floor Plan  
 May 15, 1996

ROOM INFORMATION CHART			
RM NO	NET SQ FOOTAGE	RM NO	NET SQ FOOTAGE
100	100	100	100
101	101	101	101
102	102	102	102
103	103	103	103
104	104	104	104
105	105	105	105
106	106	106	106
107	107	107	107
108	108	108	108
109	109	109	109
110	110	110	110
111	111	111	111
112	112	112	112
113	113	113	113
114	114	114	114
115	115	115	115
116	116	116	116
117	117	117	117
118	118	118	118
119	119	119	119
120	120	120	120
121	121	121	121
122	122	122	122
123	123	123	123
124	124	124	124
125	125	125	125
126	126	126	126
127	127	127	127
128	128	128	128
129	129	129	129
130	130	130	130
131	131	131	131
132	132	132	132
133	133	133	133
134	134	134	134
135	135	135	135
136	136	136	136
137	137	137	137
138	138	138	138
139	139	139	139
140	140	140	140
141	141	141	141
142	142	142	142
143	143	143	143
144	144	144	144
145	145	145	145
146	146	146	146
147	147	147	147
148	148	148	148
149	149	149	149
150	150	150	150
151	151	151	151
152	152	152	152
153	153	153	153
154	154	154	154
155	155	155	155
156	156	156	156
157	157	157	157
158	158	158	158
159	159	159	159
160	160	160	160
161	161	161	161
162	162	162	162
163	163	163	163
164	164	164	164
165	165	165	165
166	166	166	166
167	167	167	167
168	168	168	168
169	169	169	169
170	170	170	170
171	171	171	171
172	172	172	172
173	173	173	173
174	174	174	174
175	175	175	175
176	176	176	176
177	177	177	177
178	178	178	178
179	179	179	179
180	180	180	180
181	181	181	181
182	182	182	182
183	183	183	183
184	184	184	184
185	185	185	185
186	186	186	186
187	187	187	187
188	188	188	188
189	189	189	189
190	190	190	190
191	191	191	191
192	192	192	192
193	193	193	193
194	194	194	194
195	195	195	195
196	196	196	196
197	197	197	197
198	198	198	198
199	199	199	199
200	200	200	200

TOTAL ROOM NET SQUARE FOOTAGE (BUILDING) = 12,133  
 GROSS SQUARE FOOTAGE (BUILDING) = 12,451

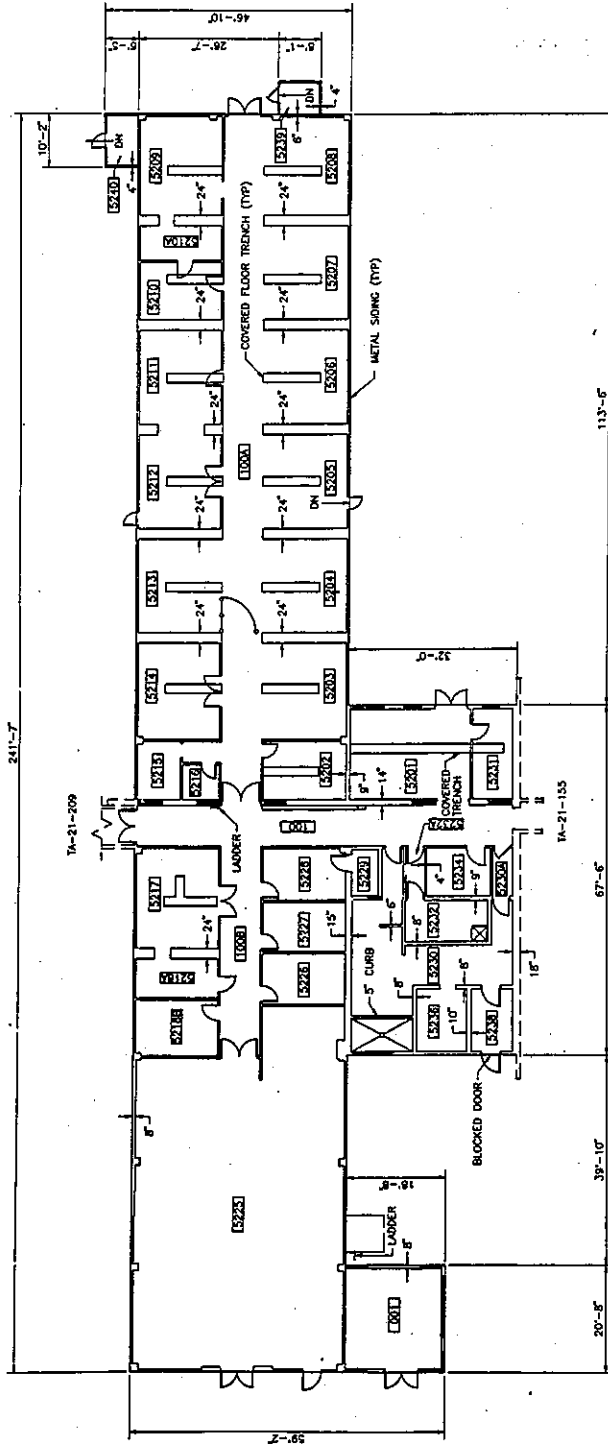

- LEGEND
- BRICK
  - CONCRETE BLOCK
  - COVER
  - WOOD OR METAL STUD
  - CHAIN LINK FENCE
  - COLUMNS

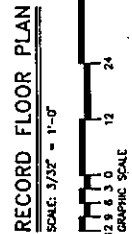

- NOTES
1. ALL EXTERIOR WALLS ARE 6" THICK UNLESS OTHERWISE NOTED.
  2. ALL INTERIOR WALLS ARE 5" THICK UNLESS OTHERWISE NOTED.
  3. REFERENCE DRAWING ENG-R1236
  4. ROOM NET SQUARE FOOTAGE IS COMPUTED BY MEASURING FROM THE INSIDE FACE OF EXTERIOR WALLS TO THE CENTERLINE OF ALL OTHER WALLS. AREAS SHOWN ARE ROUNDED TO THE NEAREST SQUARE FOOT.
  5. GROSS SQUARE FOOTAGE IS EQUAL TO ALL FLOOR AREA (INCLUDING ALL OPENINGS IN FLOOR SLABS) MEASURED TO THE OUTER SURFACES OF EXTERIOR WALLS, EXCEPT FOR CORNERS OF CORNERS, MEZZANINES, HALLS, VESTIBULES, STAIRWELLS, SERVICE AND EQUIPMENT ROOMS, PERFORMANCES, VAULTS, AND ENCLOSED PASSAGES.
  6. DIMENSIONS SHOWN ARE ROUNDED TO THE NEAREST INCH.

JOHNSON CONTROLS

AS-BUILT RECORD FLOOR PLAN  
 LABORATORY BUILDING  
 ARCH: RECORD FLOOR PLAN

BLDG 152

OWNER: Los Alamos National Laboratory  
 PROJECT: Los Alamos, New Mexico 87545

DATE: 5/15/96

7556

AB628

FIELD VERIFIED 02-23-96

ENG-C 2223 (sheet 2)  
 Building DPE-152  
 Floor Plan & Elevations  
 April 13, 1945

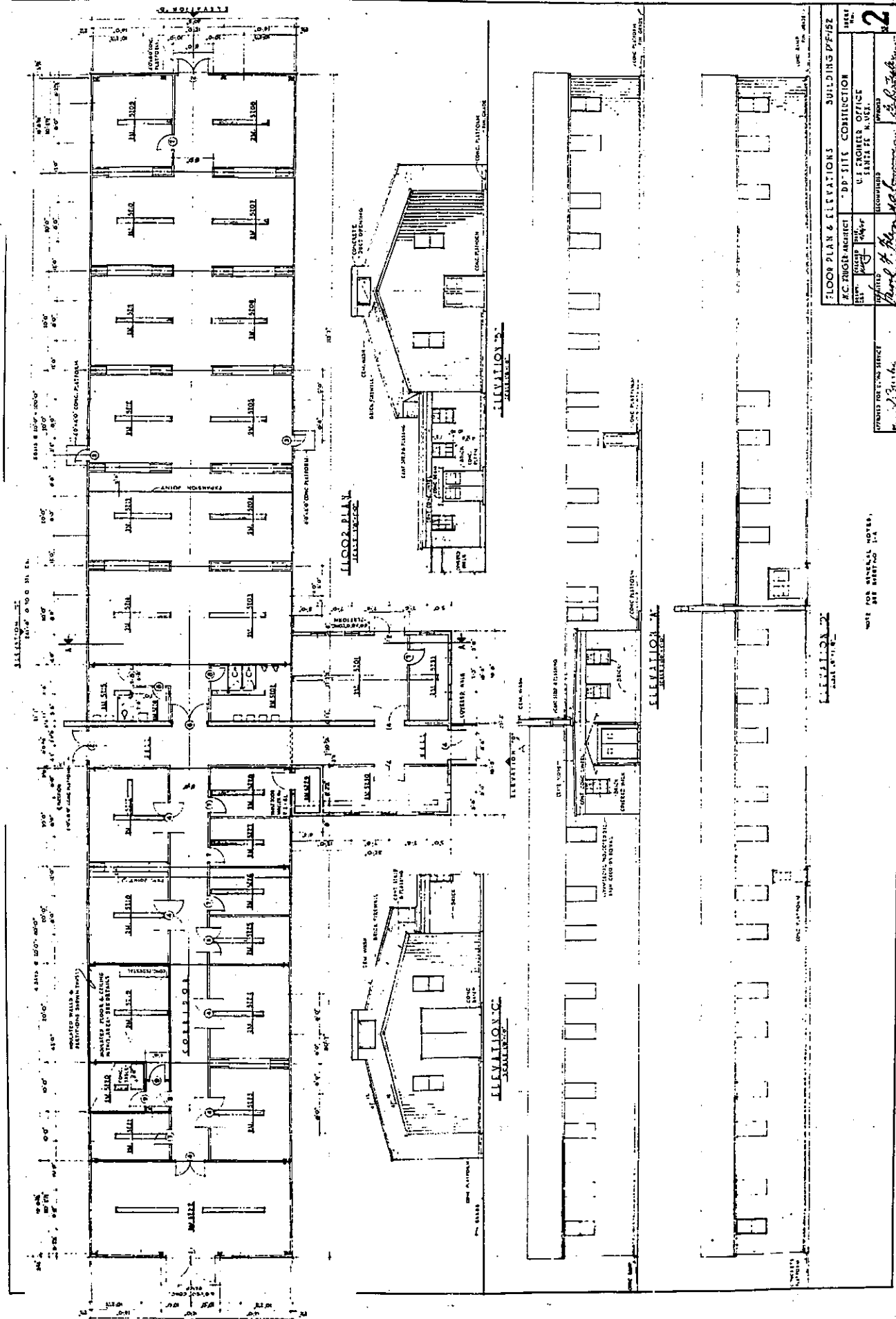

FLOOR PLAN & ELEVATIONS		BUILDING DPE-152	
ARCHITECT	F.C. FRUGIER	CONSTRUCTION	DP-1111
ENGINEER	W.H. HARRIS	OFFICE	U.S. ENGINEER OFFICE
DATE	APRIL 13, 1945	LOCATION	SANITIZ. BLDG.
DESIGNED BY	W.H. HARRIS	PROJECT NO.	2
CHECKED BY	F.C. FRUGIER	SCALE	AS SHOWN

NOT FOR GENERAL NOTES,  
 SEE DRAWINGS 1-4

L.A.S.L. DWG. NO. ENG-C 2223 2-22-70



### TA-21-166

**Original Function:** Equipment Building  
**Current Function:** Equipment Building  
**Historical Significance:** Supported initiator research and development, high-temperature chemistry research, and tritium research.

**Date Constructed:** 1945  
**Associated Theme:** Initiator Development, Nuclear Propulsion, Tritium R&D (Support)  
**Eligible?:** Yes – “A”  
(due to its association with TA-21-152)

### **Description:**

TA-21-166 is a two-story equipment building that is attached to TA-21-152 and serves the south wing of that building. Building TA-21-166 is 1,102 ft<sup>2</sup> in size and was built of gypsum board siding and concrete masonry units. The first floor contains a pipe tunnel, a pit, an opening in the foundation for mechanical work, and an open area. A wooden staircase, situated along the north elevation, continues up along the west wall to the second story of the building. The foundation is concrete slab and beam.





ENG-C 2254  
 Building DPB-166 (S2-A)  
 Plans, Elevations, & Details  
 April 19, 1945

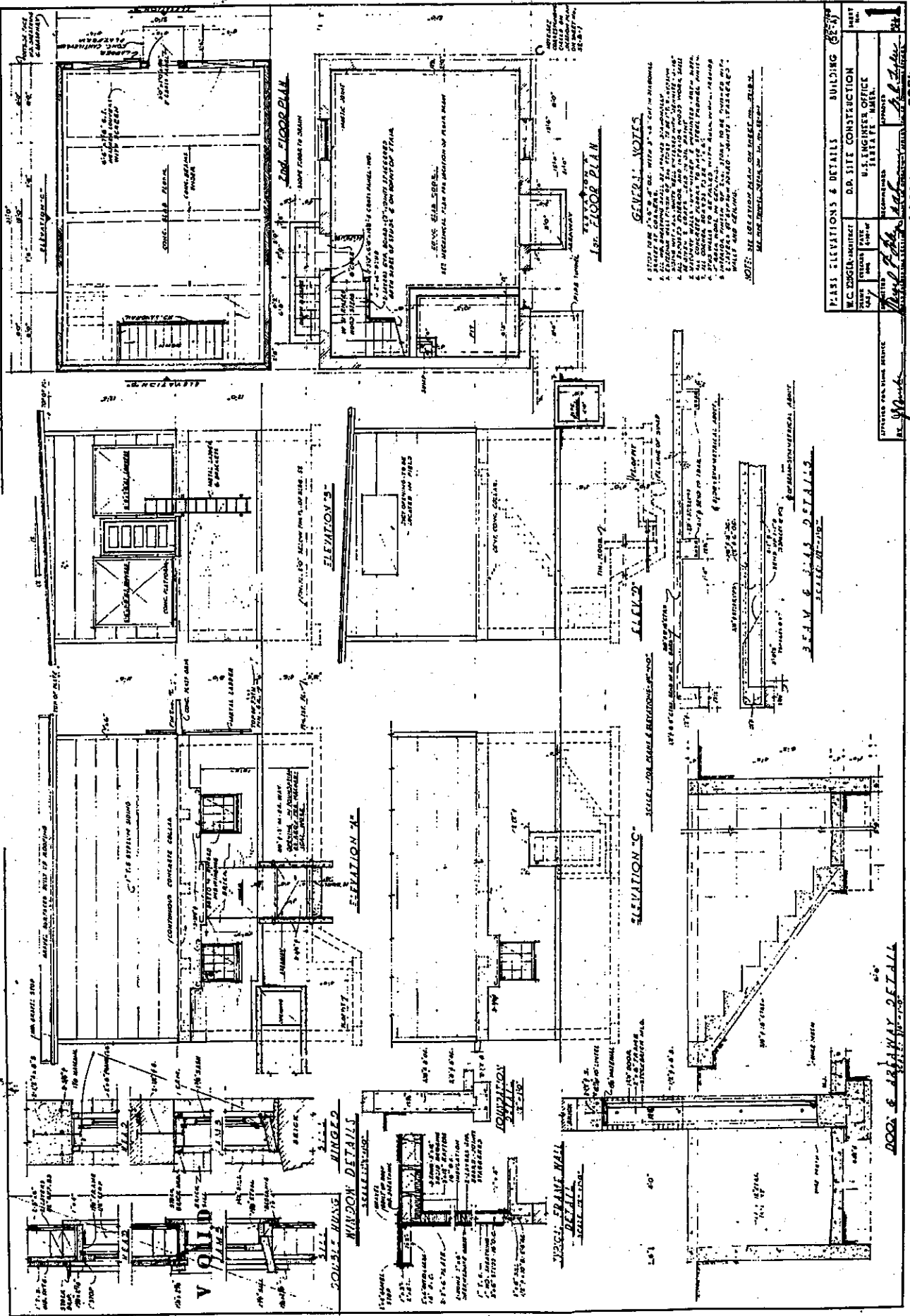

<b>PLANS, ELEVATIONS &amp; DETAILS</b> <b>BUILDING</b> <b>DPB-166 (S2-A)</b>	
<b>ENGINEER</b> DR. SITE CONSTRUCTION U.S. ENGINEER OFFICE 1111 R STREET, N.W. WASHINGTON, D.C.	<b>DATE</b> APRIL 19, 1945
<b>SCALE</b> AS SHOWN	<b>PROJECT NO.</b> 2254
<b>DESIGNED BY</b> [Signature]	<b>CHECKED BY</b> [Signature]
<b>DATE</b> APRIL 19, 1945	<b>SCALE</b> AS SHOWN



### TA-21-167

**Original Function:** Equipment Building  
**Current Function:** Equipment Building  
**Historical Significance:** Supported initiator research and development, high-temperature chemistry research, and tritium research.

**Date Constructed:** 1945  
**Associated Theme:** Initiator Development, Nuclear Propulsion, Tritium R&D (Support)  
**Eligible?:** Yes – “A”  
(due to its association with TA-21-152)

### **Description:**

TA-21-167 is almost identical to TA-21-166: it is a two-story equipment building connected to TA-21-152. TA-21-167, also 1,102 ft<sup>2</sup> in size, provides HVAC support for the north wing of the main laboratory building. The equipment building's second-story exterior walls are made of gypsum board siding, and the interior walls are constructed of concrete masonry units covered with two layers of gypsum board. The foundation is concrete slab and beams. The first floor of the building contains a pit in the northwest corner, and a wooden staircase is situated along the west interior wall.

ENG-R 2962  
 Equipment Building, DPE-167  
 First & Second Floor Plans  
 September 19, 1983

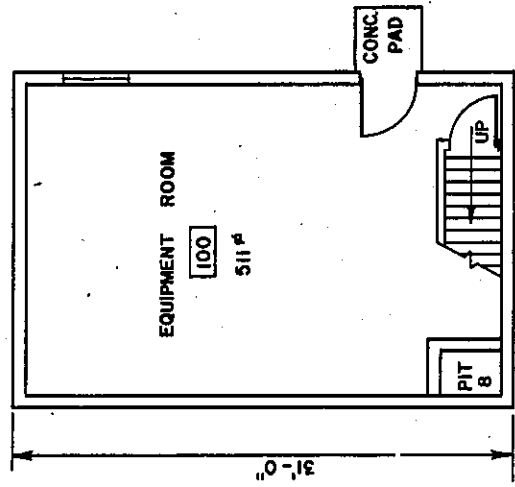
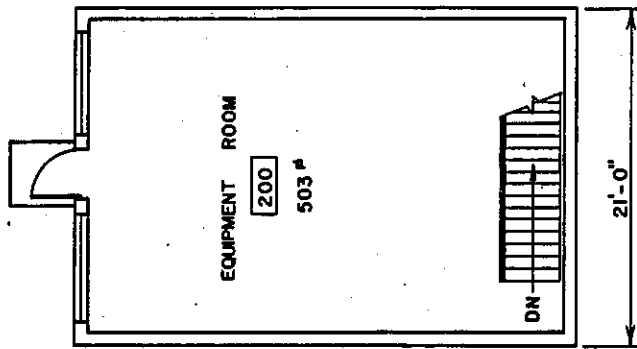

TOTAL 1102



REV.	DATE	REVISION	BY	CHK. APP.
2	2-6-86	REVISED TO STATUS OF 2-6-84	HAN	DP
UNIVERSITY OF CALIFORNIA <b>Los Alamos</b> Los Alamos National Laboratory Los Alamos, New Mexico 87545				
FACILITIES ENGINEERING DIVISION				
EQUIPMENT BUILDING				
FIRST & SECOND FLOOR PLANS				
BLDG. DP-167				
REC. CLASSIFICATION				
CLASS.	DATE	REVISOR	DATE	REVISION
41	9-12-84	DP	9-12-84	1
SUBMITTED BY: <i>Donna Piro</i>				
RECOMMENDED BY: <i>R.H. Rockwell</i>				
DATE	BY	DATE	BY	DATE
9-19-83	<i>E. Teyello</i>	9-19-83	<i>DP</i>	9-19-83
CHECKED	DRAWN	MARKED	BY	DATE
<i>DP</i>	<i>DP</i>	<i>DP</i>	<i>DP</i>	9-19-83
DRAWING NO. ENG-R2962				

3/25/84



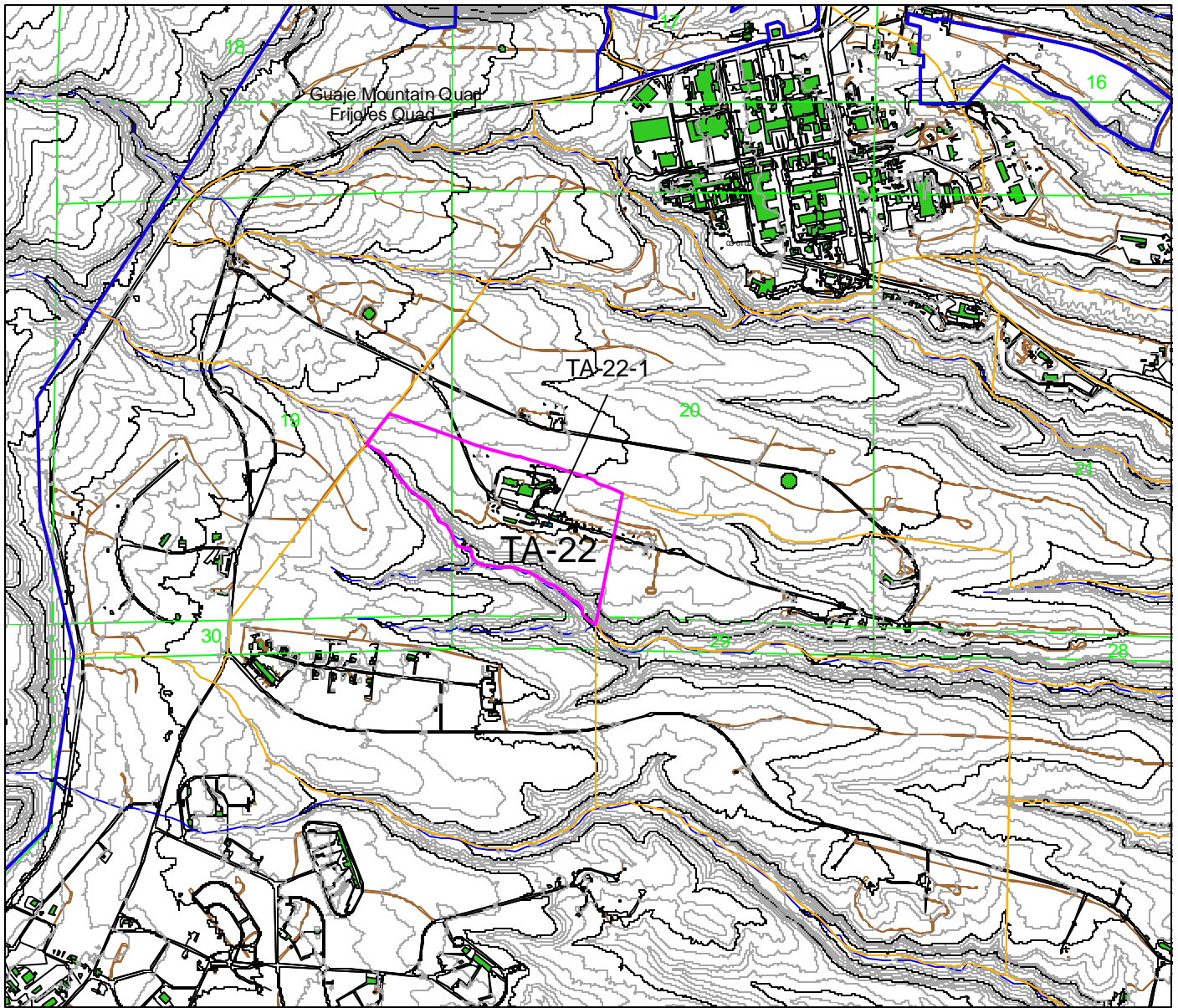

# Los Alamos National Laboratory

Cultural Resources Management Team  
RRES-ECO Ecology Group

1:24000

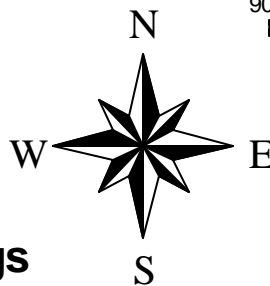
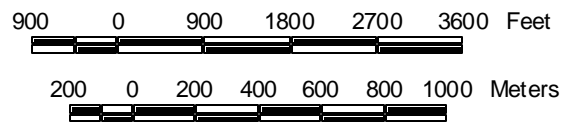

## Manhattan Project Buildings

TA-22

- Manhattan Project Buildings
- Los Alamos National Laboratory
- Tech Area 22
- Tech Areas
- 20 Foot Contours
- 100 Foot Contours
- Drainage
- Township, Section, Range
- USGS 7.5 Minute Quad
- Roads
- Road/dirt
- Park/pave
- Park/dirt
- Buildings/Structures

Map 24

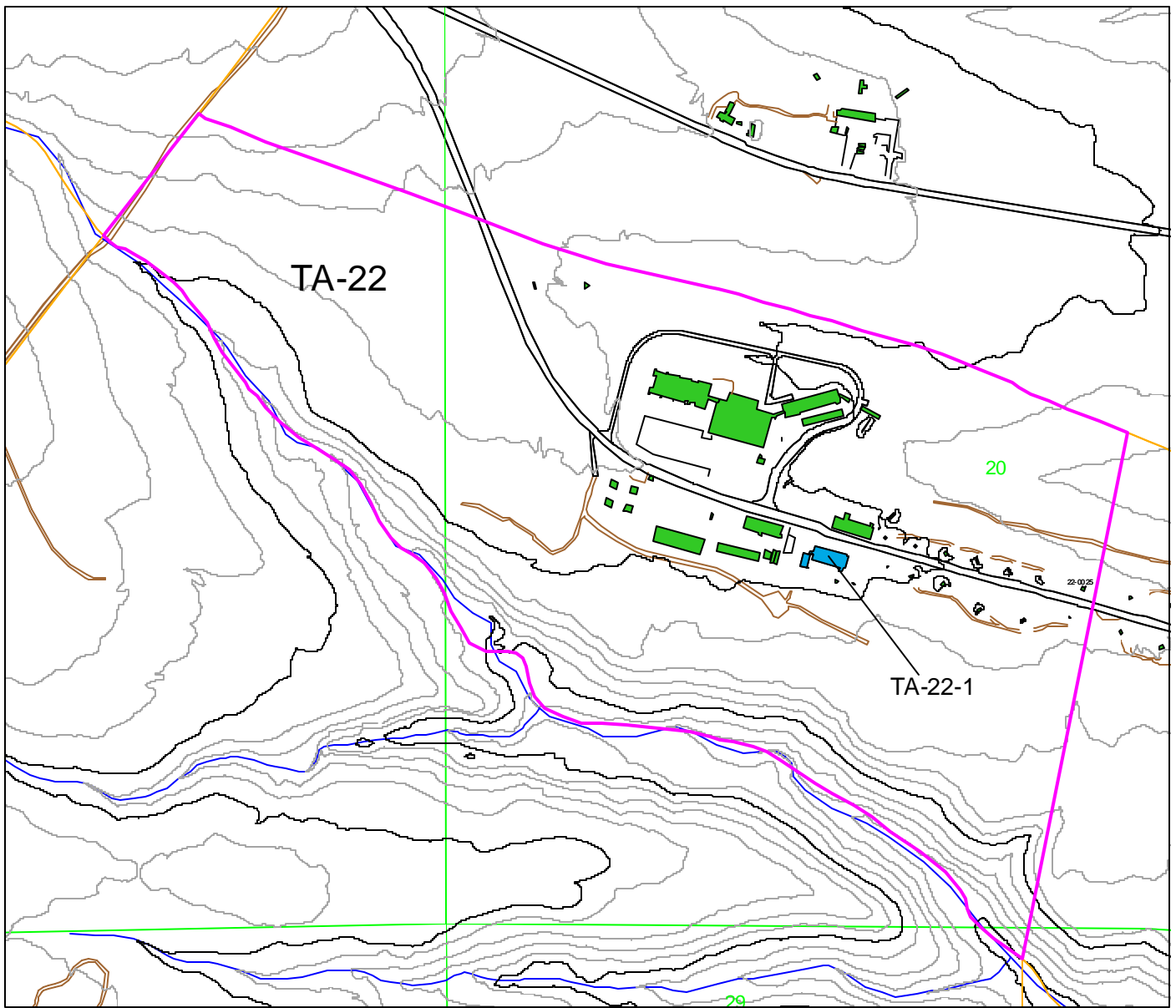

Frijoles Quad

# Los Alamos National Laboratory

*Cultural Resources Management Team  
RRES-ECO Ecology Group*

1:6000

200 0 200 400 600 800 Feet

70 0 70 140 210 Meters

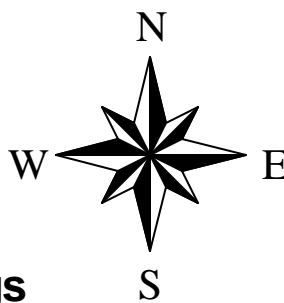

## Manhattan Project Buildings

## TA-22 Closeup

- Manhattan Project Buildings
- Los Alamos National Laboratory
- Tech Area 22
- Tech Areas
- 20 Foot Contours
- 100 Foot Contours
- Drainage
- Township, Section, Range
- USGS 7.5 Minute Quad
- Roads
- Road/dirt
- Park/pave
- Park/dirt
- Buildings/Structures

Map 25





### TA-22-1

**Original Function:** Assembly and Loading Building

**Current Function:** Vacant

**Historical Significance:** Explosive components for the “Fat Man” bomb were tested and assembled in TA-22-1.

**Date Constructed:** 1945

**Associated Theme:** Implosion

**Eligible?:** Yes – “A”

### **Description:**

TA-22-1 is a true quonset hut, often referred to as a Pacific-style hutment facility. It sits on a concrete foundation, which is visible at the stem wall level just below the metal siding. The building is covered with heavy gauge, corrugated siding arching over the frame. The siding has several coats of aluminized silver paint. Numerous steel casement windows line each side of the building. Due to the arch shape of the building, the windows rest at a slight angle. The windows are three-over-three, awning type windows. The east and west ends of the building have wood-frame additions, which serve as entrances to the building. The additions are covered with corrugated metal siding and have flat roofs.

During World War II, Los Alamos scientists assembled and tested explosive components for the world’s second atomic implosion bomb in this building. The “Fat Man” bomb was detonated over Nagasaki, Japan, on August 9, 1945.

NO.	DATE	REVISIONS	BY	CHKD	GRP. ENG
					LDR D.G.

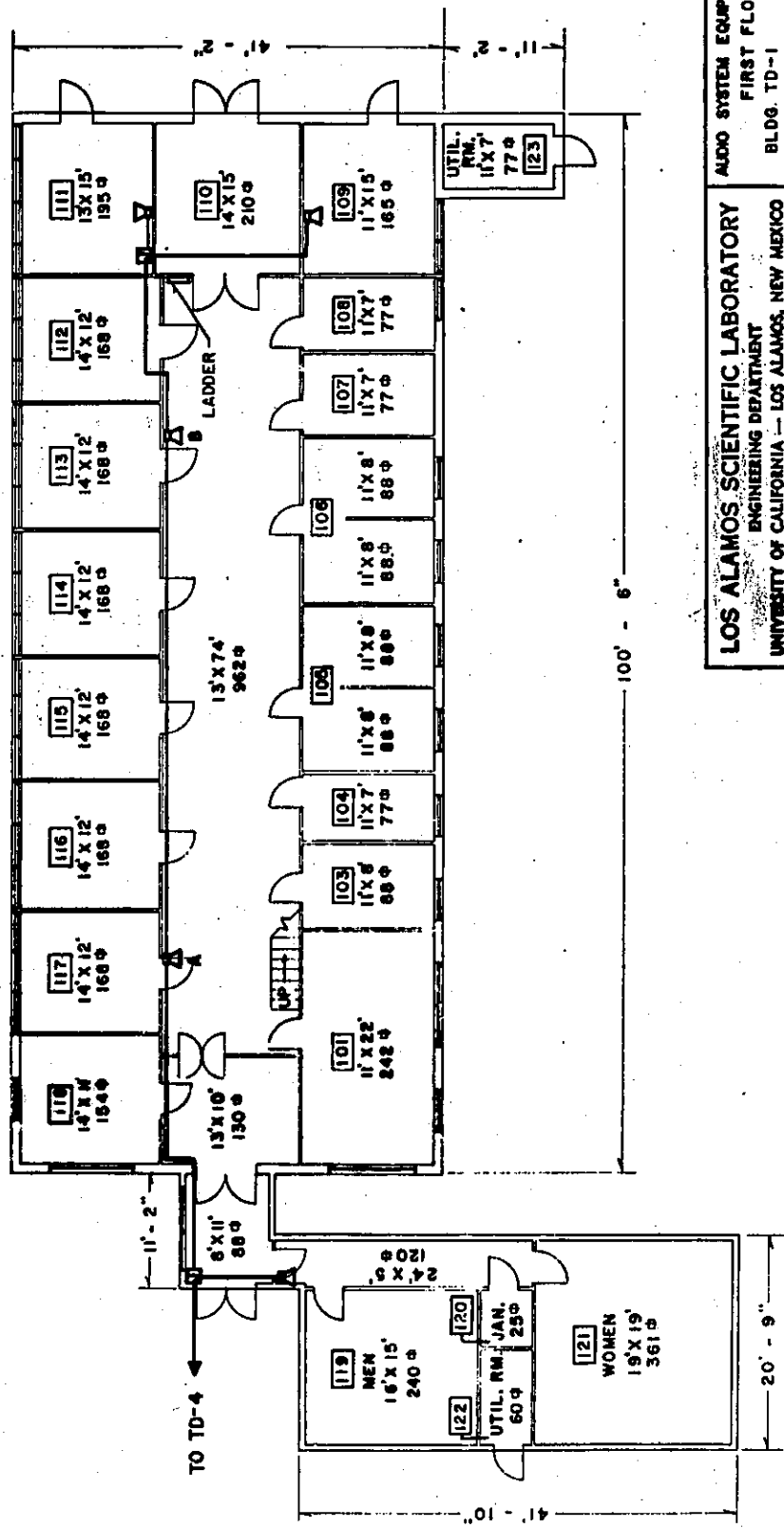

MEZZANINE TOTAL SQ. FT. 2238  
 FIRST FLOOR TOTAL SQ. FT. 4708  
 TOTAL SQ. FT. 6946

**LOS ALAMOS SCIENTIFIC LABORATORY**  
 ENGINEERING DEPARTMENT  
 UNIVERSITY OF CALIFORNIA — LOS ALAMOS, NEW MEXICO

BLDG. TD-1 TA-22

**AUDIO SYSTEM EQUIPMENT LOCATION**  
**FIRST FLOOR PLAN**

DATE: 9/7/67  
 SCALE: 3/8" = 1'-0"

DESIGNER: LEMON  
 PROJ. ENG. [Signature]  
 SHEET: 1 OF 1  
 ENG. R. 4206

APPROVALS:  
 ENG. GROUP: [Signature]  
 DIVISION: [Signature]  
 ENG. DEPT. OFFICE: [Signature]

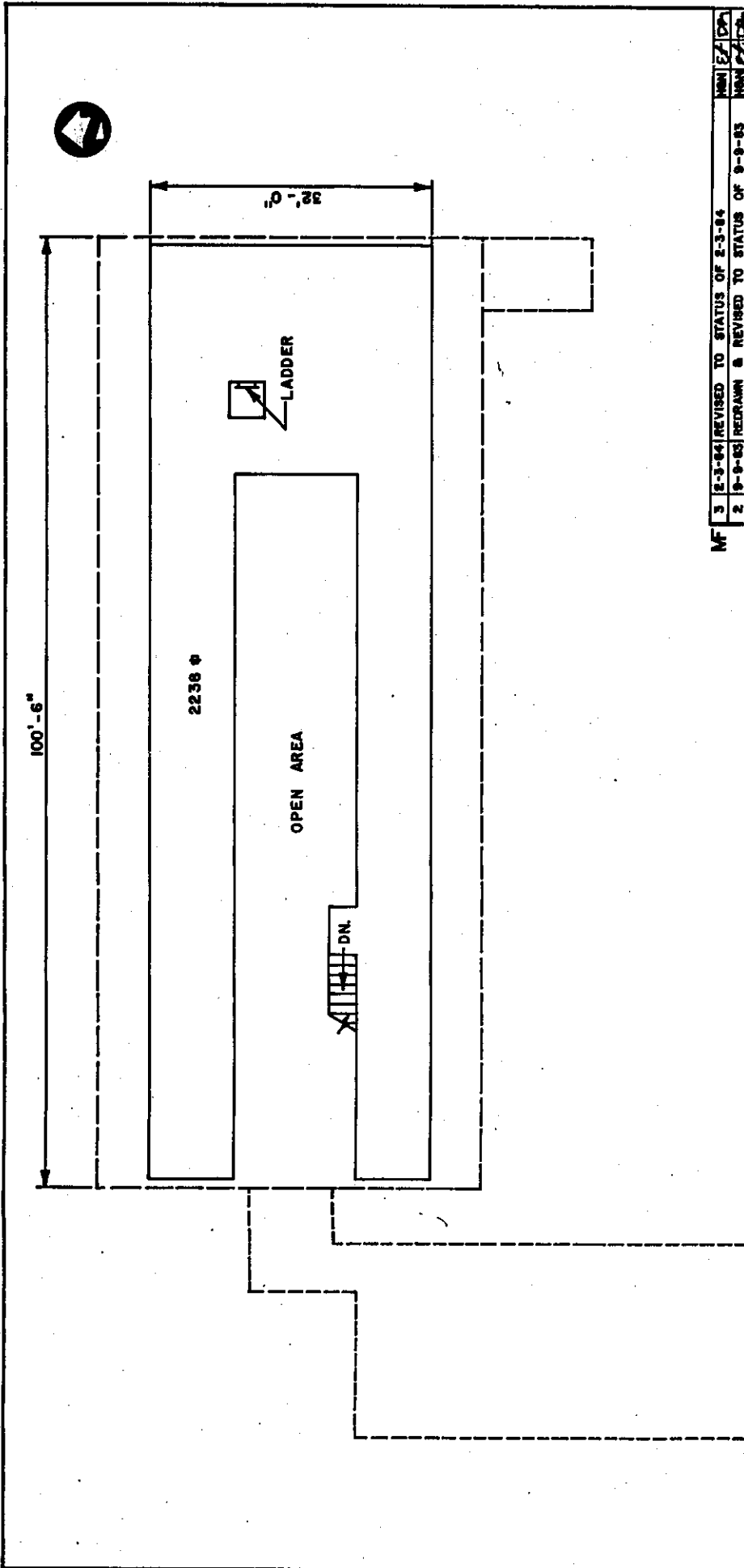

GRAPHIC SCALE

MEZZANINE TOTAL SQ. FT. 2238

3	2-3-84	REVISED TO STATUS OF 2-3-84	MM	DP
2	9-9-83	REDRAWN & REVISED TO STATUS OF 9-9-83	MM	DP
REV.	DATE	REVISION	BY	CHK. DATE
UNIVERSITY OF CALIFORNIA				
<b>Los Alamos</b>				
Los Alamos National Laboratory Los Alamos, New Mexico 87545				
FACILITIES ENGINEERING DIVISION				
LOADING BUILDING				
MEZZANINE FLOOR PLAN				
BLDG. ID-1				
REV. CLASS. 4				
REVISED <i>Revised</i>				
DATE 5-12-74				
DATE 9-9-83				
DATE 7A-22				
DESIGNED	BY	CHECKED	DATE	BY
<i>W. J. Sam</i>	<i>W. J. Sam</i>	<i>W. J. Sam</i>	<i>9-9-83</i>	<i>W. J. Sam</i>
PROJECT NO.	SHEET NO.	DRAWING NO.		
<i>2238</i>	<i>2</i> OF <i>2</i>	<i>ENG-R2968</i>		

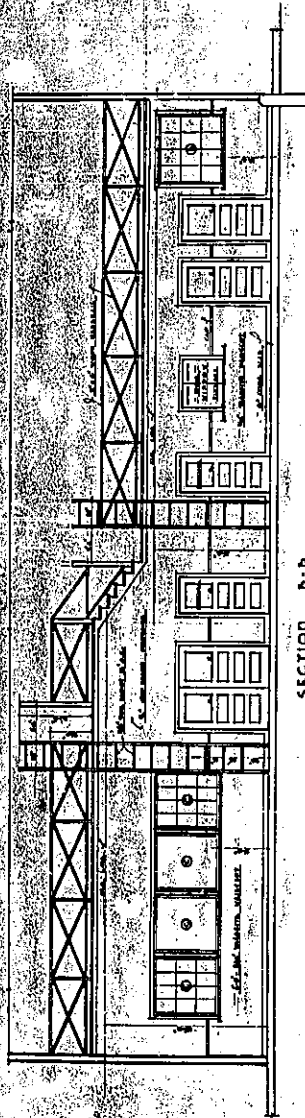

SECTION P.P.  
SHOWING BALCONY DETAILS  
SCALE 1/8"

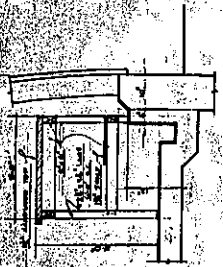

TYPICAL SECT.  
WINDOW BENCH  
SCALE 1/4"

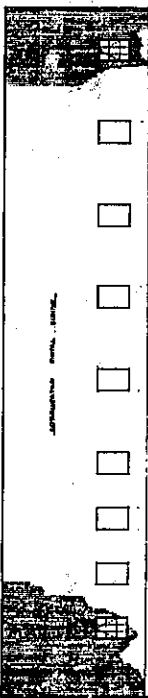

ELEVATION 11  
SCALE 1/8"

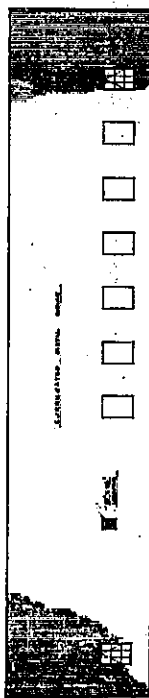

ELEVATION 12  
SCALE 1/8"

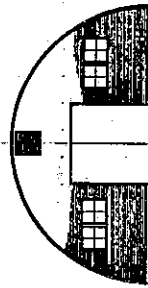

ELEVATION 13  
SCALE 1/8"

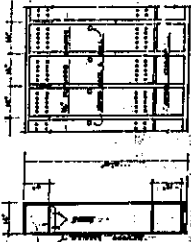

ELEVATION  
LOCKER DETAILS  
SCALE 1/8"

GENERAL NOTES

1. PROVIDE CURBS WITH APPROVED CURB AND GUTTER SYSTEMS.
2. ALL EXTERIOR WALLS TO BE FINISHED WITH BRICK OR CONCRETE BLOCK.
3. ALL EXTERIOR WALLS TO BE FINISHED WITH BRICK OR CONCRETE BLOCK.
4. ALL EXTERIOR WALLS TO BE FINISHED WITH BRICK OR CONCRETE BLOCK.
5. ALL EXTERIOR WALLS TO BE FINISHED WITH BRICK OR CONCRETE BLOCK.
6. ALL EXTERIOR WALLS TO BE FINISHED WITH BRICK OR CONCRETE BLOCK.
7. ALL EXTERIOR WALLS TO BE FINISHED WITH BRICK OR CONCRETE BLOCK.

PROJECT NO.	100-100000-0000
DATE	05/10/2005
SCALE	AS SHOWN
DESIGNED BY	...
CHECKED BY	...
APPROVED BY	...
DATE	05/10/2005

DATE PLOTTED: 05/10/2005



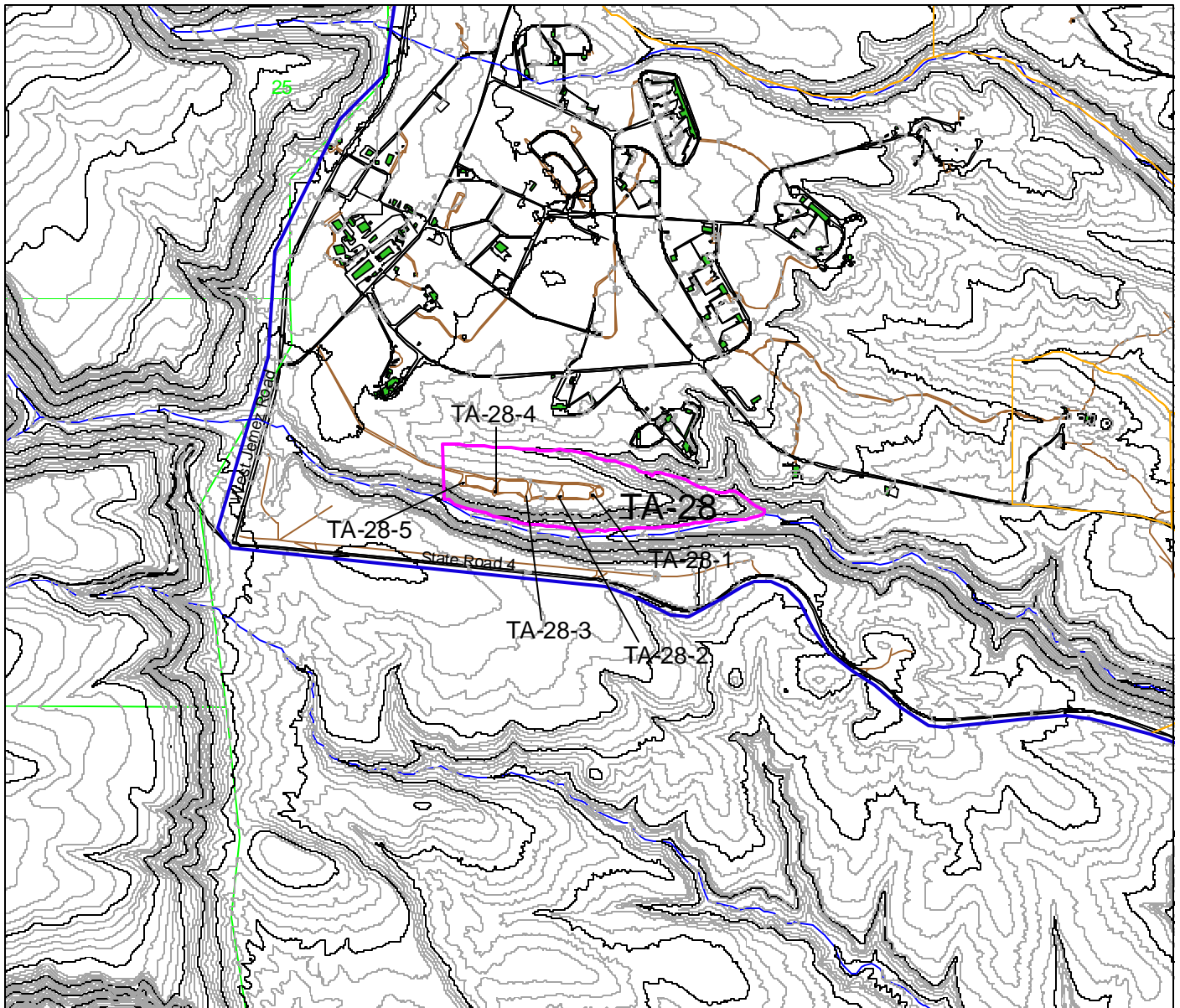

**Los Alamos National Laboratory**  
 Cultural Resources Management Team  
 RRES-ECO Ecology Group

1:24000

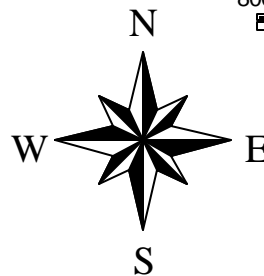
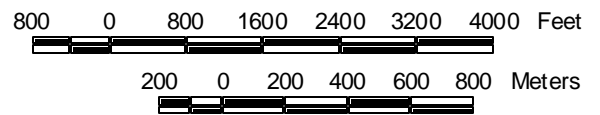

**Manhattan Project Buildings**

**TA-28**

- Manhattan Project Buildings
- Los Alamos National Laboratory
- Tech Area 28
- Tech Areas
- 20 Foot Contours
- 100 Foot Contours
- Drainage
- Township, Section, Range
- USGS 7.5 Minute Quad
- Roads
- Road/dirt
- Park/pave
- Park/dirt
- Buildings/Structures

Map 26



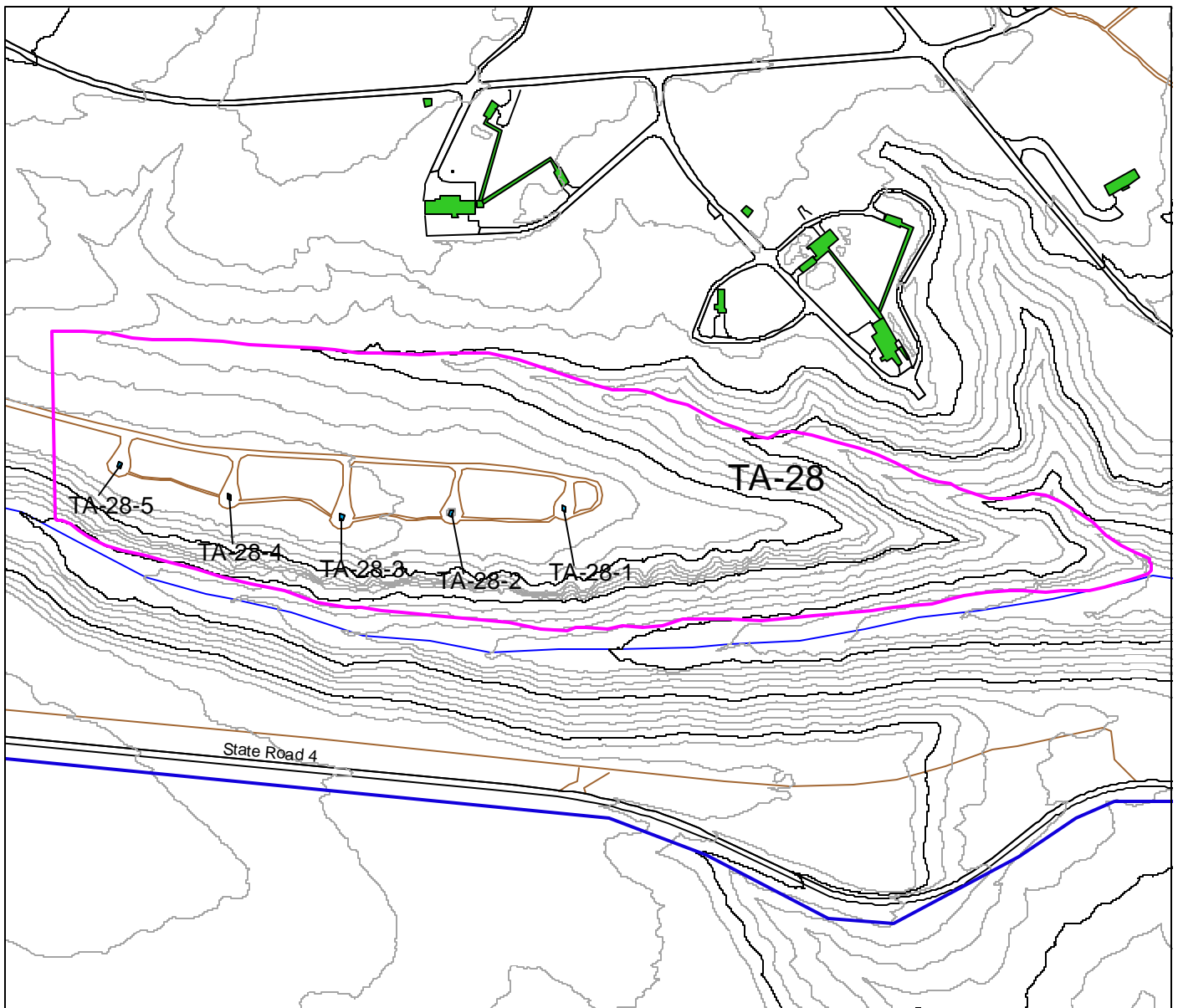

Frijoles Quad

# Los Alamos National Laboratory

Cultural Resources Management Team  
RRES-ECO Ecology Group

1:7000

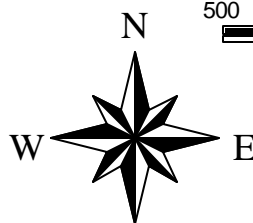
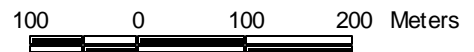

## Manhattan Project Buildings

## TA-28 Closeup

- Manhattan Project Buildings
- Los Alamos National Laboratory
- Tech Area 28
- Tech Areas
- 20 Foot Contours
- 100 Foot Contours
- Drainage
- Township, Section, Range
- USGS 7.5 Minute Quad
- Roads
- Road/dirt
- Park/pave
- Park/dirt
- Buildings/Structures

Map 27



TA-28-1

TA-28-1, -2, -3, -4 and -5

**Original Function:** Magazines

**Current Function:** Same (vacant?)

**Historical Significance:** Explosives storage support for high explosives operations.

**Date Constructed:** 1944?

**Associated Theme:** High Explosives

**Eligible?:** Yes – “A”

(although only one example of these five identical properties would need to be documented)

**Description:**

These five magazine structures are similar in purpose and construction to each other. Each facility is approximately 12 ft by 24 ft in size. The foundation slab and wall structure for each magazine is cast-in-place concrete. The concrete walls extend up to about 6 ft and act as a retaining wall against the earth berm adjacent to each building. The upper 2 ft portion of each structure is wood frame with asbestos shingles. Each roof is wood frame with a low slope asphalt granular roofing material. Most of the entry doors are on the south elevation. The doors are hollow metal in metal frames. Earth berms surround the structures on three sides and are covered with vegetation.

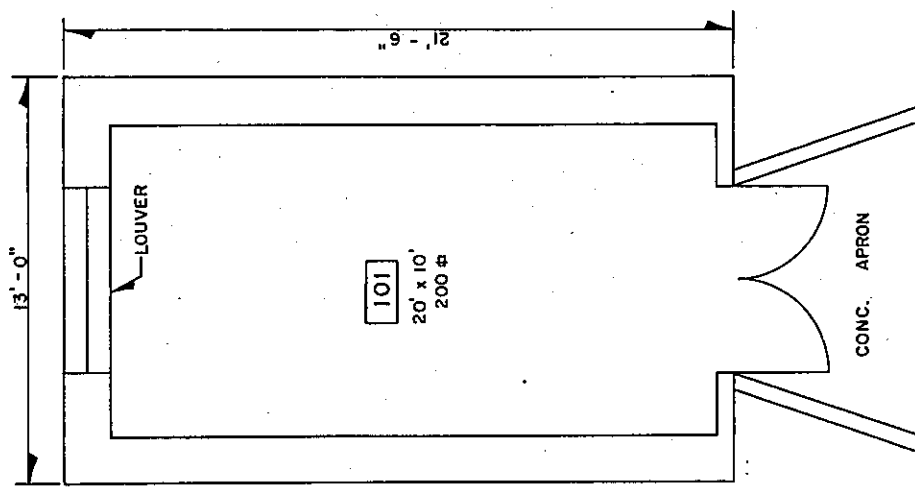

REV.	DATE	REVISION	BY	CHKD.	APP'D.
2	2-2-84	REVISED TO STATUS OF 2-2-84	HBN	DP	
1	9-19-83	REVISED TO STATUS OF 9-19-83	HBN	DP	

UNIVERSITY OF CALIFORNIA  
**Los Alamos**  
 Los Alamos National Laboratory  
 Los Alamos, New Mexico 87545

FACILITIES ENGINEERING DIVISION

MAGAZINE

FLOOR PLAN

BLDG. MAA-1 TA-28

SEC. CLASSIFICATION

CLASS. *CC*

REVIEWED *Blair*

DATE 3-12-82

APPROVED *Ruth Ricketts*

RECOMMENDED *Dennis Pigo*

SUBMITTED *E. Traylor*

DRAWN **WIMBERLEY**

CHECKED *Wimbles*

DATE 8-18-64

SHEET NO. 1 OF 1

DRAWING NO. ENG-R3012

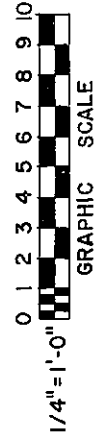
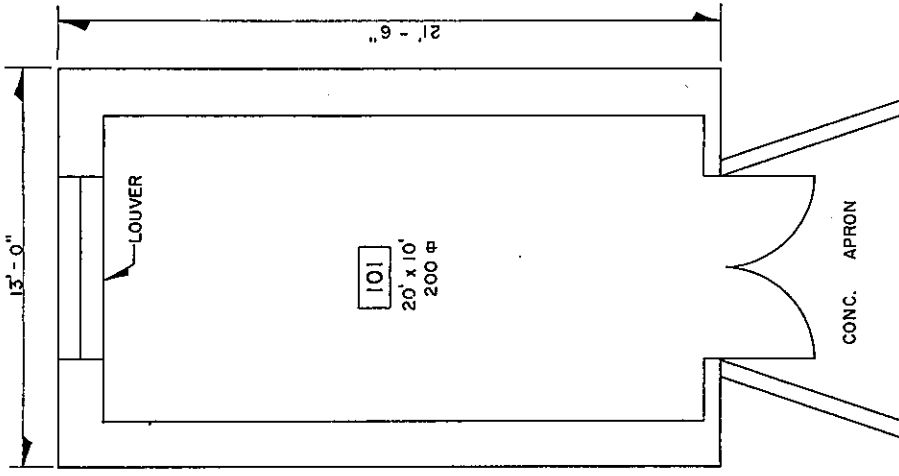

2	2-3-84	REVISED TO STATUS OF 2-3-84	HN	HN
1	9-20-83	REVISED TO STATUS OF 9-20-83	HN	HN
REV.	DATE	REVISION	BY	CHK. APP.

UNIVERSITY OF CALIFORNIA  
**Los Alamos** Los Alamos National Laboratory  
 Los Alamos, New Mexico 87545

**FACILITIES ENGINEERING DIVISION**

**MAGAZINE**

**FLOOR PLAN**

BLDG. MAA-2 TA-28

SUBMITTED: *W. Kimberley* RECOMMENDED: *D. Kimberley* DATE: *3-12-84*

DRAWN: WIMBERLEY DATE: 8-18-64 SHEET NO. *1* OF *1* DRAWING NO. *ENG-R3013*

CHECKED: *W. Kimberley*

TOTAL SQ. FT. 200

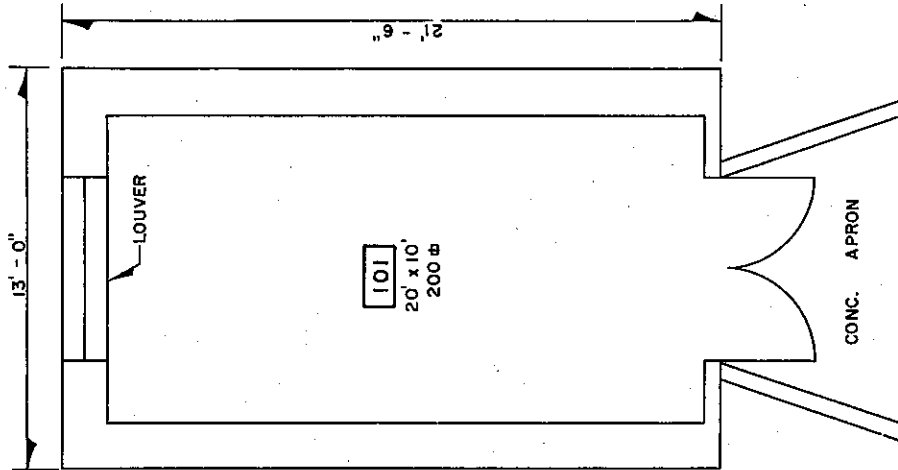

TOTAL SQ. FT. 200

REV.	DATE	REVISION	HBN	BY	CHK. APP.
2	2-1-84	REVISED TO STATUS OF 2-1-84	HBN	CD	CD
1	9-20-83	REVISED TO STATUS OF 9-20-83	HBN	CD	CD

UNIVERSITY OF CALIFORNIA  
**Los Alamos**  
 Los Alamos National Laboratory  
 Los Alamos, New Mexico 87545

FACILITIES ENGINEERING DIVISION

REC. CLASSIFICATION  
 CLAS. 4  
 REVIEWER *Sh...*  
 DATE 3-12-84

BLDG. MAA-3  
 TA-28

SUBMITTED *E. Traylor*  
 RECOMMENDED *Donna Perry*  
 APPROVED *Rich. Roberts*

DRAWN WIMBERLEY  
 CHECKED *Frank HEN*  
 DATE 8-19-64  
 SHEET NO. 1 OF 1  
 DRAWING NO. ENG-R3014

MF



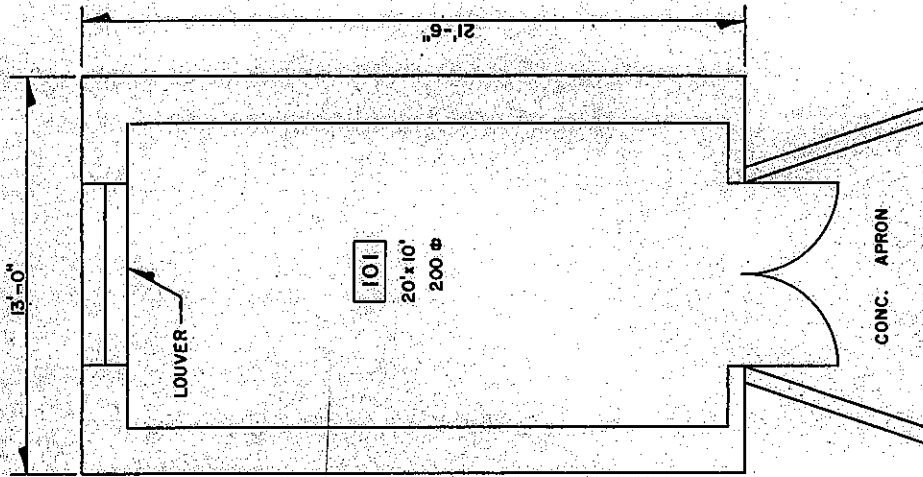

TOTAL SQ. FT. 200

REV.	DATE	REVISION	BY	CHKD.	APP.
1	6-8-64	REVISED TO STATUS OF 6-8-64		HBN	JL
UNIVERSITY OF CALIFORNIA <b>Los Alamos</b> Los Alamos National Laboratory Los Alamos, New Mexico 87545					
FACILITIES ENGINEERING DIVISION					
MAGAZINE					
FLOOR PLAN					
BLDG. MAA-4					
TA-28					
REC'D. BY: <i>Don</i>					
DATE: 8-19-64					
SHEET NO. 1 OF 1					
APPROVED: <i>Carl E. ...</i>					
DRAWING NO. ENG-R3015					

MF



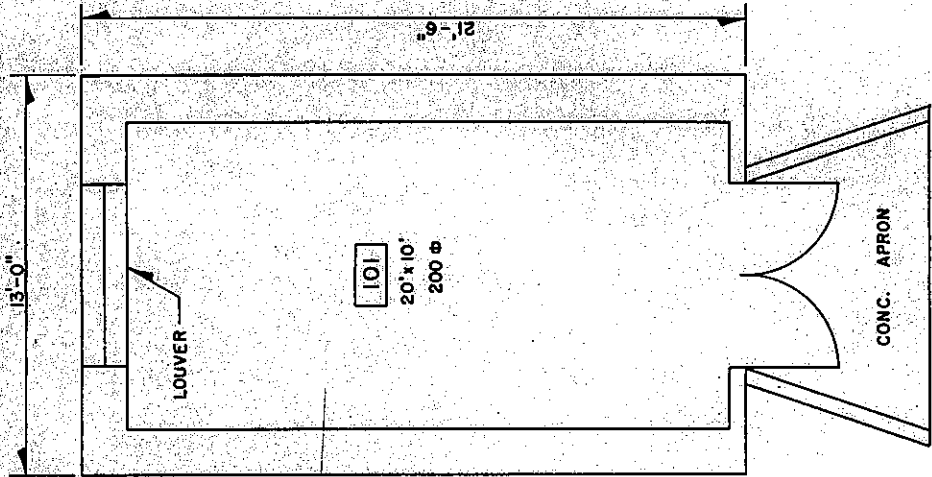

REV.	DATE	REVISED TO	STATUS OF	6-8-84	BY	CHK.	APP.
			REVISION				
UNIVERSITY OF CALIFORNIA				Los Alamos National Laboratory Los Alamos, New Mexico 87545			
<b>Los Alamos</b>				FACILITIES ENGINEERING DIVISION			
MAGAZINE				REC. CLASSIFICATION:			
FLOOR PLAN				CLASS. 4			
BLDG. MAA-5				REVIEWER: <i>[Signature]</i>			
SUBMITTED: <i>[Signature]</i>				DATE: 6-1-82			
RECOMMENDED: <i>[Signature]</i>				APPROVED: <i>[Signature]</i>			
DRAWN: WIMBERLEY				DATE: 8-19-64			
CHECKED: <i>[Signature]</i>				SHEET NO. 1 of 1			
				DRAWING NO. ENG-R3016			

TOTAL SQ. FT. 200

**Appendix B—Photographs of Remaining Manhattan Project  
Buildings and Structures  
(Los Alamos County/Privatey Owned)**



Fuller Lodge, Former Los Alamos Ranch School and Manhattan Project Dining Room and Residence (built 1928), Direction Southwest



Fuller Lodge, Direction Southeast





Los Alamos Historical Museum Building, Former Los Alamos Ranch School and Manhattan Project Guest Cottage (built circa 1918), Direction Northeast



The Baker House, Former Los Alamos Ranch School Chief Mechanic's Residence (built 1925), Also Manhattan Project Staff Residence, Direction Northeast





Example of Bathtub Row House, Former Los Alamos Ranch School and Manhattan Project Staff Residence (built circa 1920s), Direction Northwest



The Red Cross Building, Former Los Alamos Ranch School Power House and Manhattan Project Residence (built early 1930s), Direction Northwest





The Hill Diner, Possible Former Manhattan Project Veterinary Hospital, T-323 (built early 1940s, extensively remodeled?), Direction Northeast



Unitarian Church, Former Manhattan Project Dormitory, T-102 (built early 1940s), Direction Northeast





Christian Science Building, Former Manhattan Project 20-Men Capacity Dormitory (built early 1940s), Direction Northwest



The Last Sundt Building (2<sup>nd</sup> Phase Flat Roof Quadruplex), Former Manhattan Project Housing (built circa 1943), Direction North





Performing Arts Building, Former Manhattan Project “East Cafeteria” then “Rec Hall” (built early 1940s), Direction Southeast



Performing Arts Building, Direction North

---

## Notes

<sup>1</sup> Hal Rothman, *On Rims and Ridges, The Los Alamos Area Since 1880* (Lincoln, Nebraska: University of Nebraska Press, 1992).

<sup>2</sup> Los Alamos National Laboratory, "Los Alamos National Laboratory: A Proud Past, An Exciting Future (Special Issue)," *Dateline: Los Alamos*, 1995.

<sup>3</sup> Rothman, *On Rims and Ridges, The Los Alamos Area Since 1880*.

<sup>4</sup> Ibid.

<sup>5</sup> Los Alamos National Laboratory, "Los Alamos National Laboratory: A Proud Past, An Exciting Future (Special Issue)," Richard Rhodes, *The Making of the Atomic Bomb* (New York: Simon and Schuster, 1986).

<sup>6</sup> Los Alamos National Laboratory, "Los Alamos National Laboratory: A Proud Past, An Exciting Future (Special Issue)," Los Alamos National Laboratory, *Los Alamos: Beginning of an Era, 1943-1945* (Los Alamos, New Mexico: Reprinted by the Los Alamos Historical Society, 1993).

<sup>7</sup> Los Alamos National Laboratory, "Los Alamos National Laboratory: A Proud Past, An Exciting Future (Special Issue)."

<sup>8</sup> Rothman, *On Rims and Ridges, The Los Alamos Area Since 1880*.

<sup>9</sup> Los Alamos National Laboratory, "Los Alamos National Laboratory: A Proud Past, An Exciting Future (Special Issue)" 8.

<sup>10</sup> F. G. Gosling, *The Manhattan Project: Making the Atomic Bomb* (Washington, DC: U.S. Department of Energy, 2001), DOE/MA-0002, David Hawkins, Edith C. Truslow, and Ralph Carlisle Smith, *Project Y: The Los Alamos Story*, *The History of Modern Physics, 1800-1950*, vol. II (Tomash Publishers and the American Institute of Physics, 1988).

<sup>11</sup> Fern Lyon and Jacob Evans, ed., *Los Alamos: The First Forty Years* (Los Alamos, New Mexico: Los Alamos Historical Society, 1984), 21.

<sup>12</sup> Hawkins, *Project Y: The Los Alamos Story*.

<sup>13</sup> Ibid, Edith C. Truslow, *Manhattan District History: Nonscientific Aspects of Los Alamos Project Y, 1942 through 1946* (Los Alamos, New Mexico: The Los Alamos Historical Society, 1991).

<sup>14</sup> Gosling, *The Manhattan Project: Making the Atomic Bomb* and Hawkins, *Project Y: The Los Alamos Story*.

<sup>15</sup> Gosling, *The Manhattan Project: Making the Atomic Bomb*.

<sup>16</sup> Los Alamos National Laboratory, *Los Alamos: Beginning of an Era, 1943-1945*.

<sup>17</sup> Los Alamos National Laboratory, "Los Alamos National Laboratory: A Proud Past, An Exciting Future (Special Issue)."

<sup>18</sup> Lillian Hoddeson, Paul W. Henriksen, Roger A. Meade, and Catherine Westfall, *Critical Assembly: A Technical History of Los Alamos during the Oppenheimer Years, 1943-1945* (New York and Cambridge: Cambridge University Press, 1998).

- 
- <sup>19</sup> Hawkins, *Project Y: The Los Alamos Story*.
- <sup>20</sup> Los Alamos National Laboratory, *Los Alamos: Beginning of an Era, 1943-1945*.
- <sup>21</sup> Hoddesson, *Critical Assembly: A Technical History of Los Alamos during the Oppenheimer Years, 1943-1945*.
- <sup>22</sup> Los Alamos National Laboratory, *Los Alamos: Beginning of an Era, 1943-1945*.
- <sup>23</sup> Hoddesson, *Critical Assembly: A Technical History of Los Alamos during the Oppenheimer Years, 1943-1945*, 3.
- <sup>24</sup> Ibid. and Rhodes, *The Making of the Atomic Bomb*.
- <sup>25</sup> Los Alamos National Laboratory, "Los Alamos National Laboratory: A Proud Past, An Exciting Future (Special Issue)."
- <sup>26</sup> Hawkins, *Project Y: The Los Alamos Story*, 126.
- <sup>27</sup> Hoddesson, *Critical Assembly: A Technical History of Los Alamos during the Oppenheimer Years, 1943-1945*.
- <sup>28</sup> Hawkins, *Project Y: The Los Alamos Story*.
- <sup>29</sup> Ibid. and Hoddesson, *Critical Assembly: A Technical History of Los Alamos during the Oppenheimer Years, 1943-1945*.
- <sup>30</sup> Hoddesson, *Critical Assembly: A Technical History of Los Alamos during the Oppenheimer Years, 1943-1945*.
- <sup>31</sup> Ibid.
- <sup>32</sup> Ibid.
- <sup>33</sup> Ibid.
- <sup>34</sup> Los Alamos National Laboratory, "Los Alamos National Laboratory: A Proud Past, An Exciting Future (Special Issue)."
- <sup>35</sup> Ibid., 11.
- <sup>36</sup> Gosling, *The Manhattan Project: Making the Atomic Bomb*.
- <sup>37</sup> Ibid.
- <sup>38</sup> Ibid., Los Alamos National Laboratory Archives, Operation Crossroads, Test Able information (A-84-019).
- <sup>39</sup> Ibid.
- <sup>40</sup> Some information from Ibid. and Los Alamos National Laboratory, "Los Alamos National Laboratory: A Proud Past, An Exciting Future (Special Issue)."
- <sup>41</sup> Los Alamos National Laboratory, "Los Alamos National Laboratory: A Proud Past, An Exciting Future (Special Issue)."
- <sup>42</sup> Hoddesson, *Critical Assembly: A Technical History of Los Alamos during the Oppenheimer Years, 1943-1945*, 9, 10.

---

<sup>43</sup> Hawkins, *Project Y: The Los Alamos Story*, 74.

<sup>44</sup> "Manhattan District History, Book VIII - Los Alamos Project (Y), Volume 1 - General, December 1947," (National Archives Microfilm Publication A1218, Roll 11); Records of the Defense Nuclear Agency; Record Group 374; National Archives at College Park, College Park, MD and Hawkins, *Project Y: The Los Alamos Story*.

<sup>45</sup> Colleen Olinger, "Los Alamos National Laboratory Sites and Facilities Potentially Eligible for Nomination to the National Register of Historic Places, 1986," Attachment to letter from Robert Bradshaw, LANL Deputy Director for Support, to Harold Valencia, Manager, Los Alamos Area Office, U.S. DOE, April 18, 1986. Hawkins, *Project Y: The Los Alamos Story*, 74.

<sup>46</sup> Hawkins, *Project Y: The Los Alamos Story*, 198.

<sup>47</sup> Ibid.

<sup>48</sup> Ibid., 325.

<sup>49</sup> Ibid.

<sup>50</sup> U.S. Department of Energy, *Phase 1: Installation Assessment, Los Alamos National Laboratory, Comprehensive Environmental Assessment and Response Program* (Working Draft). Albuquerque Operations Office, Albuquerque, New Mexico. On file at RRES-ECO, Los Alamos National Laboratory, Los Alamos, New Mexico, 1986

<sup>51</sup> Hawkins, *Project Y: The Los Alamos Story*, Olinger, "Los Alamos National Laboratory Sites and Facilities Potentially Eligible for Nomination to the National Register of Historic Places," "Schematic Plan of Field Work, ca.1944," Declassified Manhattan Project General Decimal File, File 600.12, Research, Records of the Army Corps of Engineers, RG 77, National Archives at College Park, College Park, MD.

<sup>52</sup> "Manhattan District History, Book VIII - Los Alamos Project (Y), Volume 1 - General," Olinger, "Los Alamos National Laboratory Sites and Facilities Potentially Eligible for Nomination to the National Register of Historic Places," "Schematic Plan of Field Work."

<sup>53</sup> "Manhattan District History, Book VIII - Los Alamos Project (Y), Volume 1 - General," Olinger, "Los Alamos National Laboratory Sites and Facilities Potentially Eligible for Nomination to the National Register of Historic Places," "Schematic Plan of Field Work."

<sup>54</sup> "Manhattan District History, Book VIII - Los Alamos Project (Y), Volume 1 - General" and "Schematic Plan of Field Work."

<sup>55</sup> Hawkins, *Project Y: The Los Alamos Story*.

<sup>56</sup> "Manhattan District History, Book VIII - Los Alamos Project (Y), Volume 1 - General" and Olinger, "Los Alamos National Laboratory Sites and Facilities Potentially Eligible for Nomination to the National Register of Historic Places."

<sup>57</sup> Hawkins, *Project Y: The Los Alamos Story*, 115, 116.

<sup>58</sup> U.S. Department of Energy 1986

<sup>59</sup> Hawkins, *Project Y: The Los Alamos Story*.

<sup>60</sup> Ibid., "Manhattan District History, Book VIII - Los Alamos Project (Y), Volume 1 - General," "Schematic Plan of Field Work."

---

<sup>61</sup> Roger W. Ferenbaugh, Thomas E. Buhl, Alan K. Stoker, and Wayne R. Hansen, *Environmental Analysis of the Bayo Canyon (TA-10) Site, Los Alamos, New Mexico* (Los Alamos, New Mexico: Los Alamos National Laboratory, 1982), LA-9252-MS, Hawkins, *Project Y: The Los Alamos Story*, "Schematic Plan of Field Work."

<sup>62</sup> Hawkins, *Project Y: The Los Alamos Story*, Olinger, "Los Alamos National Laboratory Sites and Facilities Potentially Eligible for Nomination to the National Register of Historic Places, "Schematic Plan of Field Work."

<sup>63</sup> Los Alamos National Laboratory, *Los Alamos: Beginning of an Era, 1943-1945* and U.S. Department of Energy 1986.

<sup>64</sup> "Manhattan District History, Book VIII - Los Alamos Project (Y), Volume 1 - General" and Olinger, "Los Alamos National Laboratory Sites and Facilities Potentially Eligible for Nomination to the National Register of Historic Places."

<sup>65</sup> Hawkins, *Project Y: The Los Alamos Story*, Olinger, "Los Alamos National Laboratory Sites and Facilities Potentially Eligible for Nomination to the National Register of Historic Places," "Schematic Plan of Field Work."

<sup>66</sup> Olinger, "Los Alamos National Laboratory Sites and Facilities Potentially Eligible for Nomination to the National Register of Historic Places," "Schematic Plan of Field Work."

<sup>67</sup> Olinger, "Los Alamos National Laboratory Sites and Facilities Potentially Eligible for Nomination to the National Register of Historic Places" and "Schematic Plan of Field Work."

<sup>68</sup> Hawkins, *Project Y: The Los Alamos Story*, Los Alamos National Laboratory, "Los Alamos National Laboratory: A Proud Past, An Exciting Future (Special Issue).", "Schematic Plan of Field Work."

<sup>69</sup> Los Alamos National Laboratory, *Los Alamos: Beginning of an Era, 1943-1945*.

<sup>70</sup> Hawkins, *Project Y: The Los Alamos Story*, Olinger, "Los Alamos National Laboratory Sites and Facilities Potentially Eligible for Nomination to the National Register of Historic Places," Hugh C. Paxton, *Thirty-Five Years at Pajarito Canyon Site* (Los Alamos, New Mexico: Los Alamos Scientific Laboratory, 1981), LA-7121-H, Rev.

<sup>71</sup> "Manhattan District History, Book VIII - Los Alamos Project (Y), Volume 1 - General," Olinger, "Los Alamos National Laboratory Sites and Facilities Potentially Eligible for Nomination to the National Register of Historic Places," Paxton, *Thirty-Five Years at Pajarito Canyon Site*.

<sup>72</sup> Rhodes, *The Making of the Atomic Bomb*.

<sup>73</sup> Hawkins, *Project Y: The Los Alamos Story* and Olinger, "Los Alamos National Laboratory Sites and Facilities Potentially Eligible for Nomination to the National Register of Historic Places."

<sup>74</sup> Hawkins, *Project Y: The Los Alamos Story* and Olinger, "Los Alamos National Laboratory Sites and Facilities Potentially Eligible for Nomination to the National Register of Historic Places."

<sup>75</sup> Olinger, "Los Alamos National Laboratory Sites and Facilities Potentially Eligible for Nomination to the National Register of Historic Places."

<sup>76</sup> "Manhattan District History, Book VIII - Los Alamos Project (Y), Volume 1 - General," Olinger, "Los Alamos National Laboratory Sites and Facilities Potentially Eligible for Nomination to the National Register of Historic Places," "Schematic Plan of Field Work."

<sup>77</sup> "Manhattan District History, Book VIII - Los Alamos Project (Y), Volume 1 - General" and "Schematic Plan of Field Work."

---

<sup>78</sup> Hawkins, *Project Y: The Los Alamos Story*, Olinger, "Los Alamos National Laboratory Sites and Facilities Potentially Eligible for Nomination to the National Register of Historic Places," "Schematic Plan of Field Work."

<sup>79</sup> "Manhattan District History, Book VIII - Los Alamos Project (Y), Volume 1 - General."

<sup>80</sup> Ibid. and Olinger, "Los Alamos National Laboratory Sites and Facilities Potentially Eligible for Nomination to the National Register of Historic Places."

<sup>81</sup> "Manhattan District History, Book VIII - Los Alamos Project (Y), Volume 1 - General."

<sup>82</sup> Ibid, Olinger, "Los Alamos National Laboratory Sites and Facilities Potentially Eligible for Nomination to the National Register of Historic Places."

<sup>83</sup> Hawkins, *Project Y: The Los Alamos Story* and Olinger, "Los Alamos National Laboratory Sites and Facilities Potentially Eligible for Nomination to the National Register of Historic Places."

<sup>84</sup> "Manhattan District History, Book VIII - Los Alamos Project (Y), Volume 1 - General" and Olinger, "Los Alamos National Laboratory Sites and Facilities Potentially Eligible for Nomination to the National Register of Historic Places."

<sup>85</sup> Hawkins, *Project Y: The Los Alamos Story* and Olinger, "Los Alamos National Laboratory Sites and Facilities Potentially Eligible for Nomination to the National Register of Historic Places."

<sup>86</sup> Olinger, "Los Alamos National Laboratory Sites and Facilities Potentially Eligible for Nomination to the National Register of Historic Places."



---

## Bibliography

- Ferenbaugh, Roger W., Thomas E. Buhl, Alan K. Stoker, and Wayne R. Hansen. *Environmental Analysis of the Bayo Canyon (TA-10) Site, Los Alamos, New Mexico*. Los Alamos, New Mexico: Los Alamos National Laboratory, 1982, LA-9252-MS.
- Gosling, F. G. *The Manhattan Project: Making the Atomic Bomb*. Washington, DC: U.S. Department of Energy, 2001, DOE/MA-0002.
- Hawkins, David, Edith C. Truslow, and Ralph Carlisle Smith. *Project Y: The Los Alamos Story*. Vol. II. The History of Modern Physics, 1800-1950: Tomash Publishers and the American Institute of Physics, 1988.
- Hoddeson, Lillian, Paul W. Henriksen, Roger A. Meade, and Catherine Westfall. *Critical Assembly: A Technical History of Los Alamos during the Oppenheimer Years, 1943-1945*. New York and Cambridge: Cambridge University Press, 1998.
- Los Alamos National Laboratory. "Los Alamos National Laboratory: A Proud Past, An Exciting Future (Special Issue)." *Dateline: Los Alamos*, 1995.
- \_\_\_\_\_. *Los Alamos: Beginning of an Era, 1943-1945*. Los Alamos, New Mexico: Reprinted by the Los Alamos Historical Society, 1993.
- Lyon, Fern, and Jacob Evans, ed. *Los Alamos: The First Forty Years*. Los Alamos, New Mexico: Los Alamos Historical Society, 1984.
- "Manhattan District History, Book VIII - Los Alamos Project (Y), Volume 1 - General," December 1947; (National Archives Microfilm Publication A1218, Roll 11); Records of the Defense Nuclear Agency; Record Group 374; National Archives at College Park, College Park, MD.
- Martin, Craig. *Quads, Shoeboxes and Sunken Living Rooms: A History of Los Alamos Housing The Los Alamos Story*, Monograph 4. Los Alamos, New Mexico: Los Alamos Historical Society, 2000.
- Olinger, Colleen. "Los Alamos National Laboratory Sites and Facilities Potentially Eligible for Nomination to the National Register of Historic Places," 1986; Attachment to letter from Robert Bradshaw, LANL Deputy Director for Support, to Harold Valencia, Manager, Los Alamos Area Office, U.S. DOE, April 18, 1986.
- Paxton, Hugh C. *Thirty-Five Years at Pajarito Canyon Site*. Los Alamos, New Mexico: Los Alamos Scientific Laboratory, 1981, LA-7121-H, Rev.
- Rhodes, Richard. *The Making of the Atomic Bomb*. New York: Simon and Schuster, 1986.

---

Rothman, Hal. *On Rims and Ridges, The Los Alamos Area Since 1880*. Lincoln, Nebraska: University of Nebraska Press, 1992.

"Schematic Plan of Field Work," ca.1944; Declassified Manhattan Project General Decimal File, File 600.12, Research, Records of the Army Corps of Engineers, RG 77, National Archives at College Park, College Park, MD.

Sparks, Ralph C. *Twilight Time: A Soldier's Role in the Manhattan Project at Los Alamos*. Los Alamos, New Mexico: The Los Alamos Historical Society, 2000.

Truslow, Edith C. *Manhattan District History: Nonscientific Aspects of Los Alamos Project Y, 1942 through 1946*. Los Alamos, New Mexico: The Los Alamos Historical Society, 1991.

U.S. Department of Energy *Phase 1: Installation Assessment, Los Alamos National Laboratory, Comprehensive Environmental Assessment and Response Program* (Working Draft). Albuquerque Operations Office, Albuquerque, New Mexico. On file at RRES-ECO, Los Alamos National Laboratory, Los Alamos, New Mexico, 1986.

U.S. National Park Service *National Register Bulletin: How to Complete Multiple Property Documentation Form*. <http://www.cr.nps.gov/nr/bulletins/nr16b.htm>, 1999. Accessed using Netscape on 1/28/99 at 8:28 AM.