

Identifier: **SOP-5146**
(formerly ENV-MAQ-206)

Revision: **0**



Effective Date: 4/2/2009

Next Review Date: 4/17/2014

Environmental Programs Directorate

Standard Operating Procedure

for **AIRNET—MAINTENANCE OF AIR SAMPLING PUMPS**

APPROVAL SIGNATURES:

Subject Matter Expert:	Organization	Signature	Date
C. Jake Martinez	WES-FFS	Signature on File	4/2/2009
Responsible Line Manager:	Organization	Signature	Date
Craig Eberhart	WES-EDA	Signature on File	4/2/2009

1.0 PURPOSE AND SCOPE

This standard operating procedure (SOP) states the responsibilities and describes the steps to rebuild, replace parts, perform preventive maintenance, test, and prepare new Gast vacuum pumps for service for the AIRNET monitoring system for the Los Alamos National Laboratory (LANL) Waste and Environmental Services Division (WES).

All WES participants shall implement this procedure when servicing the Gast vacuum pumps for the AIRNET monitoring system.

2.0 BACKGROUND AND PRECAUTIONS

2.1 Background

The Gast vacuum pump, model number 1023-101Q, is an oil-less vane-type pump connected to a $\frac{3}{4}$ horsepower General Electric or Emerson electric motor.

2.2 Precautions

Wear steel-toed shoes and practice correct lifting techniques anytime you are carrying or lifting pumps.

3.0 EQUIPMENT AND TOOLS

Keep the following minimum inventory of parts on hand. Refer to the parts list in Attachment 1 for part numbers.

- 10 O-rings (part number 58075-2-126 [Parker] or part number AK473 [Gast])
- 50 filters (part number AK524)
- 10 gaskets (part number AK522)
- 100 vanes (part number AK513)
- 15 inner bearings by Fafnir (part number 205PP)
- 15 outer bearings by Fafnir (part number 203KDD)

4.0 STEP-BY-STEP PROCESS DESCRIPTION

4.1 Servicing a Pump

Determine the type of maintenance needed on a pump by checking the number of hours run since the previous time maintenance was done. The following replacements are made on the schedule below:

- Pump filters are changed each time maintenance is done.
- The electrical cord is checked each time the maintenance is done.
- Pump vanes are changed after 6000 hours of operation.
- Bearings are changed after 12000 hours of operation.

Assemble the following parts and equipment before starting work on a pump:

- | | |
|---|--------------------|
| • 1/4- or 3/8-inch-drive socket set | • 2 new filters |
| • gasket scraper | • 2 new o-rings |
| • Phillips screwdriver | • 4 new pump vanes |
| • straight screwdriver | • vacuum gauge |
| • 9 piece open-end wrench set | • safety glasses |
| • feeler gauge set | |
| • torque wrench (1/4-inch drive, reading to at least 100 inch-pounds) | |

If bearings are to be replaced:

- | | |
|----------------------------------|------------------------|
| • hydraulic press | • new end shield plate |
| • new bearings (#6205 and #6203) | |
| • dial indicator | • tool tube (#777) |

Worker

1. Remove the two end caps from the muffler box.

2. Remove the filters from the end caps and replace with new filters. If vanes and bearings do not need to be replaced, go to step 26.

3. Remove muffler box from end plate; be careful not to damage gasket.

4. Remove the end plate from the body.

5. Remove the shroud from the electric motor.

6. Remove four vanes from the rotor; observe the orientation of the vane contact surfaces and the rotor for later reassembly.

7. In the hood, blow dust from all parts with compressed air.

Wear safety glasses or keep hood door lowered to calibrated level.

Worker

8. Check the condition of O-rings (on filters) and gaskets. Replace any O-rings that exhibit faint cracks when gently bent or seem stiffer than new O-rings. Replace gaskets that appear cracked.

9. If the rotor is stiff to turn or if the bearing hours are between 12,000 and 15,000, remove the shaft and replace inner and outer bearings by following steps 11 through 26.
If the bearings **do not need to be replaced**, go to step 24.

10. Remove the bolts holding the body using 3/16-inch allen wrench. Remove the body.

11. Remove the 4 through-bolts and the end shield from the electrical motor.

12. Remove the electrical motor shaft using a hammer and a 6-inch steel rod, making sure spring washers are kept in place. NOTE: If the spring washers are released, refer to Attachment 1. page 2, for proper reassembly.

13. Place motor shaft in the hydraulic press and remove the rotor using a 6-inch rod. Hold shaft while slowly pressing. Then remove the inner and outer bearings using the three-finger bearing puller on the vise.

14. In the hood, blow dust from the rotor and the motor housing with compressed air.
Wear safety glasses or keep hood door lowered to calibrated level.

15. Use hydraulic press to install new outer and inner bearings.

16. Ensure the round shim springs under the outer bearing are re-installed properly. Place motor shaft back into electrical motor housing.

17. Install a new tolerance plate, the inside pump end-plate, and the four through-bolts. Install nuts.

18. Torque the through-bolts to 30 inch-pounds.

19. Using a dial indicator mounted on a sleeve that can be attached to the shaft, check that the end plate is flat i.e reading stays at 0.000 inch as the shaft is turned through one revolution. To adjust, tighten the through-bolt on the side of the plate that is high. If the tolerance cannot be obtained after torquing any bolts to a maximum of 50 inch-pounds, loosen the bolts and insert a shim under the plate on the low side; this also may require a new end shield.

20. Slip a new control ring onto shaft and place electrical motor housing onto shelf of hydraulic press.

21. With the press, press rotor over control ring and into place on the shaft with a clearance of 0.002 inch. and no more than 0.003 inch (check with feeler gauge) between rotor and bearing housing.

22. Reattach body to electrical motor housing using the two allen-head bolts.

- Worker
-
23. Adjust the top clearance (between rotor and body) to factory specifications (0.002 inch and no more 0.003 inch) by
- loosening body bolts, and
 - lightly tapping on the pump body while turning the rotor.
- Turn the rotor and assure that all points on the rotor clear the body.
-
24. Replace the carbon vanes, the shroud, and the end plate (6 bolts) loosely.
-
25. Ensure the muffler housing gasket is installed straight and not pinched.
Ensure the O-rings on the end cap make a good seal on muffler box.
Torque the body, end plate, and muffler box bolts to 100 inch-pounds. Reinsert filters.
-
26. Inspect the electrical cord for any cracks, fraying, or damage. Replace if necessary.
-
27. Check that there is no electrical current from the pump body to the ground using a volt meter.
-
28. To ensure the reassembled pump was assembled correctly and that it will develop sufficient vacuum, connect the vacuum gauge to the inlet port and run the pump for a minimum of two minutes. Test pumps with new bearings for a minimum of 24 hours. Ensure the vacuum gauge maintains at least 21 inches of vacuum at the end of the test.
- CAUTION:** Operating the vacuum pumps inside TA-54-1001 for long periods may cause permanent hearing damage.
- Conduct long-term pump tests outdoors.
-
29. If the pump fails the test, remove endplate and install new vanes. If endplate is scored, regrind or replace and have the bearings replaced as described in steps 10 through 28. Remove and inspect body; if scored, replace. Remove and inspect rotor; if scored, replace. Reassemble and re-test. If second test fails, remove the pump from service.
-
30. Record in the pump log book **and** in the electronic database the identifier of the pump, the maintenance performed on it, and the date.

4.2 Preparing a new pump for service

- Worker
-
1. Assign an identifier to the pump and mark the pump with the identifier.
-
2. Install supporting feet and new vacuum fittings.
-
3. Obtain power cord (16-3 AWG U-L).
-

- Worker
4. Take off electrical cover plate from rear of motor and connect power cord to motor. Refer to the low-voltage diagram on motor case.
-
5. Using a volt-ohm meter, make sure motor is grounded. Test between the ground prong on the plug and the motor case. If no reading is obtained, check the ground connection on the pump.
-
6. Connect vacuum gage to the inlet port and run the pump for a minimum of five minutes. Ensure the vacuum gage reads a vacuum of at least 21 inches of mercury at the end of the test.

CAUTION: Operating the vacuum pumps inside TA-54-1001 may cause long-term hearing damage.

Conduct long-term pump tests outdoors. Pumps may be operated inside TA-54-1001 **for a maximum of two minutes** during work hours **OR** overnight. At the start of each work day, turn off any operating pumps and run them outside the building, if needed.
-
7. If the pump fails the test, return pump to factory for servicing (Gast Manufacturing Corp., 2300 Highway M-139, Benton Harbor, MI 49023-0097; phone 616-926-6171).
-
8. Record in the pump log book **and** in the electronic database the identifier of the new pump, the preparation steps performed on it, and the date.
-
9. Store pumps on the shelf in the appropriate storage area (TA-54-1001).

4.3 Records Management

- Worker
1. Maintains and submits records and/or documents generated to the Records Processing Facility according to EP-DIR-SOP-4004, Records Transmittal and Retrieval Process.

5.0 DEFINITIONS

N/A

6.0 PROCESS FLOW CHART

N/A

7.0 ATTACHMENTS

Attachment 1 Exploded View of Pump and Parts (2 pages)

8.0 REVISION HISTORY

Revision No. <i>[Enter current revision number, beginning with Rev.0]</i>	Effective Date <i>[DCC inserts effective date for revision]</i>	Description of Changes <i>[List specific changes made since the previous revision]</i>
0	12/18/95	New document.
1	9/24/96	Added steps describing bearing replacement.
2	7/16/97	Added more steps and details on power cord installation and bearing replacement.
3	1/25/99	Added caution about hearing damage and rules for operating pumps inside Cave, requirement for wearing steel-toed shoes when carrying pumps, and note on bearing failures in Emerson motors.
4	4/27/99	Added some steps and clarified other steps to add more detail.
5	12/14/04	Updated to refer to new IWD for pump rebuilding work and minor changes to adjustment specifications.
6	01/05/06	Removed obsolete text on bearing failures and bearing types, other minor changes throughout.
0	4/2/2009	New document number and reformatted for WES division. Formerly ENV-MAQ-206.

ATTACHMENT 1: EXPLODED VIEW OF PUMP AND PARTS

SOP-5146-1

Exploded View of Pump and Parts

Records Use only

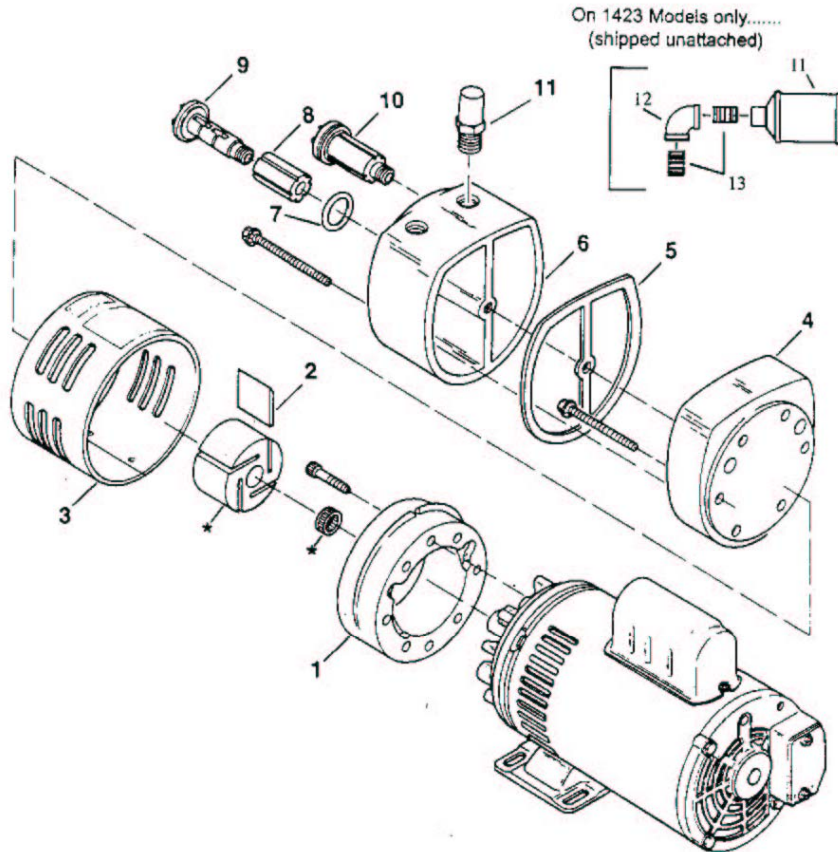

Part No.	Description	Qty	0823-101	0823-101Q	1023-101	1023-101Q	1423-101	1423-101Q
1	Body	1	AK517	AK517	AK518	AK518	AL283	AL283
2	Vane	4	AK513	AK513	AK513	AK513	AL284	AL284
3	Shroud	1	AK511	AK511	AK511	AK511	AL281	AL281
4	End Plate	1	AK515A	AK514	AK515A	AK514	AK515A	AK514
5	Gasket	1		AK522		AK522		AK522
6	Muffler Box	1		AK520		AK520		AK520
7	O-Ring	2		AK473		AK473		AK473
8	Felt	2		AK524		AK524		AK524
9	End Cap	2		AK510		AK510		AK510
10	End Cap Asm	2		AK526		AK526		AK526
11	Filter/Muffler	1	AK840	AK840	AK840	AK840	AC432	AC432
12	Elbow	1					BA206	BA206
13	Nipple	2					BA714	BA714
	Service Kit	1	K479A	K479	K479A	K479	K575A	K575A

- Denotes parts included in a Service Kit. When corresponding or ordering parts, please give complete model and serial number.
- FOR ORIGINAL EQUIPMENT MANUFACTURERS SPECIAL MODELS CONSULT YOUR LOCAL DISTRIBUTOR.

ATTACHMENT 1: EXPLODED VIEW OF PUMP AND PARTS

SOP-5146-1

Exploded View of Pump and Parts

Records Use only

