

Department of Petroleum Engineering
LOUISIANA STATE UNIVERSITY AND AGRICULTURAL AND MECHANICAL COLLEGE
BATON ROUGE - LOUISIANA - 70803-6417

504.388.5215

2/8/85

J. B. Lowenhaupt
Regional Supervisor
District Operations
Minerals Management Service
P.O. Box 7944
Metairie, LA 70010

Dear Mr. Lowenhaupt:

Enclosed is a copy of my report concerning gas trapped in a subsea BOP stack during well control operations. I greatly appreciated the information provided by your office for this research. Please let me know if I can be of any further assistance.

Truly yours,

AT Bourgoyne, Jr.
Adam T. Bourgoyne, Jr.
Campanile Professor of Offshore
Mining and Petroleum Engineering

ATB/mab

enclosure

ZAPATA
LEXINGTON

A CONFIDENTIAL REPORT

on

The September 14, 1985 Fire
occurring on the Zapata Lexington
in Green Canyon Block 69, Lease OCS-G 5893



by

Adam T. Bourgoyne, Jr.
Petroleum Engineering Department
Louisiana State University

January, 1985

TABLE OF CONTENTS

1. INTRODUCTION 1

2. ACCIDENT DESCRIPTION 3

 2.1 Kick Pump-out Phase 3

 2.2 Calculation of Trapped Gas Volume 8

 2.3 Removal of Trapped Gas 13

 2.4 Circulation of Marine Riser 17

3. ALTERNATIVE PROCEDURES USING EXISTING EQUIPMENT 22

 3.1 Surface Gas Handling 23

 3.2 Reduction of Gas Flow Rate 24

 3.3 Reduction of Trapped Gas Volume 24

 3.4 MMS Survey of Field Practice 26

4. ALTERNATIVE EQUIPMENT DESIGNS 29

5. IDENTIFICATION OF SIMILAR HAZARDS 32

6. CONCLUSIONS AND RECOMMENDATIONS 34

 APPENDIX A A1

 APPENDIX B B1

 APPENDIX C C1

2. ACCIDENT DESCRIPTION

A description of the well geometry just prior to the accident is shown in Figure 1. Information used in this description was obtained from an MMS Accident Report received by Darrell Griffin dated 9-14-84. The sequence of emergency well control operations began at approximately 5:00 AM on 9-14-84 while drilling at 9535-ft RKB when the well began to flow. The mud density in the borehole at that time had a density of 12.5 lb/gal, a plastic viscosity of 22 cp, and a yield point of 8 lb/100 ft². Because of the problem of low fracture resistance when drilling in deep water, a rather extensive casing program was being followed. A second intermediate string of casing has been set at 8588-ft RKB. The casing seat had been tested to a pressure equivalent to a 15.5 lb/gal mud. The upper annular blowout preventer was closed after the flow was detected and shut-in pressures of 200 psig and 1000 psig were recorded on the drill pipe and choke line respectively. The initial pit gain was reported to be 30 bbl.

The equivalent mud density at the casing seat at the time the blowout preventer was closed can be computed from the shut-in well conditions. The theoretical value calculated is 14.8 lb/gal. This value is based on an estimated true vertical depth at the casing seat of 8240-ft. Note that the theoretical value is 0.7 lb/gal less than that required to cause formation fracture at the casing seat.

Kick Pump-Out Phase

The shut-in drill pipe pressure of 200 psig indicated that the mud weight must be increased from 12.5 lb/gal to a little over 12.9

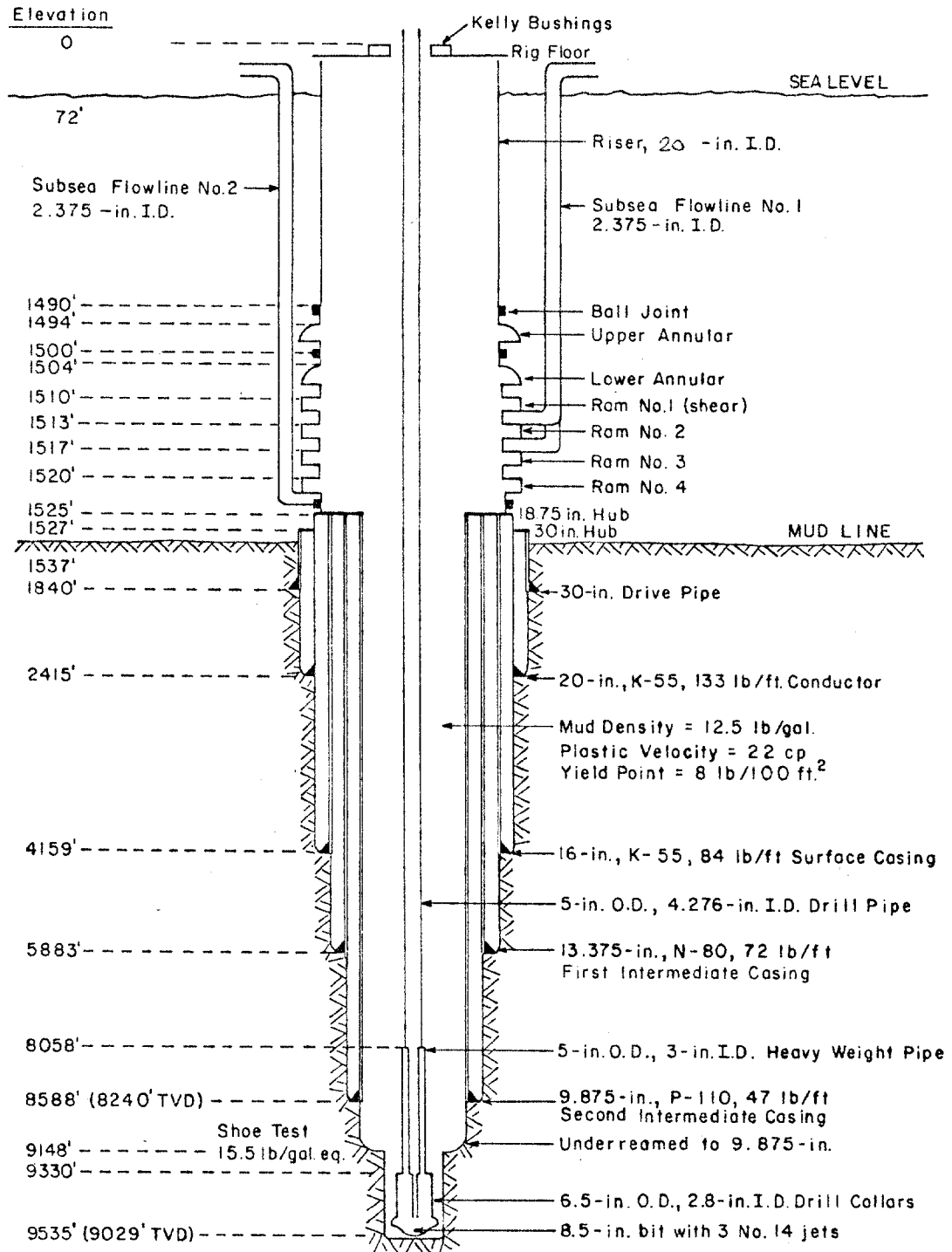

FIGURE 1. DISCRIPTION OF WELL GEOMETRY JUST PRIOR TO ACCIDENT
(NOT TO SCALE)

lb/gal to balance formation pressure. The mud density was increased to 13.1 lb/gal and well control operations were initiated at about 6:00 AM with returns taken from the wellhead to the surface through subsea flowline No. 2 (See Fig. 1). A pump speed of 40 spm provided a kill speed of about 4.7 bbl/min during the well control operation. The initial circulating drill pipe pressure was about 1000 psig.

At about 7:15 AM, after pumping 350 bbl of kill mud, a flowline became cut-out and circulation was stopped while a clamp patch was installed to stop the leak. Circulation was then resumed at 30 spm (3.5 bbl/min) with a circulating drill-pipe pressure of 400 psig. The choke pressure peaked at about 3100 psig when gas reached the surface. After pumping approximately 480 bbl of mud, circulation had to be stopped temporarily in order to mix mud. Mud was being lost to the well, indicating formation fracture had occurred. A pit level record is shown in Fig. 2.

At about 11:00 AM, after pumping 760 bbl of mud, the kick pump-out was felt to be complete and the pump was again stopped. The shut-in drill-pipe pressure and casing pressure was observed to be zero. However, when the choke was opened to check for flow, a minor flow was still observed. Such a flow would be expected due to the expansion of trapped gas in the BOP stack as pressure is reduced. The reduction in pressure occurs due to the removal of choke line frictional pressure loss when circulation is stopped. Circulation of the well was resumed and preparations were begun for the next phase of the well control operations.

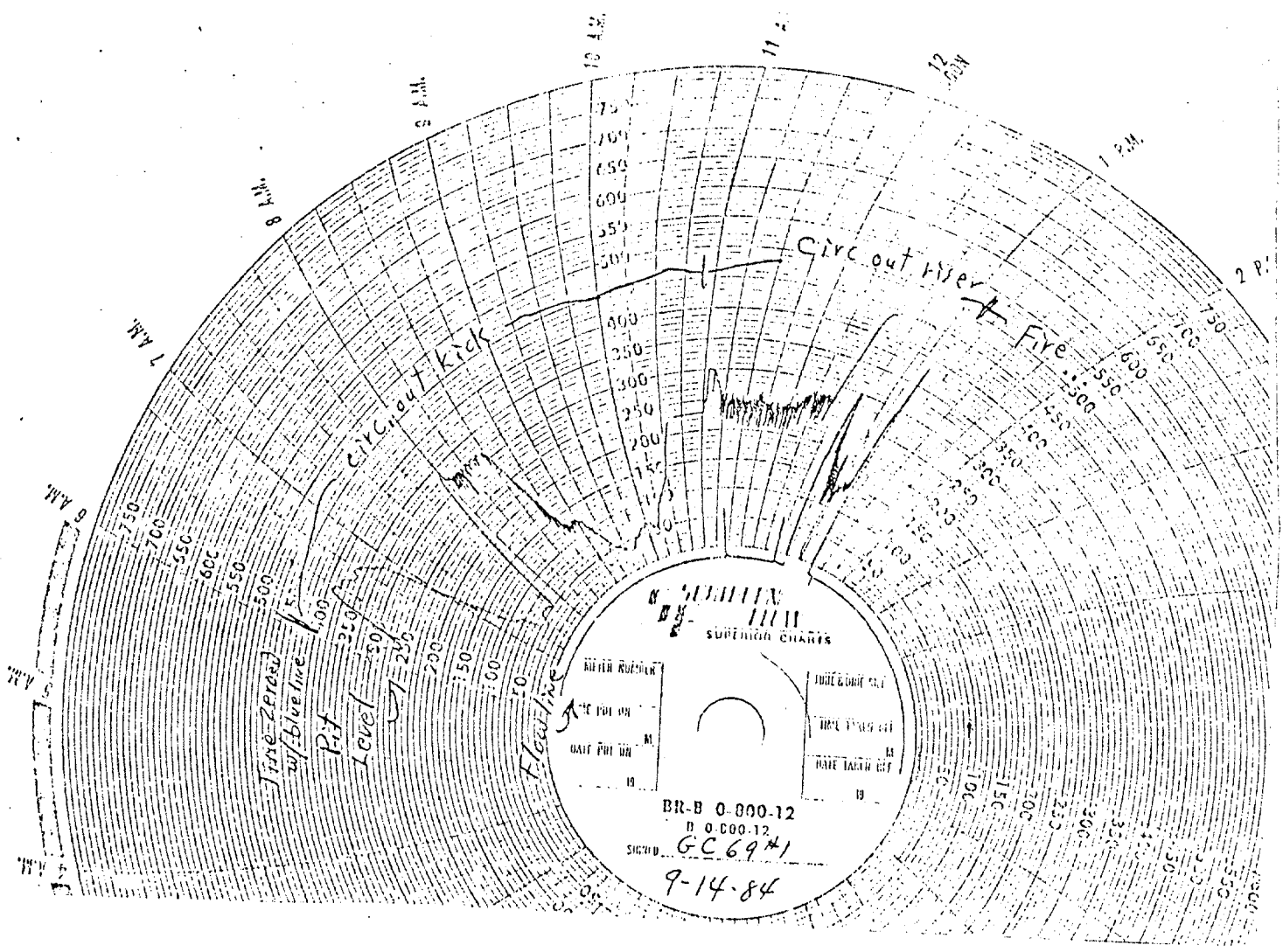

FIGURE 2. PIT LEVEL AND FLOWLINE INDICATOR RECORD

A computer simulation was made in order to obtain a better understanding of the subsurface well conditions existing during the time period when the kick was being circulated from the well. The results of the simulation is shown in Appendix A. The results indicate that the initial pit gain reported is not consistent with the shut-in drill-pipe and choke pressures reported. A much larger kick (80-85 bbl initial gain) is necessary to explain the 800 psig difference between the shut-in choke pressure and drill-pipe pressure. The simulation also indicates that it should have been possible to pump-out the kick without exceeding the shoe test pressure if special well control procedures for deep-water well conditions were followed. However, if conventional well control procedures were followed, the high frictional pressure drop in the subsea choke line (approximately 400 psig) would have likely resulted in formation fracture. It is not known if special procedures designed to negate the effect of frictional pressure drop in the subsea choke line were attempted. However, the reported initial circulating drill-pipe pressure of 1000 psig suggests that conventional well control procedures were followed.

The results of the computer simulation predict that for perfect choke operation, a peak choke pressure of about 2400 psig would have been observed. Following conventional well control procedures rather than special procedures for deep-water drilling conditions would increase this peak value from 2400 to 2800 psig, which is still 300 psig less than the 3100 psig observed. This difference is probably

due to (1) choke operator error and (2) the effect of gas coming out of solution from the mud. The computer simulation does not take into account either of these possibilities. The peak pressure also occurred later than predicted in the computer simulation. This is due to the loss of mud to a fractured formation.

Shown in Fig. 3 are schematics illustrating the subsurface well conditions determined by computer simulation at various times in the kick pump-out phase of the well control operations. This figure illustrates how gas was trapped in the blowout preventer stack at the seafloor at the end of this phase of the well control operation.

Calculation of Trapped Gas Volume

The accident report indicates that the gas kick was circulated out of the well with (1) the upper annular preventer closed and (2) returns from the seafloor to the drilling vessel taken from subsea flowline No. 2. This flowline reportedly communicates with the well at an elevation just below the lower pipe rams as shown in Fig. 4. Thus, gas would be trapped from below the sealing elements in the 21.25-in. bore upper annular preventer, downward through an 18.75-in.

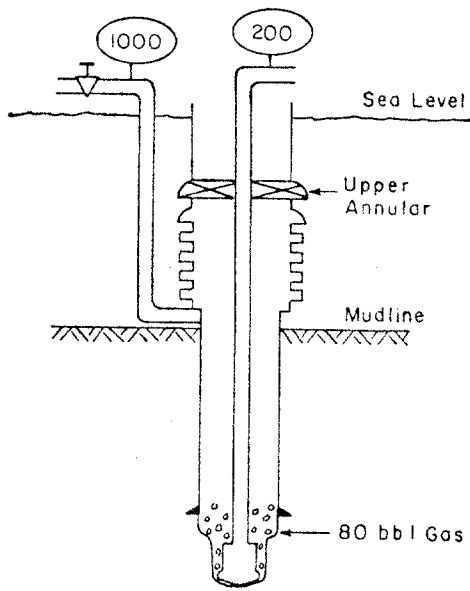

(a) Initial Kick Conditions

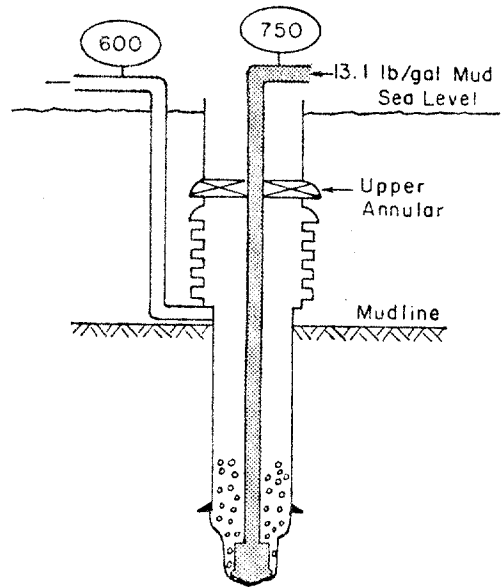

(b) After Initiating Kill Mud

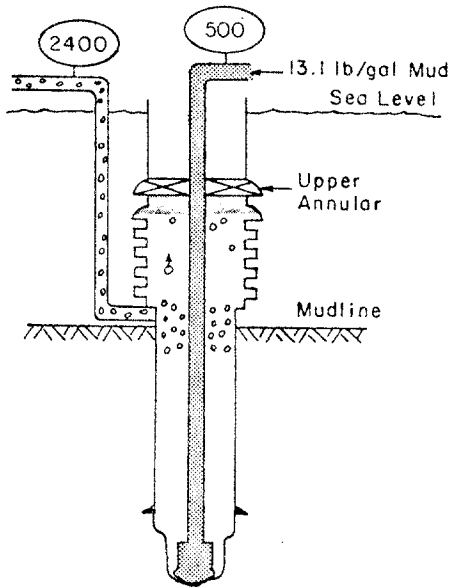

(c) Peak Choke Pressure

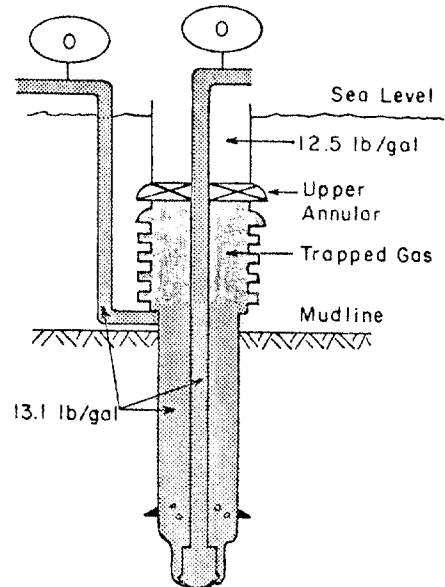

(d) After Pumping Out Kick

FIGURE 3. SIMULATION OF WELL CONDITIONS DURING PUMP-OUT PHASE OF WELL CONTROL OPERATIONS

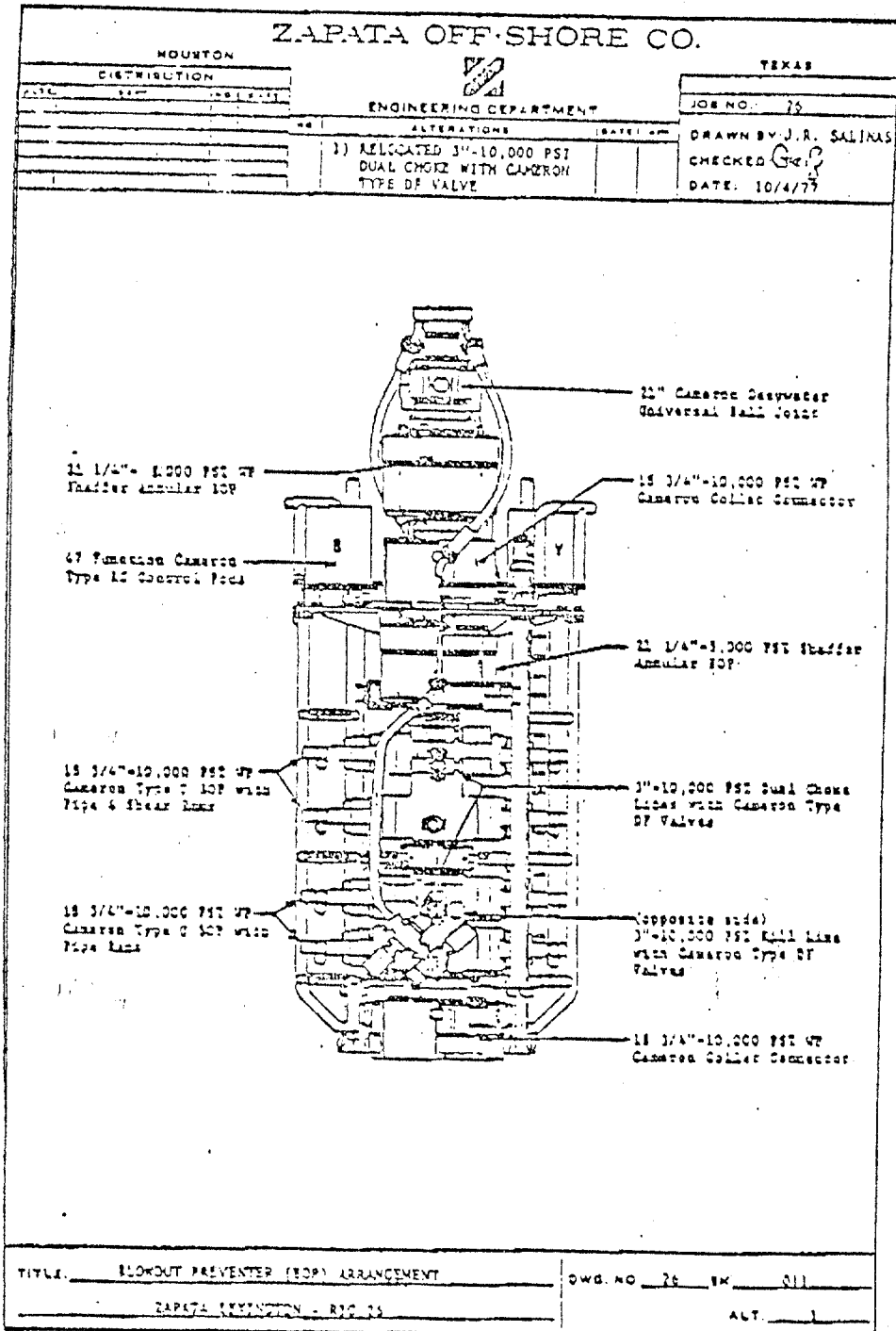

FIGURE 4. BLOWOUT PREVENTER ARRANGEMENT

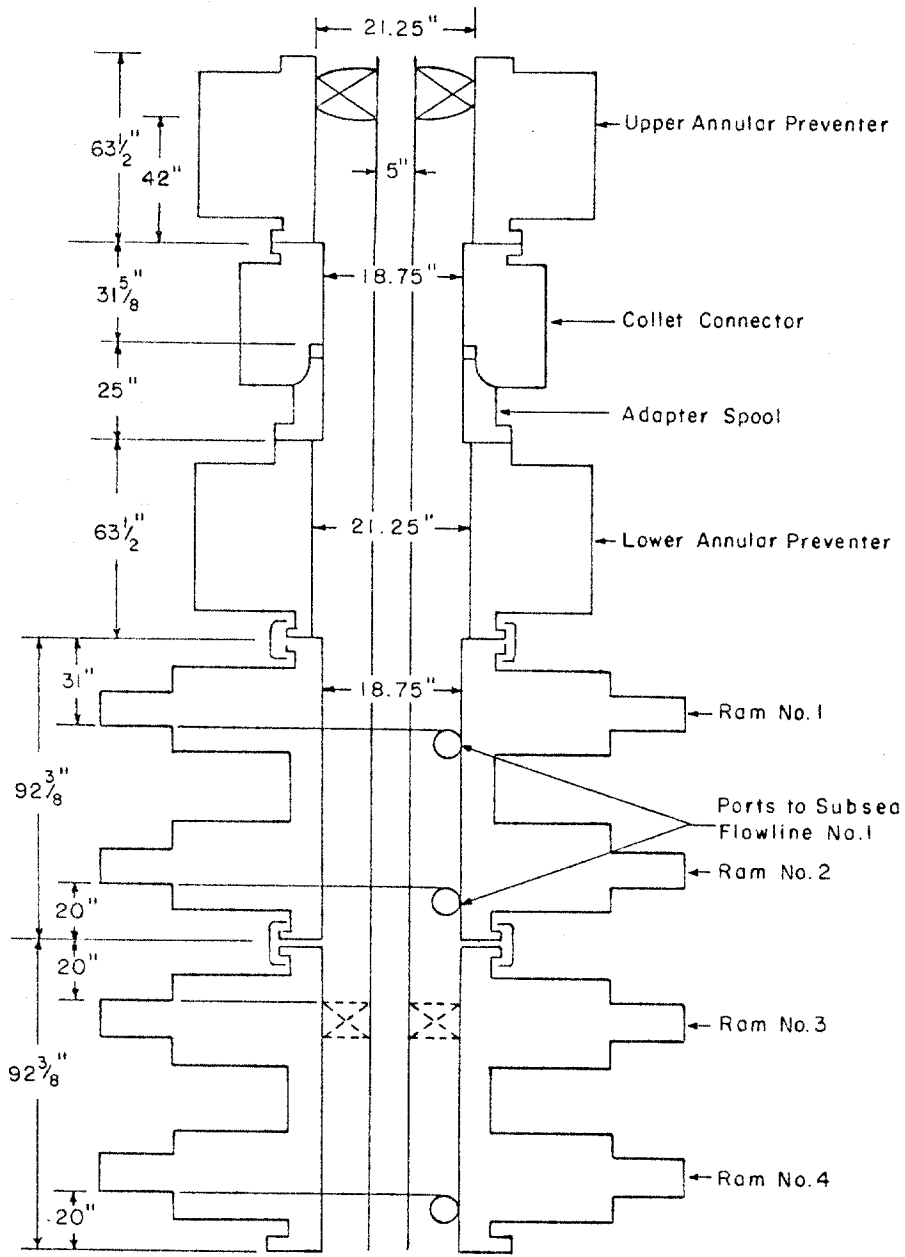

FIGURE 5 . DIMENSIONS OF BLOWOUT PREVENTER STACK CAVITY

TABLE 1 - Calculation of Trapped Gas Volume

Description	O. D.	I. D.	Length	<u>Trapped Gas Volume</u>		
	(in.)	(in.)		(in. ³)	(gal)	(bbl)
<u>Closed Upper Annular</u>	21.25	5.0	42	14,071	60.9	1.45
<u>Collet & Adapter</u>	18.75	5.0	57	14,619	63.3	1.51
<u>Open Lower Annular</u>	21.25	5.0	64	21,441	92.8	2.21
Subtotal				50,131	217.0	5.17
<u>Ram Volume</u>						
To Top Flowline Port	18.75	5.0	31	7,951	34.4	0.82
To Middle Flowline Port	18.75	5.0	73	18,723	81.1	1.93
To Bottom Flowline Port	18.75	5.0	166	42,576	184.3	4.39
To Top of Ram 3	18.75	5.0	113	28,982	125.5	2.99
<u>TOTAL TRAPPED GAS</u>						
To Top Flowline Port				58,082	251.4	5.99
To Middle Flowline Port				68,854	298.1	7.10
To Bottom Flowing Port				92,707	401.3	9.56
To Top of Ram 3				79,113	342.5	8.16

collet connector assembly, through a 21.25-in. bore lower annular preventer, and through two 18.75-in. bore double ram preventers. Drawings of this Cameron BOP stack indicates the dimensions shown in Fig. 5 and trapped gas volumes shown in Table 1.

At the time of the completion of the pump-out phase of the well control operations, 9.56 bbl of gas was trapped in the BOP stack. The pressure of this gas was about 1300 psia, which is the hydrostatic head of 13.1 lb/gal mud at a depth of 1525 ft., plus the choke line friction at 30 spm. This high pressure gas is capable of expanding to a volume of about 4,750 SCF at atmospheric pressure.

Removal of Trapped Gas

In order to remove the high pressure gas trapped in the BOP stack, the cementing unit was lined up to pump seawater down subsea flowline No. 1. Ten barrels of seawater was pumped down this line while continuing to circulate mud down the drill-pipe using the rig mud pump, with returns being taken from the wellhead to the surface choke manifold through subsea flowline No.2. The cementing unit was operated at a slow rate of about 30 spm, with only about 400 psi pump pressure. After displacing 10 bbl of seawater, which is a little more than needed to completely fill subsea flowline No.1 with 8.5 lb/gal seawater, both the cementing pump and the rig mud pump were stopped. The No. 3 pipe rams were then closed and a trapped gas section of 8.16 bbl was isolated between the upper annular and the No. 3 rams.

After closing the No. 3 pipe rams, subsea flowline was opened at the surface. However, the accident sequence at this point is not clear from the information available. One account of the accident sequence indicates that the pressure on subsea flowline No. 1 was allowed to bleed about 14 bbl of seawater and mud before opening the upper annular preventer. Another account of the accident sequence indicates that the upper annular preventer was opened soon after opening subsea flowline No.1, and that the preventer was open while the 14 bbl of seawater and mud were recovered. Both possibilities are discussed below.

If the annular preventer remained closed while subsea flowline No. 1 was vented, the pressure on the trapped gas was initially reduced from 1300 psia to 690 psia. This pressure reduction would permit the gas to expand into subsea flowline No. 1. The theoretical amount of initial expansion would be from 8.16 bbl to 15.40 bbl. This would push some seawater out of flowline No. 1 back to the vent at the surface. Loss of water from flowline No. 1 further reduces the hydrostatic pressure on the trapped gas, causing additional expansion. For example, if the gas expands by 7.23 bbl (from 8.16 to 15.40), the vertical section of subsea flowline No. 1 should contain 7.23 bbl of gas out of a total capacity of 8.36 bbl. This would reduce the hydrostatic pressure to about 100 psia which would in turn cause the gas volume to expand to a total volume of 106 bbl. The limiting factor of this process is the amount of seawater which could be gas lifted out of subsea flowline No. 1 before gas breaks through to the surface and is released. The liquid holdup or water fraction

in the flowline would be the only significant contributor to the hydrostatic pressure on the trapped gas. If all the liquid could be removed, the pressure of the trapped gas could be reduced to almost atmospheric pressure. (See Fig. 6.)

The accident report indicates that about 10 bbl of seawater and 4 bbl of mud were recovered from flowline No. 1 during the venting operation. This is more than would be expected, but considering the accuracy of the field measurement, it is not too surprising. Also, since the annular preventer is not designed to hold pressure above with no pressure below, it is possible that some mud leaked from the marine riser to the BOP stack, and up subsea flowline No. 1. No mention was made as to how much gas was vented, or if the vent line pressure was allowed to bleed to zero at the surface. If this was done without the BOP leaking, the amount of gas remaining in the BOP stack should have been reduced to a much safer level, perhaps to as little as 300 scf.

If the upper annular preventer was opened soon after opening subsea flowline No. 1, it would have allowed mud under a hydrostatic pressure of about 1000 psia in the riser to flow downward into the blowout preventer stack. Many drilling personnel believe that the downward flow of mud can sweep the gas downward and out of the BOP stack through the subsea flowline. Use of this procedure would better explain the recovery of 14 bbl of seawater and mud from subsea flowline No. 1.

It is not at all clear that the downward flow of mud through the

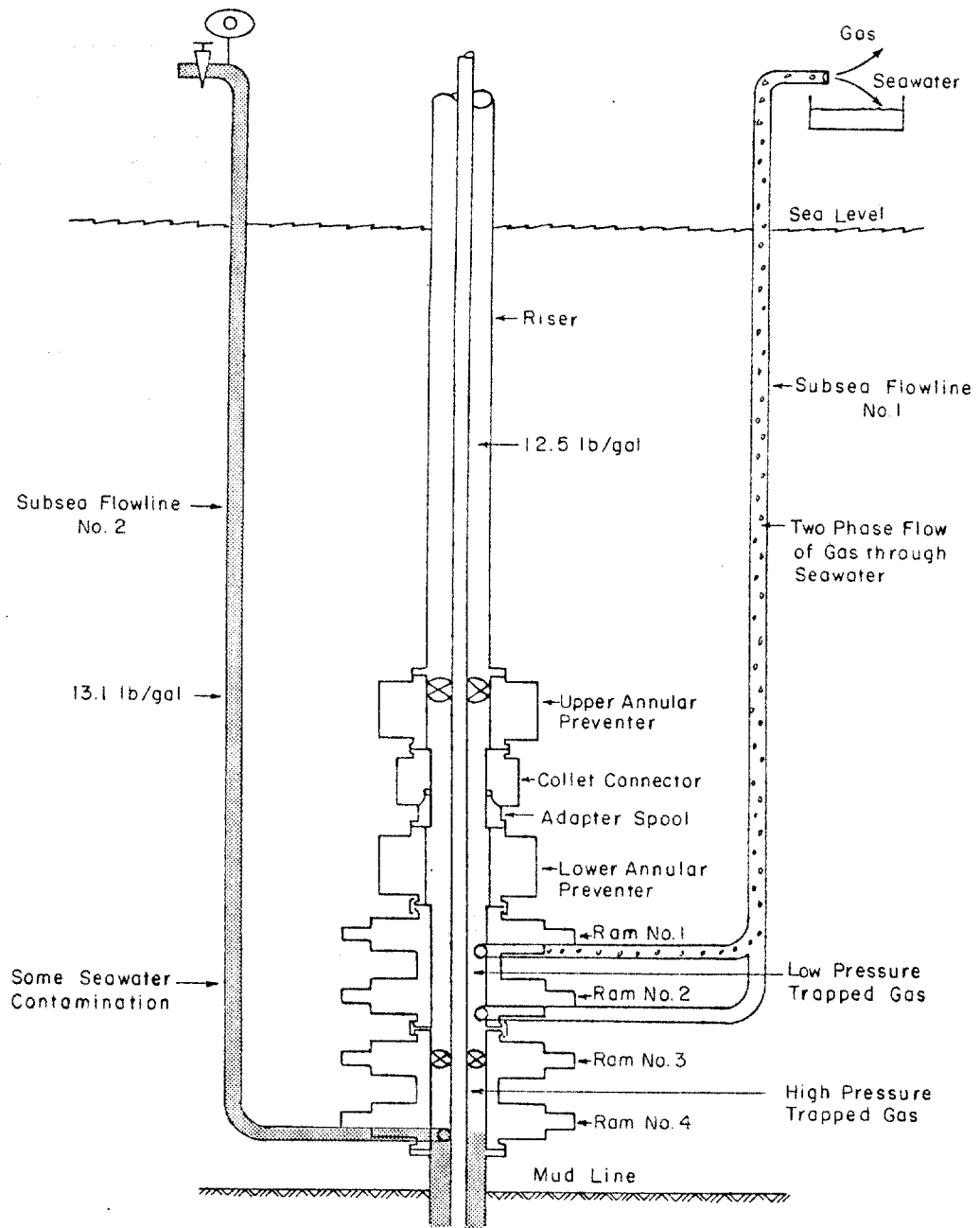

FIGURE 6. RELEASE OF PRESSURE ON TRAPPED GAS- VERSION I

BOP stack could reach a great enough velocity to carry the gas downward. Since gas has a much lower density than mud, it tends to slip upward through the mud. The downward mud velocity must be greater than the gas slip velocity for this procedure to be successful. Unfortunately, this exact situation has not been studied experimentally and limits of conditions under which the procedure could succeed cannot be predicted. However, Dr. Bourgoyne believes that it is likely that relatively large gas bubbles with high slip velocities would result when an annular preventer above trapped gas is opened. If this is true, most of the gas would have escaped upward into the riser while the mud flowed downward (Fig. 7).

Circulation of Marine Riser

After recovery of 14 bbl of seawater and mud from subsea flowline No. 1, the next phase of the well control operation was to circulate kill mud into the marine riser. This was accomplished in the conventional manner by pumping 13.1 lb/gal mud down subsea flowline No. 1, up through the upper part of the BOP stack, and into the bottom of the marine riser. Returns from the top of the marine riser were taken from the normal atmospheric pressure flowline to the shale shaker. In this phase of the operation the remaining gas in the system would be circulated to the surface.

The exact amount of gas released to the marine riser cannot be determined from the available information. It could have been as little as a fraction of a barrel to as much as 8.16 bbl. However, if

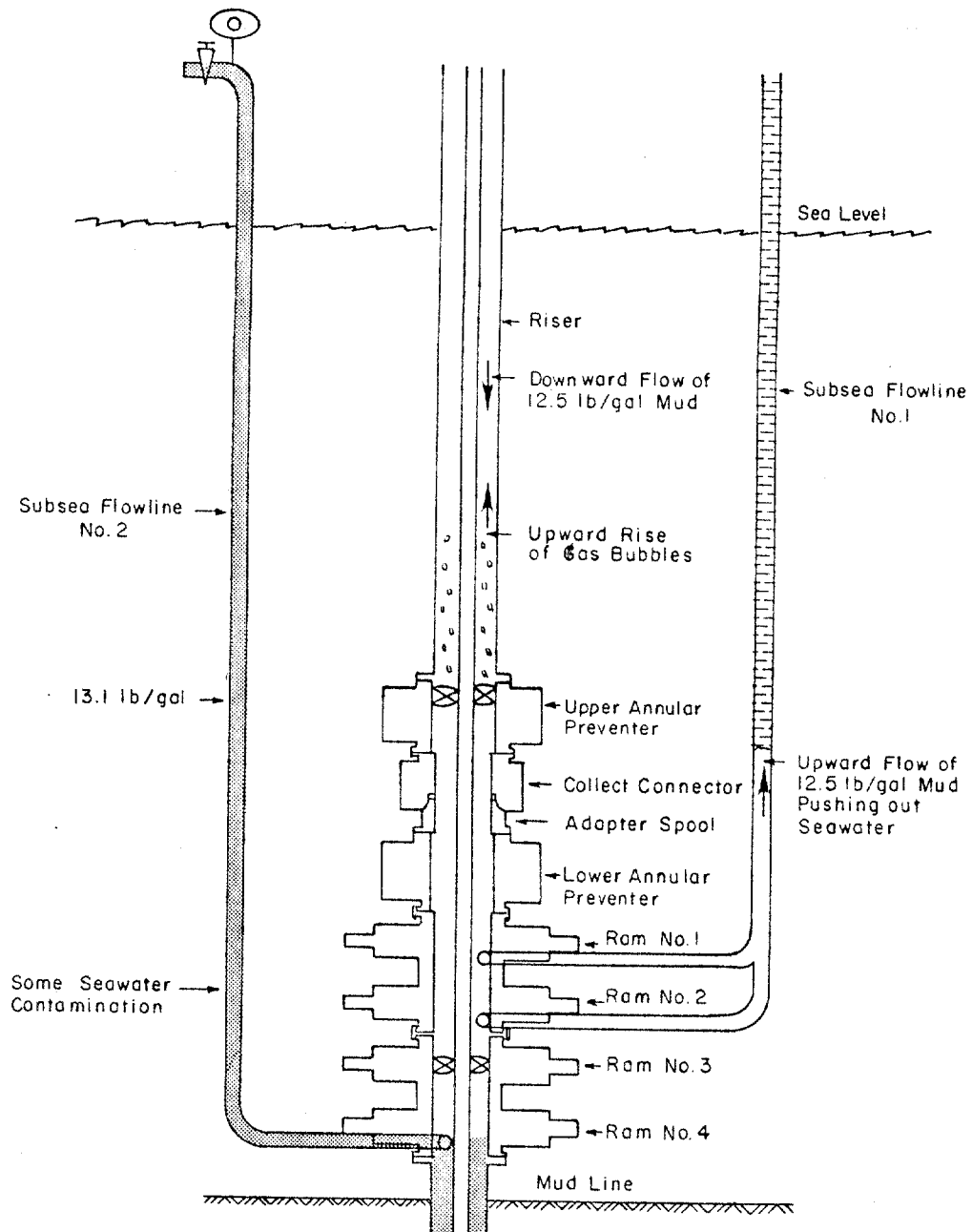

FIGURE 7. RELEASE OF PRESSURE ON TRAPPED GAS— VERSION 2

ram No. 3 did not leak, it could not have been any greater than 8.16 bbl at about 1300 psia. Assuming the worst case, the 8.16 bbl of gas at 1300 psia would have expanded to about 10.6 bbl upon entering the bottom of the marine riser at 1000 psia pressure.

The flowline arrangement at the top of the marine riser is shown in Fig. 8. A diverter head at the top of the marine riser prevents hydrocarbons from venting through the rig floor. Three possible flow paths were possible from the riser below the diverter head. The effluent could be diverted overboard on either the port or starboard side of the drilling vessel, or it could be routed through the normal flowline to return mud through a gumbo box, shale shakers, and into the active mud tanks. The later arrangement was used to circulate kill mud into the marine riser.

The calculated volume of the marine riser was 555 bbl. After approximately 455 bbl of mud had been pumped down subsea flowline No. 1, a severe flow was observed at the gumbo box, and shale shaker below the rig floor. Flow was so severe that mud was being lost overboard. Gas from this flow ignited, leading to the ignition of other flammable material in the rig floor area. The fire caused the loss of four lives.

The flowline indicator record (Fig. 2) indicates that the period of severe flow started about 90 minutes after circulation of the marine riser began, and lasted about 30 minutes. It is not known how long after the initial gas flow started before the gas ignited. It was estimated that the fire lasted 45 minutes. Not all of the fire

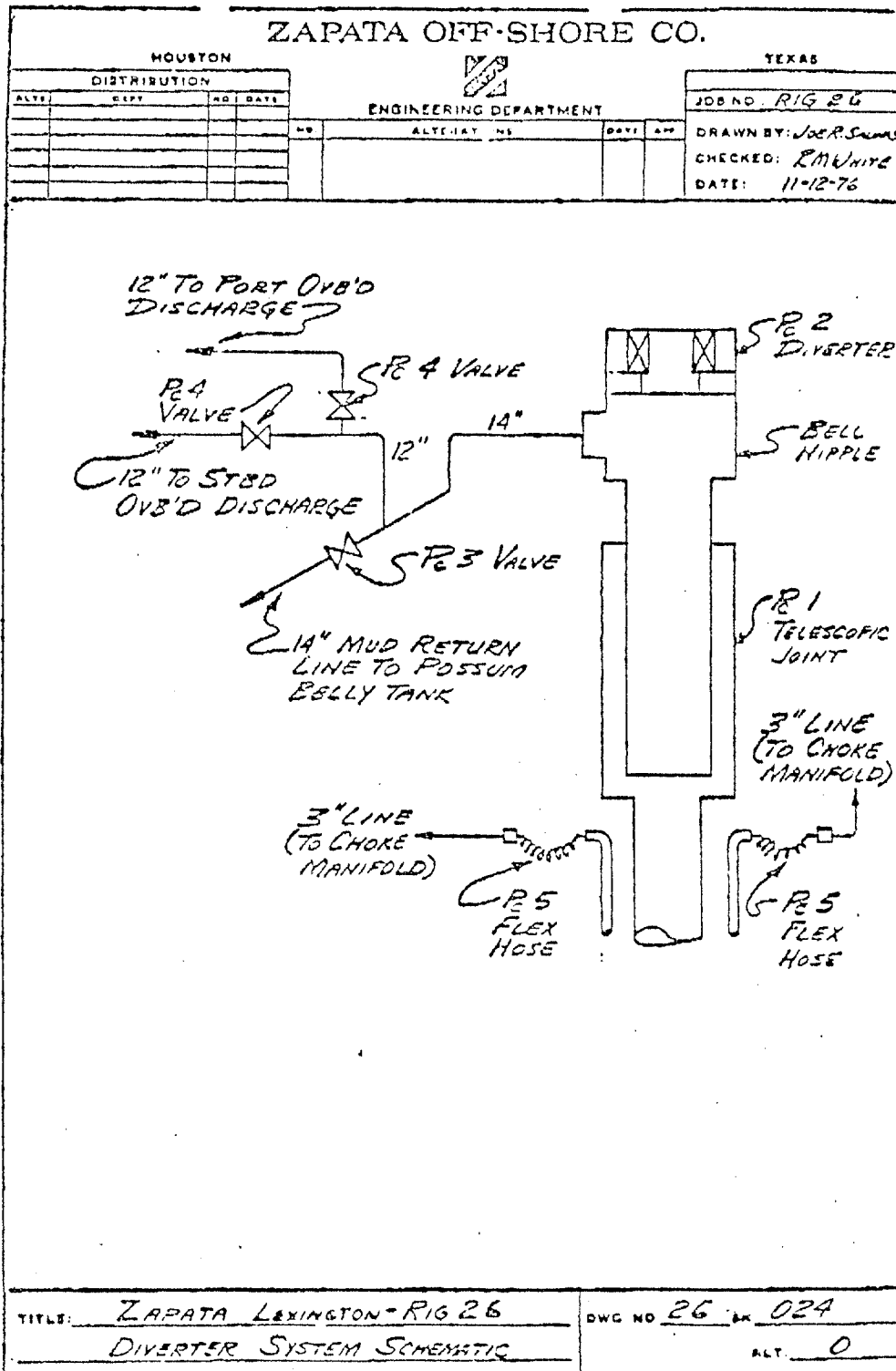

FIGURE 8. DIVERTER SYSTEM SCHEMATIC

was due to the gas flow. Once the fire started, at least one drum of flammable material, and several hoses containing hydraulic oil caught fire.

Computer simulations were made in order to obtain a better understanding of the subsea conditions existing during the time that kill mud was being circulated in the marine riser. Various amounts of trapped gas volumes were assumed to exist in the marine riser, up to a maximum of 10.6 bbl.

The results of the computer simulations indicate that at least 5 bbl of trapped gas must have entered the bottom of the marine riser to explain the violent flow and loss of mud at the surface. This volume of trapped gas would result in a peak mud flow rate at the gumbo box and shaker areas of about 20-25 bbl/min. The best match of the pit level and flowline indicator record (Fig. 2) was obtained by assuming that 10.6 bbl of trapped gas entered the bottom of the marine riser.

Computer simulation results for an initial gas volume of 10.6 bbl are given in Appendix B. These computed results predict a violent flow (20-30 bbl/min) occurring about 90 minutes after circulation was started. The predicted peak pit gain was about 130 bbl, which was somewhat less than the 175 bbl peak gain indicated in the pit volume record (Fig. 2). However, the computed peak pit gain is quite sensitive to the two phase flow pattern and pressure gradient existing in the upper part of the riser and diverter system. These parameters cannot yet be accurately predicted. This is one of the

areas currently under study in the MMS research program. In addition, the accuracy of the pit level record of Fig. 2 is not known. The general agreement between the computed behavior and the accident report appeared to be close enough to verify that the accident was probably caused by gas originally trapped in the BOP stack and then released to the marine riser.

3. ALTERNATIVE PROCEDURES USING EXISTING EQUIPMENT

It is likely that the accident occurred because the rig crew was not expecting the violent release of gas from the marine riser at the surface and had not prepared for this situation. Furthermore, it is likely that the crew believed that the procedure followed for the removal of trapped gas from the BOP stack was successful and that any gas remaining would be small in volume and could be easily handled as they had done previously on wells drilled in more shallow water depths. The hazard was greatly increased by the increased pressure at the BOP stack caused by the deeper water. Problems of this type and magnitude have probably been experienced before on a few rigs, but without ignition of the gas.

If the hazard had been fully recognized, several steps could have been taken to greatly reduce the risk using existing rig equipment. These steps can be broken into the following three categories:

1. Steps to more safely handle the release of gas at the surface.
2. Steps to reduce the maximum gas flow rate at the surface.
3. Steps to reduce the volume of trapped gas released to the riser.

All of these areas are important, but the first area is the most important. As will be discussed later, there are many drilling situations which can lead to gas entering the marine riser and it will not be feasible to develop a fail-safe method for preventing all of these situations.

3.1 Surface Gas Handling

As soon as it is recognized that significant volumes of gas is in the marine riser, steps can be taken to route the flowstream through an appropriate gas handling facility. It should be possible to recognize that gas is in the marine riser from the observed pit gain prior to gas reaching the surface. For example, the computer simulations of Appendix B predicted a 20 bbl gain when the top of the gas was at 850 ft, and about 30 minutes before gas reached the surface. At this time, steps could have been taken:

1. To insure the diverter head was closed.
2. To route the mud through a mud gas separator prior to releasing the mud at the shale shaker.

It is not clear if a flowline to a mud gas separator was available on the Zapata Lexington. However, such an arrangement is sometimes used and is highly desirable.

In the event that flow could not be routed to a mud gas separator, it could be diverted overboard. The purpose of a diverter system is to divert safely away from personnel and equipment any significant hydrocarbon flow which cannot be shut-in or controlled.

In the case of the accident on the Zapata Lexington, there was a reluctance to use the diverter because of a fear of collapsing the marine riser. However, riser collapse would not be possible with

the BOP closed. If the crew feared the BOP had failed, then circulation could have been stopped and additional preventers could have been closed to insure that riser collapse would not occur.

Care must also be exercised to remove all sources of ignition, especially when handling gas. Ignition of hydrocarbon often occurs due to careless practices such as cutting, welding, or smoking in hazardous areas.

3.2 Reduction of Gas Flow Rate

The more rapidly gas is produced, the greater will be the hazard of exceeding the capacity of the available gas handling equipment. If a significant pit gain is observed when circulating the riser, several steps could be taken to reduce the gas flow rate from the marine riser. Steps which could be taken using commonly available equipment includes:

1. Reducing the rate at which mud is pumped into the bottom of the marine riser. In some cases the operator lets the gas rise without pumping.
2. Spreading the gas out in the marine riser by pumping mud down the booster line.
3. Spreading the gas out in the marine riser by closing all available preventers for the given pipe size and then opening them one at a time starting at the top of the BOP stack.

3.3 Reduction of Trapped Gas Volume

The larger the volume of gas trapped in the BOP stack, the greater will be the hazard of exceeding the capacity of the available gas handling equipment. A reduction in the trapped gas volume is best accomplished by closing a preventer just above the side outlet which will be used to return mud to the surface via one of the subsea flowlines. In the past, some companies have required that the drill string be hung-off on a ram just above the side outlet being used. However, this safety measure has not been universally accepted because of the risk of sticking the drill string during the well control operations and being faced with a costly fishing job after control of the well is restored. Many operators prefer to use the upper annular preventer whenever weather conditions make it possible so that the risk of stuck pipe is minimized.

A second method for minimizing trapped gas using available equipment is to (1) displace a light liquid such as seawater down one of the subsea flowlines, (2) isolate the gas between two closed preventers, and then (3) releasing the pressure through the subsea flowline. Some accounts of the Zapata Lexington accident indicate that this procedure was used. However, it is difficult to explain the available data if this procedure was correctly applied.

A third method of minimizing trapped gas volume using available equipment is to (1) displace a light fluid such as seawater down one of the subsea flowlines, (2) close a lower set of rams, and then (3) open the annular preventer and attempt to u-tube the gas downward out

of the stack through the subsea flowline. It is believed that this method was attempted prior to the Zapata Lexington accident. As discussed previously, the range of conditions for which this technique will be successful is not known.

A fourth method of minimizing trapped gas volume using available equipment is to (1) isolate the gas between two closed preventers, and (2) remove a portion of the trapped gas by circulating down one subsea flowline to a lowermost BOP stack connection and out an uppermost connection to the surface through the second subsea flowline. This method usually permits only a small portion of the trapped gas to be removed if the well was circulated out using the upper annular preventer.

3.4 MMS Survey of Field Practice

A recent survey was conducted by MMS of all rigs operating in greater than 500 ft of water. For each rig, the procedure for handling trapped gas in a subsea BOP stack was obtained from a lease operator representative. There were 24 rigs operating in water depths ranging from 503 ft to 2191 ft at the time of the survey. Twelve different operating companies were involved. The results of this survey are given in Appendix C.

The survey results are summarized in Table 2. The use of a gumbo box upstream of the shale shaker was not reported for any of the rigs in the survey. All of the rigs were reported to have risers that were rated for collapse to water depths greater than the operating

TABLE 2 - Summary of MMS Survey Results

Operator	No. Rigs	Water Depth Range (ft)	Gumbo Box	Riser Collapse Pressure (psig)	Basic Procedure of Handling Trapped Gas
1 Amerada Hess	1	1004	No	1315	Use diverter
2 Amoco	2	575-1015	No No	1061 1550	Rig 1 - Hang-off to minimize volume Rig 2 - U-tube gas; then use diverter
3 Conoco	1	1680	No	800	U-tube gas
4 Diamond Shamrock	1	1609	No	716	Hang-off to minimize volume Use diverter if gas in riser Let gas rise without pumping
5 Exxon	2	1375-1734	No No	1768 894	Rig 1 - Mud gas separator/diverter Rig 2 - U-tube gas/diverter
6 Marathon	2	757-1295	? No	568 1300	Rig 1 - Mud gas separator/diverter Rig 2 - Hang-off to minimize volume
7 Mobil	2	750-1141	No No	668/1335 1342	Rig 1 - U-tube gas Rig 2 - U-tube gas
8 Odeco	1	1250	No	568/1386	Hang-off to minimize volume
9 Placid	5	1504-2460	No	772/2191	Hang-off to minimize volume
10 Shell	2	1445-1580	No No	? 2146	Rig 1 - Use diverter Rig 2 - Use diverter/let gas rise without pumping
11 Sohio	3	950-1277	No	656	Pump down kill line and up choke line
12 Texaco	2	503-508	No	>630	U-tube gas

water depths.

The procedure proposed for handling gas trapped in the BOP stack varied considerably. The technique of trying to u-tube the gas out of the stack appeared to be quite common. However, the majority of the rigs appeared to be under orders to hang-off the drill pipe and thus minimize the trapped gas volume. A number of rigs were under orders to watch for gas expansion, and to put the flow through a separator if possible, or through the diverter if the available separator capacity was insufficient. Some operators suggested that after opening the annular preventer, one should let the gas migrate to the surface without pumping to minimize the gas flow rates involved, and to minimize the loss of mud when using a diverter.

4. ALTERNATIVE EQUIPMENT DESIGNS

In the previous section of this report, alternative techniques for handling trapped gas in a subsea BOP stack which required only existing equipment were discussed. In this section, the use of additional techniques which could be applied after making appropriate equipment modifications will be presented.

The best way for handling the specific problem under review is to eliminate the possibility of trapping significant volumes of gas in the BOP stack during well control operations. Drilling economics often favor the use of the upper annular BOP in these operations. The upper annular can be pulled and repaired without pulling the entire stack, so wear on this unit due to use is more acceptable. In addition, the use of an annular preventer allows pipe movement during the well control operations and thus reduces the risk of sticking the drill pipe in the borehole. This suggests that provisions should be made for a side outlet to one of the subsea flowlines built into the upper annular preventer. A schematic showing a side outlet arrangement which would eliminate the collection of gas in the BOP stack is shown in Fig. 9.

Additional equipment design changes would also be desirable to increase the capability of safely handling gas which has entered the marine riser in situations other than well control operations. Areas which show promise for potential improvements include:

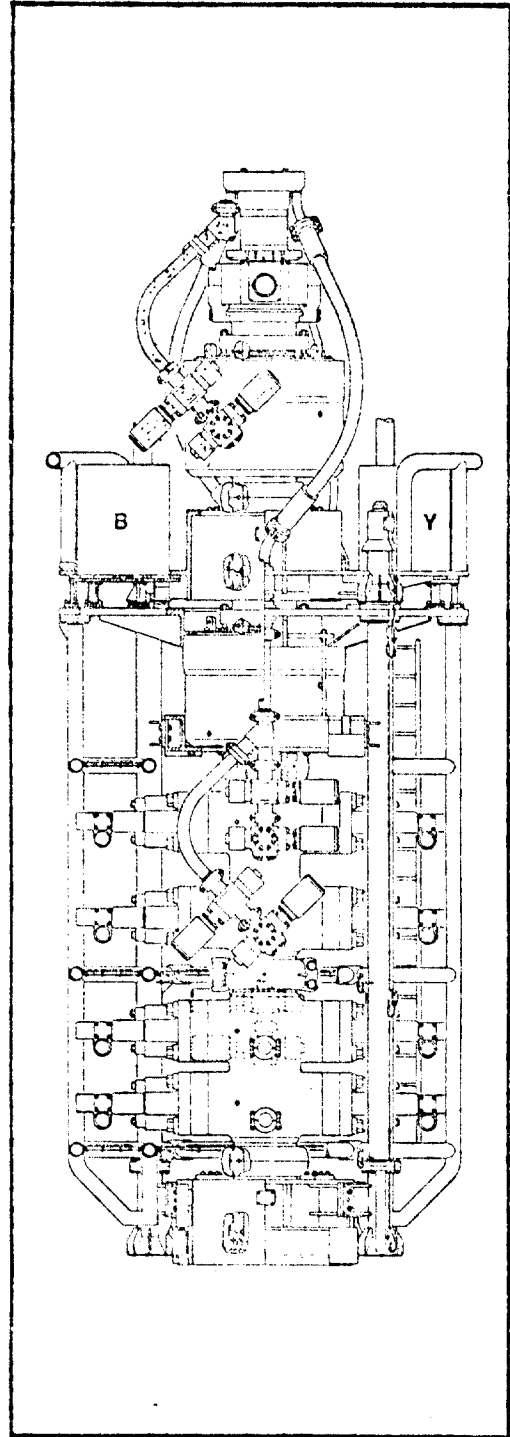
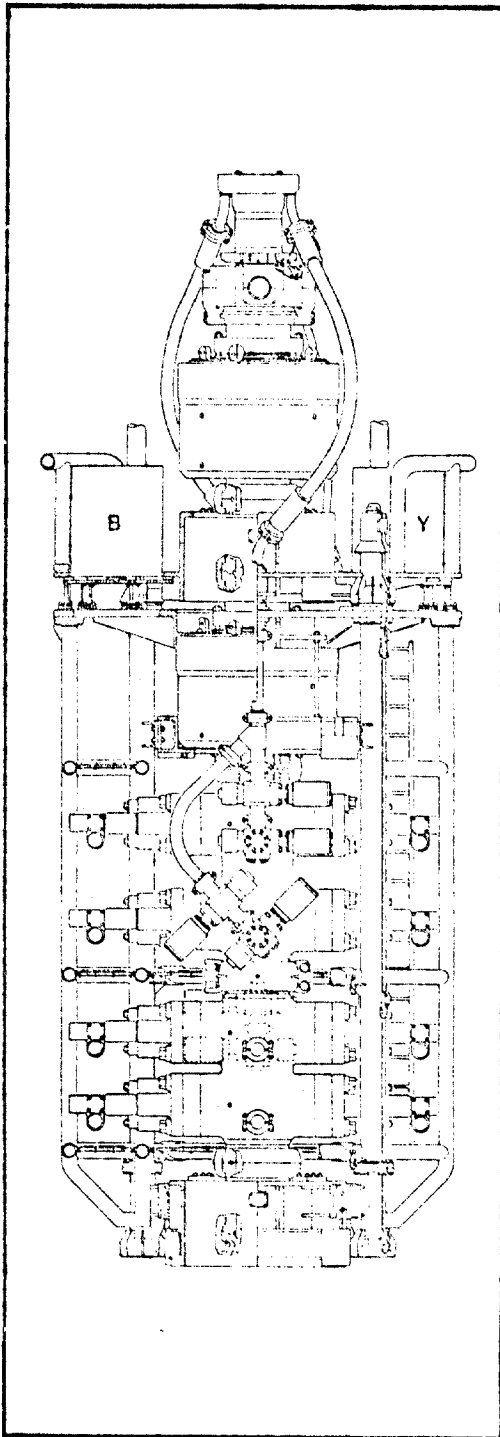

a) Convention Arrangement

b) Proposed Arrangement

FIGURE 9. PROPOSED ADDITION OF SIDE PORT OUTLET TO ANNULAR PREVENTER

- (1) Reviewing the sizing requirements of the mud gas separator equipment.
- (2) The installation of a low pressure choke in the flow path leading to the mud gas separator.
- (3) Designing a flowline degasser specifically for handling gas from a marine riser.
- (4) The installation of a "bubble chopping" device on the marine riser for dispersing the gas in a larger volume of mud.
- (5) Installation of an inert gas system for:
 - (a) Rendering diverted mixtures inflammable.
 - (b) Displacing a subsea flowline to remove hydrostatic pressure on trapped gas.

All of these areas require considerable further study before a definitive recommendation could be made. In some cases considerable re-design work of existing systems would be necessary to add the additional desired feature. Also, the potential benefits must be carefully weighed against the increased complexity of the operation. Many of these areas are currently under investigation in the MMS/LSU research project.

5. IDENTIFICATION OF SIMILAR HAZARDS

The circumstances leading to the accident on the Zapata Lexington are believed to be due to the release of trapped gas to the marine riser during well control operations. However, several other situations can be recognized which could also lead to gas entering the marine riser. Once gas has entered the marine riser, it must be handled at the surface and situations similar to the one at the time of the accident could occur.

The difficulty of detecting a leaking BOP sealing element in a subsea stack has been often addressed. If the blowout preventer leaks during well control operations, a considerable volume of gas can enter the marine riser. The diverter system is generally used to safely handle this possibility. Most operators routinely close the diverter head and open a diverter line when circulating out a kick.

As the search for hydrocarbons is extended to deeper water depths, it becomes more and more difficult to detect a gas kick before it reaches the seafloor. Many operators have begun to develop contingency plans for kicks in which significant volumes of gas are already in the marine riser when the blowout preventers are initially closed. Again, most current plans center around the use of the diverter. However, to prevent a severe loss of mud from the marine riser to the ocean, other possibilities should be explored.

Gas cut mud is a common occurrence in drilling operations. Gas cut mud can be due to gas that was in the rock destroyed by the bit

or it can be due to gas seeping into the borehole from a low permeability formation. Gas seepage is also associated with reductions in bottom hole pressure due to vertical pipe movements. Gas cut mud from gas seepage and pipe movement can be particularly troublesome after a trip to change the bit. This gas is generally called trip gas. Since gas cut mud is circulated to the surface through the marine riser, there is also the potential for an accidental fire. The use of a forced ventilation system is generally sufficient to safely handle gas cut mud. However, a flowline degasser used in conjunction with the diverter head maybe desirable for a severe gas cut mud situation.

6. CONCLUSIONS AND RECOMMENDATIONS

As a result of this accident review, the following conclusions are made:

1. The accident occurring on the Zapata Lexington was caused by gas trapped in the subsea BOP stack during routine well control operations, which was later released to the marine riser.
2. Approximately 5 to 10 bbl of gas would have had to be released to the marine riser to reasonably explain the observed conditions at the time of the accident.
3. The U-tube method attempted to remove the gas trapped in the BOP stack did not succeed.
4. The U-tube procedure followed for removing the trapped gas from the BOP stack is widely used in current practice.
5. If the severity of the situation had been recognized soon enough, alternative procedures could have been used with existing equipment to greatly reduce the hazard.
6. Equipment modifications are desirable to greatly reduce the volume of gas trapped when pumping out a gas kick using the upper annular preventer.

The accident underscored the need for the research on the design and use of diverter systems which is currently underway at LSU. It is recommended that the scope of the research be expanded to permit an experimental study of the U-tube method of removing trapped gas

from a BOP stack. The focus of this research would be to define the conditions for which this method would succeed as well as the conditions for which it would fail.

Appendix A

Simulation of Kick Pump-Out Phase
of Well Control Operations

GAS PROPERTIES PROGRAM

GAS FORMATION PROPERTIES

PERMEABILITY 50
 THICKNESS, FT 5.0
 HC POROSITY 0.150
 EFF COMPRESSIBILITY, PSI-1 0.00004000
 FORMATION TEMPERATURE, DEG F 160.
 GAS SPECIFIC GRAVITY 0.6000
 GAS VISCOSITY, CP 0.0400000
 WELLSURFACTANTS

SURFACE TEMPERATURE, DEG F 100.
 FLOWING TEMP GRAD, DEG F/FT 0.0080
 BOTTOM HOLE TEMPERATURE 176.

MUD PROPERTIES

DENSITY 8.5
 PLAS VISC 187.100FZ
 YIELD PT 10
 K 108.8
 CP 108.8
 1 12.5 22. 0.7931 140.2
 2 13.1 25. 0.7772 140.2

ORBITAL SURFACE GEOMETRY

SEC NO.	IN.	IN.	DEGREES	VERT DEV DEGREES	LENGTH FT	DEPTH FT	CAPACITY BBL/FT
1	0.0	4.276	0.0	0.0	4000.	4000.	0.017760
2	0.0	4.276	0.0000	0.0000	1000.	5000.	0.017760
3	0.0	4.276	25.0000	25.0000	3050.	8050.	0.017760
4	0.0	3.000	25.0000	25.0000	530.	8588.	0.008742
5	0.0	3.000	33.6000	33.6000	742.	9330.	0.008742
6	0.0	2.010	33.6000	33.6000	205.	9535.	0.007670

TRUE VERTICAL DEPTH, FT 9028.

ANNULAR GEOMETRY

SEC NO	DIAMETER IN.	DIAMETER IN.	VERT DEV DEGREES	LENGTH FT	DEPTH FT	CAPACITY BBL/FT
1	1.0	2.375	0.0	1525.	1525.	0.005479
2	5.000	8.681	0.0	2475.	4000.	0.048917
3	5.000	8.681	9.000	1000.	5000.	0.048917
4	5.000	8.681	35.000	3500.	8588.	0.048917
5	5.000	8.375	33.600	500.	9148.	0.070430
6	5.000	8.500	33.600	182.	9330.	0.045896
7	6.500	8.500	33.600	205.	9535.	0.029140

TRUE VERTICAL DEPTH, FT 9028.

BIT NOZZLE AREA, SQ IN 0.4510

WELL PRESSURE LIO. UP
40 050

KICK OFF AND CONCENTRATION 9535.
MEAS. DEPTH, FT 35.0
INITIAL GAIN, BBL 0.050
LIQUID HOLD-UP 15.
GAS SLIP VELOCITY, F/FT 60.
TIME BEFORE CIRCULATION, MIN 1.000
GAS TRANSPORT RATIO

WELL CIRCULATION CONDITIONS
PUMP RATE, BBL/MIN 4.70
ANNULAR CIRC PRESS LOSS, PSIG 444.
ANNULAR SEC 1 PRESS LOSS, PSI 395.

CONSTANT BOTTOM HOLE PRESSURE OPERATION

INITIAL OVERBALANCE, PSI 50.

NO. CELLS 143

Table with 4 columns and 183 rows. The columns contain numerical data. The rows are indexed from 96 to 143. The table is mostly filled with zeros, with some numerical values appearing in the first and third columns.

CELL NO.	DEPTH (FT)	PRESSURE (LBS)	LIQ. WT. (LBS)	LIQ. DEN. (LBS/GAL)	GAS WT. (LBS)	AVG. DEN. (LBS/GAL)	FLOW RATE (GAL/MIN)
40	9535.	6133.	2097.37	12.50	0.0	12.50	4.70
41	9398.	6055.	2097.37	12.50	0.0	12.50	4.70
42	9261.	5977.	2097.37	12.50	0.0	12.50	4.70
43	9124.	5900.	2097.37	12.50	0.0	12.50	4.70
44	9025.	5873.	2097.37	12.50	0.0	12.50	4.70
45	9068.	5873.	2097.37	12.50	0.0	12.50	4.70
46	8931.	5846.	2097.37	12.50	0.0	12.50	4.70
47	8854.	5811.	2097.37	12.50	0.0	12.50	4.70
48	8898.	5780.	2097.37	12.50	0.0	12.50	4.70
49	8841.	5749.	2097.37	12.50	0.0	12.50	4.70
50	8704.	5718.	2097.37	12.50	0.0	12.50	4.70
51	8727.	5667.	2097.37	12.50	0.0	12.50	4.70
52	8671.	5657.	2097.37	12.50	0.0	12.50	4.70
53	8614.	5626.	2097.37	12.50	0.0	12.50	4.70
54	8574.	5595.	2097.37	12.50	0.0	12.50	4.70
55	8524.	5574.	2097.37	12.50	0.0	12.50	4.70
56	8381.	5488.	2097.37	12.50	0.0	12.50	4.70
57	8299.	5439.	2097.37	12.50	0.0	12.50	4.70
58	8247.	5391.	2097.37	12.50	0.0	12.50	4.70
59	8195.	5342.	2097.37	12.50	0.0	12.50	4.70
60	8054.	5294.	2097.37	12.50	0.0	12.50	4.70
61	7972.	5245.	2097.37	12.50	0.0	12.50	4.70
62	7890.	5196.	2097.37	12.50	0.0	12.50	4.70
63	7807.	5147.	2097.37	12.50	0.0	12.50	4.70
64	7727.	5099.	2097.37	12.50	0.0	12.50	4.70
65	7645.	5051.	2097.37	12.50	0.0	12.50	4.70
66	7564.	5002.	2097.37	12.50	0.0	12.50	4.70
67	7482.	4954.	2097.37	12.50	0.0	12.50	4.70
68	7400.	4905.	2097.37	12.50	0.0	12.50	4.70
69	7319.	4856.	2097.37	12.50	0.0	12.50	4.70
70	7237.	4808.	2097.37	12.50	0.0	12.50	4.70
71	7155.	4759.	2097.37	12.50	0.0	12.50	4.70
72	7074.	4711.	2097.37	12.50	0.0	12.50	4.70
73	6992.	4662.	2097.37	12.50	0.0	12.50	4.70
74	6910.	4613.	2097.37	12.50	0.0	12.50	4.70
75	6829.	4565.	2097.37	12.50	0.0	12.50	4.70
76	6747.	4516.	2097.37	12.50	0.0	12.50	4.70
77	6665.	4468.	2097.37	12.50	0.0	12.50	4.70
78	6584.	4419.	2097.37	12.50	0.0	12.50	4.70
79	6502.	4370.	2097.37	12.50	0.0	12.50	4.70
80	6420.	4322.	2097.37	12.50	0.0	12.50	4.70
81	6339.	4273.	2097.37	12.50	0.0	12.50	4.70
82	6257.	4224.	2097.37	12.50	0.0	12.50	4.70
83	6175.	4175.	194.87	12.50	295.10	2.10	4.70
84	6083.	4206.	104.87	12.50	295.19	2.10	4.70
85	5990.	4197.	104.87	12.50	295.29	2.10	4.70
86	5897.	4188.	104.87	12.50	295.39	2.10	4.70
87	5804.	4179.	104.87	12.50	295.50	2.10	4.70
88	5711.	4169.	104.87	12.50	295.60	2.10	4.69
89	5618.	4160.	104.87	12.50	295.70	2.10	4.69
90	5525.	4151.	104.87	12.50	295.80	2.10	4.69
91	5432.	4141.	104.87	12.50	295.91	2.10	4.69
92	5339.	4132.	104.87	12.50	296.01	2.10	4.69
93	5246.	4122.	104.87	12.50	296.12	2.10	4.69
94	5153.	4113.	104.87	12.50	296.22	2.10	4.68

CELL NO. DEPTH (FT) PRESSURE (PSI) LIQ. WT. (LBS) LIQ. DEN. (LBS/GAL) GAS WT. (LBS) GAS DEN. (LBS/GAL) AVG. HT. (FT) AVG. DEN. (LBS/GAL) FLOW RATE (GAL) FLOW RATE (L/MIN)

CELL NO.	DEPTH (FT)	PRESSURE (PSI)	LIQ. WT. (LBS)	LIQ. DEN. (LBS/GAL)	GAS WT. (LBS)	GAS DEN. (LBS/GAL)	AVG. HT. (FT)	AVG. DEN. (LBS/GAL)	FLOW RATE (GAL)	FLOW RATE (L/MIN)
40	9535.	6133.	2097.37	12.50	0.0	0.0	12.50	12.50	4.70	4.70
41	9398.	6055.	2097.37	12.50	0.0	0.0	12.50	12.50	4.70	4.70
42	9261.	5977.	2097.37	12.50	0.0	0.0	12.50	12.50	4.70	4.70
43	9125.	5903.	2097.37	12.50	0.0	0.0	12.50	12.50	4.70	4.70
44	9089.	5873.	2097.37	12.50	0.0	0.0	12.50	12.50	4.70	4.70
45	8952.	5795.	2097.37	12.50	0.0	0.0	12.50	12.50	4.70	4.70
46	8816.	5717.	2097.37	12.50	0.0	0.0	12.50	12.50	4.70	4.70
47	8679.	5639.	2097.37	12.50	0.0	0.0	12.50	12.50	4.70	4.70
48	8543.	5561.	2097.37	12.50	0.0	0.0	12.50	12.50	4.70	4.70
49	8406.	5483.	2097.37	12.50	0.0	0.0	12.50	12.50	4.70	4.70
50	8270.	5405.	2097.37	12.50	0.0	0.0	12.50	12.50	4.70	4.70
51	8133.	5327.	2097.37	12.50	0.0	0.0	12.50	12.50	4.70	4.70
52	7997.	5249.	2097.37	12.50	0.0	0.0	12.50	12.50	4.70	4.70
53	7860.	5171.	2097.37	12.50	0.0	0.0	12.50	12.50	4.70	4.70
54	7724.	5093.	2097.37	12.50	0.0	0.0	12.50	12.50	4.70	4.70
55	7587.	5015.	2097.37	12.50	0.0	0.0	12.50	12.50	4.70	4.70
56	7451.	4937.	2097.37	12.50	0.0	0.0	12.50	12.50	4.70	4.70
57	7314.	4859.	2097.37	12.50	0.0	0.0	12.50	12.50	4.70	4.70
58	7178.	4781.	2097.37	12.50	0.0	0.0	12.50	12.50	4.70	4.70
59	7041.	4703.	2097.37	12.50	0.0	0.0	12.50	12.50	4.70	4.70
60	6905.	4625.	2097.37	12.50	0.0	0.0	12.50	12.50	4.70	4.70
61	6768.	4547.	2097.37	12.50	0.0	0.0	12.50	12.50	4.70	4.70
62	6632.	4469.	2097.37	12.50	0.0	0.0	12.50	12.50	4.70	4.70
63	6495.	4391.	2097.37	12.50	0.0	0.0	12.50	12.50	4.70	4.70
64	6359.	4313.	2097.37	12.50	0.0	0.0	12.50	12.50	4.70	4.70
65	6222.	4235.	2097.37	12.50	0.0	0.0	12.50	12.50	4.70	4.70
66	6086.	4157.	2097.37	12.50	0.0	0.0	12.50	12.50	4.70	4.70
67	5949.	4079.	2097.37	12.50	0.0	0.0	12.50	12.50	4.70	4.70
68	5813.	4001.	2097.37	12.50	0.0	0.0	12.50	12.50	4.70	4.70
69	5676.	3923.	2097.37	12.50	0.0	0.0	12.50	12.50	4.70	4.70
70	5540.	3845.	2097.37	12.50	0.0	0.0	12.50	12.50	4.70	4.70
71	5403.	3767.	2097.37	12.50	0.0	0.0	12.50	12.50	4.70	4.70
72	5267.	3689.	2097.37	12.50	0.0	0.0	12.50	12.50	4.70	4.70
73	5130.	3611.	2097.37	12.50	0.0	0.0	12.50	12.50	4.70	4.70
74	4994.	3533.	2097.37	12.50	0.0	0.0	12.50	12.50	4.70	4.70
75	4857.	3455.	2097.37	12.50	0.0	0.0	12.50	12.50	4.70	4.70
76	4721.	3377.	2097.37	12.50	0.0	0.0	12.50	12.50	4.70	4.70
77	4584.	3299.	2097.37	12.50	0.0	0.0	12.50	12.50	4.70	4.70
78	4448.	3221.	2097.37	12.50	0.0	0.0	12.50	12.50	4.70	4.70
79	4311.	3143.	2097.37	12.50	0.0	0.0	12.50	12.50	4.70	4.70
80	4175.	3065.	2097.37	12.50	0.0	0.0	12.50	12.50	4.70	4.70
81	4038.	2987.	2097.37	12.50	0.0	0.0	12.50	12.50	4.70	4.70
82	3902.	2909.	2097.37	12.50	0.0	0.0	12.50	12.50	4.70	4.70
83	3765.	2831.	2097.37	12.50	0.0	0.0	12.50	12.50	4.70	4.70
84	3629.	2753.	2097.37	12.50	0.0	0.0	12.50	12.50	4.70	4.70
85	3492.	2675.	2097.37	12.50	0.0	0.0	12.50	12.50	4.70	4.70
86	3356.	2597.	2097.37	12.50	0.0	0.0	12.50	12.50	4.70	4.70
87	3219.	2519.	2097.37	12.50	0.0	0.0	12.50	12.50	4.70	4.70
88	3083.	2441.	2097.37	12.50	0.0	0.0	12.50	12.50	4.70	4.70
89	2946.	2363.	2097.37	12.50	0.0	0.0	12.50	12.50	4.70	4.70
90	2810.	2285.	2097.37	12.50	0.0	0.0	12.50	12.50	4.70	4.70
91	2673.	2207.	2097.37	12.50	0.0	0.0	12.50	12.50	4.70	4.70
92	2537.	2129.	2097.37	12.50	0.0	0.0	12.50	12.50	4.70	4.70
93	2400.	2051.	2097.37	12.50	0.0	0.0	12.50	12.50	4.70	4.70
94	2264.	1973.	2097.37	12.50	0.0	0.0	12.50	12.50	4.70	4.70

95	506.1.	4104.	104.87	12.50	297.33	2.10	4.68
96	456.3.	4074.	104.87	12.50	296.13	2.10	4.68
97	487.5.	4084.	104.87	12.50	296.54	2.10	4.68
98	478.2.	4073.	104.87	12.50	296.64	2.10	4.68
99	458.3.	4072.	104.87	12.50	296.75	2.10	4.68
100	459.6.	4053.	104.87	12.50	296.86	2.10	4.68
101	450.3.	4043.	104.87	12.50	296.97	2.10	4.68
102	441.0.	4033.	104.87	12.50	297.07	2.10	4.68
103	431.6.	4023.	104.87	12.50	297.18	2.10	4.68
104	422.3.	4012.	104.87	12.50	297.29	2.10	4.68
105	413.0.	3976.	1307.43	12.50	117.91	8.03	4.69
106	404.4.	3923.	2097.37	12.50	0.0	12.50	4.69
107	395.7.	3870.	2097.37	12.50	0.0	12.50	4.69
108	387.1.	3816.	2097.37	12.50	0.0	12.50	4.69
109	379.9.	3763.	2097.37	12.50	0.0	12.50	4.69
110	371.7.	3709.	2097.37	12.50	0.0	12.50	4.69
111	363.5.	3656.	2097.37	12.50	0.0	12.50	4.69
112	355.4.	3602.	2097.37	12.50	0.0	12.50	4.69
113	347.2.	3548.	2097.37	12.50	0.0	12.50	4.69
114	339.0.	3495.	2097.37	12.50	0.0	12.50	4.69
115	330.8.	3441.	2097.37	12.50	0.0	12.50	4.69
116	322.7.	3388.	2097.37	12.50	0.0	12.50	4.69
117	314.5.	3334.	2097.37	12.50	0.0	12.50	4.69
118	306.4.	3281.	2097.37	12.50	0.0	12.50	4.69
119	298.2.	3227.	2097.37	12.50	0.0	12.50	4.69
120	290.1.	3175.	2097.37	12.50	0.0	12.50	4.69
121	281.9.	3120.	2097.37	12.50	0.0	12.50	4.69
122	273.7.	3066.	2097.37	12.50	0.0	12.50	4.69
123	265.5.	3013.	2097.37	12.50	0.0	12.50	4.69
124	257.4.	2959.	2097.37	12.50	0.0	12.50	4.69
125	249.2.	2906.	2097.37	12.50	0.0	12.50	4.69
126	241.0.	2852.	2097.37	12.50	0.0	12.50	4.69
127	232.8.	2798.	2097.37	12.50	0.0	12.50	4.69
128	224.7.	2745.	2097.37	12.50	0.0	12.50	4.69
129	216.5.	2691.	2097.37	12.50	0.0	12.50	4.69
130	208.4.	2638.	2097.37	12.50	0.0	12.50	4.69
131	200.2.	2584.	2097.37	12.50	0.0	12.50	4.69
132	192.0.	2531.	2097.37	12.50	0.0	12.50	4.69
133	183.9.	2477.	2097.37	12.50	0.0	12.50	4.69
134	175.7.	2424.	2097.37	12.50	0.0	12.50	4.69
135	167.5.	2370.	2097.37	12.50	0.0	12.50	4.69
136	159.4.	2316.	2097.37	12.50	0.0	12.50	4.69
137	151.0.	2261.	2097.37	12.50	0.0	12.50	4.69
138	681.	1500.	1957.78	12.50	0.0	12.50	4.69
139	0.	0.	0.	0.	0.	0.	4.68

MIN BBL VOLUME BBL GAS 100 DP PIES MA TOUT AV PIES GAS FLON
 BBL PSIA PSIA PSIA PSIA PSIA SCF70

28.5	113.8	7.4	4085.	572.	4.686	1066.	0.
26.3	123.8	98.0	4000.	565.	4.688	1048.	0.
27.2	127.8	98.7	3905.	559.	4.690	1030.	0.
28.0	131.8	99.4	3809.	553.	4.693	1010.	0.
28.9	135.8	100.1	3713.	547.	4.695	990.	0.
29.7	139.8	100.8	3617.	541.	4.698	970.	0.
30.6	143.8	101.6	3519.	535.	4.701	1136.	0.
31.4	147.8	102.3	3422.	525.	4.704	1114.	0.
32.3	151.8	103.1	3325.	515.	4.707	1090.	0.
33.1	155.8	104.0	3225.	517.	4.710	1065.	0.
34.0	159.8	104.9	3125.	517.	4.714	1036.	0.
34.8	163.8	105.8	3024.	517.	4.718	1193.	0.
35.7	167.8	106.6	2924.	517.	4.722	1159.	0.
36.5	171.8	107.5	2819.	517.	4.726	1126.	0.
37.4	175.8	108.9	2715.	517.	4.729	1092.	0.
38.2	179.8	110.0	2612.	517.	4.732	1245.	0.
39.1	183.8	111.2	2506.	517.	4.735	1203.	0.
39.9	187.8	112.4	2399.	517.	4.738	1159.	0.
40.8	191.8	113.8	2290.	517.	4.744	1159.	0.
41.6	195.8	115.1	2180.	517.	4.751	1303.	0.
42.5	199.7	116.6	2069.	517.	4.758	1254.	0.
43.3	203.7	118.1	1957.	517.	4.766	1202.	0.
44.2	207.7	119.6	1843.	517.	4.774	1341.	0.
45.0	211.7	121.3	1727.	517.	4.784	1284.	0.
45.9	215.7	123.1	1609.	517.	4.793	1417.	0.
46.7	219.7	125.0	1497.	517.	4.803	1352.	0.
47.6	223.7	126.2	1380.	517.	4.809	1475.	0.
48.4	227.7	126.7	1267.	517.	4.795	2146.	0.
49.2	231.7	119.9	1150.	517.	4.803	2379.	0.
50.1	235.7	116.1	1030.	517.	4.810	2321.	0.
			0.			2289.	0.

95	3198	2097.37	12.50	0.0	4.70
96	5114	2097.37	12.50	0.0	4.70
97	5032	2097.37	12.50	0.0	4.70
98	4950	2097.37	12.50	0.0	4.70
99	4868	2097.37	12.50	0.0	4.70
100	4787	2097.37	12.50	0.0	4.70
101	4705	2097.37	12.50	0.0	4.70
102	4624	2097.37	12.50	0.0	4.70
103	4542	2097.37	12.50	0.0	4.70
104	4460	2097.37	12.50	0.0	4.70
105	4379	2097.37	12.50	0.0	4.70
106	4297	2097.37	12.50	0.0	4.70
107	4215	2097.37	12.50	0.0	4.70
108	4134	2097.37	12.50	0.0	4.70
109	4052	2097.37	12.50	0.0	4.70
110	3970	2097.37	12.50	0.0	4.70
111	3889	2097.37	12.50	0.0	4.70
112	3807	2097.37	12.50	0.0	4.70
113	3725	104.87	12.50	295.10	4.71
114	3598	104.87	12.50	295.19	4.72
115	3471	104.87	12.50	295.28	4.73
116	3344	104.87	12.50	295.37	4.74
117	3217	104.87	12.50	295.50	4.75
118	3090	104.87	12.50	295.60	4.76
119	2962	104.87	12.50	295.78	4.77
120	2835	104.87	12.50	295.80	4.78
121	2707	104.87	12.50	295.91	4.79
122	2579	104.87	12.50	296.01	4.80
123	2452	104.87	12.50	296.12	4.81
124	2322	104.87	12.50	296.22	4.82
125	2194	104.87	12.50	296.33	4.83
126	2065	104.87	12.50	296.43	4.84
127	1936	104.87	12.50	296.54	4.85
128	1807	104.87	12.50	296.64	4.86
129	1678	104.87	12.50	296.75	4.87
130	1549	104.87	12.50	296.86	4.88
131	1420	51.29	12.50	145.23	4.89
132	2200	0.0	0.0	0.0	4.90

ME	MO	W	AS	BP	DR	PSIA	PSIA	AH	PPSS	GAS	FLOW
n.	BBL	BBL	FT	PP	PSIA	PSIA	PSIA	PSIA	PSIA	SCF/D	SCF/D
51.0	230.7	110.3	0.	0.	517.	517.	2248.	0.	0.	0.	0.
51.8	243.7	108.5	0.	0.	517.	517.	2209.	0.	0.	0.	0.
52.7	247.7	104.7	0.	0.	517.	517.	2170.	0.	0.	0.	0.
53.5	251.7	100.9	0.	0.	517.	517.	2133.	0.	0.	0.	0.
54.4	255.7	97.1	0.	0.	517.	517.	2097.	0.	0.	0.	0.
55.2	259.7	93.2	0.	0.	517.	517.	2063.	0.	0.	0.	0.
56.1	263.7	89.4	0.	0.	517.	517.	2047.	0.	0.	0.	0.
56.9	267.7	85.6	0.	0.	517.	517.	1921.	0.	0.	0.	0.
57.8	271.7	81.8	0.	0.	517.	517.	1893.	0.	0.	0.	0.
58.6	275.7	77.9	0.	0.	517.	517.	1865.	0.	0.	0.	0.
59.5	279.6	74.1	0.	0.	517.	517.	1838.	0.	0.	0.	0.
60.3	283.6	70.2	36.	0.	517.	517.	1813.	0.	0.	0.	0.
61.2	287.6	66.4	0.	0.	517.	517.	1740.	0.	0.	0.	0.
62.0	291.6	62.5	0.	0.	517.	517.	1692.	0.	0.	0.	0.
62.9	295.6	58.7	0.	0.	517.	517.	1673.	0.	0.	0.	0.
63.7	299.6	54.8	0.	0.	517.	517.	1672.	0.	0.	0.	0.
64.6	303.6	50.9	0.	0.	517.	517.	1552.	0.	0.	0.	0.
65.4	307.6	47.1	0.	0.	517.	517.	1458.	0.	0.	0.	0.
66.3	311.6	43.2	0.	0.	517.	517.	1459.	0.	0.	0.	0.
67.1	315.6	39.3	0.	0.	517.	517.	1438.	0.	0.	0.	0.
68.0	319.6	35.4	0.	0.	517.	517.	1358.	0.	0.	0.	0.
68.8	323.6	31.5	0.	0.	517.	517.	1342.	0.	0.	0.	0.
69.7	327.6	27.6	0.	0.	517.	517.	1269.	0.	0.	0.	0.
70.5	331.6	23.7	0.	0.	517.	517.	1243.	0.	0.	0.	0.
71.4	335.6	19.8	0.	0.	517.	517.	1180.	0.	0.	0.	0.
72.2	339.6	15.9	0.	0.	517.	517.	1109.	0.	0.	0.	0.
73.1	343.6	12.0	0.	0.	517.	517.	1095.	0.	0.	0.	0.
73.9	347.6	8.0	0.	0.	517.	517.	1019.	0.	0.	0.	0.
74.8	351.6	4.1	0.	0.	517.	517.	539.	0.	0.	0.	0.
75.6	355.6	0.1	0.	0.	517.	517.	192.	0.	0.	0.	0.

WATER 55331

CELL DEPTH (FT) LIQ. WT. (LBS) LIQ. DEN. (LBS/GAL) GAS WT. (LBS) DEN. (LBS/GAL) AVG. DEN. (LBS/GAL) FLOW RATE (GAL/MIN)

40	9535	6133	2198.05	13.10	0.0	13.10	4.70
41	9398	6051	2198.05	13.10	0.0	13.10	4.70
42	9261	5985	2198.05	13.10	0.0	13.10	4.70
43	9199	5934	2198.05	13.10	0.0	13.10	4.70
44	9125	5892	2198.05	13.10	0.0	13.10	4.70
45	9068	5859	2198.05	13.10	0.0	13.10	4.70
46	9011	5827	2198.05	13.10	0.0	13.10	4.70
47	8954	5795	2198.05	13.10	0.0	13.10	4.70
48	8898	5762	2198.05	13.10	0.0	13.10	4.70
49	8841	5730	2198.05	13.10	0.0	13.10	4.70
50	8784	5698	2198.05	13.10	0.0	13.10	4.70
51	8727	5665	2198.05	13.10	0.0	13.10	4.70
52	8671	5633	2198.05	13.10	0.0	13.10	4.70
53	8614	5600	2198.05	13.10	0.0	13.10	4.70
54	8557	5568	2198.05	13.10	0.0	13.10	4.70
55	8500	5535	2198.05	13.10	0.0	13.10	4.70
56	8443	5502	2198.05	13.10	0.0	13.10	4.70
57	8386	5469	2198.05	13.10	0.0	13.10	4.70
58	8329	5436	2198.05	13.10	0.0	13.10	4.70
59	8272	5403	2198.05	13.10	0.0	13.10	4.70
60	8215	5370	2198.05	13.10	0.0	13.10	4.70
61	8158	5337	2198.05	13.10	0.0	13.10	4.70
62	8101	5304	2198.05	13.10	0.0	13.10	4.70
63	8044	5271	2198.05	13.10	0.0	13.10	4.70
64	7987	5238	2198.05	13.10	0.0	13.10	4.70
65	7930	5205	2198.05	13.10	0.0	13.10	4.70
66	7873	5172	2198.05	13.10	0.0	13.10	4.70
67	7816	5139	2198.05	13.10	0.0	13.10	4.70
68	7759	5106	2198.05	13.10	0.0	13.10	4.70
69	7702	5073	2198.05	13.10	0.0	13.10	4.70
70	7645	5040	2198.05	13.10	0.0	13.10	4.70
71	7588	5007	2198.05	13.10	0.0	13.10	4.70
72	7531	4974	2198.05	13.10	0.0	13.10	4.70
73	7474	4941	2198.05	13.10	0.0	13.10	4.70
74	7417	4908	2198.05	13.10	0.0	13.10	4.70
75	7360	4875	2198.05	13.10	0.0	13.10	4.70
76	7303	4842	2198.05	13.10	0.0	13.10	4.70
77	7246	4809	2198.05	13.10	0.0	13.10	4.70
78	7189	4776	2198.05	13.10	0.0	13.10	4.70
79	7132	4743	2198.05	13.10	0.0	13.10	4.70
80	7075	4710	2198.05	13.10	0.0	13.10	4.70
81	7018	4677	2198.05	13.10	0.0	13.10	4.70
82	6961	4644	2198.05	13.10	0.0	13.10	4.70
83	6904	4611	2198.05	13.10	0.0	13.10	4.70
84	6847	4578	2198.05	13.10	0.0	13.10	4.70
85	6790	4545	2198.05	13.10	0.0	13.10	4.70
86	6733	4512	2198.05	13.10	0.0	13.10	4.70
87	6676	4479	2198.05	13.10	0.0	13.10	4.70
88	6619	4446	2198.05	13.10	0.0	13.10	4.70
89	6562	4413	2198.05	13.10	0.0	13.10	4.70
90	6505	4380	2198.05	13.10	0.0	13.10	4.70
91	6448	4347	2198.05	13.10	0.0	13.10	4.70
92	6391	4314	2198.05	13.10	0.0	13.10	4.70
93	6334	4281	2198.05	13.10	0.0	13.10	4.70
94	6277	4248	2198.05	13.10	0.0	13.10	4.70
95	6220	4215	2198.05	13.10	0.0	13.10	4.70
96	6163	4182	2198.05	13.10	0.0	13.10	4.70
97	6106	4149	2198.05	13.10	0.0	13.10	4.70
98	6049	4116	2198.05	13.10	0.0	13.10	4.70
99	5992	4083	2198.05	13.10	0.0	13.10	4.70
100	5935	4050	2198.05	13.10	0.0	13.10	4.70

56	5114.	2097.37	12.50	4.70
57	5032.	2097.37	12.50	4.70
98	4950.	2097.37	12.50	4.70
99	4868.	2097.37	12.50	4.70
100	4787.	2097.37	12.50	4.70
101	4705.	2097.37	12.50	4.70
102	4624.	2097.37	12.50	4.70
103	4542.	2097.37	12.50	4.70
104	4460.	2097.37	12.50	4.70
105	4379.	2097.37	12.50	4.70
106	4297.	2097.37	12.50	4.70
107	4215.	2097.37	12.50	4.70
108	4134.	2097.37	12.50	4.70
109	4052.	2097.37	12.50	4.70
110	3970.	2097.37	12.50	4.70
111	3889.	2097.37	12.50	4.70
112	3807.	2097.37	12.50	4.70
113	3725.	2097.37	12.50	4.70
114	3644.	2097.37	12.50	4.70
115	3562.	2097.37	12.50	4.70
116	3480.	2097.37	12.50	4.70
117	3399.	2097.37	12.50	4.70
118	3317.	2097.37	12.50	4.70
119	3235.	2097.37	12.50	4.70
120	3154.	2097.37	12.50	4.70
121	3072.	2097.37	12.50	4.70
122	2990.	2097.37	12.50	4.70
123	2909.	2097.37	12.50	4.70
124	2827.	2097.37	12.50	4.70
125	2745.	2097.37	12.50	4.70
126	2664.	2097.37	12.50	4.70
127	2582.	2097.37	12.50	4.70
128	2500.	2097.37	12.50	4.70
129	2419.	2097.37	12.50	4.70
130	2337.	2097.37	12.50	4.70
131	2255.	2097.37	12.50	4.70
132	2174.	2097.37	12.50	4.70
133	2092.	2097.37	12.50	4.70
134	2010.	2097.37	12.50	4.70
135	1929.	2097.37	12.50	4.70
136	1847.	2097.37	12.50	4.70
137	1765.	2097.37	12.50	4.70
138	1684.	2097.37	12.50	4.70
139	1602.	2097.37	12.50	4.70
140	1520.	2097.37	12.50	4.70
141	1438.	2097.37	12.50	4.70
142	1356.	2097.37	12.50	4.70
143	1274.	2097.37	12.50	4.70

APPENDIX B

Simulation of Circulating Kill Mud
in the Marine Riser

GAS I K CIRCULATION COMPUTER PROGRAM

GAS FORMATION PROPERTIES

PERMEABILITY, MD 0.0
 THICKNESS, FT 0.0
 HC POROSITY 0.001
 EFF COMPRESSIBILITY, PSI-1 0.00010000
 FORMATION PRESSURE, PSIA 1000.
 FORMATION TEMPERATURE, DEG F 60.
 GAS SPECIFIC GRAVITY 0.6000
 GAS VISCOSITY, CP 0.0100000
 WELL BORE RADIUS, FT 0.8333

SURFACE TEMPERATURE, DEG F 60.
 FLOWING TEMP GRAD, DEG F/FT 0.0000
 BOTTOM HOLE TEMP, DEG F 60.

MUD PROPERTIES

DENSITY 8.0
 PPG 12.5
 CP 22.
 PLAS VIS 25.
 YIELD PT, N 10.
 LB/100F2 0.7931
 EQ CP 108.8
 K 140.2

DRILL STRING GEOMETRY

SEC NO. 1
 DIAMETERS IN. 0.0
 IN. 2.375
 VERT DEV DEGREES 0.0
 LENGTH FT 1525.
 DEPTH FT 1525.
 CAPACITY BBL/FT 0.005479
 TRUE VERTICAL DEPTH, FT 1525.

ANNULAR GEOMETRY

SEC NO. 1
 DI- IN. 5.000
 D2- IN. 20.000
 VERT DEV DEGREES 0.0
 LENGTH FT 1525.
 DEPTH FT 1525.
 CAPACITY BBL/FT 0.364256
 TRUE VERTICAL DEPTH, FT 1525.

BIT NOZZLE AREA, SQ IN 1.5000

KICK SIZE AND CONCENTRATION

MEASURED DEPTH, FT 1525.
INITIAL GAIN, BBL 10.4
LIQUID HOLD-UP 0.700
GAS SLIP VELOCITY, FT/M 0.
TIME BEFORE CIRCULATION, MIN 0.
GAS TRANSPORT RATIO 1.000

WELL CIRCULATION CONDITIONS

PUMP RATE, BBL/MIN 4.70
ANNULAR CIRC PRESS LOSS, PSIG 0.
ANNULAR SEC 1 PRESS LOSS, PSI 0.

SURFACE CASING PRESSURE, PSIA 15.

INITIAL OVERBALANCE, PSI 0.

NO. CELLS 136

VOLUN. PUMPED = 0.0 BBL

CELL NO.	DEPTH (FT)	PRESSURE PSIA	LIQ. WT. (LBS)	LIQ. DEN. (LBS/GAL)	GAS WT. (LBS)	AVG. DEN. (LBS/GAL)	FLW RATE BBL/MIN
3	1525.	1000.	1535.32	12.50	26.12	8.90	0.0
4	1514.	995.	1535.32	12.50	25.96	8.90	0.0
5	1502.	989.	1535.32	12.50	25.80	8.90	0.0
6	1491.	984.	1535.32	12.50	25.64	8.90	0.0
7	1479.	979.	1535.32	12.50	25.48	8.90	0.0
8	1468.	973.	1535.32	12.50	25.32	8.89	0.0
9	1456.	968.	1535.32	12.50	25.16	8.89	0.0
10	1445.	963.	1535.32	12.50	25.00	8.89	0.0
11	1433.	958.	1535.32	12.50	24.84	8.89	0.0
12	1422.	951.	1535.32	12.50	24.68	8.89	0.0
13	1410.	943.	1535.32	12.50	24.52	8.89	0.0
14	1399.	936.	1535.32	12.50	24.36	8.89	0.0
15	1387.	928.	1535.32	12.50	24.20	8.89	0.0
16	1376.	921.	1535.32	12.50	24.04	8.89	0.0
17	1364.	913.	1535.32	12.50	23.88	8.89	0.0
18	1353.	906.	1535.32	12.50	23.72	8.89	0.0
19	1341.	899.	1535.32	12.50	23.56	8.89	0.0
20	1330.	891.	1535.32	12.50	23.40	8.89	0.0
21	1319.	884.	1535.32	12.50	23.24	8.89	0.0
22	1307.	876.	1535.32	12.50	23.08	8.89	0.0
23	1296.	869.	1535.32	12.50	22.92	8.89	0.0
24	1284.	861.	1535.32	12.50	22.76	8.89	0.0
25	1273.	854.	1535.32	12.50	22.60	8.89	0.0
26	1261.	846.	1535.32	12.50	22.44	8.89	0.0
27	1250.	839.	1535.32	12.50	22.28	8.89	0.0
28	1238.	831.	1535.32	12.50	22.12	8.89	0.0
29	1227.	824.	1535.32	12.50	21.96	8.89	0.0
30	1215.	817.	1535.32	12.50	21.80	8.89	0.0
31	1204.	809.	1535.32	12.50	21.64	8.89	0.0
32	1192.	802.	1535.32	12.50	21.48	8.89	0.0
33	1181.	794.	1535.32	12.50	21.32	8.89	0.0
34	1169.	787.	1535.32	12.50	21.16	8.89	0.0
35	1158.	779.	1535.32	12.50	21.00	8.89	0.0
36	1146.	772.	1535.32	12.50	20.84	8.89	0.0
37	1135.	764.	1535.32	12.50	20.68	8.89	0.0
38	1124.	757.	1535.32	12.50	20.52	8.89	0.0
39	1112.	749.	1535.32	12.50	20.36	8.89	0.0
40	1101.	742.	1535.32	12.50	20.20	8.89	0.0
41	1089.	735.	1535.32	12.50	20.04	8.89	0.0
42	1078.	727.	1535.32	12.50	19.88	8.89	0.0
43	1066.	720.	1535.32	12.50	19.72	8.89	0.0
44	1055.	712.	1535.32	12.50	19.56	8.89	0.0
45	1043.	705.	1535.32	12.50	19.40	8.89	0.0
46	1032.	697.	1535.32	12.50	19.24	8.89	0.0
47	1020.	690.	1535.32	12.50	19.08	8.89	0.0
48	1009.	682.	1535.32	12.50	18.92	8.89	0.0
49	997.	675.	1535.32	12.50	18.76	8.89	0.0
50	986.	667.	1535.32	12.50	18.60	8.89	0.0
51	974.	660.	1535.32	12.50	18.44	8.89	0.0
52	963.	653.	1535.32	12.50	18.28	8.89	0.0
53	952.	645.	1535.32	12.50	18.12	8.89	0.0
54	940.	638.	1535.32	12.50	17.96	8.89	0.0
55	929.	630.	1535.32	12.50	17.80	8.89	0.0
56	917.	623.	1535.32	12.50	17.64	8.89	0.0
57	905.	615.	1535.32	12.50	17.48	8.89	0.0

58	394.	608.	2193.	193.	32	12.	50	0.	0.	0.	0.
59	883.	600.	2193.	193.	32	12.	50	0.	0.	0.	0.
60	871.	593.	2193.	193.	32	12.	50	0.	0.	0.	0.
61	860.	585.	2193.	193.	32	12.	50	0.	0.	0.	0.
62	848.	578.	2193.	193.	32	12.	50	0.	0.	0.	0.
63	837.	571.	2193.	193.	32	12.	50	0.	0.	0.	0.
64	825.	563.	2193.	193.	32	12.	50	0.	0.	0.	0.
65	814.	556.	2193.	193.	32	12.	50	0.	0.	0.	0.
66	802.	548.	2193.	193.	32	12.	50	0.	0.	0.	0.
67	791.	541.	2193.	193.	32	12.	50	0.	0.	0.	0.
68	779.	533.	2193.	193.	32	12.	50	0.	0.	0.	0.
69	768.	526.	2193.	193.	32	12.	50	0.	0.	0.	0.
70	757.	518.	2193.	193.	32	12.	50	0.	0.	0.	0.
71	745.	511.	2193.	193.	32	12.	50	0.	0.	0.	0.
72	734.	503.	2193.	193.	32	12.	50	0.	0.	0.	0.
73	722.	496.	2193.	193.	32	12.	50	0.	0.	0.	0.
74	711.	488.	2193.	193.	32	12.	50	0.	0.	0.	0.
75	700.	481.	2193.	193.	32	12.	50	0.	0.	0.	0.
76	688.	474.	2193.	193.	32	12.	50	0.	0.	0.	0.
77	676.	466.	2193.	193.	32	12.	50	0.	0.	0.	0.
78	665.	459.	2193.	193.	32	12.	50	0.	0.	0.	0.
79	653.	451.	2193.	193.	32	12.	50	0.	0.	0.	0.
80	642.	444.	2193.	193.	32	12.	50	0.	0.	0.	0.
81	630.	436.	2193.	193.	32	12.	50	0.	0.	0.	0.
82	619.	429.	2193.	193.	32	12.	50	0.	0.	0.	0.
83	607.	421.	2193.	193.	32	12.	50	0.	0.	0.	0.
84	596.	414.	2193.	193.	32	12.	50	0.	0.	0.	0.
85	584.	406.	2193.	193.	32	12.	50	0.	0.	0.	0.
86	573.	399.	2193.	193.	32	12.	50	0.	0.	0.	0.
87	562.	392.	2193.	193.	32	12.	50	0.	0.	0.	0.
88	550.	384.	2193.	193.	32	12.	50	0.	0.	0.	0.
89	539.	377.	2193.	193.	32	12.	50	0.	0.	0.	0.
90	527.	369.	2193.	193.	32	12.	50	0.	0.	0.	0.
91	516.	362.	2193.	193.	32	12.	50	0.	0.	0.	0.
92	504.	354.	2193.	193.	32	12.	50	0.	0.	0.	0.
93	493.	347.	2193.	193.	32	12.	50	0.	0.	0.	0.
94	481.	339.	2193.	193.	32	12.	50	0.	0.	0.	0.
95	470.	332.	2193.	193.	32	12.	50	0.	0.	0.	0.
96	458.	324.	2193.	193.	32	12.	50	0.	0.	0.	0.
97	447.	317.	2193.	193.	32	12.	50	0.	0.	0.	0.
98	435.	310.	2193.	193.	32	12.	50	0.	0.	0.	0.
99	424.	302.	2193.	193.	32	12.	50	0.	0.	0.	0.
100	412.	295.	2193.	193.	32	12.	50	0.	0.	0.	0.
101	401.	287.	2193.	193.	32	12.	50	0.	0.	0.	0.
102	389.	280.	2193.	193.	32	12.	50	0.	0.	0.	0.
103	378.	272.	2193.	193.	32	12.	50	0.	0.	0.	0.
104	367.	265.	2193.	193.	32	12.	50	0.	0.	0.	0.
105	355.	257.	2193.	193.	32	12.	50	0.	0.	0.	0.
106	344.	250.	2193.	193.	32	12.	50	0.	0.	0.	0.
107	332.	242.	2193.	193.	32	12.	50	0.	0.	0.	0.
108	321.	235.	2193.	193.	32	12.	50	0.	0.	0.	0.
109	309.	228.	2193.	193.	32	12.	50	0.	0.	0.	0.
110	298.	220.	2193.	193.	32	12.	50	0.	0.	0.	0.
111	286.	213.	2193.	193.	32	12.	50	0.	0.	0.	0.
112	275.	205.	2193.	193.	32	12.	50	0.	0.	0.	0.
113	263.	198.	2193.	193.	32	12.	50	0.	0.	0.	0.
114	252.	190.	2193.	193.	32	12.	50	0.	0.	0.	0.
115	240.	183.	2193.	193.	32	12.	50	0.	0.	0.	0.
116	229.	175.	2193.	193.	32	12.	50	0.	0.	0.	0.
117	217.	168.	2193.	193.	32	12.	50	0.	0.	0.	0.
118	206.	160.	2193.	193.	32	12.	50	0.	0.	0.	0.

119	195.	153.	2193.32	12.50	0.0	12.50	0.0
120	183.	146.	2193.32	12.50	0.0	12.50	0.0
121	172.	138.	2193.32	12.50	0.0	12.50	0.0
122	160.	131.	2193.32	12.50	0.0	12.50	0.0
123	149.	123.	2193.32	12.50	0.0	12.50	0.0
124	137.	116.	2193.32	12.50	0.0	12.50	0.0
125	126.	108.	2193.32	12.50	0.0	12.50	0.0
126	114.	101.	2193.32	12.50	0.0	12.50	0.0
127	103.	93.	2193.32	12.50	0.0	12.50	0.0
128	91.	86.	2193.32	12.50	0.0	12.50	0.0
129	80.	78.	2193.32	12.50	0.0	12.50	0.0
130	68.	71.	2193.32	12.50	0.0	12.50	0.0
131	57.	64.	2193.32	12.50	0.0	12.50	0.0
132	45.	56.	2193.32	12.50	0.0	12.50	0.0
133	34.	49.	2193.32	12.50	0.0	12.50	0.0
134	22.	41.	2193.32	12.50	0.0	12.50	0.0
135	11.	34.	2105.46	12.50	0.0	12.50	0.0
136	0.	27.	0.0	0.0	0.0	0.0	0.0

TIME MIN.	VOLUME BBL	GAIN BBL	GAS TOP FT	DP PRES PSIA	JD CUT BBL/MIN	AN PRES PSIA	GAS FLOW SCF/D.
0.0	0.0	10.4	1432.	9.	4.700	1000.	0.
0.0	0.0	10.4	1432.	412.	4.700	989.	0.
0.9	4.2	10.6	1420.	401.	4.776	988.	0.
1.7	8.4	10.7	1408.	391.	4.777	988.	0.
2.7	12.5	10.8	1385.	391.	4.779	988.	0.
3.6	16.7	10.9	1373.	391.	4.780	988.	0.
4.4	20.9	11.0	1361.	391.	4.781	989.	0.
5.3	25.1	11.1	1350.	391.	4.783	989.	0.
6.2	29.2	11.2	1338.	391.	4.784	989.	0.
7.1	33.4	11.3	1326.	392.	4.785	989.	0.
8.0	37.6	11.4	1314.	392.	4.787	989.	0.
8.9	41.8	11.6	1303.	392.	4.789	989.	0.
9.8	46.0	11.7	1291.	392.	4.790	990.	0.
10.7	50.1	11.8	1279.	392.	4.792	990.	0.
11.6	54.3	11.9	1267.	393.	4.794	990.	0.
12.4	58.5	12.0	1255.	393.	4.796	990.	0.
13.3	62.7	12.1	1244.	393.	4.797	990.	0.
14.2	66.8	12.3	1232.	393.	4.799	990.	0.
15.1	71.0	12.4	1220.	393.	4.801	990.	0.
16.0	75.2	12.5	1208.	393.	4.803	990.	0.
16.9	79.4	12.7	1196.	393.	4.805	991.	0.
17.8	83.6	12.8	1184.	393.	4.807	991.	0.
18.7	87.7	12.9	1173.	393.	4.809	991.	0.
19.6	91.9	13.1	1161.	394.	4.812	991.	0.
20.4	96.1	13.2	1149.	394.	4.814	991.	0.
21.3	100.3	13.4	1137.	394.	4.816	991.	0.
22.2	104.4	13.5	1125.	394.	4.818	991.	0.
23.0	108.6	13.7	1113.	394.	4.821	991.	0.
24.0	112.8	13.8	1101.	394.	4.823	991.	0.
24.9	117.0	14.0	1089.	394.	4.826	991.	0.
25.8	121.2	14.2	1077.	394.	4.829	991.	0.
26.7	125.3	14.3	1065.	394.	4.831	992.	0.
27.6	129.5	14.5	1053.	394.	4.834	992.	0.
28.4	133.7	14.7	1041.	394.	4.837	992.	0.
29.3	137.9	14.9	1029.	394.	4.840	992.	0.
30.2	142.0	15.0	1017.	394.	4.843	992.	0.
31.1	146.2	15.2	1005.	394.	4.846	992.	0.
32.0	150.4	15.4	993.	394.	4.850	992.	0.
33.8	154.6	15.6	981.	394.	4.853	992.	0.
34.7	158.8	15.8	969.	394.	4.857	992.	0.
35.6	162.9	16.0	957.	394.	4.860	992.	0.
36.4	167.1	16.2	945.	394.	4.864	992.	0.
37.3	171.3	16.5	933.	394.	4.868	992.	0.
38.2	175.5	16.7	921.	394.	4.872	992.	0.
39.1	179.6	16.9	909.	394.	4.876	992.	0.
40.0	183.8	17.1	897.	394.	4.880	992.	0.
40.9	188.0	17.4	885.	394.	4.885	991.	0.
41.8	192.2	17.6	873.	394.	4.890	991.	0.
42.7	196.4	17.9	860.	394.	4.895	991.	0.
43.6	200.5	18.1	848.	394.	4.900	991.	0.
44.5	204.7	18.4		394.	4.905	991.	0.

VOLUME PUMPED = 208.89 BBL

CELL NO.	DEPTH (FT)	PRESSURE PSIA	LIQ. WT. (LBS)	LIQ. DEN. (LBS/GAL)	GAS WT. (LBS)	AVG. DEN. (LBS/GAL)	DEN. (LBS/GAL)	FLOW RATE (BBL/MIN)
3	1525.	991.	2298.60	13.10	0.00	13.10	13.10	4.70
4	1514.	983.	2298.60	13.10	0.00	13.10	13.10	4.70
5	1502.	975.	2298.60	13.10	0.00	13.10	13.10	4.70
6	1491.	968.	2298.60	13.10	0.00	13.10	13.10	4.70
7	1479.	960.	2298.60	13.10	0.00	13.10	13.10	4.70
8	1468.	952.	2298.60	13.10	0.00	13.10	13.10	4.70
9	1456.	944.	2298.60	13.10	0.00	13.10	13.10	4.70
10	1445.	936.	2298.60	13.10	0.00	13.10	13.10	4.70
11	1433.	929.	2298.60	13.10	0.00	13.10	13.10	4.70
12	1422.	921.	2298.60	13.10	0.00	13.10	13.10	4.70
13	1410.	913.	2298.60	13.10	0.00	13.10	13.10	4.70
14	1399.	905.	2298.60	13.10	0.00	13.10	13.10	4.70
15	1387.	897.	2298.60	13.10	0.00	13.10	13.10	4.70
16	1376.	889.	2298.60	13.10	0.00	13.10	13.10	4.70
17	1364.	882.	2298.60	13.10	0.00	13.10	13.10	4.70
18	1353.	874.	2298.60	13.10	0.00	13.10	13.10	4.70
19	1341.	866.	2298.60	13.10	0.00	13.10	13.10	4.70
20	1330.	858.	2298.60	13.10	0.00	13.10	13.10	4.70
21	1319.	850.	2298.60	13.10	0.00	13.10	13.10	4.70
22	1307.	843.	2298.60	13.10	0.00	13.10	13.10	4.70
23	1296.	835.	2298.60	13.10	0.00	13.10	13.10	4.70
24	1284.	827.	2298.60	13.10	0.00	13.10	13.10	4.70
25	1273.	819.	2298.60	13.10	0.00	13.10	13.10	4.70
26	1261.	811.	2298.60	13.10	0.00	13.10	13.10	4.70
27	1250.	804.	2298.60	13.10	0.00	13.10	13.10	4.70
28	1238.	796.	2298.60	13.10	0.00	13.10	13.10	4.70
29	1227.	788.	2298.60	13.10	0.00	13.10	13.10	4.70
30	1215.	780.	2298.60	13.10	0.00	13.10	13.10	4.70
31	1204.	772.	2298.60	13.10	0.00	13.10	13.10	4.70
32	1192.	764.	2298.60	13.10	0.00	13.10	13.10	4.70
33	1181.	757.	2298.60	13.10	0.00	13.10	13.10	4.70
34	1169.	749.	2298.60	13.10	0.00	13.10	13.10	4.70
35	1158.	741.	2298.60	13.10	0.00	13.10	13.10	4.70
36	1146.	733.	2298.60	13.10	0.00	13.10	13.10	4.70
37	1135.	725.	2298.60	13.10	0.00	13.10	13.10	4.70
38	1124.	718.	2298.60	13.10	0.00	13.10	13.10	4.70
39	1112.	710.	2298.60	13.10	0.00	13.10	13.10	4.70
40	1101.	702.	2298.60	13.10	0.00	13.10	13.10	4.70
41	1089.	694.	2298.60	13.10	0.00	13.10	13.10	4.70
42	1078.	686.	2298.60	13.10	0.00	13.10	13.10	4.70
43	1066.	678.	2298.60	13.10	0.00	13.10	13.10	4.70
44	1055.	671.	2298.60	13.10	0.00	13.10	13.10	4.70
45	1043.	663.	2298.60	13.10	0.00	13.10	13.10	4.70
46	1032.	655.	2298.60	13.10	0.00	13.10	13.10	4.70
47	1020.	647.	2298.60	13.10	0.00	13.10	13.10	4.70
48	1009.	639.	2298.60	13.10	0.00	13.10	13.10	4.70
49	997.	632.	2298.60	13.10	0.00	13.10	13.10	4.70
50	986.	624.	2298.60	13.10	0.00	13.10	13.10	4.70
51	974.	616.	2193.32	12.50	0.00	12.50	12.50	4.70
52	963.	609.	2193.32	12.50	0.00	12.50	12.50	4.70
53	952.	604.	1535.32	12.50	26.12	7.22	7.22	4.75
54	937.	598.	1535.32	12.50	25.96	7.21	7.21	4.77
55	923.	593.	1535.32	12.50	25.80	7.20	7.20	4.80
56	909.	588.	1535.32	12.50	25.64	7.19	7.19	4.82
57	895.	582.	1535.32	12.50	25.48	7.17	7.17	4.82

58	881.	577.	1535.	32	50	12.	50	2	32	7	16	4.	85
59	866.	572.	1535.	16	50	12.	50	2	16	7.	15	4.	87
60	852.	566.	1535.	00	50	12.	50	5	00	7.	14	4.	90
61	838.	560.	1997.	40	50	12.	50	7	40	10.	63	4.	91
62	826.	552.	1993.	00	50	12.	50	0	00	12.	50	4.	91
63	814.	545.	2193.	00	50	12.	50	0	00	12.	50	4.	91
64	803.	537.	2193.	00	50	12.	50	0	00	12.	50	4.	91
65	791.	530.	2193.	00	50	12.	50	0	00	12.	50	4.	91
66	780.	522.	2193.	00	50	12.	50	0	00	12.	50	4.	91
67	768.	515.	2193.	00	50	12.	50	0	00	12.	50	4.	91
68	757.	507.	2193.	00	50	12.	50	0	00	12.	50	4.	91
69	745.	500.	2193.	00	50	12.	50	0	00	12.	50	4.	91
70	734.	492.	2193.	00	50	12.	50	0	00	12.	50	4.	91
71	722.	485.	2193.	00	50	12.	50	0	00	12.	50	4.	91
72	711.	478.	2193.	00	50	12.	50	0	00	12.	50	4.	91
73	699.	470.	2193.	00	50	12.	50	0	00	12.	50	4.	91
74	688.	463.	2193.	00	50	12.	50	0	00	12.	50	4.	91
75	676.	455.	2193.	00	50	12.	50	0	00	12.	50	4.	91
76	665.	448.	2193.	00	50	12.	50	0	00	12.	50	4.	91
77	653.	440.	2193.	00	50	12.	50	0	00	12.	50	4.	91
78	642.	433.	2193.	00	50	12.	50	0	00	12.	50	4.	91
79	631.	425.	2193.	00	50	12.	50	0	00	12.	50	4.	91
80	619.	418.	2193.	00	50	12.	50	0	00	12.	50	4.	91
81	608.	410.	2193.	00	50	12.	50	0	00	12.	50	4.	91
82	596.	403.	2193.	00	50	12.	50	0	00	12.	50	4.	91
83	585.	396.	2193.	00	50	12.	50	0	00	12.	50	4.	91
84	573.	388.	2193.	00	50	12.	50	0	00	12.	50	4.	91
85	562.	381.	2193.	00	50	12.	50	0	00	12.	50	4.	91
86	550.	373.	2193.	00	50	12.	50	0	00	12.	50	4.	91
87	539.	366.	2193.	00	50	12.	50	0	00	12.	50	4.	91
88	527.	358.	2193.	00	50	12.	50	0	00	12.	50	4.	91
89	516.	351.	2193.	00	50	12.	50	0	00	12.	50	4.	91
90	504.	343.	2193.	00	50	12.	50	0	00	12.	50	4.	91
91	493.	336.	2193.	00	50	12.	50	0	00	12.	50	4.	91
92	481.	328.	2193.	00	50	12.	50	0	00	12.	50	4.	91
93	470.	321.	2193.	00	50	12.	50	0	00	12.	50	4.	91
94	458.	314.	2193.	00	50	12.	50	0	00	12.	50	4.	91
95	447.	306.	2193.	00	50	12.	50	0	00	12.	50	4.	91
96	436.	299.	2193.	00	50	12.	50	0	00	12.	50	4.	91
97	424.	291.	2193.	00	50	12.	50	0	00	12.	50	4.	91
98	413.	284.	2193.	00	50	12.	50	0	00	12.	50	4.	91
99	401.	276.	2193.	00	50	12.	50	0	00	12.	50	4.	91
100	390.	269.	2193.	00	50	12.	50	0	00	12.	50	4.	91
101	378.	261.	2193.	00	50	12.	50	0	00	12.	50	4.	91
102	367.	254.	2193.	00	50	12.	50	0	00	12.	50	4.	91
103	355.	246.	2193.	00	50	12.	50	0	00	12.	50	4.	91
104	344.	239.	2193.	00	50	12.	50	0	00	12.	50	4.	91
105	332.	232.	2193.	00	50	12.	50	0	00	12.	50	4.	91
106	321.	224.	2193.	00	50	12.	50	0	00	12.	50	4.	91
107	309.	217.	2193.	00	50	12.	50	0	00	12.	50	4.	91
108	298.	209.	2193.	00	50	12.	50	0	00	12.	50	4.	91
109	286.	202.	2193.	00	50	12.	50	0	00	12.	50	4.	91
110	275.	194.	2193.	00	50	12.	50	0	00	12.	50	4.	91
111	264.	187.	2193.	00	50	12.	50	0	00	12.	50	4.	91
112	252.	179.	2193.	00	50	12.	50	0	00	12.	50	4.	91
113	241.	172.	2193.	00	50	12.	50	0	00	12.	50	4.	91
114	229.	164.	2193.	00	50	12.	50	0	00	12.	50	4.	91
115	219.	157.	2193.	00	50	12.	50	0	00	12.	50	4.	91
116	206.	150.	2193.	00	50	12.	50	0	00	12.	50	4.	91
117	195.	142.	2193.	00	50	12.	50	0	00	12.	50	4.	91
118	183.	135.	2193.	00	50	12.	50	0	00	12.	50	4.	91

119	172.	127.	2193.32	12.50	0.0	12.50	4.91
120	160.	120.	2193.32	12.50	0.0	12.50	4.91
121	149.	112.	2193.32	12.50	0.0	12.50	4.91
122	137.	105.	2193.32	12.50	0.0	12.50	4.91
123	126.	97.	2193.32	12.50	0.0	12.50	4.91
124	114.	90.	2193.32	12.50	0.0	12.50	4.91
125	103.	82.	2193.32	12.50	0.0	12.50	4.91
126	91.	75.	2193.32	12.50	0.0	12.50	4.91
127	80.	67.	2193.32	12.50	0.0	12.50	4.91
128	69.	60.	2193.32	12.50	0.0	12.50	4.91
129	57.	53.	2193.32	12.50	0.0	12.50	4.91
130	46.	45.	2193.32	12.50	0.0	12.50	4.91
131	34.	38.	2193.32	12.50	0.0	12.50	4.91
132	23.	30.	2193.32	12.50	0.0	12.50	4.91
133	11.	23.	2138.27	12.50	0.0	12.50	4.91
134	0.	15.	0.0	0.0	0.0	0.0	4.91

ME MIN	VOLUME BBL	GAIN BBL	GAS TOP FT	DP PRES PSIA	JD OUT 8BL/MIN	AN PRES PSIA	GAS FLOW SCF/D
44.4	208.9	18.7	836.	394.	4.911	991.	0.
45.3	213.1	19.0	824.	393.	4.916	991.	0.
46.2	217.4	19.3	811.	393.	4.923	991.	0.
47.1	221.6	19.6	799.	393.	4.929	990.	0.
48.0	225.5	19.9	787.	393.	4.936	990.	0.
48.9	229.8	20.2	774.	393.	4.943	990.	0.
49.8	234.0	20.5	762.	392.	4.950	990.	0.
50.7	238.1	20.9	750.	392.	4.958	990.	0.
51.6	242.3	21.2	737.	392.	4.966	989.	0.
52.4	246.5	21.6	725.	392.	4.974	989.	0.
53.3	250.7	22.0	712.	391.	4.983	989.	0.
54.2	254.8	22.4	700.	391.	4.992	988.	0.
55.1	259.0	22.8	687.	391.	5.002	988.	0.
56.0	263.2	23.2	675.	390.	5.013	988.	0.
56.9	267.4	23.6	662.	390.	5.024	987.	0.
57.8	271.6	24.1	649.	389.	5.035	987.	0.
58.7	275.7	24.6	636.	389.	5.047	986.	0.
59.6	279.9	25.0	624.	388.	5.060	986.	0.
60.5	284.1	25.6	611.	388.	5.074	985.	0.
61.3	288.3	26.1	598.	387.	5.089	985.	0.
62.2	292.4	26.7	585.	387.	5.105	984.	0.
63.1	296.6	27.2	572.	386.	5.121	983.	0.
64.0	300.8	27.9	558.	386.	5.139	982.	0.
64.9	305.0	28.5	545.	384.	5.159	982.	0.
65.8	309.2	29.2	532.	383.	5.179	981.	0.
66.7	313.3	29.9	518.	382.	5.201	980.	0.
67.6	317.5	30.6	505.	381.	5.225	979.	0.
68.4	321.7	31.4	491.	380.	5.251	978.	0.
69.3	325.9	32.3	477.	379.	5.279	977.	0.
70.2	330.0	33.2	464.	378.	5.310	975.	0.
71.1	334.2	34.1	449.	377.	5.344	974.	0.
72.0	338.4	35.2	435.	375.	5.380	973.	0.
72.9	342.6	36.2	421.	375.	5.421	971.	0.
73.8	346.8	37.4	406.	372.	5.466	969.	0.
74.7	350.9	38.7	391.	370.	5.516	967.	0.
75.6	355.1	40.1	376.	368.	5.572	965.	0.
76.4	359.3	41.6	360.	366.	5.637	963.	0.
77.3	363.5	43.3	344.	363.	5.711	960.	0.
78.2	367.6	45.1	328.	360.	5.796	957.	0.
79.1	371.8	47.2	310.	357.	5.896	954.	0.
80.0	376.0	49.6	292.	353.	6.013	950.	0.
80.9	380.2	52.3	273.	348.	6.154	946.	0.
81.8	384.4	55.5	253.	343.	6.329	940.	0.
82.7	388.5	59.4	231.	336.	6.554	934.	0.
83.6	392.7	64.3	206.	328.	6.858	925.	0.
84.4	396.9	70.9	177.	316.	7.299	914.	0.
85.3	401.1	80.5	139.	300.	8.019	897.	0.
86.2	405.2	97.4	81.	270.	9.496	867.	0.
87.1	409.4	124.3	0.	222.	12.310	820.	0.
88.0	413.6	131.1	0.	210.	17.335	807.	0.

VOLUME PUMPED = 417.77 BBL

CELL NO.	DEPTH (FT)	PRESSURE PSIA	LIQ. WT. (LBS)	LIQ. DEN. (LBS/GAL)	GAS WT. (LBS)	AVG. DEN. (LBS/GAL)	FLOW RATE BBL/MIN
3	1525.	807.	2298.60	13.10	0.00	13.10	4.70
4	1514.	800.	2298.60	13.10	0.00	13.10	4.70
5	1502.	792.	2298.60	13.10	0.00	13.10	4.70
6	1491.	784.	2298.60	13.10	0.00	13.10	4.70
7	1479.	776.	2298.60	13.10	0.00	13.10	4.70
8	1468.	768.	2298.60	13.10	0.00	13.10	4.70
9	1456.	761.	2298.60	13.10	0.00	13.10	4.70
10	1445.	753.	2298.60	13.10	0.00	13.10	4.70
11	1433.	745.	2298.60	13.10	0.00	13.10	4.70
12	1422.	737.	2298.60	13.10	0.00	13.10	4.70
13	1410.	729.	2298.60	13.10	0.00	13.10	4.70
14	1399.	721.	2298.60	13.10	0.00	13.10	4.70
15	1387.	714.	2298.60	13.10	0.00	13.10	4.70
16	1376.	706.	2298.60	13.10	0.00	13.10	4.70
17	1364.	698.	2298.60	13.10	0.00	13.10	4.70
18	1353.	690.	2298.60	13.10	0.00	13.10	4.70
19	1341.	682.	2298.60	13.10	0.00	13.10	4.70
20	1330.	675.	2298.60	13.10	0.00	13.10	4.70
21	1319.	667.	2298.60	13.10	0.00	13.10	4.70
22	1307.	659.	2298.60	13.10	0.00	13.10	4.70
23	1296.	651.	2298.60	13.10	0.00	13.10	4.70
24	1284.	643.	2298.60	13.10	0.00	13.10	4.70
25	1273.	636.	2298.60	13.10	0.00	13.10	4.70
26	1261.	628.	2298.60	13.10	0.00	13.10	4.70
27	1250.	620.	2298.60	13.10	0.00	13.10	4.70
28	1238.	612.	2298.60	13.10	0.00	13.10	4.70
29	1227.	604.	2298.60	13.10	0.00	13.10	4.70
30	1215.	596.	2298.60	13.10	0.00	13.10	4.70
31	1204.	589.	2298.60	13.10	0.00	13.10	4.70
32	1192.	581.	2298.60	13.10	0.00	13.10	4.70
33	1181.	573.	2298.60	13.10	0.00	13.10	4.70
34	1169.	565.	2298.60	13.10	0.00	13.10	4.70
35	1158.	557.	2298.60	13.10	0.00	13.10	4.70
36	1146.	550.	2298.60	13.10	0.00	13.10	4.70
37	1135.	542.	2298.60	13.10	0.00	13.10	4.70
38	1124.	534.	2298.60	13.10	0.00	13.10	4.70
39	1112.	526.	2298.60	13.10	0.00	13.10	4.70
40	1101.	518.	2298.60	13.10	0.00	13.10	4.70
41	1089.	510.	2298.60	13.10	0.00	13.10	4.70
42	1078.	503.	2298.60	13.10	0.00	13.10	4.70
43	1066.	495.	2298.60	13.10	0.00	13.10	4.70
44	1055.	487.	2298.60	13.10	0.00	13.10	4.70
45	1043.	479.	2298.60	13.10	0.00	13.10	4.70
46	1032.	471.	2298.60	13.10	0.00	13.10	4.70
47	1020.	464.	2298.60	13.10	0.00	13.10	4.70
48	1009.	456.	2298.60	13.10	0.00	13.10	4.70
49	997.	448.	2298.60	13.10	0.00	13.10	4.70
50	986.	440.	2298.60	13.10	0.00	13.10	4.70
51	974.	432.	2298.60	13.10	0.00	13.10	4.70
52	963.	425.	2298.60	13.10	0.00	13.10	4.70
53	952.	417.	2298.60	13.10	0.00	13.10	4.70
54	940.	409.	2298.60	13.10	0.00	13.10	4.70
55	929.	401.	2298.60	13.10	0.00	13.10	4.70
56	917.	393.	2298.60	13.10	0.00	13.10	4.70
57	906.	385.	2298.60	13.10	0.00	13.10	4.70

894.	378.	2298.60	13.10	00	13.10	0	4.70
883.	370.	2298.60	13.10	00	13.10	0	4.70
871.	362.	2298.60	13.10	00	13.10	0	4.70
860.	354.	2298.60	13.10	00	13.10	0	4.70
848.	346.	2298.60	13.10	00	13.10	0	4.70
837.	339.	2298.60	13.10	00	13.10	0	4.70
825.	331.	2298.60	13.10	00	13.10	0	4.70
814.	323.	2298.60	13.10	00	13.10	0	4.70
802.	315.	2298.60	13.10	00	13.10	0	4.70
791.	307.	2298.60	13.10	00	13.10	0	4.70
779.	299.	2298.60	13.10	00	13.10	0	4.70
768.	292.	2298.60	13.10	00	13.10	0	4.70
757.	284.	2298.60	13.10	00	13.10	0	4.70
745.	276.	2298.60	13.10	00	13.10	0	4.70
734.	268.	2298.60	13.10	00	13.10	0	4.70
722.	260.	2298.60	13.10	00	13.10	0	4.70
711.	253.	2298.60	13.10	00	13.10	0	4.70
699.	245.	2298.60	13.10	00	13.10	0	4.70
688.	237.	2298.60	13.10	00	13.10	0	4.70
676.	229.	2298.60	13.10	00	13.10	0	4.70
665.	221.	2298.60	13.10	00	13.10	0	4.70
653.	214.	2298.60	13.10	00	13.10	0	4.70
642.	206.	2298.60	13.10	00	13.10	0	4.70
630.	198.	2298.60	13.10	00	13.10	0	4.70
619.	190.	2298.60	13.10	00	13.10	0	4.70
607.	182.	2298.60	13.10	00	13.10	0	4.70
596.	174.	2298.60	13.10	00	13.10	0	4.70
584.	167.	2298.60	13.10	00	13.10	0	4.70
573.	159.	2298.60	13.10	00	13.10	0	4.70
562.	151.	2298.60	13.10	00	13.10	0	4.70
550.	143.	2298.60	13.10	00	13.10	0	4.70
539.	135.	2298.60	13.10	00	13.10	0	4.70
527.	128.	2298.60	13.10	00	13.10	0	4.70
516.	120.	2298.60	13.10	00	13.10	0	4.70
504.	112.	2298.60	13.10	00	13.10	0	4.70
493.	104.	2298.60	13.10	00	13.10	0	4.70
481.	96.	2298.60	13.10	00	13.10	0	4.70
470.	88.	2298.60	13.10	00	13.10	0	4.70
458.	81.	2298.60	13.10	00	13.10	0	4.70
447.	73.	2298.60	13.10	00	13.10	0	4.70
435.	65.	2298.60	13.10	00	13.10	0	4.70
424.	57.	2298.60	13.10	00	13.10	0	4.70
412.	49.	2298.60	13.10	00	13.10	0	4.70
401.	42.	2193.32	12.50	00	12.50	0	4.70
389.	35.	2193.32	12.50	26.12	0.69	13.54	13.54
378.	29.	1535.32	12.50	25.96	0.57	26.23	26.23
360.	24.	1535.32	12.50	6.05	0.45	26.23	26.23
353.	19.	360.26	12.50	0.00	0.45	10.81	10.81
340.	15.	0.00	10.00	0.00	0.00	0.00	0.00

TIME	VOLUME	GAIN	GAS TOP	DP PRES	UD OUT	AN PRES	GAS FLOW
↓	BBL	BBL	FT	PSIA	3L/MIN	PSIA	SCF/D
88.9	417.8	131.2	0.	210.	26.227	808.	0.
89.8	422.0	128.7	0.	215.	20.067	812.	0.
90.7	426.1	125.1	0.	222.	24.948	819.	0.
91.6	430.3	121.2	0.	229.	27.239	826.	0.
92.4	434.5	117.2	0.	236.	28.386	834.	0.
93.3	438.7	113.2	0.	244.	29.266	841.	0.
94.2	442.8	109.2	0.	251.	30.111	849.	0.
95.1	447.0	105.2	0.	259.	30.986	856.	0.
96.0	451.2	101.2	0.	266.	31.915	864.	0.

APPENDIX C

MMS Survey of Field Practice

C
II
SI

I
E
D
UH
OF
/
d
C1
AA
/

lle

Operator: AMOCO PRODUCTION CO.

OCS Lease: G 5844

Well No.: 1

Area/Block: Miss. Canyon 400

Water Depth: 1015 ft.

ID of Kill line: 3 in.

ID of Choke line: 3 in.

OD of Riser: 20 in.

ID of Riser: 19-3/4 in.

Collapse Pressure of Riser: unk psi
Rated for 2000' before collapse w/20% safety factor
In Terms of Water Depth: unk psi

Size of BOP Stack: 18-3/4 in.

WP of Stack: 10000 (5000 anu) psi

Size of Diverter lines: 10 in.

Rig has Gumbo Box? 0 Yes
X No

Additives used to break up gumbo
Rating and Type PO on top of
Riser: Regan

PO tested to 400 psi

Rig Name: ALASKAN STAR

Drilling Supt.: Jimmy Reed

Supt. Tel. No.: (504) 586-6007

Procedure for Circulating Gas Out of Stack
After a Kick:

Kill well, keeping annular closed (2000psi
max); fill riser w/kill wt; displace choke
line w/SW; V-tube bubble; divert.

Is Procedure In Drilling Manual? X Yes
0 No

- 1) Extend choke and kill lines-show outlets on location
- 2) Label rams - pipe, variable, blind/shear

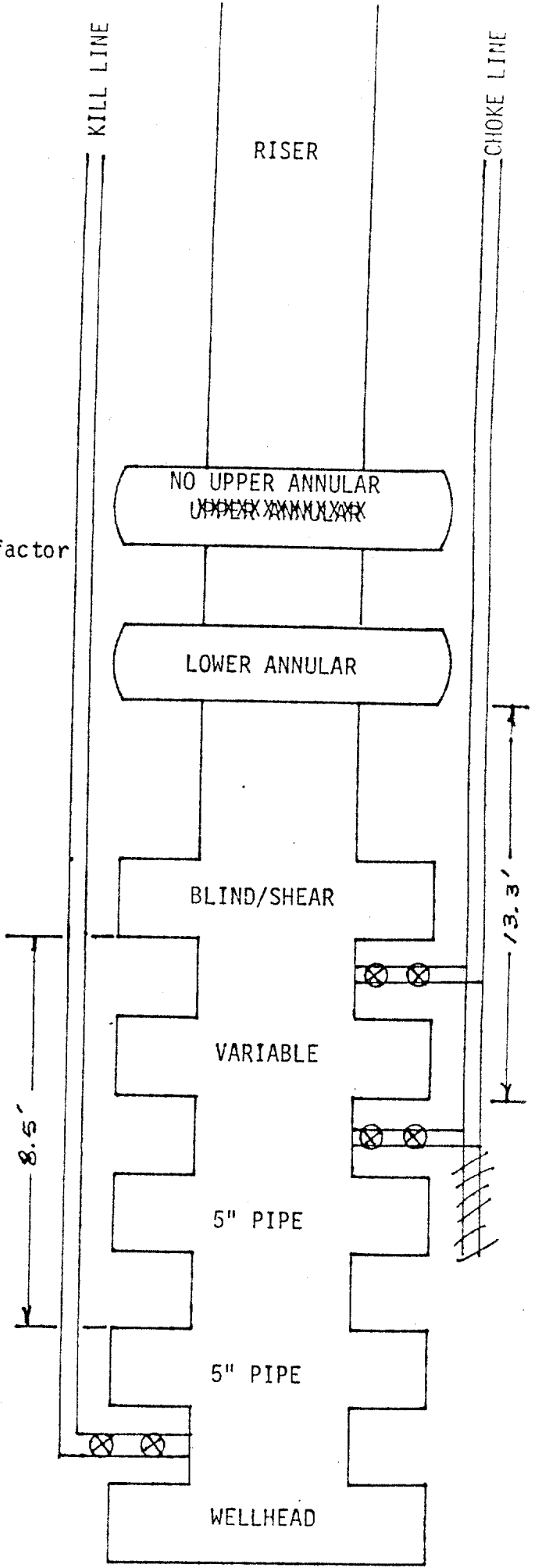

OPERATOR Amoco

LEASE OCS-G 5812

WELL 1 WD 575

AREA/BLOCK EW 952

ID KILL LINE 3"

ID CHOKE LINE 3"

OD RISER 21"

ID RISER 20"

COLLAPSE PRESSURE OF RISER 1550*

IN TERMS OF WATER DEPTH 3500'

SIZE OF BOP STACK 18 3/4

WORKING PRESSURE OF STACK 10 m

SIZE OF DIVERTER LINES 10"

DOES RIG HAVE GUMBO BOX No

RATING & TYPE PACK OFF ON
TOP OF RISER 1200* Reagan KFDH

DOES IT REMAIN IN PLACE DURING
DRILLING OPERATIONS Yes

RIG NAME Glomar Coastal Sea

DRILLING SUPT. TROY MASON

SUPT. TELE. NO. (318) 984-1000

IS THE FOLLOWING PROCEDURE IN
THE DRILLING MANUAL No

PROCEDURE FOR CIRCULATING GAS
OUT OF STACK AFTER KICK:
1. All shut in on pipe rams & pipe hung off.
2. Choke fully & observe well.
3. Close diverter & take returns to pit.
4. Displace upper kill line & riser with kill mud.
5. Shut annular & open rams.
6. Pump down choke & up kill line to displace any
gas & clear this volume.
7. Close diverter & annular.
8. Circulate kill mud.

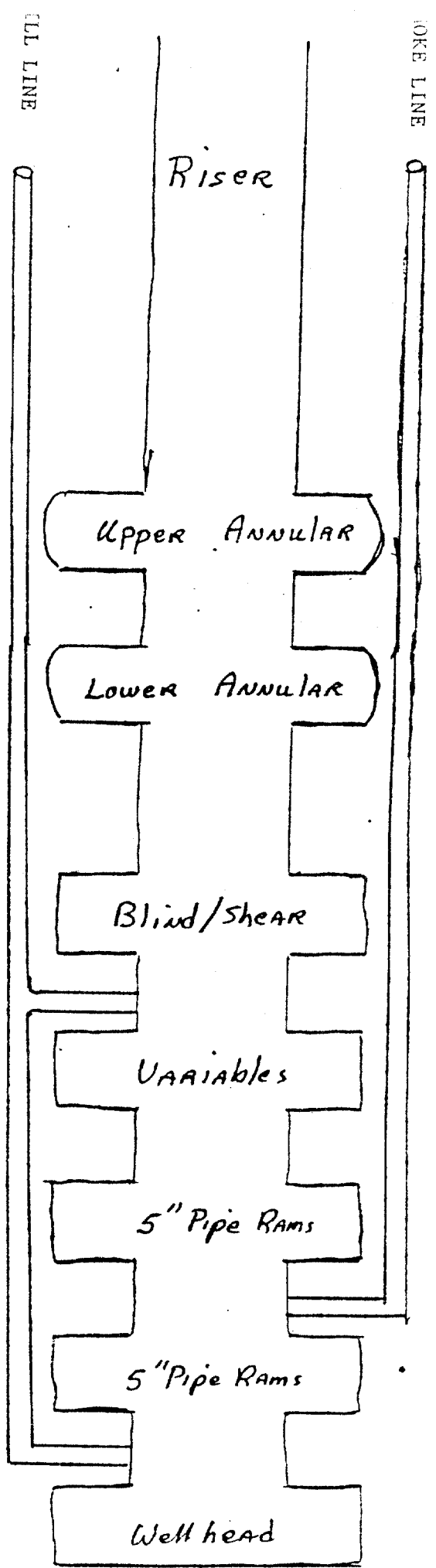

OPERATOR _____

LEASE OCS-G 5913

WELL 1 WD 1680

A/BLOCK GC-235

ID KILL LINE 3"

ID CHOKE LINE 3"

OD RISER 20"

ID RISER 19"

COLLAPSE PRESSURE OF RISER 800

IN TERMS OF WATER DEPTH 1788

SIZE OF BOP STACK 18 3/4

WORKING PRESSURE OF STACK 10 m

SIZE OF DIVERTER LINES 8"

DOES RIG HAVE GUMBO BOX No

RATING & TYPE PACK OFF ON

TOP OF RISER 500# Reagan KFDS

DOES IT REMAIN IN PLACE DURING

DRILLING OPERATIONS Yes

RIG NAME Penrod 75

DRILLING SUPT. Ken Burgess

SUPT. TELE. NO. (504) 363-4490

IS THE FOLLOWING PROCEDURE IN

THE DRILLING MANUAL No

PROCEDURE FOR CIRCULATING GAS

OUT OF STACK AFTER KICK:

lose lower pipe rams.

ump seawater down kill & out choke line

After kill & choke lines are displaced, open

ANNULAR & allow mud in riser u-tube

out of kill & choke lines.

circulate riser & stack with kill wt. mud.

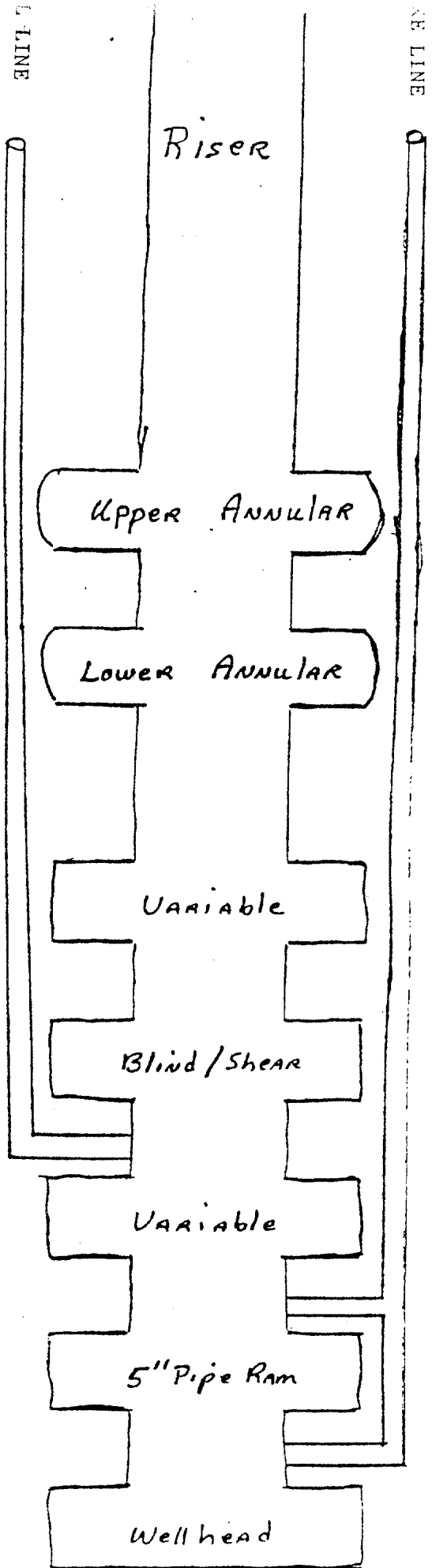

Well head

OPERATOR: DIAMOND SHAMROCK
 LEASE : G-6365
 AREA & BLK. G8.224
 ID KILL LINE: 3"
 ID CHOKE LINE: 3"
 OD RISER : 20 1/2" X 1/2" w.t.
 ID RISER : 19 13/16

WD 790

COLLAPSE PRESSURE OF RISER: 1609' wd.
 (in terms of water depth) (716 PSI) Full Coll.

SIZE OF BOP STACK: 18 3/4 - 10 m
 SIZE OF DIVERTOR LINES: 12"

DOES RIG HAVE GUMBO BOX ? NO

RATING AND TYPED P ON TOP
 OF RISER : REAGAN 3 m

RIG NAME: ZAPATA NEPTUNE

DRILLING SUPT: DAN BECKER
 SUPT. TELE. NO. 713-452-2229

Procedure for circulating gas out of stack after kick;

SEE : NEXT PAGE -

Is procedure in drilling manual, NO, NOT YET

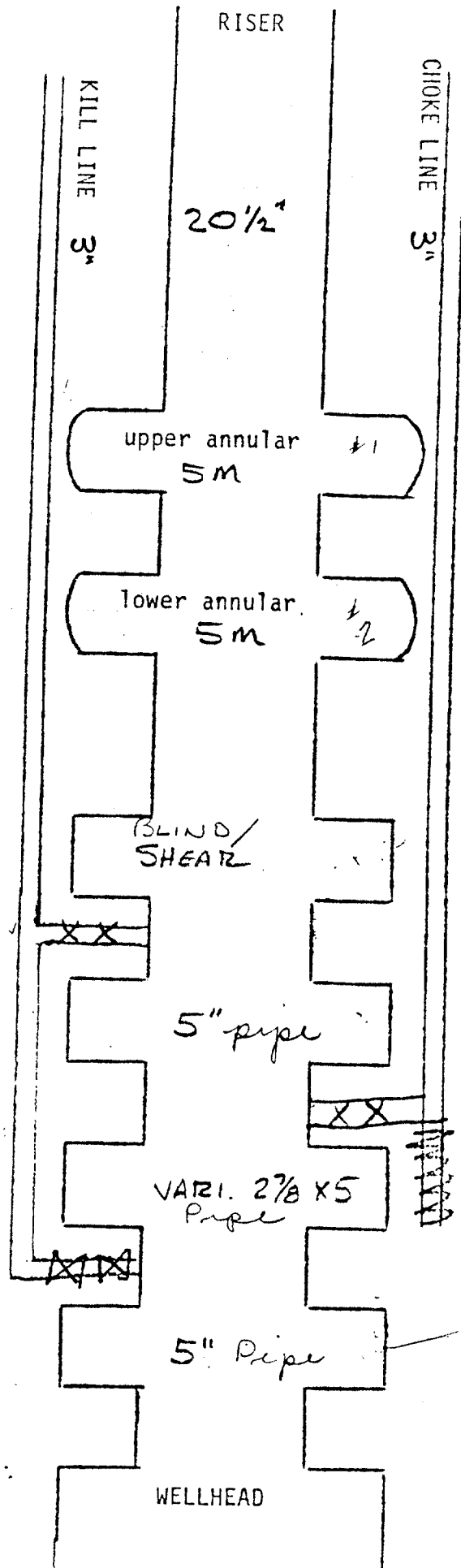

WELLHEAD

KICK PROCEDURES, PRESENT STOCK CONFIGURATIONS
OCTOBER 8, 1984

1. Divertor packer will always be installed when drill pipe is in the hole as a matter procedure.
2. All BOP C/K type valves kept closed.
3. Upper sub-sea C/K valve lined up to choke manifold.
4. Kick is indicated.
Close #2 annular, close diverter, line up over board lines, make sure flow line to shale shaker is closed. Open upper sub-sea C/K line, outer valve first.
5. Close and hang off on #2 ram.
6. While weighting up mud. Observe choke line to see if there is gas between #2 ram and #2 annular. If there is, then gas will migrate up and you will have flow at the choke manifold.
7. Close upper C/K subsea valves.
8. Kill well thru middle C/K valves.
9. After well is static circulate kill-weight mud down the lower most C/K line with returns up middle C/K lines, sweeping BOP. This will sweep BOP and also insure kill-weight mud in both choke and kill lines.
10. Check for pressure. Make sure well is static thru both choke and kill lines.
11. Open uppermost set of C/K outlets, wait 30 minutes, check for flow. This will indicate if the #2 ram leaked during the killing of the well.
12. Open lower C/K valves, close #3 rams. Have choke manifold lined up so you can read pressure under #3 ram while circulating out riser.
13. Open #2 annular, wait 30 minutes with diverter still lined up on overboard lines.
14. Do not circulate riser while you are waiting this 30 minutes.
15. Open diverter route to flow-back across shale shaker.
16. Start circulating out riser thru upper C/K valves. After circulating 1/4 the volume of the riser, stop pumps. observe riser for 5 minutes.
17. If flow observed, close diverter and line up overboard lines.

18. If no flow after waiting five minutes go to next step.
19. Resume circulating. Circulate another 1/4 volume of riser. Stop pumps - wait 5 minutes. If flow, close diverter and line up overboard lines.
20. If no flow after 5 minutes. resume and finish circulation.
21. Close upper C/K line, open middle C/K line, check for pressure. If no pressure, open #2 ram and circulate out 1/2 volume of riser. Check for flow; if flowing, line up overboard lines.
22. If no flow after 5 minutes, resume circulating.
23. Check pressure on C/K lines to see if well is still static. If well is static, open #3 rams.
24. Continue operations.

Operator: EXXON CORPORATION

OCS Lease: G 6943

Well No.: 1

Area/Block: Miss. Canyon 239

Water Depth: 1734 ft.

ID of Kill line: 3 in.

ID of Choke line: 3 in.

OD of Riser: 18-5/8 in.

ID of Riser: 17-3/8 in.

Collapse Pressure of Riser: unk psi
 Rated for 4000'; SF=3; MW=16lb
 In Terms of Water Depth: unk psi

Size of BOP Stack: 16-3/4 in.

WP of Stack: 10000 (5000 anu) psi

Size of Diverter lines: 12 in.
 w/750 series flanges

Rig has Gumbo Box? Yes
 No

Rating and Type PO on top of
 Riser: Regan KFD

Diverter tested to 100 psi.

Rig Name: SEDCO 472

Drilling Supt.: Howard Shauberger

Supt. Tel. No.: (504) 561-4732 (N.O.)
(504) 561-3230

Procedure for Circulating Gas Out of Stack
 After a Kick:

Shut upper/lower annular; circ mud thru
kill & choke & thru m/g sep first, divert
ovbd next.

Is Procedure In Drilling Manual? Yes
 No

- 1) Extend choke and kill lines-show outlets on location
- 2) Label rams - pipe, variable, blind/shear

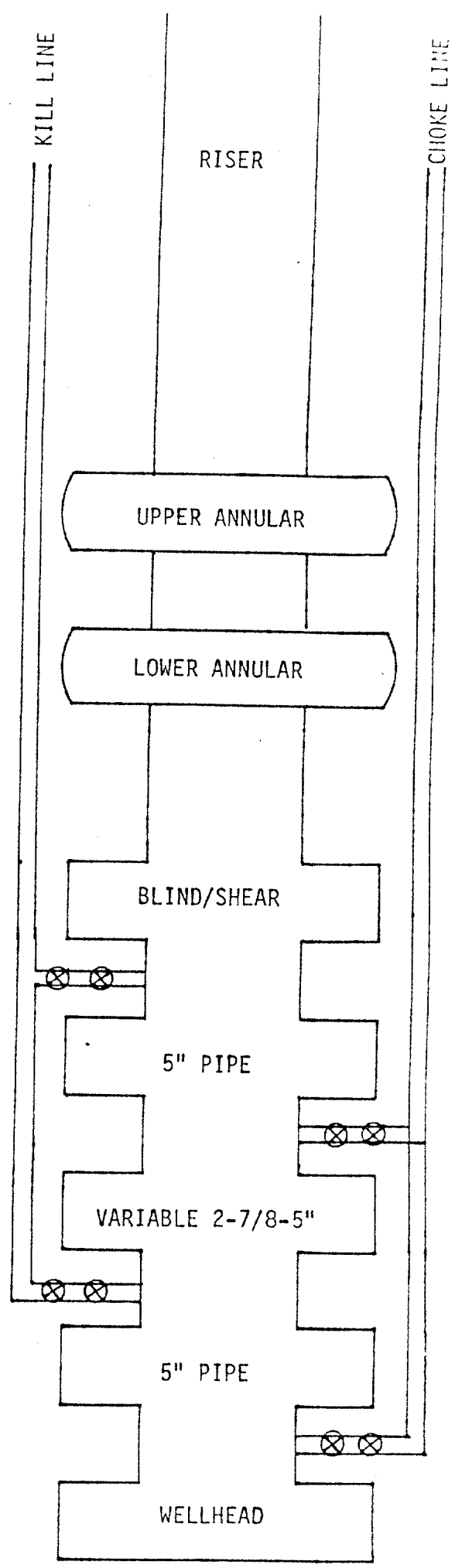

OPERATOR Exxon

LEASE OC5-G 4931

WELL 1 WD 1375

AREA/BLOCK EW-438

ID KILL LINE 2.3"

ID CHOKE LINE 2.3"

OD RISER 18 3/4"

ID RISER 17 1/2"

COLLAPSE PRESSURE OF RISER 894*

IN TERMS OF WATER DEPTH 2000'

SIZE OF BOP STACK 16 3/4

WORKING PRESSURE OF STACK 10 M

SIZE OF DIVERTER LINES 10"

DOES RIG HAVE GUMBO BOX no

RATING & TYPE PACK OFF ON
TOP OF RISER 1500* Reagan KFDH

DOES IT REMAIN IN PLACE DURING
DRILLING OPERATIONS Yes

RIG NAME Glomar Pacific

DRILLING SUPT. Bob McGlomey

SUPT. TELE. NO. (504) 561-4260

IS THE FOLLOWING PROCEDURE IN
THE DRILLING MANUAL Yes

PROCEDURE FOR CIRCULATING GAS
OUT OF STACK AFTER KICK:

use bottom pipe rams. Open kill line (upper) To
swaco choke and allow trap pressure
release to surface. Fill choke & kill line
with seawater. Close pack off & open diverter
lines. Open ANNULAR & allow mud & gas to
bubble up choke & kill line. Circulate kill
weight mud in riser.

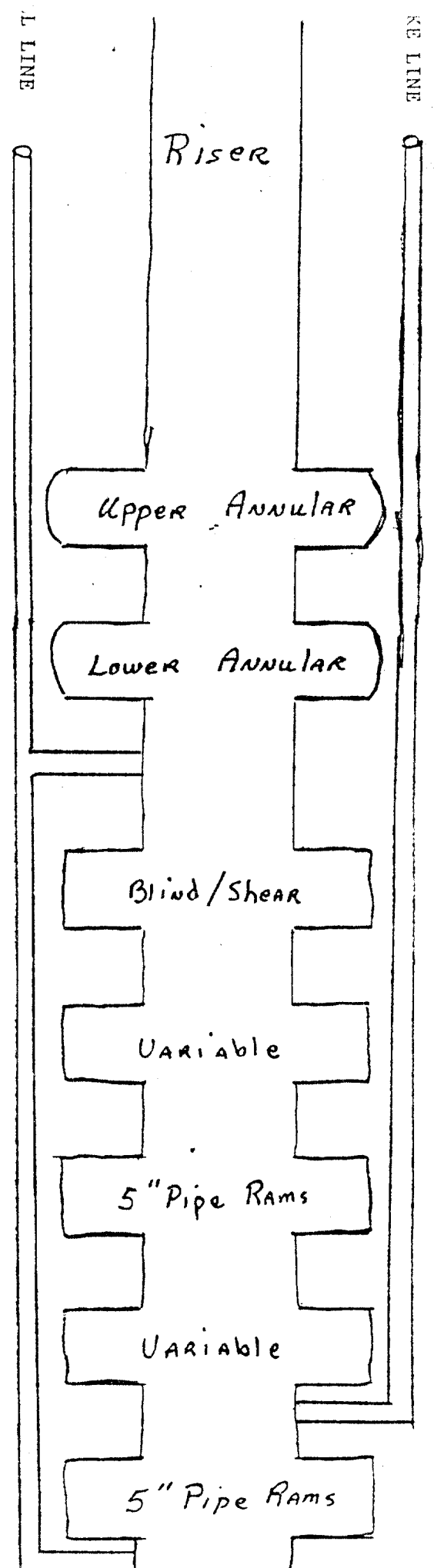

Operator: MARATHON OIL CO.

OCS Lease: G 5842

Well No.: 1

Area/Block: Miss. Canyon 366

Water Depth: 757 ft.

ID of Kill line: 3-1/16 in.

ID of Choke line: 3-1/16 in.

OD of Riser: 21-1/4 in.

ID of Riser: 20 in.

Collapse Pressure of Riser: (13.15psi/ft)psi
 Rated for 2900'.

In Terms of Water Depth: 1286 psi

Size of BOP Stack: 18-3/4 in.

WP of Stack: 10000 (5000 anu) psi

Size of Diverter lines: 10 in.

Air operated; diverts fore and aft

Rig has Gumbo Box? Yes
 No

Rating and Type PO on top of
 Riser: Regan KFDH

Rated @ 500 psi

Rig Name: GLOMAR ATLANTIC

Drilling Supt.: Ray Badon

Supt. Tel. No.: (318) 233-8240 8-4 p.m.
(504) 534-7446 X208 after 4pm

Procedure for Circulating Gas Out of Stack
 After a Kick:

Close upper annular (under 2500 psi); pump
bubble between upper 5" and annulars; kill
well; close lower annular and lower pipe rams;
pump thru m/g sep. (preferred) or thru diverter.

Is Procedure In Drilling Manual? Yes
 Method being prepared for man. No

- 1) Extend choke and kill lines-show outlets on location
- 2) Label rams - pipe, variable, blind/shear

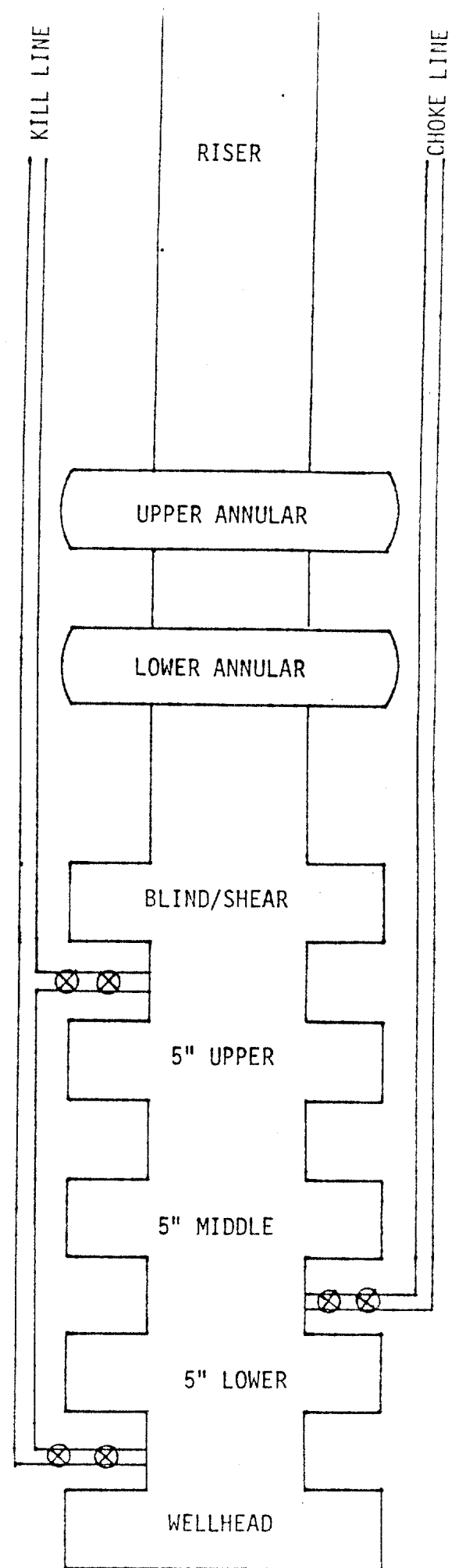

Circulating out bubble above the annular:

1. Close the diverter
2. Close the upper 5"
3. Open the upper annular
4. Displace the riser

Must pump bubble out of the riser first thru the diverter; bubble size should then be reduced.

LEASE OCS-G 5901

WELL 1 WD 1295'

AREA/BLOCK GC-110

ID KILL LINE 3"

ID CHOKE LINE 3"

OD RISER 21"

ID RISER 19 3/4"

COLLAPSE PRESSURE OF RISER 1300*

IN TERMS OF WATER DEPTH 2900'

SIZE OF BOP STACK 18 3/4

WORKING PRESSURE OF STACK 10 m

SIZE OF DIVERTER LINES 16"

DOES RIG HAVE GUMBO BOX No

RATING & TYPE PACK OFF ON
TOP OF RISER 200* Yes Reagan KFDS

DOES IT REMAIN IN PLACE DURING
DRILLING OPERATIONS Yes

RIG NAME Sedco 702

DRILLING SUPT. Jerry Lee

SUPT. TELE. NO. (318) 233-8240

IS THE FOLLOWING PROCEDURE IN
THE DRILLING MANUAL _____

PROCEDURE FOR CIRCULATING GAS
OUT OF STACK AFTER KICK:

Put well on RAMS + hang off as to not
Trap gas in stack + riser.
Circulate lowest kill line and highest
choke line.
Circulate kill mud through riser.

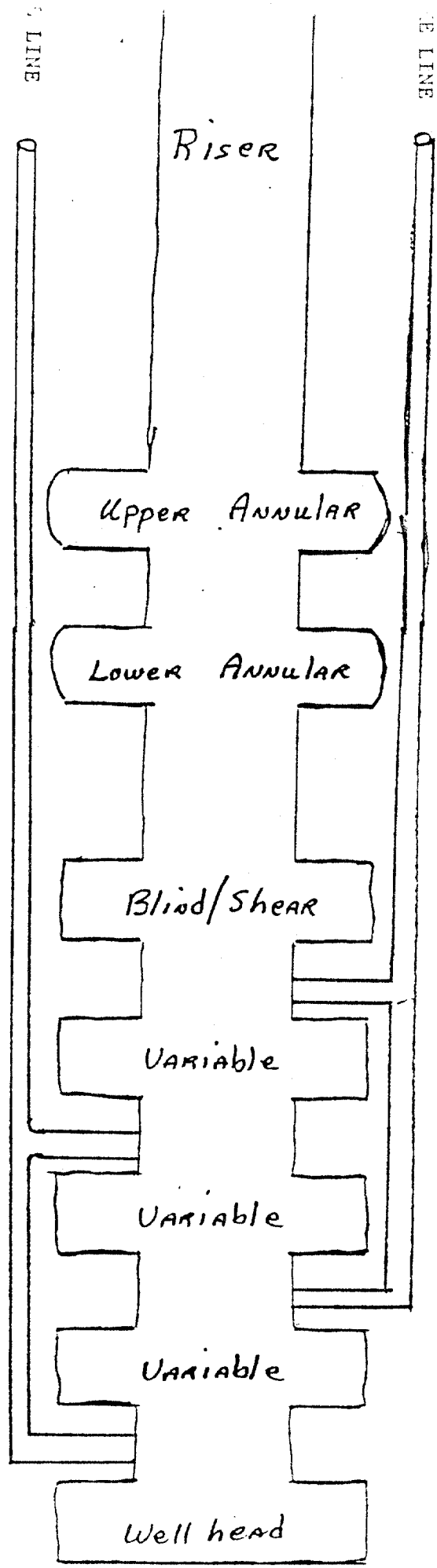

OPERATOR _____

LEASE OCS-G 4940

WELL 4 WD 750'

A/BLOCK GC-18

ID KILL LINE 3 1/2 + 3 3/8 1/2" + 5/8" Wall

ID CHOKE LINE SAME

OD RISER 21"

ID RISER 20"

COLLAPSE PRESSURE OF RISER 668# + 1335#

IN TERMS OF WATER DEPTH 1500' + 3000' 1/2" + 5/8" Wall

SIZE OF BOP STACK 18 3/4

WORKING PRESSURE OF STACK 10 m

SIZE OF DIVERTER LINES 12"

DOES RIG HAVE GUMBO BOX No

SETTING & TYPE PACK OFF ON TOP OF RISER 500# REAGAN

DOES IT REMAIN IN PLACE DURING DRILLING OPERATIONS Yes

RIG NAME Ocean Rover

DRILLING SUPT. FRANK Johnson

SUPT. TELE. NO. (504) 566-6092

IS THE FOLLOWING PROCEDURE IN THE DRILLING MANUAL Yes

PROCEDURE FOR CIRCULATING GAS OUT OF STACK AFTER KICK:

See Attached

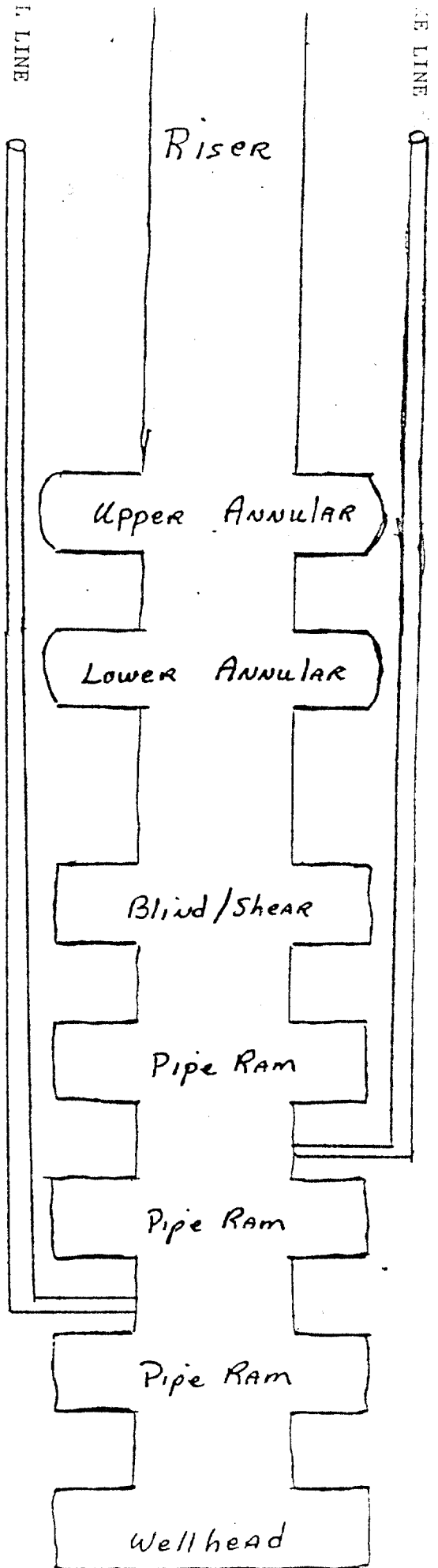

MOEPSI Drilling

SECTION

WELL CONTROL

NUMBER

8.2

SUBJECT

SUB-SEA WELL CONTROL

PURPOSE How to Handle Trapped Gas below Subsea BOP's.

REFERENCE N/A

RESPONSIBLE PERSONNEL Drilling Supervisors

PROCEDURE After handling a hydrocarbon kick with a floating rig, there is a gas bubble trapped in the BOP stack on the sea floor at pressure equal to the hydrostatic column of the kill mud. The recommended procedure for reducing the amount of gas and the pressure on the gas bubble follows:

1. Kill the well with weighted mud in the usual manner.
2. If not already closed, close the uppermost annular BOP.
3. Close the lowermost pipe rams which are located below the choke and kill lines. This is to hold bottom hole pressure constant while removing gas from the BOP stack and riser.
4. Open and circulate down through the kill line and up the choke line (uppermost connection) with unweighted gel mud until dead and stable. Circulate through the choke manifold and mud gas separator during this operation.
5. Close kill line valve.
6. Open annular BOP.
7. Bleed choke line through choke manifold and mud gas separator while filling riser with kill weight mud until dead and stable.
8. Close choke line.
9. Open and bleed kill line while filling riser with kill weight mud.
10. Circulate down kill line and out riser with kill weight mud until stable.

RWmCrackin/COMcDonald/swh/DE11967

ISSUED 9/19/84	EFFECTIVE 9/19/84	REVISION <input type="checkbox"/> COMPLETE <input type="checkbox"/> PARTIAL (see asterisk)	ISSUED BY MOEPSI PRODUCING	PAGE NO 1
SUPERSEDES NEW				

<h1>MOEPSI Drilling</h1>	SECTION	NUMBER
	WELL CONTROL	8.2
SUBJECT		
SUB-SEA WELL CONTROL		

PURPOSE How to Handle Trapped Gas below Subsea BOP's.

REFERENCE N/A

RESPONSIBLE PERSONNEL Drilling Supervisors

PROCEDURE (CONTINUED)

- 11. Close kill line.
- 12. Open pipe rams.
- 13. Circulate the hole until stable.

APPROVED: *H. J. Dvoracek* DATE 9/24/84
H. J. DVORACEK - DRILLING MANAGER

APPROVED: *K. Parsai* DATE 9/19/84
K. PARSAI - DRILLING ENGINEERING MANAGER

RWCrackin/COMcDonald/swh/DE11967

ISSUED 9/19/84	EFFECTIVE 9/19/84	REVISION <input type="checkbox"/> COMPLETE <input type="checkbox"/> PARTIAL (see asterisk)	ISSUED BY MOEPSI PRODUCING	PAGE NO. 2
SUPERSEDES NEW				

OPERATOR

LEASE OCS - G 5805

WELL 1 WD 1141

AREA/BLOCK EW-915

ID KILL LINE 3"

ID CHOKE LINE 3"

OD RISER 21"

ID RISER 20"

COLLAPSE PRESSURE OF RISER 1342

IN TERMS OF WATER DEPTH 3000

SIZE OF BOP STACK 18 3/4

WORKING PRESSURE OF STACK 10 m

SIZE OF DIVERTER LINES 12"

DOES RIG HAVE GUMBO BOX NO

WEIGHT & TYPE PACK OFF ON
TOP OF RISER 500# REAGAN

DOES IT REMAIN IN PLACE DURING
DRILLING OPERATIONS Yes

RIG NAME Ocean Endeavour

DRILLING SUPT. Nelson Burton

CONTACT TELE. NO. (504) 649-6493

DOES THE FOLLOWING PROCEDURE IN
THE DRILLING MANUAL Yes

PROCEDURE FOR CIRCULATING GAS
OUT OF STACK AFTER KICK:

See Attached

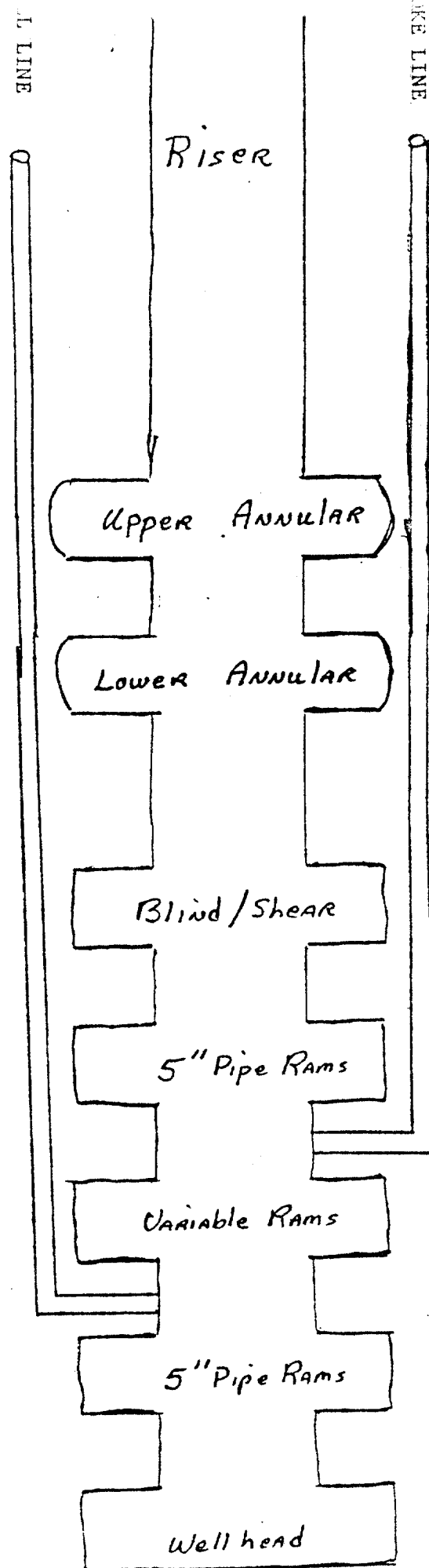

<h1>MOEPSI Drilling</h1>	SECTION	NUMBER
	WELL CONTROL	8.2
SUBJECT		
SUB-SEA WELL CONTROL		

PURPOSE How to Handle Trapped Gas below Subsea BOP's.

REFERENCE N/A

RESPONSIBLE PERSONNEL Drilling Supervisors

PROCEDURE After handling a hydrocarbon kick with a floating rig, there is a gas bubble trapped in the BOP stack on the sea floor at pressure equal to the hydrostatic column of the kill mud. The recommended procedure for reducing the amount of gas and the pressure on the gas bubble follows:

1. Kill the well with weighted mud in the usual manner.
2. If not already closed, close the uppermost annular BOP.
3. Close the lowermost pipe rams which are located below the choke and kill lines. This is to hold bottom hole pressure constant while removing gas from the BOP stack and riser.
4. Open and circulate down through the kill line and up the choke line (uppermost connection) with unweighted gel mud until dead and stable. Circulate through the choke manifold and mud gas separator during this operation.
5. Close kill line valve.
6. Open annular BOP.
7. Bleed choke line through choke manifold and mud gas separator while filling riser with kill weight mud until dead and stable.
8. Close choke line.
9. Open and bleed kill line while filling riser with kill weight mud.
10. Circulate down kill line and out riser with kill weight mud until stable.

RWMcCrackin/COMcDonald/swh/DE11967

ISSUED 9/19/84	EFFECTIVE 9/19/84	REVISION <input type="checkbox"/> COMPLETE <input type="checkbox"/> PARTIAL (see asterisk)	ISSUED BY MOEPSI PRODUCING	PAGE NO 1
SUPERSEDES NEW				

drilling procedures guide

<h2>MOEPSI Drilling</h2>	SECTION	NUMBER
	· WELL CONTROL	· 8.2
SUBJECT		
· SUB-SEA WELL CONTROL		

PURPOSE How to Handle Trapped Gas below Subsea BOP's.

REFERENCE N/A

RESPONSIBLE PERSONNEL Drilling Supervisors

PROCEDURE (CONTINUED)-

11. Close kill line.
12. Open pipe rams.
13. Circulate the hole until stable.

APPROVED: *H. V. Dvoracek* DATE 9/24/84
H. V. DVORACEK - DRILLING MANAGER

APPROVED: *K. Parsai* DATE 9/19/84
K. PARSAI - DRILLING ENGINEERING MANAGER

RWMcCrackin/COMcDonald/sw/DE11967

ISSUED 9/19/84	EFFECTIVE 9/19/84	REVISION <input type="checkbox"/> COMPLETE <input type="checkbox"/> PARTIAL (see asterisk)	ISSUED BY MOEPSI PRODUCING	PAGE N 2
SUPERSEDES NEW				

OPERATOR _____

LEASE OCS - G 5879

WELL 1 WD 1250'

AREA/BLOCK GC-21

ID KILL LINE 3.152"

ID CHOKE LINE 3.152"

OD RISER 17 7/8"

ID RISER 16 1/2"

COLLAPSE PRESSURE OF RISER 568# + 1386#
 IN TERMS OF WATER DEPTH 1270' & 3100' $1/2" + 5/8" \text{ wall}$

SIZE OF BOP STACK 16 3/4

WORKING PRESSURE OF STACK 10 m

SIZE OF DIVERTER LINES 12"

DOES RIG HAVE GUMBO BOX No

DATE & TYPE PACK OFF ON
 TOP OF RISER 500# Reagan KFDS

DOES IT REMAIN IN PLACE DURING
 DRILLING OPERATIONS Yes

RIG NAME Ben Ocean Lancer

DRILLING SUPT. Herb Kelly

TELE. NO. (504) 561-2798

IS THE FOLLOWING PROCEDURE IN
 THE DRILLING MANUAL Yes

PROCEDURE FOR CIRCULATING GAS
 OUT OF STACK AFTER KICK:
1 killed with pipe rams shut.
circulate kill mud through kill, choke, & riser,
2 rams & circulate.

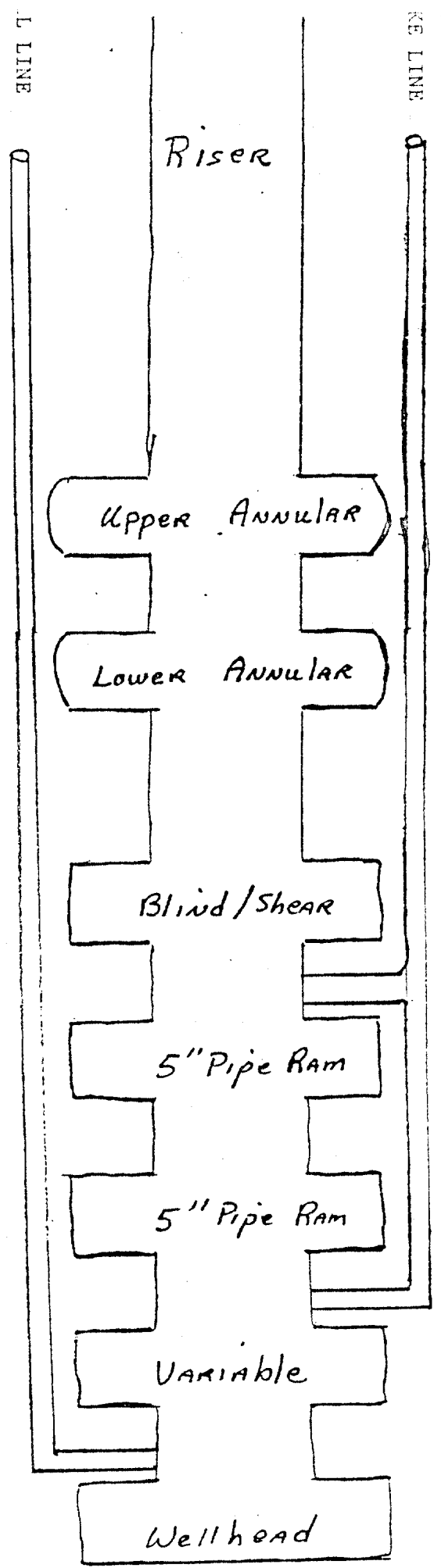

LEASE OCS-G 5882

WELL 1 WD 1653

AREA/BLOCK GC-29

ID KILL LINE 3 1/8"

ID CHOKE LINE 3 1/8"

OD RISER 20

ID RISER 19

COLLAPSE PRESSURE OF RISER 1"-2191 # 1/2"-772 #

IN TERMS OF WATER DEPTH 1"-4900' 1/8"-1726'

SIZE OF BOP STACK 20"

WORKING PRESSURE OF STACK 10 M

SIZE OF DIVERTER LINES 12"

DOES RIG HAVE GUMBO BOX No

RATING & TYPE PACK OFF ON TOP OF RISER 500# Reagan KFDS

DOES IT REMAIN IN PLACE DURING DRILLING OPERATIONS Yes

RIG NAME Penrod 73

DRILLING SUPT. Oldon Guidry

PHONE NO. (504) 868-2000 EXT. 304

IS THE FOLLOWING PROCEDURE IN THE DRILLING MANUAL Yes

PROCEDURE FOR CIRCULATING GAS OUT OF STACK AFTER KICK:

SEE Attached

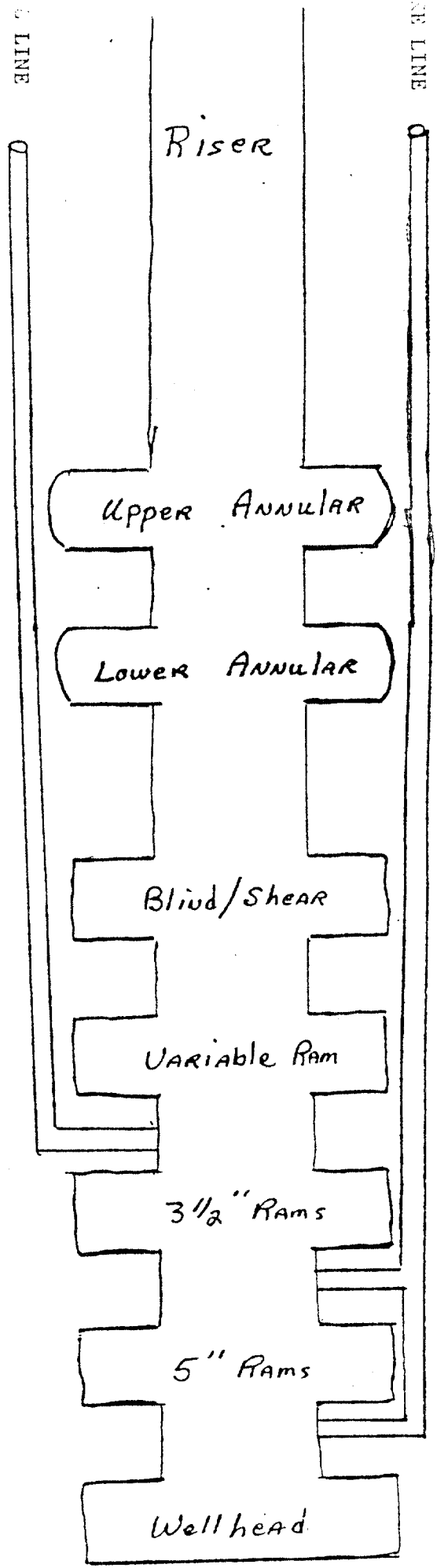

PLACID
Revised 76, 73

PLACID OIL COMPANY
SEMI-SUBMERSIBLE RIGS
SHOT IN & RISER CIRCULATING PROCEDURE

WHILE DRILLING:

1. Shut down pump(s). Pick up kelly above rotary table. *& Close T.I.W.*
2. Close riser spherical.
3. Pick up to locate tool joint against bottom of riser spherical.
4. Close top pipe rams to allow use of both choke and kill lines.
5. Record drill pipe and casing pressures.
6. Circulate out kick using predetermined procedures.
7. After well is dead, close bottom pipe rams and open top pipe rams.
8. Bleed off any trapped pressure through choke line.
9. Displace kill line with ^{gel} ~~sea~~ water by pumping down kill and out choke line.
10. Close choke valves, leave kill line open to return to mud-gas separator.
11. Line up pump to fill up line and open riser spherical allowing mud to u-tube into kill line while keeping riser full with mud.
12. After fluid level stops falling in riser, close riser spherical and pump kill mud down choke line and out kill line.
13. Open riser spherical and displace riser with kill mud.
14. Be prepared to close diverter. Some rigs are equipped with diverter systems that allow returns through the mud-gas separator. If so, close diverter before circulating out riser.

Killing Riser

WHILE TRIPPING:

1. Install TIW valve. Close TIW valve and riser spherical.
2. Install kelly. Open TIW valve as instructed.
3. Pick up to locate tool joint against bottom of riser spherical.
4. Close top pipe rams to allow use of both choke and kill lines.
5. Record drill pipe and casing pressures.

OPERATOR _____

LEASE OCS-G 5882

WELL 3 WD 1504

AREA/BLOCK GC-29

ID KILL LINE 1 7/8"

ID CHOKE LINE 1 7/8"

OD RISER 21"

ID RISER 19"

COLLAPSE PRESSURE OF RISER 772* ^{1021' 500'} 4000*

IN TERMS OF WATER DEPTH 1726' 8945'

SIZE OF BOP STACK 18 3/4"

WORKING PRESSURE OF STACK 10 m

SIZE OF DIVERTER LINES 12"

DOES RIG HAVE GUMBO BOX No

WEIGHT & TYPE PACK OFF ON TOP OF RISER 2000# Reagan KFDs

DOES IT REMAIN IN PLACE DURING DRILLING OPERATIONS Yes

RIG NAME Penrod 77

DILLING SUPT. Oldon Guiday

PT. TELE. NO. (504) 868-2000 ext. 304

DOES THE FOLLOWING PROCEDURE IN THE DRILLING MANUAL Yes

PROCEDURE FOR CIRCULATING GAS OUT OF STACK AFTER KICK:

~~same as Penrod 72~~
~~5882 #2 GC-29~~

See Attached

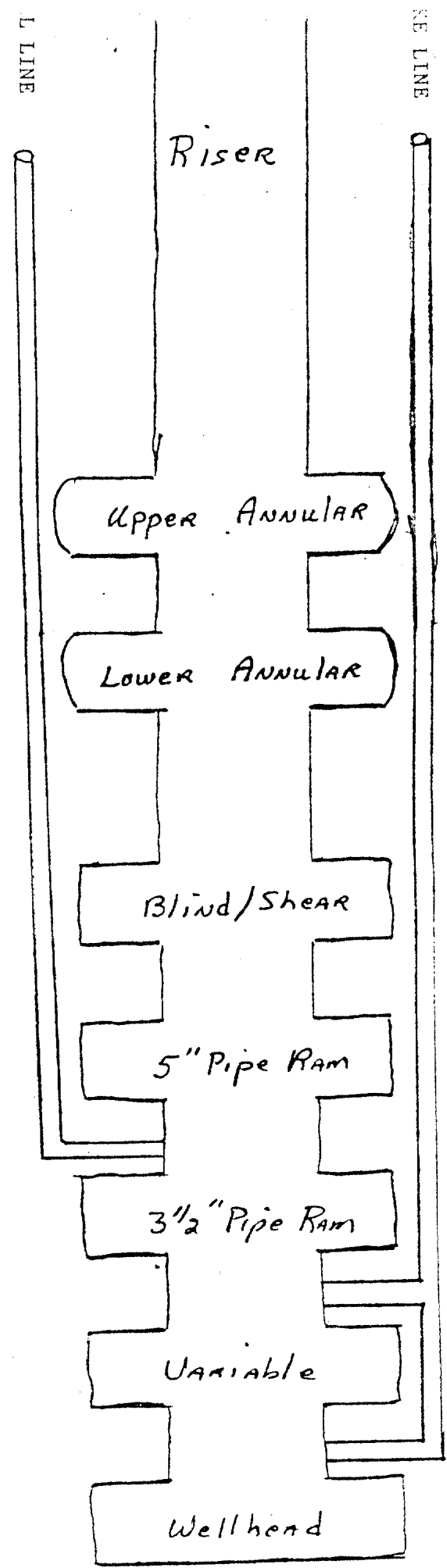

Perrod 76, 73

PLACID OIL COMPANY
SEMI-SUBMERSIBLE RIGS
SHUT IN & RISER CIRCULATING PROCEDURE

WHILE DRILLING:

1. Shut down pump(s).-- Pick up kelly above rotary table. *close T.I.W.*
2. Close riser spherical.
3. Pick up to locate tool joint against bottom of riser spherical.
4. Close top pipe rams to allow use of both choke and kill lines.
5. Record drill pipe and casing pressures.
6. Circulate out kick using predetermined procedures.
7. After well is dead, close bottom pipe rams and open top pipe rams.
8. Bleed off any trapped pressure through choke line.
9. Displace kill line with ^{gel} ~~sea~~ water by pumping down kill and out choke line.
10. Close choke valves, leave kill line open to return to mud-gas separator.
11. Line up pump to fill up line and open riser spherical allowing mud to u-tube into kill line while keeping riser full with mud.
12. After fluid level stops falling in riser, close riser spherical and pump kill mud down choke line and out kill line.
13. Open riser spherical and displace riser with kill mud.
14. Be prepared to close diverter. Some rigs are equipped with diverter systems that allow returns through the mud-gas separator. If so, close diverter before circulating out riser.

WHILE TRIPPING:

1. Install TIW valve. Close TIW valve and riser spherical.
2. Install kelly. Open TIW valve as instructed.
3. Pick up to locate tool joint against bottom of riser spherical.
4. Close top pipe rams to allow use of both choke and kill lines.
5. Record drill pipe and casing pressures.

OPERATOR 177012
 LEASE OCS-G 5882
 WELL 1 WD 1653
 AREA/BLOCK GC-29
 ID KILL LINE 3 1/8"
 ID CHOKE LINE 3 1/8"
 OD RISER 20
 ID RISER 19
 COLLAPSE PRESSURE OF RISER 1"-2191 # 1/2"-772 #
 IN TERMS OF WATER DEPTH 1"-4900' 1/2"-1726'
 SIZE OF BOP STACK 20"
 WORKING PRESSURE OF STACK 10 M
 SIZE OF DIVERTER LINES 12"
 DOES RIG HAVE GUMBO BOX No
 RATING & TYPE PACK OFF ON
 TOP OF RISER 500# REAGAN KFDS
 DOES IT REMAIN IN PLACE DURING
 DRILLING OPERATIONS Yes
 RIG NAME Penrod 73
 DRILLING SUPT. Oldon Guidry
 SUPT. TELE. NO. (504) 868-2000 EXT. 304
 IS THE FOLLOWING PROCEDURE IN
 THE DRILLING MANUAL Yes
 PROCEDURE FOR CIRCULATING GAS
 OUT OF STACK AFTER KICK:
SEE ATTACHED

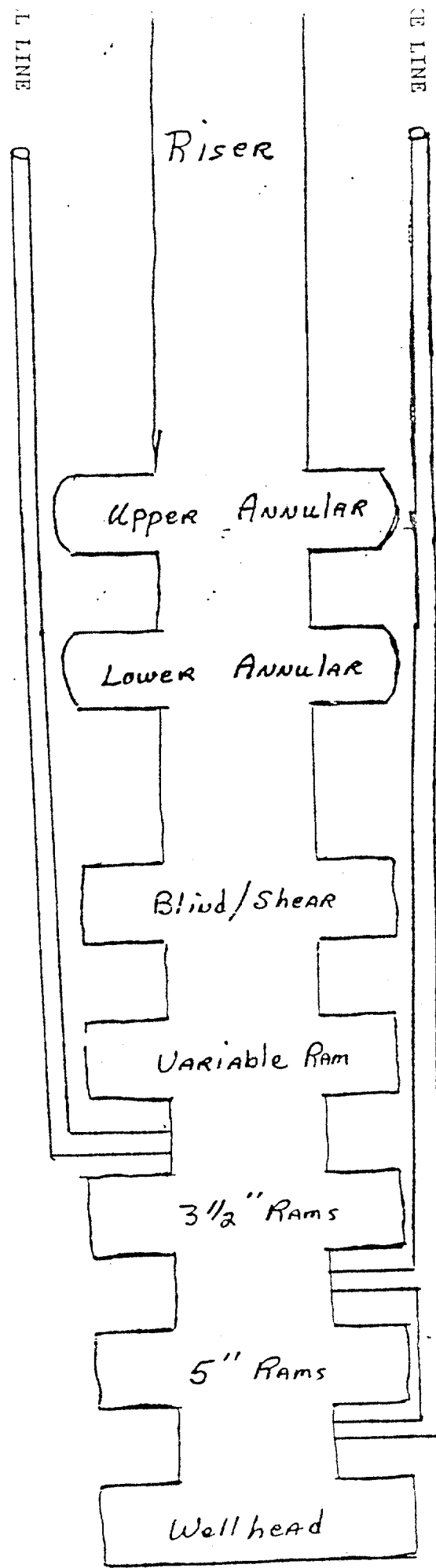

FLACID
Period 76, 73

FLACID OIL COMPANY
SEMI-SUBMERSIBLE RIGS
SHUT IN & RISER CIRCULATING PROCEDURE

WHILE DRILLING:

1. Shut down pump(s). Pick up kelly above rotary table. ← Close T.I.W.
2. Close riser spherical.
3. Pick up to locate tool joint against bottom of riser spherical.
4. Close top pipe rams to allow use of both choke and kill lines.
5. Record drill pipe and casing pressures.
6. Circulate out kick using predetermined procedures.
7. After well is dead, close bottom pipe rams and open top pipe rams.
8. Bleed off any trapped pressure through choke line.
9. Displace kill line with ^{gel} ~~sea~~ water by pumping down kill and out choke line.
10. Close choke valves, leave kill line open to return to mud-gas separator.
11. Line up pump to fill up line and open riser spherical allowing mud to u-tube into kill line while keeping riser full with mud.
12. After fluid level stops falling in riser, close riser spherical and pump kill mud down choke line and out kill line.
13. Open riser spherical and displace riser with kill mud.
14. Be prepared to close diverter. Some rigs are equipped with diverter systems that allow returns through the mud-gas separator. If so, close diverter before circulating out riser.

Killing Riser

WHILE TRIPPING:

1. Install TIW valve. Close TIW valve and riser spherical.
2. Install kelly. Open TIW valve as instructed.
3. Pick up to locate tool joint against bottom of riser spherical.
4. Close top pipe rams to allow use of both choke and kill lines.
5. Record drill pipe and casing pressures.

LEASE OCS-G 5882

WELL 2 WD 1653

AREA/BLOCK GC-29

ID KILL LINE 2 1/4"

ID CHOKE LINE 2 1/4"

ID RISER 20

ID RISER 18 3/4

COLLAPSE PRESSURE OF RISER 772#

IN TERMS OF WATER DEPTH 1726

SIZE OF BOP STACK 18 3/4

WORKING PRESSURE OF STACK 10 m

SIZE OF DIVERTER LINES 8"

DOES RIG HAVE GUMBO BOX No

ATING & TYPE PACK OFF ON
TOP OF RISER 2000# Reagan KFDS

SHOULD IT REMAIN IN PLACE DURING
DRILLING OPERATIONS Yes

PIPE NAME Penrod 72

DRILLING SUPT. Oldon Guidry

OFFICE TELE. NO. (504) 868-2000 ext. 304

IS THE FOLLOWING PROCEDURE IN
THE DRILLING MANUAL Yes

PROCEDURE FOR CIRCULATING GAS
OUT OF STACK AFTER KICK:

*bottom pipe RAMS & open top pipe RAMS.
relieve any trapped pressure thru choke line.
fill choke & kill line with gal water by pumping
down choke & out of kill.
fill choke line with kill mud. Close choke valve
open kill to mud gas separator.
run pump to fill line & open riser spherical
allowing mud to u-tube into kill line while
keeping riser full.
fill riser with kill mud.*

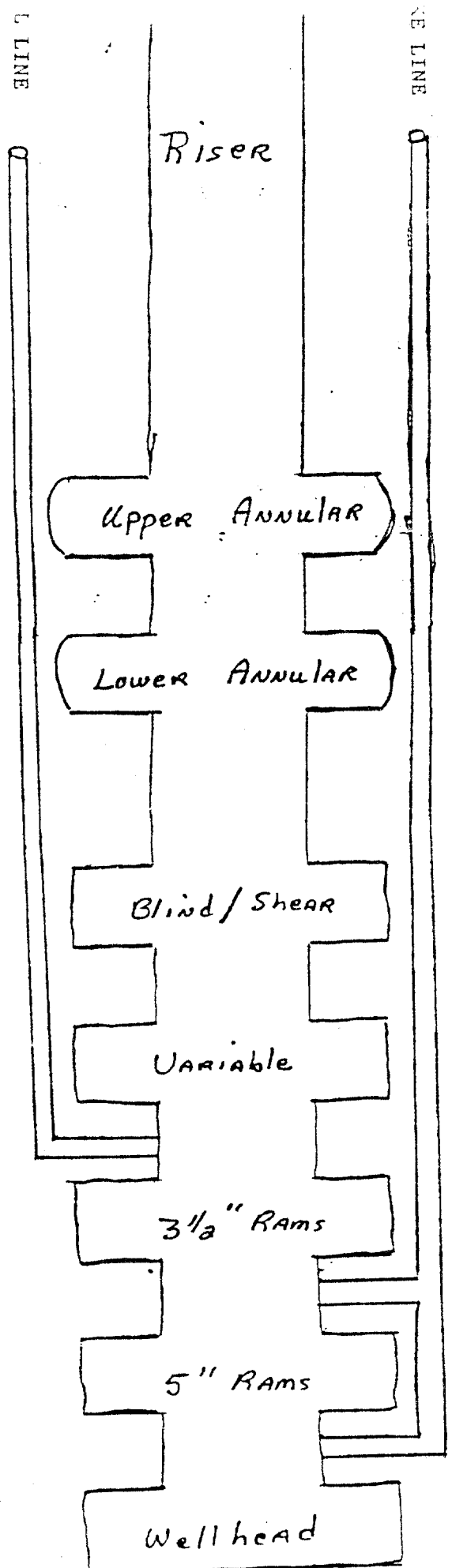

LEASE OCS - G 6994

WELL 3 WD 1990'

BLOCK GC - 31

ID KILL LINE 3"

ID CHOKE LINE 3"

OD RISER Upper - 20"
Lower - 21" - 11jts

ID RISER 19" Tube 18 3/4 Conn.

COLLAPSE PRESSURE OF RISER 914

IN TERMS OF WATER DEPTH 2044

SIZE OF BOP STACK 18 3/4

WORKING PRESSURE OF STACK 10m

SIZE OF DIVERTER LINES 12"

DOES RIG HAVE GUMBO BOX NO

ATING & TYPE PACK OFF ON
TOP OF RISER 500* Reagan KFDS

IT REMAIN IN PLACE DURING
DRILLING OPERATIONS Yes

IG NAME Penrod #76

ILLING SUPT. Oldon Guiday

PT. TELE. NO. (504) 868-2000 Ext.-304

THE FOLLOWING PROCEDURE IN
THE DRILLING MANUAL Yes

PROCEDURE FOR CIRCULATING GAS
OUT OF STACK AFTER KICK:

See Attached

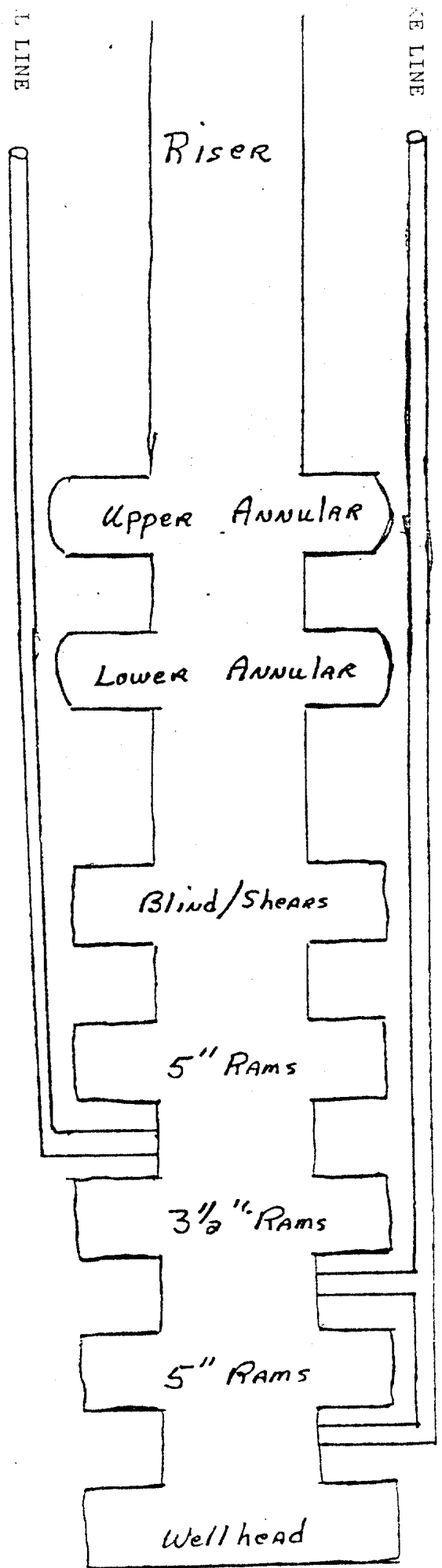

Penrod 76, 73

PLACID OIL COMPANY
SEMI-SUBMERSIBLE RIGS
SHUT IN & RISER CIRCULATING PROCEDURE

WHILE DRILLING:

1. Shut down pump(s). Pick up kelly above rotary table. *← close T.I.W.*
2. Close riser spherical.
3. Pick up to locate tool joint against bottom of riser spherical.
4. Close top pipe rams to allow use of both choke and kill lines.
5. Record drill pipe and casing pressures.
6. Circulate out kick using predetermined procedures.
7. After well is dead, close bottom pipe rams and open top pipe rams.
8. Bleed off any trapped pressure through choke line.
9. Displace kill line with ^{aq}~~sea~~ water by pumping down kill and out choke line.
10. Close choke valves, leave kill line open to return to mud-gas separator.
11. Line up pump to fill up line and open riser spherical allowing mud to u-tube into kill line while keeping riser full with mud.
12. After fluid level stops falling in riser, close riser spherical and pump kill mud down choke line and out kill line.
13. Open riser spherical and displace riser with kill mud.
14. Be prepared to close diverter. Some rigs are equipped with diverter systems that allow returns through the mud-gas separator. If so, close diverter before circulating out riser.

WHILE TRIPPING:

1. Install TIW valve. Close TIW valve and riser spherical.
2. Install kelly. Open TIW valve as instructed.
3. Pick up to locate tool joint against bottom of riser spherical.
4. Close top pipe rams to allow use of both choke and kill lines.
5. Record drill pipe and casing pressures.

OPERATOR _____

LEASE OCS - G 7034

WELL 1 WD 2460'

AREA/BLOCK GC - 199

ID KILL LINE 3"

ID CHOKE LINE 3"

ID RISER 20"

ID RISER 19"

COLLAPSE PRESSURE OF RISER 700#

IN TERMS OF WATER DEPTH 1550'

SIZE OF BOP STACK 18 3/4

WORKING PRESSURE OF STACK 10 m

SIZE OF DIVERTER LINES 12"

DOES RIG HAVE GUMBO BOX No

DATE & TYPE PACK OFF ON
TOP OF RISER 750# REAGAN

DOES IT REMAIN IN PLACE DURING
DRILLING OPERATIONS Yes

RIG NAME Penrod 78

DRILLING SUPT. Oldon Guiday

SUPT. TELE. NO. (504) 868-4473

IS THE FOLLOWING PROCEDURE IN
THE DRILLING MANUAL Yes

PROCEDURE FOR CIRCULATING GAS
OUT OF STACK AFTER KICK:

See Attached

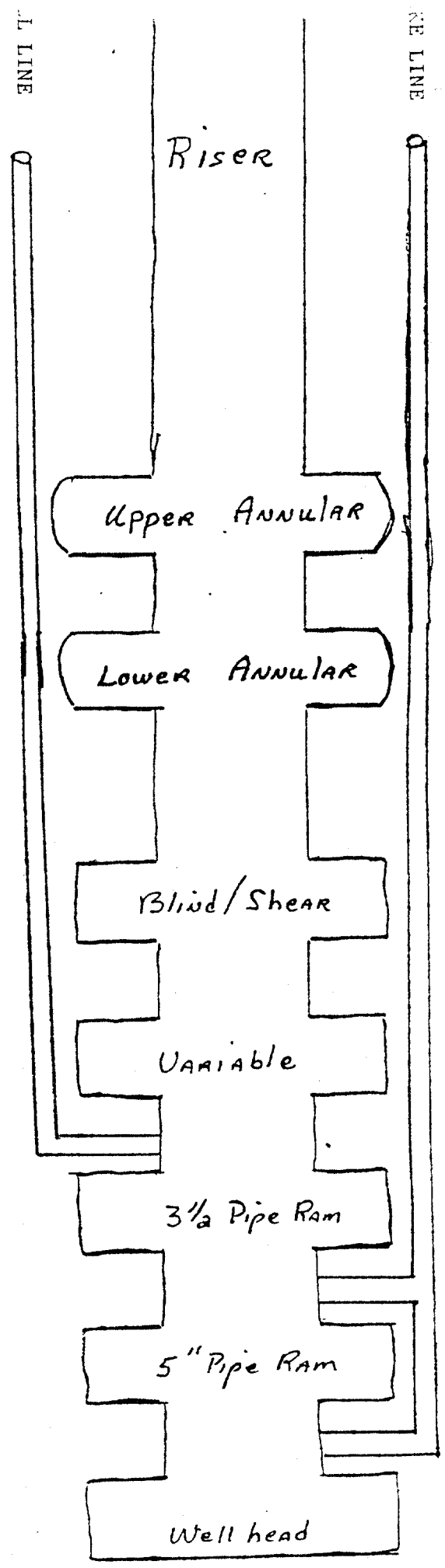

Penrod 76, 73

PLACID OIL COMPANY
SEMI-SUBMERSIBLE RIGS
SHUT IN & RISER CIRCULATING PROCEDURE

WHILE DRILLING:

1. Shut down pump(s). Pick up kelly above rotary table. *& close T.I.W.*
2. Close riser spherical.
3. Pick up to locate tool joint against bottom of riser spherical.
4. Close top pipe rams to allow use of both choke and kill lines.
5. Record drill pipe and casing pressures.
6. Circulate out kick using predetermined procedures.
7. After well is dead, close bottom pipe rams and open top pipe rams.
8. Bleed off any trapped pressure through choke line.
9. Displace kill line with ^{gel} water by pumping down kill and out choke line.
10. Close choke valves, leave kill line open to return to mud-gas separator.
11. Line up pump to fill up line and open riser spherical allowing mud to u-tube into kill line while keeping riser full with mud.
12. After fluid level stops falling in riser, close riser spherical and pump kill mud down choke line and out kill line.
13. Open riser spherical and displace riser with kill mud.
14. Be prepared to close diverter. Some rigs are equipped with diverter systems that allow returns through the mud-gas separator. If so, close diverter before circulating out riser.

WHILE TRIPPING:

1. Install TIW valve. Close TIW valve and riser spherical.
2. Install kelly. Open TIW valve as instructed.
3. Pick up to locate tool joint against bottom of riser spherical.
4. Close top pipe rams to allow use of both choke and kill lines.
5. Record drill pipe and casing pressures.

Operator: SHELL OFFSHORE
 OCS Lease: G 6886
 Well No.: 1
 Area/Block: Viosca Knoll 783
 Water Depth: 1445 ft.
 ID of Kill line: 2-3/4 in.
 ID of Choke line: 2-3/4 in.
 OD of Riser: 19 in. (estimated)
 ID of Riser: 17-1/4 in.
 Collapse Pressure of Riser: unk. psi
 In Terms of Water Depth: unk. psi
 Size of BOP Stack: 16-3/4 in.
 WP of Stack: 10000 psi (5000 annular)
 Size of Diverter lines: 14 in.
 Rig has Gumbo Box? Yes
 No
 Rating and Type PO on top of
 Riser: 100psi-Regan KFD
 Rig Name: DISCOVERER 534
 Drilling Supt.: Ike Broussard
 Supt. Tel. No.: (504) 588-7930
 (504) 588-7987
 Procedure for Circulating Gas Out of Stack
 After a Kick:
Use riser flush line to pump out riser w/
kill mud & BOPs closed; pump out stack w/
ck ln; expel kick thru rotary or diverter
 Is Procedure In Drilling Manual? Yes
 Presently under preparation No

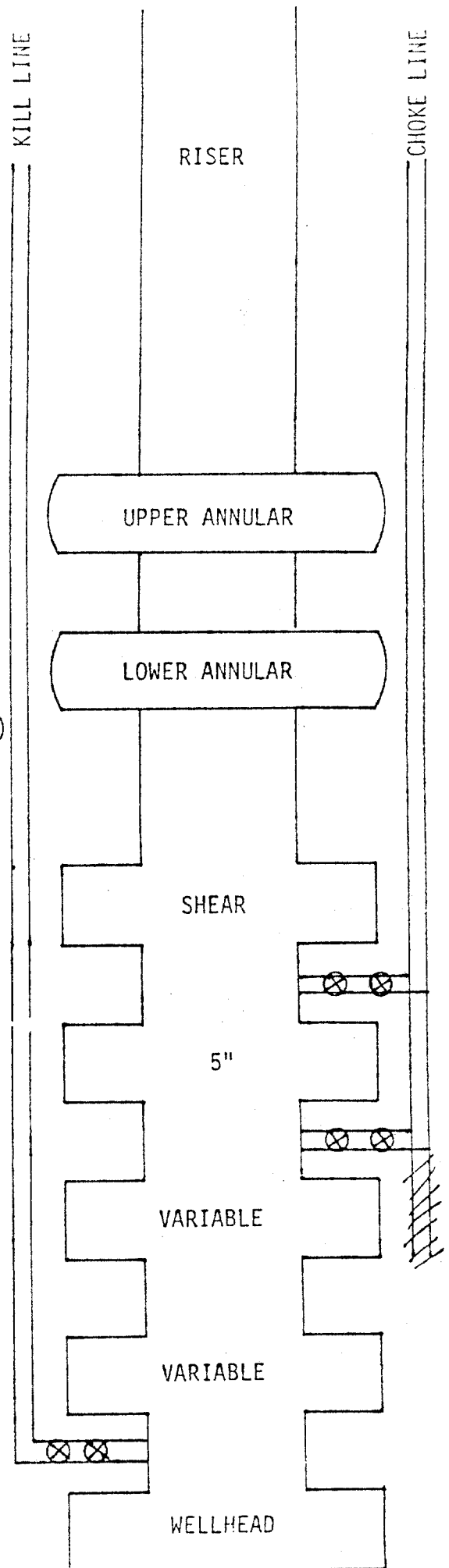

- 1) Extend choke and kill lines-show outlets on location
- 2) Label rams - pipe, variable, blind/shear

OPERATOR _____

LEASE OCS - G 5900

WELL 2 WD 1580'

A/BLOCK GC - 109'

ID KILL LINE 2 3/4"

ID CHOKE LINE 2 3/4"

OD RISER 18.63"

ID RISER 17.25"

COLLAPSE PRESSURE OF RISER 2146 #

IN TERMS OF WATER DEPTH 4800'

SIZE OF BOP STACK 16 3/4"

WORKING PRESSURE OF STACK 10 m

SIZE OF DIVERTER LINES 14"

DOES RIG HAVE GUMBO BOX No

DATING & TYPE PACK OFF ON TOP OF RISER 250 # Reagan

DO THEY REMAIN IN PLACE DURING DRILLING OPERATIONS Yes

RIG NAME Discoverer 534

DRILLING SUPT. John Hellings

SUPT. TELE. NO. (504) 588-4010

IS THE FOLLOWING PROCEDURE IN THE DRILLING MANUAL Yes

PROCEDURE FOR CIRCULATING GAS OUT OF STACK AFTER KICK:

Close RAMS below choke line and open indicator. Slowly open ANNULAR and allow gas to rise to the surface. Displace gas with kill mud and reopen RAMS.

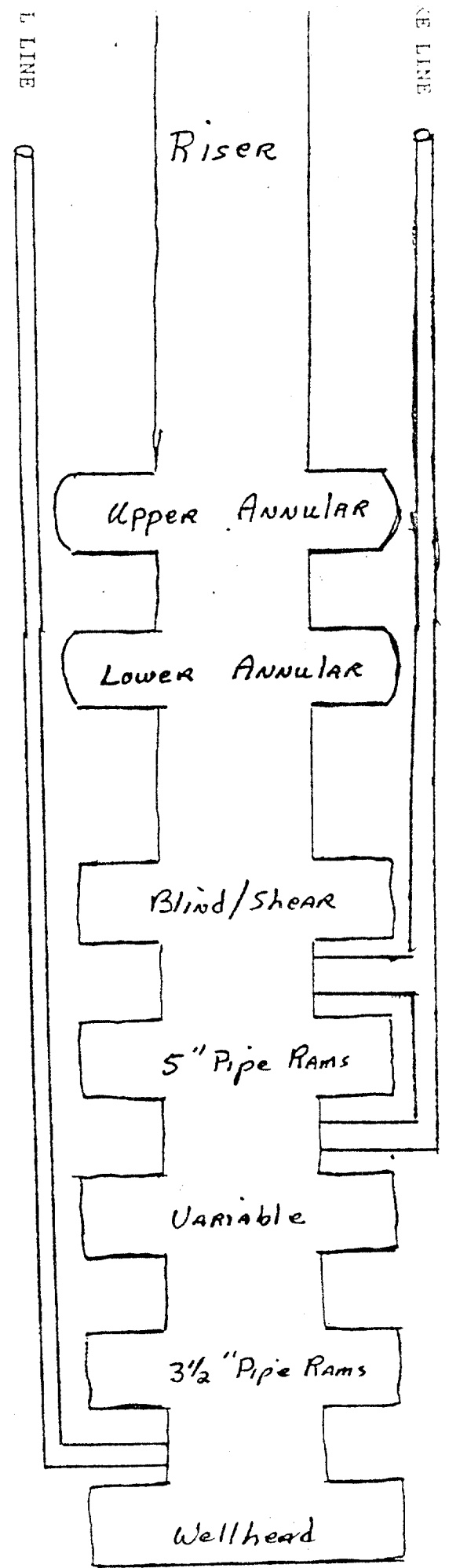

OPERATOR _____

LEASE OCS-G 5888

WELL 2 WD 950'

LA/BLOCK GC-60

ID KILL LINE 2 1/2"

ID CHOKE LINE 2 1/2"

OD RISER 21"

ID RISER 20 1/2"

COLLAPSE PRESSURE OF RISER 656 #

IN TERMS OF WATER DEPTH 1466'

SIZE OF BOP STACK 18 3/4

WORKING PRESSURE OF STACK 10 m

SIZE OF DIVERTER LINES 10"

DOES RIG HAVE GUMBO BOX No

RATING & TYPE PACK OFF ON TOP OF RISER 1000# Reagan KFDH

DOES IT REMAIN IN PLACE DURING DRILLING OPERATIONS Yes

RIG NAME Diamond M "New ERA"

DRILLING SUPT. Jim Parker

SUPT. TELE. NO. (318) 981-9483

IS THE FOLLOWING PROCEDURE IN THE DRILLING MANUAL No

PROCEDURE FOR CIRCULATING GAS OUT OF STACK AFTER KICK:

*1) Riser with kill wt. mud.
2) Displace choke & kill lines with water
3) Pump down kill & out choke line. AFTER
All gas is circulated out, displace
with kill mud.
4) Open Annular with low operating pressure.*

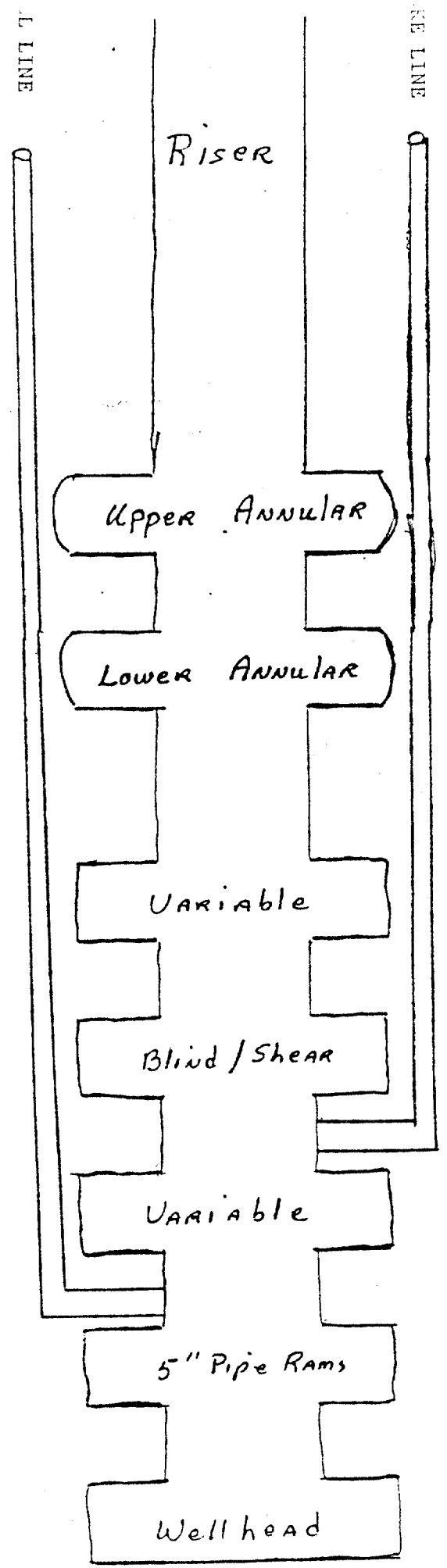

OPERATOR: SOHIO PETROLEUM CO
 LEASE : CCS G 6280 #2
 AREA & BLK. EB 165 WATER DEPTH 996
 ID KILL LINE: 3"
 ID CHOKE LINE: 3"
 OD RISER : 21 = 1/2" WT
 ID RISER : 20

COLLAPSE PRESSURE OF RISER: UNKNOWN @ RIG - STATED
 (in terms of water depth) GOOD TO RIG RATED DEPTH
 OF 1300'

SIZE OF BOP STACK: 18 3/4" - 10M
 SIZE OF DIVERTOR LINES: 8" ID

DOES RIG HAVE GUMBO BOX ? NO

RATING AND TYPE DP ON TOP REGAN 500 psi
 OF RISER :

RIG NAME: DIAMOND M CENTURY

DRILLING SUPT: R.N. RAWLS
 SUPT. TELE. NO. 46 0M - MORGAN CITY

Procedure for circulating gas out of stack after kick;

CLOSE #4 PIPE - PUMP SALT WATER
 DOWN KILL & UP CHOKE LINES
 WITH ANNULAR CLOSED - WORK OUT
 GAS - THEN PUMP KILL WT. MUD
 AS ABOVE - THEN OPEN ANNULAR
 AND DISPLACE RISER WITH KILL
 WT. MUD THEN OPEN #4 PIPE
 RAM.

Is procedure in drilling manual, NO

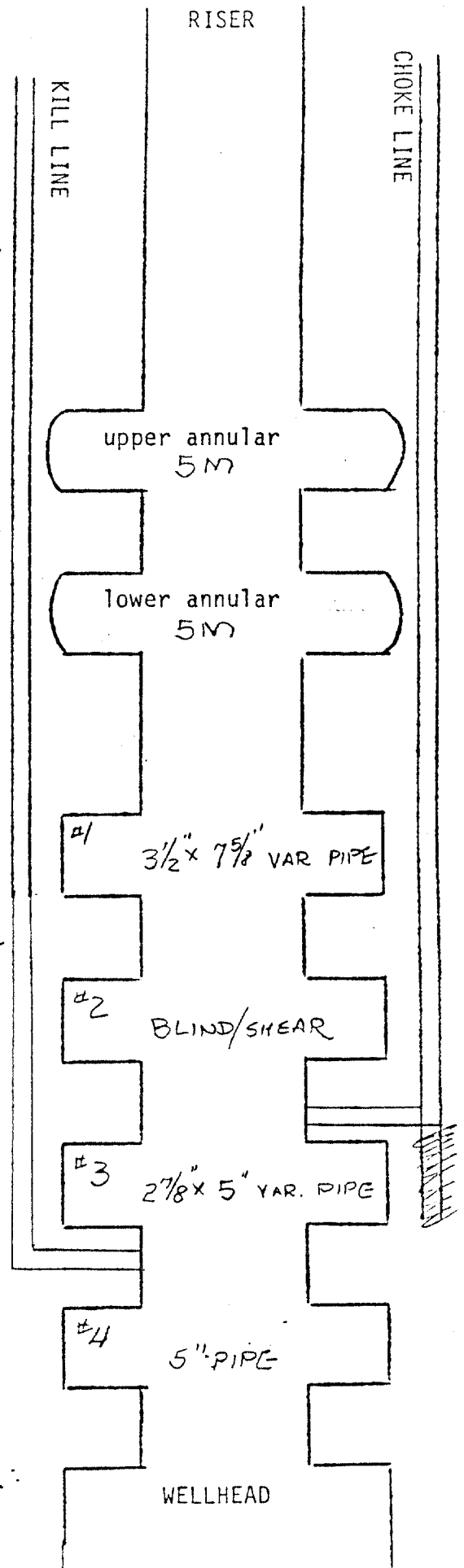

Operator: SOHIO PETROLEUM

OCS Lease: G 5826

Well No.: 3

Area/Block: Miss. Canyon 110

Water Depth: 1277 ft.

ID of Kill line: 3 in.

ID of Choke line: 3 in.

OD of Riser: 20 in.

ID of Riser: 19 in.

Collapse Pressure of Riser: unk psi

In Terms of Water Depth: unk psi

Size of BOP Stack: 18-3/4 in.

WP of Stack: 10000 (5000 anu) psi

Size of Diverter lines: 12 in.

w/750 series flanges

Rig has Gumbo Box? Yes
 No

Rating and Type PO on top of
Riser: Regan KFDS
1000 psi closing pressure

Rig Name: PACESETTER III (rated for 1500'WD)

Drilling Supt.: Ray White

Supt. Tel. No.: (504) 534-9698
(504) 534-7746

Procedure for Circulating Gas Out of Stack
After a Kick:

Close bottom variables; circ thru choke &
kill to gas buster; then choke annular to
check for flow through diverter system

Is Procedure In Drilling Manual? Yes
 No

- 1) Extend choke and kill lines-show outlets on location
- 2) Label rams - pipe, variable, blind/shear

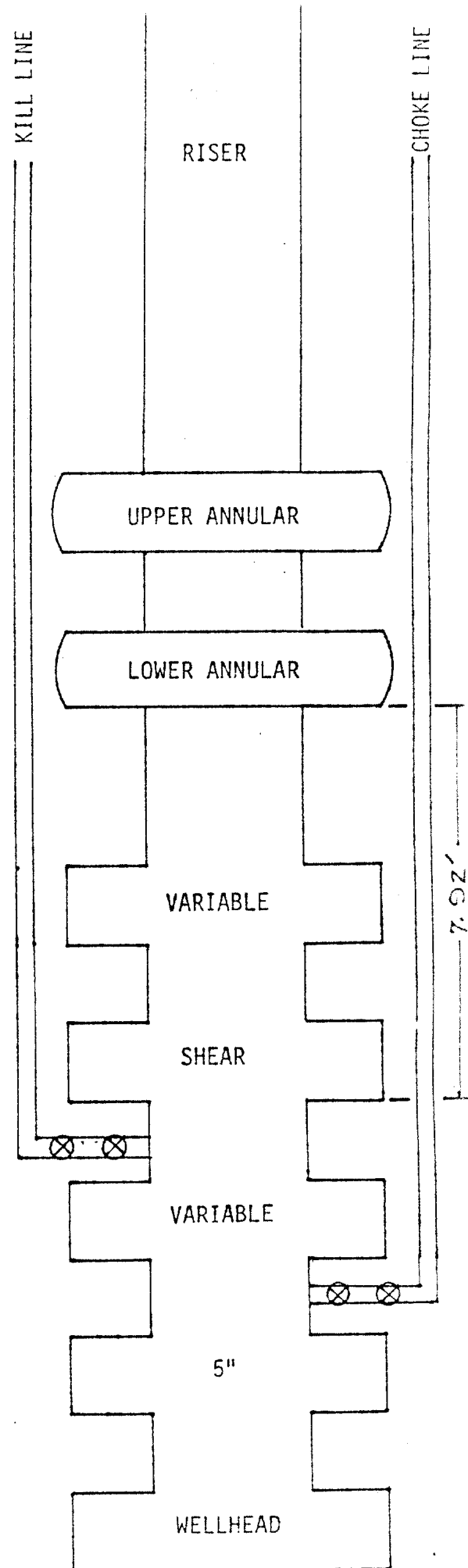

OPERATOR: TEXACO INC
 LEASE : OCS-G 6283 WD 503
 AREA & BLK. EB 172
 ID KILL LINE:
 ID CHOKE LINE: 3" ID
 OD RISER : 16"
 ID RISER : 14 3/4" 5/8 WT .625

COLLAPSE PRESSURE OF RISER: 1420
 (in terms of water depth)

SIZE OF BOP STACK: 13 5/8 10 M
 SIZE OF DIVERTOR LINES: 10" ID

DOES RIG HAVE GUMBO BOX ? NO KFDS

RATING AND TYPED P ON TOP REGAN 37 1/2
 OF RISER : 500 psi

RIG NAME: OCEAN DRILLER

DRILLING SUPT: DENNY DUCKER
 SUPT. TELE. NO. 504-361-2811

Procedure for circulating gas out of stack
 after kick; (1) CLOSE LOWEST PIPE RAM
 (2) CIRCULATE FRESH WATER DOWN KILL
 LINE, TAKE RETURNS ON CHOKE LINE THRU
 CHOKE MANIFOLD TILL WATER BACK TO
 SURFACE.

(3) LINE RIG PUMP UP ON FILL UP LINE w/ mud

(4) OPEN ADJUSTABLE CHOKE FULL OPEN ON CHOKE LINE AT MANIFOLD

(5) BACK OFF ANNULAR REGULATOR PRESSURE TO ALLOW ANNULAR PREV. TO SLOWLY OPEN (OVER)

Is procedure in drilling manual, NO ABOVE

OLDER METHOD
 IN MANUAL

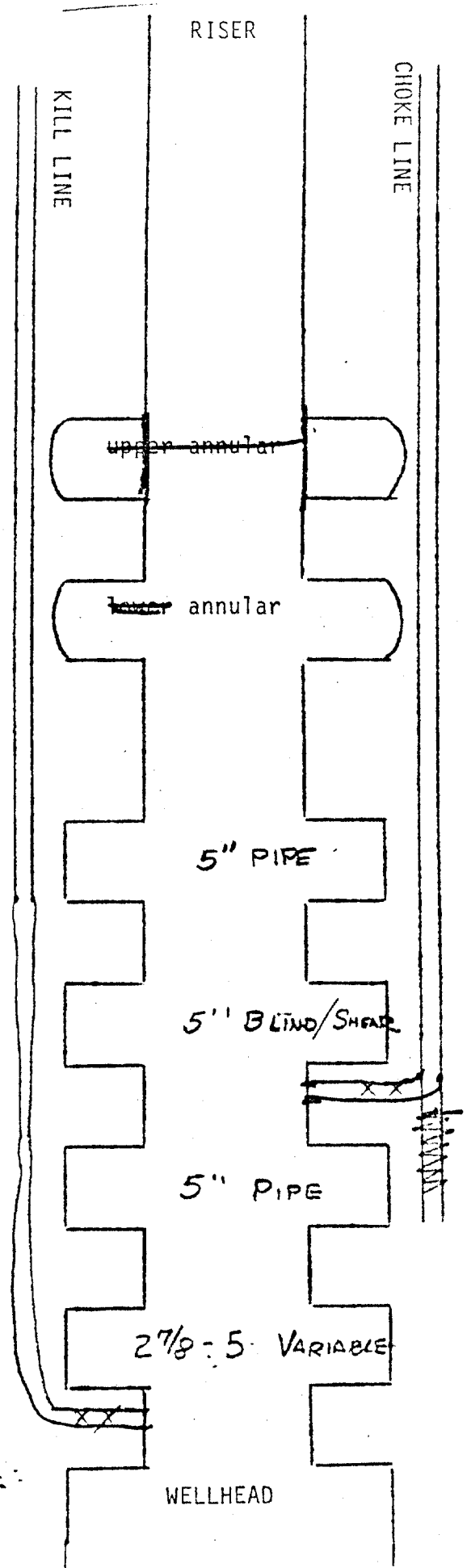

START RIG PUMP ON FILL UP LINE TO KEEP RISER FULL. AS
MUD U-TUBES DOWN RISER AND UP CHOKE LINE, FLUSH GAS OUT.
WHEN MUD RETURN ARE BACK TO SURFACE, STOP RIG PUMPS
v FILL UP LINE, CLOSE CHOKE LINE

LINE RIG PUMP UP TO KILL LINE, DISPLACE RISER w/
KILL WT MUD

OPEN LOWEST PIPE RAMS, CONTINUE CIRCULATION FOR
TRIP MARGIN OR TO DRILL AHEAD.

kill rate. In the subsea stack operation the casing pressure is reduced by a value equal to the pre-determined choke line pressure loss and held at this reduced pressure value until the pumps are at the pre-determined kill rate.

c. After Circulation of Kill Weight Mud

After the kill weight mud has been circulated and the drill pipe and choke line register zero pressure, the annular BOP cannot be opened until the light mud in the riser is circulated out. This can be accomplished with most subsea BOP stacks by closing the lower pipe rams, then opening the annular preventer and circulating kill weight mud down the choke line with returns up the riser. Caution - There is always a possibility that trapped gas exists under the annular BOP. This trapped gas will unload mud from the riser. There are acceptable methods for removing the gas trapped between the choke line outlet in the stack and the options should be discussed with the Assistant Manager on duty.

CURRENT
TO BE
REVISED
AS
WRITTEN
ON SURVEY
SHEET.

OPERATOR: TEXACO INC
 LEASE : G-6265
 AREA & BLK. HI-A-402
 ID KILL LINE: 3/16
 ID CHOKE LINE: 3/16
 OD RISER : 21"
 ID RISER : 20" & 19 3/4"

WD. 508

COLLAPSE PRESSURE OF RISER: 2419' FOR THE 5/8" RISER
 (in terms of water depth) * 1210' FOR THE 1/2" RISER

SIZE OF BOP STACK: 18 3/4" - 10M
 SIZE OF DIVERTOR LINES: 12"

DOES RIG HAVE GUMBO BOX ? NO

RATING AND TYPED P ON TOP 500# - REAGAN KFD
 OF RISER :

RIG NAME: BLUEWATER IV

DRILLING SUPT: EVERETT BENNETT
 SUPT. TELE. NO. 318-984-1112

Procedure for circulating gas out of stack
 after kick; SEE NEXT PAGE

Is procedure in drilling manual, YES

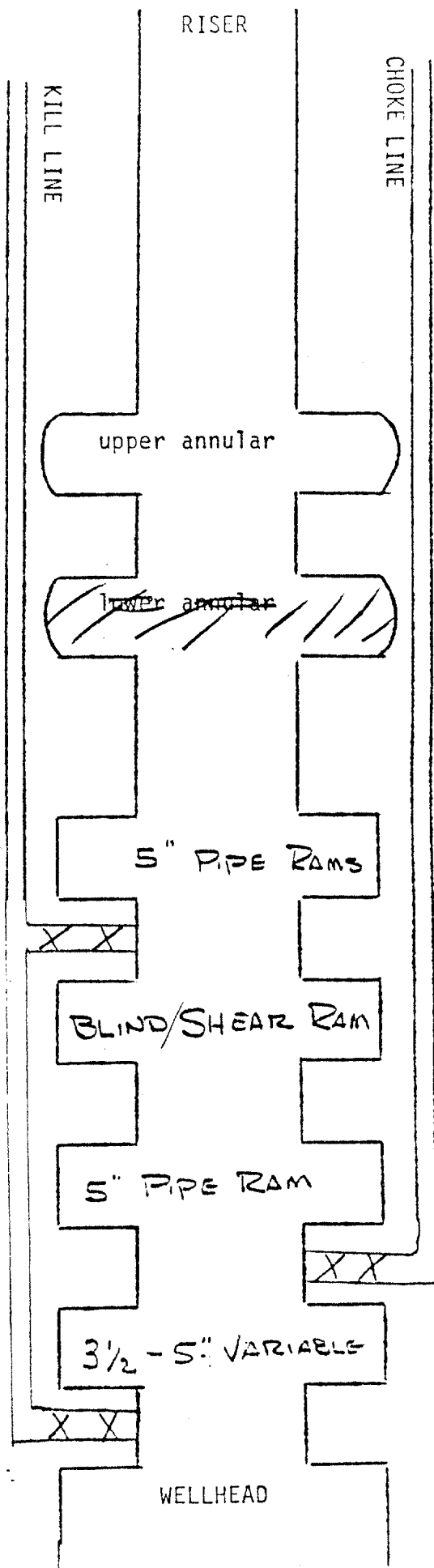

choke line. The pressure compensation is made at the time the initial pumping rate is being established. In a surface stack operation the casing pressure is held constant at the SICP value until the pumps are at the pre-determined kill rate. In the subsea stack operation the casing pressure is reduced by a value equal to the pre-determined choke line pressure loss and held at this reduced pressure value until the pumps are at the pre-determined kill rate.

c. After Circulation of Kill Weight Mud

After the kill weight mud has been circulated and the drill pipe and choke line register zero pressure, the annular BOP cannot be opened until the light mud in the riser is circulated out. This can be accomplished with most subsea BOP stacks by closing the lower pipe rams, then opening the annular preventer and circulating kill weight mud down the choke line with returns up the riser. Caution - There is always a possibility that trapped gas exists under the annular BOP. This trapped gas will unload mud from the riser. There are acceptable methods for removing the gas trapped between the choke line outlet in the stack and the annular BOP prior to opening the annular BOP. These options should be discussed with the Assistant Manager on duty.