

Factors affecting the performance of the optical plankton counter in large lakes: Insights from Lake Michigan and laboratory studies

James R. Liebig,¹ Henry A. Vanderploeg,¹ and Steven A. Ruberg¹

Received 2 June 2005; revised 18 October 2005; accepted 24 October 2005; published 18 March 2006.

[1] There has been a question as to whether the optical plankton counter (OPC) accurately measures zooplankton density and biomass in large lakes, oceans, and estuaries. Results from our Lake Michigan surveys in 1998–2000 often revealed poor agreement between the OPC-2T and 153- μm mesh plankton net samples. The most serious common problem was overestimation of zooplankton biomass by the OPC relative to net tows. Such overestimates have been attributed to the orientation of zooplankton assuming that their maximal silhouette area is detected by the OPC, coincidence, and the presence of nonzooplankton particles. Experiments using an OPC-1L with polymer microspheres, nylon rods, or live zooplankton confirmed that the OPC accurately counts and sizes zooplankton at low zooplankton concentrations typically found in Lake Michigan and that a shape factor correction often used need not be applied. Most overestimation of biomass was associated with the presence of nonzooplankton particles. Worst agreement was seen in shallow nearshore zones during periods of high total suspended matter (TSM), which consisted of fine sediments and large resuspended particles such as sediment-phytoplankton aggregates, and benthic plant and animal debris. Best agreement was found under low TSM conditions associated with offshore waters during the stratified period.

Citation: Liebig, J. R., H. A. Vanderploeg, and S. A. Ruberg (2006), Factors affecting the performance of the optical plankton counter in large lakes: Insights from Lake Michigan and laboratory studies, *J. Geophys. Res.*, *111*, C05S02, doi:10.1029/2005JC003087.

1. Introduction

[2] The optical plankton counter (OPC) has been used by various investigators in large lakes, oceans, and estuaries for more than fifteen years now with mixed results in reconciling OPC data with plankton net data [Grant *et al.*, 2000; Halliday *et al.*, 2001; Heath *et al.*, 1999; Herman, 1988, 1992; Herman *et al.*, 1993; Huntley *et al.*, 1995; Sprules *et al.*, 1998]. Factors that are known to affect the accuracy of OPC measurements in the field include tow speed, zooplankton density (coincidence), zooplankton size and transparency, orientation of elongated zooplankton, phytoplankton blooms, marine snow or other particle aggregates, and high concentrations of background particles smaller than detection limit [Halliday *et al.*, 2001; Heath *et al.*, 1999; Herman, 1988, 1992; Sprules *et al.*, 1992; Woodd-Walker *et al.*, 2000; Zhang *et al.*, 2000].

[3] Our experience using the OPC in Lake Michigan has shown generally poor agreement between estimates of zooplankton abundance and biomass determined from a towed OPC-2T and from vertical tows of a 0.5-m-diameter, 153- μm zooplankton net. To gain insight into some of the factors that affect OPC performance in large lakes, labora-

tory experiments were carried out using an OPC-1L in a circulation system with polystyrene spheres, nylon rods, or live zooplankton. Our main objectives were to verify that the OPC measures zooplankton accurately, determine why there are discrepancies between OPC and net results, and to determine what effect coincidence has on the OPC biomass measurements.

2. Methods

2.1. Field Measurements

[4] In order to obtain fine-scale spatial structure of zooplankton in southern Lake Michigan, a plankton survey system (PSS) was towed from a research vessel along various cross-isobath transects during the Episodic Events Great Lakes Experiment (EEGLE) in 1998–2000 to characterize the impact of the recurrent coastal sediment plume on plankton ecology and distribution (H. A. Vanderploeg *et al.*, Anatomy of the recurrent coastal plume in Lake Michigan and its impacts to light climate, nutrients and plankton, submitted to *Journal of Geophysical Research*, 2005, hereinafter referred to as Vanderploeg *et al.*, submitted manuscript, 2005). Transects were onshore-offshore in areas near Racine, Chicago, Gary, New Buffalo, St. Joseph, and Muskegon with depths along each transect going from 15 m to 80 m or 110 m depending on the transect (Vanderploeg *et al.*, submitted manuscript, 2005, Figure 1). The PSS [Ruberg *et al.*, 2001] consisted of a mini OPC

¹Great Lakes Environmental Research Laboratory, National Oceanic and Atmospheric Administration, Ann Arbor, Michigan, USA.

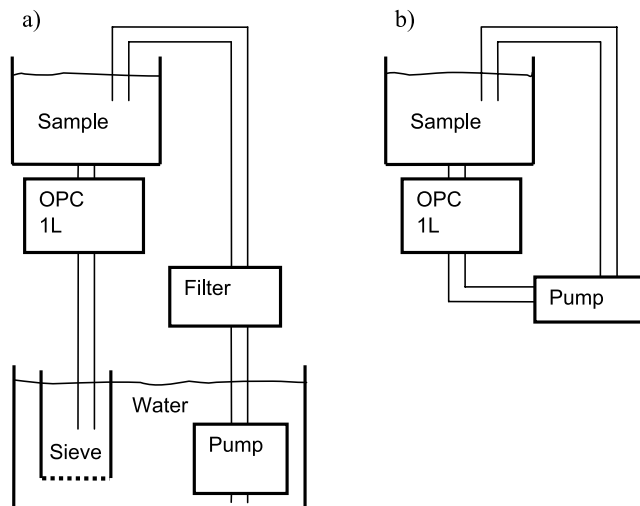

Figure 1. Schematic diagrams of the circulator system used in (a) low concentration and (b) high concentration laboratory experiments.

(Model 2T, Focal Technologies, Inc.), a mechanical flowmeter (General Oceanics), an Aquatracka III fluorometer (Chelsea Technology Group), an OS200 CTD (Ocean Sciences), and a photosynthetically active radiation (PAR) sensor mounted on a V-fin (Endeco/YSI). To obtain vertical as well as horizontal spatial structure, the PSS was continuously lowered and raised at $\sim 0.25 \text{ m s}^{-1}$ in a sinusoidal path between 1 and 2 m beneath the lake surface and 1 and 2 m above the bottom with the OPC logging data every 0.5 s as the boat moved at $\sim 2.5 \text{ m s}^{-1}$ along the transect.

[5] The OPC-2T operates in the same manner as the OPC-1T, which has been described by Herman [1988, 1992]; only the sampling tunnel is 10 cm wide instead of 25 cm [Focal Technologies, Inc., 1996]. Particles between 0.25- and 14-mm equivalent spherical diameter (ESD) are detected and measured as they go through the OPC. Each particle generates a signal proportional to the area of shadow cast as it passes a light beam and the OPC software converts the digital output to ESD, at least for spherical particles. For nonspherical particles such as zooplankton, the generated ESD is actually equal to an equivalent circular diameter (ECD) based on the area of a zooplankton's silhouette and is not necessarily equal to the zooplankton's true ESD [see also Beaulieu *et al.*, 1999]. Biomass (wet, based on volume assuming a density of 1.0 g cm^{-3}) calculated by the standard OPC software may be an underestimate or overestimate of the true biomass depending on the orientation of the particle as it passes the detector.

[6] For comparison to plankton net biomass, wet biomass computed by the standard OPC software was converted to dry biomass assuming dry biomass equal to 7% of wet

biomass [Malley *et al.*, 1989]. OPC estimates of zooplankton counts and biomass were converted to concentrations (m^{-3}) using the OPC time stamp and flowmeter data. Zooplankton abundance in three size bins (0.25–0.5 mm, 0.5–1.0 mm, 1.0–4.0 mm) from “chart files” generated by the OPC software was also used in comparisons with net data.

[7] To compensate for varying light transmitting properties of the surrounding water, the OPC measures light attenuation (analogous to beam attenuation of a transmissometer) to maintain constant light intensity across the sample tunnel [Herman, 1988]. Total suspended matter (TSM) can be derived from light attenuation after calibrating it to actual TSM measurements (Vanderploeg *et al.*, submitted manuscript, 2005). During the EEGLE cruise of March 1998, light attenuation was very high ($\text{TSM} > 30 \text{ mg L}^{-1}$) in the recurrent sediment plume and the OPC was unable to detect any zooplankton because light intensity dropped below the threshold necessary to detect zooplankton. Subsequently, the OPC laser diodes were strengthened 9.3 times so that the laser would be able to penetrate similar plumes and the OPC could detect zooplankton.

[8] Zooplankton samples were collected by towing a 50-cm-diameter, 2.5-m-long, 153- μm mesh plankton net vertically through the water column from bottom to surface at the start, middle, and end of all PSS transects. At each collection station, net sample comparisons were made with OPC data from the nearest surface to bottom undulation of the PSS, and OPC and net samples were usually within 1–4 hours of each other. The net was equipped with an internal TSK flowmeter (Model 005WA200, KAHL Scientific Instrument Corporation) so that the volume sampled could be determined. A 64- μm mesh, 30-cm diameter, 2.5-m-long plankton net was also used to get an estimate of small zooplankton (e.g., nauplii) that were not retained by the 153- μm net. The samples were preserved in a 4% sugar-formalin solution [Haney and Hall, 1973] for taxonomic identification. At least 600 individuals were identified in subsamples taken with a Stemple pipette, and counts were converted to individuals per cubic meter using information on volume counted and volume of water column sampled. Zooplankton lengths were measured under a microscope with a video camera using Image-Pro Plus (Media Cybernetics) imaging software, and dry biomass was calculated using published length-weight regressions [Culver *et al.*, 1985; Malley *et al.*, 1989].

[9] At each transect station, water samples were taken for analysis in the laboratory. Total suspended matter (TSM) was obtained by filtering 100 to 2000 mL of lake water through Whatman GF/C 47-mm filters and determining the mass after drying for 48 h at 60°C . Chlorophyll *a* was determined by filtering 50 to 200 mL of water through Whatman GF/F filters, extracting chlorophyll from the filters in N, N-dimethylformamide [Speziale *et al.*, 1984], and quantifying it with a Turner Designs 10-AU-005-CE

Table 1. Comparison of Copepod Nauplii and Total Zooplankton Caught in 64- and 153- μm Plankton Nets From Offshore Lake Michigan (M110) on 19 March 1998

	Nauplius Mean Length, mm	Nauplius Mean Dry Biomass, μg	Nauplius Count, m^{-3}	Nauplius Total Dry Biomass, mg m^{-3}	Total Zooplankton Count, m^{-3}	Total Zooplankton Biomass, mg m^{-3}
64- μm net	0.165	0.142	8683	1.23	10452	9.28
153- μm net	0.325	0.447	1236	0.55	3815	10.7

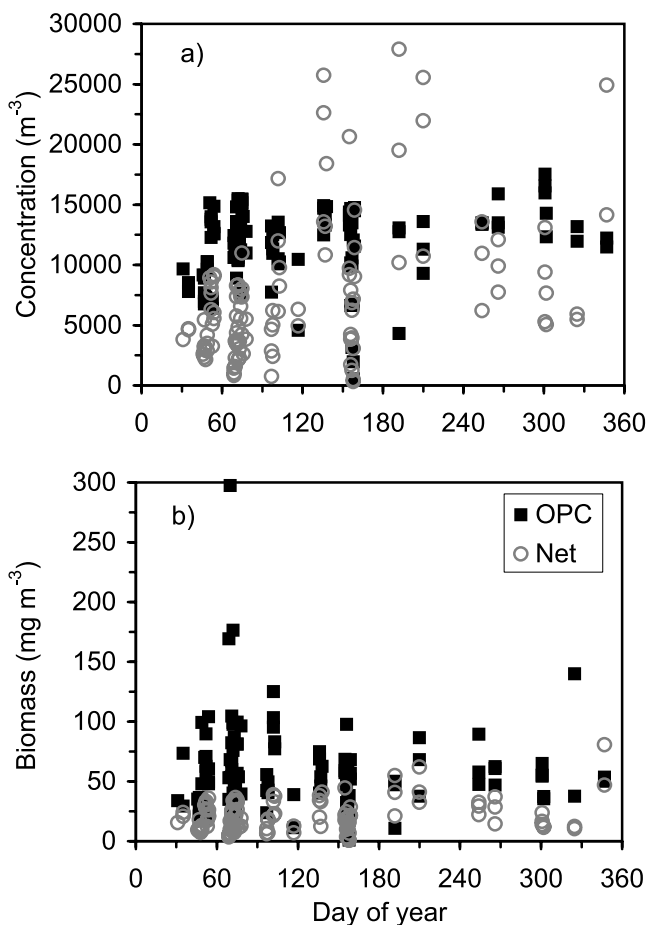

Figure 2. Temporal plots of (a) zooplankton density and (b) dry biomass from OPC and plankton net samples taken from southern Lake Michigan in 1998–2000.

fluorometer using the acid correction method [Parsons *et al.*, 1984].

2.2. Laboratory Experiments

[10] The laboratory OPC (Model 1L, Focal Technologies Inc.) was used to test OPC performance under controlled conditions. The basic operating principle of the laboratory unit is the same as for the field unit (Model 2T), but the sensing zone is 2 cm wide (1.6 ml) instead of the 10 cm wide (8 ml) for the field OPC [Focal Technologies, Inc., 1996]. This difference does not matter for determining counts and sizes of particles at low concentrations but does matter for determining the effect of coincidence as explained later when describing those experiments.

[11] To test OPC accuracy on ellipsoid or rod shapes at low concentrations, we modified the design of a circulator system (Figure 1a) suggested by Focal Technologies [MacKay, 1996]. Water was pumped from a large reservoir (~50 L) through a cartridge filter, to remove unwanted particles, up to a smaller reservoir where the test sample was added. From there the water and sample were gravity fed through the lab OPC at $1.0\text{--}1.5\text{ m s}^{-1}$ and into a collection chamber below, a drop of about 106 cm. Experimental samples consisted of 500- μm and 1-mm polymer microspheres (Duke Scientific Corp.), black and translucent nylon

rods, or various groups of live zooplankton. Rods were made by cutting bundles of black or “clear” nylon monofilaments to 1 mm lengths using a microtome. Mean actual dimensions (length and diameter) of the rods were 959 μm by 381 μm for black and 1124 μm by 306 μm for translucent. The microspheres were used to verify OPC accuracy, and the black and clear rods were surrogates for zooplankton to test the effect of elongated shape and translucency. To determine how the OPC measures zooplankton, aliquots of live cyclopid copepods (mixture of copepodites and adults), calanoid copepods (mostly *Diaptomus* spp.), and *Limnocalanus macrurus* were tested. The test subjects were added at low concentrations so that coincidence would not be a factor and were recovered using a 100- μm sieve after passing once through the OPC. They were counted and measured under a microscope using the video digitizing system described above. Actual ESD and volumes were calculated from length and width measurements to compare with OPC results. To simulate results of the OPC detecting the maximal silhouette of targets passing through the sensing zone, the ECD of maximal silhouette area was calculated and this was used as the ESD to calculate volume. For tests with zooplankton, actual biomass was calculated from

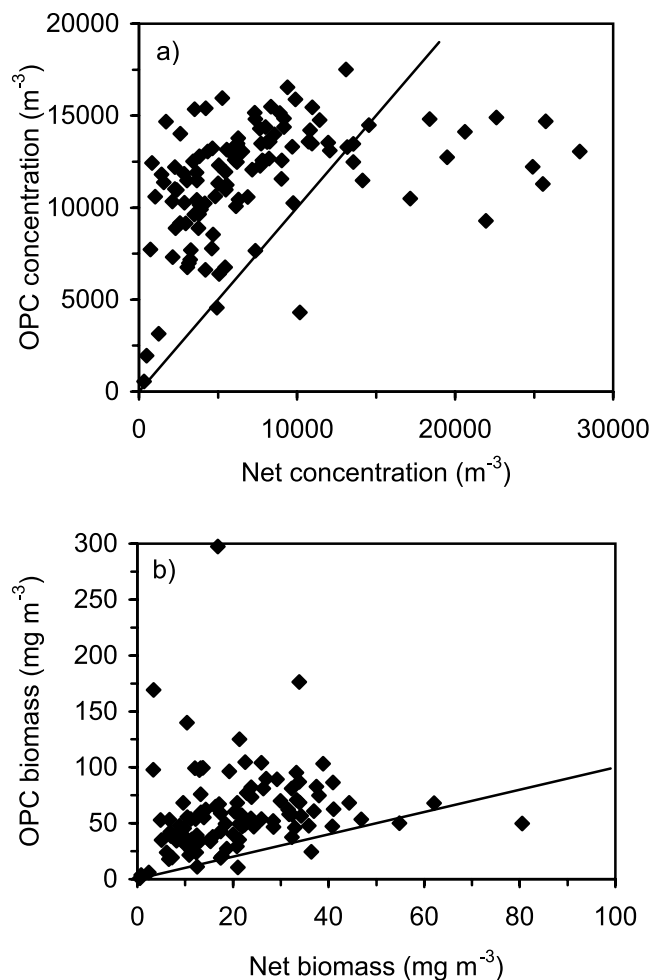

Figure 3. (a) OPC versus net density and (b) OPC versus net dry biomass for 1998–2000 surveys in Lake Michigan. The 1:1 line is shown.

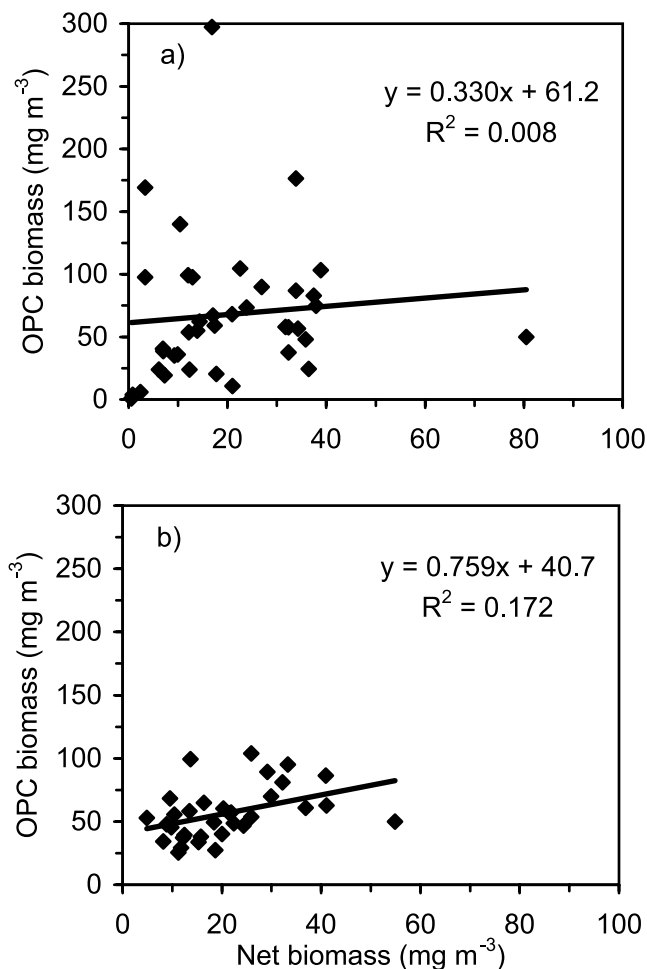

Figure 4. OPC versus net dry biomass in southern Lake Michigan: (a) inshore (10–15 m deep) stations, regression not significant ($p > 0.05$); (b) offshore (80–150 m deep) stations, regression significant ($p < 0.05$).

published length-weight relationships [Culver *et al.*, 1985; Malley *et al.*, 1989] and actual ESD was calculated from that biomass assuming dry biomass equal to 7% of wet biomass and a volume density of 1.0 g cm^{-3} . Maximal ECD was calculated assuming the shape of an ellipse and using measured lengths and widths or published length-width relationships [Malley *et al.*, 1989].

[12] To test the effect of coincidence, the OPC circulator system (Figure 1b) was modified to include only one reservoir (6 L) because the total volume of water in the system had to be much smaller to obtain high concentrations of the limited supply of test particles. The flow rate was approximately 2.3 m s^{-1} and was completely pump driven. The size of the microspheres was limited by what could be circulated through the centrifugal pump without being damaged. A set amount of 500-m polymer microspheres was added to the reservoir and circulated through the system many times, usually for 3 to 4 min (to get a good count at low concentrations). This was repeated for different concentrations to simulate what may be encountered in the field, from very low when coincidence is negligible to very high when coincidence is likely a problem. Concentration and volume of the spheres in circulation was determined,

and this was compared to the concentration and volume measured by the lab OPC. Since the sensing zone of the lab OPC is 1.6 ml instead of the 8 ml for the field OPC [Focal Technologies, Inc., 1996], the lab OPC detects one fifth of the particles that the field OPC does at a particular particle concentration. The effect of coincidence for the field OPC would be the same as the lab OPC at one fifth of the particle concentration for the lab OPC. Therefore, to determine the effect of coincidence at an equivalent field OPC concentration, sphere concentrations used in the experiments were divided by 5.

3. Results

3.1. Field

[13] Results from Lake Michigan field studies in 1998–2000 indicated mostly poor agreement between the OPC-2T and the 153- μm mesh plankton net. Since the 153- μm mesh net was more efficient collecting zooplankton biomass than the 64- μm mesh net (Table 1), the 153- μm mesh net data were used in all comparisons with the OPC. OPC counts ranged from 0.5 to 17.5 L^{-1} and biomass 0.9 to $297 \mu\text{g L}^{-1}$, while corresponding plankton net counts range from 0.3 to 27.9 L^{-1} and biomass 0.5 to $80.5 \mu\text{g L}^{-1}$ (Figure 2). OPC

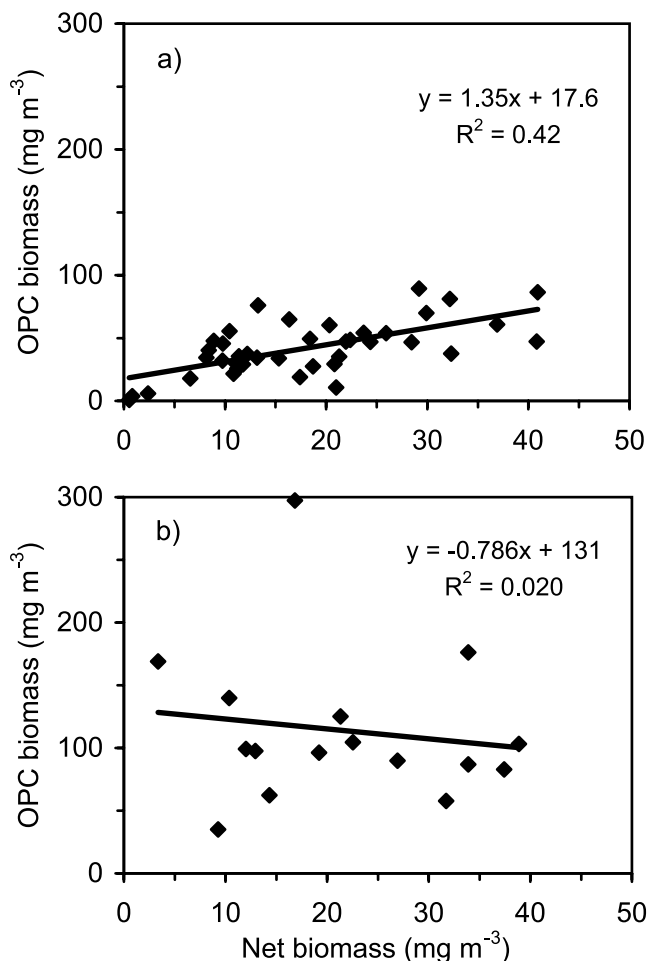

Figure 5. OPC versus net dry biomass for (a) low TSM ($<1 \text{ mg L}^{-1}$), regression significant ($p < 0.05$); and (b) high TSM ($>3 \text{ mg L}^{-1}$), regression not significant ($p > 0.05$).

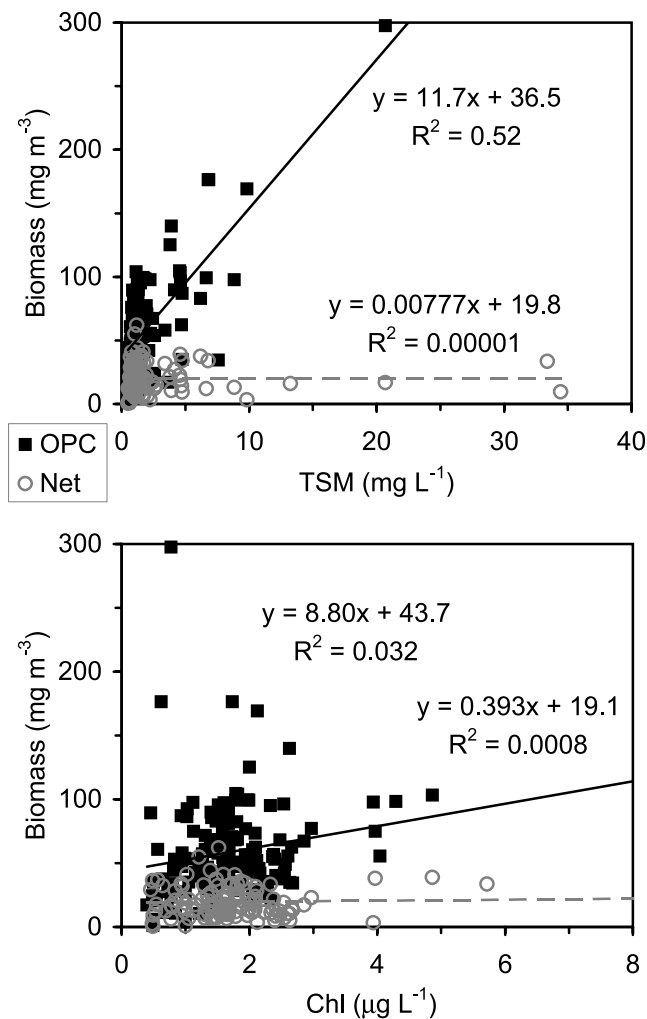

Figure 6. Effects of (a) total suspended matter (TSM) and (b) chlorophyll on OPC (solid squares) and plankton net (open circles) dry biomass. Only the regression for OPC versus TSM is significant ($p < 0.05$).

zooplankton abundances (number L^{-1}) were higher in winter and spring than those from the net and sometimes lower in the summer. Plankton net abundances were more variable than OPC abundances. OPC biomass was generally greater and more variable than net biomass and overall they were not well correlated (Figure 3). There was significant correlation ($p < 0.05$) between OPC and net biomass offshore (depth >60 m), but the relationship was weak (Figure 4). OPC and net biomass showed no correlation inshore (depth <20 m).

[14] The amount of suspended particulate matter (TSM) and sometimes phytoplankton affected OPC results, increasing biomass totals at high TSM levels. OPC biomass was positively correlated ($p < 0.05$) with net biomass at TSM <1 $mg L^{-1}$ (Figure 5a), but they were not correlated at TSM >3 $mg L^{-1}$ (Figure 5b). At higher TSM levels (7–21 $mg L^{-1}$), biomass measured by the OPC was 5 to 50 times that of net tows. After periods of high turbulence, TSM of up to 34 $mg L^{-1}$ was measured in nearshore zones. OPC biomass was positively correlated with TSM, but there was no correlation between net results and TSM

(Figure 6). Phytoplankton may add to OPC biomass at times. There was a weak positive correlation between OPC biomass and ambient chlorophyll concentration, but there was no correlation between net biomass and chlorophyll concentration (Figure 6). To try to understand what was causing the large discrepancies between the OPC and net samples, a net tow sample from a time of high TSM (March 1999 at a 15-m station off of Chicago) was examined, and it displayed a lot of nonzooplankton debris (Figure 7). The corresponding OPC sampling apparently detected this debris or other large particles because $\sim 25\%$ of the OPC counts, equal to $\sim 70\%$ of OPC biomass, showed up in the largest size bin (1.00–4.00 mm), and there were few zooplankters of that size in the net sample.

3.2. Laboratory

[15] Overall, in laboratory experiments at low particle concentrations, OPC measurements of spheres, rods, and zooplankton showed good agreement with microscope measurements (Figure 8). Results of some representative individual experiments are given to illustrate how size spectrum can change depending on the translucency or orientation of a particle. Spheres (1-mm diameter) were counted accurately by the OPC (164, same as microscope count), but were sized a little smaller than their true measurement (total volume for count of 69.8 mm^3 versus 85.3 mm^3 for the microscope) likely due to being somewhat translucent (Figure 9). The OPC measurements of black rods (count = 161, total vol. = 16.3 mm^3) compared favorably with calculated ESD of actual rod measurements (count = 157, total vol. = 17.2 mm^3) determined with a

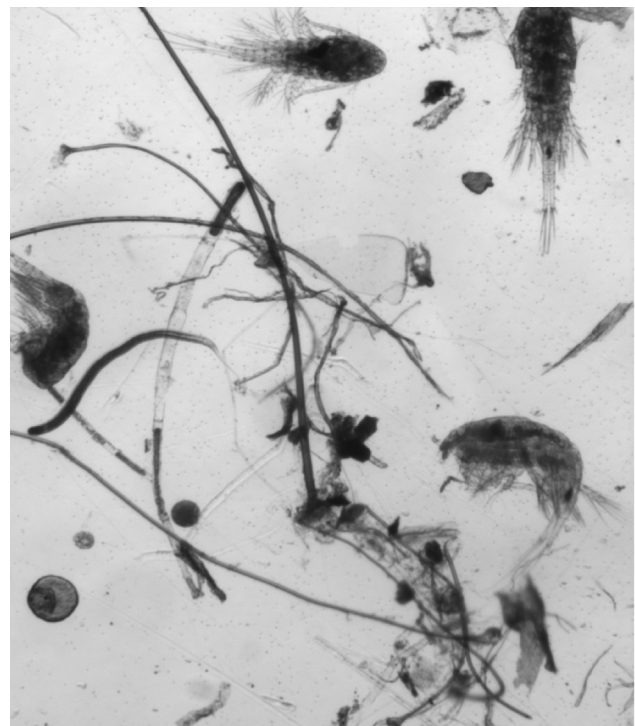

Figure 7. Photograph of a sample from a 153- μm mesh zooplankton net collected at a 15-m-deep station in Lake Michigan off of Chicago in March 1999. Note the large nonzooplankton debris.

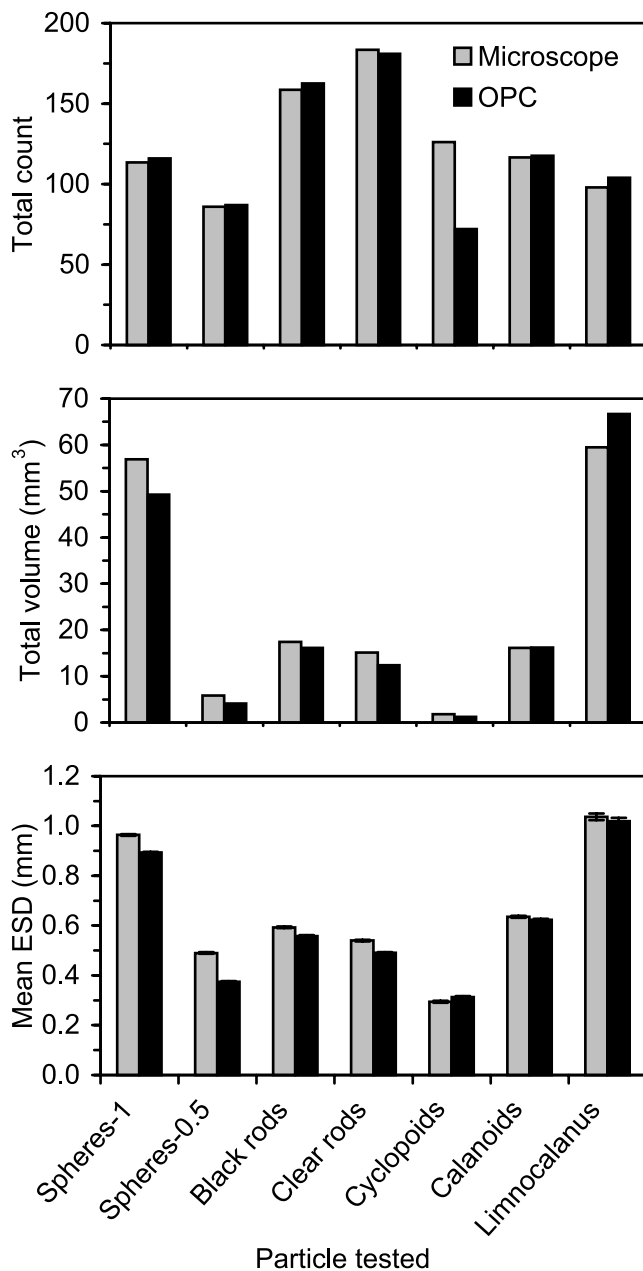

Figure 8. Summary of results for total count, total volume (mm³), and mean ESD \pm SE (mm) of all laboratory OPC experiments. The bars represent means of duplicate tests for each of the particle groups except for 500- μ m spheres and *Limnocalanus* (single tests) with the microscope results in gray and the OPC results in black.

microscope, but the OPC size spectrum was broader (Figure 10a). When volume was calculated based on maximum ECD (i.e., the ECD based on the maximum silhouette area always being detected by the OPC), the size spectrum shifted to the right of the OPC result (total vol. = 26.3 mm³), indicating that the orientation of the target was random rather than its long axis always being aligned with the flow in the tube as would be required for maximum ECD. Translucent rods were sized slightly smaller by the OPC (total vol. = 11.9 mm³ versus 14.8 mm³ for microscope) as might be expected (Figure 10b). As with the

rods, it appeared that live copepods were randomly oriented as they passed through the OPC because the OPC biomass spectrum was closer to the calculated actual biomass based on ESD than that based on maximum ECD. There were 126 calanoids with a total actual biomass of 16.6 mg that were measured by the OPC as 127 animals and a total biomass of 15.8 mg compared with a total biomass based on maximum ECD of 31.8 mg (Figure 11a). Results were similar for cyclopoid copepods (Figure 11b) with a total actual biomass of 1.48 mg, a total of 1.21 mg for the OPC, and a total of 3.95 mg based on maximum ECD. However, only 72 of the 128 cyclopooids were counted by the OPC. Evidently, the OPC was significantly off on the count because many of the cyclopooids had an ESD below the OPC detection threshold of 250 μ m, and the translucency of the animals may have caused a few more to fall below detection. Since the animals not detected were small copepodites, biomass was not impacted much.

[16] The coincidence experiments showed that as the concentration of spheres in the OPC circulation system increased, the size spectrum broadened, adding a shoulder to the right (Figure 12). The peak in volume essentially shifted to the right with increasing particle concentration indicating an increase in the detected particle size. As expected, the OPC counts did not increase as fast as actual counts indicating that coincidence increased with increasing concentration. It appeared that the OPC reached a saturation limit at about 29 L⁻¹. The ratio of OPC mass to actual mass was actually <1 at concentrations of 70 and 145 L⁻¹ (Figure 13b). Although a decrease in mass detected by the OPC would be expected at high levels of coincidence due to overlapping of particles, it was surprising since 70 L⁻¹ is still <1 sphere in the OPC-2T detection beam at a time based on even distribution of spheres. The spheres were not evenly distributed in the circulation system, but they were not grossly clumped together either; the count rate over the length of an experiment was fairly constant with small fluctuations,

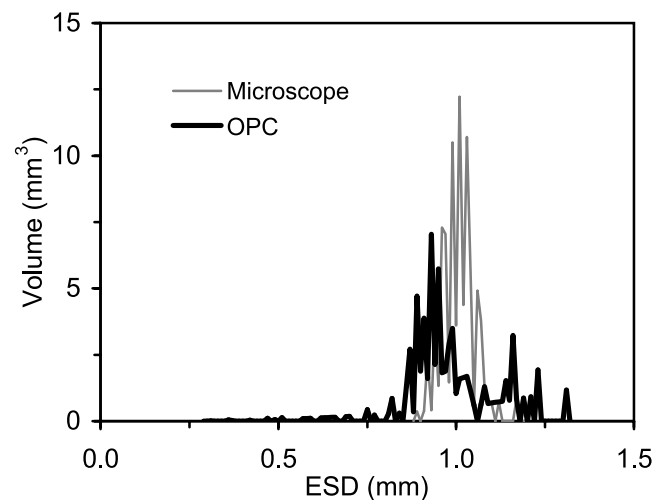

Figure 9. Size spectrum of 1-mm sphere volume as measured by the OPC (black line) and as calculated from dimensions measured using image analysis software (gray line).

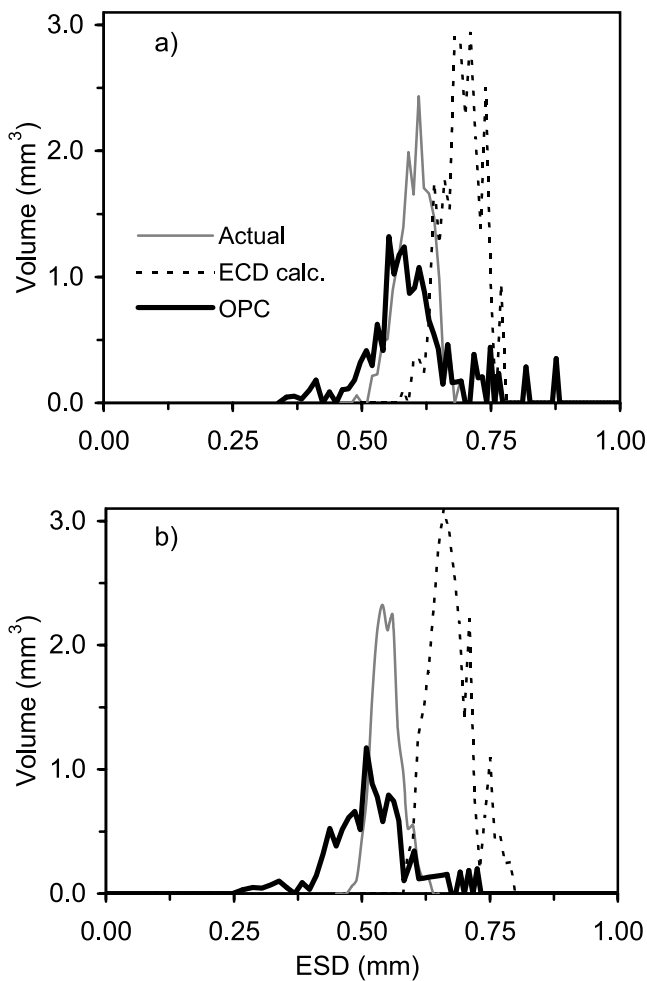

Figure 10. Size spectrum of volume for (a) black and (b) translucent rods. Volumes were determined by the OPC (black line), calculated from microscope measurements of length and radius (actual, gray line), and calculated using the ECD of maximum possible silhouette area as the ESD (ECD calculated, dashed line).

suggesting a random distribution. The saturation limit was likely determined mainly by electronic limitations of the OPC circuitry [see *Sprules et al.*, 1998].

4. Discussion

[17] Results from our field surveys in Lake Michigan showed that the OPC often overestimated zooplankton biomass compared to a 153- μm mesh plankton net, and overestimated or underestimated zooplankton abundance depending on lake conditions or time of year. Similar results have been observed in other studies [*Halliday et al.*, 2001; *Heath et al.*, 1999; *Sprules et al.*, 1998; *Wieland et al.*, 1997; *Zhang et al.*, 2000]. However, our laboratory experiments with polymer microspheres, nylon rods, or live zooplankton in an OPC circulator system confirmed that the OPC does fairly well estimating counts and biomass at low particle concentrations similar to zooplankton concentrations typically found in Lake Michigan. Since many zooplankters are translucent or clear depending on the age of the animal, they may even be undersized by the OPC.

[18] When comparing OPC and net data, the mesh size of the net can be an important factor depending on the size structure of the zooplankton community. We believe our choice of net was appropriate for comparing with OPC data. Net counts may be lower than OPC counts due to extrusion; some nauplii and small copepodites that slip through the 153- μm net may be detected by the OPC. In our experience, the 153- μm net only captures 10–15% of nauplii at times and a substantial portion of copepodites may be extruded. However, most of those extruded nauplii and copepodites would be too small to be detected by the OPC. We have also used a 64- μm mesh net, which does much better than the 153- μm net collecting nauplii, but does not do as well for the remainder of the zooplankton (Table 1).

[19] Assuming for the sake of argument (and not necessarily true) that plankton net tows give good estimates of number and biomass, three factors potentially affecting OPC results have been cited to explain the disparity between OPC and net data. The first concerns the orientation of elongated ellipsoidal-shaped zooplankters. The OPC

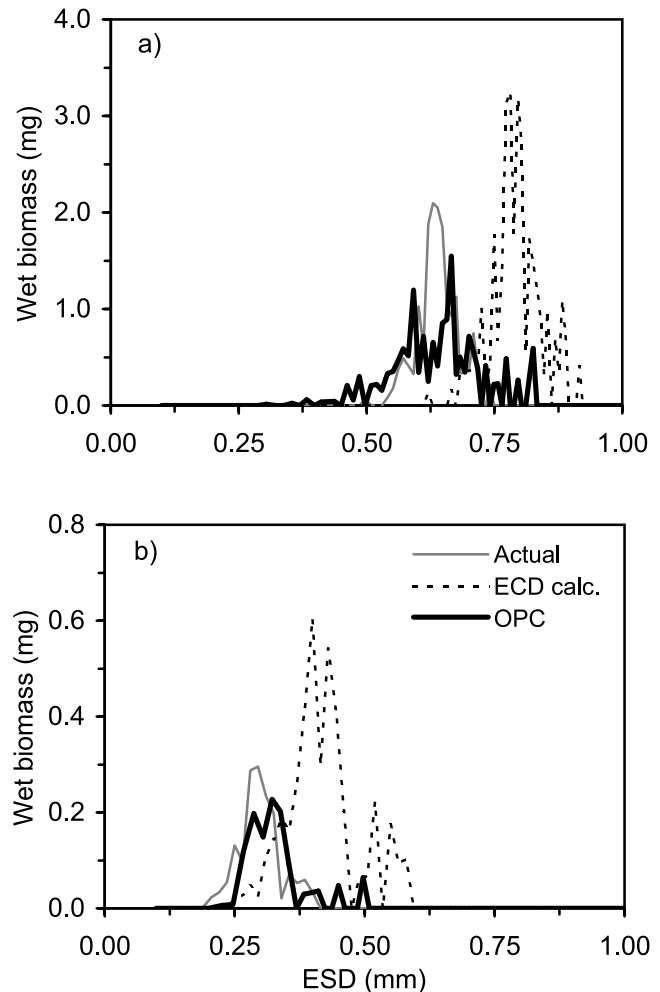

Figure 11. Size spectrum of live copepod volume as determined by the OPC (black line), as calculated from length-weight relationships using microscope measurements (actual, gray line), and as calculated using the ECD of the maximum possible silhouette area as the ESD (ECD calculated, dashed line) for (a) calanoids and (b) cyclopoids.

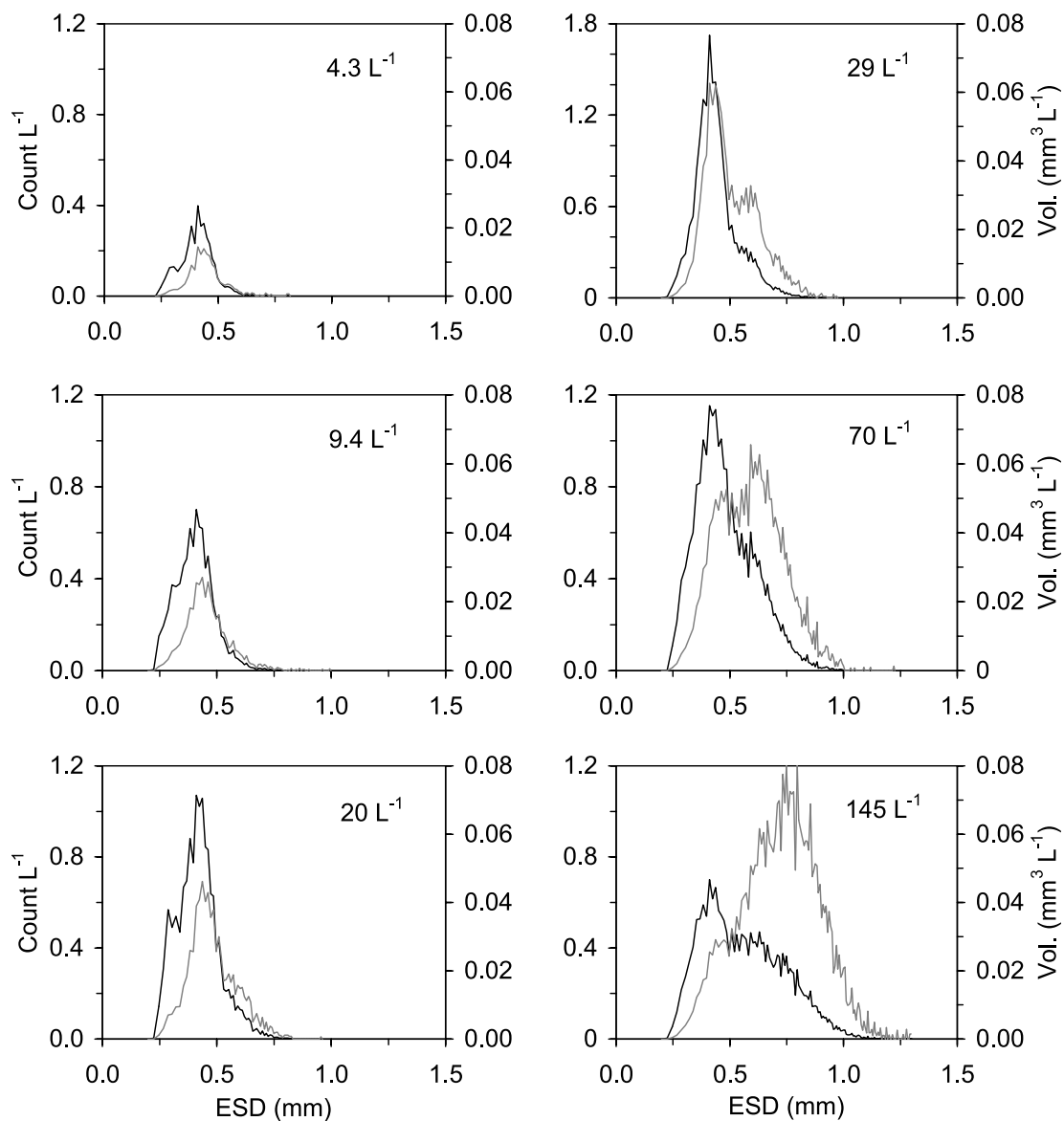

Figure 12. Size spectrum of 500- μm sphere count L^{-1} (black line) and volume L^{-1} (gray line) as measured by the OPC-1L over increasing concentrations. The concentration of the sphere suspension, converted to the OPC-2T equivalent, is shown in each panel. Note that the scale is different for count in the 29 L^{-1} panel.

will overestimate biomass if the maximum area of an elongated target is detected. The second factor is coincidence, which occurs when more than one target is in the sensing zone at the same time. This can result in overestimation of biomass because volume (and ESD) calculated from projected area of two targets in the sensing zone is greater than the sum of the volume of two targets and an underestimation of abundance because only one sphere is counted instead of two [Sprules *et al.*, 1992, 1998; Woodd-Walker *et al.*, 2000]. Third, while not emphasized in freshwater literature, particles other than zooplankton can affect zooplankton abundance and biomass [Heath *et al.*, 1999; Herman, 1992; Zhang *et al.*, 2000].

[20] Most of the attention in the literature has focused on shape factor and coincidence. Other investigators have indicated that high zooplankton densities can result in an

undercounting of zooplankton and an overestimation of biomass by the OPC [Herman, 1988; Sprules *et al.*, 1992, 1998]. Although the effect should be small at the low zooplankton densities found in Lake Michigan, our laboratory experiments confirmed that coincidence counting can lead to underestimates of abundance (Figure 13a). The OPC apparently reached a saturation limit of $\sim 25 \text{ L}^{-1}$ which negated any overestimation of biomass at high concentrations (Figures 13a and 13b). In Lake Michigan, the OPC-2T appeared to reach a saturation limit at $\sim 18 \text{ L}^{-1}$ (Figures 2 and 3) and $\sim 100 \text{ s}^{-1}$, which was only about half of the expected maximum theoretical concentration and count rate for our typical flow rate of 2.5 m s^{-1} [Woodd-Walker *et al.*, 2000]. Sprules *et al.* [1998] showed that coincidence of two identical spheres in the sensing zone results in a loss of count and a 44% increase in biovolume. Since very small

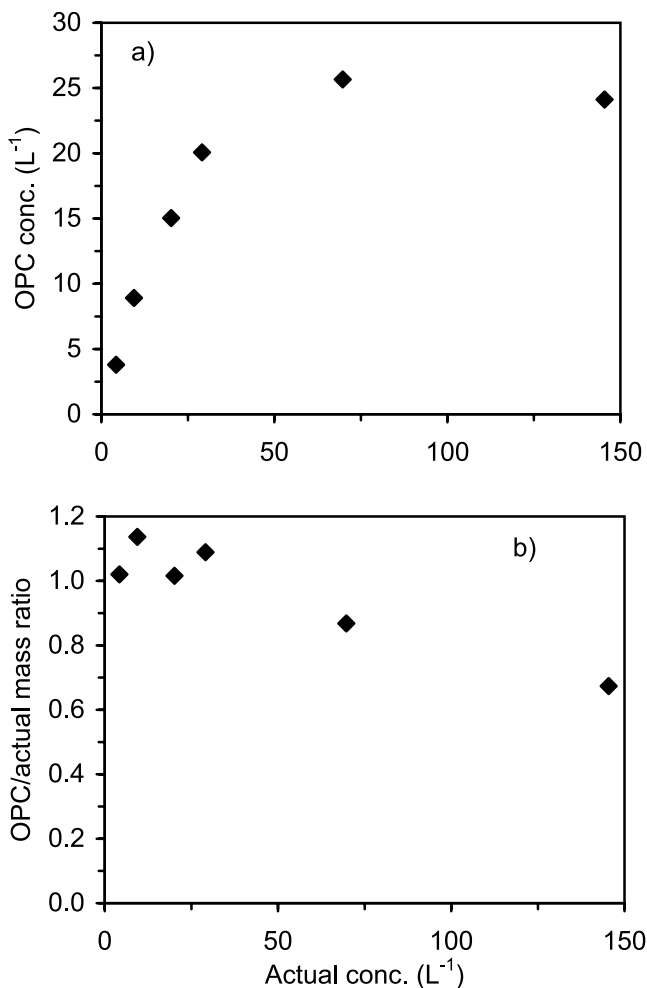

Figure 13. (a) OPC versus actual concentration of 500- μm spheres and (b) ratio of OPC mass to actual mass as a function of concentration.

zooplankton are responsible for most of the counts but not biomass, the OPC should do a better job on biomass than count, as noted by *Sprules et al.* [1998]. To account for lack of agreement between net tow data and OPC biomass in Lake Erie, *Sprules et al.* [1998] determined a shape correction factor that would compensate for both shape and coincidence artifacts, and further suggested that this shape factor could be applied to freshwater zooplankton in general to get correct estimates of biomass.

[21] From our laboratory study, it appears that the shape factor is not a problem, and targets pass through the OPC in random orientation resulting in a smaller mean cross-sectional area, and thus a mean OPC ESD closer to the true ESD, than if the maximum area of a target was always seen by the OPC. Flow dynamics in lakes would be different than in the lab, but the orientation of zooplankters detected by the OPC may be random in the field as well [*Herman*, 1988; *Wieland et al.*, 1997]. Because of this, the OPC is good at estimating zooplankton biomass even though it may not always estimate abundance well. Therefore we do not advocate the general use of a shape factor correction for all environments. In habitats or times that are dominated by very small zooplankton at or below the OPC detection limit

such as small cyclopoids, copepodites, and nauplii, the OPC will significantly underestimate zooplankton abundance and may underestimate biomass as well. Another consequence of random orientation is that the OPC size spectrum for any one species is broader than actual (Figures 10 and 11), and the spectrum broadens with increasing length-to-width ratios. This makes it very difficult in diverse communities to separate out different species that already overlap in size [*Herman*, 1992; *Wieland et al.*, 1997]. In the Great Lakes, since it is difficult to distinguish distinct OPC size signatures for individual species, the OPC should be used in conjunction with net collections to get accurate taxonomic data.

[22] The most likely explanation for poor agreement between OPC and net tow data was nonzooplankton particles, consisting of fine sediments and large particles such as sediment-phytoplankton aggregates, and benthic plant and animal debris, that were associated with TSM, itself an indicator of turbulence and resuspension. OPC biomass and net biomass was poorest during periods of high TSM, with the highest OPC value more than 10 times larger than that of the net (Figures 5 and 6). OPC biomass even displayed a positive correlation with TSM, which was not evident with net biomass (Figure 6a), including many counts in the 1.00–4.00 mm size bin in which few zooplankton would be found. As evidenced by the photograph of a net collection (Figure 7), some of the larger material was resuspended organic debris. It is also likely there were clay-phytoplankton aggregates associated with resuspension events that would have been too fragile to remain intact in preserved collections from net tows (*Vanderploeg et al.*, submitted manuscript, 2005). Not only can particle aggregates be counted if large enough (>250 μm ECD) to be detected by the OPC, as demonstrated in this study and others [*Halliday et al.*, 2001; *Heath et al.*, 1999; *Herman*, 1992; *Huntley et al.*, 1995], but even particles that individually are too small (<250 μm ECD) to be detected by the OPC may be detected due to coincidence if they are abundant enough [*Halliday et al.*, 2001; *Herman*, 1992; *Zhang et al.*, 2000]. According to our laboratory tests with clay suspensions (*J. R. Liebig*, unpublished data, 2002) and experiments with detritus by *Zhang et al.* [2000], background particles <100 μm can contribute to OPC (>250 μm) counts and biomass. Small particles can increase coincidence and OPC zooplankton abundance, but have a lesser effect on biomass [*Halliday et al.*, 2001; *Sprules et al.*, 1998; *Zhang et al.*, 2000].

[23] In summary, we conclude that the OPC accurately counts and sizes most zooplankton at low zooplankton concentrations when other suspended particles are also low such as offshore areas or inshore areas away from rivers under calm conditions. A common problem in Lake Michigan was overestimate of zooplankton biomass by the OPC relative to net tows. Such overestimates have been attributed to the orientation of zooplankton assuming their maximal silhouette area is detected by the OPC, coincidence, and presence of nonzooplankton particles. It appears from our research and that of others [*Herman*, 1988; *Wieland et al.*, 1997] that zooplankton pass through the OPC in random orientation, which compensates for elongated shapes and results in reasonable estimates of biomass. Shape factor corrections for biomass need not be

applied. The major cause of OPC biomass overestimation was the high abundance of particles other than zooplankton, particularly in shallow nearshore zones. In our study, worst agreement between the OPC and plankton net was seen during periods of high suspended matter (TSM) associated with resuspended bottom sediments found in the storm-generated recurrent coastal sediment plume (Vanderploeg et al., submitted manuscript, 2005). The TSM consisted not only of fine sediments but large particles such as sediment-phytoplankton aggregates, and detrital benthic plant and animal debris. Best agreement was found under low TSM conditions associated with offshore waters during the stratified period. Our results imply that caution must be exercised in using the OPC in turbid conditions and in nearshore areas impacted by tributary loading. Coincidence is not much of a factor for the OPC-2T at zooplankton densities common in Lake Michigan, but may be a problem in lakes with higher densities. Because of inherent differences in sampling between plankton nets and the OPC, field comparisons should be made with consideration of ambient conditions, and "calibrating" the OPC to net results should be done within defined spatial, temporal, and physical parameters. The OPC is a good tool for gathering spatial data consisting of zooplankton abundance, biomass, and size frequency distribution, but should be used in conjunction with some plankton net samples to provide species information.

[24] **Acknowledgments.** We thank M. Bundy for use of the OPC-1L, T. Miller for assistance in constructing the OPC circulator system, and S. Skripnik for producing the microrods used in the experiments. We also thank two anonymous reviewers for their helpful comments and suggestions that improved the clarity of the manuscript. This is GLERL contribution 1370.

References

- Beaulieu, S. E., M. M. Mullin, V. T. Tang, S. M. Pyne, A. L. King, and B. S. Twining (1999), Using an optical plankton counter to determine the size distributions of preserved zooplankton samples, *J. Plankton Res.*, *21*, 1939–1956.
- Culver, D. A., M. M. Boucherle, D. J. Bean, and J. W. Fletcher (1985), Biomass of freshwater crustacean zooplankton from length weight regressions, *Can. J. Fish. Aquat. Sci.*, *42*, 1380–1390.
- Focal Technologies, Inc. (1996), Optical plankton counter user's guide, 23 pp., Dartmouth, Nova Scotia, Canada.
- Grant, S., P. Ward, E. Murphy, D. Bone, and S. Abbott (2000), Field comparison of an LHPR net sampling system and an optical plankton counter (OPC) in the southern ocean, *J. Plankton Res.*, *22*, 619–638.
- Halliday, N. C., S. H. Coombs, and C. Smith (2001), A comparison of LHPR and OPC data from vertical distribution sampling of zooplankton in a Norwegian fjord, *Sarsia*, *86*, 87–99.
- Haney, J. F., and D. J. Hall (1973), Sugar-coated Daphnia: A preservation technique for cladocera, *Limnol. Oceanogr.*, *18*, 331–333.
- Heath, M. R., J. Dunn, J. G. Fraser, S. J. Hay, and H. Madden (1999), Field calibration of the optical plankton counter with respect to *Calanus finmarchicus*, *Fish. Oceanogr.*, *8*, Suppl. 1, 13–24.
- Herman, A. W. (1988), Simultaneous measurements of zooplankton and light attenuation with a new optical plankton counter, *Cont. Shelf Res.*, *8*, 205–221.
- Herman, A. W. (1992), Design and calibration of a new optical plankton counter capable of sizing small zooplankton, *Deep Sea Res.*, *39*, 395–415.
- Herman, A. W., N. A. Cochrane, and D. D. Sameoto (1993), Detection and abundance estimation of euphausiids using an optical plankton counter, *Mar. Ecol. Prog. Ser.*, *94*, 165–173.
- Huntley, M. E., M. Zhou, and W. Nordhausen (1995), Mesoscale distribution of zooplankton in the California current in late spring, observed by optical plankton counter, *J. Mar. Res.*, *53*, 647–674.
- MacKay, I. (1996), Using the OPC-1L laboratory unit, *Appl. Note 4*, 6 pp., Focal Technol., Inc., Dartmouth, Nova Scotia, Canada.
- Malley, D. F., S. G. Lawrence, M. A. MacIver, and W. J. Findlay (1989), Range of variation in estimates of dry weight for planktonic Crustacea and Rotifera from temperate North American lakes, *Can. Tech. Rep. Fish. Aquat.*, 1666.
- Parsons, T. R., Y. Maita, and C. M. Lalli (1984), *A Manual of Chemical and Biological Methods for Seawater Analysis*, 173 pp., Elsevier, New York.
- Ruberg, S. A., H. A. Vanderploeg, J. F. Cavalletto, G. A. Lang, J. R. Liebig, T. C. Miller, and M. Agy (2001), Plankton survey system, in *Proceedings of the Oceans 2001 MTS/IEEE Conference, Honolulu, HI, November 5–8, 2001*, pp. 1899–1903, Mar. Technol. Soc., Columbia, Md.
- Speziale, B. J., S. P. Schreiner, P. A. Giammatteo, and J. E. Schindler (1984), Comparison of n,n-dimethylformamide, dimethylsulfoxide, and acetone for extraction of phytoplankton chlorophyll, *Can. J. Fish. Aquat. Sci.*, *41*, 1519–1522.
- Sprules, W. G., B. Bergstrom, H. Cyr, B. R. Hargreaves, S. S. Kilham, H. J. MacIsaac, K. Matshushita, R. S. Stemberger, and R. Williams (1992), Non-video optical instruments for studying zooplankton distribution and abundance, *Arch. Hydrobiol. Beih.*, *36*, 45–58.
- Sprules, W. G., E. H. Jin, A. W. Herman, and J. D. Stockwell (1998), Calibration of an optical plankton counter for use in fresh water, *Limnol. Oceanogr.*, *43*, 726–733.
- Wieland, K., D. Peterson, and D. Schnack (1997), Estimates of zooplankton abundance and size distribution with the optical plankton counter (OPC), *Arch. Fish. Mar. Res.*, *45*, 271–280.
- Woodd-Walker, R. S., C. P. Gallienne, and D. B. Robins (2000), A test model for optical plankton counter (OPC) coincidence and comparison of OPC-derived and conventional measures of plankton abundance, *J. Plankton Res.*, *22*, 473–483.
- Zhang, X., M. Roman, H. Adolf, C. Lascara, and R. Burgett (2000), Can an optical plankton counter produce reasonable estimates of zooplankton abundance and biovolume in water with high detritus?, *J. Plankton Res.*, *22*, 137–150.

J. R. Liebig, S. A. Ruberg, and H. A. Vanderploeg, Great Lakes Environmental Research Laboratory, NOAA, 2205 Commonwealth Blvd., Ann Arbor, MI 48105, USA. (jim.liebig@noaa.gov)