

Diesel Safety Component Certification Applications, 30 CFR 36



U.S. Department of Labor
Mine Safety and Health Administration
Approval and Certification Center

Program Circular
PC 4023-0
1985



This publication is one of a series that is intended to aid those interested in applying for an approval of their mining product from the Mine Safety and Health Administration's (MSHA's) Approval and Certification Center. The A&CC series of publications outlines the Approval and Certification Center's standard procedures for investigations, applications, and testing.

Additional single free copies of this booklet are available from the:

Approval and Certification Center, Technical Support
Mine Safety and Health Administration
U.S. Department of Labor
R.R.# 1, Box 251
Industrial Park Boulevard
Triadelphia, West Virginia 26059

Material contained in this booklet is in the public domain and may be reproduced without permission; source credit is requested, but not required.

Approval and Certification Center
Division of Mechanical Safety

Application Procedures for
Certification of Safety Component Systems
for Diesel Engines Under
Part 36, Title 30, Code of Federal Regulations

INTRODUCTION

Safety component systems provide protection against the fire and explosion hazards associated with the use of diesel engines in gassy mines. The Approval and Certification Center (A&CC) issues letters of certification for safety component systems which meet the requirements of Part 36, Title 30, Code of Federal Regulations (30 CFR 36). An individual, partnership, company, corporation, association, or other organization that designs, manufacturers, assembles, or controls the assembly of the equipment can seek a letter of certification. Applications for certification are accepted only if the system uses a diesel engine certified under Part 36. Applications for these certifications are subject to the technical requirements of Part 36 and the administrative requirements of Part 5. A copy of Title 30, Mineral Resources, CFR, which contains these Parts, can be purchased from:

Superintendent of Documents
U.S. Government Printing Office
Washington, D.C. 20402
Telephone (202)783-3238

Attached are current documents, publications, and Mine Safety & Health Administration (MSHA) Policy Memorandums relating to certification of safety component systems.

APPLICATION

Before submitting an application, the applicant should carefully review 30 CFR and the attached documents. Applications for certification are made by a formal letter of request. The letter shall include a six (6) digit company assigned application number. The applicant shall submit drawings and specifications of the safety component system and any other information which would aid MSHA in evaluation.

FEES FOR TESTING, EVALUATION, AND
APPROVAL OF MINING PRODUCT

Part 5 establishes the system under which MSHA charges a fee for service performed in connection with testing, evaluation, and approval of products manufactured for use in underground mines.

DRAWING AND SPECIFICATIONS

Include the following drawings and specifications with the application letter:

- I. A complete drawing list of those drawings and specifications which shows the details of the construction and design of the safety component system.
- II. A general arrangement drawing showing the complete diesel power system.
- III. Diesel engine specifications which include:
 - A. The MSHA engine certification number (do not list the specific extension number).
 - B. The manufacturer and model number of the engine.
 - C. Rated speed.
 - D. Maximum brake horsepower at rated speed.
- IV. Cooling system specifications which include:
 - A. A cooling system flow diagram showing:
 - (1) The complete cooling system including all water-cooled components, hoses, engine radiator(s), surge tank(s), etc.
 - (2) Arrows that show the direction of coolant flow.
 - (3) Identification and location of the water temperature sensor(s) and any flow limiters (orifices).
 - (4) Sizes of all cooling system hoses and orifices.
 - B. An elevation drawing showing the height relationship of the engine, safety components, radiator(s), and surge tank(s).
 - C. A procedure describing the proper method of filling the cooling system.

- D. The radiator fan blade material specifications (nonmetallic blades must meet special requirements, see attachments).
- V. The following air intake system drawings:
- A. Flame Arrester(s).
 - B. Flange(s).
 - C. Piping.
 - D. Gasket(s).
 - E. Air Intake Shutoff Device.
 - F. Air Cleaner and its Service Indicator.
 - G. Location of Port for Measuring Total Intake Vacuum.
 - H. A drawing showing the assembly of parts (including hardware).
- VI. The following exhaust system drawings:
- A. Water-Cooled Exhaust Manifold.
 - B. Water-Cooled Exhaust Pipe(s).
 - C. Flange(s).
 - D. Gasket(s).
 - E. Water-Bath Exhaust Conditioner drawings which include:
 - (1) Assembly and details of the conditioner.
 - (2) Water levels:
 - (a) Batch-type conditioners shall show high water and shutdown levels.
 - (b) Make-up type conditioners shall show normal operating and shutdown levels.
 - (3) Usable conditioner water:

(a) Batch-type system shall show usable water contained within the exhaust conditioner.

(b) Make-up type system shall show quantity of water required in water make-up tank.

(4) Location of low water level check port (or other suitable means for checking low water shutdown level).

(5) Drain port(s) location.

(6) Location(s) of low water shutdown and water level control float(s) in relation to internal exhaust conditioner parts.

F. Location of port for measuring total exhaust backpressure.

G. A drawing showing how all of the above parts are assembled (including hardware).

VII. A complete description of the safety shutdown system including:

A. A schematic drawing of the complete safety shutdown system.

B. A written description of how the system functions.

C. Drawings and/or specifications for the following parts:

(1) Coolant Temperature Sensor(s).

(2) High Exhaust Gas Temperature Sensor (if applicable).

(3) Low Water Shutdown Device.

(4) Automatic Fuel Shutoff Device.

(5) Engine Start/Stop Device(s).

(6) Flow Limiter or Orifices.

VIII. A drawing and/or specification(s) for the air compressor (if applicable).

- IX. A power system permissibility checklist (see attached).
- X. Other drawings and specifications necessary for MSHA to determine compliance with the requirements of Part 36.

REQUIRED DRAWING/SPECIFICATION FORMAT

Each sheet of all documents shall contain the following information:

- I. Document Number.
- II. Revision Level.
- III. Company Name.
- IV. Title.
- V. A note stating "Do Not Change without Approval of MSHA".
- VI. Documents shall be in English - or translated into English.
- VII. All information on each document shall be legible.

All drawings shall include material specifications, dimensions, surface finish, weld symbols, and tolerances. MSHA may require additional drawings or specifications when deemed necessary to determine compliance with Part 36.

The application shall be submitted to:

Mine Safety and Health Administration
Approval and Certification Center
Division of Mechanical Safety
RR #1, Box 251, Industrial Park Road
Triadelphia, West Virginia 26059

All applicants may contact the A&CC for additional clarification before submitting an application. The Chief, Diesel Power Systems Branch, is responsible for processing diesel certification applications and can be reached at (304)547-0400.

PREPARATION OF SAFETY COMPONENT SYSTEMS
FOR SHIPMENT TO MSHA FOR TESTING

Tests are conducted at the A&CC or other appropriate place(s) determined by MSHA. Manufacturers having testing performed at the A&CC must provide the special mounting stand and system

standards as per this section. The following requirements apply to systems up to 400 horsepower. Special instructions are available for engines larger than 400 horsepower.

I. General Requirements.

- A. All equipment is representative and in safe working order.
- B. The shipping crates of safety component systems shall be designed to allow:
 - (1) Easy handling by a forklift without crate modification.
 - (2) Easy reuse at conclusion of tests. MSHA will not reconstruct poorly designed shipping crates.
- C. Protect all hose, line and threaded fittings and labeled as per function.
- D. A completely assembled safety component system must include the following:
 - (1) A Part 36 MSHA certified diesel engine.
 - (2) A complete engine intake system except for the air cleaner.
 - (3) A complete engine exhaust system, excluding dilution system.
 - (4) An engine coolant system including radiator, fan, etc.
- E. Engines should preferably have electric start; however, we permit other totally complete starting systems.
- F. Set up engine to the engine manufacturer's specifications. NOTE: The engine fuel pump is adjusted such that the fuel rate at rated speed is set between the nominal rate and the maximum specified limit. Applicants shall supply MSHA with evidence of calibration of the fuel pump.
- G. Set the engine's fuel system for sea level operation (1000 ft. and below).

- H. All test ports on the system are readily accessible.
- I. Provide the system with properly located (balanced) lifting lugs to facilitate handling with an overhead crane.
- J. MSHA inspects the internal parts of the exhaust conditioner after testing. MSHA will gain entrance to the internals of an exhaust conditioner constructed of mild steel using an oxy-acetylene cutting torch. Applicants constructing the exhaust conditioner from stainless steel are responsible for cutting open the exhaust conditioner for MSHA. NOTE: Exhaust conditioner must be constructed of corrosion-resistant materials. For MSHA testing only, they may be constructed of mild steel.
- K. Provide an ample supply of engine lubricating oil and 50/50 glycol engine coolant with the system.

II. Driveshaft Adapter Requirements.

Supply a flywheel adapter plate and attach it to the flywheel of the engine with grade 8 fasteners. Install locking devices to prevent loosening of the fasteners. For location and size of the threaded holes in the adapter plate, required to mate with MSHA's driveshaft flanges for dynamometer and explosion testing, see Figure 1.

III. Engine Interface Requirements for Dynamometer Tests.

- A. Provide a 1/8-inch (minimum) female pipe fitting (N.P.T.) for the oil pressure port.
- B. Provide a 1/8-inch (minimum) female fitting (N.P.T.) for measuring total intake vacuum.
- C. Provide a 1/8-inch (minimum) female fitting (N.P.T.) for measuring turbocharger boost pressure (if applicable).
- D. Provide a 1/8-inch (minimum) female fitting (N.P.T.) for measuring total exhaust backpressure.
- E. Provide a single six-inch tubing (O.D.) adapter at least four inches long to the air intake system. The location shall be readily accessible and suitable for the attachment of MSHA's six inch inlet tubing.

- F. Provide a single six- or four-inch female fitting (N.P.T.) at the outlet of the exhaust system.
- G. Provide a 1/8-inch (minimum) N.P.T. female test port at or near the exhaust conditioner inlet for measuring exhaust gas temperature entering the exhaust conditioner.
- H. Install a pressure gauge for monitoring the water pump outlet pressure.
- I. Supply the following 1/8-inch (minimum) N.P.T. ports in the engine/component coolant system to provide the following coolant temperatures (if applicable):
 - (1) Engine in.
 - (2) Engine out.
 - (3) Exhaust pipe out.
 - (4) Exhaust manifold out.
 - (5) Turbocharger out (if applicable).

These ports are minimum requirements. MSHA may require additional ports depending upon the system design.

- J. Provide 3/8-inch female fittings (N.P.T.) for the fuel inlet and return connections.
 - K. Provide a water reservoir tank with complete supply system for make-up type exhaust conditioner systems.
- IV. Special Requirements for Explosion Tests.
- A. Provide the following female N.P.T. ports:
 - (1) Intake System: The following intake system test ports are located in-by the flame arrester:
 - (a) 1/2-inch (minimum), spark plug port, located immediately adjacent to the intake manifold.
 - (b) 1/4-inch (minimum), pressure sensor port, located immediately adjacent to the flame arrester.

(c) 1/8-inch (minimum), thermocouple port, located immediately adjacent to the intake manifold.

(2) Exhaust System:

(a) 1/2-inch (minimum), spark plug port, located immediately adjacent to the exhaust manifold.

(b) 1/4-inch (minimum), pressure sensor port, located in exhaust pipe immediately adjacent to the exhaust conditioner.

(c) 1/8-inch (minimum), thermocouple port, located in the exhaust pipe immediately adjacent to the exhaust conditioner.

These ports are minimum requirements. MSHA may require additional ports depending upon system design.

B. The overall size of the system shall be such that it will fit within the MSHA explosion gallery (chamber). The critical dimensions of the gallery are shown in Figure 3.

V. Pre-Aligned Stand Requirements.

The complete safety component system on a stand which conforms to the dimensions specified in Figure 2. The area in front of the flywheel housing shall not be obstructed to permit attachment of MSHA's driveshaft and provide clearance for the driveshaft guard.

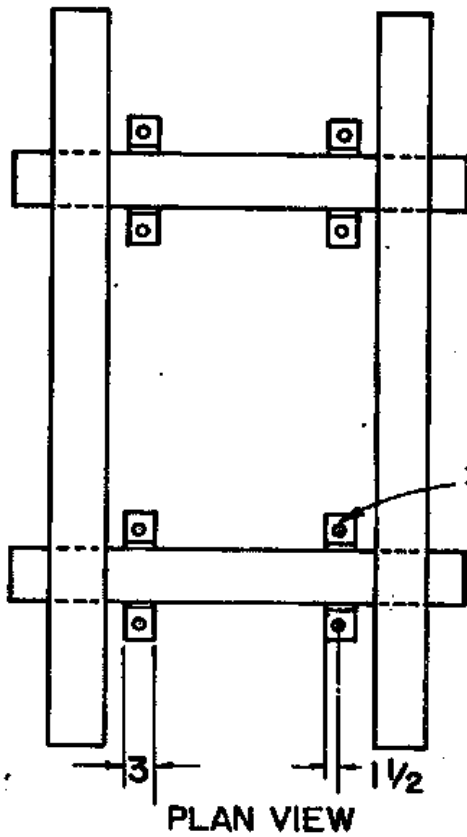

Notes

1. All dimensions in inches
2. Dimensions given are typical for 8 mounting angles
3. Square tubing shown for reference only
4. Tolerance: $\pm 1/16$
5. Not to scale

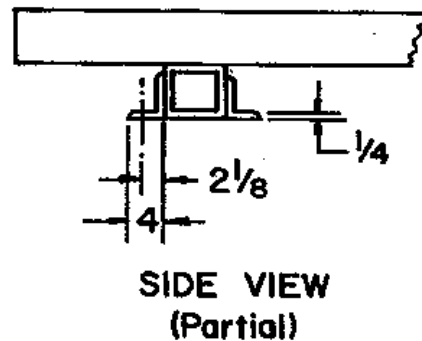
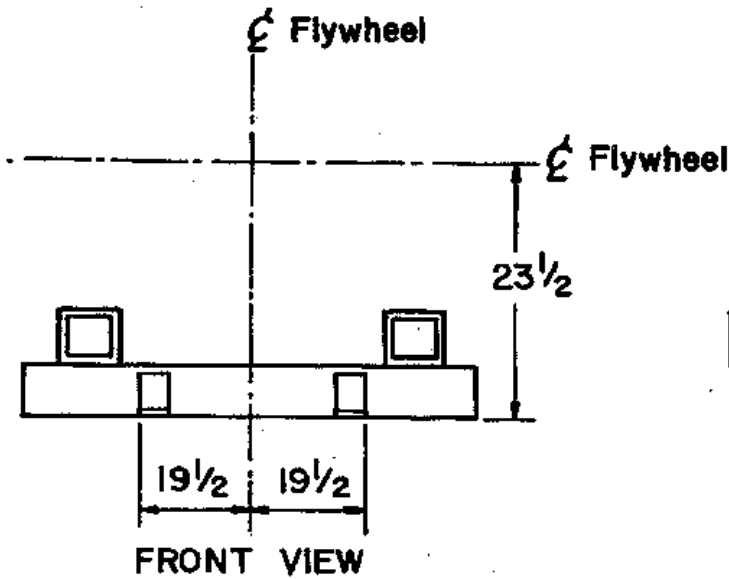

Figure 2.— TEST STAND REQUIREMENTS

Notes

All dimensions in inches
unless noted
Not to scale

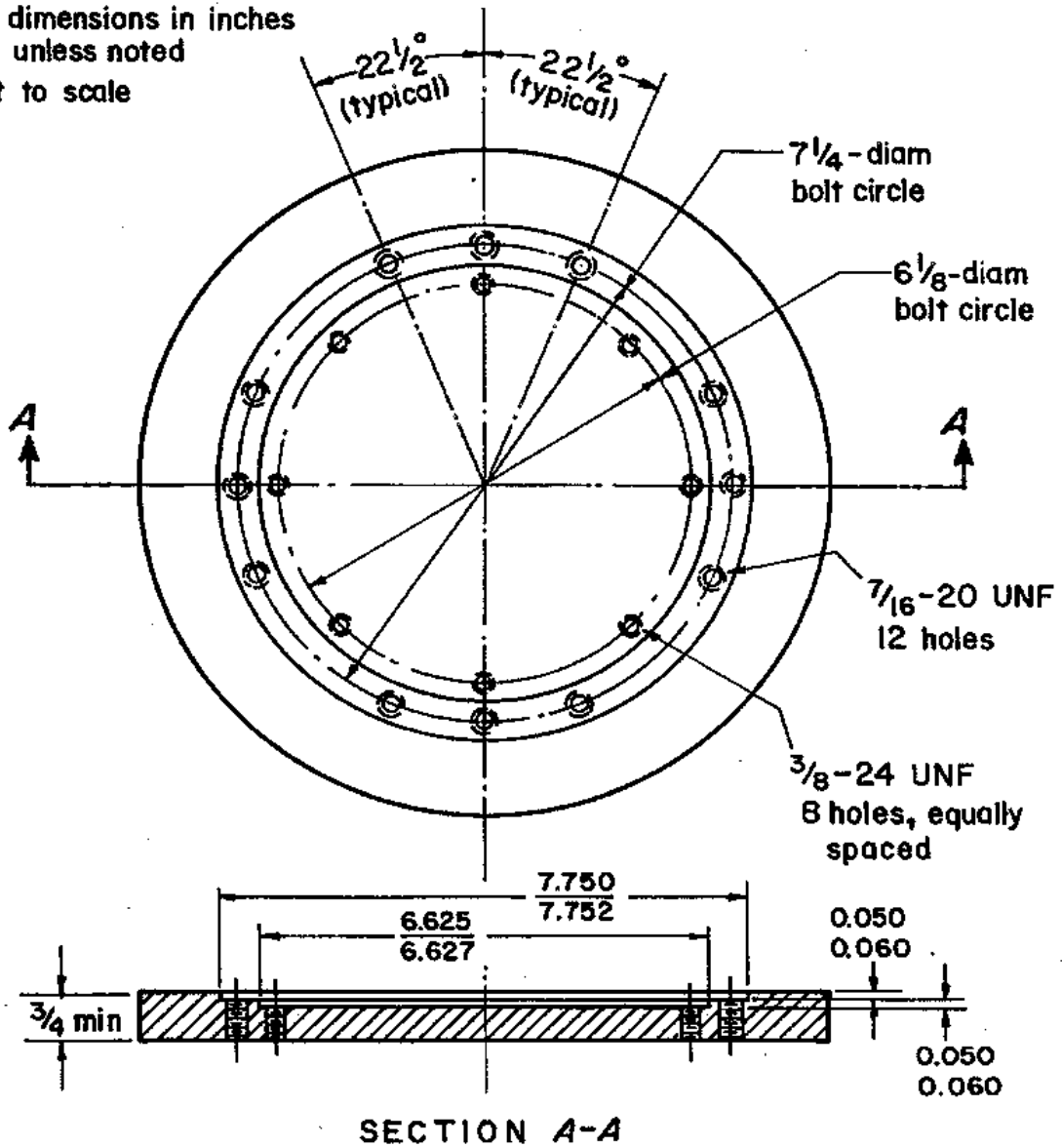

Figure I. - FLYWHEEL ADAPTER PLATE

PL-11-87
1378

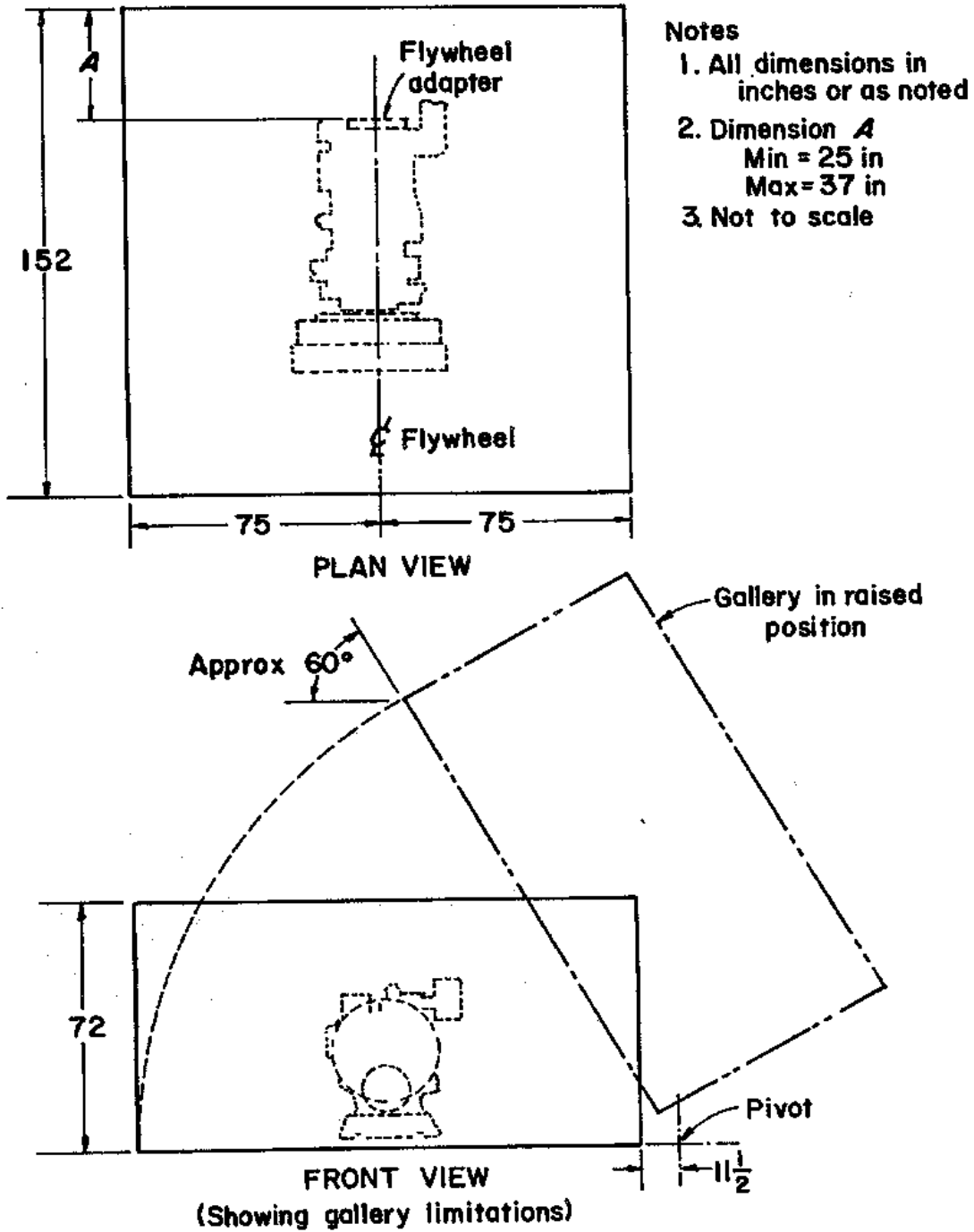

Figure 3.- EXPLOSION GALLERY - Dimensional Limitations