

# Noncommercial Trading in the Energy Futures Market

by Charles Dale and John Zyren

## Introduction<sup>1</sup>

How do futures markets affect spot market prices? This is one of the most pervasive questions surrounding futures markets, and it has been analyzed in numerous ways for many commodities. Early researchers concentrated on the relationship between spot prices and the "term structure" of futures prices, i.e., the instantaneous values of futures prices with different maturities. For example, Holbrook Working's cost-of-storage concept was shown to determine the term structure of futures prices in storable agricultural commodity futures (Brennan, 1958). Vignola and Dale (1980) showed that the cost-of-storage concept can also be applied to financial futures markets, so that the term structure of Treasury bill futures was determined by financing costs, not by the unbiased expectations hypothesis of the term structure of interest rates. More recently, numerous studies have examined various aspects of pricing and efficiency in nonagricultural commodities.

An alternative way to examine the price impact of futures markets is to ask whether or not those traders who have no commercial interest, commonly referred to as "speculators," can destabilize prices. Despite a vast body of research showing that futures markets are generally efficient, questions about the role of speculators repeatedly arise. This paper utilizes a new approach to the examination of price impacts of speculators on futures markets. It focuses initially on specially obtained data on commodity "pools," which are large funds of money that may move quickly between and across futures markets and other financial markets; it then broadens the scope to include large noncommercial traders in general. This research also differs from previous work in its comparison and analysis of the holdings of large commercial and noncommercial traders, and demonstrates that changes in noncommercial

positions in energy futures markets are closely related to price changes in those markets. The paper concludes that noncommercial traders are likely to switch between markets and add to "hot money" flows, and that noncommercial traders follow price trends in energy markets rather than set them.

## Background

The growth of energy futures markets has had a dramatic impact on the way in which crude oil and petroleum products are marketed (Dale, 1991). As a result, the Energy Information Administration (EIA), the U.S. Government agency having the mission of producing objective analyses of energy markets, often has the task of answering Congressional requests for information about futures markets. For example, during the Persian Gulf War, Congress had numerous questions about the role that futures market speculators may have played in driving up crude oil prices. Such fears were shown to be unfounded (Energy Information Administration, 1990), as the relative amount of speculative activity did not increase during the price rise, and the massive selling by hedgers in futures markets actually helped to dampen the crude oil price increase.

Recently, the energy trade press has contained a number of stories about large speculative funds of money trading in energy futures.<sup>2</sup> Whenever futures price spikes occur, whether caused by problems in the Middle East which push up crude oil prices, or cold weather in the United States that drives up heating oil prices, questions from the Congress about the role of speculators inevitably follow. Thus, it is important for EIA to understand how speculative funds operate, in both normal markets and crisis situations.

While EIA must monitor energy futures markets, the combination of market complexity and budgetary restrictions makes it necessary to frequently work with other Government agencies. In particular, the Commodity Futures Trading Commission (CFTC)

---

<sup>1</sup> This paper was presented at the International Energy Workshop, International Institute for Applied Systems Analysis, Laxenburg, Austria, June 20-22, 1995. The authors thank John Fenton, Annette Pruss, and George Wang of the Commodity Futures Trading Commission, Washington, DC, for their invaluable assistance.

---

<sup>2</sup> See, for example, *Bloomberg Oil Buyers Guide* (1995a, 1995b).

regulates the futures markets and has a unique combination of databases and staff expertise that can assist EIA. Much of the present work was designed to enable EIA and the CFTC to work together to exchange publicly available information about the functioning of the energy futures markets in areas such as the price effects of noncommercial traders. One important group of noncommercial traders is called "pools." A first step is to understand exactly what "pools" are.

Commodity pools are commonly referred to as "mutual funds for commodity futures," because a large number of investors can combine their money to invest in futures markets in a manner similar to that involved in investing in mutual funds for stock and bond markets. One early example of such pools was launched in 1968, when economist Paul Samuelson and several associates pooled \$2 million of their own money to trade in agricultural commodity futures; within 12 months they had lost half of their original investment (Crawford, 1994). In current practice, pools are much more complicated than that. The CFTC defines a "pool" as a "collective investment vehicle, usually a limited partnership because of the unavailability of pass-through tax treatment for corporate forms, that engages in futures transactions either exclusively or in conjunction with other investment activity" (Holum, 1994). Commodity Pool Operators (CPOs) must register with the CFTC through the National Futures Association, a private trade group to which the CFTC has delegated its registration authority. CPO's, in turn, usually delegate the operations of their pools to one or more Commodity Trading Advisors (CTAs) who are professional money managers who must also register with the CFTC. Pools may make public offerings, a step which would require registration with both the CFTC and the Securities and Exchange Commission (SEC),<sup>3</sup> or remain private, by restricting themselves to no more than 35 sophisticated investors, a step which would exempt them from SEC, but not CFTC, registration.

A similar type of "collective investment activity" that has recently received much more attention than pools is a "hedge fund." The term "hedge fund" is confusing, because a "hedger" in futures markets refers to an entity that normally has owned or anticipates owning the underlying commodity, while a "hedge fund" need not deal in futures at all. The

term "hedge fund" arose in the 1960s and referred to what was, for that time, a sophisticated vehicle for simultaneously buying and selling corporate equities. More recently, this term began to encompass funds that had operations with government securities, foreign currencies, futures and options, and even merger and acquisition activity. There is in fact today no definition of "hedge fund" for regulatory purposes, and the term now refers informally to "collective investment vehicles organized to avoid complying with most securities laws" (Holum, 1994).<sup>4</sup> But, regardless of how much or how little the funds participate in other activities, if the hedge funds trade futures contracts and have a large number of customers they must register with the CFTC as commodity pool operators.

Hedge funds received widespread public attention in September 1992, when George Soros, who runs the Quantum Fund, announced that he had made \$1 billion speculating on the devaluation of the British pound (Jenkins, 1994). Since then, central bankers, finance ministers, and the U.S. Congress have all expressed concerns about the possible effects that hedge fund activity can have on world financial markets. Hedge funds have recently begun trading in energy futures.

The relationship between commodity pools and hedge funds is shown in Figure FE1. The CFTC has regulatory jurisdiction over the trading of futures contracts and options on futures contracts for both pools and hedge funds. Pools are themselves part of the broader class of traders called "speculators," who will be referred to here by the less inflammatory term "noncommercials."

Relatively little prior research has been done on commodity pools, largely due to a lack of data. Brorsen and Irwin (1985) examined the rates of return of commodity pools as a test of futures market efficiency and concluded that futures markets are efficient. They also analyzed public commodity pools (Irwin and Brorsen, 1985) and concluded that they are useful for portfolio diversification. Cornew (1986) analyzed private commodity pools and concluded that pools can be modeled better as speculative instruments rather than as investment vehicles. He later concluded (Cornew, 1988) that both public and private pools appear to be speculative investments

---

<sup>3</sup> The SEC registers the *offering*, while the CFTC registers the *offeror*. Technically speaking, the CFTC registers the CPO, not the pool itself.

---

<sup>4</sup> They can avoid securities laws by, for example, restricting their owners to a small number of sophisticated investors who can afford to invest substantial sums of money.

HEDGE FUNDS

COMMODITY  
POOLS

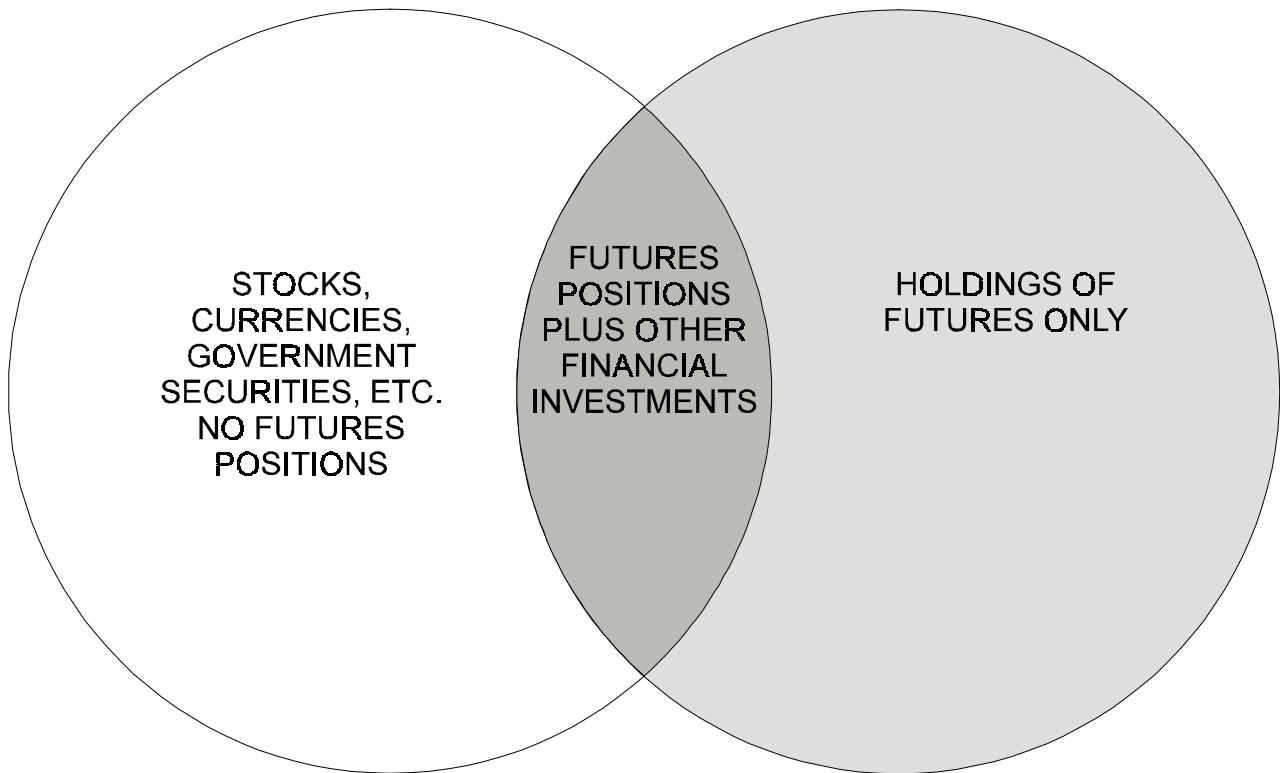

Figure FE1

Commodity Pool Operators (CPO's) that must register with the Commodity Futures Trading Commission (shaded areas) encompass collective investment vehicles that trade commodity futures or options on commodity futures.

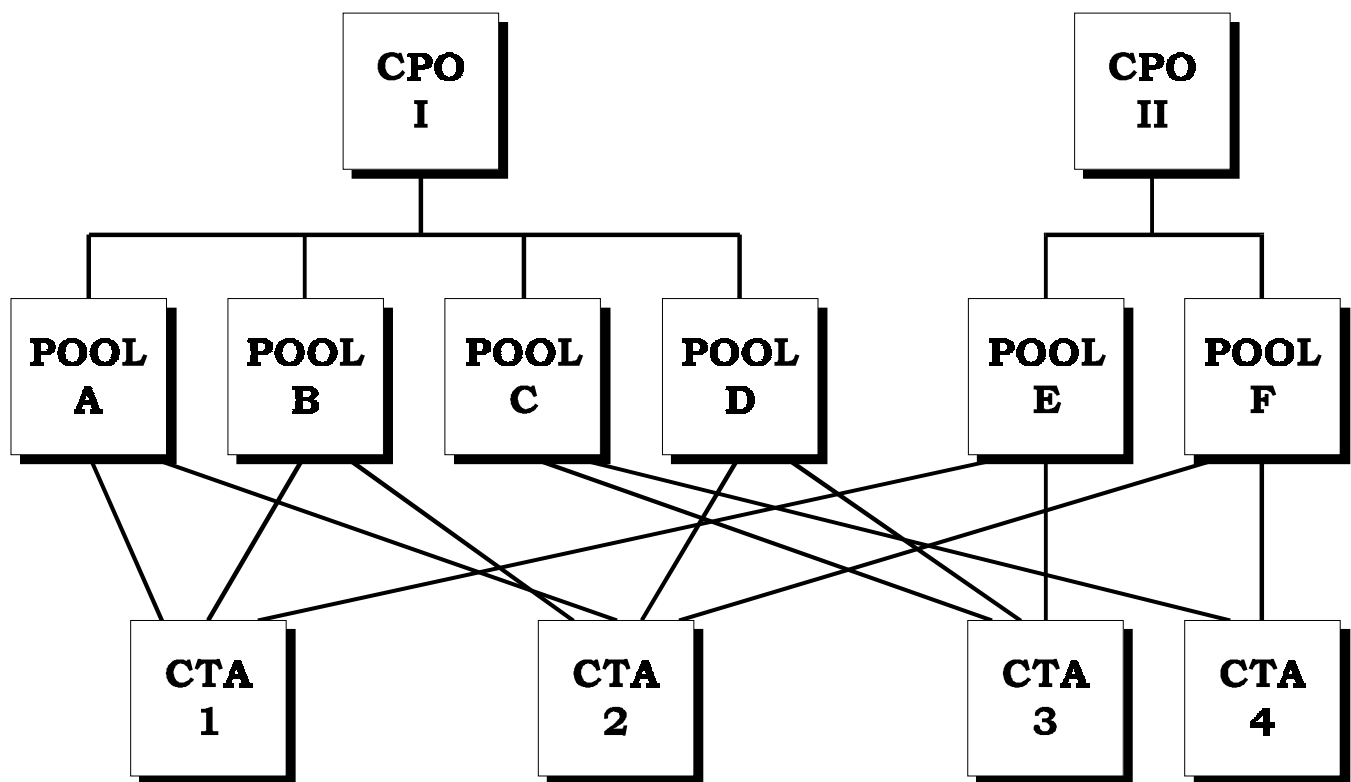

Figure FE2

Commodity Pool Operators (CPO's) may operate several pools, each of which is run by one or more commodity trading advisors (CTA's).

with high expenses relative to either money controlled or net asset value. Edwards and Ma (1988) examined pool prospectuses and concluded that the information they contained was not a good indicator of future performance

As shown in Figure FE2, a pool operator may establish several pools that are run by several commodity trading advisors. These same advisors, in turn, may be involved in trading futures for several different commodity pool operators. The result is a complex web of interlocking relationships between pools and advisors.

More recently, the Commodity Futures Trading Commission (1991) surveyed pools and drew the following conclusions:

- In 1988, 1200 pools had \$7.8 billion in net assets,<sup>5</sup> but only 65 large (i.e., assets over \$10 million) CPOs controlled 94 percent of the total. Among the large CPOs, only about 8 percent of the assets were held for trading futures and options.
- Pools rarely held more than 10 percent of the outstanding contracts in a futures market.
- There was a statistical tendency for pools to buy and sell together, but the relationship was not a strong one and the net effect on futures prices was unclear.

## Commitment Report Data

The Commodity Futures Trading Commission maintains a large trader reporting system through which "futures commission merchants" (i.e., brokers) are required to report traders' positions above certain reporting levels. These reporting levels vary by market, depending upon, among other things, the size of the futures markets. Generally, reporting levels are set to get most (about two-thirds) of the total "open interest," which is the number of contracts outstanding.<sup>6</sup>

---

<sup>5</sup> In contrast, by 1994 only 4 hedge funds -- Quantum, Tiger, Steinhardt, and Omega -- had \$25 billion under management (*Economist*, 1994).

<sup>6</sup> Getting a complete picture requires knowledge of positions held by foreigners. Even those pools which are organized offshore, have no U.S. participants, and have a non-U.S. CPO and CTA are subject to the CFTC's large trader reporting

According to staff in the CFTC Division of Economic Analysis, in 1994 the minimum reporting levels for holdings in any one contract month were 150 contracts of unleaded gasoline, 175 contracts of heating oil, and 300 contracts of crude oil; the contract size was 1,000 barrels, or 42,000 gallons. The traders had also to specify whether they ever were "commercial" traders or "noncommercial" traders. Commercials normally own or anticipate owning the physical product and may use the markets for "hedging" to take an offsetting position in the futures market in an attempt to lock in a cost or profit margin. "Noncommercial" traders are subject to limits on the total positions they may hold in futures contracts.

Using data from its large trader data reporting system, the CFTC publishes certain aggregate position data broken out by position sizes of commercial and noncommercial traders.<sup>7</sup> A sample excerpt from a CFTC commitment of traders report for unleaded gasoline is shown in Table FE1. Of 65,380 long and short contracts outstanding during that month, 48,377 long contracts (74 percent of the total) and 52,927 short contracts (81 percent of the total) were held by traders who had more than the minimum reporting level of 150 contracts. Most of the reportable contracts were held by commercial traders: 42,900 of the long contracts and 48,316 of the short contracts.

The reportable noncommercial contracts are first subdivided into "long only," or owning only contracts to purchase the underlying commodity at a future date, or "short only," meaning owning only contracts to sell the underlying commodity at a future date. These classifications are of interest because they help to show the net positions of the noncommercial traders. If noncommercials are long in some contract months but hold equal short positions in other months of the same type of futures contract, they are placed in a separate "spreading" category. Table FE1 shows that 1,987 long and short contracts were thusly offset. Also, 3,490 long contracts and 2,624 short contracts were held by noncommercials who did not have offsetting contracts in other months.

The CFTC also reports the number of traders in each category. For the data in Table FE1 there were 13 long only and 11 short only reporting noncommercial traders, and 8 noncommercial spread traders. There

---

requirements.

<sup>7</sup> The CFTC published their data twice a month beginning in 1986, but since October 1992 they have reported the data weekly.

Table FE1. UNLEADED GASOLINE, N.Y. HARBOR - NEW YORK MERCANTILE EXCHANGE  
 COMMITMENTS OF TRADERS IN ALL FUTURES COMBINED, MARCH 28, 1995  
 (Contracts of 42,000 U.S. Gallons)

Total Open Interest	Reportable Positions								Nonreportable Positions	
	Noncommercial				Commercial		Total			
	Long or Short Only		Long and Short (Spreading)		Long	Short	Long	Short	Long	Short
65,380	3,490	2,624	1,987	1,987	42,900	48,316	48,377	52,927	17,003	12,453

Source: Commodity Futures Trading Commission (1995).

were 45 long and 45 short reporting commercial traders.<sup>8</sup>

It is important to note that the CFTC commitment data refer to all types of large traders. There is no distinction between pools, hedge funds, or any other type of noncommercial trader, such as a pension fund. It is also not immediately clear how the "nonreportables" category should be used in analysis. It might be assumed that, because these traders have relatively small positions, they are all noncommercial traders, but does this category also include some commercial traders that are hedging? While for most markets the nonreportable category may indeed consist of mostly speculators, the heating oil market in particular has many small oil dealers who hedge in the futures market but don't have positions large enough to be reportable. Thus, care must be taken when deciding how to use the commitment reports for analysis.

### Special Pool Data Collection

The CFTC provided EIA with position data from its large trader database on "managed money traders," i.e., CPO's, CTA's, hedge funds, and account executives registered as associated persons who control customer accounts. Hereafter, the term "pools" will be a shorthand term for this broader category of

<sup>8</sup> There is other information on the commitment reports, which were originally designed for agricultural commodities to show the differences in holdings between different crop years. Since "crop years" is not a useful concept in energy futures markets, the other types of reported data are ignored here.

managed money traders. The CFTC gathered specific pool data for the 6-month period of April 1994 through September 1994 and calculated the long and short positions of pools for a number of commodities. The present work initially used this pool data for energy futures, with several objectives. First, the 6-month period covered by pool data was examined in detail to seek relationships between pool positions and prices. Second, if proxies in the weekly commitment of traders data can be found that adequately represent pool activity, then the routinely available commitment reports from the CFTC can be used not only for the analysis in this paper but also to assist EIA in monitoring conditions in energy futures markets.

Figure FE3 shows nearby futures prices and Figure FE4 shows the corresponding pool positions for unleaded gasoline. While short positions were negligible until mid-August, long pool positions tracked futures prices extremely closely. Those figures invited further study.

### Hypotheses

It is difficult to formulate testable hypotheses about noncommercial trading activity. However, two distinct types of activity can be analyzed. First, there is the question of intermarket activity, or what might be referred to as a "hot money" hypotheses, i.e., do large noncommercial traders tend to concentrate in a single market or do they shift large sums between different markets at the first sign of a possible higher rate of return? The sudden shifting of large sums of

**Figure FE3. Nearby Gasoline Futures Price**

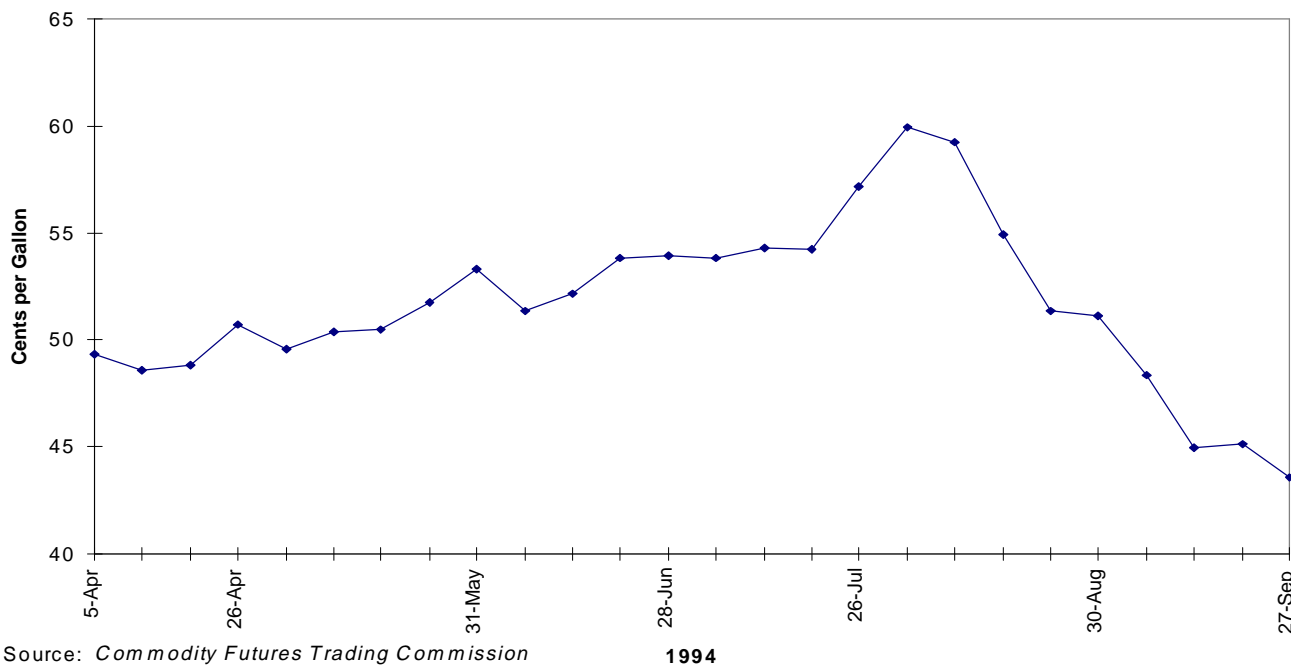

**Figure FE4. Percent of Open Interest Held by Pools**

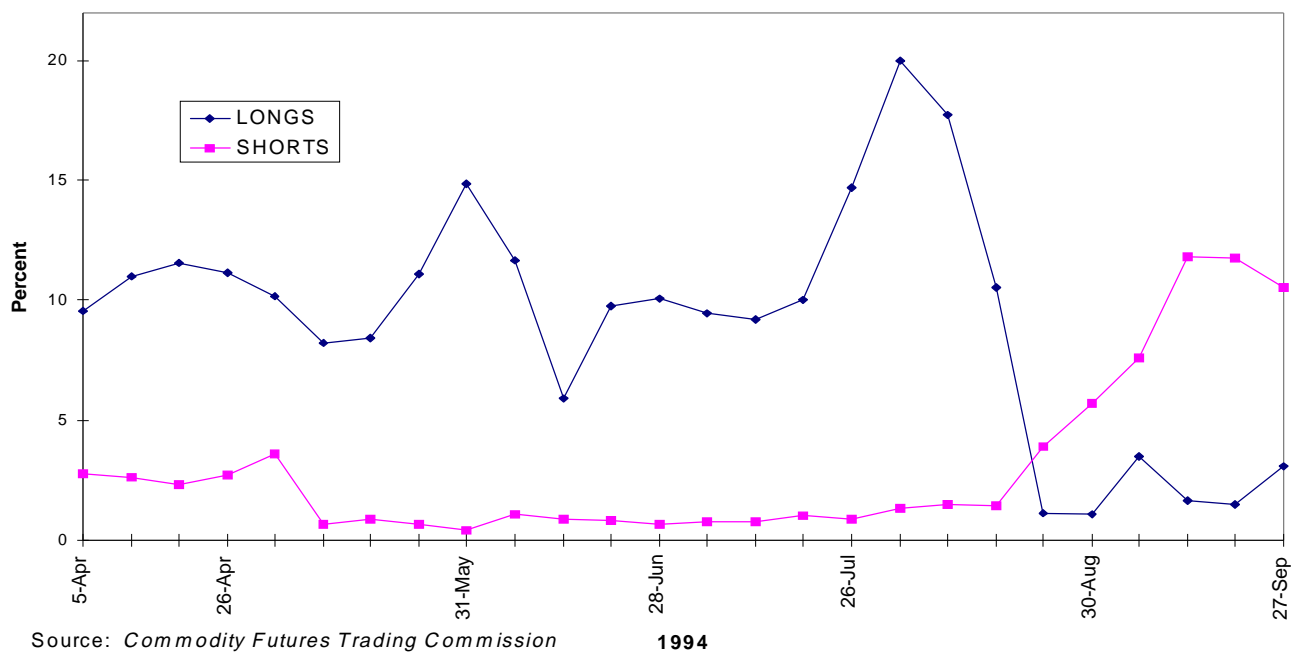

so-called "hot money" between markets presents a potential for destabilizing those markets.<sup>9</sup>

Second, there are questions of how large noncommercial traders affect prices in futures markets. There are three possible ways that trading activity can affect prices: 1) noncommercial may be *price setters* when their trading activity is an important determinant of the price level; 2) noncommercial may be *trend followers* when they don't determine prices but merely try to follow perceived longer-term price trends, either up or down; 3) finally, there may be no relationship whatsoever between noncommercial trading and prices. Regression analyses can be conducted to examine these questions. The following section shows that: 1) noncommercial systematically shift their contract holdings between energy futures markets and Treasury bond futures markets, and 2) they follow price trends, rather than cause them.<sup>10</sup> Further examination of this hypothesis is discussed below, where regression analysis is used and commercial and noncommercial traders are compared.

## Regression Results - Noncommercial Traders

The regression results in Table FE2 and Table FE3 show the behavior of noncommercial traders.<sup>11</sup> Each

---

<sup>9</sup> An implied assumption is that the hot money constitutes the part of the pools' overall portfolios that is dedicated to maximizing returns at high risk. This would explain their rapidly shifting behavior in the absence of a clear budget constraint. As noted earlier, only about 10 percent of pools' holdings were in futures related contracts.

<sup>10</sup> Subsequent to the completion of this research, in an interview with hedge fund operator George Soros, his trading activity was characterized as that of a "trend follower" (Fromson, 1995). This anecdotal evidence from the most famous hedge fund operator supports the conclusions reached in this paper.

<sup>11</sup> The empirical model used for this investigation has the general form

$$\Delta C_i = f(\Delta P_i, \Delta P_{wti}, \Delta P_{tb}, \Delta CN_j)$$

where  $\Delta$  means the weekly change,  $C_i$  represents the number of contracts (long or short) of noncommercial traders,  $P_i$  (in the heating oil and gasoline equations) is the corresponding "nearby," i.e., next expiring, futures contract price of heating oil or unleaded gasoline,  $P_{wti}$  is the nearby crude oil futures

column represents a different equation for changes in contract holdings. An important characteristic of the estimated coefficients is whether they are statistically significant. This is noted by the asterisks next to those numbers, indicating whether they were estimated to be significantly different from zero. For the present context, the most important characteristic of the statistically significant terms is their sign: a significant positive coefficient means that if the parameter increases, then the number of contracts associated with the parameter increases, e.g., if WPRICE, or crude oil futures prices, increase, then the number of long crude oil futures contracts will increase. The opposite is true for minus signs. Finally, the last 4 rows are important primarily for analysis purposes. The statistically significant AR(1) and AR(3) ("autoregressive") terms mean that changes in contract holdings in that week might depend partly on changes that occurred 1 or 3 weeks ago. This is a common effect with highly seasonal commodities, such as heating oil. The adj. ("adjusted")  $R^2$  term refers to the percentage change in the contract holdings that were explained by the equation used, while the last 2 rows refer to other statistical measures of the quality of the regression equations.

The important regression results may be summarized as follows. First, there were statistically significant *positive* coefficients for every "nearby," i.e., next expiring, futures contract price in the regression for the number of long holdings for that contract, e.g., a price increase of crude oil led to an increase in long crude oil contract holdings. Similarly, there were statistically significant *negative* coefficients for prices that correspond to short holdings, e.g., a price increase of crude oil led to a decrease in short crude oil contract holdings. These results mean that in the same weekly period, a price rise in nearby futures contracts is associated with a purchase of additional long contracts and a selling of short contracts. This contemporaneous correlation strongly suggests that energy traders follow price trends, they don't set them. They buy on price rallies and sell into price dips.

Secondly, The negative coefficient for Treasury futures prices in the long crude oil equation means that during a particular weekly period, a decrease in T-bond prices is associated with an increase in long crude oil contract holdings. This gives support for evidence of hot money activity. If Treasury bond

---

contract price,  $P_{tb}$  is the nearby Treasury bond futures contract price, and  $CN_j$  represents the net positions of related futures contracts.



**Table FE2. REGRESSION RESULTS FOR LONG NONCOMMERCIAL CONTRACT HOLDINGS**  
 October 6, 1992, through June 27, 1995

Parameter	Noncommercial Long Contracts (dependent variable)			
	$\Delta$ Crude Oil	$\Delta$ Gasoline	$\Delta$ Heating Oil	$\Delta$ TreasuryBonds
$\Delta$ WNCETLNG		0.0142 (0.0237)	-0.0123 (0.0267)	0.1848** (0.0926)
$\Delta$ MNCETLNG	0.2507 (0.1795)		0.1628** (0.0671)	-0.3558 (0.2545)
$\Delta$ HNCETLNG	0.2259 (0.1406)	0.2583*** (0.0467)		0.0898 (0.2002)
$\Delta$ TNCETLNG	-0.0103 (0.0406)	-0.0355** (0.0148)	0.0084 (0.0166)	
$\Delta$ WPRICE	3157*** (924)	-962** (460)	-518 (569)	-2727* (1449)
$\Delta$ MPRICE		499*** (124)		
$\Delta$ HPRICE			790*** (214)	
$\Delta$ TPRICE	-787** (379)	11 (140)	-236 (148)	1807*** (493)
AR(3)			-0.2687*** (0.0849)	
adj. R <sup>2</sup>	0.249	0.358	0.253	0.110
F-Statistic	12.7	16.7	8.8	5.3
D.W. statistic	2.337	2.035	2.027	2.316

The general form of the linear model is described in footnote 11.  $\Delta$  is the weekly change.

WPRICE, MPRICE, HPRICE and TPRICE denote the nearby futures contract price for crude oil, motor gasoline, heating oil, and Treasury bonds, respectively.

WNCETLNG, MNCETLNG, HNCETLNG and TNCETLNG denote the net long positions in noncommercial contracts for crude oil, motor gasoline, heating oil, and Treasury bonds, respectively.

Standard errors appear in parentheses below parameter estimates.

\*\*\* indicates significant at 1% criteria (p-value < 0.01).

\*\* indicates significant at 5% criteria (p-value < 0.05).

\* indicates significant at 10% criteria (p-value < 0.10).

**Table FE3. REGRESSION RESULTS FOR SHORT NONCOMMERCIAL CONTRACT HOLDINGS**  
 October 6, 1992, through June 27, 1995

Parameter	Noncommercial Short Contracts (dependent variable)			
	$\Delta$ Crude Oil	$\Delta$ Gasoline	$\Delta$ Heating Oil	$\Delta$ TreasuryBonds
$\Delta$ WNCETLNG		-0.0345** (0.0157)	-0.0941*** (0.0244)	0.1461 (0.0917)
$\Delta$ MNCETLNG	-0.2344 (0.1456)		-0.3184*** (0.0597)	0.3782 (0.2425)
$\Delta$ HNCETLNG	-0.2103* (0.1140)	-0.0794** (0.0309)		-0.4658** (0.1927)
$\Delta$ TNCETLNG	-0.0334 (0.0329)	-0.0154 (0.0098)	-0.0251 (0.0155)	
$\Delta$ WPRICE	-3639*** (749)	366 (304)	498 (540)	-1975 (1436)
$\Delta$ MPRICE		-400** (82)		
$\Delta$ HPRICE			-483** (200)	
$\Delta$ TPRICE	-187 (307)	114 (93)	-129 (143)	-1804*** (486)
AR(1)			-0.2115** (0.0859)	-0.2637*** (0.0840)
adj. R <sup>2</sup>	0.318	0.369	0.455	0.184
F-Statistic	17.5	17.5	20.5	7.3
D.W. statistic	2.094	2.065	2.054	2.062

The general form of the linear model is described in footnote 11.  $\Delta$  is the weekly change.

WPRICE, MPRICE, HPRICE and TPRICE denote the nearby futures contract price for crude oil, motor gasoline, heating oil, and Treasury bonds, respectively.

WNCETLNG, MNCETLNG, HNCETLNG and TNCETLNG denote the net long positions in noncommercial contracts for crude oil, motor gasoline, heating oil, and Treasury bonds, respectively.

Standard errors appear in parentheses below parameter estimates.

\*\*\* indicates significant at 1% criteria (p-value < 0.01).

\*\* indicates significant at 5% criteria (p-value < 0.05).

\* indicates significant at 10% criteria (p-value < 0.10).

prices are sharply falling, noncommercial traders will liquidate long Treasury bond futures holdings and buy long crude oil futures contracts. Since crude oil futures are the largest and least seasonal of the energy contracts considered here, it is not surprising that noncommercial traders would concentrate most of their intermarket switching there.

## Conclusions

The media often use the term "hot money" to describe investment flows that move quickly between different markets, seeking the highest possible returns. Certainly many noncommercial investment funds, including both commodity pools and hedge funds, would potentially fall into that category. This paper concludes, first, that noncommercial traders follow price trends; they don't set them.<sup>12</sup> Second, noncommercial traders are likely to switch rapidly their holdings between markets. These results are closely related. The fact that noncommercial traders follow price trends means that they are therefore likely to switch between markets and add to overall hot money flows. The amount of money in hedge funds and commodity pools has grown substantially in recent years, so the potential for sudden huge movements of money between markets will remain for the foreseeable future.

Because 1994 was a bad year for many hedge funds, there was widespread belief that money managers would abandon multiple market strategies (Reerink, 1995). In contrast, in the oil futures markets some money managers, particularly in oil futures, seemed not only to be continuing with multiple market strategies, but to be refining them from simplistic tradeoffs between markets to examining each market independently (*Petroleum Intelligence Weekly*, 1995a). This is an interesting area for future research. In any case, the results of this analysis have shown that noncommercials don't set futures prices but, instead, follow price trends. This is an important conclusion.

## Bibliography

*Bloomberg Oil Buyers Guide*. "European Products Plunge as Funds Sell Positions." June 26, 1995a. 8.

---

<sup>12</sup>In the words of one trade press author who saw an early version of this paper, commodity funds "are sheep, not shepherds" (*Petroleum Intelligence Weekly*, 1995b).

*Bloomberg Oil Buyers Guide*. "Money Managers Move Out Of Oil, Into Equities." July 10, 1995b. 3.

Brennan, M. J. "The Supply of Storage." *American Economic Review*, 1958. 48:50-72.

Brorsen, B. W., and S. H. Irwin. "Examination of Commodity Fund Performance." *Review of Research in Futures Markets*, 1985. 4:84-94.

Commodity Futures Trading Commission, Division of Economic Analysis. *Survey of Commodity Pool Operators in Futures Markets With An Analysis of Interday Position Changes*. Washington, DC, January 1991.

Commodity Futures Trading Commission. *Commitments of Traders in Commodity Futures*. Various dates, 1995.

Cornew, R. W. "Note on Initial Margin to Net Asset Value: Average Values for the Commodity Pool Industry." *Journal of Futures Markets*, 1986. 6(3):495-501.

Cornew, R. W. "Commodity Pool Operators and Their Pools: Expenses and Profitability." *Journal of Futures Markets*, 1988. 8(5):617-637.

Crawford, W. B. "Financial Stone Age Buried By Hedge Fund." *Chicago Tribune*. July 18, 1994. 1ff.

Dale, C. "Economics of Energy Futures Markets." *Petroleum Marketing Monthly*, DOE/EIA-0380(91/09). Washington, DC, September 1991, 5-18.

*Economist*. "Hedge Funds: Trimming." July 16, 1994. 73.

Edwards, F., and C. Ma. "Commodity Pool Performance: Is the Information Contained in Pool Prospectuses Useful?" *Journal of Futures Markets*, 1988. 8(5):589-616.

Energy Information Administration. *Petroleum Prices and Profits in the 90 Days Following the Invasion of Kuwait*. SR/OA/90-01. Washington, DC, November 1990.

Fromson, B. D. "Billionaire Bettor." *Washington Post*. October 1, 1995. H1ff.

Holum, B. P. "Statement of Barbara Pedersen Holum, Acting Chairman, Commodity Futures Trading Commission, Before the House of Representatives

Committee on Banking, Finance and Urban Affairs." Washington, DC, April 13, 1994.

Irwin, S. H., and B. W. Brorsen. "Public Futures Funds." *Journal of Futures Markets*, 1985. 5(3):463-485.

Jenkins, I. "Do Hedge Funds Warrant the Torrent of Opprobrium?" *International Herald Tribune*. March 12, 1994. 1-3.

*Petroleum Intelligence Weekly*. "How Hedge Funds Play Off Markets For Fun And Profit." May 29, 1995a. 2-3.

*Petroleum Intelligence Weekly*. "Futures Study Calls Financial Funds Sheep, Not Shepherds." September 18, 1995b. 5.

Reerink, J. "Down Trends In Hedge Funds." *Futures*, February 1995. 24(2):62-68.

Vignola, A. J., and C. Dale. "The Efficiency of the Treasury Bill Futures Market: An Analysis of Alternative Specifications." *Journal of Financial Research*, Fall 1980. 3(2):169-188.