



Texas Carbon Smorgasboard

Sandy Dasgupta
Dasgupta@uta.edu

- **CO₂ : Removal and Ion Chromatography**
- **A size-speciating multi- λ Aethalometer
Wavelength-discriminating Aethalometric
Size-Discriminating Particle Sensor (WASPS)**
Excellent correlation of EC with low wavelength
aethalometry
- **An alternative to thermo-optical carbon
speciation: Photo Assisted Stepwise Wet
Oxidation and CO₂ Sensing (PASWOCS)**

- Carbon dioxide is present in the atmosphere at a concentration of ~400 ppm while one is trying to determine low to sub-ppbv levels of other ionogenic gases.
- *It would be a significant advancement to remove $\text{CO}_2/\text{H}_2\text{CO}_3$ prior to detection.*

Construction of CO₂ removal device (de-CO₂ or CRD)

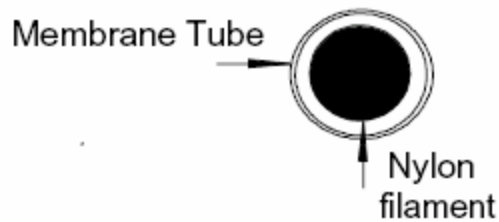
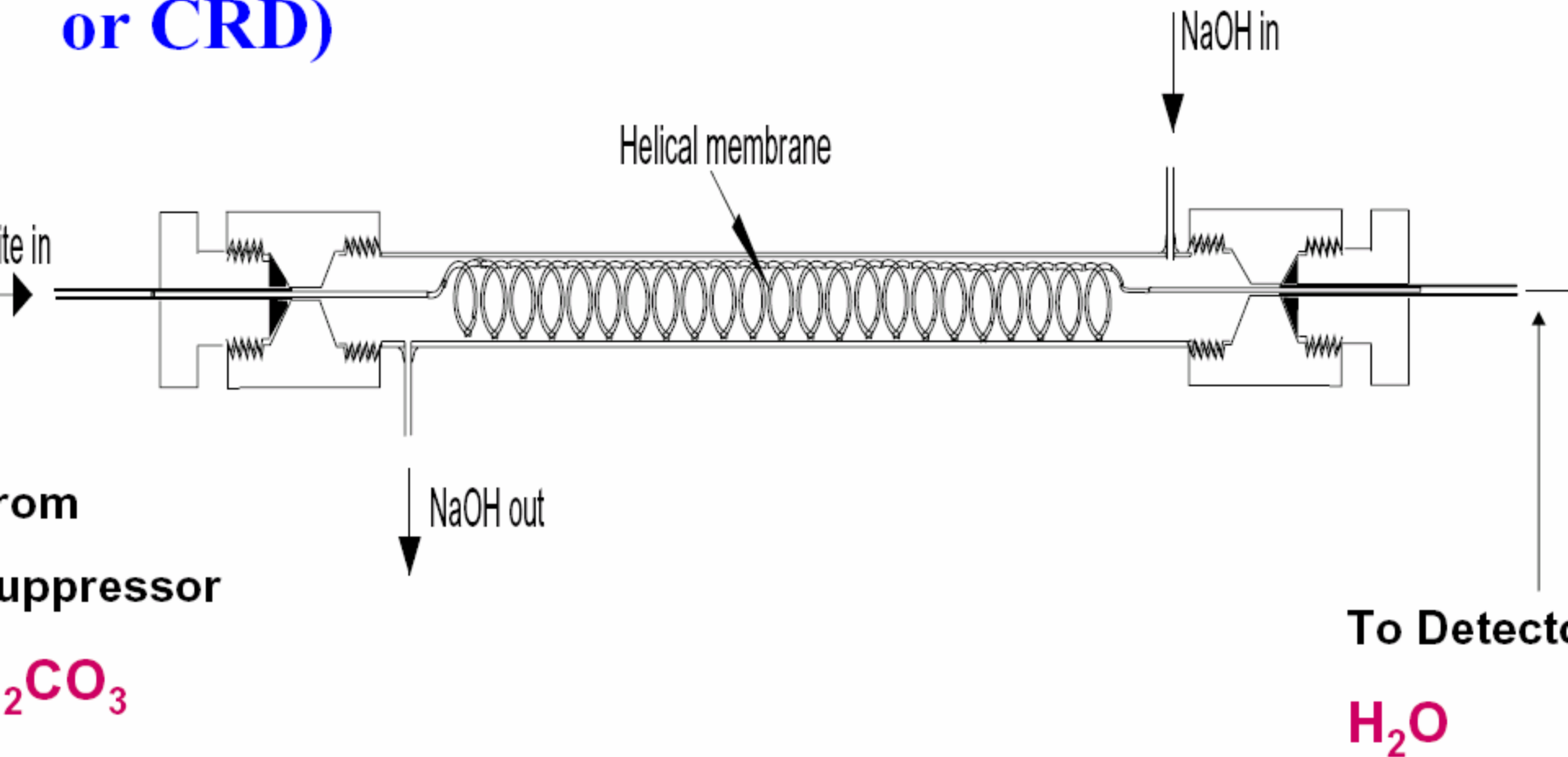

Removal Efficiency of different CRDs

Membrane	Length cm	ID mm	Filament mm	Silicone Coating	% Removal 22 C	% Removal 30 C
Celgard	50	0.4	0.2	Yes	91.5±0.3	96.6±0.6
Celgard	80	0.4	0.2	Yes	95.9±0.1	97.8±0.1
Celgard	100	0.4	0.2	Yes	97.7±0.2	99.4±0.2
Neomecs	50	0.2	No	PP	81.8±0.5	90.5±0.8
Neomecs	50	0.4	0.2	PP	91.5±0.1	92.9±0.2

Lumen flow 1 mL/min; Sink solution: 100 mM NaOH at 0.5 mL/min

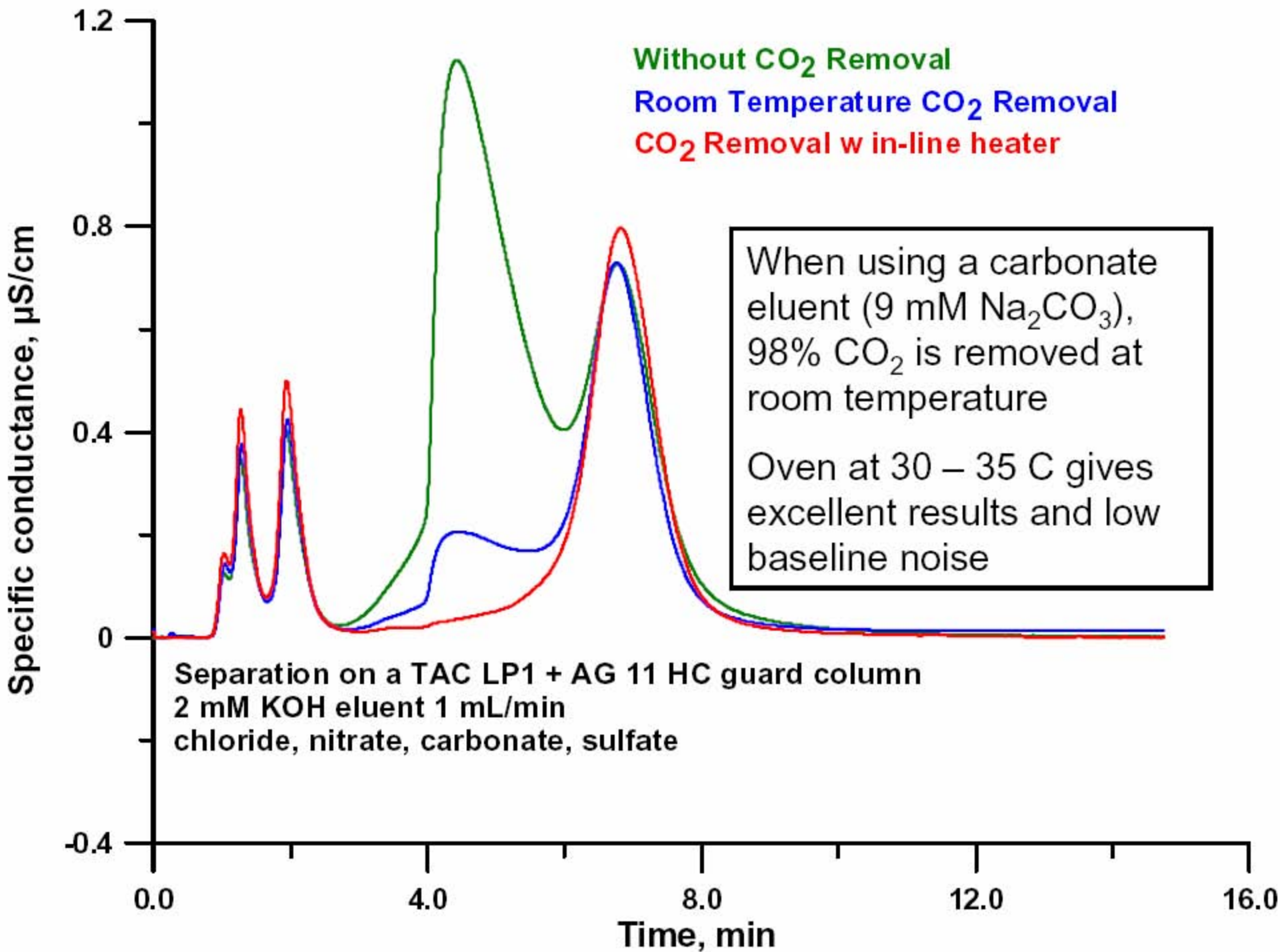

Ambient Measurements in Tampa, FL AG11/AS11 EG 40

(w/o d-CO₂ device) 15.50 mM KOH, 1.50mL/min

vs.

(with) 17.50 mM KOH, 1.4 mL/min

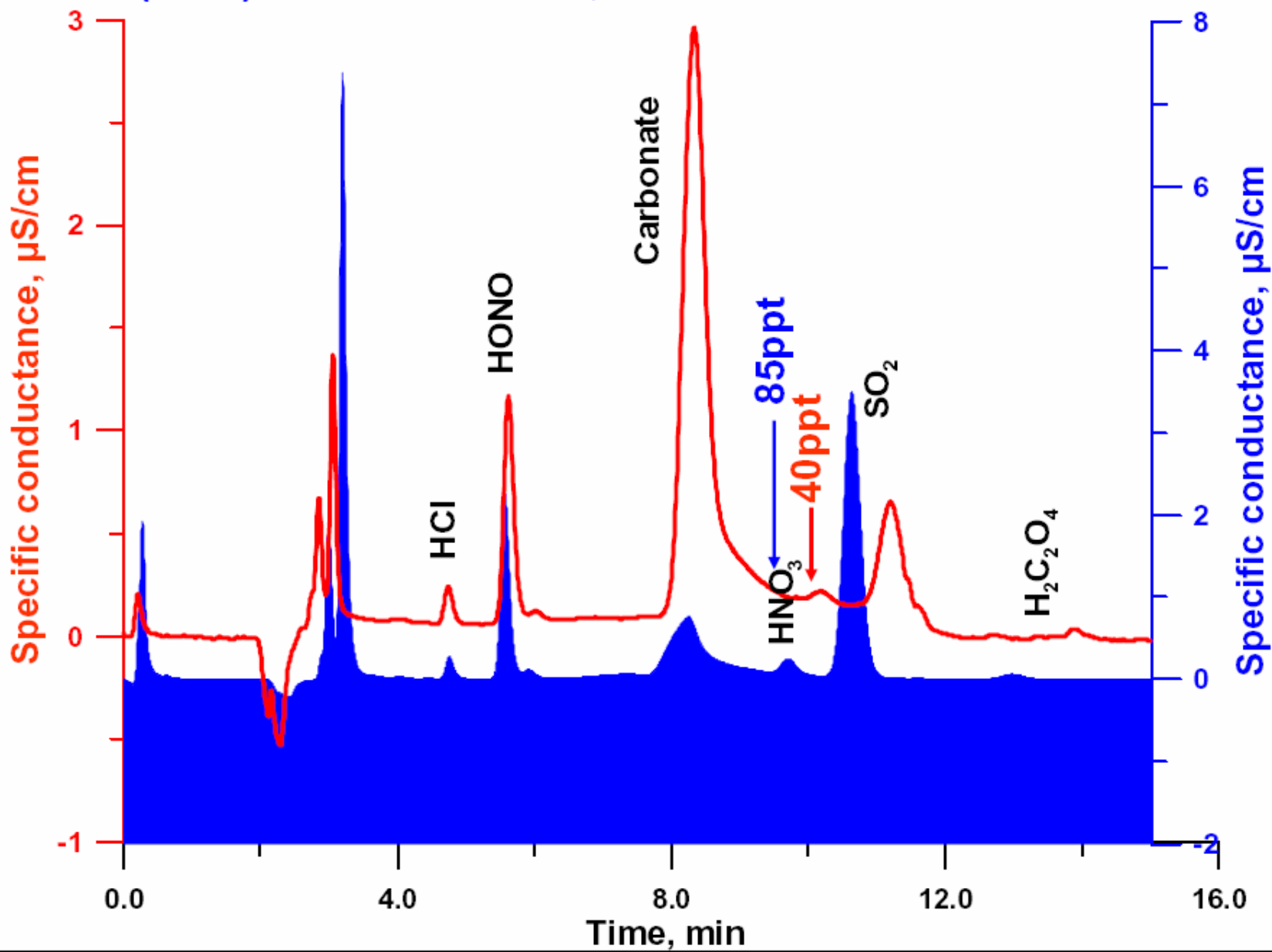

Gas Particle Ion Chromatography (GP-IC) System: Use of CRD in automated System to remove CO₂ from suppressed carbonate eluent

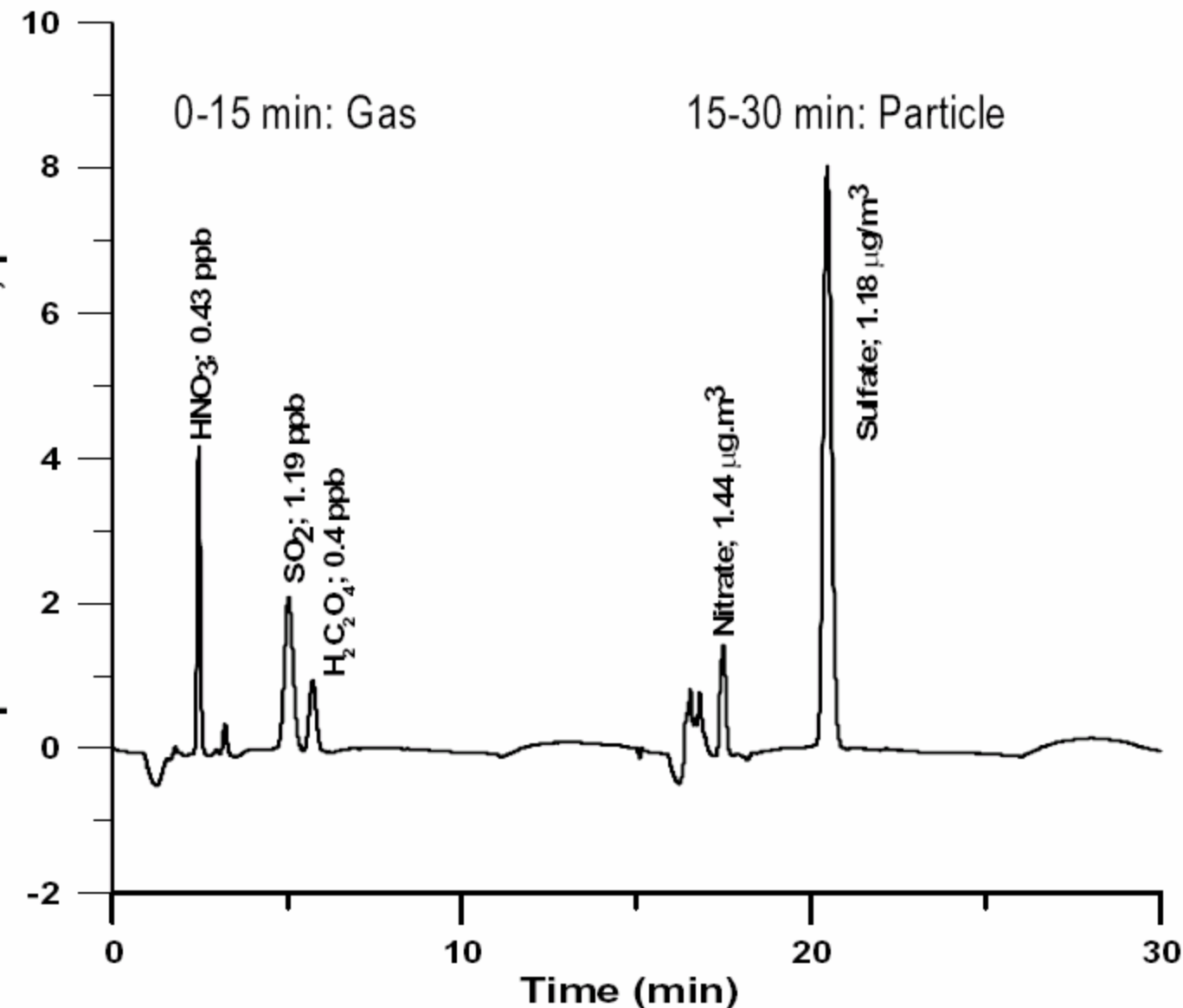

Automated sequential chromatograms of collected gas and aerosol samples with 2.4 mM Na₂CO₃ and 2.3 mM NaHCO₃ eluent, 4X150 mm AG11 column, 1.0 mL/min, 80 cm Celgard CRD, oven at 30°C.

Background:
From ~15μS to
≤1μS

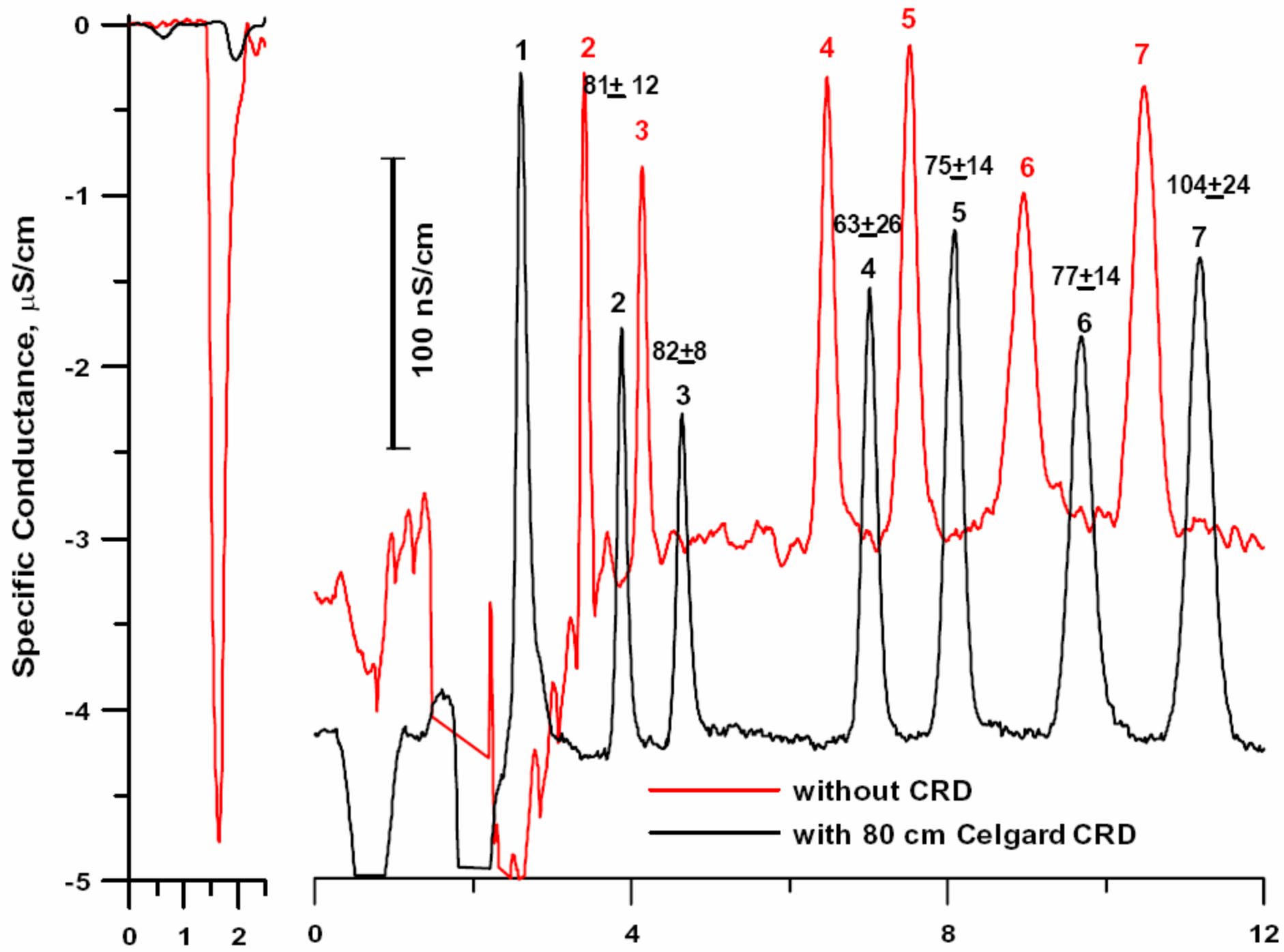

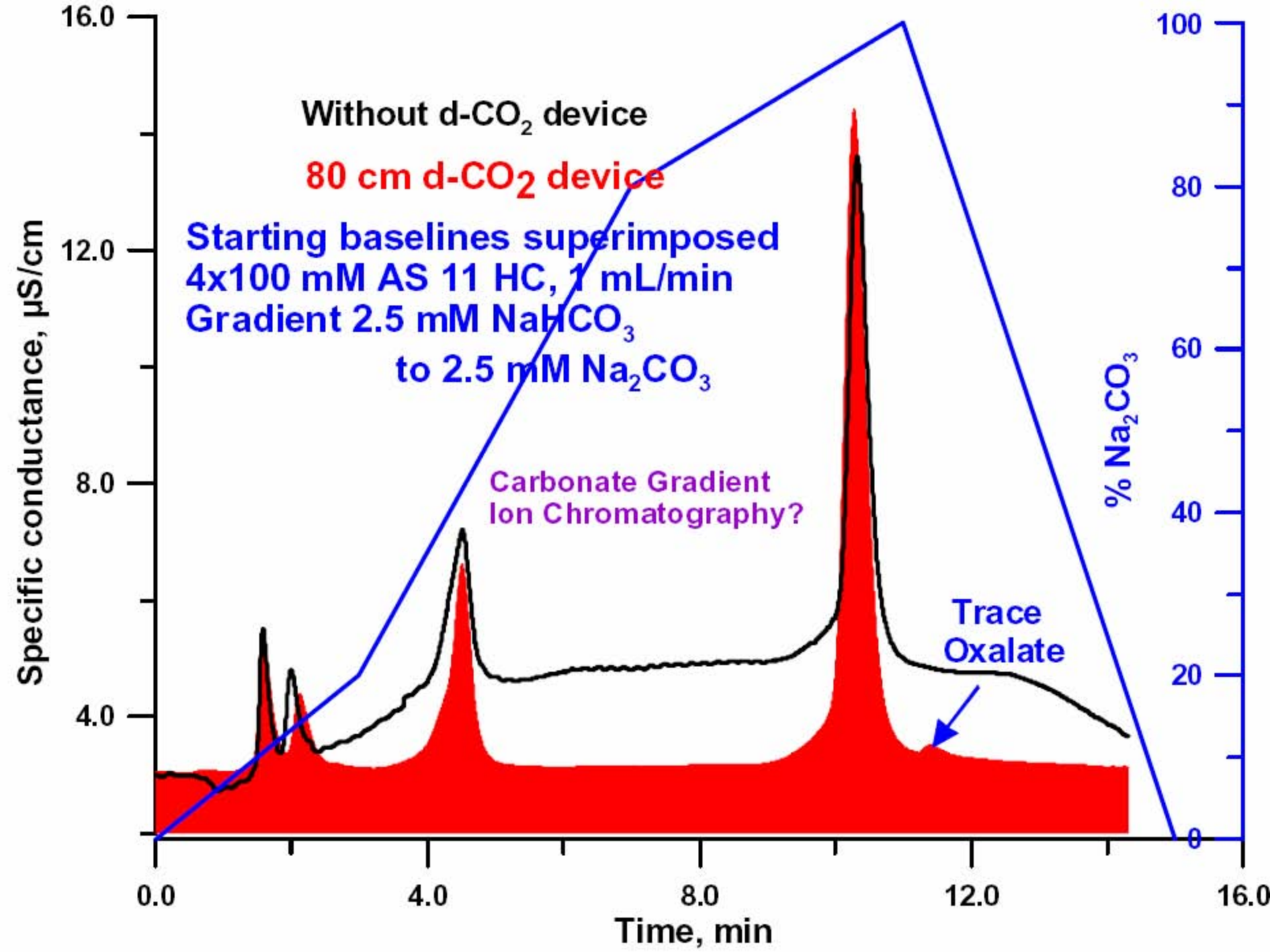

CRD Unit

Our Version,

**Asymmetric Membrane Fiber-Based Carbon Dioxide
Removal Devices for Ion Chromatography**

S. M. Rahmat Ullah, et al., DOI: [10.1021/ac0492160](https://doi.org/10.1021/ac0492160)

Won **Best Graduate Student Paper Award, ACS Division
of Environmental Chemistry**





This was commercialized. A patent was granted

Their Version
won a Pittcon Silver Award
And a IR-100 award

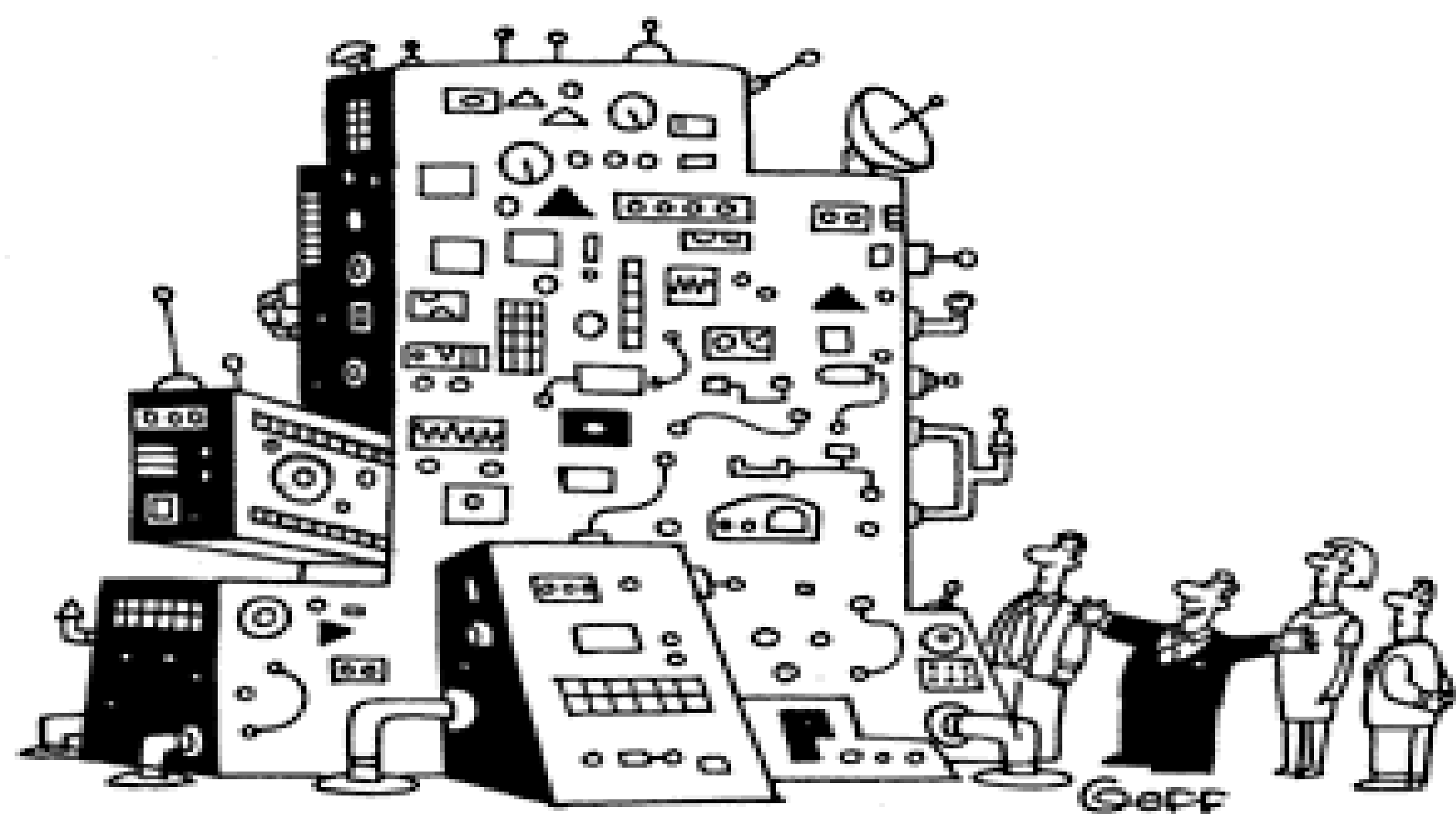

"Ladies and gentlemen, welcome to the future of the can opener!"

EPA STAR Project: EC OC LC - MS

Wavelength-discriminating Aethalometric Size-Discriminating Particle Sensor (WASPS)

Excellent correlation of EC with low wavelength aethalometry

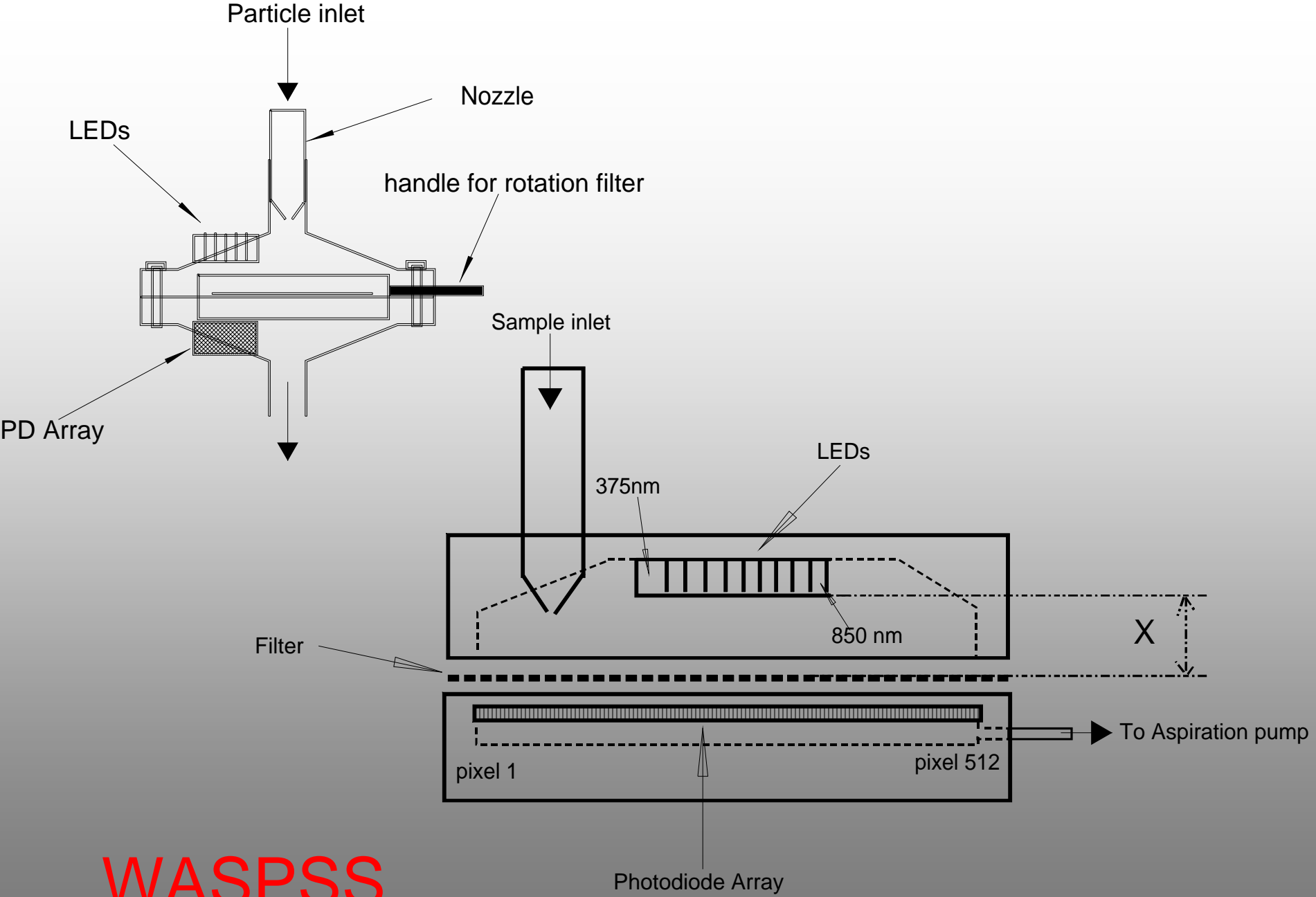

WASPSS

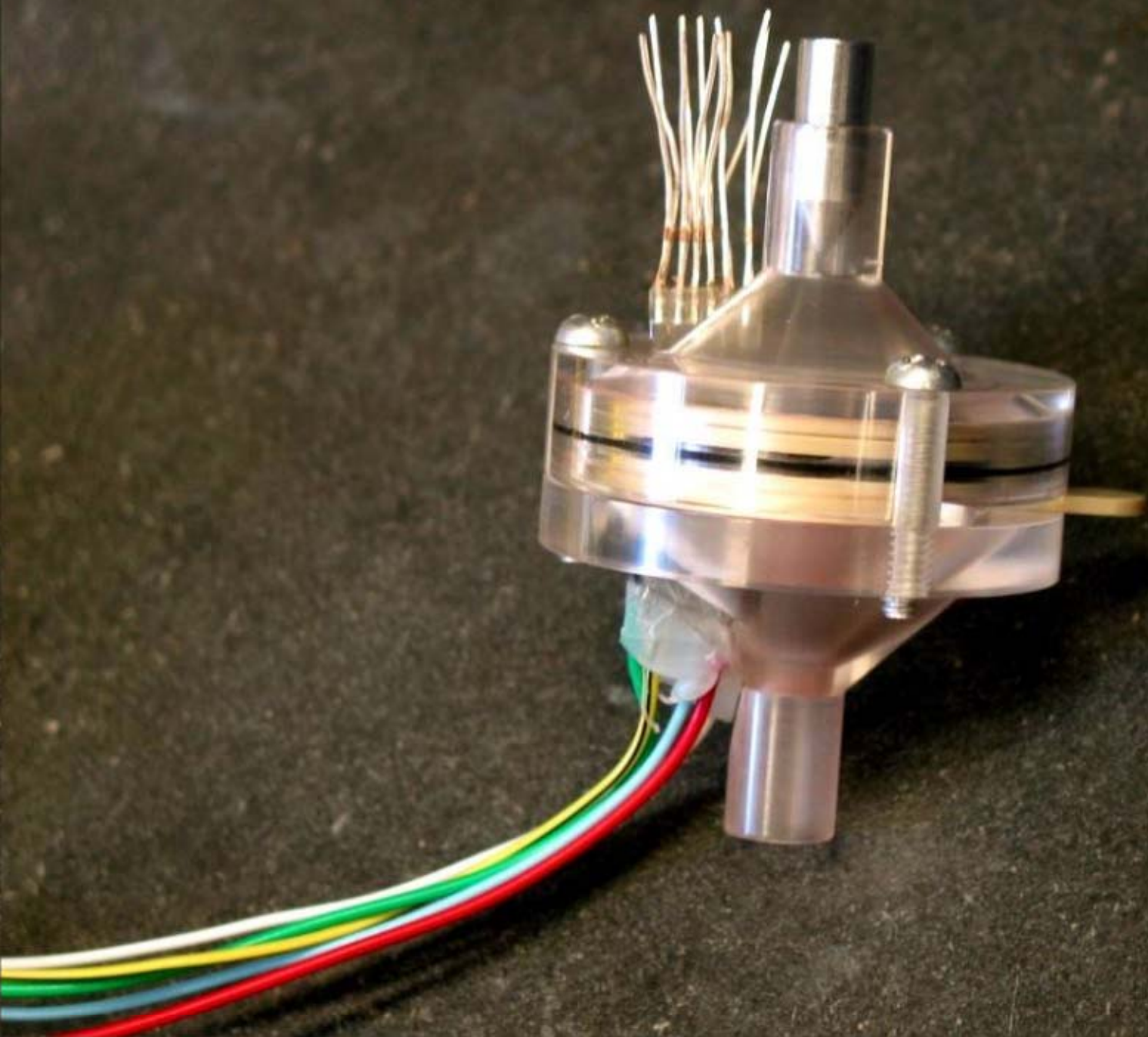

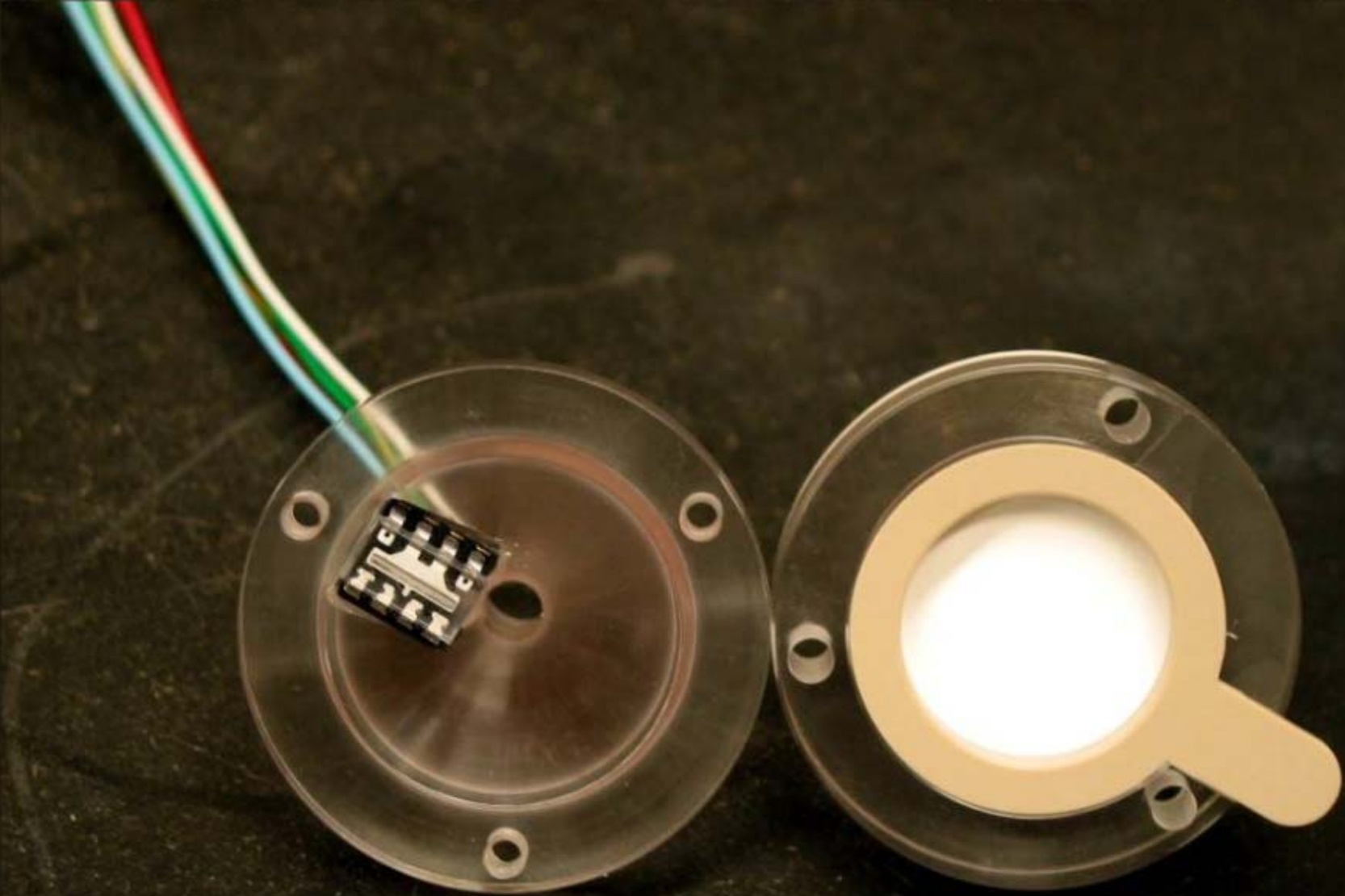

Factors affecting particle distribution patterns

- **Particle inlet tube size**
- **Sampling flow rate**
- **Distance between Nozzle and filter**
- **Particle size**

Air velocity at the nozzle 0.5 μm MMAD particles

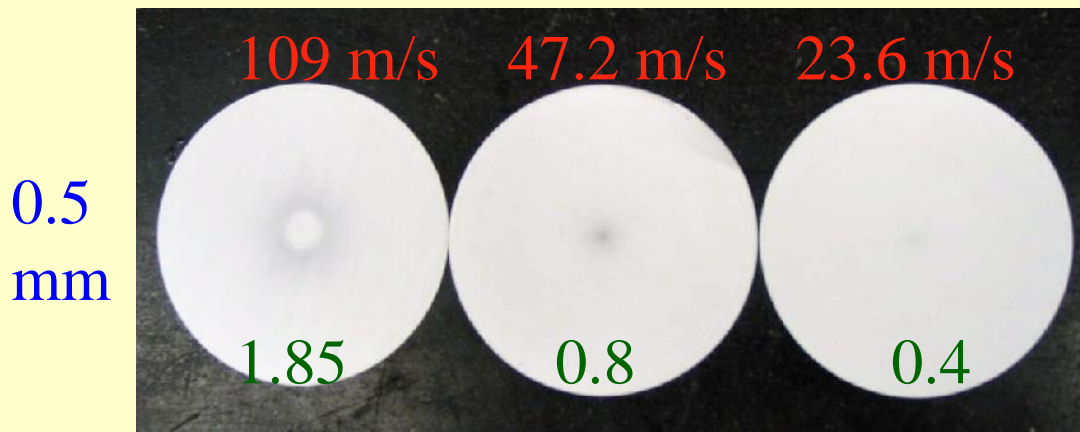
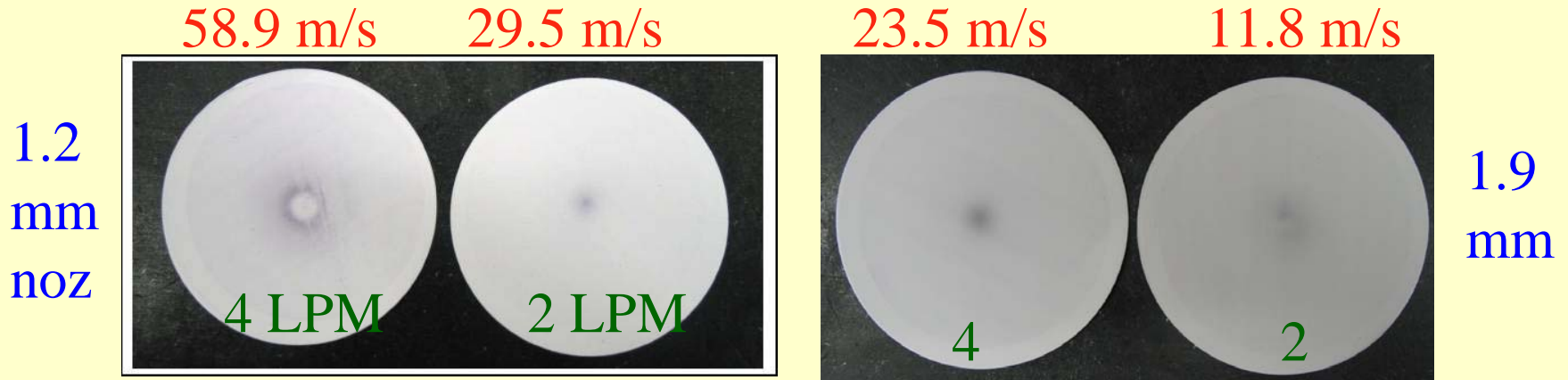

For 0.5 μm particles,
Nozzle velocity
should be controlled
between 10 to 50 m/s

Big particle distribution

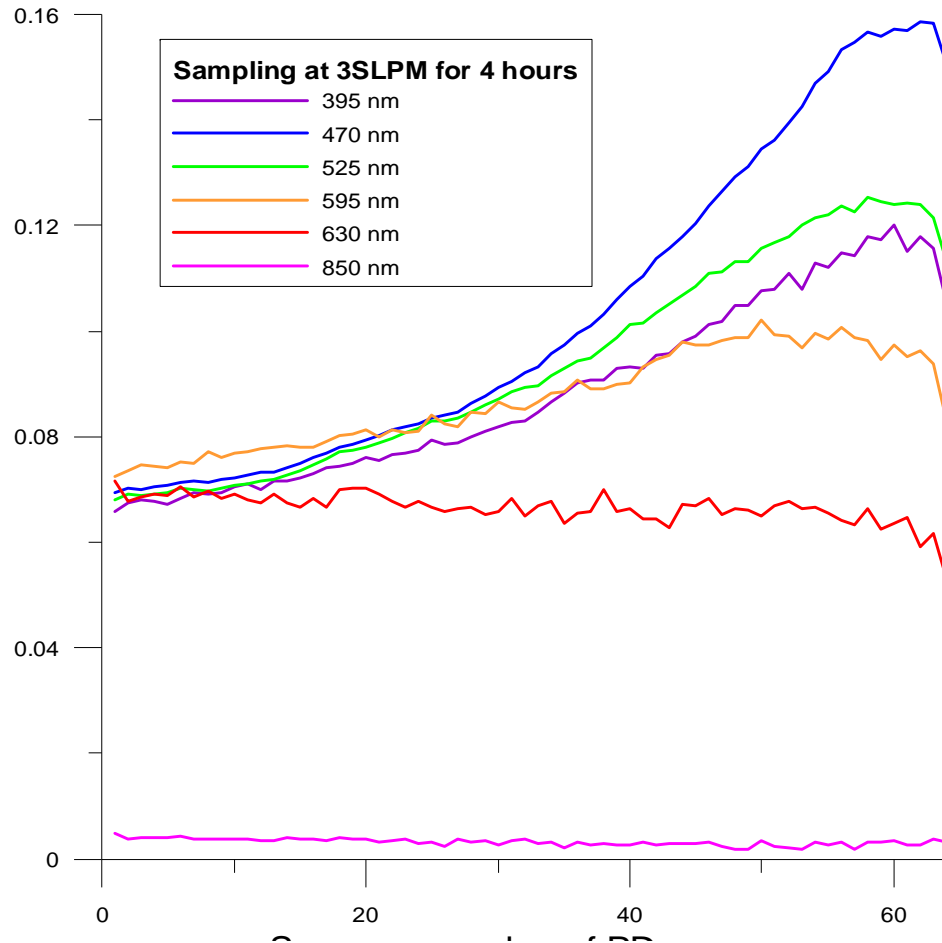

Medium Particle distribution

0.1-0.2 μm	0.2-0.3 μm	0.3-0.5 μm	0.5-1.0 μm	1.0-3.0 μm	>3 μm
31	16	11061	376	2	2

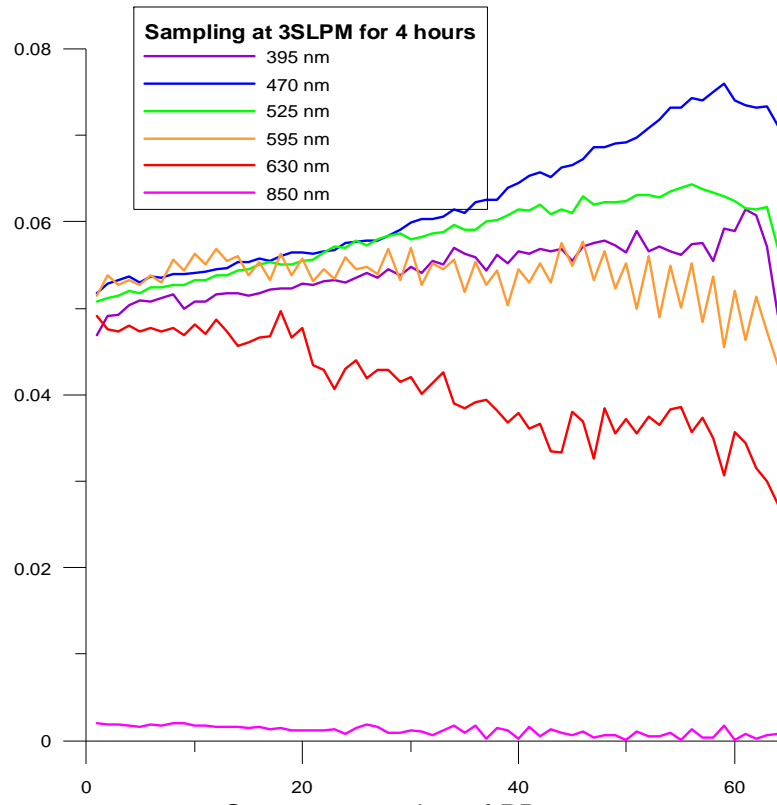

Small Particle distribution

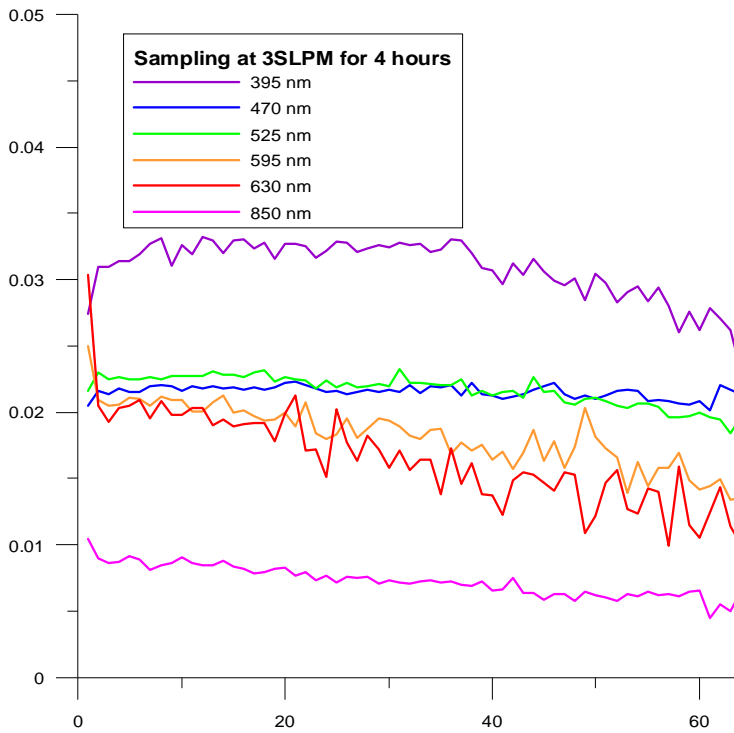

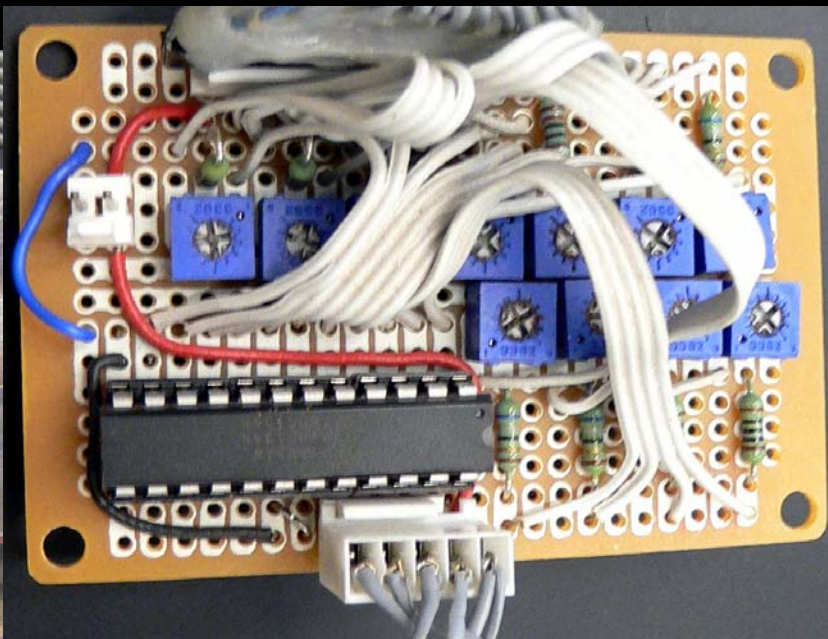
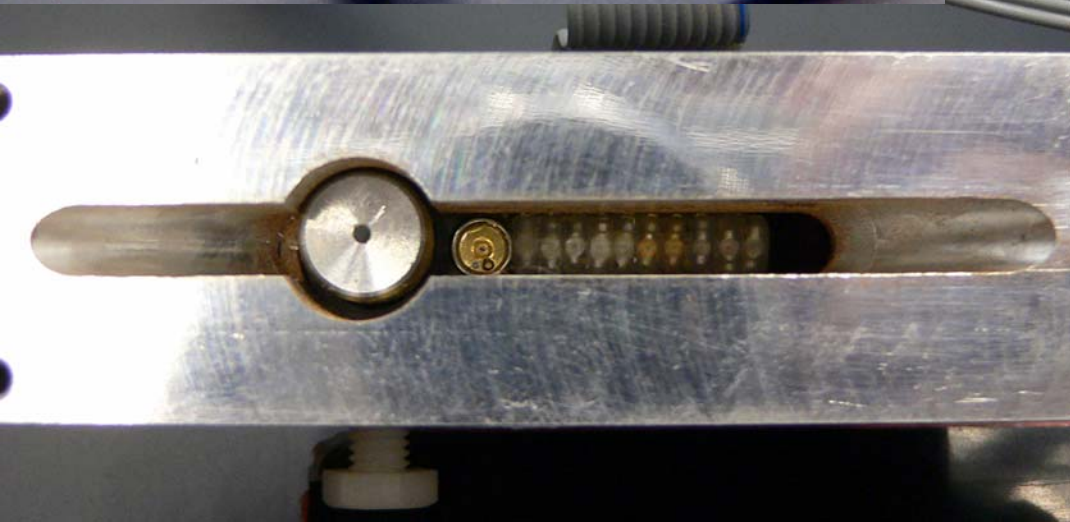
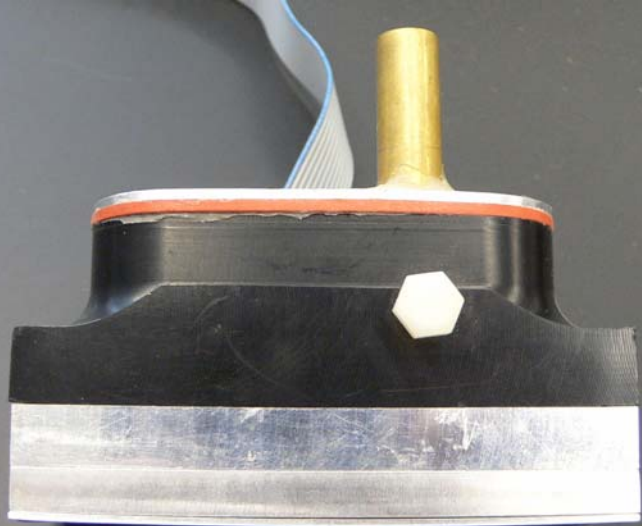

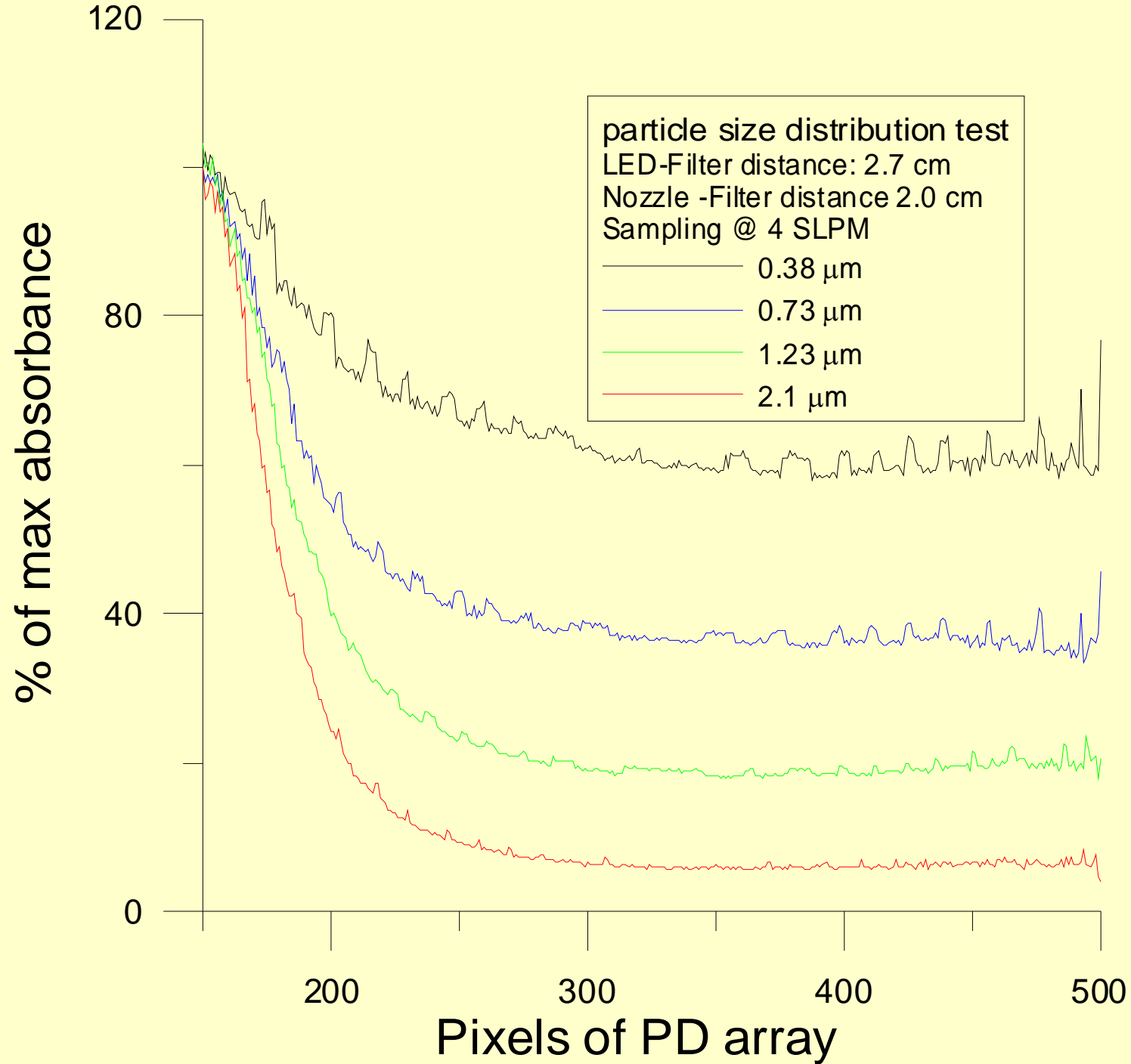

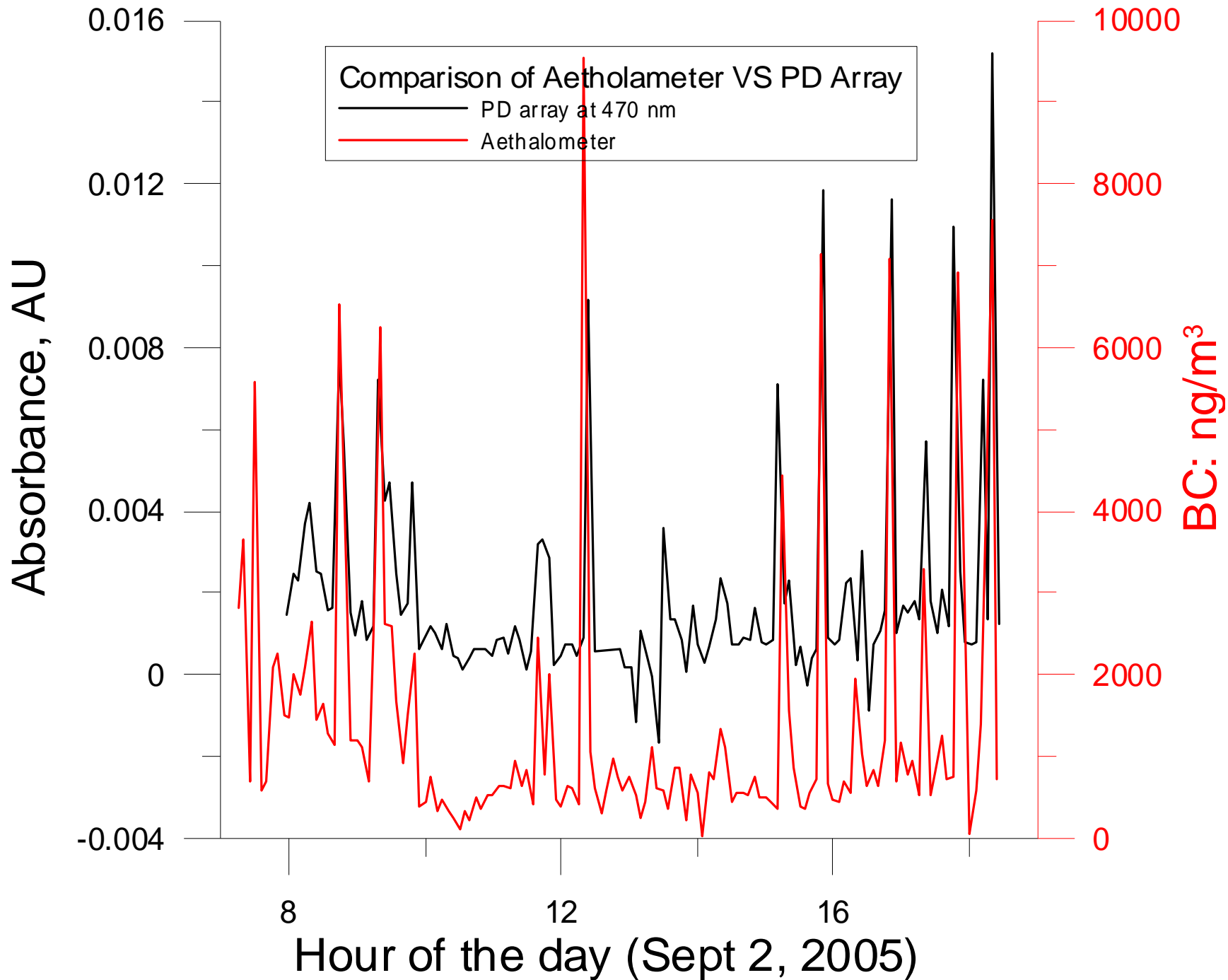

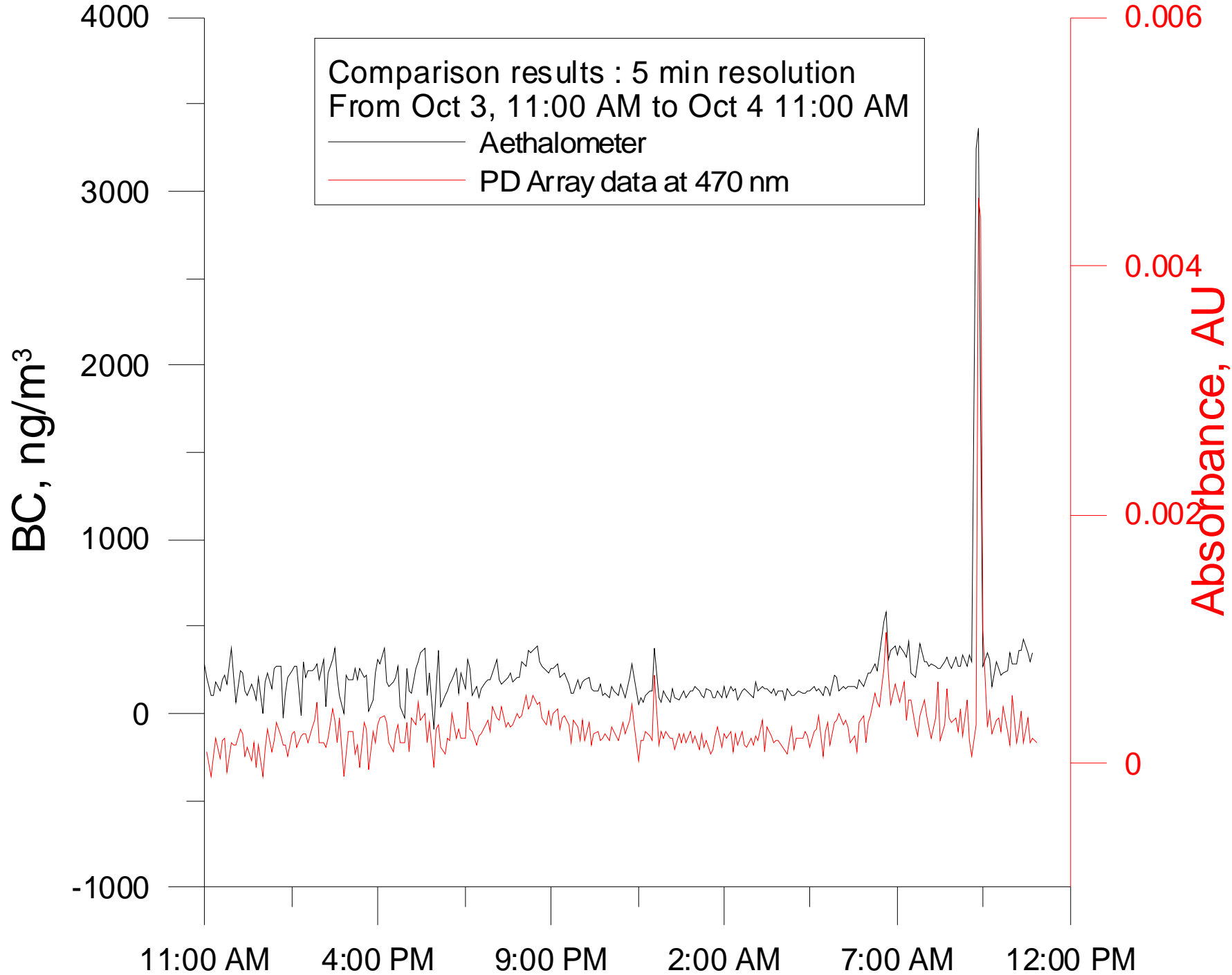

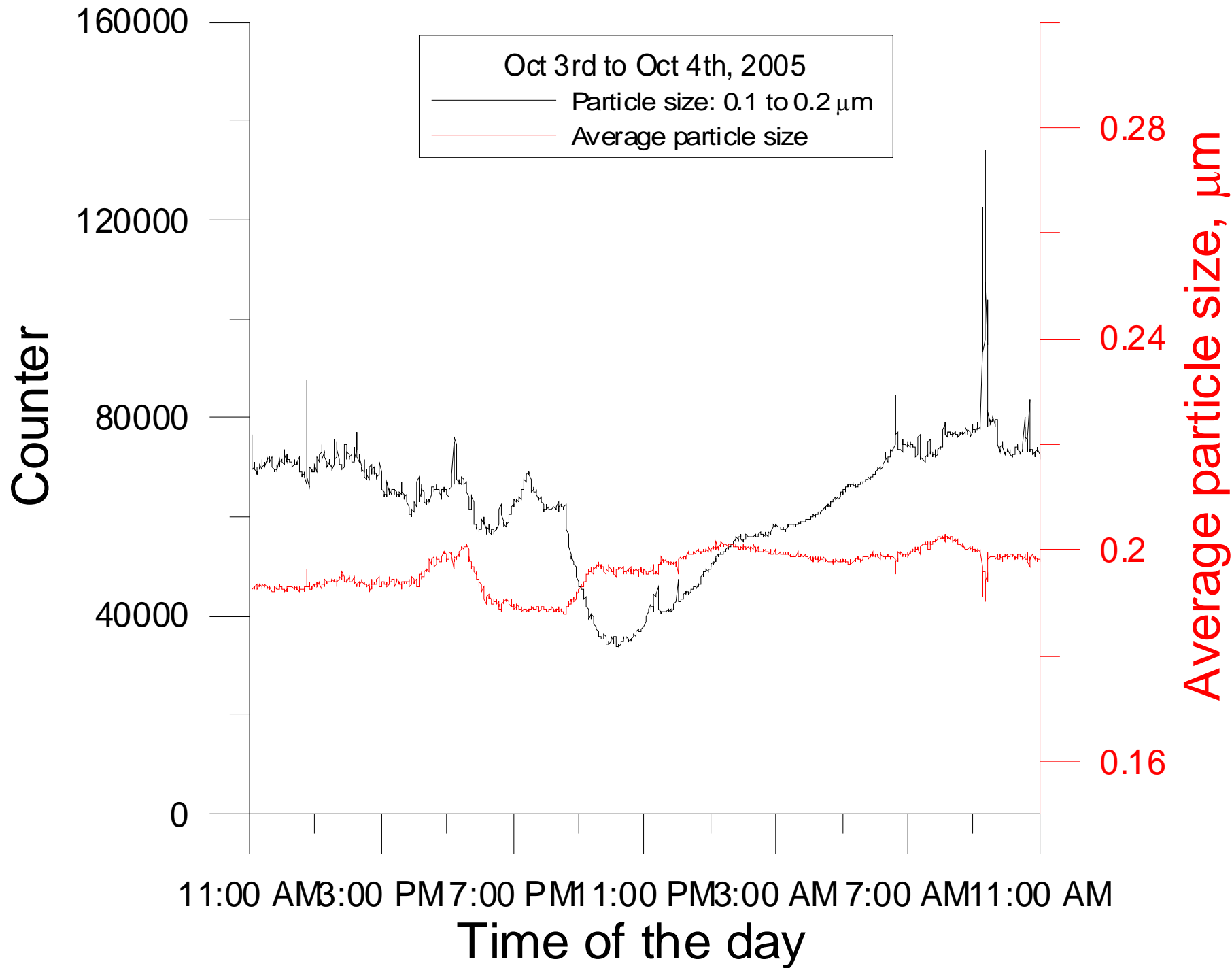

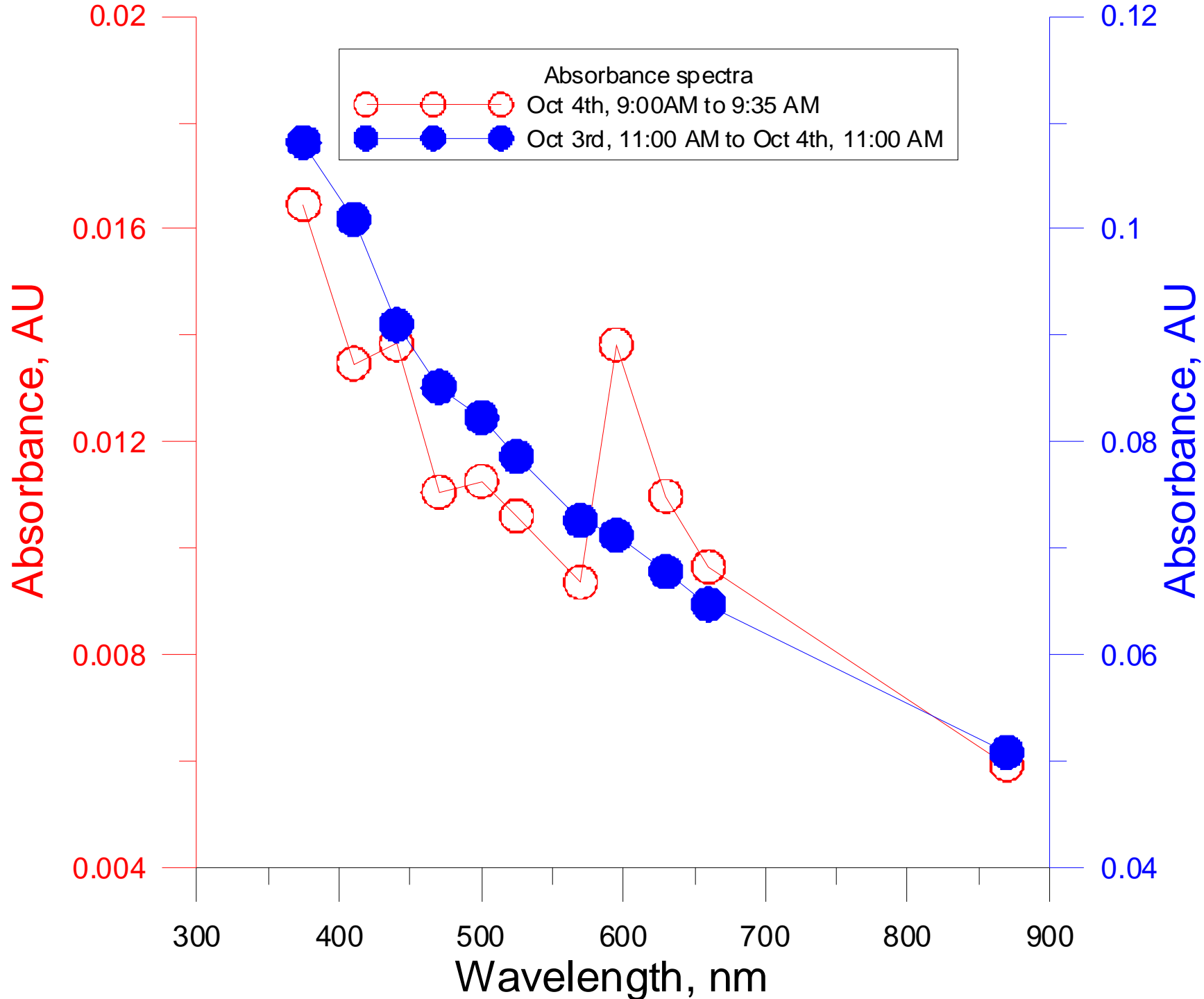

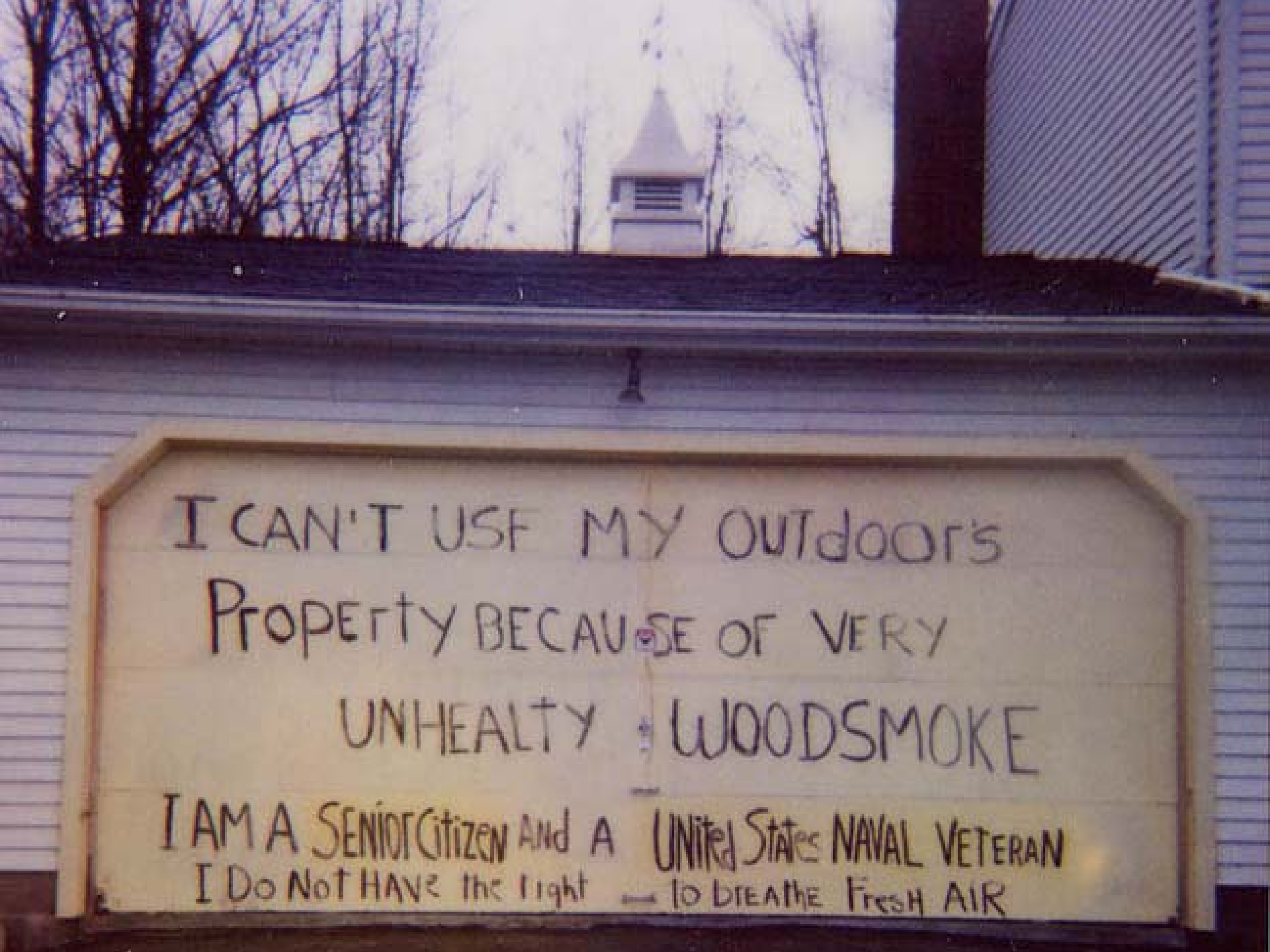

I CAN'T USE MY OUTDOOR'S
PROPERTY BECAUSE OF VERY
UNHEALTHY WOODSMOKE

I AM A SENIOR CITIZEN AND A UNITED STATES NAVAL VETERAN
I DO NOT HAVE THE RIGHT TO BREATHE FRESH AIR

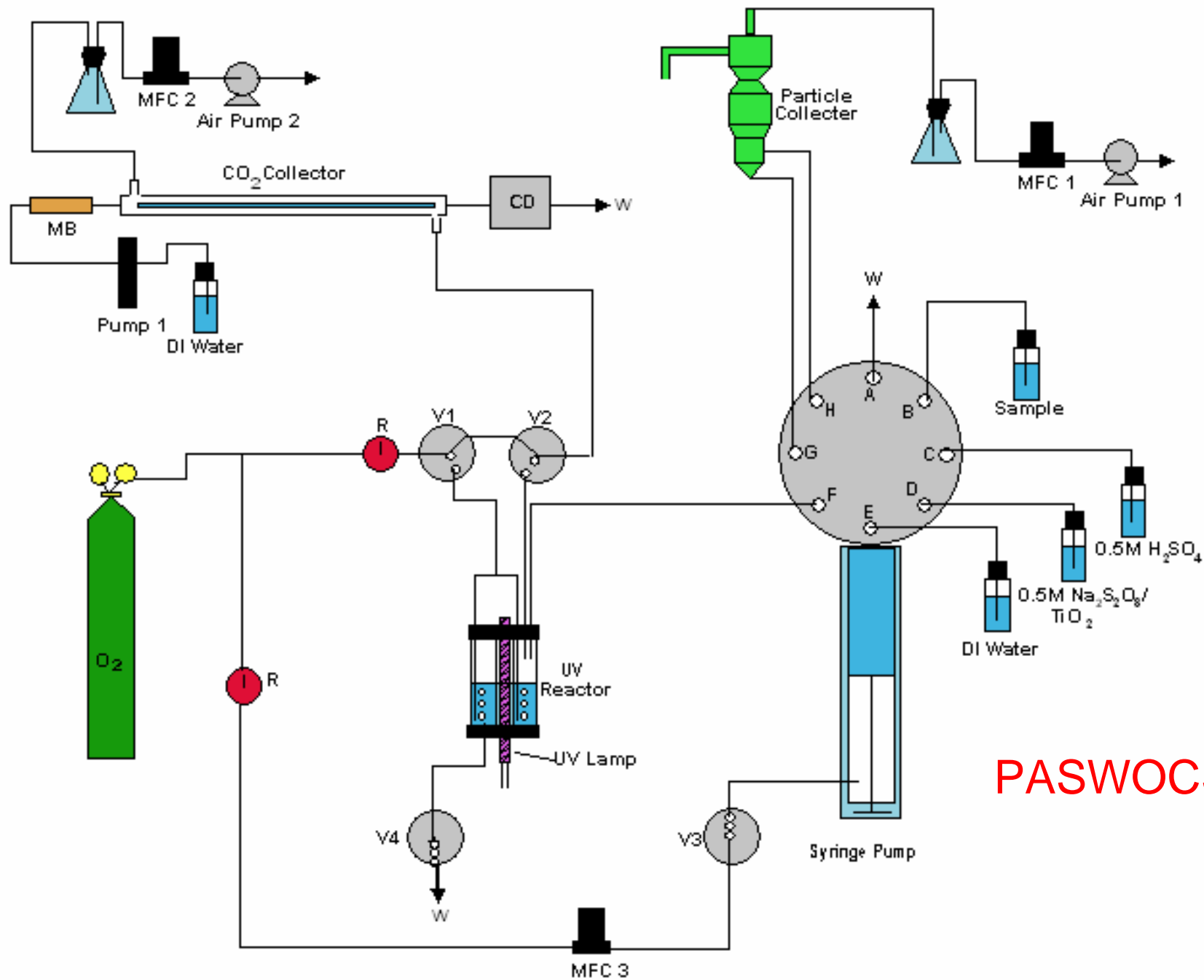

PASWOCS

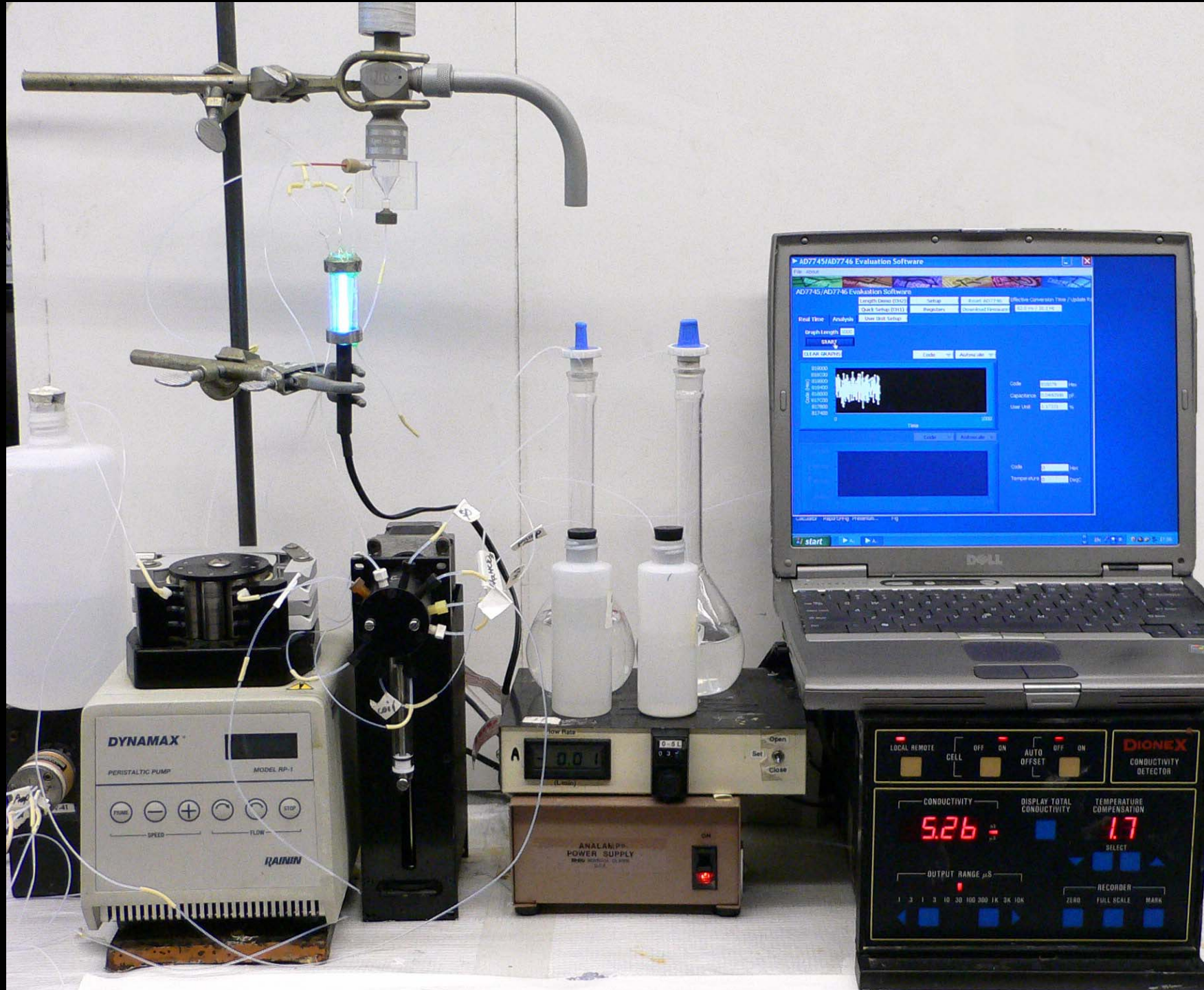

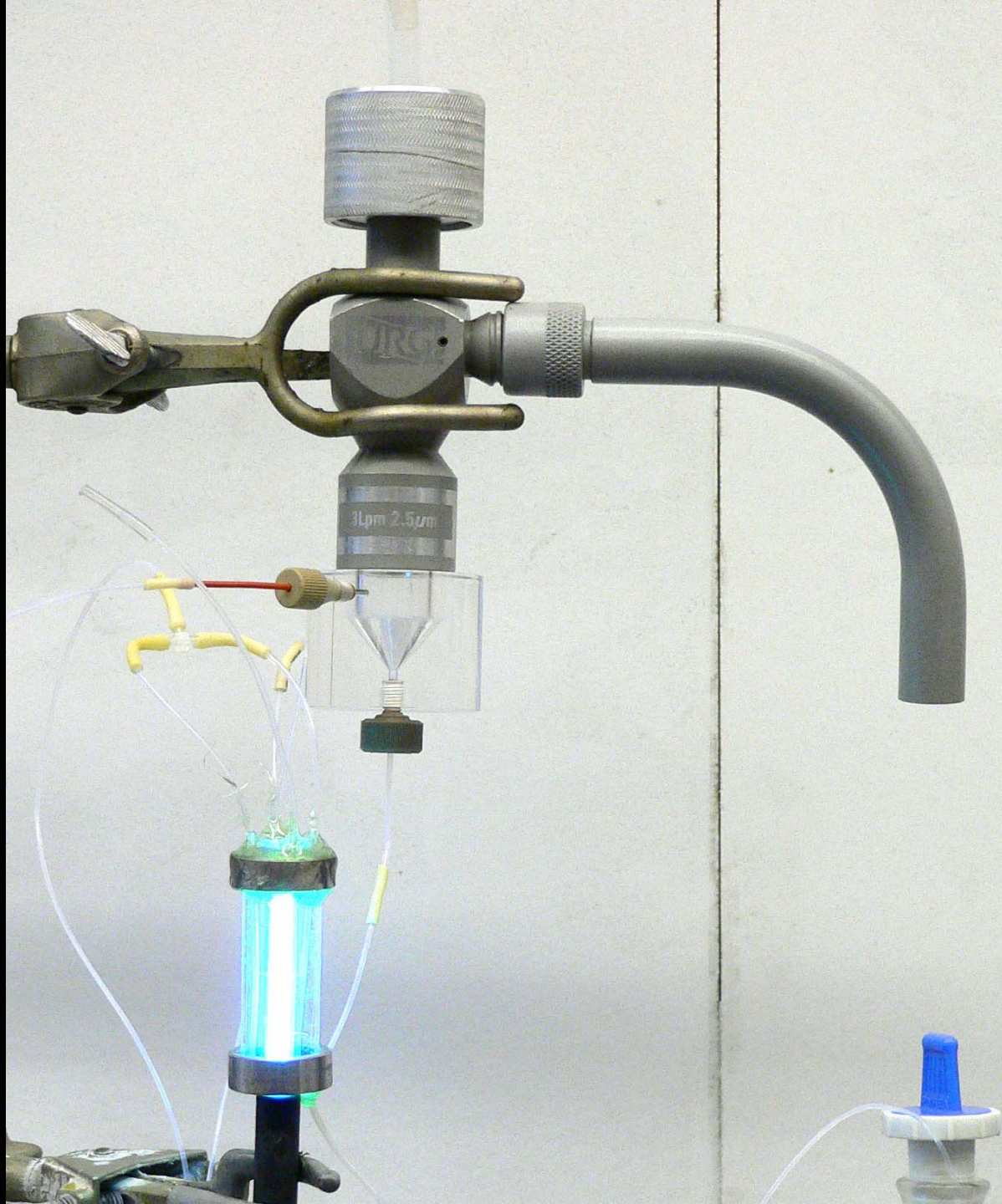

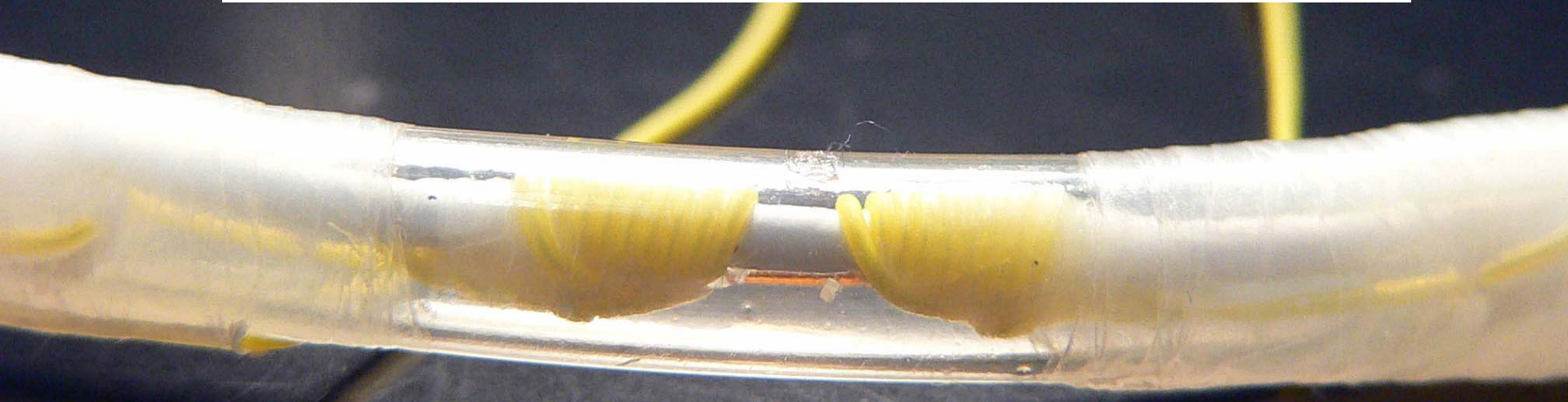
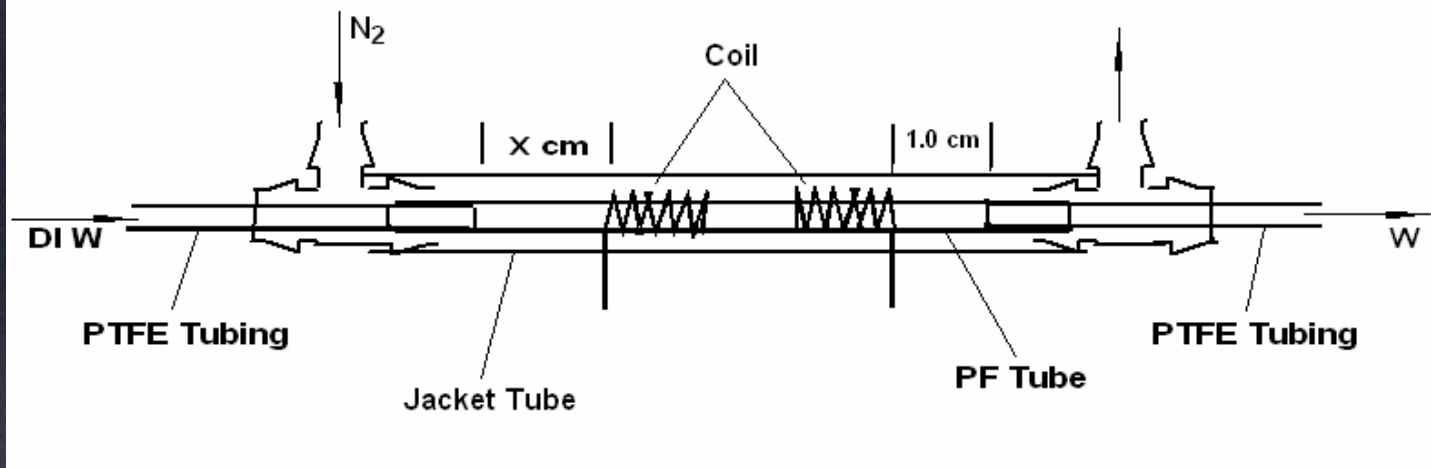

CO₂ Sensor

 **ANALOG
DEVICES**

AD7745/46 EVALUATION BOARD
WITH CAPACITIVE LENGTH SENSOR DEMO

E246366 J-1 AWA 94V-D 2505



**LOG
ICES**

EVAL-AD7745/46EB

 **ANALOG
DEVICES**

E246366

Rev. 43

AD7746



Absorber Considerations for CO₂ Sensor

DI water:

Low background; positive peak; easy to purify; no reagent; not linear.

LiOH Solution:

Linear to response; better absorbance; negative peak; high background.

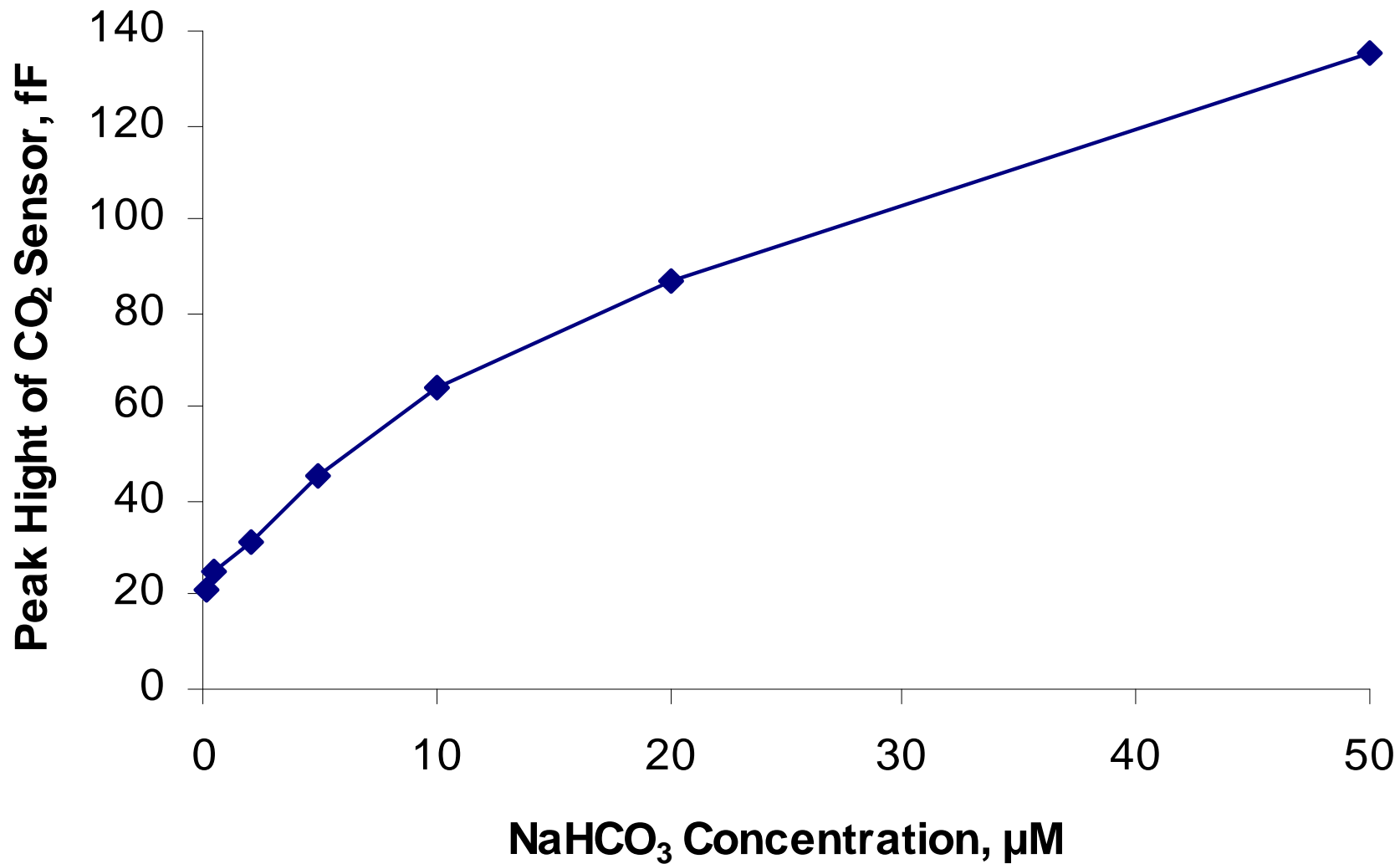

Methods for Degradation

- **Acidification and initial measurement of inorganic carbonate carbon**
- **UV Light**
- **TiO₂ (Catalyst)**
- **Na₂S₂O₈/Other Oxidations**

Influence of UV Lighting Time for Glucose Decomposition

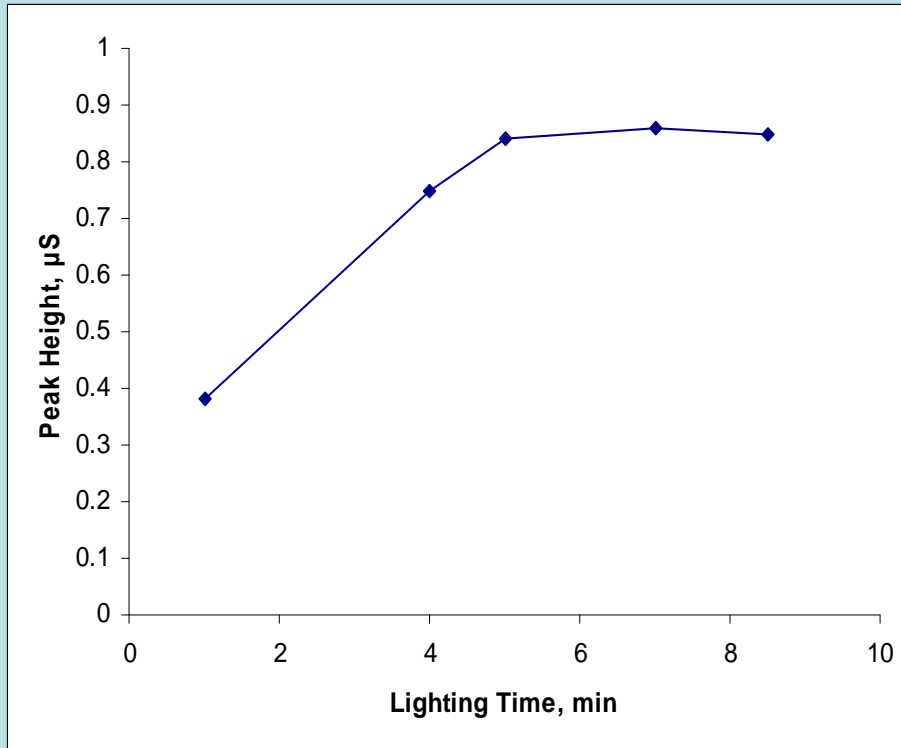

Glucose and most other simple sugars can be completely oxidized in 5 min using just UV light.

Cellulose

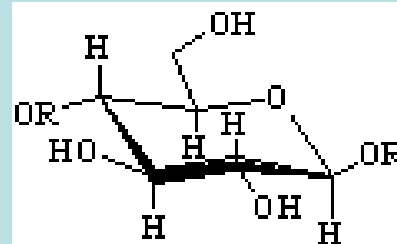

Levoglucosan

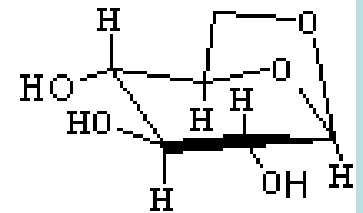

Levoglucosan, a common component of wood smoke, goes similarly

UV Reflectivity of Different Materials

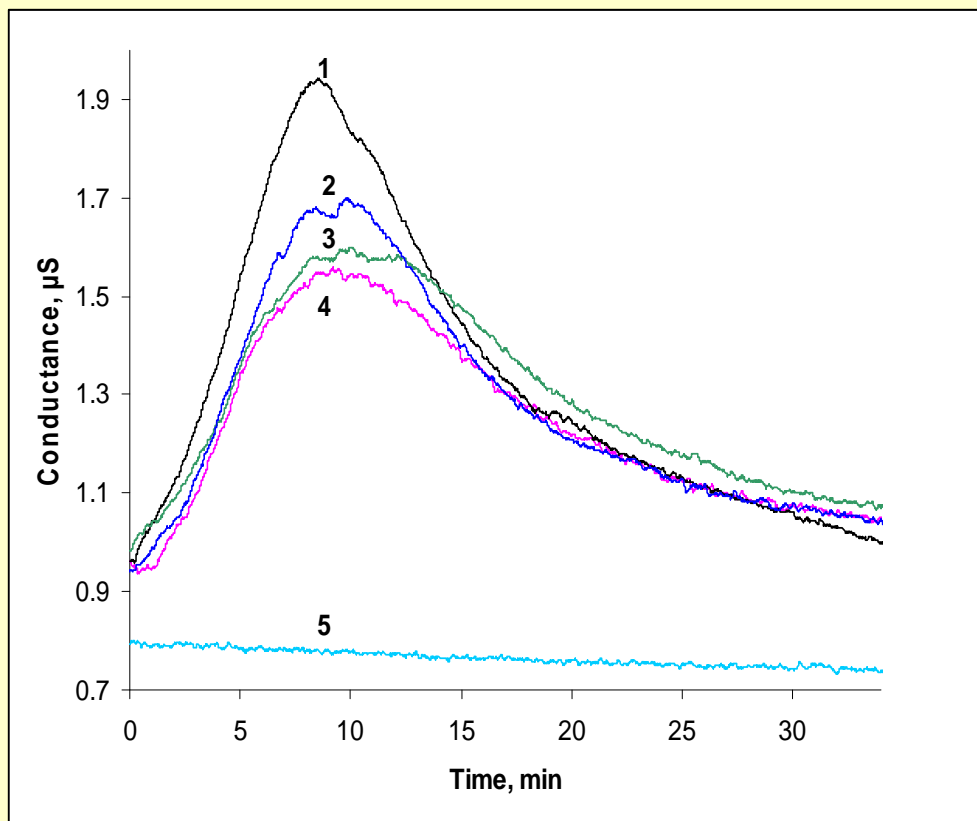

➔ Teflon tape has the best reflective ability for VU light.

1. Teflon tape; 2. Teflon tube; 3. Aluminum foil; 4. no covering; 5. no UV. Sample used: 0.8 mM Glu. Keep carrier gas continually pass through the reactor.

Aromatics: Oxidative Ability Test of TiO_2 and $\text{Na}_2\text{S}_2\text{O}_8$ for KHP

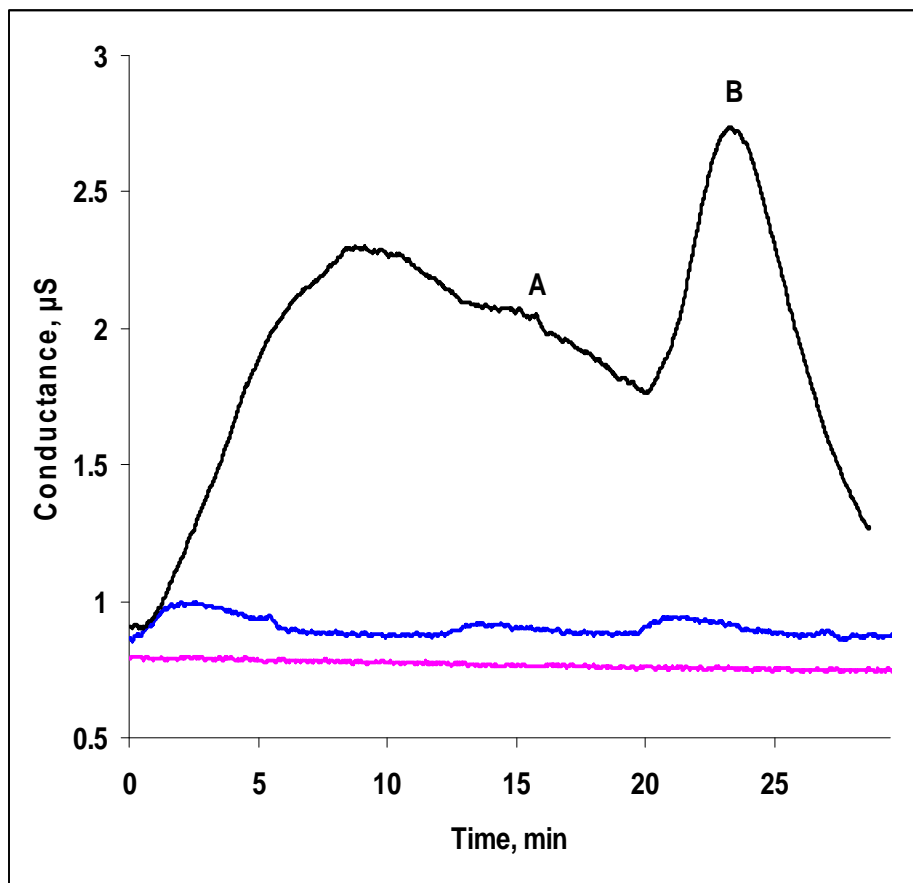

→ • TiO_2 + UV cannot rapidly oxidize KHP under present condition.

→ • $\text{S}_2\text{O}_8^{2-}$ has potential to decompose KHP rapidly.

Purple: DI W with no UV, TiO_2 , and $\text{Na}_2\text{S}_2\text{O}_8$; Blue: DI W with UV, TiO_2 , and $\text{Na}_2\text{S}_2\text{O}_8$; Black: KHP with UV, TiO_2 , and $\text{Na}_2\text{S}_2\text{O}_8$. A: TiO_2 Peak; B: $\text{Na}_2\text{S}_2\text{O}_8$ peak.

ACKNOWLEDGMENTS



This research is funded by

**U.S. EPA - Science To Achieve
Results (STAR) Program**

Grant # **RD- 83107401-0**