

THE STRENGTH-DURATION RELATION OF THE NORMAL, POLARIZED AND NARCOTIZED NERVE FIBER

ICHIJI TASAKI

From the Physiological Institute, Keio University, Yotsuya, Tokyo

Received for publication October 20, 1938

Since Lapicque (1906, 1926), Lucas (1907) and others published their historical experiments on the relation between the strength and the duration of the current necessary to excite a tissue, much work has been done by many investigators in tracing this relation in nerve or muscle. There has been, however, a wide divergence in detail of the various sets of experimental data obtained. This divergence seems to attest immediately the complexity of the excitable tissues.

A nerve, for example, is comprised of hundreds of nerve fibers with different irritability and, furthermore, these fibers are surrounded by a thick layer of connective tissue. When a constant current pulse is applied between two points on such a nerve trunk, the shape of the current pulse is known to be distorted by the polarization of non-excitabile tissues (Bishop, 1928). Further, the polarization resistance of these surrounding tissues presumably changes the distribution of potential along the nerve fiber inside. It therefore seemed worth while to investigate this problem in detail by the use of *isolated single nerve fibers*, which is obviously one of the simplest forms of excitable tissues.

In previous papers (1936, 1938a) I have shown that, in the medullated nerve fiber, complete desiccation of the medullated region alone does not inflict upon the fiber any noticeable change in excitability or conductivity if all the nodes of the fiber are kept in Ringer's solution. This property of the nerve fiber was utilized first for demonstrating that narcotics affect the nerve fiber only at the nodes of Ranvier (Tasaki, 1936, 1938a). But later I noticed that the same "micro-technique" can be used with several important advantages for stimulation of the nerve fiber.

The principle of the technique consists in insulating a nerve fiber between two neighboring nodes of Ranvier by desiccating the internodal region on glass capillaries (which I call a "ridge-insulator") and immersing electrodes in each pool of Ringer on both sides of the insulated region (see figs. 2 and 3). When this type of special fluid electrodes is used, the resistance of the electrode circuit becomes always well over one megohm; hence there will obviously be no deformation of the stimulating current by

polarization at the electrodes or at the connective-tissue sheath. And, since the two pools of Ringer's solution on both sides of the ridge-insulator can be treated as being equipotential surfaces, the distribution of potential along the fiber is quite simple and known.

The experiments described in this paper were undertaken with a view to providing for the problem of electric excitation of nerve new data obtained under these extremely simple experimental conditions. The effect of narcosis and electrotonus upon the strength-duration ($V-t$) relation of the nerve fiber was also investigated in this connection. Further, the difference between the new data and those obtained with the usual nerve trunk is discussed with special reference to the effect of the connective-tissue sheath surrounding the nerve trunk.

METHODS. The following method of preparation of a single motor fiber is based upon the earlier methods of Adrian and Bronk (1928) and of Shimizu (see Kato, 1934). It embodies improvements introduced by Z. Kaku (unpublished) and other members of this Institute.

A nerve-muscle (e.g., sciatic-gastrocnemius) preparation of a toad or a frog is laid on the glass platform of a wooden experimental table. In the gastrocnemius, there are three (sometimes two) branches of nerve which enter the muscle from the tibial nerve. One of the branches, preferably the distal or the middle one, is left after severing the others with small scissors (fig. 1, A). Then, the blood-vessels and connective tissue around the nerve trunk are cautiously removed with needles (the region in the circle, fig. 1, A).

In the subsequent operations, only a pair of sharp (or, at some stages, blunt) needles are used for the operation. Needles, sharpened on a whetstone and fixed rigidly to the holders, can be used conveniently for cutting, teasing or separating the connective tissue or the nerve fibers. Strong pressure applied rhythmically under the tip of the sharp needle cuts these tissues more easily than a sharp scalpel.

When the cleaning is accomplished (fig. 1, B), the connective-tissue sheath which surrounds the nerve is split with sharp needles (C). In order to avoid cutting the motor fibers, it is necessary to pull the tibial nerve lightly in the direction marked by the arrows in the figure. The active fibers which run through the muscle-nerve are carefully separated with needles from the remaining inactive fibers (C and D), and this procedure is continued step by step until only the fibers connecting with the muscle are left undivided (E). The sheath is pulled out on one side and is cut across (F). The operated region is then cleaned by removing pieces of connective tissue and most of the damaged fibers. Up to this point it is possible, with practice, to operate without injuring any motor fiber, that is, without producing twitches in the muscle during operation.

The exposed nerve bundle is then split with more or less blunt needles in such a way as to leave in the middle intact nerve fibers separated distinctly from one another (fig. 2, G and H). Then the lateral strands are cut across. Care should be taken at this stage in the operation to keep the amount of Ringer's solution around the operated region as scant as possible (but not dry!), otherwise the separated fibers will group closely again and this makes the subsequent dissection quite difficult.

When the intact fibers are widely separated from one another, a small Zn-Cu couple (Kato, 1934, p. 7) is used to identify the active motor fibers, and then all the fibers are cut across except a single fiber which produces muscular twitches when

stimulated with the Zn-Cu couple (I and J). In the small nerve twig which enters the muscle, most of the large fibers are motor fibers which innervate the muscle. A rough estimation of fiber sizes with a microscope is therefore very helpful (especially for beginners) in selecting motor fibers.

In the present investigation, the sciatic-adductor magnus (caput accessorius), sciatic-gastrocnemius or sciatic-sartorius preparation of the Japanese toad (*Bufo vulgaris*) was used. When a nerve fiber with long (over 2 mm.) internodal distances was successfully isolated, the preparation was soaked in Ringer's solution for 3 to 6 hours prior to the measurement. In all cases the composition of the Ringer used was 6.5 grams NaCl, 0.14 gram KCl, 0.12 gram CaCl₂, 0.2 gram NaHCO₃, 0.01 gram NaH₂PO₄ and 2.0 grams glucose made to 1 liter with distilled water.

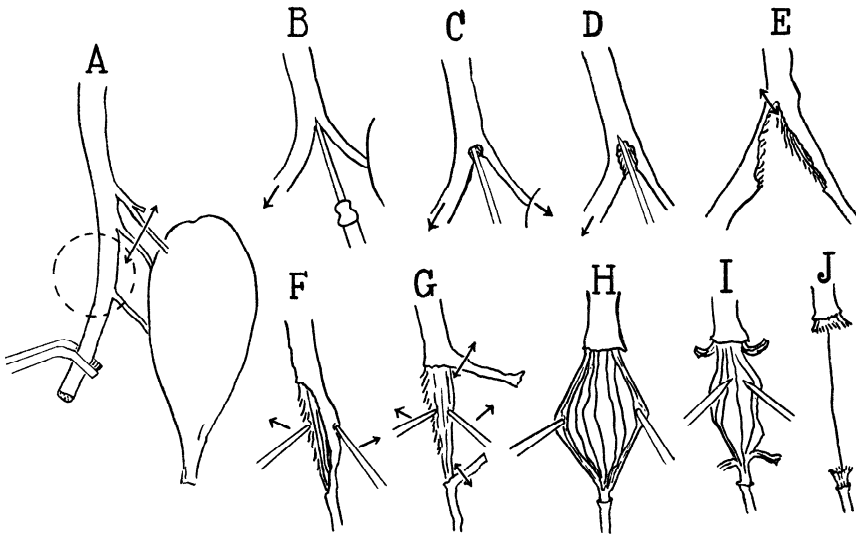

Fig. 1. Procedure of the operation to isolate a single nerve fiber from a sciatic-gastrocnemius preparation of a toad or a frog.

Then the preparation was mounted on a glass-plate with a pair of ridges ("ridge-insulator"), and the internodal region of the fiber was desiccated on the ridges (figs. 2 and 3).

A "ridge-insulator" is made of two pieces of glass capillary, both about 0.25 mm. in diameter and slightly bent, fixed tightly on a glass plate with shellac at a distance of about 0.4 mm. The upper surface of the capillary is coated smoothly with paraffin to prevent adhesion of the fluid. The space on the glass plate is filled with Ringer's solution and the preparation is floated in this pool of Ringer. A salt bridge (a glass tube filled with Ringer-agar) is placed across the ridges. The preparation in the pool of Ringer is moved under a low-power microscope so that no node of Ranvier of the nerve fiber lies between or on the ridges (fig. 2).

Then the Ringer's solution between the ridges is cautiously removed with a small

brush until the space between the ridges is completely dry. A pair of electrodes, connected together by a resistance, are immersed in the pools of Ringer, one on each side of the ridges and the salt bridge is removed. The salt bridge is to short-circuit the insulated region in order to prevent violent tetanic contractions of the muscle which are frequently caused by weak accidental currents. A preparation thus mounted on the ridges can be used for threshold determination with constant rheobase and chronaxie for over 5 hours. The electric resistance across the ridges rises, up to a few megohms at least when the fluid between the ridges is completely removed.

Non-polarizable electrodes of Zn-ZnSO₄-Ringer type or Ag-AgCl-Ringer type were dipped in the pools of Ringer's solution on each side of the

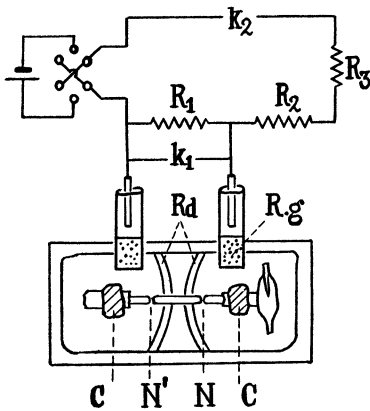

Fig. 2

Fig. 2. Arrangement used for determination of the $V-t$ relation in the isolated nerve fiber. R 's: resistances. k 's: contacts of Helmholtz pendulum. $R.g$: Ringer-gelatin. Rd : ridges made of glass capillary. N and N' : nodes of Ranvier. C : cotton wool soaked in Ringer's fluid.

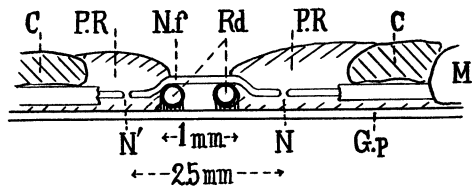

Fig. 3

Fig. 3. Diagram illustrating desiccation of the internodal region of a nerve fiber on a "ridge-insulator." M : muscle. $G.p$: glass plate. $P.R$: pool of Ringer. Other symbols have the same meanings as in figure 3.

ridges, and the nerve fiber was excited with rectangular current pulses supplied by the circuit shown in figure 2, top. Keys k_1 and k_2 were operated by a Helmholtz pendulum (Edelmann). One division of the scale was equivalent to 0.215 msec. The variation of the zero point of the pendulum during the course of an experiment was usually less than 0.004 msec. The resistance in the potential-divider circuit was relatively low. The variable resistances R_1 and R_2 were changed in such a way that the sum ($R_1 + R_2$) was always equal to 2,000 ohms. The resistance R_3 was adjusted prior to each experiment so that a current of 0.5 milli-ampere flowed in the battery circuit when key k_2 was closed. The reading of the resistance R_1 therefore gave twice the strength expressed in millivolts.

A muscle twitch of strictly all-or-none character, observed by eye, was taken as the index of nerve excitation. The pause between each trial (stimulation) was held constant in one experiment and was 20 or 30 seconds in most cases. For the narcotized nerve fiber, an interval of about 10 seconds was adopted.

When the effect of electrotonus was to be investigated, the circuit shown in figure 4 was used. In the polarizing circuit, there was no knock-down key. The polarizing current was allowed to act continuously upon the nerve fiber. With this special type of fluid electrodes, the threshold was found to reach a steady level soon after application of continuous direct current.

In the investigation of the effect of narcosis, isolated nerve fibers as long as 8 mm. or more were used. At least two nodes of Ranvier were exposed in the pool of Ringer on the distal side of the ridges. The fluid in the pools (fig. 2) was replaced with a narcotizing solution (cocaine or

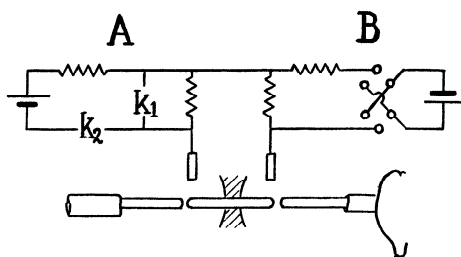

Fig. 4. Arrangement to determine the $V-t$ relation in the polarized nerve fiber. A: exciting circuit. B: polarizing circuit.

urethane Ringer) and the threshold was determined. As I have pointed out (1936, 1938b; see also Kato's review, 1936), the change of irritability produced by the action of a narcotic upon the isolated nerve fiber is not progressive. A steady state is reached immediately after application of a narcotic of a given concentration. The determination of the $V-t$ relation therefore could be done much more easily on single-fiber preparations than on nerve-trunk preparations.

Most of the experiments were performed during winter months, from January 1937 to February 1938. The temperature was generally between 10° and 15°C.

RESULTS. *I. Normal nerve fiber. A. Descending current.* Table 1 shows typical data of the $V-t$ relation for descending constant current pulses. The symbol "35.5-36" in the second column of the table means that at 35.5 millivolts the stimulation was ineffective and at 36.0 millivolts, when tried after the usual pause of 30 seconds, the muscle showed a twitch.

The threshold is constant and the experiment is consistently repeatable. In favorable cases the variation in the liminal voltage for the duration of 5 msec. is less than 1 to 2 per cent for over 2 hours.

TABLE 1

The strength-duration relation in a toad's nerve fiber (see table 4, no. 4 and fig. 1)

DURATION	STRENGTH ↓	STRENGTH ↑	$V = 12.7/t + 34.8$
<i>msec.</i>	<i>millivolts</i>	<i>millivolts</i>	
∞		35.25-35.5	34.8
5.000	35.5-36.0	35.5 -35.75	37.3
0.1097	151 -152	150 -151	150.6
0.1634	112 -113	111 -112	112.5
0.2172	94.0-95.0	94.0 -95.0	93.3
0.3247	74.0-74.5	73.5 -74.0	73.9
0.4322	64.0-64.5	63.0 -63.5	64.2
0.5397	58.0-58.5	57.0 -57.5	58.3
5.000	36.0-36.5	35.5 -36.0	
0.647	54.0-54.5	54.0 -54.5	54.4
0.862	49.5-50.0	49.5 -50.0	49.6
1.077	46.5-47.0	47.0 -47.5	46.6
1.507	42.5-43.0	43.0 -43.5	43.3
2.152	40.5-41.0	42.0 -42.5	40.7
3.227	38.0-38.5	38.0 -38.5	38.7
5.000	36.0-36.5		

TABLE 2

The strength-duration relation in a toad's nerve fiber (see table 4, no. 7)

DURATION	STRENGTH ↓	STRENGTH ↑	$V = 18.5/t + 43.0$
<i>msec.</i>	<i>millivolts</i>	<i>millivolts</i>	
∞		38.5-39.0	43.0
5.000	44.0-44.5	43.5-44.0	46.7
0.1075	212 -213	214 -215	215.0
0.2150	127.5-128.5	131 -132	129.0
0.3225	98.0-99.0	101 -102	100.3
0.4300	87.0-88.0	86.0-87.0	86.0
5.000	43.5-44.0	44.0-44.5	
0.645	71.0-72.0	72.0-72.5	71.7
1.075	60.0-60.5	60.0-60.5	60.2
2.150	51.0-51.5	51.5-52.0	51.6
3.225	47.5-48.0	48.0-48.5	49.7
5.000	44.0-44.5		

In the last column, the values calculated by Weiss' formula

$$V = \frac{a}{t} + b$$

are given. It is evident that this old empirical formula (see Lapicque, 1926) describes the observed $V-t$ relation very closely. In figure 5, the

TABLE 3
The strength-duration relation in a toad's nerve fiber (see table 4, no. 1 and fig. 9)

DURATION	STRENGTH ↓	STRENGTH ↑	$V = 11.4/t + 26.0$
<i>msec.</i>	<i>millivolts</i>	<i>millivolts</i>	
∞		29.25-29.5	26.0
10.000	29.5-30.0	29.25-29.5	27.2
4.300	30.0-30.5	30.0 -30.25	28.7
3.010	30.5-31.0	30.5 -31.0	29.8
2.150	31.0-31.5	31.5 -32.0	31.3
1.505	33.5-34.0	33.5 -34.0	33.6
10.000	29.5-30.0	29.5 -30.0	
1.075	36.5-37.0	36.5 -37.0	36.6
0.860	39.5-40.0	39.0 -39.5	39.3
0.645	44.0-44.5	44.0 -44.5	43.7
10.000	29.0-29.5	29.5 -30.0	
0.537	47.0-47.5	47.0 -47.5	47.2
0.431	52.5-53.0	52.0 -52.5	52.5
0.322	61.0-61.5	60.0 -61.0	61.3
10.000	29.5-30.0	29.0 -29.5	
0.215	78.0-79.0	77.0 -78.0	79.0
0.161	96.0-97.0	96.0 -97.0	96.8
0.107	132.0-133.0	133.0 -134.0	132.5
0.052	252.5-255.0	250.0 -252.5	245.2
10.000	29.0-29.5		

TABLE 4
Summary of the results obtained between December 14th, 1937 and January 30th, 1938

EXPERIMENT NUMBER	PREPARATION (SCIATIC-)	a/b	b	CONTROL $t-V$	TEMPERATURE	PAUSE BETWEEN STIMULI	INTER-NODAL DISTANCE
		<i>msec.</i>	<i>mV</i>		$^{\circ}\text{C.}$	<i>sec.</i>	<i>mm.</i>
1	adduc. mag.	0.45	26.0	10-29.5	13.2	ca. 10	2.78
2	sartorius	0.39	29.5	10-30	13.3	20	2.08
3	adduc. mag.	0.41	49.5	10-46	14.8	20	2.38
4	sartorius	0.37	34.8	5-36	8.8	30	2.05
5	gastroc.	0.39	54.6	5-57	11.1	30	2.16
6	adduc. mag.	0.52	31.0	∞-34	10.0	20	2.20
7	gastroc.	0.43	43.0	5-44	9.4	30	2.80
8	sartorius	0.39	30.5	∞-30.5	13.0	20	2.25
9	gastroc.	0.49	47.5	5-50	11.6	20	2.70

values derived from these data are plotted,—the voltage V , the quantity Vt and the energy V^2t against the duration t . The $Vt-t$ relation is a good straight line, and the curve V^2t-t has a minimum at $t = a/b$.

There were, however, several cases in which the observed values of V for long durations deviated from what were expected from Weiss' law. Tables 2 and 3 give such examples. In table 2, the values of V for the durations over 3 msec. are consistently smaller than those given in the last column, that is to say, the coefficient b in Weiss' formula is larger than the observed rheobase. In the case given in table 3, on the contrary, the coefficient b is distinctly smaller than the rheobase.

Table 4 gives all of the results obtained between December, 1937 and January, 1938. In all cases, between 0.1 and 3.0 msec., the data agree well with Weiss' formula. For durations over 3.0 msec., in 5 cases (nos. 2, 4, 5, 8 and 9) the agreement is still good; in 2 cases (nos. 3 and 7) the observed values of V are a little larger than the calculated ones; in the

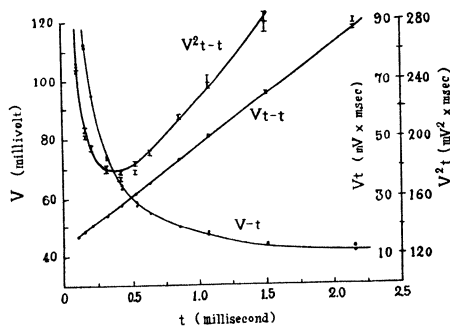

Fig. 5

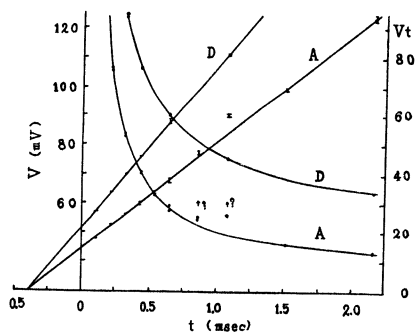

Fig. 6

Fig. 5. The $V-t$, the $Vt-t$ and the V^2t-t relations in the normal nerve fiber drawn from the data in table 1. See also table 4, no. 4.

Fig. 6. The $V-t$ and $Vt-t$ relations obtained by ascending (A) and descending (D) current excitation. See table 4, no. 5. The point at which the $Vt-t$ lines cross the abscissa indicates the theoretical chronaxie (Wago and Wakabayashi, 1936), namely, the ratio a/b of the coefficients in Weiss' formula.

remaining 2 cases (nos. 1 and 6) the strength is approximately constant for long durations.

B. Ascending current. Figure 6A shows the $V-t$ and $Vt-t$ relations. The $V-t$ relation can best be represented by an equilateral hyperbola. The time constant a/b is approximately equal to those obtained with descending current pulses.

In ascending current stimulation, the threshold is sometimes quite unstable at certain durations and deviates markedly from what is expected from the remaining part of the $V-t$ curve by interpolation. In figure 6, this is seen at 0.86 and 1.075 msec. This phenomenon is probably due to anodal depression at the node of Ranvier on the distal side of the ridges (N in fig. 2). For strengths over the values expected from the $V-t$ curve, impulses should be set up at the central node (N' in fig. 2), but these im-

pulses seem to be blocked at the distal node before they reach the muscle. It is interesting that this block happens at only a part of the $V-t$ curve.

II. Polarized nerve fiber. Figure 7 shows the result obtained with descending current pulses during electrotonus. The nerve fiber was first cathodally polarized with a constant potential-difference of 10 millivolts, and test current pulses were superimposed upon this polarizing current. Then the polarizing current was discontinued and the $V-t$ relation of the unpolarized nerve fiber was determined. Lastly the direction of the polarizing current was reversed and the effect of anelectrotonus was investigated.

The $V-t$ relation is still an equilateral hyperbola and, as many investigators have already shown, the chronaxie (or a/b) is shortened by anelectrotonus and lengthened by catelectrotonus.

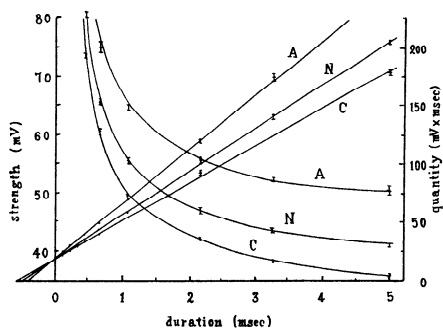

Fig. 7

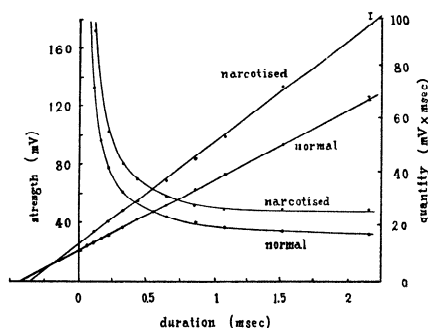

Fig. 8

Fig. 7. Strength-duration relations in the polarized nerve fiber. C: catelectrotonus. N: normal. A: anelectrotonus. Sciatic-gastrocnemius preparation. Internodal distance, 2.69 mm. Pause between stimuli, about 25 seconds. Temperature, 9.8°C.

Fig. 8. Strength-duration relation in the narcotized nerve fiber. Same preparation as used for the experiment of table 3. The normal $V-t$ curve is derived from table 3. A 0.5 per cent urethane-Ringer solution was used. See table 4, no. 1.

III. Narcotized nerve fiber. It has been shown (Tasaki, 1938b), with single nerve fibers that the rheobase and the chronaxie remain at an approximately constant level during the action of a narcotizing solution of constant concentration and do not change progressively as in a nerve trunk. The voltage rises and the chronaxie falls promptly as soon as a narcotizing solution (below the critical concentration) is applied to the isolated region of the nerve fiber and then at once an approximately steady state is reached. The value of the rheobase or the chronaxie depends solely upon the concentration of narcotic employed. It is therefore possible to determine the $V-t$ relation of a narcotized nerve fiber in a steady state.

Figure 8 shows the effect of narcosis upon the $V-t$ relation. It is clear

that the voltage rises and the chronaxie shortens in narcosis and that Weiss's formula is still applicable to the $V-t$ relation. This experiment is difficult, because during narcosis the irritability is less stable than in the normal nerve fiber.

As the concentration of the narcotic is increased, the change in the rheobase and the chronaxie becomes greater. The following example will give a rough estimate of this concentration-effect. In the normal state (sciatic-sartorius preparation, 13°C.) the rheobase was 38.5 millivolts and the chronaxie was 0.42 msec. These values were changed by the action of an 0.005-per-cent cocaine-Ringer solution to about 70.5 millivolts and 0.35 msec. When the concentration was increased up to 0.01 per cent, the rheobase rose to 80 millivolts and the chronaxie fell to 0.33 msec. At 0.02 per cent, however, the chronaxie was lengthened to about 0.45 msec. ("abnormal prolongation"), while the rheobase rose further to 105 millivolts. By further (but slight) increase of concentration (0.025 per cent), the nerve fiber was rendered immediately incapable of conducting an impulse through the narcotized region.

The abnormal prolongation of the chronaxie by narcosis appears only near the critical concentration (that is, the minimal concentration in which the isolated nerve fiber loses its conductivity). If three or more nodes of Ranvier are exposed in the narcotized region, this seldom occurs. An explanation of this phenomenon will be presented elsewhere.

In the narcotized nerve fiber, the anodal depression is more marked than in the normal; therefore it is almost impossible to determine the $V-t$ relation with ascending current pulses. It is apparent that, when the narcotized region of a nerve trunk is electrically excited, the nerve impulse is often conducted only in a single direction.

The change in the threshold brought about by the action of a narcotic is much less marked in the isolated nerve fiber than in the nerve trunk. Especially when brief current-pulses (or induction shocks) are used, the rise of the threshold is slight. The remarkable change in the threshold in the narcosis of a nerve trunk should therefore be ascribed mainly to the increase in the electric resistance of the non-excitabile tissues which surround the nerve fibers.

IV. Effect of connective-tissue sheath. Bishop (1928) and Grundfest (1932) have shown that the $V-t$ relation, and with it the chronaxie, varies with the amount of connective tissue which separates the electrode and the nerve fiber. Figure 9 shows an example of similar results. First, the intact nerve trunk of the preparation was stimulated with a set of non-polarizable electrodes, and the relation (I) in the figure was obtained. Then, the connective-tissue sheath at the stimulated region was carefully removed by the method illustrated in figure 1. The nerve trunk was mounted on the electrodes as before, and the $V-t$ relation was determined

(curve II). Next the connective tissue inside the sheath was further torn by teasing and separating the nerve fibers from one another. Determination of the $V-t$ relation gave the curve (III) in figure 9.

In this type of experiment, the same spot of one and the same nerve fiber is brought into play in all cases. It is therefore obvious that not only the rheobase but also the chronaxie is markedly reduced by removal of the connective-tissue sheath and further by separation of the connective tissue inside the sheath. There are apparently two possible explanations of this effect: one is the change in the degree of distortion of the stimulating current by polarization of the connective tissue; the other is the change in the distribution of potential along the active nerve fiber by removal of the connective tissue. The present research does not indicate which one is most important. In a later paper, however, I will show that the latter effect is of great significance in the explanation of Bishop's, Grundfest's and my own experimental results.

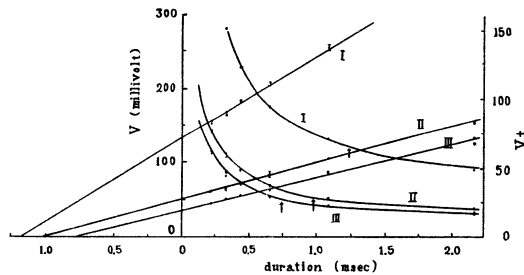

Fig. 9. Strength-duration relations obtained before (I) and after (II and III) removal of the connective tissue sheath. Sciatic-adductor magnus preparation. Electrodes: Zn-ZnSO₄-Ringer (gelatin) type, diameter 5 mm., interpolar distance 5 mm. Arrows mark the chronaxie. Rheobase: in (I), 59 mV; in (II), 27.5 mV; in (III), 25 mV. Temperature, 8.7°C. Pause between stimuli, about 10 seconds.

DISCUSSION. The greatest advantage of the new method of stimulating a nerve fiber on a "ridge-insulator" is that the electrode circuit is not short-circuited by the conducting medium which surrounds the nerve fiber. Each pool of Ringer's solution on both sides of the insulated region can be treated as being always equipotential. There is no potential difference along the fiber except across the insulating ridges. Therefore, the drop of potential across the insulated region, which obviously acts upon the nerve fiber, is equal to the applied voltage.

The objection may be raised to this method, however, that the injury potential of the dissected nerve fibers may produce an appreciable effect upon the isolated nerve fiber. Such an effect, if it exists at all, would be equivalent to that of cat- or anelectrotonus caused by a weak constant current. It can be diminished by isolating as long a section of the nerve

fiber as possible and leaving the preparation in Ringer's solution for a few hours prior to experimentation. The approximate equality of the observed chronaxie for descending and ascending current pulses shows that such an effect is insignificant.

Much work has been done in the past on constant-current stimulation of the nerve, but none of it is free from the effect of non-excitabile tissues which surround the nerve fiber under investigation. In the present experiments we are dealing with isolated single nerve fibers. The result obtained, therefore, in one sense, gives the standard $V-t$ relation in the nerve fiber. Since, however, it is shown that it is possible that the $V-t$ relation varies with the change of distribution of potential along the nerve fiber, it would be absurd to speak of the true or ultimate $V-t$ relation.

SUMMARY

1. A modification of Shimizu and Kaku's method for isolating a single nerve fiber is described.

2. A method is described for stimulating an isolated myelinated fiber by insulating the internode on a "ridge-insulator," and the superiority of this method over the usual method is stressed.

3. The strength-duration relations were determined by the new method on the normal, narcotized and polarized nerve fiber of the toad. All the results were found to be in best accord with Weiss's empirical formula.

4. In the normal nerve fiber (at 10–15°C.), the chronaxie was found to be 0.3–0.5 msec., and the rheobasic voltage was 25–50 millivolts.

5. Sometimes with ascending current pulses, the threshold cannot be determined, due probably to block of the descending nerve impulse by the anodal depression. This occurs more frequently in the narcotized nerve fiber; the preparation sometimes gives no response for all pulse durations over a fraction of a millisecond.

6. At the same point on the nerve trunk of a motor-unit preparation, the strength-duration relation was determined before and after removal of the connective-tissue sheath. Confirming Bishop's previous result, the chronaxie in the nerve devoid of the sheath was found to be about half as long as that in the intact nerve. This effect of the connective-tissue sheath was inferred to be due to the decrease in the gradient of potential along the nerve fiber inside.

It is my wish to express to Prof. G. Kato my appreciation of his continual encouragement. To Dr. H. Davis my thanks are due for his kindness in improving the English.

REFERENCES

- ADRIAN, E. D. AND D. W. BRONK. *J. Physiol.* **66**: 81, 1928.
BISHOP, G. H. *This Journal* **84**: 417, 1928.

- GRUNDFEST, H. *J. Physiol.* **76**: 95, 1932.
- KATO, G. *The microphysiology of nerve.* Tokyo, 1934.
Cold Spring Harbor Symposia on Quantitative Biology, IV, 1936.
- LAPICQUE, L. *C. r. Soc. de biol.* **78**: 898, 1906.
L'excitabilité en fonction du temps. Paris, 1926.
- LUCAS, K. *J. Physiol.* **35**: 310, 1907.
- TASAKI, I. See G. KATO. *The microphysiology of nerve*, p. 74, 1934.
Proc. Japan. Physiol. Soc., Biophysics, **4**: no. 4, 1936.
Keio Igaku (Japanese) **18**: 337, 1938a.
Nihon Seiri Z. (Japanese) **3**: 65, 1938b.
- WAGO, U. AND T. WAKABAYASHI. *Japanese J. Med. Science. III. Biophysics.* **4**:
no. 1, 1936.