

# Membrane Conductance and Current-Voltage Relation in the Squid Axon Under 'Voltage-Clamp'<sup>1</sup>

I. TASAKI AND C. S. SPYROPOULOS

*From the Laboratory of Neurophysiology, National Institute of Neurological Diseases and Blindness, National Institutes of Health, Bethesda, Maryland*

## ABSTRACT

TASAKI, I. AND C. S. SPYROPOULOS. *Membrane conductance and current-voltage relation in the squid axon under 'voltage-clamp.'* Am. J. Physiol. 193(2): 318-327. 1958.—The conductance of the squid axon membrane under 'voltage-clamp' was measured by superposing a sinusoidal wave upon rectangular clamping voltage pulses. It was possible to determine the time course of the emf of the membrane under 'voltage-clamp' on a single photographic record showing the membrane current together with the simultaneously recorded membrane conductance. The properties of the membrane in the mixed state, in which only a portion of the axon membrane is in the excited state, were investigated by the same method. The property of the weak variable inward membrane current which preceded the appearance of discrete inward surges was investigated.

THE MEMBRANE conductance of the squid axon under 'voltage-clamp' has been determined by Hodgkin, Huxley and Katz (1) by measuring the slopes of the curve relating the membrane current and potential at various levels of depolarization. This method of determining the conductance is valid if the surface membrane of the axon under 'voltage-clamp' is spatially uniform. In the preceding paper (2), it was shown that, when the axon membrane was depolarized by rectangular clamping pulses greater than about 50 mv, the clamped portion of the membrane is excited more or less uniformly. Based on this finding, we calculated the conductance of the active membrane by the method mentioned above. In the range of depolarizations between 20 and 35 mv, however, we found that the axon membrane is spatially nonuniform, only a part of the membrane being in the active state. It seemed to us worth while, therefore, to re-examine the dependence of the membrane conductance upon the amplitude of the clamping pulses by a new method.

The method of measurement employed in

the present investigation was to clamp the membrane potential with a sinusoidal wave superposed upon rectangular voltage pulses of varying amplitudes. By this method it was possible to determine the conductance of the membrane independently of the membrane current.

## METHODS

The method of dissecting squid axons and of introducing internal electrodes was the same as that adopted in previous investigations (2, 3). The internal electrode set consisted of two 50 $\mu$  silver wires; the current-electrode had an exposed surface of about 15 mm long and the potential-electrode of about 4 mm located in the middle of the current-electrode. The axon was mounted on a plate provided with two partitions which divided the sea water on the plate into three pools. After the axon was thrust with the electrodes, these partitions were sealed with vaseline. The partitions were about 1.5 mm thick. In most of our experiments, the middle pool was approximately 7 mm wide. The two lateral pools were directly grounded by large electrodes, and the external potential-electrode,  $E'_p$ , the external current-electrode,  $E'_c$ , and the internal electrodes were connected to the voltage-clamp arrangement

Received for publication November 7, 1957.

<sup>1</sup> The work presented in this article was carried out at the Marine Biological Laboratory, Woods Hole, Mass.

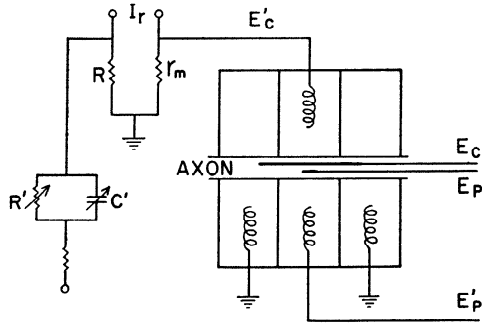

FIG. 1. Diagram showing the arrangement of the internal and external electrodes used for measuring the conductance of the squid axon membrane under voltage-clamp. The giant axon and the internal electrodes are drawn disproportionately thick. The internal current-electrode,  $E_c$ , the internal potential-electrode,  $E_p$ , and the external potential-electrode,  $E_p'$ , were connected to the arrangement shown in fig. 1A in a previous paper (3). The circuit on the left-hand side is a device to balance out the excursion of the oscillograph beam caused by the membrane current at rest.

shown in diagram A in figure 1 in the previous paper (3).

In the experiments of figures 6 and 7, the axon was mounted on a plain glass plate without any partition; in this case there were no grounding electrodes in the pool.

Rectangular voltage pulses for clamping the membrane potential were obtained from a Tektronix pulse generator (type 161) by reducing its output voltage with a potential divider consisting of a 40-kilohm resistor and a 100-ohm resistor. The output terminal (single ended) of a beat-frequency oscillator (General Radio type 1304-A) was connected to an attenuator and then, through a 10-kilohm resistor, to the 100-ohm resistor to which the output of the pulse generator was connected. The amplitude of both the a.c. and rectangular components in the clamping voltage could be controlled independently of each other.

When the membrane of an axon was clamped by this mixed voltage pulse, resistance  $r_m$  in figure 1 was traversed by a mixture of a slowly changing membrane current and a sinusoidal component. Neglecting the transient current at the beginning of the clamping pulse, the membrane current,  $I$ , can be expressed by the formula

$$I = (g + j\omega c)Ae^{j\omega t} + g(V - E), \quad (1)$$

where  $c$  is the capacity of the membrane in the middle pool,  $g$  the conductance (i.e. the re-

ciprocal of the resistance) of the membrane,  $Ae^{j\omega t}$  the a.c. voltage by which the membrane is clamped,  $V$  the rectangular clamping pulse and  $E$  the effective membrane-emf (i.e. the membrane potential for  $I = 0$ ). This equation is approximate, since we have neglected small changes in the capacitive current (which may arise from a possible change in  $c$  during voltage-clamp and also from the possible series arrangement of the capacity relative to the emf of the membrane). When the amplitude of the a.c.-voltage is maintained at a low level, the time course of the slowly changing membrane current,  $g(V - E)$ , should coincide with that determined without a.c. The membrane current recordable before the start of the rectangular component in the clamping pulse,  $I_0$ , is given by

$$I_0 = (g_0 + j\omega c)Ae^{j\omega t}, \quad (2)$$

where  $g_0$  is the conductance of the membrane in the middle pool at rest.

In our measurement of the membrane current, the current given by equation 2 was subtracted from the total membrane current expressed by equation 1. This was accomplished by adjusting condenser  $C'$  and resistors  $R$  and  $R'$  in the diagram and by recording the potential difference between  $R$  and  $r_m$  with a differential amplifier. The membrane current,  $I_r$ , recorded by this method is therefore given by

$$I_r = (g - g_0)Ae^{j\omega t} + g(V - E). \quad (3)$$

In the experiments of figures 2 and 3, we are interested in large increases in the membrane conductance; namely,  $g \gg g_0$ . In this case, equation 3 reduces to

$$I_r = gAe^{j\omega t} + g(V - E). \quad (4)$$

This equation states that it is possible, by the use of the present method, to determine the time courses of both the membrane conductance,  $g$ , and the membrane-emf,  $E$ , on a single oscillograph record showing the time course of  $I_r$  (see RESULTS).

Most of the experiments in this series were carried out at low temperature ( $4-6^\circ\text{C}$ ) with an a.c. frequency of 8 kc/sec. ( $\omega$  being  $5 \times 10^4$  sec. $^{-1}$ ) or 16 kc/sec. Some of the experiments were made at room temperature ( $22^\circ\text{C}$ ) with an a.c. frequency of 16 kc/sec. The value of resistor  $r_m$  was in general 10 ohms,  $R$  was about 15 ohms in the experiments with an a.c. at

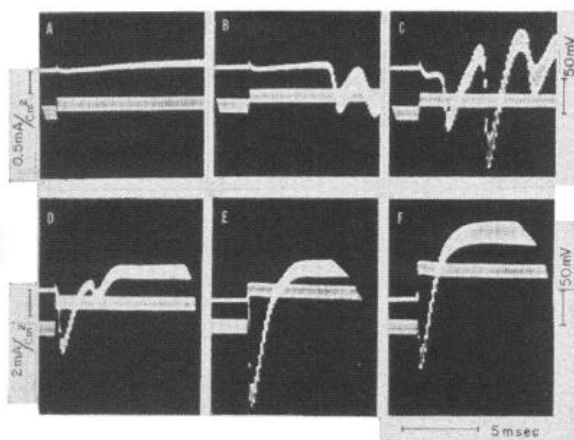

FIG. 2. Voltage-clamp with a high-frequency sinusoidal wave superposed on rectangular voltage pulses. Lower trace displays the time course of the clamping voltage; upper trace, the membrane current recorded by the method shown in fig. 1. The value of  $r_m$  was 10 ohms,  $R$  13 ohms,  $C'$  0.007  $\mu\text{f}$ , and  $R'$  of the order of 1 megohm. The frequency of a.c. was 8 kc/sec. Temperature, 5°C. Diameter of axon, 400  $\mu$ . Note that the sensitivity of the current trace is different in the 2 rows.

8 kc/sec. and 100 ohms when the a.c. frequency was 16 kc/sec. Condenser  $C'$  was variable in the range below 0.01  $\mu\text{f}$  and resistor  $R'$  had a range between 1 and 2000 kilohms. The source of a.c. was connected to condenser  $C'$  through a fixed resistor of 10 kilohms. The difference between the IR-drop across  $r_m$  and that across  $R$  was recorded with a differential amplifier (Tektronix type 122) and was taken as a measure of the membrane current. In some of the experiments described in the present paper, the a.c.-component in the membrane current was separated from the slowly changing component by means of an electronic filter (Spencer-Kennedy Laboratory, Model 302).

## RESULTS

**1. Membrane Conductance at Peak of Initial Inward Surge.** When the potential difference between the internal and external potential-electrodes ( $E_p$  and  $E'_p$  in fig. 1) is clamped by a sinusoidal wave of 8 kc/sec. in frequency, the axon membrane is traversed by an a.c. of the same frequency. Since the resistance of the membrane in the middle pool in figure 1 is of the order of 10 kilohms and its capacity was around 0.1  $\mu\text{f}$ , the current flow through the membrane in this case is almost

purely capacitative. This current produces a potential drop across the small resistance,  $r_m$ , in the figure, connected to the current-electrode in the middle pool.

By a proper adjustment of variable condenser  $C'$  and variable resistance  $R'$ , it was always possible to make the potential drop across  $R$  equal in amplitude and in phase to that across  $r_m$ . When this adjustment was made, the current trace of the oscillograph, displaying the potential difference between  $r_m$  and  $R$ , remained narrow during the period of voltage clamping with the sinusoidal wave. When a rectangular depolarizing pulse was superposed upon the sinusoidal clamping wave, the current trace was found to start broadening, indicating that the membrane conductance was increased by the clamping pulse. Some of the oscillograph records obtained by this method are presented in figures 2 and 3. In these records, the lower trace represents the time course of the potential difference between the internal and external potential-electrodes maintained at various levels by the voltage-clamp arrangement. The upper trace shows the configuration of the ohmic component of the membrane current separated from the capacitative component by the technique mentioned above.

In record A figure 2, the clamping pulse was subthreshold for discrete responses; there is in this record a slight and gradual broadening of the current trace. We shall discuss this gradual change in the membrane conductance in some detail later. In record B, repetitive surges of inward membrane currents started after a long latency. It is seen that these discrete inward surges are accompanied by a simultaneous broadening in the oscillograph beam, indicating that there was a large increase in the membrane conductance associated with the surges. When the size of the clamping pulse was increased, inward surges appeared at shorter latencies. There was always a distinct increase in the membrane conductance when the membrane was clamped at these levels.

It is clearly seen in the records of figures 2 and 3 that the membrane conductance at the peak of the inward surges does not vary with the amplitude of clamping pulses as much as the membrane current does. For clamping

pulses above approximately 50 mv, namely for pulses strong enough to evoke a single surge of inward membrane current (record *E* and *F* in figure 2 and records in column *A* in fig. 3), the amplitude of the sinusoidal current at the peak of the inward surge is practically independent of the size of the clamping pulse. This indicates that the membrane conductance reached the same peak value in this range of membrane depolarization.

It has been shown in the preceding paper (2) that, when the clamping level is higher than about 50 mv above the resting potential, the membrane is excited uniformly along the internal electrodes by the clamping pulse. It is also known that, in this range of membrane depolarization, the peak value of the membrane current decreases linearly with increasing pulse amplitude (p. 477 in ref. 4, p. 873 in ref. 5). Therefore, the slope of the curve relating the membrane current,  $I$ , and the voltage,  $V$ , has been taken as a measure of the conductance across the active membrane.

There is good reason to believe that the conductance obtained from the slope of the  $I$ - $V$  relation should coincide with the value determined by the a.c. method in this range. When we change the clamping level suddenly at the peak of the inward current, as Hodgkin and Huxley (4) did, the intensity of the membrane current is found to change immediately to the value expected from the slope of the  $I$ - $V$  relation in this range. The a.c.-component in the clamping pulse can be regarded as a rapid change in the clamping level at the peak of inward current. We shall show later that the values obtained by the two methods agree with each other numerically.

For clamping pulses smaller than about 40 mv, the intensity of the inward membrane current decreased with decreasing pulse amplitude. When a comparison was made of the conductances at the peaks of the inward surges with a short latency, e.g. on the two records in column *B* in figure 3 or records *D* and *E* in figure 2, it was found that in this range of membrane depolarization there is an approximate proportionality between the intensity of the inward current and the conductance at the peak. The inward surges which appeared at long latencies were accompanied by relatively greater conductance increases.

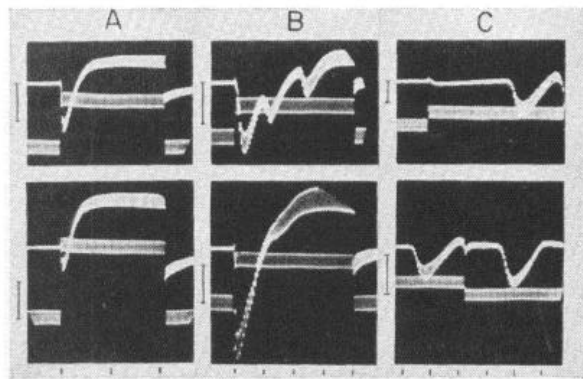

FIG. 3. Similar to the experiment of fig. 2. Voltage calibration, 50 mv for all of the three examples in the figure. The current calibration, 5 ma/cm<sup>2</sup> for axon *A*, and 1 ma/cm<sup>2</sup> for both *B* and *C*. Time markers, 5 msec. for *A* and 2 msec. for *B* and *C*. All the records were taken at about 5°C. In *C* the upper record shows the membrane current near the onset and the lower record near the end of the rectangular clamping pulse of about 10 msec. in duration.

The records in column *C* in figure 3 show that the inward surges which appeared after the end of the rectangular pulse (the membrane being still clamped at the level of the resting potential) was also associated with concomitant increase in the membrane conductance.

**2. Membrane Conductance in the 'Mixed' State.** The term 'mixed' state was introduced in a previous paper (5) to describe the state of the membrane of which a fraction is responding and the remaining fraction is resting. When a uniform resting membrane is excited or when an action potential in a uniform membrane is abolished by a short pulse of electric current, the membrane is considered to pass through a mixed state. Under the so-called voltage-clamp conditions, the regenerative process of restimulation by local currents is strongly suppressed by the clamping device. We have seen in the preceding paper (2) that a fraction of the axon membrane can stay in a state of repetitive excitation for a considerable length of time under such conditions.

On the basis of the experimental facts described in this series of papers, it is now possible to investigate the properties of the membrane in the mixed state more closely. In the diagram of figure 4, the thick V-shaped curve represents the current-voltage ( $I$ - $V$ ) relation determined by the method of voltage-

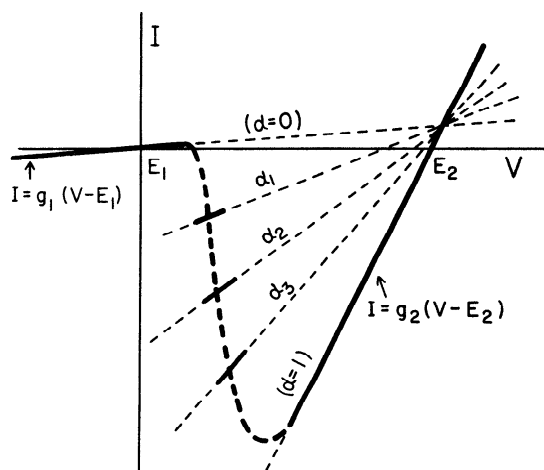

FIG. 4. Current-voltage diagram illustrating the resting state of the membrane ( $\alpha = 0$ ), the active state ( $\alpha = 1$ ) and the mixed states.  $E_1$  represents the potential level of the resting membrane and  $E_2$  the peak value of the action potential. The parts of the  $I$ - $V$  curve shown by the thick solid and broken lines have been actually observed by experiment. For further detail, see text.

clamp. Symbols  $E_1$  and  $E_2$  denote the level of the resting potential and the peak value of the action potential respectively. The straight line passing through point  $E_1$  represents the  $I$ - $V$  relation for the resting membrane. The other straight line crossing the abscissa at  $E_2$  shows the relation between the peak value of the inward current and the amplitude of the depolarizing voltage pulse. The broken line connecting the two straight lines corresponds to the discontinuous, labile portion of the  $I$ - $V$  relationship.

We denote the straight line crossing  $E_2$  by

$$I = g_2(V - E_2), \quad (5a)$$

where  $g_2$  is the conductance of the uniformly active membrane. Similarly, the straight line passing through  $E_1$  is denoted by

$$I = g_1(V - E_1), \quad (5b)$$

in which  $g_1$  is the conductance of the resting membrane. When a fraction  $\alpha$  of the total area of the membrane is active, the total membrane current should be given by the sum of the current through the active area and that through the resting area. The  $I$ - $V$  relation in the mixed state, therefore, is given formally by

$$I = \alpha g_2(V - E_2) + (1 - \alpha)g_1(V - E_1). \quad (6)$$

The linear relationship between  $I$  and  $V$  expressed by this equation is shown by the thin

broken lines in the diagram. Since the conductance of the active membrane,  $g_2$ , is about 300 times as large as the conductance of the resting membrane,  $g_1$ , in the squid axon, the second term in equation 6 can be omitted without a serious loss of accuracy. The approximate  $I$ - $V$  relation in the mixed state is therefore described by

$$I = \alpha g_2(V - E_2). \quad (7)$$

The active fraction,  $\alpha$ , can vary with a small change in the potential drop across the axon surface,  $V$ . If  $V$  is increased at a slow rate at the peak of an inward surge,  $\alpha$ , is expected to increase with increasing  $V$ , thus giving a negative slope conductance,  $dI/dV$ , because  $(V - E_2) < 0$  when  $\alpha < 1$ .

In the conductance measurement under voltage-clamp, a sinusoidal wave,  $A \sin \omega t$ , is superposed upon a rectangular pulse  $V$ . We may regard this superposed sinusoidal wave as a succession of short pulses of the amplitude  $A$  and of the duration of the order of  $2/\omega$ . At 8 kc/sec., the value of  $2/\omega$  is 40  $\mu$ sec. It will be shown by one of us (C.S.S.) that, at 4-6°C, the minimum intensity necessary to evoke a discrete inward membrane current by a pulse of this duration is of the order of 200 mv. The amplitude,  $A$ , of the sinusoidal wave used to measure the conductance, which was 4-8 mv, is therefore, well below the threshold for pulses of this duration. It is expected therefore that the active fraction,  $\alpha$ , remains practically unaffected by the superposed sinusoidal wave. Under these circumstances, the conductance measured by the a.c. method is expected to give a value  $\alpha g_2$ . These slopes of the  $I$ - $V$  relation in such mixed states are shown by the short thick lines in figure 4 for three different values of  $\alpha$ .

It was pointed out in the preceding section that, in the range of membrane depolarization between 20 and 35 mv, the conductance at the peak of the inward surge with a short latency is roughly proportional to the intensity of the inward surge. In this narrow range of  $V$ , the value of  $(V - E_2)$  in equation 7 varies only slightly (i.e. between 75 and 90 mv). Therefore, the maximum inward current,  $I$ , should vary roughly with  $\alpha g_2$ , and this is actually what has been observed in our experiments. We are justified, therefore, in conclud-

ing that the portions of the  $I$ - $V$  relation for mixed states shown by the short thick lines in figure 4 have been directly demonstrated in our experiments.

We have seen that the diagram of figure 4 is very helpful in understanding the behavior of the excitable membrane in the two stable states and in mixed states. This method of illustrating the behavior of the excitable membrane was kindly suggested to us by Prof. U. F. Franck from Darmstadt, Germany, and also by Prof. T. Teorell from Uppsala, Sweden, when they visited our laboratory in April of 1957. There is some formal resemblance between various models of nerve excitation (cf. e.g. 6) and the process in the squid axon discussed in this section.

It may be added to the argument in this section that the experimental data upon which our conclusion mentioned above is based has not been influenced by the nonuniform polarization of the internal electrodes appreciably. When a pulse of current is sent through a fine silver electrode, there is a certain delay in the development of polarization; the time constant of development of the polarization potential was 0.3–0.4 msec. in our electrodes (see DISCUSSION in ref. 2). At the peaks of initial inward surges discussed in this section, the effect of electrode polarization is considered to be relatively small.

**3. Time Course of Membrane-EMF During Voltage-Clamp.** In this section, we are concerned with the time course of the emf of the squid axon membrane under the so-called voltage-clamp conditions. We limit our consideration in this section to the state of the membrane depolarized by rectangular clamping pulses larger than about 50 mv. In this range of membrane depolarization, there is no serious spatial nonuniformity along the clamped axon membrane. The change in the resistance of the internal current-electrode by polarization has very little effect upon our measurements, because there was, as a rule, a series resistance of 1–3 kilohms between the internal current-electrode and the feedback amplifier ( $A_2$  in fig. 1 in ref. 3).

The membrane current  $I_r$ , recorded by the present method consists of two components, the a.c.-component,  $I_a \sin \omega t$ , and the remaining slowly changing component,  $I_s$ . Both the amplitude of the sinusoidally alternating com-

ponent,  $I_a$ , and the intensity of the slowly changing component,  $I_s$ , vary with time during voltage-clamping. Replacing the recorded membrane current in *equation 4* under METHODS with the sum of these components, we have

$$I_a \sin \omega t + I_s = gA \sin \omega t + g(V - E). \quad (8)$$

(In this equation, the complex notation for the sinusoidal components have been replaced with the real notation.) From this it follows immediately that

$$I_a = gA, \quad \text{and} \quad I_s = g(V - E). \quad (9a \text{ and } 9b)$$

The first equation, (9a), states that the conductance  $g$  is equal to the ratio  $I_a/A$ . Introducing this ratio into *equation 9b* and rearranging the times, we have

$$E = V - A(I_s/I_a). \quad (10)$$

All the terms in the right-hand members of this equation can be determined from the two traces in one photographic record (e.g. record  $F$  in fig. 2) as functions of time. (Note that  $V$  is the size of the rectangular component of the clamping pulse,  $A$  the amplitude of the sinusoidal component in the clamping pulse,  $I_a$  the sinusoidal component in the membrane current and  $I_s$  the remaining slow component in the membrane current.) Therefore, the time course of the membrane-emf can be determined on each one of the records obtained by the present method.

Based on the result of *equation 10*, we calculated the time course of the membrane-emf during voltage-clamping on several photographic records. An example of our calculation is presented in figure 5. There are several interesting features in our results of calculation.

In the first place, it was found that the peak value of the calculated membrane-emf agreed with the observed peak value of the action potential recorded by the conventional method (under space-clamp with no membrane current). This fact indicates that the conductance determined by the a.c. method agrees with the conductance measured from the slope of the  $I$ - $V$  relation for depolarizations greater than about 50 mv (as has been pointed out in section 1 of the present paper). This also shows that our records of the a.c. components are not contaminated by artefacts to any appreciable extent.

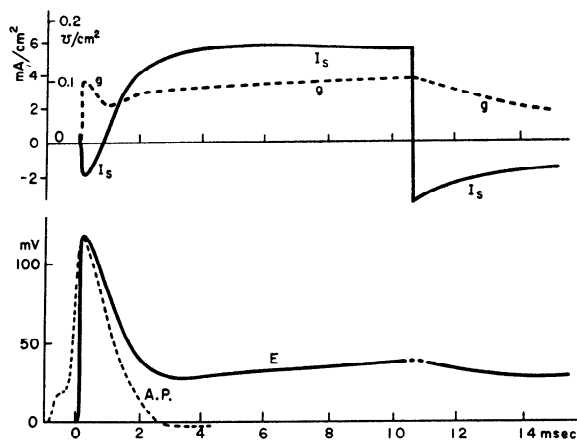

FIG. 5. The result of measurement of the lower record in fig. 3A. Curve  $I_s$  represents the course of the mid-point of the broadened current trace,  $g$  the ratio of the width of the current trace ( $I_a$ ) to that of the potential trace ( $A$ ), and trace  $E$  showing the time course of the membrane-emf was obtained by calculating the value of  $V - A(I_s/I_a)$ , where  $V$  is the amount of discontinuous rise in the potential trace. The broken line shows the time course of the action potential recorded internally by the conventional method.

Secondly, it was found that the value of  $E$  fell rapidly as the conventional action potential did. The divergence of the time course of  $E$  from that of the action potential of the same axon was greater when there was a stronger membrane current. Thirdly, with relatively strong depolarizing pulses, the value of  $E$  stayed always above the level of the resting potential. When there was a strong outward membrane current during voltage-clamping, the value of  $E$  was found to rise again after a minimum was reached at the end of the rapid falling phase. Finally, both the conductance,  $g$ , and the membrane-emf,  $E$ , showed a continuous change at the end of the clamping pulse.

Our present interpretation of the finding mentioned in the last paragraph is as follows: from the consideration of the charges of the ions in- and outside the membrane, it is clear that a steady outward membrane current is carried by potassium ions in the axoplasm and/or by chloride ions in the medium. According to Hodgkin and Huxley (7), the axon membrane is impermeable to chloride ions in the steady state. It is expected therefore that, by the mechanism investigated by Nernst (8) fifty years ago, a continuous outward membrane current raises the concentration of

potassium chloride in the space immediately outside the membrane. It is well known that a rise in the potassium concentration outside the axon membrane raises the membrane potential above the normal resting potential (decreasing the absolute value of the membrane potential) and increases the membrane conductance. We explain the gradual rise in  $E$  and  $g$  shown in figure 5 as a result of this electrophoretic effect of the outward membrane current. Similarly, we may attribute the divergence of the falling phase of  $E$  from the falling phase of the action potential to the electrophoretic effect of the inward (and outward) membrane currents.

**4. Subthreshold, Variable Inward Membrane Current Under Voltage-Clamp.** In the preceding papers (2, 3), it was pointed out that, when the clamping pulse was near the threshold for discrete inward membrane currents, a small, variable inward membrane current could be observed prior to the start of the discrete inward surges. In fresh, normal axons, this variable inward current was about  $50 \mu\text{a}/\text{cm}^2$  or less. When the strength of the clamping pulse was increased slightly above the threshold level, the latency of the first discrete surge was markedly reduced. It was possible, however, to recognize the existence of the variable inward current which preceded the discrete surge (see e.g. record C in fig. 2). This variable inward surge showed no threshold or a latency comparable to that of the discrete inward surges. With stronger depolarizing pulses, the latency of the discrete surge was shortened further and the variable component could not be recognized.

We found that this variable inward current was sensitive to the concentration of the sodium in the surrounding sea water. The tracings in figure 6 show this effect of lowering the sodium content upon the variable component of the membrane current as well as upon the threshold for discrete surges. The two traces, marked  $I$  and  $I'$ , in each diagram were taken from an axon at the same strength of the clamping pulse before and after reducing the external sodium concentration. A pronounced reduction in the intensity of the variable inward current is obvious. A similar reduction in the variable inward current was observed when a small amount of ethyl-

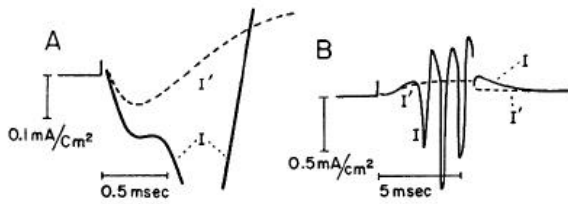

FIG. 6. *A*: effect of lowering the sodium in the medium upon the variable and discrete inward membrane currents under voltage-clamp; *I*, the membrane current for depolarization of 20 mv in normal sea water, and *I'* the current observed after reducing the sodium in sea water by 25%; temperature 22°C. *B*: same as *A*, except that both the sensitivity of the current trace and the sweep speed were much lower (different axon); clamping pulse, 22 mv and the reduction of the sodium concentration 50%.

urethane was added to the sea water in which the axon was immersed.

Under low sodium or light narcosis, it was found that the maximum intensity of the variable inward current could be increased appreciably by increasing the amplitude of the clamping pulse. Since the threshold for a discrete surge was markedly increased under these abnormal conditions, much stronger depolarizing clamping pulses could be used to demonstrate the variable component. When the effect of narcosis or of low sodium was strong enough to eliminate the property of the normal axon to produce all-or-none responses (see fig. 7 in ref. 3), a smooth variable inward current of about  $200 \mu\text{a}/\text{cm}^2$  without being followed by discrete surges could be observed in the range of depolarization between 40 and 60 mv. A further increase in the depolarizing clamping pulse decreased the intensity of the variable inward current.

Since the variable inward current had these signs of 'active' processes in the membrane, we made an attempt to detect an increase in the membrane conductance associated with the variable inward current. The method of conductance measurement used in section 1 did not give a sensitivity high enough to examine the property of the membrane at sub-threshold levels for discrete surges. Therefore, we amplified the potential difference between  $r_m$  and  $R$  in figure 1 by a factor of 1000 and then led the output of the amplifier to an electronic filter tuned to the frequency of the clamping a.c. The amplitude of this filtered a.c. was taken as a measure of the membrane conductance and the unfiltered output of the

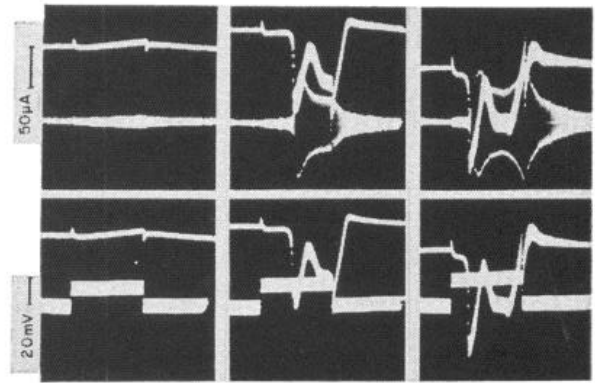

FIG. 7. An example of the records obtained by the method of filtered a.c. for measuring the conductance of the squid axon membrane under voltage-clamp. Temperature was 7.5°C. The length of the internal current-electrode was 15 mm and that of the internal potential-electrode 5 mm. The membrane current is expressed in the total value, and not in values per unit area, because the partitions and the lateral ground electrodes in fig. 1 were not present in this experiment. Axon diameter,  $500 \mu$ .

amplifier gave the time course of the membrane current. Since the filter circuit exhibited ringing at the resonating frequency, the time resolution of this sensitive method was not as high as that of the original method. We adopted therefore a frequency of 16 kc/sec. instead of 8 kc/sec. in the original method.

An example of the records obtained by the modified method at low temperature is presented in figure 7. We were surprised to find no clear increase in the membrane conductance associated with the variable inward membrane current. The membrane conductance associated with the discrete surges were similar to those obtained by the original method without an electronic filter.

When similar conductance measurements by the filtering method were carried out at room temperature (20–22°C), we were able to demonstrate a small increase in the membrane conductance accompanied by the variable inward membrane current. The records in figure 8 were taken at a level of depolarization barely subthreshold for appearance of discrete surges. The conductance trace is seen to be considerably wider near the peak of the inward current. When the inward current was eliminated by a reduction of the sodium chloride in the surrounding artificial sea water or by dissolving ethyl-urethane in the sea water, the broadening of the filtered current



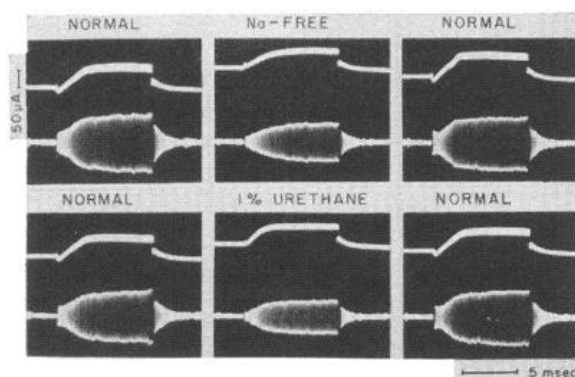

FIG. 8. Effect of sodium-free sea water (*upper row*) and of 1% urethane-sea water upon the membrane current and conductance of the squid axon under voltage-clamp. Temperature 21°C. For the upper 3 records the clamping pulse was 16 mv in amplitude and 8.2 msec. in duration; the 3 records in the lower row were taken from the same axon using clamping pulses slightly weaker than those used in the upper row. Axon diameter was 460  $\mu$ ; the dimensions of the electrodes were the same as in the experiment of fig. 7.

trace near the start of the clamping pulse of the same magnitude was almost completely suppressed. The effect of low sodium and of narcosis upon these properties of the axon was completely reversible and the observation could be repeated several times. The time courses of the membrane current and of the conductance observed under low sodium (the upper middle record in fig. 8) are very similar to those determined by Hodgkin and Huxley under similar conditions (fig. 13 in ref. 4).

#### DISCUSSION

The main features in the experimental results reported in the present series of papers (2, 3) and their direct consequence can be summarized as follows: 1) under the so-called voltage-clamp conditions, the intensity of the inward membrane current is not a continuous function of the magnitude of depolarization. A large surge of inward current starts suddenly when the clamping pulse reaches a certain threshold level (around 15 mv above the resting potential). At this level can be demonstrated an appreciable latency from the beginning of the clamping pulse to the appearance of the inward surge. 2) When the difference between the potential in the middle of the axon and that of the external fluid medium is maintained at a constant level of 15–35 mv above the resting potential, the membrane

current necessary to maintain this constant level undergoes an oscillation. 3) The oscillatory membrane current under voltage-clamp arises in the portion of the axon where the potential difference is kept constant and does arise near the end of the clamped portion. 4) In the axon which does not show the discreteness in its membrane current, the amplitude of the action potential of the axon varies more or less continuously with the intensity of the stimulating current pulse. 5) The appearance of a discrete inward membrane current is due to initiation of a full-sized response in a limited area of the surface membrane of the clamped axon. 6) The gradual increase in the membrane current under voltage-clamp with increasing depolarization in the range between 15 and 40 mv can be interpreted as a gradual increase in the area involved in excitation. This interpretation is supported by our exploration of the membrane potential of the axon under voltage-clamp with a microelectrode and also the measurements of the membrane conductance under voltage-clamp. 7) The time course of the membrane-emf can be determined directly from the simultaneous measurement of the membrane conductance and the membrane current. This time course can be interpreted as due to the distortion of the action potential by the existing strong membrane current followed by the secondary effect of the outward current upon the membrane.

In this connection, the difficulty of 'clamping' the membrane potential of the normal squid axon has become evident. The membrane conductance of a fresh axon undergoes a pronounced increase and the active membrane can tolerate a strong inward current without undergoing a transition from the active state to the resting. There are two other complicating factors in the voltage-clamp experiments on the squid axon. One of the factors is the nonuniformity of the axon membrane which was demonstrated by inserting a microelectrode into the axon under voltage-clamp. The other factor is the polarization of the internal electrodes.

These difficulties, unavoidable in clamping the squid axon membrane, are not present in the corresponding experiments on the node of Ranvier of the vertebrate nerve fiber. The

conductance of the nodal membrane undergoes only about a 10-fold increase. The non-uniformity of the membrane within one node is certainly far smaller than that in the large surface of the squid axon. All the electrodes are perfectly nonpolarizable. A difficulty inherent to the experiments on single node preparations is a slight ambiguity in the absolute value of the membrane current necessary to maintain the nodal potential at a constant level (9).

Because the possible sources of artefacts in voltage-clamp experiments in the toad nodal membrane are very different from those in the squid axon membrane, it is important to compare the behavior of these two different kinds of excitable membranes. Most of the properties of the squid axon membrane summarized above have been demonstrated in the nodal membrane.

Finally, the existence of a weak and variable inward membrane current in the squid axon membrane under voltage-clamp may deserve some comment. This variable membrane current can be demonstrated clearly in axons which have lost the ability to develop all-or-none responses. This variable component in the membrane current seems to always precede the appearance of a discrete inward current. An analysis of the relationship between the variable and discrete membrane

currents is now being carried out by one of us (C. S. S.). Our present speculation as to the nature of the variable component is to attribute it to appearance of activity at numerous microscopic or submicroscopic spots in the axon membrane. Somewhat similar speculations have already been made by Grundfest (10) and also by del Castillo and Suckling (11) to explain different kinds of experimental results. Then, the appearance of a discrete surge can be explained as indicating 'fusion' of these active spots as the result of restimulation by local currents (5).

## REFERENCES

1. HODGKIN, A. L., A. F. HUXLEY AND B. KATZ. *J. Physiol.* 116: 424, 1952.
2. TASAKI, I. AND C. S. SPYROPOULOS. *Am. J. Physiol.* 193: 309, 1958.
3. TASAKI, I. AND A. F. BAK. *Am. J. Physiol.* 193: 301, 1958.
4. HODGKIN, A. L. AND A. F. HUXLEY. *J. Physiol.* 116: 473, 1952.
5. TASAKI, I. AND S. HAGIWARA. *J. Gen. Physiol.* 40: 859, 1957.
6. FRANCK, U. F. *Progress in Biophysics* 6: 1752, 1955.
7. HODGKIN, A. L. AND A. F. HUXLEY. *J. Physiol.* 121: 403, 1953.
8. NERNST, W. *Pflügers Arch. ges. Physiol.* 122: 275, 1908.
9. TASAKI, I. AND A. F. BAK. *J. Neurophysiol.* In press.
10. GRUNDFEST, H. *Ann. Rev. Physiol.* 37: 337, 1957.
11. DEL CASTILLO, J. AND E. E. SUCKLING. *Fed. Proc.* 16: 29, 1957.